



NEW
SHORTCUTS
TO TV
SERVICING

LEONARD C. LANE

\$4.95
(in the U.S.)

VOLUME 1

new
shortcuts
to tv
servicing

LEONARD C. LANE

AUTHOR OF

How to Fix Transistor Radios and Printed Circuits

*gersback library inc.
new york 11, n. y.*



Copyright © 1958

*Radio-Television Training of America, Inc.,
and Leonard C. Lane*

Revised © 1961

*All rights reserved under Universal
International, and Pan-American
Copyright Conventions.*

Library of Congress Catalog Card No. 61-13970

chapter		page
1	Front-end trouble Tips on antennas. One antenna for two receivers. Testing transmission lines and the antenna. Ignition noise. Buzz. Ghosts. Boosters. Front-end troubles. Cascode tuners. Replacing local oscillator tubes. Microphonics. Picture smear. Jitter. Realignment of the front end. Front end test points. Noisy tuners. Trailing reversals. Receiver tube noise. Line voltage. Fringe area problems. Snow in the picture. Agc and the mixer tube. Oscillator inoperative. Tube adapter. Erratic reception. Resistance measurements.	1-7
2	Troubleshooting the if Tube troubles. Weak, gassy, and microphonic tubes. Heater-to-cathode leakage or short. Voltage checks. Realignment. Trailing whites. 60-cycle hum. Picture oscillation. Sound bars in the picture. Poor high-frequency response. Voltages in the if stages. Coupling in if stages. Audio tube as voltage divider. Wiggling in the picture. Checking video and replacing video if transformers. Faults due to other circuits.	1-35
3	Picture detector defects What the video detector does. Video detector components. Time saver. Vacuum tube detector. Checking video detector crystals. Precautions in handling crystals. Crystal detector troubles. Overloading. Diode performance. Checking intermittents. Vacuum-tube video detector. Horizontal picture hook. Picture smear. Picture, no sound. Hum bar in picture. Trailing whites. No picture, no sound, raster is ok. Unusual circuitry. Printed circuits. Gimmicks. Crystal detector circuitry.	1-59
4	Automatic gain control Types of agc. Separate agc diode. Threshold control. Dc bias supply. Alignment and agc. Keyed agc. Keyer tube failure. Excessive bias. Agc clamp. Clamp circuit troubles. Representative agc defects. Overloading. Excessive snow. Intermittents. Excessive contrast. Airplane flutter and picture flicker. No contrast. Agc voltage is zero, too high, or positive. Detector and agc. R-C values in agc circuits. 60 cycle sync buzz. Checking keyer voltages.	1-79
5	The video amplifier Video amplifier defects. Measuring video amplifier bias. Contrast-control troubles. Peaking coils. Picture smear. Overpeaking. Hum. Sound-trap troubles. Cross-modulation buzz. Oscillation suppressor. Local-distance switch. Capacitor voltage divider for sync. Unstable sync. Effect of video amplifier on keyed agc. Trailing reversal. Dim picture. Waveforms. White-reference pulse. Frequency burst signal. Bar signal. Stair step signal. Color burst signal.	1-107
6	Sync troubles Sync separator. Sync voltages. Sync-voltage measurements. Using the scope. Triode and pentagrid sync separators. Sync compression. Noise. Poor horizontal sync. Misleading symptoms. Tube troubles. Over-contrast. Low voltage. Bending or folding of picture. Jitter. Weak sync. Sync troubles and the video amplifier. Front-end trouble. Switching tubes. Sync buzz. Critical sync. Engraved effect. Unstable sync. Ghosts. Excessive heat. Split picture. Design changes. Lead dress. Picture stabilizer. Fringe-lock adjustment.	1-133
	Index	1-158

To Mildred

introduction

BETWEEN the covers of these volumes are compiled tricks and techniques that offer shortcuts to many repairs. They are based on a course offered by Radio-Television Training of America. Field service, bench and production test problems are grouped together by sections or stages where defects may interact. In this volume the rf, if, detector, agc and sync stages of the receiver are discussed. Many symptoms are repeated, where similar symptoms may be caused by defects in another stage.

Not concerned with theory or mathematics, our interest is solely in the defects of the basic circuits of TV receivers and their solutions.

Many production test techniques described are helpful in solving problems created by improper replacement-part installation or by previous faulty servicing.

The author assumes that a maximum number of prechecks have been performed before a chassis is removed from the cabinet. In servicing "trust only yourself" is your best motto. Never assume that someone else has performed a certain test. Furthermore never assume that a particular part cannot be defective because it hasn't failed on you before.

No attempt has been made to offer a crutch that will indicate that for such-and-so symptom replace C603. Instead a guiding hand proffers tests and techniques that will even help to solve future problems in circuits not yet in production. Each volume offers solutions of symptoms, not directions for individual defects that would otherwise require a complete library, a volume for each chassis model ever wired.

In the second volume, are discussed the defects encountered in CRT circuits, high-voltage, sweep and audio circuits.

LEONARD C. LANE

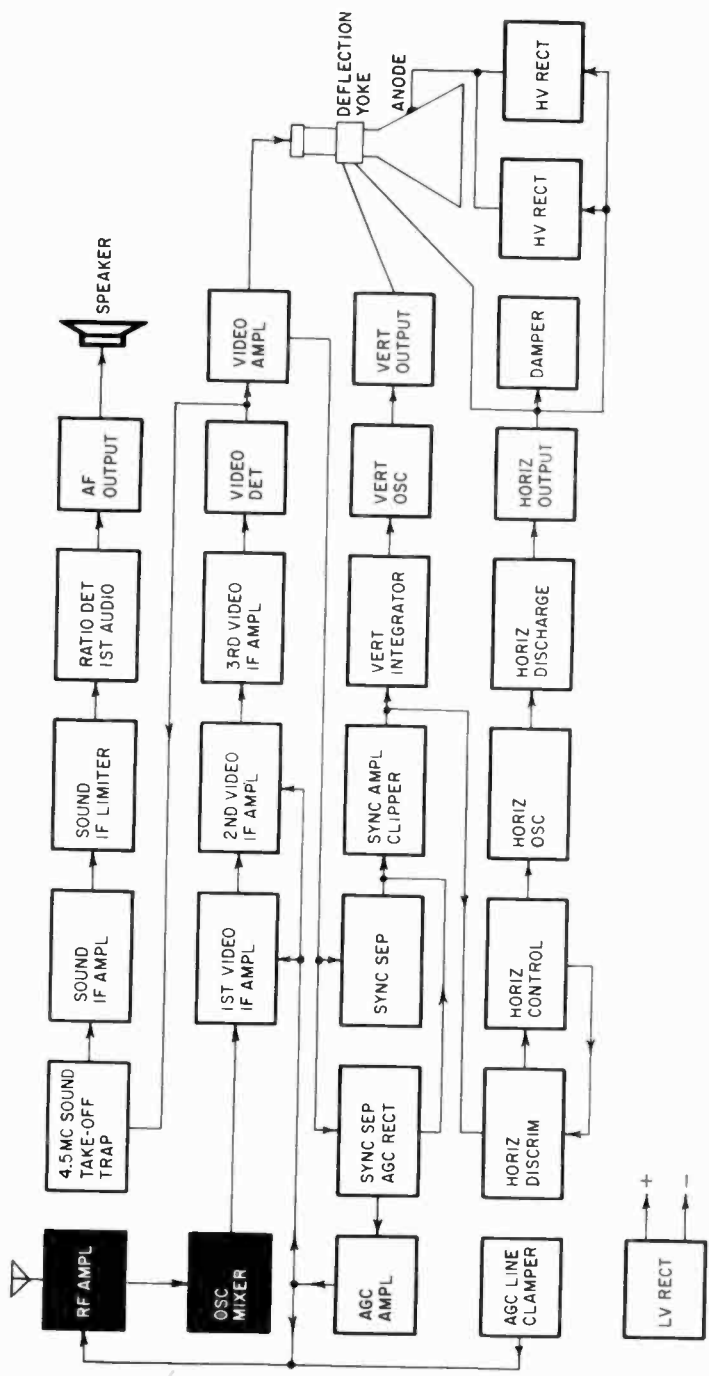

Fig. 101. Block diagram of a typical television receiver. This first chapter covers troubles in the rf amplifier and the mixer.



front-end trouble chapter 1

THE purpose of this book is to help you repair television receivers as quickly as possible. Whether you are a professional service technician or are interested in supplementing or adding to your present income, your greatest investment in servicing television receivers is not what you spend for tools, tubes or test instruments. Your greatest investment is **TIME**.

It's a matter of simple arithmetic. We do not know how long it takes you, on the average, to service a television receiver. Let us just assume that your average repair time is one hour. If you learn to make the same repair in one-half hour, you will have doubled your earning capacity.

TV theory

This is definitely not a book on *TV theory*. It will not teach you how vacuum tubes work, nor explain the theory of operation of sync separators, video amplifiers, sweep circuits, etc. It will show you how you can repair television receivers in a minimum amount of time by recognizing certain symptoms.

Our plan of attack

Fig. 101 is a block diagram of a television receiver. You have seen such diagrams before, but this one has been drawn particularly for this book. The subject matter for this chapter is shown in reverse (white lettering on a black background). By examining

the diagram carefully you will see that you are going to start with the antenna system and front end of the receiver and are going to work your way through the set, much in the manner in which the signal travels from the antenna to the picture tube and the speaker.

Time-saver

Never remove a TV set from its cabinet unless you really must do so. Taking a set out of its cabinet means removing knobs and screws and handling a heavy chassis — and there is always the possibility that you may damage some component. Many times a technician has pulled a set out of its cabinet only to find that all that was required was the adjustment of an ion trap, or tube replacement or a loose anode connector, etc.

In all cases it will be assumed that all possible tests of tubes,

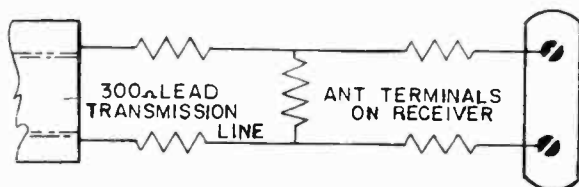

Fig. 102. All resistors must be the same value. Use 91- or 110-ohm $\frac{1}{2}$ -watt carbon resistors.

control adjustments, noise tests, arcing, etc. have been done. In many instances further checks will not be needed. Some of these basic tests are listed as reminders — others as a preliminary recheck before bench checking with instruments.

Some television receivers have many test points above the chassis. The number of test points will vary with different models and manufacturers. The test points are for your convenience. Look for them. Identify them. Use them.

Antennas

The importance of an antenna depends on quite a number of factors. A set with a high-gain cascode front end in a strong-signal area is less dependent on an antenna than one with a pentode tuner located in a fringe area.

Excessive signal can cause overloading of tubes. In TV reception, we try to get as much signal strength as possible. With today's set improvements we can get too strong a signal. This may cause picture instability (bounce) and smear. If the area has

more than one TV station, tune to a weaker station. If the smear or bounce disappears, then the fault is due to excessive signal. If smear and bounce remain for both strong and weak signals, then the trouble is in the receiver. The other causes of smear and bounce will be covered as we progress through the book.

If excessive signal strength is the trouble, insert the simple attenuator pad shown in Fig. 102. Use $\frac{1}{2}$ -watt carbon resistors

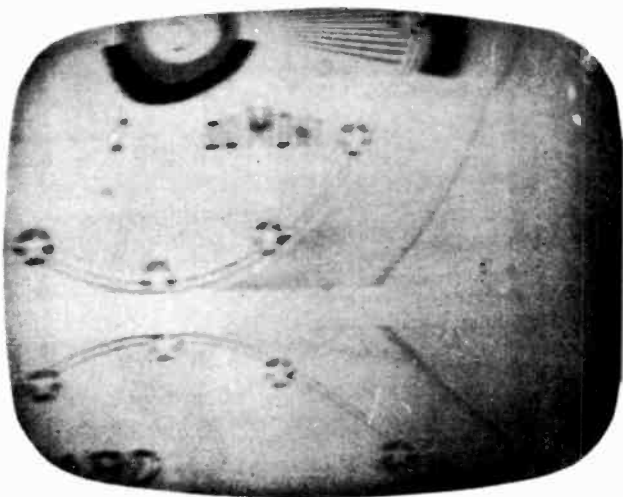

Fig. 103. Overloading may produce a negative picture.

and place the attenuator pad between the transmission line and the receiver—20% carbon resistors will do.

Overloading can also produce a negative picture as shown in Fig. 103. If the overload is very severe, a large negative bias will be developed between the picture-tube control grid and cathode, and may actually blank out the raster. A slight amount of overload can result in picture hook and excessive contrast.

Overloading can occur anywhere from the front end right up to the input of the picture tube. This means that all of the picture circuits *and* agc circuits are involved. This condition will be discussed again later.

Time-savers

Don't wait for trouble of the type just described. Build some of the attenuator pads shown in Fig. 102. They are easy to make, are inexpensive, and are handy in strong-signal areas.

When called in to service a TV set, take a quick look at the antenna *before* you go into the home. (Here we are referring to a private home, not an apartment house.) Is the antenna tilted, bent over, twisted around? Are any antenna director or reflector elements missing or damaged? Is the antenna facing in the same direction as other antennas on adjacent homes? Does the transmission line look secure?

Just a glance from street level will often give a clue to defective operation before looking at a receiver. In a seacoast area, it is possible for the antenna to become salt encrusted. Lowering

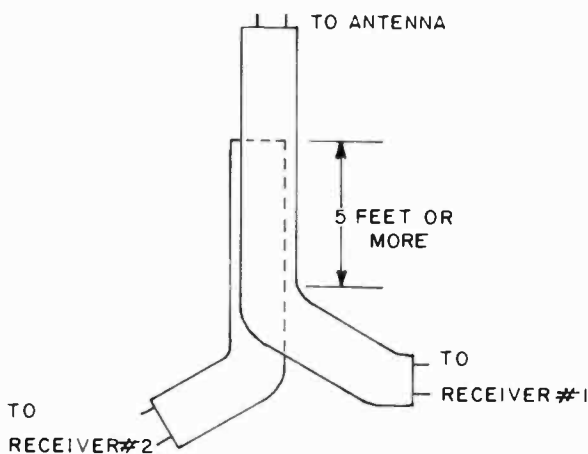

Fig. 104. In some signal areas two receivers can be operated from one antenna. Capacitance couples the rf to the taped-on transmission line.

the antenna to street level and then washing it down with fresh water will do much to restore the antenna to proper operation. And while the antenna is handy, check the connections of the transmission line at the antenna itself.

Tips on antennas

Consider the antenna as part of the receiver, even though it is outside the receiver itself. Antenna troubles can result in a weak or intermittent picture, poor sound in the picture, and rolling. To make a quick check on whether the antenna system is working, disconnect the transmission line at the receiver antenna input terminals and hook up an indoor antenna. If the trouble disappears, the antenna system is at fault.

If the owner of the receiver has made the installation himself,

it is entirely possible to find a large roll of excess transmission line coiled up behind the set. This is not only false economy, but can harm reception. The ideal transmission line is as short a line as possible.

You may find transmission line fastened to baseboards with screws, thumbtacks, nails, brads, hooks, etc. If used very sparingly, they do no harm, provided they do not short the wires of the transmission line or break any of the strands.

The symptoms of a weak signal are snow and weak sound (antenna or transmission-line trouble).

One antenna for two receivers

Sometimes space limitations, lack of time, inability to get on a roof, etc. will prevent the installation of more than one outdoor antenna. If this is the case, two receivers can be worked from the same antenna without any physical connection between them.

Simply run a length of transmission line parallel to the existing transmission line and fasten the two together with plastic tape. No soldering or other physical connection is needed. The two transmission lines should be placed flat against each other, in as close contact as possible, for a distance of at least 5 feet. The second receiver gets the signal because of the capacitance between the two transmission lines. This is illustrated in Fig. 104.

Testing transmission lines and the antenna

If signals are weak, the picture snowy, and there is vertical rolling, the trouble may be due to a defective transmission line and/or antenna. Here are some quick checks: (1) Substitute an indoor antenna. If the picture improves, then the fault definitely lies with the transmission line or antenna. (2) If the antenna is a folded-dipole type, run an ohmmeter test across the exposed transmission-line leads. First disconnect the transmission line from the receiver and then place the ohmmeter leads across the transmission line. A folded dipole should give a low resistance reading. An open dipole should give an infinite resistance reading. Some technicians install a 10K resistor across the antenna terminals (on the roof), making an ohmmeter check possible.

Transmission-line suggestions

Transmission lines should avoid all metal objects. Do not put the transmission line in any metal gutter. Do not run it close to or parallel to vertical pipes coming down the sides of buildings. Keep transmission lines away from all interference-producing

machinery. (This is important in buildings or apartment houses using elevators with operating machinery near or on the roof.) When installing a new transmission line, give it at least one twist per foot for its entire length. This helps minimize noise pickup.

When stripping transmission line, make sure that no strands are broken. Count strands after stripping both sides of the transmission line to make sure that this is so. When connecting the transmission line to the antenna terminals of the receiver, wrap the transmission line clockwise around the screw—that is, in the same direction the screw will travel when tightened, unless lugs are used.

Locating the trouble

A little earlier the importance of *not* removing the chassis until you are sure that it is necessary was stressed. Many TV troubles originate *outside* the TV set. Look at this list—weak picture, weak sound, snowy picture, no picture, picture bounce, picture smear, ghosts, intermittent picture, streaks in picture, diagonal lines in the picture, receiver completely dead. Do not get the idea that these troubles always come from outside the set. These troubles can also be produced by tube or circuit defects. But if you can make sure that the defective operation is not caused by some condition outside the set, you will have narrowed the search by that much.

Receiver lead-ins

In most receivers, the front end is located some distance away from the back of the set. Since the antenna terminal board is mounted on the back of the receiver, this means that some length of transmission line is used to connect the antenna terminals to the front end of the set. The transmission line used may be as short as 5 inches or as long as 1 foot. If, for any reason, you have to replace this transmission line, do not rest it too close to the chassis or near any radiating components. If the lead-in between antenna terminal posts and the front end is brought too close to the chassis, it may result in weak picture and sound.

Ignition noise

In some receivers, particularly older types and those located near heavy traffic areas, ignition noise caused by automobiles can be extremely annoying. Fig. 105 shows the circuit of a very simple ignition-noise suppressor. Put a pair of 50- μf fixed or variable capacitors in series with each leg of the transmission line. Wind

10 turns of No. 20 enameled wire on a form having a diameter of $\frac{1}{2}$ inch. Ground the center tap.

If the ignition-noise eliminator does not completely cure the problem, move the antenna lead-in as far from the noise-producing street as possible. It may be necessary to move the antenna to a new location.

Buzz

This condition can sometimes be caused by an improper impedance match between the front end of the receiver and the transmission line. Any one of the impedance-matching devices

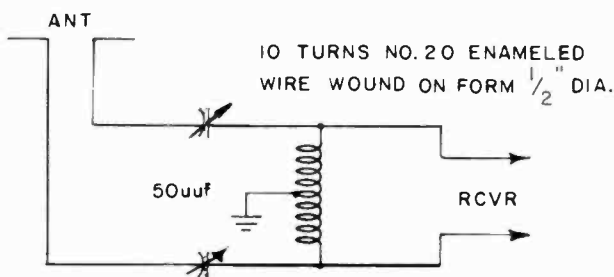

Fig. 105. Ignition-noise suppressor (high-pass filter). After winding the coil, scrape insulation from the center turn and solder a jumper to the chassis. The 50- μ f capacitors may be trimmers. Adjust for minimum picture streaking. The filter should be mounted as close to the tuner as possible.

described in the next section can supply a quick check for this type of trouble. If the adjustment of the impedance matcher reduces the buzz, then the trouble is definitely in the antenna system. Sometimes you can spot buzz due to mismatch because it will vary in intensity as you tune from one channel to the next. If, in intercarrier receivers, you hear a buzz on all channels and if the buzz is of equal intensity on all channels, then it is probably due to misalignment. If the buzz varies in intensity, or disappears as you rotate the channel-selector switch, then check the antenna system for impedance-mismatch possibilities.

Ghosts

This trouble can arise either in or out of the receiver. It is often due to a faulty impedance match between the transmission line and the receiver. Minimize it by using the device shown in Fig. 106. The capacitors can be 7- μ f to 35- μ f trimmers inserted in each leg of the transmission line close to the receiver.

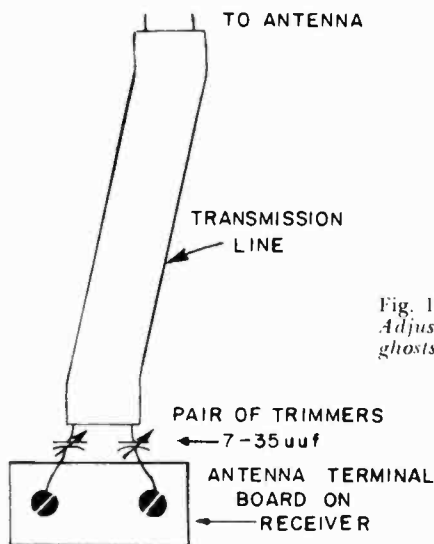

Fig. 106. Technique for eliminating ghosts. Adjust trimmers separately for minimum ghosts. Signal strength may also be improved.

Tune the channel selector to the station producing the strongest ghost condition. Adjust the fine-tuning control for the best picture, then rotate each trimmer in turn until the ghost is minimized or eliminated. Double-check on other channels to make sure that pictures from other stations have not been affected.

If tuning capacitors are not available, connect about 3 feet of transmission line from the antenna terminals of the receiver (Fig. 107) and allow it to hang freely behind the set. Starting at the antenna terminals, short successive portions of the transmission line until the best picture is received or until ghosts are minimized or eliminated. Use a razor blade or a sharp penknife as a shorting tool.

Another technique is to cut a 3-inch piece of aluminum foil (the type used for cooking is ideal for this purpose) and wrap it around the transmission line. Slide the metal back and forth, starting at the antenna terminals, until the best picture is obtained. Once the correct spot on the transmission line has been found, keep the aluminum strip in place with a small piece of tape.

Ghosts are an easily recognized symptom on the screen as shown in Fig. 108. However, if the ghost is sufficiently displaced from the picture, a wide bar may appear down the left side of the screen. A ghost is a secondary picture signal. In this case it consists of a signal that has taken a long path to the receiver while the primary (or original) signal has reached the receiver antenna di-

rectly. This means that the receiver is getting two signals—one straight from the station and a reflection of the same signal from some large object. Because the delayed signal takes a longer time to reach the antenna, it is shown as displaced to the right on the picture tube screen. The ghost signal is not only video, it contains all sync pulses as well. The vertical bar shown in Fig. 108 consists of the blanking and sync pulses of the ghost signal. The strength of the vertical black bar depends entirely on the strength of the ghost.

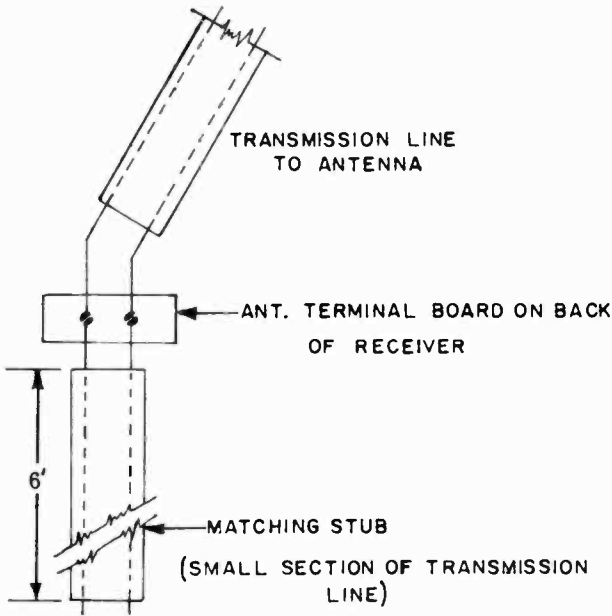

Fig. 107. Matching stub. Start at the antenna terminal board and keep shorting the matching stub along its length. At the point of best reception, remove insulation and twist wires together.

Sometimes ghosts appear as a reverse or negative picture. In this case, the vertical bar is white. The remedy here is to re-orient the antenna.

Ghosts can be either leading or lagging. That is, ghosts can precede the picture or they can follow it. When ghosts lead the picture, try placing metal shields over the rf amplifier and mixer tubes if they do not already have such shields. Make sure the shields are well grounded. Try connecting a rabbit-ear indoor antenna across or in parallel with the existing antenna. Adjust the indoor antenna until the ghosts disappear.

Ghosts can be caused by imbalance in the transmission line. To minimize or eliminate this, use the simple phasing unit shown in Fig. 109. Rotate the arm of the pot until the ghost disappears.

Time-saver

You will find many receivers whose reception can be improved by the very simple gadgets shown in Figs. 106, 107 and 109. They can be easily installed. You will always have at least one customer



Fig. 108. Picture with widely displaced ghost.

complaint that a particular station does not come in well. It takes but a moment to tune in the station and to try one of these suggestions to see if an improvement can be made.

Ghosts can also be caused by improper orientation of the antenna. Since this means a trip to the roof, *first* make sure that you cannot possibly eliminate the trouble with one of the various devices already described. Sometimes putting an indoor antenna (rabbit ears) in parallel with the outdoor antenna will help. Simply connect the indoor antenna to the antenna terminals without disconnecting the existing transmission line. Adjust the indoor antenna until the ghost is eliminated or minimized.

In an area of strong signals, try using the attenuator described earlier. It will cut down on signal strength, but it may also re-

duce the strength of the ghost to the point where it will no longer be noticeable.

Orientation of the antenna is an obvious solution to this problem, but it has many disadvantages for a service technician. It is time-consuming and it is often a two-man job. The other suggestions made here will often work as well, and require but a few minutes of the time of one man.

Boosters

Boosters are often used in fringe areas, especially with receivers that do not have cascode tuners. Boosters used in strong-

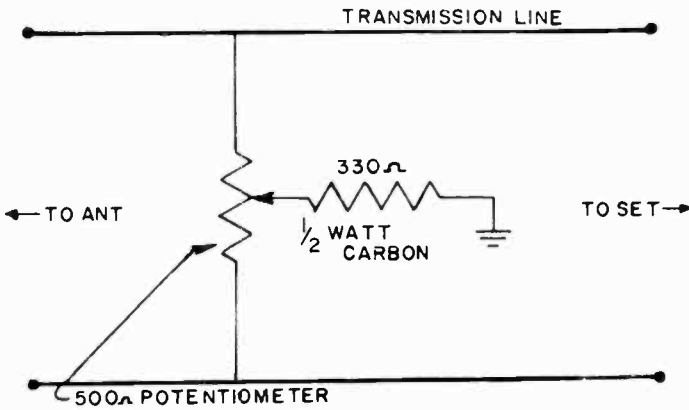

Fig. 109. Phasing unit can be used to balance some transmission lines.

signal areas will produce overloading, causing smear, distortion, and pulling. Detune the fine-tuning control slightly. If this improves the condition, then the trouble is definitely due to the booster. There are two solutions: (1) Substitute lower-gain tubes in the booster. (2) Insert an attenuator pad as shown in Fig. 102.

Front-end troubles

Sometimes tubes in the front end will make poor contact in their sockets. Turn the receiver on and tune to an active channel. Then gently wiggle the rf amplifier tube and the local oscillator tube, while noting the effect on the picture. If you can create an intermittent by moving the tubes gently over a small distance, then the trouble is a poor contact. If this is not the cause, tap the front-end tubes lightly with the rubber end of a pencil. Sometimes an intermittent is caused by a poorly soldered connection of one or more front-end components. Components are wired to

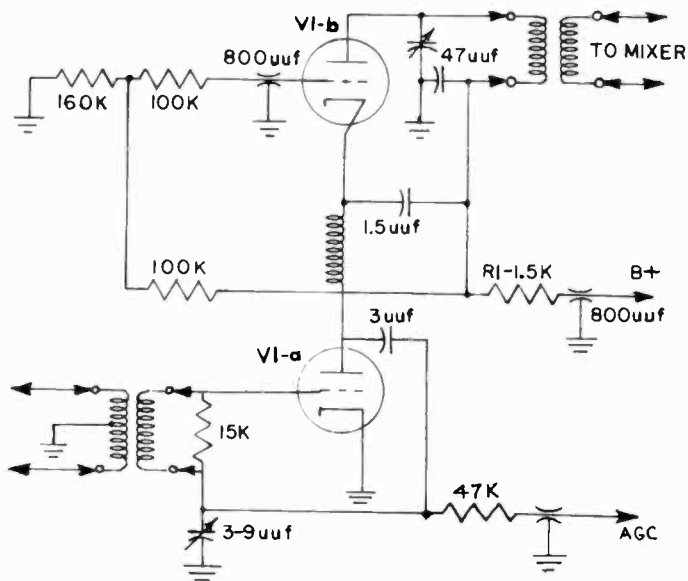

Fig. 110. Schematic of a typical cascode tuner.

socket pins, as they must be. Replacing tubes in the front end may cause the soldered connection to weaken.

Cascode tuners

These tuners are characterized by having two tubes in series. A representative circuit is shown in Fig. 110. Because the cathode of VI-b is at a moderately high B-plus potential, several difficulties can arise. There is much greater opportunity for a filament-to-cathode breakdown in VI-b than in VI-a. For example: A filament-cathode short in VI-b will kill the bias on VI-b, resulting in an increased plate-current flow. This burns out plate decoupling resistor R1. Replacing the resistor is of no use, since a replacement will burn out just as readily. If the resistor is burned out, replace the tube before putting in a new resistor.

A signal will get through VI-b (even though the decoupling resistor is burned out) due to capacitive coupling. The signal, however, will be weak and snowy.

Replacing local oscillator tubes

Sometimes replacing the local oscillator tube in a TV receiver will upset the tuning. If the oscillator tube has a shield, make

sure that the shield is on and well grounded before running any receiver checks. When replacing local oscillator tubes, always check the available channels to make sure that reception is at least as good as it was before the replacement was made. The fact that a local oscillator tube checks satisfactorily in a tube tester is not always an indication that it is perfect for replacement. It may be necessary to try a number of tubes until one is found that gives best receiver performance.

Microphonics

A microphonic tube can cause streaks in a picture or defective sound. To check a front-end tube to see if it is microphonic, short the antenna terminals. Gently tap (use the rubber end of a

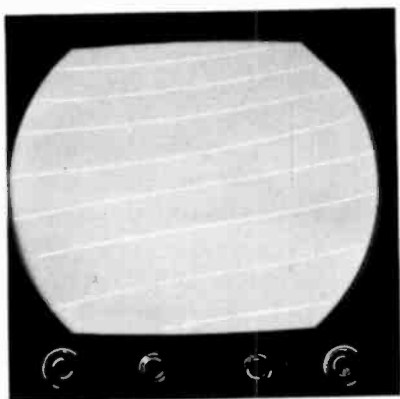

A fuzzy picture, but clear and sharp raster lines, indicates video, if and sometimes CRT trouble.

pencil) all the tubes of the front end. Turn the receiver gain control up and watch the screen. If tapping the tube produces flashes across the screen, replace the tube producing the symptom.

Loss of picture and sound

Since the picture and sound travel together through the front end, a loss of both may indicate trouble in the tuner. The raster will not be affected. Try replacing the rf amplifier first, and then the local oscillator.

Picture smear

Do not confuse picture smear with an out-of-focus picture. Check by tuning to an unused channel. Examine the raster. If the lines are clear, sharp and well defined right across the screen, then the focus is probably good. Picture smear is caused by poor low-frequency video response. Since the low-frequency portion of the signal deals with large objects, examine these in the pic-

ture. The large objects may be poorly defined (this sometimes creates a false impression that the trouble is due to improper focus). Examine large, dark areas on the screen. If the definition is poor and there seems to be a wide outline to the left of the dark area, then a smear condition exists.

One of the possible causes of smear is trouble in the front end. This could be caused by improper alignment or defective components. To determine if smear is caused by the front end itself or by an excessive signal, rotate the channel selector from one station to the other. If smear exists on all channels, then the trouble is in the front end. If it appears only when tuned to a strong station, the smear is caused by excessive signal strength.

Once you have determined the smear is not caused by excessive signal strength, tune in a picture on an active channel. Rotate the fine-tuning control. Note if you can change the amount of smear as you turn the fine-tuning control. If you can, then the trouble is probably in the rf amplifier.

If smear exists only on one channel, and it has been determined that the smear is not caused by signal overload, then realignment is indicated. Try making an oscillator adjustment to eliminate the smear.

When there is smear on all channels, and it is not affected by the adjustment of the fine-tuning control, the trouble is in one or more video if amplifier stages.

Jitter

Try controlling picture jitter with the contrast control. If it has no effect, and the jitter appears only on a single station (one supplying a strong signal), the trouble may be caused by excessive signal strength.

Realignment of the front end

Do not attempt to realign the rf portion of the front end unless you have the equipment and the know-how. You can, however, make oscillator adjustments without test equipment. When adjusting the oscillator be particularly careful to note the position of the slug before you start turning it. It should never be necessary to turn an oscillator slug very far—generally a quarter- or a half-turn is enough. Do not turn more than one oscillator slug at a time. Adjust an oscillator slug and then note its effect on picture and sound. If both picture and sound improve and if the fine-tuning control brings in best picture and sound when set to the center of its travel, then do not tamper further with the oscil-

lator-adjustment. Sometimes there is an interaction between oscillator sections of a front end. After making an oscillator-adjustment, tune in the other channels to make certain that these have not been affected.

On a particular channel, the fine-tuning control may go to one end of its range before picture and sound are satisfactory even though these may be good on all other channels. This is an indication that the oscillator for the particular channel is out of adjustment. With the help of the manufacturer's service notes, locate the oscillator adjustment for the channel giving the trouble. Rotate the fine-tuning control to the center of its range. As you adjust the oscillator, you vary the buzz coming out of the speaker. Adjust the slug until buzz is minimum and sound is perfect. In making this adjustment, use an insulated alignment tool. Do not use a metal-ended screwdriver. Some slugs are delicate. Do not force a slug beyond the end of its travel.

Front end test points

To make quick voltage checks, use the front-end voltage test points as indicated in the manufacturer's schematic. These test points are metal protrusions and have been known to short to the chassis. If other tubes receive normal B-plus voltage but front-end tubes indicate lower than normal voltage, make a physical check of front-end test points. Make sure that they are not shorting. A low-resistance short should blow the fuse if there is one. A high-resistance short will act as a load on the low-voltage supply, but will not blow a fuse.

Picture and sound are good, and then become defective

If picture and sound are good but become defective after a short period of operation, the trouble may be drift of the oscillator frequency in the front end. This condition is generally caused by a defective oscillator tube in the front end. If the tube has a shield, try removing it and then note if there is an improvement. Try replacing the local oscillator with several tubes to find one that gives minimum amount of drift.

If the drift persists, even with tube replacements, the trouble may be caused by defective components associated with the local oscillator in the front end. Since temperature-compensated components are used here, you must use an exact replacement. Furthermore, the component must be mounted in exactly the same spot; nor can you add extra lengths of wire. Be careful when placing components so as not to disturb lead wires. Wire placement in the front end is very critical.

Noisy tuners

Flashes across the screen as a tuner is switched from one channel to the next, or noise in the sound, indicates tarnished or dirty contacts. Use one of the commercially available cleaner lubricants to eliminate the trouble. Kits are available which will permit you to reach into hard-to-get-at-points in the front end.

Trailing reversals

This is smear. Use the same checks as indicated for conditions of smear.

Receiver tube noise

You have probably known about noisy tubes in connection with AM receivers, but this problem also arises with television sets. Noisy tubes in a TV set affect the picture and produce a condition that looks like snow. Quite often, we attribute a "snowy" picture to a weak signal (and quite often that is true) but a similar condition is produced by defective tubes.

Use the receiver itself as a tube tester. Connect a wire across the antenna input terminals of the receiver. Turn the picture contrast control to its maximum position and set the channel selector to an unused channel.

Set your vtvm to read dc volts — preferably about 1 volt maximum, full scale. Connect the test leads of the instrument across the picture detector diode load resistor. If the meter reads 0.6 volt or more, then one or more tubes are noisy. (If the pointer of the vtvm tends to move toward the left, instead of upward to the right, simply transpose your test lead polarity.)

If this test does indicate noise, make the following substitutions. Do not disconnect the meter. Make just one substitution at a time and watch the meter as you do so. Make the substitutions in the following order:

1. Video detector tube. If a semiconductor is used, make a substitution for it also.
2. The local oscillator tube in the tuner. Substituting this tube, however, while improving the signal-to-noise ratio, can also affect the tuning of the receiver. Try a number of oscillator tubes.
3. The if amplifier tubes. Start with the if tube closest to the front end and work your way toward the detector.
4. Examine the high-voltage supply to make sure that there is no corona or arcing. Radiation can be picked up by the picture detector, rectified and the resulting noise voltage amplified by

the video amplifier and sent along to the picture tube where it will appear as snow.

Line voltage

Quite often causes external to the receiver will produce symptoms that might make you believe the receiver is at fault. These symptoms are insufficient brightness and a small picture (picture is small both vertically and horizontally and seems blurred or out of focus). The trouble may be low line voltage. The symptoms we have just described can appear if the line voltage drops as little as 15 volts. Also check the line voltage if the complaint is that the receiver works well during the daytime, but poorly in

This variable line voltage transformer is metered. The receiver plugs into the transformer and the transformer is plugged into the power outlet.

(Chicago Standard Transformer Corp.)



the evening. A heavier night-time load on the power line can cause such conditions. If the picture shrinks when an appliance in the house is turned on, then the ac line is being overloaded.

Remedy due to an overloaded line: the only remedy is paralleling the existing line with another cable or install a new line capable of carrying a heavier current. This is a job for an electrician. If the line voltage is low at all times and does not change when appliances are turned on, then the only solution is to install a step-up transformer.

Fringe area problems

There are a number of techniques you can follow to get best results from receivers that work in fringe areas. No strict rules can be given since you must become familiar with the difficulties of a particular location.

Tubes: Not all tubes are alike, not even those of one type by a single manufacturer. This does not mean that the manufacturer is at fault, but it does indicate that you should expect certain tolerances in tubes just as in any other mass-manufactured item.

Considerable benefit can be obtained by using a "hot" tube as the rf amplifier. Check the tubes you have in stock. Those having the highest gain should be placed apart and used in receivers that seem to need just an extra bit of gain. A way to check rf amplifier

tubes is to connect your vtm across the video detector diode load resistor. Set the vtm to about 10 volts dc, full-scale deflection. Tune in a test pattern (a steady signal is needed). Adjust the fine-tuning and contrast controls—then do not touch them again. Now substitute rf amplifier tubes, one at a time. (You have to use a fixed bias across the agc bus since the agc will try to compensate for differences in tubes). Tubes having the highest gain should be identified by some mark.

You can also use this technique for video if amplifier tubes. Use these tubes closest to the front end to get the best results.

Not all tubes preceding the video detector are tied into the agc bus. If the rf amplifier or one of the video if tubes does not receive agc voltage, use a high-gain tube in that location. The absence of agc will enable the tube to work at maximum amplification.

Transmission Line: Twin-lead or two-wire lead-in carries the signal from the antenna to the receiver. As such, there is a loss in the line, the amount of loss depending upon the characteristics of the line and the accuracy of the impedance match between the antenna and the line, and between the line and the receiver. Use the impedance-matching devices described earlier in this chapter to determine if you can improve the signal strength. A quick check is to run your hand along the transmission line. If this action changes the picture, then the impedances of the line and the receiver are not matched.

Antennas: Height is obviously important, but isn't always available. If you have a large area available, try using a rhombic antenna. This is a rather drastic solution since this type of antenna may extend some 225 feet or more in length. Small versions have been installed in attics. If all channels are received with the exception of one desired channel, you can install a stacked Yagi designed for that particular channel.

If Realignment: Manufacturers sometimes align their sets, to operate in fringe areas, differently. This special procedure may be made available by the company on request.

Sync Action: In weak-signal areas we are concerned not only with signal strength, but with the amplitude of the sync pulses as well. Both the picture tube and the sync separator are usually fed from the output of the video amplifier. The signal strength to the picture tube can be determined by the setting of the contrast control. The input signal level to the sync clipper is sometimes set up by a potentiometer or a switch, allowing bias on

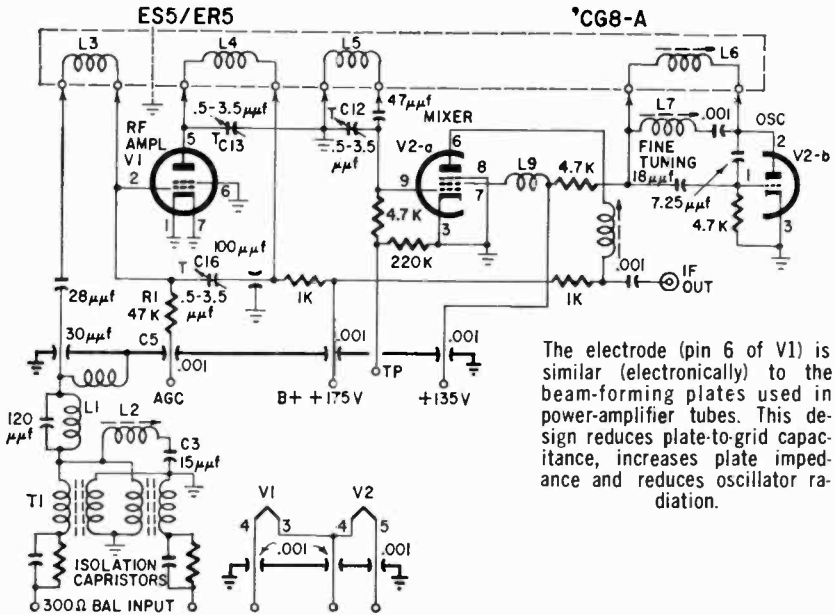

The single rod antenna used to replace the long-familiar "rabbit-ears" needs a balun coil circuit to provide a balanced input to the TV tuner.

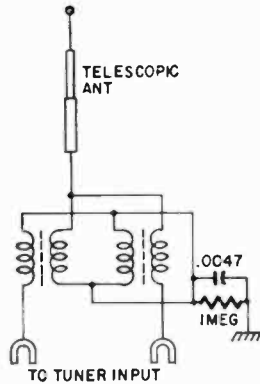

Snow is really tube-generated noise that can be seen. Such a condition is often produced by a defect in the rf amplifier or antenna.

Sound bars in the picture can be due to a misadjusted sound trap, microphonic oscillator tube or a defective stacked B-plus decoupling filter. With the volume turned down, sound bars caused by the last two will disappear. A microphonic tube will be indicated by tapping the tubes and chassis.

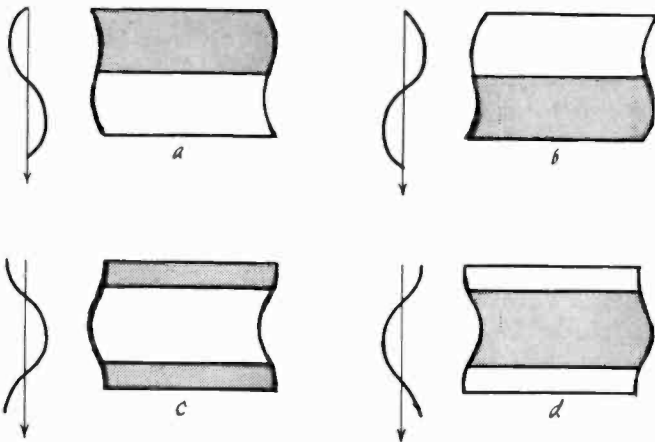

Heater-to-cathode leakage in the tuner or if circuits will usually show in the edges of the raster. The direction of ripple depends upon the phase inversion between sync takeoff and the horizontal oscillator control.

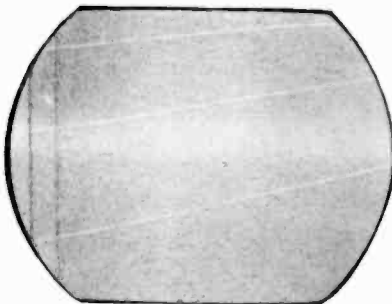

Barkhausen oscillation is generally due to a combination of weak signal to the tuner and excessive horizontal sweep pick-up on the lead-in. Readjusting the horizontal drive may reduce or eliminate this.

the sync clipper to be changed. The sync adjustment has a large variety of names: sync lock control, noise control, fringe lock or fringe lock control, noise-cancellation control, etc. Since, in weak-signal areas the signal-to-noise ratio is poor, this control must be adjusted so that noise pulses do not upset sync.

Agc Adjustment: Adjust the agc control so that the rf amplifier and video if amplifier tubes get the least amount of agc bias. This permits these tubes to work at maximum gain. This adjustment, however, sometimes produces noisy sound since the re-

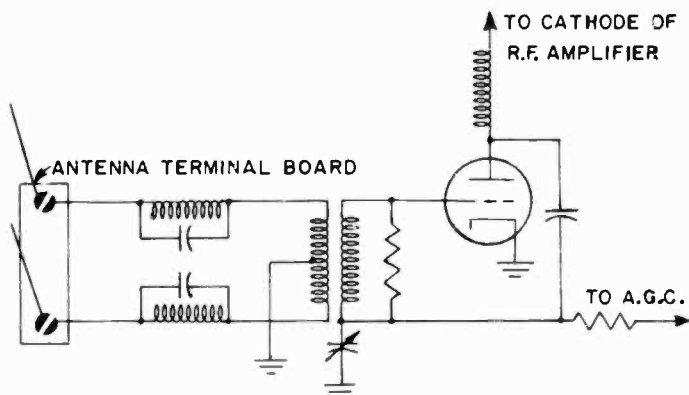

Fig. 111. One type of balanced input to cascode rf amplifier.

ceiver is operating at its maximum sensitivity. To minimize or eliminate noise, retune the sound takeoff transformer and the sound if transformer. Tune the primary of the sound detector transformer (whether ratio detector or older style discriminator) for maximum volume.

Snow in the picture

There is a difference between a weak, washed-out picture and one that has snow in it. Snow is a form of static and, when it appears in conjunction with a weak picture, we say that the picture is snowy. As a general rule, a weak picture (without snow) is associated with troubles following the front end.

Snow is generally due to front-end trouble or to some condition outside the receiver. The signal-to-noise ratio isn't good. A defective antenna (twisted around, broken elements, poor connections, corrosion) can cause this condition. If an indoor antenna improves the picture, the trouble is external to the receiver. The transmission line is also open to suspicion.

If the outside antenna and transmission line are free of trouble

(and a substitute indoor antenna does not improve matters), then the problem can exist between the antenna terminals and the output of the rf amplifier tube. As a receiver check, substitute a new rf amplifier tube.

Fig. 111 shows a typical balanced input to an rf amplifier in the front end. Examine the antenna terminal board. This is a small rectangular piece of insulating material riveted to the rear apron of the receiver. The terminals to which the transmission line are attached are close to the chassis. It is possible that some stray strands of wire of the transmission line are touching the chassis, or the other terminal.

The input to the antenna transformer may be open on one side. Connect an ohmmeter across the antenna terminals (with the transmission line disconnected). Check from either terminal to the chassis. The resistance reading should be that of any series resistance between the terminal board plus the resistance of one-half the antenna transformer winding. Repeat by checking in the same way from the other antenna terminal to the chassis. If one side shows a resistance reading, but the other side is open, then trace through on the open leg up to and including the primary of the antenna transformer to locate the open.

Removing tubes

Removing and replacing tubes in the front end isn't always an easy job. Tubes used in the front end are miniatures, and pins can be damaged. When inserting such tubes, you may often find it impossible to see the socket. A flashlight and a dental mirror are helpful when making replacements. In some sets you may even have to pull the chassis.

Be careful not to bend tube shields sideways when removing them. This can bend tube pins. Also note that some shields grip the tubes. Thus, removing a shield means pulling the tube along with it. When putting shields back on, make certain that they are in firm contact with their ground connection near the base of the tube. Just dropping the tube shield on (when this can be done) isn't satisfactory.

Removing the chassis

A set that is turned off or with the line cord disconnected isn't always safe. The picture-tube inner and outer coatings are a capacitor and capable of holding a charge for a long period of time. To be safe, short the high-voltage connector to the chassis. Many receivers are of the transformerless type; the chassis is connected

directly to the power line. Whether the chassis is "hot" or not depends on the positioning of the plug in the outlet. If you have the set out of the cabinet for servicing, connect a light bulb between the chassis and any cold-water pipe (or other good ground), as shown in Fig. 112. The bulb lights when the chassis is hot and the line plug should be reversed. After you have reversed the plug, make another check just to be sure. You can also use a meter (set to read at least 150 volts ac) or a neon-lamp tester for making this test.

For safety, use an isolation transformer. Make a permanent mount for it several feet (preferably as far as possible from the

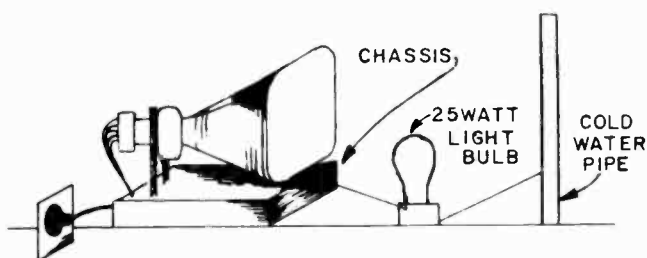

Fig. 112. Using test lamp to check a transformerless receiver for a "hot" chassis. Reverse the line plug and check again. Use the connection which gives no light on the test lamp.

test bench. Such transformers, especially the open or unshielded type, have a strong magnetic field that can interfere with the proper operation or servicing of the receiver.

Agc and the mixer tube

The agc bus feeds the rf amplifier and one or more video if tubes. We usually do not think of agc in connection with the mixer in front end and yet, indirectly, the mixer can be affected by agc. In some receivers, the bias of the mixer is obtained from the rf amplifier tube. However, the rf amplifier tube depends upon agc for its operation, and thus the agc voltage will also determine the amount of bias on the mixer tube. A mixer tube that is not working properly may be doing so, not because of any fault in the mixer, but because the agc voltage to the rf amplifier is incorrect.

Flashes in picture

For flashes that appear across the screen or a channel selector that must be wiggled back and forth to keep a picture locked in,

the tuner may need cleaning and lubrication. There are a number of manufacturers who make cleaner lubricants expressly for this purpose. Some of these come in pressurized spray cans.

When cleaning a rotary switch by applying the cleaner on a cotton swab, be careful not to damage the switch. The rotor and stator of such switches require very careful handling not to be bent out of shape. Applicators are available which permit you to put a drop of lubricant in a hard-to-reach spot in the tuner.

When cleaning turret type tuners, clean each strip with cotton soaked in cleaner lubricant. Examine each contact point to make sure that it is not excessively worn. If it is, it may be necessary to replace the strip. Rotate the turret and clean each strip in turn. Tarnished contacts can be polished with a silver polishing cloth. Then lubricate.

An isolation transformer removes one type of shock hazard from servicing a transformerless TV chassis.
(Chicago Standard Transformer Corp.)

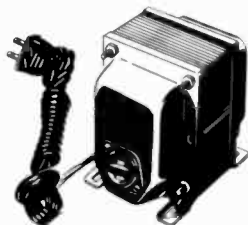

When cleaning continuous tuners, apply cleaner lubricant to the wiping contact. Wipe it clean while rotating the tuning control from the front of the set.

Oscillator inoperative

If the oscillator in the front end stops working, there will be a complete loss of picture and sound. Most often this is due to a defective oscillator tube, as indicated earlier. To determine if the oscillator is functioning, connect a vtvm set to read not less than -10 volts dc full scale with the common lead going to the chassis and the probe to the control grid of the oscillator tube. The voltage should be between -3 and -10 . Rotate the channel selector. If the oscillator grid voltage is correct for all channels except one, then the strip (turret type tuner) for that channel may be defective. Try cleaning the strip contact points. Although the impedance of the oscillator grid to ground isn't very high, it is advisable to use a vtvm in making this check. Sometimes even a small amount of loading, such as that imposed by a vom, may prevent the oscillator from working.

Look for the oscillator voltage test point. It is much easier

and more accessible than the pin of the tube. If no test point is available, remove the tube shield (if it has one) and lift the tube slightly out of its socket. With the tube in this position, but still functioning, gently touch the oscillator pin with the probe of the vtvm. If you do not get a negative reading, make a voltage check on the plate (be sure to reset the vtvm to read the higher positive voltage). (Vtvm's have a front-panel switch for changing input polarity).

If the oscillator plate voltage is normal (or slightly higher than normal), remove the tube and examine the pins. Sometimes

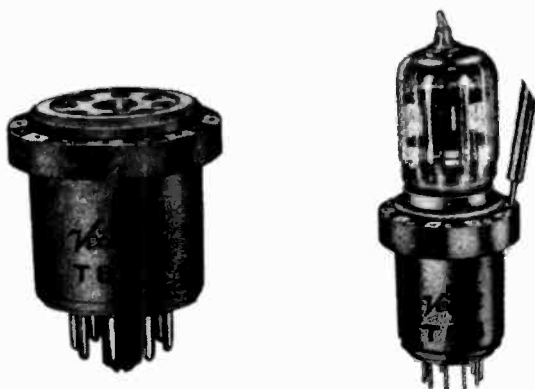

Fig. 113. *Test adapters allow many voltage and resistance tests without removing chassis.*

spread pins or spread socket contacts will keep the tube from working.

If oscillator bias voltage is missing, try not to operate the tube for too long a period of time. In the absence of bias, the tube current rises considerably, resulting in possible damage to the tube.

Tube adapter

If the receiver has no front-end test points and if lifting the tube is troublesome, use a tube adapter. The adapter, inserted between the tube and the socket, will permit you to make a check of the oscillator and plate voltages. Typical adapters are shown in Fig. 113.

Erratic reception

Quite often the front end or tuner is a completely separate assembly. When it is mounted on the main chassis, the common

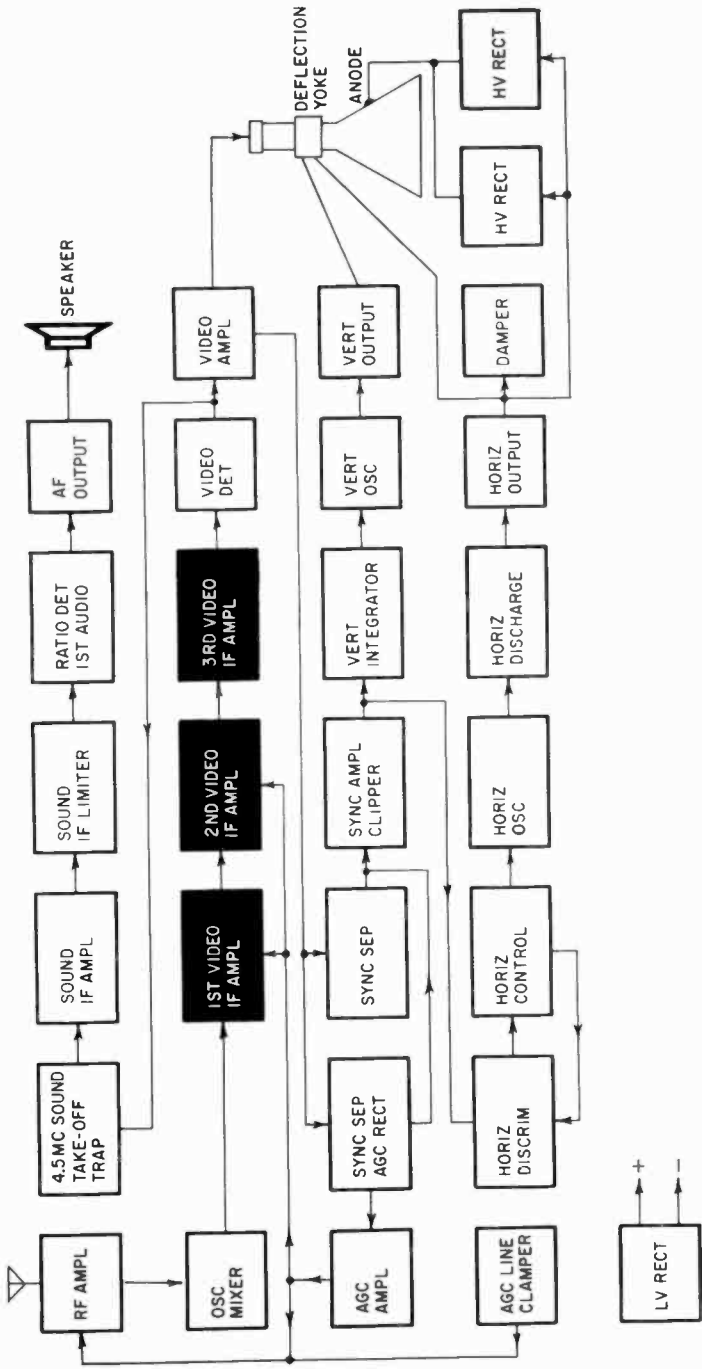

Fig. 201. The signal travels from the front end to the if section (shown here in reverse). The if produces its share of troubles, described in this chapter.



troubleshooting the if

chapter 2

AFTER the signal passes through the front end (or tuner), it is strengthened by a wide-band unit known as the intermediate-frequency (if) amplifier. We are, as you can see, following the progress of the signal and learning about the various things that can happen to it on its way to the picture tube and speaker. Fig. 201 shows the portion of the television receiver that will be covered in this chapter.

Quite often, defects in widely separated and independent circuits in a television receiver can produce identical symptoms. For example, a microphonic tube in the tuner and a microphonic tube in the if system can both result in bars across the screen. For that reason, you will find many symptoms described over and over again as we progress through this book. It would be ideal if each trouble in each stage produced a very definite and distinctive symptom, but unfortunately it just isn't so. A headache can be brought about by eyestrain or a tight pair of shoes. In other words, the same result is produced by different causes.

Troubleshooting the if

The intermediate frequency section of a television receiver (shown in block diagram in Fig. 201) has several important characteristics: (1) It supplies a certain amount of gain, building the signal up to the point where it can operate the picture detector and (2) the bandwidth of the if stage must be great enough

to allow both picture and sound information to get through. Because of the need for gain, pentodes are most often used. In general, you will find the if section of a TV receiver has three stages plus one or more accompanying traps.

The troubles that arise in the if section are quite often due to tubes. Incidentally, a tube in the if section can be completely dead and yet enough signal can leak past, by stray capacitance, so that a picture will appear on the screen. The picture, however,

Various traps and sound if transformers are shielded in aluminum cans. The video if transformers are not shielded since feedback isn't usually found in stagger-tuned if's.

(Chicago Standard Transformer Corp.)

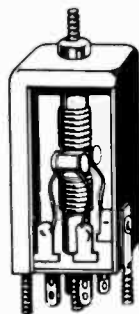

will give evidence of its weakness. It will look washed out, and it will have a tendency to drop out of sync.

Tube troubles

You will generally find the tube lineup pasted somewhere near the inside top portion of the cabinet of the receiver. If not available, then check the schematic of the receiver. Locate the if tubes. With the set on, see if all filaments light (we assume that these tubes are connected in parallel). Here are the various tube troubles that can occur: (1) one or more tubes completely dead; (2) weak tubes; (3) gassy tubes; (4) microphonic tubes; (5) heater-to-cathode leakage or short; (6) tubes not properly positioned in socket; (7) wrong tube in socket; (8) tampering by customer; (9) tube pins bent and not making proper contact; (10) tube shields (if any) missing.

In many cases, the troubles listed can result in identical symptoms. For example, a tube that is extremely weak might give the same results as a tube that is completely dead. An intermittent tube might produce the same effects as a tube making poor contact with its socket. In examining the if section, make sure that all tubes are seated firmly. Examine the tubes to make certain that each tube belongs where it is. Rotate the channel selector to a different station. If the trouble persists on two or more channels, then the fault lies within the receiver.

Check all the if amplifier tubes. Often all the tubes are of the same type, so you will need to make only one setting on a tube checker. This test can be made rapidly. If you do not have a tube tester, use a tube-substitution check. Do not replace more than one tube at a time. In making a tube-substitution check, first adjust the controls on the receiver for the best picture. Substitute one tube at a time, but do not touch receiver controls. If, after replacing a tube, you notice a considerable improvement, the tube you have just replaced is a defective one. A tube-check may show one or more of the if amplifier tubes as weak or other-



Series-filament continuity testing is simplified by the inexpensive ac-powered units. Neon tubes may be wired to indicate either open or good tube filaments. Test leads can be used for fuses and other component testing.

wise defective. Replace these tubes. Quite often a poor picture is not the result of just one weak tube, but is caused by several tubes having lowered gain.

Trouble will often be due to an open filament. Make a continuity check across the filament pins of the tube with the tube pulled out of the receiver. Filament resistance should be practically zero. Be careful not to bend the pins of miniature tubes in making this check. Do not use test prods to make this test, but use prods terminating in alligator clips. If resistance checks show an open, then replace the tube. Generally, a dead tube will result in a complete loss of picture but, in strong-signal areas, enough of the picture signal can leak through to supply a very weak picture when the contrast control is turned to maximum. If the set is of the intercarrier type (as is most often the case), then both picture and sound may be missing.

If the receiver you are checking has series-string filaments, an open filament can cause a large portion or all of the tubes to fail to light—depending entirely upon the way in which the series strings are wired. It is much easier to find a tube with an open filament in a receiver using parallel wiring. The tube that doesn't light is a defective one. In a series-string, however, one

open tube deprives others of filament voltage. Use either an ohmmeter (as described earlier) or an ac voltmeter. Set the instrument to read at least 150 volts ac full scale. A tube having a good filament will read zero voltage (even though the tube is good, there is no voltage across the filament). The defective tube will be the one that has a high ac voltage across it. This voltage will generally be that of the line — 117 volts, ac (rms). (We will cover this topic again — and much more fully — when we reach Chapter 11. This filament line is also considered part of the power supply.)

Weak tubes

Picture and sound will be weak and picture may have a tendency to slip out of sync. Use the tube-substitution test or check tubes in tube tester.

Gassy tubes

Examine the tube with the set turned on. If the tube has a blue glow in it or shows white around the base, then it should be replaced. Remove the tube from receiver. A gassy tube can produce a variety of symptoms. Generally, however, it will result in a picture whose contrast changes fairly often. The receiver may be operating properly and then the picture will become a negative one.

Microphonic tubes

A microphonic tube is one whose elements change their position. The vibration of these elements is so small that it cannot possibly be observed by looking at the tube. If you suspect a microphonic tube, turn the receiver on and select a good clear picture. Tap the tube gently with the rubber end of a lead pencil. If bars appear on the picture screen, then the tube is microphonic. Replace the tube and repeat the test to make sure that the tube you have substituted does not also have the same trouble. If bars are produced on the screen every time someone walks across the room or taps the receiver, then the trouble can very easily be a microphonic tube.

Heater-to-cathode leakage or short

Examine the picture. Picture bending across the top may be caused by one of the if tubes with a cathode-to-heater short. Check by tube substitution. Instead of a short, there may only be leakage between heater and cathode. If such is the case, the picture signal may be modulated by a hum voltage. Examine the

picture on the screen. It may seem to have wide horizontal light and dark areas. These light and dark areas will have a tendency to roll vertically. Check the tubes in the if section by substitution.

Tube not properly positioned in socket

Sometimes one of the if tubes may loosen in the socket, resulting in a variety of troubles depending upon the position of the tube. If the tube is all the way out of its socket, the effect will

Without a picture it is hard to tell if hum is injected before or after the sync takeoff point as the oscillators are free-running when sync pulses are not present.



be the same as that of a dead tube. Push down gently on each of the if amplifier tubes to make certain that they are seated firmly.

Wrong tube in socket

Some owners of receivers will try to make a tube replacement and in so doing will put the wrong tube in one of the sockets. Do not expect the owner to admit that he has tampered with the set. Examine the tube numbers and make sure each tube is in its proper position.

Tube pins bent

Quite often the only difficulty with an if section will be a tube pin that has been bent. Use a tube-pin straightener and then replace the tube. Do not try to flex pins on miniature tubes. Never force a tube into its socket. It should slide in smoothly and firmly. Do not twist a tube when inserting it. Do not leave miniature tubes loose on the bench, since accidentally placing any tool on the tube pins can bend them. When inserting miniature tubes in a chassis that is still in its cabinet, use a flashlight to make certain that the pins of the tube match the holes in the socket before attempting to push the tube into place.

Tube shield missing

Tube shields are used to prevent unwanted pickup by that particular tube. Tube shields are mostly used in the front end.

In some sets they are in the if section too. The shield should make good contact with its ground clip at the base of the tube.

Your first step in checking the if amplifier section should be on tubes. Do not attempt any B-plus voltage checks, trap adjustments, resistor or capacitor checks, unless you have first made certain that the tubes in the if section are not dead, weak or otherwise defective. If the tubes are in good condition, then an examination of the picture on the screen will often give you a clue to the source of the trouble. If the if tubes are in good condition, run a check on B-plus voltages. (It is entirely possible for a receiver to exhibit various troubles because of a misalignment but, postpone any sort of realignment until you have made the following checks.)

Voltage checks

First check the B-plus voltage on the plate of each of the video if amplifier tubes. If the voltage on any particular tube is missing, check for an open-circuited if transformer or series resistor. If plate voltages are normal, then run a check on the screen voltages (in all these voltage checks, it is highly advisable to use a vacuum-tube voltmeter).

If the B-plus voltage on the plate of one if amplifier tube is normal, but below normal on another if amplifier tube plate, then the trouble is definitely not in the low-voltage supply but is due to some defect in the video if amplifier. If, however, B-plus voltage on all of the plates of all of the if tubes is low, then check the B-plus all the way back to the low-voltage rectifier. Low B-plus on one or more of the video if amplifier tubes will result in a weak picture or critical sync. If a condition of low B-plus exists at the plate or screen of any one of the video amplifier tubes, check all components in series with plate or screen and also check for leakage of shunting units such as capacitors.

A representative if stage is shown in Fig. 202. Note the resistor (8,200 ohms) across the secondary of the input if transformer. Its purpose is to lower the Q of the coil, thereby increasing its bandpass. Doing this lowers the gain of the circuit. If this resistor should open, the gain will rise, increasing the signal input to the second if tube and to the following stages. Consequently, the agc bias will rise, bringing down the gain of all tubes connected to the agc bus. There will be two effects: One is the increased bias on the agc controlled tubes. More serious will be the narrowing of the bandpass of the if signal, resulting in a loss of fine

picture detail. To check the resistor with an ohmmeter, first unsolder one end of it since it is shunted by the very low resistance of the transformer winding.

Should the primary of the second if transformer open, the result would be zero plate voltage. With the loss of plate voltage, the tube current would decrease. This would reduce the bias

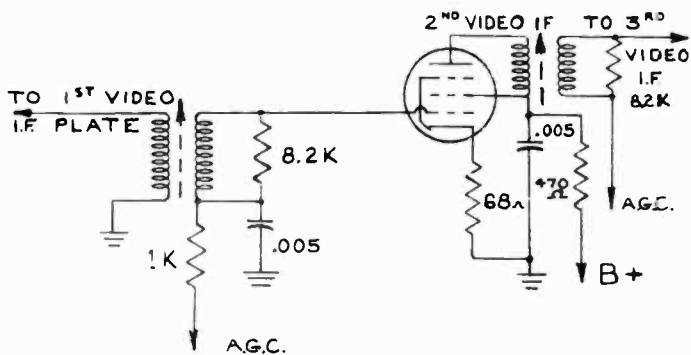

Fig. 202. Typical second video if stage.

voltage developed across the 68-ohm cathode resistor and, as a consequence, the cathode current would tend to rise again. Since the screen would be the only positive electrode, the rising current would flow toward it, quite possibly burning out the screen. In practically all if stages, plate and screen voltages are either identical or almost so.

If there is zero voltage on the plate and screen, check the decoupling resistor, shown as 470 ohms in Fig. 202. Check the resistor with an ohmmeter (with the set turned off) or else measure the voltage drop across the resistor. The voltage across this resistor should be a few volts dc. If the voltage across this resistor is zero but the plate and screen have their full voltages, the 470-ohm decoupling resistor is not defective. Check the 68-ohm cathode resistor. If this resistor is open, no current will flow through the tube and there will be no voltage drop across the 470-ohm resistor. A check can be made on the cathode resistor either with an ohmmeter or by measuring the bias voltage developed across it.

Do not assume that a cathode resistor must always be returned to ground. In the circuit shown in Fig. 203, for example, the cathode of the second if tube (V2) is at 100 volts plus and is connected (through the cathode resistor) to the screen grid of the

preceding tube! The only way to measure the bias voltage of V2 is between the control grid and cathode of that tube. If you were to measure it between cathode and ground, your meter would read 100 volts.

Now let us go back for a moment to Fig. 202. A defect in any one of the components in that circuit will affect that circuit only. If the cathode resistor, for instance, should become defective, other circuits would not be disturbed.

However, consider the circuit shown in Fig. 203. If V1 becomes

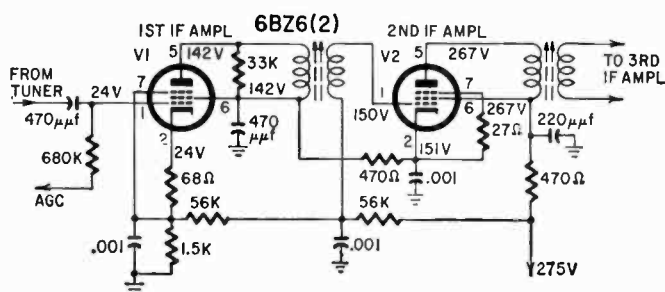

Fig. 203. Cathode does not have to be returned to ground. Grid-to-ground voltage is positive. Compare with Fig. 202.

defective, V2 will not operate. This might lead you to believe that V2 is defective when the trouble stems from V1. The significance of all this is that you cannot make voltage and resistance checks blindly. Such tests mean absolutely nothing unless you are sure of the circuit. For instance, checking between the control grid of V2 and ground would show B-plus on the control grid. This might lead you to suspect a shorted coupling capacitor – and might cause you to go to the time and expense of replacing it. Actually, a B-plus voltage on the control grid of V2 is perfectly normal – and should measure slightly less than that on the cathode of that tube.

Accustomed to servicing ac-dc radios, you may have come to the conclusion that most circuits are fairly similar. This does not apply to TV where each manufacturer may have made important design changes. As a matter of fact, do not expect different models made by the same manufacturer to be alike. Be safe – get a circuit diagram!

Realignment

With plate and screen B-plus voltages that are normal and

tubes that are good, and the picture shows the following symptoms, then realignment is suggested: poor sync; smeared picture; streaky picture; poor contrast; poor picture detail; improper tracking between sound and picture. Follow the manufacturer's alignment instructions or service notes when doing this job. (Poor picture and sound tracking mean that the best picture and sound do not come in at the same setting of the fine-tuning control.)

Misalignment of the if strip sometimes produces buzz, although there are many other receiver defects that also produce this symptom. These will be discussed later. If, in realigning the if stages of the receiver, you increase the amount of buzz, then, undoubtedly the realignment is not being properly done. Fig. 204 shows a representative if response curve. The audio and video

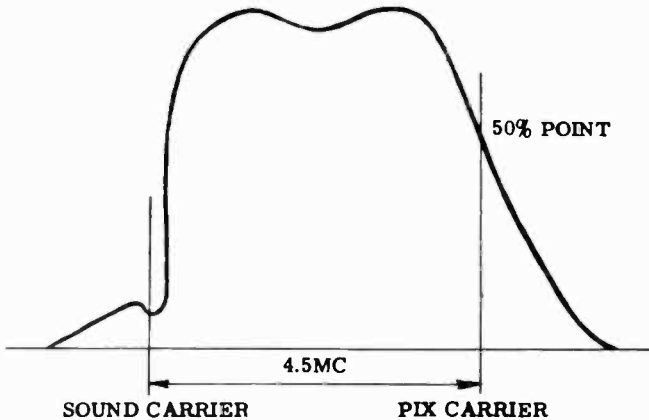

Fig. 204. Response curve showing proper relation between sound and picture carriers.

carriers are separated by 4.5 mc. Note that the video carrier is placed halfway up the slope of the curve. The sound carrier is almost all the way down the other side of the slope. Actually, the sound carrier should have a strength of no more than 20% of the video carrier at the input to the video detector.

Trailing whites

It is impossible to overemphasize the importance of correct alignment. Although experience may show that an if slug can apparently be rotated quite a bit before any effect is noticed, if you look at Fig. 205 you will see a condition of trailing whites.

This trouble is caused by placing the video carrier too far down on the slope of the IF response curve. The photo shows the effects of poor low-frequency transient response. Observe the horizontal wedges and note the lack of contrast. This, then, is a receiver condition whose only solution is realignment of the IF stages.

Insufficient contrast

Insufficient contrast is evidenced by weak-looking pictures on most channels, with the contrast control set in its maximum position. Generally, the trouble is due to one or more weak tubes, anywhere from the front end right up to the picture tube. Find the weak stage by injecting a signal from an AM signal generator, starting at the input to the first video amplifier and working back

Fig. 205. Picture and enlarged insert showing training reversal. This may be caused by improper positioning of carrier on response curve-slope.

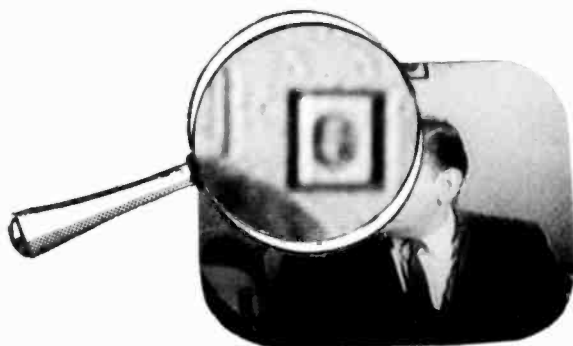

to the front end. This signal-injection method will produce bars on the screen. These bars may be vertical, horizontal or slanting, depending upon the particular setting of the frequency dial on your signal generator. The positioning of the bars is not important. It is necessary, however, to note the strength of the bars as you work your way back from the video amplifier grid to the antenna of the receiver. The bars should increase in strength as you go from stage to stage. Any stage that does not produce an increase in signal strength should be suspected (this does not, of course, apply to the video detector, since there is no amplification in a diode).

However, before signal tracing, carefully examine all the tubes from the front end of the receiver right up to the picture tube. Look for tell-tale signs of non-operation. Try to determine if all filaments are lit. (This is sometimes difficult to do with miniature tubes.) Use a dental mirror to help determine if the filament of a tube is lit. This device consists of a small mirror about 1 inch in diameter, mounted on the end of a long metal rod.

Quite often, a tube anywhere in the chain from the front end to the picture tube can be completely inoperative and yet a signal can get through, due to capacitances in wiring and tubes. The result is a weak signal with insufficient contrast.

Then try tube substitution or check all tubes from the front end to the picture tube, in a tube tester.

Delayed contrast

Sometimes you will receive a complaint that the picture gradually improves as the TV receiver is allowed to remain on. Not all tubes have the same amount of cathode heating time and if the delay is about $\frac{1}{2}$ minute or so, the problem is not serious. However, if the delay is longer, then one of the tubes starting from the front end to the picture tube (that is tubes in the tuner, video if or video amplifier section) has weak cathode emission. The technique for finding an inoperative tube, described in the preceding section, should be used here.

60-cycle hum

60-cycle hum generally appears as a single wide horizontal bar across the screen or bending of the picture. (Fig. 206). To determine the cause, first remove the antenna transmission line and short the receiver's input terminals. If the hum condition remains, then the trouble is definitely due to some trouble inside the set. Remove the last picture if amplifier tube. If the hum symptom disappears, then the fault is somewhere between the front end and the picture detector. If the hum remains, then it is caused by some condition between the picture detector and input to the cathode-ray tube.

Generally, 60-cycle hum is caused by a defective tube, with leakage or a short between heater and cathode. You can check by shorting the cathode of the suspected tubes to the chassis. If the hum bar disappears during this test, then the tube being tested in this way is defective and should be replaced. Make this test as quickly as possible, since shorting the cathode resistor increases the current flow through the tube and can damage it. This test cannot be used on tubes whose cathode is directly tied to the chassis.

Intermittent picture

In checking through the if stage, be alert for symptoms that can lead to an intermittent picture: cold solder joints; loose con-

nections; defective resistors, coils and capacitors. The fact that a resistor or capacitor or an if transformer looks good does not necessarily mean that it is. Turn the receiver on and watch the picture. Tap the chassis, gently, up and down from the tuner as far as the picture detector. See if you can observe the particular area where the tapping produces the intermittent condition. Tap (gently) each component in the localized area with an insulated tool, while watching the picture on the screen. Take plate voltage measurements while tapping components. Connect a vtvm (set to read dc volts) to the plate of the suspected tube and gently tap components while watching the needle on the meter.

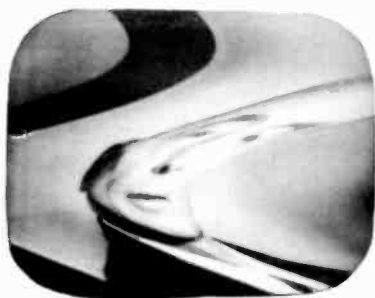

Fig. 206. A single bend in the picture is caused by 60-cycle hum.

Any tapped component that produces a jump in the meter reading should be checked further.

Also examine the light produced by heated filaments in all tubes from the front end to the detector. Any change in the glow of a filament indicates an intermittent condition.

Lead dress

The if stages of a TV receiver operate at a frequency sufficiently high to make the positioning of wires and components important. Whenever possible, replace components with identical parts. Examine all wiring before making a change. Defective wires in the if strip must be measured and replaced with wires of identical length in exactly the same position. Do not try to modify if stages, change them or make other design changes, unless you are following manufacturer's instructions. Even substituting a part that is not identical to the original may compel you to realign the if stage. This can be time-consuming.

Neglecting these precautions can lead to such troubles as weak or snowy pictures, bending, interference, regeneration and an

over contrasted picture. The whole idea in replacing components in the if strip is not to have to realign it.

No picture or sound

In intercarrier receivers, the sound takeoff is after the picture detector. The sound and picture travel together up to the output of the picture detector and, as a result, any defect in the front end or the if stage that affects the picture can just as well affect the sound. Thus, a defective tube anywhere from the front end



Video ifs, being stagger-tuned, are often left unshielded. Under-chassis mounting also shortens the required lead length to socket lugs.
(Chicago Standard Transformer Corp.)

up to the picture detector can cause complete absence of sound and picture. The raster, however, will not be affected. To determine if the trouble is due to a defective tube, turn the channel selector to the strongest channel and turn the contrast control to maximum. If you are able to get any evidence of sound and picture, then the trouble is definitely due to a defective tube in the front end or in the if stages.

If the receiver you are working on is one of the older types—that is, it is split carrier—then sound is generally taken off immediately following the front end. In such a receiver, loss of picture and sound is due to tube trouble in the tuner and not in the if stages.

Picture oscillation

This condition is often confused with ghosts and sometimes the service technician will spend considerable time making antenna changes when this trouble is due to some condition inside the receiver. The symptoms of picture oscillation and ghosts are similar. Look for the small differences that distinguish the two.

A ghost is a complete picture. That is, small objects and large objects in the picture will have a ghost pattern. In picture oscillation, however, the lines that resemble ghost lines follow small objects and will generally not be found after large objects. Look carefully at the picture on the screen. If the large object is clean and sharp and small objects have fine lines following them, then

the trouble is due to oscillation. (Oscillation is also known as positive feedback or regeneration).

This trouble is sometimes caused by tube shields which have been removed and which have not been replaced or by shields which do not make contact with the chassis. Turn the receiver on and watch the picture carefully. Put your hand on each of the if amplifier tubes in turn, and note the effect on the picture. If the lines disappear when you touch a particular tube, try replacing that tube with a new one.

Try substituting new tubes in the if amplifier. Also, the trouble can be caused by defective bypass capacitors in the if stages. Try shunting these with a known good capacitor.

To locate the culprit responsible for if oscillation place a shorting wire across the antenna terminals. Connect a vtvm across the video detector diode load resistor with the meter set to read a maximum of 1 volt dc. With the receiver turned on, the meter should read 0.6 volt or less. If it reads more than this and if the needle has a tendency to fluctuate, then you definitely have a condition of oscillation.

The trouble can also be caused by some slight misalignment of one or more of the if stages. In stagger-tuned if systems, each if must be tuned to a particular frequency to produce the best picture. If two or more stages are misaligned and their frequencies are brought closer together, there is the possibility of feedback from one stage to another.

Make the changes suggested previously while watching the meter. Any change made that reduces the reading to normal is an indication that the cause of oscillation has been found. Watch the meter needle and very carefully move the lead wires in the if stage. Improper lead dress in an if system can produce oscillation.

Caution: If the if stage is misaligned, it can produce an overloaded picture. It can produce a condition of oscillation. The if stage can be overpeaked, thus increasing the gain. As a result, the picture will be excessively dark. If the condition improves when the antenna is disconnected from the receiver, then the alignment of the if stages will have to be checked.

Sound bars in the picture

Sound bars in the picture can be caused by misalignment of the sound traps in the if amplifier system. Before you attempt to align the sound if traps, it is important to make sure that they are

the ones causing the trouble. Try placing your hand near each of the sound traps, in turn. If the proximity of your hand improves the picture when your hand is near a particular trap, then that trap needs realignment.

Now take a single shorted turn of wire slightly larger than the diameter of the sound if trap. Hold this wire with some sort of insulating material and keep your hand away from the coil. Place the shorted turn over the trap and note the condition on the screen. If the sound bars decrease in intensity, then that trap has to be realigned.

You will not necessarily need test equipment to align a sound trap. Simply watch the bars on the screen while adjusting the slug of the trap. Most often you will not need to make more

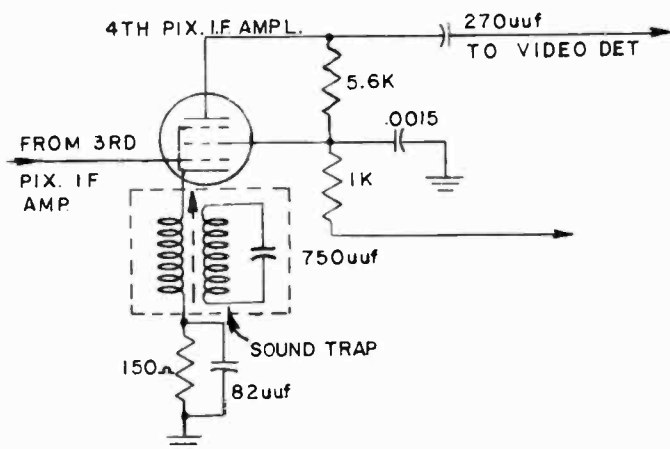

Fig. 207. The parallel-tuned circuit is a sound trap. If current were allowed to pass through the inductance, the Q of the tuned circuit would be lowered.

than a minor adjustment to the trap. Fig. 207 shows a typical sound if trap.

Poor high-frequency response

Misalignment of the if transformers or a badly misadjusted sound trap in the if section can cause a loss of fine picture detail. In Fig. 208 we have a photo showing the loss of high-frequency response as evidenced by the lack of definition in the vertical wedges. For best possible picture, the vertical lines of the wedges should be fairly distinct right to the outer edge of the bull's-eye.

Time-saver

If you have no sound or picture and want to determine whether the if stage is operating properly, scratch the control grid pin of each if amplifier tube with a screwdriver. This should result in flashes on the screen, and you should hear clicks in the speaker. Any stage not producing these symptoms has a defect in it. Another similar technique is to short temporarily the grid of each if amplifier tube to the chassis. This will also produce flashes on the raster and clicks in the speaker. However, this test must be done very rapidly to prevent damage to the tubes. Touching the

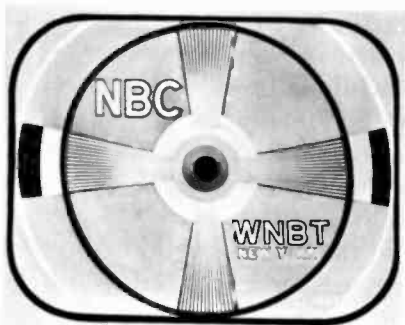

Fig. 208. *Loss of fine detail in the vertical wedges is an indication of poor high-frequency response.*

test probe of an instrument to the plate or to the control grid (with the meter set to read the correct voltages) should also produce a click in the speaker or a flash in the picture. The advantage of using a voltmeter is that it will give you a voltage reading at the same time.

Voltages in the if stages

There are three types of voltages you will encounter when running checks on if stages: (1) The dc voltages present on the plates, screens and cathodes of the various tubes. (2) Another dc voltage in the form of an agc bias. This voltage is dependent upon signal strength. A strong signal raises the negative agc bias on the grids of the if tubes. The agc bias is lower for a weak signal. (3) The signal voltage as it is passed from stage to stage. Whenever you service receivers, it is always well to measure bias voltages on if tubes as received from the agc circuit. In this way, you will learn what the average agc bias should be for typical receivers and typical channels in your particular area.

In a fringe area, you may wish to increase the gain of the if system to get a presentable picture. One way of doing this is to make a tube substitution and to use tubes having a higher gain.

When making such substitutions, make sure that the pin connections are identical with the original or it will be necessary to make wiring changes. Check the tube manual to make sure that the possible increase in screen and plate current of the new tube does not place too heavy a burden on the power supply. It may be necessary for you to change the value of the cathode bias resistor since the new tube may require a different bias voltage.

You can increase the gain by shifting the plate and screen voltage points to a higher voltage tap on the B-plus line. You must be careful not to exceed tube ratings. It is possible that this will shorten tube life. If you cannot connect into a higher B-plus point, try shorting the plate decoupling resistors. These are used to prevent regeneration, but it may be possible to remove or short them without producing this condition.

Another method for increasing the gain of an if stage is to retune the if section so that you do not utilize the entire bandpass. This will be at the expense of picture quality but it may be better to secure such a picture rather than one that is very weak.

Note that we have not said much about agc even though the if stages are agc-controlled. The subject of automatic gain control is so important that the material will be covered in a completely separate chapter — Chapter 4. At that time we will learn how agc voltages affect the front end and the if stages.

Coupling in if stages

We have various types of interstage coupling in television receivers. Many receivers use a single tuned if transformer, as shown in Fig. 209. The transformer has a single polyiron slug and either the primary or secondary is tuned by it. The untuned coil is sometimes said to be fixed-tuned. The double-tuned type has two slugs — one for the primary and the other for the secondary. The third type of coupling (impedance coupling) has a tuned coil but uses a capacitor to transfer the if signal into the next stage.

Each of these types has advantages — and disadvantages. The single-tuned type has fewer adjustments, making alignment much easier. However, it is much more difficult to obtain the proper bandpass with a transformer of this type.

If transformers are simple enough devices but that doesn't stop them from causing trouble. The slugs in the transformers should be secure and should turn only when a definite turning force is applied to them (such as that supplied by an alignment tool). If they are loose, vibration can cause detuning. This applies

even if the set is installed in the home, since outside traffic or even persons walking across a floor can produce slug vibration. A drop of cement (such as Duco) should be applied if the slug is loose.

Slugs can break, chip or fall off the alignment screws on which they are mounted. If no setting of the slug affects picture quality, it is possible that either the slug or the coil winding is defective.

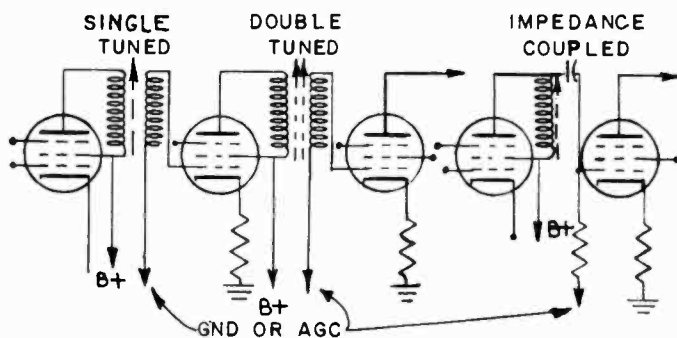

Fig. 209. Types of coupling used between video if stages.

A resistance check across the winding will soon establish whether the coil is open.

Audio tube as voltage divider

Earlier we discussed a situation in which the operation of an if stage is completely dependent upon the good behavior of a preceding tube. In that case the trouble is confined to the if strip, and so might not be too difficult to find.

A much more complicated circuit is shown in Fig. 210. The third if amplifier tube is in series with the audio output tube. These two tubes are now acting as a voltage divider for the B-plus system. If the audio output tube should become defective, the result could be a loss of picture. If there is a loss of picture, the first thought that flashes across the technician's mind is that the defect must exist somewhere in the tuner, video if, video detector or video amplifier. This would be a logical conclusion were it not for the particular circuit design used. Since a defective sound output tube would mean no sound from the speaker, all the symptoms point to those components carrying both picture and sound. This would be the chain of circuits just mentioned.

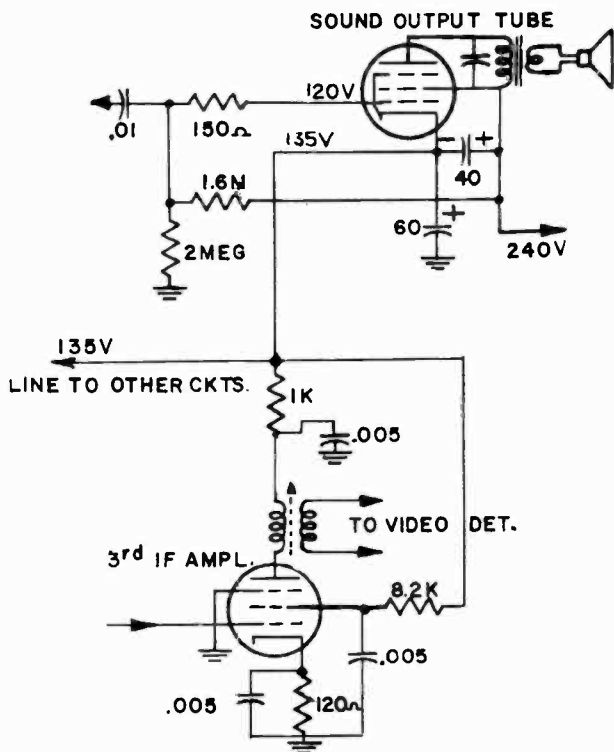

Fig. 210. A typical stacked B-plus circuit. Here the third video if is shown as one of the circuits using the audio output tube as a voltage divider to supply +135 volts.

Although we show just one if stage in Fig. 210, it is not uncommon to have two or three stages in series with the audio output tube.

Most receivers use at least three if tubes. Of these three tubes, generally two (and sometimes three) are identical. Sometimes you can make a quick repair just by interchanging video if tubes.

Time-saver

If a complete open in a video if stage (defective tube, open if transformer, open cathode resistor, etc.) is suspected, you can make a quick check as shown in Fig. 211. Set the channel selector to the strongest station and turn the contrast control to full maximum. Connect a coupling capacitor between the plate of the preceding stage and the control grid of the tube in the following stage. If the picture strength increases, an inoperative if stage is

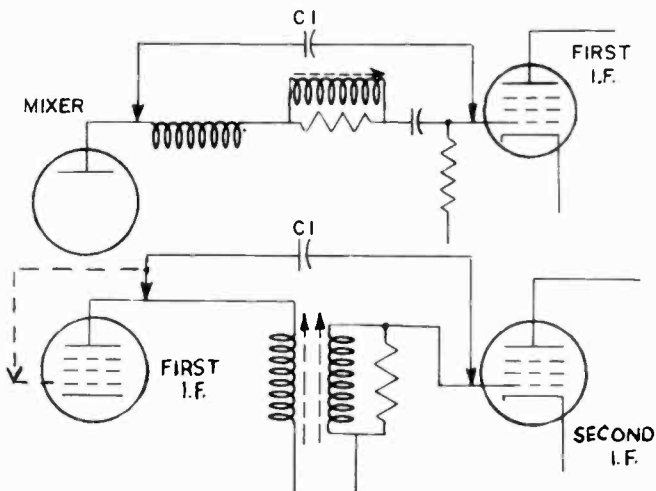

Fig. 211. Capacitor $C1$ can be used to bridge a defective stage to determine an if open-circuit condition. Typical value for $C1$ is $100\ \mu\text{f}$.

clearly indicated. This technique will work only if the signal is strong enough. If you suspect an open circuit in the first if stage, connect the capacitor from the plate of the mixer to the control grid of the second if stage.

Wiggling in the picture

Where the picture seems horizontally unstable and shows as a shifting movement accompanied by trailing whites, the trouble is due to heterodyning action between the sound and the picture carriers that pass through the video detector and amplifier stages. The resulting beat signal modulates the scanning beam in the picture tube. This can happen if the if stages are aligned so that the sound carrier is further up on the slope than the 5% point. (The sound carrier is often placed at the 2% point.) Sometimes this trouble is due to improper tuning of the receiver. If careful adjustment of the fine-tuning control (on more than one channel) fails to eliminate the difficulty, the video if stages will have to be realigned. Sometimes customer tampering with the if transformer slugs will cause this trouble.

Picture fades in and out

Sometimes confused with flutter, this trouble is caused by defective keyed agc or slow agc. If the contrast control requires fre-

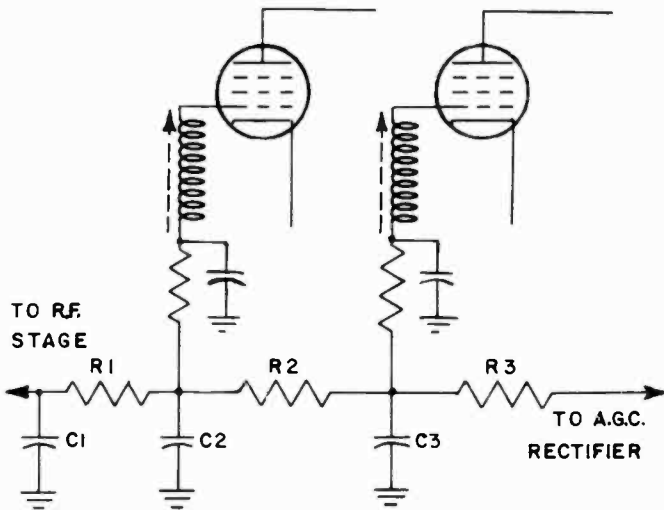

Fig. 212. Intermittently defective resistors or capacitors can cause changes in contrast and picture quality.

quent resetting and the picture seems to move from light to dark on all channels, some component in the agc system may be defective. A changed-value of agc filter resistance or an open agc filter capacitor can cause this trouble (Fig. 212). Some receivers use filament bypass capacitors as shown in Fig. 213. Check these for opens. A quick check is to shunt these with known good capacitors of the same value. If the trouble disappears, solder a new capacitor into place. (A value such as .005 μf is typical.)

Lines similar to ghosts

This symptom is sometimes mistaken for ghosts. Lines appear in the picture but most often after small objects. This is a symptom of oscillation in the video if. Sometimes streaks will appear in the picture, giving rise to the impression that the trouble is caused by outside interference.

Make sure that all shields (when used) are securely seated and grounded. Check the decoupling circuits (Fig. 214) used in video if stages. Shunt the decoupling capacitor with an equivalent unit. Try shunting a capacitor between screen grid and cathode (not ground) of each video if stage. Make sure that the lead dress of if transformers has not been disturbed. Keep tube plate and grid leads away from each other. If the if transformer is shunted by a resistor, be certain that the resistor has not opened or increased in value.

Checking video if transformers

A typical video if transformer having primary and secondary windings is shown in Fig. 211. If the resistance of each winding is much less than 1 ohm, an ohmmeter should indicate a complete short when set to measure low resistance across them. If, in making resistance checks, the primary shows an infinite resistance reading, it is open. This can result in tube damage since the screen receives its normal voltage, while the plate does not. In

Fig. 213. A capacitor (C1) is sometimes used to bypass rf from the ungrounded side of the filament.

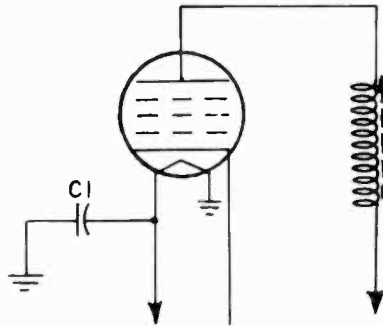

resistance checking the secondary, if you read the value of the shunting resistor, then the secondary winding of the if transformer is open. There is no way in which you can check the value of the shunting resistance except by disconnecting one side of it and then measuring across the resistor with an ohmmeter.

To make resistance checks on if transformers, you need not pull the chassis. If the video if tube is a pentode, simply remove the tube and insert the test prods into plate and screen pins of the tube socket. The ohmmeter will be across the primary of the if transformer. If the transformer secondary is connected to ground, you can measure the resistance of the secondary by inserting the ohmmeter test prod on the grid-1 pin and placing the other test lead on the chassis.

The same tests can be made by using voltage measurements. If plate voltage is absent, but screen voltage is present, the primary of the if transformer is open. If the primary is shunted by a resistor, voltage will appear at the plate, but will be much lower than at the screen. Plate and screen voltages should be practically identical.

Replacing video if transformers

You should always use identical transformer replacements for

two reasons: (1) Physical. A substitute transformer may not fit, you may have to drill new mounting holes, or it may interfere with adjacent parts. (2) Electrical. Not all if transformers are alike. Some use a primary winding only, with R-C coupling in the grid circuit of the following stage. Some transformers are double-tuned, others are bifilar-wound. There are many varieties of transformers. Use the replacement unit recommended by the manufacturer for the particular model you are servicing.

Faults due to other circuits

The video if amplifier can operate properly only if it has the correct dc voltages. A weak picture, for example, could be due to insufficient gain in the video if amplifier, but in itself the video if amplifier might be in perfectly good order. In this case, the

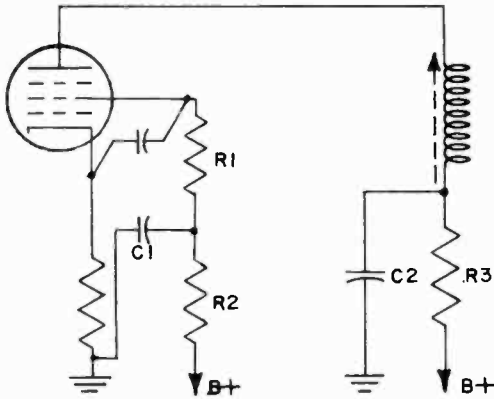

Fig. 214. Decoupling filters are formed by C1-R2 and C2-R3.

trouble might be due to decreased B-plus voltage possibly caused by a weak low-voltage rectifier tube. Although the symptoms may point to the video if amplifier, all that is needed is a voltage check. By making plate and screen voltage checks, you can easily determine if the video if or the low-voltage supply is at fault. If all plate and screen voltages are lower than normal, then the trouble must be in a source that is common to the video if amplifier — namely, the low-voltage power supply. If, however, just a single video if tube shows reduced plate or screen voltage but the voltages on the other video if tubes are normal, then the difficulty lies in the video if stage having the reduced voltage.

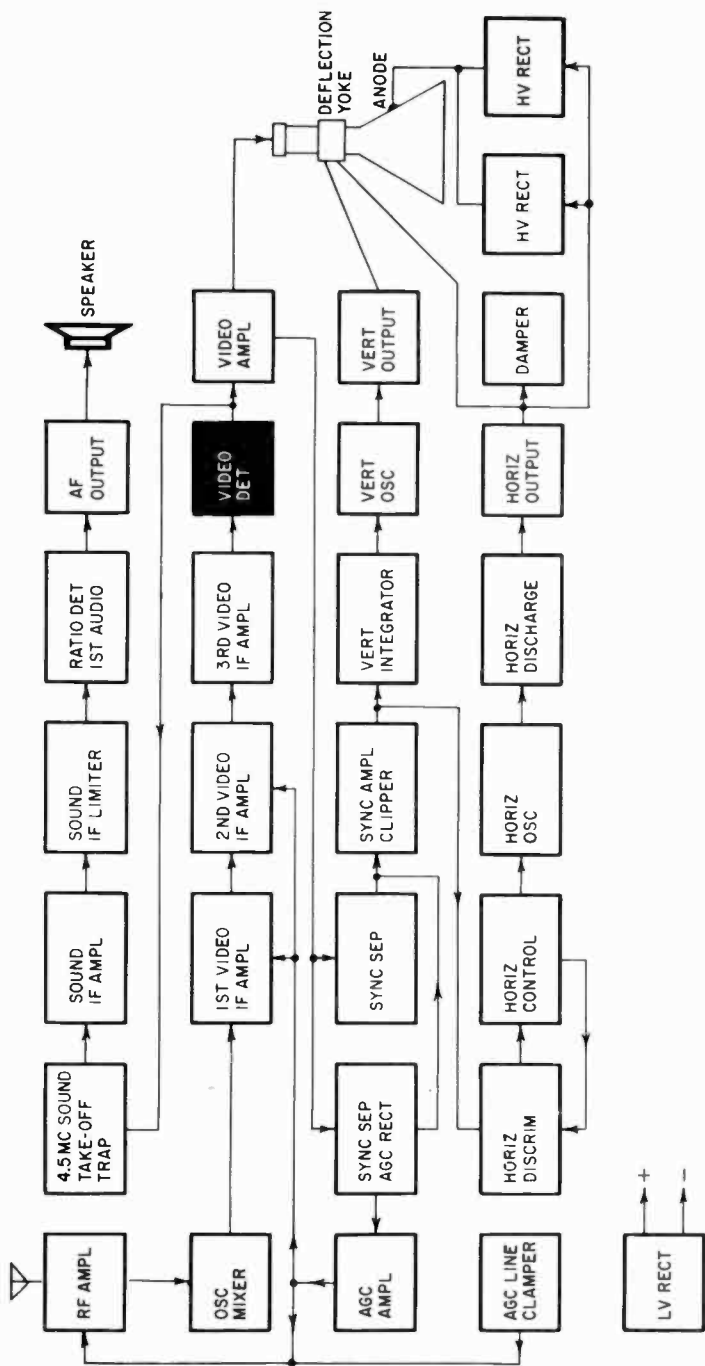

Fig. 301. The video detector can be considered as the half-way point for the signal.



picture detector defects, chapter 3

A COMPLETE check list of every possible trouble that could exist in a television receiver would seem a most desirable thing. The truth of the matter is that such a list could be compiled, but never completed. Every model of every television receiver develops some troubles that are peculiar to it alone. And since every television manufacturer makes a large number of models, such a list would be quite extensive. The problem is further complicated by the fact that design changes are often made in television receivers after the receivers have been on the market.

In this chapter, we are going to cover the most common defects to be found in video detectors. Our purpose is not to highlight a particular defect found in one model of one manufacturer, but rather to give information that covers the great majority of receivers.

The part of the television receiver we are going to study next is shown in Fig. 301.

What the video detector does

In modern television sets, video detectors are required to pass the complete composite video signal. This includes the video signal, the various sync and blanking pulses and also the audio modulation. For this reason, a defect in the video detector can result in trouble in the picture, in the sync or in the sound. (This does not apply to split-sound receivers in which the sound is taken off at some point ahead of the video detector.)

The video detector has a double job. Since the video signal is amplitude-modulated, the diode works as a detector (or demodulator). The output of the video detector must have a sufficient amplitude to swing the grid of the first video amplifier tube.

The video detector also acts as a heterodyne device or mixer. It does this by beating together the picture and the sound carriers. Since these two signals are separated by 4.5 megacycles, the output is a signal having a center frequency of 4.5 mc. This is the intercarrier sound which can then be fed into its own if strip.

Video detector components

A typical video detector circuit using a semiconductor diode is shown in Fig. 302. The dashed lines (when shown in a circuit diagram) indicate that the video detector circuit is enclosed in

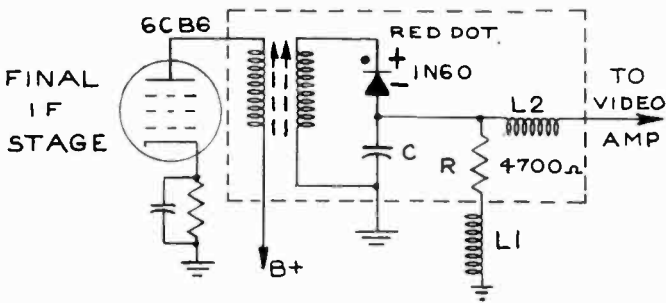

Fig. 302. Video detector circuit. The crystal polarity may be indicated in many ways; some are shown. The dashed line indicates components within a shield can.

a metal shield can. The signal is coupled from the final if stage to the diode by a double-tuned transformer. The double arrows indicate that both the primary and the secondary are tuned. The diode itself may have a variety of markings (only one of which is actually used). Thus the diode may be marked cath or with the letter K (abbreviation of cathode); it may be marked plus (or have a plus sign); it may be marked minus. Sometimes a stripe is printed around one end to indicate the cathode. The negative or minus terminal of the diode corresponds to the cathode of a diode tube while the arrow portion corresponds to the plate of that diode. This means that the rectified (or detected) video signal current flow will be from the top of the diode (the straight line portion) to the bottom. At this point, the dc signal current is blocked by capacitor C and is forced to flow down through the 4,700-ohm diode load resistor to ground.

Capacitor C is a bypass unit. Its job is to remove the intermediate-frequency portion of the signal. If capacitor C should open, an excessive amount of voltage (signal voltage plus if voltage) might get through to the video amplifier tube and overload it. If capacitor C should be larger in value than that actually needed, there would be a loss of signal. The final result would depend on how much of the signal would be bypassed. It could lead to a weak picture with poor sync.

The detector load resistor is usually less than 5,100 ohms and in this case is shown as 4,700 ohms. Since the signal voltage is developed across this resistor, the picture will disappear if this resistor should open or be disconnected from the circuit. This is true of all channels. The raster, however, will remain.

Do not confuse improper focus of the CRT beam with if and video circuit defects. Dirty CRT and safety-glass can also blur the individual raster lines.



The correct value of load resistance is important. If the load has too high a value, fine picture detail will be lost, the picture will have poor definition and there may be smear. However, if you are working in a fringe area, you might experiment with making small increases. Thus, if the load is 4,700 ohms, try raising it to 5,100 ohms. However, it is important to make sure that this change does not adversely affect other channels being received by the set. Of course, if the load resistance should be decreased in value, the picture might disappear almost completely. The general complaint (in cases of lower-than-normal load values) will be a weak picture, poor contrast and possible rolling and tearing (critical sync).

L1 is a shunt peaking coil. It is in series with the diode load resistor. At low video frequencies, the reactance of L1 is comparatively small and practically the entire diode load consists of resistor R. At high video signal frequencies (important for fine detail in the picture), the reactance of L1 is comparatively high.

The inductive reactance of L_1 (measured in ohms) is in series with R , and increases the total value of the load. Now the higher video signals (in the region of 2.5 to 4 mc) will develop about the same amount of voltage for driving the video amplifier as do the lower video frequencies.

With L_1 open, the video signal is "lost" and there is no picture on any channel. The raster is not affected. When replacing this peaking coil, it is essential to use an exact replacement. If the inductance of the coil is too low, the higher video signal frequencies are grounded, and there is a loss of definition in the picture (little or no fine picture detail).

However, the peaking coil is often wound on a resistor. The resistance of the coil is 20 ohms or less. That of the resistor is generally in the region of 5,000 ohms. The total resistance of this combination wired in parallel is somewhat less than 20 ohms. If the shunt peaking coil should open (but with the resistor still in the circuit), the effect would be to increase greatly the value

Peaking coils may not be encapsulated in a protective compound. (Chicago Standard Transformer Corp.)



of the diode load. The result would be a picture with poor detail and one that would seem excessively bright.

Coil L_2 in Fig. 302 is a series peaking coil. In some receivers it is wound on a resistor (usually less than 22,000 ohms) and in other sets just the coil alone is used. Whether or not the peaking coil is wound on a resistor, its value as checked with an ohmmeter should be 20 ohms or less. A defect in this peaking coil can lead to poor contrast or poor definition, or possible loss of picture.

The resistor on which peaking coils are wound (such coils are used in the video amplifier as well) has a double purpose. The resistor serves as a coil form. This is not its primary job. Coils (especially those that are air-wound) have a tendency to resonate at some particular frequency. Now we do not want L_2 to push up or emphasize a particular frequency. Rather, we want it to

boost a fairly wide band of frequencies. To do this, L2 must have a low Q. The Q is lowered by putting a resistance across the coil.

Without a resistor the coil's inductance must be such that its resonant frequency is outside the frequency range of the video signal.

Peaking coils are designed for particular TV receivers and manufacturers' replacements (or equivalents) should be used. And while on the subject of replacing peaking coils, note that it is advisable to mount series and shunt peaking coils at right angles to each other to keep the magnetic field of one coil from inducing a voltage into the other. Peaking coils should be mounted away from the chassis. Stray capacitance cannot be seen, but that does not prevent it from bypassing the higher video frequencies. This would reduce the fine detail in the picture. Attention to these items — although they do seem minor — means the difference between a picture of good quality and one that is simply passable.

Time-saver

To determine if the peaking coils (or the resistors on which they are wound) are open, shunt the unit with a clip lead. If the picture returns to the screen, peaking-coil trouble is indicated.

Vacuum tube detector

Fig. 303 shows a typical diode detector circuit. The diode is one-half of a tube, the other half is a pentode amplifier for the last if stage. Comments and suggestions made for the semiconductor detector apply here. In this instance both the detector and last if amplifier circuits are related through the use of a common tube.

To produce a decent picture, the output of the detector, whether it is a tube or a crystal, must supply at least 1 volt peak to peak, preferably more. Generally, the output ranges from 1 to 5 volts, peak to peak.

Checking video detector crystals

A crystal can easily be checked with an ohmmeter. Disconnect one side of the crystal. Connect the test leads across the unit and take a resistance reading. Now, transpose the leads. You now have two resistance measurements, one of which should be very low and the other very high. In a typical unit that is in good condition, the low resistance (often called the forward resistance) reading ranges somewhere between 50 to 100 ohms. The resistance

reading obtained by transposing the test leads should result in a resistance having a value of 100,000 ohms or more. (This is sometimes called the back resistance.) The ratio of high to low resistance should be at least 1,000 to 1, preferably more. This means, that for every 1-ohm resistance in one direction, there should be 1,000 ohms of resistance in the opposite direction. If this condition does not exist, replace the crystal.

The ratio of resistances (forward to back resistance) of a crystal must be much higher for a good picture than for good sound.

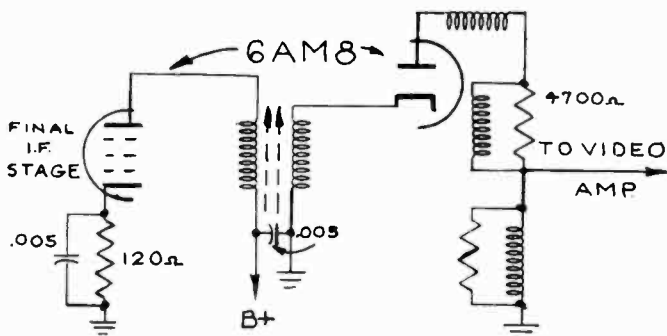

Fig. 303. This detector diode is half of a pentode-diode vacuum tube.

It is entirely possible for a defective diode to produce good sound and yet the resistance ratio of the crystal might not be high enough to permit a good picture to come through. As a typical case, a diode might have a resistance measuring 50 ohms and, with the meter leads transposed, might measure as low as 500 ohms. A condition such as this in the crystal will result in a complete absence of picture but not necessarily an absence of sound. In cases where the symptom is moderately good sound but no picture, it is possible for the diode to be at fault. Do not assume that the crystal diode is good because it *looks* good. It is possible for a crystal detector to change its resistance during the time it is in operation in the receiver.

Precautions in handling crystals

Observe the polarity of the diode. Make sure that it is wired in exactly the same manner as the old one. If wired in backward, the picture on the screen will be negative and you will not be able to keep it in sync.

Crystals are temperature-sensitive devices. The heat of a solder-

ing iron can destroy them or alter their characteristics to produce defective receiver operation. When installing one, use a thermal shunt. A pair of pliers (Fig. 304) makes a good thermal shunt. Hold the diode so that the jaws of the pliers grip the lead and that the pliers are between the soldering iron and the body of the diode itself. When soldering, do not keep the iron on the pigtail for too long a period of time.

When replacing a semiconductor diode, be sure to mount it away from any part that gets warm in operation. Keep away from any tube generating heat. If the video detector is enclosed in a metal can, be sure to replace the can after you have installed the new detector. Sometimes the video detector circuit is quite com-

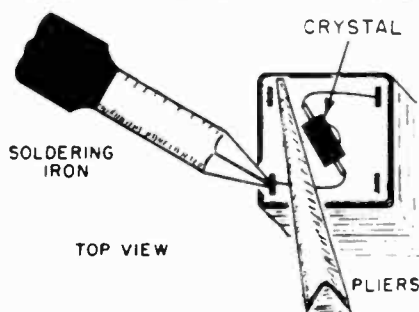

Fig. 304. A pair of long-nose pliers can be used as a thermal shunt to prevent detector crystal from being damaged by excessive heat.

pact and the clearance between the detector leads and the metal can is extremely small. If the receiver operates well with the shield can removed, but fails to operate or operates poorly when the shield can is replaced, the shield may be shorting some portion of the detector circuit. If necessary, insulate the diode leads with spaghetti or line the interior of the can with fish paper (or any other insulation) held in place with tape.

Crystal detector troubles

You can get a variety of symptoms, depending exactly on how defective the crystal really is. If the crystal is open or short-circuited, there will be a complete absence of picture and sound. The raster will not be affected. If the diode is very weak, the picture will be missing, but it is possible that some sound may come through. A defective diode can also result in critical or no sync, or a picture having smear. If the picture is good but the sound is weak, it is extremely unlikely that the crystal is at fault.

Overloading

The semiconductor detector in a television receiver has its

advantages and its disadvantages. It is light in weight, it is small and it consumes no power. For servicing purposes, however, the vacuum tube does have a few points of superiority. You can often locate a defective tube simply by inspection. The tube can be checked quite easily and quickly in a tube tester, or, failing that, a quick substitution test can be made. Unfortunately, these servicing conveniences do not apply to the diode. They must be handled carefully, and replacement is usually not an easy job. As we have mentioned earlier, quite often the diode is mounted

Semiconductor diode sealed in glass allows internal parts to be viewed. (Clevite Transistor)

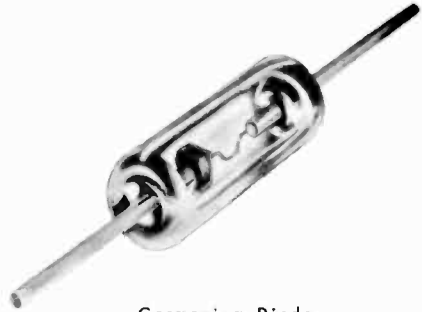

Germanium Diode

together with the remainder of the detector components in a shield can. Removing the diode detector, checking it and replacing it means pulling the chassis. This is time-consuming. We recommend that you become acquainted with the symptoms produced by a defective crystal so you can recognize them. Replacing a crystal that is subsequently found to be good is, obviously, a complete waste of time.

A diode can deteriorate. In plain English, this simply means that a diode, just like a vacuum tube, can gradually become weaker in service. Many service technicians feel that because the diode has no heater it should remain in perfect operation for at least the life of the receiver. This is just an assumption and a mistaken one. The output voltage developed across the load resistor can decrease because of the crystal. The strength of the agc voltage (which depends on the strength of the detected signal) will also decrease. As a consequence, stages that are controlled by the agc voltage (usually the rf and if stages) will have a lower agc voltage. The gain of those stages will increase. If the agc controlled just one tube, the trouble might not be so serious but, since the agc is fed to a number of tubes, the servicing problem becomes important. Because they no longer have the correct bias, the increase in signal level can overload the if tubes. Even if the rf

amplifier tube in the front end is agc-controlled, it will generally not overload since this is a point of very low signal strength. The same applies to the first if tube. Usually it is the second and more often the third if stage that becomes overloaded. The symptoms produced by a defective diode resulting in an overloaded if stage are shown in Fig. 305.

The condition of overload just referred to is a characteristic of strong-signal areas. In a fringe area, the agc control in the



Fig. 305. A detector circuit defect can cause an overloaded picture as well as loss of sync.

receiver is set for a minimum value anyway. This does not mean that a diode with lowered output is satisfactory for fringe areas. It does mean that the final symptoms may be somewhat different. In a strong-signal area, reduced output from the crystal means that the agc circuit is not permitted to function properly. In a weak-signal area, the defective diode has much less effect (if any) on the agc circuit. The output from the diode is still lower — and the signal developed across the diode load resistor may be too weak to operate the video amplifier tube properly. The result will be a very weak picture (loss of contrast) or possibly no picture at all. Thus, lowered output from a diode can result in different symptoms, depending on location.

If in a strong-signal area and you get the symptoms shown in Fig. 305, make a further check before pulling the receiver. Tune in a strong station and observe the picture. Disconnect the antenna leads and insert the attenuator network described in Chapter 1. If the picture improves, then a condition of overload is definitely indicated. Another technique is to keep the antenna connected and tune in a weak station. The symptom shown in the photo should disappear but the picture itself should be weaker than normal for that particular station.

Diode performance

Crystal diode performance is important, especially so in fringe

areas where optimum performance of all circuits is essential to produce a moderately fair picture. Do not assume that all diodes, even of the same type, are identical.

One of the ways in which you can test a diode is by substitution. And even here just the simple act of substitution is often not enough. It is much better to run a test on the diode performance. To judge the merits of various crystals, connect a vacuum-tube voltmeter (set to read low dc volts) across the diode load resistor (Fig. 306). Somewhat earlier we mentioned that the peak-to-peak voltage of a video signal should be at least 1 volt, prefer-

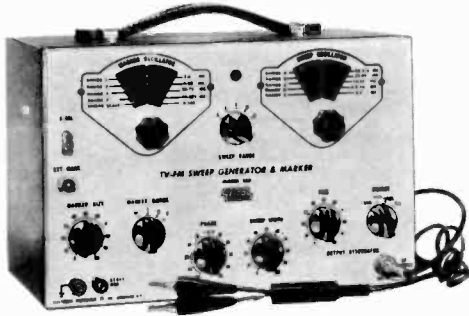

TV-FM Sweep Generator is used with a scope to present visually the response curve of the if band width. (Electronic Instrument Co. Inc.)

ably more. The vtm will read approximately 30% of this amount. For example, if the actual peak-to-peak voltage is 6, the meter will read about 2 volts. As a general rule of thumb, then, multiply your meter reading by 3 to learn the approximate value of the peak-to-peak signal. A better method is to use the vtm to measure the amount of agc voltage developed. If the receiver has an agc test point, connect the vtm between this test point and the chassis of the receiver. When making this test it is always best to use a steady signal such as that supplied by a test pattern. When running a performance test of this nature, do not readjust the receiver controls since this will make the test of no value. Make a record of typical values of agc voltages for all channels, if possible. Then, when servicing other receivers, you will have a guide for determining if all circuits, from the front end up to the video amplifier, are working correctly. However, you must make some allowances, for not all receivers provide the same amount of gain in the rf and if amplifier sections. Nevertheless, the information is of value since you will be able to establish a minimum desirable agc voltage for your particular area.

Not all crystals are pigtail types. If the diode is mounted in a holder, try rotating it to see if you have improved contact.

Checking intermittents

An intermittent picture means that some component somewhere between the antenna and the picture tube (and sometimes the picture tube itself) alternates between working and not working. To help localize the defect, use the picture detector as a dividing point and try to determine if the trouble precedes the detector or follows it. Use the hookup shown in Fig. 306.

Turn the receiver on. Disconnect the antenna and connect a modulated rf signal generator to the input terminals. Select a

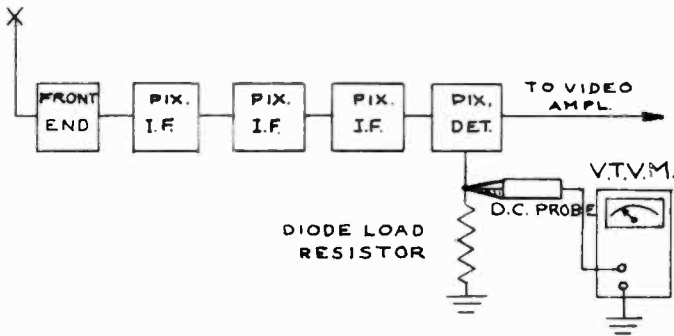

Fig. 306. Video detector output voltage measurements should be made across the diode load resistor.

frequency that produces a number of black bars on the screen. Adjust the attenuator on the signal generator so the vtvm reads about 1 or 2 volts dc.

If the meter reading fluctuates, then the intermittent is between the antenna and the video detector. If the needle remains steady, do not assume immediately that the intermittent follows the detector stage. With the vtvm connected as shown in the diagram, gently tap all tubes, capacitors, and resistors with an alignment tool, at the same time watching the meter. Any component (when tapped) which produces a meter fluctuation should be checked further. The trouble is not confined to resistors, capacitors, coils and tubes. It can be caused by poor soldering or a broken wire.

If the meter reading remains steady and there is no fluctuation after a period of time (at least $\frac{1}{2}$ hour) and probing with an insulated tool produces no results, then it can be assumed that the intermittent follows the picture detector.

Sometimes the intermittent occurs only after the receiver has been in operation for quite some time. It is entirely possible that the difficulty is being caused by some overheated component. Removing the chassis from the cabinet may provide enough ventilation to stop the trouble. Try pointing a heat lamp at the if section of the receiver. Be careful not to get any particular area excessively warm (run this check with the receiver turned on). The objective here is to heat components, but not to the extent of melting wax out of capacitors.

Vacuum-tube video detector

Many of the troubles that we have been discussing with respect

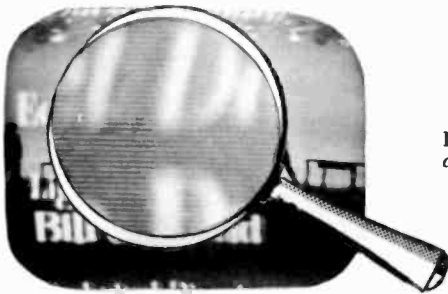

Fig. 307. Bend in picture is caused by small change in detector operation.

to the crystal detector are also applicable to the tube. If you suspect the vacuum-tube video detector, make a substitution test or run a check on the tube in a tube tester.

Vacuum-tube video detectors are subject to one trouble that you will not encounter in crystal detectors. If there is leakage between the cathode and the heater, this will result in hum modulation on the picture-tube screen.

Horizontal picture hook

The photo in Fig. 307 is an example of picture hook due to a defective crystal. This trouble is caused by incorrect horizontal sync action produced by sync compression due to a faulty diode.

A normal waveform as seen at the output of the video detector is shown in the photo in Fig. 308. Please compare this picture with that illustrated in Fig. 309. The video signal in the lower part of the waveform has not changed its amplitude, but you can easily recognize the reduction in size of the sync portion of the composite video signal. If the compression of the sync pulses is very severe, the picture will fall out of horizontal sync.

Picture smear

A defective crystal can produce a smeared picture. Somewhat earlier we mentioned that a crystal should have high resistance of at least 100,000 ohms. This means that the secondary of the last if transformer (Fig. 302) has a comparatively light load across it. But this condition is no longer true if the crystal resistance is lowered. A heavier load is imposed on the transformer, and it detunes the transformer. The result is just as though you had rotated the tuning slug of the transformer. This produces a condition of smear as shown in Fig. 310.

The important lesson to learn from this is that, although smear is a common indication of misalignment, it doesn't necessarily

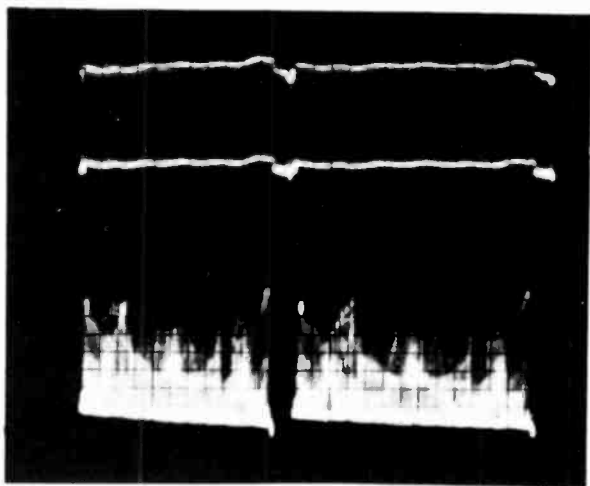

Fig. 308. Normal waveform across video detector as seen on scope with 30-cycle sweep.

follow that the if stages are misaligned. A quick resistance check of the crystal will soon reveal whether the smear is due to a defective diode or to misalignment.

Picture, no sound

TV sound is sometimes taken from the output of the video detector as shown in Fig. 311. If the picture is good and remains in sync, but sound is missing, then the trouble can be in any one of the three components (C1, C2, and L1) leading to the input of the sound if. (A more complete analysis of sound problems is contained in Chapter 10.) C1 is a bypass. Sound and pix will be missing if this capacitor is shorted. The value of C1 is quite small

(generally less than $10\ \mu\text{f}$) and it should not be replaced with one of higher value. Any substantial increase in the capacitance of C1 will lead to weak sound. If C1 is leaky, sound will be lost, the amount of loss depending upon the amount of leakage. Note that C1 is across the video detector. It is also possible for *both* picture and sound to be lost.

C2 and L1 form a series-resonant circuit. If the value of C2 (a fixed capacitor) is too small or too large, it may not be pos-

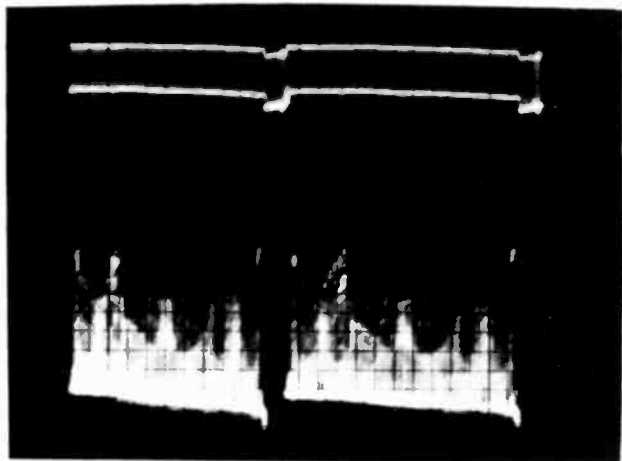

Fig. 309. Sync-pulse compression is indicated by the reduced separation between sync-pulse peak and blanking pedestal in upper half of waveform.

sible to rotate the slug of L1 through the 4.5-mc resonance point. The result will be weak sound or possibly complete loss of sound.

Hum bar in picture

From a servicing viewpoint, it is often helpful to consider the video detector as a sort of halfway point between the antenna and the input to the picture tube. As an example, consider a case of hum in the picture. If a single wide bar is shown, we know it to be a case of 60-cycle hum. Place your scope input across the video detector load resistor. If no hum appears in the waveform shown on the screen of the scope, the hum modulation follows the video detector. If hum appears in the waveform, then the fault is not in the video amplifier or picture-tube circuits but is probably due to heater-to-cathode leakage in the rf or video if amplifier tubes.

Trailing whites

Rotate the channel selector to determine if this condition exists

on all channels. Improper setting of the fine-tuning control can produce this trouble. Sometimes a single oscillator slug needs a slight touchup.

If the trouble is on all channels, the cause can exist in the detector circuit. Please examine the partial schematic shown in Fig. 312. R1 is placed across the secondary of the last if transformer to broaden its response. If R1 should open, the effect would be an increase in gain resulting in ringing in the picture.

Fig. 310. Defective video detector loading can cause poor low-frequency response and resulting picture smear.



A change in the values of R2 and R3 can also produce this condition. As a quick check, make sure the receiver is turned off and then run an ohmmeter check from the cathode of the video detector to ground. The resistance you read will be that of R2 plus R3. The total resistance will be less than 2,000 ohms as a rule. Although R1 has a much higher resistance than R2 and R3 combined, it is shunted by the very low resistance of the secondary of the if transformer. (The resistance check can be made directly from the socket or more conveniently by using a socket adapter.)

No picture, no sound, raster is ok

In those receivers in which the output of the video detector is the takeoff point for both sound and picture, the video detector diode load resistor would represent a good starting point for servicing checks. There will be complete loss of picture and sound; for example, if the video detector is defective. Try replacing the video detector tube.

In some receivers the sound is permitted to go through the video amplifier. In a case of this sort it would be well to examine the circuit diagram to determine a logical first step.

If the sound takeoff is at the plate of the video amplifier, check across the video detector diode load with a scope or vtvm. If this

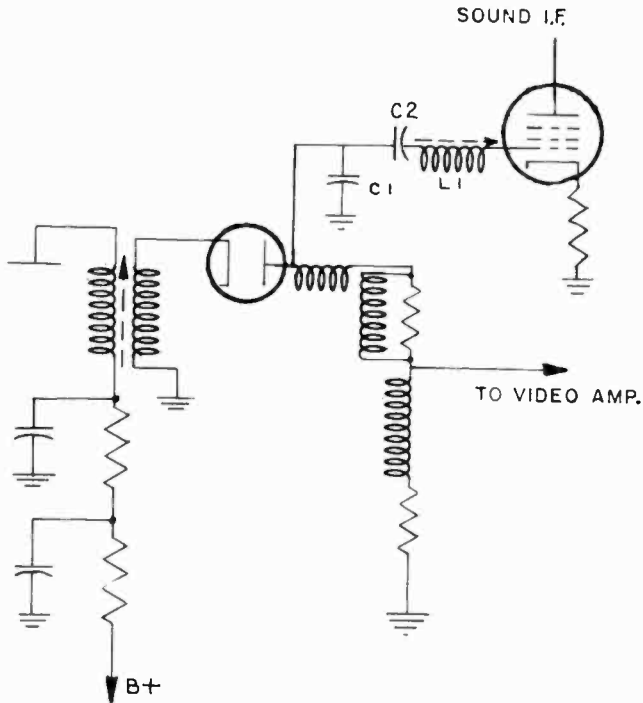

Fig. 311. Typical circuit showing sound takeoff at video detector plate.

check shows the presence of signal, then the difficulty lies between the load resistor and the video amplifier output. A good starting point is to check the video amplifier tube.

If, however, the sound takeoff is at the plate of the video detector, changing the video amplifier tube would be a useless step. In a circuit of this type, suspicion would be directed at the video detector.

The important item to note here is that servicing is dictated by circuit considerations (Fig. 313). In one case the video detector is the starting point of troubleshooting and in the other, the video amplifier. Yet the symptoms are the same for both cases.

Without a circuit diagram, start at the control grid of the sound if and trace back to the takeoff point. Incidentally, some technicians believe (incorrectly) that a double-tuned transformer is always used at the video amplifier output while a series circuit with a single-tuned winding indicates that the output is from the video detector. In some cases the sound takeoff is through nothing more elaborate than a capacitor.

Unusual circuitry

For the most part, video detector circuits are quite simple. Unlike other circuits, the video detector is very often an independent circuit and is ordinarily a self-contained unit. Its independence is particularly emphasized when the detector is a crystal unit. However, you will on occasion run across video detector

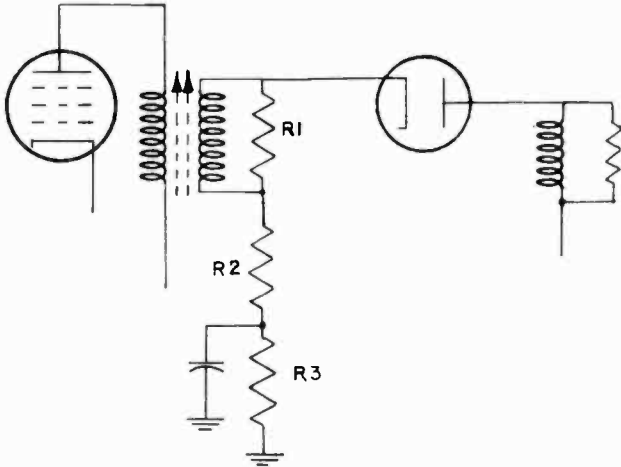

Fig. 312. Changes from the original values of R_1 , R_2 or R_3 may cause trailing reversals in the picture.

circuits that are somewhat unusual and which are affected by the operation of other circuits as shown in Fig. 314.

In examining this circuit, we see that R_2 is in the cathode circuit of the video amplifier. Current flowing through this resistor makes the top end of R_2 positive with respect to ground. This positive voltage is applied to the cathode and control grid of the video detector, connected to that element through the peaking coils and load resistor. The video signal is taken from the *control grid* of the triode. The control grid of the tube is being used as a diode plate. Agc voltage is taken from the plate of the triode. Note that although the cathode and the grid are at the same potential, the cathode of the triode is positive with respect to its plate, resulting in delayed agc action.

The positive voltage placed on the cathode and control grid of the triode will depend in part on the setting of the contrast control but, since both cathode and control grid become more or less positive simultaneously, there is no effect on detector action.

In a circuit arrangement of this type, the presence of a positive

voltage on the cathode of the video detector tube, but not on the control grid, would drive the video detector into cutoff, resulting in complete loss of picture and sound.

Printed circuits

The video detector (as well as other circuits) can be in printed-circuit arrangements. Printed circuits can be used in many differ-

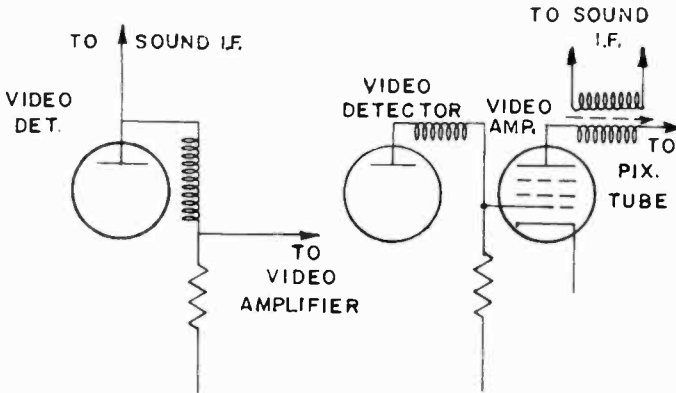

Fig. 313. Sound takeoff may be from the video detector or amplifier.

ent parts of the receiver. Their problems are covered separately in the last chapter (miscellaneous troubles).

Gimmicks

A gimmick is a capacitor. Unlike the familiar fixed capacitor, a gimmick consists of a pair of wires closely intertwined. Capacitance exists because we have two metal conductors separated by a dielectric (in this case, insulation and air). The capacitance of a gimmick is very small, generally less than $10\ \mu\text{f}$. Some receivers use a gimmick as the if bypass in the output of a video detector. If the wires of the gimmick should come undone, it is possible that the presence of the if voltage on the control grid of the video amplifier might cause that tube to be overloaded. The two wires of the gimmick are not supposed to be soldered together. To do so will quite possibly kill both picture and sound. You can always replace a gimmick with a small fixed capacitor of about $10\ \mu\text{f}$. Clip the ends of the gimmick wires and connect them to the capacitor leads.

Crystal detector circuitry

Some technicians confuse the circuitry of a vacuum-tube diode with that of a crystal diode. The reason for this lies in the fact

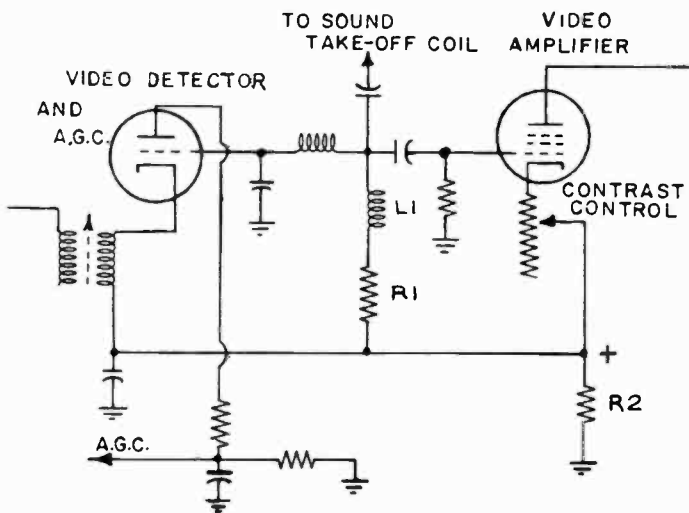

Fig. 314. Plate is age rectifier, and triode grid is used for video detector plate to reduce circuit loading.

that the plate of a vacuum-tube diode is often represented by a straight line. In a crystal, however, the straight line represents the cathode. The arrowhead part of the crystal represents the plate. And current through a crystal flows exactly as it does in a

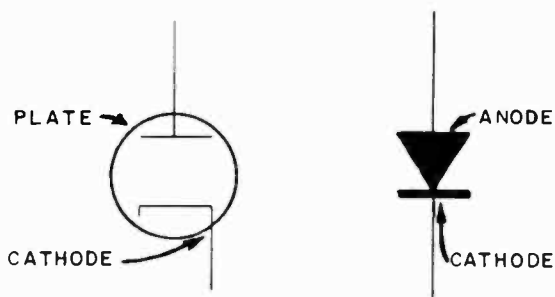

Fig. 315. Tube and crystal diode symbols. Straight line used for tube plate and crystal cathode sometimes causes confusion.

vacuum tube diode — from cathode to plate. This is shown in Fig. 315. (Although this was mentioned briefly earlier in this chapter, we are emphasizing it at this time since the error is such a common one.)

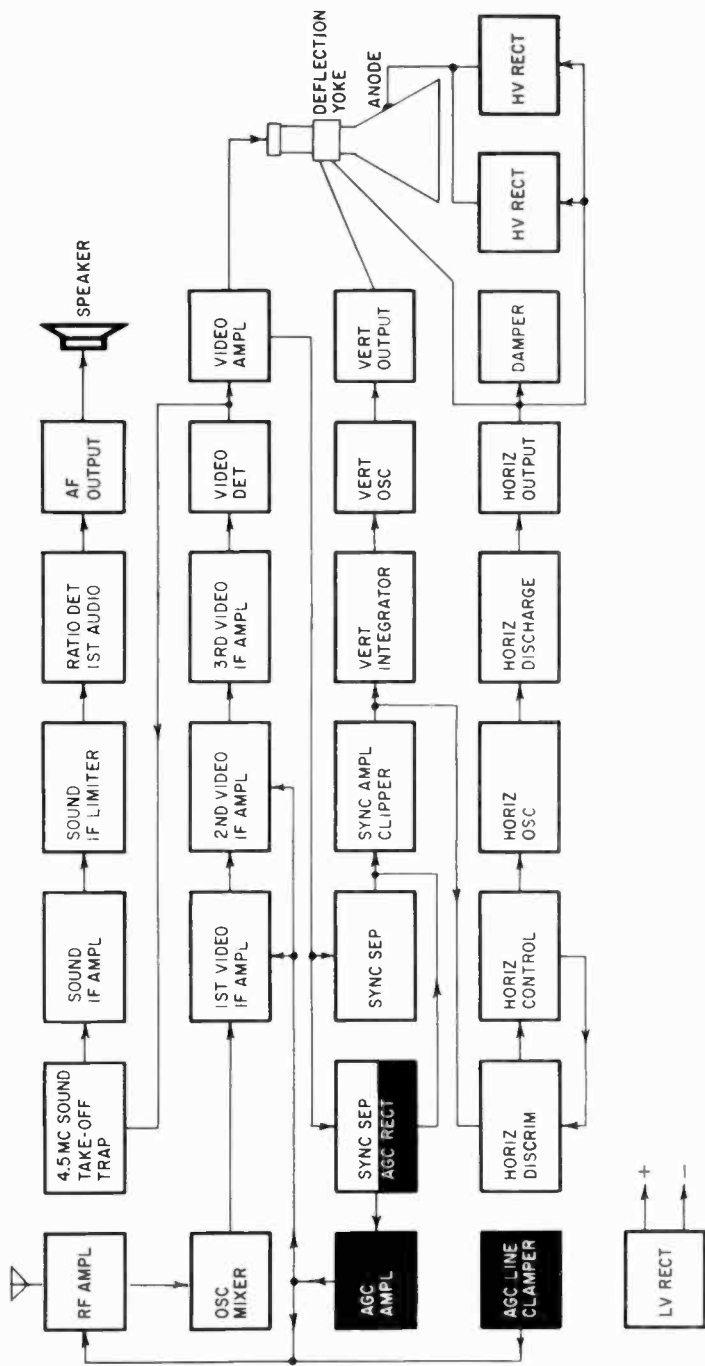

Fig. 401. The automatic gain control circuit is responsible for a number of TV troubles.



automatic gain control chapter 4

If each and every stage in a television receiver were completely independent, the job of servicing would be much simpler. The dependence of TV circuits on each other is not due to any attempt on the part of manufacturers to reduce costs or to compel single circuits to do many jobs. In the case of automatic gain control, it is absolutely essential to have one circuit (agc) control the behavior of other circuits (rf and video if amplifiers). The problem seems to be further complicated by the fact that a defect in agc can produce results or symptoms that are completely opposite to each other. For example, an agc fault can result in a picture that is too weak or too strong. For this reason, do not jump to conclusions. TV symptoms can be very misleading — and time-consuming. The investment of a small amount of time in studying can save you a large number of hours lost on a TV set.

Automatic gain control (agc) corresponds to automatic volume control (avc) in radio receivers. The agc circuit in a television receiver reduces the gain of rf and if amplifier tubes for strong signals and permits these same tubes to work with increased gain when weak stations are being received. Agc permits the television viewer to switch channels without having to make large readjustments in contrast.

The block diagram of Fig. 401 shows the relationship of the agc system to the rest of the receiver. The section we will study

in this chapter has been drawn in reverse blocks. Keep in mind though, that the arrangement shown in Fig. 401 can be modified. Many receivers, particularly older models, make use of a much simpler form of agc.

Agc in a television receiver is a dc voltage. This voltage is applied to the rf amplifier in the tuner and to the video if stages as additional bias. When the incoming signal is strong, the agc voltage increases. The tubes to which the voltage is applied receive it in the form of an increased bias, the control grids of these tubes are made more negative, the current flowing through these tubes

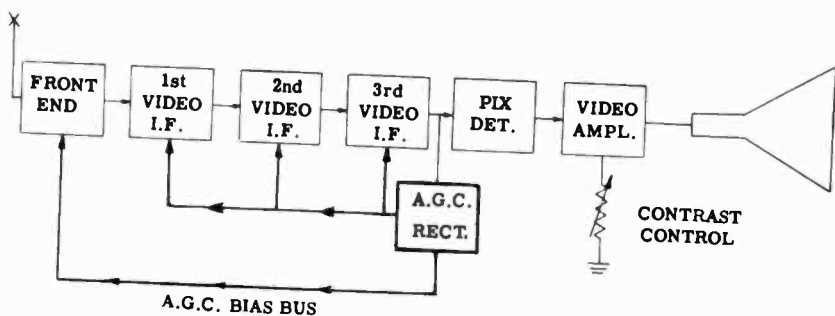

Fig. 402. Block diagram shows agc voltage distribution.

is decreased, and as a result tube gain is reduced. Conversely, if the incoming signal is weak, the agc voltage is lowered and more current is permitted to flow through the agc controlled tubes, and their gain increases.

The basic idea of agc is quite easy. In Fig. 402 is a block diagram showing the path of the signal from the front end to the picture tube. Note that the agc controls the gain of the front end and the video if amplifier. The contrast control takes care of the video amplifier. Thus we have automatic control of the gain up to the video detector, and manual control of the signal after that point. The signal is controlled either automatically or by hand — all the way along its path.

A simple agc circuit is shown in Fig. 403. A diode is used as the agc rectifier. The incoming signal is ac across the secondary of the last if transformer. The negative part of the signal puts the video detector to work, while the positive portion of the

signal is applied to the agc rectifier tube through C1. When a positive signal voltage is applied to the plate of the agc diode, current will flow from the cathode to the plate, down through R2 and ultimately back to the cathode of the agc rectifier. The flow of current through R2 makes the top end of the resistor negative and the bottom positive. The strength of the voltage developed across that resistor depends on the amount of current flowing through the agc rectifier.

The cathode of the agc diode is connected to the cathode of the third video if amplifier tube. The cathode of the if amplifier tube is positive with respect to ground. This positive voltage is applied to the cathode of the agc diode. As a result, the diode cannot conduct until the signal voltage applied to its plate is more positive than the voltage applied to the cathode.

A weak signal will not produce enough voltage to cause the agc diode to conduct. The gain is maximum for weak signals. Only if the signal is strong will an agc voltage be developed to cut down on the gain of the rf and if amplifiers.

A defect in the third video if amplifier tube can affect the agc rectifier and through that circuit affect the front end and the if amplifier tubes. If the current through the third video if amplifier tube should increase, the voltage at its cathode will increase and so will the positive voltage at the cathode of the agc rectifier. As a result, the agc rectifier might be inoperative for moderately strong signals and the result would be overloading of the if amplifier — most probably the third video if amplifier tube.

Types of agc

There are a variety of agc circuits. These include keyed agc, agc clamp, rectified agc, delayed agc, amplified agc, and more. The negative voltage for the agc bus may come from the video detector or from a diode used especially for this purpose. In some receivers, the agc bus is a single line feeding both the rf and the if amplifier tubes. In other sets two separate agc buses will be used, one for the rf amplifier tube in the front end and the other agc bus for the if amplifier.

In servicing a television receiver, do not assume that just one agc bus is present. Fig. 403 shows a typical circuit with a single bus supplying both the front end and the if amplifier tubes. Later in this chapter there is a double agc bus circuit with one going to the rf amplifier in the front end and the other bus to the if amplifier tubes.

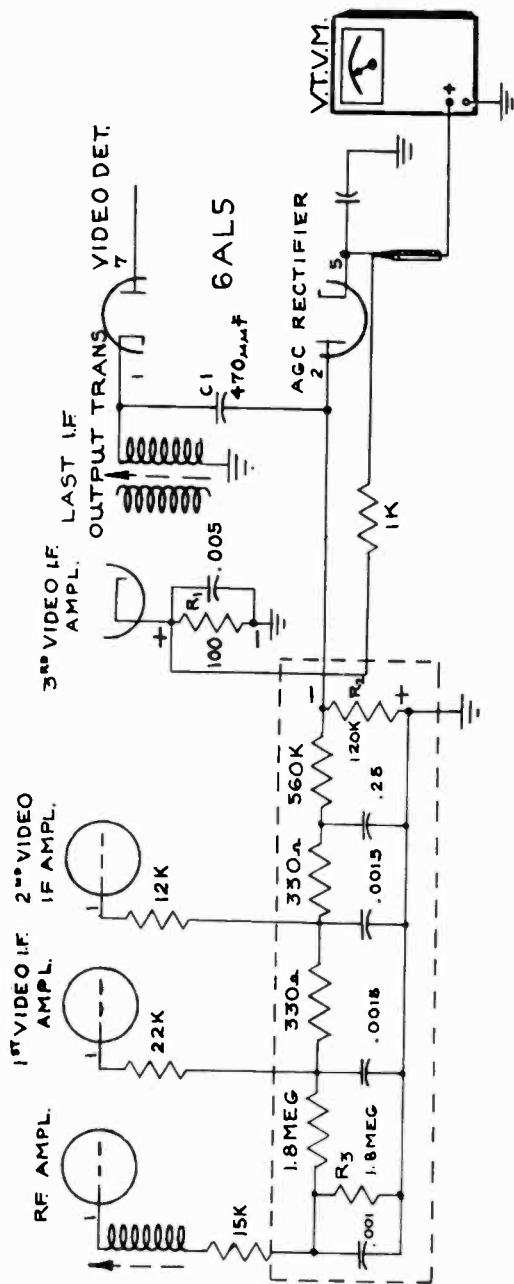

Fig. 403. *V_{tvm}* is used to measure agc delay at the rectifier cathode. Agc bias voltage should be read across R2 as well as R3.

Separate agc diode

It is entirely possible for a single diode to be used both as the video detector and as the agc rectifier. However, with very weak signals there is no need for agc voltage. Actually, unless the video signal can develop at least 1 volt peak to peak across the video detector diode load resistor, agc should not be applied. Delayed agc systems were developed to prevent the application of agc voltage unless the signal came through with sufficient strength. A delayed agc system requires the use of a separate diode.

A common method of delaying agc is to bias the agc detector as shown in Fig. 403. The voltage on the cathode of this diode is

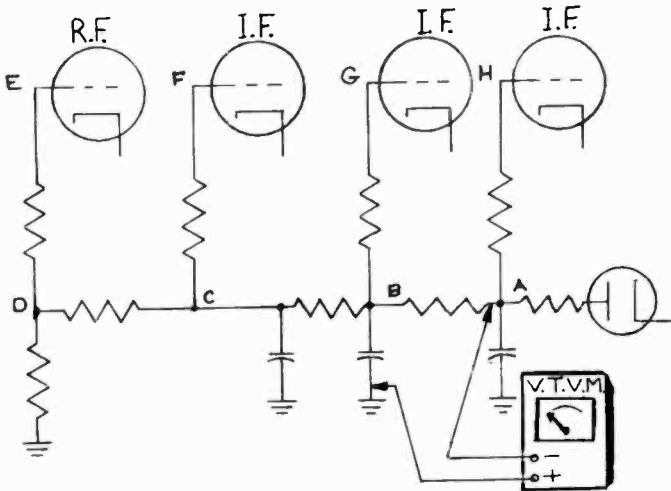

Fig. 404. Leaky or shorted agc bypass capacitors will show zero or lower than normal voltage at A, B, C or D. Gassy or grid-emitting tubes will show less than normal bias (or even positive) voltages at E, F, G or H.

about 2 volts. The diode will not conduct until the signal voltage on its plate is more than 2 volts. As a consequence, agc voltage will not be developed for weak signals, and the rf and if amplifier tubes will be allowed to operate at full gain.

In a system of this sort, any trouble which causes the diode to lose its bias voltage or causes the diode to operate with lower than normal bias can mean loss of picture and sound (due to excessive agc bias on the controlled tubes) or any of the other troubles that have been discussed in this chapter.

The bias voltage on the cathode of the agc diode is dc, and can be measured with a vacuum-tube voltmeter as shown in Fig. 403.

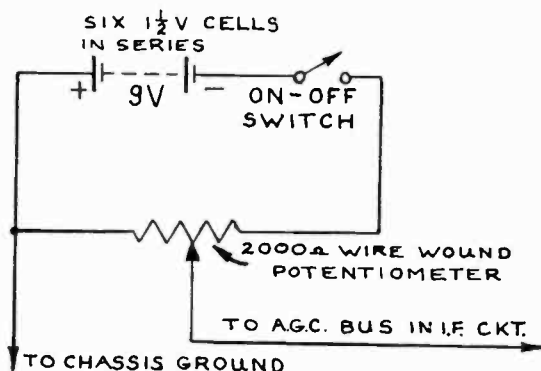

Fig. 405. Battery box for agc substitution has a variable output voltage.

Note: Do not use a low impedance volt-ohm-milliammeter (vom) in measuring agc bias voltages. Always use a high-impedance voltmeter. The vom may load the agc bus and produce a reading that will seem far below normal.

The agc rectifier and the filter network following it are very similar to the half-wave rectifier and filter used in the power supply in ac-dc receivers. There are only two differences: The agc filter uses more resistors and capacitors, and these filter components have values that are different than those found in power supplies.

Check an agc supply just as you would a power supply. Start at the most negative point (plate of the agc rectifier) and work your way forward through the filter, step by step. Fig. 404 shows how this is done. The vtm range control should be set to read a maximum of about minus 10 volts dc. Probe points A, B, C, etc. as shown in Fig. 404. If a test at point A, for example, shows the presence of agc voltage but point B does not, then obviously the resistor between A and B is open, or capacitor at B is shorted.

Threshold control

Earlier TV sets using the simple agc system shown in Fig. 403 have no means of varying the agc bias level. In later sets, however, a potentiometer is used so the agc bias voltage can be modified for varying signal conditions. This agc control has a variety of names and is known as the threshold control, fringe compensator control, picture stabilizer, dx range finder, electronic stabilizer, fringe-local switch, local-distance switch, etc. Misadjustment of this control can result in a picture with snow; a weak, washed-out

picture; excessive contrast that cannot be reduced by any setting of the contrast control; vertical bending; picture smear, or excessive buzz that cannot be eliminated by any setting of the fine-tuning control.

The easiest check and quite possibly the best check is to tune in on the test pattern of a station. Select that channel having the strongest signal. Adjust the agc control until the pattern becomes strong, and keep turning the control until you begin to notice the first signs of an overloaded picture. You will observe a point at which the contrast definitely becomes excessive. This may be accompanied by bending of the vertical lines. There should be no break or jump in the rotation of the potentiometer. If there is, turn the receiver off, and connect an ohmmeter between the center terminals and either one of the outer terminals of the pot. Rotate the control and watch the ohmmeter. The needle movement should be very smooth. If not, clean or replace the pot.

After you have found the best setting for the threshold control, tune in other channels and note the effect the control setting has on them. If you originally selected the strongest channel for this test, then you should have no overloading on any channel.

Dc bias supply

Somewhat earlier we learned that the agc voltage is dc. There can really be only two troubles with this dc voltage — it can either be too much or too little.

One way of determining if the agc voltage for a particular receiver is correct is to shunt the agc bus with a dc voltage. The voltage that you use can range anywhere from 1.5 to about 9. Using the circuit diagram of the receiver, locate the resistor across which the agc voltage is developed and shunt the battery voltage across it. Watch polarity. The plus side of the battery connects to the chassis and the minus side of the battery to the minus side of the resistor. Fig. 405 shows how batteries can be used with a variable resistor to supply any voltage up to 9.

Use the agc test points of the receiver. Some sets do not have these test points, others have just one test point, while in some sets you will find a test point for the if amplifier and another one for the rf amplifier. If the receiver has such a test point (or points), connect the minus side of the battery to the test point and the plus side to the chassis.

Batteries will lose their voltage whether you use them or not. Use a commercial bias supply (or build one) similar to the type

shown in Fig. 406. The minus lead of the supply goes to the test point, the plus side to the chassis. Connect a dc voltmeter (preferably a vtvm) across the output of the supply, as shown, so that

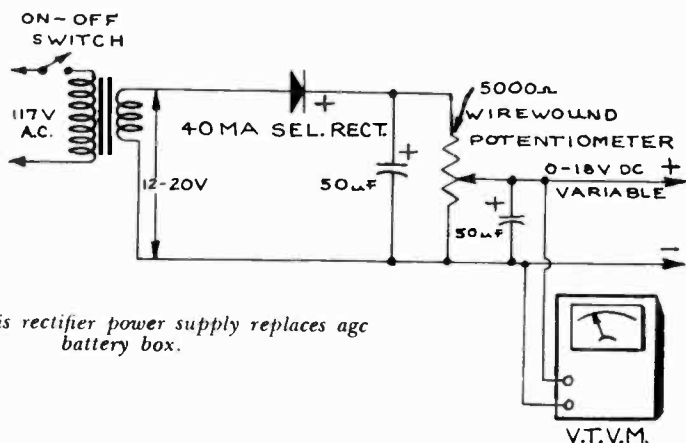

Fig. 406. This rectifier power supply replaces agc battery box.

you can obtain some idea of the voltage you are using. It will not be necessary to disconnect any portion of the agc bus.

Tune in on a channel, preferably the channel that seems troublesome. Slowly rotate the potentiometer of the bias supply. If the picture does get better, it is very probable that there is some trouble in the agc system. *Caution:* In some receivers the plus return of the agc system is to B-minus of the receiver and not to the chassis. This is usually the case in transformerless receivers.

Alignment and agc

Since it is the function of agc to help the receiver maintain a constant output signal, we can see that the agc system will fight any attempt at realignment of the receiver. If you use a strong signal out of the sweep generator, the agc network will develop a stronger bias, reducing the gain of the tubes through which the signal will pass.

Some technicians feel that by disabling the agc, alignment will not be hindered. However, by so doing you will have a condition under which the tubes will work with maximum gain—and this is definitely not the way in which the tubes will work in practice.

When realigning use a battery (Fig. 405) or an ac powered bias supply (Fig. 406) connected from the agc test point (or test points) to ground. Manufacturers supply information on the

amount of bias voltage to use but this is an average for all receivers in all areas. For a fringe area you will need less agc voltage than in a strong-signal area. The correct amount of fixed bias voltage to use during realignment is that amount of bias which would be developed by a signal in your particular area. This is why agc voltage measurements are so helpful. By making such measurements — and keeping a record of them — you will soon learn just what agc bias voltages you can logically expect to find. This information will not only help you realign properly but it will also enable you, with one simple voltage test, to determine if the agc system is functioning properly.

Keyed agc

There are several difficulties involved in the simple agc system shown in Fig. 403. Noise pulses (and these usually have fairly high amplitudes) can come through the front end and if stages of the TV receiver, become rectified by the agc diode and be fed back to the controlled tubes as a rather high bias. As a result, the gain of the receiver might very well be made the weakest — even though the signal itself at the particular moment might be very weak.

Another problem connected with the agc circuit of Fig. 403 is that its time constant is too long. This is just another way of saying that the circuit simply doesn't respond rapidly enough. For example, some signal variations take place so rapidly that they are detected, strengthened by the video amplifier and passed on to the picture tube (and shown on the screen) before the agc circuit has had an opportunity to change its agc bias strength. One serious consequence of this is a trouble known as *airplane flutter*. TV signals are reflected from the metal surfaces of the plane and reach the television antenna in very rapid sequence. The result is a picture that bobs up and down. A fast-acting agc system would rapidly vary the bias on the rf and if tubes so that the result would be a uniform signal output from the video detector.

Keyed agc was developed for a faster-acting system. A typical keyed agc circuit is shown in Fig. 407. Note, first, that the control grid of the agc keyer (or agc amplifier) is fed the amplified composite video signal. The plate gets its voltage from a width coil connected to the flyback transformer. This means that the plate receives a pulse voltage. This pulse voltage is derived from the horizontal sync pulses. The keyer tube conducts only when the sync pulses hit the plate of the keyer tube. Most of the composite

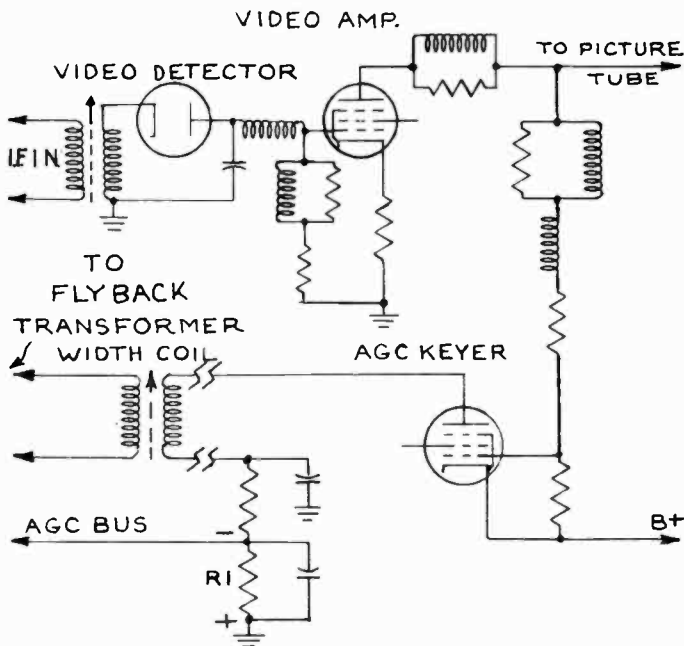

Fig. 407. Keyed agc circuit gets its plate voltage from a pulse supplied by the horizontal amplifier.

video signal applied to the control grid is ineffective. However, the horizontal sync pulses reach the control grid at the same time that the plate is pulsed.

Sync pulses are always transmitted at a constant level. A received signal that is strong will have sync pulses of higher amplitude than those of a weak signal. But the important point to remember is that the sync pulses of a particular station are all of the same amplitude.

Since the sync pulses are of constant strength, they can be used to fix the agc bias voltage at a desired level. Weak sync pulses fed to the control grid of the keyer tube will mean a small current flow through that tube, hence a smaller agc voltage with greater gain in the rf and if tubes. Conversely, a stronger signal has sync pulses of higher amplitude, resulting in a high agc bias.

Follow this action and see the sort of repair troubles this circuit arrangement can bring. Assume that a signal is coming through and that the composite video signal is reaching the control grid of the agc keyer. The tube will not conduct until a pulse reaches

the plate of the keyer from the width coil. At that moment, the control grid of the agc keyer will be receiving the sync pulse of the composite video signal. Current will flow from the cathode of the keyer, through the width coil and through resistor R1 to ground. The flow of current through R1 makes the top end of that resistor negative and the bottom end positive. The agc bus is connected to the top end of R1. A strong signal will cause more current to flow through the resistor, hence more agc bias. A weak signal means less current flow and less bias.

Keyer tube failure

If the keyer tube becomes completely defective or simply weak, the agc bias drops to a lower than normal value or may disappear entirely. The result is that the rf and video if amplifier tubes operate wide open and cause overloading.

Under conditions of agc keyer tube failure, the strength of the signal cannot be controlled by the contrast control. The overload takes place in tubes not governed by the contrast control. The overload, which is really amplitude distortion due to improper operation of the rf and video if tubes, is not changed by any adjustment of the contrast control.

Excessive bias

If for some reason the B-plus on the cathode of the keyer should decrease, the resultant increase in current flow will mean excessive agc bias. This can result in snow, a very weak picture, poor horizontal and vertical hold.

In this agc circuit, as in any other, there are two general troubles. Either the agc voltage is insufficient or it is too high. If the receiver has an agc test point, connect your vtvm probes between the test point and the chassis. If possible, tune in a station and note the amount of agc voltage. Substitute a new agc keyer tube and note its effect on the agc bias. If no change is noted the trouble is elsewhere in the circuit. Measure the dc voltage on the cathode of the keyer tube and then measure the dc voltage on the plate of the video amplifier tube. The voltage on the cathode of the keyer tube should definitely be lower than that on the plate of the video amplifier tube. If the voltage is the same, the video amplifier tube is not conducting. In this case there is no picture on the screen. The effect also removes the bias on the agc keyer. A heavier than normal current flows through the keyer tube, resulting in a strong agc bias. Probably the first conclusion

gain. However, it is possible for the video if amplifier tubes to become overloaded. These should receive some agc voltage.

Consider the opposite condition in which the incoming signal is very strong. We then want the agc bias applied to the rf amplifier tube to be stronger than the bias for the video if tubes.

A method for controlling the bias that meets these varying conditions is shown in Fig. 408. Resistors R1 and R2 form a voltage divider so that only about one-third of the agc voltage goes to the video if tubes.

Now examine that part of the circuit consisting of R3, R4 and V1. They are connected to the bus that goes to the control grid of the rf amplifier tube in the front end. V1 is a diode and is known as a clamp tube, clamping diode or agc line clamper. Note that resistor R4 (usually more than 5 megohms) is the plate load for V1. Resistors R3 and R4 form a voltage divider for the agc voltage for the front end. Resistor R3 has a very small value compared to R4. This means that practically all the agc bias voltage is developed across R4 and is applied to the bus going to the front end. However, V1 shunts R4. If V1 should conduct, it shorts R4 and no agc bias voltage is fed to the front end.

With no signal coming in, no agc voltage is developed and V1 conducts. If a weak signal should arrive, it is applied to the plate of V1 as a negative voltage, reducing the B-plus voltage on the plate of V1 by that amount. When the negative agc voltage is high (as with a strong signal), it is equal to the plate voltage on V1. But, since the agc voltage is negative and the plate voltage of V1 is positive, the net effect is to reduce the voltage on the plate of V1 to zero, and the tube does not conduct. In other words, V1 conducts for weak signals, removing agc bias on the rf amplifier and permitting that tube to work at maximum gain. For strong signals, V1 does not conduct and the full agc bias voltage is placed on the control grid of the rf amplifier.

Clamp circuit troubles

If the clamp tube should become open-circuited (or if the tube is removed), the full agc bias voltage (for all signals, weak and strong) is applied to the rf amplifier tube. This means that all signals are considerably reduced in strength. The result is a weak, washed-out picture with possibility of critical sync action.

If the clamp tube should become short-circuited, there would be no agc voltage for the rf amplifier tube, with overloading, negative pictures, rolling and tearing of the pix. There is the possi-

bility that, with a loss of agc bias, the rf amplifier tube might burn out, especially if the agc is its only source of bias.

If R4 should become shorted or greatly reduced in value, B-plus voltage is applied to the control grids of the rf amplifier and the video if tubes. The same symptoms of overloading and rolling, tearing and negative pictures would be evident.

Although the clamp tube is a diode, it may be a part of some other tube (multipurpose tube).

Representative agc defects

A defect in the agc system can cause a large variety of symptoms, many of which can be confused with troubles in other circuits. We can list these troubles as follows:

1. Loss of picture and sound; loss of picture alone; (overloading).
2. Over-contrasty picture. Strong blacks which cannot be reduced.
3. Unstable picture.
4. Washed-out, weak-looking picture. Very poor contrast.
5. Snow in picture.
6. Vertical line bending in picture.
7. Smear.
8. Picture contrast keeps changing while picture is being watched.
9. Rolling. Horizontal sync is critical.
10. Excessive noise. (This may be due to a design fault. Simple agc systems are more subject to noise than keyed agc systems.)
11. Picture flutter. (This may be due to a design fault. Simple agc systems may not be fast acting — that is, their time constant is too long.)
12. Buzz.
13. A 60 cycle hum bar in picture. This appears as a single wide bar across the screen.
14. Negative picture.

Because this rather long list can cause a considerable loss of time make a quick check on the agc system: (a) Rotate the channel selector to some other channel to see if the symptoms disappear. (b) Adjust the agc control and note its effect on the symptoms. (c) Measure the agc voltage to see if it is normal for the particular channel. (d) Use a substitute voltage from a battery or bias supply.

If the use of any one or all of these techniques minimizes or reduces the symptoms, look for trouble in the agc system.

Overloading

Service technicians realize that tubes must operate with proper plate and screen grid voltages. Less well known is the fact that every tube requires its proper bias and input signal voltages. If the input signal is too large the tube — whether rf, if or video amplifier — can become overloaded. The amount of signal that can be fed into a tube depends on the amount of bias on that



Variable bias supplies are manufactured to make to application of specified agc voltages simple for servicing and alignment. (Precision Apparatus Co. Inc.)

tube so these two voltages — input signal and bias — are dependent on each other.

Overloading has a variety of symptoms, based entirely on whether the overload is slight or severe. If the overload condition is very strong, it can drive the picture tube into the cutoff region, resulting not only in a loss of the picture but the raster as well. Normally the raster will be restored with an increase of the brightness control setting.

A moderate amount of overload can produce a negative picture as shown in Fig. 409. This may be accompanied by loss of sync (rolling and tearing). Here again symptoms might be caused by other circuits. Loss of sync might be due to a defective sync separator and a negative picture could be caused by a crystal detector wired in with reversed polarity.

If the overload is not severe, it can distort the picture by causing picture hook and excessive contrast. Generally, this condition can

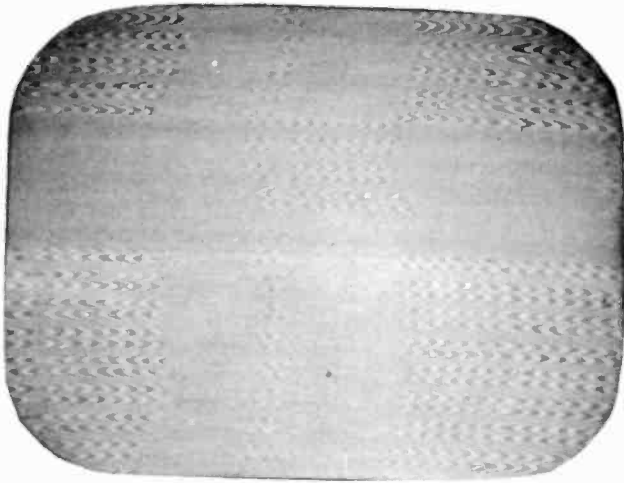

Fig. 409. *A negative picture may be produced by overloading signal conditions.*

be relieved by adjusting the contrast control. In practically all sets, it is easy to cause overloading by advancing the contrast control far enough. However, the signal should not be so strong that the contrast control must be set close to its extreme counter-clockwise position. Excessive signal strength tends to make the setting of the contrast control somewhat critical.

Overload can produce symptoms which resemble those caused by defects in other parts of the receiver. We are naturally interested in isolating the trouble. Adjust the agc control (if loss of raster is due to a high-voltage defect, no possible setting of the agc control will restore it). If loss of picture is caused by a severe overload, resetting the agc control should relieve the condition.

There are other tests to try. With a raster on an off-channel setting of the selector switch, but it disappears when the selector is set on the channel, overload is indicated. Another way of checking is to disconnect the transmission line leads, but hold them close to the antenna terminals. If the condition—loss of raster, picture hook, negative picture—is improved, the cause is definitely agc trouble.

Overload may be caused by conditions outside the receiver. A new antenna having higher gain can do it (the substitution of a conical antenna having reflectors in place of a simple dipole can produce this trouble). The customer may have moved from

a fringe to a strong-signal area. The television station may have increased its power or moved to a new location or put in a more efficient antenna system, etc. Thus there are many reasons why a television receiver that has been working well suddenly develops the symptoms we have described. Always remember that you, as well as other technicians, are bothered by the screwdriver-happy customer who tampers with the service controls.

Excessive snow; poor picture contrast; washed-out picture

These symptoms indicate that the agc bias is excessive as shown in Fig. 410.

Connect a vtvm to the agc test point and rotate the agc control.

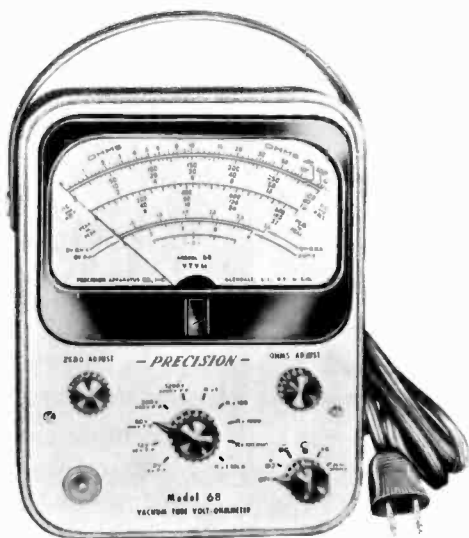

It is difficult to measure many of the circuit voltages without a vtvm. The constant impedance of these meters for all voltage ranges is specified by manufacturers for testing. (Precision Apparatus Co. Inc.)

If turning this control produces no deflection on the meter and if the agc bias still remains high, take steps to reduce the agc voltage. Connect a 5,000-ohm potentiometer so the center arm goes to the test point and one outside terminal (either one) is attached to the chassis. Vary the potentiometer until the agc bias is normal or typical for your particular area. The reduced voltage obtained in this way should bring the picture back to normal. If it does, then the fault definitely lies in the agc circuit. If not, then the trouble is outside the agc system.

With a condition of excessive snow, the trouble most often lies in the front end. Check the agc bus from its start to the control grid of the rf amplifier tube. Poor picture contrast is probably

due to excessive agc voltage going to one of the controlled video if amplifier tubes.

Critical horizontal hold

Sometimes the horizontal hold control is very touchy and a slight misadjustment causes the picture to tear. At times, the vibration of someone walking across the floor to the receiver forces

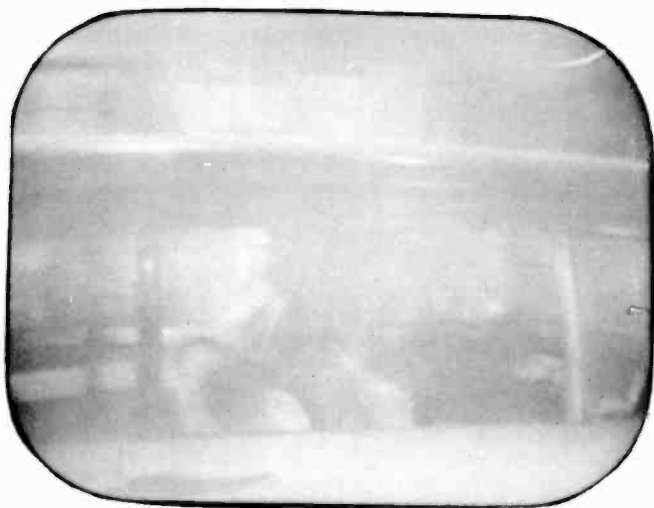

Fig. 410. Excessive agc bias voltage can produce a weak, washed-out picture.

the picture to go out of sync. A logical conclusion to reach is that the difficulty lies in the horizontal afc circuit, and yet critical horizontal hold can be the result of some defect in agc. Trouble due to a border-line component value in the afc circuit may be aggravated by incorrect agc bias.

To determine quickly where the trouble exists, connect a fixed voltage to the agc bus. If this improves the ability of the set to remain in horizontal hold and the positioning of the horizontal hold becomes less critical, some defect exists in the agc system. If not, then afc trouble is indicated.

Intermittents

An intermittent can exist in the agc system, causing the picture to range between poor contrast and snow, to normal, to excessive contrast and back again. Here again use the troubleshooting procedures that have been described earlier.

Excessive contrast

This is a condition caused by insufficient agc bias (Fig. 411). In simple agc systems it is possible that one of the agc filter capacitors may be leaky (providing a low-resistance path to ground) or shorted. Check resistors R2 and R3 in Fig. 403 to see if they have decreased in value. In keyed agc systems, a defective keyer tube (low emission) or other defective component which limits current flow through the tube can produce this symptom.

Single, wide black bar across the screen

This is a 60-cycle hum bar and can be due to leakage between the heater and cathode of the agc rectifier, as well as tuner and



Fig. 411. Excessive signal voltage at amplifier inputs may result in too much contrast and picture bending. An extreme condition may result in an almost blank raster.

if tubes. The filter network in the agc system will not reduce this hum voltage for two reasons — the values of filter capacitance in the agc network are very small, and the frequency of the hum voltage is very low. As a quick check, connect a 20 μf capacitor anywhere along the agc bus to ground. Be careful. The chassis is to be considered positive. If using a metal-encased capacitor, the can connects to the agc bus and the positive terminal of the capacitor connects to the chassis. Low-voltage, cathode bypass capacitors are perfectly suitable. If the capacitor minimizes the hum bar

on the screen (it may not eliminate it completely), try substituting a new agc rectifier tube.

Airplane flutter and picture flicker

This is generally symptomatic of older sets not using keyed agc. If the condition is one that did not previously exist in the set, the trouble may be due to a change in the time constant of the filter network of the agc system. The trouble is caused by the increased value of one or more of the R-C components. Check the values of all components in the filter. Make sure they correspond to recommended values indicated in the manufacturer's schematic.

In older receivers using simple agc, airplane flutter is a design problem and is one that is not generally considered a servicing job.

No contrast

Oddly enough, there are two extreme conditions which can produce this symptom. If the agc bias is very high (above normal), the gain of the rf and video if tubes may be reduced to the point where the signal comes through in very attenuated form. The contrast control is of no help. In cases of this kind, you will find the contrast control often set close to the extreme clockwise position.

If the agc bias is very weak (below normal), the signal will be so strong that the picture will be excessively dark and proper contrast will not be obtainable. Adjusting the contrast control to a minimum position will not help.

Loss of contrast can be caused by any defective component — tube or part — which increases or decreases the agc normal bias level.

Agc voltage is zero

Substitute a new agc rectifier tube or keyer tube. Resistance-check through the agc filter to determine if you have any shorted components.

Agc voltage is too high

Any factor that causes an increase in current flow through the agc rectifier or the agc keyer tube raises the agc voltage. The tube may be gassy. Check to make sure that the keyer tube has the proper operating bias. Look for changed values in the agc filter (resistors and capacitors).

If the receiver uses an agc control check to make sure the customer has not tampered with it. Vary the pot to see the effect this control has on the agc voltage.

The agc system is very much like a power supply having a variable dc output. Consider the agc voltage in a receiver just as you would any other voltage — and just as important. Actually, agc voltages are more important than plate voltages. A small decrease in plate or screen voltage may not affect the operation of the receiver noticeably, while a small decrease or increase in agc voltage can produce a variety of symptoms.

Multipurpose tubes

Since the agc rectifier is a diode, it is often associated with multipurpose tubes. This can sometimes lead to complications. In a tube such as the 6T8, for example, we have a triple diode-triode. This tube has two cathodes. One is common to two diode plates and a triode plate. If the triode section is used as an audio amplifier, removing the tube kills the sound and also removes the agc bias voltage. If the tube develops heater-to-cathode leakage, you may hear hum in the sound and have a single hum bar on the screen. The presence of both symptoms might be misleading since we do not ordinarily associate sound troubles with the picture agc. Inadequate cathode emission (weak tube) might lead to lowered sound but the picture might be over-contrasty (or even overloaded, picture bending, etc.) due to the reduced agc voltage. Here again you would have *pairs* of symptoms not normally associated.

Another multipurpose tube that falls into this category is a duo-diode-triode having a single cathode. A weak tube can cause troubles both in sound and picture if the triode section is used as an audio amplifier.

Sometimes a dual diode is used as video detector and agc rectifier. A typical tube is the 6AL5. Since each diode section has an independent cathode, it is possible for one cathode to lose its emission properties faster than the other. If the picture rectifier (video detector) should become weaker than the agc rectifier, the effect would be the same as that of a weak signal. The agc bias voltage would become lower, and the rf amplifier and video if tubes would operate at higher gain.

Now this might seem perfectly satisfactory since the agc is doing exactly what it is supposed to be doing — permitting rf and if tubes to work at greater gain. However, this represents a poor operating condition. The greater sensitivity of the rf and if tubes means greater opportunity for noise to come through and show on the screen. The greater current through the rf and if tubes can

result in overloading. Quick-check by substituting a new double diode. Take dc voltage measurements across the video detector diode load resistor and also the agc voltage. As a general rule, these two voltages should be approximately equal.

No picture, no sound

Turn the channel selector. If a raster appears on the screen for an unused channel, you can consider the possibility of trouble



Semiconductor diode testing has been simplified by the Diode Transistor tester.

in the agc circuit. Even if the receiver uses keyed agc and depends on pulses from the flyback transformer, a raster would indicate that the high voltage supply is functioning. Complete loss of picture can be due to an improper setting of the agc level control. If pictures come in for weak stations but not for strong ones, agc trouble is indicated.

Agc voltage is zero or positive

Some video if stages are impedance-coupled — that is, they have a tuned primary and are R-C-coupled into the grid of the next video if stage. A leaky coupling capacitor could permit enough B-plus to leak through to overcome the normal agc bias and make the agc bias positive. Since the bias bus connects the control grids of three (or more) tubes together, this single defective component can cause the other agc-controlled tubes to burn out. A similar condition can be produced by a gassy rf or video if amplifier or a short between elements of these tubes. A single defective

tube can, in this way, damage other tubes tied into the agc bus.

Detector and agc

In some receivers using a crystal detector, there is no separate agc rectifier. The output of the crystal detector is fed to the video amplifier and to the agc bus. Deterioration of the crystal in service can lead to any of the agc troubles mentioned earlier. Check the forward-to-back resistance of the crystal diode. The resistance ratio should be 1,000 to 1. If the crystal does not test satisfactorily, replace it. (Refer to Chapter 3, in which crystal diode defects were described.)

R-C values in agc circuits

The number of capacitors and resistors in the agc filter varies widely in value and number from one receiver to the next. Since the filter action is the product of R and C (or $R \times C$), any number of possible combinations would be suitable. Although R-C values

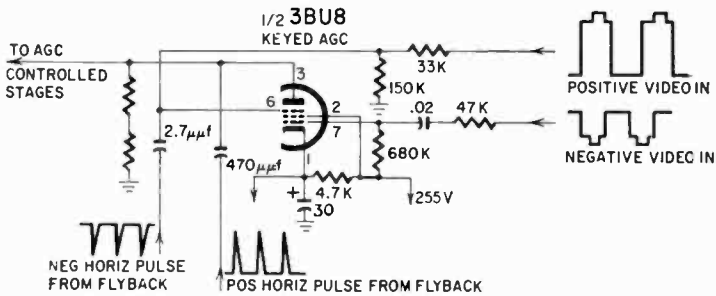

The additional pulses in this circuit are used to stabilize the keyer tube and neutralize the pulses fed through the tube's interelectrode capacitances. This effect is most critical in fringe-area reception.

are not critical, it is generally best to replace resistors and capacitors with equivalent units.

Picture is too strong, then improves

If the receiver must be in operation for a period of time before a good picture is obtained, the trouble can be due to a slow-heating cathode or a cathode with reduced emission in an agc rectifier, agc clamp or in a keyed agc amplifier tube. Check by tube substitution.

60-cycle sync buzz

Sometimes the picture will come through to the picture tube but an annoying buzz will be heard on some channels. This condition can be caused by operating the rf and video if amplifier

tubes on a non-linear portion of their characteristic. If the agc voltage is low, it is easy for the video signal to be too strong at the tube input. This results in non-linear operation of one or more tubes. These tubes now act as combined amplifier-mixers and distortion is produced in the tubes. This cross-modulation results in a buzzing sound that is heard in the speaker. If shunting the correct bias voltage (using batteries or a bias box) across the agc bus reduces or eliminates the buzz, the trouble is definitely in the agc system. Check the various factors that could cause reduced agc — weak agc rectifier tube, improper bias on the agc keyer amplifier tube, etc. Don't neglect the low voltage rectifier.

Odd symptoms

Defects in the agc system can produce some very strange symptoms. Quite often the symptoms are so misleading that they can become very serious time wasters. Consider a condition in which vertical hold is poor but horizontal sync seems reasonably good.

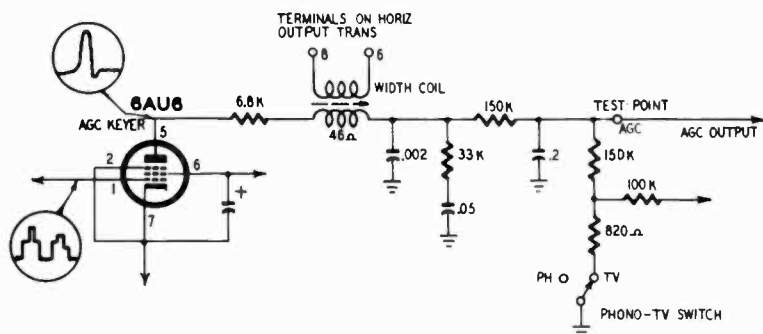

The familiar keyed agc requires pulses from the horizontal amplifier circuit and the blanking pedestal, and sync pulses from the video stage to develop the required agc voltages.

It would be very logical to conclude that the trouble had something to do with vertical sweep. Or a condition in which the sound is very distorted. Here again a first conclusion, and a reasonable one, would be to check through the sound system. And yet symptoms such as these have been found to be caused by a defective agc system. Quick-check by tuning in on a strong channel and try to aggravate the symptoms — that is, make them as definite and as noticeable as possible. Remove the transmission leads from the antenna terminals but hold them close to the board so that there is some capacitive coupling. If the symptoms disappear, the trouble is definitely due to agc defects.

Mechanical difficulties

Some receivers use two- or three-position switches (usually mounted on the rear apron) for making rough adjustments in agc voltage. These switches – usually identified as local-distance, sensitivity control, or fringe-suburban-local or similar names – are adjusted for area conditions. Since these switches are seldom used, they should (theoretically) never become defective but contacts can tarnish or get dirty. As a quick check, tune in on a station and then turn the switch. The effect on the picture should be noticeable.

Manufacturer's changes

In checking a receiver against a circuit diagram, some values of components in the set may not correspond with the diagram, or some parts may be missing or have been rewired. There are sev-

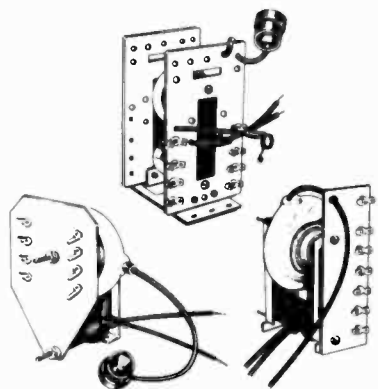

Horizontal output transformers with many terminal connections may have an agc winding included in their manufacture. (Chicago Standard Transformer Corp.)

eral possibilities. Sometimes a manufacturer makes design changes after the receiver has been in production for some time. These changes are usually described in modification sheets released by the manufacturer and often published in technical magazines. The set may have been modified by some other technician during some earlier trouble. If, for some reason, you must make changes, make a note of the modifications and mount the note on the inside of the cabinet.

Intermittent picture contrast

Contrast will sometimes change when a shift is made from camera to camera at the television station. However, if picture contrast fluctuates on all channels, check the agc voltage to see if it is fluctuating. An intermittent in the agc system can cause this trouble.

Dots and streaks in the picture

A receiver may present a problem to the service technician even though it is in apparently good order. Quite often a set is pulled and works well in the shop, only to result in a callback. When this happens, remember that receivers must sometimes be adjusted to work best in a particular location.

In an earlier chapter, we indicated some remedies for this type of trouble. The difficulty may be indirectly due to the agc system. There is no point in having the agc controlled tubes any more sensitive than is necessary. Readjust the agc control so that the agc bias is increased. This will reduce the gain of the con-



Width coils with four or more terminals may have provisions for agc keying voltage takeoff. (Chicago Standard Transformer Corp.)

trolled tubes. While this method reduces signal strength, it also reduces the noise at the same time. Use the suggestions mentioned in Chapter 1 for improving the signal-to-noise ratio.

Jumping picture

In weak-signal areas, noise pulses can produce a jumping picture. The noise is usually man-made interference, such as that produced by automobiles and electrical appliances. Careful adjustment of the agc level control is necessary to minimize or eliminate this condition. Also use the techniques described earlier for improving the signal-to-noise ratio.

Excessive video signal

It is possible to supply so much signal to the picture tube that the picture is completely cut off, leaving a blank screen. Switch to an unused channel. The return of a raster eliminates the need for checking into high-voltage circuits.

If a test across the video detector load resistor reveals abnormally high signal voltage, there is a possibility of regeneration in

the rf and if stages or some defect in agc. A measurement of the agc voltage will quickly determine which of these two possible causes is the real one.

Misadjustment of the agc control can kill sound in addition to the picture. Additional troubles due to an improper setting may be picture smear, excessive contrast, buzz, bending of vertical lines. To discourage customer tampering with this control after it has been set properly, cover the shaft of the control with a small piece of cellophane tape.

Checking keyer voltages

The pulse voltage on the plate of the keyer may run from as little as 300 (or less) to as much as 800 (or possibly more). To check for signal voltage at the control grid or the plate, use an oscilloscope with the horizontal sweep set to 15,750 cycles or one-half of this figure.

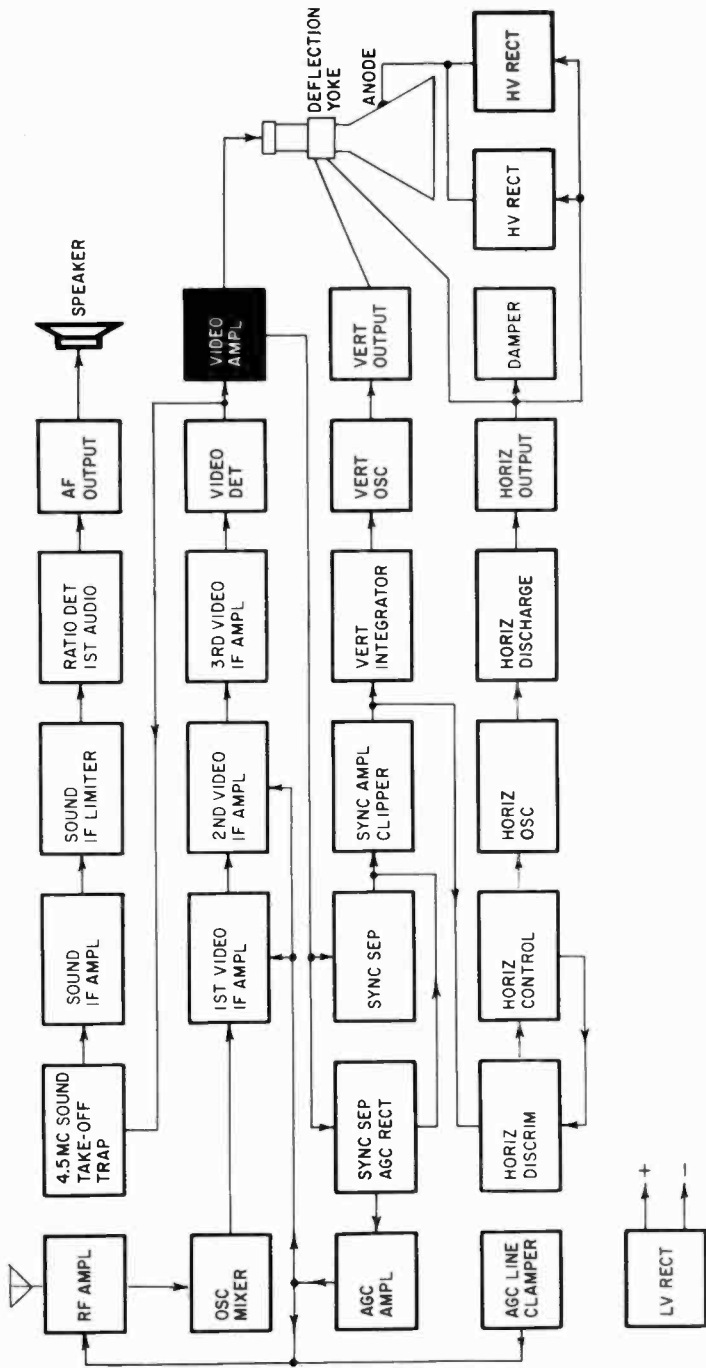
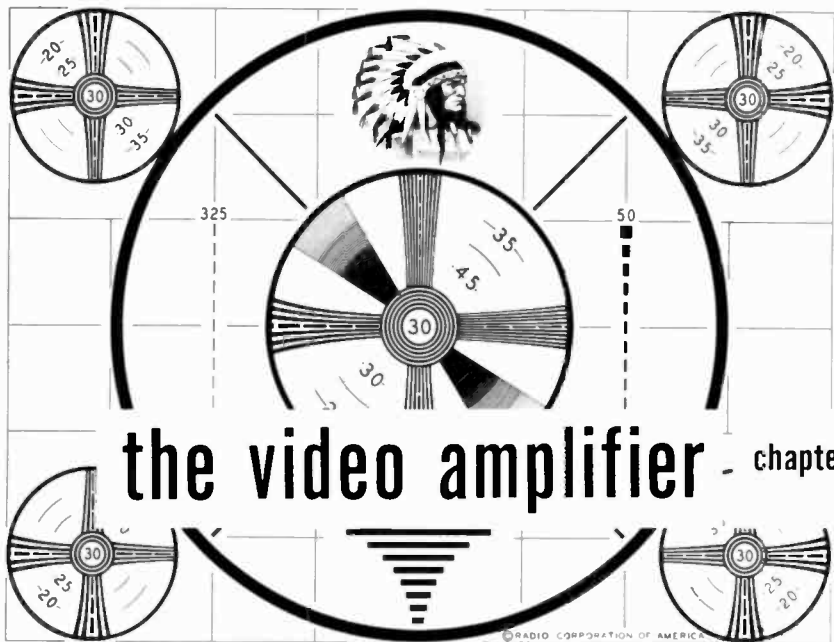

Fig. 501. In most TV sets the video amplifier is a single stage feeding either the cathode or control grid of the picture tube.



THIS chapter describes the last stage handling the combined video and audio signals. The video amplifier, in most receivers, is but a single tube (some sets use a two-stage video amplifier) directly coupled into either the control grid or the cathode of the picture tube (or through a coupling capacitor). The circuit is not as complicated in modern receivers as in older sets. The de restorer has been eliminated.

A defect in the video amplifier can result in trouble elsewhere, in circuits not normally thought of as being associated with the video amplifier.

A single symptom in a TV set may be due to a variety of causes. The important item, then, is to be able to recognize the different possibilities for a particular trouble. Once this is done you can localize the circuit by a process of elimination.

In Fig. 501 we have a block diagram of a television receiver. The portion covered in this chapter is indicated by the single block.

The purpose of the video amplifier is to strengthen the video signal to the point where the signal is large enough to be injected into the picture tube. The video amplifier is a separation point for sound, composite video signal for the control grid of the keyed agc tube, and a signal for the sync separator. This is shown in block diagram form in Fig. 502.

With such a circuit arrangement a defect in the video amplifier can result in trouble in the sound; sync (rolling and tearing);

video (a weak, washed-out picture), or trouble in the keyed agc circuit.

Video amplifier defects

Fig. 503 shows a typical circuit of a video amplifier stage. The signal is fed to the video amplifier tube from the video detector; it is amplified and applied to the cathode of the picture tube.

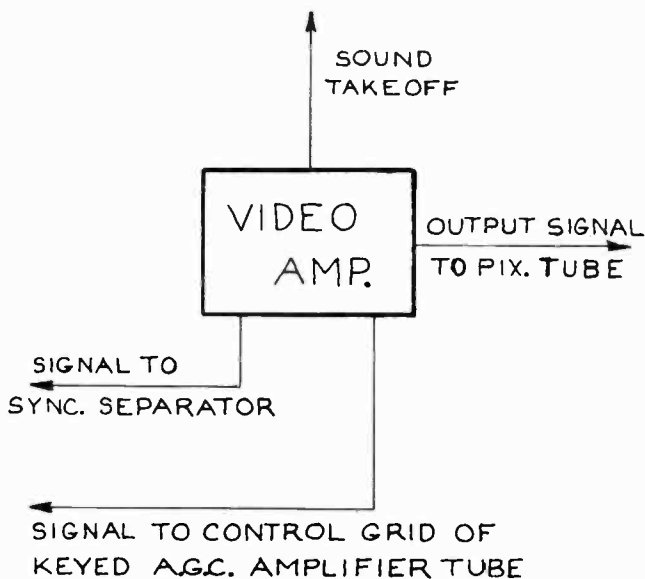

Fig. 502. *The video amplifier may be the distribution point for many signal voltages.*

This circuit does not show sync separation or sound takeoff, so we assume that the sync and sound have been removed prior to the video amplifier and therefore the only function of this circuit is to strengthen the video signal. Any defect in a circuit of this type, would affect the picture only.

Weak video

It is possible for the video signal to be sufficiently strong at the video detector diode load resistor and for the picture to appear weak. A weak video signal can be caused by a defect anywhere from the antenna up to and including the picture tube. The first logical step is to try to localize the trouble.

Here your best test instrument is your eyes. If the signal-carrying strip (front end, if, detector and video amplifier) is not in a series-string receiver (that is, if the filaments are operated in paral-

lel), look at the tubes. A signal can get through an rf or an if amplifier tube even if the filament is not lit, and, the higher the frequency at which the tube must work, the more easily this can happen.

Divide the signal-handling strip into two sections. The video-detector-diode load resistor is the dividing point. Tune in a channel and adjust the fine-tuning control for the best possible picture (even though the picture appears to be very weak). Measure

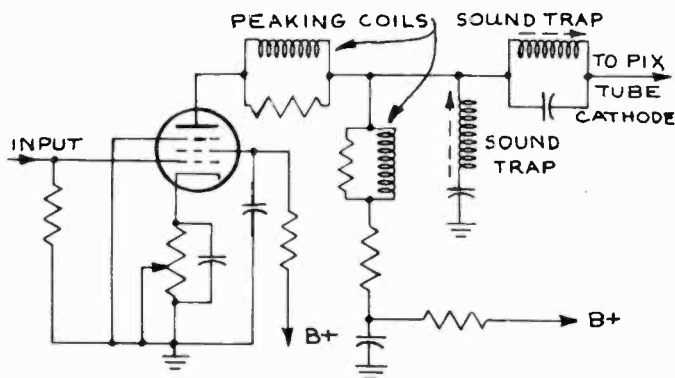

Fig. 503. Typical video amplifier circuit with shunt and series peaking coils and sound traps.

the voltage across the resistor. It should be at least 1 volt, peak to peak, preferably higher. If it is this value or more, then the trouble exists after the video detector stage. If it is less than this value, then the trouble is in the video detector or some preceding stage.

Another technique is to connect an AM signal generator to each tube control grid in turn, starting with the video amplifier and working your way back to the front end. Use a modulated rf signal having a frequency high enough to produce bars on the screen. The bars should get stronger as you work your way back to the tuner.

Typical video amplifier troubles

Probably the most common trouble in the video amplifier stage is tube trouble. Insufficient cathode emission is an expected fault, especially for tubes that have been in service for quite a while. Check by substitution.

Capacitor leakage

A typical R-C-coupled video amplifier stage is shown in Fig.

504. One trouble can be due to capacitors that have become leaky. C1, for example, has the double job of permitting the video signal to pass through to the cathode of the picture tube and blocking the B-plus on the plate of the video amplifier. The cathode of the CRT is also at B-plus. At first glance it might seem as though C1 is not needed. However, the voltage on the picture tube side of the capacitor is lower than that on the video amplifier side. A leaky C1 means a *higher* B-plus voltage on the cathode of the picture tube, raising its bias. This will affect the brightness. Of course, this could be compensated for by moving

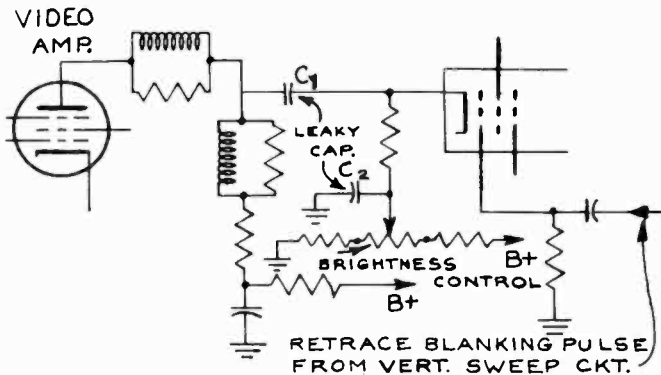

Fig. 504. A typical capacitance-coupled cathode-driven CRT circuit.

the brightness control to the left. However, by so doing, the amount of signal voltage injected into the cathode is reduced. The result is a picture that seems excessively bright with no setting of the brightness control able to bring the picture up.

C2 is essentially in shunt with the brightness control and the series resistor connected between ground and the control. If the leakage is small, the effect on the action of the brightness control may not be noticeable. If the leakage is high, brightness may become excessive and difficult to adjust with any setting of the brightness control.

C3 is a decoupling capacitor. It acts as an added filter for the power supply and helps minimize the possibility of feedback between the video amplifier and other stages connected to the B-plus bus. A leak in C3 would lower the B-plus applied to the plate of the video amplifier, reducing its gain and weakening the signal.

Measuring video amplifier bias

The usual method of measuring the bias on a video amplifier tube is to measure the dc voltage developed across the cathode-bias resistor. However, in some receivers, the control grid is also tapped to a fixed negative voltage point. In such circuits, the only correct way to measure the bias is to check the dc voltage between control grid and cathode.

Time-saver

To quick check the video amplifier, intermittently ground the control grid of the video amplifier tube with a screwdriver. This should produce flashes on the screen and, if the sound takeoff follows the video amplifier tube, also a scratching sound in the speaker.

Another quick check of the video amplifier is to apply 6.3 volts ac to the control grid of the video amplifier tube. This will produce hum bars on the screen. You can also modulate the video amplifier tube by applying an audio signal, usually available directly from the front panel of your signal generator.

The fact that a signal comes through the video amplifier and shows itself as one or more bars on the screen of the picture tube simply indicates that a signal is going through the video amplifier tube, but gives no indication of how well the video amplifier is working. When you have no picture on the screen, any one of these checks is valuable in determining if the video amplifier stage is responsible for blocking the passage of the picture signal.

Video amplifier tube trouble

If the video amplifier tube is completely open, then it is unlikely that any signal will appear on the screen. Should any one of the quick checks indicated earlier show no signal coming through to the picture tube, then test the video amplifier tube in a tube checker or substitute a new tube for the one in the receiver.

The video amplifier tube is *almost always* a glass type. Examine the tube carefully. Notice if it has any cracks near the base. Check the pins to make sure that they are not broken or so bent out of shape that they do not make proper contact. A whitish deposit inside the tube near the base indicates the presence of gas. A gassy tube can result in a complete absence of picture or at least make the video amplifier behave as though it had poor low-frequency response, resulting in smear.

When the picture tends to be unstable — that is, if the picture

jitters, or portions tear out — the trouble might be due to a microphonic video amplifier tube. Tune to a good channel and tap the tube gently with the rubber end of a lead pencil. If this produces bars in the picture, causes jitter or tearing, then the tube is microphonic and should be replaced.

Do not confuse hum bars in the picture with sound bars. Sound bars change with the intensity of modulation and are much finer



Fig. 505. *Video if, detector or video amplifier trouble is indicated if a weak washed-out picture has no snow.*

in appearance than hum bars. Hum bars in the picture may be due to heater-to-cathode leakage in the video amplifier tubes. It is best to check by tube substitution.

A weak video amplifier tube can produce a variety of symptoms. Note the setting of the contrast control. If, for all channels received on the set, the contrast control must be kept at or near its maximum position, then a weak video amplifier tube is indicated. Another symptom of a weak video amplifier tube is a weak picture with critical sync on all channels. Probably the fastest and easiest check in all of these instances is tube substitution.

It is also possible that a receiver may produce a very weak picture but with sync locking the picture into place. Obviously, if the sync takeoff precedes the defective video amplifier tube, then the tube cannot affect the sync. If, however, the sync takeoff is part of the video amplifier tube circuit, then it is possible for the sync to be affected. This is another instance in which the circuit

diagram is extremely helpful in diagnosing the trouble in the receiver.

Loss of gain

A weak video amplifier tube can result in the condition shown in Fig. 505. Note that although the picture is weak, there is no snow in the picture.

A weak, washed-out picture means a loss of gain in the video if stage, the video detector or the video amplifier. Should you have the same picture but with excessive snow on all channels, then the trouble would most often be due to the rf amplifier or to the agc network controlling that rf amplifier, or a defective antenna.

Contrast-control troubles

In some receivers, the contrast control is the cathode resistor of the video amplifier tube. (It is also used in the plate circuit in a few receivers.) Here, the contrast control determines the amount of current flowing through the tube. To check the contrast control, tune in the strongest channel. Adjust the receiver carefully for a good picture. Rotate the contrast control completely counterclockwise. The picture should disappear completely. Now slowly turn the contrast control clockwise. Somewhere before the end of its rotation, the picture should reach maximum contrast and then become quite black. If this is the case, the contrast control has an effective range. Turn the contrast control back to its starting position again and rotate it rapidly while watching the picture. The action of the contrast control should produce no streaks, flashes, picture breaks or jumps. If it does, then it is possible that the contrast control is worn or dirty. Try cleaning the control with a commercially available lubricant-cleaner, or replace the unit.

When the contrast control unit is used as the cathode resistor for the video amplifier tube, another resistor is sometimes placed in series with the contrast control to insure a minimum amount of bias for the video amplifier tube. If this resistor in series with the contrast control should become shorted, it would have a tendency to make the setting of the contrast control very critical. However, if either the contrast control or its series resistor should open, the result would be a complete loss of picture on the screen.

Peaking coils

A typical video amplifier stage may use one or two peaking coils. Generally wound on resistor bodies and wired in parallel

with them, the overall resistance as measured with an ohmmeter should range somewhere between 1 and 15 ohms. The purpose of the resistor is to broaden the response of the coil. The job of the peaking coil is to extend the high-frequency response of the video amplifier stage. Fig. 503 shows series and shunt peaking coils in a typical video amplifier circuit.

Replacing video peaking coils

The video peaking coil should be an exact replacement and should be wired into the same position formerly occupied by the defective coil. Peaking coils may look alike but differ very widely in their characteristics. Peaking coils range in inductance from as little as 22 to as much as 495 millihenries. The dc resistance of peaking coils extend from as little as 1.2 to as high as 14.2 ohms.

There is no relationship between the dc resistance of a coil and its inductance. We emphasize this point because some service technicians make a resistance check of a peaking coil and then replace the coil with another unit having a similar amount of resistance. This procedure is absolutely incorrect. The following table shows the resistances of various peaking coils and their inductances.

<i>Resistance In Ohms</i>	<i>Inductance in Millihenries</i>
1.2	237
1.8	22
1.8	165
2.8	22
6.0	165
6.2	193
6.2	360
6.5	105
7.7	139
8.0	153
11.6	495
14.2	360

You can see from this table that a coil having a resistance of 1.8 ohms can have an inductance of 22 or 165 millihenries. These coils cannot be considered substitutes for each other.

Picture smear

An open peaking coil can result in a severe case of picture smear, as shown in the photo of Fig. 506. Adjustment of the fine-tuning control has no effect on this condition.

The effect of an open peaking coil is to increase the gain of the

video amplifier stage. This is true of both the series and shunt peaking coils. Check the peaking coil with an ohmmeter. The resistance should be less than 20 ohms. If an ohmmeter reads the value of the resistance on which the peaking coil is wound, the coil is open.

An open peaking coil is also indicated when the plate voltage on the video amplifier is lower than normal. In the case of a



Fig. 506. Poor video amplifier low-frequency response is characterized by picture smear.

direct-coupled video amplifier (directly connected to the cathode of the picture tube), this decrease of video amplifier plate B-plus voltage means less B-plus on the picture-tube cathode, hence increased picture-tube brightness. If the picture-tube brightness is excessive and no setting of the brightness control can reduce it, an open peaking coil is a possible source of this trouble.

Overpeaking

Overpeaking means that somewhere in the frequency response curve there is a strong boost. This can occur anywhere from the first video if up to the input to the picture tube.

You can get a variety of symptoms from overpeaking. The test pattern in Fig. 507 shows some of its effects. This trouble sometimes produces a series of stripes across the screen or an extremely poor, unstable picture. Sometimes the picture is completely lost.

Overpeaking may cause oscillation by positive feedback. Then

the video amplifier is acting as an oscillator and not as an amplifier. Actually, the tube can do both. It can act as an amplifier for part of the video-frequency range and oscillate over a small range of frequencies.

It is also possible for regeneration to take place without oscillation. With regeneration the tube behaves as an amplifier but supplies considerable amplification over the band of frequencies at which regeneration is taking place.



Fig. 507. *The effects of overpeaking.*

This can be caused by a shorted decoupling resistor in the B-plus bus going to the video amplifier or by an open decoupling capacitor in the same bus line. Also check the screen bypass capacitor. Shunt it with a known good unit to see if it will minimize or eliminate the trouble. Sometimes servicing produces this trouble if lead dress is disturbed (plate and control grid leads brought too close to each other).

Hum

A quick way to check for which stage is causing hum to appear in the picture is to remove tubes, starting with the video amplifier. (This applies to tubes whose filaments are heated in parallel.) If removing the video amplifier tube has no effect on hum in the picture, the trouble can very well be due to heater-cathode leakage in the picture tube. If the hum in the picture disappears, re-

place the video amplifier tube and remove the last if amplifier tube. If the hum remains, then the trouble is either the video detector or in the video amplifier. Try substituting new tubes.

If the horizontal edges of the picture are not wavy but straight, the hum (Fig. 508) is probably in the video detector or the video amplifier (in cases where the sync takeoff precedes these circuits). If the edges of the picture are wavy, the hum is affecting the sync

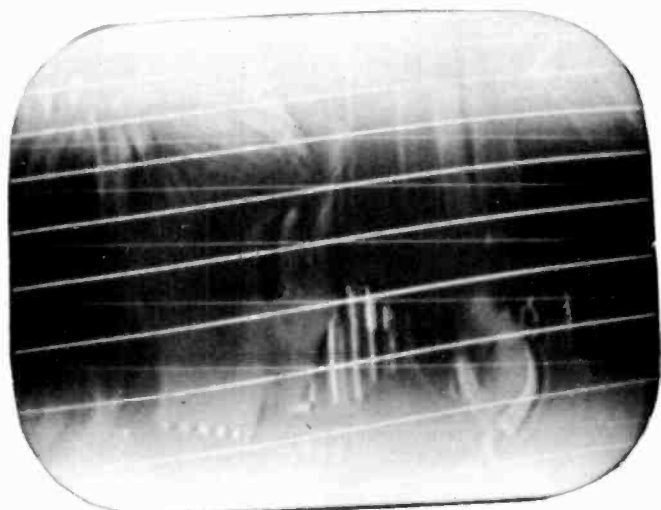

Fig. 508. If hum exists in a stage that follows the sync takeoff point, the sides of the raster are not affected.

circuits and arises in those tubes or circuits preceding the sync takeoff point.

You can use your scope for checking each stage where filament connections do not permit tube pulling. To determine if the hum is in the picture tube or video amplifier stage, connect the vertical input terminals of the scope to the input of the picture tube (this can be the cathode or the grid, depending on the circuit arrangement of the particular receiver) and then to the control grid of the video amplifier tube. Fig. 509-a shows a normal video signal while Fig. 509-b is a video signal having a 60-cycle hum. Fig. 509-c shows the signal modulated by 120-cycle hum.

Set the sweep frequency control on the oscilloscope to 30 cycles. If the waveform on the scope shows a single cycle, then the hum frequency is 60 cycles. If the scope waveform shows two cycles, then the hum frequency is 120 cycles. Knowing the frequency

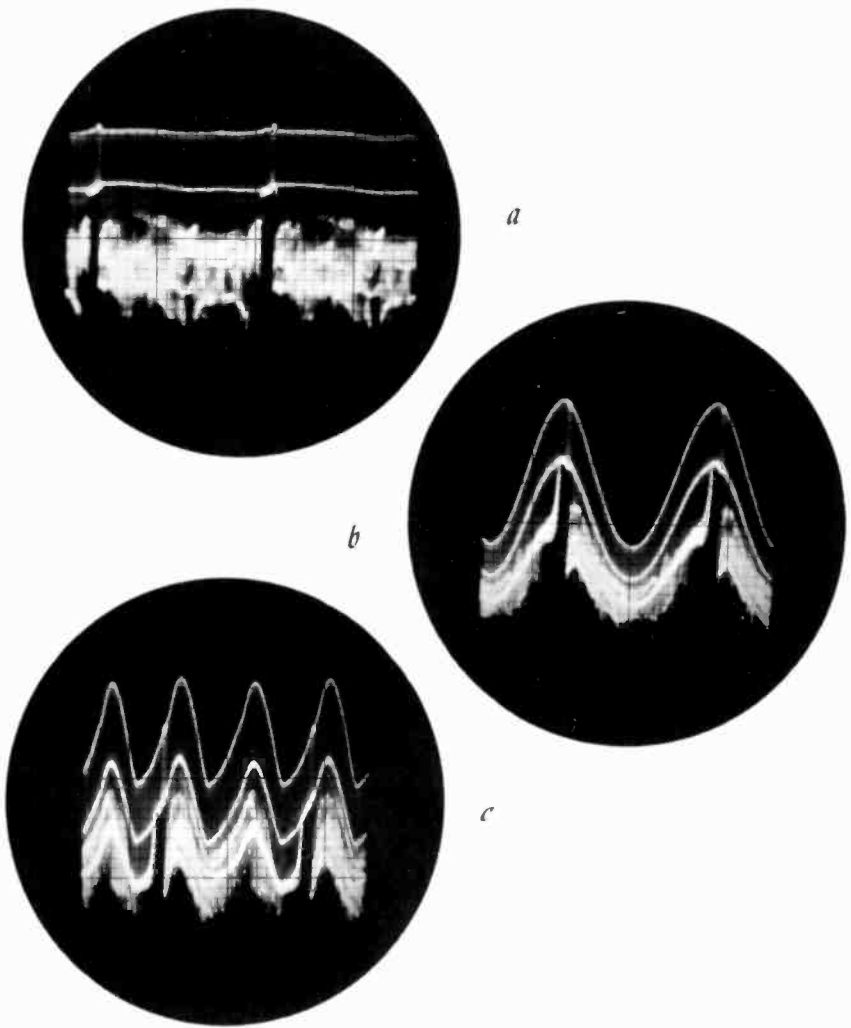

Fig. 509. Normal waveform (a), with 60-cycle hum (b) and 120-cycle hum (c).

of the hum will help you locate it. 120 cycle hum is produced by some defect following the rectifier in the low-voltage supply. An open filter capacitor in the B-plus bus to the plate of the video amplifier could result in 120-cycle hum. However, 60-cycle hum can come from heater-cathode leakage or hum voltage picked up by the control grid of the video amplifier from the heater bus.

Sound bars in picture

This annoying complaint can often be traced to a misaligned sound trap in the video amplifier circuit.

Turn the receiver on and adjust the controls until the sound bars are quite pronounced. Adjust the tuning slug of the sound trap with an insulated alignment tool. Rotate the slug and observe the bars. Generally, a trap can be adjusted by watching its effect on the picture.

The sound trap or traps can be inserted almost anywhere in the video amplifier circuit. If the trap is connected between the control grid and the chassis, it is of the series-resonant type — that is, it consists of a capacitor in series with a coil. If, however the trap is inserted in the signal path, it is of the parallel-resonant

Fig. 510. Typical direct-coupled cathode-driven CRT circuit.

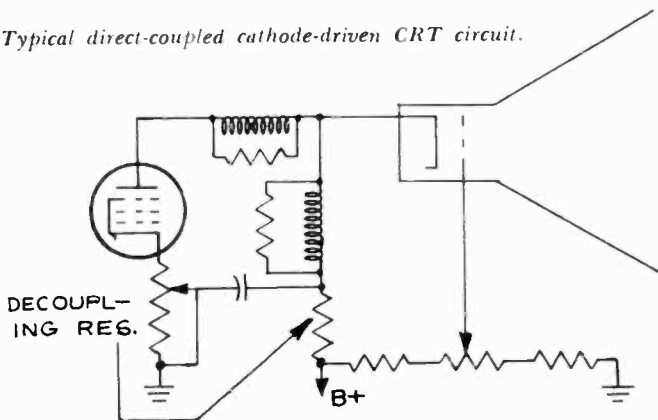

type — consisting of a coil and capacitor in shunt or parallel. In some receivers, the trap is also made to act as the sound takeoff point for the sound if amplifier. In some of the older receivers, you may find the trap adjusted by a small variable capacitor. But practically all sets today use movable iron slugs.

Sound-trap troubles

If the coil of the parallel-resonant sound trap located between the plate of the video amplifier tube and the cathode-ray tube should open, the effect would be to kill the picture. On very strong stations, with the contrast control advanced to maximum, some very small amount of picture signal might get through. If the sound trap is also used as a sound takeoff point, the sound would be lost.

Check the trap with an ohmmeter. The resistance reading will be that of the coil. Another check is to rotate the slug of the trap while watching the picture. If, by turning the slug, you can produce sound bars in the picture or can eliminate them, then the

trap is working properly. If not, the trap should be checked further.

The same checks can be made on the series-tuned type of sound trap.

Cross-modulation buzz

This type of buzz is not fixed but changes in strength as you go from channel to channel, or may even change in strength while on a single channel. The tone of the buzz (low to high and back again) will also change. The trouble is most often caused by a defective tube handling both sound and video signals. Substitute tubes one at a time, working back toward the front end of the receiver.

Sound, no picture

In many receivers, direct coupling is used between the video amplifier and the input electrode of the picture tube. A typical circuit is shown in Fig. 510. In this circuit, the B-plus voltage on the plate of the video amplifier tube is lower than the B-plus voltage at the output of the power supply because of the voltage drop across the decoupling resistor. Any defect in the video amplifier tube that prevents current from flowing through the tube (open cathode resistor, open filament, defective tube) causes the voltage on the plate to rise. This increased positive voltage is passed on to the cathode of the picture tube. If the cathode is made excessively positive, the screen will be blank (no raster). No setting of the brightness control will restore it.

If the sound takeoff point precedes the video amplifier tube, sound will be present. If the sound is taken off from between the video amplifier plate and the input to the picture tube, sound will be missing. When the sound is present but the raster is missing, you have a symptom which could be caused by the high-voltage supply. To check, remove the high-voltage connector from its terminal and spark the connector to the anode cup. A long spark here indicates that the trouble does not exist in the high-voltage supply.

You must realize by now that, for a relatively simple circuit, the video amplifier can pose quite a few problems.

Oscillation suppressor

In a few receivers you may find a low value resistor (generally 100 ohms) in series with the control grid of the video-amplifier tube. The purpose of this resistor is to introduce resistance into

the grid circuit of the amplifier, reducing the possibility of parasitic oscillation. In many instances, you can short this resistor and not note any difference in receiver operation. The fact that the video amplifier does not oscillate when a weak station is pulled in does not mean that it cannot be pulsed into oscillation when strong sync pulses excite the control grid.

Screen dropping resistor

The bypass capacitor for the screen dropping resistor is usually an electrolytic having a value between 5 and 10 μf . When it

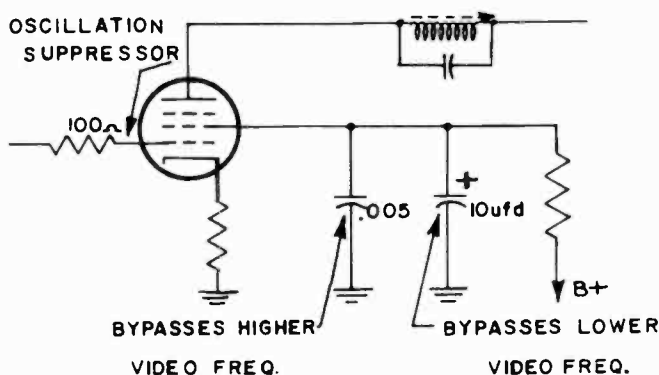

Fig. 511. Electrolytic capacitor may be paralleled with a small paper or ceramic type at the tube socket for better high-frequency decoupling.

is leaky or shorted, the current flowing through the screen dropping resistor increases. Look for resistors that are hot, discolored or smoking. Disconnect the capacitor and replace the resistor. If the replacement remains cool after a period of operation, substitute a new filter capacitor. If the capacitor is one section of a multi-section capacitor, simply clip the lead from the defective section and replace it with a single-section electrolytic connected between screen grid and chassis.

Sometimes a smaller value capacitor is also connected between screen grid and chassis. A value of .005 μf is typical. Since this capacitor is effectively in shunt with the electrolytic and because it adds very little to the overall shunting capacitance between screen grid and ground, there may be some tendency to regard it as an unnecessary unit. It does however, serve a useful function.

The purpose of a capacitor at the screen grid of the video amplifier tube is to help put that electrode at ground as far as the video

signal is concerned. The electrolytic serves very well for lower video frequencies but not for the video frequencies above 2 mc. Hence the need for a small-value bypass that can do the job. (See Fig. 511.)

Local-distance switch

The voltage on the screen grid of a pentode has a considerable influence on the gain of the tube. Some circuits incorporate a switching arrangement so the voltage on the screen grid of the

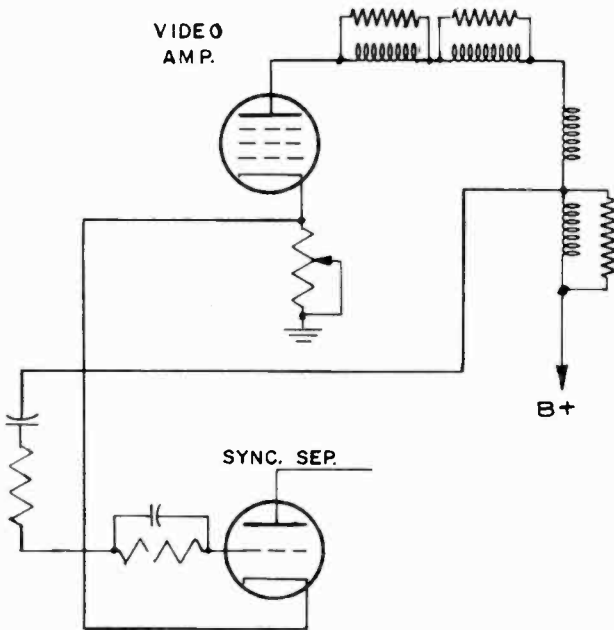

Fig. 512. Video amplifier cathode resistor also supplies sync separator bias.

video amplifier tube can be varied for a signal area. Be sure to examine the rear apron of the receiver to determine if it is equipped with such a switching arrangement.

At the same time that the switch changes the voltage on the screen of the video amplifier tube it operates to change the bias of the rf amplifier. Only for weak areas, is the agc bias removed from the rf amplifier.

Common components

Sometimes a resistor or capacitor is used by two separate re-

ceiver stages (Fig. 512). The cathode resistor for the video amplifier tube (contrast control) is common for both video amplifier and sync separator. The contrast control resistance supplies the bias for both tubes. The bias is the result of the total current flowing through both tubes. Here a weak sync separator tube, can cause not only critical sync but a weak picture or a higher than normal contrast control setting. We normally would not associate a weak picture with the sync, but rather with the video if or video amplifier tubes.

The setting of the contrast control compensates for reduced

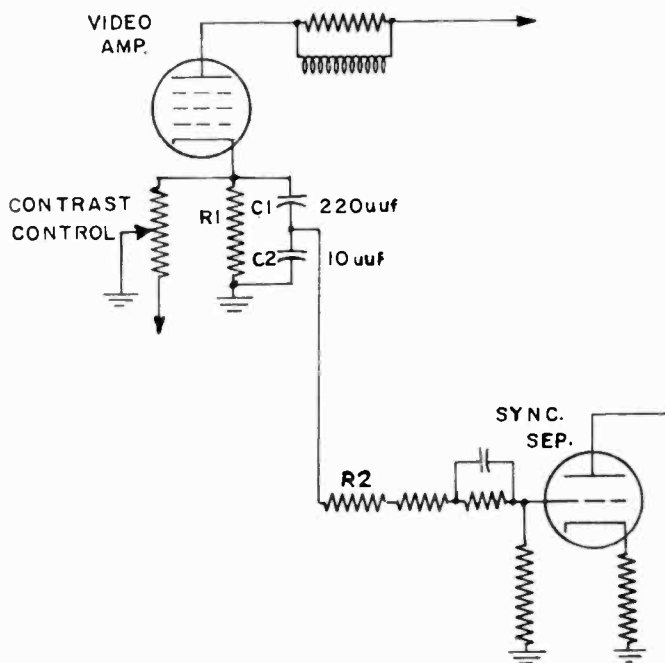

Fig. 513. Sync separator signal voltage is obtained from video amplifier cathode through a capacitive voltage divider.

emission. As emission is reduced, the contrast control is adjusted to reduce the bias and to bring the emission up again. However, reduced emission does not happen in equal amounts in two different tubes. In a circuit of this type the best contrast control setting for a good picture may not be the best setting for stable sync. Conversely, the best lock-in point for sync may not be ideal as far as the picture is concerned.

In a circuit of this sort, it is usually best to replace both video amplifier and sync separator tubes at the same time, to avoid the possibility of an early callback.

Capacitor voltage divider for sync

In Fig. 513 two capacitors, connected in series, are used as a voltage divider across the cathode resistor. The proper amount of sync voltage depends upon the ratio of the capacitance of C1 and C2. Note also that the contrast control and R1 are in parallel. Circuits in which the contrast control is the cathode resistor of the video amplifier, an open control means loss of picture. In

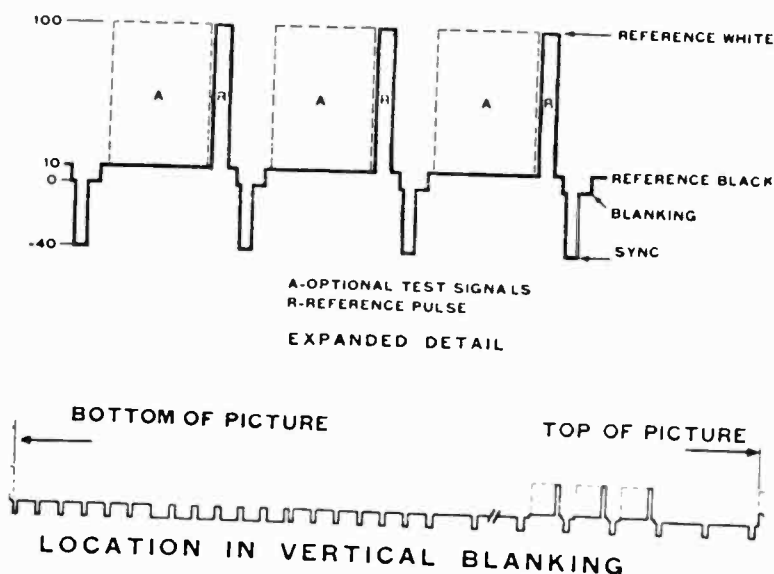

Fig. 514. The white-reference pulse (R) provides a maximum level standard. The space (A) adjacent to and leading the white-reference pulse can be utilized for other test signal transmissions. (CBS Television)

Fig. 513 an open contrast control would mean a weak picture, and loss of proper control but a completely open circuit would not exist.

In the circuit of Fig. 5, C1 keeps the dc voltage, developed across R1, from being placed on the control grid of the sync separator.

Poor focus

Sometimes a picture may seem to have poor focus and yet the trouble may not be focus. Examine the raster. If the horizontal

sweep lines are clear and sharp, but the picture seems out of focus when the channel selector is turned to an active channel, check the video amplifier.

Unstable sync

Since the video amplifier tube supplies the CRT input with the maximum signal, but a much smaller signal voltage for the sync separator, it is entirely possible for a CRT to show a mod-

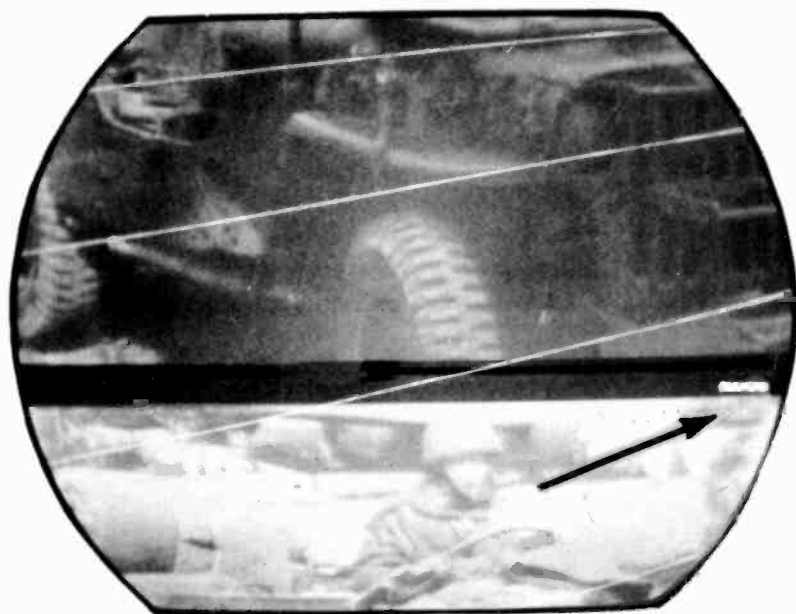

Fig. 515. The small white box near the top of the raster is the white-reference pulse as it appears on the CRT raster. Brightness has been increased to show the relation of white reference to the sync pulse

erately good picture but for the sync to be critical. The trouble may be due to a weak video amplifier tube.

Effect of video amplifier on keyed agc

In an agc keyer circuit, the plate of the keyer tube receives its voltage from the width coil. The control grid of the agc keyer gets its signal voltage from the video amplifier tube. If the video amplifier tube is weak (insufficient cathode emission), the voltage delivered to the agc keyer control grid is reduced. This causes more current to flow through the agc keyer tube. This increases agc bias, resulting in snow, poor contrast and critical sync. With

snow and poor sync, the usual inference is that the rf amplifier tube is weak—and this is often the trouble. However, if the bias on the rf amplifier is above normal, then the difficulty can be due to a fault in the agc network. Where the agc keyer tube gets its bias from the video amplifier, consider the video amplifier as part of the agc network and not simply as a tube that amplifies picture and sound signals.

Trailing reversal (white following black)

This is a condition of smear and is due to causes described earlier in this chapter.

Echo effect

This is a form of oscillation that can occur in the video amplifier. It is known as ringing and can be identified by a succession

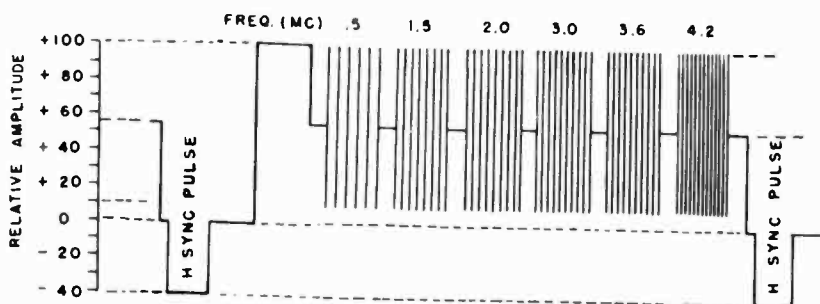

Fig. 516. Frequency-burst signal waveform for one horizontal line. The time base is not to scale and the bursts are not necessarily equal in width. (CBS Television)

of vertical lines in the picture. (See the section on overpeaking, in this chapter.)

Dim picture

Sometimes doubt may exist as to whether a dim picture is due to high-voltage trouble, picture-tube trouble or a weak video amplifier tube. If the raster is strong and the brightness control can vary the raster from cutoff to brilliant scanning lines, then both the high-voltage and the brightness controls are functioning. The dim picture can be due to a weak video amplifier tube. (We can vary the raster from cutoff to brilliant scanning lines, then just described.) If the voltage across the video detector load resistor is normal, then the trouble is in the video amplifier. Sub-

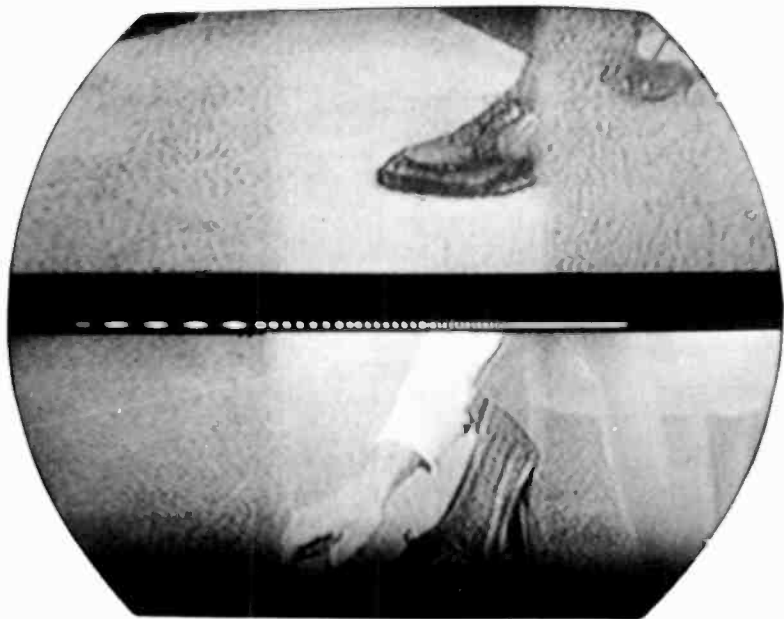

Fig. 517. Blending of the white dots indicates the upper limit of the frequency response as seen on the CRT.

stitute a new tube and, if this doesn't help, make voltage and resistance checks in the video amplifier circuit.

Picture jumps out of sync on strong stations

If the picture locks in on weak and moderate signals but not for strong stations, a condition of sync overload exists. Overload isn't always suspected since the picture on the screen may not show typical overload symptoms. However, the sync separator may be overdriven. Try a smaller value of coupling capacitor between the sync input and the output of the video amplifier. Also try connecting a small trimmer capacitor having a range of about 7 to 35 μf between control grid and ground of the sync separator. Adjust the capacitor until the condition disappears.

Picture pullout

This condition can be caused by defective coupling capacitors between the video amplifier and the sync separator. This can also be due to a defective video amplifier tube. If all components and the video amplifier tube seem good, then it may be due to exces-

sive signal input to the video amplifier tube resulting in sync limiting.

More about waveforms

Some strange spikes may be observed in the waveforms during the retrace periods on the *back porch* of the blanking pedestals.

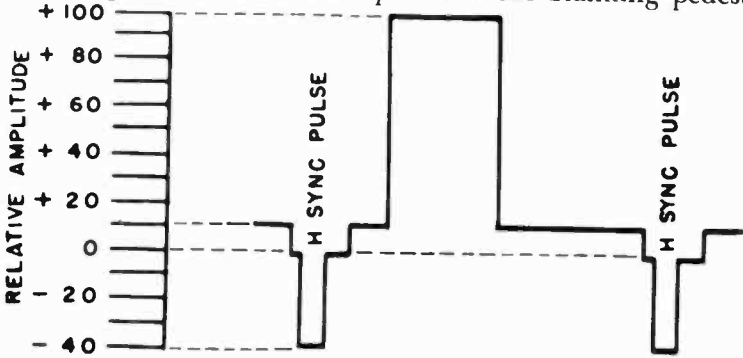

Fig. 518. Waveform of one horizontal line of blanking pedestal with bar signal inserted. (CBS Television)

These additions to the more familiar waveforms are not defects or distortions, but well engineered and FCC approved additions for the use of TV broadcast technical personnel. Broadcast on a schedule, they are used to check the operation and characteristics of the equipment and their connecting circuits.

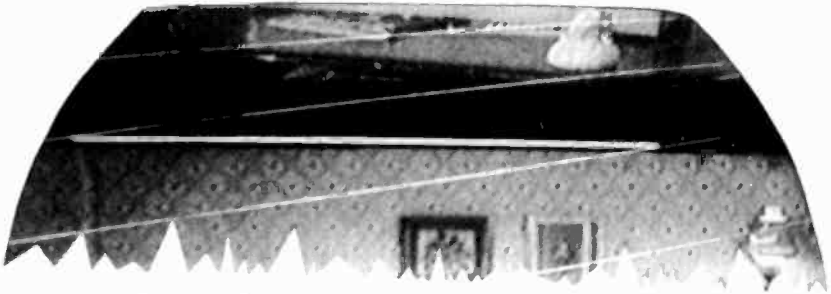

Fig. 519. Bar signal as it appears on the blanking pedestal in relation to the sync pulse, with the brightness increased to make it visible.

Added to the blanking pulses, they are not normally visible on the raster of a properly filled CRT screen. To view these pulses, it is necessary to lower the picture or decrease the size until the upper edge of the raster is visible.

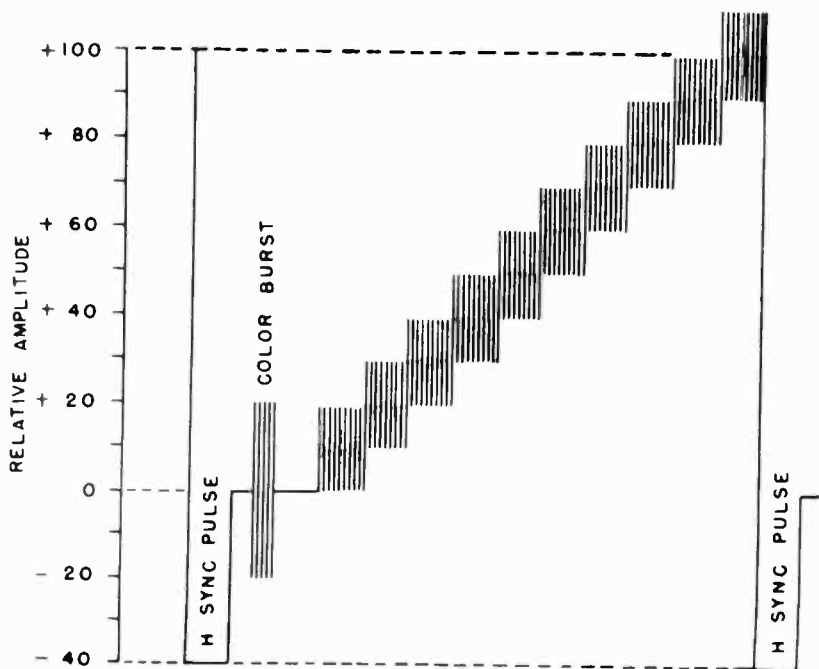

Fig. 520. Combined step wave and 3.58-mc signal is the stair-step signal. The steps are in equal increments. The time base is not to scale. (CBS Television)

White-reference pulse

Among the signals inserted in the blanking intervals are the reference pulses. These are used by the networks as an aid in maintaining proper video signal levels. Most of the responsibility for the adjustment of video levels rests on the camera control operator. In low-key scenes such as night sequences, a white-signal peak may not be available, leaving the setting of many amplifier controls throughout a network to the educated guess of the operator. Therefore, the white-reference pulse (Fig. 514) is considered the most important to network operation. These white pulses, corresponding to the maximum picture intensity, are inserted at the top of the raster (Fig. 515) where, taking advantage of the CRT mask curvature, they present minimum visibility even on underscanned receiver screens.

Frequency burst signal

The amplitude-frequency response, as well as signal level, of

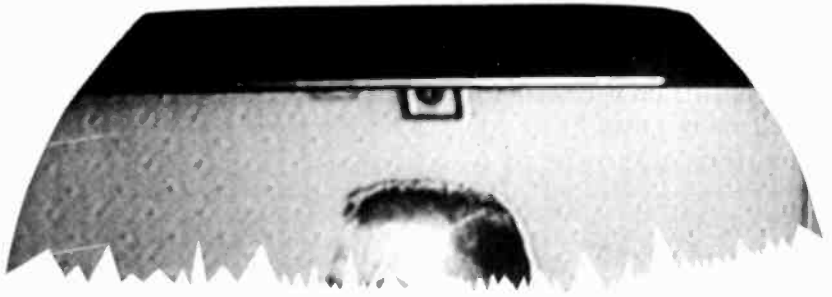

Fig. 521. *Stair-step signal gray scale as seen on CRT. Brightness has been adjusted for normal viewing.*

the system and individual amplifiers is also important in video transmission. Groups of several cycles each of 0.5, 1.5, 2.0, 3.5, 3.6 and 4.2 mc are inserted in the third, fourth and fifth lines from the end of the vertical blanking period. One such line is shown in Fig. 516. By observing the crispness or blending (Fig. 517) of these white dots, it is possible to evaluate roughly, the high-frequency response visually, at the viewing screen.

Bar signal

The amplitude-frequency response at low frequencies (below 0.2 mc) must also be checked continually. Rectangular signal pulses at the line frequency (Fig. 518) are inserted to form a horizontal white bar in the trailing portion of the vertical blanking signal and appearing at the top of the raster (Fig. 519).

Stair-step signal

A sine wave of 3.58 mc is superimposed on the basic step-

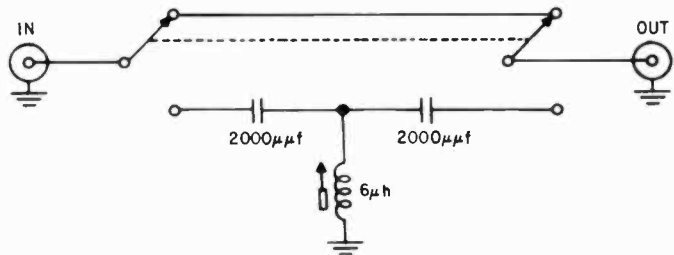

Fig. 522. *Switching circuit and high-pass filter allow 3.58-mc sine wave to be viewed with or without step wave. (CBS Television)*

wave signal (Fig. 520). This composite signal appears on the CRT screen as a 10-step gray scale from black to white. (Fig. 521). To eliminate differences in brightness and contrast setting and viewing on various CRT screens, a method is used that eliminates many possibilities for operating error. A simple high-pass filter (Fig. 522) is inserted in series with the monitoring scope.

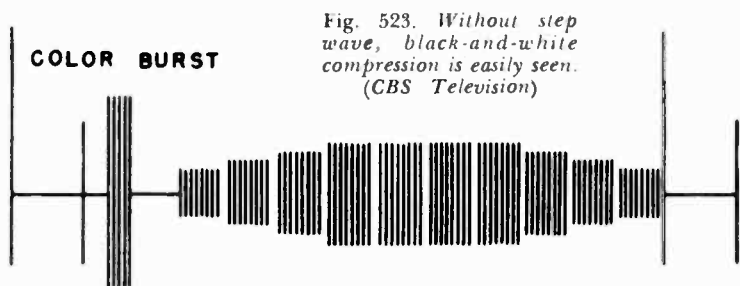

Fig. 523. Without step wave, black-and-white compression is easily seen. (CBS Television)

The step wave is removed and an in-line presentation makes compression of either the black or white signals obvious (Fig. 523).

Since all of these steps are of equal duration, they can be used also to approximate the linearity of the horizontal sweep.

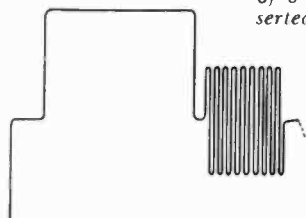

Fig. 524. Color subcarrier is a minimum of 8 cycles of 3.579545-mc sine wave inserted in the back porch of the horizontal blanking pedestal.

Color burst signal

For color TV, a minimum of 8 cycles of a 3.579545-mc sine wave is inserted in the blanking pedestal's back porch (Fig 524) and referred to as the color subcarrier. Remember that, during a color program broadcast, the scanning rate is changed to 15,734.264 cycles per second and the vertical frequency is reduced to 59.94 cps. The frequency of 15,734,264 was chosen to provide a minimum of interference beat patterns between the color subcarrier of 3.579545 mc and the sound channel. These values being quite close to the 15,750 and 60 cps for black-and-white, there are usually no sync problems in properly operating receivers.

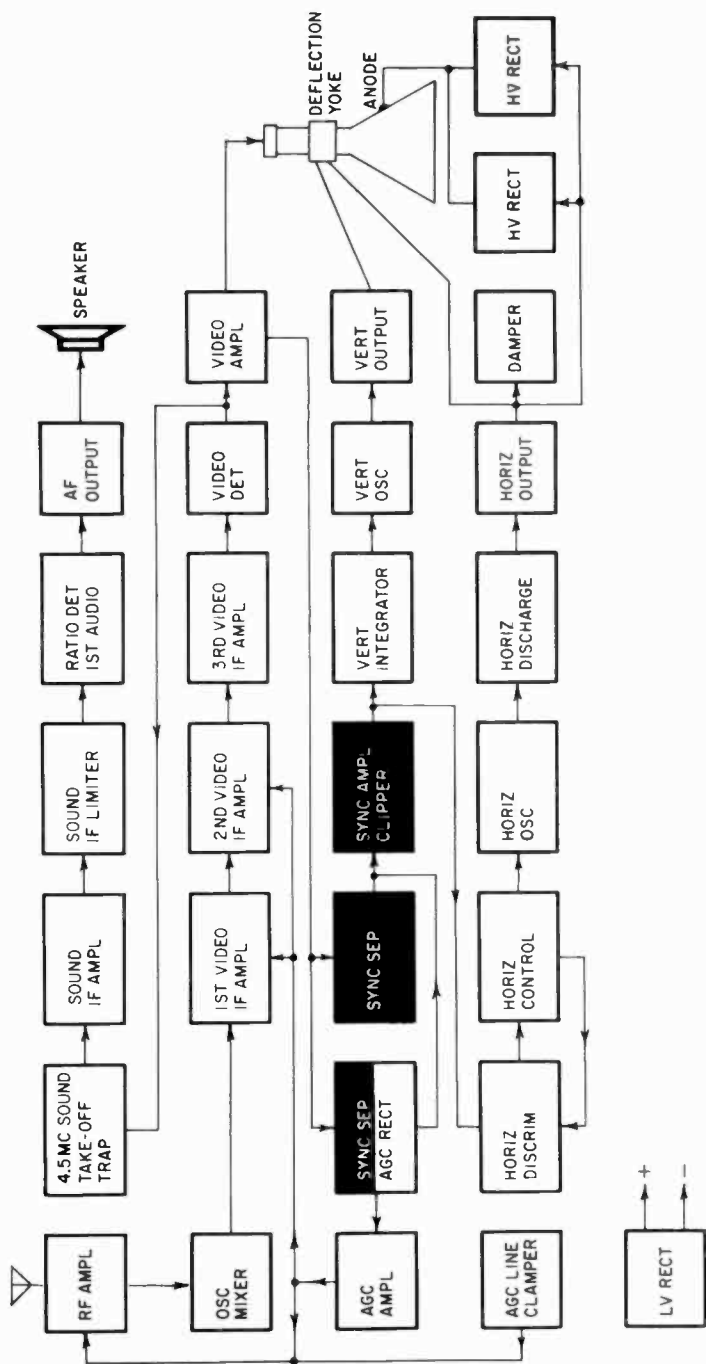

Fig. 601. Troubles such as rolling, tearing, shimmy and jumping can be caused by some defect in the sync circuits.



sync troubles

chapter 6

AFTER the output of the video amplifier, our video signal follows two paths. One leads to the picture tube and the other to the sync separator. When you examine the diagram in Fig. 601, you may not recognize the fact that there is a voltage divider right across the output of the video amplifier. At the top end of this voltage divider, is the picture tube. The whole purpose of the rf, if and video amplifier tubes has been to build the signal to a point where it is strong enough to operate the picture tube. And so we feed our picture tube the maximum video signal.

Much less voltage is needed to operate the sync separator. The video voltage is taken from an R-C network connected between the video amplifier plate and ground. This network, not only supplies the right amount of composite video signal to the sync separator, but also acts to decouple the picture tube and the sync separator tube (Fig. 602).

There are quite a variety of sync circuits used in television receivers. It is impossible to describe all of them, but we will try to cover those used in the majority of receivers.

Sync troubles

The scanning beam in the home television picture tube must always be exactly in step with the scanning beam in the camera tube at the television station. Scanning of the two tubes is kept in step or synchronization (commonly abbreviated as sync) by the horizontal and vertical sync pulses transmitted along with the

video signal. If anything happens to these pulses either at the transmitter or at the receiver the picture will roll (this indicates loss of vertical sync) or it will tear (indicating loss of horizontal sync) or it may do both (meaning that both horizontal and vertical sync pulses are not as they should be).

The complexity of the sync section in a TV receiver depends entirely upon the particular manufacturer and varies from one

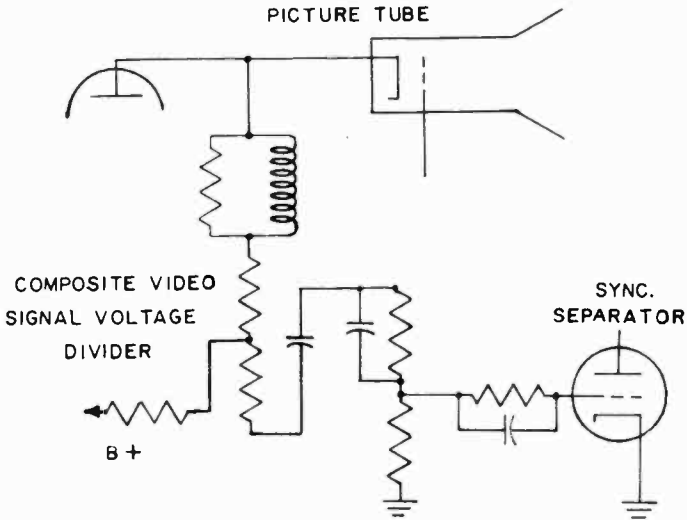

Fig. 602. *The level and frequency response of the signal fed to the sync separator is lower than that fed to the CRT.*

model to the next of the same manufacturer. The sync circuits may include (1) a sync separator (also called the sync stripper) whose function is to remove the sync pulses from the composite video signal; (2) a sync clipper to give uniform sync pulse amplitudes; (3) a sync amplifier to strengthen the pulses; (4) a noise-pulse control circuit to reduce noise in the sync.

Sync-takeoff point

In most modern receivers, the sync is taken off after the video amplifier and, since the majority of sets use but one video amplifier, the sync takeoff is somewhere between the video amplifier output and the input to the picture tube. In older receivers you may find sync takeoff as part of the dc restorer circuit.

Sync separator

The purpose of the sync separator is to remove the sync pulses from the composite video signal. A simple circuit is shown in

Fig. 603. Note that the cathode is connected directly to chassis and that the tube is biased by grid-leak resistor R1. The positive signal arriving at the control grid makes the grid positive. The positive grid (behaving like a plate) draws current, and it is this current flowing through R1 to ground that develops the voltage for biasing the tube. C1 helps maintain the bias. With low plate voltage and comparatively high bias the tube is in the cutoff

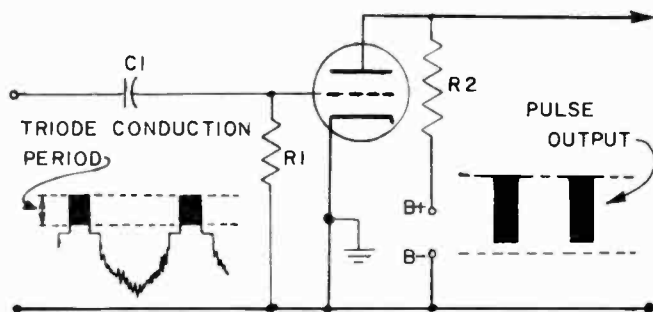

Fig. 603. The sync separator is cut off for all signal voltages below the blanking level — only the sync pulses are amplified. The output signal voltage is inverted by the tube.

region for most of the time and is driven out of cutoff only by the arrival of the most positive portion of the composite video signal, the sync pulses. These are shown in the output, inverted and amplified. The clipper works as a diode-triode with the cathode and control grid working as the diode, and the cathode, grid and plate operating as the triode.

Sync voltages

The voltage on the plate of the separator is usually quite low and ranges from about 20 to as much as 100, depending entirely upon the particular circuit.

The bias voltage ranges between a low of -0.7 volt in some sets to as much as -18 in other receivers. A typical value of grid-leak resistance is 2.2 megohms.

The composite video signal at the input to the separator usually has a peak-to-peak value between 50 and 100 volts.

Sync-voltage measurements

When the picture shows complete loss of sync — that is, is rolling and tearing — there are a number of checks for sync separator operation. Connect a vtvm (set to read dc volts) between the control grid of the sync separator and ground. Tune in a channel and note the bias voltage. Then turn the station

selector to an off-channel position. The bias voltage should drop almost to zero. If this action takes place, then the composite video signal is reaching the control grid of the separator. When tuned to a channel, note the bias voltage, and compare it with that shown on the manufacturer's schematic. Make a further check on the plate side of the tube by measuring the plate voltage with and without signal input. With a signal on the control grid, the plate voltage should be high; without a signal, the plate voltage should be very low.

Using the scope

Use a scope with a low-capacitance probe. Touch the probe to the input and then to the output of the separator tube. (You can use a direct cable instead of a low-capacitance probe, but the direct cable will not show the pulses as they actually exist. When



While a wide-band scope is not necessary to detect the presence of sync pulses the greater bandwidth will be more likely to present waveforms approaching the idealized drawn versions. (Allied Radio Corp.)

just interested in determining the absence or presence of the sync signals, this technique is good enough). Set the scope sweep to 30 or 7,750 cycles.

On a typical oscilloscope, the sync-selector control has three positions — EXT (external sync) LINE and INT (internal sync). To observe 60-cycle pulse waveforms, you can set the sync selector on the scope to the LINE position. If the line frequency at the transmitter is the same as the line frequency at the shop, the waveform pattern on the scope will lock in. If it does not, then

set the sync selector on the scope to the INT position. The sweep range and sweep vernier controls should be set near 60 cycles.

Synchronize the scope at 60 or 15,750 cycles to observe the sync waveforms. Use 30 cycles on the scope, to see two vertical sync pulses, and, use 7,875 on the scope, to have two complete waveforms (7,875 is 15,750 divided by 2). Dividing 15,750 (this is horizontal sweep frequency) by 3, you will get a sweep frequency of 5,250 cycles. Setting the scope to this frequency will show three waveforms.

Use the scope to check on the efficiency of sync separation. At the input to the separator you should see the composite video signal. At the output of the separator you should find the horizontal and vertical sync pulses with video missing.

The first place to check is at the input to the sync separator. Compare the amplitude of the sync pulse to the peak-to-peak strength of the composite video signal. The amplitude of the sync pulses should be at least 25%. Pulses that are smaller is evidence of the sync-pulse compression — a condition that can result in unstable sync or loss of sync.

If the output of the sync separator, shows the same waveform as the input, the separator is working as an amplifier and not as a limiter. Using the wrong tube (a tube having a remote cutoff instead of a sharp-cutoff characteristic) or a higher than normal plate voltage can result in this trouble.

Triode separator trouble

Tube troubles are common. Check by direct substitution. Resistance check the plate load and grid leak resistors. These may have changed their values or become open. If the bias on the tube is not correct and remains incorrect even when the tube is changed, check the resistance and capacitance values in the grid circuit of the separator. The sync separator gets its composite video signal from the plate of the video amplifier. Check back on the R-C path to the video amplifier plate. Somewhere along this path is a coupling capacitor (.01 μf or larger). If this capacitor should become leaky, the bias of the separator will be reduced. To check, remove the sync-separator tube (if the receiver filaments are parallel-connected) and connect a vvm across the separator grid-leak resistor. A positive voltage on the control grid indicates coupling-capacitor leakage between the video amplifier plate and separator grid.

If a scope check does not show the presence of the composite

video signal at the control grid of the separator, use a low-capacitance probe and scope and trace the signal back to the plate of the video amplifier. If possible, tune the receiver to a test pattern when making this check. (Once accustomed to using the scope, it becomes the ideal instrument for chasing troubles in the sync section).

Sync compression

Because the sync pulses represent the maximum amplitude of the composite video signal, they are more readily subject to compression. Compression means that the sync pulses do not have their normal height (or amplitude). Thus, it is possible for the picture tube to get a normal video signal but for the sync pulses to be too weak to operate the sync separator properly. Sync compression results in poor sync stability. The picture may stay in sync and then suddenly roll or tear. Sometimes compression is severe enough to affect the video portion of the signal.

A scope and a low-capacitance probe are essential for checking on compression. It is necessary to calibrate the scope to permit you to read peak-to-peak voltages. Consult the manufacturer's schematic for peak-to-peak waveform amplitude at the input to the sync separator. Then use the scope to work back to the video detector. Since this trouble can arise after the sync separator, also work forward to the sweep circuits.

Compression can be caused by overloading in any stage from the front end right up to the video amplifier. Thus, a defect in agc or a defective tube can produce this condition. The trouble can also be due to improper if alignment.

Time-saver

Adjust the vertical hold control to roll the picture to see the vertical blanking bar. The photo in Fig. 604 shows normal vertical blanking while Fig. 605 shows evidence of sync compression. This test indicates that the compression occurs in some stage from the video amplifier back to the front end.

The gray area running across the center of the picture represents vertical blanking time. The very dark rectangular area near the center consists of vertical sync pulses, while the narrower but longer black rectangle represents the equalizing pulses.

Sync compression usually affects both horizontal and vertical sync pulses, but may not result in tearing because of the presence of horizontal afc. In any event, it is much easier to check compression by upsetting the vertical hold control.

If the horizontal sync pulses are completely lost, the picture will tear too strongly to permit the use of the picture or test pattern.

Pentagrid sync separator

In most receivers a triode is used as the sync separator, but a

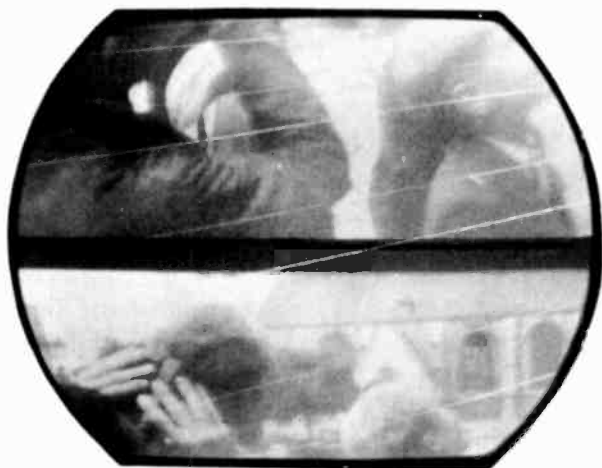

Fig. 604. Adjustment of brightness and vertical hold allows the black sync pulses to be visible on the dark gray background of the blanking pedestal.

pentagrid tube is employed in some sets. A typical separator is shown in Fig. 606. Two signals are fed into the clipper; one from the video amplifier and one from the video detector. The input signals are unequal in amplitude and are also out of phase.

This circuit has several advantages. Because the two signals are phase-inverted, noise pulses also have opposite phase and cancel. Thus the tube functions as a combined noise clipper and sync separator. The pentode also gives much more gain than a triode, so the stage could be called a noise clipper, sync separator and sync amplifier.

Troubleshooting a circuit of this type is much like that described for the triode, the only difference being that the scope and low-capacitance probe is a necessity to trace the composite video signal back to the detector and to the video amplifier. The tube is biased in the same way as the triode. Bias voltages are checked in the same manner. In addition to the usual voltage checks, the screen grid of this tube is subject to the common ail-

ments of multi-grid tubes. To check its operation, put a vtvm across the screen dropping resistor to measure the voltage drop. If there is no drop in voltage across this resistor, the screen is not drawing current; the tube may be defective. Should the resistor open, the voltage across it would be high — approximately B-plus. A shorted screen bypass capacitor will give a similar reading, but the screen resistor should get extremely warm. Measuring from ground, an open screen resistor or a shorted capacitor would give a very low reading while a tube with an open screen grid

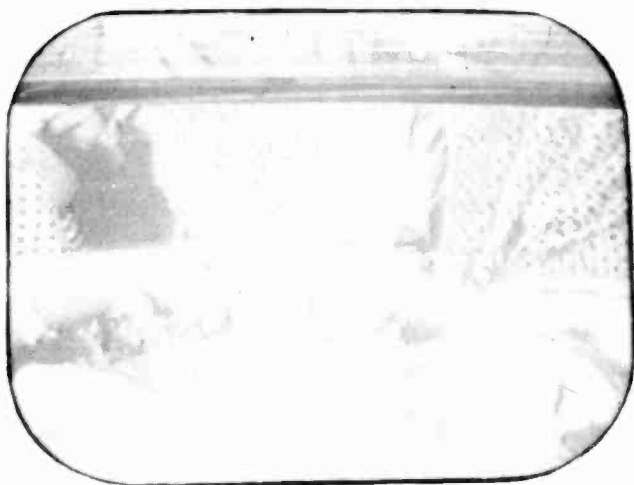

Fig. 605. Color contrast between pedestal and pulses is not as great with sync-pulse compression. The sync pulses are not visible on the blanking bar when the picture is properly adjusted.

or open cathode would have approximately B-plus voltage, or equal voltages at both ends of the resistor.

In some receivers, the output of the sync separator is fed directly into differentiating and integrating networks (these separate the vertical and horizontal sync pulses). However, this very easy arrangement is not always followed. In some older receivers where the composite video signal is taken off the detector, a sync amplifier tube precedes the sync separator. Where the sync takeoff is from the video amplifier, two sync tubes can be used, one acting as the sync separator and the other either as a sync clipper or as a sync amplifier.

A typical two-tube separator circuit is shown in Fig. 607. The second tube, V2, has several advantages. The pulses are clipped

and amplified and the tube can be operated to remove noise pulses that come through. Both tubes can be regarded as sync separators and serviced in the same way. Dc voltage checks can be made on V1 and V2 in the same manner as described earlier for the single sync separator. If the picture shows loss of sync, you can start at the control grid of V2 and work your way back, through the network (R3, R2, R1) to the plate of the video amplifier, using a scope.

Resistors R2 and R3 serve to decouple the control grid of the sync separator from the video amplifier. This network acts as a voltage divider. The grid of the separator should get a signal

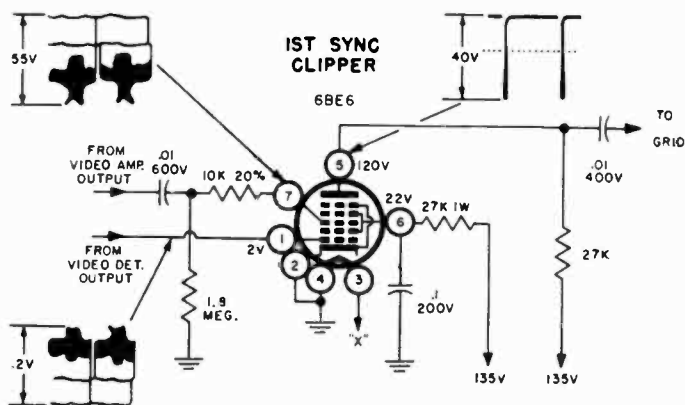

Fig. 606. Typical waveforms found in pentagrid sync clipper and noise inverter.

that is sufficiently strong, but at the same time not reduce the video output to the point where the picture tube is deprived of its input signal. Thus, if the picture is quite strong but does not seem to hold sync, then it is possible that R2 and R3 have changed in value. Use calibrated scope and a manufacturer's schematic to check this.

The capacitors C1 and C2 in conjunction with the resistors (R2, R3), help the pulses maintain sharp edges. The values selected by the manufacturer should be used. Sometimes this circuit, as well as other sections in the sync stage, are in the form of a printed circuit.

In the circuit of Fig. 607, the first tube does the work of separating the pulses from the composite video signal, hence it is properly

called the sync separator. The second tube works very much like a limiter and is properly regarded as a sync clipper. Note that V2 has a slightly positive voltage on its control grid. The tube works near the saturation point or upper bend of its characteristic curve. The only signal that can produce any output is one that can bias the tube negatively. Any video signal that does get through to this tube does not have enough strength to pull the tube out of saturation. The only signal that can do this is the

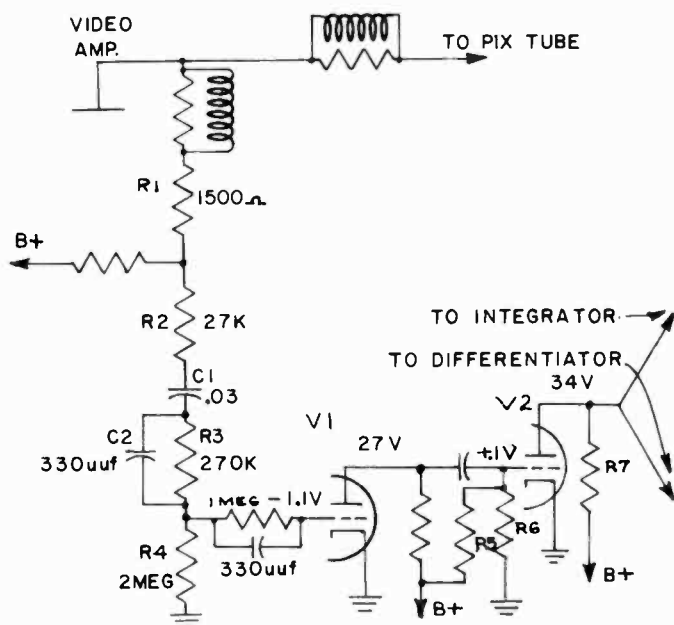

Fig. 607. A twin-triode is often used for a sync amplifier and inverter-separator.

strongly negative sync pulse. Note that V1 and V2 work in opposite ways. V1 works at or near cutoff, V2 at saturation.

To check V2 quickly, connect a vtvm to its plate. In the absence of a signal (turn the tuning control off channel), the plate voltage must be low. Check R5 and R6. They act as a voltage divider for the input to V2. If the voltage on the plate of V2 is very low and R7 seems unusually hot, remove the tube and measure the voltage across R6. If the bias voltage is much above 0.1 volt positive, V2 may burn out.

Noise

Noise picked up and amplified by the receiver can appear as streaks in the picture and can cause sync instability. Many receivers do not have noise-limiting circuits and depend upon the limiting action of the sync separator and amplifier to cut down the amplitude of any noise pulses. However, some receivers use noise-inverter circuits (Fig. 608) to eliminate noise pulses. The

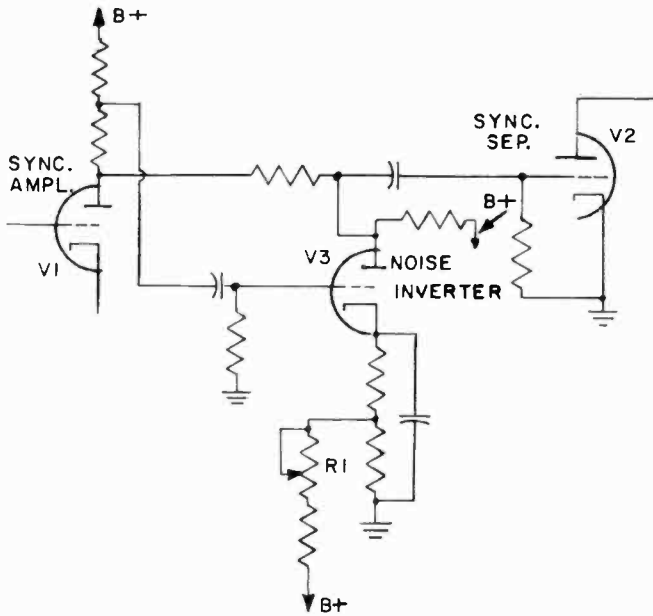

Fig. 608. Sync circuit including a noise inverter.

composite video signal is fed into V1 and is amplified. The amplified output of V1 is injected into V3 and also into the sync-separator tube. V3 has a heavy positive bias on its cathode. The tube can not conduct except when the control grid receives a strong positive signal.

The output of V1 is an amplified composite video signal. Normally, this signal is not strong enough to bring V3 out of cutoff and so V3 does not operate. However, if a noise pulse comes through that has an amplitude greater than that of the sync pulses, it causes V3 to function. The output of V3 consists only of the noise pulse, amplified and inverted. This noise voltage is now fed into V2 with the composite video signal from the

plate of V1. However, the noise voltage from the plate of V3 is out of phase with that from the plate of V1, and the two noise voltages cancel.

This circuit can produce a number of troubles. If, for some reason, the positive voltage on the cathode of V3 should be reduced, the noise inverter amplifies the sync pulses in addition to the noise. These pulses, fed into V2, reduce the sync pulse input to that tube, causing loss of sync.

Resistor R1 is referred to as a fringe compensator or picture stabilizer control. It varies the bias of the noise inverter. If R1 is improperly set, either the noise inverter will not operate on noise pulses or else it will work at all times, serving to reduce sync input to the sync separator. If the receiver has a noise inverter and the complaint is poor sync, adjust this control. It may require some small adjustment due to the aging of V3 or because the receiver has been moved to a new location. Do not overlook the possibility that the owner of the receiver may have tampered with the control.

Check this circuit by connecting a scope between the control grid of V2 and ground. Tune in a station and observe the composite video signal input to V2. Rotate R1 until the sync pulses start becoming smaller. Back off the control and observe the strength of the pulses. Now transfer the probe to the plate of V1. The composite video signal at this point should have approximately the same strength as that at the grid of V2. If not, work back and forth between the plate of V1 and the control grid of V2, adjusting R1, until you can see no difference when you move the probe tip from one point to the other.

Poor horizontal sync

When the amplitude of the composite video signal fed into the sync separator is too great, some of the video component rides through with the sync signals (Fig 609). The result is a sort of horizontal shimmy of all or part of the picture. To check, remove the transmission-line leads but hold them close to the antenna terminal board to couple some signal into the receiver. If the trouble is eliminated, then excessive video is getting into the sync separator. Trouble may exist in the agc circuit, permitting the rf and if video amplifiers to work at too high gain. Check the voltage across the video detector diode load resistor with the receiver tuned to a typical channel. If the voltage is too high, check the agc voltage.

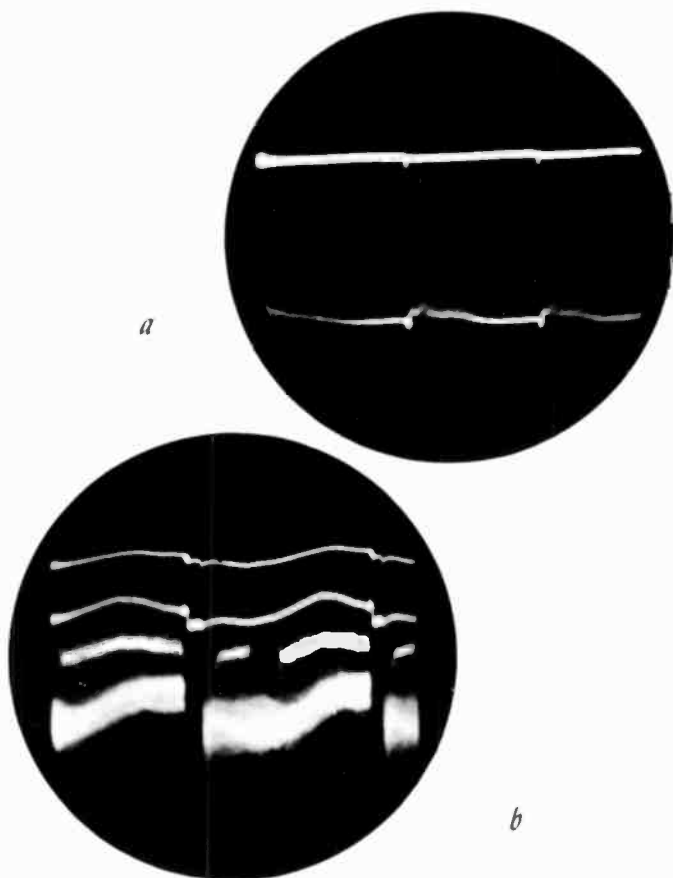

Fig. 609. Normal waveform (A) as it appears at the plate of the first sync clipper. Video signal presence in waveform (B) indicates improper operation.

Some temporary changes can be made to eliminate this trouble, but these are not always satisfactory. For example, using a weaker than normal rf or video if amplifier tube, or connecting an attenuator pad between the transmission line and the antenna terminal board may help. The difficulty with these techniques is that they aren't cures and result in callbacks.

Other causes for poor horizontal sync

It is entirely possible for poor sync to result from a defect outside of the sync circuits. For example, a defective video ampli-

fier (if the sync is taken off after the video amplifier tube) or a poor video detector (crystal) can be responsible. If substituting a new video amplifier tube does not help, try substituting a new crystal detector (particularly if the diode resistor shows lower than normal signal voltage).

Some receivers use stacked tubes — that is, tubes connected in series and acting as a voltage divider. If sync tubes are stacked with other tubes in the TV set, a defect in these other tubes can cause poor sync. Generally, some other trouble will be associated with the condition of unstable or poor sync. For example, if the audio output tube is stacked with one of the sync tubes, the trouble might be weak or missing sound accompanied by poor picture sync. It is always best to consult a schematic diagram as part of your servicing technique.

Trouble that arises in tubes that are stacked can produce poor sync even if the tubes are not in the sync circuits. If the audio output tube is stacked with a group of video if tubes, it can affect sync stability.

Misleading symptoms

Sometimes a picture will remain locked in horizontally but will roll. The temptation here is to jump to the conclusion that there is some defect in the vertical circuits only or in circuits handling vertical sync pulses only. However, this condition can result from a defect in a tube or circuit handling *both* horizontal and vertical sync pulses. The reason for this lies in the greater stability of the horizontal sweep system, since horizontal afc fights to maintain stability. The vertical system has no such circuit, hence is more subject to tube and circuit faults.

Tube troubles

Because sync separators and amplifiers have a grounded cathode, heater-to-cathode leakage isn't troublesome. However, a weak sync separator or amplifier can cause critical sync, particularly rolling (vertical instability). Try substituting new tubes or interchanging tubes of the same type in the receiver.

When the picture appears normal, but loss of sync is evident, you can be fairly certain that the trouble exists somewhere between the video amplifier plate and the output of the sync separator-amplifier circuit.

If the picture appears washed out and sync is critical, then the difficulty is in the video amplifier or in one of the stages that precedes it. Should the picture have streaks in it and the sync is

critical, then the trouble is due to noise pickup and precedes the video amplifier.

Sometimes the trouble exists at the TV station. Tune in another channel. If critical sync appears on two or more channels, then the trouble is in the receiver. A broken antenna lead-in may sometimes affect one channel more than the others.

It is important to make sure that the trouble affects both vertical and horizontal sync, since this narrows the search considerably. Tune in on a strong station and rotate both vertical and horizontal hold controls. (Generally, you need more rotation of the horizontal hold control to throw the picture out of sync.) If both controls are touchy, then the trouble is between the plate of the video amplifier and the output of the sync amplifier. If the picture stays locked in horizontal sync for most of the rotation of the horizontal hold control or in vertical sync for most of the rotation of the vertical hold control, then the trouble is not in the sync circuits described in this chapter.

Overcontrast

When the contrast control is located in the cathode circuit of the video amplifier (in some sets it is in the plate circuit), it is possible to produce a condition of excessive picture contrast if the control is advanced too far. Some people seem to prefer such a picture, but too high a contrast control setting can feed an excessive composite signal into the sync separator. The result is a picture which shakes in whole or in part. If backing off the contrast control improves the sync but gives a weak picture — check the picture tube.

If the picture seems normal but sync is critical, check the setting of the contrast control. If, to get a good picture, the contrast control must be set at the maximum end of its range, it is possible that the sync separator is getting an insufficient amount of composite video signal. Loss of gain is usually caused by a weak video amplifier tube.

Low voltage

Although sync clipper and amplifier stages work with low levels of B-plus, a drop in B-voltage can cause sync instability but may not affect the picture. When B-plus is lowered to the rf amplifier and video if amplifier stages, the gain is reduced but the agc acts to increase the gain. As a result, the picture tube gets its full video signal and so does the sync separator. But the sync separator with reduced plate voltage may cause excessive limiting and sync

clipping. The result is loss of sync or unstable sync. Check the voltage output of the low-voltage supply. The trouble can very well be due to a low-voltage rectifier with reduced emission.

Bending or folding of picture

To work properly, the sync pulses must be fairly sharp. If the edges or sides of the pulses seem indistinct or fuzzy, the trouble is probably due to a leaky capacitor or changed value of resistance between the plate of the video amplifier and the input to the



A voltage calibrator allows more accurate waveform measurements. Properly calibrated, a scope is an excellent peak-to-peak voltmeter. (Electronic Instrument Co., Inc.)

sync separator. This results in bending of the picture, accompanied by critical sync. To check this trouble, start at the input to the sync separator and examine the waveform, working your way back to the plate of the video amplifier with the low-capacitance probe of the scope. If the waveform seems sharp on one side of a resistor or capacitor but fuzzy on the other, the component should be replaced.

Jitter

Keep the leads of the flyback transformer and the deflection yoke away from sync circuits. A rapid shimmy in the picture, present after servicing work has been done, can be due to lead dress that has been disturbed.

Horizontal bending

Tearing of the picture means that there is a complete loss of horizontal sync. In a condition of tearing, there is nothing wrong

with the picture itself. Its horizontal sweep frequency is just completely out of control.

There is a form of distortion in a picture that resembles tearing but which is not. This distortion has a variety of names all based upon the appearance of the picture itself. It is called picture hook, picture bending, horizontal pulling, horizontal bending, S-distortion, snaking. Vertical components of the picture are more or less severely bent.

This condition can be caused by hum modulation in the front end or the video if stages. This is likely to be the case if the snaking is accompanied by symptoms of hum in the picture.

Overloading of video if tubes will also cause picture bending. This condition can be produced in strong-signal areas by receivers having a high-gain front end and a high-gain antenna. A slight reduction in agc effectiveness can quickly result in an overload condition. An attenuator between the antenna transmission line and the receiver will help. Check the agc control since it may need to be reset. Try substituting a new agc keyer tube.

Under the conditions just described, the picture may not bend but lines may be torn out of the top of the picture. Try the same remedies.

Weak sync

Since the sync pulses accompany picture and sound through the front end, picture if and detector stages, and usually through the video amplifier as well, a defect in these stages can affect picture, sound and sync. However, if the sound comes through strong and if the picture strength seems good (even though the picture may be completely out of sync), then you can consider the trouble confined to the sync circuits.

Your next step is to determine in which part of the sync circuits the problem exists. If the picture rolls vertically but remains in horizontal sync, then the trouble usually exists in circuits that handle vertical pulses only. Similarly, if the picture does not roll but horizontal sync is weak or critical, then the fault lies in those circuits that handle the horizontal sync but not the vertical sync pulses. (Remember horizontal sync may be more stable than vertical sync because of horizontal afc.)

When the defect is localized to the sync separator stage (or stages), the problem is not completely solved. Localization of the trouble is but the first step. Sync-separator circuits are often arranged in a somewhat unorthodox fashion as shown in the cir-

circuit diagram of Fig. 610. V1 is a conventional triode but the arrangement of V2 is rather unusual. The output of V1 is directly coupled to the cathode of V2 (there is no coupling capacitor between these two stages). The bias of V2 can be measured only by checking between control grid and cathode of that tube. The bias for V2 is developed across R2. But R2 is part of the voltage-divider network for V1. The operation of V2 is directly dependent upon the functioning of V1. If you suspect tube trouble in a

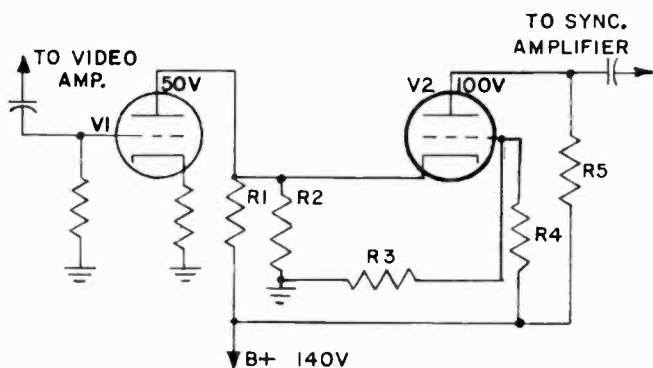

Fig. 610. Direct-coupled sync separator has both cathode and grid at a high positive voltage.

circuit of this type, replace both tubes (one at a time) to see if sync operation can be improved. Since both V1 and V2 are being used as sync separators, a defect in V1 will cause improper operation of V2. But since the sync pulses must pass through both tubes, the effect on the pulses is that much greater. It is best to use circuit diagrams supplied by manufacturers as part of your servicing routine.

In a circuit such as that shown in Fig. 610, changes in component values (R1, R2, R3, and R4 or R5) can cause both tubes (V1 and V2) to work improperly.

A word of caution: Some technicians treat plate and screen grid points with care since they expect B-plus voltages. Usually the control grid is not a B-plus point and so they are inclined to be less careful. The control grid of V2 in Fig. 610 is a B-plus point. While the amount of shock voltage isn't very high, the involuntary movement of a hand or probe caused by unexpected B-plus voltage can cause damage.

Trouble analysis is just about your best servicing tool. Recognizing a symptom as it appears on the screen of a TV set, is the

important first step. Servicing is a process of elimination. Two circuits need not be directly connected for one to affect the other. There is no magic formula for fixing sets. The next best thing is to list mentally possible symptoms and locate the trouble by elimination.

Sync troubles and the video amplifier

The video amplifier is to the sync separator what the antenna is to the rf amplifier in the front end — that is, a signal source. Sync troubles can arise in the video amplifier and sync troubles can exist outside the sync circuits.

Since sync pulses are the maximum amplitude of the signal, limiting action can affect sync but not necessarily video. For example, sync limiting will exist in the video amplifier if for any reason the tube must operate in a nonlinear region of its characteristic curve. This can happen when the plate voltage on the video amplifier is lower than normal, if there is insufficient screen voltage, if the bias voltage is too low or if the signal input is excessive. Sometimes a combination of these factors can exist to produce sync troubles.

Since strong signals are the ones most affected by video amplifier voltage troubles (that is, troubles that force the video amplifier tube to act as a limiter), check by detaching the transmission line from the antenna terminal board. Hold the antenna leads close to the board so there is some capacitive coupling. If this test restores sync, then check on the operating voltages of the video amplifier. A slightly gassy video amplifier tube can help produce the horizontal bar are the blanking pulses.

To check easily on how the video amplifier is handling the sync signals, adjust the vertical hold so that the horizontal black bar (vertical blanking pulse) is seen. Now adjust the contrast and brightness controls so that the bar has varying shades of black and gray. Do this carefully. A very black section across the top of the horizontal bar will be seen, while the rest of the bar will appear less black. The very black section consists of the vertical equalizing and sync pulses. The less black (or grayish) portion of the horizontal bar is the blanking pulses.

When the sync and equalizing pulses produce a very dark area across the top of the blanking bar, then you can assume that sync is good as far as the output of the video amplifier and that sync troubles are after this point. When the area across the top of the blanking bar can hardly be distinguished from the rest of the

horizontal bar, there is sync compression. With a receiver known to be in good working condition, tune in on a strong station and perform the test just described. Get familiar with the appearance of the sync and equalizing pulses under normal conditions. Repeat the test with a very weak station (but with the picture holding in sync) and once again observe the blanking bar. Get to know the appearance of the bar under all conditions.

Front-end trouble

Although this seems a remote possibility when considering sync troubles, there are instances in which a front-end defect can cause rolling (horizontal a/c action generally prevents tearing). If the picture rolls, try to adjust the vertical hold control so the picture moves slowly. Examine the picture carefully. If you find traces of snow, you have an indication of trouble in the front end. The rf amplifier in the front end may be the cause.

Switching tubes

If sync seems a bit touchy but you do not have a replacement handy for a substitution test, try switching the sync separator or amplifier tubes with others in the sweep system (or other circuits) where these tubes are identical types. A tube that does not perform well in one circuit may work very well in another.

Sync buzz

Many technicians confuse buzz and hum and quite frequently refer to all unusual sounds as hum. Hum in a television receiver can have two frequencies — 60 or 120 cycles. Hum has a characteristic sound — it is smooth, not rough.

Sync buzz sounds very rough in comparison. A buzz in the sound can be a symptom of sync compression. If vertical sync is critical and you hear buzz, check for evidence of sync compression. Sync compression is a sign of overloading so turn the channel selector to a weak station. If the picture locks in and buzz disappears but returns when the selector is turned to a strong station, there is sync compression. The agc threshold control may be misadjusted. One of the tubes between the front end and the picture tube may be slightly gassy. There may be a defect in the agc line so that lower than normal agc voltage is being delivered.

Check for sync compression by using a scope (also refer to the use of the scope described earlier). When testing circuits prior to the video detector, use a detector probe to see the signal. Points to check are the input (control grid) and output (plate) of each

tube preceding the video detector. The crystal probe is not needed when testing at or after the detector.

When using a probe, especially in rf and if sections of the TV receiver, some technicians forget that they are working in high-frequency circuits. The ground lead of the probe is often connected to any convenient ground point, usually the chassis. The ground return of the probe should be as close as possible to the point being tested. The ground lead of the probe should not be allowed to form a loop. Quite often, distorted waveforms will be seen on the scope as a result of improper use.

Critical sync — engraved effect

If the picture looks engraved (negative effect) and the sync is critical, the trouble is due to overloading. From the appearance

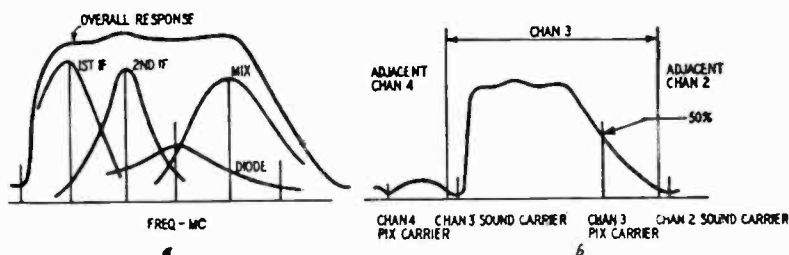

Stagger-tuned if transformer circuits are designed to give the overall response shown in (A). If the 50% point indicated in (B) is not located on the carrier-frequency of the channel improper sync pulse amplitude can cause critical sync.

of the picture on the screen, we know that the trouble is not in the sync circuits, but precedes them. Check the agc system. Reduced agc bias can produce these symptoms.

When overloading is due to tubes, it can be caused by some slight amount of air in the tube (gassy tube) or because of grid emission. In the process of manufacture (or in use), some electron-emitting material (cathode material) may be deposited on the control grid. Then radiated heat from the cathode causes electron emission from the control grid. This grid-current flows to the plate and then back through the grid return resistor, producing a grid-to-cathode voltage in opposition to the regular bias. The effect is to reduce the bias for that particular tube. Overload can also occur when the grid emission is very small but the grid-return has increased in value.

This type of overloading generally occurs in if stages that are agc controlled and have a resistance return to ground instead of inductance (or in any amplifier stage that has a resistance return

to ground). The higher the value of resistance, the more serious the effect of grid emission is likely to be.

Critical sync in old receivers

Critical sync in many older television sets is not necessarily due to the failure of a single component and is often caused by the deterioration and changed values of parts. Capacitors absorb moisture, become leaky, collect dust and dirt, resistors can change value, etc. In cases of this sort it may be necessary to replace a large number of components — and the customer may never be satisfied.

Unstable sync

A large number of sync problems arise in circuits that control the signal. Any condition that affects the sync signals before they reach the separator means that the separator is not given an opportunity to function properly. This gives rise to sync problems, but troubleshooting must be done in circuits other than sync. Horizontal pulling, jitter, tearing (at top of the picture), distortion of picture, and critical hold controls can often be traced back to some defect in agc circuitry. Examine the blanking bar as described earlier or check the agc bus voltage.

Contrast good, vertical and horizontal sync poor

This is an indication that both signal and sync pulses are good right up to the input of the picture tube but that there is some problem after the sync-takeoff point. Since both vertical and horizontal sync are affected, check between the sync-takeoff point and the point at which the pulses are separated (immediately prior to the differentiating and integrating networks).

Leaky sync coupling capacitors

Resistance-capacitance coupling is used between the two stages of a sync separator. A leaky coupling capacitor here can cause rolling or tearing. To check the capacitor, disconnect the lead of the capacitor going to the control grid of the second sync tube. Connect a vtvm (set to read about 300 volts maximum dc, full scale) between the loose end of the capacitor and the chassis. Short the antenna terminals or rotate the channel selector to an unused channel. If you get no indication on the vtvm, rotate the range selector of the instrument to a lower range. Any continuous positive voltage reading means that the capacitor is leaky.

Use a neon-lamp indicator in place of the vtvm—continuous flashing will indicate a leaky capacitor.

Hum in the sync

Heater-to-cathode leakage in a sync tube isn't necessarily trouble some since these usually work with grounded cathodes. There are some circuits where sync tubes do use cathode resistors, so this problem can arise. However, heater-to-cathode leakage in one of the preceding tubes (such as in the picture if) can cause rolling. Look for evidence of hum as the picture goes out of sync. You can locate the defective tube in one of several ways. Try tube substitution. Ground the cathode of each tube from front end to video amplifier (do this quickly so as not to damage the tube).

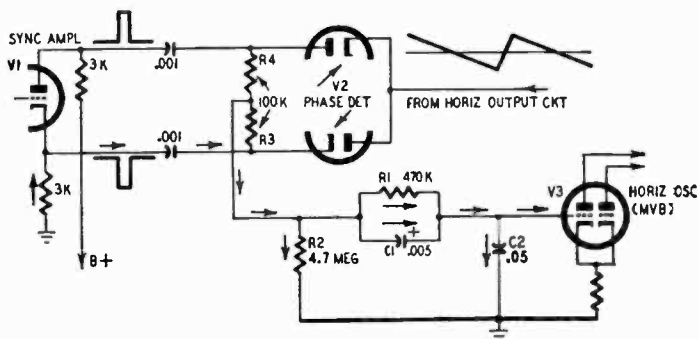

Sync pulses fed to the phase detector from the amplifier must be equal or the indicated charge path for C2 will apply a control voltage to the grid of V3, even though the oscillator is the proper frequency.

If, by grounding the cathode of a particular tube, the trouble is eliminated, that tube should be replaced.

Ghosts

Severe ghosts can result in critical sync. If the ghost is sufficiently displaced from the original picture, some signal-voltage cancellation can occur and as a result the sync pulses are reduced in strength. If sync action is good on all stations (except those showing ghosts), try to improve the situation by proper impedance matching or more careful orientation of the antenna. In some cases (apartment houses) where outdoor antennas are not permitted, try placing the indoor antenna at different spots in the room.

Excessive heat

In some receivers, excessive heat buildup can cause loss of sync. Remove the back of the receiver. If the line cord is fastened to the back panel of the set, remove it by drilling out the rivets that

hold it in place. If the set is mounted flush against a wall, move it away a few inches.

Split picture

Sometimes the picture will seem to want to lock in place with the blanking bar dividing the picture into two sections. This can be caused by a gassy sync separator or amplifier tube. Also check resistors and capacitors in the sync stages. Do not confuse this condition with a double picture (caused by vertical oscillator working at 30 cycles per second).

Distorted sound, loss of sync

A defect in some stage not usually associated with the picture or sync circuits can cause loss of sync. In such instances where the circuits have no relationship to each other, look for a common factor. The only common relationship between sound and sync is in the B-plus line. An audio defect can lower B-plus to the point where sync becomes affected. Whenever there are sync problems, but picture and sync circuits seem to be in good working order, examine the circuit diagram to see if there are any unusual circuit arrangements (such as stacked tubes).

In series-string receivers, check the ac voltage across the filaments of the sync tubes and on those tubes through which the composite video signal passes.

Design changes

A set may have critical sync due to original set design. Quite often faults may not appear until the receiver has been in active service for a time. If voltage and waveform tests indicate normal operation, it is sometimes helpful to consult manufacturer's notes. Quite often, simple design changes, such as increasing or decreasing the value of a resistor or capacitor, is needed.

Lead dress

A TV receiver has many high amplitude pulse voltages. The voltage on the plate of the agc keyer tube is a typical example. Keep this lead away from the sync separator input. Also make sure that the filament lead is kept away from the control grid of the sync separator. Hum or pulse pickup by the sync separator can result in loss of sync.

A jumpy picture can be produced through the coupling of the audio signal into the sync input. This is particularly true of leads of the audio output tube since the currents in this tube

are much greater than in preceding audio tubes (hence larger magnetic fields).

Replacing components

Many technicians assume that because a component is new that it must be good. In most cases the assumption is a good one, but even a brand-new part (or tube) can be defective. It might save time to run a quick ohmmeter check on new resistors and to test capacitors before using them. Check capacitors for capacitance and leakage. If electrolytics have been on the shelf for a while, it is best to re-form them. (Apply a lower than normal dc voltage to the capacitor and then gradually bring the voltage up to the amount that will be across it in the receiver).

Remember also that the capacitors in sync circuits pass two frequencies that are very widely separated — 60 and 15,750 cycles. This means that capacitors will offer much lower reactance to the higher-frequency horizontal sync pulses. These pulses will often get through while the lower-frequency vertical sync pulses are blocked by some component defect. Add to this the fact that horizontal afc acts to keep the picture in horizontal sync while the vertical sweep has no such protection and you will appreciate why it is possible for a picture to roll and yet for horizontal sync to seem good — but with some defective capacitor in the sync circuits.

Picture stabilizer — fringe-lock adjustment

Some receivers use a variable resistance between the video amplifier output and the input to the sync separator. The setting of this pot determines the amount of signal input to the sync separator and helps make sync action somewhat independent of the setting of the contrast control. Adjust the pot so that rotation of the vertical hold control makes the picture seem to “snap” into place.

In some receivers this control is in the grid circuit of the sync separator. The action of the pot is the same as the one located between the video amplifier and the sync tube — that is, it controls the amount of input signal to the sync separator.

index

A

Adapter, Tube-Test	1-31
Adapters, Test Point	1-31
AGC:	
Basic Circuit	1-81
Battery Box	1-84
Bias Supply	1-85, 1-93
Circuit, Delayed	1-82
Circuit, Improved	1-101
Clamp	1-90
Defects	1-92
Delay for Tuner	1-90
Diode, Separate	1-83
Excessive Bias	1-89
for the Mixer Tube	1-29
Keyed	1-87
R-C Filter	1-101
Tubes, Multipurpose	1-99
Types	1-81
Voltage	1-50, 1-79
Voltage Distribution	1-80
Voltage Substitution	1-84
Winding on Horizontal Output Transformer	1-103
Winding on Width Coil	1-104
Airplane Flutter	1-98
Alignment:	
and AGC	1-86
Fringe Area	1-24
IF	1-42
of Front End	1-20
of Tuner	1-20
Amplifier, IF	1-35
Amplifier, Video	1-107
Antenna:	
Attenuator Pads	1-8, 1-9
for Cascode Tuner	1-8
for Pentode Tuner	1-8
One, for Two Receivers	1-11
Signal Area, Strong	1-2
Signal Area, Weak	1-8
Single Rod Balun	1-25
Test, for Dipole	1-11
Test for Folded Dipole	1-11
Tips on,	1-10
Antennas	1-24
Attenuator Pads, Antenna	1-8, 1-9
Audio Tube as Voltage Divider	1-52

B

Balancing Device, Transmission Line	1-16
Balun for Single Rod Antenna	1-25
Bar, Black in Picture	1-97
Bar in Picture, Hum	1-72
Bar Signal	1-128, 1-130
Barkhausen Oscillation	1-26
Bars, Sound	1-26, 1-48, 1-118
Battery Box	1-84
Bend in Picture	1-70
Bias, Excessive AGC	1-89
Bias Supply	1-85, 1-93
Black Compression Waveform	1-131
Blurred Picture	1-61
Boosters	1-17
Buzz:	
Cross-Modulation	1-120
Due to Impedance Mismatch	1-13
Sync	1-101, 1-152
Bypass, Filament	1-56

C

Cascode Tuners	1-18
Cathode-Heater Leakage	1-26, 1-38, 1-45, 1-97
Cathode-Heater Short	1-38
Chassis, Hot	1-29
Chassis, Removal	1-28
Circuit:	
AGC, Improved	1-101
AGC, Keyed	1-88
Antenna Balun	1-25

Circuit (Cont.)

Basic AGC	1-81
Delayed AGC	1-82
IF Coupling	1-52
Local Oscillator	1-32
Neutrode Tuner	1-25
Peaking Coils in	1-109
Sound Takeoff	1-74
Stacked B-Plus	1-53
Step Wave Filter	1-130
Vacuum Tube Detector	1-64
Video Detector	1-60
Video Detector Defects	1-75
Video IF	1-42
Circuits, Printed	1-76
Clamp, AGC	1-90
Cleaning Tuner	1-30
Clipper, Sync	1-141
Coil, Width, AGC Winding on	1-104
Coils, Peaking	1-62, 1-113
Coils, Peaking, in Circuit	1-109
Color Burst Signal	1-131
Compression, Sync-Pulse	1-72, 1-139
Contrast:	
Control Troubles	1-113
Delayed	1-45
Excessive	1-97
Insufficient	1-44
Picture, Poor	1-95
Weak	1-44
Control, Contrast, Troubles	1-113
Coupling, IF Amplifier	1-51
Coupling, Types of IF	1-52
Cross-Modulation Buzz	1-120
Crystal Diode Performance	1-67
Curve, Response, IF Amplifier	1-43

D

Decoupling Filter	1-57
Delayed AGC	1-90
Delayed Contrast	1-45
Detector:	
Video	1-59
Video, Circuit	1-60
Video Crystal	1-63
Video, Load Voltage	1-109
Video Semiconductor	1-63
Video Vacuum Tube	1-63, 1-70
Waveform, Video	1-71
Diode:	
Crystal	1-63
Performance	1-67
Semiconductor	1-63, 1-66
Separate AGC	1-83
Symbol, Semiconductor	1-76
Tester	1-100
Vacuum Tube	1-63
Dipole Antenna	1-11
Direct-Coupled Sync Separator	1-150
Distance-Local Switch	1-122
Dots in Picture	1-104

F

Fading Picture	1-54
Filament Bypass	1-56
Filament Tester, Series	1-37
Filter:	
AGC, R-C	1-101
Circuit, Step Wave	1-130
Decoupling	1-57
High-Pass	1-12
Fine Tuning	1-32
Flashes in Picture	1-29
Flicker, Picture	1-98
Flutter, Airplane	1-98
Folded Dipole Antenna	1-11
Frequency-Burst Signal	1-126, 1-129
Frequency, Sweep	1-131
Fringe:	
Area IF Realignment	1-24
Area Problems	1-23

Fringe (Cont.)	
Area Sync Action	1-24
Lock	1-157
Front End:	
Noisy	1-22
Realignment	1-20
Test Points	1-21
G	
Gassy Tubes	1-38
Ghost Eliminator	1-13
Ghosts	1-155
Ghosts due to Impedance Mismatch	1-13
Ghosts, Lines Similar to	1-55
Gimmick	1-76
Grey Scale	1-130
Grounding Tuner	1-31
H	
Heat Sink, Semiconductor	1-65
Heater-Cathode Leakage	1-26, 1-38, 1-48, 1-97
Heater-Cathode Short	1-38
High-Frequency Response, Poor	1-49
High-Pass Filter	1-12
Hold, Horizontal, Critical	1-96
Hook, Horizontal Picture	1-70
Horizontal:	
Hold, Critical	1-96
Output transformer AGC Winding ..	1-103
Picture Hook	1-70
Hot Chassis	1-29
Hum:	1-116
Bar in Picture	1-72
In Sync	1-155
60 Cycle	1-45
I	
IF:	
Alignment	1-24
Amplifier	1-35
Amplifier Coupling	1-51
Amplifier Response Curve	1-43
Amplifier Voltages	1-50
Realignment, Fringe Area	1-24
Response Curve	1-153
Transformer, Checking Video	1-56
Transformer, Replacing Video	1-56
Transformer, Video	1-47
Tube Troubles	1-36
Ignition Noise Pick-Up	1-12
Ignition Noise Suppressor	1-13
Impedance Match, Transmission Line ..	1-13
Impedance Matching Device	1-13
Intercarrier Sound	1-47
Intermittent Picture	1-45
Isolation Transformer	1-28
J	
Jitter	1-20
Jumping Picture	1-104
K	
Keyed AGC	1-87
Keyer Tube	1-87
Keyer Voltages	1-105
L	
Lead:	
Dress	1-46, 1-156
-in Impedance Match	1-13
-in Installation	1-11
-in Suggestions	1-11
-in Test for Dipole	1-11
-in Test for Folded Dipole	1-11
Leakage, Heater-Cathode	1-38, 1-45
Line Voltage	1-23
Lines, Similar to Ghosts	1-56
Local-Distance Switch	1-122
Local Oscillator Tube Replacing	1-18
M	
Matching Device, Impedance	1-13
Matching Stub	1-15
Microphonic Tube	1-26, 1-38

Microphonics	1-19
Misalignment	1-42
Mismatch, Impedance, Buzz due to	1-13
Mismatch, Impedance, Ghosts due to ..	1-13
Mixer, Tube AGC for	1-29

N

Negative Picture	1-94
Neutrode Tuner	1-25
Noise Inverter	1-143
Noise, Receiver Tube	1-22
Noisy Front End	1-22
Noisy Tuners	1-22

O

Oscillation:	
Barkhausen	1-26
Picture	1-47
Suppressor	1-120
Video	1-47
Oscillator:	
Inoperative	1-30
Local	1-32
Tube, Local, Replacing	1-18
Output, Video Detector	1-69
Overloaded Picture	1-67
Overloading	1-93
Overpeaking	1-116

P

Pads, Antenna Attenuator	1-8, 1-9
Peak-to-Peak Voltages	1-68
Peaking Coils	1-62, 1-113
Peaking Coils in Circuit	1-109
Pentagrid Sync Separator	1-139
Phasing Device, Transmission Line ..	1-16
Pick-Up, Ignition Noise	1-12
Picture:	

and Sound, Loss of	1-19
Blurred	1-61
Contrast, Poor	1-95
Detector	1-59
Dots in	1-104
Fades	1-54
Flashes in	1-29
Flicker	1-98
Hook, Horizontal	1-70
Hum Bar in	1-72
Intermittent	1-45
Jumping	1-104
Negative	1-94
Oscillation	1-47
Overloaded	1-67
Pullout	1-127
Smear	1-19, 1-71, 1-114
Sound Bars in	1-118
Stabilizer	1-157
Streaks in	1-104
Washed Out	1-95
Wiggling	1-54
Poor High-Frequency Response	1-49
Positive Feedback, Video	1-115
Power Tube as Voltage Divider	1-52
Printed Circuits	1-76
Pulse:	
Compression, Sync	1-72, 1-138
Voltage, Keyer	1-105
White Reference	1-124, 1-129

R

R-C Filter, AGC	1-101
Realignment, Fringe Area IF	1-24
Realignment, IF	1-42
Regeneration, Video	1-48
Resistor, Screen Dropping	1-121
Response:	
Curve, IF	1-153
Curve, IF Amplifier	1-43
High-Frequency, Poor	1-49
Reversals, Trailing	1-22, 1-43

S

Scope, Using the	1-136
Screen Dropping Resistor	1-121

Semiconductor:			Tube (Cont.)	
Diode	1-66		Pins, Bent	1-39
Diode Performance	1-66		Removal	1-28
Diode Symbol	1-76		Shield	1-39
Separator:			Test-Adapter	1-31
Direct-Coupled Sync	1-150		Troubles, IF	1-36
Pentagrid Sync	1-139		Tubes:	
Sync	1-134		Gassy	1-38
Triode Sync	1-137		Microphonic	1-38
Series-Filament Tester	1-37		Multipurpose	1-99
Shield, Tube	1-39		Weak	1-38
Short, Heater-Cathode	1-38		Tuner:	
Shunt, Thermal	1-65		AGC Delay	1-90
Signal:			Cleaning of	1-30
Bar	1-128, 1-130		Fine	1-32
Color Burst	1-131		Grounding	1-31
Frequency-Burst	1-126, 1-129		Neutrode	1-25
Stair-Step	1-129, 1-130		Noisy	1-22
White Reference	1-124, 1-129		Realignment	1-20
Slow Warm-Up	1-45		Test Points	1-21
Smear, Picture	1-19, 1-71, 1-114		Types	1-33
Snow	1-25, 1-27		Tuners, Cascade	1-18
Snow, Excessive	1-95		Twin-Lead (also see Transmission Line)	1-24
Sound:			V	
and Picture, Loss of	1-19		Vacuum Tube Video Detector	1-70
Bars	1-26, 1-48, 1-118		Video:	
IF Transformer	1-36		Amplifier	1-107
Intercarrier	1-47		Detector	1-59
Trap	1-36, 1-49, 1-119		Detector Circuit	1-60
Stabilizer, Picture	1-157		Detector Load Voltage	1-109
Stair-Step Signal	1-129, 1-130		Detector, Vacuum Tube	1-70
Step Wave Filter Circuit	1-130		Detector Waveform	1-71
Streaks in Picture	1-104		Fades	1-54
Stub, Matching	1-15		IF Circuit	1-41
Suppressor:			IF Transformer	1-47
Ghost	1-13		IF Transformer, Checking	1-56
Ignition Noise	1-13		IF Transformer Replacing	1-56
Oscillation	1-120		Oscillation	1-47
Sweep Frequency	1-131		Positive Feedback	1-48
Switch, Local-Distance	1-122		Regeneration	1-48
Symbol, Semiconductor Diode	1-76		Smear	1-71
Sync:			Voltage:	
Action, Fringe Area	1-24		AGC	1-50, 1-79
Buzz	1-101, 1-152		AGC, Distribution	1-80
Clipper	1-141		AGC Substitution	1-84
Hum in	1-155		Bias Supply	1-85
Noise Inverter	1-143		Distribution, Video	1-108
Pulse Compression	1-72, 1-138		Divider, Audio Tube as	1-52
Separator	1-134		IF Amplifier	1-50
Separator, Direct-Coupled	1-150		Keyer Pulse	1-105
Separator, Pentagrid	1-139		Line	1-23
Separator, Triode	1-137		Peak-to-Peak	1-68
Takeoff	1-122, 1-134		Sync	1-135
Voltages	1-135		Video Detector Load	1-109
Waveforms	1-141		Voltages, IF Amplifier	1-50
T			VTVM	1-95
Takeoff, Sync	1-222, 1-134		W	
Test Point Adapters	1-31		Warm-Up, Slow	1-45
Test Points, Front End	1-21		Washed Out Picture	1-95
Test Points, Tuner	1-21		Waveform:	
Thermal Shunt	1-65		Bar Signal	1-128
Trailing Reversal	1-22, 1-43		Black-White Compression	1-131
Trailing Whites	1-43, 1-72		Colorburst Signal	1-131
Transformer:			Frequency-Burst	1-126
Isolation	1-28		Stair-Step Signal	1-129
Sound IF	1-36		Sync Clipper	1-
Video IF	1-47		Sync Pulse Compression	1-72
Video IF, Checking	1-56		Video Detector	1-71
Video IF, Replacing	1-56		White-Reference Pulse	1-124
Transmission Line:			Waveforms, Sync	1-141
Balancing Device	1-16		Weak:	
Impedance Match	1-13		Contrast	1-44
Installation	1-11		Picture	1-44
Phasing Device	1-16		Tubes	1-38
Test for Dipole	1-11		White Compression Waveform	1-131
Trap, Sound	1-36, 1-49, 1-119		White-Reference Pulse	1-124, 1-129
Triode Sync Separator	1-137		Whites, Trailing	1-43
Tube:			Width Coil, AGC Winding on	1-104
Keyer	1-87		Wiggling Picture	1-54
Microphonic	1-26			
Noise	1-23, 1-25			

PRINTED IN THE UNITED STATES OF AMERICA