

SERVICING TRANSISTOR RADIOS

by Leonard D'Airo



GERNSBACK LIBRARY NO. 76

\$2.90

Gene E Willard

1959

Gene B. Dillard



**SERVICING
TRANSISTOR
RADIOS**

LEONARD D'AIRO

GERNSBACK LIBRARY, INC.
NEW YORK 11, N. Y.

TO MY PARENTS

My mother, for her patience, and
my father for teaching me the mys-
teries and enjoyment of electronics.

First Printing — November, 1958

Second Printing — January, 1959

© 1958 Gernsback Library, Inc.
*All rights reserved under Universal
International, and Pan-American
Copyright Conventions.*

Library of Congress Catalog Card No. 58-13795

contents

chapter

page

1

Transistor fundamentals

7

Semiconductor theory. Crystalline materials. Donor and acceptor impurities. Current flow: holes and electrons. The p-n junction: diode action. Forward and reverse bias. The transistor. Junction transistors. Transistor configurations. Transistor characteristics. Basic parameters. Current amplification. Power gain. Transistor biasing. Bias stabilization. Frequency capabilities. Effects of temperature. Transistor power requirements.

2

The transistor radio

43

Typical transistor radio. The rf amplifier. Selectivity. Feedback components. Neutralizing the rf amplifier. The transistor mixer. Conversion gain. The transistor oscillator and converter. Intermediate-frequency amplifier. The reflex if amplifier. The detector. Automatic gain control. Special agc circuits. The audio amplifier. Class-B power output amplifier. Class-A driver amplifier. Placement of tone controls. Class-A power amplifiers.

3

Servicing techniques

71

Test instruments. Af signal generator. Transformer turns ratio. Capacitor checker. Rf signal generator. Dc vacuum-tube voltmeter. Ac vacuum-tube voltmeter. Ohmmeter. Capacitor decade (substitution box). Resistance decade (substitution box). Substitute speaker. Signal tracer. Transistor power supply. Component substitution. Printed circuits. Printed-circuit repair. Servicing precautions. Protecting and salvaging transistors.

4

Servicing transistor radios

99

Checking suspected defective transistors. Disabling the agc line. Test points in a typical transistor radio. Agc voltages when using n-p-n and p-n-p transistors. Checking for if oscillation. Tracing audio distortion. Troubles in the mixer, converter and local oscillator. Troubles in if amplifier stages. Troubles in the detector. Checking audio stages. Troubleshooting chart. Receiver alignment.

5

Automobile radios

121

Transistor auto radios. Antenna input circuit. Hybrid auto radios. Power supplies. The dc-to-dc converter. Voltage waveforms. Automatic tuning (the search tuner). Signal-seeking circuit. Interference and noise. Sparking. Reducing interference. Generator whine. Static. Installing the auto radio. Service notes. Service chart. Troubles in the audio driver stage. Troubles in audio-output stages. Dc-to-dc converter troubles.

6

Transistor circuits

147

Regenerative receivers. Regenerative receiver faults. Adjustment of the regeneration control. Shortwave receivers. Noisy controls. Hi-fi tuners. Tuner requirements. Tuned-radio-frequency receivers (trf's). Operation of the trf receiver. Inserting an rf gain control. Converters. Servicing the converter. Converters for shortwave and amateur radio. The preselector. Solar power (the sun battery). Transistor kits. Troubleshooting kits.

7

Tests and measurements

167

Equipment required for making transistor tests and measurements. The constant-current power supply. Measuring alpha. Measuring beta. Techniques for measuring input and output resistances. Measuring feedback and transfer resistances. Determining grounded-emitter characteristics. Determining collector-current cutoff and alpha-cutoff frequency. Measuring beta-cutoff frequency. Quick check method. Transistor testers. Alpha-beta conversion chart.

8

Transistor data

179

Listing of the most commonly used transistors and their characteristics. Current gain. Alpha. Beta. Alpha-cutoff frequency. Matched power gain (in db) in the grounded-emitter configuration. Collector voltage. Collector current (in milliamperes). Collector cutoff current (in microamperes). Collector dissipation (in milliwatts). Transistor interchangeability chart. When to substitute transistors. Transistor substitution precautions.

9

Transistor terms

199

Definitions of most of the common terms used in connection with the theory, operation, manufacture and circuitry of transistors.

Index

219

introduction

The first time I serviced a transistor radio I found that my fingers were all thumbs. I knew next to nothing about transistors, let alone transistor radios. But, after working on many makes and types for the past few years, I have found that they are actually simpler to service than their vacuum-tube counterparts. They're really not so different—it's just a matter of learning a few new techniques.

In this book I have tried to put these techniques into the language of the service technician. I have also tried to present a not-so-mysterious view of the mysteries of transistors and transistor radios. I sincerely hope that I have been able to achieve these purposes.

Many companies made generous contributions of their technical experience and know-how. I would like to acknowledge with thanks the cooperation of Bulova Watch Co., Inc., CBS-Hytron, Clevite Transistor Products, Delco Radio Division (General Motors Corp.), DeWald Radio Mfg. Corp., Emerson Radio & Phonograph Corp., General Electric Co., General Transistor Corp., Hoffman Electronics Corp., Industro Transistor Corp., P. R. Mallory & Co., Motorola, Inc., Philco Corp. (Lansdale Tube Co.), Radio Corporation of America, Regency Division I.D.E.A., Inc., Sprague Electric Co., Sylvania Electric Products Inc., Transistor Electronics Co., Transitron Electric Corp., Tung-Sol Electric Co., Universal Transistor Products Corp., Westinghouse Electric Corp., Workman TV, Inc. and Zenith Radio Corp.

I also wish to acknowledge the aid supplied by my good friend Irving Lavender.

LEONARD D'AIRO

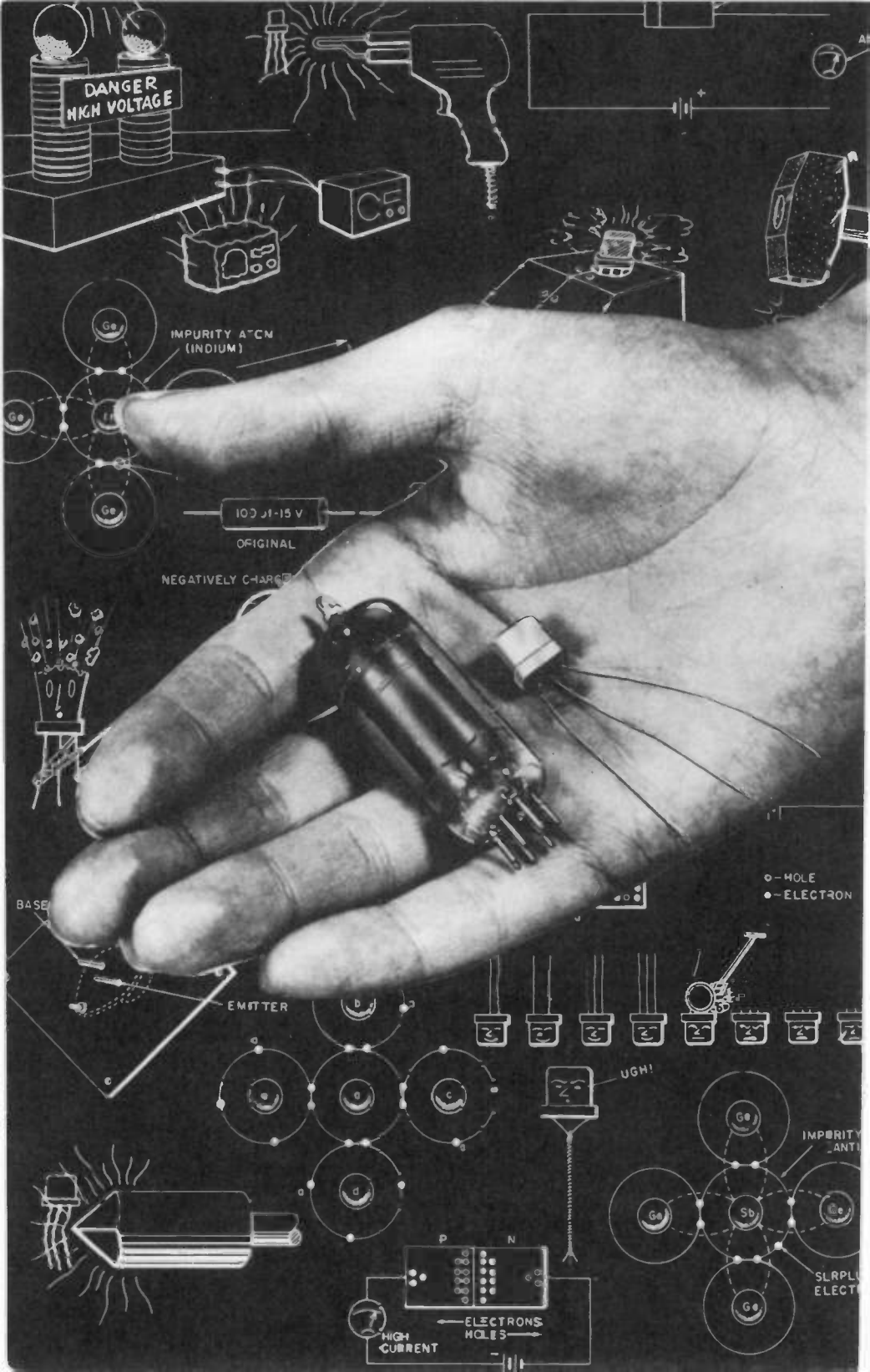

DANGER
HIGH VOLTAGE

IMPURITY ATOM
(INDIUM)

100 J1-15 V

ORIGINAL

NEGATIVELY CHARGED

BASE

EMITTER

○ - HOLE
● - ELECTRON

UGH!

IMPURITY
ANTI

SURPLUS
ELECT

P N

ELECTRONS
HOLES

HIGH
CURRENT

transistor fundamentals

A TRANSISTOR is a current-operated device in which current flow between electrodes is through a solid called a semiconductor. This semiconductor is usually a germanium wafer, although other materials such as silicon are also used.

There are many forms of transistors, and there are many processes involved in producing them. Dominating the field is the junction transistor. Its low noise figure, high gain, high-frequency characteristics and high power-handling capabilities make it especially suited for both audio- and radio-frequency applications. Frequencies beyond 200 mc as oscillators and power outputs in excess of 30 watts as audio amplifiers are typical of these transistors. It is this type that is commonly used in transistor radios.

Semiconductor theory

It is characteristic of the atoms of various elements and compounds to arrange themselves into definite geometric shapes known as crystals. These solids are termed crystalline materials (Fig. 101). For example, table salt, quartz, flowers of sulphur, etc. are crystals. On the other hand, other solids such as rubber, Bakelite, Lucite, glass, etc. are called plastic or amorphous materials because their atoms do not arrange themselves geometrically, but lump together into shapeless masses.

In a crystal (which may weigh many pounds, or be so small that it can be seen only with the aid of a microscope), the faces are flat and are arranged symmetrically with respect to each other, much like the faces of a cut diamond or sapphire. The atoms within the crystal are arranged in an orderly fashion to form what

is known as a lattice. The definition of lattice is “. . . in an orderly fashion” (Fig. 102).

Within this lattice there are certain loosely bound electrons in the outer ring of an atom which align themselves with the loosely bound electrons of a neighboring atom forming a valence bond between them. This bond holds them together to form the lattice (Fig. 103). The loose electrons (valence electrons) do not move beyond their shared neighbors, nor do they move from one end of the lattice to the other. They are held within their bonds, as shown in Fig. 104.

All solids, whether crystalline or plastic, are divided into two major groups called conductors and insulators. A conductor is a

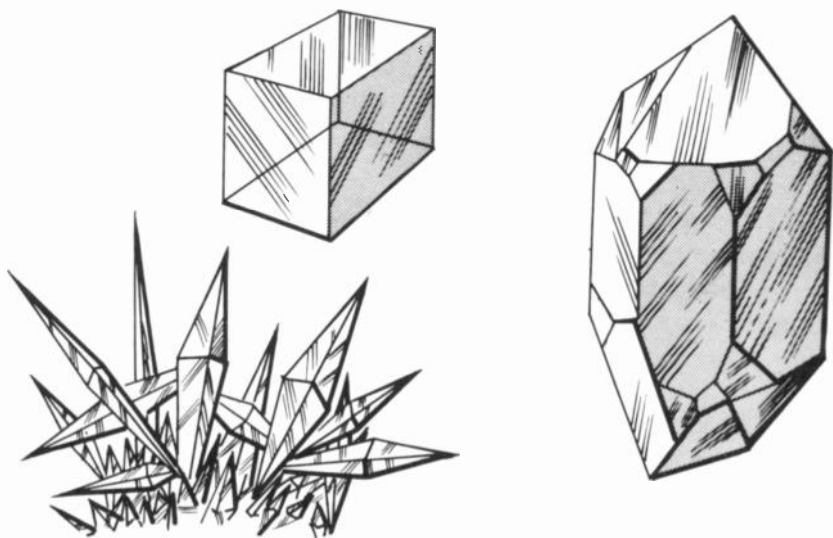

Fig. 101. *Examples of crystal structure.*

solid that permits the easy movement of electrons (conducts electricity), while an insulator does not. But, there is a group of solids that are neither good conductors nor good insulators, since they exhibit some properties of both. These solids form a third group called semiconductors.

Semiconductors are solids that exhibit unique properties. When connected in a circuit in a certain way (Fig. 105), the semiconductor will conduct electricity and act as a low-value resistor. Reversing the connections (polarity) causes the semiconductor to act as a very-high-value resistor (Fig. 106). Selenium, galena, cad-

mium sulphide, silicon, silicon carbide, germanium and copper oxide are some of the semiconductors that have practical uses in modern electronics.

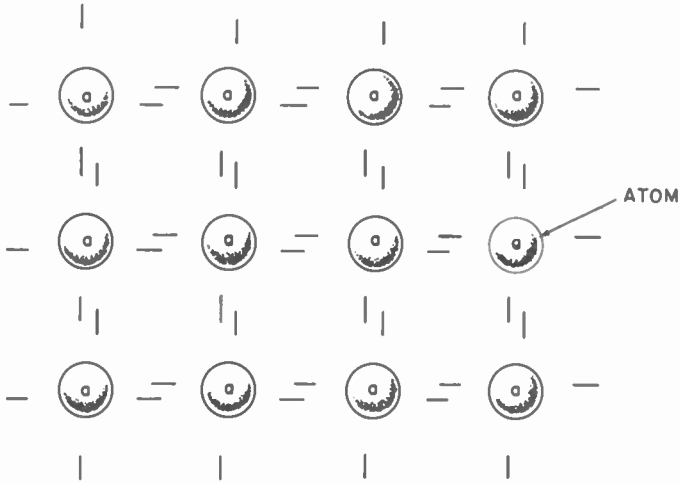

Fig. 102. The arrangement of atoms in a crystal lattice.

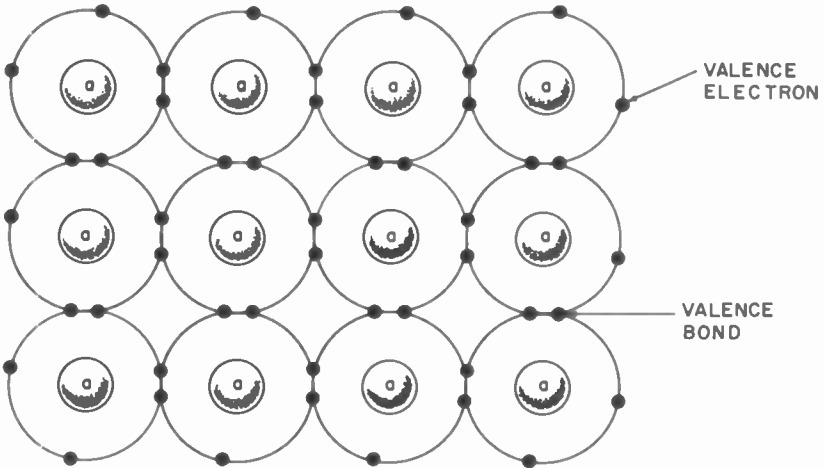

Fig. 103. Diagram showing the valence bond that exists between atoms.

Germanium is the material most often used in transistors. When purified it is usually in the polycrystalline form. That is, a piece of germanium is composed of myriads of individual crystals.

To be used in a transistor germanium must be a monocrystal—the whole piece must be a single crystal, and the atoms must form

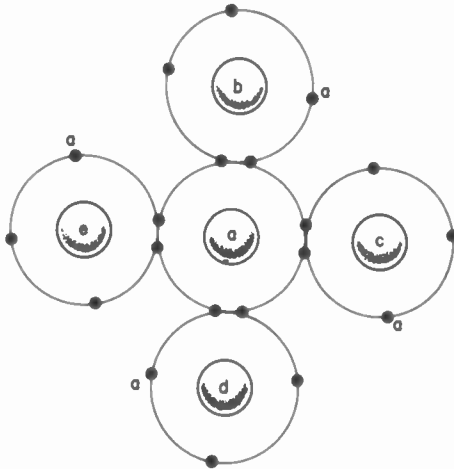

Fig. 104. Movement of valence electrons between neighboring atoms. The dots labeled A represent the electrons that belong to the central atom.

themselves into a single lattice. As shown in Fig. 107, each germanium atom is bonded to four neighboring atoms so that the distance between any two is the same. Each atom of germanium consists of 32 electrons and a nucleus. The nucleus and 28 of

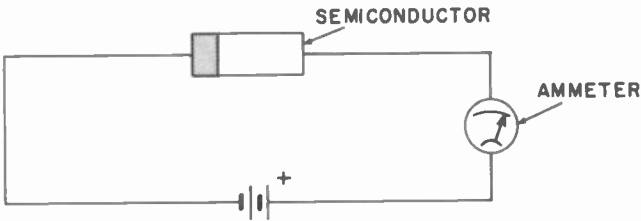

Fig. 105. The semiconductor acts as a low-value resistance.

these electrons form an inert core which has a net charge of +4 in relation to the charge of a single electron. The cores make up the basic mass of the solid but do not contribute to the actual chemical and electrical properties of the solid. The remaining four electrons constitute the bonds between the atoms and are responsible for the electrical and chemical properties of the solid. Two of these electrons, one from each of two neighboring atoms,

cause a binding force to exist between the atoms. This pair of bonds is called a co-valent bond (Fig. 108).

The co-valent bonds are very stable and the electrons are re-

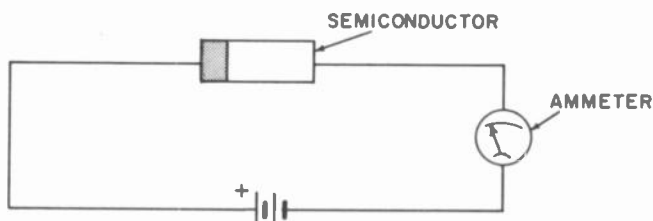

Fig. 106. The semiconductor can act as a high value of resistance.

stricted to their individual bonds. Even though there are millions upon millions of these electrons in a crystal, they are all bound and cannot move from one point in the crystal to another, even under pressure from an electrical field. Therefore, the germa-

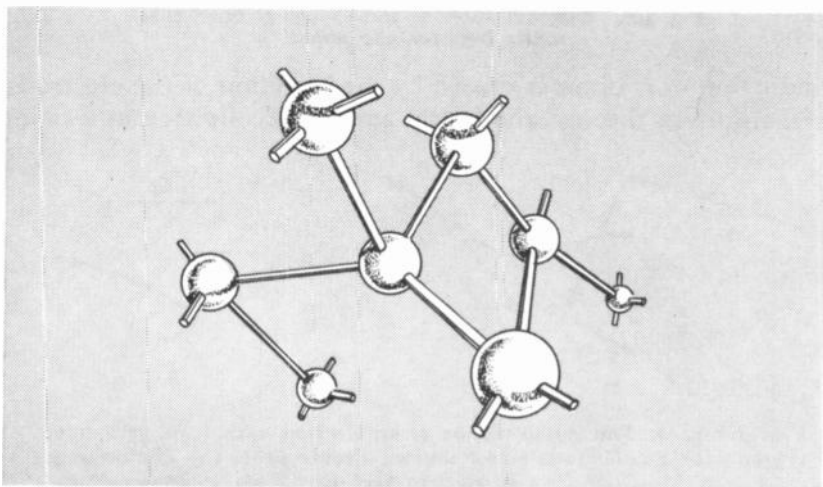

Fig. 107. Symbolic diagram of the structure of a germanium crystal. The spheres represent the atoms, the rods the valence bond between them.

anium acts as an insulator when no impurities are present to disturb or upset the crystal lattice.

Suppose that an electron, or group of electrons, is injected into the pure germanium crystal. Unless the crystal is kept at a temperature of absolute zero, heat causes the lattice to vibrate. This vibration excites or agitates the electrons into motion that causes

them to follow a random zigzag path (Fig. 109). Their motion, however, does not cause the pure germanium to conduct, since the lattice, and the atoms that compose it, are still stable. Whatever

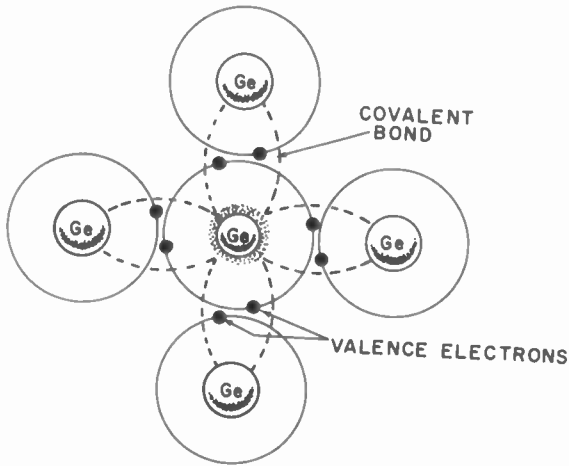
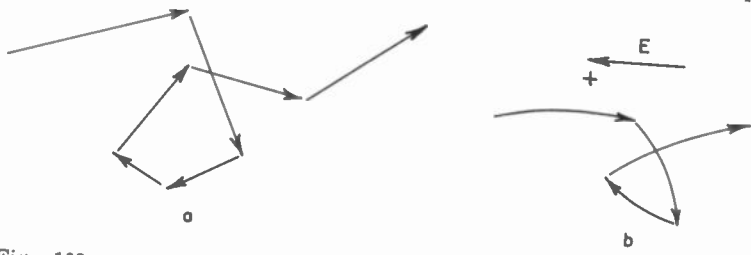

Fig. 108. Diagram showing the co-valent bond that exists between the atoms.

conduction does occur is caused by the injection of the electrons, their diffusion through the lattice and their collection at a point



Figs. 109-a, -b. The zigzag motion of an electron within the germanium crystal. (a) Random motion without an electric field. (b) Motion under an electric field E .

opposite their place of entry. The germanium crystal still does not conduct electricity.

Then, how do we get the germanium to conduct? How do we get it to exhibit transistor action? The answer is simple: by introducing certain impurities into the lattice structure. The introduction of free electrons into the crystal does not affect or disturb the electric field within it. Therefore, to provide electrically charged carriers in the crystal and to be able to supervise the flow

of these carriers, controlled imperfections must be “built in.” These imperfections are produced by impurities introduced into the crystal while it is being formed.

Two types of current carriers within a semiconductor cause it

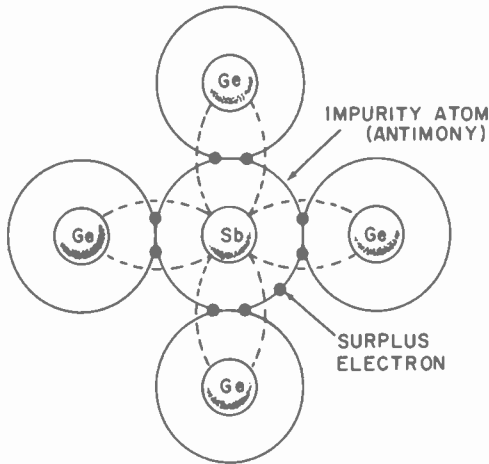

Fig. 110. Donor-impurity atom in the semiconductor lattice.

to conduct electricity—holes and electrons. A hole is nothing more than the space left by an electron that has been removed. For instance, take the four atoms of germanium in Fig. 108 and insert an atom of antimony or arsenic in place of the central atom (Fig. 110). These new atoms both have a valence of 5. This disturbs the lattice in such a way that only four of the five electrons form co-valent bonds with four neighboring atoms. The fifth electron is loosely attached to the atom and easily detached from it, even at low temperatures. This electron forms no bond with any atom and acts as a surplus electron. Place one of these impurity atoms in every n th space within the crystal lattice and you will have a solid which conducts electricity. Since this type of impurity provides excess electrons, it is called a “donor” impurity and the germanium crystal “doped” with this impurity is called n-type germanium.

If, instead of adding an impurity to the pure germanium with a valence of 5, we add an impurity such as indium with a valence of 3, we come up with a new lattice structure as shown in Fig. 111). Instead of four or five valence electrons we now have three and the space left by what would normally have been filled by an electron is called a hole. This hole has a positive charge and

readily accepts electrons to balance the arrangement. But, since the indium atom can support only three electrons in its outer ring, whatever electron that may be captured can be easily removed.

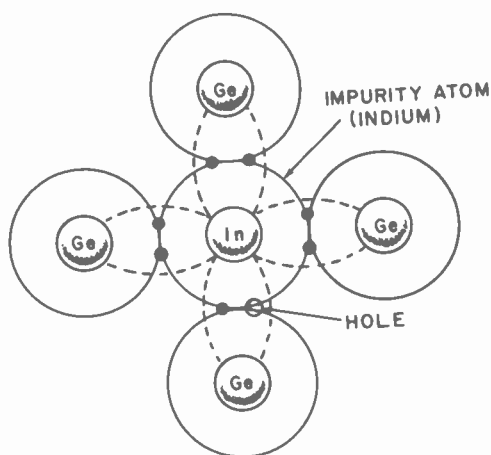

Fig. 111. Acceptor-impurity atom in the semiconductor lattice.

This type of impurity is called an "acceptor" impurity and germanium that is "doped" with this impurity is called p-type germanium.

Current flow: holes and electrons

Whenever current flow is mentioned, we automatically visualize electrons flowing through a conductor, or vacuum, from the negative terminal to the positive. We know that current flow is from negative to positive because the electrons that form this current are negatively charged.

As an illustration of this, take the two charged bodies shown in Fig. 112. One body has a negative charge because it has a surplus of electrons, while the other body is positively charged because almost all of its loose electrons have been removed. When these two charged bodies are brought into contact with each other, the electrons start to flow from the negative to the positive body. If a meter were placed in series with the two, we would see the effect of this flow. This movement of electrons, then, is current flow and it continues until such time that the electrical charge in each body is the same.

Suppose the two charged bodies were the terminals of a battery and we placed a piece of n-type germanium in series with a meter

across the terminals of the battery. What would happen? Current would flow from the negative terminal through the germanium and the meter to the positive terminal. This is evidenced by the

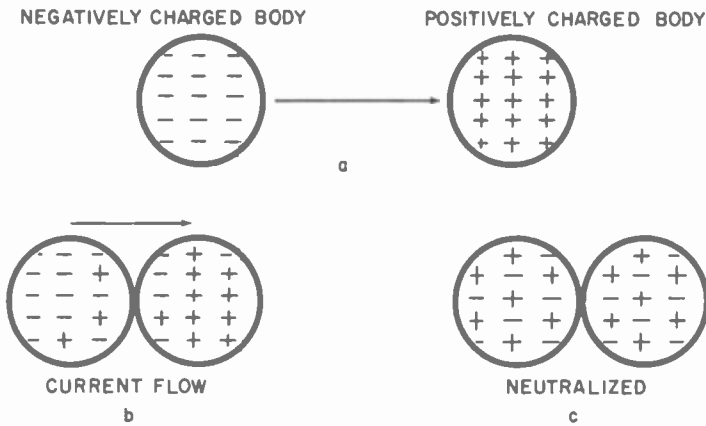

Figs. 112-a, -b, -c. Current flow between two oppositely charged bodies.

deflection on the meter (Fig. 113). Since n-type germanium is being used, we know that electrons are the major current carriers. Remember that in n-type germanium the impurity atom has one extra electron.

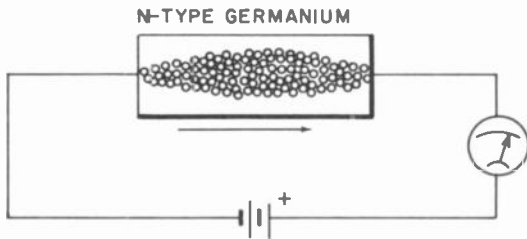

Fig. 113. Electron current flow in an n-type piece of germanium.

Suppose that instead of n-type germanium the p-type is used. What would be the result? The answer is the same as before but, theoretically, current will flow from positive to negative instead of negative to positive. In p-type germanium we know the impurity atom has one electron less than the germanium atom, and that the space left by this deficiency is called a hole. Since a hole is nothing more than the space left by an electron that has been removed (or never existed), it is logical to assume that it has a net positive charge of 1, as compared to the net negative charge of 1 of the

electron. Because the p-type germanium is deficient in electrons and has a surplus of holes, the major current carriers are holes. If a battery were connected to this germanium, all the holes would be attracted to the negative terminal. Therefore, since the holes are in the majority, the flow of current carriers is from positive to negative.

To understand hole flow in p-type germanium more clearly, use the analogy of the billiard balls on a billiard table, as shown in Fig. 114. The balls are lined up in a row between two cue sticks.

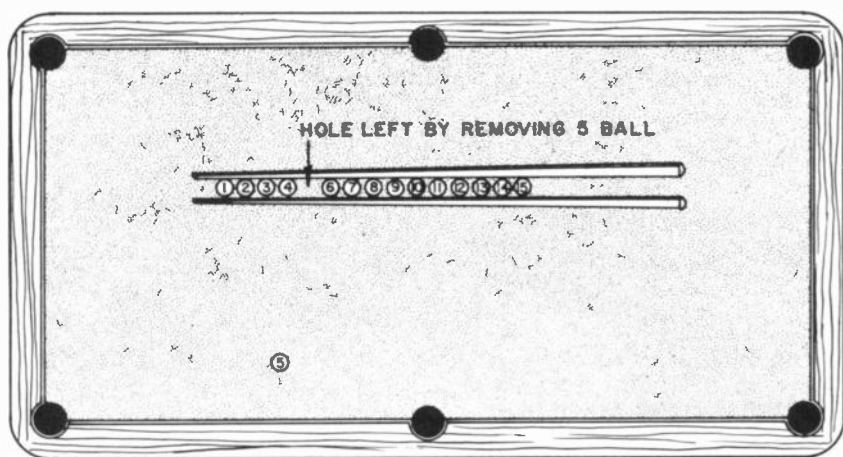
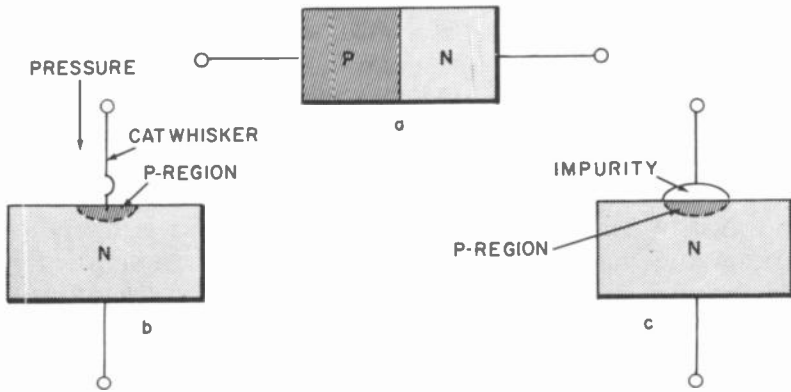

Fig. 114. Billiard-ball analogy of hole movement.

If the No. 5 ball is removed, an empty space is left between the No. 4 and No. 6 balls. This space is a hole. To fill it, the No. 6 ball is moved up leaving a hole between the No. 6 and No. 7 balls. To fill this space, the No. 7 ball is moved up, then the No. 8 ball, and so on down the line. As the balls are moved up one at a time to fill in the empty space, the hole moves farther and farther from the No. 4 ball and closer to the No. 15 ball, until it is where the No. 15 ball was. This is how a hole moves, assuming that the end near the No. 1 ball is the positive terminal and the opposite end the negative terminal. The whole process can be repeated by placing the No. 5 ball in the hole and removing the No. 1 ball, moving the remaining balls down the line one at a time.

The balls in this example represent electrons and, since we have two polarized terminals, you can see that they move from one terminal to the other in a direction opposite to that of the hole. This means that we have electron flow in p-type germanium. A

hole has a positive charge and therefore attracts a negatively charged electron. Since the negative terminal has a surplus of electrons, they are injected into the germanium, are captured by the atom and fill the hole. But, because this arrangement is unstable, they are eventually dislodged and find their way toward the positive terminal, leaving a hole behind to be filled by another electron. As the electrons move toward the positive terminal, the holes move toward the negative terminal. In p-type germanium,



Figs. 115-a, -b, -c. Three basic types of p-n junctions. (a) Grown junction. (b) Point contact. (c) Diffused or alloyed.

the electrons are considered minor current carriers. The mobility of a hole is governed solely by the movement or shifting of electrons.

Although holes and electrons cause current flow, in n-type and p-type germanium both holes and electrons are present and both can act as current carriers. In p-type germanium, however, the electrons are far outnumbered by the holes and, since the majority rules, the major current carriers are the holes. In n-type germanium just the opposite holds true. Here the electrons outnumber the holes and are the major current carriers.

The p-n junction: diode action

Combining p- and n-type germanium into a single crystal is the basis of both diode and transistor action. Fig. 115 shows the three basic types of p-n junctions. In Fig. 115-a, the p and n areas have been grown together into the crystal by adding both donor and acceptor impurities into the germanium melt while the crystal was being grown. This type of junction is known as a grown junction, and is not made up like a sandwich by placing p-type

germanium next to n-type. The junction consists of p and n layers that have been grown into a single crystal.

Fig. 115-b illustrates a point-contact type. A piece of n-type germanium, known as a wafer, is used in conjunction with a fine pointed wire, known as a catwhisker. This wire makes a pressure contact with the face of the germanium wafer. After the unit is assembled, a momentary, high current surge is passed through the unit. The heat generated disrupts the atoms in the area of the contact and drives some of the electrons of these atoms away. This leaves holes and converts a small portion of the germanium into p-type under and around the contact.

The arrangement of Fig. 115-c is known as a diffused junction. A pellet, or dot, of the impurity material is placed on one face of the germanium wafer. This is then heated and the impurity melts and diffuses into the wafer. The amount of diffusion is controlled by temperature and time. If the wafer is n-type germanium and the impurity is an acceptor, then the diffused impurity creates an area of p-type germanium within the wafer.

To understand the purpose of combining both p- and n-type germanium in a single crystal and to understand diode action, let us examine the p-n junction (Fig. 115-a).

In p-type germanium, holes are the major current carriers and in n-type germanium electrons do this job. When the two are placed side by side in a single crystal, without any voltage applied, the holes and electrons in each balance (Fig. 116-a). Current does not flow between them since no external electrical force is applied to disrupt this balance. Also, because of this, the junction appears as a very high resistance.

But, if we apply a voltage across this junction, as in Fig. 116-b, current starts to flow because the electrons in the n-type germanium are repelled by the negative terminal and the holes in the p-type germanium are repelled by the positive terminal. The holes and electrons are both driven toward the p-n junction where they combine. This causes the resistance of the junction to decrease to a value low enough to allow high conductance or current flow. Current continues to flow as long as voltage is applied. Under this condition, it is said that the junction (or diode) is biased in the forward direction.

If we reverse the polarity of the battery (Fig. 116-c) current no longer flows, since the electrons in the n-type germanium are now attracted to the positive terminal, and the holes in the p-type germanium to the negative one. The holes and electrons are both

pulled away from the junction and there is no appreciable recombination. The resistance of the junction is increased and a potential barrier is set up at the junction. Under this condition, the junction of the unit is said to be biased in the reverse direction.

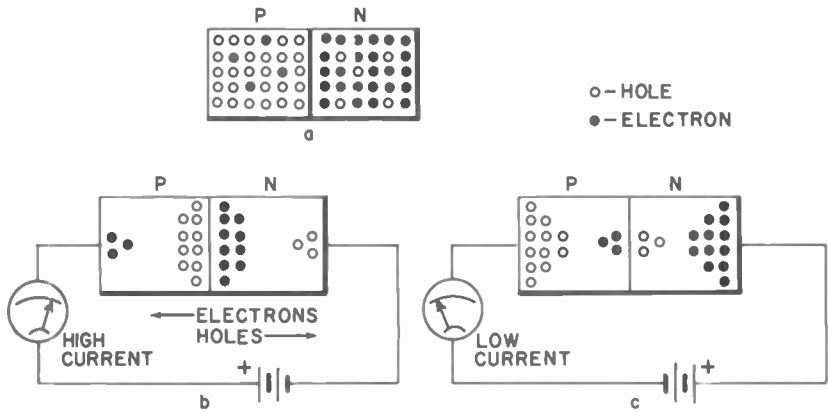

Figs. 116-a, -b, -c. Major current-carrier flow in a p-n junction. (a) Neutral. (b) Forward bias. (c) Reverse bias.

Some current does flow, however, due to minor current carriers. This current flow, which is just a few microamperes, is usually referred to as leakage current. The graph of Fig. 117 shows the static voltage vs. current curve of a typical p-n junction.

The p-n junction therefore, is a rectifier because of its ability to

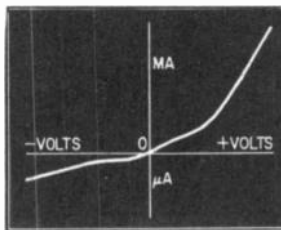
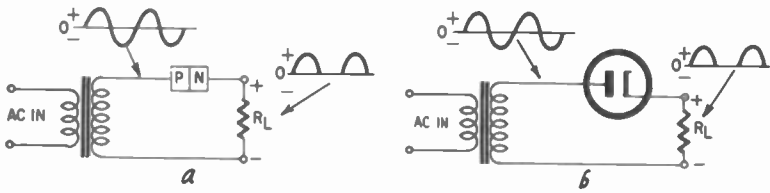

Fig. 117. Static voltage vs. current curve of a typical p-n junction.

pass current in one direction and practically no current in the other. Applying an ac voltage to this junction results in a dc output (illustrated in Fig. 118-a) similar to that produced by a vacuum-tube diode (shown in Fig. 118-b).

The static resistance characteristic of this diode is shown in Fig. 119. As the forward voltage is increased, the resistance decreases to a low value (about 100 ohms). As the forward voltage decreases

and approaches zero, this resistance increases to a value as high as several thousand ohms. The same holds true as the reverse voltage is increased. The resistance increases to several megohms,



Figs. 118-a, -b. Rectification of an alternating voltage. (a) Using a semiconductor diode. (b) Using a vacuum-tube diode.

passes through a peak and then starts to decrease. At the positive and negative extremes of this curve, there is a possibility of breakdown and burnout. These are the points where the properties and characteristics of the semiconductor are destroyed. This occurs when the heat generated by the current flowing through the semiconductor is sufficient to melt the germanium wafer or to cause the p and n regions to blend together.

The transistor

In the last two sections we learned about current flow in a semiconductor and how a semiconductor diode behaves like a rectifier.

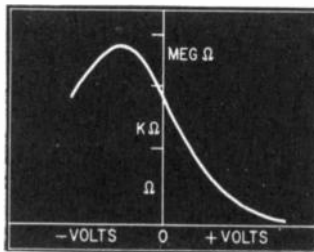

Fig. 119. Static resistance characteristic of a semiconductor diode.

The question now is, how do we get this semiconductor to act as an amplifier?

Referring once again to vacuum-tubes, let us take a simple diode and analyze it. The cathode, when heated to a certain temperature, emits electrons. These electrons are attracted toward the plate when a positive voltage is applied to it. The current flow between the cathode and plate is dependent upon the cathode

temperature and plate voltage (Fig. 120). To vary the amount of current flow between these electrodes either the plate voltage or cathode temperature is varied. This actually is doing it the hard way.

We get better results if we put a third electrode, called a control grid, between the cathode and plate. This grid is con-

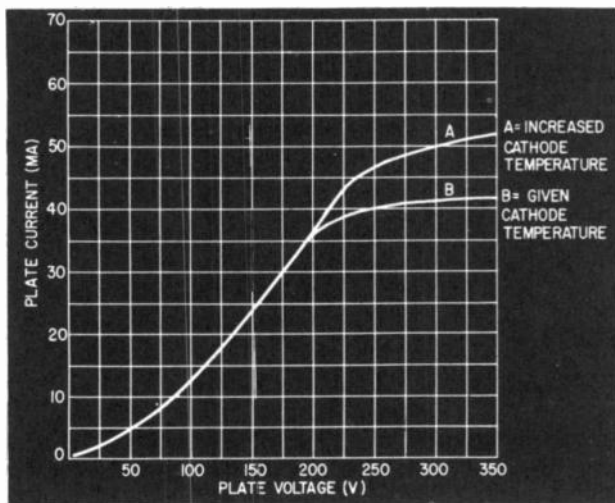

Fig. 120. Plate-current plate-voltage vs. cathode-temperature characteristic curve.

structed to allow electrons to pass through it easily on their way to the plate. If we apply a voltage to this grid, that is negative with respect to the cathode, the electrostatic field that surrounds the grid will repel electrons being emitted by the cathode, preventing them from reaching the plate. By varying the voltage on the grid, we can control the amount of electrons that flow from cathode to plate, even though the plate voltage and cathode temperature remain constant.

Looking at the plate characteristic curves in Fig. 121, we see that a very small change in grid voltage can effect a large change in plate current. If an ac voltage is applied to the grid, this voltage will be amplified in the plate circuit. The ratio of output to input voltage is called the amplification factor of the tube.

The same thing can be done with a p-n semiconductor diode. Only, instead of placing a grid between the two regions, a third piece of semiconductor material is used. This may be either

p- or n-type germanium, the difference being in the type of characteristics required.

Fig. 122 shows the basic construction of a transistor which uses

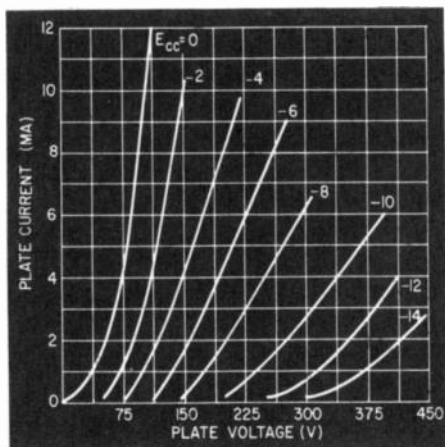

Fig. 121. Plate characteristic curves of a typical vacuum-tube triode.

two pieces of p-type and one piece of n-type germanium. The n-type is between the two pieces of p-type to form a p-n-p transistor. By reversing the order, an n-p-n transistor is formed. The action of the two is identical, the only difference being the

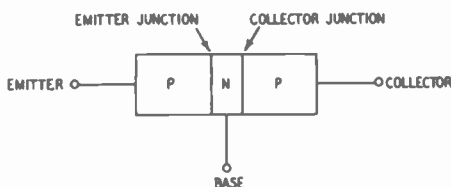

Fig. 122. Basic construction of a junction transistor.

polarity of the applied voltage and the identity of the major current carriers.

A transistor is actually two diodes connected back to back (Fig. 123) with the common electrode controlling the flow of electrons between the two outer electrodes. One diode is biased in the forward direction and the other diode in the reverse direction. The p region, for the diode which is biased forward, is called the emitter because, like the cathode in the vacuum-tube, it is the electrode which emits or injects the current carriers into the tran-

sistor. The p region in the reverse-biased diode is called the collector. Like the plate in the vacuum tube, it collects or attracts the current carriers. Since the n region controls the flow of electrons between the emitter and collector, much the same as the grid in the same vacuum tube, it is called the base.

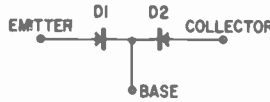

Fig. 123. A transistor is actually two diodes connected back to back.

By connecting the transistor as shown in Fig. 124 and applying a signal voltage to the base we have a simple one-stage amplifier. The positively biased emitter injects holes into the base region. Under the influence of the negative field of the collector, these holes pass through the thin base region to the collector to cause collector current flow. Some of these holes combine with the base

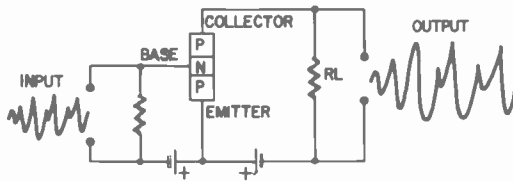

Fig. 124. A simple one-stage transistor amplifier.

electrons but, since the base region is very thin, the majority of them reach the collector.

This flow of current between the collector and emitter is easily controlled by the base. Applying a negative voltage to the base causes current to flow. Applying a positive voltage to the base stops this current flow. The reverse holds true for a n-p-n transistor.

The base controls the current flow by attracting and repelling the carriers which move from the emitter to the collector. In a p-n-p transistor, the emitter, being made of p-type germanium, injects holes into the transistor. If the base is made positive with respect to the emitter, the holes are repelled and no current flows. If the base is made slightly negative with respect to the emitter, the holes are attracted. Since the base region is very thin, these holes pass through the base and reach the collector, causing current flow.

In the n-p-n transistor the emitter is made of n-type germanium. Instead of holes, electrons are injected. A negative voltage applied to the base stops current flow and a positive voltage causes current flow. The action, however, is precisely the same as for the p-n-p transistor.

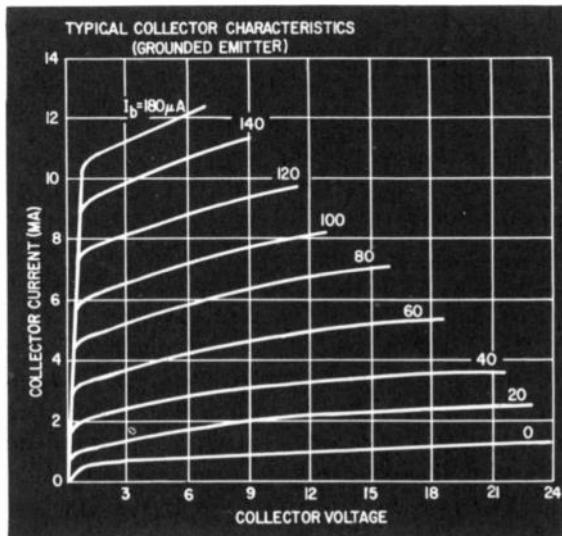

Fig. 125. Collector characteristic curves for a typical transistor.

A relatively small voltage is required on the base to cause a large collector current flow. If the emitter-collector e.m.f. is about 12 volts, a base-emitter voltage of 0.3 volt is all that is needed to cause a collector current flow of about 3 ma. Since the base attracts some of the current carriers, base current also flows. This current, though, is very low, values of about 20 microamperes being typical.

There is a current gain, as well as a voltage gain, in a transistor. Fig. 125 shows the characteristic curves for the collector of a typical transistor. By comparing it with the plate curves of Fig. 121, a similarity can be seen between transistor and vacuum-tube amplifying characteristics. In the vacuum tube we have grid voltage vs. plate current at a given plate voltage, while in the transistor it is base current vs. collector current for a given amount of collector voltage.

Junction transistors

A junction transistor consists of a germanium wafer (or other

semiconductor) in which three or more areas of conductivity exist. These areas consist of p-type material, in which the major current carriers are holes, and n-type material, in which the major current carriers are electrons.

The basic construction of a junction transistor (p-n-p) was shown in block form in Fig. 122. Here the emitter and collector consist of p-type material and the base of n-type material. Conversely, in an n-p-n transistor the emitter and collector are n-type material while the base is p-type. Fig. 126 illustrates the proper techniques of applying voltages to the emitter and collector of these two types.

To produce the desired p-n junctions in a transistor, several methods are used. In one, impurity metals such as indium (for

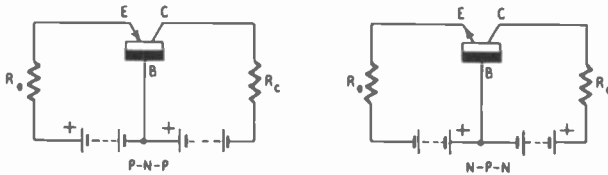

Fig. 126. Proper method of applying operating voltages to p-n-p and n-p-n junction transistors.

p areas) and antimony (for n areas) are introduced into the melt (molten germanium) while the crystal is being grown. This results in alternate p and n layers, the thickness of each layer being determined by the type of transistor to be made; that is, p-n-p or n-p-n. The grown crystal is then cut into bars at right angles to these layers and leads are attached to the three areas. Transistors made by this method are known as rate-grown junction transistors. Construction details are shown in Fig. 127.

A second method alloys or fuses the impurity metal to the germanium wafer. Dots or pellets of the impurity metal are placed on opposite faces of the wafer and then melted. The impurity diffuses into the wafer to form a p or n region, depending upon the impurity metal used. This fusing process is very carefully controlled during manufacture so that a specified width of n- or p-type germanium remains between the fused regions. Construction of this type of transistor is shown in Fig. 128.

Still another method, similar to the one just described, produces what is called a diffused-junction transistor. In this case the germanium wafer is placed in a sealed, heated oven. The impurity metal, which is to form the p-n junction, is vaporized and admitted into the oven in controlled amounts. Since only one face of the

wafer is exposed at one time the impurity penetrates into it and diffuses evenly to form the junction.

Another method produces a unique type called a surface-barrier

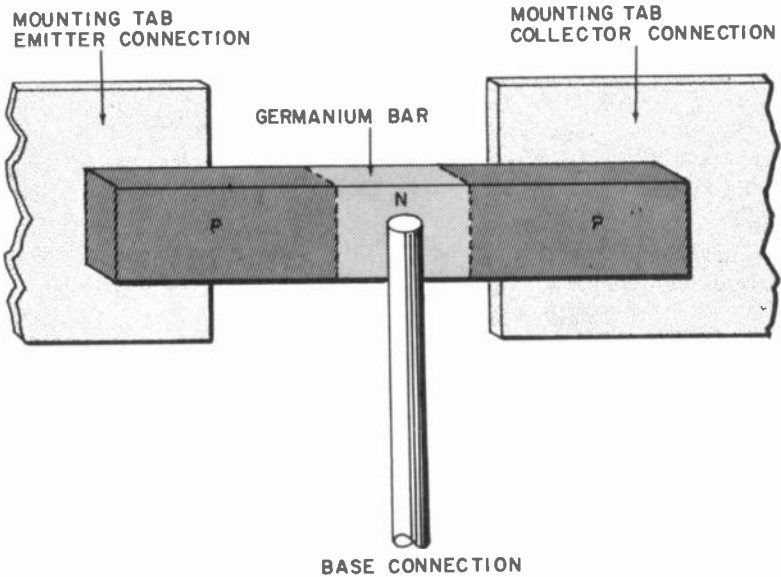

Fig. 127. Construction of a grown-junction transistor.

transistor (Fig. 129). This type, developed by Philco Corp., is not a true junction transistor since the impurity metal does not diffuse into the wafer nor does it have a grown p-n junction. It consists of a wafer of n-type germanium with metal contacts electroplated to either side. These contacts are the emitter and collector, and the metal used is indium (which produces the p-type region). During the process of manufacture, the opposite surfaces of the wafer are electrolytically etched to form cavities. The wafer between these cavities is about .0002 inch thick. When the desired wafer thickness is reached by this etching process, the emitter and collector electrodes are electroplated to the cavities. During plating, the collector area is made larger than the emitter for better current gain.

Despite the fact that it is not a true junction transistor, the unique construction results in a very high alpha-cutoff frequency and permits oscillation in the vhf end of the rf spectrum with very low collector voltage and current. The connections for the surface-barrier transistor are the same as those for a p-n-p unit.

Just one of the many forms and types of transistors in use at the present time, the junction transistor is the type found in

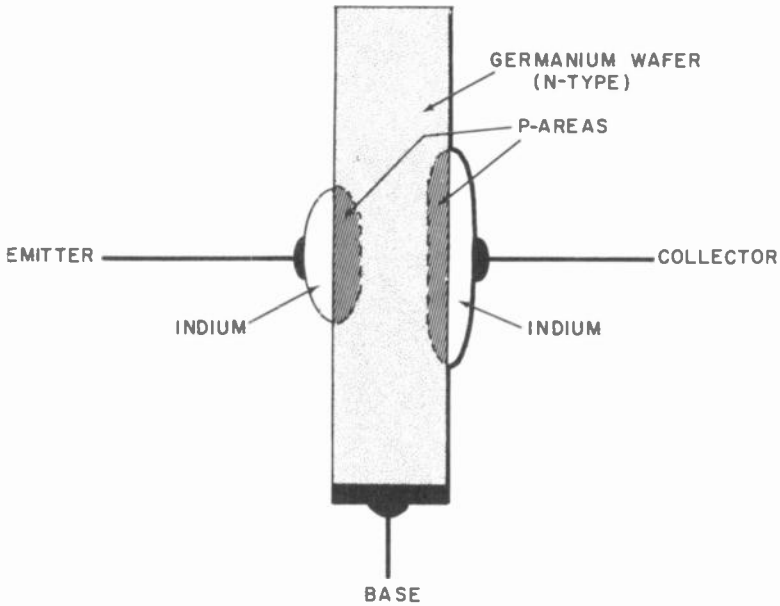

Fig. 128. Construction of a fused or alloyed-junction transistor.

transistor radios. Many others have been designed but are not widely accepted. One of these, gaining popularity in high-frequency work, is the tetrode transistor. It is basically an n-p-n junction unit in which an additional connection has been made to the wafer at the point opposite the base connection. This is shown in Fig. 130. This fourth connection is usually biased negatively with respect to the base connection. The purpose of this arrangement is to reduce the resistance of the wafer and to restrict, slightly, the current flow through it. This has the advantage of increasing the frequency response, although the power-handling capabilities are reduced. Fig. 131 shows the bias arrangement for this type of transistor.

Other types, either already developed commercially or still in the experimental stage, include the coaxial and the p-n-p-n grown-junction tetrode transistors, the double-base diode, and the field-effect, two-emitter contact and drift transistors, etc. All of these developments are aimed toward improved power gain, higher alpha-cutoff frequency and other specialized applications.

Transistor configurations

There are three ways in which a transistor can be connected in a circuit, depending upon what amplification and control char-

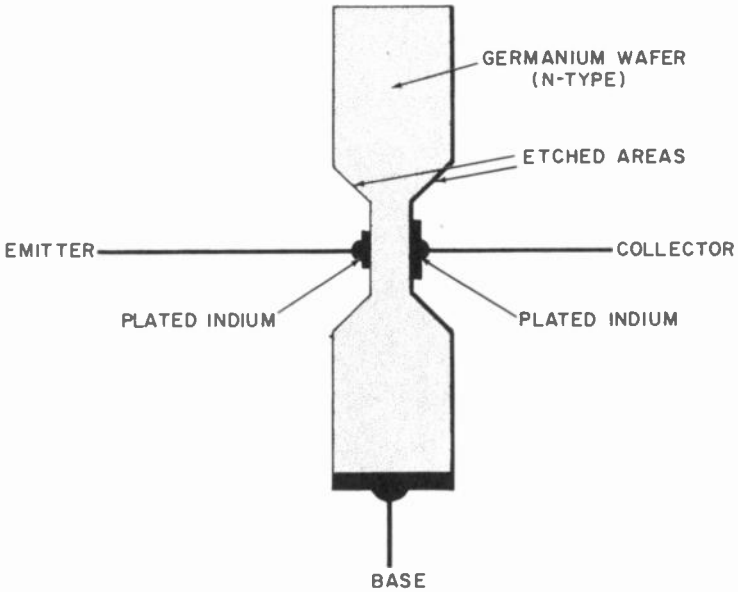

Fig. 129. Construction of a surface-barrier transistor.

acteristics are desired. These three circuits are similar to the grounded-grid, grounded-cathode and grounded-plate vacuum-

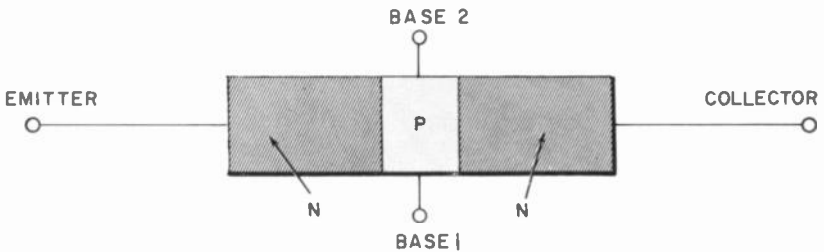

Fig. 130. Construction of the n-p-n junction tetrode transistor.

tube amplifier circuits. A comparison between transistor and vacuum-tube connections is seen in Fig. 132.

Fig. 132-a illustrates the grounded-base configuration equivalent

to the grounded-grid vacuum-tube circuit. The signal is applied between the emitter and ground, and output is taken from be-

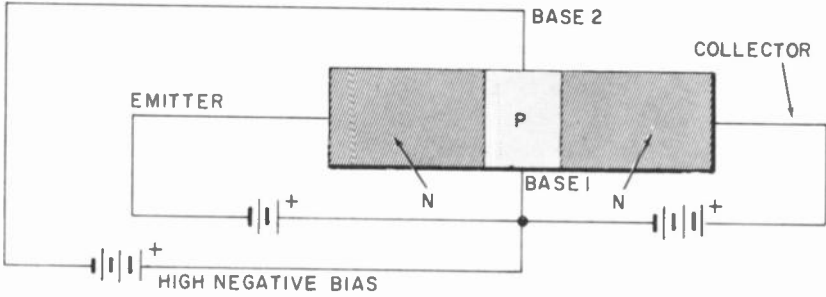
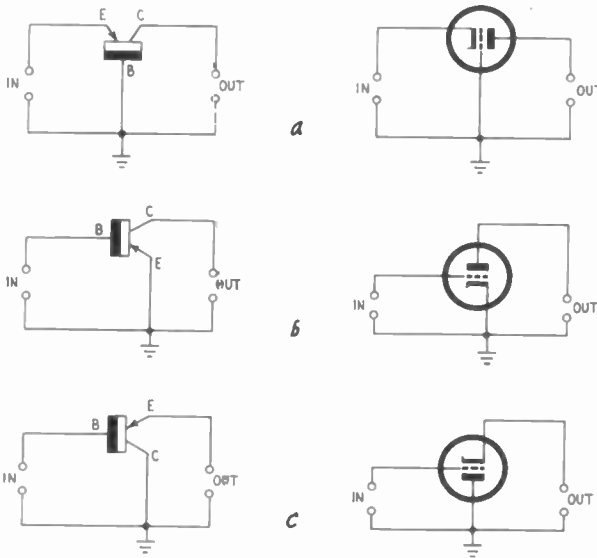

Fig. 131. Bias arrangement for the tetrode transistor.

tween the collector and ground. Like its vacuum-tube counterpart, this circuit is used where a low input impedance is to be matched to a high output impedance. Since the signal is applied



Figs. 132-a, -b, -c. Comparison of basic transistor and vacuum-tube circuits.

to the emitter (similar to the cathode in a vacuum tube), and the base is grounded, there is no signal phase reversal. Also, there is voltage amplification, but no current amplification.

The grounded-emitter circuit, shown in Fig. 132-b, is equivalent to the grounded-cathode vacuum-tube amplifier circuit. This circuit is the most commonly used, since it produces voltage *and* current amplification. It also provides the highest power gain of all. The signal is applied between the base and ground and taken from between the collector and ground. In this circuit there is a 180° phase reversal of the applied signal.

Fig. 132-c shows the grounded-collector circuit which is equivalent to the grounded-plate (cathode-follower) vacuum-tube circuit. It is used to match a high input impedance to a low output impedance and, like its vacuum-tube counterpart its voltage gain is less than unity (one) although current gain is high. There is no signal phase reversal. The common name for this circuit is emitter follower.

A comparison and the advantages of each of these circuits can be seen in the data given in Table 1-1.

Transistor characteristics

With vacuum tubes the basic parameters are plate voltage, plate current and grid voltage. These are used because the vacuum

Table 1-1.
Comparison of Transistor Circuits

CIRCUIT	INPUT IMPEDANCE	OUTPUT IMPEDANCE	POWER GAIN (db)	SIGNAL REVERSAL
Grounded-base	low	high	20-30	no
Grounded-emitter	medium	high	25-45	yes
Grounded-collector	medium	low	15-25	no

tube is a voltage-sensitive and voltage-operated device. In describing the operation of a vacuum tube, all terms and formulas are referred to these three parameters. That is, to determine the characteristics of the vacuum tube, the plate voltage and/or grid voltage, is varied and the resulting plate current is noted. The results obtained will tell you the gain, transconductance, etc., of the tube.

Since the transistor is a current-operated and current-sensitive device, two additional basic parameters come into play to make a total of five. They are: a) collector voltage; b) collector current;

c) base current; d) emitter voltage; e) emitter current. The last two can be compared to the cathode voltage and current in a vacuum tube, but unlike the vacuum tube these two parameters are independent of collector voltage and current.

From these five parameters the remaining parameters that pertain to transistor operation can be obtained. As an example, the static resistance of the emitter diode (r_e) can be obtained by dividing the emitter voltage by the emitter current. The static

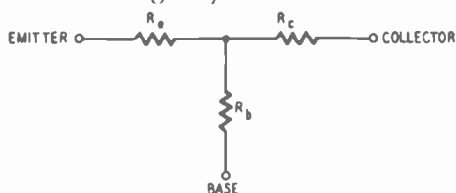

Fig. 133. Equivalent 3-terminal resistance network of a transistor.

resistance of the collector diode (r_c) can also be obtained by dividing the collector voltage by the collector current.

At dc voltages and low audio frequencies, the internal resistance components as seen from the three terminals of the transistor can be represented by an equivalent three-terminal network, as shown in Fig. 133. Resistors r_e , r_b and r_c represent the emitter, base and collector respectively. The base resistance r_b depends upon the resistivity of the germanium wafer. All of the compo-

Table 1-2.
Transistor Input and Output Resistances

CIRCUIT	INPUT RESISTANCE	OUTPUT RESISTANCE
Grounded-base	$r_e + r_b$	$r_c + r_b$
Grounded-emitter	$r_b + r_e$	$r_c + r_e$
Grounded-collector	$r_b + r_c$	$r_e + r_b$

nents, however, have a direct effect upon the input and output resistances of the transistor as shown in Table 1-2.

Because of the bias arrangements for transistors, the emitter with its forward bias has a very low resistance, a typical value being about 300 ohms. Since the collector is biased in a reverse direction, the resistance is high. Values may range from 10,000 ohms to 1 megohm. Because of this, the transistor is considered

point. It is this point that sets the limits within which the transistor will perform satisfactorily.

Since a transistor, like a vacuum tube, operates along a load line, the operating point can be determined by drawing a base bias curve on the transistor's collector characteristic curves, as

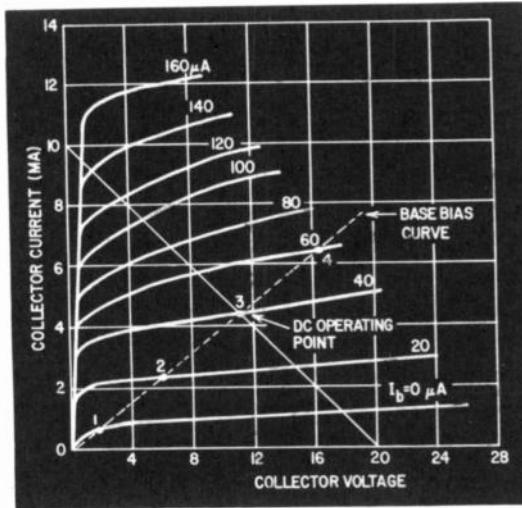

Fig. 135. Base-bias curve plotted on collector characteristic curves to determine dc operating point for the transistor.

shown in Fig. 135. The base bias curve is obtained by noting that for every value of collector voltage a certain amount of base current flows. On each base current line of the collector curves, there is a point on the bias curve at the collector voltage which corresponds to the base current. Connecting these points will show that the base bias curves intersect the load line. This point of intersection is the dc operating point of the transistor.

To bias the transistor at the dc operating point, one of two methods is used: fixed base-current bias or self base-current bias. In fixed base-current bias (Fig. 136), the base resistor is connected between the base and the collector supply voltage. The value of this resistor is such that the base current is constant. This method of biasing is the simplest, but it does not allow for any variations in transistor characteristics since the dc operating point is quite sensitive to any changes in the transistor.

In the self base-current bias setup (Fig. 137), the base resistor is connected between the base and collector. Any variation in collector voltage causes a change in base current. In this way, devia-

tions in transistor characteristics are compensated for, and the dc operating point always tends to remain at, or near, the desired condition.

The value of R_b , in fixed base-current bias operation, may be determined by the formula:

$$R_b = \frac{V_{cc}}{i_b}$$

and for self base-current bias operation by:

$$R_b = \frac{V_c}{i_b}$$

where V_{cc} is the collector supply voltage, V_c the collector voltage and i_b the base current.

This biasing of the transistor is the same as the biasing of a

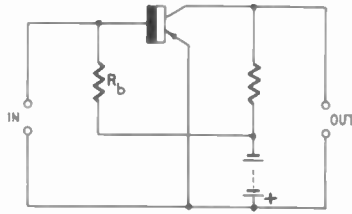

Fig. 136. Fixed base-current bias operation.

vacuum tube. In the schematics of Fig. 138, we see self-bias and fixed-bias operation of a typical vacuum-tube triode. In fixed-bias

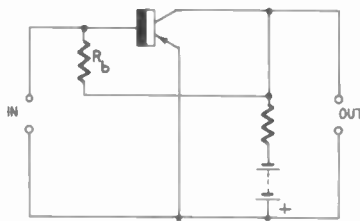

Fig. 137. Self base-current bias operation.

operation, the biasing resistor is in the cathode circuit, fixing the value of grid voltage. If the signal input voltage exceeds this value of bias, the output signal voltage is distorted. In self-bias operation, more commonly known as “bootstrap” bias, if the input signal voltage exceeds the cathode-to-ground voltage, distortion

will not occur since the bias voltage (between the grid and cathode) remains constant.

Bias stabilization

To obtain the best performance from a transistor, the dc operating point must be stabilized to prevent it from shifting. Such a shift is usually due to increases in the ambient or operating temperatures and sometimes to variations in the manufacturing proc-

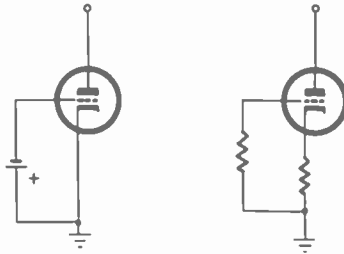

Fig. 138. Fixed-bias and self-bias operation of a typical triode vacuum tube.

ess. The system that is used to prevent this shift is called bias stabilization.

Three methods that are used to obtain bias stabilization are: current feedback; current feedback with fixed bias; current and voltage feedback.

Current feedback is used in the circuit shown in Fig. 139. Here the dc operating point of the transistor is determined by resistor R1, while the current feedback is provided by resistor R2. To visualize the operation of current feedback, let us suppose that for some reason the collector current in this transistor suddenly increases. Since this is a grounded-emitter circuit, we know the emitter current is equal to the collector current. Therefore, if the collector current increases, the emitter current must also increase. The increase in emitter current causes an increase in the in the voltage drop across R2. This voltage drop is subtracted from the supply voltage and means that a smaller voltage now exists between the emitter and collector. So, the higher the collector current goes, the less voltage that exists between the two electrodes. The smaller this voltage becomes, the less current that can be drawn by the collector and the smaller the danger of damaging or destroying the transistor.

The dissipation of the junction remains constant, since the change in collector voltage is proportional and opposite to the change in collector current. The dissipation of the junction is

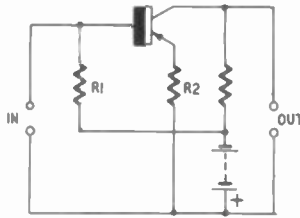

Fig. 139. Current-feedback operation.

dependent upon the peak values of collector voltage and current, during operation. There is a limit, though, at which point this type of protection is no longer effective.

Fig. 140 shows the circuit of an amplifier using current feedback and fixed bias. The ratio of resistors R_1 and R_2 determines the dc operating point while their parallel resistance controls the amount of stabilization. Actually, the resistors are used as a voltage divider with the base connected to the junction of the two for constant current. Current feedback is provided by resistors R_2 and R_3 .

The amplifier circuit shown in Fig. 141 makes use of current and voltage feedback. Here resistors R_1 and R_2 determine the dc operating point while R_2 and R_3 provide current feedback. Re-

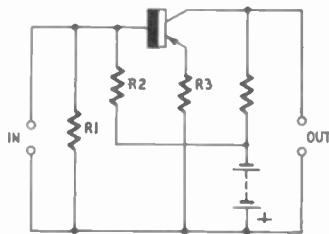

Fig. 140. Fixed-bias and current-feedback operation.

sistor R_1 alone determines the amount of voltage feedback. As the collector current increases, the voltage drop across the load resistor also increases. Since the base is connected to the collector through R_1 , this change in voltage is reflected in the base circuit. As the collector voltage decreases, the base voltage also decreases,

causing a drop in base current. This in turn causes the collector current to decrease and brings it back to normal operation.

Frequency capabilities

Several factors determine the frequency capabilities of a transistor: wafer thickness, major current carriers, electron or hole transit time, electrode spacing, electrode capacitance, etc. All play a role in determining what the maximum operating frequency limit of the transistor may be. Some of these factors may be interrelated (that is; one of these characteristics can be dependent upon the other).

The time required for current to flow from the emitter to the collector, through the germanium wafer, is called transit time. The type of current carrier influences transit time and is therefore closely related to it. Since the movement of a hole is much slower than that of an electron, as the signal frequency is increased, a point is reached where the holes which flow between the emitter and collector are unable to follow these signal variations. This point, then, is the upper frequency limit of the holes. The same holds true for electrons.

If the spacing between the emitter and collector is increased or if the thickness of the germanium wafer is increased, the time required for current to flow between the two electrodes is also increased. Therefore, increasing the spacing between electrodes, or increasing the wafer thickness, adds to the transit time, which in turn lowers the transistor's frequency limit.

Because of the proximity of the electrodes in a transistor, capacitance exists between them. This capacitance affects the frequency response by a shunting effect, much in the same manner as an additional capacitor connected across an L-C circuit, lowering its resonant frequency.

Frequency response

The frequency response of a transistor is limited and is low compared to that of vacuum tubes. But changing methods of manufacture and improvements in the construction of transistors are slowly but surely increasing this limit. At present, there are commercially available transistors whose frequency limit is well above 200 mc, and already there are in the laboratories transistors whose frequency limit is at least 1,000 mc. Only lack of mass-production methods and high costs are keeping them from the open market.

A transistor's frequency response is identified by specifying its

alpha-cutoff frequency. This is the frequency at which the value of alpha drops to a point 3 db below its low-frequency value. The low-frequency value is usually taken at 1,000 cycles.

Although alpha cutoff indicates the maximum frequency at which the transistor may satisfactorily amplify a signal, voltage and power amplification can fall off significantly at a frequency below that. Interestingly, however, just about every transistor is able to oscillate at a frequency well above its alpha-cutoff point. As an example, one CK722 transistor experimented with, (alpha cutoff is 0.8 megacycle), was made to oscillate at a frequency of 10 mc! Although this was a rare occurrence, as a rule of thumb, transistors will normally oscillate at twice their rated cutoff frequency.

In contrast to junction types, with their degraded high-frequency performance, the surface-barrier transistor just begins to show its clear-cut superiority at radio frequencies. It is designed to give optimum performance at high frequencies.

Typically, a surface barrier transistor may have a cutoff frequency of 50 mc and a beta of 10! This means performance is excellent through the broadcast band and far into the shortwave bands. The surface barrier transistor gives this type of performance with only a volt of collector supply and a power consumption only one-tenth that of a junction transistor.

Effects of temperature

Whenever a body, such as steel, is heated to a point above its ambient temperature (the temperature, initially, of the space or air that surrounds the body), the activity of its molecules increases.

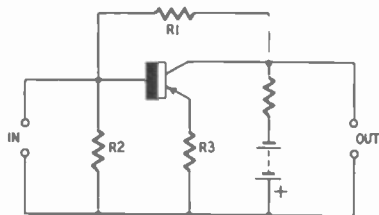

Fig. 141. Arrangement for obtaining current and voltage feedback.

As this body is heated further, a point is reached where the activity of the molecules is violent enough to cause electrons to be emitted. This is when the body is heated to a radiant red. At this stage, the violent activity of the molecules is such that the

body may melt or even vaporize into a gas, destroying the original form or property of the material.

This also holds true for a transistor. High temperatures tend to reduce the resistances between the emitter, base and collector because of an increase in molecular activity. This decrease in resistances means a higher current flow. A higher current flow causes heat, which can exceed the dissipation of the transistor reaching a point where its properties are permanently destroyed. Many times, too, the germanium wafer will melt. Increased temperatures, before damaging or destroying the transistor, reduce amplification and increase noise.

The average temperature range in which satisfactory operation can be obtained without any danger is from about 32°F to 135°F. Some transistors operate well above and below this range, but they are not types you will normally encounter in servicing transistor radios.

Transistor power requirements

It is normal to think in terms of watts, high voltage and high current when working with vacuum tubes and vacuum-tube radios, typical emf and current values being about 250 volts and 35 milliamperes. But, in transistor radios, the values are but a fraction of these.

Collector voltages rarely exceed 15, while collector and emitter currents may range anywhere from a few microamperes to a few milliamperes. In power transistors, though, the value of collector current is much higher, 1.5 amperes (or more) being a representative value.

Whatever the case may be, the power requirements for a transistor in a given circuit are much lower than those required by a vacuum tube performing the same function, especially if filament power consumption by the vacuum tube is considered. The overall efficiency of a transistor is much higher, too. It is because of this fact that transistors are able to operate as amplifiers or oscillators using power developed by a photocell, thermocouple or two coins separated by saliva-moistened paper.

Transistor types

Transistors have not become as standardized as vacuum tubes and few types are made by more than one manufacturer. Most of them are registered with the EIA (Electronic Industries Association) but many have not been and are designated by the manufacturer's own type number. It then becomes evident that to obtain

an exact replacement, in many cases, the same brand must be used as the original transistor in the receiver.

Transistors registered with the EIA have a prefix "2N" followed by a number—for example, 2N155, 2N145, 2N180, etc.

Wherever possible, the exact replacement transistor should be used. Also consult the interchangeability chart starting on page 186. While, in an emergency, it is possible to substitute another transistor type, extreme care should be taken in doing this. The characteristics of the replacement transistor should be compared with the original transistor to be sure that they are practically identical.

Transistors can be given a rough check for forward and back resistance similar to a method sometimes used for testing crystal diodes. A crude check can be made with a vtvm. This method gives only an indication of opens and shorts. Using the ohmmeter method is risky since some instruments often have higher voltages than the transistor can tolerate.

One of the major difficulties in obtaining a true measure of static characteristics of a transistor, by using the ohmmeter method, is that the value of test voltage is important and different voltages and meter movements are required to measure forward current and reverse current meaningfully. The forward current is in the order of milliamperes and should be tested at low voltages; the reverse current is in the order of microamperes and should be tested at higher voltages. For a satisfactory transistor test it is not only necessary to test for opens and shorts by checking forward and reverse resistance, but also for amplification ability.

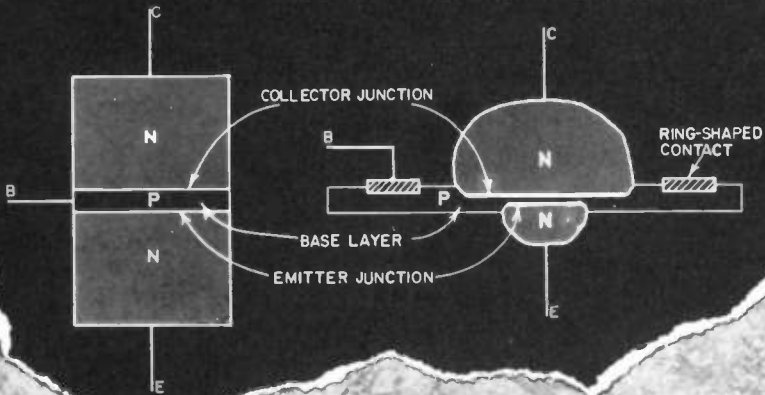
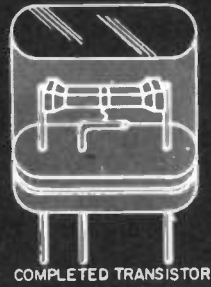
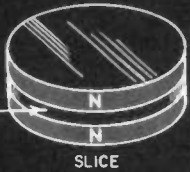
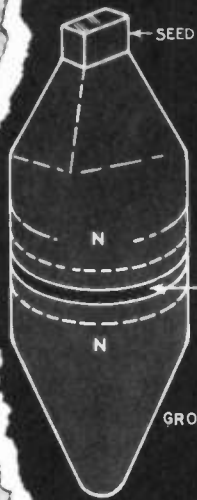

the transistor radio

BASICALLY a transistor radio and its vacuum-tube counterpart are alike. Both have a converter stage, one or more if stages, a detector, and one or more stages of audio amplification. A block diagram comparison is shown in Fig. 201.

From four to nine transistors are normally used in most units. The more elaborate circuits have a separate mixer and local oscillator, and may include a push-pull audio output stage. In any case the circuit most popular is that of a superheterodyne.

Fig. 202 is the schematic diagram of a typical transistor radio. Analyzing this circuit will clarify its operation. The modulated rf carrier signals of all the stations within the receiving area of the radio are "captured" by the ferrite-core antenna coil. These signals vary in frequency from 550 to 1600 kc. One station is selected by tuning the antenna coil, and its signal is passed on, by inductive coupling, to the base of the converter transistor V1. This converter performs two functions, just like a vacuum-tube converter. It operates as a mixer stage and, as a local oscillator, generates its own unmodulated rf waves.

The local oscillator is automatically set to a frequency about 455 kc above the frequency of the received signal. When the local oscillator signal and the received signal are combined in the mixer stage, the resulting output of the mixer is at a frequency of about 455 kc. This signal has the same audio modulation as the original signal applied to the base of the converter.

The 455-kc signal is fed to the first if amplifier stage and then to the second for further amplification. Both stages are fixed-tuned

at 455 kc to provide the well known selectivity and sensitivity of a superheterodyne.

The output of the second if is fed to the diode detector. It demodulates (or detects) the audio component and passes this audio into the audio amplifier stage, V4. The audio amplifier brings the level of the detector output voltage up to a point where it can drive a speaker.

The supply voltage for this radio is 9 volts, and the average current drain is 6 ma. Audio output power is about 18 mw. The overall power gain is 110 db with a sensitivity of approximately 200 μ v per meter. The transistors used are the p-n-p type, although

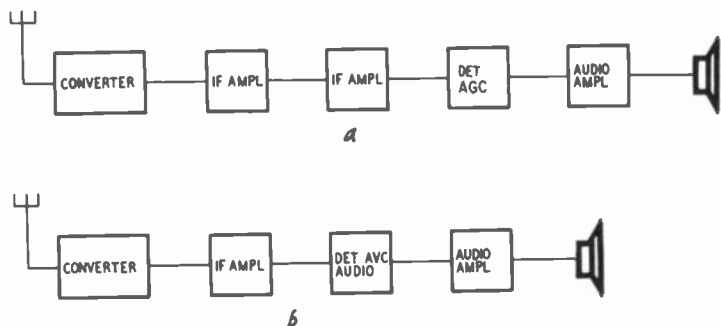

Figs. 201-a, -b. Comparison of radio receivers. (a) Transistor. (b) Vacuum tube.

n-p-n's can be used, provided the proper battery polarities are observed. Many radios use n-p-n transistors only, or combinations of n-p-n and p-n-p units.

Although the circuitry of a transistor radio is similar to that of a vacuum-tube set, there are many unique features which affect satisfactory operation.

The rf amplifier

Normally a transistor radio does not require preamplification of the received signals in areas close to broadcast stations. Nevertheless, where signals are weak, it is necessary to amplify them to a point where they can override background noise and be received intelligibly. This preamplification of weak signals is the function of the rf amplifier (commonly found in auto radios).

The amplifying capabilities of this stage are dependent upon the high-frequency power gain of the transistor. Usually transistors with an alpha-cutoff frequency of about 5 mc are used. Connection is normally in a grounded-emitter circuit.

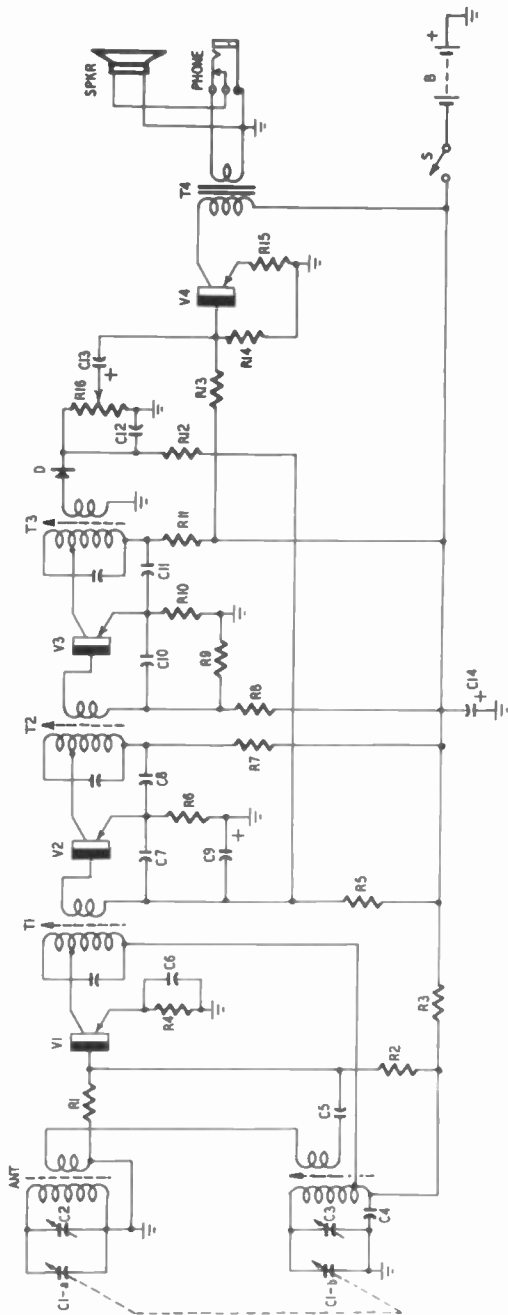

Fig. 202. Schematic diagram of a typical transistor receiver. There is no rf stage, V1 acting as a mixer-oscillator. T1, T2 and T3 are if transformers. These are tapped down for impedance matching. The output of the crystal detector, D, is fed through volume control R16 to the single-stage audio amplifier, V4. Optional speaker-telephone operation is provided. R4, R6, R10 and R15 supply self bias. Where these resistors are unbypassed they also supply negative feedback. C7 and C9 are age filters. C10, C11 and C12 are rf bypass capacitors. C13 is an aluminum or tantalum electrolytic coupling capacitor.

In a typical circuit (Fig. 203), the rf signal is applied to the transistor base by rf transformer (antenna coil, T1). Then, by transistor action, the signal is amplified and fed into the base of

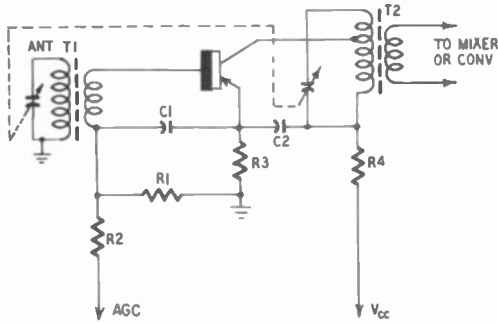

Fig. 203. Typical rf amplifier circuit.

the mixer or converter stage, through transformer T2. These transformers are continuously tuned throughout the broadcast band by variable capacitors.

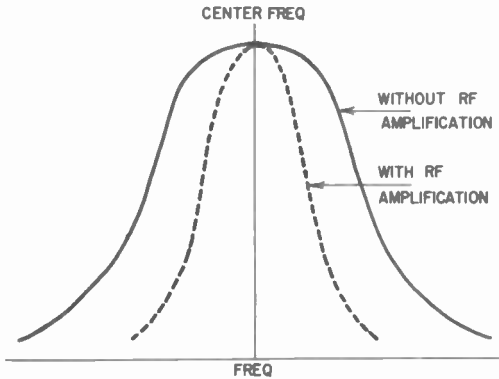

Fig. 204. Selectivity curve of a transistor radio with and without rf amplification.

The turns ratio of the primary to the secondary winding of each transformer is such that the base input impedance of each stage is matched as closely as possible to the high impedance of the antenna and rf amplifier collector circuits. This is to keep losses as low as possible, and to allow each stage to operate at optimum power gain. An important advantage of using an rf amplifier ahead of the mixer or converter stage is that it provides additional selectivity which helps reduce image frequency response. Fig. 204

shows the difference in selectivity of a transistor radio, with and without rf amplification.

Referring to Fig. 203, resistors R1 and R2 determine the dc operating point of the transistor, while resistors R1 and R3 provide for current feedback. Resistor R4 is used for decoupling.

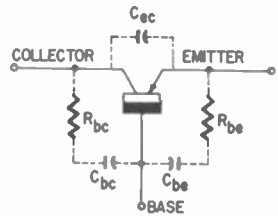

Fig. 205. Feedback components within a transistor.

Capacitors C1 and C2 are rf bypass units and complete the ac circuitry between the electrodes of the transistor.

Because of the internal resistive and capacitive feedback components present (Fig. 205), neutralization of this stage is usually required to prevent it from oscillating. This is accomplished by using a part of the output signal, applied in proper phase to the base, through a neutralizing resistor and capacitor as shown in Fig. 206. This type of neutralization can be compared to that used in vacuum-tube triode amplifiers (Fig. 207). The values of the capacitor and resistor depend on the amount of feedback capacitance and resistance present within the transistor.

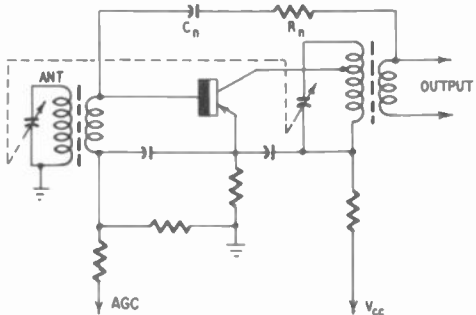

Fig. 206. Neutralizing the rf amplifier.

Actually, oscillation occurs only if the resonant frequency of the input circuit is the same as that of the output circuit and if the amount of feedback exceeds the value of $1/A$, where A is the gain of the stage. Therefore, if the resonant frequency of the output

circuit is lower or higher than that of the input circuit or the amount of feedback is less than $1/A$, oscillation cannot occur. The simplest method of preventing oscillation, then, is to slightly detune the output circuit. Although detuning reduces the gain of the

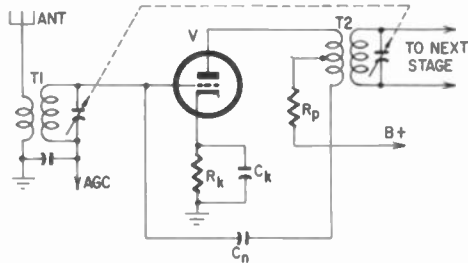

Fig. 207. Neutralization in a typical triode rf amplifier.

rf stage, this loss is readily absorbed by the overall gain of the radio. The gain of a typical neutralized rf amplifier is about 24 db,

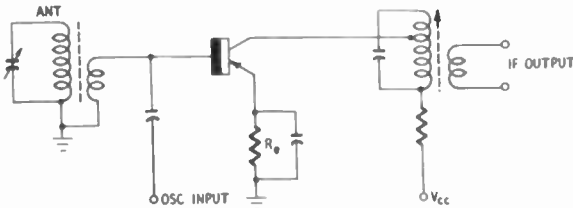

Fig. 208. Transistor mixer with rf and local-oscillator signals applied to the base.

while that of a slightly detuned, unneutralized rf amplifier is about 23 db.

To prevent overloading of the rf amplifier when tuned to strong

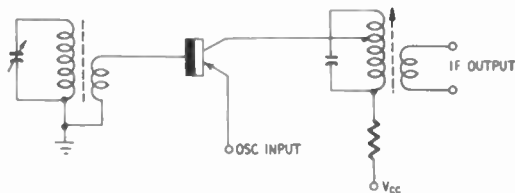

Fig. 209. Transistor mixer with rf signal applied to the base and local oscillator signal applied to the emitter.

signals or in a strong-signal area, agc is applied to the base. This agc, which varies in proportion to the received signal, controls the gain of the rf amplifier by controlling the amount of current flow-

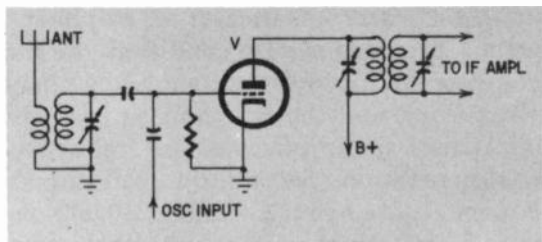

Fig. 210. Vacuum-tube triode mixer. Both rf and local oscillator signals are applied to the mixer grid.

ing through the emitter. Since the normal emitter current for this stage is 0.5 ma, for optimum gain, any increase in agc voltage decreases the gain of the stage. Any variation in the emitter current of a transistor also causes a variation in the input and output impedances of the transistor, which tends to reduce the gain further because of impedance mismatching.

The mixer

A transistor can perform the function of a mixer in a circuit similar to that used with a vacuum-tube triode. The rf input and

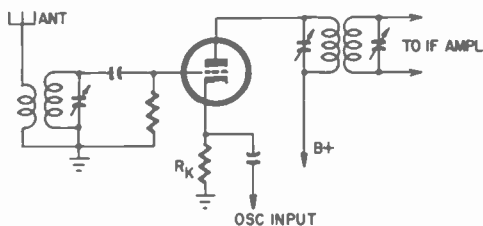

Fig. 211. Vacuum-tube triode mixer with rf signal applied to the grid and local oscillator signal fed to the cathode.

local oscillator signals can be applied simultaneously to the base, as shown in Fig. 208, or separately to the base and emitter as shown in Fig. 209. These circuits can be compared to their vacuum-tube counterparts of Figs. 210 and 211, respectively.

In either circuit, the signals mix in the emitter diode and, by transistor action, the current generated in this diode travels to the collector and is amplified. The mixing of these two signals and the

subsequent amplification of the difference, or intermediate frequency, is measured in terms of conversion gain.

The conversion gain of a mixer is only a few db less than the gain of the transistor when it is used as an amplifier at the intermediate frequency, provided certain conditions are met. First, the emitter and collector circuits must present a low impedance to the input signal frequency, and the base and emitter circuits should have a low impedance at the intermediate frequency. This is to prevent signal degeneration. Second, the load impedance for the difference frequency must be high (about 250,000 ohms) at a low emitter current. Third, the rf current amplification in the emitter diode must be high and, lastly, the alpha-cutoff frequency of

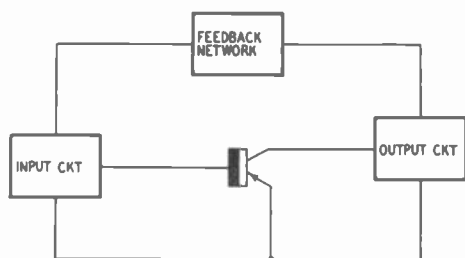

Fig. 212. Basic transistor oscillator circuit.

the mixer transistor should be high. When these conditions are met, conversion gains exceeding 20 db are possible well into the high-frequency region.

The mixer transistor is kept operating near or in the nonlinear portion of its characteristic curve for best detection. When the oscillator is not functioning, the emitter voltage is less than the base voltage. In the circuit of Fig. 208, resistor R_e provides a small dc bias which increases the conversion gain and reduces the oscillator drive requirements. This resistor is not absolutely necessary for operation of the mixer.

The average collector current for a mixer transistor is about 200 microamperes. Depending upon the design and required characteristics, this current can range anywhere from $10 \mu\text{a}$ to 1 ma. The lower the current, the lower the local-oscillator drive requirements. The drive is of the order of a few hundred micro-watts.

The transistor oscillator

A transistor oscillator is nothing more than an amplifier that has a portion of its output signal feeding back, in proper phase, to the

input. By proper choice of components, oscillations that extend from the sub-audio well into the high-frequency range can be produced.

Fig. 212 shows a transistor with a feedback network connecting the input and output circuits. If the transistor is acting as an amplifier, then the input signal is increased in amplitude from the input to the output circuit. A part of the output energy may be

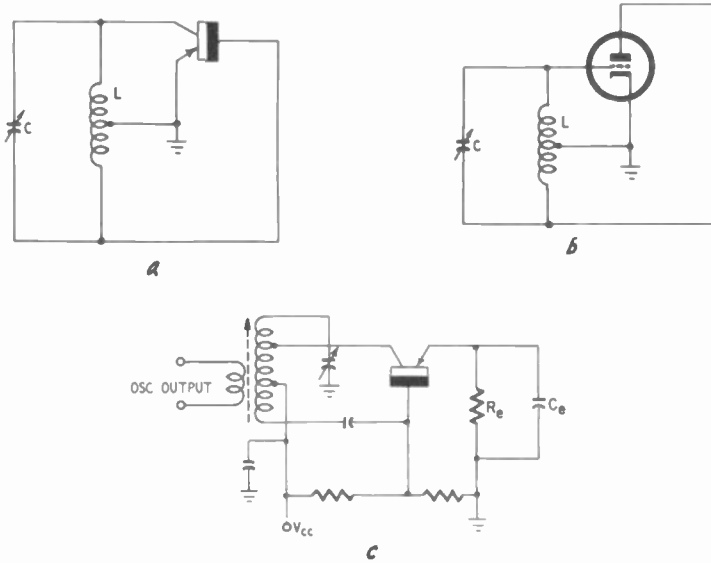

Figs. 213-a, -b, -c. Hartley oscillator. (a) Transistor circuit. (b) Vacuum-tube circuit (c) Typical transistor local-oscillator circuit.

fed back to the input and used to supply the input power. If this is done, the transistor will supply its own input signal and will oscillate at a frequency determined by the value of feedback components used. The transistor oscillates because any small current change in either the input or output circuit is transferred from one to the other via the transistor and feedback network.

Before this circuit can oscillate, however, the amount of signal fed back must exceed the value of $1/A$, where A is the gain of the stage as an amplifier. But, because of the low resistances present between the electrodes of the transistor, the value of $1/A$ must be much greater than that usually encountered in vacuum-tube oscillators. Therefore, the total amount of feedback *must* be equal to $1/A$ plus all losses.

The transistor local oscillator shown in Fig. 213-a is similar to

the Hartley oscillators shown in Figs. 213-b,c. This type is commonly used in transistor radios. Oscillation is developed in the manner just described, the necessary feedback resulting from the connection of the base and collector to opposite ends of the tank circuit.

The collector is positioned on the coil so that the proper impedance is presented to it, and the loaded Q of the circuit remains high. The dc collector bias is applied at the rf ground point of the coil. Oscillation occurs when the output energy from the

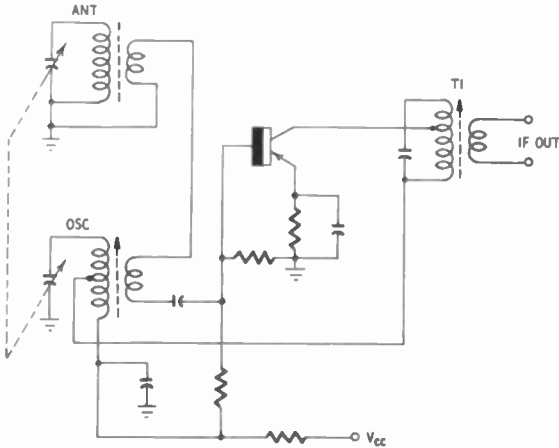

Fig. 214. Transistor converter circuit. Oscillations are developed between base and collector.

collector feeds through the coil winding and is coupled, both inductively and capacitively, to the base. The oscillator is tuned by a variable capacitor and an adjustable ferrite core that is inserted in the oscillator coil. Output from the oscillator is obtained from a tightly coupled link.

Dc requirements for an rf oscillator generally do not exceed 1 ma. Resistor R_e and the base resistors provide the proper dc operating bias for continued oscillations. Capacitor C_e is used to bypass the rf component that is present at the emitter.

The converter

Just about any transistor rf oscillator can be made to combine the functions of a mixer and local oscillator. This combination results in a circuit that is called a converter, the schematic of which is shown in Fig. 214. The circuitry of this converter and its operation closely parallel that of a vacuum-tube triode converter (Fig. 215).

A converter is nothing more than an oscillator to which two additional tuned circuits have been added. One circuit is inductively coupled to the base (to match the base input impedance), and it selects the incoming rf signal. This rf signal mixes in the

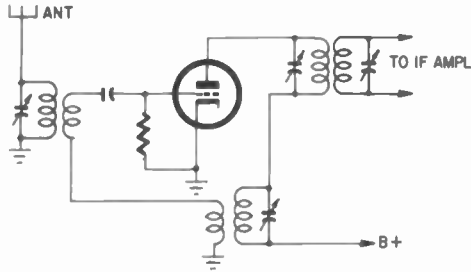

Fig. 215. Vacuum-tube triode converter.

emitter diode and then, by transistor action, the intermediate signal developed is amplified in the collector circuit. This intermediate-frequency signal is applied to the second tuned circuit. This is the if transformer, T1. The operation of the converter is much the same as that of a mixer, and the amplification factor is measured in terms of conversion gain.

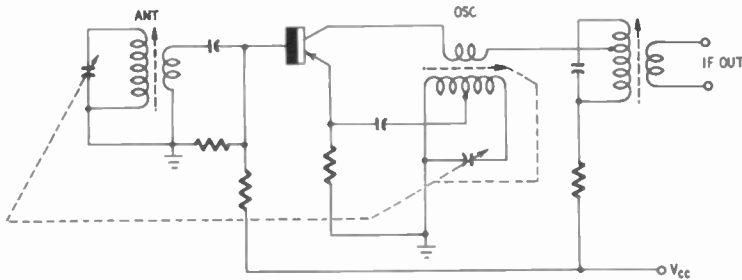

Fig. 216. Transistor converter circuit. Oscillations are developed between the emitter and collector.

As in a mixer, the conversion gain of a converter is only a few db less than the gain of the transistor when it is used as an amplifier at the intermediate frequency. The conditions required for successful operation of a converter are the same as those for a mixer. When all conditions are met, conversion gains exceeding 20 db are possible well into the high-frequency region.

The converter circuits shown in Figs. 214 and 216 are the most commonly used in transistor radios. The operation of the two is essentially the same, the only difference being in the way oscillation

is developed. In the oscillator of Fig. 214, it is developed between the base and collector. The output energy from the collector feeds through the tuned primary winding of the oscillator coil. By mutual inductance, this energy is transferred to the untuned secondary winding. Since the base is coupled to this winding, the energy is fed back through the coupling capacitor. This fed-back energy is then amplified and the whole process repeated to sustain oscillation. The circuit is actually a grounded-emitter amplifier with a feedback network.

In the oscillator of Fig. 216, oscillation is developed between the emitter and collector. In this circuit, the output energy from the collector feeds through the untuned primary winding of the oscillator coil. By mutual inductance, this energy is coupled to the tuned winding and the energy is fed back to the emitter through the coupling capacitor. The value of the emitter resistor is fairly high and it is not bypassed. Because of this, rf is present at the emitter. The circuit, therefore, is nothing more than a grounded-base circuit with a feedback network.

Both of these circuits are tuned by means of a variable capacitor and a ferrite slug in the oscillator coil.

The if amplifier

Following the mixer or converter stage is the if amplifier. Depending upon the receiver's characteristics and the manufacturer's requirements, from one to three stages of if amplification may be used. These stages tune and amplify the if signal before it is fed to the detector, so as to make possible the well known selectivity and sensitivity of the superheterodyne.

The amplification of the if stage depends mainly upon the high-frequency power gain of the transistor used. This is why the if stage is usually connected in the grounded-emitter circuit in preference to the grounded-base or grounded-collector circuit.

In the schematic diagram of Fig. 217, the if signal is applied to the base of the transistor by transformer T1. This signal is amplified and the output of the collector is applied to the base of the following stage through transformer T2. These transformers are tuned to the intermediate frequency, and the turns ratio of the primary to the secondary winding is such that the collector output impedance of one stage is matched as closely as possible to the base input impedance of the following stage.

The purpose of this arrangement is to keep as low as possible gain losses due to mismatching. Resistors R1 and R2 determine the dc operating point of the transistor, while R1 and R3 provide

for current feedback. Resistor R4 is used for decoupling. Capacitors C1 and C2 are bypass capacitors and complete the ac circuitry between the electrodes of the transistor.

Because of the resistive and capacitive feedback components present in the transistor, neutralization of the amplifier is usually necessary to prevent it from going into oscillation. This neutralization is accomplished with negative feedback. A portion of the

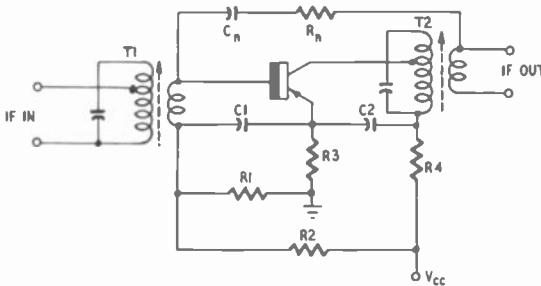

Fig. 217. Typical transistor if amplifier.

output signal is fed back to the input, in proper phase, through a neutralizing capacitor and resistor (C_n , R_n , respectively). This signal is obtained from the secondary of T2, since the base input impedance is low. If it were taken directly from the primary winding, it would load the collector circuit to a point where the selectivity of the if transformer would be very broad and the gain of the stage would be very low.

The values for C_n and R_n are dependent upon the values of feedback resistance and capacitance present in the transistor and on the turns ratio of the primary to the secondary winding of T2. In some transistors the value of feedback *resistance* is small enough to be ignored, while in certain of the newer types feedback *resistance and capacitance* are such as to make neutralization completely unnecessary.

To prevent overload of the if amplifier when the radio is tuned to a strong signal, agc is used. The emitter current is varied in proportion to the signal received. The action is a function of the signal level present at the detector. The emitter current for an agc controlled if amplifier stage is usually 0.5 ma. This bias is dependent upon agc considerations. Variations in emitter current cause changes in the stage gain and the input and output impedances. This is shown in the graph of Fig. 218. Note that the

input and output impedances increase as the emitter current decreases. This action further decreases stage gain because of impedance mismatching.

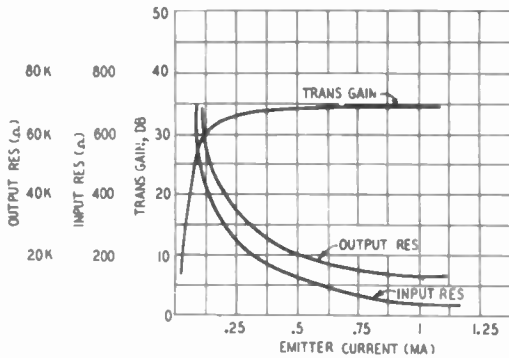

Fig. 218. Variation of transistor gain and input and output resistance with variation in emitter current.

To achieve automatic gain control of the if amplifier, agc voltage is applied to the base of the transistor, as shown in Fig. 219. When two stages of if amplification are used, the first is always the controlled stage while the second is operated at fixed gain. This

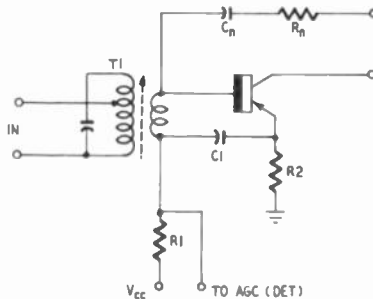

Fig. 219. Application of agc to base of transistor.

second stage is biased at 1 ma, or at the point of maximum gain. A circuit showing this type of arrangement is seen in Fig. 220.

Fig. 221 is a common-emitter amplifier with collector neutralization. The neutralizing voltage is obtained from the primary winding of the output if transformer. This method is similar to that used with vacuum tubes. The collector winding is tapped at approximately the midpoint, producing a neutralizing voltage op-

posite in phase to the voltage developed across the collector winding (for all practical purposes). This tends to cancel any feedback voltages developed. The feedback capacitance used is

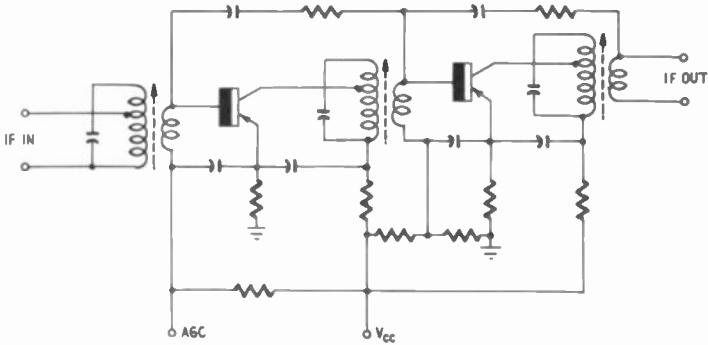

Fig. 220. Two-stage if amplifier with agc applied to the first stage and fixed-gain second stage.

equal to the feedback capacitance of the transistor, while the reactance of the neutralizing winding is equal to the feedback resistance. As in other if amplifiers, agc is applied to the base.

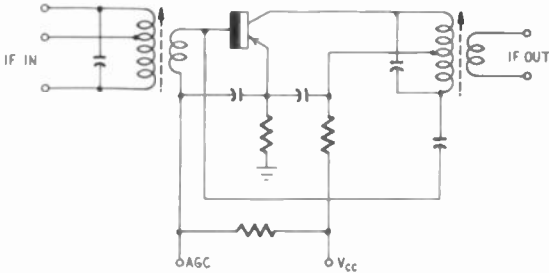

Fig. 221. Common-emitter amplifier with collector neutralization.

Fig. 222 illustrates the same type of amplifier; however, in this case a different type of transistor is used. Note that the tap of the feedback winding has been moved to a different position on the primary of the transformer and that a neutralizing resistor has been added in series with the capacitor. As mentioned, differing transistor characteristics determine both the size and type of neutralizing components needed. Also, the resistor is one way of controlling the amount of feedback (neutralizing) voltage required.

Fig. 223 is a grounded-base amplifier. Its power gain is low, but

cascading several stages makes up for the loss. The average noise figure for this circuit is equal to the noise figure for the transistor. In some cases it may be as much as 3 db lower. Configurations of

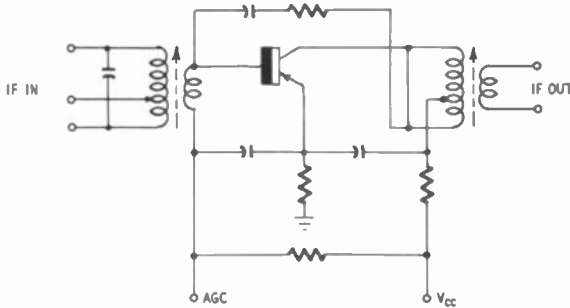

Fig. 222. Neutralizing network uses series resistor-capacitor arrangement.

this kind are often used where noise levels are of great importance. Agc is not applied to this particular circuit. If gain must be controlled, then a gain control potentiometer is placed in the emitter side of the base-bias network. Neutralization is required and is accomplished by the neutralizing capacitor and resistor connected

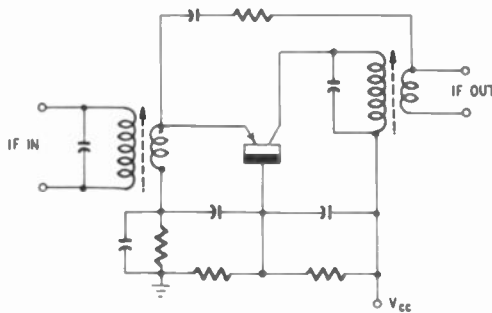

Fig. 223. Neutralized grounded-base amplifier.

to the *secondary* of the output transformer since no phase reversal is produced by the transistor.

Fig. 224 is a variation of the grounded-base amplifier shown in Fig. 223. Note that in this configuration agc is used.

Reflex if amplifier

Performing the function of amplifying if and audio signals simultaneously, the reflex amplifier was at one time very popular in vacuum-tube radios. Its popularity is once again increasing through its use in transistor radios.

A schematic of this type of amplifier is shown in Fig. 225, and the theory of its operation is simple. The if signal is applied to the base of the transistor through transformer T1. After amplification,

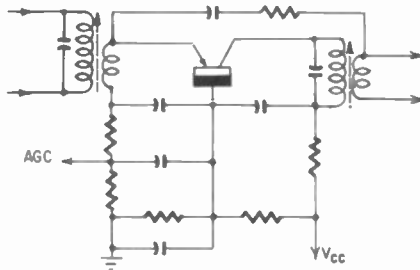

Fig. 224. Grounded-base if amplifier using agc.

this signal is applied to the detector through capacitor C1. The audio component appears across resistor R5, which is the diode load resistor and volume control. This audio passes through

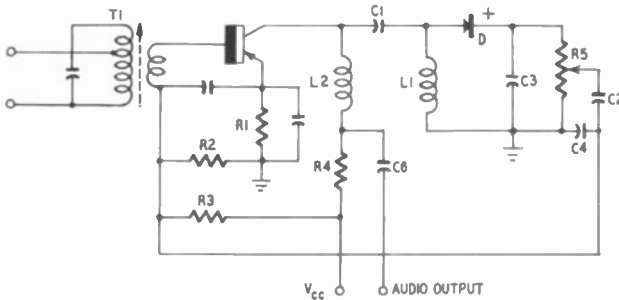

Fig. 225. Transistor reflex amplifier.

coupling capacitor C2 and the secondary winding of the if transformer T1 back to the base of the transistor. The transistor now reamplifies the signal, but this time at the audio frequency.

Since both the if and audio signals are present at the collector, some means of separating them is required. This is done by the choke L2 and capacitor C1. The reactance of L2 is low for the audio signal but high for the if signal, so only the audio can pass through. The value of C1 is too small for the audio signal to pass, but is large enough to allow the if signal to get through. Therefore, each signal after amplification goes its own way without interference from the other.

Audio output from this stage is taken from the junction of L2 and R4 and is coupled through capacitor C6 to the base of the audio output stage. Capacitors C3 and C4 bypass whatever if signal

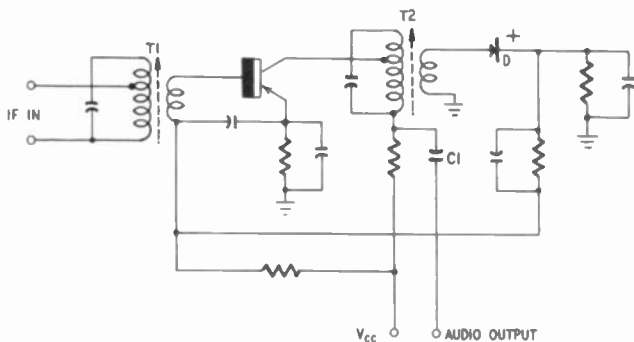

Fig. 226. Variation of the reflex amplifier shown in Fig. 225.

may be present in the detector output. The rf choke L1 completes the dc circuit for the diode detector, and its reactance is high enough to prevent loss of the if signal to ground. Resistors R1, R2 and R3 determine the dc operating point of the transistor and provide for current feedback. Resistor R4 serves as the audio load for the stage and as a decoupling resistor for the if signal.

The type of transistor that should be used in this circuit is the same that would be used in a conventional if amplifier circuit, although there are units designed specifically for use as reflex amplifiers. Normal operating bias in this circuit is 1.0 ma. The power gain for the if signal is about 32 db, and for the audio signal about 30 db. This gives a dual power gain of 62 db for a single transistor!

A variation of the circuit, using an if transformer instead of chokes, is shown in Fig. 226. Here the detector output is coupled directly to the base of the transistor for agc action. Capacitor C1 provides a low-resistance path for the audio signal. This type of circuit is used in transistor radios that do not have a second stage of if amplification.

The detector

In a transistor radio, the functions of detection and automatic gain control are usually accomplished in one circuit. They can be performed by a diode or a transistor. The choice, again, is dependent upon the design or manufacturer's requirements.

If a diode is used as the detector, its operation is the same as

that of any diode detector; that is, it rectifies the if signal, leaving the audio component. In the detector circuit shown in Fig. 227, volume control R1 is the diode load resistor. The audio signal

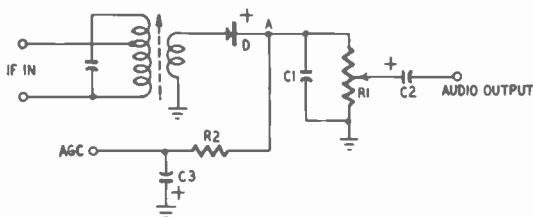

Fig. 227. Diode detector circuit.

that appears across it is coupled to the base of the audio amplifier through capacitor C2. Agc voltage is taken from point A, and resistor R2 and capacitor C3 act as a filter to remove any audio component that may be present in the line. Resistor R2 is also a part of the if amplifier base-bias network. The diode connection shown is correct if a p-n-p transistor is used in the if stage. If an n-p-n transistor is used instead, then the diode connections are reversed so that the proper polarity of agc voltage is applied to the transistor. Capacitor C1 is used to bypass any of the if signal present at the detector output.

When a transistor is used as a detector, it is biased at or near the point of collector cutoff so that it operates in the nonlinear portion of the transfer characteristic curve. Detection in the transistor can be assumed to take place in the emitter diode and the resultant signal amplified in the collector. A transistor detector has the advantage of providing about 10 db of audio power gain and a suitable agc voltage.

Both the audio signal and agc voltage are taken from the collector (Fig. 228). The basic operation of the detector depends upon the collector current flow. Under zero signal conditions, no collector current flows through the load resistor (since the transistor is biased at collector cutoff) and the collector voltage is approximately equal to the supply voltage. When a signal is applied, collector current flows through the load resistor, causing the collector voltage to decrease in proportion to the strength or amplitude of the applied signal. This change with signal strength of the collector voltage is used for agc.

When audio modulates the applied signal, the collector voltage varies with the audio. This audio voltage, amplified in the transis-

tor, is coupled to the following stage through a capacitor. Negative feedback (degeneration) for low-frequency compensation may be added to the detector circuit by a resistor in the emitter lead. This arrangement improves linearity but reduces gain.

Application of agc voltage to the if amplifier is a bit different

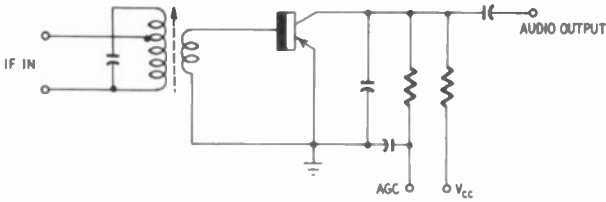

Fig. 228. Transistor detector.

from that in a diode detector. Whether a p-n-p or n-p-n transistor is used in the if stage, the connection is the same. As seen in Fig. 229, one base-bias resistor is used and it is connected directly to the detector collector. Although this type of connection is fairly common, the connection shown in Fig. 230 is also used. Here the collector load resistor R1 is a part of the base-bias network. Resistor R2 and capacitor C1 act as a filter to remove any audio component that may be present in the agc line.

Special agc circuits

The purpose of agc (automatic gain control) is to keep the output of the radio at a fairly constant level for various signal

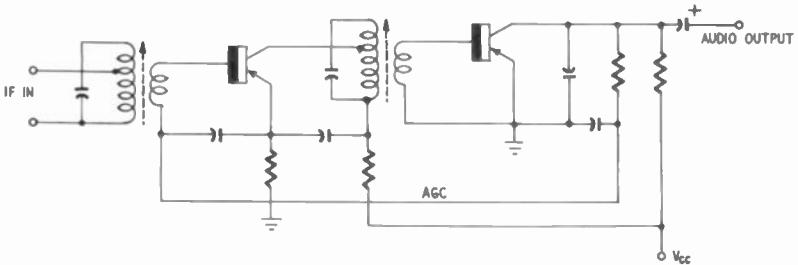

Fig. 229. Applying agc from the transistor detector.

strengths and to prevent overloading. Agc voltage can be taken from the primary or secondary circuit of the last if transformer. In the schematic of Fig. 231, the primary signal voltage is used. This is coupled to the agc detector circuit by a third winding, L3. When the signal-voltage polarity is as shown, the agc diode detector conducts through load resistors R1 and R2, producing a voltage

across the load. The if signal is removed by capacitor C1, leaving a dc voltage which is directly coupled to the base of the separate agc amplifier.

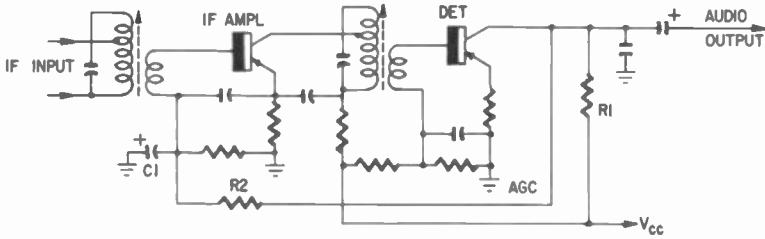

Fig. 230. Alternate method of applying agc to an if amplifier when using a transistor detector.

The negative agc voltage causes the transistor to conduct and current flows through it in the direction shown by the arrows. Resistors R3, R4 and R5 provide a ground return for the emitter resistor R6, and the current drawn by the agc amplifier produces a voltage drop across them. Since they are the emitter resistors for

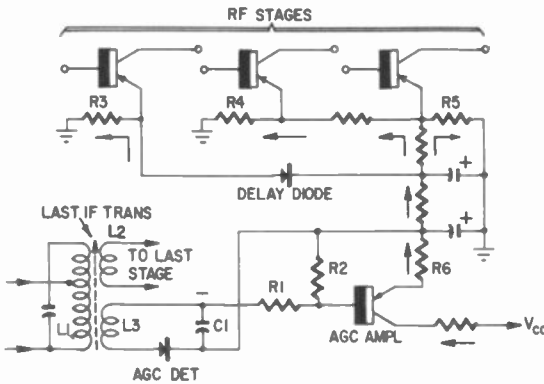

Fig. 231. Agc control of rf stages using separate agc amplifier.

the rf stages, the voltage drop produced by the conduction of the agc amplifier results in a greater-than-normal voltage drop across these resistors. This increase in voltage drop causes the emitter-collector voltage to be reduced (for each transistor). This means that less current will be drawn by each, reducing their gain.

The stronger the signal at the agc detector, the greater is its output. Consequently, the agc amplifier conducts heavily, producing a greater voltage drop across the emitter resistors of each con-

trolled stage. This, in turn, causes the gain of each stage to be reduced further, keeping the output level of the speaker fairly constant.

The diode connected in series with the agc line to the first stage is used to delay the application of the voltage to this stage. This delay keeps the stage operating at optimum gain over a wider range of signals than the remaining stages helping to prevent annoying flutter caused by momentary signal variations.

The audio amplifier

It is the purpose of the audio amplifier to amplify the detector

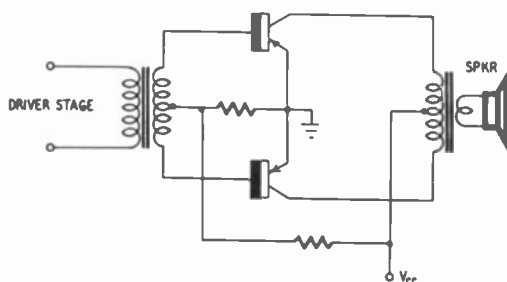

Fig. 232. Class-B power output amplifier.

output signal and to raise it to a level where it can be used to drive a speaker. In transistor radios, two types of audio amplifiers may be used for this purpose: class-A or class-B power output.

The most commonly used is the class-B push-pull amplifier, the schematic of which is shown in Fig. 232. The two transistors are connected in a grounded-emitter circuit to take full advantage of the high power gain of the units.

The emitter-base circuits of the two transistors are biased in the forward direction by the positive voltage (in reference to the collectors) applied directly to the emitters. A voltage-divider network is present between the positive side of the line and ground. The base of each transistor is connected to its emitter through one half of the input-transformer secondary winding and the resistor. Current flow through these resistors produces a voltage drop which is applied to each base. Therefore, the base of each transistor is at a slightly less positive voltage than the emitter, producing forward bias.

The collector of each transistor is made negative with respect to the emitters by the supply voltage. This insures good attraction for the major current carriers (holes) by producing a strong

negative field. The total collector current can be measured by inserting a millimeter (or ammeter) in series with the center-tap lead of the output transformer. This current is then compared with the required or normal current, as indicated by the data in the receiver service sheets. The current may be adjusted by varying the ground-return resistor in the base voltage-divider network.

The audio signal from the driver stage is coupled to the output stage by the input transformer. This is a stepdown device for proper impedance matching. As the base of one output transistor

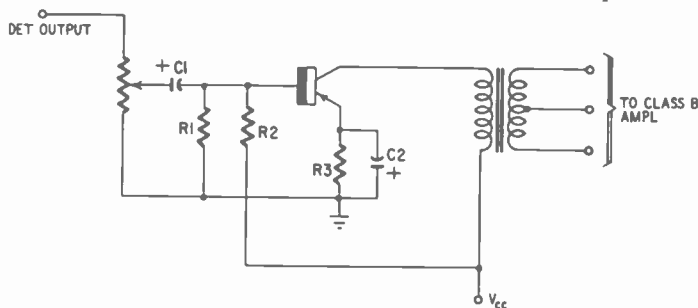

Fig. 233. Class-A driver amplifier.

is driven positive, the base of the other is driven negative. The increased forward bias of the base that is driven negative causes a surge in collector current. The base that is driven positive, having less forward bias, causes the collector current to decrease or cut off.

Depending upon the strength of the input signal, the collector current is completely cut off during a part of this half-cycle when the signal cancels all forward bias and causes the base-emitter diode to reverse its bias. The condition of the two transistors is reversed when the polarity of the signal reverses (second half-cycle). This is typical of class-B push-pull operation: current flows in one transistor and is cut off in the other during one half-cycle.

Since the class-B amplifier stage is biased close to collector current cutoff (for low standby power consumption) some power is required to drive it into the conduction region. The output of the detector is not strong enough to do this, so some means of amplification is required. This is where the class-A driver stage comes into play. The schematic of Fig. 233 uses a medium-power transistor that has a higher beta than the transistors used in rf circuits.

Audio from the detector is coupled to the base of this transistor

through capacitor C1. Resistors R1, R2 and R3 provide the proper forward bias for the transistor. To prevent degeneration of the audio signal, R3 is bypassed with a large-value capacitor (C2). This is the same as bypassing the cathode in a vacuum-tube amplifier.

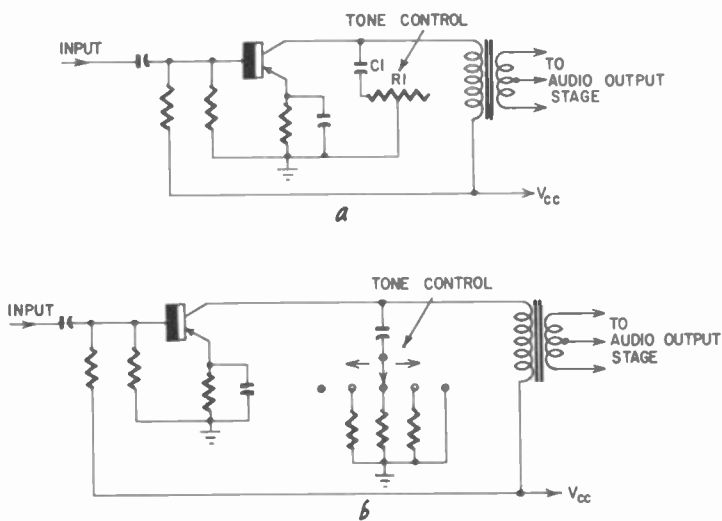

Figs. 234-a, -b. Placement of tone controls in audio driver-amplifier stage.

The amplified audio signal is then coupled to the class-B output stage by the driver transformer. This transformer is an impedance stepdown device for proper matching. Nominal power output for this stage is about 2 mw, but, depending upon the signal input power requirements for the output stage, it may be as high as several watts.

The receiver tone control is usually placed in this stage. In Figs. 234-a, -b we see two of several ways in which the tone may be varied. In a the tone control is continuously variable; in b it can be varied in steps.

The class-A power output stage (Fig. 235) is similar to the class-A driver. This stage normally works into a low load impedance for greater signal output. A driver stage can usually be changed into a power stage simply by changing the load impedance. But, unless the transistor used in a driver stage can handle high collector currents, the change is not advisable. The reason for this is that the transistor, with a low load impedance, can draw ac

in excess of the permissible maximum current, thereby damaging the transistor.

Fig. 236 shows a high-power class-A output stage. This amplifier

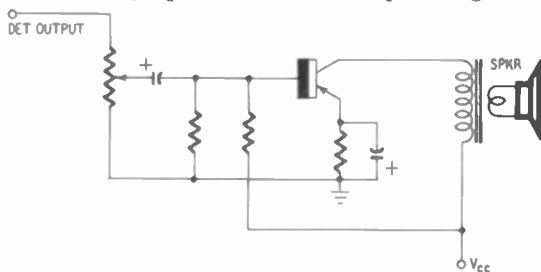

Fig. 235. Class-A power output amplifier.

can deliver upward of 2 watts of audio. Since the detector output is not strong enough to drive this amplifier it requires a driver stage (just as in the case of the class-B amplifier). The driver stage used is the same as that just described.

Many times the high-power transistors will get quite hot during operation. Unless there is adequate means for ventilation or heat dissipation (such as a heat sink), this heating of the transistor will cause "thermal runaway" of the collector current.

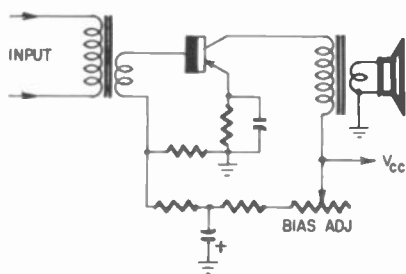

Fig. 236. High-power class-A output amplifier.

As the temperature increases during operation, the resistance of the transistor decreases, causing it to draw more current. The more current it draws, the hotter it gets. The hotter it gets, the lower the transistor resistance and the higher the current flow, until a point is reached where the temperature is high enough to damage or destroy the transistor.

One of many methods used to prevent this runaway condition is to insert a resistor in the emitter of the transistor or to use a

thermistor in the base-bias network. In Fig. 237 we see the former used in a class-A high-power output stage. We know that as the temperature increases, collector current increases. Since emitter current in a grounded-emitter circuit is the same as collector current, the current flowing through R1 causes a change in voltage across it which adjusts the bias and opposes the original current change.

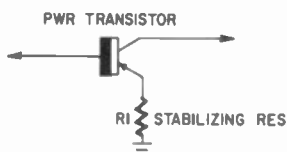

Fig. 237. Current-stabilizing resistor in emitter of power transistor.

In Fig. 238 a thermistor is connected across the base bias resistors. This thermistor is mounted close to the transistor and any change in temperature causes a change in its resistance. As the

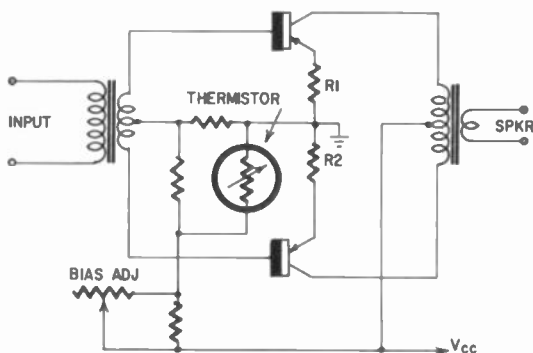

Fig. 238. Use of a thermistor in base-bias network to prevent "thermal runaway" of collector current.

transistor temperature increases, the resistance of the thermistor decreases, reducing the base bias voltage. Resistors R1 and R2 in the emitters also help to stabilize collector current and prevent thermal runaway.

Power transistors

The heat sink for a power transistor can be the metal chassis, or, as in the case of some auto radios, can be a ribbed radiator that presents a large surface area to the surrounding air.

Although the power transistor may seem to sit directly on the chassis or appear to be incorporated as an integral part of the heat sink, there is generally some insulation provided between the case of the transistor and the sink. The collector is usually mounted on a stud, generally an 8-32, and is made a part of the case or the "package" of the transistor. The case of the transistor is insulated from the chassis by a mica washer having a thickness of slightly more than .001 inch. The mica washer is often coated with silicone oil to permit a greater amount of heat transfer from the case of the transistor to the chassis. This washer must be replaced when transistors are substituted. In some power transistors a nylon bushing serves the function of a through-chassis grommet. Of course, in those cases where the collector is to be grounded, none of these precautions are required.



servicing techniques

WHenever a customer brings a transistor radio into the shop for servicing, the first comment is “I don’t know what happened, it just stopped playing.” No further information, no explanations. Just the demand, “Fix it!” How to fix it is of no interest to the customer, but can be a big headache to the service technician.

The problem of determining just what is wrong and locating the trouble can be solved by one or more of the following procedures.

Sight, smell, touch: This method is self-evident. Suppose the case is cracked. You’d know right off that the radio had been dropped or that it received a heavy blow. Components such as the tuning capacitor, speaker, etc. may have been damaged. Or, perhaps, upon opening the case you may see a broken resistor or smell a burned one. (Yes, resistors do char in a transistor radio!) Many defects are located this way, but relying on the senses alone does not always bring to light the cause of any particular radio’s failure.

Component substitution method: A known good part is substituted for the same part you suspect to be defective. This method is time-consuming though, and doesn’t always reveal the trouble, especially if more than one component is at fault.

Voltage measurements: Voltages at the base, collector and emitter of all stages are measured and compared with the values listed in the manufacturer’s service data sheets. Defective components usually are easily found with this method. Sometimes though, a faulty component may not change a voltage reading.

Signal substitution or signal tracing: A substitute signal is fed into the input of a stage. The output is then compared with a standard or with what is supposed to be a normal output. If the output signal is below par, then the troublesome stage is isolated and the component at fault can be located by substitution.

None of these methods is speedy or efficient when used alone. All are time-consuming but experience has shown that it is best to locate the defective stage first and then isolate and replace the defective component.

Test instruments

To service and repair a transistor radio successfully, it is necessary to have the proper test equipment on hand. Listed here

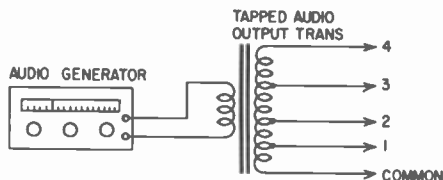

Fig. 301. Using a tapped audio output transformer provides for various output impedances.

are the basic units. With some exceptions, this equipment is standard in service shops.

Signal generator (af)

Must provide up to 1 volt across a 50-ohm load and be continuously variable from 20 to 20,000 cycles. The nominal output impedance should be 500 ohms, with taps at 50, 250, 1,000 and 2,000 ohms, to match various transistor input impedances.

If the audio signal generator has a fixed output impedance, then a tapped audio matching transformer may be used, as shown in Fig. 301, to provide the various output impedances. The type of transformer is dependent upon the output impedance of the generator. If the transformer that is required is not available commercially, then one can be made from an old audio or filament transformer.

Take the transformer apart and remove all wire from the coil form. On this form, wind about 250 turns of No. 28 enamel-covered copper wire. This winding is the primary and is connected to the signal generator. Cover this winding with a layer of Scotch electrical or vinyl tape. Over this is wound the secondary

winding, with taps for the proper impedances. After the secondary is wound, cover it also with a layer of Scotch electrical or vinyl tape. Slip the form over the core and complete the assembly of

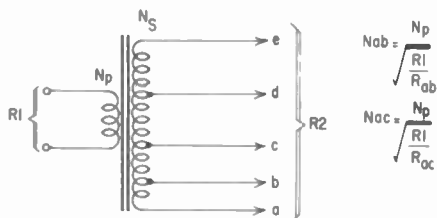

Fig. 302. Determining the number of turns required between taps on the output transformer.

the transformer. The two windings may be scramble-wound, but for better efficiency and neater work the windings should be in layers.

The number of turns required by the secondary and the position of the taps can be determined by the formula

$$N_2 = \frac{N_p}{\sqrt{\frac{R_1}{R_2}}}$$

where N_2 is the total number of turns in the secondary winding, N_p the total number of turns in the primary winding, R_1 the input impedance and R_2 the load impedance.

Since this formula is for the total number of turns in the secondary winding, it has to be modified so that the placement of the taps can be found. Referring to the diagram of the tapped transformer in Fig. 302, the following formulas can be used to determine the position of these taps.

$$N_{ab} = \frac{N_p}{\sqrt{\frac{R_1}{R_{ab}}}} \quad (1)$$

$$N_{ac} = \frac{N_p}{\sqrt{\frac{R_1}{R_{ac}}}} \quad (2)$$

$$N_{ad} = \frac{N_p}{\sqrt{\frac{R_1}{R_{ad}}}} \quad (3)$$

etc.

In these formulas, a load connected across a and b is denoted by R_{ab} and the number of turns in the secondary between these terminals is indicated by N_{ab} . Corresponding designations apply for any pair of terminals across which the load is connected.

As an example; $R_1 = 500$ ohms, terminals a and d are loaded by 1,000 ohms. What is the number of turns required between terminals a and d? By using our formula we have:

$$N_{ad} = \frac{N_p}{\sqrt{\frac{500}{1,000}}} \quad (4)$$

Since we know the primary winding has 250 turns we now have

$$N_{ad} = \frac{250}{\sqrt{\frac{500}{1,000}}} \quad (5)$$

$$N_{ad} = \frac{250}{\sqrt{0.5}} \quad (6)$$

$$N_{ad} = \frac{250}{.71} \quad (7)$$

$$N_{ad} = 353 \quad (8)$$

Therefore, the number of turns required between terminals a and d to match 500 ohms to 1,000 ohms is 353. It is the turns ratio and not the number of turns in each winding that determines the transformed or reflected load impedance.

To determine the position of the taps on the secondary winding, it is necessary only to use the formulas listed and to substitute

the required values. Since the secondary is just a single tapped winding, the number of turns required for each load determines

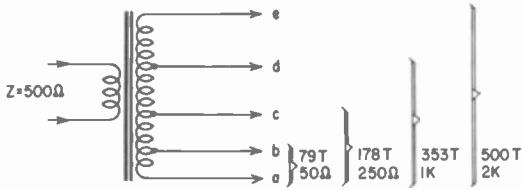

Fig. 303. The complete tapped output transformer.

the position of the tap on this winding. This is shown in Fig. 303 and the following table, based upon the calculations of the preceding example.

Load Resistance (Ohms)	Tap (turns)
2,000	500
1,000	353
250	178
50	79

Capacitor checker

A very important aid, it is used to determine the condition and value of a capacitor and should be able to measure values up to 200 μ f.

Signal generator (rf)

Should provide a modulated or unmodulated rf signal. When modulated, the modulating frequency should be 400 cycles for optimum results. If the rf generator does not have provisions for supplying a modulated signal, then the modulator shown in Fig. 304 can be used (external to the generator). This modulator is, in effect, a diode mixing circuit. The rf signal is applied to one input and the audio signal to the second input. The resulting modulated signal is taken from the output. Provision is made in this circuit to vary the output. This means that no juggling of the output controls of either the audio generator or rf generator is required to keep the output and percentage of modulation constant.

The nominal output impedance of the generator should be high, approximately 10,000 ohms, so that the generator does not

load the rf circuits when connected to them. A small capacitor or a few turns of wire as a coupling loop connected to the output

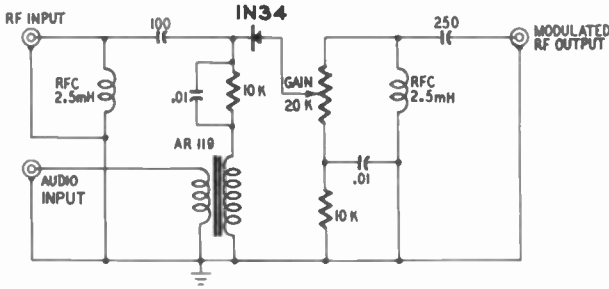

Fig. 304. External modulator unit for an rf signal generator.

leads will be adequate for coupling the generator to the circuits under test. This arrangement can be seen in Fig. 305.

Fig. 306 shows the output voltages and currents that are required and obtained from most signal generators.

Vacuum-tube voltmeter (dc)

Used to measure all dc voltages and to observe agc action, the dc vacuum-tube voltmeter must have an input resistance of at least

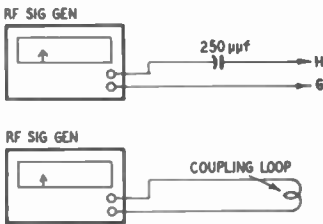

Fig. 305. Means of coupling the rf generator to circuits under test.

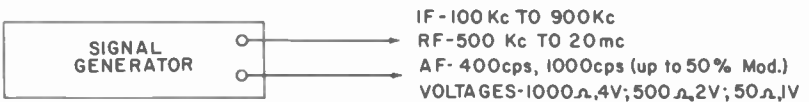

Fig. 306. Required output voltages from a signal generator.

10 megohms so that the meter does not load any circuits to which it is connected.

Vacuum-tube voltmeter (ac)

Used to measure all ac voltages and stage gain, its input re-

sistance must also be at least 10 megohms, shunted by a maximum capacitance of 10 $\mu\mu\text{f}$. The sensitivity should be a minimum of 10 mv, with a frequency range to 5 mc.

Ohmmeter

One of the basic instruments required in servicing, the ohmmeter should have a wide enough range to measure the resistances encountered in a transistor radio, usually 0 to 20 megohms.

Capacitor decade (substitution box)

Working in conjunction with the capacitor checker, the capacitor decade is used to substitute for a suspected defective capacitor in the radio and also to determine the value of the capacitor used. By switching, just about any value of capacitance may be obtained. The schematic of a capacitance decade, covering the values normally encountered in transistor radios, is shown in Fig. 307. The decade can be built into a metal Minibox or a cigar box. Leads should be kept as short as possible.

Resistance decade (substitution box)

Working in conjunction with the ohmmeter, the resistance decade is used to substitute for a resistor in the radio and also to determine the value of a particular resistance. By switching, just about any value of resistance may be obtained. The schematic of a resistance decade, covering typical values in transistor radios, is shown in Fig. 308. It can be built into a metal Minibox or a cigar box.

Substitute speaker

This is used to determine the value and condition of the output transformer and speaker. By switching, various load impedances from 250 to 20,000 ohms can be obtained to match the output impedances of the power transistors used in the radios. Provision should also be made for connecting the substitute-speaker voice coil directly to the radio output transformer. The schematic of a simple substitute-speaker assembly, which can handle up to $\frac{1}{2}$ watt of audio power, is shown in Fig. 309.

Signal tracer

A useful aid in locating a defective stage in a transistor radio, a signal tracer consists of a high-gain audio amplifier with a high input impedance. This high input impedance is required so that the signal tracer will not load the circuits to which it is connected. The gain of this tracer should be high enough so that, when an untuned diode detector stage is connected to it and also to an an-

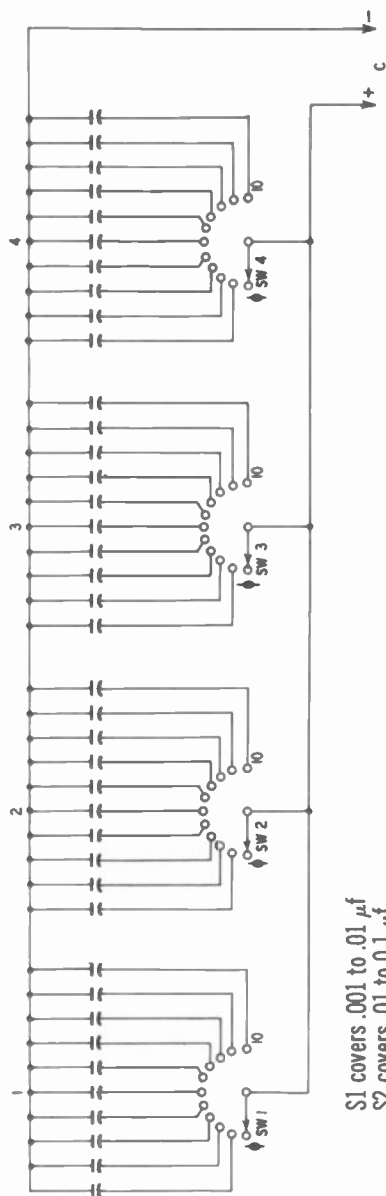

S1 covers .001 to .01 μf
 S2 covers .01 to 0.1 μf
 S3 covers .1 to 1 μf
 S4 covers 1 to 10 μf

Position 10 (all switches) results in 11.11 μf

To obtain higher values of capacitance additional decades can be added. The values of capacitance for each position increase arithmetically.

Capacitors are paralleled to obtain odd values.

Fig. 307. Typical setup for a capacitance decade unit. Values of individual capacitors are not given since these will vary, depending upon the manufacturer. Each switch is operated individually. Capacitance values supplied by these instruments cover practically the entire range normally encountered in servicing transistor receivers.

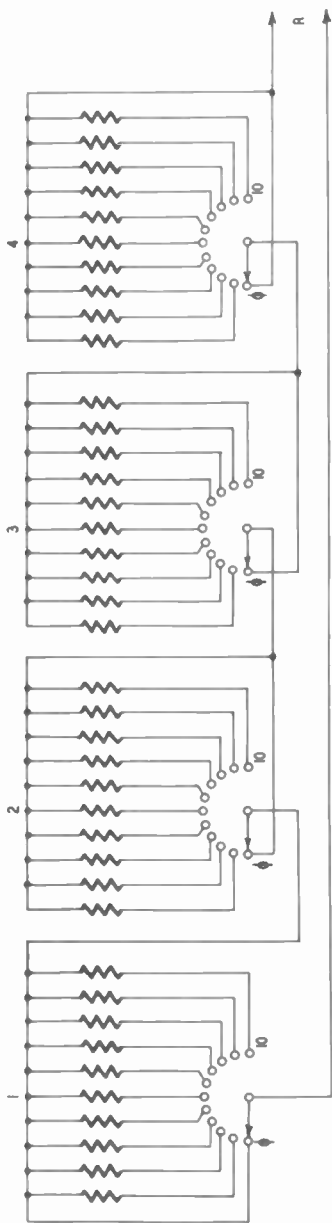

Fig. 308. Resistor decade substitution box.
The four switches permit selection of resistance values most commonly required in servicing.

- S1 covers 1 to 10 ohms
- S2 covers 10 to 100 ohms
- S3 covers 100 to 1,000 ohms
- S4 covers 1,000 to 10,000 ohms
- Position 0 produces 0 ohms

To obtain higher values of resistance additional decades may be added. The values of resistance increase arithmetically (that is, 1, 2, 3, 4 etc.).

Resistors are placed in series to obtain odd values.

tenna circuit, the station to which the antenna circuit is tuned should be heard clearly in the tracer's speaker. Fig. 310 is the schematic of a simple transistor signal tracer. Fig. 311 shows the

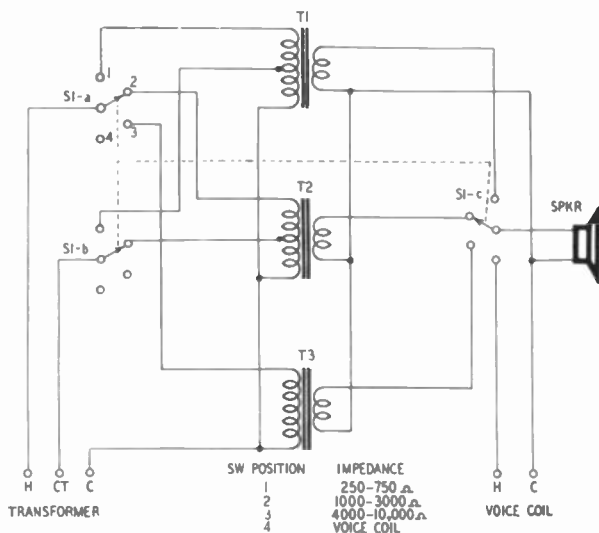

Transformers: T1—primary, 500-ohms ct; secondary, 3.2 ohms [Argonne AR-119 or equivalent]; T2—primary, 4,000 ohms ct; secondary, 8 ohms [Argonne AR-134 or equivalent]; T3—primary, 10,000 ohms; secondary, 8 ohms [Argonne AR-132 or equivalent]
Speaker: 3.2 ohm PM
Miscellaneous: S1-a, -b, -c—three pole, four position rotary switch

Fig. 309. Schematic of substitute speaker.

constructional details of the rf probe. The entire unit, including the speaker, can be built into a cigar box.

Transistor power supply

Although not an absolute necessity, it is a handy item to have in the shop. It helps to conserve batteries when testing or operating transistor radios over long periods of time.

Fig. 312 shows the schematic of a transistor power supply. It is capable of providing regulated voltages from 4 to 12 volts, at currents up to 200 ma. It should take care of the power requirements of just about all the transistor radios presently on the market. For those sets that require a higher supply voltage or current than that provided by this supply, the use of heavy-duty batteries is recommended.

In constructing this power supply, all components should be

mounted on an aluminum chassis. Aluminum is used because of its good heat-dissipating properties, the chassis acting as a heat sink for the power transistor. Since the collector is bonded to the case for heat dissipation, the case of the power transistor should be electrically insulated from the chassis (Fig. 313). Mica washers or other heat-conducting electric insulators can be used between the

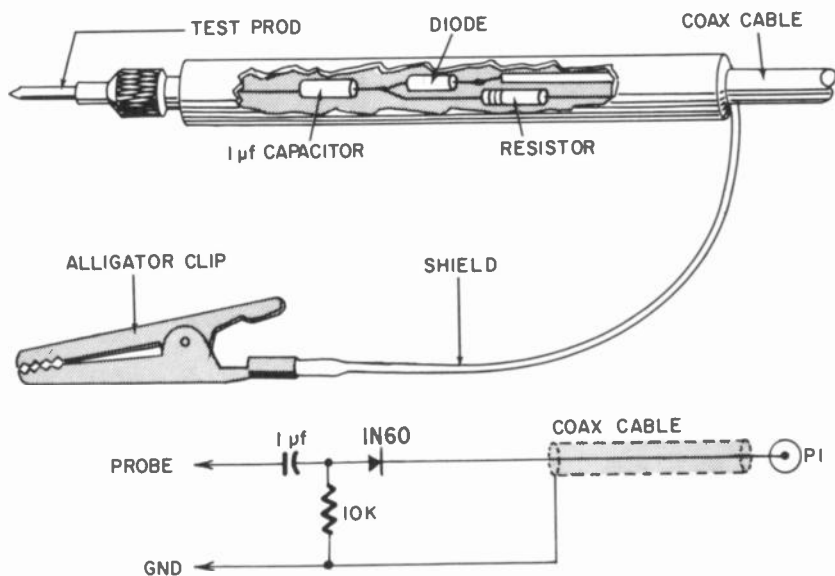

Fig. 311. Rf probe for the signal tracer shown in the preceding illustration.

transistor case and the chassis. After mounting, the transistor case should be checked to see that it is not connected electrically to the chassis. This can be done with an ohmmeter.

An alternate method of mounting the transistor is shown in Fig. 314. Here the transistor is bolted directly to a heat sink. The sink is then insulated from the chassis by insulated standoffs or rubber mounting grommets. An electrical connection to the transistor is made through the heat sink. Construction details of the heat sink are shown in Fig. 315.

Component substitution

With the many miniature and special parts used in various models of transistor radios, it is next to impossible to keep a complete replacement stock on hand. The cost would be excessive and the turnover would not be high enough to warrant keeping this

inventory. Many times, too, local distributors may not have the required parts available. This makes it necessary to contact the

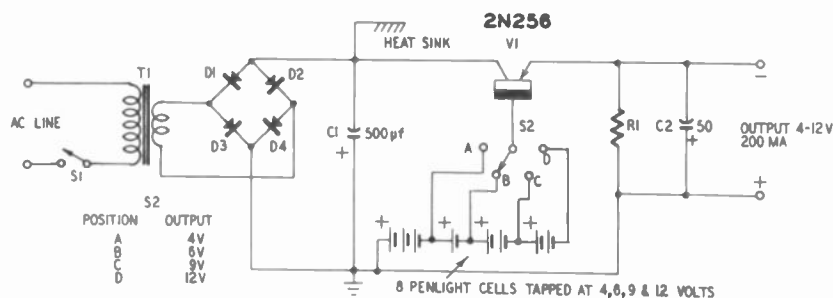

Resistor: R1—10,000 ohms, 1 watt
 Capacitors: C1—500- μ f 50-volt electrolytic;
 C2—50- μ f 50-volt electrolytic
 Transformer: T1—filament transformer [Stan-
 cor P-6469 or equivalent]
 Transistor: V1—2N256 audio power

Diodes: D1, D2, D3, D4—1N91, germanium
 Miscellaneous: S1—sps toggle; S2—single
 pole, four position rotary; B—8 penlight
 cells connected in series, tapped at 3, 6,
 9 and 12 volts

Fig. 312. Transistor substitute power supply.

manufacturer and obtain the parts directly; a process that can take many weeks.

All this leads to a practice common in the service shop; substituting one type of part for another. Many times you can replace one tube with another in a radio or TV set and get satisfactory re-

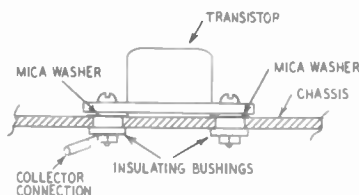

Fig. 313. Method of mounting and insulating power transistor on chassis.

sults, even though the tubes may not have the same number. Because they are voltage operated devices working at relatively high levels such substitutions will frequently be used in a vacuum-tube receiver. However, when working with currents in the order of microamperes and milliamperes, a slight variation is significant.

This is true, even though the specifications for different transistors may seem remarkably similar.

Other components can be critical too. As an example, let us assume that you have a transistor radio in which the primary winding of an if transformer has opened and that the transformer cannot be repaired but must be replaced. A quick check of your stock shows that you do not have this part but that you do have

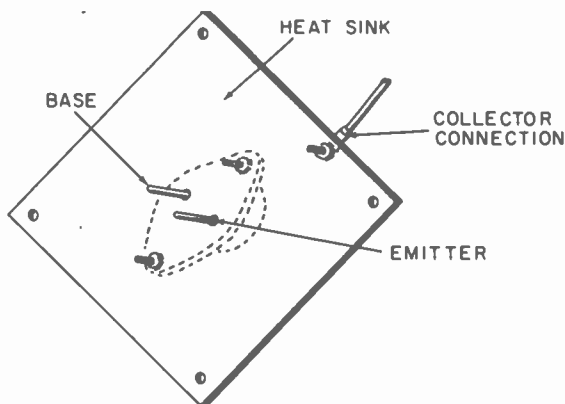

Fig. 314. *Mounting the transistor to a separate heat sink.*

one used in another make of set. The replacement is the same size and shape and its terminals are arranged in a similar manner. Although mechanically identical, the impedance and dc resistance of the windings are much lower than those of the original. The urge to use it may be very strong, but if you do you'll have a damaged radio on your hands.

The reason for the lack of good performance is simple. Because of the low impedance, alternating currents increase. The direct currents increase because of the low dc resistance. The operating point shifts. The base current increases and any one of several changes will cause the collector current to rise past the safe maximum limit. Any of these changes affect the gain of the stage involved, lowering the overall performance of the receiver. And finally, the transistor can also burn out.

Some other practices that can result in irreparable damage include substituting an n-p-n transistor for a p-n-p unit (the substitute transistor will be damaged or destroyed); substituting transistor types, substituting a different value of resistance or capacitance for the required value, and so on.

It is impossible to present here a list or chart of interchangeable parts. The selection must be left to the knowledge and ingenuity of the service technician. The important thing to remember is to

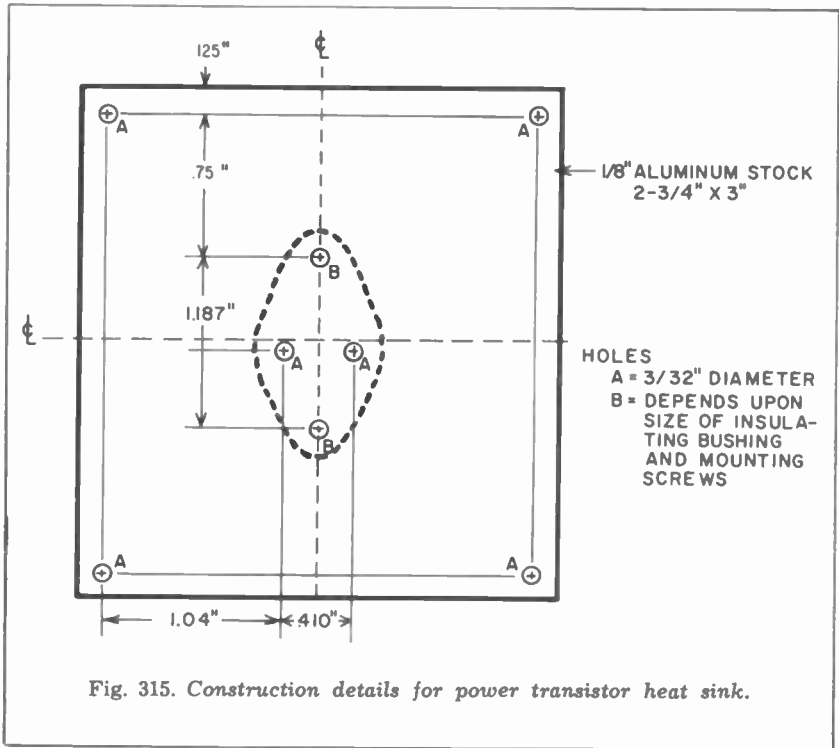

Fig. 315. Construction details for power transistor heat sink.

compare the specifications of the substitute with those of the original before any attempt is made to use it.

Printed circuits

Wiring circuits by printing the conductor pattern, and in some cases the components, makes possible neat and compact electronic equipment. Printed circuitry is used extensively in transistor radios, and a basic knowledge of the fundamentals of such wiring is a must.

Many processes have been, and are being, devised and developed to produce printed circuits. The most commonly used is the etch-foil process. A conductor pattern is printed with a special ink, called resist ink, on a copper-clad laminate board. After printing, this board is placed in a heated solution of ferric chloride which etches, or dissolves, all the copper not covered by the ink. When

the last traces of the uncovered copper disappear, the board is removed from the solution. It is then washed in water, cleaned of the ink, and drilled or punched. Component parts are then assembled on the board and soldered. A step-by-step illustration of this process is shown in Fig. 316.

High-quality printing of the conductor pattern on the copper laminate is necessary so that complete coverage is given and no pinholes or breaks appear in the conductor lines. This can be

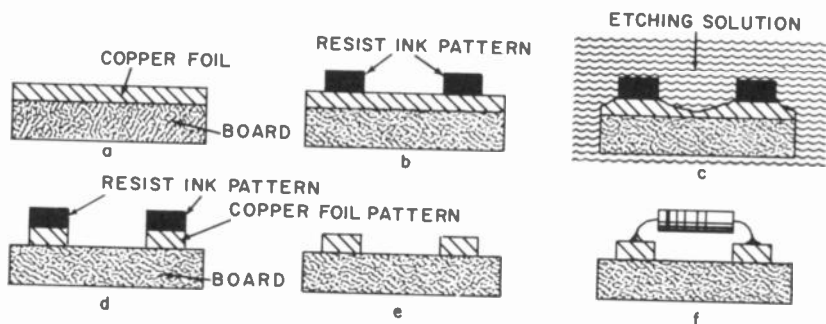

Figs. 316-a to f. Printed circuits produced by the "etch-foil" process. (a) Copper laminate board. (b) Application of resist ink pattern. (c) Etching of copper foil. (d) Etching complete. (e) Resist ink removed. (f) Component part mounted and soldered.

achieved by using the silk-screen process or the photo-offset method. The silk-screen process makes use of the resist-ink.

In the photo-offset method, the copper laminate is coated with a light-sensitive emulsion. A transparent negative of the conductor pattern is placed over the laminate and the whole unit is exposed to intense ultra-violet light. After exposure, the board is placed in a developing solution which hardens the exposed area and dissolves the unexposed emulsion. The developer is then washed off the board, and the board is placed in the etching solution. From here on the process is the same as that used with the resist ink. Fig. 317 shows this process, step by step.

The copper-clad laminate in the etch-foil process is available in several grades. Either cloth, paper, glass cloth or fibrous glass is generally used as the base material. These are impregnated with a phenol or other resin under heat and pressure to form a rigid sheet. The paper-base laminate is the most commonly used. Laminates are classified in grades XP, XXP and XXXP, the latter having the lowest dielectric losses and highest surface resistance.

Other materials, such as Nylon, Orlon, Dacron, Teflon, etc. are also used for base materials. Each has its specific use and advantage in printed circuitry. The Teflon-base laminate is especially interesting since it can be used in circuits operating at frequencies of 8,000 mc. Only its high cost prevents it from being used in all applications.

After the laminate has been made, it is clad on one or both sides with copper foil, whose thickness can range from .001 to .005 inch.

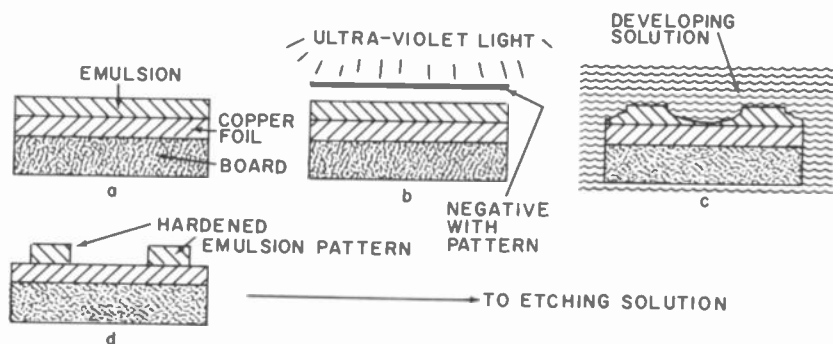

Figs. 317-a to d. Printed circuit produced by the "photo-offset" method. (a) Copper laminate board with emulsion applied. (b) Pattern negative placed over emulsion and exposed to ultra-violet light. (c) Exposed board placed in developing solution. (d) Developing complete. Etching of copper is the same as in Fig. 316.

depending upon its intended application. This foil is bonded to the laminate under heat and pressure. Unless the laminate is made of good bonding material, a bonding agent is used to attach the copper foil.

Printed-circuit repair

The printed-circuit board itself rarely, if ever, becomes defective. The only time servicing or repair is required is when one or more of the components on the board fail to function. A resistor can change value or burn out; a capacitor may become leaky or shorted; an if transformer winding may open. These components are easily replaced if the proper methods are used.

Replacing defective components without removing the printed-circuit board from its mounts can be accomplished by one of the following techniques:

If the extending leads on the defective components are long enough for a replacement to be soldered to them, these leads can be cut where they go into the defective component body (see Fig. 318). The leads are then straightened and a small loop made at

their ends. The leads from the new component are cut to size and the ends also fashioned into loops as shown in Fig. 319. These leads are then coupled together, crimped and soldered with a 60/40 solder.

When the extending leads from the defective component are

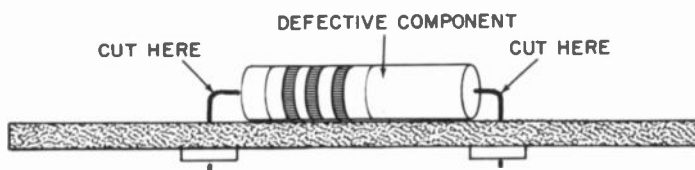
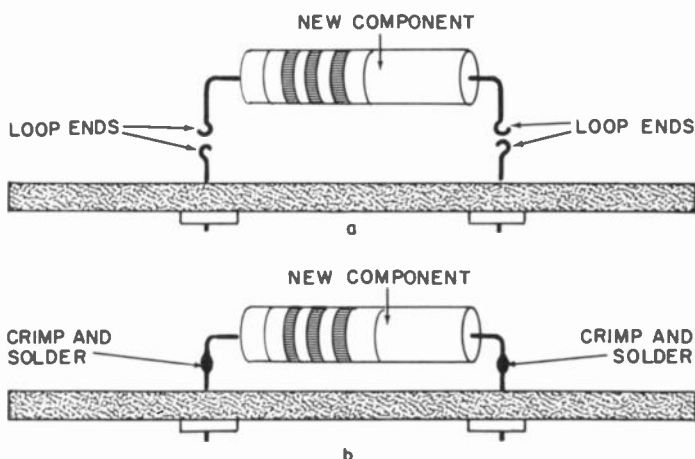

Fig. 318. Cutting leads of defective component.

too short, the component can be cut in half with a pair of diagonal side cutters. The extra lead within the destroyed component can be used in the manner just described.



Figs. 319-a, -b. Method of mounting a new component.

If the component has to be removed from the printed-circuit board, then the board itself must be removed from its mount. Using a small soldering iron, heat the connection on the wired side of the board. As soon as the solder melts, brush it away with a small stiff-bristle or small wire brush. Be careful not to overheat the connection. Reapply the soldering iron and quickly pull away the component lead. Do this first with one lead and then the other.

In some cases this process may have to be repeated a few times to remove the solder completely. If the component lead has been bent over, insert a thin knifeblade between the lead and the conductor and then straighten the lead.

After the component has been removed, clean the mounting

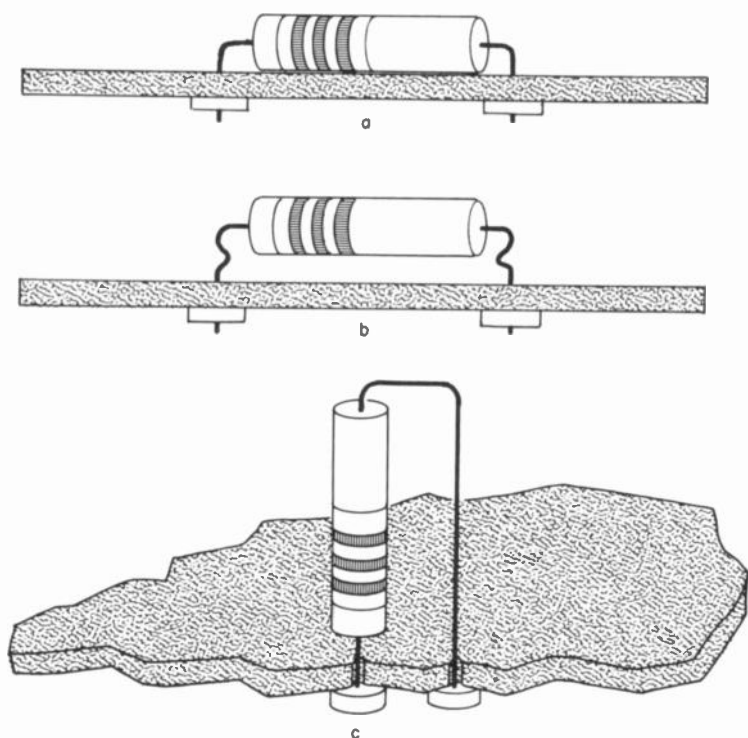

Figs. 320-a, -b, -c. Three methods of mounting axial lead components to a printed circuit board.

holes of all solder by melting the solder and brushing it away. Or, melt the solder and blow it out of the hole while it is liquid. Mount the new component in place by inserting the leads in the holes and resolder with 60/40 solder. The different methods of mounting axial-lead components, such as resistors and capacitors, are shown in Fig. 320.

In removing or replacing multitab components (if transformers, oscillator coils, etc.), the operation is the same. First apply the soldering iron, then brush away all solder. After the removal of the solder from the joints, wiggle the component gently to be sure

that all connections are broken. If not, repeat the solder-removal process. When the joint is clear and has cooled, a gentle but firm rocking motion of the component should release it from the board.

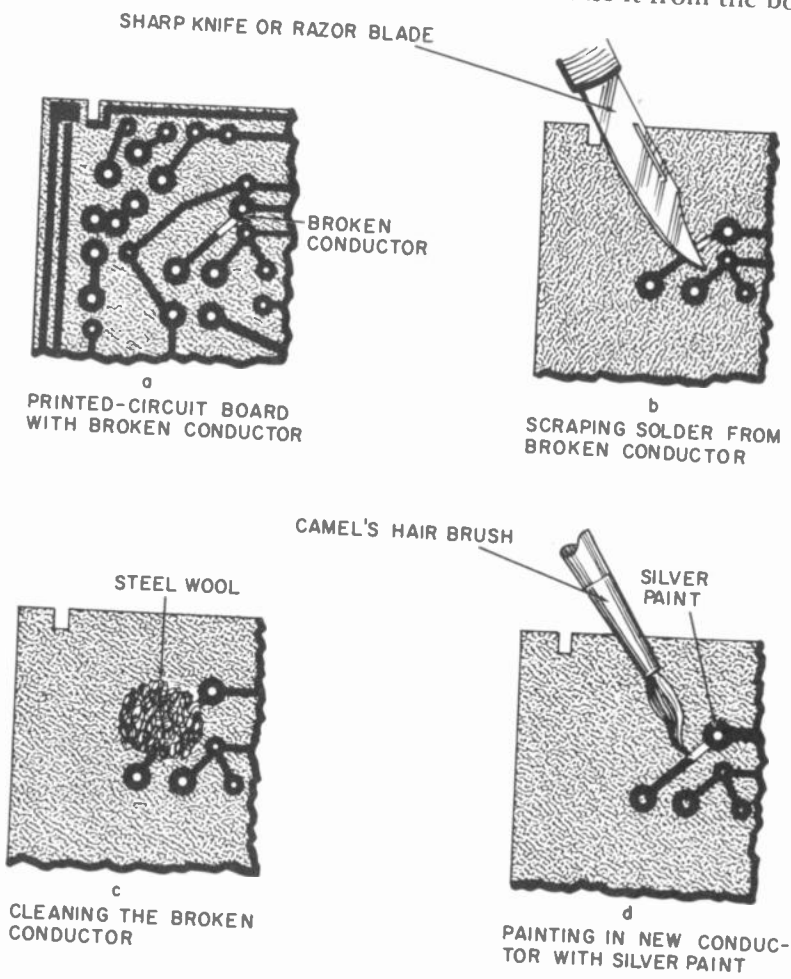

Figs. 321-a to d. Steps in repairing a broken conductor on a printed-circuit board.

Do not apply force to the joint while doing this. Any force can, and usually does, damage the printed conductor or the board.

After the component has been removed, clean the mounting holes of all solder. Insert the new component in place, and solder. When replacing multitable components with symmetrical tab spacing the service technician must make certain that the component is

not placed 90° to 180° out of position. Mark the board, for proper positioning, *before* the old component is removed to avoid this type of error.

Sometimes, when removing a component from a printed-circuit board, too much heat is applied to the conductor. This heat destroys the bonding agent and causes the conductor to peel from the board. Once this peeling takes place, the conductor cannot be returned and kept in its original position. Using cement to hold it in place does not help because, as soon as resoldering takes place,

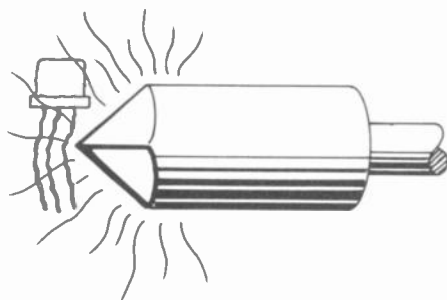

Fig. 322. Do not use a high-wattage soldering iron for soldering transistor leads.

the cement is destroyed. The only solution is to let the component itself hold the conductor in place. A coating of shellac or lacquer after resoldering helps to protect the damaged portion.

Where the conductor has peeled and broken off, replacing it with a wire jumper is impossible. The heat of soldering will only increase the damage by causing further peeling. The solution is to use silver conducting paint to form a new conductor. With a sharp knife or razor blade clean all of the solder from about $\frac{1}{8}$ inch of the remaining conductor. Scrape away carefully until the copper is reached, and then use steel wool to finish the job.

Mount the component in place and solder it to the terminals to keep it from moving. Using silver conducting paint, draw a line from the cleaned conductor to the terminal. Paint around and over the terminal and over the conductor. Keep applying the paint building up layers of silver until the resistance of this new conductor is of the same value as a similar portion of the copper conductor. This operation is shown, step by step, in Fig. 321.

To repair printed circuits, you will need these tools and materials: Pencil iron (25 to 30 watts); pair of tweezers; stiff-bristle or

wire brush; sharp knife or razor blade; pad of steel wool; camel's hair brush (small, soft); lettering pen, with $\frac{1}{16}$ -inch wide nib; one

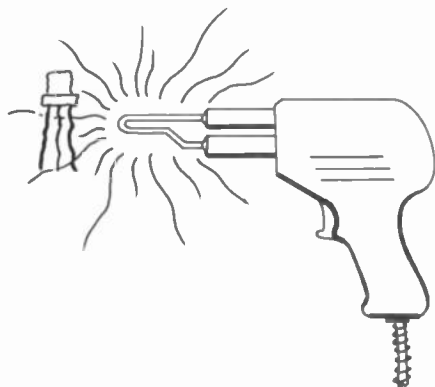

Fig. 323. Do not use a soldering gun near a transistor.

ounce of silver conducting paint; solvent and a supply of 60/40 solder.

Servicing precautions

As in the servicing of vacuum-tube radios, there are certain

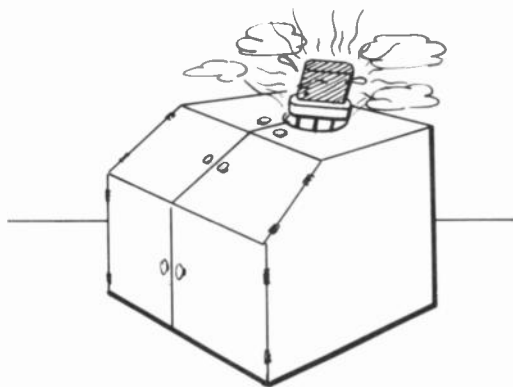

Fig. 324. Do not subject transistors to high heat.

precautions that must be observed when repairing transistor sets. Listed here are the basic and most important ones. Adhering to them will prevent serious and costly damages and will help save servicing time.

(a) When soldering or unsoldering transistor leads, use a pair of long-nose pliers to hold the leads. The pliers act as a heat sink and will prevent damage to the transistor.

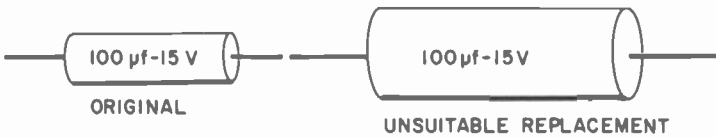

Fig. 325. When replacing components, use exact replacement types.

(b) Do not use a high-wattage soldering iron for soldering to or removing transistor or component leads from a printed-circuit board (Fig. 322).

(c) Do not use a soldering gun near a transistor. The electromagnetic field developed can destroy the transistor by inducing high alternating currents in it (Fig. 323).

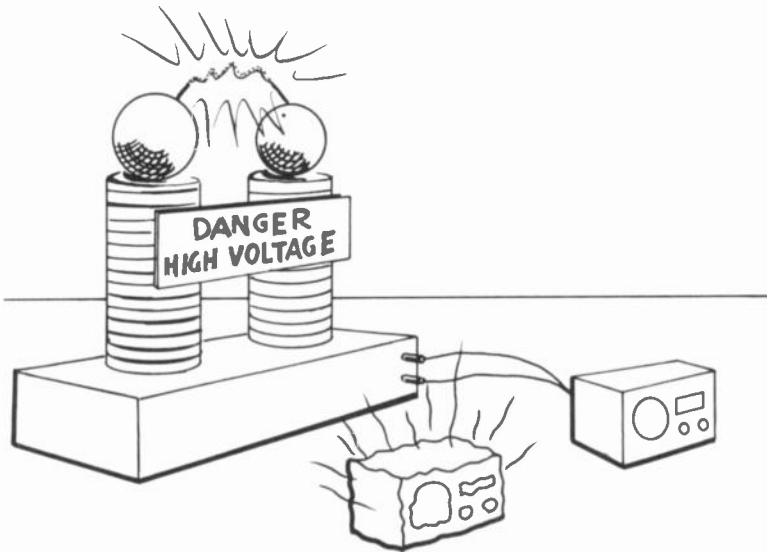

Fig. 326. Do not exceed the supply voltage requirements of the radio when substituting for or replacing the battery.

(d) Do use a small pencil type iron (about 25 watts) when soldering or unsoldering transistors or components to a printed-circuit board.

(e) Do not subject transistors, components or printed-circuit boards to unnecessary high or *prolonged* heat (Fig. 324).

(f) Before replacing a transistor, be certain that it is of the

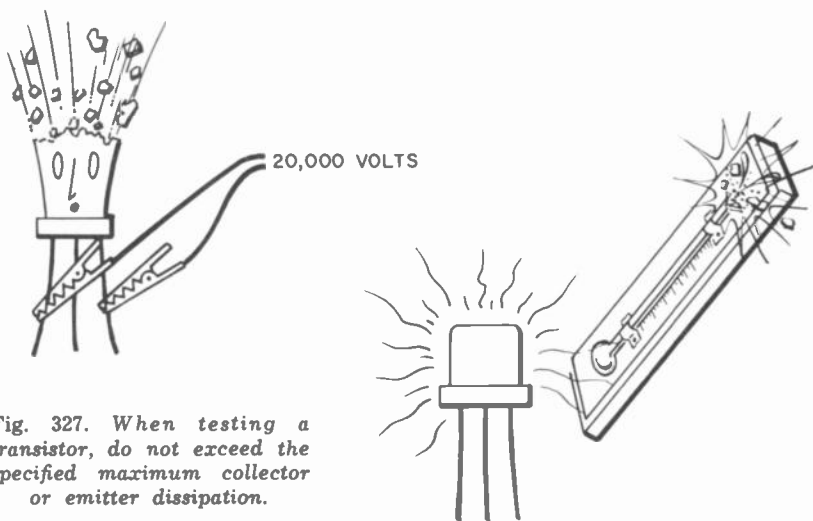

Fig. 327. When testing a transistor, do not exceed the specified maximum collector or emitter dissipation.

same type as the one being replaced, that is, the same type number and same class (p-n-p or n-p-n).

(g) When replacing a transistor, make certain that it is placed in the circuit properly, base in base circuit, etc.

(h) When replacing components, use exact replacements or types whose electrical characteristics are identical to the component being replaced (Fig. 325).

(i) Always observe polarity when replacing electrolytic capacitors. If reversed many of the miniature types will act as a short circuit.

(j) Observe polarity when replacing batteries.

(k) Do not exceed the supply voltage requirements of the radio when substituting the battery (Fig. 326).

(l) Do not change values of components to improve the performance of the radio.

(m) Do not change or alter circuits to improve the performance of the radio, unless recommended by the manufacturer.

(n) Do not operate transistors or transistor radios next to hot objects.

(o) When testing a transistor, do not exceed the specified maximum collector or emitter dissipation (Fig. 327).

(p) When checking the resistances of circuit components

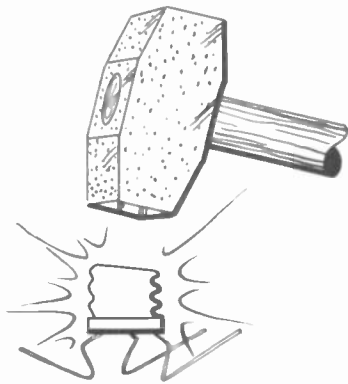

Fig. 328. Do not subject the transistor to extreme mechanical shock.

be sure to remove the transistor. If this is not possible, use a low voltage low current ohmmeter, preferably of the electronic type often included in a vtm.

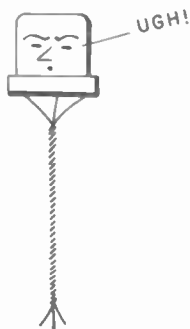

Fig. 329. Do not twist leads excessively.

(q) When disabling a stage for test purposes, remove the transistor.

(r) Do not short or shunt any components for the purpose of testing.

(s) When substituting components, remove the suspected defective component from the circuit first.

(t) Do not insert a transistor into a circuit while power is applied.

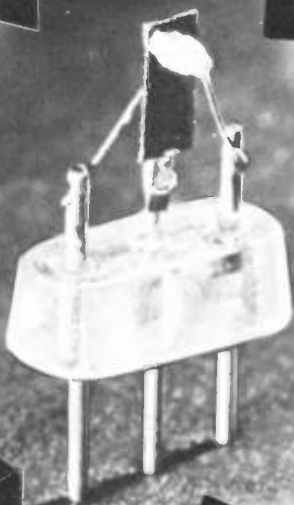
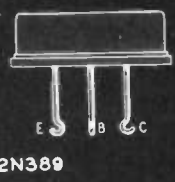
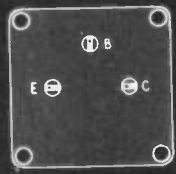
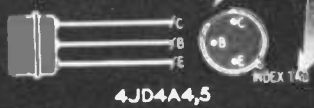
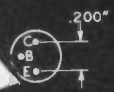
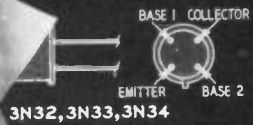
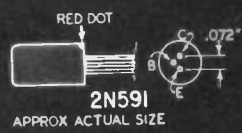
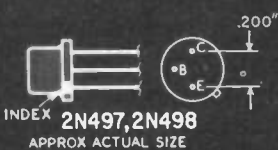
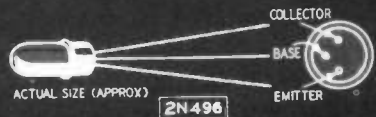
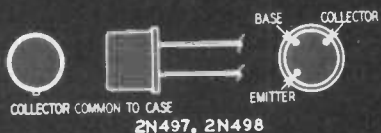

servicing transistor radios

As in vacuum-tube portable radios, whenever a transistor radio is brought into the shop for repairs, the first thing to do is to check the battery voltage under load. It is surprising to see how many troubles are caused by a weak battery (troubles such as fading, drift, distortion, poor sensitivity, low audio output, motor-boating, etc.). Of all the transistor radios that have been brought into the service shop for repairs, it was found that approximately 80% of them required just a battery change.

If the battery voltage registers normal under load (within limits), or replacing it does not cure the trouble, then one or more of the procedures previously described should be used to locate the cause of improper operation. The best time-proven method of troubleshooting is to check each stage individually, starting with the audio output stage and working back toward the converter.

For example, you have been given a radio to repair, with the complaint that it is "dead." You wouldn't set to work immediately to repair the converter (unless the trouble is obvious) when the audio output stage is at fault. The thing to do is to start your search with the audio output stage first, confirm performance, and work your way back toward the converter, stage by stage, until the malfunction is found.

Unfortunately, transistors cannot be removed from the radio and inserted into a tester to find which one may be defective for in most cases they are soldered into the circuit. Also, at present, there isn't a transistor tester on the market (within the service

technician's financial reach) that will give a true and complete picture of the transistor's dynamic performance. The testers that are available operate in somewhat the same fashion as the emission testers that are used to check vacuum tubes. All these testers tell you is whether or not current is flowing through the transistor. A perfect example to illustrate this point is a type 2N112 transistor about which the author was dubious. It was inserted in one of the available transistor testers which showed that the collector current was rather high. This meant that the transistor was not too good. But, upon inserting it into a test circuit, it proved to be a better

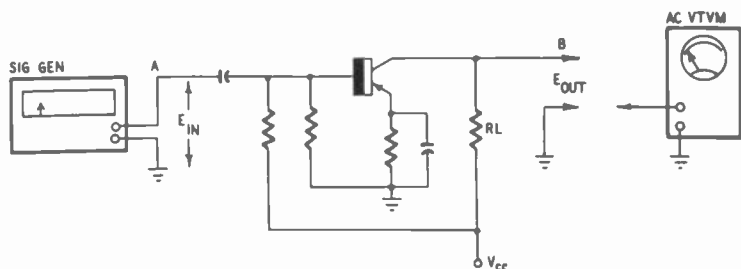

Fig. 401. Method for determining the condition of a suspected defective transistor. Use the ac vtvm to measure generator and transistor amplifier output.

transistor than a brand-new unit whose collector current was low. Both the alpha and beta of this "defective" transistor measured low but, when placed in a dynamic tester, proved to be on the high side of the manufacturer's design center.

You may say that the tester wasn't any good or that the transistor wasn't measured properly. But, when more than three different-make testers are used and give the same results, what then? These testers are good and serve their purpose, but they should not be used as the final authority in determining the worth of a transistor, unless the readings you obtain definitely indicate that it is defective.

To determine the condition of a suspected defective¹ transistor, without removing it from the circuit, it is necessary to have on hand a signal generator and an ac vtvm. Connect the generator, as shown in Fig. 401, to the input of the suspected defective transistor. When the transistor to be tested is connected in an

¹The word defective is often interpreted by manufacturers as pertaining to those components which break down due to slight deviations or faults in manufacturing procedure. However, as used in this book, the word is intended to describe any component which has failed, no matter what the cause.

audio amplifier use the audio-output connection of the generator. For most test instruments this will be 400 cycles. This frequency is somewhat low, but since the 400-cycle voltage of many generators is not a pure sine wave, there will be enough harmonics to

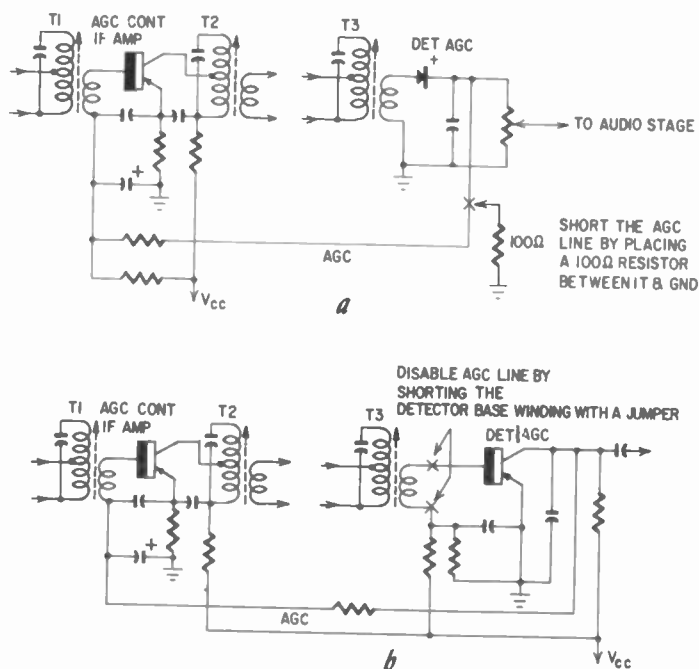

Figs. 402-a, -b. Techniques for disabling the automatic gain control (agc) network. (a) Transistor circuit using a diode detector. (b) This circuit uses a transistor detector.

make the test a valid one. If you have an audio generator use it and adjust the frequency control for a reading of 1,000 cycles. Set the output level of the generator to approximately .01 volt, as indicated by the ac vtvm, and measure the output voltage of the stage between the collector and ground. The voltage gain of the transistor should be at least equal to the beta of the transistor, $\pm 10\%$. When measuring the gain of an rf or if stage, disable the agc line so that it will not have any effect upon the gain of the stage. The method of disabling the agc line is shown in Fig. 402. The technique for eliminating the agc voltage is governed by the type of detector that is used. In Fig. 402-a, for example, the agc voltage is effectively grounded by connecting a 100-ohm resistor in shunt with the diode load. In Fig. 402-b the agc line is disabled

by shorting the detector base winding. The frequency of the signal generator should be set to the range in which the transistor normally operates.

Receiver test points

In the schematic of Fig. 403, the logical test points in a transistor radio are shown. By using either signal-tracing or signal-substitution methods, the service technician can quickly and easily isolate trouble. A good place to start, using the signal-tracing method, is between the detector and audio amplifier (point A). A signal at this point indicates that the trouble lies somewhere between this point and the speaker. If no signal is present here,

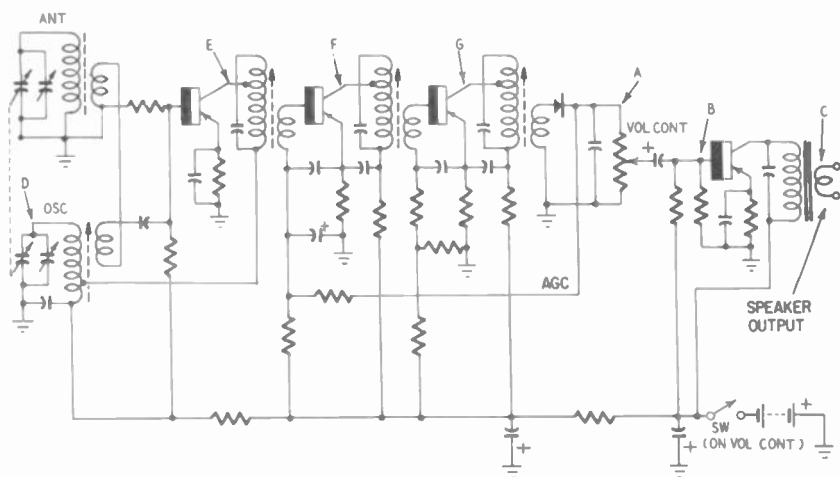

Fig. 403. Test points in a typical transistor radio. Many service technicians start probing at point A as a first rough guide toward localizing the trouble.

then the trouble lies between the antenna circuit and the detector. Additional test points, in either direction, would be B and C or D and E.

Reducing the number of circuits to be tested by half, as in this method, has the advantage that with one check you can tell in which portion of the receiver the fault occurs. Of course, when injecting a signal into the various test points it is necessary to use the proper generator impedances (this can be quickly determined by referring to the transistor characteristics sheet), frequency and signal amplitude. For audio tests at points A, B and C, a frequency of 400 cycles can be used. For points E and F, the receiver intermediate frequency should be used with 400-cycle modulation.

At point D, any frequency within the tuning range of the receiver can be used.

Although the purpose of automatic gain control is to maintain constant the carrier voltage present at the second detector, regardless of signal strength, its action is one of the major differences that is encountered in transistor radios. Circuits that use n-p-n transistors in the rf circuits have terminal voltages that are, with respect to one another, just about the same as in a vacuum-tube radio. As the signal increases, the agc voltage also increases (negatively). Since it is applied to the base of the controlled stage, the transistor gain drops. In circuits that use p-n-p transistors in the rf section, the polarity of the terminals is reversed as is the agc voltage. The action is the same, though the voltage increases in

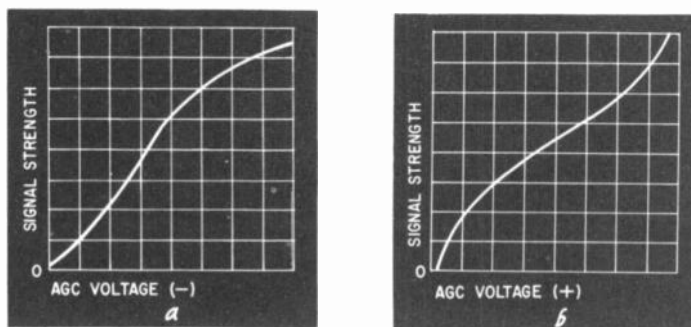

Figs. 404-a, -b. Differences of agc voltages. (a) Using n-p-n transistors. (b) Using p-n-p transistors.

a positive direction. This difference between the agc voltages is shown in Fig. 404.

In spite of this difference in polarity, a dc vvm connected to the agc line to read upscale will show variations in voltage as the receiver is tuned to different signals. This gives us another quick method of testing to show whether or not the radio is functioning up to at least the second detector.

If, after using either the signal-tracing or signal-substitution method, there is evidence that there is a break in the signal path, then the if transformers should be checked and aligned. If the if stages are functioning properly, then the most probable cause of the trouble lies in the local oscillator or converter circuit.

Most typical troubles, such as poor sensitivity at either the low or high end of the band, one station tuning over the entire range, heterodyning when tuning, cutout at the high-frequency end of

the band, etc., can be attributed to the mixer, local oscillator or converter stage. A defective transistor can cause poor sensitivity while an open emitter bypass capacitor can cause cutoff. A broken antenna core can cause heterodyning (squealing when a station is approached), while an open antenna coil primary winding can cause a squeal over the entire tuning range.

Weak signals, distortion on strong signals, squeals and noise are usually caused by malfunctioning components or transistors in the if stages. A trouble such as squeals, even after the oscillator

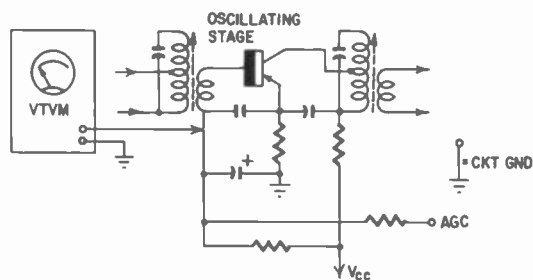

Fig. 405. A dc vacuum-tube voltmeter can be used to check for oscillation in the intermediate-frequency amplifier.

is disabled, is ordinarily caused by oscillation in the if stages. This in turn is most often caused by a defective neutralizing capacitor, resistor or misalignment. Replacement of either or both of the neutralizing components or realignment of the stages will remove this trouble. A quick method of checking for oscillation is to measure the base voltage with respect to the circuit ground (Fig. 405). If the base voltage measures positive when using p-n-p transistors, or negative using n-p-n units, then the stage is oscillating. By a process of elimination, the offending stage can be found and serviced. Sometimes both stages may be oscillating, with the output of the second stage feeding back to the input of the first. In this case, the electrolytic filter capacitor in the agc line (Fig. 406) is open. The feedback path is as shown by the arrows.

Distortion

When there is distortion of the audio signal on all stations or motorboating, then the troubles can most often be blamed on the audio section. This distortion can be caused by a defective speaker, a shorted emitter bypass capacitor or a defective transistor. The fault can be found by using a signal tracer and audio generator

(Fig. 407). Measuring the voltage across the emitter resistor of the audio driver stage will tell you whether the emitter bypass capacitor is shorted (the emitter will be at ground potential). An open

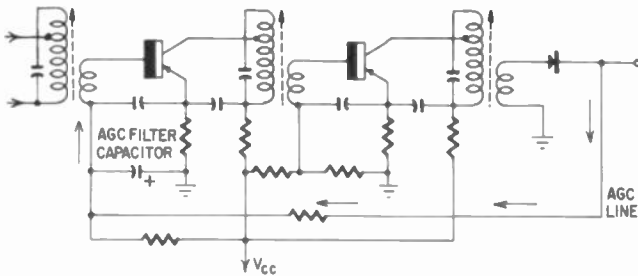

Fig. 406. Location of the agc filter capacitor and the feedback path that causes oscillation in the if stages when the filter capacitor is open.

collector decoupling capacitor (where used) or an open collector filter capacitor will cause motorboating.

If distortion occurs on strong signals only, then the trouble usually lies in the agc circuit. A shorted bypass or filter capacitor

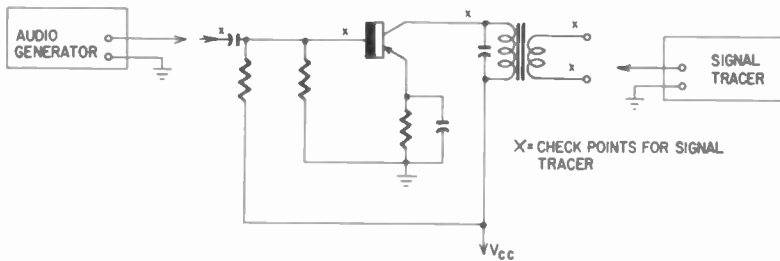

Fig. 407. Using the audio generator and signal tracer to check for distortion in the audio stage(s).

is almost always at fault. A defective detector will also cause distortion on strong signals since the agc voltage developed cannot rise to a value that is high enough to reduce the gain of the controlled stages and compensate for the overload.

A systematic method of search is required to find the defect, or defects, in a transistor radio but it is time consuming. The service technician can ill-afford to spend service time on a radio beyond that which has been estimated or allotted.

Typical troubles and their causes are listed here for each stage. A quick-check method of testing is included to determine immediately whether a suspected stage is functioning normally.

Mixer stage, converter stage, local oscillator

Quick check: Tune the radio to 600 kc. Couple the signal generator to the antenna coil (Fig. 408) and rotate the signal generator dial through 600 kc. Modulation should be heard in the

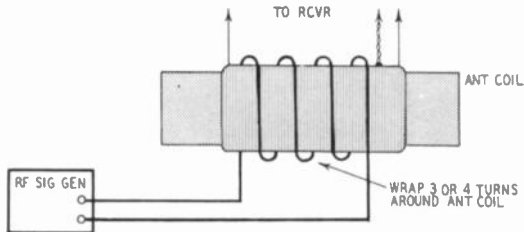

Fig. 408. Method of coupling the signal generator to the receiver.

speaker if the stage is functioning. To double check, repeat the procedure at 1,500 kc.

Symptom

Cause

Poor sensitivity at the low-frequency end

Defective mixer or converter transistor
Misadjustment of the oscillator coil

Poor sensitivity at the high-frequency end

Defective mixer, oscillator or converter transistor
Broken or cracked antenna coil core
Misalignment of the antenna tuning circuit

Cutout at the high-frequency end of tuning range

Open emitter bypass capacitor
Defective oscillator or converter transistor
Misalignment of the antenna tuning circuit
Misalignment of the if stages
Warped or shorting tuning capacitor plates

One station over the entire tuning range

Oscillator or converter not functioning
Misalignment of the if stages

Symptom	Cause
Cutout at the low-frequency end of the tuning range	Warped or shorted tuning capacitor plates Misadjustment of the oscillator coil
Noise on all stations	Dirt between plates of tuning capacitor Dirty wiper contacts on tuning capacitor Distorted (shorting) tuning capacitor plates Defective mixer or converter transistor
Inoperative	Shorted bypass capacitors Shorted mixer or converter base coupling capacitor Defective mixer, oscillator or converter transistor Open oscillator coil winding Change in value of base-bias resistors Open antenna coil primary winding
Heterodyne or squeal when tuning	Open antenna coil winding Cracked or broken antenna coil core

First if amplifier stage

Quick check: Apply a modulated if signal to the collector of the converter or mixer transistor (Fig. 409). The modulation should be heard in the speaker.

Symptom	Cause
Weak signal	Open base or collector bypass capacitor Misalignment of the if transformers Defective transistor Excessive agc voltage
No output signal	Open base winding; input if transformer

Symptom

No output signal

Cause

Open collector winding; output if transformer
Shorted base or collector bypass capacitor
Defective transistor

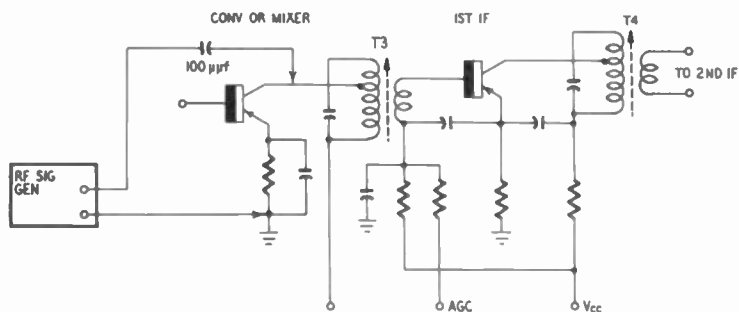

Fig. 409. Test setup to check the operation of the first if amplifier stage.

Distortion on strong signals

Low or no agc voltage
Low collector voltage
Defective transistor
Change in value of base-bias resistors

Noise

Corroded if transformer windings
Defective transistor

Oscillation (squeals)

Open neutralizing capacitor
Change in value of neutralizing capacitor or resistor
Open agc filter capacitor

Second if amplifier stage

Quick check: Apply a modulated if signal to the collector of the first if amplifier stage (Fig. 410). The modulation should be heard in the speaker.

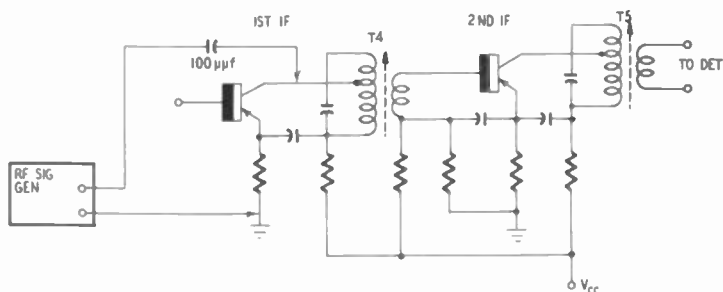

Fig. 410. Test setup to check the operation of the second if amplifier stage.

Symptom	Cause
Weak signal	Open base or collector bypass capacitor Misalignment of the if transformers Defective transistor
No output signal	Open base winding; input if transformer Open collector winding; output if transformer Shorted base or collector bypass capacitor Defective transistor
Noise	Corroded if transformer windings Defective transistor
Oscillation (squeals)	Open neutralizing capacitor Change in value of neutralizing capacitor or resistor

Reflex amplifier stage

Quick check: Apply a modulated if signal to the collector of the preceding stage. The modulation should be heard in the speaker (Fig. 411).

Symptom	Cause
Weak signal	Open base bypass capacitor Open emitter bypass capacitor Open rf choke

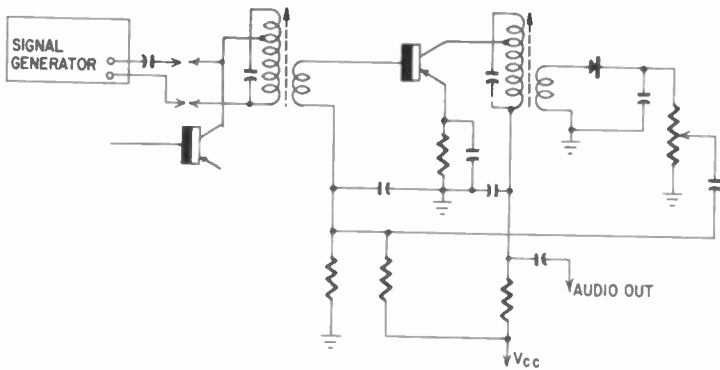

Fig. 411. Method for making a quick check of the if reflex amplifier.

Symptom	Cause
Weak signal	Defective rf bypass capacitor Defective transistor
No output signal	Defective af coupling capacitor Shorted base bypass capacitor Open af coupling capacitor Open base winding; input if transformer Defective transistor
Distortion	Open rf choke Shorted af coupling capacitor Shorted emitter bypass capacitor Change in value of base-bias resistors

Detector (diode)

Quick check: Apply a modulated if signal to the collector of the preceding stage (Fig. 412). The modulation should be heard in the speaker.

Symptom	Cause
Weak signal	Defective rf bypass capacitor Misalignment of if transformer Defective diode
No agc voltage	Defective diode

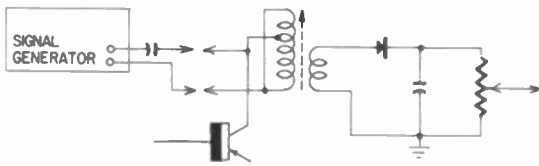

Fig. 412. Quick check of diode detector.

Symptom	Cause
Low agc voltage	Defective diode
	Open rf bypass capacitor
Distortion on strong signals	Shorted rf bypass capacitor
	Shorted agc filter capacitor
	Defective diode

Detector (transistor)

Quick check: Apply a modulated if signal to the collector of

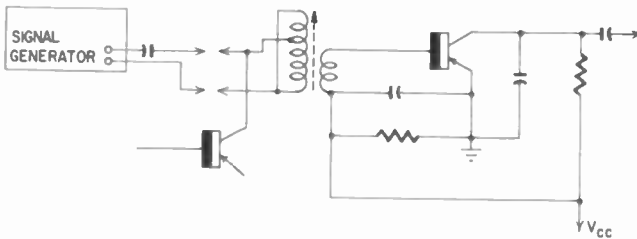

Fig. 413. Quick check of transistor detector.

the preceding stage (Fig. 413). The modulation should be heard in the speaker.

Symptom	Cause
Weak signal	Defective rf bypass capacitor
	Misalignment of if transformer
	Defective transistor
No agc voltage	Defective transistor
Distortion	Shorted coupling capacitor
	Defective transistor
Distortion on strong signals	Shorted rf bypass capacitor
	Shorted agc filter capacitor
	Defective transistor

Symptom
No output signal

Cause
Open coupling capacitor (only if agc voltage is present)
Shorted rf bypass capacitor
No collector voltage
Defective transistor

Audio driver stage

Quick check: Place a finger on the base terminal of the transistor. A hum should be heard in the speaker.

Symptom
No output signal

Cause
Open primary winding of the driver transformer
Shorted af bypass capacitor
No collector voltage
Defective transistor

Low output signal

Open emitter bypass capacitor
Low collector voltage
Defective transistor

Motorboating

Open decoupling capacitor

Distortion

Shorted emitter bypass capacitor
Change in value of base-bias resistors
Defective transistor

Audio output stage (class A)

Quick check: Connect an audio signal to the base of the transistor (Fig. 414). The audio should be heard in the speaker.

Symptom
No output signal

Cause
Defective speaker (open voice coil winding)
Open primary winding of the output transformer
Shorted af bypass capacitor
Open af coupling capacitor
Defective volume control
Contacts on earphone jack not making good connection

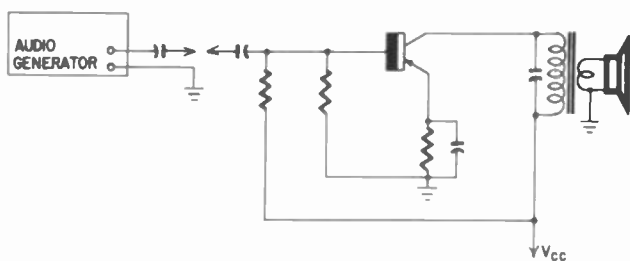

Fig. 414. Applying a signal to test the class-A audio output stage.

Symptom	Cause
Distortion	Defective speaker (voice coil rubbing against pole piece, or speaker cone torn) Shorted emitter bypass capacitor Increase in value of emitter resistor Defective transistor
Low output	Defective speaker (voice coil rubbing against pole piece) Defective transistor
Motorboating or squeal	Open supply filter capacitor Open collector decoupling capacitor

Audio output stage (class B)

Quick check: Connect an audio signal across the *base* winding (secondary) of the driver transformer (Fig. 415). The audio should be heard in the speaker.

Symptom	Cause
No output signal	Defective speaker (open voice coil winding) Open secondary winding of the driver transformer Open primary winding of the output transformer Shorted af bypass capacitor Contacts on earphone jack not making good connection Defective transistor (s)

Symptom	Cause
Distortion	Defective speaker (voice coil rubbing against pole piece, or speaker cone torn)
	Shorted turns in primary winding of output transformer
	Change in value of base-bias resistors
	Change in value of emitter resistor (s)
	Defective transistor (s)
Motorboating or squeal	Open collector supply filter capacitor
	Change in value of feedback resistor

NOTE: If a transistor is found to be defective in a class-B audio

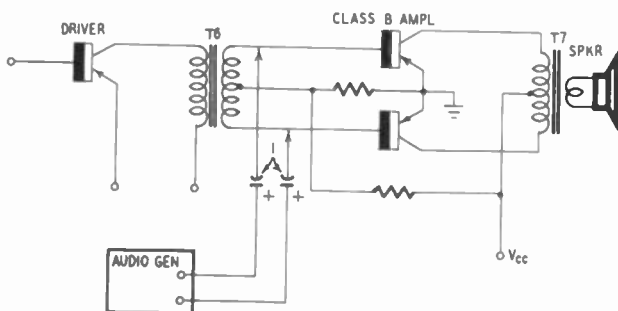

Fig. 415. Test setup to check the operation of a class-B audio output stage. (For automobile radios connect the test leads across the primary of the output transformer.)

output stage, the wise thing to do is to replace both transistors. These transistors are usually matched pairs and can be purchased as such.

Troubleshooting chart

To increase the speed of servicing transistor radios and to help save precious time, the most common troubles of transistor radios are listed for easy reference. You may come across a trouble that is not indicated but you will find that, in one way or another, it will be similar to the ones that are shown. With a little patience and fortitude you will be able to service and repair any transistor radio, regardless of what is wrong with it.

Symptom	Cause	Notes
Radio operates inter- mittently	Dirty switch contacts	
	Dirty volume control	
	Corroded battery terminals	
	Poor phone-jack contact	1
	Dirty tuning capacitor wiper contacts	
	Dirt between plates of tuning capacitor	
	Poor solder connections	2
Fades after short period of operation	Weak battery	
Station drift	Weak battery	
Heterodyning on all stations	Weak battery	
	Cracked or broken antenna coil core	
	Defective agc filter capaci- tor	
	Defective if neutralizing capacitor	3
Motorboating or squealing	Misalignment	
	Weak battery	
	Defective supply filter capacitor	4
Poor sensitivity at the low- frequency end	Defective audio de- coupling capacitor	
	Weak battery	
	Defective mixer or con- verter transistor	5
Poor sensitivity at the high- frequency end	Defective if transistor	5
	Defective mixer, converter or oscillator transistor	
	Misalignment of antenna circuit	5
Change in volume as radio is tuned to different stations	No agc voltage	
	Low agc voltage	

Symptom	Cause	
Change in volume as radio is tuned to different stations	Shorted agc filter capacitor	
	Shorted detector rf bypass capacitor	
	Defective diode detector	
	Defective transistor detector	
Low audio output	Weak battery	
	Defective detector	
	Defective audio transistor	
Distortion	Weak battery	
	Defective speaker	6
	Shorted af coupling capacitor	
	Shorted agc filter capacitor	
	Shorted emitter bypass capacitor	
Short battery life	Defective audio transistor	
	Defective switch	7
	Shorted or leaky supply filter capacitor	4
	Defective transistor	8

NOTES:

1. This is a common trouble in radios that provide for ear-phone reception. After some time and use, the jack contacts lose tension and do not make proper contact.
2. Even though dip soldering is used for connections on printed circuits, a few connections may not be properly soldered. It is best to examine all solder connections on the printed circuit board to prevent future troubles.
3. The value of this capacitor in most radios changes value with the slightest amount of heat. When replacing, use a zero-temperature-coefficient capacitor.
4. This capacitor is connected across the supply voltage to keep it fairly constant and to supply a low-impedance power source. Any change in value of this capacitor, or any leakage, will cause motorboating, squealing or short battery life. Its value is usually 100 μ f.
5. Poor sensitivity or weak reception may be due to any

number of things too numerous to mention here. The transistors listed are usually at fault. If not, only the substitution of components may reveal the cause of this trouble.

6. To determine if the speaker is defective, plug in the ear-phones (if there is provision for them) or use a substitute for the speaker. Set the volume control at mid-position and listen for distortion. If there is no distortion, then replace the speaker.
7. The switch does not open the circuit when the control is turned to the OFF position.
8. Usually the audio transistor is at fault, drawing excessive current even though seeming to be operating properly. Current for a class-A amplifier with 9 volts on the collector is about 4.5 ma; at 22.5 volts it is about 3 ma. For class-B amplifiers at 9 volts, the idling current is about 3 ma, peaking to about 40 ma.

Receiver alignment

When aligning the if stages in a vacuum-tube radio, the standard procedure is to disable the local oscillator (to prevent interference) and feed an if signal to the injector grid of the converter tube. This procedure does not hold true for transistor radios that do not have a separate oscillator. If you disable the oscillator, you disable the entire converter stage. It would then be necessary to inject an extremely strong signal into the radio to get any sort of indication. This may damage the converter transistor by causing it to draw excessive current and may lead to a false indication of alignment.

To align a transistor radio (where a separate oscillator is used it may be disabled without any effect), the signal generator should be loosely coupled to the antenna coil and the tuning capacitor set to a point on the dial where a station cannot be heard.

Connect a dc vtm to the agc line. Adjust the frequency of the signal generator to the intermediate frequency of the radio and set the output level so that the agc voltage is 0.5 volt above the no-signal value. Starting with the last if transformer and working toward the first, vary the slugs (or trimmers) for a maximum indication of agc voltage.

Reduce the signal generator output by one-half and repeak the slugs for maximum agc voltage. Repeat this procedure, reducing the generator output each time, until a point is reached where

adjusting the slugs no longer increases the agc voltage. This point then is the optimum for if alignment.

Sometimes when this point is reached, the radio will squeal or there will be heterodyning on each station that is tuned in. This is caused by oscillation of the if stages. Slightly detuning the second if transformer will clear this condition. If it does not, then the neutralizing capacitors or resistors should be replaced.

Aligning the converter

To align the converter stage, the signal generator and the radio should both be set to 600 kc. Set the output level of the signal generator to one-half that used to align the if stages. Adjust the oscillator coil slug *only* until the agc voltage is at a maximum. Reduce the generator output and readjust the oscillator coil slug for a peak agc voltage reading. Continue this process until there is no longer a variation in agc voltage. Repeat this procedure with the signal generator and radio set to about 1,400 kc. This time the trimmer capacitor on the oscillator section of the tuning capacitor is varied.

After both ends have been adjusted, tune back and forth between them, varying the slug and the trimmer respectively, until there is no longer a wide variation in agc voltage between the two ends. All frequencies that are checked on the dial should produce about the same level of agc voltage for the same generator output setting.

While the converter is being aligned, the settings of the if transformer slugs should not be touched. Doing so will cause the radio to track improperly and will reduce the overall gain.

After alignment has been completed, remove the signal generator and tune in a signal at the high-frequency end. Using the antenna trimmer on the tuning capacitor, adjust for maximum agc voltage. If the low-frequency stations come in weaker, readjust the antenna trimmer, striking a happy medium until all the high-frequency stations come in at about the same level.

The method of alignment of a transistor radio just described is preferable since it allows the agc voltage to be monitored for greater accuracy in tuning the if transformers and rf circuits. Each manufacturer, in his service data sheets, presents his own particular method of alignment of radios manufactured by him. Some prefer the method just described; others prefer to connect the signal generator directly to the stage to be aligned. Whichever method is used, the results should be the same.

General precautions

If you insist on making replacements with the power on, be sure that the base connection is made first. This makes certain that bias is applied when the other elements make contact.

Use the same care in making battery replacements. Be absolutely sure of two things: the voltage is the specified value; the polarity is correct.

Another good rule to follow, particularly for the experimenter, is to avoid high-voltage pulses of transients that could damage the transistor in an instant. When working on new equipment that uses other than very low dc voltages, it is a wise idea to apply the voltage gradually while observing circuit behavior. Also, a capacitive discharge, inductive kick or surge that may result from on-off switching may be large enough to produce a damaging voltage.

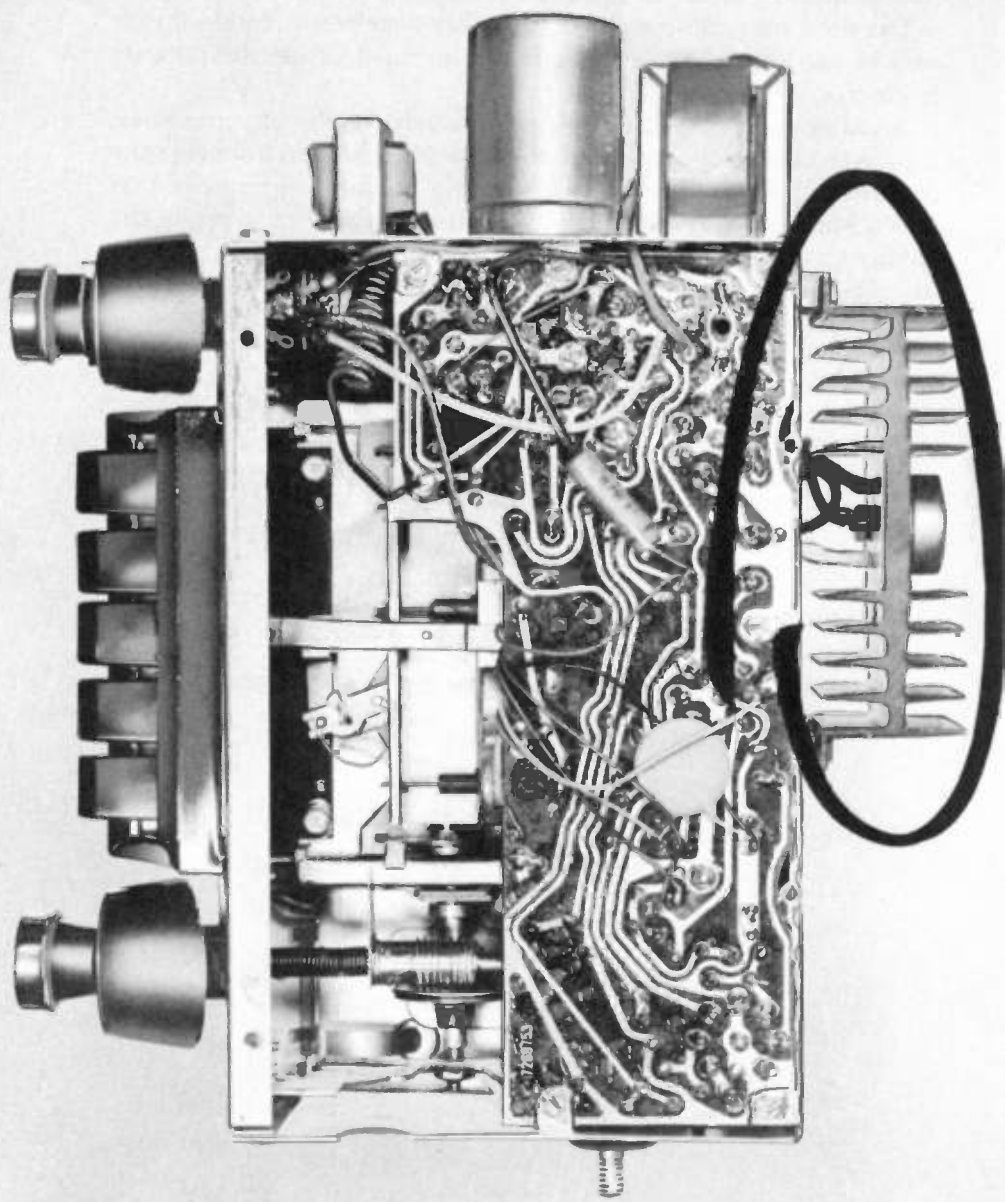

automobile radios

RADIOS designed to operate in automobiles are basically the same as sets used for home entertainment. They are superheterodynes that have an rf amplifier stage (not generally found in the home radio) a mixer stage, a local oscillator, two or more stages of if amplification, a detector, and one or more stages of audio ampli-

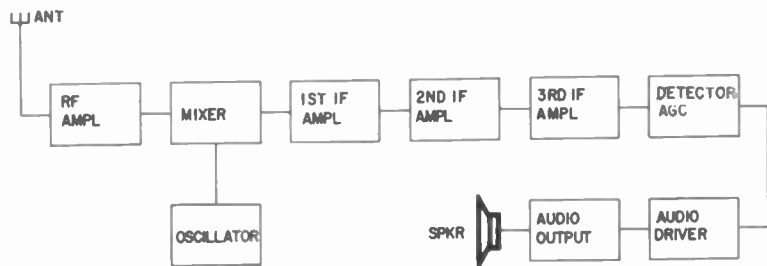

Fig. 501. Block diagram of a typical transistor auto radio.

fication. Fig. 501 is the block diagram of a typical transistor auto radio. Note that this block diagram is identical with that of a vacuum-tube receiver.

The difference between an auto radio and a receiver that is used in the home lies in the provisions made for the operation of the auto radio. Conditions such as working in an intense field of electrostatic and electromagnetic noise caused by the electrical system of the auto, receiving signals with a small antenna, operating from the auto's battery, dictate the design of the auto radio.

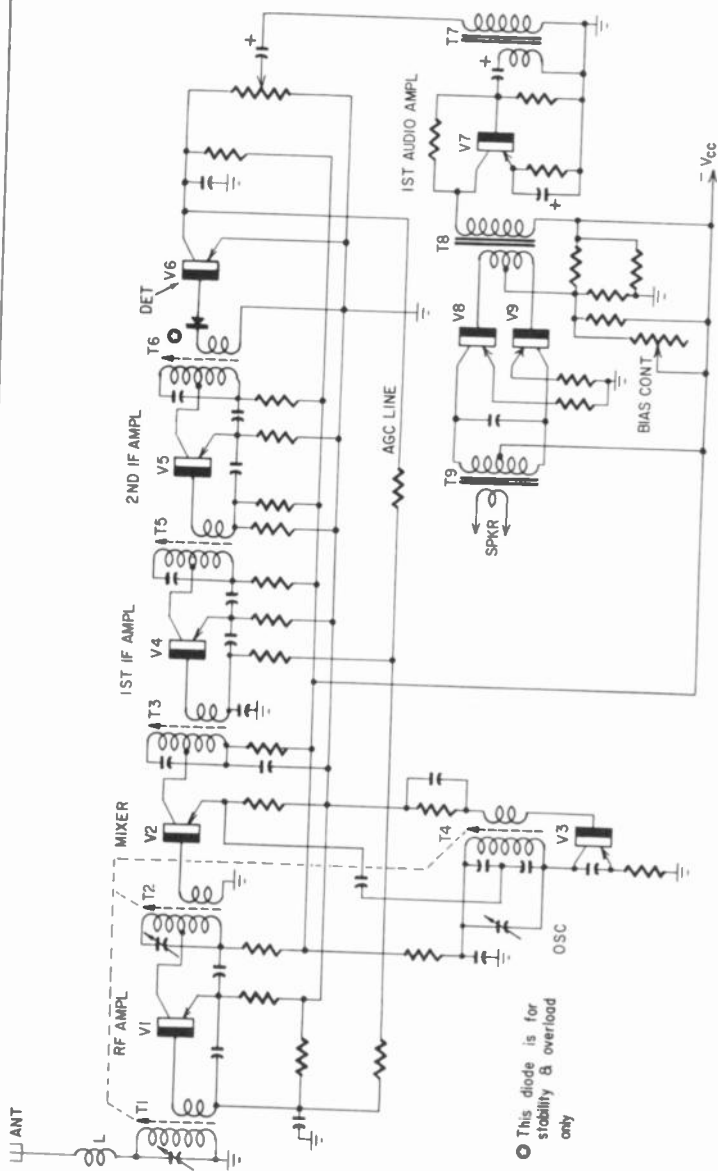

Fig. 502. Schematic diagram of a transistor auto radio. Power is obtained directly from the auto battery.

Transistor auto radios

The schematic of Fig. 502 represents a transistor auto radio circuit. There is little difference between this circuit and the one shown in Fig. 202 (Chapter 2). In the auto radio, because of the small antenna used, a stage of rf amplification is required. The

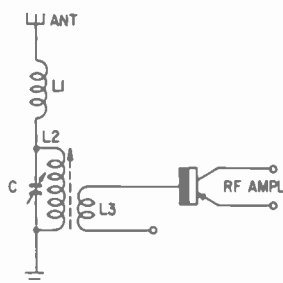

Fig. 503. Antenna input circuit of transistor auto radio.

coupling between the antenna and the base terminal of the rf amplifier transistor is slightly different in the auto radio than it is in the home set. The reason for this difference is that, because of the small antenna used, provision is made to tune the input circuit so that it will match the antenna. This permits a maximum transfer of the signal energy picked up by the auto antenna. The use of a tuned input circuit improves the sensitivity, the selectivity and the signal-to-noise ratio of the receiver.

In the antenna coupling circuit shown in Fig. 503, the signal energy appears across the tuned circuit consisting of L1 and C. This energy is inductively coupled to winding L2 and is applied to the base terminal of the p-n-p rf transistor for amplification. Coil L3 is permeability-tuned and is ganged with the permeability-tuned coils of the mixer and oscillator stages.

Note that the permeability-tuned antenna coupling transformer L2-L3 is a step-down type—that is, there are more turns on the primary winding (L2) than on the secondary (L3). Compare this with the usual antenna transformer found in vacuum tube radios in which the transformer is a step-up type. In the transistor radio the impedance of the antenna circuit is higher than the impedance of the base circuit of the transistor rf amplifier.

Coil L1 shown in Fig. 503 is commonly used in auto radios and you will find it used extensively in communications receivers, especially those that are portable or mobile. Coil L1 is a loading

coil and its purpose is to lengthen the antenna circuit electrically by compensating for the low inductance. Auto antennas are short rods. Using a loading coil has the effect of increasing the apparent length of the antenna.

Capacitor C is used to match the antenna to the input circuit. After the radio is installed in the automobile, the antenna is extended to its full length. The radio is tuned to a weak signal around 1,400 kc. Capacitor C, which is accessible through a hole in the metal chassis of the radio, is then adjusted and is used to peak this weak signal to maximum volume.

There are a number of reasons why capacitor C should be adjusted with the receiver tuned to a weak station. With a weak station the agc voltage will be such that the receiver will be operating with maximum sensitivity. Under such conditions it will not take more than a small adjustment of capacitor C for a change to be noticed. If capacitor C is adjusted when the receiver is tuned to a strong station, agc action will tend to make the output volume fairly uniform and the tuning action of the capacitor will seem fairly broad.

The major advantage of the transistor auto radio is its remarkably low power consumption—2 amperes peak input current, as compared to 10 amperes for a conventional vacuum-tube set. This difference in power consumption is due to the elimination of the familiar vibrator, vibrator power transformer and vacuum-tube filaments. For example, in a typical 6-volt auto radio using vacuum tubes, filament power consumption will be approximately 15 watts. This is eliminated in the transistor auto radio.

Hybrid auto radios

The hybrid automobile radio uses vacuum tubes for the rf and first audio amplifier stages and either one or two power transistors for the audio output stage. Signal driving power for the output transistor(s) is supplied either by a vacuum tube or a low-power audio driver transistor. To obtain optimum impedance matching and maximum power transfer from the audio driver stage to the output transistors, transformer coupling between stages is used.

Operating power for the transistors is obtained directly from the automobile battery (12 volts), while power for the vacuum tubes is supplied by a second pair of power transistors connected in a dc-to-dc converter circuit.

Some of the newer hybrid auto radios use the recently developed low-plate-voltage tubes (Fig. 504). Since these tubes operate with only 12 volts on the plate and screen, and since the power stage

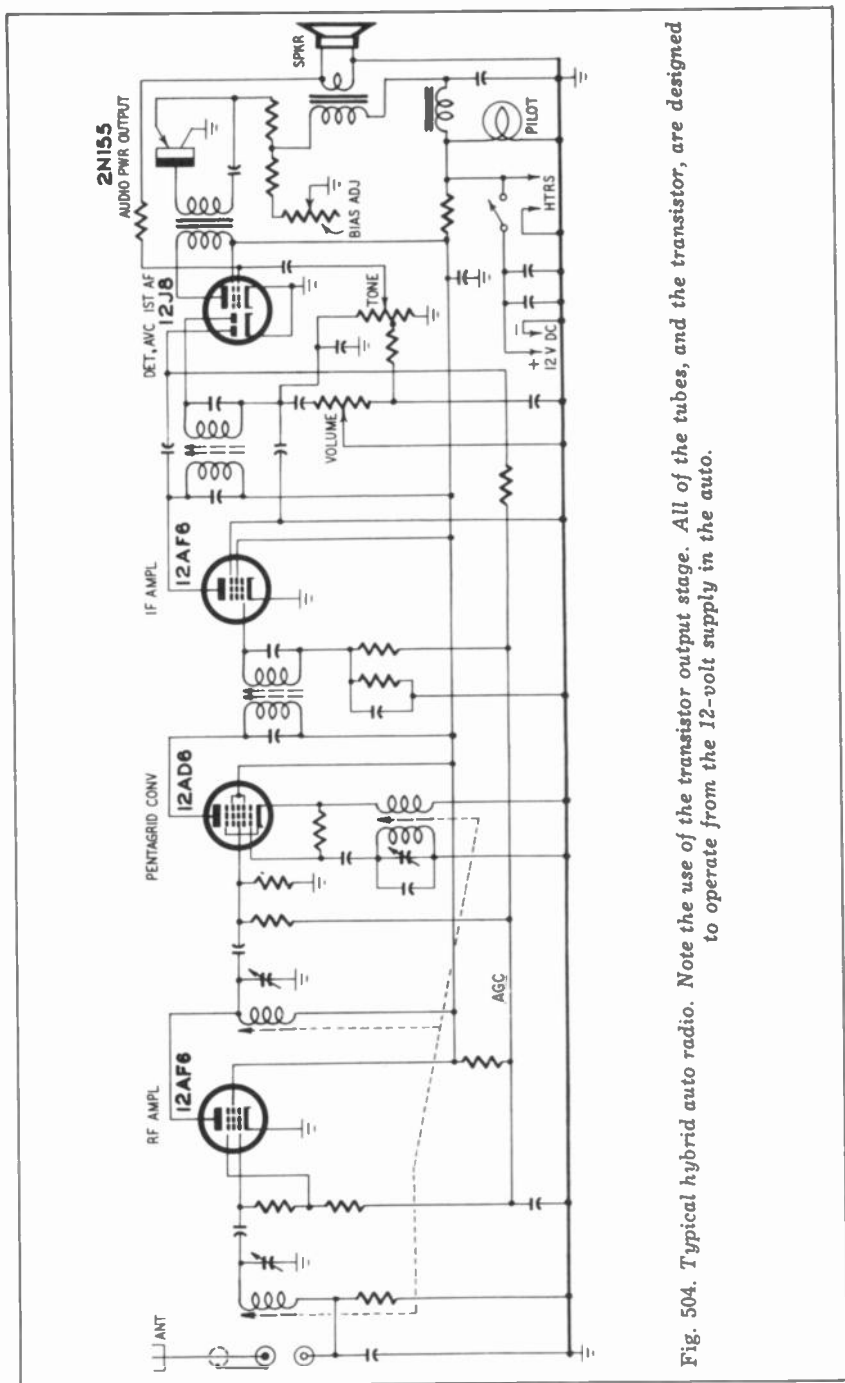

Fig. 504. Typical hybrid auto radio. Note the use of the transistor output stage. All of the tubes, and the transistor, are designed to operate from the 12-volt supply in the auto.

uses one or more transistors, the high-voltage power supply is no longer needed and is completely eliminated. However, although the plate and screen voltages in hybrid auto radios are 12 volts or less, this does not mean that the usual servicing precautions can be ignored. It is true that the chance of shock from high screen and plate voltages does not exist but keep in mind that a storage battery, although only 12 volts, has a tremendous store of energy. The short circuit current of a storage battery can be in the order of 300 amperes or more. A severe burn can be as painful as a shock due to voltage!

Power supplies

Transistor auto radios and modern hybrid auto radios receive their power directly from the automobile storage battery. The earlier type of hybrid radios (those which use conventional

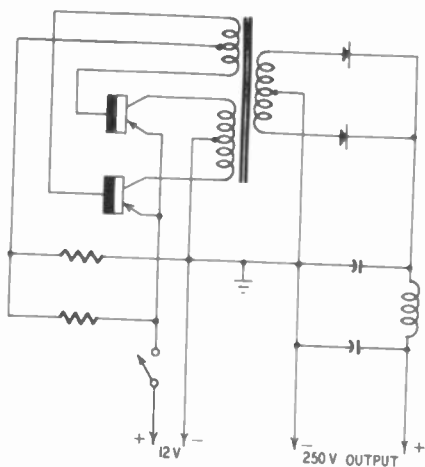

Fig. 505. Transistor power supply.

vacuum tubes) require a higher plate voltage than can be supplied by the battery. This is where the dc-to-dc converter is used.

The converter uses power transistors to replace the vibrator in the power supply. As seen in the schematic (Fig. 505), these transistors are connected to the primary winding of a special power transformer in a push-pull relaxation or blocking type oscillator circuit. When voltage is applied, one transistor conducts sooner or more heavily than the other. The current that flows through the collector of this transistor also flows through one half of the primary winding. This current flow produces a magnetic field which collapses as soon as the conducting transistor reaches cur-

rent saturation. The second transistor, which was cut off, is forced into conduction by the voltage induced in the base winding by the collapse of this field. The second transistor now produces a field 180° out of phase with the first field. As soon as current saturation is reached the field also collapses forcing the first transistor back into conduction, repeating the cycle. Of course, if oscillation

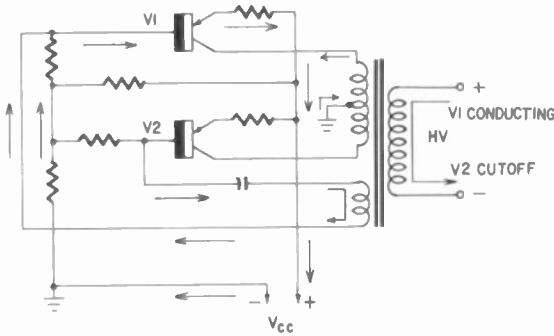
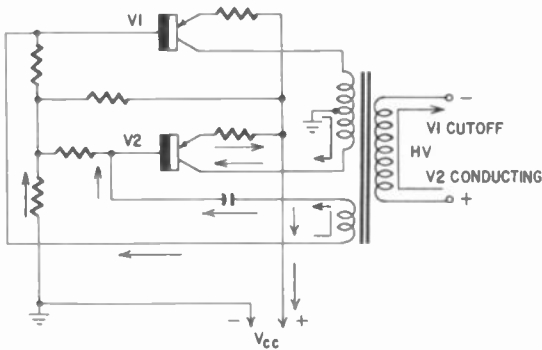

Fig. 506-a. Current flow in the dc-to-dc converter. Note current flow through the upper half of the primary winding.

does not take place in the primary, no voltage will be induced across the secondary winding and the result will be complete in-



ARROWS INDICATE DIRECTION OF ELECTRON CURRENT FLOW

Fig. 506-b. With V1 cut off, current now flows through the lower half of the primary winding.

operation of the receiver. Under these conditions, a dc voltage check across either the input or output filter capacitors will show zero voltage.

The operation of the primary circuit is shown in Figs. 506-a,-b. For those who are familiar with vibrator power supplies the action of the primary will seem quite similar, as it is indeed. The arrows in Fig. 506 indicate the direction of current flow. Note that only one half of the center-tapped primary winding is used at any one time. Since the bases of the transistors are connected 180° out of phase with each other and in phase with the opposite collectors, the transistors switch between saturation and cutoff, much the same as a vacuum tube multivibrator.

The frequency of oscillation is approximately 20,000 cycles and is determined mainly by the inductance of the primary winding. The advantage of operating the supply at this high a frequency is that the problems of filtering, buzz, hum, etc. are virtually eliminated.

The choice of a high oscillating frequency in the primary circuit of the transistor power supply is not accidental. A high frequency means that much smaller values of filter components can be used. Note that if the primary frequency is 20,000 cycles (and if a full-wave rectifier is used) the ripple frequency is 40,000 cycles. At this frequency, filter capacitors of $1 \mu\text{f}$ or less are adequate. This frequency also makes possible the use of a light weight air-core filter choke. The oscillating frequency of the primary and the ripple frequency of the secondary are outside the range of human hearing, hence hum problems do not exist. The elimination of buzz is also interesting. In vibrator-type power supplies, a loose lamination in the power transformer could vibrate at an audio rate, producing an annoying buzz. This is, of course, in addition to the usual buzz produced by the vibrator itself. In the transistor power supply, a loose lamination produces no sound, and since the vibrator is eliminated, there is no buzz.

The high-voltage secondary winding shares the same core and field as the other windings. The voltage that is induced across the secondary is rectified, filtered and applied to the radio. Either a vacuum-tube diode, such as a 12X4, or a semiconductor diode may be used as a rectifier. The filter components are small and bear little resemblance to those used in older sets. The input and output filter capacitors can range anywhere from .05 to $1.0 \mu\text{f}$, while the filter choke is about 100 millihenries and may be air-wound. Aside from the differences in values of the components, the secondary circuit (as shown in Fig. 505) is a typical full-wave rectifier followed by a standard pi-type filter. The arrangement is similar to that used in many vacuum-tube receivers.

The developed ac voltage across the secondary of the power transformer is about 250 (a normal value for auto radios) and can be measured across the winding. If it is not present, then the primary circuit is not oscillating. A defective transistor or rectifier or a B-plus short can cause this. To test for oscillation, the rectifier or load should be removed and an ac vtvm or oscilloscope connected across the winding. If the circuit is operating normally, the meter should indicate 250 volts. If an oscilloscope is used, then the pattern observed should be similar to the one shown in Fig. 506-c. This waveform, somewhat resembling a peaked square wave, is very similar to the waveform obtained with vibrator-type power supplies.

A great advantage of the transistor power supply is that no fuse is required in the input power leads. If a B-plus short occurs, the transistors stop oscillating. As in any oscillator, once the load exceeds a certain value, the amount of feedback available is less than

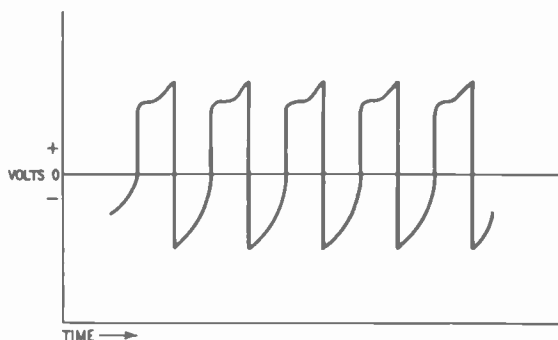

Fig. 506-c. Voltage waveform appearing across the secondary winding of the dc-to-dc converter power transformer.

that required to produce oscillation. Since the base-bias network is such that the transistors are biased close to cutoff, once oscillations cease, the transistors idle at a very low collector current. As soon as the heavy load is removed, the transient that is produced is enough to start the circuit oscillating once more. The amount of current that is required by the oscillating circuit is 1.5 amperes, while the current drawn by the idling transistors is about 100 ma. This low idling current is not enough to affect the transistors even though the heavy load is on for a long time.

Automatic tuning

The search tuner and the transistor automobile radio are al-

most perfect mates and the service technician will find them together in ever-growing quantities. Mechanically, the search tuners used with transistor radios are much like their vacuum-tube brothers; relays and motors are used in both.

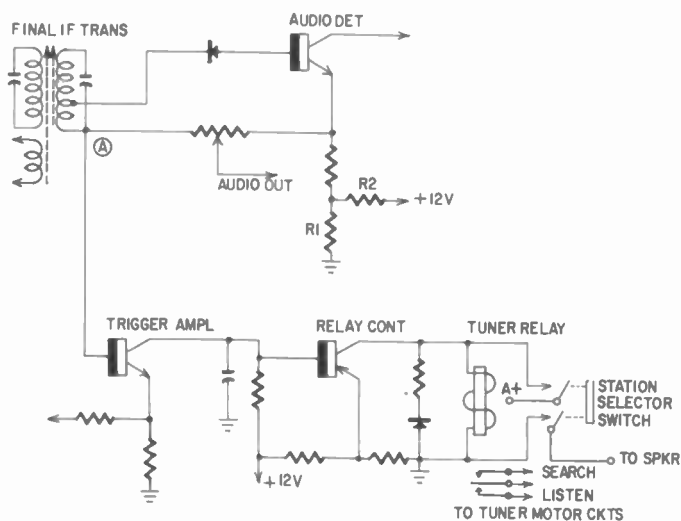

Fig. 507. Typical signal-seeking circuit.

However, electronically the transistor is particularly adaptable to the necessary circuitry and provides a rather simple and fool-proof method of activating the tuner.

Fig. 507 illustrates a typical signal-seeking circuit. The if signal, after rectification, is used as the trigger voltage. It is applied directly to the base of the trigger amplifier, which is biased to a continuous state of conduction. As a station is approached, the negative voltage at point A increases to a value high enough to cut off the amplifier. Since it is no longer conducting, the voltage at the collector is equal to the supply voltage which is applied to the base of the relay control transistor. It, in turn, is cut off, de-energizing the relay, stopping the motor and locking the tuning gear train in position.

The diode in series with the base of the detector prevents de-tuning, or tuning to side bands on strong signals. It is essentially a clipper which prevents the tuner from responding to transient peaks such as encountered when passing sidebands. It also provides for a certain amount of clamping action. The diode across the tuner relay provides for proper polarization and tends to diminish relay chatter.

Age action is, of course, delayed to prevent it from opposing or cancelling the necessary trigger voltage.

Interference and noise

An auto radio operates in an intense field of electrostatic and electromagnetic noise. This noise, generated by the spark plugs, ignition coil, distributor, generator and wheels, is picked up by the wiring in the engine compartment and fed through the firewall

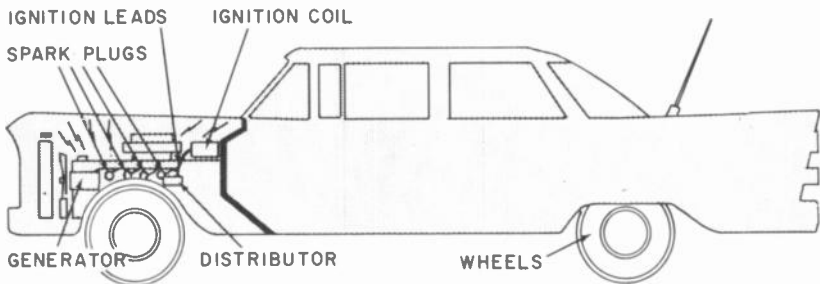

Fig. 508. Points of noise generation in an automobile.

into the radio. The ignition system in an automobile is basically a spark transmitter and as such is a generator of rf energy. The radiations are picked up by the unshielded wiring and any ungrounded metal parts in or around the engine compartment. Fig. 508 shows the points where this noise is generated.

The rf energy generated covers a very large portion of the radio-frequency spectrum and can be detected on any frequency from below the broadcast band to well into the very-high-frequency bands. Its strength is equal to that of a low-power transmitter placed close to the radio. Because of this radiation the radio, as well as all associated leads, must be completely shielded to prevent receiving interference over the entire tuning range. This interference is heard in the speaker as a series of clicks or ticks at the same rate of speed as the firing of the sparkplugs in the engine.

Sparking

Sparking at the brushes of the generator is another source of interference. It is differentiated from ignition interference by its high-pitched whine which varies in pitch as the engine is alternately speeded up and slowed down.

Reducing interference

By placing a suppressor resistor in series with the high-tension ignition lead which connects between the ignition coil and dis-

tributor, three-fourths of the interference generated by the ignition system can be reduced or eliminated. This suppressor resistor dampens oscillations caused by the spark, thereby reducing noise radiation. When installing the suppressor, place it as closely as possible to the distributor (Fig. 509). One suppressor resistor is sufficient to do the job and it will not affect engine performance

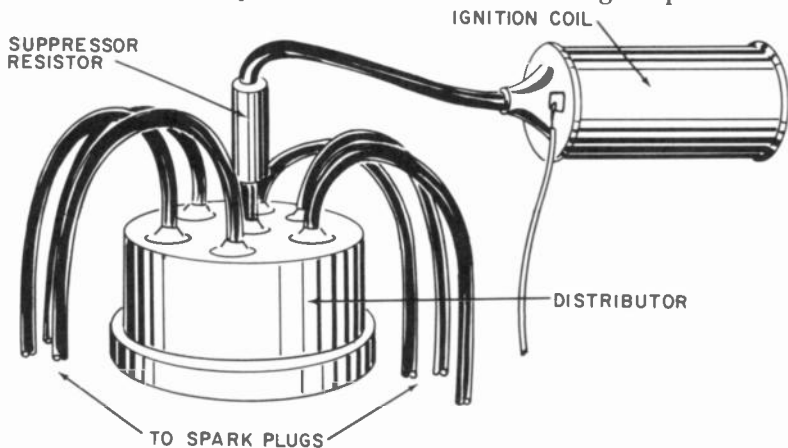

Fig. 509. Installation of noise suppressor between the ignition coil and distributor.

or gas mileage, as was the case in earlier installations when a suppressor resistor was also placed in series with each spark plug. Single type suppressors are generally carbon types.

The nominal resistance of the suppressor is 10,000 ohms. This is a small value when you consider the high ignition voltage—18,000 volts! The effect of the suppressor resistor in damping oscillations can be seen in Fig. 510.

Although the distributor in modern automobiles is supposed to be centrally located, many of the newer cars (especially those with V8 engines) have it located to the rear of the engine, near the firewall or up forward beneath the generator. In these cases the location of the distributor and ignition coil makes it impossible to use a suppressor resistor, since there is not enough room available between the two. The leads between the distributor and spark plugs are very long and become almost perfect radiators for the rf energy generated. When this is the case, noise reduction is almost impossible.

To solve this problem, some automobile manufacturers route these ignition leads through a metal conduit grounded to the en-

gine block. This conduit shields a major portion of the lead and helps to reduce interference.

If the metal conduit is not used in the auto, and other means of

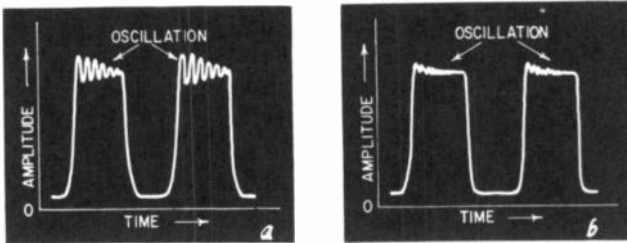

Figs. 510-a, -b. The effect of the oscillation suppressor resistor is shown in these two drawings. The amplitude and the duration of the oscillation waveform are reduced.

noise reduction are impossible, then it is suggested that a metal conduit be installed (Fig. 511) and the ignition leads routed

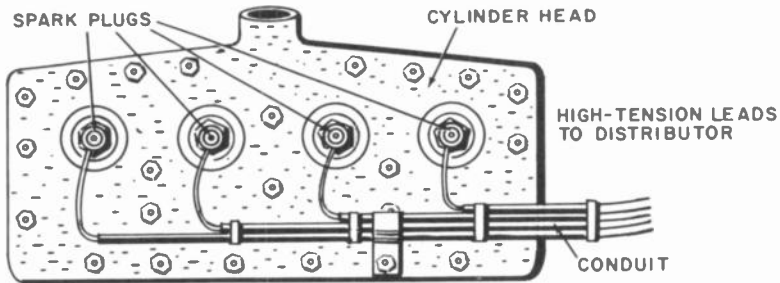

Fig. 511. Installation of metal conduit for the spark plug high-tension leads.

through it. This conduit can be purchased from most any auto parts supply house and is available for most make cars. When ordering, be sure to state the make, model, year and engine type (straight 6 or V8) of the automobile. Complete mounting instructions are supplied with each conduit. In some instances, the point at which you ground the conduit will be critical. If the conduit does not eliminate the noise, remove the ground connection and make sure that the conduit does not touch the metal frame at any point. Connect one end of a wire to the metal frame of the car and with the other end of the wire touch various points of the conduit in succession. The receiver should be turned on

and tuned for maximum noise with someone operating the car while you probe for the best ground point. When you find it, solder metal braid to this spot and ground the other end of the braid.

Another method of minimizing or eliminating ignition interference is to reduce the gap between the electrodes of the spark plug. This causes the spark to be hotter and cause a greater

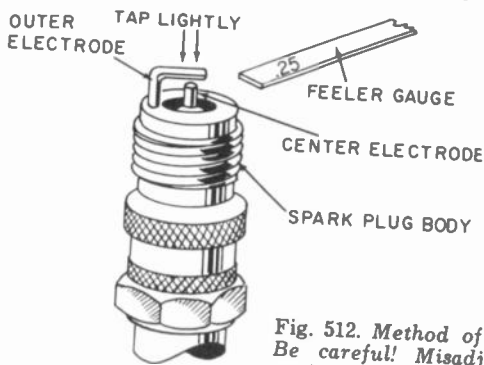

Fig. 512. Method of adjusting the spark plug gap. Be careful! Misadjustment will lead to loss of engine power. Check with your garage mechanic to make sure you aren't improving reception at the sacrifice of engine performance.

current flow between the electrodes. The increase in current flow tends to reduce, or dampen, oscillations of the spark. Depending upon the make of auto and the type of engine, this reduction in gap may be from .009 inch to .09 inch, with .01 inch a nominal value.

To perform this operation, remove each spark plug (one at a time). With a feeler gauge, measure the plug gap (Fig. 512), referring to the manufacturer's specifications for the proper gap. Reduce this gap .01 inch by lightly tapping on the outer electrode with a pair of pliers, checking the gap with the feeler gauge after each tap. When the proper gap width is reached, replace the plug and proceed to the next one. If in tapping the electrode you close the gap too much, it can be spread apart by inserting a knife blade between the electrodes and lifting the outer electrode out and away. Care must be used in tapping and spreading the outer electrode because too much pressure either way may cause it to distort or snap off. This method of noise reduction has proved very successful; in some autos the noise was eliminated completely.

Generator whine

After the clicking sound of the ignition system has been reduced

or eliminated, a high-pitched whine, which changes in tone as the engine speed is varied, may become evident. This noise, caused

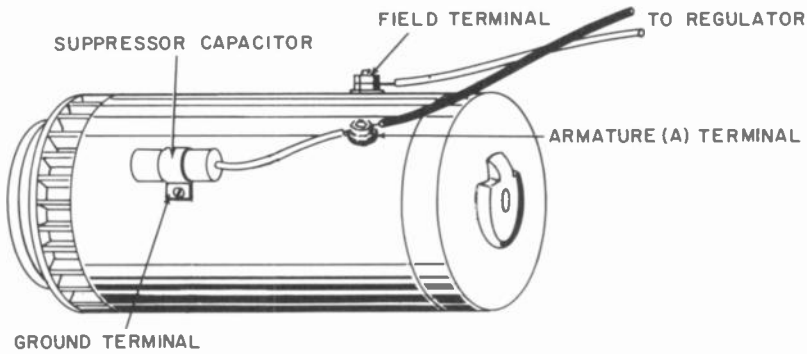

Fig. 513. Installation of suppressor capacitor on the generator.

by sparking at the brushes of the generator, is termed generator whine. It can be reduced or eliminated by placing a capacitor across the armature terminals of the generator. The capacitor is mounted directly on the generator housing (Fig. 513) by a bracket which is an integral part of the capacitor. The insulated lead from the capacitor is then connected to the generator terminal marked A. This is the armature connection. The second terminal on the generator is marked F. This is the field terminal and is not used. When installing this capacitor, remember to scrape the paint from

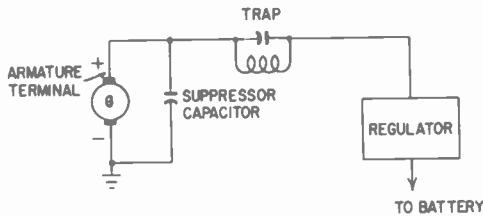

Fig. 514. Connecting the trap between the generator and the regulator.

the generator housing around the area where the capacitor is to be mounted. This is to insure a good ground connection for the capacitor.

Sometimes this capacitor is incapable of reducing or eliminating generator whine. When this happens, a tuned L-C trap inserted in series with the lead connecting the armature of the generator to the regulator block may be necessary. This trap is nothing more

than an L-C circuit tuned to the broadcast frequency. It allows all frequencies produced above and below the broadcast band to pass through, but blocks any noise generated in the broadcast band.

The coil for the trap consists of 100 turns of wire wound in layers on a 1-inch-diameter form. The wire size (use about a number 8 or number 9, A.W.G.) should be large enough to carry the current generated (about 25 amperes, at 12 volts). This wire is rather large in diameter so the coil will be fairly bulky. The value of capacitance can be found by using a capacitor decade box or a variable 365- μmf capacitor. Fig. 514 shows how the trap is connected in the generator circuit.

When the trap is mounted, it can be adjusted by the following method: First, start the engine and let it idle. Tune the radio to a point between stations, at any place on the dial. Increase the speed of the engine until the generator whine is heard. With the engine running at a fixed speed, increase the volume of the radio and vary the capacitor on the trap until the generator whine is reduced in volume or completely eliminated. Fix the setting of the variable capacitor or substitute a fixed value for it. Once this trap is adjusted, it is not necessary to retune it.

If either of these methods of reducing generator whine proves ineffective, then the only other thing that can be done is to replace the brushes or reface the commutator segments of the armature.

Static

Still another source of noise is the periodic popping sound caused by a charge of static electricity generated by the rotation of the wheels or brake drums and discharging to the axle. This type of noise occurs only on dry cool days and is not regarded as serious. Wheel static interference is characterized by a periodic popping sound in the speaker and can be eliminated by installing static-collector springs. These springs are mounted beneath the axle lock-nut dust cap, and ground the wheel to the axle (Fig. 515). Inserting graphite powder into the inner-tube of the tire also helps to eliminate wheel static. A complete kit for reducing this type of interference, which includes the graphite powder, a tire injector and static-collector springs for all makes of autos can be purchased at any local radio or auto parts supply house. The graphite can be blown in with an air hose when the tire is inflated.

As an added point, hanging a strip of rubber from beneath the auto to make contact with the ground while riding *does not* dis-

charge any wheel static that may be generated. In some instances just the opposite may occur. A static charge may be built up to cause annoying interference. (Generally, rubber is non-conductive although some conductive forms have been manufactured.)

Installing the auto radio

Fig. 516 shows a typical auto radio installation. The radio it-

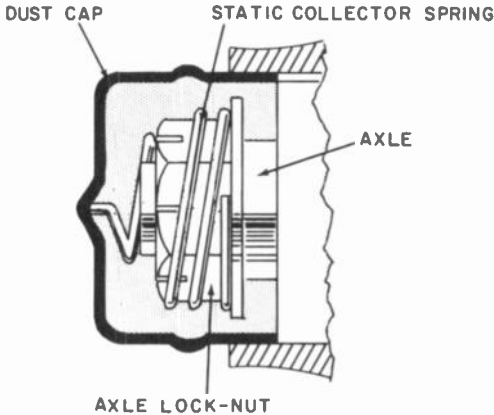

Fig. 515. Installation of static-collector spring on the axle.

self is mounted to the instrument panel or to the firewall by a bolt or brackets. The controls of the radio protrude through a

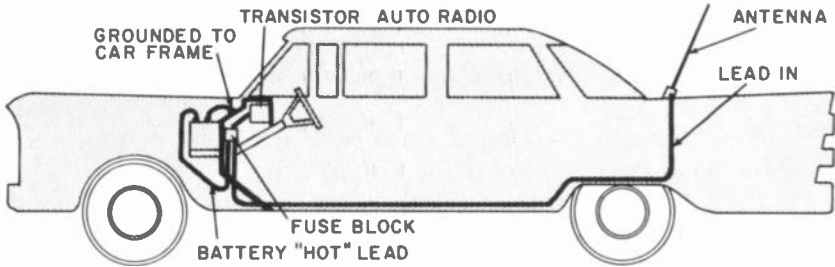

Fig. 516. Typical transistor auto radio installation.

cutout in the instrument panel and are easily accessible. The speaker may be mounted separately, or it may be a part of the radio chassis itself. The antenna is mounted as far away as possible from the engine compartment to reduce pickup of engine interference. The lead-in from the antenna to the radio is shielded

and is routed through the interior of the auto. This also helps to eliminate interference.

Power for the radio is obtained through a lead connected to the ammeter (if there is one) or from a lead connected directly to the power-distribution fuse panel mounted on the firewall beneath the instrument panel. This lead is "hot" and is usually connected to the positive terminal of the storage battery. The radio chassis and the body and frame of the auto act as the common return lead. When installing a transistor radio, or any radio that uses a transistor, correct battery polarity must be observed. In some autos the positive terminal of the battery is grounded to the frame.

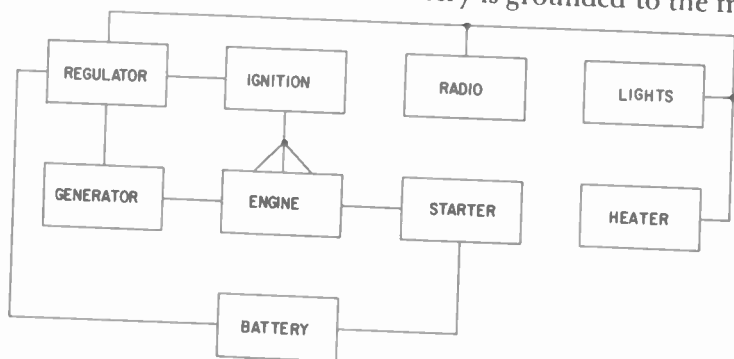

Fig. 517. Block diagram of the electrical system of an automobile.

Since the transistor radio usually has the negative lead connected to its chassis, mounting the radio in an auto with a positive ground will cause irreparable damage to the transistors. Always check whether ground (the car frame) is positive or negative (that is, whether it is connected to plus or minus of the storage battery) before installing the transistor radio.

A block diagram showing the power distribution of the auto's electrical system is illustrated in Fig. 517.

If, after installation, interference overrides the received signal, then the methods of reducing or eliminating interference previously described should be used. This interference need not be eliminated entirely. Like the hum in a vacuum-tube home radio, a certain amount of interference can be tolerated. Of course the owner of the auto should have the final say as to the permissible amount, but the service technician should have an idea of the normal degree of allowable interference.

Reception of local or strong signals should be completely free of any interference, while distant or weak signals may have some

noise riding in the background. Interference is to be expected between stations because the agc voltage is at a minimum, bringing the gain of the radio up to a point of maximum sensitivity. Some audio radios may have a noise-limiter or audio-squelch circuit that cuts out the noise between stations.

All in all, once the radio is installed and interference is reduced, very little servicing of the interference suppressors is needed. If the interference returns after service repairs have been made on the auto or engine it may be only because the suppressors may have been removed by the auto mechanic in the course of his work and not replaced. An occasional check of all mounting nuts and brackets for rusting or corrosion helps keep noise down. The high-tension leads from the ignition coil to the spark plugs should also be checked and kept free from oil, grease and dirt. This not only reduces or eliminates noise but also improves the performance of the engine by making more positive connections in the auto's electrical system.

Service notes

Servicing of transistor auto radios follows the same general procedure as servicing the transistor home radios. The servicing of the hybrid auto radios also follows the same procedure as that for servicing conventional vacuum-tube sets. There are some differences though, and it is important to recognize and know them.

Auto radios are polarized. If polarity is reversed, the radio may be irreparably damaged.

Never turn the radio on without a speaker connected to the output transformer. Failure to do so may permanently damage the power transistors and output transformer.

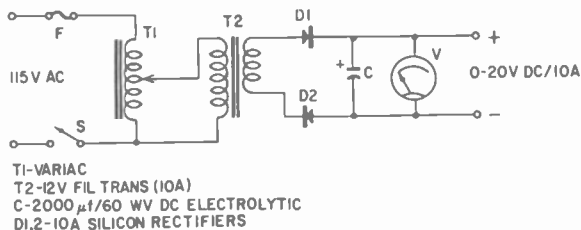

Fig. 518. Schematic diagram of an ac bench supply for testing transistor auto radios. The output is variable from zero to 20 volts dc.

Most bench type ac supplies are poorly regulated. So, when the radio is first connected to it, high current surges are developed

and these can damage the transistors. Always use a battery for a supply. If a battery is not available and an ac supply must be used, always start at the lowest voltage output and slowly increase the voltage to 12, after the radio is turned on. The ac supply shown in Fig. 518 is ideal for this purpose, since a Variac is used to control the input voltage. This supply is adequately filtered and will deliver up to 10 amperes of current at 12 volts.

Because of the heat developed in a power transistor during normal operation, some means must be provided to dissipate it. This is accomplished by a heat sink. Sometimes though, the heat produced by the transistor or by the engine or heater in the auto may be too great to be dissipated efficiently by the heat sink. When this occurs, the collector current increases rapidly and thermal runaway occurs. To keep this from happening, a thermistor is employed in the circuit. The thermistor, a temperature-sensing resistor whose resistance depends upon temperature, is connected across the base-bias resistors and next to the transistor. As temperature increases, the resistance of the thermistor decreases. This lowers the forward bias between the base and emitter, bringing the collector current close to cutoff and thereby preventing any serious damage from occurring to the transistor.

If it is ever necessary to replace the power transistor or any of its associated components, the transistor bias control (Fig. 502) should be adjusted for maximum resistance. After replacement of the defective transistor or component, the radio should be turned on and the control adjusted until there is no distortion of the signal as heard in the speaker. A 500-milliamperere meter can be connected in series with the collector lead and the current adjusted to 450 ma for a class-A or 50 ma for a class-B power stage. The manufacturer's service data sheet should be consulted for the correct value of idling current.

Because of the low input and output impedances that are typical of the power transistor, special transformers are used. In some cases a tapped autotransformer is used to couple the relatively high output impedance of the transistor audio driver stage to the low input impedance of the power transistor. Also, a single-ended output stage may use an autotransformer for coupling the transistor output to the speaker voice coil, tapping down on the winding for proper matching. Then, too, the output transformer may be eliminated completely by connecting the speaker voice coil directly to the transistor collector.

Servicing techniques

Transistor receivers present new types of troubles and require new servicing methods. As in tube sets, when the receiver is defective the first step is to find the defective stage. But, here is where the process changes. In the transistor receiver two types of checks must be made. First is the usual process of signal injection (de-

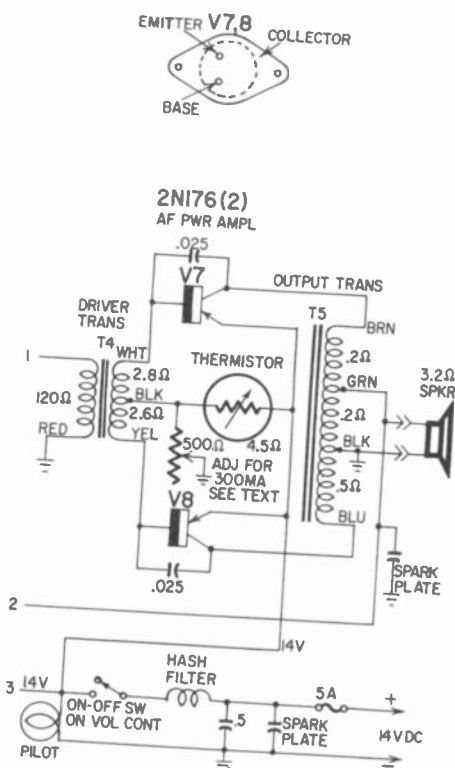

Fig. 519-b. Af power amplifier stage of the receiver shown in Fig. 519-a.

scribed in detail in Chapter 4) to locate faults in signal circuits. (Be sure that the generator's output is set so low that it can't possibly damage the transistors.) Now for the next step. *Measure the voltage drop across the emitter resistors* whenever such resistors are used. This pinpoints troubles in the bias circuits. As a sign of how important this is, take a close look at Figs. 519-a,b. Here, as in the service manual, voltages that should be present across the emitter resistances are on the schematic.

These voltage drops indicate the amount of current flowing through the stage when it is properly biased. Any defective component in the bias circuit, including the transistor, will change the bias voltages, changing the current and therefore changing the emitter resistor voltage drop. Any voltage drop that varies very much from those shown in the schematic indicates a defective stage.

Before going any further, check the battery voltage with the receiver turned on. If the voltage is normal (or near normal) your next step is to determine whether the transistor or the bias network is at fault. This is done by substituting a known good transistor in the stage. If the emitter resistance voltage drop remains the same, the original transistor is good; if it returns to normal, the transistor was bad. If this test shows the fault to be in the bias network, resistance checks will locate the defective part.

Weak reception is often caused by open bypass capacitors. To speed the checking of these units, use a capacitor subber (see Fig. 520). To use this aid, attach the alligator clip to the chassis

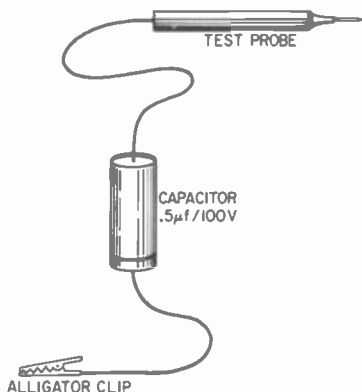

Fig. 520. Simple test unit for checking bypass capacitors.

and touch the probe to the ungrounded end of the bypass capacitors. If a bypass is open, volume will increase when it is shunted. When checking the audio section there may be no increase in gain, but the pitch of the sound will change when an open bypass is shunted.

A few additional precautions

Do not short any part of the circuit to ground while testing, even though this may be a common practice in tube-set servicing. For example, if a transistor base is grounded, bias is removed and excessive current can flow through the transistor, causing permanent damage.

When replacing power transistors, use a replacement with the same color type stamping. If the one you take out has the type number in white, replace it with another white one.

When installing the replacement, be sure the insulator is in place and that mounting screws are tight. If the insulator is left off, the transistor is shorted. If mounting screws are not tightened, there is not enough heat dissipation.

Whenever a power transistor is changed, collector current must be adjusted. See the service manual for the proper method to use on the set you are repairing.

Quick check techniques

With the exception of the dc-to-dc converter and the inclusion of an rf amplifier stage, auto and home receivers are fairly similar. The servicing techniques described in Chapter 4 are also applicable to auto radios. The dc-to-dc converter, however, does present a few additional servicing problems.

Dc-to-dc converter

Quick check: Disconnect load or remove rectifier. Connect a meter across the high-voltage winding. Full voltage should be indicated.

Symptom	Cause
Low B-plus output	Leaky filter capacitor
	Change in value of emitter resistors
	Change in value of base-bias resistors
	Defective rectifier
	High-resistance short in set
	Shorted turns in high-voltage winding
	Defective transistor

No output voltage

Shorted B-plus line
Shorted filter capacitor
Open filter choke
Shorted suppressor capacitor
Open emitter or base-bias resistor
Defective rectifier
Open or shorted high-voltage winding
Defective transistor(s)

Squeal in set

Open second filter capacitor

NOTE: The items listed under "Cause" are in the order of relative frequency of occurrence.

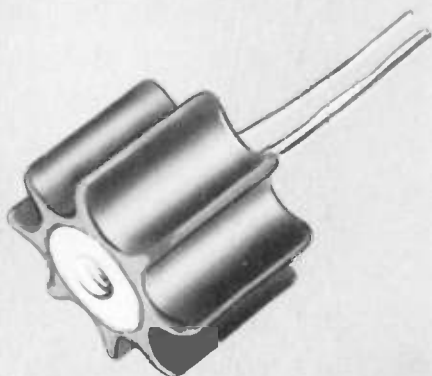
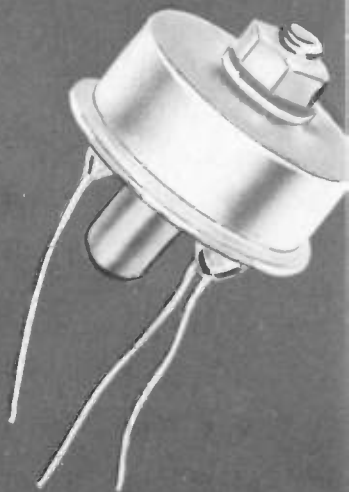
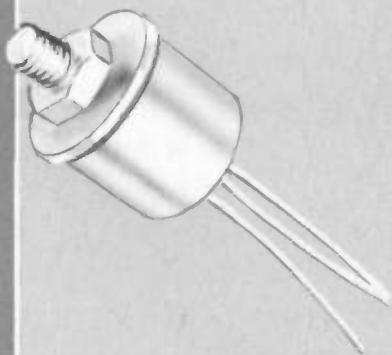
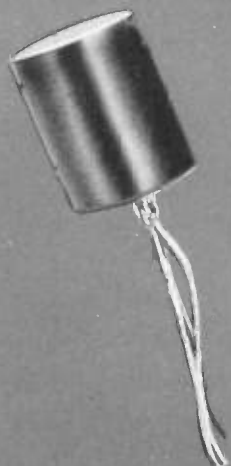

transistor circuits

BESIDES the superheterodyne transistor portable radio, other equipment on the market available for home entertainment use includes hi-fi tuners, regenerative receivers, preselectors, trf's, converters and all-wave radios.

Regenerative receivers

These radios usually consist of two or three transistors with either earphone or earphone and speaker operation. The combination depends upon the manufacturer.

Fig. 601 is the schematic of a simple two-transistor regenerative receiver. One transistor is used as the detector and the other as an audio amplifier. The detector transistor is a high-gain unit with a cutoff frequency of about 5 mc. The audio transistor, also a high-gain unit, is capable of delivering about 2 milliwatts. Since this transistor operates in the audio range, the cutoff frequency is not too important.

The regenerative detector circuit is similar to that used with vacuum tubes. A tickler feedback coil is used to couple the output circuit inductively to the tuned input circuit. This arrangement is much the same as the oscillator circuits described in Chapter 2. Since regeneration is positive feedback, the gain of the stage is very high. Because of this no rf amplification of weak signals is necessary: the sensitivity of the detector is increased by the rf amplifying characteristics of regeneration.

As with a vacuum-tube regenerative detector, the regeneration control is adjusted to a point just short of oscillation. It is at this

point that the detector is most sensitive—with a 2-foot antenna stations as far as 450 miles distant have been received.

The regeneration control is connected in the base circuit of the detector transistor and governs the amount of base bias which, in turn, establishes the gain of the transistor. Adjusting the gain of the transistor controls regeneration. When the circuit is operating properly, a hiss will be heard in the earphones. If the regeneration control is advanced beyond the point of maximum sensitivity, an annoying shrill squeal or howl will be heard. The regeneration control is used to eliminate heterodyning (squeals) on stations when tuning is normal.

Regenerative receivers, whether vacuum tube or transistor types, can operate like miniature broadcast transmitters if not handled properly. Regeneration increases the gain of the stage to which it is applied. If, however, the amount of regeneration is raised to the point where all input circuit losses are overcome, the

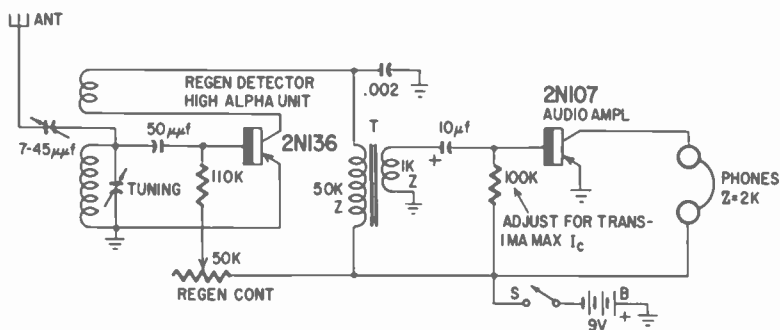

Fig. 601. Simple two-transistor regenerative receiver. The regeneration control must be carefully adjusted to the point at which regeneration takes place. Excessive feedback will cause oscillation.

stage will go into oscillation. At this point the regenerative stage becomes a generator in its own right and will pump energy into the antenna to which it is connected. In any regenerative receiver it is always best to use a minimum amount of positive feedback. Do this by adjusting the regeneration control and listening carefully. There will be a very definite point at which regeneration will take place. For maximum stability advance the regeneration control just slightly beyond this point.

The simple regenerative receiver in Fig. 601, although practically foolproof, can still require servicing. A common trouble is failure to regenerate. Feedback will not take place if the leads

to the tuning coil or to the feedback coil have been accidentally transposed. If all checks indicate that nothing is wrong, try transposing *either* the leads to the tuning coil or the feedback coil.

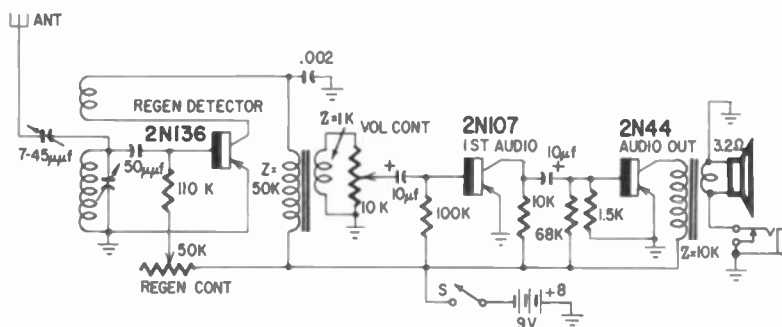

Fig. 602. Three-transistor regenerative receiver. The values of tuning inductance and capacitance will determine the frequency range the receiver will cover. The antenna trimmer capacitor is quite critical.

The audio section can be tested quite easily by the same audio stage checking methods described earlier. If an injected audio

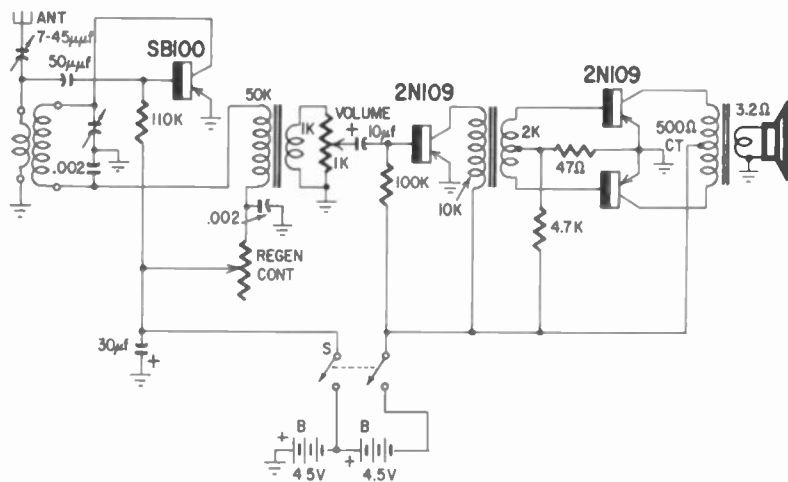

Fig. 603. Schematic diagram of a shortwave regenerative receiver. A tapped battery supply is used. Plug-in coils cover the shortwave bands.

signal comes through clearly and with sufficient volume, the trouble is obviously in the first stage of the receiver. A quick and easy way to check the audio circuit is to connect a crystal diode to

the "hot" end of the primary of transformer T (in Fig. 601) and the other end of the diode to an outside antenna. You will probably hear signals of a number of stations simultaneously but at least this will indicate that the audio amplifier is working. In making this test, crystal polarity can be disregarded.

Fig. 602 shows the circuit diagram of a more elaborate regenerative receiver. Two stages of audio amplification are used, and either earphone or speaker operation is provided. Operation of

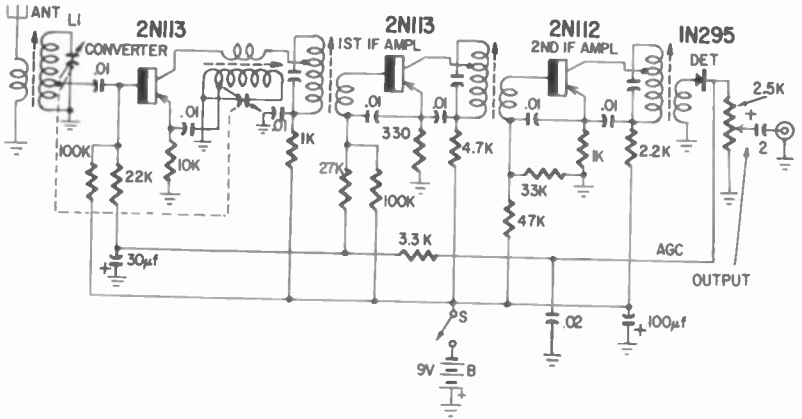

Fig. 604. Schematic diagram of a transistor hi-fi tuner. The output of the tuner can be fed into a suitable audio amplifier. A tuner of this type requires very careful design.

this radio and servicing techniques are the same as for the one just described.

Fig. 603 shows the circuit diagram of a shortwave receiver using a regenerative detector. This circuit makes use of a surface-barrier transistor (SB100) in the detector stage to cover the entire range of frequencies from 1.6 mc to 35 mc (bandswitching is used). Two audio transistors are also used to drive a speaker. The operation of this receiver is the same as for the first one described.

Under normal operating conditions, these radios rarely if ever require servicing. A common trouble is low sensitivity due, not to defective components, but to a weak battery. Replacing the battery clears the trouble. If, after replacing the battery, the sensitivity is still low, then the antenna trimmer capacitor is not adjusted properly. This capacitor should be rotated to give maximum volume without uncontrollable squeals or distortion on any signal tuned in. Best results are obtained by setting it to a signal tuned in at the high-frequency end of the band.

The regeneration control used in these radios is wirewound, although some may use a carbon-film type. After a period of time, these carbon controls become noisy and "touchy." When this happens, the control can be cleaned. To prevent this trouble from recurring, it is best to replace a carbon-film control with a wirewound unit.

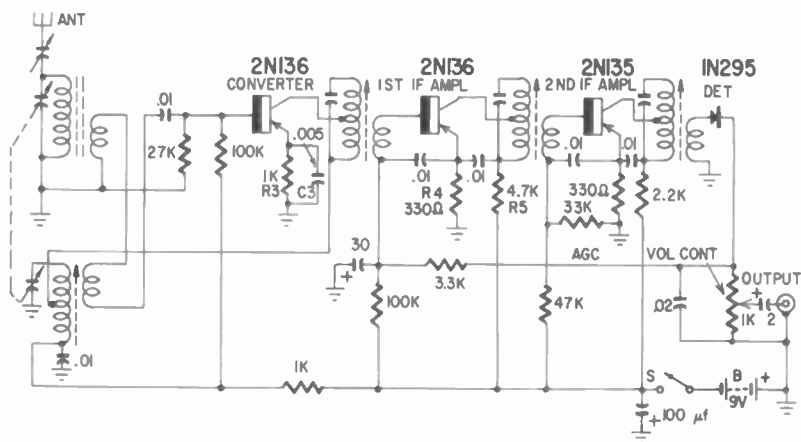

Fig. 605. Another arrangement of a hi-fi tuner. The if coils are tapped down for better impedance matching. The output of a tuner of this type should be fed into a high-quality audio amplifier.

The Colpitts oscillator circuit in Fig. 603 makes use of interchangeable coils to cover the various shortwave bands. No matter what technique is used for switching coils, the problem of poor or dirty contacts is always present. If changing coils or switching them results in noise, instability, plopping sounds, or if the receiver falls out of regeneration, examine the connections. If necessary, clean with any standard commercial lubricant cleaner. Mechanical problems also extend to slug-tuned coils. Slugs can break away from their screws. Sometimes a polyiron slug turned too far into a coil will short the soldering terminals at the end of the coil. Loose slugs can be held in place with a drop of radio cement.

Hi-fi tuners

A hi-fi tuner is nothing more than a superheterodyne radio minus the audio stages. The circuits shown in Figs. 604 and 605 are typical. Here three transistors and one diode are used to help perform the functions of the converter, if amplifier and detector stages.

Since the tuner operates into a high-fidelity amplifier, it is designed to insure distortion-free performance. The proper choice

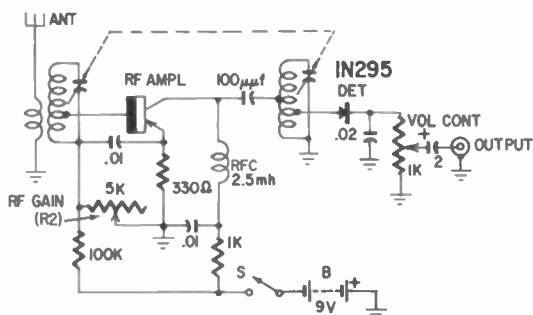

Fig. 606. Hi-fi tuner of the tuned-radio-frequency type. This unit does not have the selectivity of superheterodyne tuners. The unbypassed emitter resistor provides negative feedback. The collector is impedance coupled to the output circuit.

of components and transistors, for optimum matching, is of prime importance. For this reason the price of a tuner with three transis-

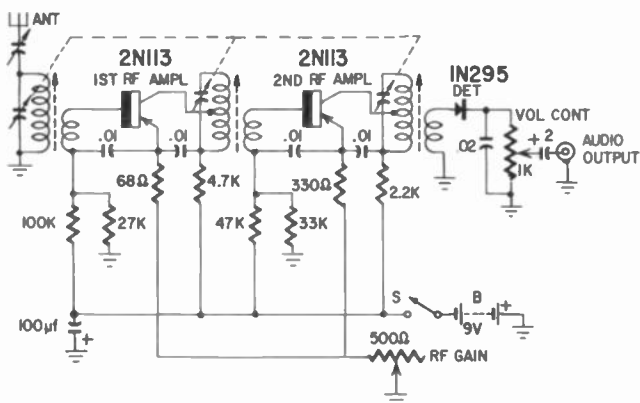

Fig. 607. This hi-fi tuned-radio-frequency tuner is somewhat more complex but has greater selectivity than the unit shown in Fig. 606. A three-gang tuning capacitor is required. Transformer coupling is used throughout.

tors may be far higher than that of a seven-transistor portable radio.

Some high-fidelity tuners available are not of the superhetero-

dyne type. These trf units consist of one or two stages of rf amplification and a detector. They are preferable to superheterodyne

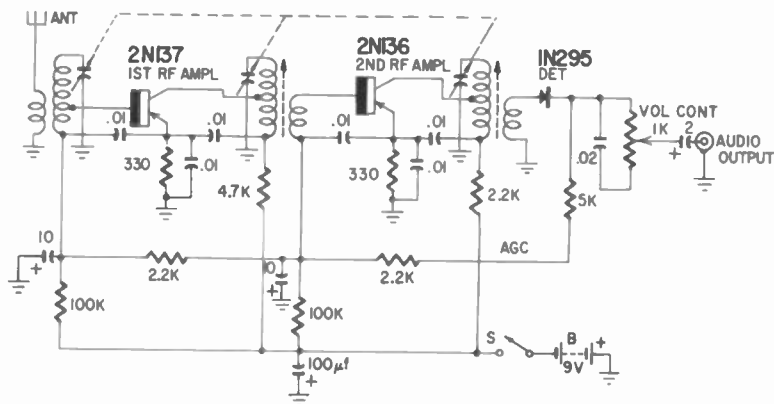

Fig. 608. This hi-fi tuned-radio-frequency amplifier is a variation of the one shown in Fig. 607. In this unit the diode detector supplies agc voltage for the first and second rf amplifier stages.

tuners because of their distortion-free output, although they do not have their sensitivity nor the selectivity. If sensitivity and selectivity are required, then many stages of rf amplification must

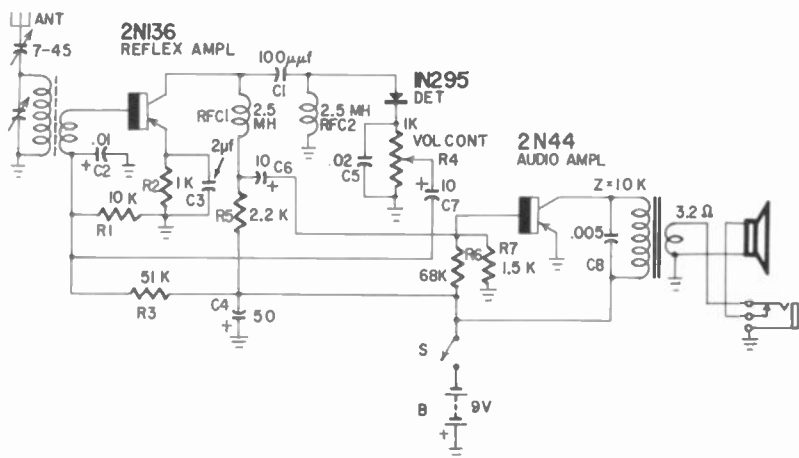

Fig. 609. Reflex-type tuned-radio-frequency transistor portable receiver. After detection the audio signal is fed back to the rf stage for further amplification. Both rf and audio then appear in the collector output of the reflex amplifier. An L-C arrangement is used to separate the two signals.

be used. A circuit of this type becomes a monstrosity, both in design and operation, and the cost will be very high.

The circuit diagrams of three trf type tuners are shown in Figs. 606, 607 and 608. The tuner of Fig. 608 incorporates agc to prevent overload.

Trf's

A simple transistor radio that is relatively inexpensive, the trf is very popular—especially among the small fry. At present only one type of trf radio is available. It consists of a reflex rf amplifier stage, a detector and an audio amplifier stage. Two transistors and one diode make up its complement. The circuit diagram is shown in Fig. 609.

A ferrite-core antenna is used, and the sensitivity of the radio is enough to receive stations up to 10 miles distant without the use of an external antenna. Provision is made for connecting one. The rf amplifier doubles as an af driver supplying enough audio voltage to drive the output transistor.

The rf signal, after amplification, is applied to the diode detector. The resulting audio signal tapped off the volume control is then fed back to the rf amplifier stage through C7. This audio signal, after further amplification by the reflex amplifier is then applied to the base of the output transistor for additional amplification. The audio signal is brought up to a high enough level to drive a 4-inch PM type speaker.

An analysis of reflex operation was supplied beginning on page 58. Although the reflex circuit described earlier was a super-heterodyne and the one shown in Fig. 609 is a trf, the way in which the reflex works is the same for both types.

It is important to be able to trace the path of the audio signal since any defect or break in this path results in weak or distorted audio or complete absence of audio output. After rectification, the audio signal passes through coupling capacitor C7 to the base of the reflex amplifier. The audio signal path can then be traced from the collector of the reflex amplifier to the junction of C1 and RFC1.

A knowledge of the audio path is necessary for intelligent servicing. In the absence of audio output, for example, check for the presence of audio across the volume control. If you get audio here, check components in the audio path for trouble. The difficulty will generally be caused by a defective coupling capacitor (C6) or an open choke (RFC1).

The volume control is placed in the detector circuit and acts as the diode load resistor. Choke RFC2 is the ac load for the detector and completes the dc circuitry. Capacitor C5 bypasses any rf present at the detector output. Provision is made for connecting an

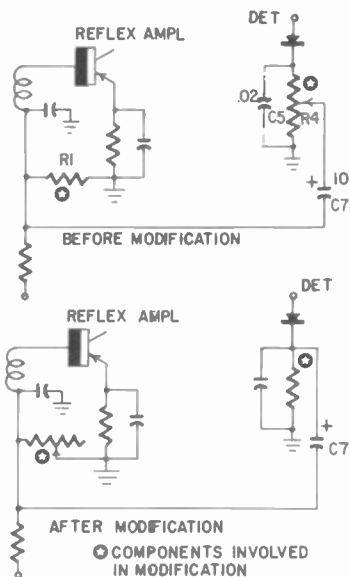

Fig. 610. Modification of the receiver illustrated in Fig. 609 to prevent signal overload and distortion. The text describes the modification details.

earphone. Inserting the earphone plug automatically disconnects the speaker. Although a low-impedance earphone is recommended for best results, just about any impedance earphone can be used.

Station overlap and cross-modulation of a weak signal by an adjacent stronger one do not indicate a defective radio. This is a feature that is typical of trf's in general, and cannot be eliminated. But distortion of the audio on all received signals, squeals, whistles, reception of strong signals only at the low end of the band, means that the battery should be replaced. If, after replacing the battery, the audio is still distorted with speaker operation but is clear when a high-impedance earphone is used, then the audio output transistor should be replaced.

One of the strongest and most frequent customer complaints about this type of radio is distortion of the audio on strong signals. This is because of signal overload, since agc is not used. The only

way to provide satisfaction is to insert an rf gain control. This modification can be done by:

- 1). Removing the volume control (R4 in Fig. 609) from the circuit;
- 2). Replacing the volume control with a fixed resistor of the same value;
- 3). Connecting the audio coupling capacitor (C7 in Fig. 609) directly to the diode;
- 4). Removing the base bias resistor (R1 in Fig. 609) from the circuit, and
- 5). Replacing this resistor with a control of the same value.

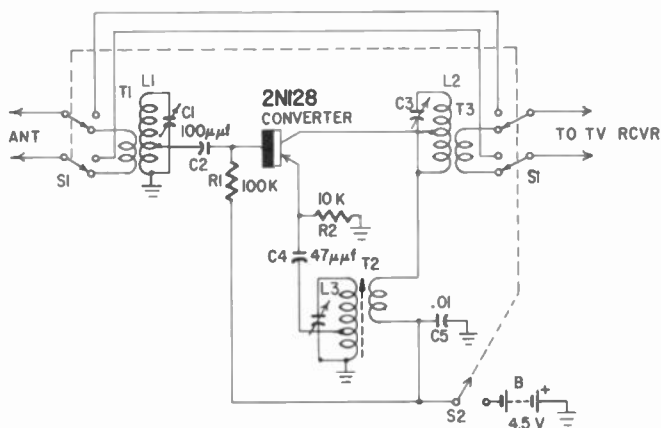

Fig. 611. FM converter using a single transistor. This converter enables the TV receiver to be used for the reception of FM signals. The switching arrangement is designed so that the converter can be switched out of the way when television reception is desired.

Fig. 610 shows the complete modification, before and after. This arrangement controls the gain of the reflex amplifier stage, which means that both the rf and audio gain are varied simultaneously.

A single 9-volt battery supplies power at a current drain of approximately 3 ma. Maximum audio output is 12 mw.

Converters

Converters are used to enable a radio to receive signals on frequencies other than those for which it was designed. Although the majority of converters manufactured are intended for amateur radio, a few have been designed for home-entertainment.

The converter shown in Fig. 611 is employed in conjunction

with a television receiver to enable it to receive FM signals (88 to 107.9 mc). The output frequency of the converter is tuned to an unused television channel below the FM band, usually channel 3, to prevent feedthrough of the unwanted television signal.

A single transistor of the surface-barrier type plus a tuned circuit, L1-C1 is used to cover the required frequencies. No rf amplification is required since the strength of the FM signal and the sensitivity of the television receiver are high enough to receive all the local FM stations. The entire converter is self-contained and operates from three penlight cells (4.5 volts). Total current drain is about 1 ma.

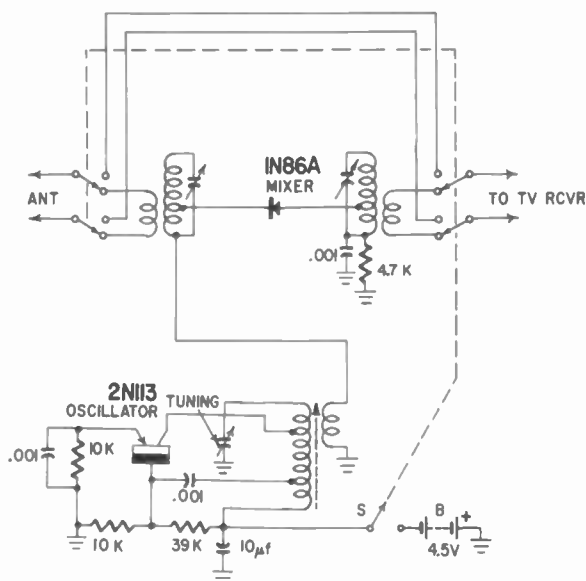

Fig. 612. FM converter for use with a TV receiver. This converter has a separate local oscillator and uses a diode as the mixer.

The converter is inserted in the lead-in between the antenna and the television receiver. Only four connections are required, input and output. To operate the converter, the TV set must be tuned to an unused channel. This channel is determined by the output frequency of the converter. The switch, S1-S2, is turned on and the FM stations are tuned in. This switch performs a dual purpose. It turns the converter on and then it inserts it into the antenna lead-in. When only the TV is to be used, the switch connects the antenna directly to the TV antenna terminals.

In servicing the converter, make sure that the trouble exists in the converter and not in the TV receiver which it feeds. Operating switch S1-S2 will soon indicate which of the two units, converter or receiver, is at fault. If, with the switch set in the FM position, TV signals come through but FM is not received, the transistor oscillator section consisting of T2, C4 and R2 may not be functioning. The TV signals received under such conditions may be weak and there may be difficulty in getting reception on all channels.

To check if the oscillator is functioning, connect an rf signal generator (no modulation) with the "hot" lead of the cable attached to the base of the converter and the ground lead to the

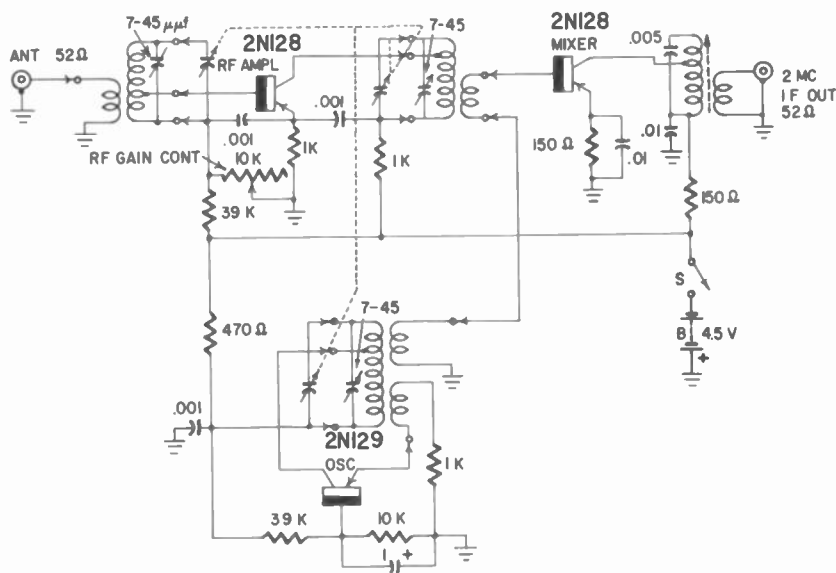

Fig. 613. Circuit diagram of a transistor shortwave converter. This arrangement uses separate transistors for the local oscillator and mixer. The output of the converter can be fed into a transistor receiver. The receiver must be tuned to the output frequency of the converter.

chassis. Use a 50 to 100- μf capacitor in series with the signal generator lead. The TV receiver station selector should be set to channel 3 with the fine tuning control adjusted for best picture reception. The receiver will now be tuned for wide-band reception of channel 3, including the picture signal frequency of 61.25 mc. Now select an FM station whose frequency you know (the FM station should be on the air when this test is made). Subtract 61.25 mc from the frequency of the FM station and set your signal

generator to this frequency. Vary the generator slightly above and below this frequency. If the FM station comes through, the oscillator section of the converter is at fault.

Another converter that performs the same function as the one

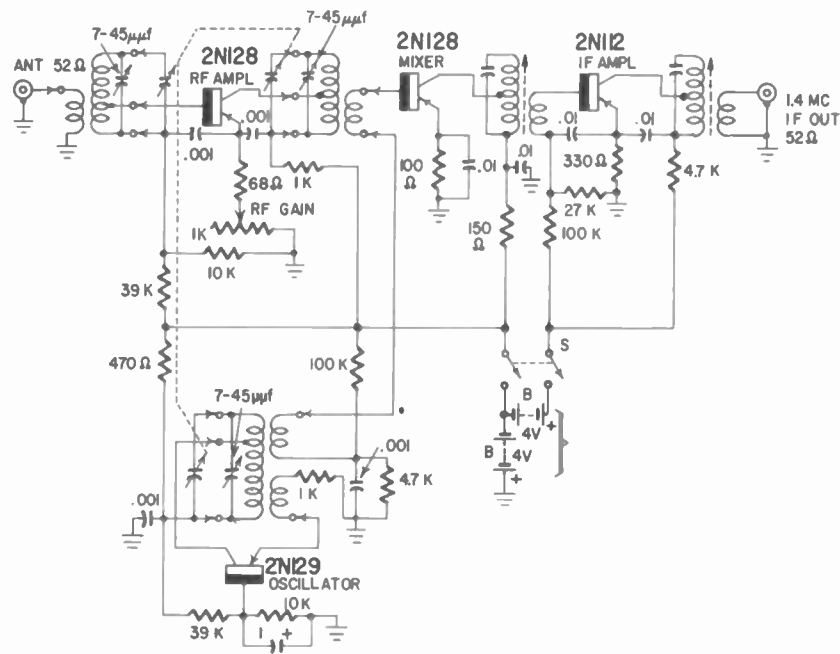

Fig. 614. Transistor amateur band converter. This unit is suitable for radiotelephone reception. For code, the receiver to which the converter is connected must have a beat-frequency oscillator.

just described, but with slightly different circuitry, is shown in Fig. 612. Here a diode is used as the mixer stage and a transistor as the oscillator. In this circuit the second-harmonic output of the oscillator is fed to the mixer. This has the advantage of providing for more stable operation of the converter and permitting use of a transistor whose cutoff frequency is 30 mc, one with a cutoff frequency of 15 mc can be used.

The disadvantage of this type of converter, though, lies in the fact that there is no conversion gain in the mixer stage since a diode is used. This converter requires the use of a television receiver with high sensitivity, or location in a strong signal area.

Two converters for shortwave and amateur radio use are shown in Figs. 613 and 614. These units use bandswitching to cover the required bands. Since reception of foreign or distant stations is of importance to the shortwave listener or the amateur, a stage of rf amplification is used to increase the sensitivity.

To prevent overload of the rf amplifier stage on strong signals, an rf gain control is used. It is placed in either the base-bias network or in the emitter circuit. Varying the control changes the base-emitter bias or the base-collector bias (depending upon the circuit used), which in turn varies the gain of the stage. Agc control is not used because the agc voltage developed by a vacuum-tube radio is of too high a value and of the wrong polarity. The agc voltage developed by a transistor radio is too low or of the wrong polarity. (The converter can be used to drive either a vacuum-tube or transistor receiver.)

The converter of Fig. 613 uses three p-n-p transistors as an rf amplifier, mixer and oscillator. The input signal frequency is from 1.6 to 30 mc, and the output frequency (if) is 2 mc. The sensitivity is 100 μv for an output of 3 millivolts at maximum rf gain. A single 9-volt battery supplies power at a current drain of 2.0 ma.

The converter of Fig. 614 uses four p-n-p transistors, three of which are of the surface-barrier type. These transistors are used as

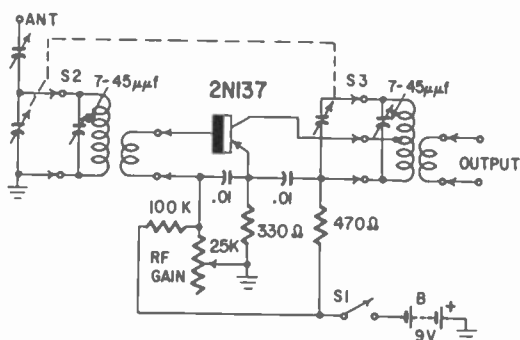

Fig. 615. Broadcast band and short-wave pre-selector. This unit is helpful in areas of low-signal strength. It will also improve the overall selectivity.

rf amplifier, mixer, oscillator and high-frequency if amplifier. The frequency coverage is from 1.6 to 55 mc, and the output frequency (if) is 1.4 mc. The sensitivity is 10 μv for an output of 10

mv at maximum rf gain. Two 4-volt mercury batteries in series are used to supply power at 4 volts for the surface-barrier transistors and 8 volts for the if transistor. The total maximum current drain is 3.5 ma.

Harmonic operation of the oscillator, above 20 mc, is used in both converters. This provides for better stability at the higher frequencies. The rf amplifier stage of both converters uses tuned input and output circuits for higher gain and better selectivity.

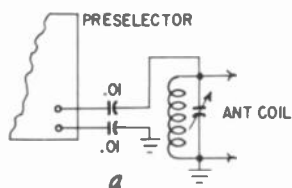

Fig. 616-a. The preselector can be capacitively coupled to a receiver.

Input and output line impedances for both units is 52 ohms, although 90-ohm line may be used without too noticeable a loss in gain.

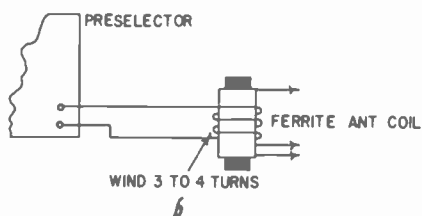

Fig. 616-b. Method for inductively coupling a preselector to a receiver.

Preselectors

A preselector is nothing more than an rf amplifier. It is used in conjunction with a radio to increase its sensitivity and boost the weak signals. At present the only preselectors available cover the broadcast and lower-frequency shortwave bands (up to 2.5 mc) with bandswitching.

Tuning of the preselector is separate from the tuning of the radio. Once a station is selected, the preselector is used to peak or boost the signal. The input and output circuits are both tuned for maximum gain.

To prevent overload, an rf gain control is used. It is connected

in the base-bias circuit and is used to vary the transistor gain. Although a ferrite-core loop antenna is used, provision is made for connecting an external antenna. No ground connection is needed.

Fig. 615 shows the schematic of the preselector, and Fig. 616 shows two ways in which it may be connected to the radio.

Solar power

The newest innovation among commercial transistor radios is one which uses a unique power source. The circuitry (Fig. 617) is that of a conventional superhet except for one important innovation—it is light-powered. The solar cells, however, are not used as the only power source. Being relatively low-current devices, a fairly complex bank of cells would have to be used to power a full-blown superhet complete with class-B audio output. This disadvantage is overcome by connecting the cells to a bank of rechargeable batteries. Under sunlight or bright artificial light, the cells charge the battery, which in turn operates the radio. A diode is inserted between the solar bank and the battery to prevent current flow from the battery, which might damage the light-sensitive units.

The relatively low current produced by the sun battery is thus “built up” by extended charging of the batteries. After the radio has been used indoors or in the shade for a period of time, the solar cells are exposed for several times that period. This replenishes the battery and extends its life almost indefinitely.

Transistor kits

By far the most popular of all the transistor equipment available on the market is the do-it-yourself kit. These kits even take precedence over the construction projects described in magazine articles. The kits range in complexity from simple one-stage audio amplifiers to complete nine-stage superheterodyne radios.

Although simple, easy-to-follow, step-by-step instructions are provided with the kits or described in magazine articles, there is often some foul-up of the wiring or assembly during construction.

Before attempting to service these units, make certain that you have the schematic diagram. Many a technician has been fooled by what seemed to be a conventional circuit only to find major differences in circuitry (after a few transistors have been blown) when checking with the schematic.

In servicing these units, first check the wiring. Compare it, point by point, with the schematic. After satisfying yourself that the wiring is correct, proceed to examine all components. Make sure

that they are of the proper value and are wired in their proper places. A wrong-value resistor or capacitor can result in an inoperative circuit or a damaged transistor.

Many times, too, you will find a cold solder joint or a rosin joint is the cause of the trouble. Therefore it is wise to examine all solder connections and resolder those that look suspicious. Remove all excess solder from connections. Often excess solder causes shorts that are not physically visible.

If acid-core has been used to construct the equipment, return it to the customer and inform him to remove this solder, clean all components thoroughly, and resolder with a good rosin-core radio solder. This is a precaution that is mostly for your benefit. Acid, in time, causes corrosion and deterioration of soldered joints and components. If you accept a kit that has been constructed with acid-core solder, the reaction that results can very easily be blamed on you and you will be forced to make restitution for damage that has resulted through no fault of your own.

The commonest faults in kits that use both p-n-p and n-p-n transistors is that they may be reversed in the circuit during construction. That is, an n-p-n transistor may be wired into a circuit that requires a p-n-p unit, and vice versa. When this happens, remove the transistors and test them for damage. If no damage has occurred, then place them in their proper circuits.

It is next to impossible to list here all the troubles that may, and do, occur in the construction of a transistor kit. Those described are typical and represent a major portion of the defects that do occur. Just about any of these kits, no matter how complex the circuit, can be serviced and repaired, provided the simple procedures outlined in this and in preceding chapters are followed.

All-wave radios

There are very definite indications that transistors will completely replace vacuum tubes in all-wave radio receivers. These new sets have many advantages over earlier vacuum-tube all-wave models. The use of transistors and subminiature components has greatly reduced weight and overall dimensions. Batteries for tube portables are bulky, heavy, expensive and often unavailable except through mail-order supply houses or the set manufacturers' outlet. Most of the new transistor portables use standard 1.5-volt flashlight cells that are small, inexpensive and available anywhere flashlights are used.

The light weight, small size and wide frequency range of these

sets make them ideal for travelers and tourists in foreign countries. They enable the owner to keep abreast of events and happenings in his homeland via shortwave radio broadcasts on the 31-, 25-, 19-, 16- and 13-meter bands.

Fishermen and operators of private pleasure boats can use these receivers for WWV time signals, weather reports and navigation information. Hams and SWL's can keep up with the goings-on on the most popular vhf amateur phone bands.

These all-wave transistor portables are generally equipped with telescopic whip antennas for shortwave reception, phone jacks, dial lights with momentary pushbutton switches for battery economy and either electrical or mechanical bandspread for easy tuning on the shortwave bands.

Some of these receivers use tuners with 2N370, 2N371 and 2N372 germanium p-n-p drift transistors designed for rf amplifier, oscillator and mixer service, respectively, at frequencies up to 23 mc. These transistors use shielding to minimize stray coupling and capacitance between adjacent leads.



tests and measurements

To determine the operating condition and characteristics of a transistor, the dc voltage and current at the base, collector and emitter electrodes must be measured. A given current is passed through one of these electrodes and the resulting voltage between that electrode and a reference electrode is measured. This is then compared with the specifications for the type of transistor under test.

The tests and measurements that will be described have been chosen as the most important in determining the true operation and worth of a suspected defective transistor. The polarities shown in the test circuits are correct for p-n-p units. If n-p-n transistors are to be tested, the circuit remains the same but the polarities are reversed.

To perform these tests and measurements, the following equipment is required:

- a) audio generator
- b) Rf signal generator
- c) Dc vacuum-tube voltmeter
- d) Ac vacuum-tube voltmeter
- e) 0-1/5/10/50 dc milliammeter (two required)
- f) 0-50/100/500 dc microammeter
- g) 0-1 dc ammeter
- h) Adjustable constant-current power supply—
maximum output 20 volts at 2 amperes
- i) Ohmmeter: $R \times 1$, $R \times 100$, $R \times 1,000$ and
 $R \times 10,000$ ohms ranges

For the adjustable constant-current power supplies (h), see Figs. 701 and 702. Values of resistance for R in Fig. 701 and for R1 and R2 in Fig. 702 cannot be supplied since these depend upon



Fig. 701. Constant-current power supply

the amount of dc voltage available. The series resistors (R and R2) should be as large as possible. The load to be placed across

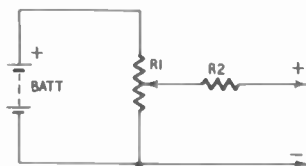

Fig. 702. Alternative arrangement of constant-current power supply.

the output (that is, connected to the plus and minus terminals of the constant-current supply) will be in series with R (in Fig. 701)

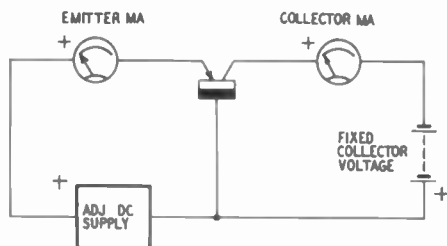

Fig. 703. Test circuit for measuring alpha of a transistor.

or in series with R2 (in Fig. 702). The resistance of the load will be negligible compared to the series resistance and as a result practically all voltage variations will exist as an IR drop across the series resistance. The result will be a constant voltage (or source of constant current) across the output terminals.

The voltage source can be a single battery, batteries in series or a dc power supply. R1 (in Fig. 702) permits a fine adjustment of

the output voltage. R1 also acts as a load on the voltage source, hence contributing to the stability of the voltage at the output.

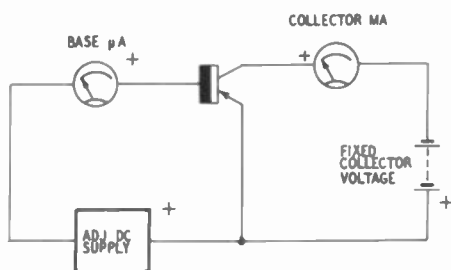

Fig. 704. Test circuit for measuring beta of a transistor.

The dc output voltage can be monitored by connecting a dc voltmeter across the output terminals. The unit shown in Fig. 702 is inexpensive and involves a minimum amount of equipment. The circuit of Fig. 701 assumes a power supply. The supply

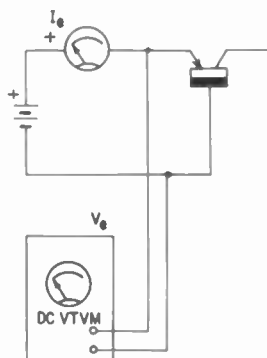

Fig. 705. Measuring input resistance.

should have good regulation and must have some means for controlling the dc output voltage.

Measuring alpha

Using the test circuit shown in Fig. 703, set the levels of emitter current and collector supply voltage at values selected from the transistor data sheets. Vary the emitter current (I_e) 0.1 ma above the selected value and note the corresponding change in collector current (I_c). Label these changes as I_{e1} and I_{c1} . Reduce the emitter current to 0.1 ma below the selected value and again note the

corresponding change in collector current. Label these changes as I_{e2} and I_{e1} . Now, with these values of I_e and I_c , the value of alpha can be determined from the formula

$$\alpha = \frac{I_{c2} - I_{c1}}{I_{e2} - I_{e1}}$$

To obtain complete data showing the variation of alpha, these measurements may be made at different values of collector supply voltage and emitter current, using the same parameters.

Measuring beta

Using the test circuit shown in Fig. 704, set the levels of base current and collector supply voltage at values selected from the

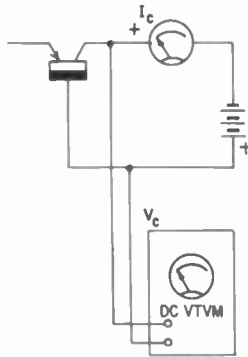

Fig. 706. *Measuring output resistance.*

transistor data sheets. Vary the base current (I_b) 20 to 100 microamperes (depending upon the transistor) above the selected value and note the corresponding change in collector current (I_c). Label these changes as I_{b1} and I_{c1} . Reduce the base current 20 to 100 μa below the selected value and again note the change in collector current. Label these changes as I_{b2} and I_{c2} . With these values of I_b and I_c , beta can be determined from the formula

$$\beta = \frac{I_{c2} - I_{c1}}{I_{b2} - I_{b1}}$$

As with the measurement of alpha, complete data showing the

variation of beta may be obtained by using different values of collector supply voltage and base current, using the same parameters.

Measuring transistor resistances

Using the test circuits shown in Figs. 705, 706, 707, and 708 the input, output, feedback and transfer resistances of a transistor may

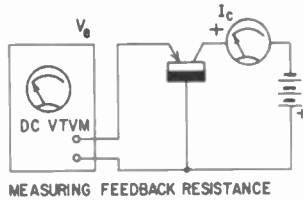

Fig. 707. Measuring feedback resistance.

be measured. Using the circuit of Fig. 705, the value of input resistance may be determined by the formula

$$R_{in} = \frac{V_e}{I_e} \text{ (collector open)}$$

V_e is the emitter voltage and I_e is the emitter current.

To determine output resistance, the circuit in Fig. 706 is used with the formula

$$R_{out} = \frac{V_c}{I_c} \text{ (emitter open)}$$

V_c is the collector voltage and I_c is the collector current.

To determine feedback resistance, the circuit in Fig. 707 is used with the formula

$$R_f = \frac{V_e}{I_c} \text{ (emitter open)}$$

To determine transfer resistance, the circuit in Fig. 708 is used with the formula

$$R_t = \frac{V_c}{I_e} \text{ (collector open)}$$

The values of I_e , I_c , V_c and V_e are chosen from the transistor characteristic data sheets and do not necessarily have to be taken at

more than one point. From them the emitter, collector and mutual resistances can be calculated as well as the value of alpha. These formulas are:

$$\begin{aligned} \text{emitter resistance} &= \text{input resistance} - \text{feedback resistance} \\ \text{collector resistance} &= \text{output resistance} - \text{feedback resistance} \\ \text{mutual resistance} &= \text{transfer resistance} - \text{feedback resistance} \\ \alpha &= \text{transfer resistance} / \text{output resistance} \end{aligned}$$

Grounded-emitter characteristics

This test is used to determine the operating characteristics of a suspected defective transistor. It is comparable to the dynamic

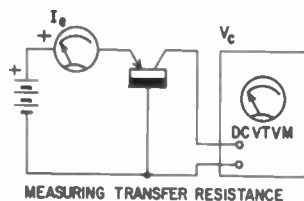

Fig. 708. *Measuring transfer resistance.*

test of a vacuum tube and actually duplicates the manufacturer's characteristics curves for the transistor in the grounded-emitter configuration.

The test circuit is shown in Fig. 709. With no current applied

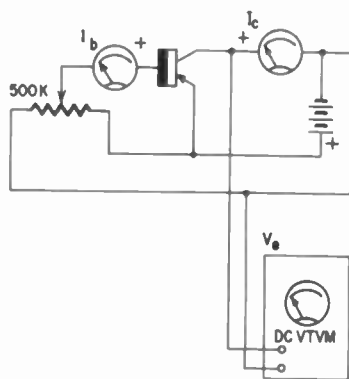

Fig. 709. *Determining grounded-emitter characteristics.*

to the base, increase the collector voltage in steps according to the data sheets. As the collector voltage is increased, note the values

of collector current obtained and compare with those on the data sheets. Increase the value of base current from zero to the next value and once again compare collector voltage and current. Con-

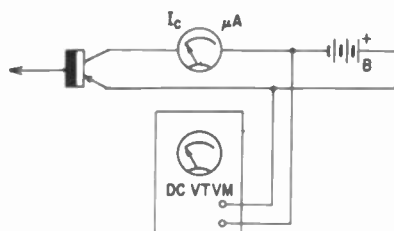

Fig. 710. Test circuit for determining collector-current cutoff.

tinue this process for each value of base current, noting with each increase in collector voltage the value of collector current. A good

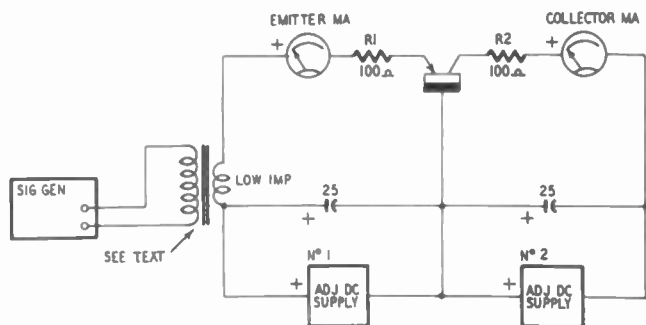

Fig. 711. Test circuit for determining the alpha-cutoff frequency of a transistor.

transistor should fall within 10% of the manufacturer's values. If it does not, then the transistor should be considered defective.

Collector-current cutoff

Using the test circuit shown in Fig. 710, the value of collector current at cutoff can be determined. It is important because it is the leakage current between the emitter and collector with no forward bias applied to the emitter diode and no current flowing through the base circuit. If its value is high, then the transistor is no longer able to perform satisfactorily. The maximum limit beyond the manufacturer's rating should not exceed 5%. Anything beyond this means that under heat the transistor current will run away.

Measuring alpha-cutoff frequency

Apply a 1,000-cycle signal, at a level of 0.25 volt rms, to the primary winding of the transformer in the test circuit shown in Fig. 711. Set the values of I_b and I_c at the levels selected from the transistor data sheets. Measure the voltages across resistors R_1 and R_2 . Their ratio (E_2 to E_1) gives the value of alpha. Use this value as the 0-db reference point. Increase the frequency of the generator until the value of alpha (or the ratio of E_2 to E_1) drops to a point that is 3 db (0.707) below the 1,000-cycle reference value.

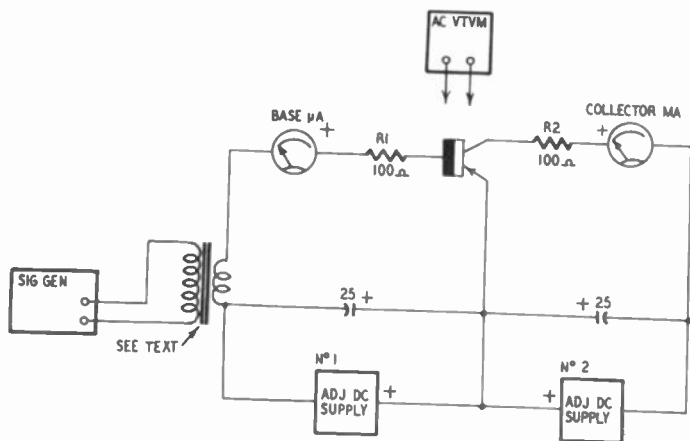

Fig. 712. Test circuit for determining the beta-cutoff frequency of a transistor.

The frequency at which this drop occurs is the alpha-cutoff frequency and is the maximum usable frequency at which the gain of the transistor is constant. If this frequency enters into the rf range, then it will be necessary to change the audio transformer to an rf unit. When changing transformers, keep the secondary impedances and dc resistances as close and constant as possible.

When changing or increasing frequency, the generator voltage must be held at a constant value. It should not be allowed to increase or decrease; otherwise erroneous readings will result. An easy way is to monitor the output of the generator with a calibrated scope. A vtvm capable of reading low volts ac (1 volt rms full scale deflection) will also do.

Measuring beta-cutoff frequency

Except for the test circuit (Fig. 712), the method of measuring beta-cutoff frequency is the same as that just described. The gen-

erator output should be approximately 0.1 volt. The beta-cutoff frequency will occur at a frequency well below alpha cutoff.

Quick check method

A transistor may be checked for shorts or opens by using an ohm-

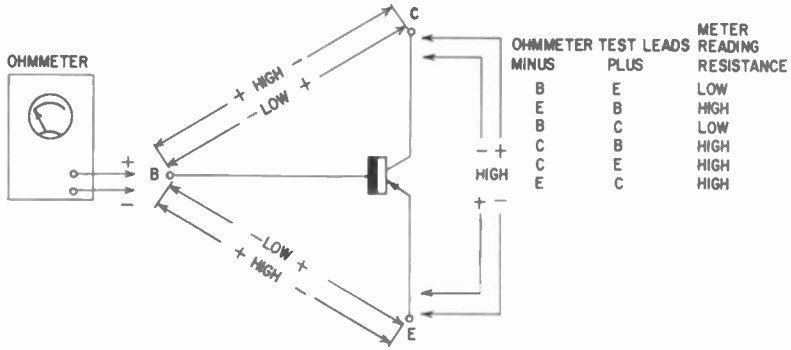

Fig. 713. Quick-check method for testing transistors.

meter. This check simply measures the ability of a transistor to conduct current in one direction and resist it in the opposite direc-

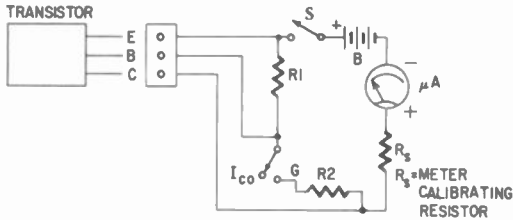

Fig. 714. Transistor tester used to determine I_{co} and beta.

tion. The resistance in the forward (conduction) direction is low compared to the resistance in the opposite direction. This check is made as shown in Fig. 713.

This method should not be used with transistors whose maximum collector voltage and current are low. The ohmmeter should not deliver more than 2 ma and the voltage present between the test leads must not exceed 3 volts. A vacuum-tube ohmmeter (vtvm) is preferred.

Transistor testers

Transistor testers are used to provide a quick check on the condition of a suspected defective transistor. Passing over the more

obvious defects such as opens and shorts, these testers indicate the possible causes of deterioration. These include the amount of current flowing through the collector at cutoff and the approximate values of alpha and beta. Some testers make use of a bridge circuit to measure current gain.

The tester shown in Fig. 714 measures the collector-cutoff current and determines the approximate value of beta. Since the majority of transistors are used in grounded-emitter circuits, the tester makes use of this configuration to determine the worth of the transistor tested. When the switch is placed in the I_{co} position, collector-cutoff current is measured. This is then compared

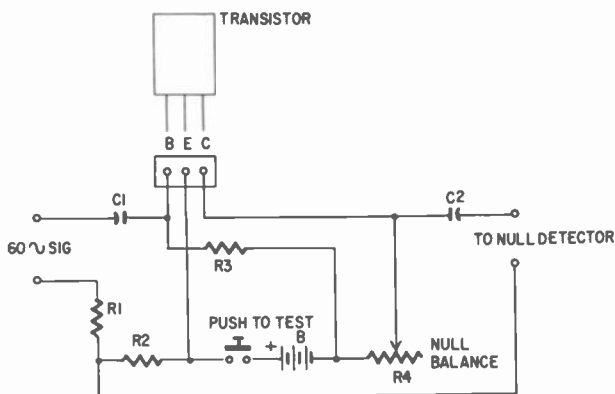

Fig. 715. Bridge-type transistor tester to measure low frequency current gain (beta).

with the manufacturer's data sheets. Switching to position G, the beta of the transistor is measured, and this also is compared with the data sheets. Any great change from normal in these readings, as indicated in the data sheets, indicates a poor or defective transistor.

The tester in Fig. 715 is used to measure the current gain of a transistor by comparing its input and output signals. It uses a bridge circuit. By applying a known 60 cycle voltage to the base of the transistor and sampling the input and output signals and comparing them, the approximate actual value of beta is determined. The balance control (R4) is used to null the bridge. This control is calibrated in values of beta and, when the bridge is nulled or balanced, the value of beta is read directly off the dial.

Alpha-beta conversion chart

Many transistor characteristic data sheets give only the value of

either alpha or beta. Since alpha is the current gain of a transistor in the grounded-base circuit and beta its value in the grounded-emitter circuit, knowing one only is of no help in designing or determining the current gain of an amplifier in a given circuit. However, if one value is known, the other may be calculated from the following formulas:

$$\alpha = 1 - (1/\beta + 1)$$

$$\beta = \alpha / (1 - \alpha)$$

To simplify calculation, Table 7-1 can be used to convert values of alpha to values of beta and vice versa.

Table 7-1. Alpha-Beta Conversion Chart

Alpha	Beta	Alpha	Beta	Alpha	Beta
0.500	1	0.978	45	0.9931	130
0.670	2	0.980	50	0.9932	140
0.750	3	0.982	55	0.9933	150
0.800	4	0.984	60	0.9938	160
0.835	5	0.985	65	0.9942	170
0.859	6	0.986	70	0.9945	180
0.875	7	0.987	75	0.9948	190
0.889	8	0.9875	80	0.9952	200
0.900	9	0.988	85	0.9954	210
0.910	10	0.9889	90	0.9956	220
0.938	15	0.989	95	0.9958	230
0.952	20	0.990	100	0.996	240
0.967	30	0.991	110	0.9962	250
0.972	35	0.992	120	0.9963	260
0.975	40	0.993	125	0.9964	270

The various tests described in this chapter show measurements being made with p-n-p transistors. N-p-n units can also be tested but remember to transpose battery voltages and meter leads.

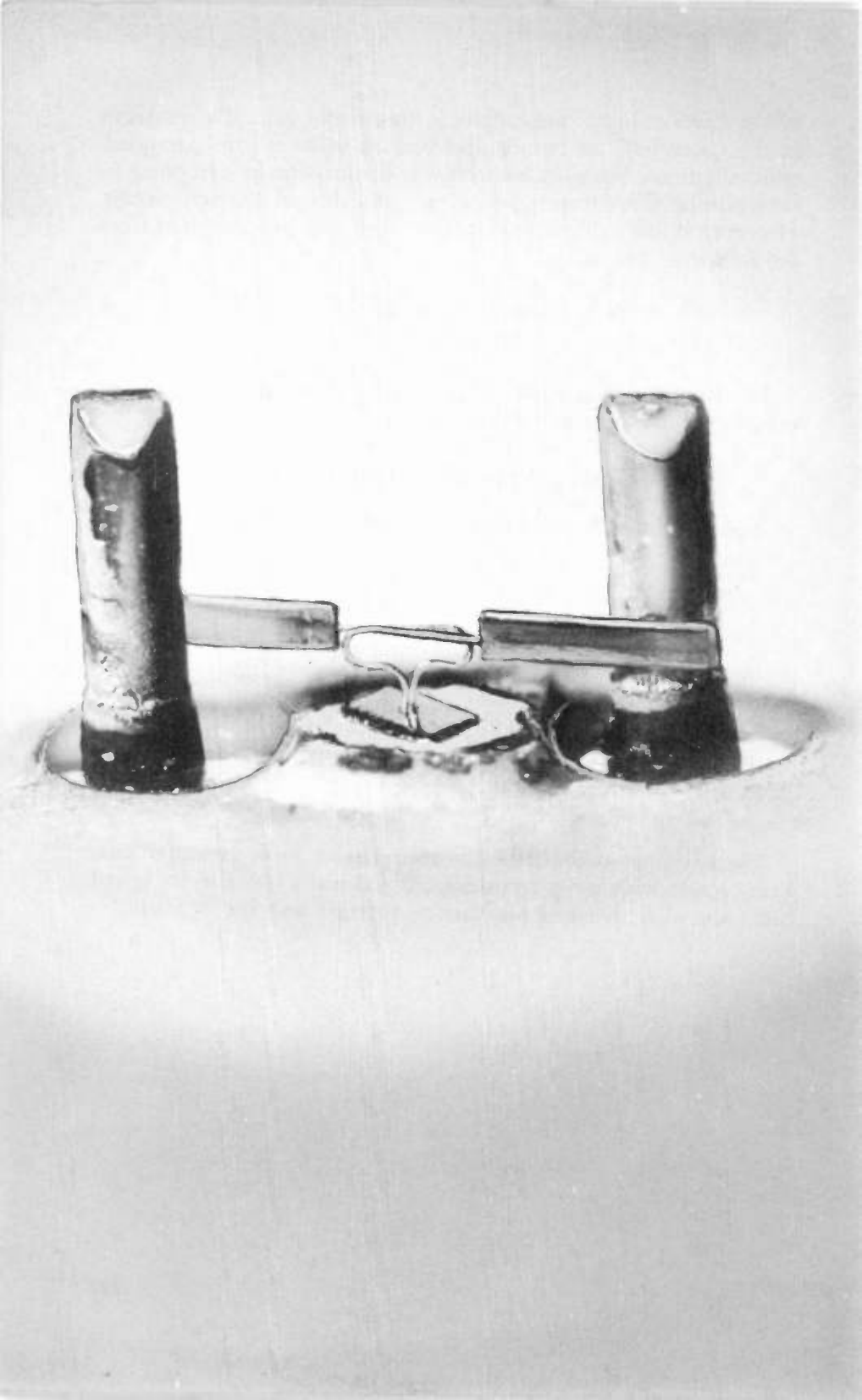

transistor data

THE transistors and characteristics listed are those most commonly used in radios and related equipment. They are listed as a matter of convenience and for identification only. All information is based upon available published data. The following abbreviations are used in the chart.

Column Heading	Description
A	Application: 1. Rf amplifier 2. If amplifier 3. Converter 4. Oscillator 5. Af amplifier 6. Af output 7. Power output 8. Reflex amplifier 9. Detector
$f_{\alpha_{co}}$	Alpha-cutoff frequency, in megacycles
α/β	Current Gain: α , alpha; β , beta
PG	Matched power gain, in db, grounded-emitter configuration
V_c	Collector voltage
I_c	Collector current, in milliamperes
I_{co}	Collector cutoff current, in microamperes
P_{diss}	Collector dissipation, in milliwatts

In the column headed Type, s-b stands for surface barrier. Its biasing is the same as that for a p-n-p transistor.

Wherever a blank space appears in the data listed, the information was not available. Complete data and information on any particular transistor should be obtained from the manufacturer or his representative.

Number	Type	A	$f_{\alpha_{co}}$	a/β	PG	V_c	I_c	I_{co}	P_{diss}
2N34	p-n-p	5	0.6	40	40	-25	-8	5	50
2N35	n-p-n	5	0.8	40	40	25	8	5	50
2N36	p-n-p	5	—	45	40	-20	-8	—	—
2N37	p-n-p	5	—	30	36	-20	-8	—	—
2N38	p-n-p	5	—	15	32	-20	-8	—	—
2N38A	p-n-p	5	—	18	32	-20	-8	—	—
2N41	p-n-p	5	—	40	40	-25	-15	—	—
2N44	p-n-p	5,6	1.0	0.970	43	-30	-50	15	150
2N46	p-n-p	5	—	40	40	-25	-15	—	—
2N47	p-n-p	5	—	0.975	40	-35	-20	5	50
2N48	p-n-p	5	—	0.975	40	-35	-20	5	50
2N49	p-n-p	5	—	0.975	40	-35	-20	5	50
2N63	p-n-p	5	0.6	22	39	-22	-10	6	100
2N64	p-n-p	5	0.8	45	41	-15	-10	6	100
2N65	p-n-p	5	1.2	90	42	-12	-10	6	100
2N68	p-n-p	7	0.4	40	23	-25	-1.5*	—	2-4†
2N76	p-n-p	5	1.0	20	38	-20	-10	—	50
2N77	p-n-p	5	0.7	55	44	-25	-15	—	35
2N78	n-p-n	1	3.7	58	26	15	20	6	65
2N79	p-n-p	5	0.7	46	44	-30	-50	—	35
2N80	p-n-p	5	—	80	—	-25	-8	8	50
2N81	p-n-p	5	—	30	—	-20	-15	—	50
2N82	p-n-p	5	—	30	—	-20	-15	—	35
2N94	n-p-n	2	3.5	0.970	38	30	10	3	50
2N94A	n-p-n	1,2	6.0	0.970	40	30	10	3	50
2N95	n-p-n	7	0.4	40	23	25	1.5*	—	2.5-4†
2N101	p-n-p	7	—	—	23	-25	-1.5*	—	1
2N102	n-p-n	7	—	—	—	25	1.5*	—	1
2N104	p-n-p	5	0.7	44	33	-30	-50	—	150
2N105	p-n-p	5	0.75	55	42	-25	-15	—	50
2N106	p-n-p	5	0.8	45	36	-6	-10	1	100
2N107	p-n-p	5	1.0	20	38	-12	-10	10	50
2N108	p-n-p	6	—	—	—	-20	-15	—	50
2N109	p-n-p	6	—	70	33	-12	-35	—	50

Number	Type	A	$f_{\alpha_{co}}$	a/β	PG	V_c	I_c	I_{co}	P_{diss}
2N111	p-n-p	4	3.0	40	33	-6	-5	5	100
2N111A	p-n-p	4	3.0	40	33	-6	-5	5	100
2N112	p-n-p	1,2	5.0	40	32	-6	-5	5	100
2N113	p-n-p	1	10.0	45	33	-6	-5	1	100
2N114	p-n-p	1	20.0	65	38	-6	-5	1	100
2N116	p-n-p	5	—	—	—	—	—	—	—
2N128	s-b	1,3,4	65.0	28	—	-10	-5	15	30
2N129	s-b	1,3,4	60.0	20	—	-10	-5	15	30
2N130	p-n-p	2,5	0.8	22	39	-22	-10	6	100
2N131	p-n-p	2,5	0.8	45	41	-15	-10	6	100
2N132	p-n-p	2,5	1.0	90	42	-12	-10	6	100
2N133	p-n-p	2	0.8	25	36	-15	-10	12	100
2N135	p-n-p	2	4.5	20	29	-20	-50	5	100
2N136	p-n-p	1	6.5	40	31	-20	-50	5	100
2N137	p-n-p	1	10.0	60	33	-10	-50	5	100
2N138	p-n-p	6	—	140	30	-12	-20	6	50
2N138A	p-n-p	6	—	40	35	-30	-100	6	50
2N139	p-n-p	2	7.0	48	39	-16	-15	6	80
2N140	p-n-p	3	10.0	75	32	-16	-15	6	80
2N141	p-n-p	7	0.4	40	26	-30	-800	—	1.5-4†
2N142	n-p-n	7	0.4	40	26	30	800	—	1.5-4†
2N143	p-n-p	7	0.4	40	26	-30	-800	—	1.5-4†
2N144	n-p-n	7	0.4	40	26	30	800	—	1.5-4†
2N145	n-p-n	2	—	—	33	20	5	3	65
2N146	n-p-n	2	—	—	36	20	5	3	65
2N147	n-p-n	2	—	—	39	20	5	3	65
2N148	n-p-n	2	—	—	32	16	5	3	65
2N148A	n-p-n	2	—	—	32	32	5	3	65
2N149	n-p-n	2	—	—	35	16	5	3	65
2N149A	n-p-n	2	—	—	35	32	5	3	65
2N150	n-p-n	2	—	—	38	16	5	3	65
2N150A	n-p-n	2	—	—	38	32	5	3	65
2N155	p-n-p	7	0.14	45	30	-30	-3*	180	1.5-7.5†
2N156	p-n-p	7	0.18	45	36	-30	-3*	180	1.5-7.5†
2N158	p-n-p	7	0.18	41	40	-60	-3*	140	1.5-7.5†
2N164A	n-p-n	4	8.0	40	39	15	20	—	65
2N165	n-p-n	2	5.0	72	36	15	20	—	65
2N166	n-p-n	2	5.0	32	24	6	20	—	25
2N168	n-p-n	1	6.0	20	39	15	20	—	55
2N168A	n-p-n	4	8.0	40	39	15	20	—	65
2N169	n-p-n	9	4.0	40	—	15	20	6	50

Number	Type	A	$f_{a_{co}}$	α/β	PG	V_c	I_c	I_{co}	P_{diss}
2N169A	n-p-n	8,9	5.0	30	35	25	20	6	55
2N170	n-p-n	4	4.0	20	12	6	20	5	25
2N172	n-p-n	3	—	—	28	16	5	3	65
2N173	p-n-p	7	0.004	100	43*	-60	-13*	120	35†
2N174	p-n-p	7	0.004	65	—	-80	-13*	120	35†
2N175	p-n-p	5	0.85	65	43	-10	-2	12	20
2N176	p-n-p	7	—	—	25	-12	-600	—	5†
2N178	p-n-p	7	—	30	29	-12	-600	—	5†
2N179	p-n-p	7	—	—	32	-20	-60	—	—
2N180	p-n-p	6	0.6	65	43	-30	-25	10	150
2N181	p-n-p	6	0.6	65	43	-30	-38	10	250
2N182	n-p-n	2	2.5	25	—	25	10	3	100
2N183	n-p-n	2,3	5.0	40	—	25	10	3	100
2N185	p-n-p	6	—	55	40	-20	-150	8	150
2N186	p-n-p	6	0.8	24	28	-25	-200	16	75
2N186A	p-n-p	6	0.8	24	28	-25	-200	16	180
2N187	p-n-p	6	1.0	36	30	-25	-200	16	75
2N187A	p-n-p	6	1.0	36	30	-25	-200	16	180
2N188	p-n-p	6	1.2	54	32	-25	-200	16	75
2N188A	p-n-p	6	1.2	54	32	-25	-200	16	180
2N189	p-n-p	5	0.8	24	37	-25	-50	16	75
2N190	p-n-p	5	1.0	36	39	-25	-50	16	75
2N191	p-n-p	5	1.2	54	41	-25	-50	16	75
2N192	p-n-p	5	1.5	75	43	-25	-50	16	75
2N193	n-p-n	4	3.0	6	—	15	50	—	50
2N194	n-p-n	4	3.5	7.5	—	15	50	—	50
2N206	p-n-p	5	0.78	47	46	-30	-50	10	75
2N207	p-n-p	5	2.0	65	—	-20	-20	5	25
2N207A	p-n-p	5	2.0	65	—	-20	-20	5	25
2N207B	p-n-p	5	2.0	65	—	-20	-20	5	25
2N211	n-p-n	4	3.5	30	—	10	50	—	50
2N212	n-p-n	4	6.0	15	—	10	50	—	50
2N213	n-p-n	5,6	—	150	42	25	100	200	50
2N214	n-p-n	6	0.8	70	29	25	75	—	125
2N215	p-n-p	5	0.7	44	33	-30	-50	10	150
2N216	n-p-n	2	3.0	15	26	15	50	40	50
2N217	p-n-p	6	—	70	33	-12	-35	—	50
2N218	p-n-p	2	7.0	48	39	-16	-15	6	80
2N219	p-n-p	3	10.0	75	32	-16	-15	6	80
2N220	p-n-p	5	0.85	65	43	-10	-2	12	20
2N223	p-n-p	5	0.6	50	37	-18	-16	—	100

Number	Type	A	$f_{\alpha_{co}}$	a/β	PG	V_c	I_c	I_{co}	P_{dIRN}
2N224	p-n-p	6	0.5	75	36	-25	-150	-	100
2N225	p-n-p	6	0.5	75	36	-25	-150	-	100
2N226	p-n-p	6	0.4	55	30	-25	-150	-	100
2N227	p-n-p	6	0.4	55	30	-25	-150	-	100
2N228	n-p-n	6	0.8	100	26	25	25	200	50
2N229	n-p-n	5	1.6	25	-	12	40	-	50
2N238	p-n-p	5	-	-	42	-20	-	8	50
2N241	p-n-p	6	1.6	60	34	-25	-200	-	100
2N241A	p-n-p	6	1.6	60	34	-25	-200	-	180
2N242	p-n-p	7	0.005	40	30	-45	-2*	5 [§]	-
2N247	p-n-p	1	30.0	60	45	-35	-10	16	80
2N252	p-n-p	3	-	-	30	-16	-5	10	30
2N253	n-p-n	2	-	-	32	12	5	3	65
2N254	n-p-n	2	-	-	36	20	5	3	65
2N255	p-n-p	7	0.2	40	23	-15	-3*	-	1.5-6.25 [†]
2N256	p-n-p	7	0.2	40	26	-30	-3*	-	1.5-6.25 [†]
2N267	p-n-p	1	30.0	60	45	-35	-10	16	80
2N277	p-n-p	7	0.004	60	34	-40	-12*	120	55 [†]
2N278	p-n-p	7	0.004	60	34	-50	-12*	120	55 [†]
2N292	n-p-n	2	6.0	80	35	15	20	-	55
2N293	n-p-n	1	4.0	35	39	15	20	-	55
2N301	p-n-p	7	-	75	32	-40	-1*	220	12 [†]
2N301A	p-n-p	1	-	75	32	-60	-1*	220	12 [†]
2N313	n-p-n	2	5.0	25	36	15	20	5	65
2N314	n-p-n	2	8.0	25	30	15	20	5	65
2N319	p-n-p	6	3.0	36	30	-20	-200	-	200
2N320	p-n-p	6	3.0	54	32	-20	-200	-	200
2N321	p-n-p	6	3.0	73	35	-20	-200	-	200
2N322	p-n-p	5	3.0	36	39	-16	-50	-	75
2N323	p-n-p	5	3.0	54	41	-16	-50	-	75
2N324	p-n-p	5	3.0	75	43	-16	-50	-	75
2N325	p-n-p	5	3.0	40	-	-35	-2*	-	12 [†]
2N344	s-b	1	50.0	33	-	-5	-5	5	20
2N345	s-b	1	50.0	110	-	-5	-5	5	20
2N346	s-b	1	75.0	10	-	-5	-5	5	20
2N370	p-n-p	1	30.0	60	12	-20	-10	20	80
2N371	p-n-p	4	30.0	40	-	-30	-10	20	80
2N372	p-n-p	3	30.0	60	50	-20	-10	16	80
2N384	p-n-p	1	100.0	60	34	-20	-10	16	120
2N409	p-n-p	2	6.8	45	39	-12	-15	10	80
2N410	p-n-p	2	6.8	45	39	-12	-15	10	80

Number	Type	A	$f_{a_{co}}$	α/β	PG	V_c	I_c	I_{co}	P_{diss}
2N411	p-n-p	3	10.0	75	32	-12	-15	10	80
2N412	p-n-p	3	10.0	75	32	-12	-15	10	80
2N413	p-n-p	1	3.0	40	33	-30	-200	1	150
2N414	p-n-p	2	5.0	40	18	-30	-200	1	150
2N415	p-n-p	3	10.0	45	36	-30	-200	1	150
CK721	p-n-p	5	0.8	45	41	-15	-10	6	150
CK722	p-n-p	5	0.6	22	39	-22	-10	6	150
CK725	p-n-p	5	0.8	90	42	-12	-10	6	100
CK727	p-n-p	5	1.0	25	36	-6	-10	6	30
CK751	p-n-p	6	0.8	40	28	-30	-100	6	—
CK759	p-n-p	4	3.0	40	33	-6	-5	5	100
CK760	p-n-p	1,2	5.0	40	32	-6	-5	5	100
CK761	p-n-p	1	10.0	45	33	-6	-5	5	100
CK762	p-n-p	1	20.0	65	38	-6	-5	1	100
CK766	p-n-p	1	10.0	45	29	-30	-200	5	—
CK766A	p-n-p	2	10.0	45	30	-30	-200	5	—
CK768	p-n-p	2,3	2.5	20	27	-30	-100	1	—
OC70	p-n-p	5	0.3	40	30	-15	-10	12	125
OC71	p-n-p	5	0.3	76	40	-15	-10	12	125
OC72†	p-n-p	6	0.35	120	23	-12	-125	10	150
OC73	p-n-p	5	0.5	55	—	-30	-10	6	125
AO-1	s-b	4	30.0	15	—	-4.5	-5	10	10
SB-100	s-b	1	45.0	20	—	-4.5	-5	0.5	10
T-1013	p-n-p	6	0.6	95	—	-18	-150	—	100
T-1067	p-n-p	6	0.6	95	—	-9	-60	—	50
L5022	p-n-p	6	0.6	63	—	-6	-150	—	90
L5022A/ T1044	p-n-p	6	—	78	—	-25	-150	—	100
L5113L/ T1033	s-b	3,4	30.0	42	—	-4.5	-3	—	10
L5114A/ T1046	s-b	2	20.0	24	—	-4.5	-3	—	10

* In amperes.

† In watts. Second figure is dissipation with use of heat sink.

‡ In milliamperes.

¶ This type number is given to matched-pair transistors. Ratings given, except for PG, are for individual units: One defective transistor requires replacement of both.

Transistor interchangeability chart

There are times when an identical replacement for a defective transistor is not available. Ordering and waiting for a replacement

may take several weeks; a delay which can be upsetting to customer and technician alike. To aid the service technician in situations such as this the interchangeability chart has been prepared.

It is definitely *not* wise to substitute or interchange transistor types. However sometimes circumstances dictate what can and cannot be done. Knowledge and experience are the guides which determine the proper course of action to follow.

The interchangeability of the transistors listed in the chart is based upon the similarity of electrical parameters as obtained from available characteristic data sheets. Only those types used in radios and associated equipment are included. In some cases the substitute transistor differs physically from the original. The difference in size and shape does not affect performance. The choice of the type to use is left to the discretion of the service technician.

Every effort has been made to keep this chart as accurate as possible. But, because the manufacturing techniques of all makers are not the same, no guarantee can be made as to the compatibility and interchangeability of the transistors listed. In many cases, except for those units which are cross-indexed, transistors can be interchanged in only one direction. That is, transistors listed under the heading *closest replacement* can be substituted for the corresponding unit in the *number* column. Do not substitute in the opposite direction.

As a precaution, it is best to insert a milliammeter in the collector circuit and monitor the collector current to be certain that current and dissipation ratings are not exceeded. If a substitute transistor does not function *do not* alter the circuit to accommodate the replacement unless the procedure is recommended by the manufacturer.

The transistor number, the primary use for which the unit was designed, the type and the closest replacement are listed. For further information on a particular transistor the characteristics chart at the beginning of this chapter should be examined. For detailed information on special applications the manufacturer or his representative should be consulted.

Number	Type	Function	Closest Replacement
2N34	p-n-p	Af	2N41; 2N46; 2N47; 2N49; 2N109; 2N190; 2N322; 2N362; 2N363 GT20 WTV-AT6; WTV-AT6A

Number	Type	Function	Closest Replacement
2N35	n-p-n	Af	2N169A GT35
2N36	p-n-p	Af	2N64; 2N79; 2N104; 2N191; 2N206; 2N215; 2N238; 2N323 GT20 WTV-3mc
2N37	p-n-p	Af	2N34; 2N41; 2N46; 2N190; 2N322 GT14 WTV-20V-MG; WTV-30V-MG
2N38	p-n-p	Af	2N38A; 2N45; 2N81; 2N138A; 2N189 GT34 WTV-20V-LG; WTV-30V-LG
2N38A	p-n-p	Af	2N38; 2N45; 2N81; 2N138A; 2N189
2N41	p-n-p	Af	2N34; 2N46; 2N47; 2N49; 2N104; 2N109; 2N322 GT14 WTV-30V-MG
2N44	p-n-p	Af	2N43; 2N43A WTV-B5
2N45	p-n-p	Af	2N38; 2N81; 2N138A; 2N189
2N46	p-n-p	Af	2N34; 2N41; 2N47; 2N49; 2N104; 2N109; 2N190; 2N322
2N47	p-n-p	Af	2N34; 2N41; 2N46; 2N49; 2N109; 2N190; 2N322; 2N359; 2N360; 2N361 WTV-B5; WTV-B5A

Number	Type	Function	Closest Replacement
2N49	p-n-p	Af	2N34; 2N41; 2N46; 2N47; 2N104; 2N109; 2N190; 2N322; 2N359; 2N360; 2N361 WTV-B5; WTV-B5A
2N63	p-n-p	Af	2N34; 2N41; 2N46; 2N47; 2N104; 2N109; 2N190; CK722 GT14 WTV-30V-LG
2N64	p-n-p	Af	2N36; 2N79; 2N104; 2N105; 2N131; 2N191; 2N206; 2N215; 2N238; 2N323 CK721 GT20 WTV-B5; WTV-B5A
2N65	p-n-p	Af	2N132; 2N192; 2N265; CK725 GT81 WTV-B5; WTV-B5A
2N68	p-n-p	Power	2N101; 2N155; 2N156; 2N158; 2N255; 2N256; 2N301; 2N301A; 2N325
2N76	p-n-p	Af	2N63; 2N107; 2N130; 2N190 CK722 GT14
2N77	p-n-p	Af	2N105; 2N185; 2N191; 2N220; 2N265; 2N323; 2N324; 2N359; 2N360; 2N361; 2N565 WTV-B5; WTV-B5A
2N78	n-p-n	Rf	2N94A; 2N170; 2N445

Number	Type	Function	Closest Replacement
2N79	p-n-p	Af	2N77; 2N105; 2N185; 2N191; 2N206; 2N215; 2N238; 2N323 GT20
2N80	p-n-p	Af	2N65; 2N132; 2N175; 2N192; 2N217; 2N220; 2N223; 2N324 GT81
2N81	p-n-p	Af	2N48; 2N82 GT14
2N82	p-n-p	Af	2N48; 2N81 GT14
2N94	n-p-n	Rf	2N94A; 2N169A GT948R
2N94A	n-p-n	Rf	2N169A GT792R
2N95	n-p-n	Power	2N102; 2N142; 2N144
2N101	p-n-p	Power	2N68; 2N141; 2N143
2N102	n-p-n	Power	2N95; 2N142; 2N144
2N104	p-n-p	Af	2N191; 2N206; 2N215 2N362; 2N363; 2N565 WTV-AT6; WTV-AT6A
2N105	p-n-p	Af	2N65; 2N132; 2N191; 2N192; 2N206; 2N220; 2N324 GT81 WTV-3OV-MG
2N106	p-n-p	Af	2N79; 2N191; 2N192; 2N323; 2N359; 2N360; 2N361 WTV-B5; WTV-B5A
2N107	p-n-p	Af	2N63; 2N76; 2N130; 2N190; 2N362; 2N363 CK722

Number	Type	Function	Closest Replacement
2N107 (continued)			GT222 WTV-20V-LG; WTV-AT6
2N108	p-n-p	Af	*
2N109	p-n-p	Af	2N180; 2N181; 2N224; 2N225; 2N270; 2N321; 2N359; 2N360; 2N361 GT109 WTV-B5; WTV-B5A
2N111	p-n-p	If	2N111A; 2N123; 2N135; 2N482; 2N483; 2N519 WTV-BA6; WTV-BA6A
2N111A	p-n-p	If	2N111; 2N123; 2N135; 2N482; 2N483
2N112	p-n-p	Rf	2N112A; 2N113; 2N136; 2N137; 2N409; 2N410; 2N482; 2N483; 2N485; 2N486; 2N520 CK760 WTV-6mc; WTV-12mc; WTV-20mc
2N112A	p-n-p	Rf	2N112; 2N113; 2N136; 2N137; 2N482; 2N483 CK760
2N113	p-n-p	Rf	2N114; 2N137; 2N521 CK761 WTV-12mc; WTV-20mc
2N114	p-n-p	Rf	2N247; 2N522
2N116	p-n-p	Af	2N175 GT81
2N128	s-b	Rf	2N346/SB103; 2N604
2N129	s-b	Rf	2N128; 2N344/SB101; 2N345/SB102; 2N603
2N130	p-n-p	Af	2N44; 2N63; 2N76; 2N107; 2N190; 2N359; 2N360; 2N361

Number	Type	Function	Closest Replacement
2N130 (continued)			CK722 GT14 WTV-30V-LG; WTV-B5
2N131	p-n-p	Af	2N36; 2N79; 2N104; 2N191; 2N206; 2N215; 2N238; 2N359; 2N360; 2N361 CK722 GT20 WTV-B5; WTV-B5A
2N132	p-n-p	Af	2N65; 2N192; 2N265; 2N362; 2N363 CK725 GT81 WTV-AT6; WTV-AT6A
2N133	p-n-p	Af	2N359; 2N360; 2N361 CK727 GT74 WTV-B5; WTV-B5A
2N135	p-n-p	If	2N111; 2N111A; 2N123; 2N409; 2N410; 2N482; 2N483; 2N520 WTV-BA6; WTV-BA6A
2N136	p-n-p	Rf	2N112; 2N112A; 2N113; 2N137; 2N409; 2N410; 2N482; 2N483; 2N520 WTV-BE6; WTV-BE6A
2N137	p-n-p	Rf	2N113; 2N114; 2N521 WTV-BE6; WTV-BE6A
2N138	p-n-p	Af	2N109; 2N270; 2N321; 2N359; 2N360; 2N361 WTV-B5; WTV-B5A
2N138A	p-n-p	Af	2N186; 2N186A; 2N249; 2N319; 2N362; 2N363 WTV-AT6; WTV-AT6A

Number	Type	Function	Closest Replacement
2N139	p-n-p	If	2N135; 2N136; 2N218; 2N482; 2N483 GT760R WTV-BA6; WTV-BA6A
2N140	p-n-p	Conv	2N136; 2N137; 2N219; 2N485; 2N486 GT761R WTV-BE6; WTV-BE6A
2N141	p-n-p	Power	2N68; 2N101; 2N143
2N142	n-p-n	Power	2N95; 2N102; 2N144
2N143	p-n-p	Power	2N68; 2N101; 2N141
2N144	n-p-n	Power	2N95; 2N102; 2N142
2N145	n-p-n	If	2N146; 2N169; 2N292 GT948R
2N146	n-p-n	If	2N145; 2N169; 2N292 GT948R
2N147	n-p-n	Osc	2N164A; 2N168A; 2N293 GT948R
2N148	n-p-n	If	2N148A; 2N169; 2N292 GT948R
2N148A	n-p-n	If	2N148; 2N169; 2N292
2N149	n-p-n	If	2N149A; 2N169A; 2N293
2N149A	n-p-n	If	2N149; 2N169A; 2N293
2N150	n-p-n	If	2N150A; 2N169A; 2N293 GT948R
2N150A	n-p-n	If	2N150; 2N169A; 2N293
2N155	p-n-p	Power	2N156; 2N256 WTV-Power-A
2N156	p-n-p	Power	2N155; 2N256 WTV-Power-A

Number	Type	Function	Closest Replacement
2N158	p-n-p	Power	2N173
2N164A	n-p-n	Osc	2N147; 2N168A; 2N293 GT792R
2N165	n-p-n	If	2N169; 2N169A GT948R
2N166	n-p-n	Rf	2N170 GT229
2N168	n-p-n	Rf	2N164A; 2N168A; 2N94A; 2N293 GT792R
2N168A	n-p-n	Osc	2N164A; 2N292
2N169	n-p-n	If	2N165; 2N168A; 2N292; 2N293 GT948R
2N169A	n-p-n	If	2N169; 2N292; 2N293
2N170	n-p-n	Rf	2N166 GT948R GT792R
2N172	n-p-n	If	GT792R
2N173	p-n-p	Power	—
2N174	p-n-p	Power	—
2N175	p-n-p	Af	2N77; 2N192; 2N220; 2N237; 2N265; 2N324; 2N359; 2N360; 2N361 GT74 WTV-B5; WTV-B5A
2N176	p-n-p	Power	2N178 WTV-Power-A
2N178	p-n-p	Power	2N176
2N179	p-n-p	Power	—
2N180	p-n-p	Af	2N224; 2N225; 2N181; 2N359; 2N360; 2N361; 2N565 WTV-30V-MG; WTV-B5; WTV-B5A

Number	Type	Function	Closest Replacement
2N181	p-n-p	Af	2N224; 2N225 WTV-30V-MG; WTV-B5; WTV-B5A
2N182	n-p-n	If	2N168; 2N170; 2N211; 2N313; 2N314; 2N445
2N185	p-n-p	Af	2N77; 2N105; 2N159; 2N160; 2N161; 2N175; 2N191; 2N220 GT81 WTV-30V-MG; WTV-B5; WTV-B5A
2N186A	p-n-p	Af	2N186; 2N307
2N187	p-n-p	Af	2N187A; 2N249; 2N319; 2N359; 2N360; 2N361 GT81 WTV-B5; WTV-B5A
2N187A	p-n-p	Af	2N187; 2N249; 2N319; 2N359; 2N360; 2N361 WTV-B5; WTV-B5A
2N188	p-n-p	Af	2N188A; 2N226; 2N227; 2N320; 2N359; 2N360; 2N361 GT109 WTV-B5; WTV-B5A
2N188A	p-n-p	Af	2N188; 2N226; 2N227; 2N320
2N189	p-n-p	Af	2N37; 2N44; 2N63; 2N107; 2N130; 2N322; 2N362; 2N363 GT14 WTV-AT6; WTV-AT6A
2N190	p-n-p	Af	2N34; 2N41; 2N46; 2N47; 2N48; 2N49; 2N322; 2N362; 2N363 GT20 WTV-AT6; WTV-AT6A

Number	Type	Function	Closest Replacement
2N191	p-n-p	Af	2N64; 2N77; 2N79; 2N105; 2N131; 2N185; 2N206; 2N238; 2N323; 2N362; 2N363 GT81 WTV-AT6; WTV-AT6A
2N192	p-n-p	Af	2N65; 2N132; 2N175; 2N220; 2N237; 2N324; 2N362; 2N363 GT81 WTV-AT6; WTV-AT6A
2N193	n-p-n	Osc	2N194; 2N212; 2N216 GT948R
2N194	n-p-n	Osc	2N193; 2N212; 2N216 GT948R
2N206	p-n-p	Af	2N64; 2N77; 2N79; 2N105; 2N131; 2N185; 2N191; 2N238; 2N323; 2N567 WTV-30V-MG
2N207	p-n-p	Af	2N207A; 2N207B; 2N265; GT81 WTV-20V-MG; WTV-30V-MG
2N207A	p-n-p	Af	2N207; 2N207B; 2N265 WTV-20V-MG; WTV-30V-MG
2N207B	p-n-p	Af	2N207; 2N207A; 2N265 WTV-20V-MG; WTV-30V-MG
2N211	n-p-n	Osc	2N94; 2N482; 2N483 GT948R
2N212	n-p-n	Osc	2N193; 2N194; 2N314 GT792R

Number	Type	Function	Closest Replacement
2N213	n-p-n	Af	2N521
2N214	n-p-n	Af	2N288; 2N522
2N215	p-n-p	Af	2N79; 2N104; 2N323; 2N565
2N216	n-p-n	If	2N313; 2N482; 2N483 GT948R
2N217	p-n-p	Af	2N109; 2N359; 2N360; 2N361; 2N362; 2N363 GT109 WTV-B5; WTV-B5A
2N218	p-n-p	If	2N112; 2N112A; 2N113; 2N136; 2N139; 2N482; 2N483; GT760R WTV-BA6; WTV-BA6A
2N219	p-n-p	Osc	2N113; 2N136; 2N140; 2N485; 2N486 6T761R; WTV-BE6
2N220	p-n-p	Af	2N65; 2N132; 2N175; 2N192; 2N237; 2N324 GT74 WTV-AT6; WTV-AT6A
2N223	p-n-p	Af	2N105; 2N191; 2N362; 2N363; GT81
2N224	p-n-p	Af	2N180; 2N181; 2N225; 2N359; 2N360; 2N361 WTV-B5; WTV-B5A
2N225	p-n-p	Af	2N180; 2N181; 2N224; 2N359; 2N360; 2N361 WTV-B5; WTV-B5A
2N226	p-n-p	Af	2N188; 2N188A GT109 WTV-B5; WTV-B5A
2N227	p-n-p	Af	2N188; 2N188A; 2N359; 2N360; 2N361 GT109

Number	Type	Function	Closest Replacement
2N228	n-p-n	Af	2N214
2N229	n-p-n	Af	2N306 GT229
2N238	p-n-p	Af	2N191; 2N215; 2N362; 2N363; GT81 WTV-B5; WTV-B5A
2N241	p-n-p	Af	2N224; 2N225; 2N241A; 2N359; 2N360; 2N361 GT109 WTV-B5; WTV-B5A
2N241A	p-n-p	Af	2N224; 2N225; 2N241
2N242	p-n-p	Power	—
2N247	p-n-p	Rft	2N267; 2N274; 2N606; 2N607
2N255	p-n-p	Power	—
2N256	p-n-p	Power	2N155; 2N156; 2N158
2N267	p-n-p	Rft	2N247; 2N274; 2N606
2N277	p-n-p	Power	2N278
2N278	p-n-p	Power	2N277
2N292	n-p-n	If	2N145; 2N146; 2N148; 2N148A; 2N169; 2N169A; GT948R
2N293	n-p-n	Rf	2N147; 2N149; 2N149A; 2N150; 2N150A; 2N164A; 2N168; 2N169; 2N169A; GT792R
2N301	p-n-p	Power	2N301A; WTV-Power-A
2N301A	p-n-p	Power	2N301; WTV-Power-A
2N313	p-n-p	If	2N182; 2N292; GT948R
2N314	n-p-n	If	2N293; GT792R
CK721	p-n-p	Af	2N36; 2N64; 2N104; 2N131; 2N238

Number	Type	Function	Closest Replacement
CK722	p-n-p	Af	2N63; 2N107; 2N190 TR-722
CK725	p-n-p	Af	2N65; 2N132; 2N192; 2N265; 2N359; 2N360; 2N361 WTV-B5; WTV-B5A
CK759	p-n-p	Osc	2N111; 2N111A; 2N135; 2N482; 2N483
CK760	p-n-p	Rf	2N112; 2N112A; 2N136; 2N409; 2N410; WTV-20mc
CK761	p-n-p	Rf	2N113; 2N137; 2N409; 2N410
CK762	p-n-p	Rf	2N114

* Insufficient data available to make comparison.

† Drift type transistor. Not interchangeable with any type other than drift.



transistor terms

THE following are definitions of terms used in reference to transistors, their theory, operation, manufacture and circuitry. Standard electronic terms, as well as scientific terms that do not pertain directly to transistors, are not included. You may find that several terms may have the same definition, or that one term may have more than one. In either case, all that are of importance are listed. No attempt has been made to include all variations in spelling of some particular words.

Many books on the subject of transistors include abbreviations for various transistor parameters, such as input resistance, output resistance, forward transfer resistance, etc. These have not been included since the primary function of this book is as a servicing aid. Finally, you should keep in mind that the entire subject of semiconductors is growing at an astonishing rate, hence no claim could possibly be made that a listing of transistor terms is complete. The terms defined here are those that the technician will encounter most often in service literature.

A

Acceptor: An impurity metal, such as indium, that is added to the molten semiconductor while the crystal is being grown to produce a p-type semiconductor.

Acceptor impurity: Same as acceptor. An element which has fewer valence electrons than germanium.

Alloy-diffused transistor: Transistor in which the base is diffused in, and the emitter alloyed.

Alloy junction: A junction produced by alloying an impurity metal to the semiconductor; e.g., indium alloyed to an n-type germanium wafer.

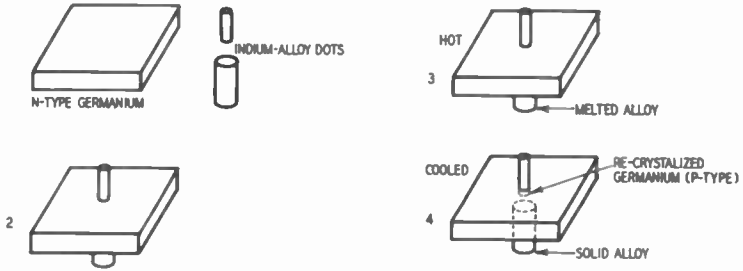

Steps in making an alloy transistor.

Alloy process: A process in which an impurity metal, in the form of a button or dot, is placed upon the face of the semiconductor wafer and heated until it melts. It is then allowed to cool rapidly. The impurity metal alloys itself with the semiconductor wafer to produce a p-n junction.

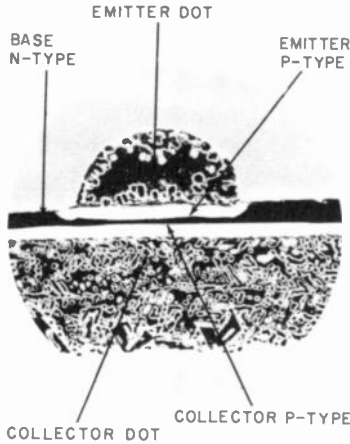

Cross-section photograph of an alloy transistor. Note that the junctions are parallel.

Alloy transistor: Transistor made by the alloy process.

Alpha: The current gain between the emitter and collector electrodes. In a point-contact transistor, alpha may exceed unity, but in a junction transistor it is *always* less than unity.

Alpha-cutoff frequency: The frequency at which the gain of the transistor is .707 times (-3 db) lower than its low-frequency value. The low-frequency value is usually measured at 1,000 cycles.

Amplifier, grounded-base: An amplifier in which the base electrode is common to the emitter and collector electrodes.

Amplifier, grounded-collector: An amplifier in which the collector electrode is common to the base and emitter electrodes.

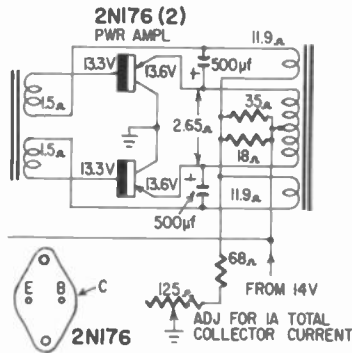

Grounded-collector amplifier.

Amplifier, grounded-emitter: An amplifier in which the emitter electrode is common to the base and collector electrodes.

B

Barrier: A region that separates two different types of semiconductors.

Barrier capacitance: The capacitance that exists in the area near a barrier that is without current carriers under the influence of reverse bias.

Barrier layer: The area near a barrier that is without current carriers under the influence of reverse bias.

Barrier-layer capacitance: See Barrier capacitance.

Base: An electrode of a transistor whose function is similar to the grid in a vacuum tube.

Base bias: The voltage that is applied to the base electrode.

Base-bias network: The resistors external to the transistor that are used to provide the proper base bias to the transistor.

Base current: The current that flows through the base electrode. This current is in the order of microamperes, except in power transistors where the current may be as high as 1 ampere.

Base resistance: The resistance of the base electrode in the T-equivalent of a transistor.

Base ring: The ohmic contact made to the base region of a power transistor. It is in the shape of a ring.

Beta: The current gain between the base and collector electrodes. The value of beta is dependent upon the value of alpha.

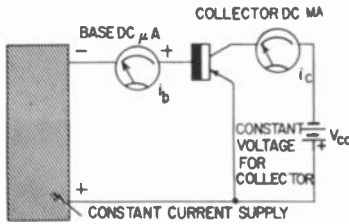

Test circuit for the measurement of beta.

Beta-cutoff frequency: The frequency at which the value of beta is .707 times (-3 db) lower than its low-frequency value.

Boundary, p-n: The boundary, or junction, between the p-type and n-type areas of a semiconductor.

Breakdown voltage: See Zener voltage.

Button: A piece of impurity metal used in alloy transistors to form the emitter or collector electrodes.

C

Carriers: Electrons or holes that carry current through a semiconductor.

Collector: An electrode of a transistor whose function is similar to that of a plate in a vacuum tube.

Collector bias: The voltage applied to the collector electrode.

Collector capacitance: Barrier capacitance that exists in the collector junction.

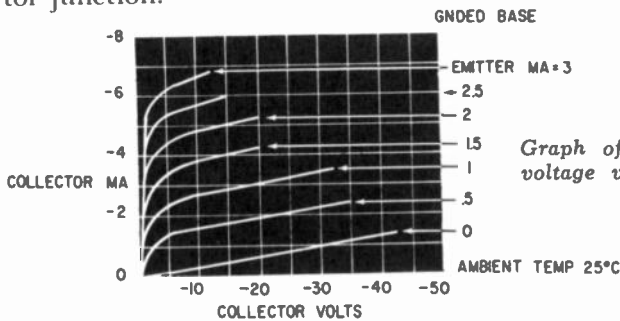

Graph of transistor collector voltage vs. collector current.

Collector characteristic curves: A set of characteristic curves of collector voltage vs. collector current for a fixed value of base current. These curves are similar to the plate curves of certain types of vacuum tubes.

Collector-current runaway: The continuing increase in collector current due to a steady growth of collector junction temperature.

Collector cutoff: No power applied, nor current flowing, in the collector circuit.

Collector-cutoff current: The current that flows through the collector with zero emitter current and normal base-to-collector voltage.

Collector efficiency: The ratio of useful power output (into a load) to the supply power input. It is expressed as a percentage.

Collector family: See Collector characteristic curves.

Collector junction: The junction that exists between the base and collector electrodes.

Collector resistance: The resistance of the collector electrode in the T-equivalent of a transistor.

Common base: See Amplifier, grounded-base.

Common collector: See Amplifier, grounded-collector.

Common emitter: See Amplifier, grounded-emitter.

Complementary symmetry: A circuit that uses an n-p-n and a p-n-p transistor (complementary transistors) in electrical symmetry.

Push-pull amplifier using complementary symmetry.

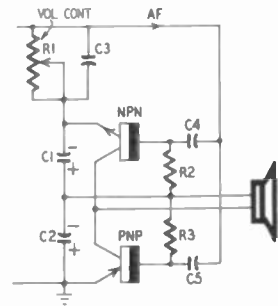

Conductivity: The property of a semiconductor that expresses the ease with which current may flow through it.

Configuration: The description of a transistor amplifier circuit; for example, grounded-emitter configuration.

Coupling: Method of passing the signal from one stage to another; for example, *capacitor coupling*, *transformer coupling*.

Crossover distortion: Harsh type of distortion produced by incorrectly biased class-B amplifiers.

Crystal: The product of the symmetrical arrangement of atoms in a solid.

Crystal lattice: The orderly arrangement of atoms that form a crystal.

Crystalline: Describing the properties of a crystal.

Current amplification: The ratio of output current to input current.

Current carrier: The particle that causes current flow through a semiconductor.

Current gain: See Current amplification.

Cutoff current: Collector current with no emitter current and normal collector-to-base bias.

Czochralski technique: Method of growing large single crystals by pulling them from a molten state; usually used to grow germanium and silicon single crystals.

D

Depletion layer: See Barrier layer.

Depletion-layer capacitance: See Barrier capacitance.

Depletion-layer transistor: Any of several types of transistors which rely directly on the motion of carriers through depletion layers for their operation; for example, the spacistor.

Derating: Reducing ratings on a transistor, especially the maximum power dissipation rating at higher temperatures.

Diamond lattice: The crystal structure of both germanium and silicon as well as diamond.

Diffused-base transistor: Any of several types of drift transistors in which the base is diffused in.

Diffused emitter-collector transistor, diffused E-C transistor: Transistor in which both the emitter and collector are made by the diffusion process.

Diffused junction: A junction in which the p- or n-layer is diffused into the semiconductor wafer.

Diffused-junction transistor: A transistor in which the emitter and collector electrodes have been formed by the diffusion of an impurity metal into the semiconductor wafer.

Diffusion: The movement of current carriers from one region to another. The movement of electrons from n-type to p-type semiconductor or the movement of holes from a p-type to an n-type semiconductor. This diffusion is without voltage applied.

Diffusion process: The method of forming a p-n junction by diffusing an impurity metal into a semiconductor at a high temperature.

Diode: A p-n semiconductor that has the ability to rectify ac.

Dissipation: The loss due to the changing of electrical energy into heat.

Donor: An impurity metal that is added to the molten semiconductor while the crystal is being grown to produce an n-type semiconductor.

Doping: The adding of impurities into the melt to form either p-type or n-type semiconductors.

Dot: See Button.

Double-base diode: See Unijunction transistor.

Double-base junction transistor: A transistor with two separate base connections. Also called a tetrode transistor.

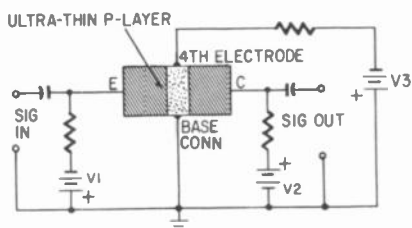

Double-base junction transistor.

Drain: An electrode on a field-effect type transistor.

Drift: The motion of current carriers in the semiconductor because of applied voltage.

Normal construction of a drift transistor. A fourth lead is often added to provide shielding.

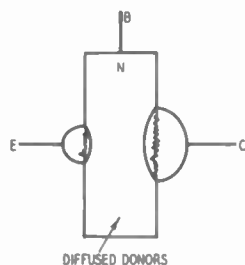

Drift transistor: A transistor that depends upon and utilizes the drift to carry current to the electrodes.

E

Electroforming: A method of producing a p-n junction by passing an instantaneously large current through a semiconductor. This method is used with point-contact diodes and transistors only.

Electrons: Negatively charged current carriers.

Emitter: An electrode of a transistor whose function is similar to that of the cathode in a vacuum tube.

Emitter bias: The voltage applied to the emitter electrode.

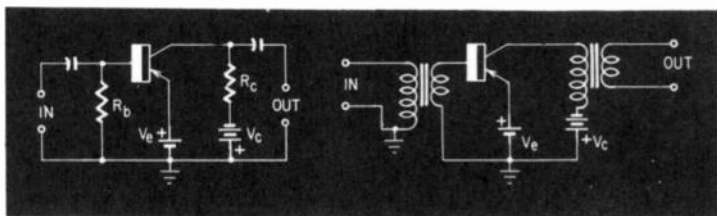

Emitter bias is positive for a p-n-p and negative for an n-p-n transistor.

Emitter junction: The junction that exists between the base and emitter electrodes.

Emitter follower: A grounded-collector amplifier whose operation is similar to the vacuum-tube type cathode follower.

Emitter resistance: The resistance of the emitter electrode in the T-equivalent of a transistor.

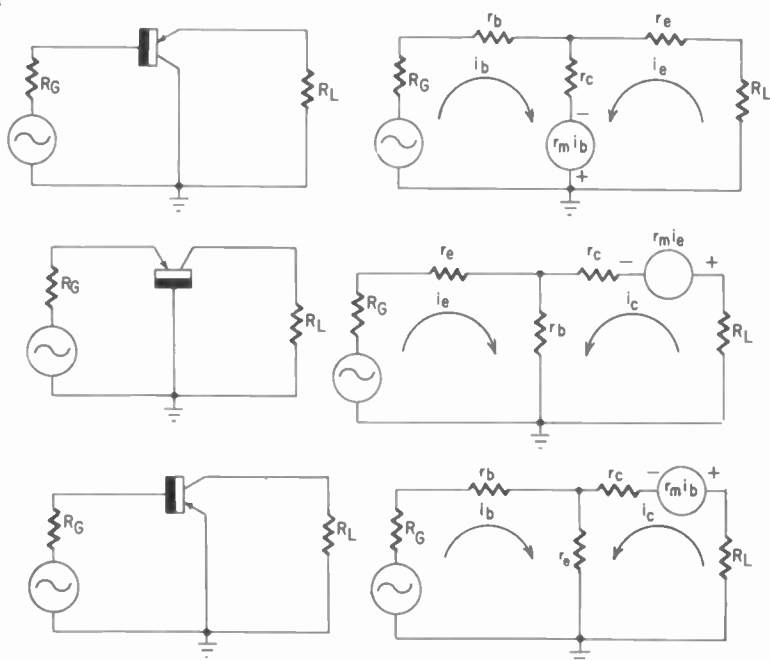

Equivalent circuits of grounded-collector, grounded-base and grounded-emitter arrangements.

Equivalent circuit: A circuit that approximates the transistor under certain conditions.

F

Feedback capacitance: The capacitance present within a transistor that causes a portion of the output signal to be fed back to the input.

Feedback resistance: The resistance present within a transistor that causes a portion of the output signal to be fed back to the input.

Field-effect transistor: A transistor that depends upon the movement of the barrier layer to vary the conductivity between two electrodes, the source and the drain.

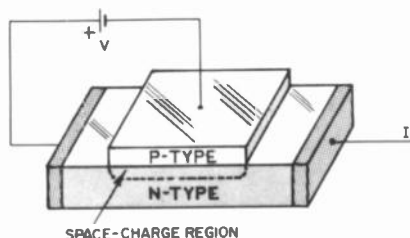

A field-effect transistor.

Floating junction: A junction through which no external current flows. A junction through which no net current flows, e. g., an intrinsic-region transistor.

Forward bias: Application of voltage to a p-n junction that causes a large current flow. Opposite of reverse bias.

Frequency cutoff: The frequency at which the current gain of the transistor drops to a point .707 times (-3 db) below the low-frequency value. See Alpha-cutoff frequency; Beta-cutoff frequency.

Fused-junction: See Alloy-junction

G

g-parameter: Parameter of a transistor relating to conductance.

Gain, current: See Current amplification.

Gate: An electrode of the field-effect transistor.

Germanium: A semiconductor material used for making transistors and semiconductor diodes. The 32d element in the Periodic Table of chemical elements.

Grounded base: See Amplifier, grounded-base.

Grounded collector: See Amplifier, grounded-collector.

Grounded emitter: See Amplifier, grounded-emitter.

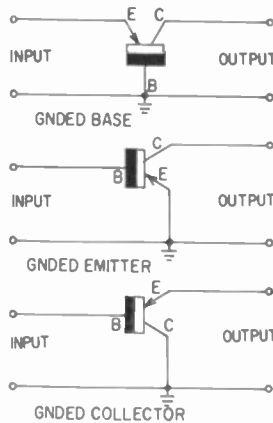

Fundamental grounded-base, grounded-emitter and grounded-collector circuits.

Grown-diffused transistor: A transistor with junctions that are formed by the diffusion of impurity metals near a grown junction.

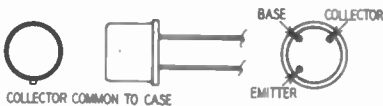

Grown-junction silicon transistor.

Grown-junction transistor: A transistor in which the junctions are formed by the addition of impurity metals to the melt while the crystal is being grown.

H

h-parameters: Hybrid parameters. Parameters that combine the conductance (g) and resistive (r) parameters.

Hall effect: The transverse voltage produced by a current that is traveling at right angles to a magnetic field. This effect is especially prominent in transistors.

Header: The mechanical part of a transistor through which the external leads are passed.

Heat sink: A piece of metal, usually aluminum, used to dissipate rapidly the heat generated by a transistor.

High-frequency parameters: The parameters that are significant at high-frequencies; for example, collector capacitance, transit time, etc.

Hole: A positively charged current carrier in a semiconductor; the space that remains after an electron has been removed; the space normally occupied by an electron.

Hole mobility: The ability of a hole to travel through a semiconductor; the velocity of a hole.

Hook transistor: A transistor with four layers (p-n-p-n). A transistor with a p-type layer sandwiched between an n-type base and an n-type collector. This arrangement provides for higher emitter-input current gains and provides additional amplification for the collector.

h-pi parameters: Parameters used to describe the operation of a transistor in the pi equivalent circuit.

Hybrid parameters: See h-parameters.

Hybrid-pi parameters: See h-pi parameters.

I

i-type: An intrinsic semiconductor.

Impurity: A metallic chemical element added in minute quantities to the semiconductor melt to produce grown p-n junctions, or diffused into a p-type or n-type semiconductor to form a p-n junction. See Donor; Acceptor.

P-n junction using a pellet of acceptor impurity.

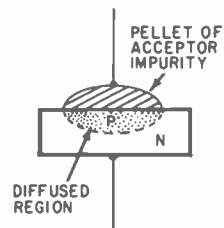

Impurity metal: See Impurity.

Intrinsic-junction transistor: A four-layer transistor (p-n-i-p) with an intrinsic semiconductor layer between the base and collector.

Intrinsic semiconductor: A semiconductor that contains an equal number of holes and electrons. A semiconductor that is neither n-type nor p-type.

i-type: Intrinsic semiconductor.

J

Junction: The area that separates two types of semiconductor; for example, a p-n junction.

Junction diode: A diode that uses a junction to rectify ac. See Diode.

Junction transistor: A transistor that has two junctions, with the base electrode sandwiched between them. The most common type of transistor.

L

Large-signal analysis: Consideration of large excursions from the no-signal bias, so that the nonlinear, switching properties of the transistor are important.

Leakage current: That part of cutoff current due to surface effects.

M

MADT: Micro-alloy diffused-base transistor.

Majority carriers: Whichever type is more plentiful, i.e. electrons in n-type and holes in p-type.

Matched amplifier: A transistor amplifier in which the input and output circuits are matched to the input and output electrodes of the transistor.

Matched gain: The maximum gain obtainable when the input and output impedances of the transistor and circuits are matched.

Matched input: A transistor amplifier in which the input circuit impedance and the transistor input resistance, or impedance, are matched.

Matched output: A transistor in which the output circuit impedance and the transistor output resistance, or impedance, are matched.

Majority carriers: Electrons in an n-type semiconductor; holes in a p-type semiconductor.

Meltback process: A process used to form p-n junctions by melting a properly doped semiconductor and allowing it to resolidify.

Meltback transistor: A transistor made by the meltback process.

Melt-quench transistor: A junction transistor made by quickly cooling a melted-back region.

Micro-alloy transistor: A transistor in which the emitter and collector electrodes are formed by alloying a very thin film of the im-

purity metal to the semiconductor wafer. Similar in construction to the surface-barrier transistor.

Minority carriers: Holes in an n-type semiconductor; electrons in a p-type semiconductor.

Modulator: An electrode on a spacistor.

Monocrystal: A single crystal.

Monocrystalline: Consisting of a single crystal.

N

n-type: A semiconductor doped with a donor impurity metal.

n-p-i-n transistor: A transistor (n-p-n type) with a region of i-type semiconductor sandwiched between the base and collector electrodes.

n-p-n transistor: A junction transistor with n-type collector and emitter electrodes and p-type base electrode.

N-P-N transistor. A positive voltage is put on the collector, a negative voltage on the emitter.

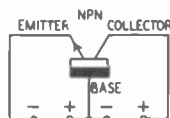

n-p-n-p transistor: A hook type transistor. See hook transistor.

Noise figure: The ratio of actual equivalent noise input to thermal noise input, expressed in decibels.

O

Ohmic contact: The contact between a wire lead and a semiconductor wafer. Not a junction.

P

Parameters: A set of numbers that characterize an electronic device such as a transistor.

Peak inverse voltage: The maximum reverse voltage that can be applied to a semiconductor diode or transistor before breakdown occurs.

Photodiode: A semiconductor diode in which the reverse current increases with illumination.

Photoresistor: A semiconductor resistor whose resistance decreases with illumination.

Phototransistor: A semiconductor resistor whose resistance decreases with illumination.

Pinchoff: The equivalent of collector cutoff. The effect of reduc-

ing to an absolute minimum the source-to-drain current in a field-effect transistor.

Pinchoff voltage: The voltage at which pinchoff occurs.

p-n junction: A junction consisting of p-type and n-type semiconductors.

p-n-i-p transistor: A transistor (p-n-p type) with a region of i-type semiconductor sandwiched between the base and collector.

p-n-p transistor: A junction transistor with p-type collector and emitter electrodes and n-type base electrode.

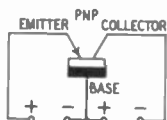

P-N-P transistor. A negative voltage is put on the collector, a positive voltage on the emitter.

p-n-p-n transistor: A hook type transistor.

Point contact: A catwhisker placed on a semiconductor wafer.

Point-contact diode: A semiconductor diode that makes use of a point contact. See Diode.

Point-contact transistor: A transistor that makes use of point contacts for the emitter and collector electrodes. The p-n regions are formed by the electroforming process.

Polycrystalline: Consisting of many crystals.

Power gain: The ratio of output power to signal input power.

Power transistor: An alloy-junction transistor designed to handle

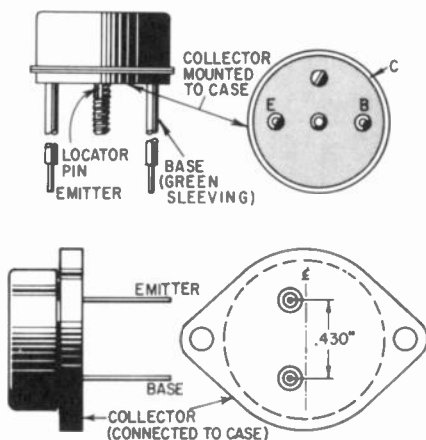

Alloy-junction germanium p-n-p power transistors intended for use in class-A audio power output stages, particularly in automobile radio receivers.

high currents and power. Primarily used in audio and switching circuits.

p-type: A semiconductor doped with an acceptor impurity metal.

R

r-parameters: Parameters of a transistor relating to resistivity.

Rate-grown transistor: A transistor in which the p-n junctions are formed by varying the rate of growth of the semiconductor crystal.

Recombination: The combining of a hole and electron.

Rectifier: Any device which has a nonsymmetrical volt-ampere curve, and which therefore can be used to rectify a.c.; for example, *junction diode*.

Resistivity: The ability of a semiconductor to oppose the flow of current through it. The reciprocal of conductivity.

Reverse bias: Application of a voltage that causes little or no current flow. The opposite of forward bias.

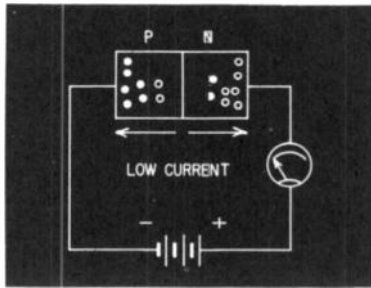

Reverse bias produces little current flow!

Reverse current: The current that flows when reverse bias is used.

S

Saturation: The low-resistance condition in a transistor at low collector voltage.

Saturation current: That portion of cutoff current not due to surface effects; do not confuse with *saturation*.

Saturation resistance: The ratio of voltage to current in saturation.

Seed: A small monocrystal of semiconductor material used to start the growth of a large monocrystal from which the semiconductor wafers are cut.

Selenium: A semiconductor material used for making semiconductor diodes. The 34th element in the Periodic Table of chemical elements.

Semiconductor: A material that is neither a good conductor nor a good insulator. A solid that exhibits properties of both insulators and conductors. A material that conducts current by means of holes and electrons.

Silicon: A semiconductor material used for making both transistors and semiconductor diodes. The 14th element in the Periodic Table of chemical elements.

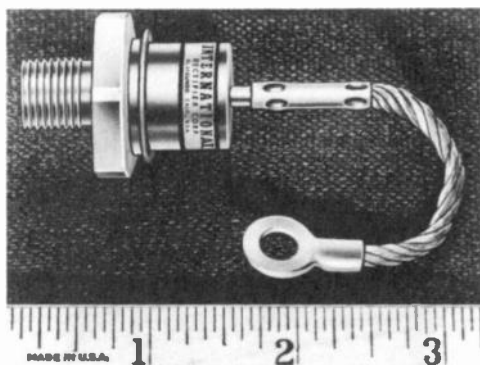

Silicon power diode.

Source: An electrode on a field-effect transistor.

Space-charge layer: See Barrier layer.

Physical arrangement of the spacistor.

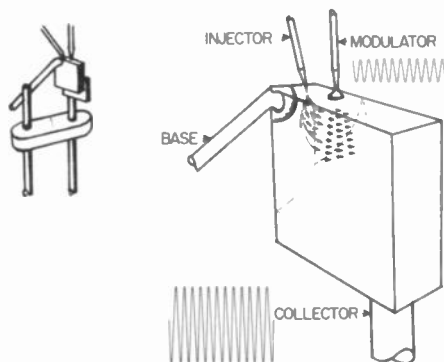

Spacistor: A transistor that relies upon the modulation of carriers injected into a barrier layer.

Stability: The ability of a transistor amplifier circuit to remain at or near the dc operating point of the transistor.

Stability factor: The measurement of stability.

Stabilization: The introduction of stability into a transistor amplifier circuit.

Storage effect: The temporary storage of injected excess minority carriers in the higher-resistivity side of the junction.

Surface barrier: A barrier formed at a surface due to the trapped carriers at the surface.

Surface-barrier transistor: A transistor that uses surface barriers instead of junctions.

Appearance of a surface-barrier transistor.

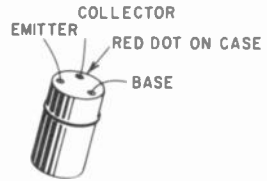

Symmetrical transistor: A junction transistor in which the emitter and collector electrodes are interchangeable.

T

T-equivalent: The equivalent circuit of a transistor at dc levels containing the resistances of all electrodes and connected in the form of a T.

T-parameters: Parameters that pertain to transistors.

Tandem transistor: A transistor that consists of two transistors connected in series internally.

Tetrode transistor: A transistor that has four electrodes.

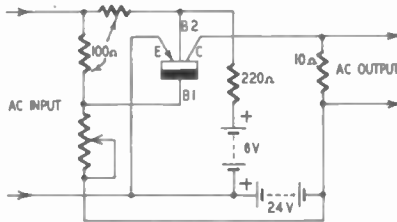

Circuit making use of a tetrode transistor.

Thermal runaway: A continuing increase in collector junction dissipation due to a continuing increase in junction and ambient temperatures.

Thermistor: Temperature-sensitive resistor, usually made from a semiconductor.

Transistor: A semiconductor device with three or more electrodes.

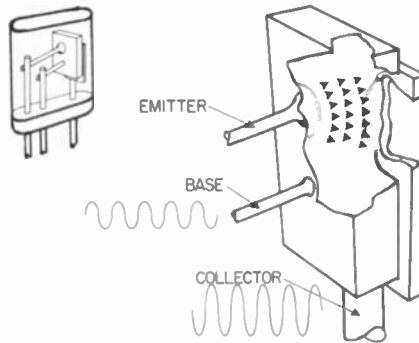

One of the possible arrangements of a transistor.

Transistor action: The mechanisms of amplification in a junction transistor.

Transit time: The elapsed time of diffusion of a minority carrier from the emitter electrode to the collector electrode.

Transition layer: See Barrier layer.

Transition-layer capacitance: See Barrier capacitance.

Transition region: See Barrier layer.

Trap: An imperfection in a semiconductor wafer that prevents the carriers from moving.

Trapping: The prevention of the movement of carriers through a semiconductor.

*The Unijunction transistor:
a-construction; b-schematic symbol;
c-lead connections.*

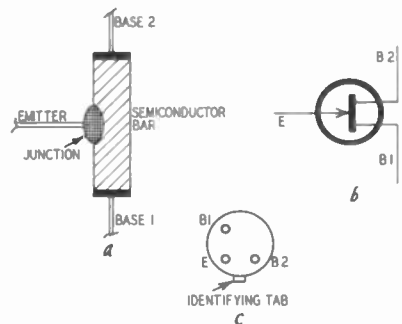

U

Unijunction transistor: A transistor having only one junction, made specifically for switching circuits.

Unilateralization: Neutralization.

Unipolar transistor: A field-effect transistor.

V

Valence bond: The bond formed between the electrons of two or more atoms. The bond between the nucleus of an atom and its orbital electrons.

Vapor diffusion: See Diffusion process.

Varistor: A semiconductor device with a symmetrical but non-linear volt-ampere characteristic.

Voltage amplification: The ratio of output voltage to input voltage.

Voltage gain: See Voltage amplification.

W

Whisker: A point contact.

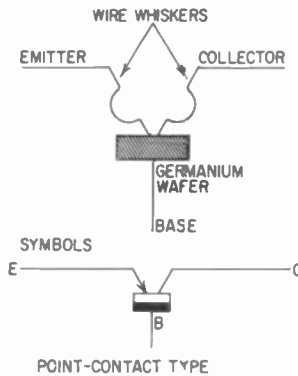

The point contact transistor uses a pair of wire whiskers. The symbol is shown below.

Z

Zener breakdown: The breakdown of a semiconductor.

Zener diode: A diode used as a voltage regulator or reference.

Zener voltage: The reverse voltage at which a large current starts to flow through the semiconductor. This is caused by Zener breakdown.

Zone refining: A process used to produce a semiconductor of high purity. The semiconductor crystal is placed in a crucible and the whole is passed through zones of intense heat. The crystal melts a portion at a time, with the previously melted portion solidifying before the next portion can solidify. This causes the impurities to follow the molten portion and congregate at one end of the crystal. This end is then cut off the crystal and what remains is of a very high purity.

A	
Ac Operated Bench Supply	139
Ac Vacuum-Tube Voltmeter	76
Acceptor	199
Acceptor Impurity	14, 199
Action of Transistor Detector	61
Adjusting Spark Plug Gap	134
Af Signal Generator	72
Asc:	
Amplifier	63
Circuits, Special	62
Detector	63
Filter Capacitor	105
If Amplifier	55, 59
Rf Amplifier	49
Transistor Detector	62
Aligning the Converter	118
Alignment, If	117
Alignment, Receiver	117
All-Wave Radios	163
Alloy-Diffused Transistor	199
Alloy Junction	200
Alloy Process	200
Alloy Transistor	200
Alloy-Junction Transistors	25
Alpha	33, 200
Alpha-Beta Conversion Chart	176, 177
Alpha Cutoff Frequency	39, 44, 174, 201
Alpha, Measuring	169
Amateur Band Converter	159, 160
Amplification, Current	32, 204
Amplifier:	
Audio	64
Grounded-Base	201
Grounded-Collector	30, 201
Grounded-Emitter	30, 201
If	54
Matched	210
Reflex	60
Rf	44
Simple Transistor	23
Antenna:	
Input Circuit	123
Matching	124
Trimmer	118
Audio:	
Amplifier	64
Driver Stage, Checking the	112
Output, Low	116
Output Stage, Class-A,	
Checking the	112
Output Stage, Class-B,	
Checking the	113
Power Amplifier, Class-A	64
Power Amplifier, Class-B	64
Auto:	
Electrical System	138
Radio, Installing the	137
Radios	121
Radios, Hybrid	124
Radios, Operating Conditions of	121
Radios, Transistor	123
Automatic Gain Control	62
Automatic Tuning	129
B	
Barrier:	
Capacitance	201
Layer	201
Layer-Capacitance	201
Surface	215
Base:	
Bias Network	201
Current	201
Current Bias, Fixed	35
of Transistor	23
Resistance	201
Ring	202
Basic Construction of a Transistor	22
Battery:	
Life	16
Polarity	138
Storage	126
Bench Supply, Ac-Operated	139
Beta	33, 202
Beta Cutoff Frequency	174, 202
Beta, Measuring	170
Bias:	
Arrangement of Tetrode Transistor	29
Collector	202
Emitter	206
Fixed Base-Current	35
Forward	19, 207
Reverse	213
Stabilization	36
Transistor	31
Biasing, Transistor	33
Bond, Co-valent	11
Boundary, P-N	202
B-Plus, Low Output	144
Breakdown Voltage	202
Breakdown, Zener	217
Broadcast and Short-Wave Preselectors	160
Broken Conductors, Repairing	91
Button	202
Button, Impurity	200
Buzz, Elimination of	128
Bypass Capacitors, Checking	143

C			
Capabilities, Frequency	38	Conductivity	203
Capacitance:		Conductors, Repairing Broken	90
Barrier	201	Configuration	203
Barrier-Layer	201	Configurations, Transistor	28
Collector	202	Constant-Current Power Supply	168
Decade	78	Control:	
Feedback	207	of Current by Base	23
Capacitor:		Regeneration	148
Checker	75	Volume, Placement in Trf	155
Decade	77	Controls, Placement of Tone	66
Suppressor	135	Conversion Chart, Alpha-Beta	176, 177
Carrier, Current	204	Conversion Gain, Transistor	50
Carriers	202	Converter:	
Carriers, Majority	210	Aligning the	118
Carriers, Minority	211	Amateur Band	159, 160
Characteristic Curves, Collector	202	Dc-to-Dc	126
Characteristic Curves, Plate	21	Fm	157
Characteristics, Grounded-Emitter	172	Stage, Checking the	106
Characteristics, Transistor	30	Vacuum-tube Triode	53
Chart, Troubleshooting	114	Converters	156
Checker, Capacitor	75	Coupling	203
Checking:		Coupling, Permeability-Tuned	123
Audio Driver Stage	112	Co-valent Bond	11
Audio Output Stage, Class-A	112	Crossover Distortion	203
Audio Output Stage, Class-B	113	Crystal:	
Bypass Capacitors	143	Lattice	203
Converter Stage	106	Lattice, Atoms in	9
Dc-to-Dc Converter	144	Structure	8
Diode Detector	110	Structure of Germanium	11
First If Amplifier	107	Crystals	7
Local Oscillator	106	Current:	
Mixer Stage	106	Amplification	32, 204
Oscillation	104	Base	201
Reflex Amplifier Stage	109	Carrier	204
Regenerative Receiver	149	Carriers, Electrons as	13
Second If Amplifier Stage	108	Carriers, Holes as	13
Transistor Detector	111	Collector-Cutoff	203
Circuit:		Control of by Base	23
Antenna Input	123	Cutoff	204
Diode Detector	61	Feedback	36
Equivalent	207	Flow in Dc-to-Dc Converter	127
Hybrid Auto Radio	125	Flow in P-N Junction	19
Signal-Seeking	13	Reverse	213
Transistor Auto Radio	122	Runaway, Collector	203
Transistor Converter	51, 53	Saturation	213
Circuits:		Stabilizing Resistor	68
Altering	94	Voltage Feedback	37
Printed	85	Curve, Selectivity of a Transistor	46
Transistor	147	Radio	34
Class-A:		Curves, Collector	202
Audio Power Amplifier	64	Curves, Collector Characteristic	202
Driver Amplifier	65	Cutoff:	
Power Output Amplifier	66, 67	Collector	203
Class-B:		Collector Current	173
Audio Power Amplifier	64	Current	204
Push-Pull Amplifier	65	Current, Collector	203
Push-Pull Audio Power Amplifier	64	Frequency	207
Coaxial Transistor	27	Czochralski Technique	204
Coefficient, Temperature	116		
Collector:			
Bias	202	D	
Capacitance	202	Dc-to-Dc:	
Characteristic Curves	202	Converter	126
Current Cutoff	173	Converter, Checking the	144
Current Runaway	203	Converter, Current Flow in	127
Curves	34	Converter, Idling Current	129
Curves, Transistor	24	Dc Voltmeter, Vacuum-Tube	76
Cutoff	203	Decade:	
Cutoff Current	203	Capacitance	77
Efficiency	203	Capacitor	77
Junction	203	Resistance	77, 79
Resistance	203	Defective Transistor, Condition of	100
Common-Emitter Amplifier, Collector	57	Depletion-Layer Transistor	204
Neutralization	30	Derating	204
Comparison of Transistor Circuits	203	Detector:	
Complementary Symmetry	152	Agc	63
Complex Trf Tuner	71, 82	Circuit, Diode	61
Component Substitution	47	Diode	44, 160
Components:		Transistor	61, 111
Feedback Within Transistor	88	Diamond Lattice	204
Mounting	89	Diffused:	
Removing	87, 88, 90	Base Transistor	204
Replacing		Emitter-Collector Transistor	204
		Junction	18, 204

Junction Transistor	25
Diffusion	204
Diode:	
Action of P-N Junction	17
Detector	44, 60
Detector, Checking the	110
Detector, Circuit	61
Junction	210
Semiconductor, Static Resistance of	20
Zener	217
Dissipation	205
Dissipation, Junction	37
Distortion	104
Distortion, Causes of	104
Distortion, Crossover	203
Distributor	132
Donor	205
Doping	205
Double-Base Junction Transistor	205
Drain	205
Drift	205
Drift Transistor	205
Driver Amplifier, Class-A	65

E	
Effects of Temperature	39
Efficiency, Collector	203
Efficiency, Transistor	40
Electrical System, Automobile	138
Electroforming	205
Electrons:	
as Current Carriers	13
Injection of	12
Valence	8
Elimination of Buzz	128
Emitter:	
Bias	206
Collector Transistor, Diffused	204
Follower	206
Junction	206
Resistance	206
Equivalent Circuit	207
Etch-Foil Process	86
External Modulator	75

F	
Fading	115
Feedback:	
Capacitance	207
Components within the Transistor	47
Current	36
Current and Voltage	37
Resistance	171, 207
Voltage	36
Field-Effect Transistor	207
Filter Capacitor, Agc	105
First If Amplifier, Checking the	107
Floating Junction	207
Fm Converter	157, 158
Follower, Emitter	206
Forward Bias	19, 207
Frequency:	
Alpha-Cutoff	39, 44, 201
Beta-Cutoff	202
Capabilities	38
Cutoff	207
Response	38
Fuse	129

G	
Gain:	
Control, Rf	156
Matched	210
Power	33, 212
Transistor	32
Gate	207
Generator, Whine	134
Germanium:	
Crystal Structure of	11

Monocrystal	10
N-Type	15
P-Type	15
G-Parameter	207
Grid, Vacuum tube	21
Grounded-Base:	
Amplifier	201
Amplifier, Neutralized	58
If Amplifier, with Agc	59
Transistor Amplifier	28
Grounded-Collector Amplifier	30, 201
Grounded-Emitter Amplifier	30
Grounded-Emitter Characteristics	172
Grown-Diffused Transistor	208
Ground Junction P-N-P-N Transistor	27
Ground-Junction Transistor	208

H	
Hall Effect	208
Header	208
Heat Sink	67, 208
Heat Sink, Mounting to	84
Heterodyning	115
Hi-Fi Tuners	151
High-Frequency Parameters	209
High-Frequency Sensitivity	115
High-Power Class-A Amplifier	67
Hole Flow in P-Type Germanium	16
Hole Mobility	209
Holes and Electrons, Current Flow	14
Holes as Current Carriers	13
Hook Transistor	209
H-Parameters	208
H-PI Parameters	209
Hybrid Auto Radio, Circuit of	125
Hybrid Auto Radios	124

I	
Idling Current, Dc-to-Dc Converter	129
If:	
Alignment	117
Amplifier	54
Amplifier, Agc	55
Amplifier, Agc First Stage,	
Fixed-Gain Second Stage	57
Amplifier, Common-Emitter with	
Collector Neutralization	56
Amplifier, Coupling	54
Amplifier, Neutralization of	55
Amplifier, Reflex	58
Ignition Lead, Shielding the	133
Impurities in Lattice Structure	12
Impurity:	
Acceptor	14, 199
Button	200
Metal	199
Indium	199
Injection of Electrons	12
Ink, Resist	86
Input and Output Resistances,	
Transistor	31
Input:	
Matched	210
Resistance	171
Resistance, Measuring	169
Installation of Noise Suppressor	132
Installing the Auto Radio	137
Instruments, Test	72
Interference and Noise	131
Interference, Reducing	131
Intermittent Operation	115
Intrinsic-Junction Transistor	209
Intrinsic Semiconductor	209
I-Type	209
Inverse Voltage, Peak	211

J	
Junction:	
Alloy	200
Collector	203

Diffused	18, 204	Neutralized Rf Amplifier Gain	48
Diode	210	Noise:	
Dissipation	37	and Interference	131
Emitter	206	Figure	58, 211
Floating	207	Generation, Point of	131
P-N	212	Suppressor, Installation of	132
Point-Contact	18	Notes, Service	139
Transistor	24, 210	N-P-I-N Transistor	211
Transistor, Double-Base	205	N-P-N Transistor	22, 211
Transistors, Rate Grown	25	N-P-N-P Transistor	211
		N-Type Germanium	15
K		O	
Kits, Transistor	162	Ohmic Contact	211
L		Ohmmeter	77
Laminate, Copper-Clad	86	Operating Point of a Transistor,	
Laminate, Paper-Base	86	Determining the	34
Lattice:		Operation, Intermittent	115
Crystal	203	Oscillation, Checking for	104
Diamond	204	Oscillation Suppressor Resistor	133
Structure, Impurities	12	Oscillator, Local	43, 51
Layer, Barrier	201	Oscillator, Transistor	50
L-C Trap	135	Output:	
Local:		Matched	210
Oscillator	51	Resistance	171
Oscillator, Checking the	106	Resistance, Measuring	170
Oscillator, Disabling the	117	P	
Oscillator, Disablement of	116	Paper-Base Laminate	86
Low Audio Output	116	Parameters:	
Low B-Plus Output	144	H	208
Low-Frequency Sensitivity	115	High-Frequency	209
Low-Plate Voltage Tubes	124	H-Pi	209
Low-Value Resistance, Semiconductor		R	213
as a	10	T	215
		Peak-Inverse Voltage	211
M		Permeability-Tuned Coupling	123
Madt	210	Phase Reversal in Grounded-Base	
Majority Carriers	210	Amplifier	29
Matched Amplifier	210	Photodiode	211
Matched Gain	210	Photoresistor	211
Matched Input	210	Phototransistor	211
Matched Output	210	Pinchoff	211
Matching, Antenna	124	Pinchoff Voltage	212
Measurements and Tests	164	Plate Characteristic Curves	21
Measurements, Voltage	71	P-N Boundary	202
Measuring:		P-N Junction	212
Alpha	169	P-N Junction, Current Flow in	19
Alpha-Cutoff Frequency	174	P-N Junction, Diode Action of	17
Beta	170	P-N-I-P Transistor	212
Beta-Cutoff Frequency	174	P-N-P Transistor	22, 212
Input Resistance	169	P-N-P-N Transistor	27, 212
Output Resistance	170	Point Contact	212
Meltback Process	210	Point-Contact Junction	18
Meltback Transistor	210	Point-Contact Transistor	212
Melt-Quench Transistor	210	Points of Noise Generation	131
Metal, Impurity	199	Polarity, Battery	138
Micro-Alloy Transistor	210	Polycrystalline	212
Minority Carriers	211	Power:	
Mixer	49	Gain	33, 212
Mixer Stage, Checking the	106	Solar	162
Mixer, Vacuum-Tube	49	Supplies	126
Mobility, Hole	209	Supply, Constant Current	168
Modification of Trf	156	Supply, Transistor	80, 83
Modulator	211	Transistor	212
Modulator, External	75	Precautions, Servicing	92
Monocrystal	211	Preselectors	161
Monocrystal, Germanium	10	Preselectors, Broadcast and Shortwave	160
Monocrystalline	211	Printed-Circuit Repair	87
Motorboating	115	Printed Circuits	85
Mounting Components	88	Probe, Rf	82
Mounting to Heat Sink	84	Process, Alloy	200
Multiple-State Regenerative Receiver	150	P-Type Germanium	15
		P-Type Germanium, Hole Flow in	16
		Push-Pull Amplifier, Class-B	65
N		Q	
Network, Base-Bias	201	Quick Check	175
Network, Equivalent 3-Terminal	31	Quick Check Techniques	144
Neutralization of If Amplifier	55		
Neutralization of Rf Amplifier	47		
Neutralized Grounded-base Amplifier	58		

R	
Radios:	
All-Wave	163
Automobile	121
Servicing Transistor	99
Transistor Auto	123
Rate-Grown Transistor	213
Receiver Alignment	117
Receiver Test Points	102
Receivers, Regenerative	147
Recombination	213
Rectifier	213
Reducing Interference	131
Reflex:	
Amplifier	60
Amplifier Stage, Checking the	109
Amplifier, Transistor	59
If Amplifier	58
Trf Radio	154
Trf Tuner	153
Tuner	148
Regeneration Control	148
Regeneration Control, Adjustment of	148
Regenerative:	
Receivers	147
Receivers, Checking	149
Receivers, Multiple-Stage	150
Receivers, Servicing	148, 149
Short-Wave	150
Relay, Tuner	130
Removing Components	89
Repair, Printed-Circuit	87
Repairing Broken Conductors	91
Replacing Components	81, 190
Requirements, Transistor Power	40
Resist Ink	86
Resistance:	
Base	201
Collector	203
Decade	77, 79
Emitter	206
Feedback	171, 207
Input	171
Output	171
Saturation	213
Static, of Semiconductor Diode	20
Transfer	171
Resistivity	213
Resistor, Current Stabilizing	67, 68
Response, Frequency	38
Reverse Bias	213
Reverse Current	213
Rf:	
Amplifier	44
Amplifier, Agc	49
Amplifier, Neutralization of	47
Gain Control	156
Probe	82
Signal Generator	75
Ring, Base	202
R-Parameters	213
Runaway, Collector Current	203
Runaway, Thermal	67
S	
Salvaging Transistors	96, 97
Saturation	213
Saturation Current	213
Saturation Resistance	213
Search Tuner	129
Second If Amplifier Stage,	
Checking the	108
Seed	213
Selectivity of Trf	153
Selenium	214
Self Base Current Bias	34
Semiconductor:	
a Low-Value Resistance	10
Intrinsic	209
Theory	7
Sensitivity of Trf	153

Service Notes	139
Servicing:	
Techniques	71, 142
the FM Converter	158
the Regenerative Receiver	148
Transistor Radios	99
Trf Reflex Receivers	154, 155
Shielding Ignition Leads	133
Short-Wave Regenerative Receiver	150
Short-Wave Regenerative Receiver,	
Servicing the	150
Signal:	
Generator, Af	72
Seeking Circuit	130
Tracer	77, 81
Tracing	72
Silicon	214
Sink, Heat	67, 208
Solar Power	162
Soldering Iron, Size of	93
Source	214
Spacistor	214
Spark Plug Gap, Adjusting the	134
Sparkling	131
Speaker, Substitute	77, 80
Special Agc Circuits	62
Springs, Static-Collector	136
Stability	215
Stability Factor	215
Stabilization	215
Stabilization, Bias	36
Static	136
Static-Collector Springs	136
Storage Battery	126
Storage Effect	215
Substitute Speaker	77, 80
Substitution, Component	71, 82
Supplies, Power	126
Suppressor Capacitor	135
Suppressor Resistor, Oscillation	133
Surface Barrier	215
Surface-Barrier Transistor	26, 215
Symmetrical Transistor	215
Symmetry, Complementary	203
T	
Tandem Transistor	215
Techniques, Quick Check	144
Techniques, Servicing	71, 142
Temperature, Effects of	39
Terms, Transistor	199
Test Instruments	72
Test Points, Receiver	102
Testers, Transistors	175
Testing a Transistor	95
Tests and Measurements	167
Tetrode Transistor	27, 215
Tetrode Transistor, Bias Arrangement	29
Tetrode Transistor, Construction of	28
Thermal Runaway	215
Thermistor	140, 216
Thermistor, Use of	68
Tone Controls, Placement of	66
T-Parameters	215
Tracer, Signal	77, 81
Tracing, Signal	72
Transfer Resistance	171
Transistor:	
Alloy	200
Alloy-Diffused	199
Amplifier, Simple	23
Auto Radio Circuit	122, 141
Auto Radios	123
Base of	23
Basic Construction of	22
Bias	31
Biasing	33
Characteristics	30
Circuits	147
Circuits, Comparison of	30
Coaxial	27

Be Sure to Read These Other GERNSBACK LIBRARY Books

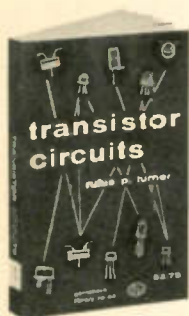

TRANSISTOR CIRCUITS by Rufus P. Turner. Collection of practical circuits by transistor expert Turner includes scores of amplifier, oscillator, power supply, trigger and test equipment schematics, each one tested and debugged. G/L No. 63. 160 pages. **\$2.75**

TRANSISTOR TECHNIQUES. An entirely new low-cost handbook on practical transistor applications. Math and theory kept to a minimum while giving many hints on use of transistors. Includes testing, performance, construction and measurements. G/L No. 61. 96 pages. **\$1.50**

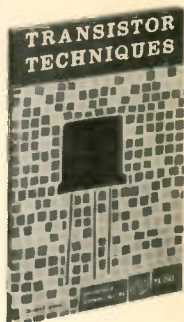

BASIC RADIO COURSE by John T. Frye. Easy-reading theory for the practical man. Uses pleasant conversational style to teach you everything from Ohm's law to circuit analysis, inductance, capacitance, resonance, etc. G/L No. 44. 176 pages. Hard cloth cover. **\$2.25**

TV AND RADIO TUBE TROUBLES by Sol Heller. Faulty tubes cause 90% of all TV and radio failures. This new kind of servicing book shows how to pinpoint and correct the most difficult tube troubles using symptom analysis method. G/L No. 68. 224 pages. **\$2.90**

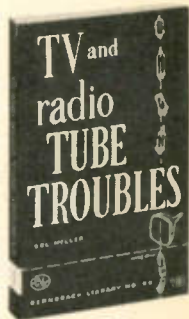

SERVICING RECORD CHANGERS by Harry Mileaf. Make money servicing record changers! Intricate changer mechanisms made easily understandable. Detailed drawings show how to make repairs. An excellent reference book for technicians. G/L No. 59. 224 pages. **\$2.90**

RAPID TV REPAIR by G. Warren Heath. Slash troubleshooting time and earn bigger profits with the most practical TV servicing manual ever written. Common and uncommon troubles alphabetically listed and cross-referenced. G/L No. 60. 224 pages. **\$2.90**



Boost your servicing income with the many shortcuts and techniques in these and other Gernsback Library books. Increase your understanding and enjoyment of high fidelity, build your own electronic projects, use the latest circuits. Learn every phase of electronics! Read about transistor innovations, electronic puzzles, hobbyists' designs, tape recorders and latest servicing data—all in Gernsback Library books.