

1959

Popular Electronics'

# ELECTRONIC EXPERIMENTER'S HANDBOOK

Build / A Satellite  
Listening Post

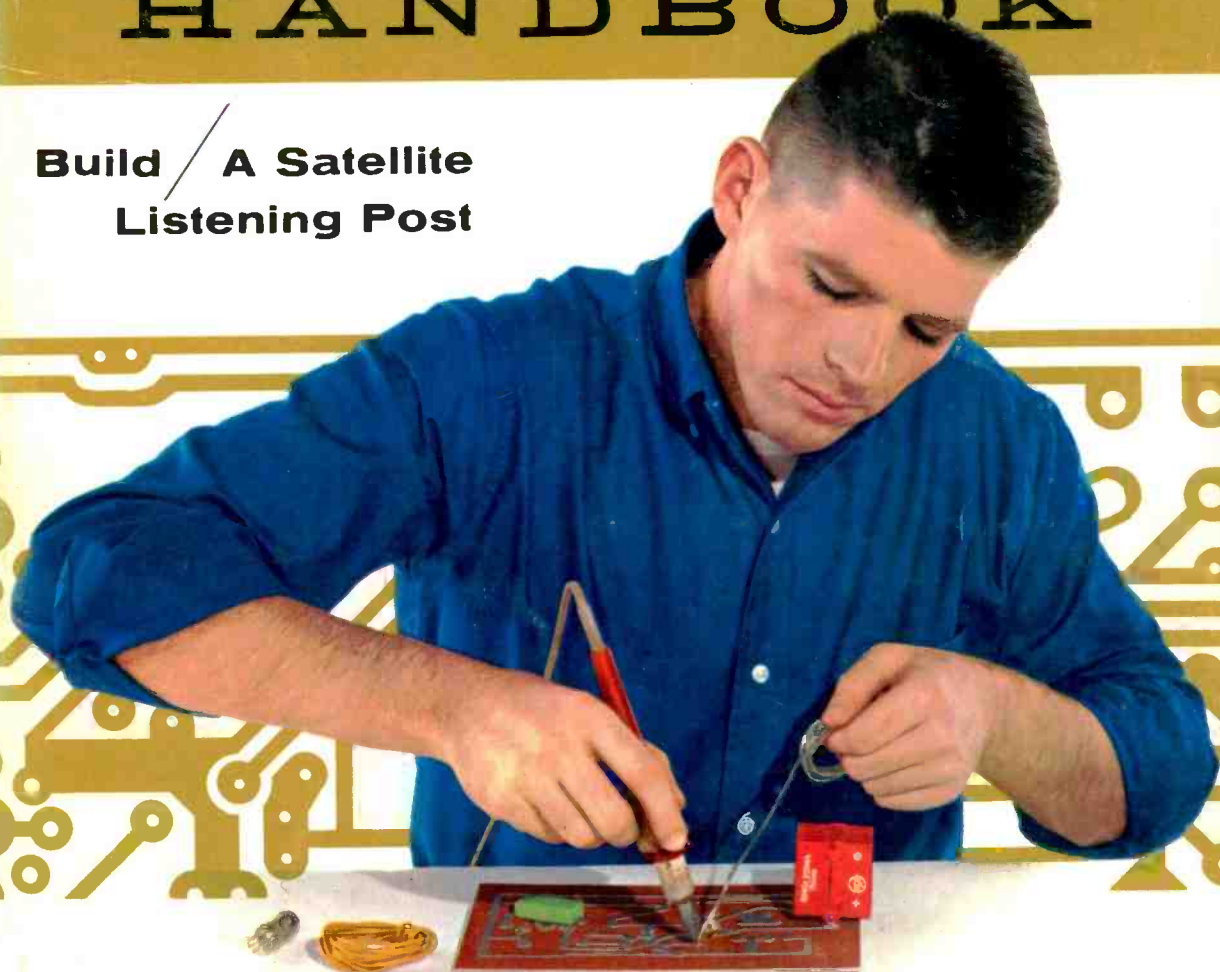

Build . . . Electronic Games • Receivers • and Instruments

48 Projects for / Home & Shop • HiFi System •

Transistorized Photoflash • T



\$ 1.00

(\$1.25 in Canada and elsewhere)

*Enjoy!  
Thanks!  
Jim*

# HOW TO GET A GOOD PAYING JOB IN RADIO-TELEVISION

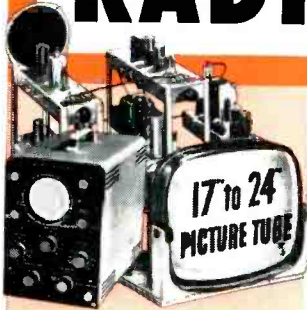

Build this equipment while learning... it's yours to keep!

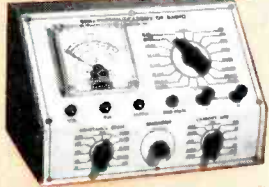
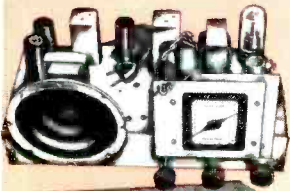

EARN WHILE YOU LEARN AT HOME IN SPARE TIME

I'll prove to you that I can prepare you to become a trained Radio and Television Serviceman in a few months' time... ready to step into a good paying job with a real future! Mail coupon-postcard NOW!



MASON R. WARNER, President

**Only \$6 starts you** "Learn by Doing" Training Plan

Men by the thousands... trained Radio-Television Service Technicians... are needed at once! Perhaps you've thought about entering this interesting, top paying field, but lack of ready money held you back. Now—just \$6 enrolls you for America's finest, most up-to-date home study training in Radio-Television! This offer is made because Radio-Television must have the additional men it needs as quickly as possible. We are willing to do our part by making Sprayberry Training available for less money down and on easier terms than ever before. This is your big opportunity to get the training you need... to step into a fine job or your own Radio-Television Service Business.

**Get Practical Experience with 25 Kits of Radio-TV Parts**

In addition to modern lessons, you train with actual parts and equipment. Build the famous Sprayberry Training Television Set, Multi-Range Tester, 2-Band Radio, other Test Equipment—all yours to keep. Get latest training on Color TV, Transistors, Hi-Fi and UHF Conversions to make your training more valuable.

**Radio-TV Needs You Now! Get all the facts... FREE!**

Radio-Television needs you! See how and why Sprayberry Radio-Television home training offers you more. Three training plans to suit your exact needs. Low payment... only \$6 starts you. Backed by over 27 years of distinguished training experience. Rush special postcard—reply coupon for catalog and free sample lesson.

The Radio-Television industry is begging for trained men for interesting, profitable service work... get set now!

WRITE NAME AND ADDRESS — Cut out card and mail.

YOUR NAME \_\_\_\_\_

ADDRESS \_\_\_\_\_

TOWN \_\_\_\_\_ STATE \_\_\_\_\_



**BUSINESS REPLY MAIL**  
First Class Permit No. 34316, Chicago, Ill.

**SPRAYBERRY ACADEMY OF RADIO-TELEVISION**

Dept. 117-A

1512 Jarvis, Chicago 26, Ill.

**FREE**

new 60 page catalog and actual sample lesson



This coupon needs no stamp or envelope. Just write name in upper left corner, cut out along dotted line and drop in any mail box. Pay no attention to printing on back of the card. By return mail you'll receive our big 60 page catalog and free sample lesson.

**SPRAYBERRY**

ACADEMY OF RADIO-TELEVISION

Dept. 117-A  
1512 Jarvis, Chicago 26, Ill.

1959 **ELECTRONIC**  
Popular Electronics **EXPERIMENTER'S**  
**HANDBOOK**

CONTENTS

SECTION I	listen to the satellites.....	9
SECTION II	for your hi fi.....	19
SECTION III	for your home and darkroom.....	41
SECTION IV	receivers you can build.....	85
SECTION V	electronic games to play.....	101
SECTION VI	for your work shop.....	131
SECTION VII	for your ham shack.....	149

**Oliver Read**, Publisher  
**David A. Findlay**, Editor  
**Art Fitzthum**, Art Editor  
**Fred Wetzler**, Assistant Editor  
**Barbara R. Hearst**, Editorial Assistant  
**John A. Ronan, Jr.**, Advertising Director  
**William G. McRoy**, Advertising Manager

*Cover photography by Bruce Pendleton*

*Illustrations by Gabe Keith*

Copyright © 1959 by Ziff-Davis Publishing Co. All Rights Reserved

ZIFF-DAVIS PUBLISHING CO., One Park Ave., New York 16, N.Y.  
William B. Ziff, Chairman of the Board (1946-1953);  
William Ziff, President; W. Bradford Briggs, Executive Vice President;  
Michael Michaelson, Vice President and Circulation Director;  
Hershel B. Sarbin, Secretary; Howard Stoughton, Jr., Treasurer;  
Albert Gruen, Art Director.

## introduction

*The wonderful part of electronic experimenting is that almost everything you build can be useful to your whole family as well as yourself. Flip through the pages of this book and you will see that almost every project has an application that can make life easier or more fun. These projects are not things to build and throw into a corner after a few hours of play. Your pocket FM set will become a constant companion—your friends and children will have hours of fun playing with the equipment you build from the electronic games section.*

*Another advantage of the projects in this book is that they are as foolproof as it is possible to make construction articles. All of these projects have been built by the readers of POPULAR ELECTRONICS magazine and in a sense have been pre-tested for you.*

*The special section on listening to the satellites can give you the pleasure of listening to sounds from outer space, on your own short-wave receiver. This is a good project for the more advanced experimenter, but the less experienced worker should be able to handle it if he follows the instructions to the letter.*

*This book has been designed for pleasure. Not only the pleasure of building, but the pleasure of accomplishment that comes from a worthwhile project.*

The Editors

**LOW COST** introduction to the wonderful world of science!

The **AMERICAN BASIC SCIENCE CLUB** offers this

**EXCITING HOME SCIENCE LABORATORY**  
Fascinating Experiments With



**SOUND** **ELECTRICITY** **HEAT** **ELECTRONICS** **LIGHT** **ATOMIC ENERGY**

**COMPLETE LABORATORY COMES IN 8 KITS . . . ONE A MONTH**  
**SUPPLIES ALL THE EQUIPMENT FOR ALL THE FOLLOWING:**

**ELECTRICAL EXPERIMENTS**

Educational fun with Electro-Magnets, Transformer, Galvanometer, Rheostat, Relay, Voltmeter, Wheatstone Bridge, and other electric equipment.

**RADIO RECEIVER**

A sensitive three tube regenerative radio—transformer powered. Can be plugged into regular 110 a/c home circuit. Complete with head set.

**SPECTROSCOPE**

Fascinating optical instrument used to identify and analyze substances by observing the spectrum of their flame. Spectrum charts included.

**PHOTOELECTRIC EYE**

Photoelectric Tube, Exciter lamp—and Electronic Relay. Everything you need to control motors, bells, alarms, and do other light beam experiments.

**MICROPHONE**

A sensitive carbon microphone that greatly amplifies unsuspected noises. Also adaptable for use with your radio transmitter.

**ELECTRONIC EXPERIMENTS**

Explore functions of vacuum tubes and other electronic components. Build an Electronic Switch—Amplifier, and other experimental circuits.

**CODE PRACTICE SET**

Signal Oscillator, Key and Flasher . . . the complete outfit to learn to receive and transmit the Morse Code . . . the first step to a Ham License.

**STROBE LIGHT**

A variable pulse neon light. "Freezes" motion of rapidly vibrating or rotating objects for close study and checking frequencies, RPM.

**BROADCAST TRANSMITTER**

Sends clear transmissions of both code and voice to nearby radios. Can be used with your microphone, record player, or code oscillator.

**RADIO SERVICE EQUIPMENT**

All the parts to build your own Radio Signal Tracer and a Probe Light Continuity Tester. Both pieces invaluable in radio servicing.

**HEAT EXPERIMENTS**

Laboratory studies of heat and its effect on solids, liquids and gases. Provides two Thermometers, Thermocouple, and Alcohol Burner.

**TELESCOPE**

A mounted astronomical Telescope. High quality ground lens enables you to examine details of the Moon's surface and distant objects.

**SOUND EXPERIMENTS**

Laboratory demonstration of sound waves, resonance and pitch. Equipment includes Loud Speaker, Resonance tube and Sonometer.

**SLIDE PROJECTOR**

Takes 16mm and 35mm slides, sharp focusing, convection cooled. G.E. Projection Lamp included. Also adaptable as a Projection Microscope.

**MICROSCOPE**

High and low power, precision-ground optical lens, self-illuminated. Adaptable for photomicrography in connection with photo lab.

**PHOTOGRAPHY LAB**

Complete dark room equipments Printer—Enlarger—Electronic Timer—Safe Light—Developing Trays and supply of paper and chemicals.

**LIGHT EXPERIMENTS**

A group of interesting experiments with Optical Lenses, Prism, Photometer, Polarized Light, Ultra Violet "Black" Light and Invisible Infra Red.

**WEATHER STATION**

Aneroid Barometer—Humidistat—Sling Psychrometer—Anemometer Rain Gauge—Cloud Charts—Record Charts—Weather Map.

**SPINTHARISCOPE**

Gives you a blown up ringside view of the brilliant explosions of disintegrating radium atoms ejecting alpha particles at 11,000 miles per second.

**ATOMIC RADIATION EXPM.**

Check radioactivity of ores and do radiation experiments with sensitive Electroscopes. Sample of Uranium and other radioactive ore.

**ATOMIC CLOUD CHAMBER**

The famous vapor chamber in which you see various types of illuminated paths made by sub-atomic particles bombarding us from outer space.



Analyzing Glowing Gases with the **SPECTROSCOPE**

Trouble Shooting with the **SIGNAL TRACER**

**PHOTOMICROGRAPH** of a Fly's Wing made with Microscope and Photo Lab (Actual Size 5" diameter)

**SWRI ADMINISTRATION BUILDING**

These Kits are a Real Science Course Developed with World Famous

**SOUTHWEST RESEARCH INSTITUTE**

to bring the fascination of Science to the American Home

The set of eight Instruction Manuals is expertly written, clearly illustrated—easy to understand—exciting and interesting.

**WITHOUT PREVIOUS EXPERIENCE**

You can complete every project and acquire a valuable science background.

**THESE KITS ARE NOT TOYS!**

They consist of standard parts by: **SYLVANIA, MALLORY, G. E., PYRAMID, STACKPOLE, TRIM** AND OTHER RELIABLE MANUFACTURERS  
Retail value of parts alone is over **FIFTY DOLLARS**

**MEMBERS ARE ENTHUSIASTIC!**

I wish I could provide each of my Physics students with all of your enjoyable kits. You are doing a wonderful job.

Allen T. Ayers  
Physics Dept.  
Jamestown High School  
Jamestown, New York

Please accept my congratulations on the thoughtful study that must have gone into the planning of your Science Series.

W. B. Astell, President  
West Virginia Institute of Technology  
Montgomery, W. Virginia

**SAFE!**

Circuits are low voltage supplied by isolation transformer that comes with first kit.

**WEATHER Forecasting**  
Start to a **HAM LICENSE**  
Simplified **RADIO-TV Servicing**

**PHOTOGRAPHY** Darkroom Handbook  
**MICROSCOPE** The World Beyond Your Lens  
**PROSPECTING** for Radioactive Ores

**FREE!** These 6 Auxiliary Textbooks

**ALL THE EQUIPMENT FOR ALL THE ABOVE—only \$29<sup>60</sup>**

SEND **\$2.00** WITH **ONLY** COUPON PAY **\$3.45** ONLY FOR EACH KIT YOU RECEIVE (ONE A MONTH FOR 8 MONTHS)

**FREE** SOLDERING IRON with second Kit

Your Satisfaction or Your Money Back... AND you may cancel at any time without obligation.

These "no risk" assurances because we know you will be...

**SURPRISED! AMAZED! DELIGHTED!**

**MAIL COUPON TODAY**

**AMERICAN BASIC SCIENCE CLUB, Inc., Box 524, San Antonio, Texas**  
Start sending me A.B.S.C.'s "Home Science Lab" in eight kits, one each month. If not satisfied on inspection of first kit I may return it for immediate refund. (I choose plan checked.)  
( ) I enclose \$2.00 and will pay \$3.45 plus COD postage on arrival of each kit. I may cancel unshipped kits at any time.  
( ) I enclose \$29.60 as payment in full, POSTAGE PAID, for all eight kits. I may cancel at any time and get full refund on unshipped kits.

NAME.....  
STREET.....  
CITY..... STATE.....

**AMERICAN BASIC SCIENCE CLUB, Inc. San Antonio, Texas**

# INDEX

building a satellite converter.....	10
the super satelliter antenna.....	18
one tube hi-fi AM tuner.....	20
tuner + audio = radio.....	22
transistorized preamp & control unit.....	24
make your own arm.....	27
hi-fi slave.....	29
switch to stereo.....	32
improving your low-cost phono arm.....	35
slot box your speaker.....	36
make an electronic secretary.....	42
build a conversation piece.....	45
flash lights with transistors.....	48
trap those unwanted stations.....	50
suit your volume with a t-pad.....	54
battery-operated proximity relay.....	56
make the kids happy with a clown.....	59
build the simpla-timer.....	61
transistorized photoflash.....	63
build an electric shutter release.....	69
photographer's light distributor.....	70
transistors replace wall outlet.....	72
how to convert transistor set for car.....	75
squawk with the transihorn.....	78
go mobile with the "auto-fi".....	81
make your own two-set coupler.....	84
pocket FM receiver.....	86
build a half pack.....	88
monoceiver pulls in d-x.....	91
converter for daytime d-x.....	95
conelrad your home.....	98
build the quizzomat.....	102
got the shakes?.....	105
liven up the party with a "warmth meter".....	108
win at nim with debicon.....	110
catch the vanishing ball.....	115
compute with pots.....	119
check your marksmanship with bullets of light.....	122
play games with nixie tubes.....	126
pocket test instruments—voltmeters.....	132
pocket test instruments—audio generator.....	137
pocket test instruments—r-c checker.....	141
build a square wave generator for audio tests.....	146
simple r.f. meter.....	150
check your a.c. calibrator.....	152
semiconductor space spanner.....	154
card file transmitter.....	158

# This book is a Gold Mine Send for it immediately!



**REVEALS HOW YOU CAN GAIN QUICKER SUCCESS  
OR TURN YOUR HOBBY INTO A WELL-PAID CAREER  
IN RADIO . . . TELEVISION . . . ELECTRONICS**

*Whether you're an amateur . . . a hobbyist . . . or already in electronics . . . let us show you how to have a bright career in*

**Electronics — Television — Broadcasting — Guided Missiles — Aeronautical Electronics  
Radar — Automation — Instrumentation — Computers — Industrial Electronics  
Servomechanisms — Astronautics — Communications — Manufacturing — Telemetry**

### TURN YOUR HOBBY INTO A HIGH-PAYING CAREER!

Today thousands of electronics hobbyists have an opportunity to turn their hobbies into profits. It's the "Age of Electronics!" Trained men are in crucial demand! You may be "outside" the electronics industries now, working on a job you enjoy far less than experimenting, building, transmitting, receiving; working for less money than is being paid to electronics engineering technicians. But your "true love" is electronics. Why not awaken to your opportunities—now?

#### **ELECTRONICS HAS GOOD PAYING JOBS FOR TRAINED MEN!**

And only trained men can fill them. You can get your share, if you take time now to gain that indispensable technical knowledge.

Many of the men currently on the street are there for a reason. "As many as 8 out of 10 are deadwood," estimates the chief engineer of a medium-sized Philadelphia firm; the problem is to find the live ones.

—from **ELECTRONICS MAGAZINE**

If you're interested in an honest-to-goodness career in the vigorous young electronics industry, here's how you can step ahead of job-competition, move up to a better job, earn more money, **AND BE SURE OF HOLDING YOUR TECHNICAL JOB, EVEN WHEN THE "DEADWOOD" IS BEING CLEANED OUT.**

Sure you have some experience. But the fellows with only partial technical knowledge move slowly, or stand still while you—the man with advanced technical training—plunge ahead in the golden world of electronics opportunities.

### ACQUIRE NECESSARY TRAINING AT HOME

Use spare-time hobby hours for CREI Home Study as thousands of successful technicians have done since 1927. Get concentrated training in minimum time, then step into a good job and enjoy good pay in the mushrooming electronics industry. CREI courses are being studied *today* on the DEW Line in the Antarctic—in Alamagordo, and in Munich—by electronics experts in guided missile development and by telemetering technicians on the missile ranges.

### CREI TRAINS YOU IN MINIMUM TIME AT HOME

Thousands of men before you have benefited quickly from CREI Home Study training. Thousands of CREI graduates are now employed in industry here and abroad. Here is what they say: "You can quote me as saying that it was the smartest money I ever invested in my life, and it has repaid me several hundred times in earnings, not to mention the confidence and security that accompanied mastery of radio and electronics, thanks to CREI." —Joseph Zelle/W8FAZ; Radio Engineer, WERE, Cleveland, Ohio.

**Brand - New Course Added — Automation and Industrial Electronics Engineering Technology.** Complete course, covers all phases of automation. Special emphasis on theory, functioning, and applications of servomechanisms and computers. Also noteworthy: Lessons on machine control, instrumentation, data-processing, and telemetry.

### CREI OFFERS RESIDENCE TRAINING

at the same high technical level. Day and evening classes start at regular intervals. Qualified residence school graduates earn degree as "Associate in Applied Science." If you have had electronic education, or experience in electronics—and realize the need of a high-level technical knowledge to make good in the better electronic jobs—you can qualify for CREI home study training. (Electronics experience is not required for admission to CREI Residence School.) Check coupon if you prefer residence or home study information . . . or write, Capitol Radio Engineering Institute, Dept. 36-F, 3224 16th St., N.W., Wash. 10, D. C. If eligible for training under the new G.I. Bill of Rights, check the coupon for full information.

**TAKE A MINUTE TO MAIL THIS COUPON FOR FREE BOOKLET!**

#### **CAPITOL RADIO ENGINEERING INSTITUTE**

ECPD Accredited Technical Institute Curricula—Founded 1927  
Dept. 36-F 3224 Sixteenth St., N.W., Washington 10, D. C.

Please send me your course outline and FREE illustrated Booklet, "Your Future in the New World of Electronics" . . . describing opportunities and CREI Home Study courses in Practical Electronic Engineering Technology.

CHECK  Radar, Servo and Computer Engineering Technology  
FIELD OF  Electronic Engineering Technology  
GREATEST  Broadcast (AM, FM, TV) Engineering Technology  
INTEREST  Television Engineering Technology  
 Aeronautical Electronic Engineering Technology Z,  
 Automation and Industrial Electronics Engineering Technology

Name ..... Age .....

Street .....

City ..... Zone ..... State .....

CHECK:  Home Study  Residence School  Korean Veteran

To obtain fast, immediate service and to avoid delay, it is necessary that the following information be filled in:

EMPLOYED BY .....

TYPE OF PRESENT WORK .....

EDUCATION: YEARS HIGH SCHOOL .....

OTHER .....

ELECTRONICS EXPERIENCE .....

**VIDEO ELECTRIC COMPANY says: DOWN WITH RISING COSTS OF ELECTRON TUBES  
OVER ONE MILLION USED TUBES TO SELECT FROM at only**

Each and every tube is tested by our supplier under actual operating conditions in Radio, FM, Hi-Fi, Industrial Equipment and Television Chassis or Intricate Testing Equipment for Mutual Conductance and Life Test.

BELOW IS A PARTIAL LIST OF OVER THREE HUNDRED POPULAR TYPES! WRITE FOR FREE COMPLETE LIST AND ORDER BLANK!

- |       |        |       |          |           |        |
|-------|--------|-------|----------|-----------|--------|
| 0A2   | 5X8    | 6B8G  | 6S5F     | 7Z4       | 198G6G |
| 0Z4   | 5Y3GT  | 6B8K  | 6S7      | 12A8      | 19J6   |
| 1A7GT | 5Y4G   | 6B8K5 | 6S7      | 12A9S     | 19T8   |
| 1B3GT | 6A7    | 6B8K7 | 6SK7     | 12AT6     | 24A    |
| 1H4G  | 6A8    | 6B8N6 | 6SL7GT   | 12AT7     | 25AV5  |
| 1H5GT | 6AB4   | 6B8Q6 | 6SN7GT   | 12AU6     | 25BQ5  |
| 1L4   | 6AC7   | 6B8Q7 | 6SQ7     | 12AU7     | 25DN6  |
| 1L6   | 6AF4   | 6B8Q7 | 6S57     | 12AV6     | 25L6GT |
| 1N5GT | 6AG5   | 6B8Q7 | 6S57     | 12AV7     | 25W4GT |
| 1Q5GT | 6AG7   | 6B8Q7 | 6S57     | 12AX4GT   | 25Z5   |
| 1R5   | 6AH4GT | 6C4   | 6T4      | 12AX7     | 26     |
| 1S5   | 6AH6   | 6C5   | 6T8      | 12AZ7     | 35A5   |
| 1T4   | 6AK5   | 6C6   | 6V6      | 12B4      | 35B5   |
| 1U4   | 6AL5   | 6C6   | 6W4GT    | 12BA6     | 35C5   |
| 1U5   | 6AL7   | 6C6   | 6W6GT    | 12BA7     | 35L6GT |
| 1V2   | 6AM8   | 6C6   | 6X4      | 12BE6     | 35W4   |
| 1X2   | 6AN8   | 6C6   | 6X5      | 12BF6     | 35Y4   |
| 2A3   | 6AQ5   | 6C6   | 6X8      | 12BH7     | 35Z5GT |
| 2AF4  | 6AQ6   | 6C6   | 6Y6G     | 12BQ6     | 37     |
| 2F4   | 6AQ7GT | 6C6   | 7A4/XXL  | 12BR7     | 39/44  |
| 3B5   | 6AR5   | 6C6   | 7A5      | 12B7      | 42     |
| 3B6   | 6AR5   | 6C6   | 7A6      | 12CA5     | 43     |
| 3B8   | 6AS5   | 6C6   | 7A7      | 12J5      | 45     |
| 3C6   | 6AT8   | 6C6   | 7A8      | 12K7      | 50A5   |
| 3CF6  | 6AU4GT | 6C6   | 7B4      | 12L6      | 50B5   |
| 3CS6  | 6AU5GT | 6C6   | 7B5      | 12M7      | 50C5   |
| 3LF4  | 6AU6   | 6C6   | 7B6      | 12Q7      | 50L6GT |
| 3Q4   | 6AU8   | 6C6   | 7B7      | 12S7      | 50X6   |
| 3S4   | 6AV5GT | 6C6   | 7B8      | 12SK7     | 56     |
| 3V4   | 6AV6   | 6C6   | 7C4      | 12SN7GT   | 57     |
| 4BQ7A | 6AW8   | 6C6   | 7C5      | 12SQ7     | 58     |
| 4BZ7  | 6AX4GT | 6C6   | 7C6      | 12V6GT    | 71A    |
| 5AS8  | 6AX5GT | 6C6   | 7C7      | 12W6GT    | 75     |
| 5AT8  | 6B8    | 6C6   | 7E6      | 12X4      | 76     |
| 5AV8  | 6B8A   | 6C6   | 7E7      | 12Z3      | 77     |
| 5AW4  | 6B8B   | 6C6   | 7F7      | 14A7/12B7 | 78     |
| 5BK7  | 6B8C   | 6C6   | 7F8      | 14B6      | 80     |
| 5J6   | 6B8D   | 6C6   | 7H7      | 14Q7      | 84/6Z4 |
| 5T8   | 6B8E   | 6C6   | 7N7      | 19        | 117Z3  |
| 5U4G  | 6B8F   | 6C6   | 7Q7      | 19A4GT    | 117Z6  |
| 5V4G  | 6B8G   | 6C6   | 7X7/XXFM |           |        |
| 5V6GT | 6B8GG  | 6C6   | 7Y4      |           |        |



**GUARANTEE: WE GUARANTEE TO REPLACE FREE FOR ONE (1) YEAR ANY TUBE PURCHASED FROM US WHICH FAILS TO FUNCTION EFFICIENTLY UNDER ACTUAL OPERATING CONDITIONS. REFUNDS WILL BE MADE PROMPTLY FOR ANY DEFECTIVE MERCHANDISE. THE TUBES ADVERTISED HEREIN ARE NOT NECESSARILY NEW TUBES BUT MAY BE ELECTRICALLY PERFECT FACTORY SECONDS OR USED TUBES AND ARE SO MARKED.**

**WE HAVE OVER 1000 USED TV SETS**  
At All Times In Our Huge Warehouse. Buy one or more of these WORKING TVs to sell or use as your own second set! All sets in GOOD WORKING condition! Your Choice—Console or Table Model.  
10" ... \$23.00 19" ... \$58.00  
12" ... \$28.00 20" ... \$64.00  
14" ... \$23.00 21" ... \$72.00  
16" ... \$40.00 24" ... \$99.00  
17" ... \$46.00  
When ordering TVs, state whether console or table model or console is desired. Also, preference on make of set. All TVs sent rail-way express F.O.B. Newark. On any quantity, WIRE or CALL today!

**FREE**  
RCA "Cheater" Cord Given with Any Tube Order of \$7.00 or More!!

**FREE**  
Bonus Antenna Given with Any TV Set Order!!

SEND for our **FREE** complete **TUBE & PARTS LIST** and order blank.

**FREE POSTAGE**  
in U.S.A. and Territories on orders over \$5.00. 25c handling charge on orders under \$5.00. 25% deposit required on C.O.D.'s. Please send approximate postage or freight on Canadian and foreign orders. Subject to prior sale.

Phone **Humboldt 4-9848**

**VIDEO**

**ELECTRIC COMPANY**  
9-15 6TH ST., HARRISON, N. J.



## section I

### listen to the satellites

- building a satellite converter **10**  
the super satelliter antenna **16**



# build your satellite converter



This three-tube satellite converter (SC-3) is a highly sensitive unit that will receive and amplify the 108-mc. telemeter signal of an earth satellite or missile and *convert* it to a frequency that can be found and *identified* on the dial of your short-wave receiver.

Figure 1 is a block diagram of the converter circuit. Accuracy of the frequency of reception is determined by the frequency of the conversion crystal (fixed by the manufacturer) and the precision with which you tune your receiver.

If you tune your receiver near the easily identified signals of Station WWV (whose operating frequency is 10 mc.), you can obtain optimum 108-mc. reception with the SC-3. A simple connection between converter and receiver will feed the signal into the antenna circuit of your receiver.

## assembly

Before starting to assemble the converter, the chassis should be completely drilled according to the layout in Fig. 2. To insure proper wiring and assembly, the following instructions are given in a step-by-step sequence. The notation (NS) indicates that a connection should *not* be soldered, as other wires or components will be added shortly. The notation (S) indicates that a connection should be soldered before starting the next

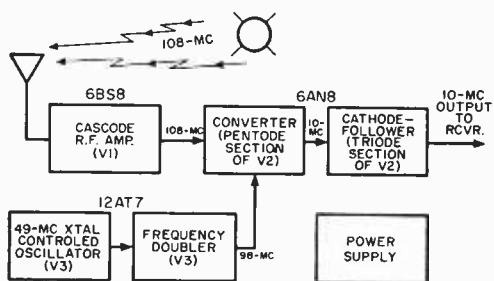

Fig. 1. Block diagram of converter chassis showing tube function.



Above-chassis view of completed converter. Tube line-up from front to rear is 6BS8, 6AN8, and 12AT7.



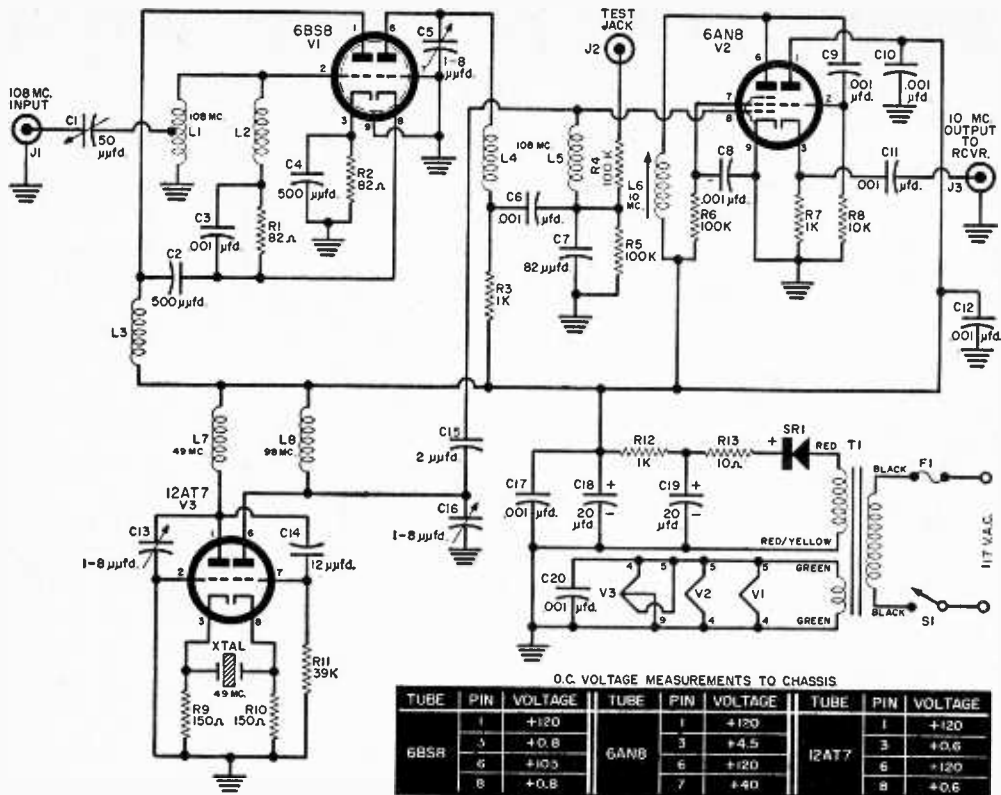

Fig. 3. Complete schematic of converter shows how dual tubes give six-tube performance.

### parts list

- C1—50- $\mu$ fd. variable capacitor (Bud LC-1644)
- C2—500- $\mu$ fd. ceramic disc capacitor (Centralab DD-501)
- C3, C6, C8, C9, C10, C11, C12, C17, C20—0.001- $\mu$ fd. ceramic disc capacitor
- C4—500- $\mu$ fd. feedthrough capacitor (Centralab ZB-501)
- C5, C13, C16—1-8  $\mu$ fd. variable trimmer capacitor (Erie 532-10 or Centralab 4324)
- C7—82- $\mu$ fd. ceramic disc capacitor, 5% tolerance (Centralab DTZ-82)
- C14—12- $\mu$ fd. capacitor
- C15—2- $\mu$ fd. capacitor (Centralab TCZ-1R5)
- C18, C19—20- $\mu$ fd., 150-volt electrolytic capacitor
- F1—1-ampere, 250-volt fuse with holder
- J1—Coaxial receptacle (Amphenol 83-1R) with plug (Amphenol 83-1SP)
- J2—Insulated pin tip jack
- J3—Phono-type jack with plug
- L1 through L8—See COIL DATA
- R1, R2—82-ohm,  $\frac{1}{2}$ -watt resistor
- R3, R7—1000-ohm,  $\frac{1}{2}$ -watt resistor
- R4, R5, R6—100,000-ohm,  $\frac{1}{2}$ -watt resistor
- R9, R10—150-ohm,  $\frac{1}{2}$ -watt resistor
- R8—10,000-ohm,  $\frac{1}{2}$ -watt resistor
- R11—39,000-ohm,  $\frac{1}{2}$ -watt resistor
- R12—1000-ohm, 1-watt resistor
- R13—10-ohm,  $\frac{1}{2}$ -watt resistor
- S1—S.p.s.t. toggle switch
- SR1—65-ma. selenium rectifier
- T1—Power transformer, 135 volts at 50 ma., 6.3 volts at 1.5 amp., 117-volt primary (Triad R-30X or Stancor PA-8421)
- TS1—8-lug terminal strip
- TS2—5-lug terminal strip
- Xtal.—49.0-mc. crystal (International Crystal Type FA-9)
- V1—6BS8 tube
- V2—6AN8 tube
- V3—I2AT7 tube
- 1—Miniature socket for FA-9 crystal (Millen 33302)
- 3—9-pin miniature sockets (one with shield)
- 1—3" x 5" x 7" aluminum chassis (Bud CU-2108)
- Misc. line cord and plug, knob, 6-32 and 4-40 nuts and bolts, soldering lugs, #22 tinned bare wire, #22 hookup wire

### coil data

L1, L4, L5 and L8 are cut from sections of pre-fabricated air-wound coil stock,  $\frac{1}{2}$ " in diameter, 16 turns per inch (Air-Dux #416—Ilumitronic Engr., Sunnyvale, Calif.). L1 has  $4\frac{1}{2}$  turns with  $\frac{1}{2}$ " leads; L4 has  $4\frac{2}{3}$  turns with  $\frac{3}{4}$ " leads, L5 has  $2\frac{2}{3}$  turns with  $\frac{3}{4}$ " leads, and L8 has  $3\frac{1}{2}$  turns with  $\frac{1}{2}$ " leads.

L2, L3, and L7 are close-wound with #30 enameled

wire on 1-megohm, 1-watt resistors approx.  $\frac{7}{16}$ " in diameter by  $\frac{1}{16}$ " long (IRC Type BTA). Coil leads are soldered to resistor leads close to body of resistor. L2 has 15 turns of wire, L3 has 33 turns, and L7 has 10 turns.

L6 has a value of approx. 44 microhenrys (J. W. Miller adjustable r.f. choke #4562)

(S). Pass a wire through center stud of *F* (S), through pin 9 (S) to ground lug 4 (S). Connect a wire from ground lug 3 (NS) of *F* to nearby ground lug 7 of terminal strip *TS1* (S). Press this lead against chassis.

- ( ) Connect wire to ground lug 1 of socket *J* (S), pass through pin 2 (S) to center stud of socket (NS). Connect wire to center stud (S) and pass through pin 9 (S) to ground lug 4 (S).

Wire the filament and power leads next with #22 stranded, insulated wire. Make sure the wire ends are twisted to avoid an accidental short circuit.

- ( ) Run a wire from pin 5 of socket *D* (S) to pin 5 of socket *F* (NS). Run a wire from pin 5 of socket *F* (S) to pin 5 of socket *J* (NS). Install jumper of solid wire between pin 5 (S) and pin 4 (NS) of socket *F*. Run one green lead of transformer *T1* to pin 4 (S) of socket *J*. Attach other green lead of *T1* to terminal 3 (ground) of strip *TS2* (NS).
- ( ) Wire terminal 5 of *TS1* (NS) to terminal 1 of *TS2* (NS). Wire terminal 1 of *TS2* (NS) to pin 1, socket *F* (NS). Wire terminal 8 of *TS1* (NS) to test jack *J2* (S). Attach one black lead of *T1* to one lug terminal of fuse *F1*'s holder (S). Attach the other black lead of *T1* to terminal 5 of *TS2* (NS). Attach the red lead of *T1* to the un-

marked (negative) terminal of rectifier *SR1* (S). Attach the red/yellow lead of *T1* to terminal 3 (ground) of *TS2* (S).

- ( ) Twist together two 14" lengths of hookup wire. Strip and tin both leads at one end. Attach one lead to each terminal of switch *S1* (S). Press the leads along the chassis edge and back to *TS2*. Attach one lead to terminal 5 of *TS2* (S). Attach the other lead to terminal 4 of *TS2* (NS). Pass the 117-volt line cord through grommet *P*. Tie a knot near the end of the cord. Attach one lead of the cord to the free terminal of fuse *F1*'s holder (S). Attach the other lead to terminal 4 of *TS2* (S).

### mounting

You are now ready to install some of the smaller components.

- ( ) At socket *D*: Install capacitor *C2* between pin 1 (NS) and pin 8 (NS). Trim leads as short as possible. (Lead length of all of the following connections should be kept at absolute minimum.) Install capacitor *C3* between pin 8 (NS) and the single terminal tie point *S* (NS). Install resistor *R1* between pin 8 (S) and tie point *S* (NS).
- ( ) Install coil *L2* between tie point *S* (S) and pin 2 (NS). Install coil *L1* between pin 2 (S) and ground lug *E* of

Fig. 4. Wiring of components on the two terminal strips should follow this layout. Make sure lugs 2 and 7 of *TS1* and 3 of *TS2* are well grounded to chassis.

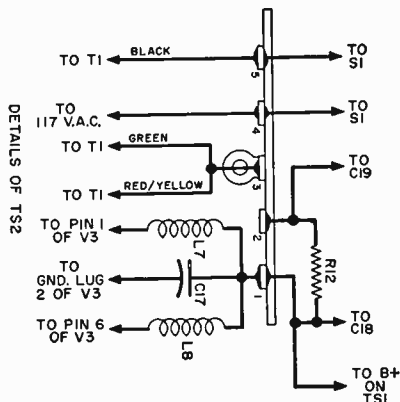
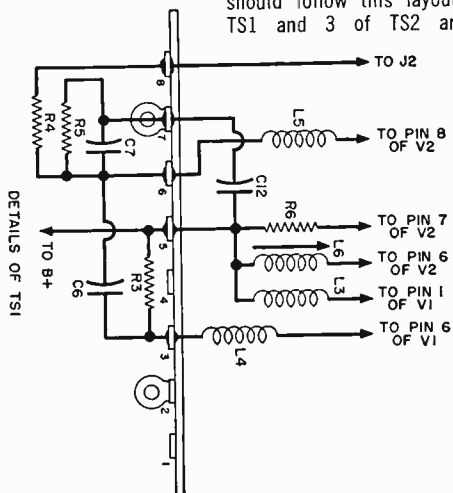

*J1* (NS). Install capacitor *C20* between pin 4 (S) and pin 5 (S). Mount capacitor *C5* in hole *T*. Attach wire lead from stator of *C5* to pin 6 (NS). Mount coil *L4* between pin 6 (S) and terminal 3 of *TS1* (NS). Mount coil *L3* between pin 1 (S) and terminal 5 of *TS1* (NS).

- ( ) Examine capacitor *C4*. The outer ring is one terminal, and the two inner lugs comprise the other terminal. Slide one inner lug of *C4* through the hole of pin 3 of socket *D* (NS). Orient the outer ring of *C4* so that it touches ground lug 2 of socket *D*. Holding *C4* in this position, solder pin 3. Next, solder the outer ring to ground lug 2. Trim the leads of *R2* and attach one lead to the free inner lug of *C4* (S); attach the other lead to ground lug *E* of *J1* (S).
- ( ) At terminal strip *TS1*: Install resistor *R3* between terminal 3 (NS) and terminal 5 (NS). Install capacitor *C6* between terminal 3 (S) and terminal 6 (NS). Slip insulated tubing over capacitor leads. Install resistor *R5* between terminal 6 (NS) and terminal 7 (ground) (NS). Install *R4* between terminal 6 (NS) and terminal 8 (S). Install capacitor *C12* between terminal 5 (NS) and terminal 7 (ground) (NS). Slip insulated tubing over leads. Install *C7* between terminal 6 (NS) and terminal 7 (S).
- ( ) At socket *F*: Install capacitor *C11* between center terminal of *J3* (S) and pin 3 of socket *F* (NS). Install *C10* between ground lug 1 (NS) and pin 1 (S). Install resistor *R8* between ground lug 1 (NS) and pin 2 (NS). Install capacitor *C9* between pin 2 (S) and pin 6 (NS). Slip insulated tubing over capacitor leads.
- ( ) Install resistor *R7* between ground lug 1 (S) and pin 3 (S). Install coil *L6* between pin 6 (S) and terminal 5 of *TS1* (NS). Use lengths of solid wire for coil leads. Install capacitor *C8* between ground lug 3 (S) and pin 7 (NS).
- ( ) Install resistor *R6* between pin 7 (S) and terminal 5 of *TS1* (S). Slip insulated tubing over resistor leads. In-

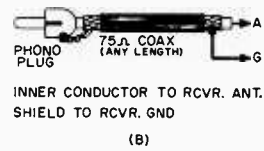
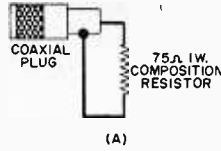
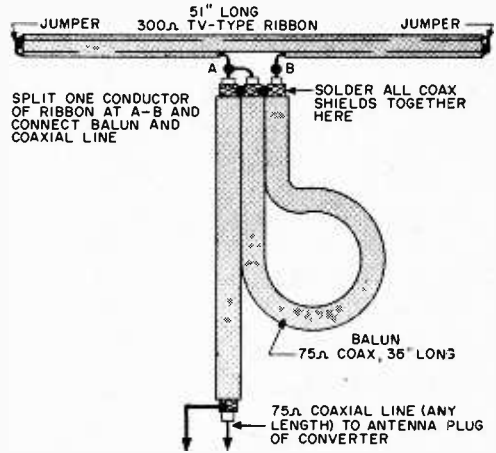

Fig. 5. Dummy load (A) for adjustment and interconnecting cable (B).

Fig. 6. On-the-air testing is done with a simple dipole antenna.



stall coil *L5* between pin 8 (NS) and terminal 6 of *TS1* (S).

- ( ) At socket *J* and *TS2*: Install capacitor *C16* in hole *H*. Attach wire lead from stator of *C16* to pin 6, socket *J* (S). Install capacitor *C15* between pin 8 of socket *F* (S) and the lead of *C16* (S). Install resistor *R12* between terminal 1 of *TS2* (NS) and terminal 2 of *TS2* (NS). Install coil *L8* between terminal 1 of *TS2* (NS) and the lead of *C16* (S). Install capacitor *C14* between pin 1 (NS) and pin 7 (NS). Install resistor *R11* between pin 7 (S) and ground lug 4 (S).
- ( ) Install capacitor *C17* between terminal 1 of *TS2* (NS) and ground lug 2 of socket *J* (S). Insert capacitor *C13* in hole *U*. Attach lead from stator of *C13* to pin 1, socket *J* (NS). Install coil *L7* between pin 1 (S) and terminal 1 of *TS2* (NS). Install resistor *R9* between ground lug 1 of socket *J* (S) and adjacent pin of crystal socket (NS). Install *R10* between ground lug 4 (S) and free pin of crystal socket (NS).

( ) Run wire from pin 3 (S) to nearest pin of crystal socket (S). Run wire from pin 8 (S) to remaining pin of crystal socket (S). Install capacitor *C18*. Attach negative lead to ground lug *M* (NS) and positive lead to terminal 1 of *TS2* (S). Install capacitor *C19*. Attach negative lead to ground lug *M* (S) and positive lead to terminal 2 of *TS2* (NS). Install resistor *R13* between positive terminal (cathode) of rectifier *SR1* (S) and terminal 2 of *TS2* (S).

( ) *Final connections:* Install antenna compensating capacitor *C1* in panel holes using 4-40 hardware. Make sure rotor of capacitor does not touch chassis. Install wire from rotor lug of *C1* (S) to center terminal of *J1* (S). Install wire from one stator terminal of *C1* (S) to tap point on coil *L1* (S). Place knob on shaft of capacitor. Install tube *V1* in socket *D* and place shield over tube. Place tube *V2* in socket *F* and tube *V3* in socket *J*. Place overtone crystal in socket. Place 1-ampere fuse *F1* in fuse holder.

### circuit adjustment

Before applying power to the converter, check your wiring against Fig. 3. For circuit adjustment, you will need a high-impedance vacuum-tube voltmeter and a grid dip oscillator.

Plug a dummy antenna, as shown in Fig. 5 (A), into receptacle *J1*. All of the following tests should be conducted using the dummy antenna.

Turn on the converter and make sure that all tubes light. Measure the various d.c. voltages as indicated at the bottom of Fig. 3; a reading within 10% or so of the indicated value will be considered normal. Finally, adjust the VTVM to the -5 volt scale, and insert probe in test jack *J2*. This reading gives an indication of the oscillator injection into the converter stage.

Capacitor *C13* should be slowly adjusted until a reading is obtained on the meter. The multiplier stage capacitor, *C16*, is now tuned to maximize the reading. With proper adjustment of these two controls, a reading of -3.5 volts should be obtainable. Under

### editor's note

The construction of this project has been simplified as much as possible, but at the high frequencies involved there are many intangible pitfalls. For example, mounting wire connected to a grid or plate circuit close to the chassis might add enough capacitance to prevent the tuned circuit from being adjusted properly later. An extra half inch of wire connected to a coil might similarly prevent proper operation.

If you have built units operating at similar frequencies, you have learned how to handle such critical circuits. Equipped with a VTVM and a grid dip oscillator, you are off to a good start.

proper operating conditions, circuit *C13-L7* is tuned to 49 mc. and circuit *C16-L8* to 98 mc.

Because of minute variations in tubes and components, and because the trimmer capacitors (*C5*, *C13*, *C16*) cover only a limited range, the resonant frequency of a circuit might fall just outside the range of adjustment of the trimmers. Under normal circumstances, the trimmer slugs should resonate about half-way in the capacitor. If the slug appears to reach resonance when it is fully within the capacitor, it indicates that inductance of the coil is a little too low. The addition of one turn to *L7* (if the setting of *C13* is out of line), or the addition of 1/4-turn to *L8* (if the setting of *C16* is out of line) will bring the circuit into alignment. Conversely, if the slug of either capacitor resonates when it is fully withdrawn from the shell, the inductance of the associated coil is a little too great. Turns should be removed as suggested above. When both tuned circuits are "on the nose," the required voltage will be obtainable at the test jack.

When the converter is connected to your receiver, as shown in Fig. 5 (B), the "background noise level" of the receiver should increase sharply. A random-length wire can be attached to input receptacle *J1* for this test. If the GDO is now tuned to 108 mc., its signal should be audible in the receiver. Many cities have test transmitters on 108 mc.

The test signal will resemble an unmodulated carrier. When you find it, tune capacitors *C1* and *C5* to enhance the signal level. Resonate the slug of coil *L6* to 10 mc. to provide maximum signal into the receiver. A slight adjustment (perhaps 1/2-turn) of coils *L1* and *L2* may be required for exact resonance.

# the super -satelliter antenna

by *donald l. stoner, w6tns*

*convert a simple TV antenna into a souped-up job for satellite signals*

Our earth satellites can be heard clearly with the help of the Super-Satelliter. As this is written, the whir of the six-inch "Vanguard" and the bell-like tone of the "Explorer" make them easy to identify. Occasionally they interfere with each other—the first QRM from outer space.

This antenna is used in conjunction with the satellite converter described in the previous article. On the basis of several months of experience, it has provided the most outstanding reception, on 108 mc., of the various designs tested.

As the transmitter of the satellite generates only a tiny amount of power, a high-gain antenna is best for receiving the signal. Although a Yagi is very sensitive, it is also very directional. For best results, it must be turned toward the satellite to "track" it as it zooms along its orbit. A vertical dipole or ground-plane antenna is not directional, but

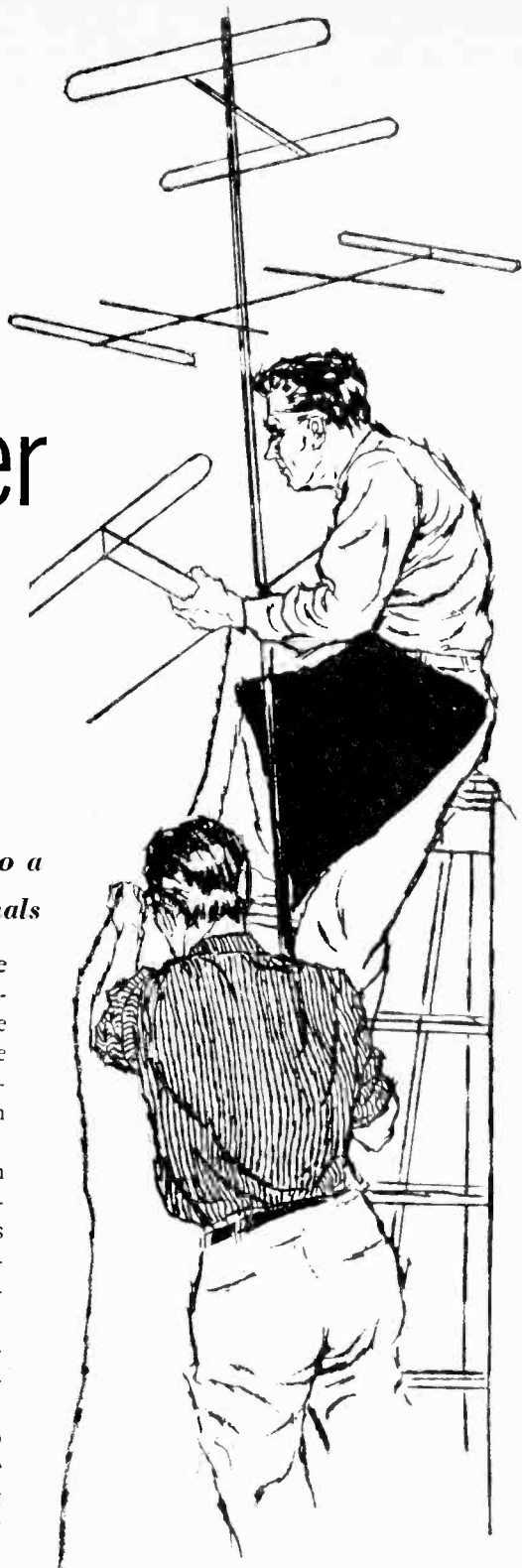



it's not very sensitive either. The Super-Satelliter is a compromise between these extremes. Although technically a Yagi, it is less directional.

In this installation, the antenna is permanently directed west. It receives all passes of the satellite equally well. One pass may be from southwest to northeast. Approximately 12 hours later, it may pass the same point traveling northwest to southeast. The antenna is sensitive in both directions, with the signals from the front favored slightly.

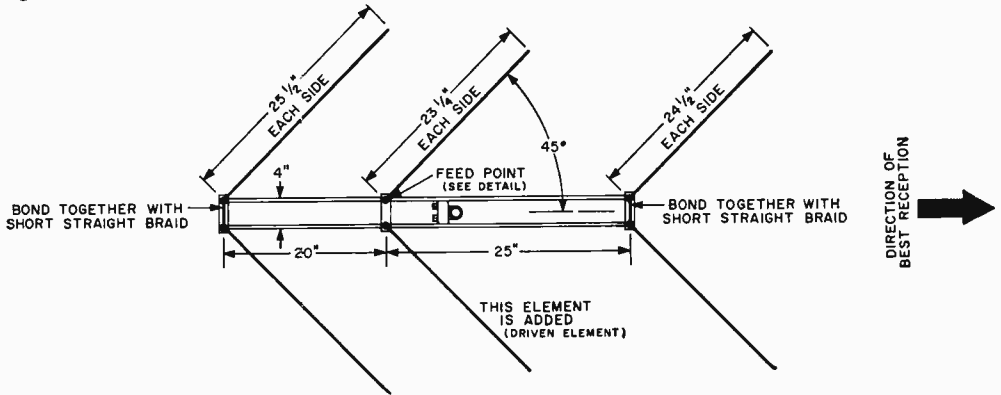

Modify double-Vee antenna as shown in diagram above. Detailed drawing of feed point is given below.

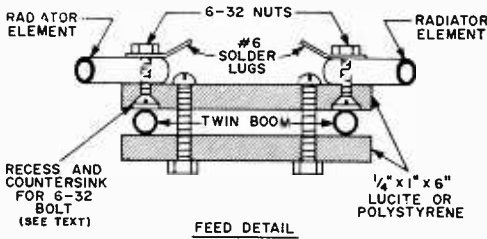

You can make the Super-Satelliter by modifying a standard double-Vee television antenna. Originally it consisted of four rods supported on plastic blocks mounted on two  $\frac{1}{4}$ " aluminum booms. These elements are positioned at a  $45^\circ$  angle to a bisecting line to make the antenna less directional.

Start the modifications by cutting each of the front elements (the director) off at  $24\frac{1}{2}$ ". Next, cut the rear elements (the reflector) down to  $25\frac{1}{2}$ ". Now, since open tubes will wail in the wind, crimp the ends of the rods.

Drill a  $\frac{1}{16}$ " hole in each reflector rod at the boom end. With self-tapping screws, connect them with a short length of braid.

You can get braid by stripping it off a length of shielded cable. If you are unable to obtain braid, a short piece of copper wire will make a satisfactory substitution although it will have a bit more loss. Connect the director rods together the same way.

To complete the antenna, you'll have to construct new driven elements. These consist of two additional rods,  $23\frac{1}{4}$ " long and the same diameter as the reflector and director. Your local television repair shop should be able to sell you some rod material. You

will also need two pieces of polystyrene or Lucite measuring  $1" \times 6" \times \frac{1}{4}"$ . Refer to the detail drawing to see how these plastic pieces clamp on each side of the boom.

Drill two  $\frac{1}{8}$ " holes in each block between the booms. Keep the holes close to the booms to prevent the plastic from bending. Directly above the point each boom will run, drill a  $\frac{1}{8}$ " hole and countersink it to a  $\frac{1}{8}$ " depth. File two grooves in the top side of this block, at a  $45^\circ$  angle, to support each rod. The radiator mounting screws should *not* contact the twin booms.

Drill and mount each rod with countersunk 6-32 bolts, installing a solder lug under each nut used to secure the rod. To the solder lug of one, connect the braid; to the other, connect the center conductor of a length of 52-ohm coaxial cable (either RG/8U or RG/58U). The coaxial cable runs between the antenna and the satellite converter input. Clamp the plastic pieces across the booms with 6-32 bolts long enough to hold.

Before erecting the antenna, check the countersunk bolts visibly, and with an ohmmeter. There should be no danger of a short between the bolt heads and the boom.

# GET MORE ENJOYMENT OUT OF YOUR HI-FI FOR ONLY \$1.00!

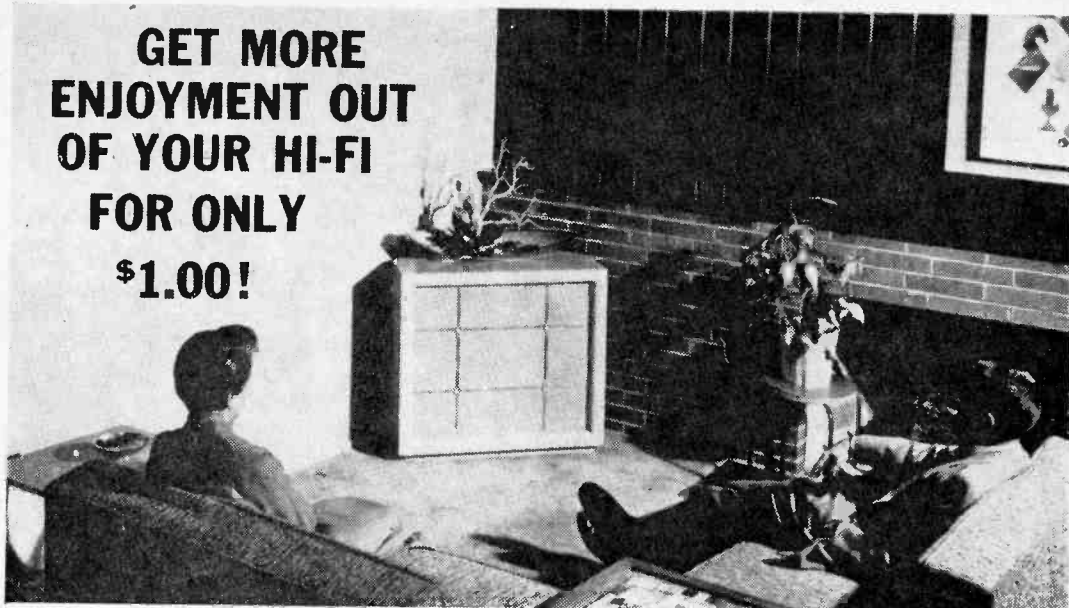

photo courtesy Electro-Voice, Inc.

Now—just \$1 can show you how to get more listening pleasure from your hi-fi set! That's the cost of the new 1959 edition of the HI-FI GUIDE & YEARBOOK—the authoritative Ziff-Davis Annual that covers every facet of high fidelity enjoyment. Besides telling you how to use your equipment for the best possible reproduction, the 1959 HI-FI GUIDE & YEARBOOK presents a round-up of the trends in the hi-fi field... tells you how to save on repairs... guides you in the selection of records... gives you tips on tapes.

You'll find this Annual a wonderfully practical source of information on improving the sound output of your system. Articles are presented in easy-to-understand, non-technical language. No wonder the HI-FI GUIDE & YEARBOOK has been a virtual sellout in other years! Be sure to reserve your copy of the 1959 edition now. It's like getting two big books for the price of one:

## GUIDE

Section 1: IMPROVING YOUR HI-FI—Strange Allergies of hi-fi. Square Waves Check Tone Controls. Give Your Pickup a Chance. Getting the Most from Your Tweeters. MS means Multiplex. Your Stereo Listening Area.

Section 2: INSTALLING YOUR HI-FI SYSTEM—Hi-ing the Fi to the Suburbs. Index Your Music. Ceiling Mounted Speaker.

Section 3: TAPE RECORDING—Getting the Most from Your Tape Records. Tips and Techniques. Don't Let Your Tapes Hiss at You. Make Your Own Stereo Tape Recordings.

## YEARBOOK SECTION

TRENDS IN HI-FI: developments in 1958 and what the future holds.

CRITICS' CHOICE OF RECORDINGS: a conductor, a music critic, and a sound engineer tell what records (classical and jazz) they would select—and why.



THE ULTIMATE IN FM STATIONS: Here's how an FM station in Chicago really caters to its hi-fi listeners—in what could be a nationwide trend in programming! Also gives you a listing of FM stations throughout the country.

STEREO: the latest report on what is happening in this big, exciting field. Plus a photo story showing what can be done to fit more equipment into less space. All told, the HI-FI GUIDE & YEARBOOK brings you a wealth of information to help you get the most out of your hi-fi listening hours. Only \$1.00 (\$1.25 outside U.S.A.) it's a fabulous, buy! Make sure you reserve your copy at your newsstand.

On sale March 24

**ZIFF-DAVIS PUBLISHING COMPANY**

434 South Wabash Avenue, Chicago 5, Illinois





## section ■■

### for your hi-fi

one tube hi-fi AM tuner	<b>20</b>
tuner + audio = radio	<b>22</b>
transistorized preamp & control unit	<b>24</b>
make your own arm	<b>27</b>
hi-fi slave	<b>29</b>
switch to stereo	<b>32</b>
improving your low-cost phono arm	<b>35</b>
slot box your speaker	<b>36</b>



# Hi-Fi AM Tuner

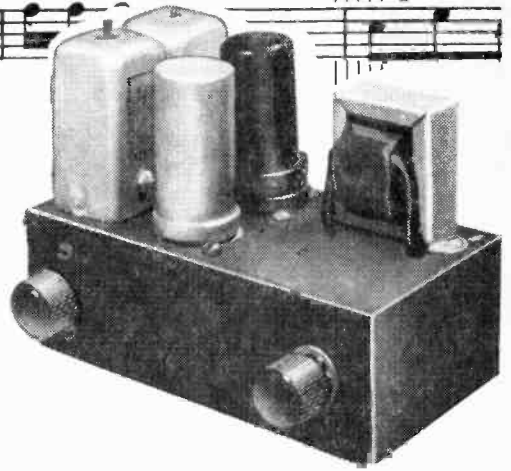
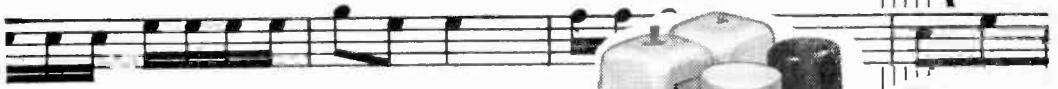

An old standard, the 6SK7 tube, is used as an r.f. amplifier, and is paired with a 1N34A or CK705 as a tuned diode detector. A selenium rectifier eliminates the need for a tube in the power supply.

Antenna length is not critical—just use a long enough wire to give adequate audio signal output. A volume control with an on-off switch is shown in the photos and diagrams; this can be eliminated if the high-fidelity amplifier to which the tuner is connected already has one.

The components are mounted away from the power transformer, as shown in the top view of the chassis above, to prevent possible pickup of hum. Follow the pictorial diagram below for best results in building the tuner.

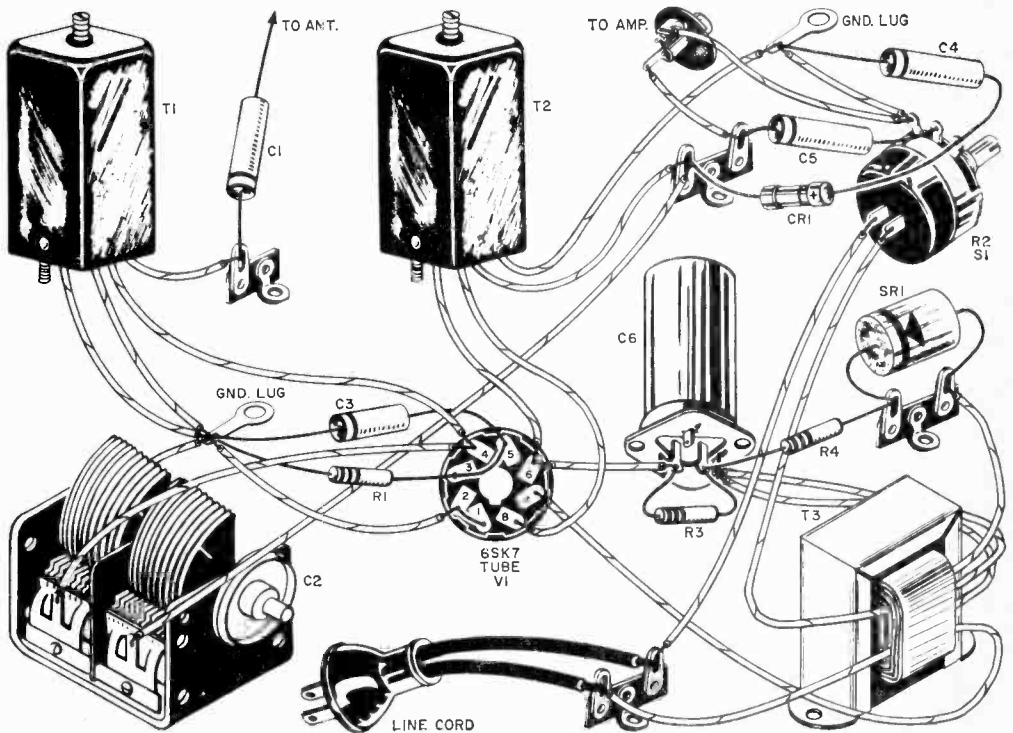

by leon a. wortman

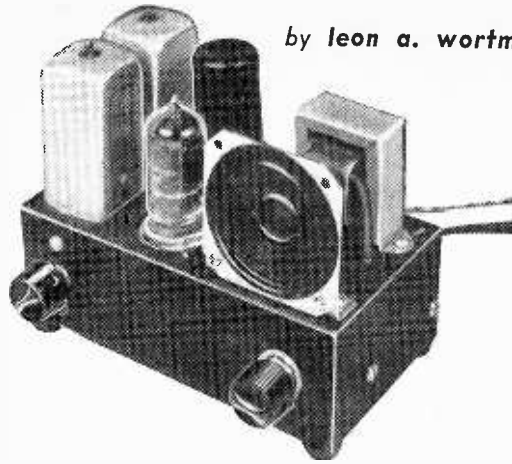

# Tuner + Audio = Radio

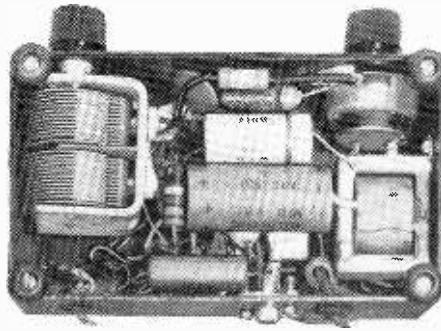

IF YOU HAVE already constructed the "One-Tube Hi-Fi AM Tuner" described in the previous article, this article will show you how to convert it to a complete radio by adding one more tube, a few components, and a small loudspeaker.

The chassis for the entire *tuner-radio* measures only  $5\frac{1}{4}'' \times 3'' \times 1\frac{1}{8}''$ . Of course, other chassis sizes will do, provided you have room for the parts. You can reduce the chassis size by making use of the miniature coils and capacitors now available.

To convert the tuner to a radio, all you have to do is add an amplifier and speaker on the same chassis. In the original tuner, the filter capacitor,  $C6a/C6b$ , is an upright can type. If you remove it and substitute a dual tubular-type electrolytic which can be mounted under the chassis, you will have space for a 12AU7 tube ( $V2$ ) and its 9-pin socket.

One triode section of  $V2$  serves as a voltage amplifier for the output of the diode detector and the second triode section is the output amplifier. The output transformer ( $T4$ ) is installed under the chassis, just back of the volume control.

Some reorientation of parts may be necessary if you are converting from the original

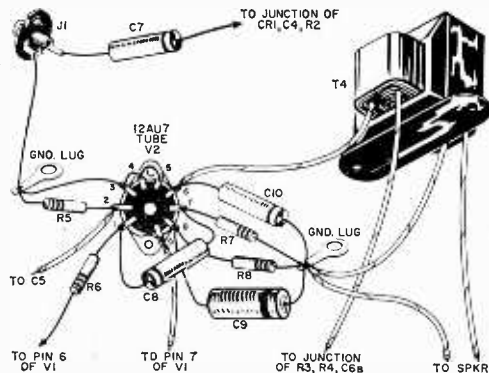

ELECTRONIC EXPERIMENTER'S HANDBOOK

tuner construction. Little difficulty should be experienced, however, because there are no critical stages in the design.

A phono jack is mounted at the rear of the chassis which permits the unit to be used as either a self-contained radio or as a tuner for your hi-fi system. Capacitor *C7* is connected from the "high" side of volume control *R2* to this jack. Since the audio output signal of the tuner is not affected by *R2*, this permits the exclusive use of the volume control on your hi-fi amplifier for controlling the tuner.

The shielded cable between the output of the tuner and the input of your hi-fi amplifier should be kept to less than 4' in length.

Adding loudspeaker operation to your tuner has several advantages. The miniature speaker will act as a "monitor" and allow you to tune in a station with your hi-fi system volume turned down, and save yourself the headache-provoking output of interstation noise that would normally come rushing through your big amplifier.

When the unit serves as a radio, the audio output is limited in tone quality by the small loudspeaker. A baffle consisting of a small piece of Celotex with a circular opening cut in it will do wonders for some of the lower frequencies.

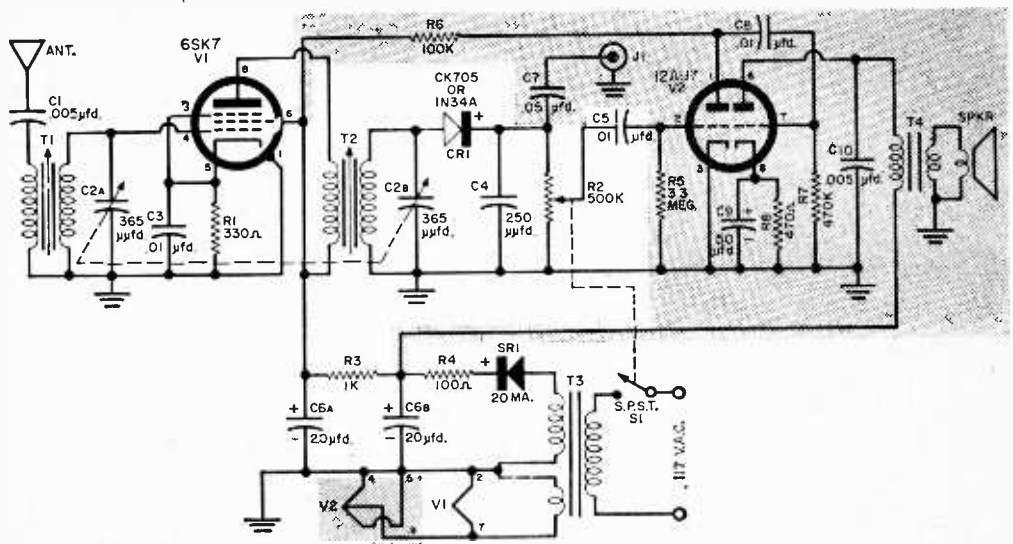

Portions of the schematic and the new parts shown in the shaded sections above indicate the areas in which changes or additions are made to convert the tuner to a radio. A shielded or unshielded socket may be used for the 12AU7 wiring shown in the pictorial at left.

### parts list

C7—0.05- $\mu$ fd., 400-volt capacitor  
 C8—0.01- $\mu$ fd., 400-volt capacitor  
 C9—50- $\mu$ fd., 25-volt electrolytic capacitor  
 C10—0.005- $\mu$ fd., 400-volt capacitor  
 J1—Phono jack  
 R5—3.3-megohm,  $\frac{1}{2}$ -watt resistor

R6—100,000-ohm,  $\frac{1}{2}$ -watt resistor  
 R7—470,000-ohm,  $\frac{1}{2}$ -watt resistor  
 R8—470-ohm,  $\frac{1}{2}$ -watt resistor  
 Spkr.— $2\frac{1}{2}$ " loudspeaker  
 T4—Output transformer, 8000-10,000 ohm plate to voice coil (Stancor A3328)  
 V2—12AU7 tube

# TRANSISTORIZED

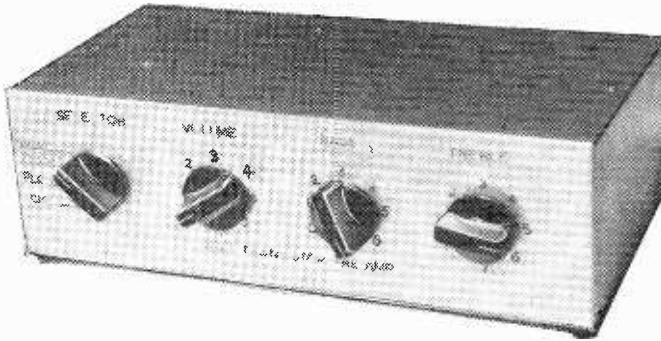

## PREAMP and CONTROL UNIT

*Avoid hum and noise with an all-transistor hi-fi preamplifier*

*by tracy diers*

The transistor has been on the electronic scene just a few short years but it has already proved itself superior to vacuum tubes in many applications. For hi-fi fans, it's a boon, because good quality can frequently be achieved with much less effort than is required with vacuum tubes. There is no hum or noise mixed with the music and no power supply problems.

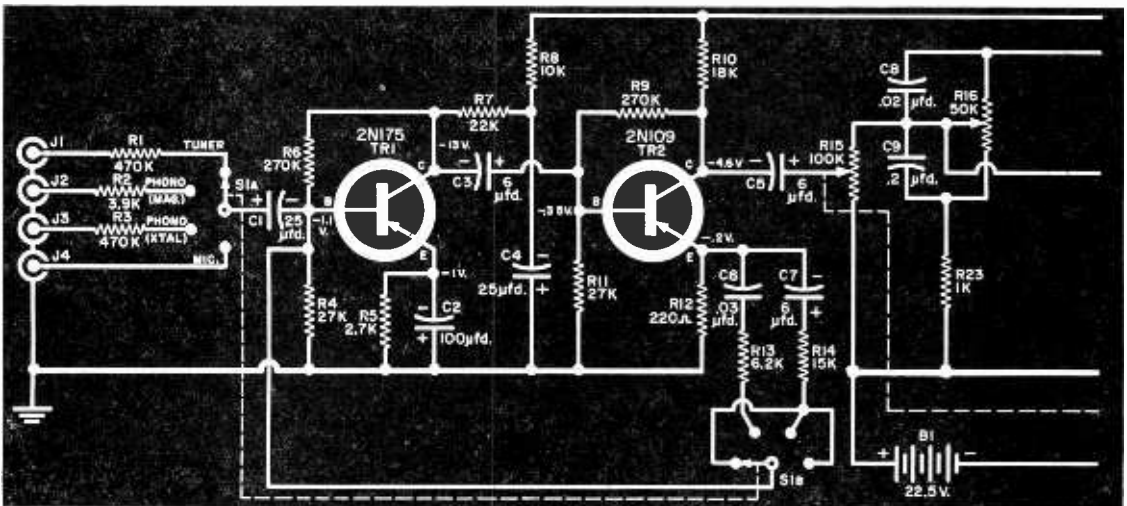



The equalizer-preamp to be described will meet with the approval of the most critical hi-fi listener, and the cost of construction is amazingly low. Three RCA transistors are used. As the noise level of the unit is mostly dependent on TR1, an RCA 2N175 was chosen because of its low-noise characteristics. The second and output stages use the RCA 2N109.

First prepare the aluminum box which houses the circuit board. It is a 5" x 10" x 3" aluminum chassis. After the chassis has been drilled, you can letter the control panel using a lettering guide or decals.

The circuit is wired on a 7 $\frac{1}{2}$ " x 2 $\frac{3}{4}$ " perforated phenolic board. Parts placement is not of great importance. However, because of the very high gain of the circuit, it's wise not to run the signal output wires too close to those handling input voltages.

Components are mounted as shown on both sides of the phenolic board. Flea clips are used as tie points and terminal connections. No attempt has been made to miniaturize this unit, and to extend battery life, the largest 22.5-volt unit available is employed.

Use sockets for the transistors and place them in a position where they can be reached easily when the phenolic board is mounted in the chassis box. A small right-angle bracket should be bolted to each end of the board for use during mounting.

When the wiring of the component board is completed, place it in the chassis as close to the controls as possible. Mark the chassis where the angle brackets line up, and drill two screw holes for mounting the board brackets. Now connect flexible leads from appropriate flea clips on the board to the front panel controls.

Check with the schematic often, as you can easily make a mistake here, especially at the selector switch (S1). Wires which run the length and width of chassis should be tucked under chassis lip for neatness. Use shielded wire to connect the input jacks to S1.

Test for the proper current drain with low voltage before applying the full 22.5 volts. Connect a three-volt battery (two size D cells) to the battery input wires with a milliammeter in series. Observe the correct polarity and you should get a meter reading of 300  $\mu$ a. (0.3 ma.) or less.

If no reading is obtained, check for an open circuit. If 1 ma. or more is read, check for incorrect transistor connection. If you remove all transistors and find that the reading is still excessive, there is a circuit error.

When you obtain the correct current flow (100-300  $\mu$ a.), hook up the 22 $\frac{1}{2}$ -volt battery. The current which the preamp takes with 22.5-volt battery will be about 2.4 ma.

Connect the output of the preamp to the input of the basic amplifier and plug your tuner into the proper jack. Turn the volume up about half way and adjust the tone controls.

### how it works

A feedback circuit comprising R13 and C6 or R14 and C7—depending on the setting of selector switch S1, Section B—is connected from the emitter of TR2 to the base of TR1. This circuit reduces distortion and smooths the frequency response.

When S1 is set in the Phono 1 (Mag.) position, Section B automatically connects R13 and C6 into the feedback loop and the preamp circuit provides the correct playback compensation (RIAA) for modern LP records. Section A of S1 selects the proper cartridge load when S1 is in the Phono 1 (Mag.) position. In other positions, Section A determines the degree of attenuation necessary to prevent overload of TR1.

When a crystal or ceramic cartridge is used and S1 is set in the Phono 2 (Xtal.) position, record compensation will not be automatic and the tone controls may need adjustment to provide the correct tonal balance. The tone control portion of the preamp has a range of  $\pm 15$  db on both the bass and treble and should be able to match most crystal cartridge frequency characteristics.

Following this stage, the signal is passed into TR3. The low output impedance of TR3, about 18,000 ohms, limits the high-frequency loss which may occur due to a long output cable.

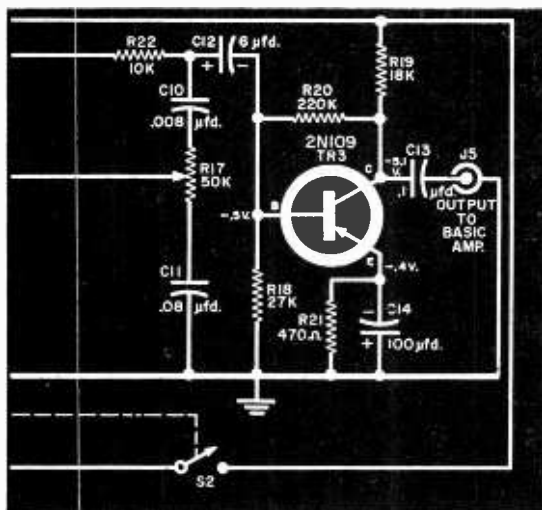

## parts list

- B1—22½-volt battery (Burgess 4156 or equivalent)  
 C1, C4—25- $\mu$ fd., 25-volt electrolytic capacitor  
 C2, C14—100- $\mu$ fd., 15-volt electrolytic capacitor  
 C3, C5, C7, C12—6- $\mu$ fd., 25-volt electrolytic capacitor  
 C6—0.03  $\mu$ fd.  
 C8—0.02  $\mu$ fd.  
 C9—0.2  $\mu$ fd.  
 C10—0.008  $\mu$ fd.  
 C11—0.08  $\mu$ fd.  
 C13—0.1  $\mu$ fd.  
 J1, J2, J3, J4, J5—RCA type phono jack  
 R1, R3—470,000 ohms  
 R2—3900 ohms  
 R4, R11, R18—27,000 ohms  
 R5—2700 ohms  
 R6, R9—270,000 ohms  
 R7—22,000 ohms  
 R8, R22—10,000 ohms  
 R10, R19—18,000 ohms  
 R12—220 ohms  
 R13—6200 ohms  
 R14—15,000 ohms  
 R15—100,000-ohm potentiometer with switch S2 (volume)  
 R16—50,000-ohm potentiometer (bass)  
 R17—50,000-ohm potentiometer (treble)  
 R20—220,000 ohms  
 R21—470 ohms  
 R23—1000 ohms  
 S1—2-pole, 4-position rotary switch (selector)  
 S2—On-off switch on R15  
 TR1—2N175 transistor (RCA)  
 TR2, TR3—2N109 transistor (RCA)  
 1—Perforated board (Lafayette MS-306)  
 12—Flea clip terminations (Lafayette MS-263)

All capacitors, unless otherwise noted, are ceramic types, 25-volt or higher rating.

All resistors  
 ½ watt

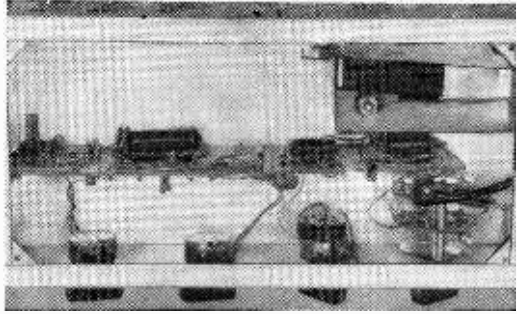

Beneath the chassis, the preamp looks like this. The battery is mounted at top, right, and held in place by an aluminum bracket insulated with electrical tape.

Try your pickup cartridge next. If you have a magnetic cartridge of the type which requires considerable amplification, you will get that amplification—and without hum!

On the author's unit, the "flat" response settings for the tone controls are approximately at the 12 o'clock position. You can determine the *exact* flat position for your preamp easily but you will need an audio signal generator and a VTVM and/or scope.

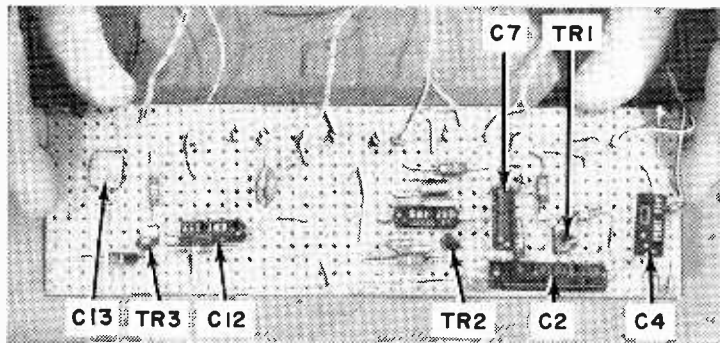

Both sides of the phenolic wiring board are shown at right. The components are "threaded" onto the board and held in place by their leads. Any capacitor value not available may be made up by wiring two capacitors in parallel whose values total the desired capacitance.

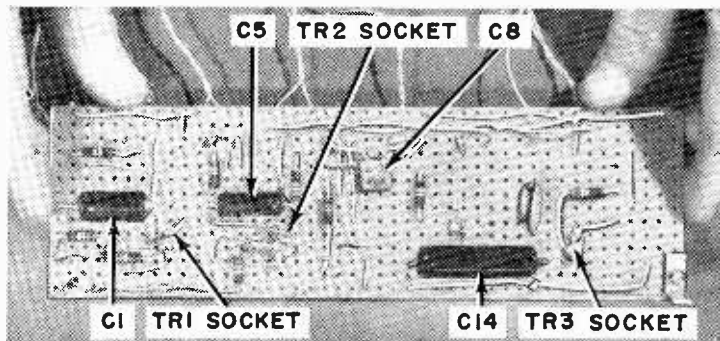

Completed pickup arm shown at right requires the addition of thin, flexible, shielded lead to carry the signal from the cartridge to your hi-fi amplifier.



Here is a phonograph arm which is simple, has few moving parts, and is remarkably well adapted to use with hi-fi turntables designed for playing single records. It has a more or less conventional head angle which tracks well with most cartridges, standard mounting holes for cartridges, and better-than-average resonance characteristics.

The arm can be made of hardwood, Lucite, or aluminum, and the fittings required can be obtained at most electrical supply houses for a few cents. Outside of your own labor, which is not much at all, the whole assembly will only cost between \$1.50 and \$2.00!

All finished dimensions are shown on the next page. They should be adhered to as closely as possible, especially the location of holes for mounting cartridges in the head, and the mounting hole for the arm. It would be a good idea to make your own template actual size from the diagram showing the top view and trace this directly onto the material you are using.

If wood is used, smooth one face with sandpaper for clear tracing. If aluminum is used, polish one side with ordinary steel wool to clean it. In cutting out the material, keep a bit outside the tracing lines so you can finish it off to size later with a file or sandpaper. This should be done before drilling the holes.

Drill hole "B" (at back end of the arm) and holes "D" and "E" (for cartridge mounting) with a No. 31 drill, and thread them with a 4-40 tap. Holes "D" and "E" are drilled clear through, but hole "B" need only be about  $\frac{1}{2}$ " deep. Hole "A" should be drilled clear through parallel to the thickness of the material marked X in the diagram on page 28 (top view), with a  $\frac{3}{32}$ " drill.

The arm mounting hole "F" is made by drilling two  $\frac{1}{4}$ " holes, one  $\frac{1}{8}$ " to the left of the center line and one  $\frac{1}{8}$ " to the right of it. Carefully file out the "flat" portion to com-

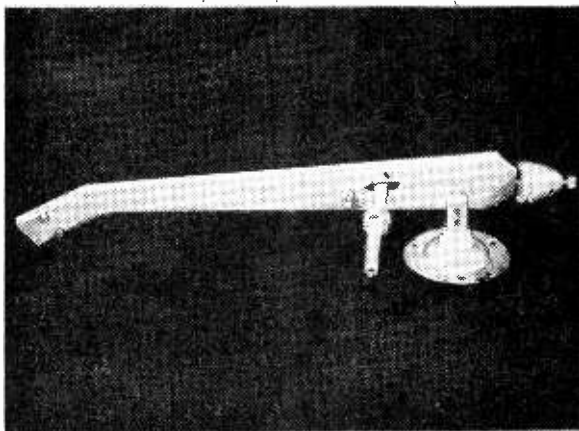
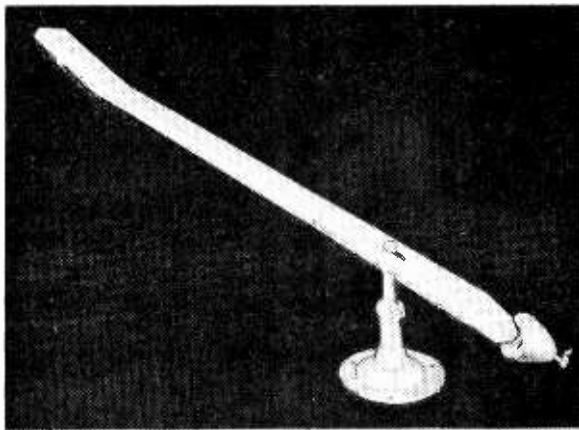

**MAKE YOUR OWN ARM**

*... for high-fidelity results at low cost*

*by leonard c. holzer*

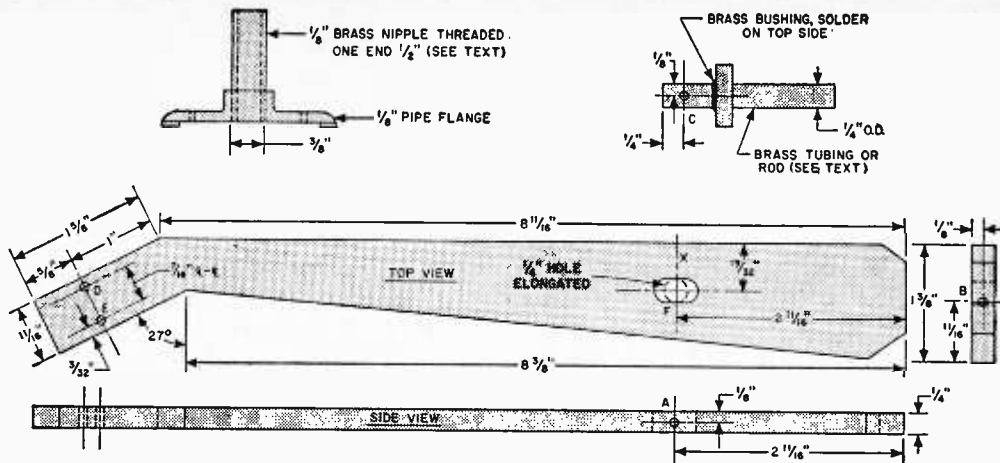

Template and construction details of the home-made arm are given above. A choice of material is available for the body of the pickup arm. The lettered points in the diagram refer to specific construction details which are covered in the text.

plete the elongated hole in the tone arm.

This completes the arm part itself. It can be polished and the edges rounded for a smooth finish. If wood is used, a light coat of model lacquer may be desirable.

Make the mounting base before the tubing part is completed. Screw pipe flange and nipple together firmly, noting that the nipple does not extend below the base of the flange.

To get the correct height of the nipple and assembled parts, insert the brass tubing into the arm mounting hole, and slip through the  $\frac{3}{32}$ " rod. It should fit smoothly but not loosely, so that the arm can hinge up and down (through the hole in the side of the arm).

With your motor and turntable mounted on its baseboard, set the flange with its center about  $7\frac{1}{8}$ " from the center of the spindle of the turntable. Slip the brass tubing with arm mounted into the brass nipple (ream out with  $\frac{1}{4}$ " drill if necessary).

Mount the cartridge in place on the arm. Its needle should be about  $\frac{1}{8}$ " beyond the spindle center when it is swung over this point. With a record on the turntable, place the needle in the groove and note the position of the arm. It should be parallel with the turntable surface. If it is not, note the position of the nipple and brass tubing. About  $\frac{3}{4}$ " of the brass tubing must show above the nipple to allow the arm to move up and down, so mark the nipple to be cut off to permit this dimension.

Cut off the tubing (if necessary) to extend within only about  $\frac{1}{4}$ " from the bottom of the nipple in the flange. The tubing must not touch the mounting board surface or it won't turn freely. Remove the tubing and arm from the nipple and cut both parts to size.

Smooth the top of the nipple as squarely as possible and polish it with fine emery. Slip it over the brass tubing to the  $\frac{3}{4}$ " mark, and put on the brass bushing from the other end. Holding nipple and tubing firmly in this position, apply solder to the top of the bushing (end away from the nipple) all around to join it solidly to the tubing. Now remove the nipple, and polish the tubing and undersurface of the bushing with steel wool.

Reassemble all parts, check that arm moves freely up and down as well as in a circular direction, oil the surface of the tubing, the inside of the nipple, and the  $\frac{3}{32}$ " rod where it contacts the surface of the tubing. This completes the arm.

To counterbalance the arm to proper cartridge weight, note the weight prescribed by the manufacturer and, using a 4-40 screw (in hole "B" at the back of the arm), attach a brass washer and apply solder to it until the arm counterbalances the proper stylus weight.

### bill of materials

- 1— $\frac{1}{4}$ " x  $1\frac{1}{2}$ " section of hardwood, Lucite or aluminum, about 12" long
- 1—3" length of  $\frac{1}{4}$ "-o.d. brass tubing
- 1—3" length of  $\frac{1}{8}$ " brass nipple, threaded on one end
- 1— $\frac{1}{8}$ " electrical pipe flange (Leviton or equiv.)
- 1—Brass bushing,  $\frac{1}{4}$ " hole,  $\frac{3}{16}$ " thickness (approx.)
- 1—2" length of  $\frac{3}{32}$ " brass rod

# hi-fi slave

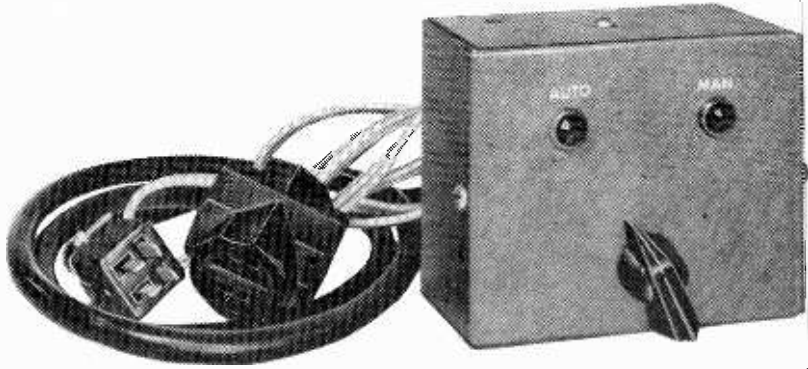

*this genie in a box turns off your complete record playing system after the last disc has been played*

by **robert m. duff**

Did you ever get up in the morning and find your hi-fi amplifier still on? Build this slave unit! Once set, it will play the selected program and then turn off all the equipment, including itself, or leave it on, depending on the setting.

The slave costs less than \$6, and can be mounted in its own case or on a control panel. It must be used with a changer that has an automatic cutoff.

There are no tubes or high-priced parts. The most expensive item is a double-pole, double-throw, 117-volt relay. Cost can be reduced by eliminating the indicator lamps.

## construction

If your record changer has a four-pole motor, its *built-in* automatic shutoff switch may be located in the lead connecting the two field coils. If so, disconnect the two wires from the shutoff switch and solder them together. Disconnect the line cord. Then connect a lead from the first motor terminal to the shutoff switch.

If the shutoff switch is *not* wired between the coils in your unit, make the conversion connections as shown in the schematic on page 30.

Solder the red conductor from the four-conductor cable to the same point. Connect one side of the line cord to the *other* terminal of the shutoff switch. Solder the black conductor to this same switch terminal. Now connect the white and green conductors and the other leg of the line cord to the second motor terminal.

When installing the back panel of the slave unit case, make certain that wiring from the four-conductor cable does not cause interference with relay operation.

## operation

Plug the slave unit into the changer connector, and plug the amplifier or other units to be controlled into a triple socket. Set the selector knob to *Man*. The red lamp should light, and the amplifier or other equipment should turn on. (Don't forget to plug in the changer and set the amplifier on-off switch to "on.")

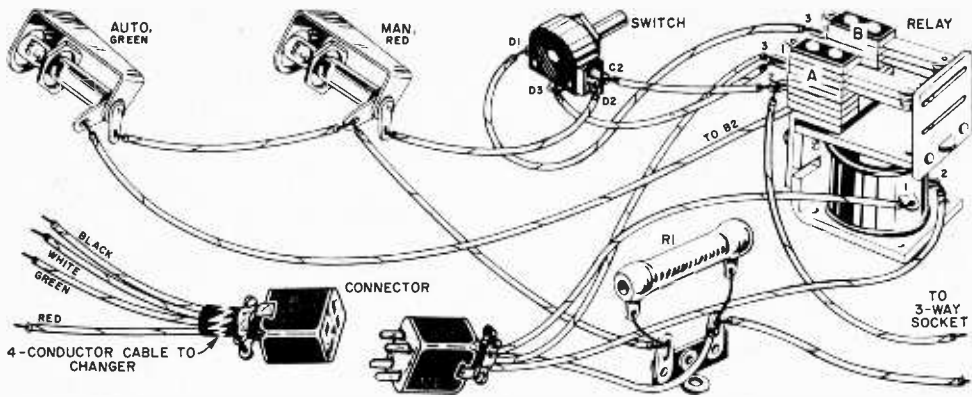

Pictorial above shows complete wiring for slave. At right are all sides of unit case with drilling instructions and dimensions.

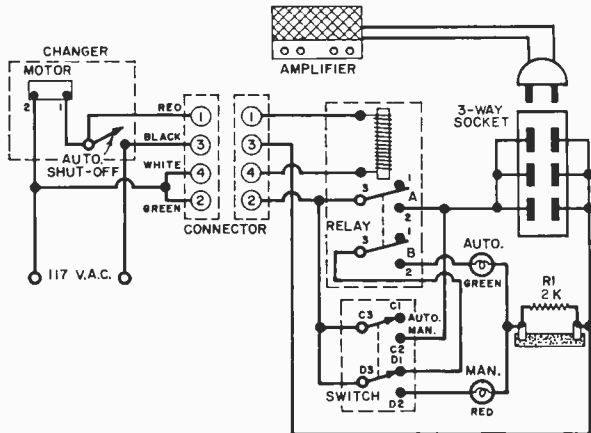
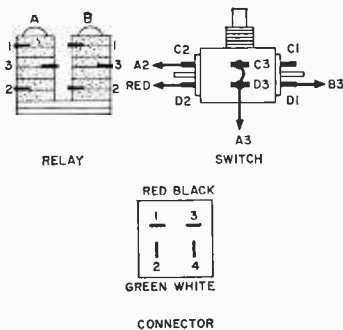
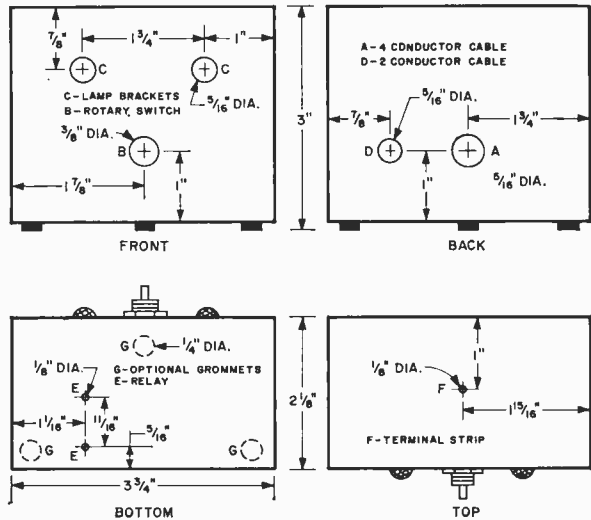
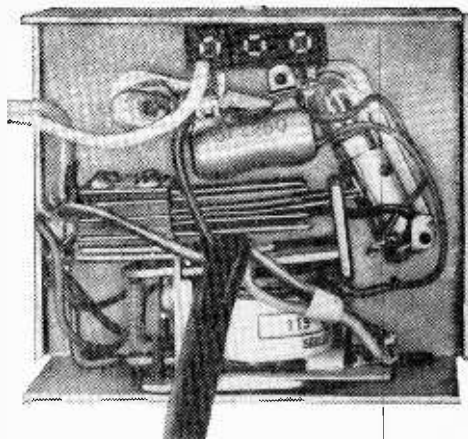

Diagram above contains terminal identification for relay, switch and connector. Underside of switch is shown. When mounted, C1 and D1 will be on red lamp side. Schematic at right shows how to wire the "Genie in the Box."

## parts list

- R1—2000-ohm, 5-watt resistor
- 1—117-volt, 60-cycle relay, with d.p.d.t. contact assembly (Guardian Universal Series 200 Coil and 200-4 Contact Assembly)
- 1—Male and female connector pair, four-pin type with cable clamp (Cinch-Jones Type P-304-CCT and S-304-CCT)
- 1—D.p.d.t. rotary switch (Hart and Hegeman Type 81727)
- 2—Pilot light assemblies (Dialco Series 710)
- 2—28-volt a.c. bayonet-type lamps (GE #1819)
- 1—Length of four-conductor cable
- 1—Length of two-conductor cable and extension-cord cube-tap a.c. socket
- 1—3 x 3 3/4 x 2 1/8" aluminum case (ICA channel-lock type)
- Misc. rubber grommets, bolts and nuts, tie lug strip, lock washers, etc.



View of components in case. Switch is behind relay coil. Lamp brackets must not interfere with leaves.

Now set the selector knob to *Auto*. If the tone arm is at rest and the turntable off, the amplifier and green lamp will turn off. With the selector knob at *Auto*, lift the tone arm and set it on the record, causing the turntable to start. A sharp click should be heard as the relay is energized, the green lamp will flash on, and the amplifier will begin to warm up.

Push the changer reject button to simulate the end of the last record. When the change cycle is completed and the tone arm comes to rest, another click will be heard as the relay releases; the green lamp and the amplifier will turn off.

If, during the playing of a record, the selector knob is turned to *Man.*, the green lamp will go off and the red lamp will go on (the amplifier will remain on). At the end of the record, a click will be heard when the relay releases, but the amplifier will *not* turn off.

If a tape machine is used as the program source, a microswitch will do the same job as the changer's automatic shutoff switch. Many tape machines have a microswitch which stops the machine when the tape runs off the supply reel. If the tape machine does not have such a microswitch, one can be installed in the tape transport path very inexpensively.

## how it works

Since a record changer is the most common program source, one is shown in the schematic on page 30. However, a tape machine can also be used.

Most record changers have an automatic shutoff switch which turns off the turntable when the tone arm has come to rest at the end of the last record. This operates the control relay. When the relay is energized, contact A2 completes a circuit to the equipment plugged into the triple socket. Contact B2 completes a circuit to the green lamp if the selector switch is set at *Auto.*, so that contact D1 supplies power to contact B3.

If the selector switch is set at *Man.*, the equipment is supplied power through switch contact C2, and the red lamp is supplied power through contact D2, whether or not the relay is energized. With the selector switch at *Man.*, the green lamp cannot be lit even if the relay is energized, because relay contact B3 is not receiving power through switch contact D1.

One side of each lamp goes to B2 and D2, and the other side goes to a common resistor, R1, which is used to drop the line voltage to about 28 volts—the value of the lamps. One resistor is sufficient, since only one lamp will be operating at a time.

This circuit permits either automatic or manual operation. On *Auto.*, the changer cutoff switch operates the relay which supplies power to the equipment and the green lamp. On *Man.*, power is supplied to the equipment and the red lamp through the selector switch alone. This allows all on-off switches in the various pieces of equipment to remain in the "on" position.

To turn the equipment on, set the selector switch to *Man.* When it is warmed up, program material can be played. When it is finished, the switch in the changer will turn off, and the relay will de-energize, but the hi-fi equipment will remain on.

However, when the equipment is warmed up and the turntable started, the selector switch can be turned to *Auto.* This places control on the relay. When the changer switch turns off the relay, the contacts open, turning off the power to the equipment, including the power to the green lamp.

The relay provides foolproof operation, and mechanical independence from the changer. It also allows a current up to 12.5 amp. to be drawn through the relay contacts instead of through the changer switch contacts, which are not rated for this current.

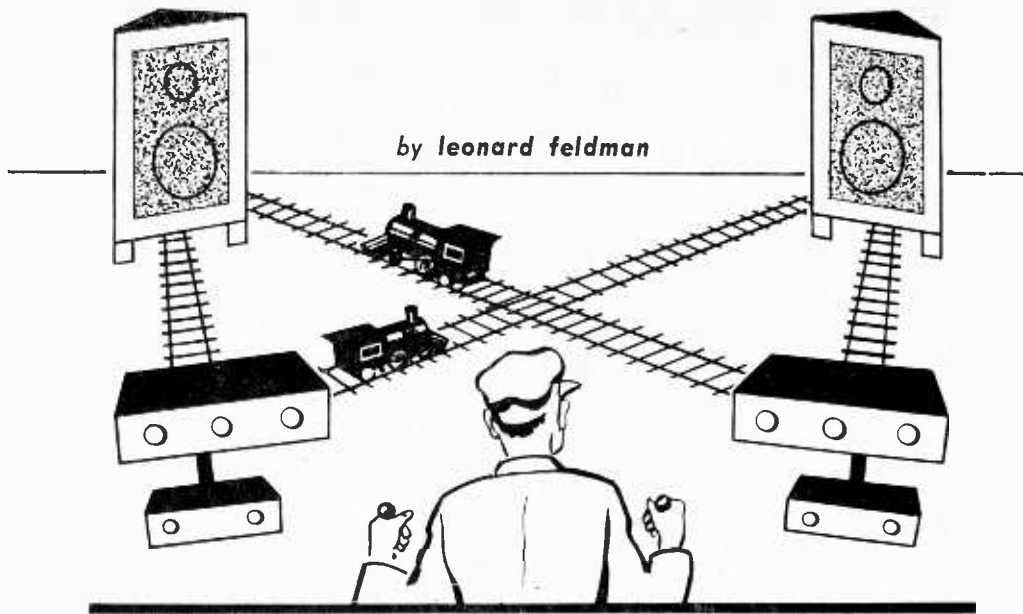

## SWITCH to STEREO

*add flexibility to your hi-fi system so you can listen  
to stereo or monophonic programs*

Many hi-fi fans are adding an additional channel to their existing equipment to obtain stereo reproduction. This is a matter of economics—it is generally the least expensive method.

One drawback to such an installation is its lack of flexibility compared to a new dual amplifier-preamplifier combination. While the front panel of such a combination usually resembles the control board of an electronic computer, the knobs perform extremely important functions.

For one thing they offer switching provisions for feeding *either* a monaural signal or the two channels of a stereo signal to *both* speakers. In this way, both speakers are always in use and full amplifier power is available. With two separate amplifiers, you might just as well turn one of them off when you listen to a monaural source, for the amplifier in use is connected to only *one* speaker of your pair.

### **channel reversing**

At the present time, while there is general standardization as to which half of the tape is left channel and which is right (to some extent, this is also true of discs and cartridges), it's convenient to be able to reverse channels by flipping a switch. Most stereo amplifiers and preamplifiers feature such a switch on the front panel. In a two-



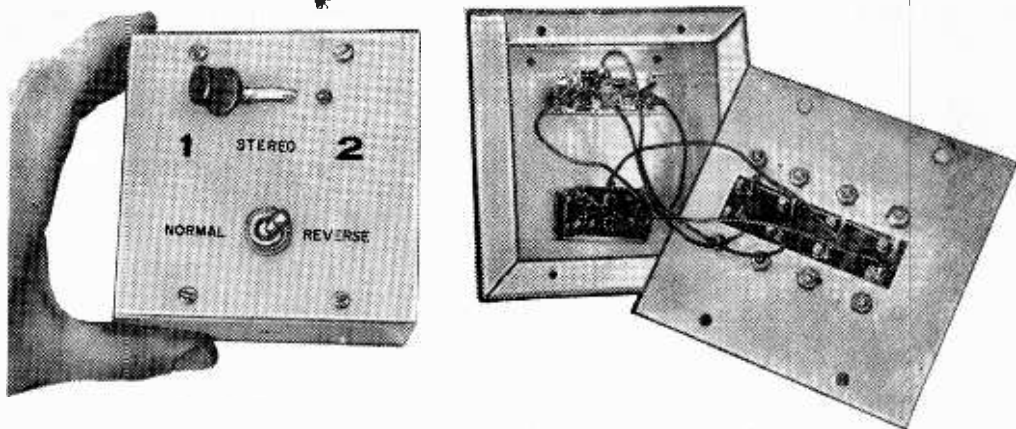

amplifier setup not so equipped, about the only thing you can do to reverse channels is manually to disconnect and reverse the left and right speakers or input.

### **balancing**

Each amplifier will have its own volume control, of course. If all sources of stereo were perfectly balanced (right with respect to left), you could easily learn the optimum settings of these controls. Unfortunately, the settings for phono will certainly be different from the settings for stereo radio broadcasting (AM-FM, or, eventually, FM-multiplex), which will in turn be different from the settings for your stereo records.

What's more, unless your pair of volume controls is located within arm's reach of your best listening area, you may end up jumping up and down a dozen or more times trying to adjust each volume control for best results. What appears to be balanced sound when you are off to one side is far from balanced when you center yourself between the two speakers.

### **the stereo switch**

The first two "aids to flexible stereo" can be accomplished without tearing into any of the electronic circuits of your two amplifiers. Switching from monaural to stereo and speaker reversal are combined in an easy-to-build device.

Because these two functions can be performed *after* the amplifiers (that is, between amplifier and speaker), a double advantage results: the wiring is simple and not subject to hum and noise problems and the control can be conveniently installed at your listening position.

### **construction details**

The controls are built into an aluminum chassis-box measuring 4" x 4" x 2". Size is not critical, however. The front panel contains a three-position lever switch and a double-pole, double-throw toggle switch. The rear sports four two-terminal screw type terminal strips, two for amplifier outputs from each amplifier and two for connection to the two speaker systems.

The "common" or ground sides of the amplifier inputs and speaker output terminals are tied together. Besides simplification in wiring, this insures proper phasing of both amplifiers with respect to each other and with respect to the speakers being used.

A schematic diagram of the switching system explains the actions of the switches. The lever switch (double-pole, three-position) is shown in the AMP I position. In this

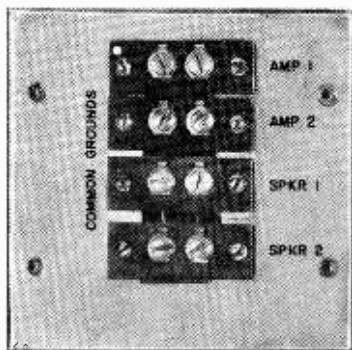

In this adapter, no switch position is included to provide for playing monophonic LP's with a stereo cartridge. Check the cartridge manufacturer for special connections required. See schematic at right. Pictorial (above, right) shows how to connect function switch. Photos above and at left show completed stereo switch and its interior.

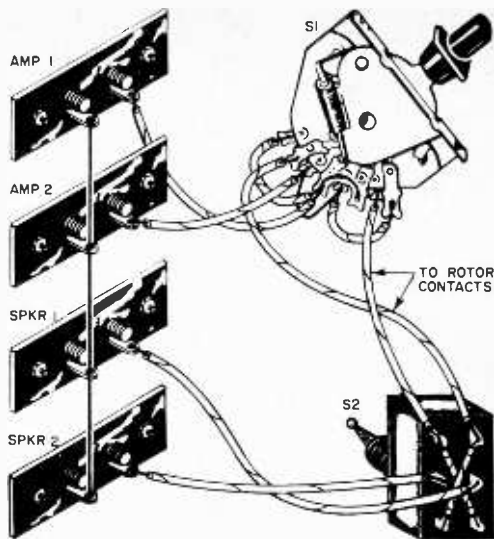

### parts list

- S1—2-pole, 3-pos. lever switch (Centralab 1454)
- S2—D.p.d.t. toggle switch
- 1—2"x4"x4" aluminum cabinet
- 4—Bakelite terminal strips, two-terminal screw type
- Misc. 6-32 machine bolts and nuts, solder, wire

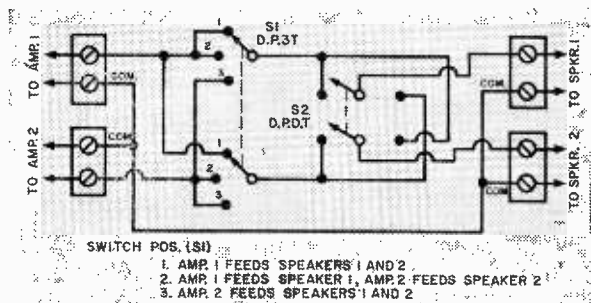

position, whatever signal is coming from amplifier 1 will be fed to *both* speakers. When the lever switch is moved to stereo position, the signal from AMP 1 will be connected only to SPKR 1 and the signal from AMP 2 will be fed only to SPKR 2. Finally, when the lever is thrown to AMP 2 position, whatever signal is developed in the second amplifier will be applied to *both* speakers.

The toggle switch labeled NORMAL and REVERSE is functional only when the lever switch is in the STEREO position. At that time, if it is thrown to REVERSE, the signal from AMP 1 will be fed to SPKR 2 and the signal from AMP 2 will feed SPKR 1. Obviously, when *either* amplifier is feeding *both* speakers, it doesn't matter what position the NORMAL-REVERSE switch is in.

In connecting the two amplifiers to the input terminal strips of the switch box, it is essential that the "common" or "ground" terminal of each amplifier be connected to the "common" side of each input terminal

strip. If you are using two identical speaker systems, connect the *same* terminal of each speaker to the "common" terminals of the two-output strips. To do otherwise would result in an "out-of-phase" condition between the two speakers which would tend to reduce the stereo effect.

If you plan to use two speakers of different model number or manufacture, you will have to "phase them out" before connecting them to the switch box. By applying the voltage from a small flashlight battery to the terminals of each speaker, it is a simple matter to determine that connection which results in similar motion of each cone. Label the terminals + and -, and connect the same signs to the common, and the opposite signs to SPKR 1 and 2.

From the schematic, position 3 of the switch results in doubling the available monaural inputs with 2 speakers.

If you find the strings and tympani reversed, just flick the normal-reverse switch.

# Improve Your Low-Cost Phono Arm

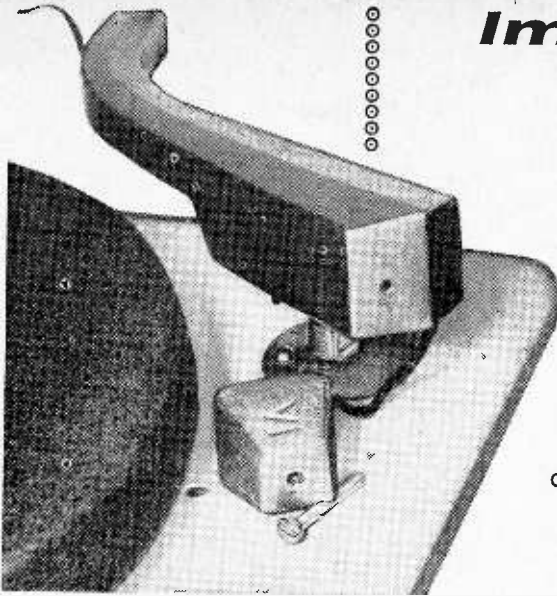

by  
**leonard c. holzer**

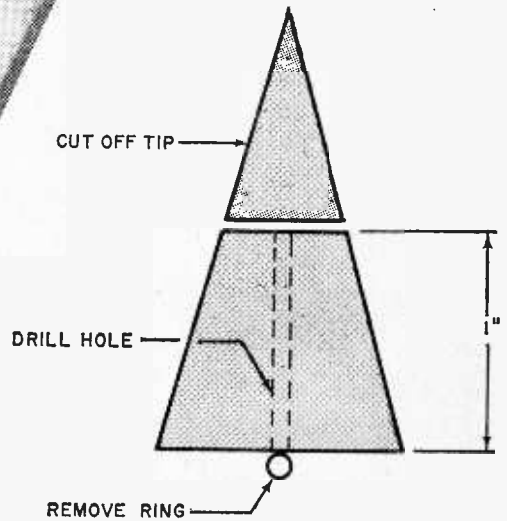

One of the differences between a hi-fi tone arm and the arm in the average home phonograph is in the balancing or "loading" mechanism. The usual inexpensive tone arm has little mass and its spring-loading tends to make it unstable and overly sensitive to floor vibration. However, much can be done to improve such an arm.

We start out with a pyramid-shaped six-ounce fisherman's sinker weight (which can be obtained at any fishing tackle retailer) and a #6 machine screw. Cut the top off the sinker and drill a hole through its center. If you have a 6-32 tap, you can drill the hole with a #36 drill and then thread it; if not, you can drill it with a  $\frac{3}{16}$ " bit.

Remove the spring from the arm and mount the weight with its small surface facing the back of the arm. Use a screw or nut and bolt. With the small surface against the rear of the arm, stylus pressure is less than with the larger surface against the arm. Using a stylus pressure gauge, mount the weight in the position that provides the recommended stylus pressure for your phono cartridge.

If the stylus pressure is too light regardless of which way you mount the sinker, you will have to file off some of the weight. Keep checking with the gauge; once the correct stylus pressure is found, no further adjustment will be required unless you substitute a different cartridge.

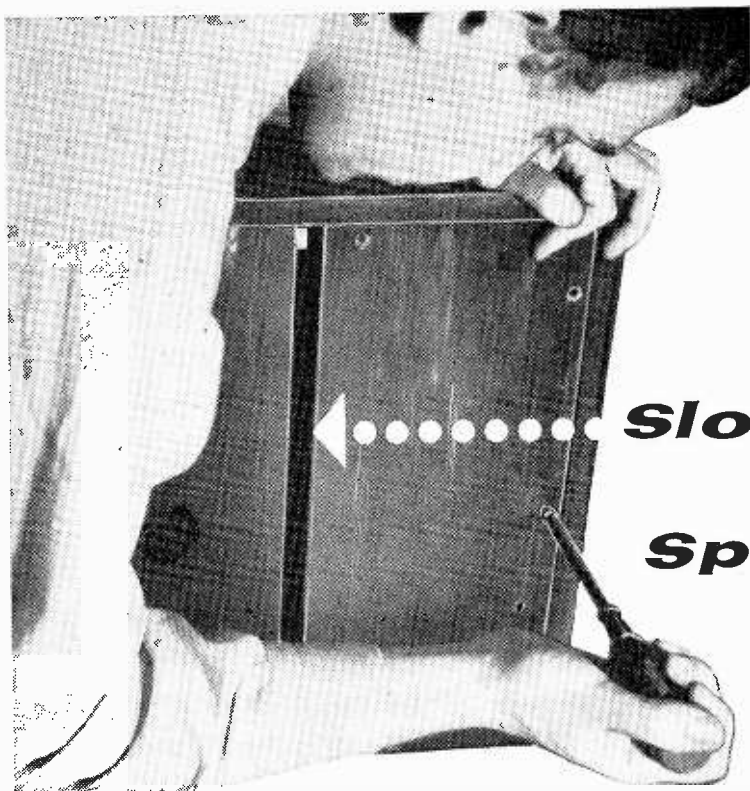

by  
jeff markell

## **Slot-Box Your Speaker**

*You get BIG sound out of a small space  
with this inexpensive and easy-to-build enclosure*

To the hi-fi fan of modest means and limited room, the problem of acquiring a speaker enclosure that will provide good sound and at the same time occupy a small space is paramount. My solution to the problem is simple, inexpensive, and gives gratifying results.

The entire enclosure measures 16" x 16" x 12" and can be put almost anywhere. You can leave it on the floor, hide it in a corner, or hang it on the wall. It's not very heavy. It could be built as part of a larger piece of furniture that serves other purposes. Or it could be incorporated as part of a bookcase since it is only 12" deep.

### **low cone resonance**

The unit is designed primarily for use with 8" and 10" speakers although there are a good many other suitable ones.

The principle of this friction port enclosure is fairly simple. One of the main reasons a speaker has trouble operating in a completely closed box of small dimensions is that when it tries to make the large excursions necessary to reproduce the bass notes there isn't enough "give" to the small amount of air trapped in the box. As a result, the cone is sharply damped at the low end, and the bass resonance moves up in frequency, thereby causing a rather unpleasant, boomy response.

In this enclosure, before the air pressure inside can build up enough to affect the speaker, air will start moving through the Fibreglas-covered slot in the back. This allows the speaker sufficient freedom of movement at the low end and still maintains a desired degree of air loading.

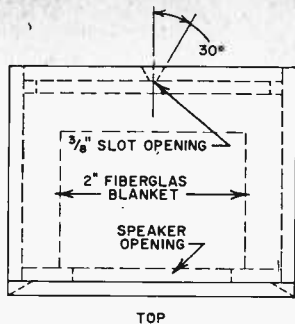

PLAIN BUTT JOINT

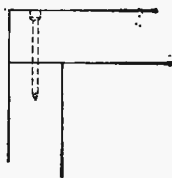

ALTERNATE MITRE JOINT

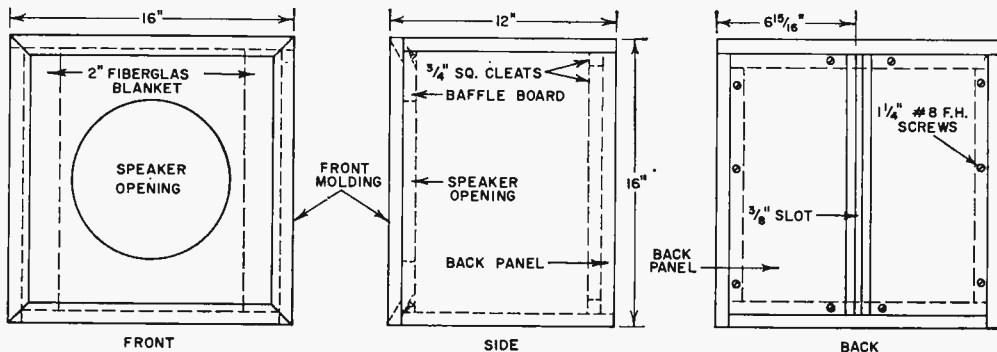
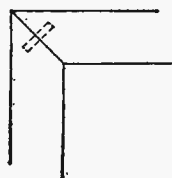

Construction diagram above shows how to fit pieces together, and gives two alternate methods for joining.

The slot in the back operates more as a pressure release vent than a reflex port. It will not give your speaker a bass end if it doesn't already have one—which is why you should use a speaker with a low cone resonance. With such a speaker, you will get a smooth over-all response with a clean bass end that is not tubby or boomy.

### building the enclosure

The construction of the cabinet is simple. There are several different ways of jointing it at the corners. If you have equipment available to cut accurate miters, by all means miter the joints. You get a good-looking, professional-type job that way. Otherwise, use a butt joint. It's a matter of appearance, not performance.

Note that the lengths to which you cut your pieces for the top and bottom are the same no matter which way you do the jointing—namely, 16". However, the lengths of the sides will vary depending on the type of joint you decide to use: miter joint 16"; plain butt, 14½".

First cut the top, bottom, and two side pieces. Then prepare the ends for joining depending on the type of joints you intend to use. Miter all ends for miter joints, or smooth off the ends for a plain butt.

### assembly

Assemble these first four pieces to form the basic box, using glue and finishing nails. Then take your molding and make a frame to fit over the front of the box. Attach it with glue and small finishing nails. This time you have no choice—you have to miter the corners. But mitering molding is easy whereas mitering a whole side might not be quite as simple.

Final step in assembly of speaker enclosure is installation of Fiberglass and "buttoning up" the back.

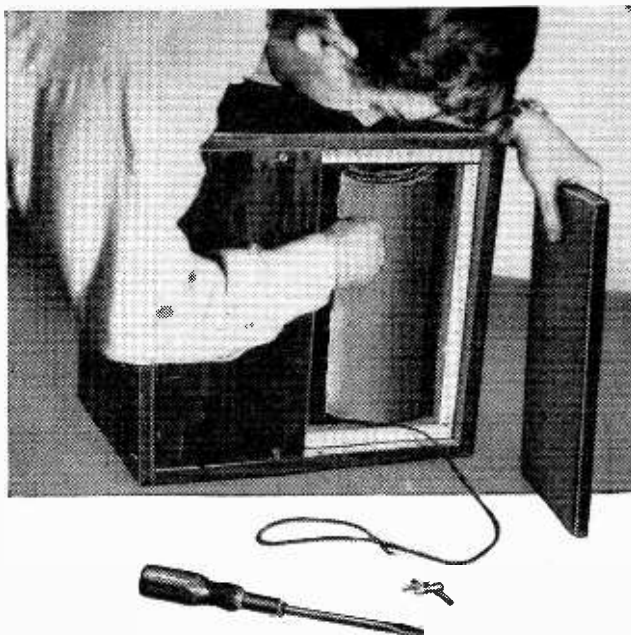

Choose molding to your taste. You will be surprised what a difference it can make in getting this piece to blend well with your furnishings. Be sure the molding overlaps the inside of the box by at least  $\frac{1}{4}$ " so that when you install the speaker mounting board it will have something good and solid to push up against providing a firm airtight seal all around.

### mount the speaker

Now cut the speaker mounting board. Make it just a shade smaller than  $14\frac{1}{2}$ " x  $14\frac{1}{2}$ " on the sides so you won't have to fight to get it in. Cut the speaker opening in the center of the board to the appropriate size for the speaker you plan to use. Most 10" speakers require a hole 9" in diameter; most 8" speakers need a 7" hole. For other size speakers, make the hole slightly smaller than the diameter of the cone.

The next step is to blacken the front of the mounting board and the inside of the speaker hole. Paint or stain will do. This will prevent the speaker from showing up as a dark circle through the grille cloth. After the board is dry, tack or staple the grille cloth to the front of it and trim off the cloth flush with the edges.

Finish the cabinet before you install the mounting board. Otherwise you may slop stain over the cloth. Then mount the board by screwing diagonally through it into the sides.

Be sure the cloth is tight against inside of molding. The material for the  $\frac{3}{4}$ " square cleats for the back can probably be obtained as a stock item in a local lumber yard. Install them with glue and nails. When the glue is set, cut out the two back pieces and try them in place to make sure that you have an exact  $\frac{3}{8}$ " slot open between them. You will see that the panel edges facing the slot are angled at  $30^\circ$ ; don't fret over a degree or two, but keep them close.

Mount your speaker, insert the Fiberglass as shown, screw on the back pieces, and you are finished. Note that the Fiberglass is not stapled, glued or otherwise fastened. Just cut it to the right size, shove it in place, and it will stay by itself. No other means of support is required.

## DOOR-BELL OUTPUT TRANSFORMER

A door-bell transformer makes quite a passable output transformer on some radios. One reason is that the output transformer is essentially a voltage step-down device—and so is the bell transformer. The output transformer is also an impedance-transformer gadget, matching the relatively high impedance of the plate circuit to the very low impedance of the speaker voice coil. While we are not accustomed to thinking of a bell transformer in these terms, it can perform this function. A typical bell transformer has a d.c. resistance of about 400 ohms on the 115-volt side and about 4 ohms on the 6-volt side. This gives remarkably clean results when working out of a 1C5 in older battery portables. It works with varying degrees of success in other sets, depending upon how much distortion is acceptable. The distortion results from the inexact impedance match provided and from the design of the bell transformer, which of course was never meant for audio applications. While the results are certainly not high-fidelity, neither are most small radios. —E.F.C.

## MINIATURE JACK EXTENSION CORD

A tiny extension cord comes in handy wherever miniature jacks and plugs are used with radios or test equipment. Cut a plastic container to a length of about  $\frac{3}{4}$ ", and drill a  $\frac{1}{32}$ " hole for your miniature jack. Punch a small hole through the friction lid to pass the thin shielded cord and solder it to the lugs on the jack. Now mount the jack in the container and put on the lid. Solder a plug to mate with the jack (Lafayette Radio MS-281) to the free end of the twin-cord, and the extension cord is ready to use. —A.T.

## KIT COMPONENT HOLDER

When assembling kits containing a number of resistors and other small components, a great deal of time can be saved by an orderly arrangement of the components. A good way to do this is to press the components to the sticky side of a pressure-sensitive tape. Component values may be written directly on the tape with a ball point pen. The strip of tape is then placed out of the way at the back of the work area where the parts can be easily reached when needed. Capacitors as well as resistors can be arranged on the tape. —L.G.

Never Before Available at this **LOW PRICE!**  
**PRECISION, PORTABLE, TRANSISTOR**

**\$37<sup>50</sup>**

Complete with Microphone-Listening Device, Private Listener, Sample Reel of Tape, DeLuxe Fitted Attache Type, Simulated Leather Carrying Case, Set of Batteries.

**FREE!**  
**Extra 225**  
**ft. Reel of**  
**Recording**  
**Tape!**



## BATTERY OPERATED TAPE RECORDER

**Hi-Quality Reproduction! Weighs only 2 lbs.!**

**PRECISION ENGINEERED**—This amazing new, battery-operated, portable, fully transistorized tape recorder, imported from West Germany, is precision engineered to render the same functions as machines costing five times as much.

**FOR HOME, STUDENTS, BUSINESS**—It will be the center of attraction at home for recording family get-togethers, capturing the magic of speech and song of family and friends—records radio, record and TV shows! Educators, too, agree that students, thru college level, benefit greatly from studying with a tape recorder. Business men can pack it in brief case or bag and take it along on trips to record letters, speeches, instructions, ideas; faithfully records verbal agreements, discussions. Perfect for recording interviews!

**PENNIES TO OPERATE**—The ingenious Tel-Tape records, plays back and erases—even has variable speed controls! Operates on 4 ordinary C-batteries available at any store for pennies. A simple press of a button and you're ready to record. It's so simple, even a child of five can operate it!

**UNCONDITIONALLY GUARANTEED**—A wonderful gift for all—for home, school or business. Unconditionally guaranteed for 90 days against mechanical defects.

**FILNOR PRODUCTS, INC.** Dept. M-60  
101 W. 31 St.  
New York 1, N. Y.

**FILNOR PRODUCTS INC.,**  
Dept. M-60 101 W. 31 St. New York 1, N. Y.

I enclose \$37.50 for the TELTAPE RECORDER, complete with Microphone-Listening Device, Private Listener, Sample Reel of Tape, Deluxe Fitted Attache Type, Simulated Leather Carrying Case, Set of Batteries and Free Extra 225 ft. Reel of Recording Tape.

*Please Print To Avoid Errors And Delay*

Name .....

Address .....

City..... Zone..... State.....

Send C.O.D. Enclosed is \$3.00 deposit. I will pay postman \$..... plus all C.O.D. and shipping charges for the items ordered.

**NOW!**  
at a price  
you can afford!

# MAKE MORE MONEY in TELEVISION RADIO-ELECTRONICS

**BETTER...MORE COMPLETE...LOWER COST...  
WITH NATIONAL SCHOOLS SHOP-METHOD  
HOME TRAINING!**

**BETTER...** Training that is proved and tested in Resident School shops and laboratories, by a School that is the **OLDEST** and **LARGEST** of its kind in the world.

**MORE COMPLETE...** You learn **ALL PHASES** of *Television-Radio-Electronics*.

**LOWER COST...** Other schools make several courses out of the material in our **ONE MASTER COURSE**... and you pay more for less training than you get in our course at **ONE LOW TUITION!**



These  
**two FREE** books will  
show you how!

You get all information  
by mail... You make  
your own decision... at  
home! **NO SALESMAN  
WILL CALL**

## TOP PAY...UNLIMITED OPPORTUNITIES LIFETIME SECURITY CAN BE YOURS!

You are needed in the Television, Radio, and Electronics industry! Trained technicians are in growing demand at excellent pay—in **ALL PHASES**, including Servicing, Manufacturing, Broadcasting and Communications, Automation, Radar, Government Missile Projects.

**NATIONAL SCHOOLS SHOP-METHOD HOME TRAINING**, with newly added lessons and equipment, trains you in your spare time at home, for these unlimited opportunities, including many technical jobs leading to supervisory positions.

**YOU LEARN BY BUILDING EQUIPMENT WITH KITS AND PARTS WE SEND YOU.** Your National Schools course includes thorough *Practical* training—**YOU LEARN BY DOING!** We send you complete standard equipment of professional quality for building various experimental and test units. You advance step by step, perform more than 100 experiments, and you build a complete TV set from the ground up, that is yours to keep! A big, new TV picture tube is included at no extra charge.

**EARN AS YOU LEARN.** We'll show you how to earn extra money right from the start. Many of our students pay for their course—and more—while studying. So can you!

### RESIDENT TRAINING AT LOS ANGELES

If you wish to take your training in our Resident School at Los Angeles, the world's TV capital, start **NOW** in our big, modern Shops, Labs and Radio-TV Studios. Here you work with latest Electronic equipment - - professionally installed - - finest, most complete facilities offered by any school. Expert, friendly instructors. Personal attention. Graduate Employment Service. Help in finding home near school - - and part time job while you learn. Check box in coupon for full information.

**LESSONS AND INSTRUCTION MATERIAL ARE UP-TO-DATE, PRACTICAL, INTERESTING.** Every National Schools Shop-Method lesson is made easy to understand by numerous illustrations and diagrams. All instruction material has been developed and tested in our own Resident School Shops, Laboratories and Studios.

**SEND FOR INFORMATION TODAY**... it can mean the difference between **SUCCESS** and failure for you! Send for your **FREE BOOK** "Your Future in Television-Radio-Electronics" and **FREE Sample Lesson**. Do it **TODAY**, while you are thinking about your future. It doesn't cost you anything to investigate!

### GET THE BENEFITS OF OUR OVER 50 YEARS EXPERIENCE

Approved for  
GI Training



**NATIONAL SCHOOLS**

Los Angeles 37, Calif.

### YOU GET...

- 19 Big Kits—**YOURS TO KEEP!**
- Friendly Instruction and Guidance
- Job Placement Service
- Unlimited Consultation
- Diploma—Recognized by Industry
- **EVERYTHING YOU NEED FOR SUCCESS!**

**SHOP-METHOD HOME TRAINING  
COVERS ALL PHASES OF INDUSTRY**

1. Television, including Color TV
2. Radio AM & FM
3. Electronics for Guided Missiles
4. Sound Recording and Hi-Fidelity
5. FCC License
6. Automation and Computers
7. Radar & Micro-Waves
8. Broadcasting and Communications

## NATIONAL TECHNICAL SCHOOLS

WORLD-WIDE TRAINING SINCE 1895

**MAIL NOW TO**  
**NATIONAL SCHOOLS, Dept R5A-29**  
4000 S. FIGUEROA ST. LOS ANGELES 37, CALIF.  
Rush free TV-Radio "Opportunity" Book and sample lesson. No salesman will call.

NAME \_\_\_\_\_ AGE \_\_\_\_\_

ADDRESS \_\_\_\_\_

CITY \_\_\_\_\_ ZONE \_\_\_\_\_ STATE \_\_\_\_\_

Check if interested **ONLY** in Resident School training at Los Angeles.  
**VETERANS:** Give date of Discharge.



## section ■■■ for your home and darkroom

make an electronic secretary	<b>42</b>
build a conversation piece	<b>45</b>
flash lights with transistors	<b>48</b>
trap those unwanted stations	<b>50</b>
suit your volume with a t-pad	<b>54</b>
battery-operated proximity relay	<b>56</b>
make the kids happy with a clown	<b>59</b>
build the simpla-timer	<b>61</b>
transistorized photoflash	<b>63</b>
build an electric shutter release	<b>69</b>
photographer's light distributor	<b>70</b>
transistors replace wall outlet	<b>72</b>
how to convert transistor set for car	<b>75</b>
squawk with a transihorn	<b>78</b>
go mobile with the "auto-fi"	<b>81</b>
make your own two-set coupler	<b>84</b>



by tracy diers



# make an electronic secretary

How would you like to have a secretary who will answer your phone and take messages at any hour of the day or night but who will demand no pay? Impossible, you say? The miracle of electronics has all but removed the word "impossible" from the dictionary.

There are two types of systems you can build which will do this job for you. The deluxe system requires two tape machines or one tape machine and one disc machine—when a call comes in, it plays a recording of instructions and then switches over to record the message. The simpler type, to be described here, requires only one recorder and anyone who can put together a small amplifier can build it.

Before you put it in service, tell all prospective callers to let the bell ring for 45 seconds. When the phone is picked up by your "secretary," the caller will then have 30 seconds to record his message.

## the amplifier

A 3" x 5" phenolic or perforated composition board may be used as a subchassis. Parts placement is non-critical, but be sure you connect the 1N34A (*CRI*) diode in the correct polarity. Relay *RL1* should also be mounted on this subchassis. The wiring procedure is straight-forward and uncomplicated.

After the amplifier wiring is completed, certain checks should be made. Connect the battery pack with a milliammeter in series with the negative lead.

The instant the connection is made, *RL1* should close for two to three seconds. The current at that time should be about 5 or 6 ma. When *RL1* opens, the meter will read about 0.75 ma.

## parts list

- B1, B2—7½-volt battery (Burgess D5)
- C1—100- $\mu$ fd., 15-volt electrolytic capacitor
- C2—500- $\mu$ fd., 15-volt electrolytic capacitor
- C3—8- $\mu$ fd., 15-volt electrolytic capacitor
- C4—100- $\mu$ fd., 15-volt electrolytic capacitor
- C5—500- $\mu$ fd., 150-volt electrolytic capacitor
- CH1—Modified 16-henry choke (Stancor C-1003)
- CR1—1N34A crystal diode
- J1—Open-circuit phone jack
- R1—2000-ohm, ½-watt resistor
- R2—1000-ohm, ½-watt resistor
- R3—10,000-ohm, ½-watt resistor
- R4—47-ohm, ½-watt resistor
- R5—33,000-ohm, ½-watt resistor
- R6—8700-ohm, ½-watt resistor
- RL1—5000-ohm relay (Potter & Brumfield RS5D)
- RL2—9000-ohm relay (Sigma 11F-9000-G/sil)
- RL3—30-second thermal time delay relay (Amperite 115N030)
- S1—S.p.s.t. toggle switch
- SR1—130-volt, 50-ma. selenium rectifier
- TR1, TR2—CK722 transistor
- 1—Telephone pickup coil
- 1—Solenoid (Guardian Type #12)

## how it works

The telephone bell pickup coil (CH1), a modified 16-henry choke, is placed close to the phone and picks up the "ring" voltage by induction. The induced voltage is sent to the two-stage transistor amplifier and causes relay RL1 to close momentarily at each ring. Each time RL1 closes, it feeds the line current through selenium rectifier SR1, which charges C1 and C2 to a higher and higher voltage.

When the voltage across C2 is high enough, it will close RL2 and keep it closed. RL2's closing connects the line voltage to the tape or wire recorder and to RL3, which is a special 30-second thermal delay relay. The tape machine is running from the time RL2 closes. After 30-seconds time delay, RL3 closes, putting 117 volts a.c. on the handset lifter, and the bell stops ringing.

When the caller hears the receiver lifted, he starts to record his message. (The tape machine audio pickup is one of the inductive pickup types designed for placement under the telephone.) In about 30 seconds, the voltage on C1 and C2 has fallen too low to hold RL2 closed. When RL2 opens, it shuts off the entire mechanism, except for the transistor amplifier—which is ready for the next caller.

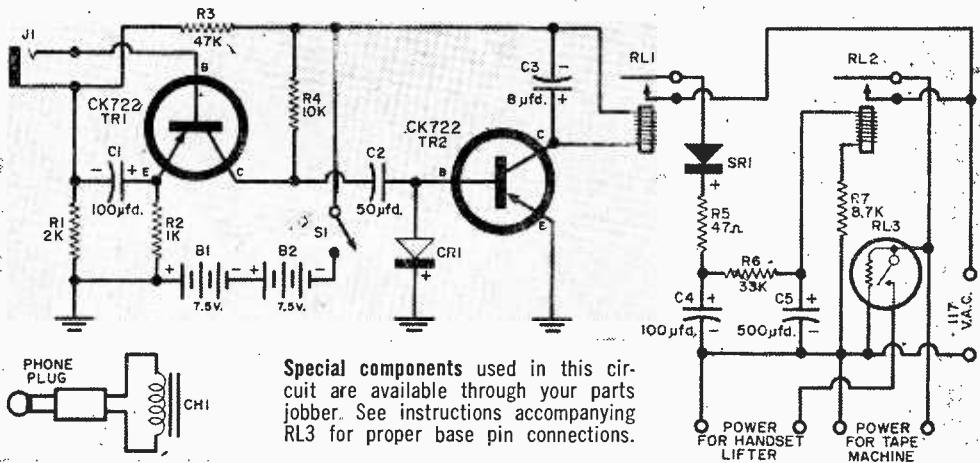

Almost any choke coil will work, but the greater its inductance the more sensitive it will be. To adapt it for pickup service, you must realign the laminations so that they all point in the same direction—forming an "E" with the coil on the center pole.

Connect the pickup coil (CH1) to the amplifier with a 3' to 4' length of lamp cord wire. When you turn on the battery power to the amplifier, RL1 should close momentarily as before.

Have someone call your telephone number and, while the bell is ringing, move CH1 around the sides of the plastic telephone case until you find a spot where RL1 closes instantly each time the bell rings. Plastic tape will hold it in position.

### Assembly details of handset lifter.

See photo on next page for setup.

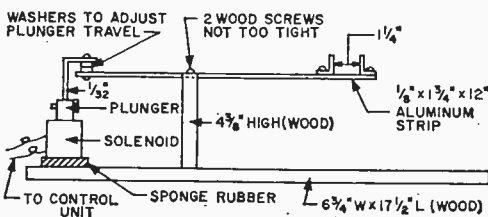

A good chassis size is 10" x 5" x 3", with the transistor subchassis mounted as shown. Four machine screws with ½" sleeves or standoffs will keep the subchassis from making electrical contact to the main chassis. Bring all subchassis connections into the main chassis. The on-off switch (S1) can be mounted in any convenient spot.

Mount a standard phone jack (J1) on the main chassis for plugging in the telephone

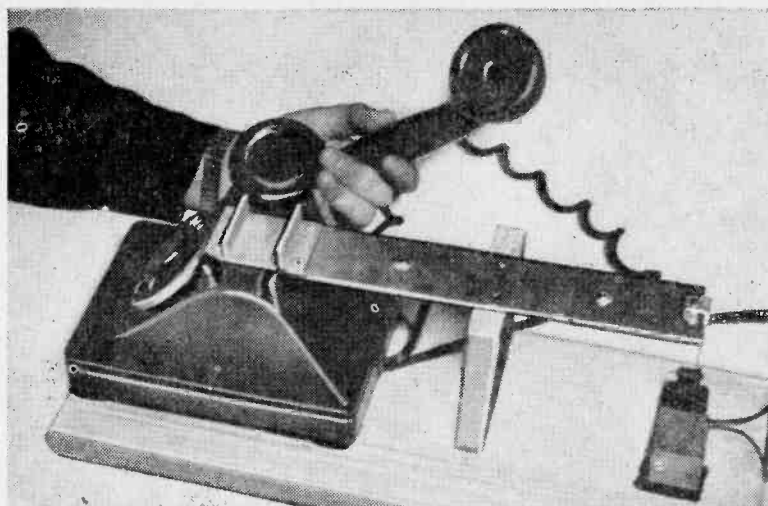

Handset lifter mechanism in place. Voice pickup coil is beneath the base, bell pickup is on the far side.

bell pickup coil. Insulate *J1* from the chassis with insulating shoulder washers. Chassis must *not* be used as a ground for either the transistor amplifier or timing circuit—use insulated terminal lugs as common points and keep the ground of the amplifier separate from the ground of the main control unit.

The thermal delay relay tube (*RL3*) plugs into a standard octal tube socket, and the two 7.5-volt batteries are held in place with a small metal strap as shown. Mount two standard a.c. female receptacles in one side of the chassis for the recorder and the handset lifter—both of these operate on 117 volts a.c.

Timing capacitors *C1* and *C2* must be mounted on low-loss standoffs. If you can't obtain the capacitance needed in a single unit, parallel several low-leakage types.

The solenoid actuator should be adjusted so that the solenoid plunger pulls completely in and lifts the phone handset about half an inch. You can mount the solenoid on a piece of sponge rubber to deaden its hum. While adjusting the lifter, temporarily tape down the telephone button switch.

For the final test, plug the solenoid directly into the 117-volt line. The handset should pop up about half an inch, and when the line voltage is removed, it should drop back in place. Check it to be sure it is working with a minimum of hum or vibration.

The transistor control unit must be located near the telephone to keep the telephone bell pickup coil lead short. The tape machine can be a little further away from the phone.

Plug the tape machine and the handset lifter into their respective a.c. receptacles on the control unit. The inductive speech pickup is placed in the proper spot under the telephone. Preset the tape machine to record, and you are ready for operation.

You may have to experiment to get the correct volume control setting for the tape or wire machine.

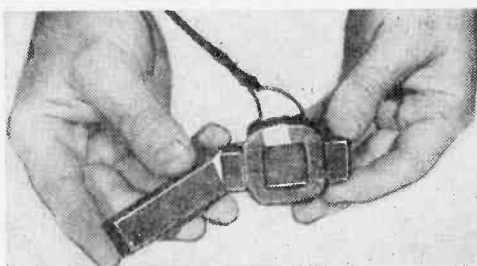

Bell pickup assembly showing the "I" laminations removed.

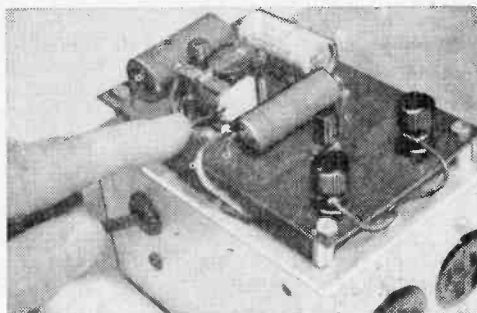

Transistor amplifier subassembly with *RL1* and standoff mounts.



## build a "conversation piece"

*let the whole family listen in when you telephone grandma*

*by joseph w. doherty, K2SOO*

Have you ever made a long-distance telephone call to grandma in New Hampshire, and spent most of the three minutes trying to give each of the kids a turn on the phone? Have you ever sat frustrated, listening to your wife's one-sided conversation with a friend, wondering what was behind the string of "Yes," "No," and "Maybe?"

Fret no more. You can make telephoning a family affair by building the "Conversation Piece," at a cost of about \$6, and never again wonder what your mother-in-law or your friend is saying about you on the other end of the wire.

Basically, this unit consists of a telephone pickup coil ( $L1$ ), available at most supply houses, coupled to a two-stage transistor preamplifier. The output of the preamp is fed directly into the phono input jack of a radio, TV set, or any kind of audio amplifier.

The preamplifier is necessary to build up the low output from the pickup coil to a level comparable to that of the average crystal pickup, in order to drive the tube amplifier. Transistors  $TR1$  and  $TR2$  are 2N107's, which operate from a 3-volt d.c. supply consisting of two penlight cells in series. Total current drain in this case is 0.24 ma., insuring long life without frequent battery changes.

Transistors were chosen because they permit the design of a compact unit with a self-contained power supply and the elimination of interconnecting power cable harness. The result is a box measuring  $4'' \times 4\frac{1}{2}'' \times 3\frac{3}{4}''$ .

Capacitor values are not critical. The limited frequency response of the telephone doesn't dictate the use of expensive miniature electrolytics of large capacitance; the smaller

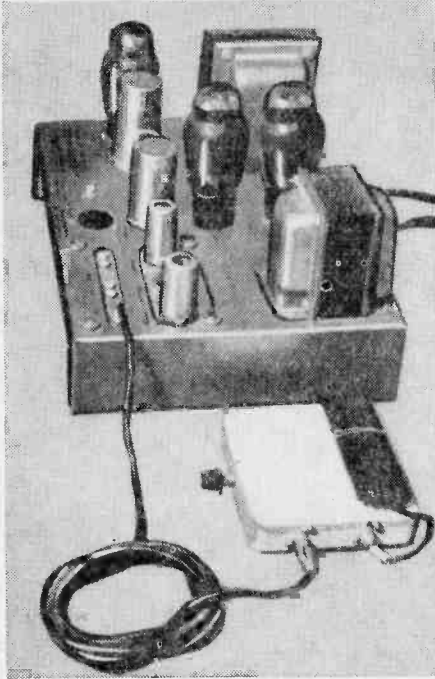

Complete equipment (left) consists of telephone pickup coil, the "Conversation Piece," main amplifier and loudspeaker. The CP could also be fed into the phono jack of a radio receiver or TV set.

values commonly used for interstage coupling in vacuum-tube amplifiers will suffice for the purpose.

Resistor values are fairly critical and were determined after experimenting to provide the maximum gain possible with the transistors. Because the characteristics of the transistors may vary from one unit to another, it is advisable to use potentiometers to determine the optimum values if you have difficulty in obtaining the required gain with the values shown.

Take care to avoid forwarding biasing of the base-collector junction and exceeding the maximum collector current rating. Transistor audio interstage transformers could have been used to advantage in this unit but were

If you build the "Conversation Piece" in a non-conductive box (plastic), join the ground points shown in schematic (right) and in pictorial (below, indicated as ground lugs) with a length of wire.

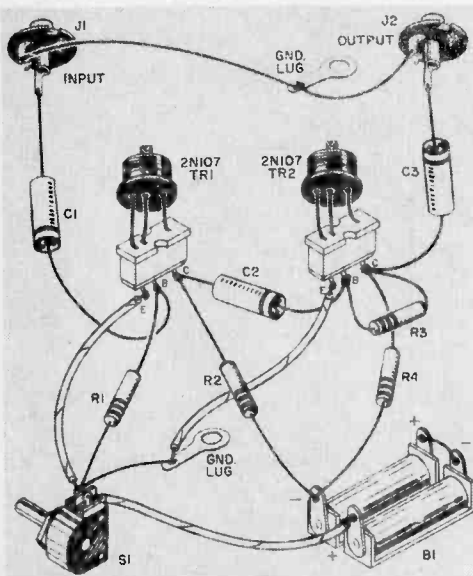
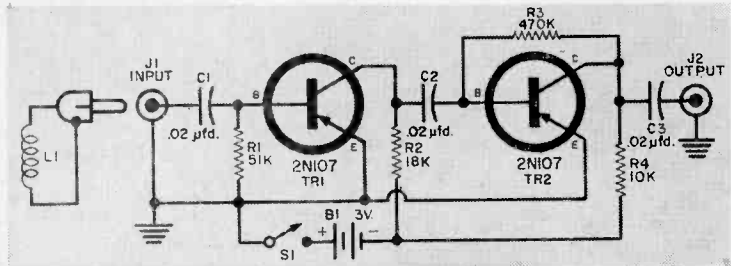

### parts list

- B1—Two 1.5-volt penlight cells
- C1, C2, C3—0.02- $\mu$ fd. capacitor
- J1, J2—Phono pin jack
- L1—Telephone pickup coil
- R1—51,000-ohm, 1/2-watt resistor
- R2—18,000-ohm, 1/2-watt resistor
- R3—470,000-ohm, 1/2-watt resistor
- R4—10,000-ohm, 1/2-watt resistor
- S1—S.p.s.t. on-off switch
- TR1, TR2—2N107 transistor
- 1—Battery holder for the two cells
- 1—Five- or six-lug terminal strip
- 1—4" x 4 1/2" x 3/4" utility box

avoided by the author to keep costs down to minimum.

### installation

Operation of the unit is simple. If your phone is located at or near your radio or hi-fi amplifier, the connections can be made permanently if desired—you just turn on the

amplifier, and the "Conversation Piece" is ready to go.

If your phone is located in another room, say the hall or a bedroom, you'll have to run a line to the amplifier. This should be a shielded cable to prevent hum pickup from house wiring. The line should run from the output jack of the "Conversation Piece" (J2) to the jack on your radio or hi-fi amplifier.

The pickup coil should be placed under the phone base and oriented for the best pickup. No actual connection is made to the telephone at any time. The coil need only be placed next to or under the phone induction coil for satisfactory pickup.

If your loudspeaker and telephone are located in the same room, difficulty might be encountered with acoustic feedback from loudspeaker to phone. This can be cured by either decreasing the gain on the amplifier, by changing the position of the coil, or by rotating the coil slightly. Make sure that the loudspeaker doesn't face the telephone.

### how it works

The telephone contains a coil which provides a transfer of energy between the line and the instrument. Around this coil there is radiated an electromagnetic field which varies in step with your voice. The pickup coil (L1) has an inductance and, therefore, when it is placed in the vicinity of the telephone, the electromagnetic field induces in it a voltage which varies with the voice. This voltage is transferred from the coil to the two-stage RC transistor preamplifier via the input jack (J1), where the signal is increased sufficiently to drive the radio or hi-fi amplifier to which the preamplifier is connected via the output jack (J2).

Acoustic feedback can occur when the output sound waves emanating from the loudspeaker are picked up by the telephone and are transferred back to the input of the device (J1) via the pickup coil. When this sound is fed back to the input with sufficient volume, oscillations will occur, resulting in an echo or ringing effect. At this point the unit is on the verge of oscillation. A slight increase in the magnitude of sound being fed back will cause sustained oscillations—the well-known audio howl. The solution to this problem is to lessen the amount of sound being fed back into the input of the amplifier through careful placement of the microphone (how you hold the telephone) and loudspeaker, or by decreasing the gain of the amplifier.

**BUILD THE BEST!**

build quality money-saving

**knight-kits**

A PRODUCT OF ALLIED RADIO

see them all in

**ALLIED'S 1959  
ELECTRONIC SUPPLY CATALOG**

**free**

**BUILD YOUR OWN!  
IT'S EASY—IT'S FUN—  
SAVE UP TO 50%**

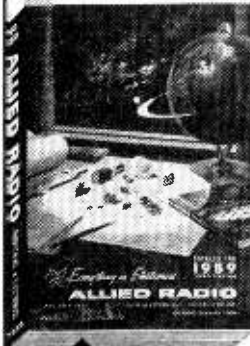

HI-FI  
KITS

**452**  
value-packed  
pages



HAM KITS



HOBBY  
KITS



INSTRUMENT  
KITS

**SAVE on Everything in Electronics**



**WORLD'S LARGEST STOCKS:** Everything for Experimenters, Builders, Amateurs, Servicemen, Engineers, Hi-Fi enthusiasts. Get more for your money in Hi-Fi systems and components, including latest Stereo; save on build-your-own KNIGHT-KITS; recorders and tape; Amateur station equipment; TV tubes, antennas, accessories; test instruments; industrial electronic equipment—plus the world's largest stocks of parts, tubes, transistors, tools and books. Send today for your **FREE 1959 ALLIED Catalog!**

EASY TERMS AVAILABLE

our 38th year

**ALLIED RADIO**

Everything in Electronics at Lowest Prices

send for  
**FREE**  
Catalog

ALLIED RADIO CORP., Dept. 94-9  
100 N. Western Ave., Chicago 80, Ill.

Rush **FREE** 1959 ALLIED 452-Page Catalog.

Name \_\_\_\_\_

Address \_\_\_\_\_

City \_\_\_\_\_ Zone \_\_\_\_\_ State \_\_\_\_\_

# *Flash Light with Transistors*

*use low-current*

*blinker for warning*

*or signaling*

*by r. l. winklepleck*

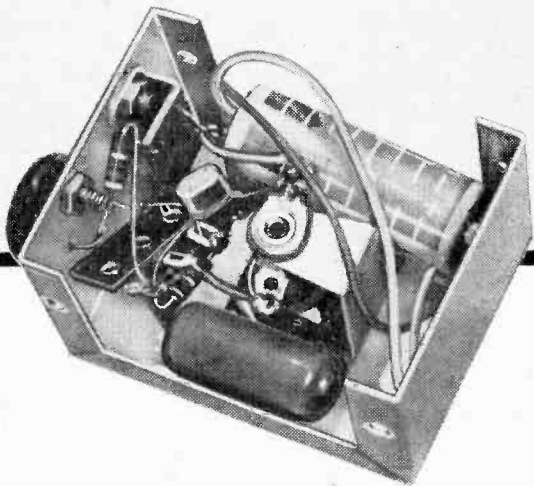
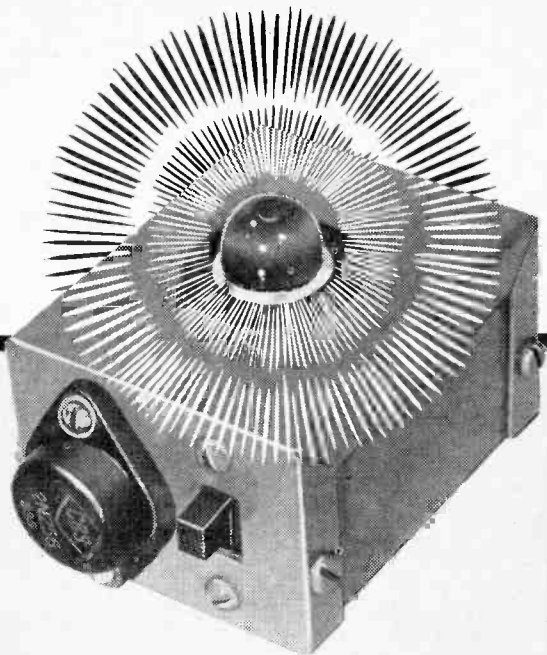

There are many excellent circuits for flashing a light but they require relatively high voltages or currents or both. Neon relaxation oscillators, heated bimetallic strips and various electromechanical systems are commonplace examples. Situations arise, however, when a small flashing light is needed which must operate dependably and economically from a small battery. Here is a good electronic solution for such a problem.

Two transistors, four resistors and a ca-

ELECTRONIC EXPERIMENTER'S HANDBOOK



capacitor provide the pulse which flashes a small incandescent bulb. The power source is a small transistor battery, and the complete flasher assembly can be housed in a 2 1/4" x 2 1/8" x 1 5/8" Minibox. Variations in value of

### parts list

- B1—9-volt battery (Eveready #216)
- C1—100- $\mu$ fd., 12-volt electrolytic capacitor
- PL1—6.3-volt, 150-ma. #40 pilot light
- R1—100,000 ohms
- R2—100 ohms
- R3—2700 ohms
- R4—470 ohms
- S1—S.p.s.t. slide switch
- TR1—2N35 transistor
- I—Minibox (CU-3000)

All resistors  
1/2 watt

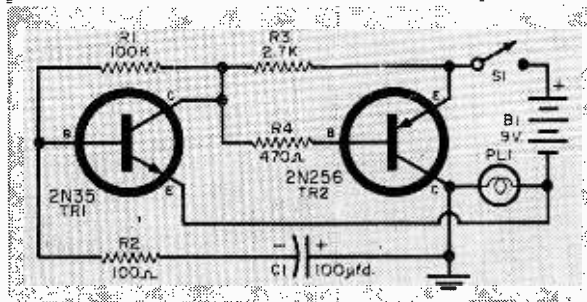

### how it works

When the flasher is first turned on, some time will elapse while a reverse charge is built up in capacitor C1 because of leakage. While this current flows, the voltage drop across resistor R1 holds the base of TR1 biased to cut off. When the flow slows sufficiently, the base of TR1 becomes more positive and it conducts.

The resultant flow of current through the emitter-collector circuit of TR1 biases the base of TR2 (which all this while has been cut off), into conduction. With TR2 conducting, the pilot lamp lights. Simultaneously, the capacitor receives a forward charge, at a rate determined by resistor R2, which continues until the base of TR1 is sufficiently negative to cut it off. This in turn cuts off TR2, the light goes out, and the charge on the capacitor is dissipated at a rate determined primarily by the largest resistor in the discharge path (R2).

As the cycle is repeated, the initial leakage of C1—which slowed the beginning of the sequence—is no longer a factor, and a stable on-off frequency is established and will be maintained.

the capacitor and resistors will change the frequency of the flashes and the duration of the "on" and "off" periods.

The circuit and values shown produce approximately 85 flashes per minute with the "on" period long enough to bring the filament of the bulb to full brilliance. Frequency can be slowed to only a couple of flashes a minute by increasing the capacitance of C1.

Length of the "off" period is largely determined by R1, and R2 determines the length of the "on" period. These all inter-

act, however, and the desired flashing pattern can best be established by trial and error.

Since less than 0.5 ma. is drawn during the "off" period and nearly 150 ma. while the lamp is lit, battery economy is achieved by decreasing the frequency and shortening the "on" period as much as the particular use for which the unit is designed permits.

The 2N35 *n-p-n* transistor, TR1, was selected on the basis of its price and availability. Many others would work as well. The same is true for TR2, although a medium-power type is needed to handle the current drain through the 6.3-volt pilot lamp PL1.

A larger lamp can be used if the need for more light outweighs the disadvantage of increased current consumption. Many other batteries can be employed, ranging from six volts up to the full rating of the bulb, transistors and capacitor.

This flasher circuit offers high efficiency—which means long battery life; its operation is subject to no mechanical limitations; temperature influences its operation only moderately; and it's small and inexpensive.

When you go boating after dark these days, do you need some method of finding your way back to your home dock? This unit on the dock will guide you back. If your neighbor builds one, too, you can avoid confusion by changing bulb color or the flashing pattern.

If you park your car overnight on the street, a small pilot light assembly in one fender and this circuit is the answer. The flashing light is a far more effective warning than one which burns steadily, and it uses less current.

If you replace R1 with a high-value potentiometer, the unit is converted into an adjustable interval timer or metronome. It can be changed from visual to aural by replacing the bulb with a small speaker.

Maybe you're planning to build an electric fence charger. Connect the primary of the pulse transformer in place of the bulb and eliminate all mechanical gadgets usually needed to pulse the circuit.

There are hundreds of other applications.

**TRAP THOSE**

# **UNWANTED**

**STATIONS**

*tune out interfering signals with a wave trap—knock whistles, howls  
or intruding programs dead*

*by louis e. garner, jr.*

Your program is spoiled, and you pick yourself up with a sigh and snap off your receiver. As you take a couple of aspirins to calm that throbbing headache, you quietly resolve to drop the offending set into the trash can when you take out the rubbish . . . or, at the very least, to pester the operator of the offending transmitter—be it the local broadcast station, a commercial or government code station, or a nearby amateur. But after a while, when the ache caused by the unwanted station dies away, you sit down and try to figure out what to do about the situation.

Figure no further. What's been troubling your reception has been, of course, some station beating its own frequency—either as a harmonic or image—against the frequency to which you're tuned, or some close and powerful station overriding it and cross-modulating. For practically peanuts, you can build a wave trap to sidetrack the offending interference.

It's a tuned circuit, adjusted to resonate at the frequency of the interfering signal, and connected to a receiver in such a way as to weaken seriously or eliminate the undesired signal. It is generally used in the antenna circuit.

A wave trap is not a general-purpose "interference filter." Since it is tuned to a specific frequency, it reduces interference only at that frequency. There are two basic types of wave traps: *series-resonant* and *parallel-resonant*. They are shown schematically in Figs. 1 and 2.

### **types of traps**

A series-resonant circuit has a very low impedance at its resonant frequency; in fact, an ideal series-resonant circuit is equivalent to a short circuit. At other than its resonant frequency, it offers appreciable impedance. When connected across the antenna and ground terminals, it acts to short out signals at its resonant frequency, but has little effect on other signals.

A parallel-resonant circuit is just the opposite. It has a very high impedance at its resonant frequency—an "ideal" parallel-resonant circuit would act like an open circuit. At other than its resonant frequency, however, it offers relatively low impedance. When this circuit is connected in series with the antenna lead of a receiver, it forms a voltage divider with the input circuit of the set. Then, at its resonant frequency, the greater portion of the available signal is dropped across the wave trap and relatively little is applied to the receiver. At other than its resonant frequency, since it offers a low impedance to these signals, little or no attenuation occurs and all the signal picked up by the antenna is applied to the receiver.

Since the series-resonant wave trap acts like a short circuit at its resonant frequency, it is most effective when connected across a relatively high impedance circuit. The parallel-resonant wave trap, on the other hand, is most effective when connected in series with the antenna lead of a receiver having a low input impedance.

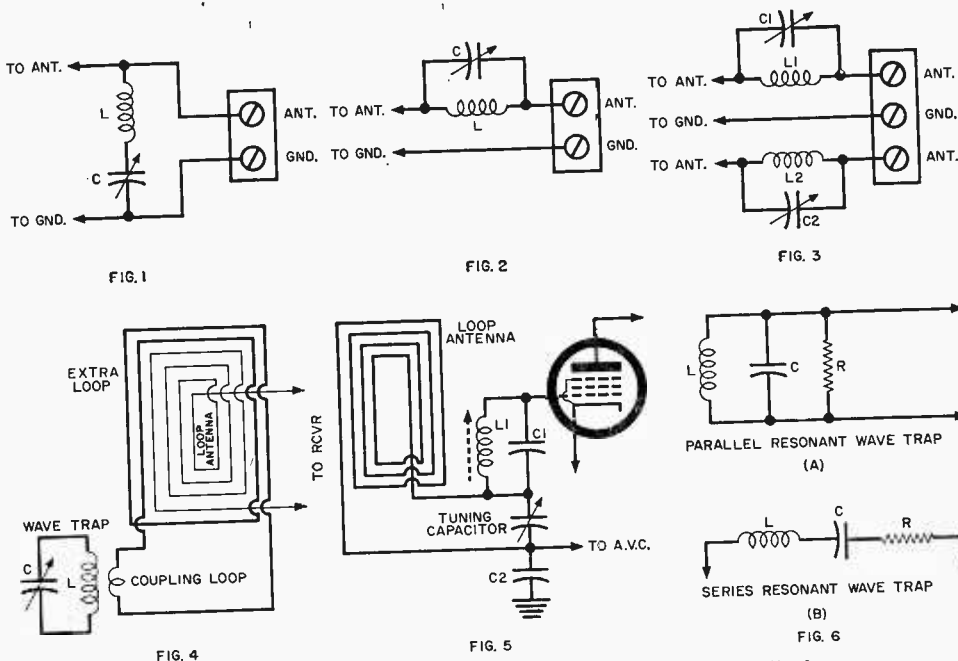

Schematics for the various types of wave traps appear above (Figs. 1-6). A complete explanation of each type of trap and its proper use is given in the text.

Unless you know the input impedance of your receiver, it is best to try both types of traps against an interfering signal, permanently connecting the one which gives the best results. The same coil and capacitor ( $L$  and  $C$ ) combination can be used for assembling either type of wave trap.

### broadcast and short-wave sets

In broadcast and communication receivers, station interference can be caused by a transmitter operating at a frequency close to the desired signal, by strong harmonics of a transmitter operating at a lower frequency, or by a *very strong* nearby transmitter which tends to "blanket" a portion of the band.

In the case of a superhet receiver, interference might be caused by a transmitter operating at the image frequency of the station being received. This is usually above the desired signal by twice the i.f. value. For example, suppose the receiver is tuned to a station at 560 kc. and, further, that the i.f. is 455 kc. The image frequency would be 1470 kc. (twice 455 plus 560), and a transmitter operating at this frequency could cause interference.

Wave traps are effective against all these types of interference.

### the procedure

When use of a wave trap is indicated, the first step is to determine the frequency of the interfering signal, then to choose a coil and capacitor combination which will resonate at this frequency.

The wave trap should be adjustable to permit precise tuning after it is installed. A fixed coil and a variable (trimmer or padder) capacitor can be used, or if preferred, a fixed capacitor and adjustable coil with a movable powdered iron core gives similar results. For the maximum range of adjustment, the coil and capacitor can both be variable.

You can determine the frequency of the interfering signal by listening for the station's call letters and then checking a log book. If the frequency of the interfering station is in the AM broadcast band (550 to 1500 kc.), you can assemble a suitable wave trap from a standard Loopstick antenna coil and a small fixed or variable capacitor (value from 30 to

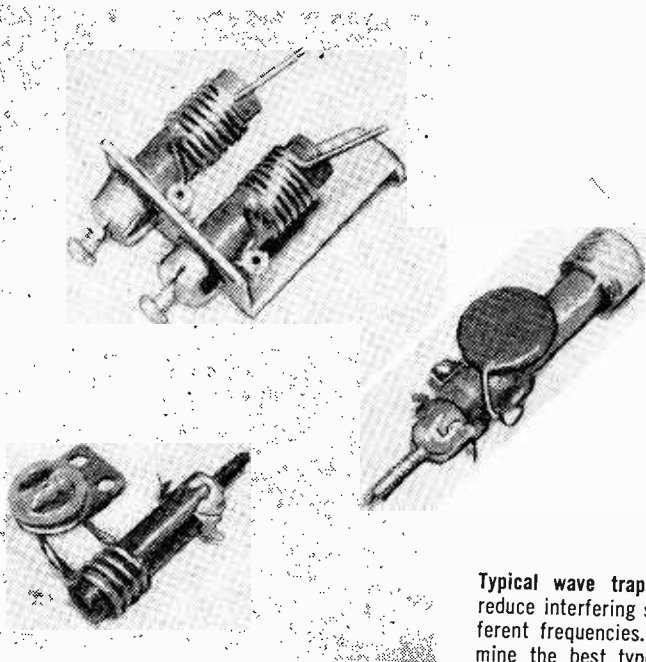

Typical wave traps designed to help reduce interfering signals at widely different frequencies. See text to determine the best type for your problem.

370  $\mu\mu\text{fd.}$ , depending on frequency of interfering station).

If the interfering signal is below the broadcast band, a suitable wave trap can be assembled using the coil from a discarded 455-kc. i.f. transformer or an adjustable r.f. choke shunted with a small ceramic capacitor. If the interfering signal is slightly above the broadcast band, you can use a local oscillator coil. And if the signal falls within the short-wave bands, you can choose a suitable coil from a coil catalog.

With the wave trap assembled, connect it into the receiver circuit temporarily, using one of the arrangements shown in Figs. 1 and 2. Make a preliminary tuning adjustment while the interfering signal is being received. If the interference is rejected adequately, install the wave trap permanently on a small bracket, and give it a final adjustment.

If the first trial does not give adequate rejection, try another arrangement. For example, if the series-resonant wave trap is tried first and proves ineffective, then use the parallel-resonant wave trap.

### doublet antennas

While single long-wire antennas are probably the most popular, and require but a single wave trap, doublet antennas (dipoles) are often used with short-wave receivers. Although a single wave trap in one of the two antenna leads will sometimes give acceptable results, much better rejection of an undesired signal, as well as a better "balance" in the antenna system, can be obtained when two identical wave traps are used, with one connected in each of the two antenna leads.

Such an arrangement is illustrated in Fig. 3, using parallel-resonant wave traps. Of course, dual series-resonant wave traps could be used instead. In this case, one wave trap is connected from each antenna lead to ground.

### loop antennas

Fortunately, loop antennas have an inherent directional characteristic. This minimizes the need for a wave trap, since the antenna can be oriented to reduce the pickup of an interfering signal from a particular direction.

It is difficult to add a conventional wave trap to a loop antenna because the loop is a part of the receiver's input tuned circuit. At other than the wave trap's resonant frequency, it acts like either a coil or a capacitor and may seriously detune the loop. Two

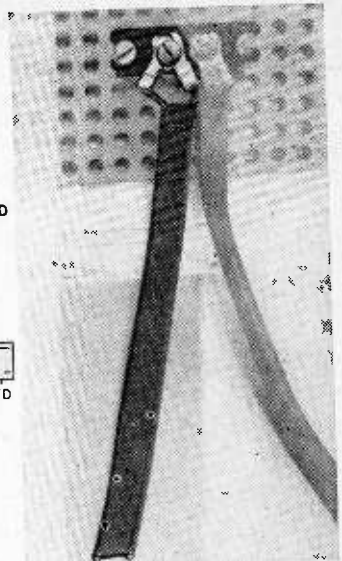
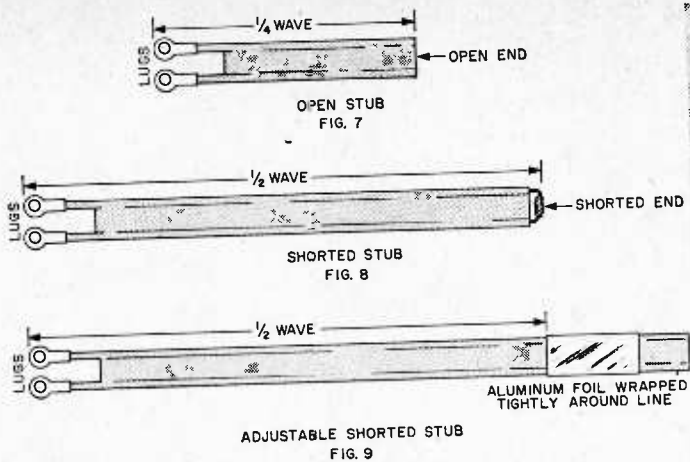

Transmission line stubs are better in the v.h.f. range than LC wave traps. Photo at right shows a typical installation of a line stub on a TV receiver. Diagram above (Figs. 7-9) shows different types of stubs.

techniques which have been used with loop antennas are shown in Figs. 4 and 5.

With the arrangement in Fig. 4, an external wave trap is loosely coupled to the loop antenna by means of a *coupling link*. This consists of 10 or 15 turns around the wave trap's coil ( $L$ ) and one or two turns around the loop antenna. At the wave trap's resonant frequency, it tends to absorb r.f. energy from the loop and thus to cut down on the strength of the interfering signal.

A parallel-resonant wave trap may be used between the loop antenna and the grid of the first tube in the receiver, as in Fig. 5. This system is not too effective because the high input impedance of the tube limits the attenuation which the wave trap can introduce.

### tv receivers

While conventional coil and capacitor combinations may be used to assemble wave traps operating within the TV and FM broadcast bands, the higher frequencies of these bands make it practicable for 300-ohm transmission line stubs to be employed here.

An open length of transmission line acts like a series-resonant circuit at a frequency at which its length is equal to one-fourth the electrical wavelength of the signal at that frequency. Such a line is called a quarter-wave open stub (Fig. 7).

Similarly, a shorted length of transmission line acts like a series-resonant circuit at a frequency at which its length is equal to one-half the electrical wavelength of that frequency, and is called a half-wave shorted stub (Fig. 8).

To determine the approximate length of a quarter-wave stub in inches, divide 2800 by the frequency in megacycles. The transmission line would be cut slightly longer than this, then trimmed to exact length after the stub is connected to the receiver.

For example, suppose the frequency of an interfering signal is 200 mc. Then a quarter-wave open stub which could be used as a wave trap at this frequency would be  $2800/200$ , or 14" long. A shorted half-wave stub would be twice this length, or about 28". In practice, you'd cut a piece of line of about 15" (or 30"), connect it to the receiver, then cut off a little at a time until maximum attenuation of the undesired signal is obtained.

Since a half-wave stub must be shorted at its far end each time its length is adjusted, and since it is twice as long as a quarter-wave stub, the open quarter-wave stub is preferred as a wave trap. However, an adjustable half-wave stub may be made by tightly wrapping a 2" to 4" length of aluminum foil around a length of transmission line (Fig. 9). The aluminum foil introduces a capacitance between the two conductors of the line which acts like an electrical "short" that can be slid back and forth along the line.



## Suit Your Volume with a T-Pad

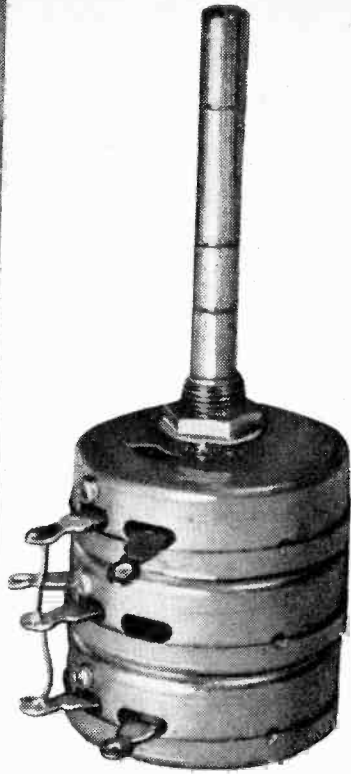

*individually control your  
remote hi-fi speakers*

*by harvey pollack*

Now that multiple-speaker installations have become popular in home hi-fi systems, knowledge of the workings of T-pads is a valuable asset to anyone interested in this type of installation.

Imagine that there are three speakers connected to the output of one hi-fi amplifier and that it is desirable to control the output of each speaker, individually, by means of its own volume control. The natural tendency of the uninitiated builder is to add a potentiometer between the secondary of the output transformer and the voice coil of the speaker, as shown in Fig. 1.

When he does this, he finds that the attempt to cut down the volume from this speaker results in very serious distortion, particularly at low levels. This occurs as a result of the changing impedance presented to the output transformer by the potentiometer variations.

For example, when the wiper of the potentiometer is moved to point *A* of Fig. 1, the impedance seen by the output transformer is composed of the parallel circuit formed by the pot and speaker voice coil; at position *B*, section *AB* of the potentiometer has been placed *in series* with the voice-coil impedance while section *BC* is still in parallel. The

total load impedance, therefore, is vastly different than before, a condition which invites distortion.

A T-pad overcomes this problem by providing attenuation while maintaining a constant impedance to the output transformer and to the speaker. (The L-pad type maintains the impedance match for the output transformer *only*.) In Fig. 2, two identical variable resistors (*a*) are connected in series while a third resistor (*b*) shunts the circuit as indicated. All three are ganged to the same shaft, and as this is rotated, resistances (*a*) rise and fall together while resistance (*b*) changes in the opposite direction.

Suppose that the output transformer secondary winding has an impedance of 10 ohms to match a 10-ohm voice coil. When the T-pad shaft is rotated fully clockwise to the position of maximum volume, the (*a*) resistors might be 0.5 ohm each while the (*b*) resistor is approximately 87 ohms. The two 0.5-ohm resistors in series with the voice coil have practically no effect upon the total circuit impedance, and the 87-ohm parallel resistor has even less, considering that it shunts two 8-ohm windings (transformer secondary and voice coil).

It should be remembered that a comparatively high resistance in parallel with a low resistance produces very little change in the total circuit resistance. In this connection, then, the T-pad produces very little attenuation (about 1 db) and the output signal is just about as loud as it was before the pad was inserted.

If the output of this speaker is now to be reduced to a value so low that it cannot be heard, the shaft of the pad would be rotated fully counterclockwise. At this point, the (*a*) resistors would be 9.8 ohms apiece while the (*b*) resistor has changed to 0.2 ohms. Now there is practically no voltage appearing across the (*b*) resistor since its resistance is so low, all of the power being dissipated in left-hand (*a*) section; as the speaker gets its operating voltage from across the (*b*) resistor, the response of the former would be practically zero. Attenuation would be about 40 db.

In making the above change, however, the impedance presented to the output transformer *has not changed*—it is still about 10 ohms, as shown in Fig. 3. The 9.8-ohm (*a*) resistor and the voice coil shunting the 0.2-ohm (*b*) resistor have very little effect upon the joint resistance of this branch so that, effectively, the upper 9.8-ohm (*a*) section is in series with a 0.2-ohm section for a total impedance of 10 ohms. Thus, a full range of volume control is possible with no distortion from large impedance variations.

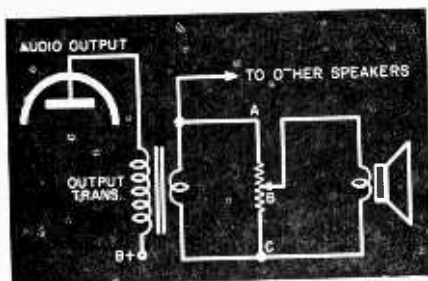

Fig. 1. Pot used as a speaker volume control (not recommended).

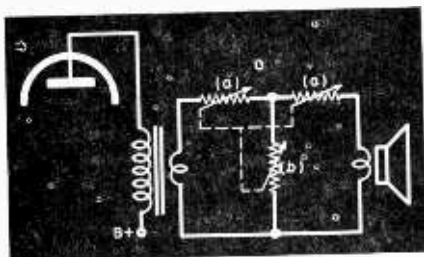

Fig. 2. Theoretical circuit of T-pad as discussed in the text.

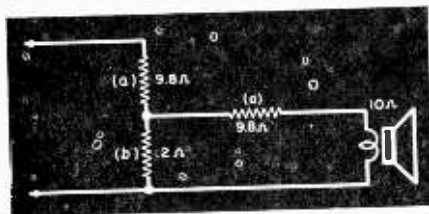
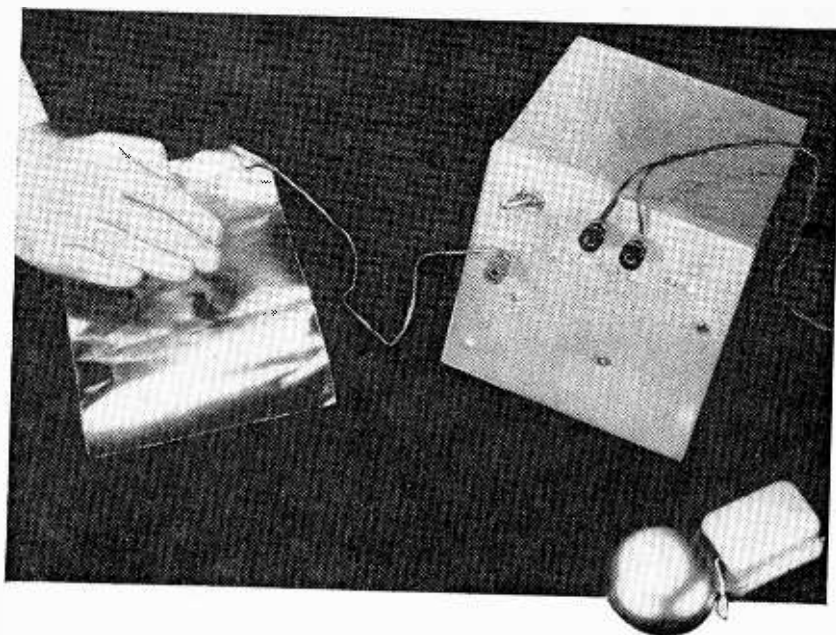

Fig. 3. Circuit of Fig. 2 with T-pad set for maximum attenuation.



# battery-operated proximity relay

*portable detector "senses" people approaching it*

*by rufus p. turner*

The proximity relay is a capacitance-controlled relay that has been well known to gadgeteers and electronic hobbyists for a number of years. Place your hand or body near its "antenna," and the relay closes. Withdraw, and the relay opens.

In some applications, such as intrusion alarms, the proximity relay is sometimes preferred to photoelectric "eyes" because, unlike the photocell, no light source is needed which might betray its presence. Control of store-window moving displays, counting and safety control of heavy-duty machinery are other job opportunities for this device.

Proximity relays described in previous projects have been operated from the a.c. line. This is a definite handicap in portable or emergency applications when line power is not available. The battery-operated proximity relay is ready for instant operation, since no warm-up time is required. Completely battery-operated, our new circuit employs one tube and one transistor. It's self-contained in a metal box, weighs 6½ pounds, and will cost approximately \$22.00.

## **construction and wiring**

The proximity relay is built in a 6" x 6" x 6" aluminum chassis box (LMB No. 973). For convenience, all components are mounted in the top cover of the box and hang downward when the cover is fastened in position. Cut a clearance hole in the bottom cover directly over trimmer capacitor C2 to permit insertion of an alignment tool for adjustment of C2.



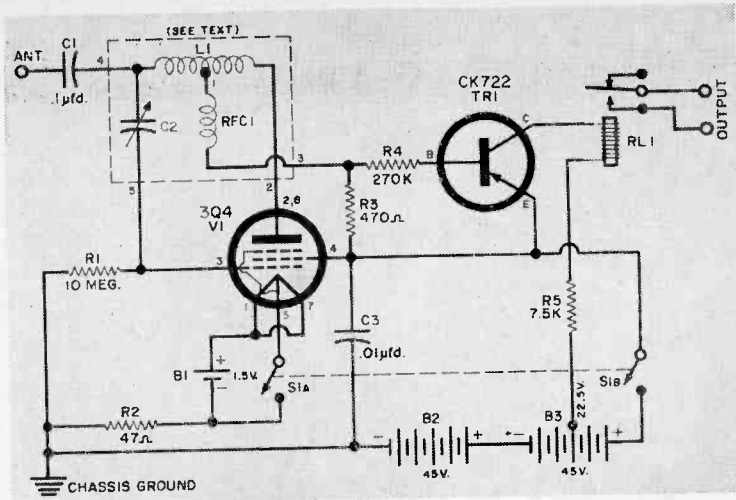

Schematic at left and pictorial below show simplicity of circuitry and wiring. The sensitivity of the relay (RL1) can be increased by adjustment of its pivot screw to loosen the armature spring.

### parts list

B1—1½-volt Size-D cell  
 B2, B3—45-volt B batteries tapped at 22½ volts (Burgess Z30NX)

### how it works

Basically, this device consists of a r.f. oscillator employing a 3Q4, a transistor d.c. amplifier, and a sensitive d.c. relay. The oscillator has little tank capacitance and is sensitive to small capacitance changes such as are caused by approaching nearby objects.

With the antenna connected to the circuit and trimmer capacitor C2 adjusted to bring the circuit just into oscillation, the 3Q4 plate current voltage drop across R3 is small.

When a hand or other conductive object is brought near the pickup antenna, the added capacitance throws the circuit out of oscillation, then the 3Q4 plate current and the voltage across R3 increases. When this higher voltage is applied to the transistor through current-limiting resistor R4, it causes the collector current of the transistor to increase and close relay RL1.

When the hand is withdrawn, the circuit resumes oscillation, the voltage across R3 decreases, the transistor collector current falls to a low value, and the relay opens.

- C1—0.1-μfd., 200-volt metalized tubular capacitor
- C2—Trimmer capacitor in L1 assembly
- C3—0.01-μfd. mica capacitor
- L1—Capacitor-oscillator coil assembly (Miller No. 695)
- R1—10-megohm, ½-watt resistor
- R2—47-ohm, ½-watt resistor
- R3—470-ohm, ½-watt resistor
- R4—270,000-ohm, ½-watt resistor
- R5—7,500-ohm, ½-watt resistor
- RFC1—Radio-frequency choke in L1 assembly
- RL1—8000-ohm d.c. relay (Sigma Type 4-F)
- S1a/S1b—D.p.s.t. toggle switch
- TRI—CK722 transistor
- V1—3Q4 tube
- 1—6" x 6" x 6" aluminum chassis box (LMB No. 973)
- Misc. 7-pin miniature tube socket, battery holder for single 1½-volt Size-D cell, insulated binding posts, terminal strips, etc.

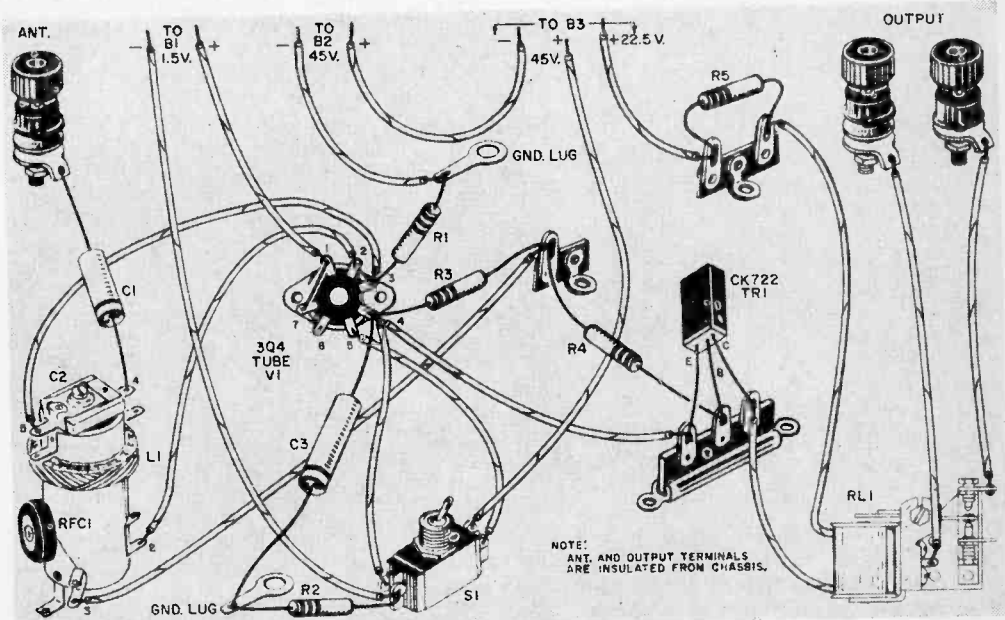

Filament battery *B1* is held by clips mounted on the cover. Batteries *B2* and *B3* are held to the cover by fastening a Bakelite strip to their center (22½-volt) terminals and passing a long 6-32 threaded rod through the center of this strip, between the two batteries and through the cover. The rod is secured by a nut on each end.

Mount the tube socket on a pair of 1"-long screws to keep its contacts clear of the chassis. A couple of strips of plastic tape will prevent accidental shorts. Check your wiring carefully, as a mistake will not only prevent correct operation but may damage components.

The numbers shown on the oscillator-coil assembly (*L1*, *C2*, *RFC1*) are those used by the coil manufacturer in designating the terminals and must be followed in the wiring. Note that terminal 1 of this coil is not connected externally to the circuit. The coil has a pair of right-angle mounting feet which are fastened to the cover with two 6-32 screws and nuts.

Fasten both covers of the box tightly and throw switch *S1* to its "on" position. Insert the alignment screwdriver through the hole in the bottom cover of the box and slowly adjust trimmer *C2*. At one extreme (*C2* at "open" or minimum capacitance), the relay armature should pull in. At the "closed" position of *C2*, the relay should release.

With the circuit oscillating at this setting, touch your finger tip momentarily to the insulated cap of the antenna binding post. The relay should close each time the post is touched and open when your finger is removed. If trimmer *C2* is set to the point at which the circuit just starts to oscillate (the relay just releases), you will find that the sensitivity of the device has increased to such an extent that you can close the relay by bringing your finger tip within a quarter inch of the antenna binding post.

Connect a "pick-up" antenna to the antenna binding post. The actual form, size and shape of the antenna will depend upon the particular use to which the capacitance relay is put and the amount of sensitivity desired. It may be a long wire or a metal plate or object connected by wire to the antenna post.

As a window display, for example, the best pickup device is a 6"-diameter disc of metal foil or thin sheet metal cemented to the inside of the glass. A spectator placing his hand on the outside near the disc can cause lights to flash, electric trains to run.

In burglar alarm applications, the antenna can consist of a length of insulated wire looped several times around the door frame or window frame, or it may be a metal plate or several loops of insulated wire on a window sill or the threshold of a door.

When making the installation, the following steps should be taken. (1) Connect the antenna to be used to the antenna binding post and fasten all parts of the antenna solidly so that no movement will be caused by vibration or jostling. (2) Connect the device to be controlled, and its power supply, to the output binding posts. (3) Throw switch *S1* to its "on" position. (4) Adjust trimmer *C2* as before until the relay closes. (5) Now, turn the trimmer screw in the opposite direction until the relay just opens. By minor adjustments, in one direction or the other, you should be able to set *C2* so that the relay closes when your hand is at the desired distance from the antenna.

Relay closure at six inches from the disc is average. Operation from greater distances may be obtained by more critical adjustment of *C2* to place the circuit just on the edge of oscillation. However, when the adjustment places the circuit too close to the non-oscillating condition, the relay may remain closed when the actuating object has been withdrawn. With proper care, an operator will be able to adjust for maximum sensitivity and still secure dependable relay response.

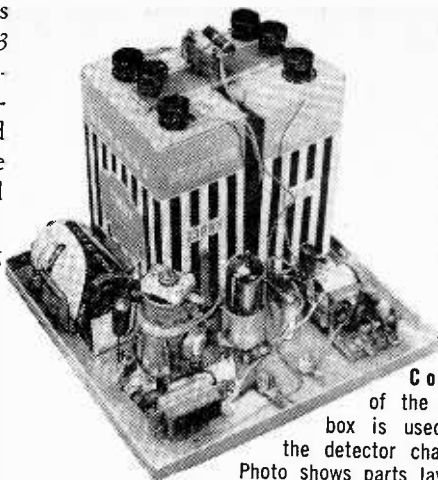

Cover of the LMB box is used as the detector chassis. Photo shows parts layout.

by  
**donald a. smith**

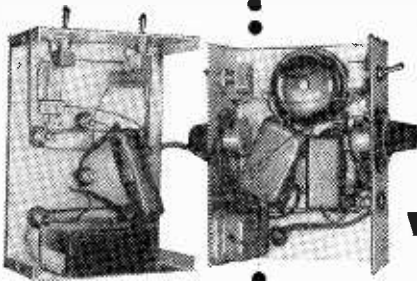
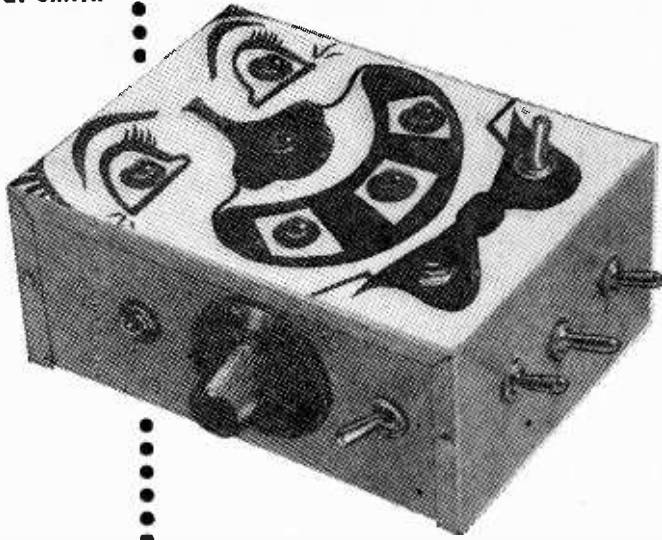

Interior view of the  
"Clown" showing one  
possible parts layout.

## ***Make the Kids Happy with a Clown***

*buzzers, bells and bulbs*

*make an electronic toy for small fry*

Here's a different kind of "baby sitter" to keep the kids amused. It buzzes and rings, has switches to throw, knobs to turn, and lights to go on.

You can use the schematic on the next page as a guide or try other circuit variations. Either way, this clown is a sure-fire toy to present to the kids at Christmas time. It is completely safe for any small child to play with since a 6.3-volt filament transformer is used to power the entire circuit.

Use of a battery supply was considered, but children tend to leave switches on, and the batteries would not last very long. One battery is employed, however. It powers the neon lamp for the clown's "nose." This lamp is used in a relaxation oscillator circuit with a blink rate of two or three a second. As the battery will last five or six months, there is no switch for turning off the "nose."

Switch *S1* is the a.c. "on" switch. The clown's eyes consist of two #47 pilot lamps; *S2* operates one eye, and *S3* the other. Potentiometer *R1* is connected in series with

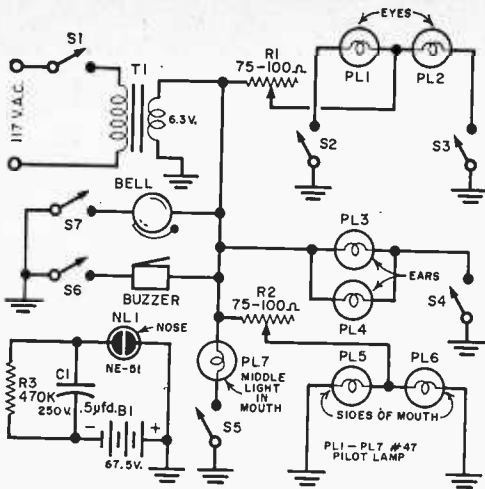

Schematic of "Clown" at left may be followed or hookup used can be based on the contents of your junk box. Potentiometers R1 and R2 should be 2-4 watt wire-wound types to prevent burn out.

varied in brilliance by R2. Switch S5 controls the middle lamp in the mouth. The ears are made up of one #47 lamp each, switched on by S4.

#### cost

Switch S6 is a spring-return toggle type which operates the buzzer. Push-button switch S7 operates the bell. The buzzer and the bell are standard hardware-store items which cost less than a dollar each.

Most of the parts used in this toy may well be in your junk box. In any case, the investment of a little time and very little money will really pay off.

Need something to "keep 'em happy" on a rainy day? Get to work!

them so that it varies the brightness of the eyes.

The mouth is made up of three #47 lamps. Both edges of the mouth can be

## ABRAHAM MARCUS MAKES AMAZING OFFER!

# TRY MY BASIC ELECTRONICS COURSE FOR 1 MONTH *Free!*

### Shortcut to Thousands of \$100-\$150-per-Week Jobs Waiting in Radio, TV, Hi-Fi, Electronics Industry

That's right! ONE MONTH FREE... with this guarantee: If in that time you haven't saved and made plenty of spare-time dollars with your new knowledge, just return the books and pay nothing.

Why do we make this amazing offer? First, because the entire course is written so you can't miss—the same clear, easy-to-understand language that has already made the author's "Elements of Radio" a 1,000,000-copy best-seller. Second, you use only elementary arithmetic. Third, do-it-yourself projects make you a qualified technician fast—able to command high pay, rapid promotion, enjoy a secure future in a zooming industry.

**BEGIN NOW!** You risk nothing by mailing the coupon. Even if you decide to keep the books, you pay on easy terms. Mail the coupon now.

#### WHAT YOU GET IN THIS 3-BOOK COURSE

**BASIC ELECTRICITY.** Basic theory through AC, DC generators, practical applications—circuits—measuring instruments—elements of resistance, inductance, capacitance—thermal, luminous, chemical, magnetic effects—the electron tube—semi-conductors—motors—etc.

**ELEMENTS OF RADIO.** Complete course in fundamentals of radio. Has outsold every other! Requires no previous knowledge of radio, physics, or higher math. Everything you need to know presented in 1-2-3 fashion—including all the latest developments.

#### RADIO PROJECTS.

Build your own receivers! Gives you 10 easy-to-follow projects, including crystal detector receiver—diode detector receiver—regenerative receiver—audio-frequency amplifier—tuned-radio-frequency tuner—AC-DC superheterodyne receiver—Power Supplies—Code Practice Oscillator—etc.

### MAIL COUPON TODAY

PRENTICE-HALL, INC., Dept. 5216-A1  
Englewood Cliffs, New Jersey

Please send me Abraham Marcus' BASIC ELECTRONICS COURSE (3 volumes) for 10 days FREE examination. Within 10 days I will either return it and owe nothing, or send my first payment of \$5.65 plus few cents postage. Then, after I have used the course for a FULL MONTH, if I am not satisfied I may return it and you will refund my first payment. Or I will keep the course and send you two more payments of \$5.65 a month for two months.

Name.....

Address.....

City..... Zone.... State.....

ELECTRONIC EXPERIMENTER'S HANDBOOK

by  
rufus p. turner

External and internal views of the timer are shown below. Note mounting of the large electrolytic capacitor.

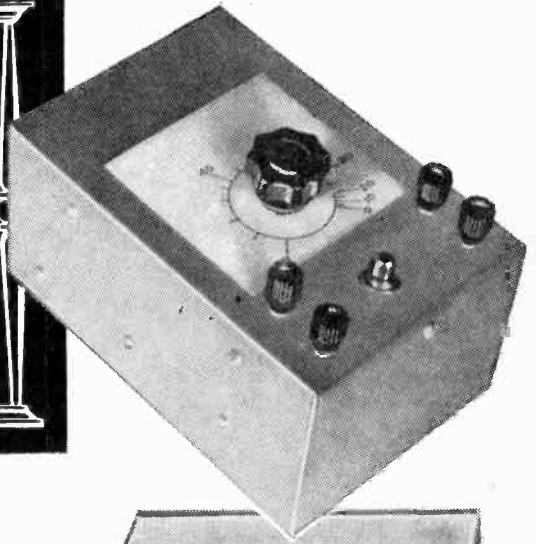
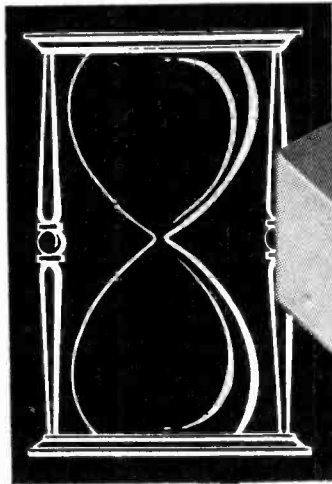

# Build the Simpla-timer

No tubes, transistors or neon bulbs are needed for this compact 5-to-50-second timer. Powered by a small battery, it is independent of power line fluctuations and will switch photocopiers, enlargers and other equipment requiring accurately timed operation.

The device to be controlled by the timer is connected to the *Output* terminals, and the power supply for this device is connected to the *Input* terminals.

Mechanical construction is easy. The timer is built in an aluminum chassis box 6" long, 4" wide, and 3" high.

Mount capacitor *C1* on a side wall of the box with the mounting bracket supplied. If no bracket is supplied with *C1*, both *C1* and

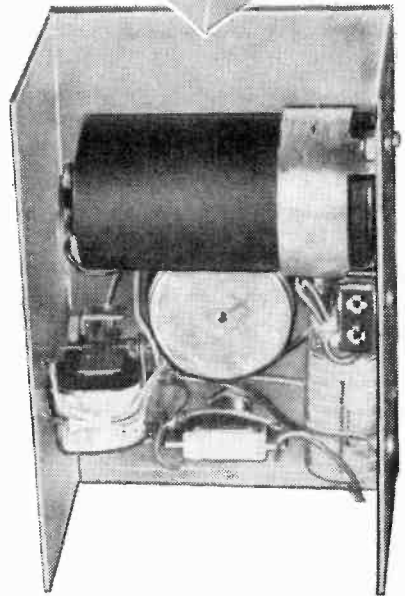

*reliable tubeless timer uses  
minimum of components*

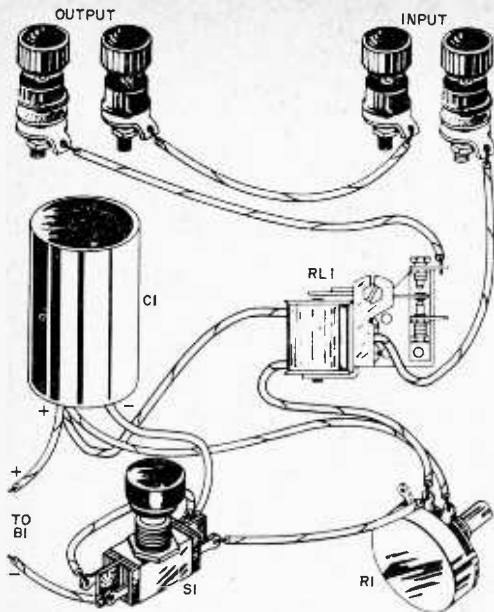

### parts list

- B1—Miniature 9-volt battery (Eveready #226 or equivalent)
- C1—4000- $\mu$ fd., 10-15 volt electrolytic capacitor (Mallory HC-1040 or Sprague TVL-1173)
- R1—50,000-ohm wire-wound potentiometer
- RL1—8000-ohm relay (Sigma Type 4-F)
- S1—Push-button switch (H & H Type 3392 wired as s.p.d.t., or Olson Radio Warehouse #SW-109)
- 1—6"x 4" x 3" aluminum chassis box (LM #141)
- 4—Insulated binding posts
- 1—One-lug insulated terminal strip
- 1—Finger-grip knob with pointer
- 2—Snap-fastener connectors for battery B1

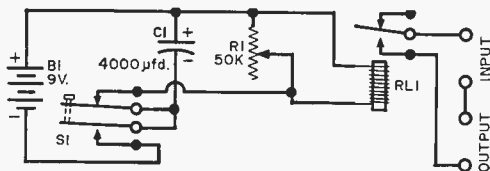

### how it works

Operation is based upon the discharge of a large capacitance through the coil of sensitive d.c. relay RL1. Push-button switch S1 is connected so that its two normally closed contacts keep capacitor C1 connected to the relay coil.

When switch S1 is pressed down, C1 is connected through the two normally open contacts (but now momentarily closed) to the miniature 9-volt battery, B1, and becomes charged. When S1 is released, C1 is reconnected to the relay coil and discharges through it. The discharge current closes RL1 until this current has decreased enough to release the relay.

The time interval during which RL1 is held closed is governed by the setting of the 50,000-ohm control, R1. The scale of R1, therefore, may be calibrated directly in seconds. Parallel connection of R1 and the relay coil resistance causes the nonlinearity of the time interval scale.

battery B1 can be held in place by a short length of flexible, insulated hookup wire secured by a pair of 6-32 screws.

Connections are made to the battery by means of snap fasteners. No on-off switch is needed, since the battery is disconnected when S1 is not pressed.

Draw the time scale on a white card which, after calibration and inking, should be protected with a transparent plastic spray or a coat of clear lacquer.

Wiring is straightforward. No special precautions are necessary, as this is a simple d.c. circuit and no trouble will be experienced from coupling or interaction.

After construction is completed, the timer is calibrated with the aid of a stop watch.

The calibration procedure is simple. Connect a wire jumper temporarily between the *Input* binding posts. Connect an ohmmeter to the *Output* posts. The meter will read zero ohms when relay RL1 is closed, and infinite resistance when it is open. Set R1 near its minimum resistance end.

Press S1 for about four or five seconds. Release it and the stop watch at the same time. The relay will close, as indicated by zero-ohms deflection of the meter. When RL1 opens, as indicated by the meter, check the reading of the stop watch.

If the time interval was not five seconds, readjust R1 by a small amount and repeat

**Simplicity of construction** is evident from pictorial and schematic diagrams of the timer. Input and output terminals should be insulated from chassis. S1 may be a standard s.p.d.t. pushbutton switch, if one is available.

the cycle until the relay remains closed exactly five seconds. Mark this setting as five seconds on the scale of R1.

Repeat the preceding steps to locate the 10-, 15-, 20-, 30-, 45-, and 50-second points and as many intermediate points as possible. Mark the lowlimit setting of R1 as zero. Remove the jumper from the *Input* binding posts, and the ohmmeter from the *Output* posts.

Now remove the scale and ink in the time graduations. Replace the scale. Set R1 to its low limit, line up the pointer to zero on the scale, and the job is complete.

# transistorized photoflash

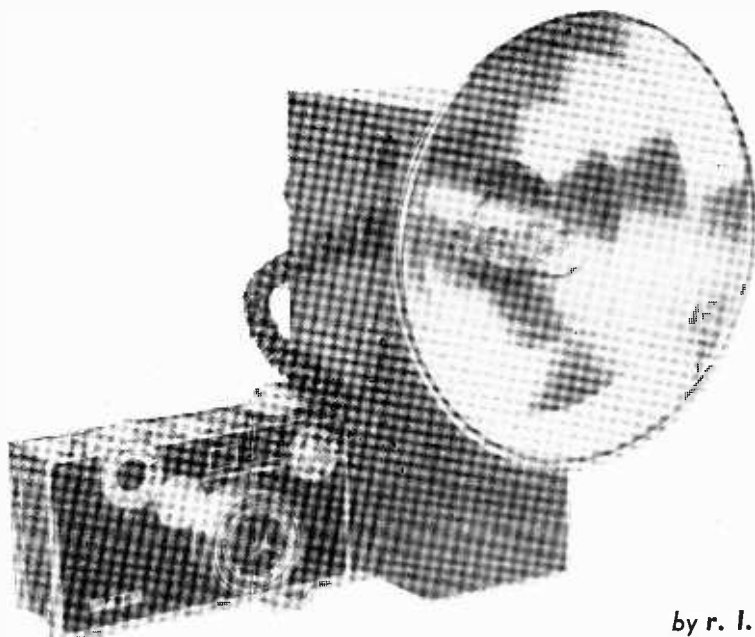

by *r. i. winklepleck*

Electronic photoflash, or speed light as it is sometimes called, is surrounded by so much mystery, hocus-pocus and hocus that many photographers shy away from it without fully appreciating its advantages. Actually, electronic flash is quite simple. There are many variations but, basically, it consists of a power supply providing electrical energy which is stored in one or more large capacitors. A triggering circuit activated by the camera discharges the capacitors through a gas-filled flash tube.

Amount of effective light produced is affected by such factors as the amount of electrical energy consumed, reflector design and efficiency of the circuit and components, including the flash tube. Because the stored supply of electrical energy is about the only factor which can be simply stated and clearly understood, the "watt-second" ratings have been over-emphasized as a yardstick for measuring electronic flash performance. The watt-second rating shows only the amount of electrical energy held in storage. It indicates neither performance nor light output, since these considerations are also profoundly affected by a number of other factors apart from the efficiency of the circuit. Other points to be considered are the size and weight of the outfit, the frequency with which it can be flashed, whether it operates from batteries or an external power source, and whether it's a single unit or two separate units with the power supply carried by a shoulder strap and the flash head mounted on the camera.

No matter if we're building or buying, we can't usually have everything exactly as we'd like it. The electronic photoflash outfit described here is a good and comparatively inex-



Photo above shows battery compartment with batteries installed. Schematic is shown below.

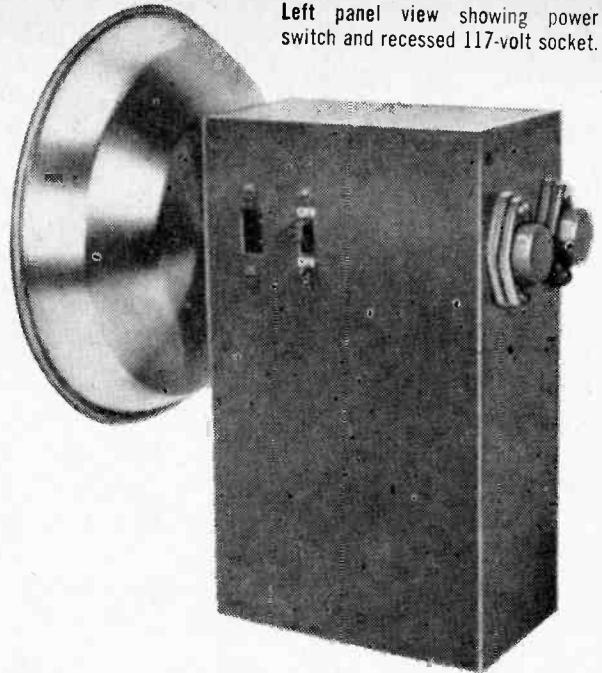

Left panel view showing power switch and recessed 117-volt socket.

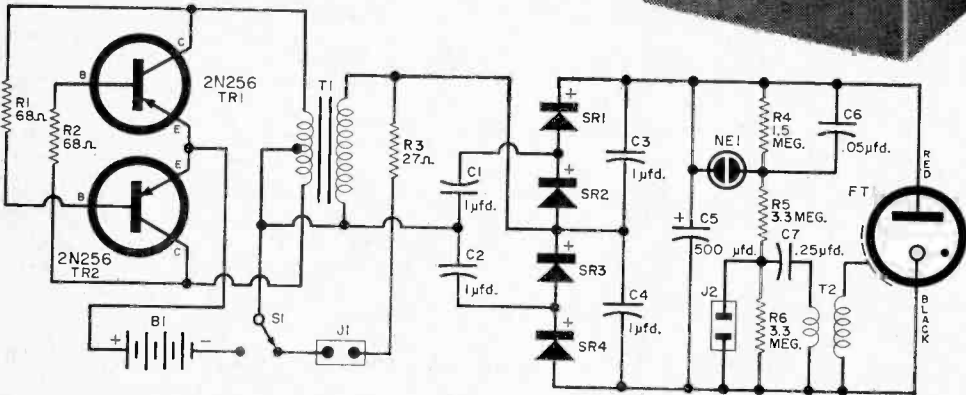

pensive compromise. It operates from either house current or from four inexpensive size D flashlight cells, so battery cost is trifling. It's a single unit, easy to build, rugged and dependable in operation. The photoflash tube is mounted in neoprene under a glass dome to protect it from injury.

### construction

To design in all of these features, it was necessary to accept a bit more size and weight than is considered ideal— $2\frac{3}{4}'' \times 4\frac{1}{2}'' \times 7\frac{3}{4}''$ , and  $4\frac{1}{2}$  pounds with batteries. The housing can be constructed of .064" aluminum sheet with heavier gauge (.125") in the base plate to which the mounting bracket is attached. It is assembled by using self-tapping sheet metal screws to hold aluminum rods or angles as cleats.

Components are mounted on each of the side panels and prewired before assembly of the cabinet. Power transformer, transistors (mounted externally) and resistors of the oscillator, and the battery terminals are on the back panel. The batteries are a snug fit between the back panel and the main storage capacitor.

A removable section in the bottom of the case offers access to the batteries. The lower battery contact, an aluminum strip, is glued to a strip of plastic to insulate it from the



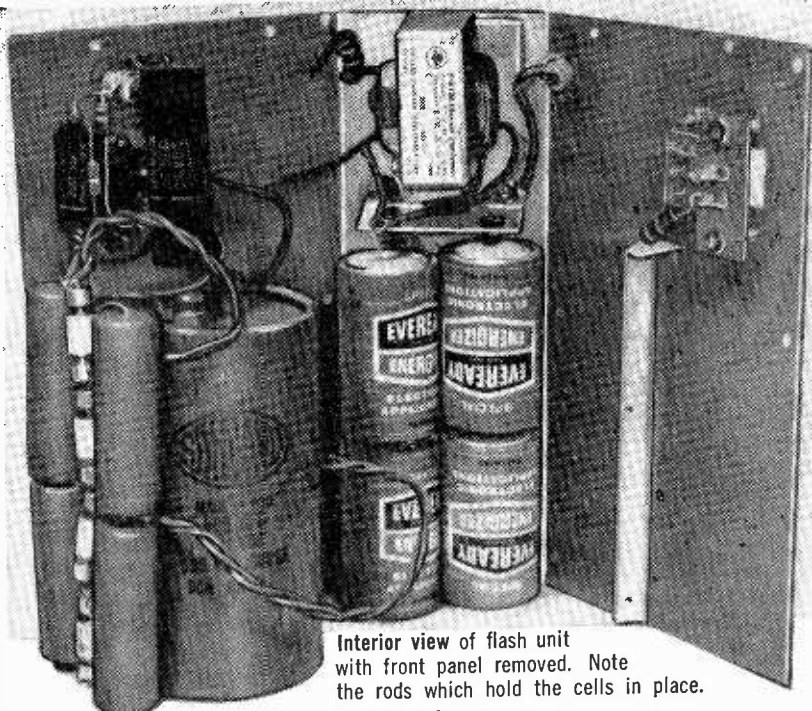

Interior view of flash unit with front panel removed. Note the rods which hold the cells in place.

case, and this is glued to the inside surface of the battery access door plate.

The transistors must be mounted on  $\frac{3}{16}$ " composition with the mounting screws insulated from the case with composition shoulder washers. A rather thick plastic should be used between transistors and case since with thinner material an electrostatic voltage may develop in the case.

No part of the circuit is electrically connected to the case since most camera flash synchronization contacts have one side grounded to the camera body. By keeping the case isolated, there is no need for a polarized flash cord connection.

### wiring

The left panel of the case has mounted on it the s.p.d.t. switch (*S1*) and a recessed TV-type a.c. connection, (*J1*). An ordinary TV cheater cord is used when the flash is operated on house current and the switch is wired so that the a.c. input is in the circuit only when the batteries are off.

On the right-hand panel is an ordinary a.c. outlet (*J2*) into which the flash cord from the camera is plugged, the neon charge-indicating lamp (*NE1*) mounted in a  $\frac{5}{8}$ " rubber grommet, and a 4-point tie strip. Tape the tiny trigger transformer (*T2*) to the tie strip. All of the components shown in the schematic between the storage capacitor (*C5*) and the flash tube (*FT1*) can be mounted on this panel and wired before it is attached to the case.

### parts list

- B1—Four 1.5-volt standard size "D" dry cells
- C1, C2, C3—1.0- $\mu$ fd., 400-volt tubular capacitor
- C5—500- $\mu$ fd., 450-volt electrolytic capacitor (Sangamo DCM or equivalent)
- C6—0.05- $\mu$ fd., 200-volt tubular capacitor
- C7—0.25- $\mu$ fd., 400-volt tubular capacitor
- FT1—Flash tube and reflector combination (Amglo HD-2AR; available from Amglo Corp., 2037 W. Division St., Chicago, Ill.)
- J1—TV-type a.c. input receptacle
- J2—Rectangular a.c. outlet (for camera sync connection)
- NE1—NE-51 neon lamp
- R1, R2—68-ohm, 1-watt resistor
- R3—27-ohm, 1-watt resistor
- R4—1.5-megohm,  $\frac{1}{2}$ -watt resistor
- R5, R6—3.3-megohm,  $\frac{1}{2}$ -watt resistor
- S1—S.p.d.t. slide switch
- SR1, SR2, SR3, SR4—Silicon rectifier (Sarkes Tarzian M150)
- T1—Modified 6.3-volt filament transformer (Stancor P6134—see text)
- T2—Ignition coil (Amglo ST-25)
- TR1, TR2—2N256 power transistor (CBS)

**A Money-Saving Offer for the Readers of the  
ELECTRONIC EXPERIMENTER'S HANDBOOK**

## Accept the next 6 months of **POPULAR ELECTRONICS FREE**

**as part of an Introductory,  
Reduced-Rate Subscription**

### **Step-by-Step Plans for Building Over 270 New Electronic Devices**

If you like to take a set of diagrams and photos...a paragraph or two of clear directions...some simple tools...and build a practical, exciting electronic project, then this offer is for you.

The next year and a half of *Popular Electronics* will bring you more than 270 devices—explained in simple A-B-C fashion, with exclusive “pictorial diagrams” that guide you each step of the way. Experts who have built the devices themselves will show you how to build or assemble hi-fi equipment...money-saving test equipment...tape recording gear...electronic games...low-cost photo units...radio and audio apparatus...solar powered and transistorized rigs...and much more.

The first few issues of your subscription will include such projects as...

- Pocket FM Receiver—needs no antenna!**
- Child-Proof Record Player—no external power!**
- 8-sided Binary Dice Game**
- 2-Transistor T.R.F. Radio**
- 4-Channel, Hi-Fi Transistor Mixer**
- Crystal-Control Transistor Signal Generator**

**SPECIAL  
INTRODUCTORY OFFER**

**18 months of  
POPULAR ELECTRONICS  
only \$3.85**

Regularly, 12 months of *Popular Electronics* costs \$4. But by mailing the card on the opposite page, you'll receive 18 project-packed issues for less than the regular price of 12—actually giving you 6 EXTRA ISSUES AT NO EXTRA COST!

Subscribe now on this money-saving offer to the world's best selling magazine for electronic hobbyists and experimenters. Use the handy card to enter your order today.

**ZIFF-DAVIS  
PUBLISHING COMPANY**



434 S. Wabash Ave.,  
Chicago 5, Illinois

ELECTRONIC EXPERIMENTER'S HANDBOOK

**This Certificate  
Entitles You to The Next  
18 issues of  
POPULAR ELECTRONICS  
for only \$3.85**

**An Offer which Gives You  
the Equivalent of  
6 ISSUES FREE!**

Payment enclosed. (*Save us billing ex-  
penses and we'll add two extra issues  
FREE, making 20 in all for only \$3.85!*)

I'll pay when billed. \_\_\_\_\_  
initial here

EEH-59

NAME \_\_\_\_\_  
please print

ADDRESS \_\_\_\_\_

CITY \_\_\_\_\_ ZONE \_\_\_\_\_ STATE \_\_\_\_\_

Additional postage for addresses not in U.S. or  
Canada; 75¢ for Pan American countries; \$1.50 for  
all other foreign.

**Mail Now—No Postage Needed**

**BUSINESS REPLY CARD**

NO POSTAGE NECESSARY IF MAILED IN U. S. A.

Postage will be Paid by

**POPULAR  
ELECTRONICS**

434 SOUTH WABASH AVENUE  
CHICAGO 5, ILLINOIS

**FIRST CLASS**

Permit No. 3365

CHICAGO 1, ILL.

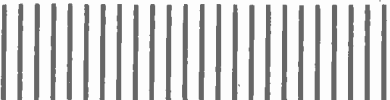

The flash tube and its reflector are mounted on the front panel, using the two bolts provided. Note that the red lead goes to the positive terminal of *C5*, the black lead to negative, and the white lead to *T2*. This leaves only the four silicon rectifiers and the four capacitors (*C1*, *C2*, *C3* and *C4*) of the voltage quadrupler. They also are prewired, using a physical layout which corresponds with the placement shown in the schematic. Considerable space is saved by using pigtails on the rectifiers instead of mountings clips.

The quadrupler is wrapped in plastic and the unit placed against the front panel when the case is assembled. It's held in place with the storage capacitor which is kept in position with two shaped aluminum rods fastened to the side panels.

Assemble the front, rear and right side panels of the case, put the voltage quadrupler and storage capacitor in position, and complete most of the interconnecting wiring. Fasten the left panel in place and wire the switch and a.c. input from above. The top and bottom of the case are then fastened in place to complete the assembly.

A  $\frac{1}{4}$ " tapped hole in the heavy bottom plate is used to attach the camera mounting bracket. The battery access panel is held in place with one screw. Mark the battery polarity on the side of the opening to reduce the possibility of inserting the batteries incorrectly. The photo below shows details of the construction. If desired, the battery trap door can be hinged. The plate that is mounted on the door and which contacts the positive and negative terminals of the batteries *must* be insulated from the door itself. It may be glued to a piece of plastic which, in turn, is glued to the door panel.

### modifications

The only component which requires modification is the power supply transformer (*T1*). Its frame and laminations are taken apart and the entire center-tapped 6.3-volt winding removed. Using only 20 feet of this wire, rewind the secondary, taking off a tap at its mid-point, and re-assemble. This rather simple operation is necessary to provide sufficient voltage for satisfactory operation as the battery output drops with use.

The layout shown is not offered as the final answer. The unit could probably be made smaller and with a different shape. Some builders might like to have a two-unit flash outfit with the power and storage components carried in an over-the-shoulder case and the rest of the components mounted with the flash tube and reflector on the camera. Anglo offers a back cover for the reflector for such an installation.

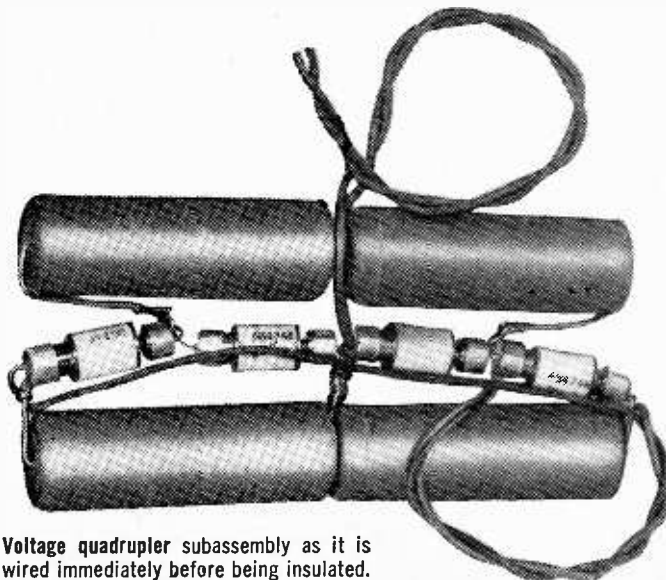

Voltage quadrupler subassembly as it is wired immediately before being insulated.

## how it works

The four D cells operate a 120-cycle, square-wave transistor oscillator using a pair of the new, low-priced power transistors. This method of producing a.c. or interrupted d.c. is several times more efficient than the use of a vibrator.

This a.c. voltage from the oscillator is fed into the modified low-voltage winding of a filament transformer and is boosted to approximately a.c. line voltage. (At this point line voltage is applied when the unit is powered from the line.) A voltage quadrupler using silicon rectifiers boosts the 120 volts up to about 500 volts, which is then supplied to the special storage capacitor (C5).

The flash tube is connected directly to C5 but it will not fire spontaneously. The "trigger" circuit which fires the flash tube consists of three resistors R4, R5, R6, in a voltage-divider network. Resistor R4, shunted by capacitor C6, operates neon lamp NE1 as a relaxation oscillator when the charge on C5 reaches approximately 375 volts. R6 is shunted by capacitor C7 and the primary of the trigger or ignition coil T2 in series.

While C5 is charged, C7 is also charged by the amount of the voltage drop across R6. When the flash contacts on the camera close, they short R6, and C7 is discharged through the trigger transformer primary. This induces pulses of several thousand volts in the secondary which ionize the gas in the flash tube.

The "breakdown" of the tube permits capacitor C5 to discharge through it. This produces a brilliant flash of light having a duration of less than one-thousandth of a second and intensity of nearly thirty million lumens.

## exposure guide

Correct exposure can be determined best by experiment with the camera and film you customarily use. Set up your equipment for average conditions and take a series of pictures varying only the lens aperture. The aperture which gives the best film exposure, multiplied by the flash gun-to-subject distance, gives the correct flash guide number.

The peak light output far exceeds that of most flash bulbs, but it is of such short duration that somewhat longer development will be necessary.

No color correction is usually considered necessary with daylight color film. However, if the results are just a bit blue by your standards, a Wratten 81 or 81-A filter will warm the pictures nicely.

For black-and-white film having a daylight speed of 200, you might start your testing with a flash guide number of 200. Greater speed is possible with over-development, but this practice is falling out of favor.

Film ratings are not necessarily an accurate indication of electronic flash speed. Because of what is known as "reciprocity failure," some of the fastest films are less sensitive to the brief burst of light from electronic flash than some of the slower rated films. Remember that shutter speed has no effect on exposure since the light duration is less than one millisecond. However, if a slow shutter speed is used, other lighting in the room will upset the results.

When the flash contacts are closed, the flash of light takes place almost instantaneously. Thus, the camera shutter must be synchronized at "X" or "zero" delay. Accuracy of synchronization can be checked by firing at a light-colored wall and looking through the back of the camera with the lens aperture wide open.

With perfect synchronization, the shutter will be wide open; and with partial synchronization, the leaves of the shutter will be visible and frozen to immobility by the short duration of the flash. If the shutter needs adjustment, this is best left to a specialist.

Compared to conventional flash bulbs, the electronic flash produces softer effects.

If such an arrangement is followed, the builder may wish to use six 1.5-volt cells. This would eliminate the need to rewind the transformer.

In any event, please keep in mind at all times that *the fully charged storage capacitor can give you a powerful and dangerous shock*. Treat it with the respect it deserves. Even partially charged, it offers a nasty surprise for the unwary. During trials of the unit, discharge the capacitor before working on any part of the circuit by shorting it with a 25-watt resistor of several hundred ohms. Don't use a screwdriver. If this is your first high-voltage project, follow the rule the old-timers use; keep one hand in your pocket when working on it.

When the unit is assembled and the wiring completed and double-checked, it is best to try it out the first time with external a.c. power. This is suggested since an electrolytic capacitor, when new or unused for a time, is "unformed."

When the unit is first turned on, the huge storage capacitor (C5) will have a high current leakage. The batteries can "reform" it, but only by nearly exhausting themselves.

Neon lamp NE1 starts flashing when the charge in the storage capacitor reaches approximately 375 volts. From this point on, C5 charges very slowly and will require several minutes to reach 450 volts on a.c. or with fresh batteries. The difference in light output between a 375-volt and 450-volt charge would require only a one-half stop exposure correction.

In operation, the external a.c. power source will require 15 to 25 seconds recycling time between flashes to charge the capacitor. Fresh batteries will require about 45 seconds.

Naturally, the number of flashes possible from a set of batteries is variable; but it should be possible, under reasonable use, to get at least 50—probably many more—flashes from one set. Since this outfit draws approximately one ampere, it's a good idea to turn it off if you expect to wait a while between pictures.

Slight errors in exposure are not as serious as with regular flash bulbs and the depth of lighting is somewhat greater. You'll undoubtedly find yourself taking many more flash shots than ever before; but your picture quality will probably be better.

# Build an Electric Shutter Release

There comes a time in every photographer's life when he'd give anything to have a remote electric shutter release. This is especially true in taking snaps of children or during nature shots—when the idea is to get as far away as possible from the subject.

Here is an inexpensive tripper that you can put together in a few hours. It's intended for cameras with a body release button. As the frame should be built to fit the camera, dimensions are not given.

The framework is made of  $\frac{3}{4}$ " x  $\frac{1}{4}$ " Reynold's aluminum strips. A clamp to fit the camera is formed by strips *A*, *B* and *C*. Strip *D* is mounted at right angles to *B*. All are held by  $\frac{1}{8}$ " screws in tapped holes. One strip (*B*) has a hole drilled to receive the release button. The opposite strip (*C*) clears the camera by  $\frac{1}{4}$ " to allow the frame to slip over the release. Drill and tap it to take the knurled screw which holds the assembly in place. Shim with rubber to make it tight and prevent marring the camera.

Almost any relay can be adapted to operate the release. In this case a 6-volt d.c. type was used, mounted as shown. Note that the armature should move freely. The spring (*E*) is made of two lengths of stiff clock spring, with the end of the lower one heated, then bent around the upper. To it is fastened a stud (*F*) to depress the camera release when the spring snaps. The spring is clamped beneath piece *G*.

The movable support for the free end of the spring must be high enough to let the shutter reset when the spring is raised. This support is rectangular and consists of two brass strips spaced by two heavy wires. The bottom wire fits loosely through a hole drilled in strip *B*. A similar wire at the top supports the end of the spring. Backstop *H* is made of wire and soldered to the side of the support frame, at such an angle that the support is slightly off perpendicular, toward the base of the spring, but not so far that the solenoid won't be able to pull it.

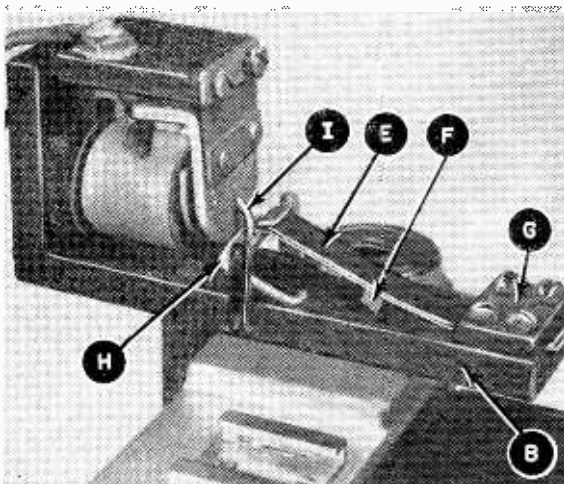
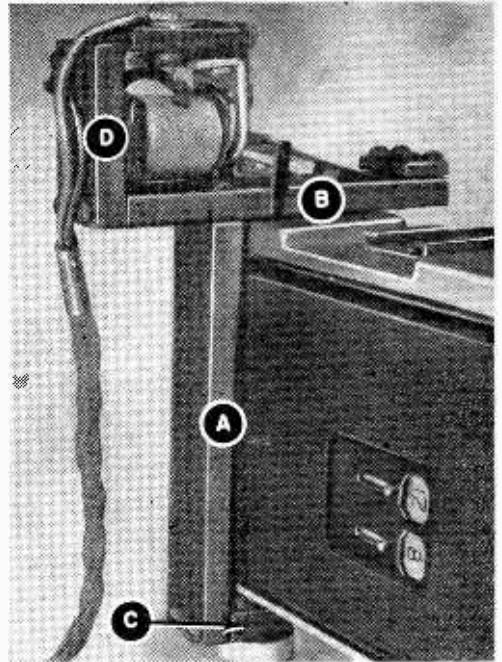

Solder the trip bar (*I*) to the relay armature so that it engages the backstop. Then hook any length of lamp cord in series with a 6-volt battery and push button to the coil lugs.

Operation is as follows: The end of the spring is put on the support. Pushing the button energizes the relay coil, pulling the armature, causing the trip bar to pull the support far enough to release the spring. The spring drops, and the stud depresses the body release, which in turn operates the shutter and takes the picture.

*A. J. Lowe*

# Photographer's Light Distributor

by *louis e. garner*

Those of you who are indoor "shutter-bugs" as well as electronic hobbyists will want to assemble and use this convenient, inexpensive light distribution panel. With it, you can control your floods and spotlight right from your camera position. It eliminates the need for a tangle of assorted extension cords on the floor.

You should be able to duplicate this light distributor for less than five dollars—an equivalent commercial unit would cost two or three times as much. It's easy to assemble—just follow the captions and diagram on the next page. All the parts you will need are shown in the photographs. You can put it together in a single evening—even if you're just a beginner.

With the spring clips on the back of the panel box, snap the unit in place on one of the legs of your camera tripod. Plug the panel's line cord into a wall receptacle and your floodlight and spotlight cords into the switch receptacles on the panel. Simply by manipulating the switches on the panel box, any part of the subject can be thrown into shadow, highlighted or "flatlighted" as desired. You won't have to take your eyes off your model as you change the lighting for just the right effect.





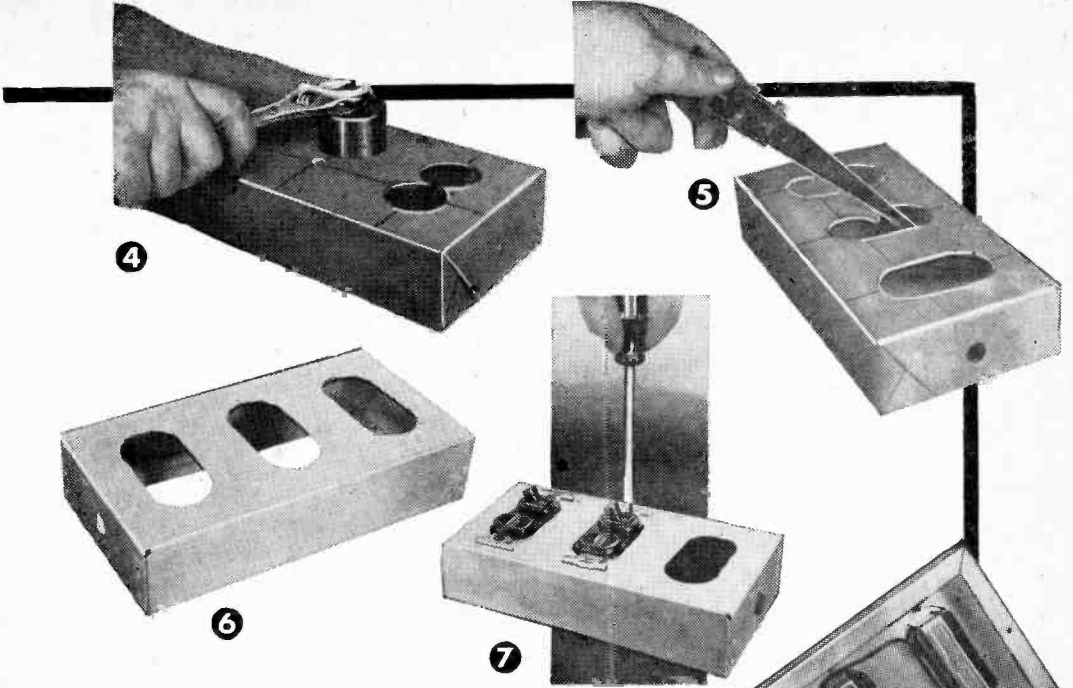

**1** Parts include a 5" x 9½" x 2" aluminum chassis (Bud AC-403), a 5" x 9½" chassis bottom plate (Bud BP-667), and three combination s.p.s.t. switches and receptacles (Eagle 798). Receptacle cover plates may be either plastic or metal. (If you wish, you can substitute a cigar box for the metal chassis.)

**2** Place cover plates in position. Mark location of all holes and cutouts on chassis' paper wrapping. Don't remove paper until machine work is finished.

**3** Drill starting holes at points marked on layout.

**4** To make large cutouts for the receptacles, punch out 1½" holes using a screw-type chassis punch.

**5** Cut between the holes with a small hacksaw. Then drill a ½"-diameter hole in end of chassis for the ½" rubber grommet and line cord. Use 12 to 15 feet of heavy-duty line cord (#16, rubber-covered).

**6** All burrs can be removed with a small file.

**7** Mount switch-type receptacles with screws supplied. Squeeze rubber grommet into end of chassis.

**8** Wire the receptacles in parallel (see diagram) with #18 or larger insulated wire. Secure the line cord by tying a knot in it or using cable clamp.

**9** To use the panel on your camera tripod, mount two spring-type tool holder clips under bottom plate. Mount plate to chassis with four ¼" #6 sheet metal screws (wood screws for a cigar box). Connect heavy-duty line plug to free end of panel's line cord.

**10** Completed unit mounted on tripod, ready for use.

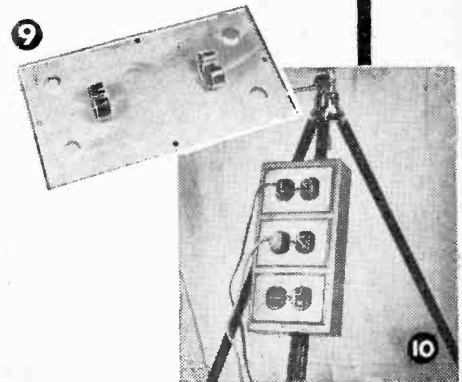
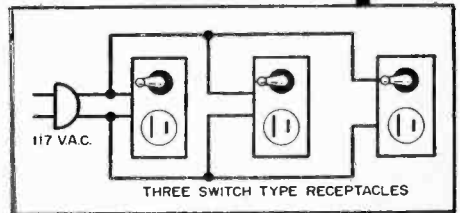

by  
**robert b. tomer**

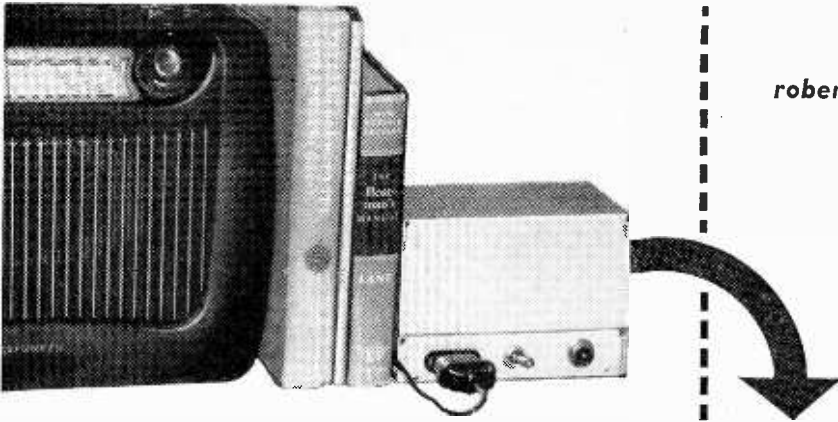

## ***Transistors Replace Wall Outlet***

*for boat or car,  
transistorized oscillator  
changes 12 volts from  
battery to power line-  
operated FM/AM receiver  
or other equipment*

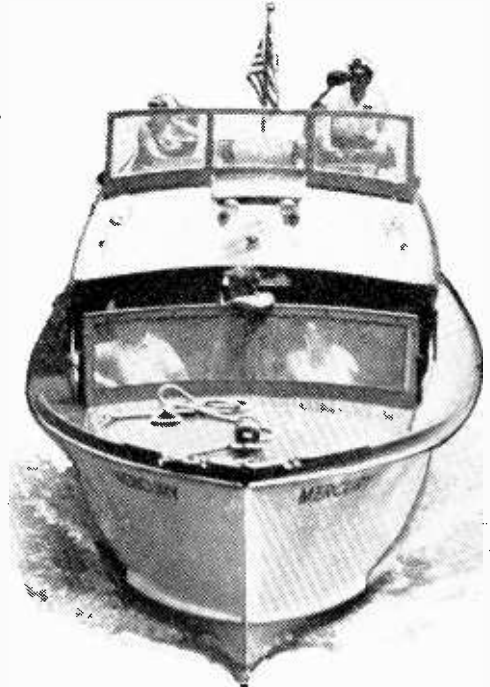

An inverter is a device for changing direct current to alternating current. One type of inverter is used where the only commercial power available is d.c., to make it possible for people to operate a.c. appliances such as radios, TV sets and hi-fi systems. This is the heavy-duty rotary type, which is a motor and an alternator in one housing on the same shaft.

Inverters are also used in cars and boats to convert the 6 or 12 volts d.c. of the batteries to 117 volts a.c., to permit the operation of dictating machines, tape recorders and even television sets. These are the vibrator type, like those found in automobile radios before the advent of transistors. Both types are bulky and draw relatively large currents from the battery.

The author owns a low-current three-way portable radio, designed to cover the broadcast band, the FM band, and the low-frequency beacon band, and wanted to use this radio on board a small cruiser which had a 12-volt d.c. electrical system. It *could* be

be operated from its internal dry batteries, but since it contains quite a number of tubes, battery life would be relatively short. Intended for use as a "standby" unit, the radio might be expected to operate for hours at a time on a cruise.

The most desirable situation would be to be able to draw power for the set from the 12-volt system while under way, or while at anchor. If the 12-volt supply should become exhausted, as a result of running other shipboard electronic gear, the radio's internal batteries would always be available for emergencies.

An inverter was needed which would convert the 12 volts d.c. to 117 volts a.c. at the lowest possible drain. Several small vibrator supplies were investigated, but after considerable time and effort spent in unsuccessful attempts to filter the "hash" out of the radio (radio interference caused by vibrators), they were abandoned. Their power drain would have been excessive even if the filtering had been successful.

The answer was found to be the transistor inverter shown in Fig. 1. The finished unit could have been smaller, but it was convenient to build it on an available 6" x 4" x 4" aluminum chassis. It weighs less than a pound and draws less than an ampere from the 12-volt system when operating the radio. It has no moving parts and is completely silent. No filtering other than a 0.1- $\mu$ f.d. capacitor is needed.

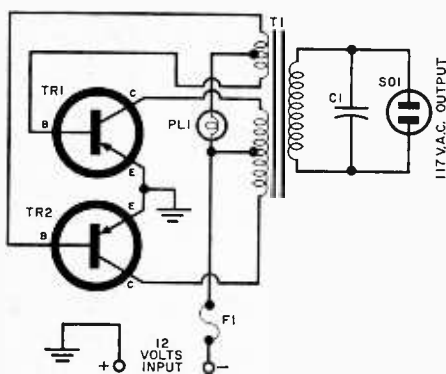

### parts list

- C1—0.1- $\mu$ fd., 600-volt capacitor
- F1—4-amp., 32-volt fuse (Littelfuse Type SFE)
- PL1—Pilot light (G. E. #1815)
- S01—Power socket
- T1—Special transformer (Thermador 6L6000)
- TR1, TR2—2N256 p-n-p power transistor
- 2—6" x 4" x 4" aluminum chassis

### how it works

The inverter works as a free-running oscillator. One transistor starts it by drawing somewhat more collector current than its mate, due to the inevitable differences that exist between transistors.

As its collector current flows through transformer T1, it induces a current in the base winding. This winding has been so connected that the current is in the right direction to bias its base more negatively, and more collector current flows.

At the same time, because it is a transformer, the other end of this base winding is going positive, and this is being fed to the other transistor. The positive flowing current keeps this transistor "turned off."

The conducting transistor keeps on conducting as long as the rising collector current is matched by a rising base current. Eventually, the transformer core material saturates and its field commences to collapse.

When this happens, the current in the base winding suddenly reverses, the conducting transistor is switched "off," and the one that was not conducting is switched "on." This results in a square-wave voltage being induced in the secondary. It is this voltage stepped up which is used to operate the radio.

Output frequency is close to 60 cycles.

### construction

The original model of transistor inverter was built around a home-made transformer. There is now available a transformer which will exactly fit this job. It is Type 6L6000, made by Thermador Electrical Mfg. Co., 2000 S. Camfield Ave., Los Angeles 22, Calif.

Transformer T1 is mounted on a small aluminum chassis, made by cutting the top off a 6" x 4" x 4" chassis. Cut it one inch deep so that you have a 6" x 4" x 1" chassis. A second chassis, having the original dimensions, is used as a cover for the unit when it is finished.

Mount the two power transistors, TR1 and TR2, being sure to use mica insulators under them to prevent their shells from contacting the chassis directly. Use fiber insulating washers under their mounting screws. The transistor case is connected internally to the collector, and this must not be allowed to ground. You can check to be sure TR1 and TR2 are not grounded by using an ohmmeter and measuring between case and chassis. If only a few ohms are read, locate and eliminate the short.

After mounting the transistors, mount the on-off switch, a pilot light socket and the a.c. outlet socket. Terminals will be needed for the 12-volt input connections and a fuse block is added for safety.

The wiring consists merely of connecting

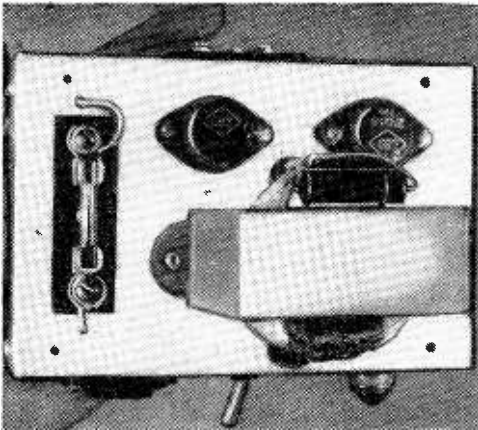

Chassis of inverter makes a convenient handful. Be sure to insulate the transistors from the chassis.

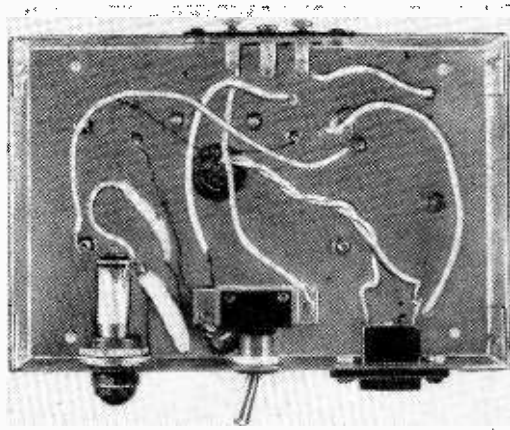

All parts and wiring are placed in the shallow chassis; the other one is used only as a cover.

the appropriate leads from  $T1$  to  $TR1$  and  $TR2$  and to the output. Connect the pilot light,  $C1$ , and the unit is ready for test.

In testing the unit, a scope is most valuable, but an a.c. voltmeter will do. A variable d.c. source is also desirable. Connect the inverter to the d.c. supply with the input reduced to one or two volts. Be sure the battery's positive terminal is grounded to the chassis.

Observe the a.c. voltmeter connected across the output receptacle and note the voltage at the reduced d.c. input. If it shows nothing, reverse the two leads which go to the base connections of the transistors. The meter will now show voltage.

Increasing the input to 12 volts should cause the meter to read around 150 volts a.c., without a load connected. Pilot light  $PL1$  should light dimly. Plug a small, three-way portable radio into the outlet socket. A 10-watt, 117-volt bulb may be substituted if desired.

*No load drawing more than 10-15 watts should be plugged into this inverter.* When a load is applied,  $PL1$  should brighten to full brilliance. The inverter is functioning normally if the input current, when loaded to about 10 watts, is around 1.0 ampere. This will indicate an efficiency of around 80 to 90%. The unloaded input current should be about half that amount.

The base of each transistor returns to the negative side of the battery through the base winding center tap and then through the pilot light. When the system is turned "on" and the oscillations have not as yet started,  $PL1$  is cold and its resistance is quite low.

The battery voltage divides across the input resistance of the base diodes and  $PL1$ 's cold resistance. This places a high forward bias on both  $TR1$  and  $TR2$ , insuring their starting, even under a full load.

When oscillations start, this heavy base current is unnecessary and would not be economical; so it is desirable to cut it down. This is done automatically by  $PL1$ 's rise in temperature as the increased base current flows through it. The hot resistance is several times the cold resistance, and this automatically reduces the base current to the desired level.

One of the nice things about transistor power supplies and transistor inverters is that in the event they are overloaded, they "fail safe" and stop oscillating. When they do, their current drain drops to a very low value dependent upon the fixed bias on the transistors. Thus, you cannot burn up a transistor power supply if the load short-circuits. But on a boat, no amount of caution is too much, and in case some part of the primary circuit shorts to ground, the fuse will help prevent a fire from occurring.

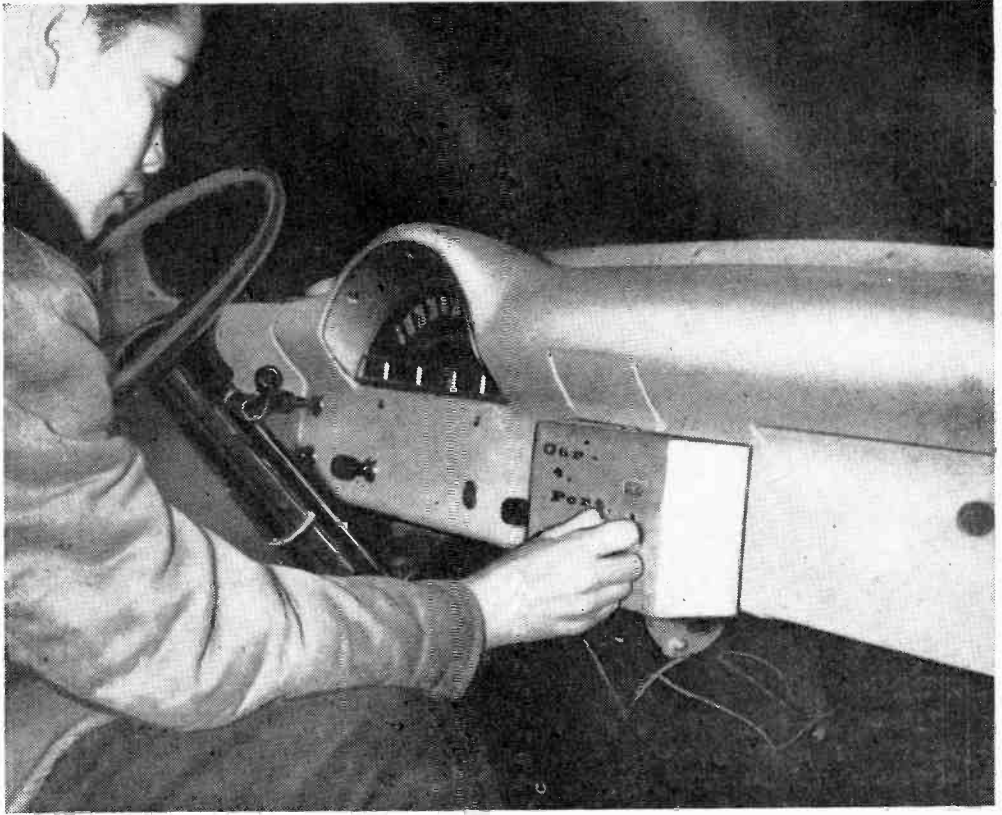

**M**ANY PEOPLE want to know if it is possible to purchase a portable radio and operate it in an automobile as well as take it on a picnic. It *is* possible. But the portable would have to be built in a metal case to shield it from the ignition system. And inasmuch as the metal car top and body would prevent the radio waves from reaching the built-in antenna of the set, an outside antenna must be installed.

At our service shop, one persistent questioner, a salesman, persuaded us to tackle the job of installing an Admiral seven-transistor radio in his car. He insisted that if it could bring in only one station he would be well pleased. He also wanted to be able to operate the set in a hotel room.

A small aluminum box was obtained, and holes for the dial and volume control were

## how to convert transistor set for car

by *homer l. davidson*

*simple installation provides operation as auto radio  
which can be removed for regular portable use*

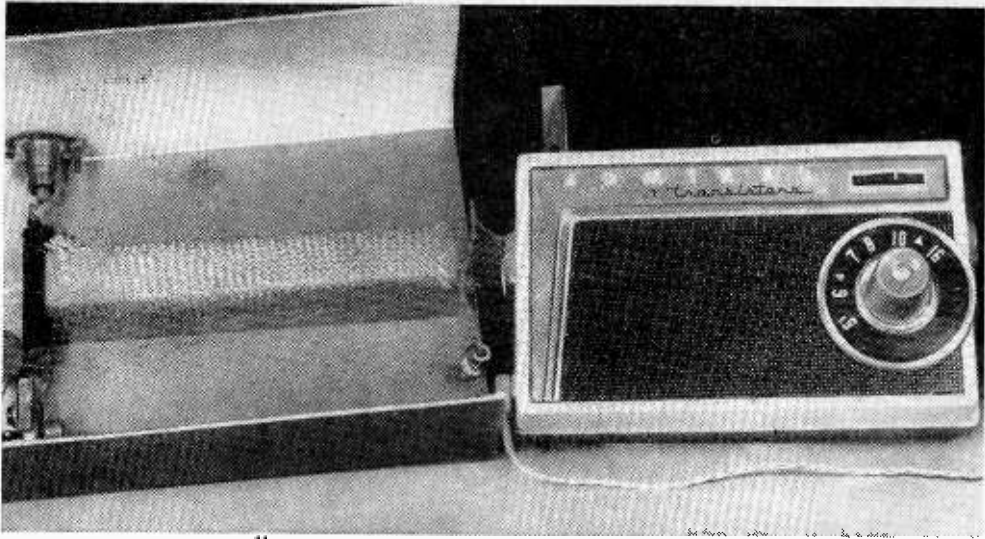

Padded wooden blocks can be used to hold receiver securely inside metal box. On some cars, there might be enough space behind the dashboard for mounting both the set and the speaker.

made to the dimensions shown in Fig. 1. (For other receiver models, different layouts and hole sizes are required.) The screw that holds the dial plate to the radio was removed and a longer knob was placed on top of the regular dial with a longer screw holding the knob in place.

Pine blocks 1"-thick are fastened inside the metal box to hold the set securely in place. Felt glued over the blocks prevents the plastic cabinet from being scratched.

The antenna jack and a homemade r.f. filter coil are mounted on one side of the metal box. The filter coil consists of 50 turns of No. 24 enamel wire wound over a  $\frac{1}{4}$ "-thick, 1-megohm resistor. Bolted to one side of the chassis is a small padder capacitor. These components are connected as shown in Fig. 2.

A fixed capacitor is wired into place from the capacitor and coil to a small female socket, which connects the antenna connection from the transistor radio to the outside antenna. The coil and button capacitor form an r.f. filter coupling network. The padder capacitor tunes the outside antenna to the input of the radio receiver; it should be tuned for best performance when a station is being received around 1400 kc.

There is an output jack on the transistor radio for an earphone. The same type earphone plug can be connected to an external 6" x 9" loudspeaker. This is a permanent-magnet car type and it is mounted in the regular speaker grille work of the automobile dashboard.

The shielded side of the speaker cable is grounded to the car and also to the speaker frame, as shown in Fig. 3. This helps keep the auto ignition noise from entering the speaker cable and getting into the radio. If desired, small holes can be drilled in the aluminum case and the set's internal speaker used. With the larger speaker, both volume and tone are much better. On local stations the volume is surprisingly high.

After being wired up, the unit was tested on the bench before being mounted in the automobile.

Wing nuts are used so that the radio can be easily removed to serve as a separate portable. A small metal flange is bolted to the bottom of the metal box and in turn bolted to the bottom of the dash frame. The speaker is mounted into the grille and properly grounded.

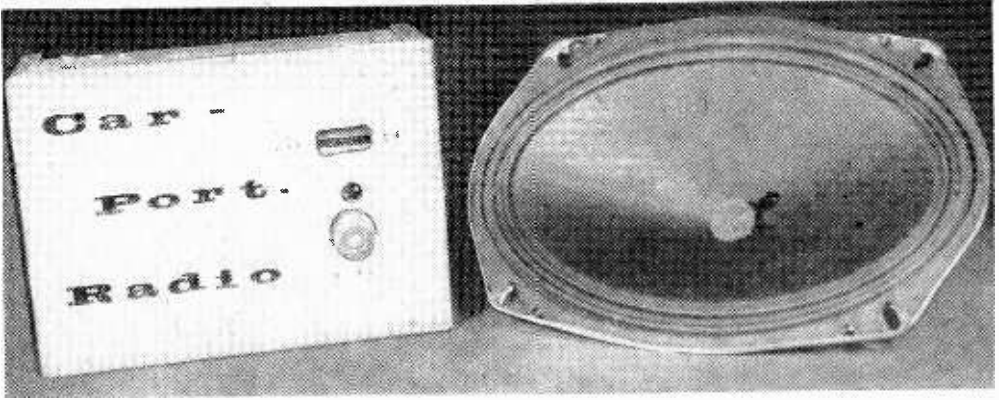

When installing the outside car antenna, care must be taken to make sure that its metal washer bites into the metal of the body. The shielded lead-in wire should be bonded to the car fender or top cowl mount. Sometimes it is best to scrape around the reamed hole so that undercoating and dirt will not make a poor connection resulting in excessive ignition noise.

This converted portable was mounted in a new car and there was no prominent motor noise. A distributor suppressor was added in case ignition noise should develop in the future. In some older cars, a distributor suppressor or generator capacitor may be needed to eliminate the noise.

Of course, this converted radio wasn't built as a commercial car radio, so it won't perform as well. But instead of getting one station for our salesman, there are at least six stations whose volume has to be turned down for pleasant reception. The author does not recommend using a portable that has less than seven transistors, however.

Fig. 2. Circuit for additional parts needed to feed set from conventional auto-radio antenna.

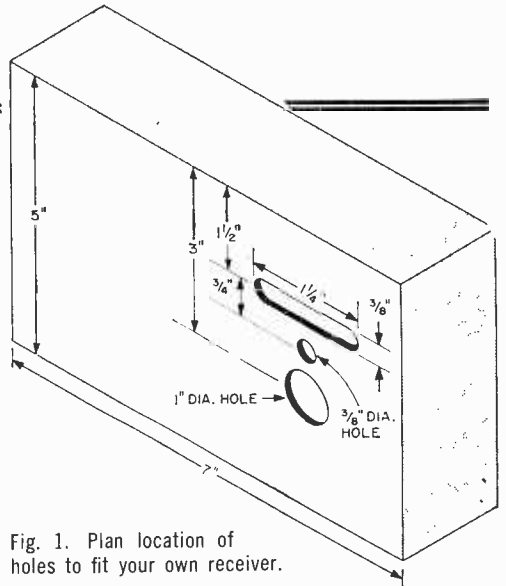
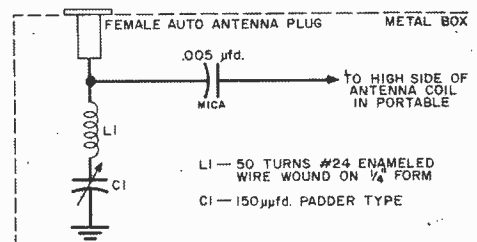

Fig. 1. Plan location of holes to fit your own receiver.



L1 — 50 TURNS #24 ENAMELED WIRE WOUND ON 1/4" FORM  
C1 — 150 μfd. PADDER TYPE

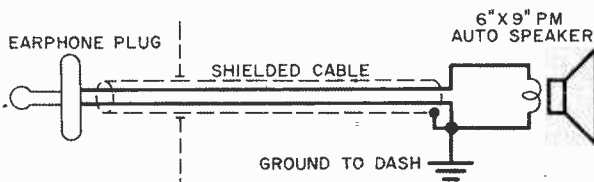

Fig. 3. Wiring of extra speaker to be permanently mounted in car. When the set is used away from the car, its built-in speaker operates.

# Squawk with the Transihorn

*transistorized all-purpose horn  
is handy on boats, for civil defense,  
or any other need*

*by louis e. garner, jr.*

Chances are that you could use a self-contained, reasonably powerful electric horn for club, civic, school, Civil Defense, sporting or other activities. If you're a boating enthusiast, maybe you've been looking for an inexpensive foghorn that won't place an excessive drain on your boat's electric system.

With inexpensive power transistors, it is possible to design a fully transistorized electric horn that has plenty of volume but needs relatively little power. The "Transihorn" requires so little current that it can be operated from a small, self-contained battery.

A 7"x5"x3" aluminum box serves as housing for the circuitry and battery and as mounting base for the horn, a small University "Cobra" paging trumpet.

The box separates into halves: the upper half is used for housing the electronic circuitry, for mounting the trumpet and the

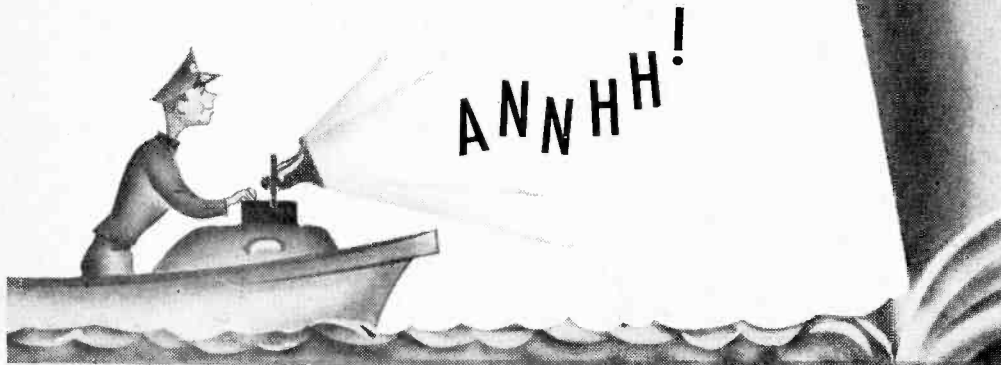



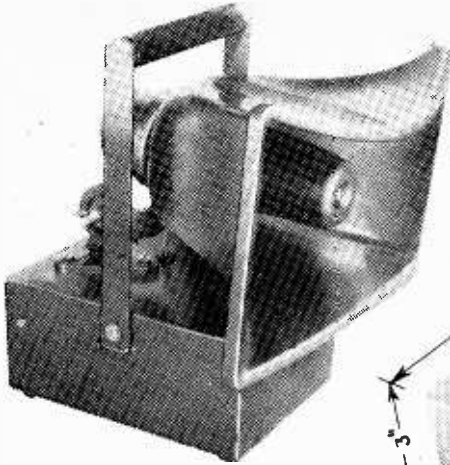

The holes to be drilled in the chassis and transistor heat sinks are shown below. Note that the two heat sinks must be insulated from the chassis and each other by means of fiber or mica washers.

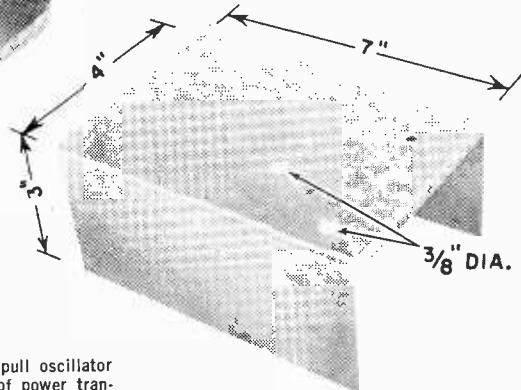

### how it works

This circuit is basically a transistor push-pull oscillator direct-coupled to a paging trumpet. A pair of power transistors is used with a transformer to provide parts of the oscillator load and also the feedback necessary for oscillation. The two transistors are cross-coupled, with the "output" signal of one serving as the "input" signal for the other.

Due to inherent minor differences in the characteristics of the transistors, one will conduct more heavily when S1 is first pressed. As the collector current of TR1 (for example) starts to increase, a positive-going signal is developed between its collector and emitter electrodes. At the lower end of the primary winding, this shows up as a negative-going signal.

The positive-going signal developed on the collector of the upper transistor is coupled through C2 to the base of the lower transistor, reducing its collector current and further aiding in the development of a negative-going signal between its collector and emitter electrodes. This negative-going signal is coupled through C1 back to the base of TR1, tending to increase collector current. And the cycle continues.

The signal developed by this type of oscillator is not a sine wave. It approaches a square wave in general form, and is very rich in harmonics, giving the output sound obtained from the trumpet a penetrating raucous quality comparable to that obtained with a conventional electromechanical horn.

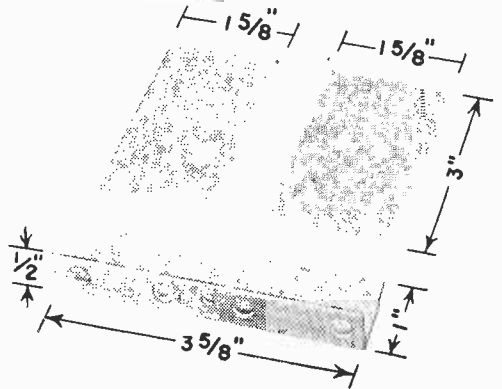

carrying handle; the lower half holds the 6-volt battery (Burgess F4P1) which is secured with an aluminum bracket.

Two CBS-Hytron 2N255 power transistors are mounted on aluminum heat sinks measuring about 3"x1 5/8". The heat sinks are mounted on an aluminum angle bracket secured to one side of the upper half of the case. Fiber washers insulate them from each other and from their common mounting bracket. Mount a three-terminal tie-point strip on each of the heat sinks for connecting the transformer leads and other components.

Secure the trumpet, output transformer and heat sink mounting brackets with standard machine screws, hex nuts, and lock washers. The "on-off" switch (S1) is an s.p.s.t. momentary push-button type mounted on the top half of the aluminum case. The carrying handle is made from two straps of aluminum, 1/8" thick by 3/4" wide by 7 1/2" long, and a 3/4" by 5" wooden dowel rod.

When wiring, remember that the transistor's collector is internally connected to its metal shell. Thus, the collector connections are made to the heat sinks. Base and emitter connections are either soldered to the pins (if soldering is done quickly) or made with clips salvaged from a 7-pin tube socket. Note that the normal "secondary" leads of the

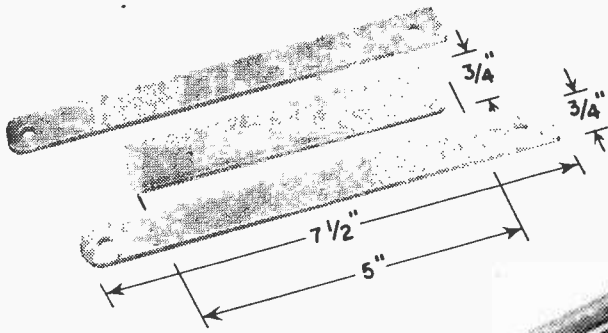

Dimensions for the parts of the handle are given at left. Battery mounting clamp is made of a length of angle iron as shown below.

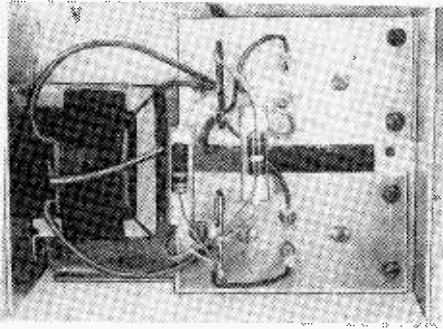
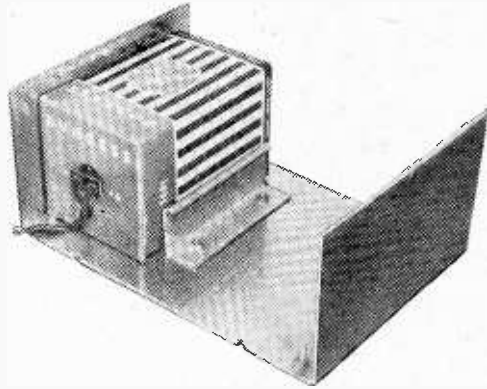

#### parts list

- B1—6-volt battery (Burgess F4P1)
- C1, C2—160- $\mu$ fd., 15-volt electrolytic capacitor (Lafayette CF-127)
- R1, R2—68-ohm, 2-watt resistor
- S1—S.p.s.t. push-button switch, normally open

Placement of the heat sinks and transformer is shown in photo above. Note that the collectors of both transistors used in the Transihorn are connected internally to shell.

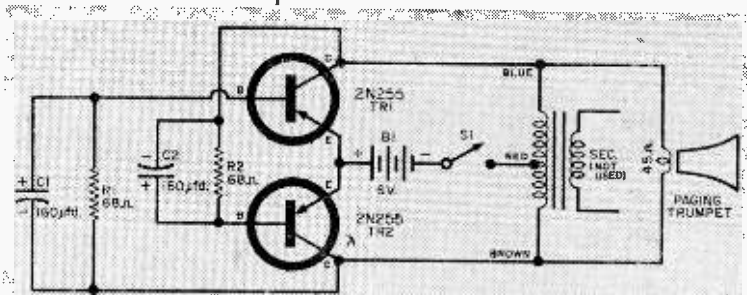

transformer are *not* used. These can be taped to one side, but take care that the free ends do not short.

#### modifications

There are several changes that can be made in construction. You could substitute a "standard" paging trumpet (such as a University Type MIL-45) for the "Cobra." An ordinary loudspeaker might be used for indoor applications, provided the speaker has a 45-ohm voice coil. A loudspeaker or paging trumpet with a low-impedance coil will do if you connect its leads to the transformer *secondary* (rather than across the blue and

- TR1, TR2—2N255 transistor (CBS-Hytron)
- 1—Transistor output transformer, 48 to 3.2 ohms, secondary winding not used (Argonne AR-503)
- 1—5" x 7" x 3" aluminum case
- 1—Cobra-type trumpet, 45-ohm voice coil (University CMIL-45)
- Misc. rubber feet (4), 3-terminal tie points (2), sheet aluminum, wooden dowel, shoulder and flat fiber washers, battery plug, etc.

brown primary leads as in the schematic.)

You can change the tone quality of the signal by substituting different-value coupling capacitors for C1 and C2, or by connecting a capacitor (0.02 to 0.5  $\mu$ fd. at 400 volts) across the transformer primary. Almost any 6-volt battery will do.



## Go Mobile with the "Auto-Fi"

Many hi-fi fans have attempted to improve their listening pleasure in the family automobile by adding a rear-seat speaker. The "Auto-Fi" will give you better response than mounting a speaker in the trunk cavity of your car.

The enclosure must be compact. And it must use a relatively small single opening, since it would be difficult to cut additional holes in the rear shelf.

The speaker used in the model is a 6"x9" coaxial oval speaker, Lafayette SK-75. Cross-over is obtained automatically without a separate network. Experiments showed that a parallelogram speaker opening would be satisfactory with the use of an oval speaker, which simplified construction.

### angling the speaker

Parts for the enclosure are shown in Fig. 2. They are cut from  $\frac{3}{8}$ " plywood. Blocks are pine.

The speaker mounts on a separate mounting board  $8\frac{1}{2}$ "x $9\frac{1}{4}$ " which is set back from the front panel by two  $\frac{3}{8}$ "x $\frac{3}{8}$ "x $8\frac{1}{2}$ " spacing blocks, like a sandwich, allowing for air space (see Fig. 1). Both the speaker on the mounting board and the parallelogram opening in the front panel are angled with respect to the long dimension of the enclosure. This gives better sound dispersal.

Glue  $\frac{3}{4}$ "x $\frac{3}{4}$ "x $9\frac{5}{8}$ " bracing blocks to the long edges of each end piece. Use wood clamps to hold the glue joints securely. When dry, drill pilot holes and install  $\frac{3}{4}$ " wood

*improve auto radio listening*

*with novel enclosure*

*by b. van sutphin*

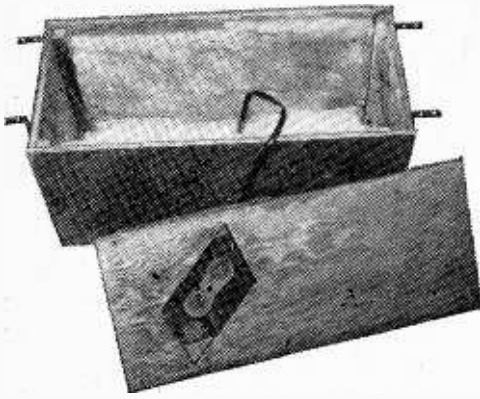
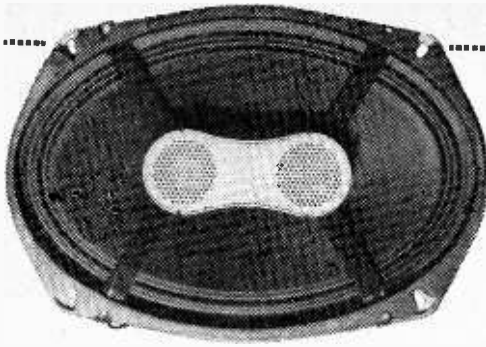

screws previously dipped into the wood glue. Use enough screws to hold solidly.

Temporarily clamp the sides in place and drill pilot holes for installing  $\frac{3}{4}$ " wood screws to hold the side pieces to the bracing blocks. Be sure to fit the side pieces flush to the back. They will overlap  $\frac{3}{8}$ " to allow for mounting the front panel. (See Fig. 1.)

Place the back on the enclosure. Pilot holes should be drilled at the four corners at the bracing blocks. Use  $\frac{3}{4}$ " wood screws dipped in wood glue.

Prepare the front panel for the enclosure by following Fig. 2. Draw the parallelogram and cut it out with a keyhole or jig saw. The edges can be smoothed with a wood rasp.

Now cut the angled ellipse in the center of the speaker mounting board. A template is convenient for marking the cutting line. If you do not have one, place a sheet of paper

Unusual Lafayette oval twin-tweeter speaker shown at top of page is ideal for the car enclosure seen opened up directly above. The speaker can be seen through the parallelogram opening. While it's not evident above, the speaker is actually mounted on a board separated from the front panel by two spacing blocks made of pine.

Fig. 1. Note the exact construction details (at right). You can see the sandwich effect of the speaker mounting board separated from the front by spacers.

Fig. 2. Parts for the enclosure (on page 83). Cut elliptical opening for speaker in mounting board and parallelogram in front panel as shown in diagram.

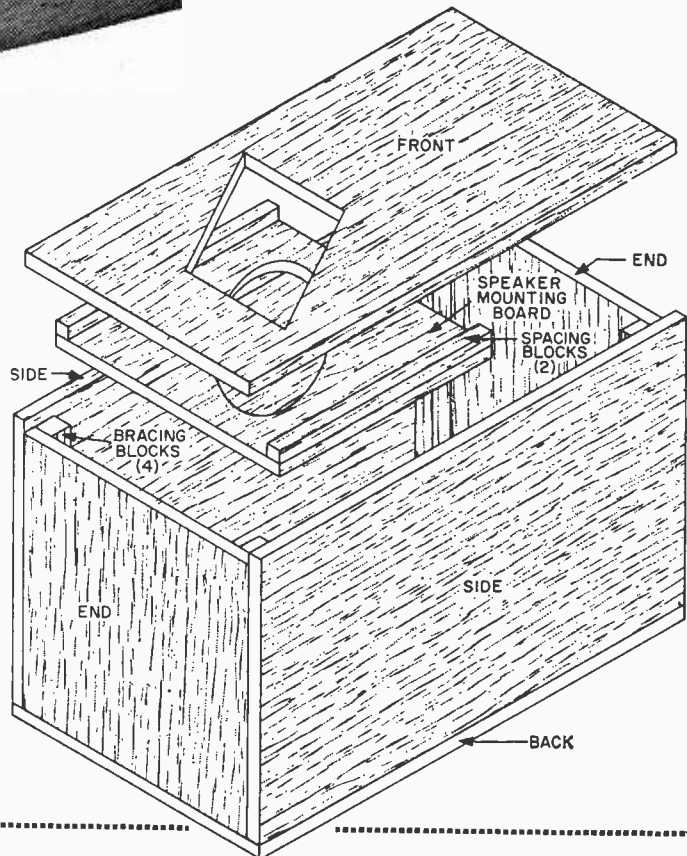

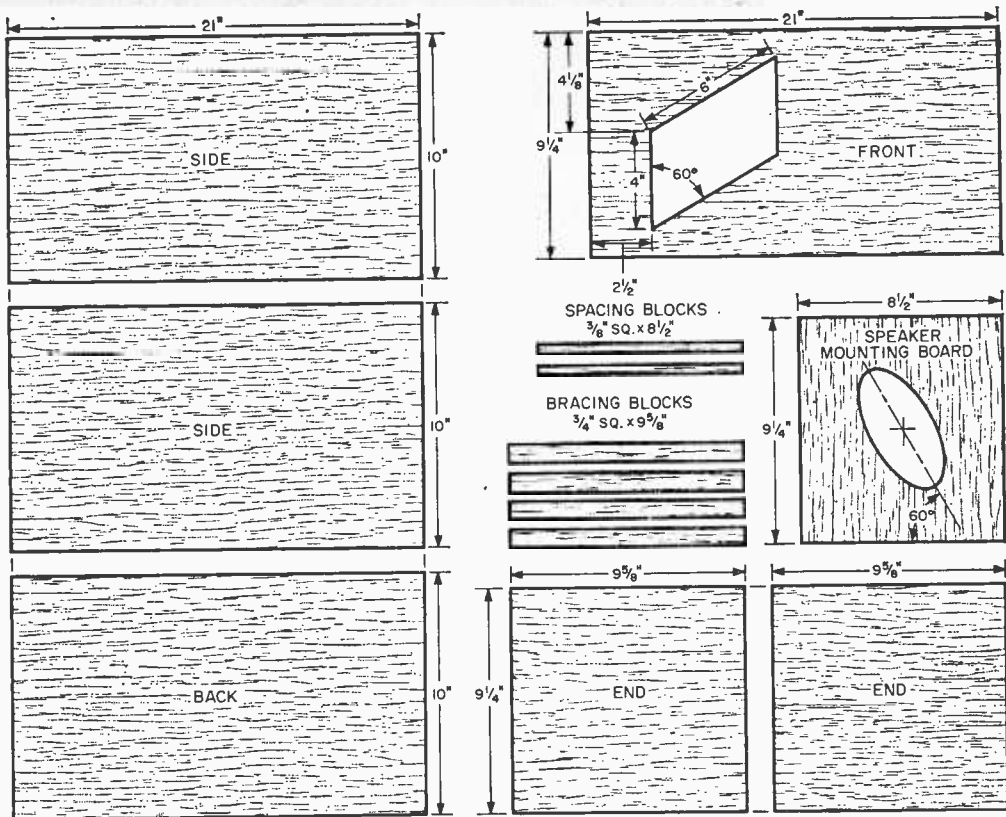

over the front of the speaker and trace, lightly around the *inside* edge of the speaker rim. First, mount the sound insulating material. No insulation is used on the front panel or the end nearest the speaker. Insulation is required on both sides, the back and the end farthest from the speaker.

For best results, spread a thin layer of glue where the insulation is to be placed and cut the insulating material to size. Staples at various points—most desk-style staplers can be opened for tacking—will hold the material while the glue dries.

Mount the spacing blocks on the front panel. The ends of these blocks must be 1 1/8" from the end of the front panel. Use glue and wood screws for secure mounting.

Mount the speaker on its board and mount the board on the spacing blocks. Drill a hole in one of the enclosure sides for the speaker leads to pass through, then connect the speaker leads. (The Lafayette SK-75 speaker has two terminals connected to the woofer voice coil. One of these terminals is also connected to the tweeter assembly. Connecting the other terminal to the speaker frame puts the two tweeters in parallel with the woofer.)

After passing the leads through the hole, place the front panel in position and drill pilot holes for the mounting screws. The screws must go through the panel and into the ends of the bracing blocks at the four corners. Do not use glue—1" wood screws will hold the panel securely while allowing easy removal.

Mount the enclosure beneath the rear shelf, under a hole slightly to the right of the car center. To hold the unit in place, use stove bolts passing through angle brackets screwed to the ends of the enclosure.

It may be necessary to drill holes in the shelf to obtain proper positioning. Use two nuts on each bolt for positive locking action.

The enclosure must be tight against the shelf to prevent vibration, and also to prevent air leakage into the trunk. Glue insulating strips around the underside of the shelf hole.

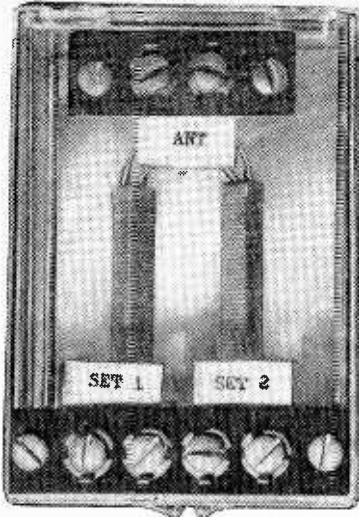

Front view of the two-set coupler showing screw terminal arrangement used for maximum convenience.

## Make Your Own Two-Set Coupler

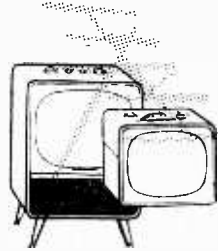

by  
rudolf f. graf

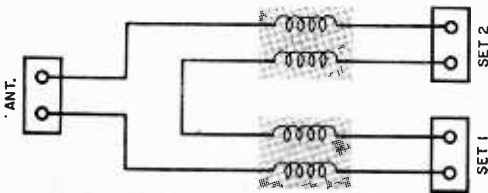

Shaded areas in schematic above represent coils.

Rear view of coupler. Cutouts in the plastic may be made with hand grinder or with drill and file.

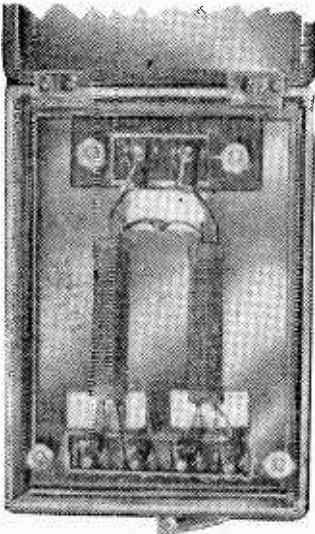

Two TV receivers, or one TV and one FM receiver, or two FM receivers can perform satisfactorily using the signal from just one antenna. A little device called a two-set coupler does the trick. Here's how it works.

The signal from the antenna is fed down from the roof by way of the transmission line, then connected to the coupler (see diagram). Inside this coupler, the signal is divided and sent to both sets. In many locations, the fact that the entire signal voltage is not available to either set will have no noticeable effect on the picture quality.

Two-set couplers are available commercially, but it's fun to make one. And you'll find that it is easiest to build the coupler in a small plastic box.

The coils are known as "bi-filar" or "balun" coils and are commercially available from Lafayette (TS-269), Olson Radio Warehouse (L-68), or your local parts jobber.

The schematic and the inside view of the coupler show how the coils are wired. The two leads from one end of each coil go to the Set terminals, and the other ends are in series and connected to the Ant. terminals. Since there are no primary or secondary connections to worry about, the wiring job is simple.

If you want to operate one TV receiver on the coupler with the other set disconnected temporarily, installing a 300-ohm resistor at the unused coupler terminals may improve reception.

## section **IV**

### receivers you can build

pocket f-m receiver	<b>86</b>
build a half pack	<b>88</b>
monoceiver pulls in d-x	<b>91</b>
converter for daytime d-x	<b>95</b>
conelrad your home	<b>98</b>



# Pocket FM Receiver

*sensitive superregen*

*circuit pulls in fm band—*

*without an antenna*

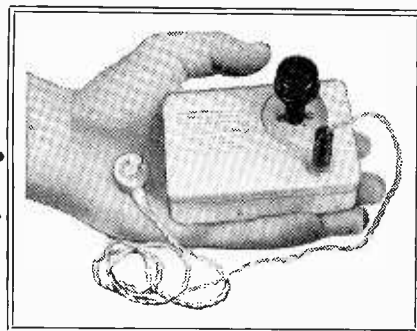

*by herb cohen*

Here's a miniature FM receiver that requires no external antenna, uses only one miniature tube and has good fidelity. The entire FM broadcast band is covered with enough selectivity to separate weak from strong signals even in metropolitan areas.

And it's possible to complete this "under \$10.00" project in just one evening. Component placement is not critical.

## construction

The subminiature 1AG4 tube socket should be pre-wired before installation. Follow the diagram, soldering the plate and screen lugs together and then connecting 2½" lengths of hookup wire as shown. Connect C2, C3 and R1 directly to the grid lug. The tube socket can be glued directly to the case with a drop of Duco cement.

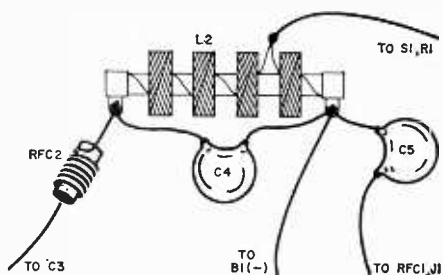

Wiring details of quench oscillator coil L2. Note added coil tap.

Detail view of wiring of sub-miniature tube socket. Red dot on tube is guide for proper installation.

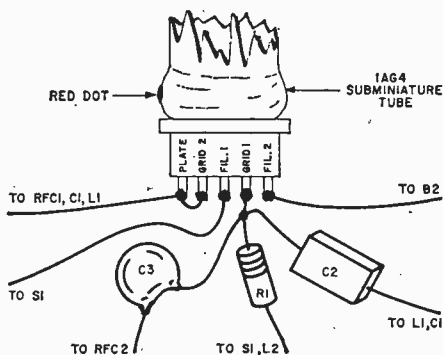
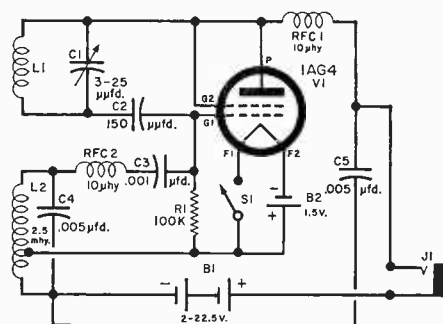

ELECTRONIC EXPERIMENTER'S HANDBOOK



Antenna coil *L1* is made by winding four turns of #14 gauge solid wire around a form  $\frac{3}{8}$ " in diameter. The turns should be spaced as close together as possible without actually touching each other. Remove *L1* from the form and solder its two ends directly across tuning capacitor *C1*. All leads should be as short as possible.

Quench coil *L2* is a four-section 2.5-mh. choke. Tap into *L2* between the first and second section as shown in Fig. 2. Carefully scrape the connecting wire clean and solder a thin flexible 3" lead to the tap.

All components can now be screwed or glued into place. In order to eliminate hand capacitance effect, an insulated shaft extension is used with *C1*. A dynamic earphone of 2000- 3000-ohms impedance should be plugged into *J1*.

### troubleshooting

Before turning the unit on, check for shorts in the wiring. Turn *C1* to full mesh and *S1* to the "on" position. If the unit is functioning, a loud hiss will be heard. Tune *C1* across the band until the hiss subsides and a station appears. A large dead area may appear at the high end of the FM band. If this happens, shorten the leads in the tuning circuit.

If a hiss is not heard, touch *C1* with an insulated screwdriver. A click should be heard indicating that the ultra-audion section is oscillating but the quench circuitry is not functioning. Check all components, particularly the tap on *L2*, for a short, break or wiring error. Check battery voltage—if *B2* drops below 1.3 volts, oscillation will be difficult to obtain.

One method of calibrating your set to cover the entire FM band is to place the pocket receiver near a commercial FM set. Tune the commercial FM receiver to 88 mc. Then tune *C1* until a rushing noise is heard. Mark this spot on the pocket receiver's case. Repeat this procedure for the upper end of the FM band at 108 mc. If the high end of the band does not come through, spread the turns of the tuning coil *L1* slightly. Compress to obtain the low end of the band.

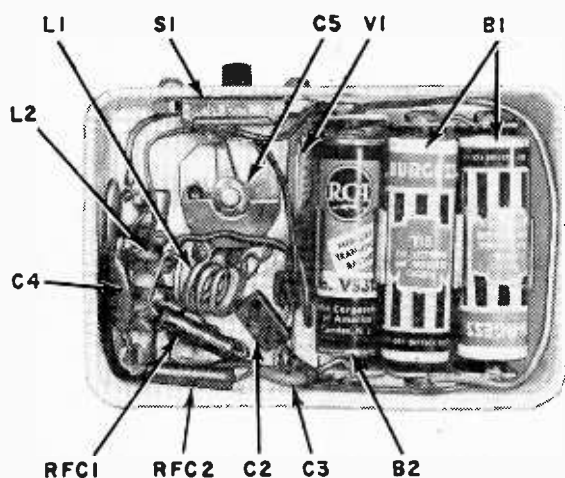

Parts placement shown should be followed carefully for best results. Consult the detail view above for exact positions. All leads should be as short as possible.

### how it works

Through the use of a superregenerative type detector, gain comparable to a full superheterodyne receiver has been obtained. The circuit utilizes two separate oscillators. The first, an r.f. ultra-audion type, is tuned by *L1* and *C1* to the incoming r.f. signal. The interelectrode capacitance

of *V1* is used to provide the feedback to sustain the oscillation. A quench oscillator of the Hartley type, whose tank circuit is *L2* and *C4*, switches the grid circuit of *V1* on and off at a 30-kc. rate. Its only purpose is to interrupt the high-frequency oscillation.

An r.f. signal appearing in the tank circuit triggers the ultra-audion oscillator on before its normal period and keeps it on slightly after the quench frequency would normally kill it. The "extra" period of oscillation by the ultra-audion section results in a large plate current change. This appears as the audio signal in the earphone. Since the incoming r.f. signal is used only as a trigger to fire the high-frequency oscillator, the over-all gain of the circuit is not dependent either on the strength of the incoming signal or the gain of the tube.

### parts list

- B1—2-22.5 volt battery (Burgess Y15)
- B2—1.5-volt penlight cell
- C1, C2—0.005  $\mu$ fd. disc ceramic capacitor
- C3—0.001- $\mu$ fd. disc ceramic capacitor
- C4—150  $\mu$ fd. mica capacitor
- C5—3-25  $\mu$ fd. variable capacitor (Hammerlund APC-25)
- L1—Four turns of #14 solid wire (see text)
- L2—2.5-mh. Choke (Miller 4537)
- R1—100,000-ohm,  $\frac{1}{2}$ -watt resistor
- RFC1, RFC2—10 $\mu$ h. choke (Miller 4612)
- S1—S.p.s.t. slide switch
- V1—1AG4 electron tube
- 1—Plastic shaft extension
- 1—Plastic cabinet (Lafayette MS-302)
- Misc. subminiature tube socket, battery holders, wire, etc.



by *francis j. leyva*

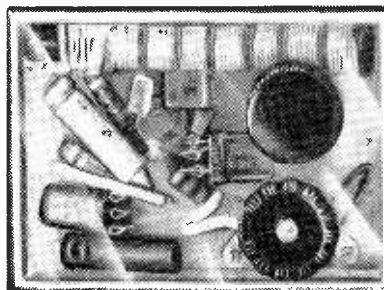

# build a half pack

*tiny transistorized receiver  
uses homemade printed circuits*

With a power consumption of about one milliwatt, and using the new miniature dynamic earphones, this receiver will deliver earsplitting volume on local stations. A little more than half the size of a king-size pack of cigarettes, its power supply is a single 1.3-volt mercury cell which is called on to supply about one milliamperere of current at full volume. It needs no external antenna, although one can be employed in low-signal areas.

Two printed-circuit boards (*PC1* and *PC2*) are used (see parts list). Cut out the laminate to sizes shown in templates on page 90. Clean the two boards with steel wool until they are shiny. With a straight-edge and compass, transfer the conducting lines to the laminate board. The width of the conductor strips should be about  $\frac{1}{16}$ " and the connection points should be about  $\frac{1}{8}$ " in diameter.

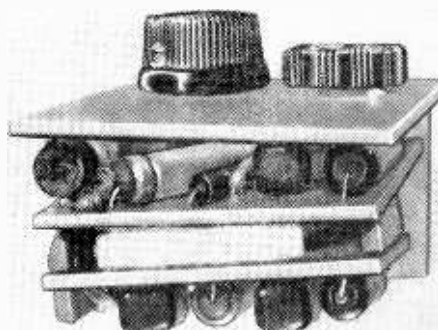

**Side view** of the completed assembly. Note the small wooden spacers glued between the two printed-circuit chassis boards. The three sides and the bottom of the chassis are installed later.

Use the dark areas on the templates as guides when applying the resist. To make the connection points for the transistors close together, draw a line about  $\frac{1}{2}$ " long with a ball-point tube, or put down a strip of tape and divide it into three parts with a razor blade. These parts become the terminals for the transistor leads.

## how it works

The first transistor (TR1) is an r.f. type used as a grounded-base regenerative reflex detector. Antenna coil L1 picks up a radio signal and induces an identical signal in the tickler coil (L2). The latter feeds this signal to the emitter of TR1. The signal is amplified and passes through L1, which is in the collector (output) circuit. As a result, a large signal is induced in L2 and the cycle repeats itself. This is what causes regeneration.

That part of the r.f. signal induced in L2 is detected by the emitter and base junction of TR1. The audio voltage developed across R3 and C5 is reapplied to the emitter and base, amplified, and coupled to the CK722 transistor TR2.

TR2, TR3 and TR4 form a simple three-stage audio amplifier. It differs from many other transistor amplifiers in that the bases have no bias resistors. The collector leakage current and the minute current leaking through the coupling capacitors is all the bias current that is needed for the small signals that are handled.

points, and a single letter designates a terminal such as one of the transistor electrodes or a battery terminal), and insert all the components in their respective positions but do *not* solder them in as you go along. They are all mounted on the non-etched side of the board with the exception of C1, R1, and the battery holder.

## soldering

If all parts fit well, solder them in place with hot, well-tinned, small-tip soldering iron or gun. Use a special printed-circuit

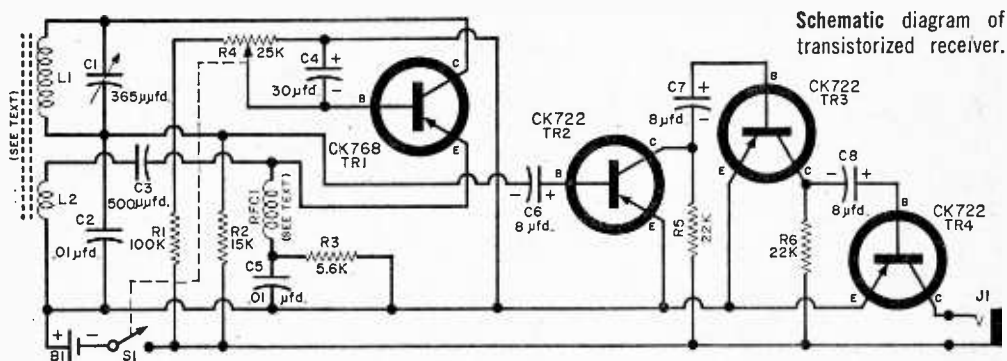

Schematic diagram of transistorized receiver.

If you use liquid resist and a brush, or a ball-point tube, trim the lines with a razor blade after they have dried. This will improve the looks of the board, and minimize the danger of accidental shorts between the closely spaced conductors.

## etching and drilling

After the resist has dried, put the boards in the etching solution. They should be ready if you use the cold etching method.

Next, drill the holes for mounting the components. All are made with a  $\frac{1}{16}$ " drill, except the mounting holes for the tuning capacitor (C1). Two of these holes are  $\frac{1}{8}$ " in diameter and countersunk from the non-etched side of the board. The hole for the shaft of the same capacitor is  $\frac{1}{4}$ " in diameter and countersunk from the etched side of the board. Although the flea clips are intended to be mounted in  $\frac{3}{32}$ " holes, it is better if only the smaller bottom part is fitted into the  $\frac{1}{16}$ " holes.

Follow the lists of connections (two numbers or letters indicate that a component should be connected between these two

solder such as Print-Kote because its low melting point reduces the danger of overheating the etched board and components.

When soldering the parts in place, always

## parts list

- B1—1.3-volt mercury cell (Mallory RM-630)
- C1—365- $\mu$ fd., single-gang, midget variable capacitor (Argonne Poly-Vari-Con)
- C2, C5—0.01- $\mu$ fd. subminiature capacitor (Aerovox P832)
- C3—0.0005- $\mu$ fd. subminiature capacitor (Centralab DM-501)
- C4—30- $\mu$ fd., 6-volt electrolytic capacitor
- C6, C7, C8—8- $\mu$ fd., 6-volt electrolytic capacitor
- J1—Miniature jack (Telex 9240)
- L1—50 turns of #22 s.c.e. wire on  $\frac{1}{4}$ " x  $2\frac{3}{8}$ " ferrite core (Lafayette MS-331)—see text
- L2—Six turns #22 s.c.e. wire on same core
- L3—R.f. choke (winding from a discarded miniature i.f. transformer)
- PC1, PC2—XXXX printed-circuit copper laminated board (one  $2$ " x  $4\frac{1}{4}$ " section cut in two parts— $1\frac{1}{16}$ " x  $2\frac{7}{16}$ " for PC1 and  $1\frac{1}{16}$ " x  $2\frac{5}{16}$ " for PC2)
- R1—100,000-ohm resistor,  $\frac{1}{2}$ -watt resistor
- R2—15,000-ohm,  $\frac{1}{2}$ -watt resistor
- R3—5600-ohm,  $\frac{1}{2}$ -watt resistor
- R4—25,000-ohm subminiature volume-regeneration potentiometer (Lafayette VC-45)
- R5, R6—22,000-ohm,  $\frac{1}{2}$ -watt resistor
- S1—S.p.s.t. switch (on R4)
- TR1—CK768 transistor
- TR2, TR3, TR4—CK722 transistor
- 1—6-oz. bottle of etching solution (Lafayette PE3)
- 1—Roll of resist-tape or ball-point tube (Lafayette PRT-3 or PRTL)
- 12—"Flea" clips for soldering contacts
- Misc. eyelets (0.062" in diameter by 0.093" long); tin, copper or brass for battery holder; plastic cabinet

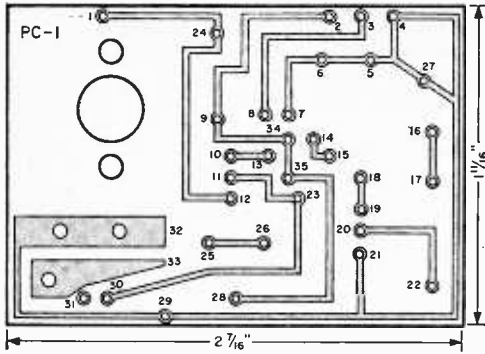

### connections for PC1

- |                          |                            |
|--------------------------|----------------------------|
| 1—Top of antenna coil    | 24—C1 (bottom terminal)    |
| 2—Bottom of antenna coil | 25 and 31—R1               |
| 3—Top of tickler coil    | 25 and 35—R2               |
| 4—Bottom of tickler coil | 25—Wire to PC2, Point B    |
| 5 and 15—R3              | 26—S1 (either terminal)    |
| 6 and 14—C5              | 27—C4 (pos. terminal)      |
| 7 and 34—C2              | 28—C6 (neg. terminal)      |
| 8 and 13—C3              | 29—Wire to PC2, Point A    |
| 9—Top terminal of C1     | 29—Right terminal of R4    |
| 10—Emitter of TR1        | (with prongs facing you)   |
| 11—Base of TR1           | 30—R4 (center terminal)    |
| 12—Collector of TR1      | 31—Left terminal of R4     |
| 13 and 15—L3             | (with prongs facing you)   |
| 16 and 18—R5             | 32—Positive terminal of    |
| 17 and 26—Jumper wire    | battery holder (Part A)—   |
| 18—2" wire to G of PC2   | see text                   |
| 19—Collector of TR2      | 33—Negative terminal of    |
| 20—Base of TR2           | battery holder (Part B)—   |
| 21—Emitter of TR2        | see text                   |
| 22—C6 (pos. terminal)    | 33—S1 (remaining terminal) |
| 23—C4 (neg. terminal)    |                            |

Printed-circuit boards PC1 (above) and PC2 (below) are assembled after components are mounted (right). The battery holder parts (A and B, below) are cut from sheet metal and bent as described in text; folds should be made on the dotted lines.

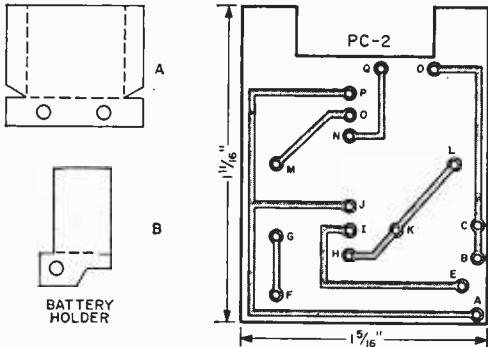

### connections for PC2

- |                              |                            |
|------------------------------|----------------------------|
| A—Wire from 29 of PC1        | I—Base of TR3              |
| B—Wire from 25 of PC1        | J—Emitter of TR3           |
| C and K—R6                   | L—C8 (neg. terminal)       |
| D—Wire to one terminal of J1 | M—C8 (pos. terminal)       |
| E—C7 (pos. terminal)         | N—Collector of TR4         |
| F—C7 (neg. terminal)         | O—Base of TR4              |
| G—Wire from 18 of PC1        | P—Emitter of TR4           |
| H—Collector of TR3           | Q—Remaining terminal of J1 |

hold the leads close to the parts with long-nose pliers to dissipate excessive heat. *Don't*

have the transistors in place when soldering the flea clips to the conductors.

Antenna coil *L1* is wound on a piece of ferrite core which measures  $2\frac{3}{8}$ " x  $\frac{1}{4}$ " in diameter. This coil consists of 50 turns of #22 single cotton enamel wire, and the tickler coil (*L2*) is made from six turns of the same kind of wire. Wind both coils immediately adjacent to each other and in the same direction; otherwise you won't get positive feedback and the detector won't oscillate.

The battery holder consists of two parts: part *A*, the positive terminal, connected at 32; and part *B*, the negative terminal, connected at 33. Trace the pattern of these parts as shown in the diagram (below, left) on brass, tin or copper; then cut them out. Bend them on the dotted line toward you while you hold the parts as shown. Mounting holes for the battery holder are also  $\frac{1}{16}$ " in diameter,

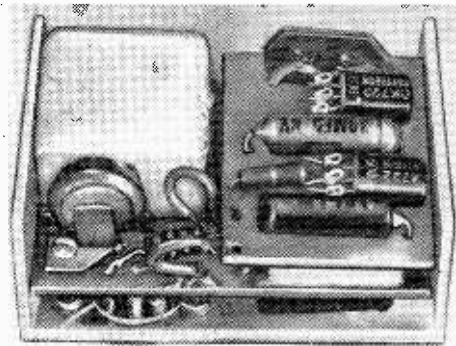

and terminals are riveted to the board using small eyelets or miniature screws and bolts.

Pieces needed to construct a cabinet can be cut from a clear polystyrene sheet. The front and back of the case shown measures  $1\frac{7}{8}$ " x  $2\frac{5}{8}$ ", the top and bottom are  $1$ " x  $2\frac{5}{8}$ ", and the sides measure  $1$ " x  $1\frac{3}{4}$ ". Glue the pieces together temporarily, but leave the back off.

Place the completed "Half-Pack" inside the case and mark the spots for the shaft of *C1* and the regeneration control (*R4*). Drill a  $\frac{1}{4}$ "-diameter hole for the shaft and starting hole of *R4*. With a  $\frac{5}{8}$ " chassis punch, score a  $\frac{5}{8}$ " circle in the plastic. Cut out the circle with a jigsaw. Fasten the potentiometer to the panel through the on-off switch tabs.

The box can now be cemented together. Place the radio inside and drill the mounting holes for *R4* and earphone jack *J1*.

# monoceiver pulls in dx

*miniature one-tube receiver  
for the short-wave listener*

*by forrest h. frantz, sr.*

Here's a "Tom-Thumb" receiver that speaks loud and clear—and uses only *one tube!* It's a real radio with "pull" and selectivity enough for broadcast station separation, even in metropolitan areas. And its simple circuit and ease of assembly make it an excellent first project for the beginner—it *could* be completed in one evening.

First, cut a 4" x 12" perforated Masonite panel. Ream out two  $\frac{3}{8}$ " holes at the points shown here. Mount the speaker against the right side of the front panel, aligning it with a row of perforations. Then mark the speaker mounting holes to coincide with the panel perforations, and file or drill for proper installation of the mounting screws.

A 4" x 4" piece of cardboard is used as a small speaker baffle. Center the speaker over it and punch the mounting holes. A 3" circle should be cut out of the center of the cardboard for the speaker cone opening.

Mount the loudspeaker, baffle, and other components. The tube socket is mounted with a small bracket or by means of  $1\frac{1}{4}$ "-long 6-32 screws inserted through the panel.

The wiring sequence is: first the power supply, then the ground circuit, then the output transformer, and the remainder. Loopstick antenna coil *L1* must be provided with four turns of wire to serve as a tickler (*L2*). Use insulated wire, between No. 22 and No. 30, and leave  $2\frac{1}{2}$ " of lead on each end.

After winding the tickler, hold your soldering iron near (but not against) the coil till the wax flows slightly. This will hold the turns in place. The coil itself (*L1*, *L2*) can be mounted by soldering its slug screw retainer on the tube socket frame or bracket. The tickler connections should be made last. Solder them lightly because they may have to be interchanged.

Now install the tube, use a 3' to 5' length of wire for the antenna, and plug in the line cord.

With the volume control on full, rotate the tuning capacitor till a station or an oscillation squeal is heard. If there's no signal, or a weak one, connect a longer antenna and try again. If the set is still dead, place your finger on the center lead of the volume control (without making any other contact with your body). A loud hum should be heard. If it is not heard, check the audio stage. If you do get the hum, the difficulty is in the detector. In that case, try reversing the tickler coil connections to insure that they are wired correctly with relation to the primary.

Broadcast band coverage should be complete. If your set doesn't cover the entire broadcast range, adjust the screw slug in the Loopstick coil until it does.

If your radio played, but didn't oscillate, reverse the tickler coil connections (if you

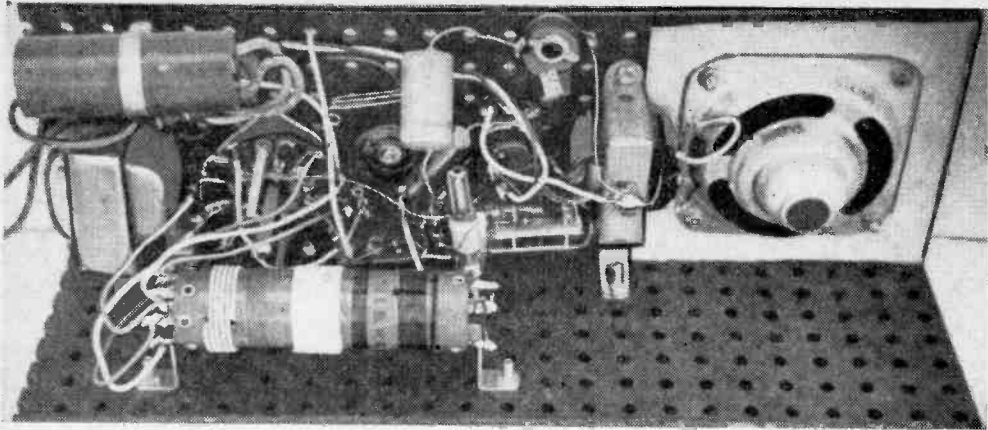

### how it works

The 12AU7 (V1) has two triode sections, one of which is used as a regenerative detector; the sensitivity and selectivity of this type of detector are obtained by feeding back a portion of the detector's output signal to the detector's input by way of tickler coil L2. Tube V1's second triode serves as an audio amplifier-output stage — its job is to amplify the audio signal which the preceding triode has separated from the radio-frequency signal. The power supply is a standard selenium rectifier type with RC filtering.

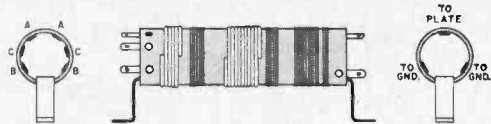

Parts placement is shown in rear view of Monoceiver at top of page. The multi-winding short-wave coil may be seen at left of center in photo. Connection details of this coil appear in diagram above.

haven't already done so). Leave the tickler connections fixed for loudest reception or oscillation. A squeal indicates that regeneration is excessive for the signal being received. Reducing the volume slightly or using a different length of antenna is the solution.

If you are close to stations, a very short antenna will pick them up, without causing a squeal, but you'll have a difficult time receiving weaker stations. A compromise can be achieved by the use of an adjustable antenna trimmer capacitor.

The trimmer capacitor is a variable type of about 50- $\mu$ fd. maximum capacitance. For strong stations that might cause oscillation, decrease the antenna coupling; for weaker stations, increase it.

Short-wave coverage and other features can be added to your receiver in about 30 minutes. With five turns of insulated antenna lead wrapped around the handle of a metal filing cabinet, the "Voice of the Andes" comes in at loudspeaker volume. With headphones, London and U. S. commercial short-wave and hams blast in loud and clear. And for the code-conscious, there's plenty of c.w.

The bandswitch knob is installed on the front panel next to the tuning capacitor. The

Layout of Monoceiver as straight broadcast receiver; placement of parts varies from s.w. model.

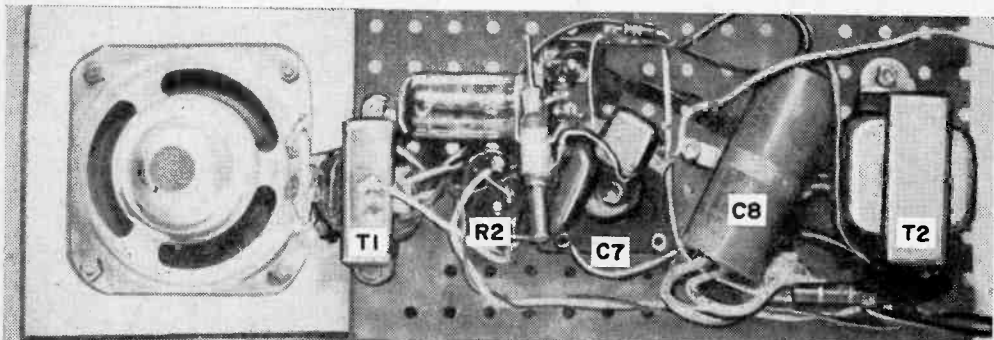



## parts list

C1—50- $\mu$ fd. trimmer capacitor  
 C2—250- $\mu$ fd. mica capacitor  
 C3—500- $\mu$ fd. ceramic capacitor  
 C4—0.01- $\mu$ fd., 200-volt capacitor  
 C5—1- $\mu$ fd., 200-volt paper capacitor  
 C6—35- $\mu$ fd. variable capacitor (Bud 1852)  
 C7—365- $\mu$ fd. tuning capacitor  
 C8a/C8b—30-50  $\mu$ fd., 150-volt electrolytic capacitor  
 J1—Phone jack  
 L1—Loopstick antenna coil (Lafayette MS11)  
 L2—Four turns of wire below L1 (see text)  
 L3, L4, L5, L6, L7, L8—Short-wave three-band antenna coil (Miller 511-SW-A)  
 R1—2.2-megohm,  $\frac{1}{2}$ -watt resistor  
 R2—50,000-ohm potentiometer

R3—470,000-ohm,  $\frac{1}{2}$ -watt resistor  
 R4—1-megohm volume control (with switch S2)  
 R5—47,000-ohm, 1-watt resistor  
 R6—4700-ohm, 1-watt resistor  
 R7—47-ohm,  $\frac{1}{2}$ -watt resistor  
 S1—2-pole, 4-throw bandswitch (Mallory 3234J)—one section not used  
 S2—S.p.s.t. switch (on R4)  
 SPKR.—3" loudspeaker  
 SR1—30-ma. selenium rectifier  
 T1—25,000- to 3.2-ohm output transformer  
 T2—Power transformer, 125-volt and 6.3-volt secondary (Stancor PS 8415)  
 V1—12AU7 tube  
 1—4" x 12" piece of perforated Masonite  
 Misc. knobs, terminal strips, line cord

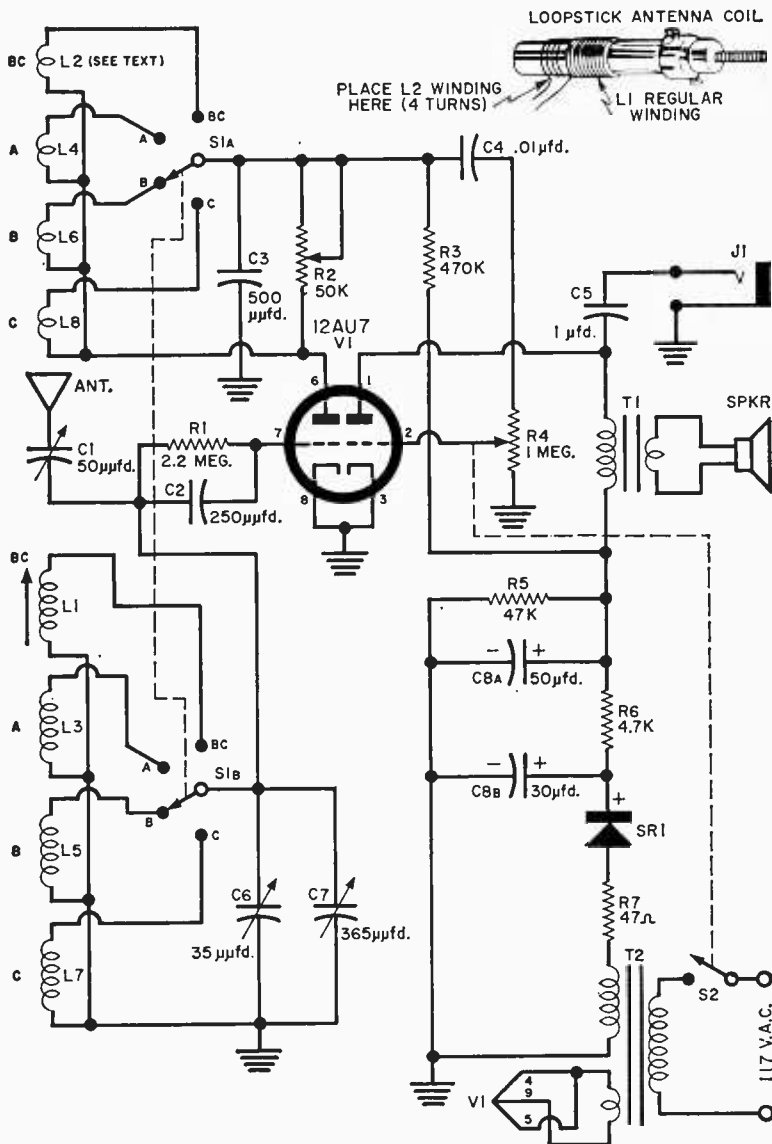



by  
Joseph W. Doherty  
K2SOO

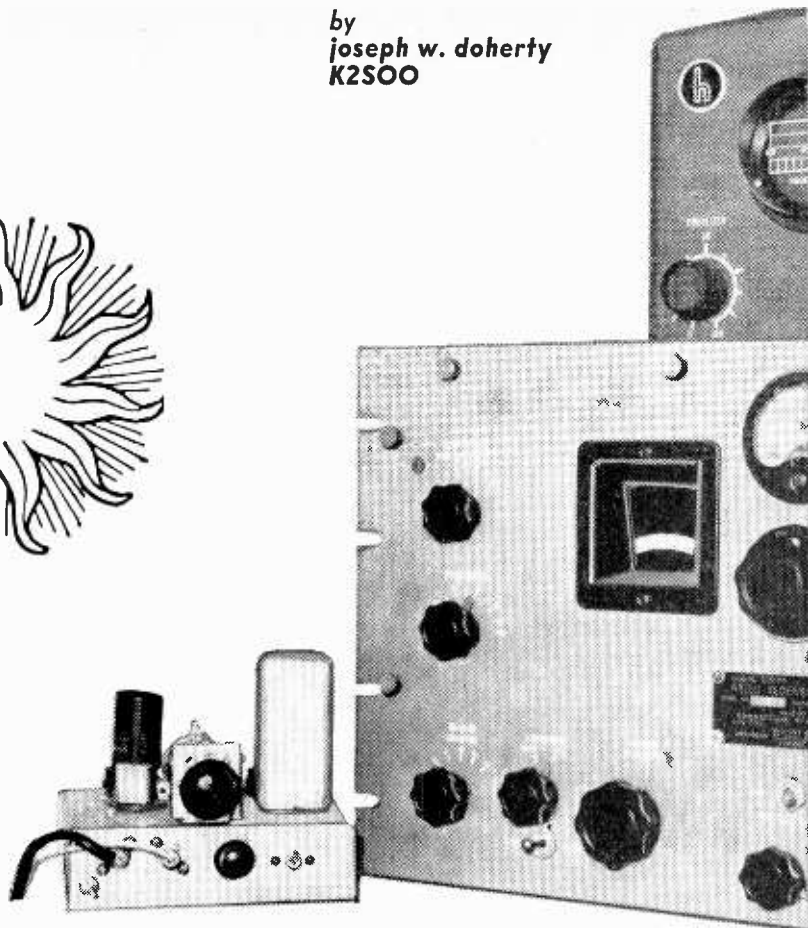
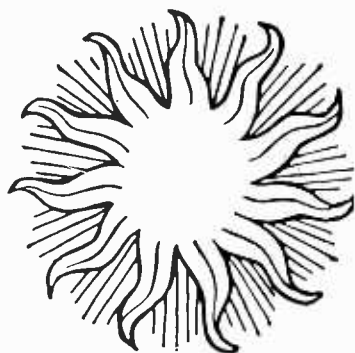

# converter for daytime dx

*how to extend the range of receivers that don't cover frequencies higher than 20 mc.*

Many a novice making his start in ham radio develops a yen for something more in the way of DX than is available on the 80- and 40-meter Novice bands, especially during daytime hours when DX is scarce. For the SWL or ham whose receiver lacks coverage of 15 meters, here is an inexpensive, easy-to-build converter which will introduce the owner to the many stations near this wavelength and which will add zest to the hobby.

This converter functions as a front end to a broadcast-band receiver that serves as a tunable i.f. amplifier. There are two sections to the converter: the oscillator-mixer stage incorporating the 6SA7 tube; and the beat-frequency oscillator (BFO) using a 6J5 tube.

The BFO enables you to hear continuous-wave (c.w.) or unmodulated signals by providing a beat-note for their reception. Its frequency is nearly the same as the intermediate frequency in the broadcast receiver, and it is variable so that the pitch of the audible beat-note produced by it can be varied. Because the i.f. of most broadcast receivers is 450-455 kc., the BFO must be designed to operate in the same region.

You can also use the converter with a communications receiver. If your receiver already has a BFO, this part of the converter unit can be eliminated.

Many older receivers do not include the 15-meter amateur band. We tried the converter with a National NC 101XA receiver, and used a 19.700-mc. crystal. When mixed with 21-mc. signals, this produced a difference frequency range which fell into the unused 160-meter band on the receiver with excellent results.

### construction

Input coil *L1* consists of a B & W Miniductor #3011 or the equivalent ( $\frac{3}{4}$ " diameter, 16 turns per inch) using a total of 21 turns. Ground one end of the coil to the chassis and connect the other end to the signal grid of the 6SA7 tube and capacitor *C1*.

Connect the antenna wire (about 9' long) directly to the coil at a point three to four turns up from the ground end of the coil. This point provides the best average impedance match for the antenna, consistent with good tuning characteristics for the antenna trimmer capacitor *C1*, and good sensitivity over the entire 15-meter band.

Output coil *L2* is a Vari-Loopstick and should be tuned to approximately 1200 kc., as will be explained later. The oscillator plate tank consists of *C8* and *L4*.

BFO coil *L3* is commercially available at most radio supply houses. *S1* is the BFO "on-off" switch. The BFO output is coupled via *C7* to the filament lead at the terminal strip to simplify coupling to the receiver i.f. amplifier circuit. In so doing, it has been assumed that power for the converter will be taken from the receiver power supply. If this is not the case, the BFO output can be introduced to the receiver via a separate lead loosely coupled to the i.f. amplifier or second-detector circuits.

In constructing the converter, one precaution should be taken. Locate the input circuit (*L1* and *C1*) away from the oscillator tank circuit (*L4*, *C8*), and away from the output coil (*L2*). Note that the input coil and capacitor are mounted on top of the chassis and the two other coils are underneath and spaced from one another.

The crystal required might not be available locally. However, it can be ordered by mail from any of several crystal manufacturing companies. The one in the model cost \$3. Order the crystal before you begin construction so that you will have it when you need it.

### operation

When connecting the converter to the receiver, it will be necessary to disconnect the antenna lead from the receiver and connect it to the converter input. Connect the converter output to the antenna post on the receiver, using a short shielded wire to prevent stray broadcast pickup.

Power for the converter can be taken from the receiver or a separate power supply. The unit takes 6 volts for filament, 150-250 volts d.c. for plate supply. Because of shock hazard, connection to an a.c./d.c. receiver is not recommended unless an isolation transformer is used between the receiver and power line.

Turn on the receiver and, after it has warmed up, adjust *C1* for maximum signal. Then adjust *L2* for maximum signal strength with the receiver tuning dial set at approximately 1200 kc., the mid-point of the desired frequency band.

Tune across the receiver dial. You should hear lots of activity at dial settings from 1000 kc. through 1400 kc. If you do not, first check antenna trimmer *C1* for maximum signal strength, then check the oscillator circuit.

### troubleshooting

If removing the crystal has no effect on what you hear, the oscillator is not functioning. Replace the crystal and check *L4*, the slug-tuned oscillator plate coil. This must be adjusted to provide the proper impedance for the oscillator plate circuit. Misadjustment of the slug will cause the oscillator to cease functioning, and the converter will not operate.

The adjustment is not critical, however, and once properly made need not be done again. It should be turned about halfway in for stable operation.

## how it works

Incoming signals are introduced through L1, C1 to the signal grid of the 6SA7 mixer tube. L1 and C1 are tuned to the frequency of the desired signal in the 21-mc. region. The input circuit functions best with a single-wire antenna about 8' or 9' long. The antenna connects to a point four turns up from the grounded end of L1. This point provides adequate sensitivity without greatly sacrificing selectivity.

Output of the crystal oscillator is combined with the signal frequency in the mixer tube and the difference between the two is the signal at the intermediate frequency

which appears in the plate circuit of the 6SA7.

If the converter is to operate ahead of a broadcast receiver, the i.f. output must fall within the broadcast band. The signal frequency for the 15-meter band is from 21,000 through 21,450 mc. Operating the crystal oscillator at 20 mc. provides a difference i.f. of 1000 kc. with an input signal frequency of 21 mc.

With an input signal of 21.450 mc., the difference frequency is 1450 kc. Therefore, the broadcast receiver dial is tuned from 1000 kc. (the center of the broadcast band) for 21 mc. and to 1450 kc. for 21.450 mc.

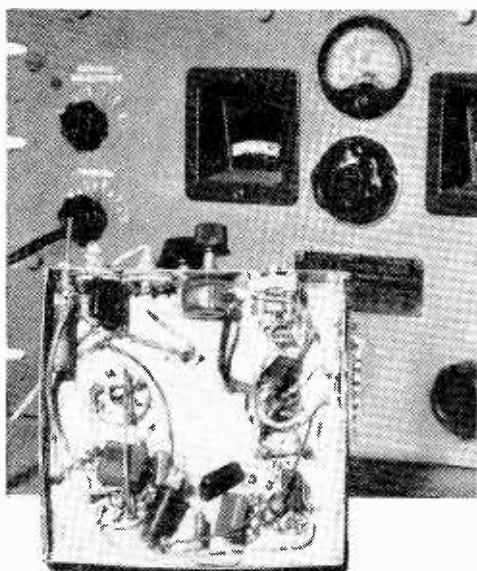
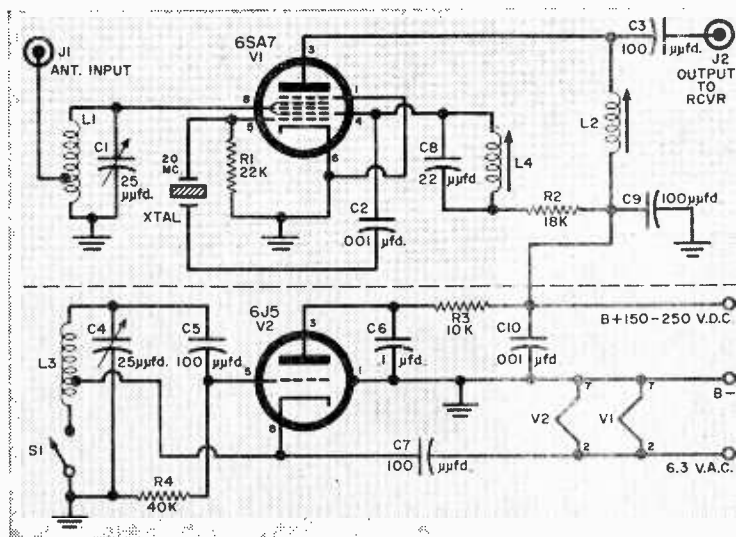

When the unit is connected to extend the frequency range of a communications receiver, the 6J5 BFO tube should be omitted.

### parts list

- C1, C4—25- $\mu$ fd. variable air padder capacitor
- C2, C10—0.001- $\mu$ fd. mica capacitor
- C3, C5, C7, C9—100- $\mu$ fd. mica capacitor
- C6—0.1- $\mu$ fd., 600-volt paper capacitor
- C8—22- $\mu$ fd. mica capacitor
- J1, J2—Miniature phono jack with ceramic center insulator (General Cement #H-667-F)
- L1—B & W Miniductor coil #3011 (see text)
- L2—Superec Vari-Loopstick
- L3—BFO transformer (Meissner #17-6753 or equivalent)
- L4—18 turns close-wound #18 enameled wire on  $\frac{3}{8}$ " slug tuned coil form
- R1—22,000-ohm,  $\frac{1}{2}$ -watt resistor
- R2—18,000-ohm,  $\frac{1}{2}$ -watt resistor
- R3—10,000-ohm,  $\frac{1}{2}$ -watt resistor
- R4—40,000-ohm,  $\frac{1}{2}$ -watt resistor
- S1—BFO "on-off" switch
- V1—6SA7 tube
- V2—6J5 tube
- Xtal—20-mc., third overtone crystal (International Crystal or equivalent)
- 1—Octal ceramic socket for crystal



# Conelrad Your Home

*all of us should use a receiver that warns*

*when the conelrad alert begins*

*by i. c. chapel*

Want a Conelrad alarm receiver that is self-contained and doesn't require a connection to your AM or FM receiver? A receiver that needs a minimum of maintenance (if any), with the exception of a battery check? Well, here's one that's hard to beat. It has nine parts (costing about \$8.00), requires a minimum current drain from batteries and is "fail-safe" in operation.

As most readers know, the first step in a Conelrad alert is shutting off the transmitter of all AM, FM and TV broadcasting stations. This period of inactivity lasts for five seconds and is followed by a similar five-second period with the carrier on (without programming), and then another five-second "carrier-off" period. This is followed by a tone and a message about the alert, with the station finally shutting down.\*

The unit to be described gives an alarm when a pre-tuned broadcast signal stops. It uses transistors in a very efficient circuit and a small number of parts. At the author's location, the unit is tuned to broadcast station KPH and, in the event that the radio-frequency carrier is stopped for any reason, the alarm buzzer will operate.

## circuit details

The only special component in the alarm circuit is a modified ferrite rod antenna coil ( $L1$ ). This is reworked by unwinding 20 turns from the coil and twisting the wire at the spot where it leaves the form to make a tap. Rewind the wire on the coil after the tap has been made. Remove the insulation from the tap.

\* Except stations on 640 and 1240 kc. Obviously, in building an alarm unit it is not a good idea to tune it to either of these channels. Although they will observe the five-second warning periods, there will be stations on these frequencies at all times during the air raid.

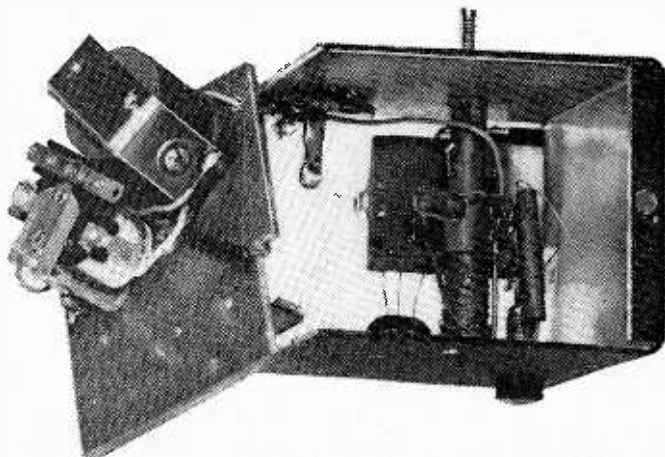

Location of parts is shown in the photo. Use of larger "D" cells instead of the penlite cells specified would provide more power for the buzzer and longer life but would require a bigger cabinet.



# BUILD YOUR OWN RADIO

## CIRCUITS AT HOME ONLY

with the New Deluxe 1959  
**PROGRESSIVE RADIO "EDU-KIT"®** \$22.95

- A Practical Home Radio Course**
- Now Includes**
- ★ **TRANSMITTER**
  - ★ **SIGNAL TRACER**
  - ★ **SIGNAL INJECTOR**
  - ★ **CODE OSCILLATOR**
  - ★ **No Knowledge of Radio Necessary**
  - ★ **No Additional Parts or Tools Needed**
  - ★ **EXCELLENT BACKGROUND FOR TV**
  - ★ **School Inquiries Invited**
  - ★ **Sold In 79 Countries**

**YOU DON'T HAVE TO SPEND HUNDREDS OF DOLLARS FOR A RADIO COURSE**

The "Edu-Kit" offers you an outstanding PRACTICAL HOME RADIO COURSE at a rock-bottom price. Our Kit is designed to train Radio & Electronics Technicians, making use of the most modern methods of home training. You will learn radio theory, construction practice and servicing. THIS IS A COMPLETE RADIO COURSE IN EVERY DETAIL. You will learn how to build radios, using regular schematics; how to wire and solder in a professional manner; how to service radios. You will work with the standard type of punched metal chassis as well as the latest development of Printed Circuit chassis. You will learn the basic principles of radio. You will construct, study and work with RF and AF amplifiers and oscillators, detectors, rectifiers, test equipment. You will learn and practice code, using the Progressive Code Oscillator. You will learn and practice trouble-shooting, using the Progressive Signal Tracer, Progressive Signal Injector, Progressive Dynamic Radio & Electronics Tester and the accompanying instructional material. You will receive training for the Novice, Technician and General Classes of F.C.C. Radio Amateur License. You will build 16 Receiver, Transmitter, Code Oscillator, Signal Tracer and Signal Injector circuits, and learn how to operate them. You will receive an excellent background for Television, Hi-Fi and Electronics. Absolutely no previous knowledge of radio or science is required. The "Edu-Kit" is the product of many years of teaching and engineering experience. The "Edu-Kit" will provide you with a basic education in Electronics and Radio, worth many times the complete price of \$22.95. The Signal Tracer alone is worth more than the price of the entire Kit.

### THE KIT FOR EVERYONE

You do not need the slightest background in radio or science. Whether you are interested in Radio & Electronics because you want an interesting hobby, a well paying business or a job with a future, you will find the "Edu-Kit" a worth-while investment. Many thousands of individuals of all

ages and backgrounds have successfully used the "Edu-Kit" in more than 79 countries of the world. The "Edu-Kit" has been carefully designed, step by step, so that you cannot make a mistake. The "Edu-Kit" allows you to teach yourself at your own rate. No instructor is necessary.

### PROGRESSIVE TEACHING METHOD

The Progressive Radio "Edu-Kit" is the foremost educational radio kit in the world, and is universally accepted as the standard in the field of electronics training. The "Edu-Kit" uses the modern educational principle of "Learn by Doing." Therefore you construct, learn schematics, study theory, practice trouble-shooting—all in a closely integrated program designed to provide an easily-learned, thorough and interesting background in radio. You begin by examining the various radio parts of the "Edu-Kit." You then learn the function, theory and wiring of these parts. Then you build a simple radio. With this first set you will enjoy listening to regular broadcast stations, learn theory, practice testing and trouble-shooting. Then you build a more advanced radio, learn more advanced theory and techniques. Gradually, in a progressive manner, and at your own rate, you will find yourself building more advanced multi-tube radio circuits, and doing work like a professional Radio Technician. Included in the "Edu-Kit" course are sixteen Receiver, Transmitter, Code Oscillator, Signal Tracer and Signal Injector circuits. These are not unprofessional "breadboard" experiments, but genuine radio circuits, constructed by means of professional wiring and soldering on metal chassis, plus the new method of radio construction known as "Printed Circuitry." These circuits operate on your regular AC or DC house current.

### THE "EDU-KIT" IS COMPLETE

You will receive all parts and instructions necessary to build 16 different radio and electronics circuits, each guaranteed to operate. Our Kits contain tubes, tube sockets, variable, electrolytic, mica, ceramic and paper dielectric condensers, resistors, tie strips, coils, hardware, tubing, punched metal chassis, Instruction Manuals, hook-up wire, solder, etc. In addition, you receive Printed Circuit materials, including Printed Circuit chassis, special tube sets, hardware and instructions. You also receive a useful set of tools, a professional electric soldering iron, and a self-powered Dynamic Radio and Electronics Tester. The "Edu-Kit" also includes Code Instructions and the Progressive Code Oscillator, in addition to F.C.C.-type Questions and Answers for Radio Amateur License training. You will also receive lessons for servicing with the Progressive Signal Tracer and the Progressive Signal Injector, a High Fidelity Guide and a Quiz Book. You receive Membership in Radio-TV Club. Free Consultation Service, Certificate of Merit and Discount Privileges. You receive all parts, tools, instructions, etc. Everything is yours to keep.

### PRINTED CIRCUITRY

At no increase in price, the "Edu-Kit" now includes Printed Circuitry. You build a Printed Circuit Signal Injector, a unique servicing instrument that can detect many Radio and TV troubles. This revolutionary new technique of radio construction is now becoming popular in commercial radio and TV sets. A Printed Circuit is a special Insulated chassis on which has been deposited a conducting material which takes the place of wiring. The various parts are merely plugged in and soldered to terminals. Printed Circuitry is the basis of modern Automation Electronics. A knowledge of this subject is a necessity today for anyone interested in Electronics.

### UNCONDITIONAL MONEY-BACK GUARANTEE

**ORDER DIRECT FROM AD—RECEIVE FREE BONUS RESISTOR AND CONDENSER KITS WORTH \$7**

- Send "Edu-Kit" postpaid. I enclose full payment of \$22.95.
- Send "Edu-Kit" C.O.D. I will pay \$22.95 plus postage.
- Rush me FREE descriptive literature concerning "Edu-Kit."

Name .....  
Address .....

**PROGRESSIVE "EDU-KITS" INC.**  
1186 Broadway, Dept. 503RR, Hewlett, N. Y.

### FREE EXTRAS

- **SET OF TOOLS**
- **SOLDERING IRON**
- **ELECTRONICS TESTER**
- **PLIERS-CUTTERS**
- **ALIGNMENT TOOL**
- **WRENCH SET**
- **VALUABLE DISCOUNT CARD**
- **CERTIFICATE OF MERIT**
- **TESTER INSTRUCTION MANUAL**
- **HIGH FIDELITY GUIDE & QUIZZES**
- **TELEVISION BOOK & RADIO TROUBLE-SHOOTING BOOK**
- **MEMBERSHIP IN RADIO-TV CLUB: CONSULTATION SERVICE, FCC AMATEUR LICENSE TRAINING**
- **PRINTED CIRCUITRY**

### SERVICING LESSONS

You will learn trouble-shooting and servicing in a progressive manner. You will practice repairs on the sets that you construct and will learn symptoms and causes of trouble in home, portable and car radios. You will learn how to use the professional Signal Tracer, the unique Signal Injector and the dynamic Radio & Electronics Tester. While you are learning in this practical way, you will be able to do many a repair job for your friends and neighbors, and charge fees which will far exceed the price of the "Edu-Kit." Our Consultation Service will help you with any technical problems you may have. J. Stataitis, of 25 Poplar Pl., Waterbury, Conn., writes: "I have repaired several sets for my friends, and made money. The "Edu-Kit" paid for itself. I was ready to spend \$240 for a Course, but I found your ad and sent for your Kit."

### FROM OUR MAIL BAG

Ben Waterloo, P. O. Box 21, Magna, Utah: "The Edu-Kits are wonderful. Here I am sending you the questions and also the answers for them. I have been in the radio for the last seven years, but like to work with Radio Kits, and like to build Radio Testing Equipment. I enjoyed every minute I worked with the different kits; the Signal Tracer works fine. Also like to let you know that I feel proud of becoming a member of your Radio-TV Club." Robert L. Shuff, 1534 Monroe Ave., Huntington, W. Va.: "Thought I would drop you a few lines to say that I received my Edu-Kit, and was really amazed that such a bargain can be had at such a low price. I have already started repairing radios and phonographs. My friends were really surprised to see me get into the swing of it so quickly. The 'Troubleshooting Tester' that comes with the Kit is really swell, and finds the trouble, if there is any to be found."

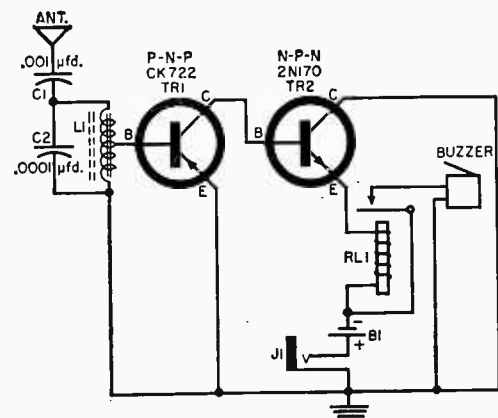

## parts list

- B1—Three 1½-volt penlite cells in series
- C1—0.001- $\mu$ fd. mica capacitor
- C2—0.0001- $\mu$ fd. mica capacitor
- J1—Phone jack and plug
- L1—Ferrite rod antenna coil
- RL1—1000-ohm relay (Sigma 4F)
- TR1—CK722 transistor
- TR2—2N170 transistor
- 1—2" x 2¾" x 2¾" metal box
- 1—6-volt buzzer (see text)
- 1—Phono jack for antenna

## how it works

The tuned circuit, L1/C2, is set to an AM broadcast station whose radio-frequency carrier is strong enough to change the bias on TR2. Current is drawn through relay RL1 and keeps the armature pulled in to open the relay contacts. When the broadcast carrier is interrupted, the contacts close, completing the circuit through the buzzer.

The electronic part of the unit consists of the tuned circuit and the two transistors. The antenna is connected through an isolation capacitor, value of which is not critical. A value of 0.001  $\mu$ fd. was used by the author with a ten-foot length of wire. A longer antenna will be required if the nearest station is distant. As with any antenna, the main thing is to locate it in a position so that it will pick up maximum r.f. signal for the job.

Use a CK722 for the detector transistor. Or, if more sensitivity is desired, use a CK768. Both are of the *p-n-p* type. The collector of this transistor is connected directly to the base of the second transistor, a 2N170 *n-p-n* type.

The relay is a Sigma 1000-ohm type with single-pole double-throw contacts. Only the back contacts, which are normally closed, are used in this hookup. The spring tension is adjusted so that a current of about 6 ma. will pull in the armature and open these contacts.

Any interruption of the current will allow the contacts to return to the normally closed position. When this happens, the battery furnishes power to the buzzer and it warns that the pre-tuned broadcast carrier wave is off the air.

The buzzer can be made from another relay, by connecting its back contacts in a circuit that makes and breaks when power is supplied. During testing of this alarm, it was noted that, in addition to the noise produced by the buzzer itself, there was enough static radiated from the buzzer to make a noise in a nearby receiver. Of course, this happens only when the alarm is sounding and not during the standby period. This noise, caused by the contacts of the buzzer, would be helpful if the operator were wearing headphones while using his receiver.

## installation

After the unit is wired and ready for operation, connect it to an antenna ten or more feet long and a good ground. Leave the buzzer disconnected. Plug in earphones and adjust the slug in coil L1 to the loudest local station. If the signal is sufficiently strong, the relay armature should pull in. Remove the phone plug and insert in its place a plug having both terminals connected together by a piece of wire. The buzzer can now be connected, and the setup is complete. To test, disconnect the antenna and see if the buzzer operates.

Opening of the battery circuit to both the buzzer and the transistors is taken care of by removing the shorting plug from J1. Just leave the plug out when the unit is not in use.

**EDITOR'S NOTE:** The current of 6 ma. reported by the author of the above article amazed us. Upon investigation, however, we concluded that his location must be fairly close to the broadcast station, perhaps within a mile of the antenna. One of our editors built a duplicate alarm unit and tried it out at his home about 35 miles from the high-power stations around New York City. None of these stations provided enough signal strength to operate the relay specified. An 8000-ohm relay was substituted with no better results. Using this more sensitive relay, however, gave promise of proper operation from a 250-watt station ten miles away. Using an antenna length of 150 feet, the alarm worked perfectly. We suggest plugging in a 0.5 ma. meter, if one is available, to determine whether the current output is sufficient at your location and with your antenna to actuate the relay properly.

## section V

### electronic games to play

build the quizzomat	<b>102</b>
got the shakes?	<b>105</b>
liven up the party with a "warmth meter"	<b>108</b>
win at nim with debicon	<b>110</b>
catch the vanishing ball	<b>115</b>
compute with pots	<b>119</b>
check your marksmanship with bullets of light	<b>122</b>
play games with nixie tubes	<b>126</b>



# I.Q.



## Build the Quizzomat

by harvey pollack

The popularity of radio and television quiz programs proves that people like to answer questions, especially if there is a reward for the right answer. The "QUIZZOMAT" is designed for your home quiz program—with built-in "cheat-catcher" and "suspense" circuits to hold interest and make it valuable as a testing machine as well as a game.

### how to play

A typed or handwritten sheet of true-false questions is placed on the QUIZZOMAT panel. Each of the questions has a corresponding toggle switch and a neon lamp. The player moves each switch to the right or left to indicate his answer—"True" or "False"—for each question. During the test no indication is given of the correctness of the answers.

When all questions have been answered, the push button labeled *Hold Down To Score (S13)* is depressed. A buzzer sounds, but *none of the scoring lights glow*. After S13 is held down about five seconds, the buzzer cuts out and the scoring panel springs to life. Correct answers are indicated by lit lamps, wrong answers are shown by dead ones.

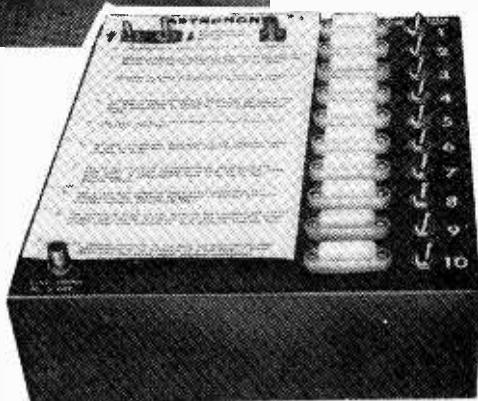



Code Switch Position	↑↑	↓↑	↓↓	↑↓
Answers that will light the scoring lamps	1 false	2 false	3 true	4 true
	5 true	6 false	7 true	8 false
	9 true	10 false		

With the wiring as shown below, answers in table above are for each of the four code switch positions.

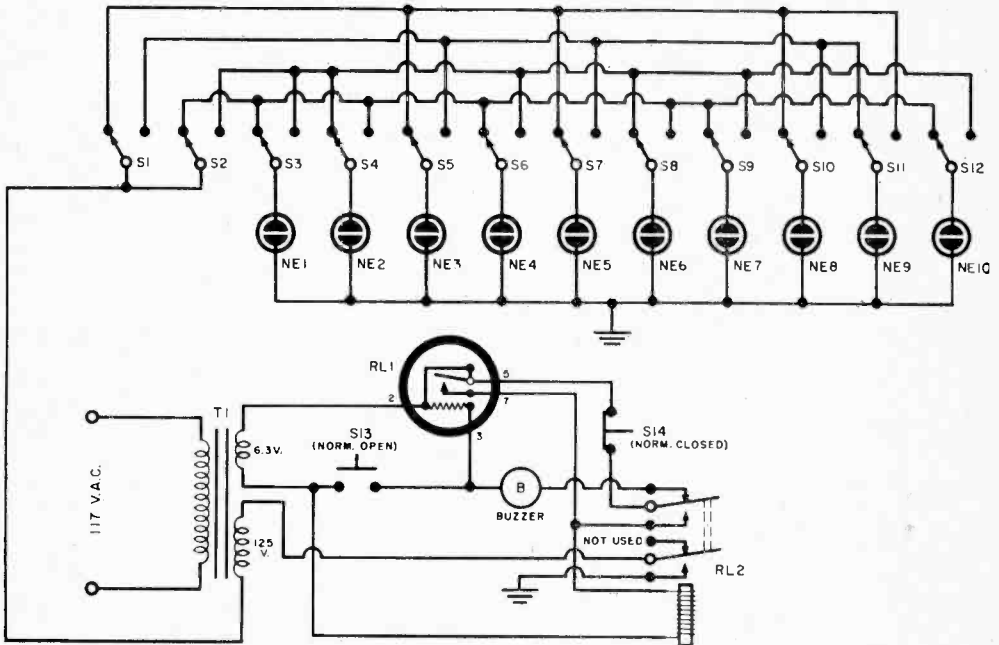

### parts list

- NE1 through NE10—Neon light assembly (Drake Type 110 Flushlite or NE-2—see text)  
 RL1—Thermal-time delay relay, 6.3-volt heater, 5-second delay (Amperite 6N05)  
 RL2—6.3-volt a.c., d.p.d.t. relay (Guardian Coil Assembly 200-6A, Contact Assembly 200-2)  
 S1 through S12—S.p.d.t. toggle switch  
 S13—Push-button switch, normally open (Hart & Hegeman 3391E or Olson Radio Warehouse SW-109 wired as above)  
 S14—Push-button switch, normally closed (Hart and Hegeman 3391 or Olson Radio Warehouse SW-109 wired as above)  
 T1—Power transformer, 6.3-volt @ 0.6-amp. and 125-volt @ 15-ma. secondary (Stancor PS8415 or equivalent)  
 1—10" x 12" x 3" aluminum chassis (Bud AC-413)  
 2—Brass spacers, 1" long, to pass 6-32 screw  
 1—Octal socket  
 1—6-volt a.c. buzzer (E. F. Johnson Co., No. 114-400 or equivalent)  
 Misc. hardware, solder lugs, wire, etc.

The scoring lamps will remain latched-in until you are ready to start a new question series. To do so, press the *Push to Reset* button (14) and the QUIZZOMAT is restored to its original condition.

The buzzer and time delay arrangement does two things. It prevents the player from pressing the scoring button and sneaking a look to see how he's doing. And the waiting interval between pressing the scoring button and the appearance of the final score adds a bit of suspense that multiplies the fun.

Can the right sequence of true and false

answers be memorized? Not a chance. Each series of questions carries a code in the form of two arrows which instructs the player how to set the two toggle switches (S1 and S2) at the upper left corner of the panel before he begins. These switches "program" the QUIZZOMAT to accept a particular set of true-false answers for each test.

### construction details

A 10"x12"x3" aluminum chassis is used for the foundation of the game. Along its right side, drill a series of ten holes for the s.p.d.t. answer switches. The neon signal lights are mounted to the left of each switch.

If Flushlite lamps are used, you will need two  $\frac{5}{16}$ " terminal openings in addition to the

## how it works

As each answer switch is operated, it either connects or disconnects one terminal of the associated neon lamp to one terminal of the 125-volt secondary of transformer T1. The other terminal of the neon tube is connected to chassis at all times, but the opposite end of the 125-volt secondary is open since relay RL2 is not activated until the scoring button is held down for the proper interval.

When the scoring push button (S13) is pressed and held down, current flows into the heater of the thermal delay relay (RL1), causing the bi-metallic armature to bend toward the contact slowly. After about five seconds, contact is made between the armature (terminal 5 on the octal socket) and the contact point (terminal 7 on the octal socket). During this delay, 6.3 volts are fed to the buzzer, causing it to sound continuously. (This feature may be eliminated at the constructor's option.)

As soon as contact is established in RL1, the 6.3-volt winding of T1 is connected to the coil of RL2. When RL2 closes, the buzzer circuit is broken and the neon lights corresponding to the correct answers are turned on. RL2 stays closed since its upper contacts bridge the thermal relay and the coil of RL2 remains energized. The scoring lights will therefore stay lit when S13 is released. The scoring tally can then be made and noted for later reference.

To reset the system, S14 is depressed. This releases RL2. The lights go out, and a new answer sequence can be selected by using a new topic sheet and resetting S1 and S2 as per the code arrows.

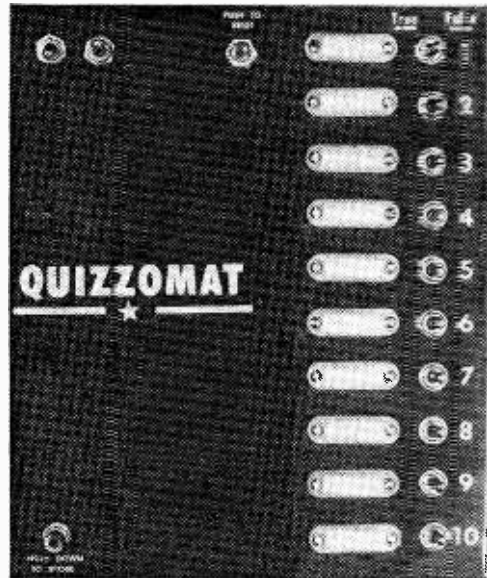

Quizzomat front panel above shows the parts layout to be followed. The two switches on the upper left side of the panel set the "programming" which determines the "right" and "wrong" sequences for each topic sheet. Note that the timing and scoring circuit components are mounted on the inside aprons of the chassis box (below).

mounting screws. NE-2 neon lamps may be substituted, held in place by grommets in  $\frac{1}{2}$ " holes, and connected into the appropriate circuits by soldering directly to their leads. Each NE-2 must have a 47,000-ohm,  $\frac{1}{2}$ -watt resistor in series with it. Flushlites have these resistors built in.

The thermal time-delay relay, (RL1), 6-volt a.c. relay (RL2), buzzer, and transformer T1—are secured to the rear and side aprons of the chassis.

One terminal of each neon lamp should be grounded directly to the chassis by connecting it to a solder lug held by one of the Flushlite mounting screws.

Wire the answer switches and neon lamps first, then the buzzer and time-delay circuits. The octal socket of RL1 is held above the chassis apron by two  $1\frac{1}{2}$ " 6-32 screws which pass through two 1" brass spacers.

A good true-false quiz should have a random selection of answers. The switch and code wiring chosen provides four different groups, which vary enough to prevent memorization. With the wiring as shown in the diagram, the answers are given on page 103 for each code-switch position.

When composing a series of ten quiz questions, select the sequence code upon which it is to be based, then make up the questions so that the correct answers follow the true-false sequence of the chosen code.

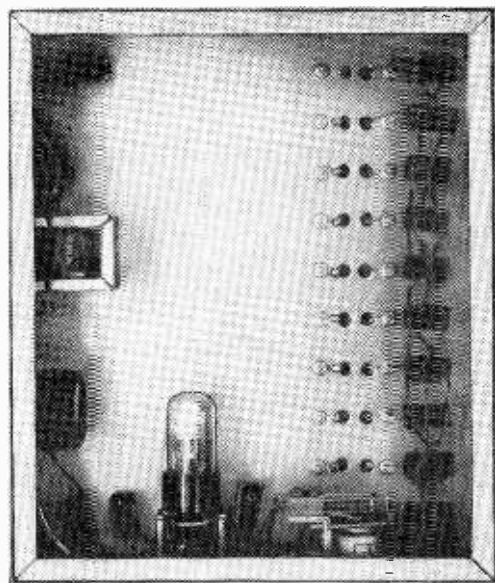



got the  
**Shakes?**

by **harvey pollack**

In the days of the Golden West, Wild Bill Hiccup and Fearful Fosdick used to gauge their gun-hand steadiness by pouring a glass of whiskey through a knothole—at arm's length. Nowadays, we can do much the same thing, electronically. The gadget to be described here will save a lot of spilled liquid and is considerably more accurate. One like it is actually used to test "steadiness" by some police and accident prevention authorities.

There's nothing to stop you from using this gadget at a party if you want to—as an "ice breaker." Your guests are sure to flock around to see who has those nerves of iron, so popular (and necessary) in the bygone days.

#### **test yourself**

After you turn on the switch, a short time delay occurs—adjustable from three to fifteen seconds. Then the indicator light will go on. To test yourself, sit in front of the panel with the prod in hand. Touch the tip of the prod to the *touch plate* at the top of the panel. The indicator light will click off and the timing interval of about eight seconds will begin. (Set timing control for this interval.)

*build this transistorized  
gauge to test the steadiness  
of your hands and  
those of your friends*

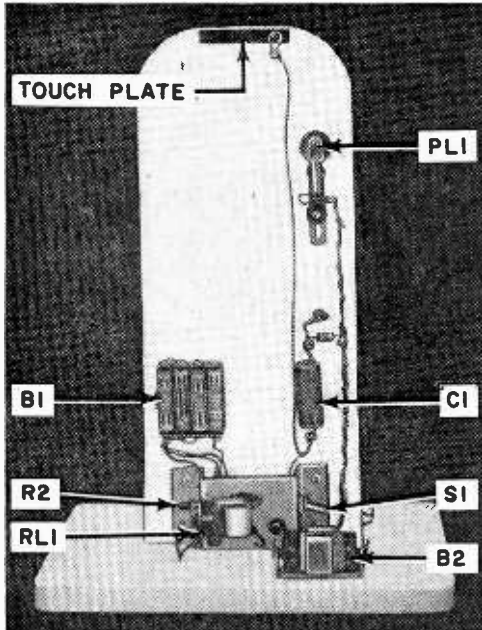

Rear view of tester shows sub-assemblies and the touch plate on back of wooden uprights.

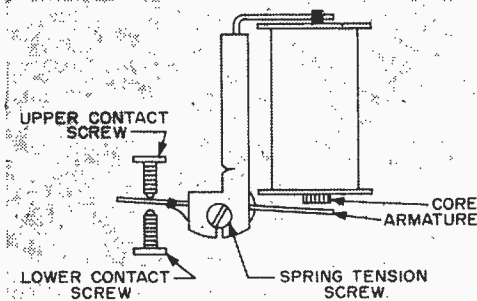

Contact and tension screws of the relay, sketched above, will need some adjustment. See text.

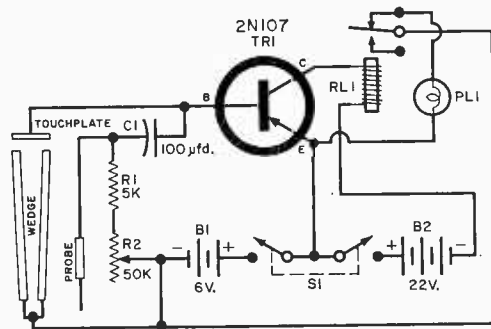

Note wiring of wedge strips and touch plate in schematic. These are basic parts of the circuit.

As quickly as your steadiness permits, move the prod tip down the middle of the wedge, trying not to touch the sides. The briefest contact will turn on the indicator light and it will remain glowing even if the contact is broken. If the sides of the wedge are not touched but more than the allowed time is used, the timing circuit will automatically trip the indicator light on. In either case, the score is determined by the numbers at the side of the track.

sum of three trials	rating	score
40-48	Excellent	A
30-39	Above average	B
20-29	Average	C
10-19	Below average	D
0-9	Poor	E

You can use this scoring system with the tester or, if you wish, you can develop your own system.

### construction hints

When fastening the metal wedge strips in place, start the gap at about  $\frac{3}{8}$ " at the top and let it narrow down to  $\frac{1}{8}$ " at the bottom. The touch plate is insulated from the vertical wedge strips and fastened to the uprights by short wood screws with a solder lug under one of them. Drill two #26 holes near the lower edge of the wedge strips and mount them with long 6-32 machine screws. Add a solder lug to each.

The power switch (S1), the timing potentiometer (R2), and the transistor socket all require subchassis wiring. A small aluminum chassis can be constructed or a little shelf of wood will do as well. All three

### parts list

- B1—Four 1.5-volt batteries (Burgess #7 or equivalent)
  - B2—22.5-volt miniature battery (RCA VS084)
  - C1—100- $\mu$ fd, 25-volt capacitor (Mallory 2501 or equivalent)
  - PL1—Pilot light assembly for #47 bulb
  - R1—5000-ohm,  $\frac{1}{2}$ -watt resistor
  - R2—50,000-ohm potentiometer (Mallory U-34 or equivalent)
  - RL1—8000-ohm relay (Sigma 4F or equivalent)
  - S1—D.p.s.t. toggle switch
  - TR1—Type 2N107 transistor (General Electric)
  - 1—Battery holder for VS084 (Lafayette MS177 or equivalent)
  - 1—Battery holder for four #7 cells (Acme #4)
  - 1—Test probe and wire lead
  - 1—2" metal-strap touch plate
  - 2—Metal wedge strips (see text)
- Cost of parts, approx. \$11.00

components and the relay (*RL1*) should be mounted with their connections easily available for soldering.

The two battery holders are secured to the wood members by small wood screws. Be *VERY CAREFUL* to observe correct polarity when inserting the batteries. Even *momentary* reversal of polarity may ruin the transistor.

### adjustment

After wiring is complete, rotate *R2* fully clockwise (shortest interval). At the instant power is applied, the indicator light should flash on briefly. Relay *RL1* must now be carefully adjusted by manipulating the contact and spring tension screws. If the light remains on, it means that relay spring tension is too great. Turn the adjusting screw slightly counterclockwise.

Before turning power on, always touch the prod tip to the *touch plate* to discharge *C1*. Repeat the above procedure until the light flashes every time the power switch is operated.

With *RL1* working dependably, allow the timing circuit to operate. After five or ten seconds, the indicator light should flash on automatically. If too long a period passes, or it does not flash, give the lower contact screw a very tiny clockwise adjustment—no more than 1/20 of a turn.

Test the control that *R2* exercises over the circuit. The range should be from three seconds at one end of rotation to about 15 seconds at the other end. Careful adjustment of the relay contact screws takes care of the timing range.

### how it works

The collector current of a transistor depends upon the base current, among other things. When power is applied, a small charging current flows into the timing capacitor (*C1*) through the base circuit, making the collector current large enough to hold relay *RL1* in. As the capacitor charges, the base current—and consequently the collector current—decreases slowly until it can no longer hold in the relay armature. The time required for the capacitor to charge is controlled by the resistance of the timing potentiometer (*R2*) in series with it.

When the probe touches the touch plate, capacitor *C1* is short-circuited and a new timing period starts. If the wedge strips are touched by the probe during this interval, the timing resistors (*R1*, *R2*) are short-circuited, charging the capacitor almost instantaneously. The base current drops to zero, the collector current diminishes to its lowest value, and the relay armature is released again.

## Save Half ASSEMBLING ONE OF THESE TWO

*Schober*

## ELECTRONIC ORGANS in KIT form

"CONCERT" "CONSOLETTA"



NO SPECIAL SKILLS  
PAY KIT-BY-KIT

CONSOLETTA MODEL  
Occupies only 2' x 3'2"  
Floor Space

- HANDSOME ASSEMBLED CONSOLES
  - DOUBLE KEYBOARDS — 122 KEYS
  - ABOVE-KEYBOARD TABS
  - CONCERT MODEL CONFORMS TO A G O SPECIFICATIONS. Occupies 3'5" x 4'7" Floor Space
  - BUILT-IN SPEAKERS OPTIONAL (For Console Model only)
  - COMPLETE DETAILED INSTRUCTIONS
  - FREE—NEW 1959 EDITION of 16-page BOOKLET DESCRIBING BOTH MODELS
  - 10" LP RECORD DEMONSTRATING BOTH MODELS available for \$2, refundable on receipt of order
- Write today—see what fine instruments you can have at such great savings.

The **SCHOBERS ORGAN CORP.**  
2248-H Broadway, New York 24, New York

## WILL EMPLOYMENT RISE?

It certainly will! Our growing country means growing needs—for new schools, homes, roads, goods and services. Meeting these needs of America will call for *22 million new jobs* in the next 15 years. To get more facts about *your* great future, write today for a free illustrated booklet to: THE ADVERTISING COUNCIL, Box 10, Midtown Station, New York 17, N. Y.

by james a. mc roberts

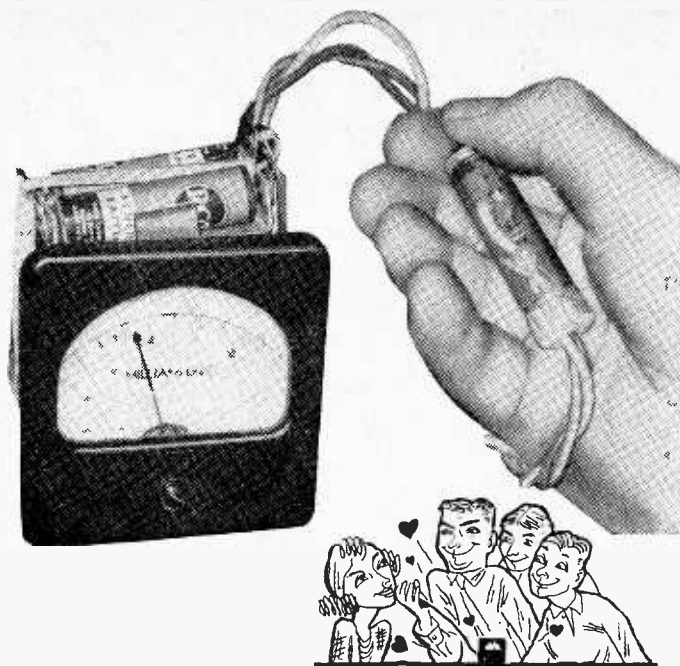

## **Liven Up That Party...**

### **With a "Warmth Meter"**

When the small talk has dropped, the refreshments have run low, and you're biting your nails to think of some way to pep up your party, drag out the "Warmth Meter." It's guaranteed to put sparkle into that get-together. Handled properly, it is also possible that this inexpensive little device can build up your reputation as a Casanova in modern dress.

Most of the parts, except the transistor and its socket, will probably be available in your junk box. Meter *M1* is a standard 0-1 ma. d.c. type. The two penlight cells (*B1*) snap into their holder in place of a switch, although you can add a switch if you wish. As you can see from the schematic on page 109, the circuit is quite simple.

#### **it shows warmth**

The transistor changes resistance when it is heated by fingers held against it. More collector current flows, which can be interpreted as the 'warmth' or 'lovability' of an individual. The meter reading will increase slowly since the G.E. 2N107 has a thermal lag of about 10 seconds to applied body heat.

Good thermal contact with the transistor shell will raise the reading from 0.25 ma. to about 0.6 ma. at normal room temperature. The rise will vary with the individual. It will drop back slowly when the hand is removed.

Transistor *TR 1* is housed on the end of its own shipping case, a plastic tube. The base resistor (*R1*) and transistor socket are mounted in the plastic tube, as well as the 100,-

*a single transistor measures  
the temperature  
of your guests' hands . . .  
with a gimmick!*

000-ohm resistor ( $R_2$ ). The latter resistor and a lead from the base extend to two contacts on the side of the plastic case.

### there's a gimmick

By shunting these two contacts, the meter reading can be increased considerably over that otherwise obtained. The shunt may be the fingers (which would be kept secret from the uninitiated, of course). Slyly moistening the fingers can make the meter needle practically jump off scale. Thus, someone in the know can prove visibly that he is a very "hot" individual.

Possible overload damage to transistor, meter, or both, is prevented by series resistor  $R_2$ . Maximum current through the meter will be less than 3 ma., which will not damage it unless unduly prolonged. For positive protection of the meter, you can put about 1500 ohms in series with it, although this has not been found necessary.

If you wish, the two shunting contacts on the plastic case may be made far less conspicuous, or less easily touched. One might

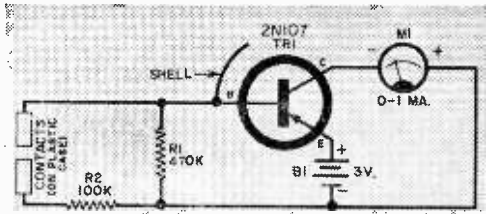

### parts list

- B1—2 penlight cells
- R1—470,000-ohm resistor
- R2—100,000-ohm resistor
- TR1—Transistor (G.E. 2N107 or equivalent)
- 1—Transistor socket
- 1—Plastic transistor case (or equivalent pill holder)

be at the wire entrance hole, for example. The other contact going to the base of the transistor can be omitted. You can simply scrape a little paint off the shell of the transistor since its shell is internally grounded to the base. Touching the contact connected to minus (through the resistor) and the bare spot on the transistor shell will have the same effect as shunting the two contacts of the gimmicked "warmth meter."

## DEPENDABLE TV-RADIO TUBES



1-YEAR GUARANTEE

**ZALYTRON** Tubes for TV-Radio Servicemen, Dealers, Experimenters.

Nationally sold ZALYTRON Tubes are BRAND NEW Quality Tubes, priced low to help you meet competition in your area — and guaranteed to perform as well and as long as tubes much higher priced. Why pay more? Try them once, you'll buy them always. Every tube we ship is covered by our Full Refund Guarantee . . . YOU be the judge! Send today for new Price List "HB"

## BE YOUR OWN BOSS

### RUN A SELF-SERVICE TUBE BUSINESS

# FREE

Get This Modern Sturdy Tube Tester

with "Package Deal" order for nationally sold ZALYTRON Quality Brand Receiving Tubes. We'll show you how to start a successful Tube Tester Route, and get YOUR share of today's Big Profits in Self-Service Tube Sales! This is no "Get-Rich-Quick" scheme but a solid, proven business that will reward you well — if you WORK at it. But, INVESTIGATE before you INVEST! Get full details on the best "Deal" now being offered, send today for our booklet "H"



**ZALYTRON** TUBE CORPORATION  
220 West 42nd St., N. Y. 36, N. Y.

## Technical Instruction in RADAR TV MICROWAVES RADIO BROADCASTING COMPUTERS

School-owned, Student-operated Station WPWT-FM  
School Catalogue "PH" sent on request.

### PHILADELPHIA WIRELESS TECHNICAL INSTITUTE

1533 PINE STREET  
A Non-profit Corporation

PHILADELPHIA 2, PENNA.  
Founded 1908

by harvey pollack



Although the game of "NIM" has been popular for literally hundreds of years, most of the people who play it are not aware that it can be analyzed by a mathematical system. If you are handy with *binary* numbers, you can win every time. Operating with binary numbers mentally, however, is a trick that is not easy to master.

The "DEBICON" (DEnary-BIinary-CON-verter) does all the hard work for you. When you learn to interpret the mathematical code of its flashing light panel—it's easy once you know the rules—you can beat the best "brain" among your friends every time you play.

The fun of DEBICON is the challenge it offers your opponent to make use of the lights in the same manner you do; but just let him try to make sense of their changing patterns!

#### **the game itself**

To see how the DEBICON is used, let's do a quick rundown on the rules that govern the four-number version of NIM. This form of the game is more fun to play than the

## ***Win at*** **NIM** ***with*** **DEBICON**

*play this old game with  
modern switching circuits  
instead of matches*



simpler varieties and is much more mystifying to your friends when you force a win.

Two players are involved. One of them sets out four piles of matches, toothpicks or coins, the number in each pile not to exceed ten. Fewer than ten objects may be used in any of the piles, but it's more fun to start with larger amounts. Instead of using coins or matches, the game can be played by setting the four numbered dials on the DEBICON.

Assume that player X has set out matchsticks as in Table 1. Pile A contains nine sticks, pile B seven, pile C three, and pile D six. Player Y is now allowed to remove any number or all sticks from any *one* pile. Let's suppose he takes seven from pile A. Then, player X takes two from pile B while player Y takes all the remaining sticks from pile A on his next turn. The progression of the complete game might run somewhat as shown in Table I. Each time a player's turn comes up, he is allowed to operate on only one pile at a time, and the person who is left holding the last stick loses the game. In our sample game, player X is left holding the last one—the one in pile C. Player X is the loser.

### doing it electronically

When NIM is played on the DEBICON, the piles are reduced by rotating the selected knobs from higher to lower numbers. Each player takes his turn and works one knob at a time. As each knob is twisted, the row of four horizontal lights fluctuates in pattern for each new setting. If you're the player that knows the "code," at your turn you simply reset one of the knobs in accord with the secret instructions flashed to you by the panel of lights.

Each time it is your turn to play, you reduce the setting of *one* of the knobs until each of the vertical columns has an even number of lit lamps. Zero (or no lamps lit) is "even," as are the numbers "two" and "four." You are now "safe" and your opponent is stuck. His next move will invariably change the pattern so that one or more of the columns will add up to an *odd* number. At your turn, you can re-establish a safe condition by resetting the appropriate dial for an "even" sum of glowing lamps.

Table 2 shows the complete sequence of moves for player X and player Y applied to the example given previously. Player Y is "in the know," and player X, sometimes called

Steps	Pile A	Pile B	Pile C	Pile D
Player X sets matchsticks out this way	////////	//////	///	//////
Player Y takes seven from Pile A, leaving two sticks	//	//////	///	//////
Player X takes two from Pile B, leaving five sticks	//	////	///	//////
Player Y takes the remaining two from Pile A, leaving none in this particular pile		////	///	//////
Player X takes all from Pile D, leaving none in this pile		////	///	
Player Y takes two from Pile B, leaving three sticks		///	///	
Player X takes all of Pile B, leaving none in this pile; the only sticks left now are three in Pile C			///	
Player Y takes two from Pile C, leaving only one; Player X loses, being stuck with last stick			/	

Table 1. This is how two people might play the game of NIM using matchsticks.

Steps	4 3 2 1	Result
Player X sets up the numbers this way: 9 7 3 6	A 9 → ○ ○ ○ ● B 7 → ○ ● ● ● ● C 3 → ○ ○ ● ● ● D 6 → ○ ● ● ○ ○	Columns 1, 2 and 4 have odd totals: UNSAFE
Player Y takes seven from Pile A, leaving two sticks in this pile: 2 7 3 6	A 2 → ○ ○ ● ● ○ B 7 → ○ ● ● ● ● C 3 → ○ ○ ● ● ● D 6 → ○ ● ● ○ ○	All columns now total even (2, 4, 2): SAFE
Player X takes two from Pile B, leaving five sticks in this pile: 2 5 3 6	A 2 → ○ ○ ● ● ○ B 5 → ○ ● ● ● ● C 3 → ○ ○ ● ● ● D 6 → ○ ● ● ○ ○	Column 2 is now odd again (3): UNSAFE
Player Y takes the remaining two from Pile A, leaving none in this pile: 0 5 3 6	A 0 → ○ ○ ○ ○ ○ B 5 → ○ ● ● ● ● C 3 → ○ ○ ● ● ● D 6 → ○ ● ● ○ ○	All columns again total even (2, 2, 2): SAFE
Player X takes all from Pile D, leaving none in this pile: 0 5 3 0	A 0 → ○ ○ ○ ○ ○ B 5 → ○ ● ● ● ● C 3 → ○ ○ ● ● ● D 0 → ○ ○ ○ ○ ○	Columns 2 and 3 now are odd (1, 1): UNSAFE
Player Y takes two from Pile B, leaving three sticks here: 0 3 3 0	A 0 → ○ ○ ○ ○ ○ B 3 → ○ ○ ● ● ● C 3 → ○ ○ ● ● ● D 0 → ○ ○ ○ ○ ○	Totals again even (2 and 2): SAFE
Player X takes all of pile B, leaving none in this pile; what remains is: 0 0 3 0	A 0 → ○ ○ ○ ○ ○ B 0 → ○ ○ ○ ○ ○ C 3 → ○ ○ ● ● ● D 0 → ○ ○ ○ ○ ○	Both columns odd (1 each): UNSAFE
Player Y takes two from Pile C, leaving only one; Player X loses, being left with last stick: 0 0 1 0	A 0 → ○ ○ ○ ○ ○ B 0 → ○ ○ ○ ○ ○ C 1 → ○ ○ ○ ● ○ D 0 → ○ ○ ○ ○ ○	End of game

Table 2. Using the secret code with DEBICON insures your winning the game.

"sucker," is doomed! Once player Y acquires the "knack" of interpretation, he is unbeatable.

There is one exception to the even-sum rule but since it occurs only at end-game it should cause no trouble. As you approach end-game, you must not leave an even number of "ones" on the *dials* of the DEBICON as the only remaining digits. Should the game happen to proceed toward this end result, adjust your last move so that three "ones" or a single "one" remain on the board. If your last move should leave your opponent with two "ones" or four "ones," he can wipe you out by removing a single "one" each time his turn comes around, forcing you to pick up the last.

### constructing the DEBICON

Locate the holes for the rotary switch shafts with plenty of clearance between adjacent wafers. Since all the finished switches are exact duplicates of one another, they can

be prewired in identical fashion before installation. Wire color-coded leads about eight inches long from interconnected terminals for later connection to the indicator lamps. Each colored wire should be identified by associating it with a specific pilot lamp. Record this association to make your final connections easier.

Position "zero" and all subsequent positions are determined as follows. Remove the shaft nut from the switch. This will free the adjustable stop which should be removed and discarded. Turn the switch shaft fully *counterclockwise* and observe where the wiping contact comes to rest. This is the zero position. The next clockwise step is position one, then two, and so on.

Drill 16  $\frac{1}{2}$ " holes in the front panel for the indicator lamps, forming a square of four vertical columns and four horizontal rows. Insert a  $\frac{1}{2}$ "-o.d.,  $\frac{3}{8}$ "-i.d. *soft* rubber grommet in each hole, moisten the pilot lamps and press them in place gently for a friction fit. With the lamps installed, join their metal shells by spot-soldering one continuous piece of bare, tinned hookup wire to each one in turn. Then connect the end of this jumper wire to either terminal of the 6.3-volt transformer secondary.

Before mounting the individual switches, connect their wiper-contact terminals together with the same type of bare wire and ground the end of each jumper to the case. The remaining 6-volt transformer secondary lead is also grounded, completing the circuit to the individual lamps through the appropriate switch contacts.

**Decals** provide lettering for the switch positions and for the pilot lamps.

**Wiring** of one of the four rotary switches and one of the horizontal rows of lamps is shown below, right. The other three switches are wired exactly the same and each handles one horizontal row of lamps. Switches connect together only at common ground as shown.

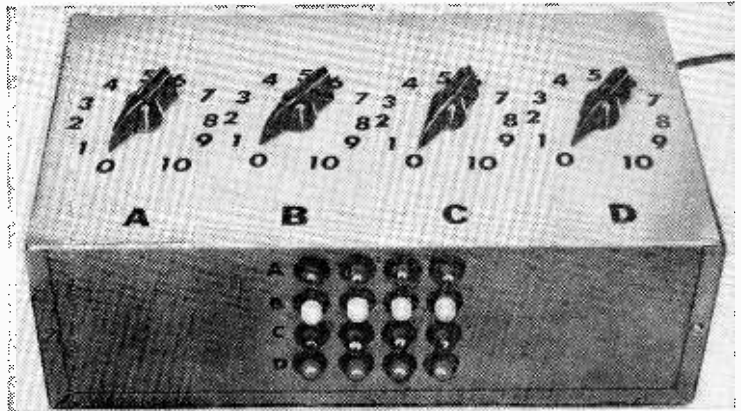

### how it works

The wiring of the DEBICON selector switches is arranged to set up the **denary** numbers from zero to ten in binary form. The game of NIM is based on the binary number system in which it may be shown that "even" digital totals in the columns—regardless of the number of columns—establish a "safe" condition. When any **one** of the numbers is altered, the condition becomes "unsafe."

In other words, it is not possible to go from a set of "even" columnar totals to a second set of "even" totals by resetting only one of the switches; hence, the play must oscillate from "safe" to "unsafe" on each successive move. As long as a player repeatedly restores the even totals, his opponent must set up odd totals in at least one of the columns on every move. This eventually results in the opponent being left with the last "one"—and he's lost the game!

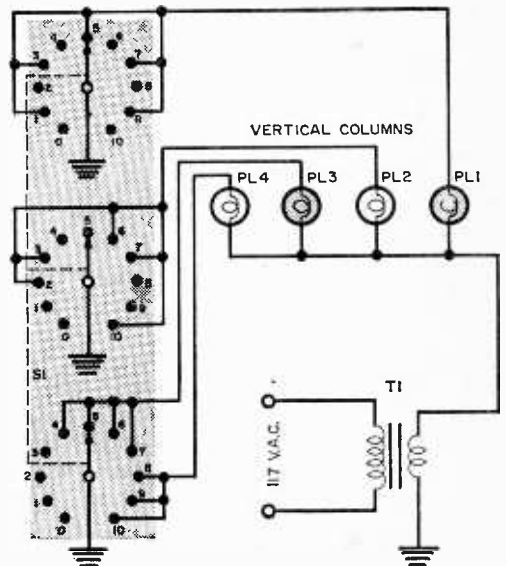

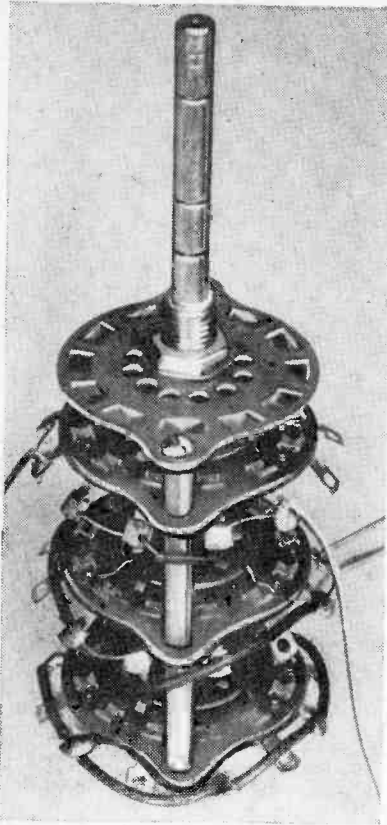

Close-up above shows wiring of one three-deck switch.

Use care when soldering to base contacts of lamps.

Step	Light Sequence			
0	0	0	0	0
1	0	0	0	*
2	0	0	*	0
3	0	0	*	*
4	0	*	0	0
5	0	*	0	*
6	0	*	*	0
7	0	*	*	*
8	*	0	0	0
9	*	0	0	*
10	*	0	*	0

0=Light OFF; \*=Light ON

Table 3. If the wiring is correct, lamps will light as shown at switch positions.

Each of the four color-coded leads coming from the switches is now connected to the associated base solder contact on each of the pilot lamps. Since each set of connections to horizontal rows A, B, C, and D is identical, only one set is shown in the diagram.

After completing the wiring for the first switch and the first horizontal row, set the switch on the zero position and plug the unit into a convenient 117-volt a.c. receptacle. Rotate the switch clockwise step-by-step as you observe the sequence of glow, and com-

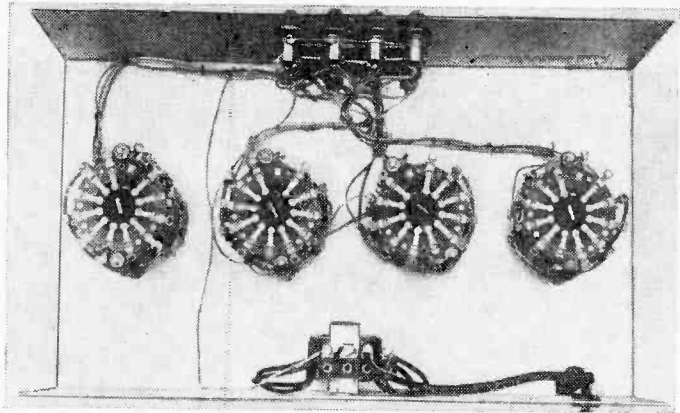

#### parts list

- PL1 to PL16—6.3-volt pilot lamp with bayonet base (#47)
- S1, S2, S3, S4—3-circuit, 3-section, 11-position rotary switch (Mallory 1331L)
- T1—6.3-volt filament transformer, 1 amp. secondary
- 1—7" x 12" x 4" Minibox (Bud CU-2111)
- Misc. decals, grommets, line cord, terminal strip and colored hookup wire

pare the steps with those given in Table 3.

Be sure that neither leg of the a.c. line is accidentally grounded to the case. The *only* power lead which should be connected to the case is one of the 6-volt secondary transformer leads.

The numbers and lettering shown in the illustrations were applied by means of alphabet decals.

by harvey pollack



# Catch the Vanishing Ball

Wooden cabinet conceals electronic and mechanical components. Dimensions of cabinet are not critical.

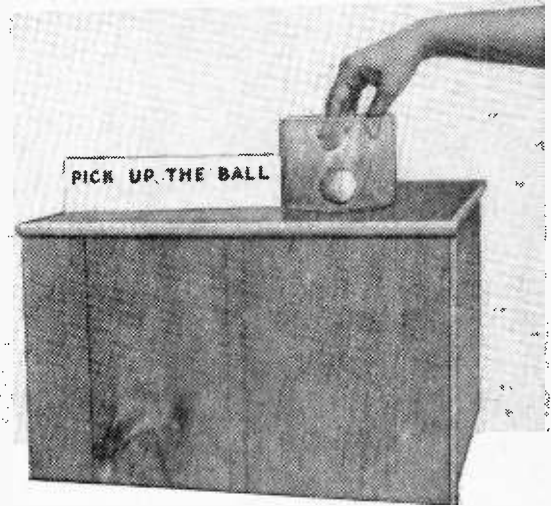

This proximity-activated ping-pong ball is guaranteed to startle and amuse young and old alike. It sits quietly on its little box—sits quietly, that is, until a grasping hand approaches, and then—PLOP it's gone! When the hand is withdrawn, the ball reappears. It's as simple as that, and the small cost of construction will more than be compensated for by the delight of the youngsters and the mystification of adults.

The mechanical section can be built first. Start by cutting a 3" circle out of the top panel. The center of the circle is midway between the two long sides of the panel, 5½" from either short side. If a good circle cutter is carefully used, the cutout disc can later serve as the ping-pong ball platform.

Wind the solenoid coil on a commercially available coil form. After the Bakelite capping squares have been cemented in place and allowed to dry, wind on the enameled magnet wire. Use a B & S gauge (between #34 and #40).

If the coil form is chucked on a 2" bolt, and you use your electric drill to wind it, you'll find that it goes very fast. Since the coil should measure about 400 ohms, wind several hundred turns, check the resistance, then continue until the ohmmeter shows that you've arrived. If no ohmmeter is available, try about 1000 feet of #36 wire. Scramble-winding works just as well as any other kind, so you needn't be fussy.

Cut and assemble the wood parts as shown. Drill the iron armature ¼" from one end to take a 6-32 1" machine screw. Correct alignment of the lever and lever posts is essential for smooth action. Cement the return stop block along the circumference of the disc platform to prevent the platform from swinging above the panel.

The last step in the mechanical construction is the adjustment of the return elastic band. See photo for details of its placement.

With the panel assembly complete, the table side walls may be cut and secured to the top panel. To test the action, connect the coil leads to a 117-volt line cord through a

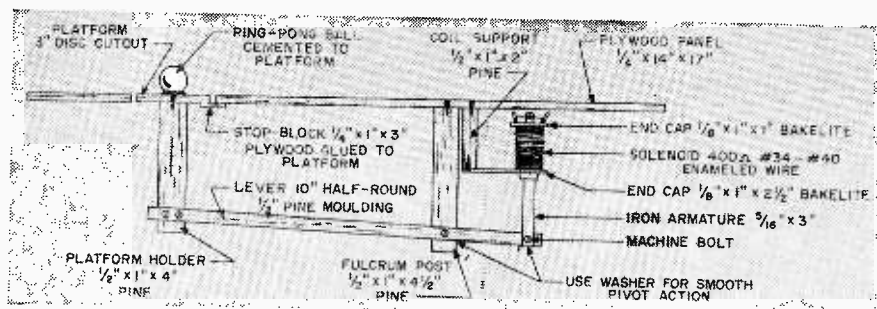

The mechanical assembly is shown at right (upside down) and in the drawing above (right side up). Rubber band which returns platform to the "up" position should be adjusted carefully. See text for details.

switch. Each time power is applied, the ball platform should drop at least three inches; the return should be smooth and accurate when power is removed.

The electronic construction is not very critical but certain mounting and wiring precautions should be observed for sensitivity and stability. Keep stray capacitance between the probe or sensor connection and the ground at a minimum! Careful isolation of the sensitivity control and rigidity of component mounting are important. The layout shown should be followed as closely as possible.

Variable capacitor  $C_2$  is secured to the chassis by means of its built-in mounting bracket. Set it as far back from the front panel as possible with its shaft connected by a  $\frac{1}{4}$ " to  $\frac{1}{4}$ " metal coupling and a  $\frac{1}{4}$ " Bakelite rod long enough to pass through the front panel bearing. Homemade coil  $L_1$  mounts on the rear apron of the chassis with its tuning slug projecting through the back of the case.

Three adjustable clips which come with the coil form are set in place and 50 turns of #40 enameled wire are wound between either end clip and the center one. A center-tap connection is made to the middle clip, and another 50 turns are added between the center and the remaining clip.

Make sure that the mounting of the remaining parts does not interfere with the free action of variable capacitor  $C_2$ . It is important that the wire connecting to the probe terminal be kept clear of other leads. Check the polarity of the crystal diode ( $CR_1$ ) and electrolytic capacitor  $C_7$ .

Adjust the relay by setting  $R_1$  fully clockwise (wiper farthest from ground) and  $C_1$  at minimum capacitance. Screw the coil slug about half-way in. Connect a wire from the probe terminal to any point on the screening material under the ball panel. Apply power and allow about 30 seconds for warm-up; during this interval you will hear the relay click in as the d.c. amplifier portion of the 6SL7 begins to draw current through the relay coil.

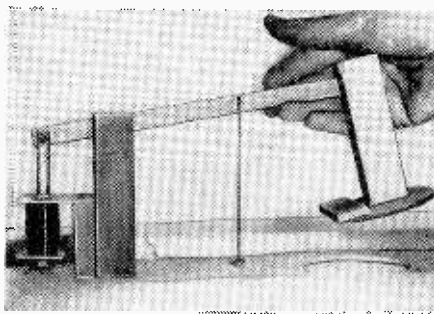

### bill of materials

- 1—17" x 14" section of  $\frac{1}{2}$ " plywood (top panel)
- 2—6" x 17" x  $\frac{3}{4}$ " lengths of pine (1 each for back and front panel)
- 2—6" x 12 $\frac{1}{2}$ " x  $\frac{3}{4}$ " lengths of pine (1 for each side)
- 1—1" x 1" x  $\frac{1}{2}$ " piece of fir or pine (cut to dimensions given in drawing, for three support posts)
- 1—1" x 3" x  $\frac{1}{4}$ " piece of plywood (stop block)
- 1— $\frac{1}{2}$ " half-round molding, 10" long (lever)
- 1—2" x  $\frac{1}{2}$ " paper base phenolic coil form for solenoid (Cambridge Type LS-4)
- 1—Roll of #34 to #40 enameled magnet wire
- 1—3" length of round iron stock,  $\frac{3}{16}$ " in diameter (curtain rod iron)
- 1—Piece of aluminum screening, approx. 2 sq. ft.
- 2—4" long x  $\frac{1}{4}$ " wide sections of Bakelite (coil end caps)
- Misc. rubber band, wood screws, etc.



Rear and interior views of relay assembly. Front panel, not shown, mounts sensitivity control and pilot lamp. Note insulated shaft extension and panel bearing used with frequency-adjusting capacitor C2.

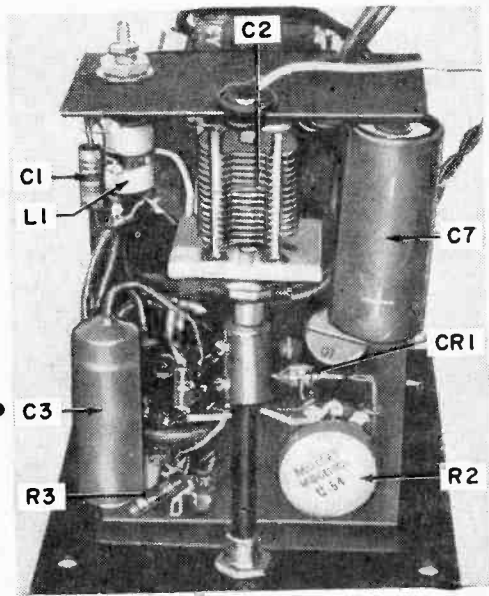

Pictorial diagram of the unit. Mounting lugs of the two-terminal tie points are used as circuit grounds and must make good chassis connection.

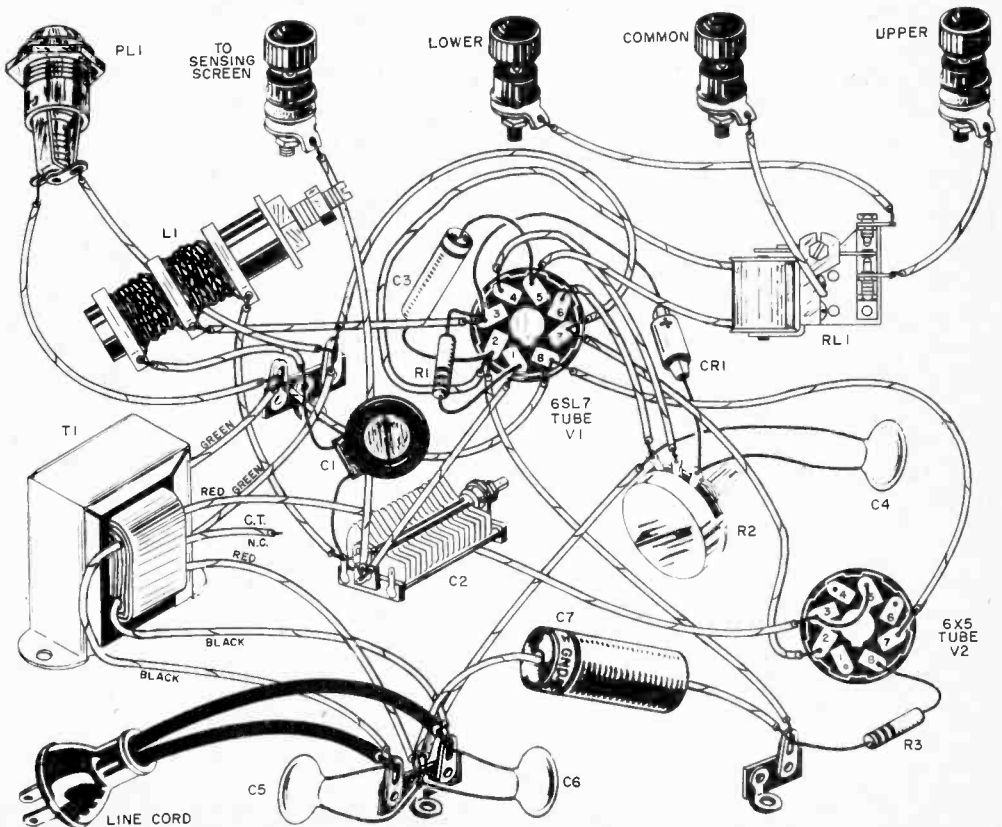

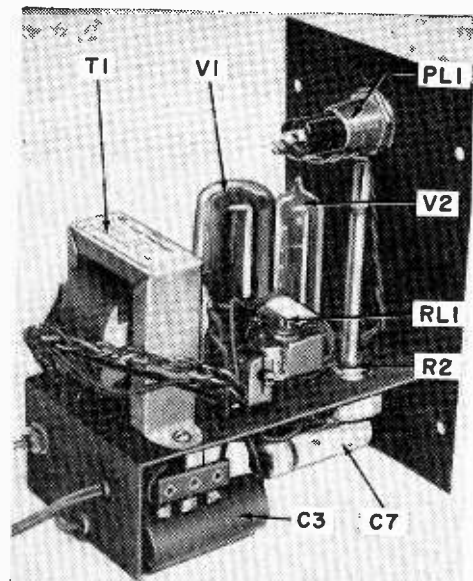

After installation, potentiometer R2 is adjusted through hole in cabinet top. Note use of half-wave rectifier in proximity relay schematic at right.

### how it works

The left-hand 6SL7 triode in a Hartley oscillator using C1 as a coupling capacitor. C1 is also part of a voltage divider; the probe-to-ground capacitance forms the second part.

With no grounded object near the probe sensor, the probe-to-ground capacitance is quite small while C1 is relatively large. Most of the r.f. energy from the L1 tank circuit is therefore applied to the grid of the oscillator. The large r.f. voltage which appears at the cathode of the oscillator tube is rectified by the crystal diode and applied as negative bias to the grid of the d.c. amplifier 6SL7 section through control R1. This bias keeps the plate current of the right-hand part of the tube well below the pull-in point of the relay.

Should a grounded body come into the vicinity of the probe screen, the effective probe-to-ground capacitance increases, causing a voltage-radio change which bypasses more of the r.f. to ground. The rectified voltage from the diode therefore decreases, the grid of the d.c. amplifier becomes less negative, and increasing the plate current energizes the relay. R1 determines the fraction of the voltage applied to the d.c. amplifier as bias and is used as a fine adjustment.

Now slowly rotate C1 toward maximum capacitance. At some point in the rotation, the relay will release. Then R1 should be adjusted until the relay just operates, and rotated back until it releases again.

When a hand is brought within six inches of the screen cylinder, the relay should pull in. If it remains latched when the hand is removed, back R1 off slightly and try again. With careful adjustment of C1 and R1, reliable sensitivity will be obtained for distances of about one foot. Now the leads from the ball solenoid should be connected in series with the relay contact binding posts (*Lower and Common*) and the a.c. line cord.

### parts list

- C1—100- $\mu$ fd. ceramic capacitor
- C2—100- $\mu$ fd.,  $\frac{1}{4}$ "-shaft variable capacitor (Hammarlund HF-100)
- C3—0.5- $\mu$ fd., 400-volt capacitor
- C4, C5, C6—0.01- $\mu$ fd., 600-volt disc capacitor
- C7—50- $\mu$ fd., 350-volt electrolytic capacitor
- CR1—1N34A or CK705 germanium diode
- L1—Coil form, slug-tuned, with movable clips (Cambridge LS-3)
- PL1—6.3-volt pilot light assembly
- R1—10-megohm,  $\frac{1}{2}$ -watt resistor
- R2—1-megohm linear taper potentiometer
- R3—2200-ohm,  $\frac{1}{2}$ -watt resistor
- RL1—8000-ohm relay (Sigma 4F or equivalent)
- T1—Power transformer; secondary, 125-0-125 volts at 25 ma., 6.3 volts at 1 ampere (Stancor PS8416)
- V1—6SL7 tube
- V2—6X5 tube
- 1—4" x 5" x 6" miniature cabinet, black crackle steel, with built-in chassis (ICA 3819)
- 4—Five-way binding posts
- 1—Coupler,  $\frac{1}{4}$ " to  $\frac{1}{4}$ " shafts
- 1—Phenolic extension rod, 6" long,  $\frac{1}{4}$ " in diameter
- 1—Panel bearing for  $\frac{1}{4}$ " shaft
- Misc. #40 wire for coil, decals, tube sockets, hardware, line cord, hookup wire, etc.

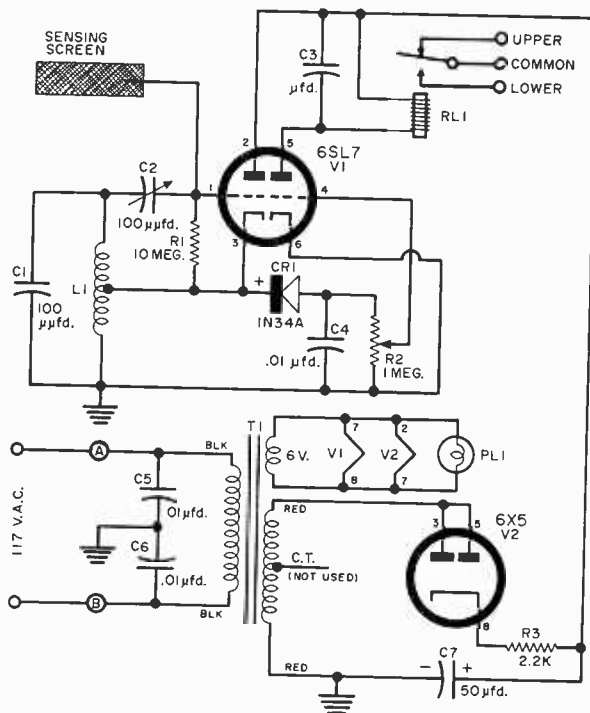



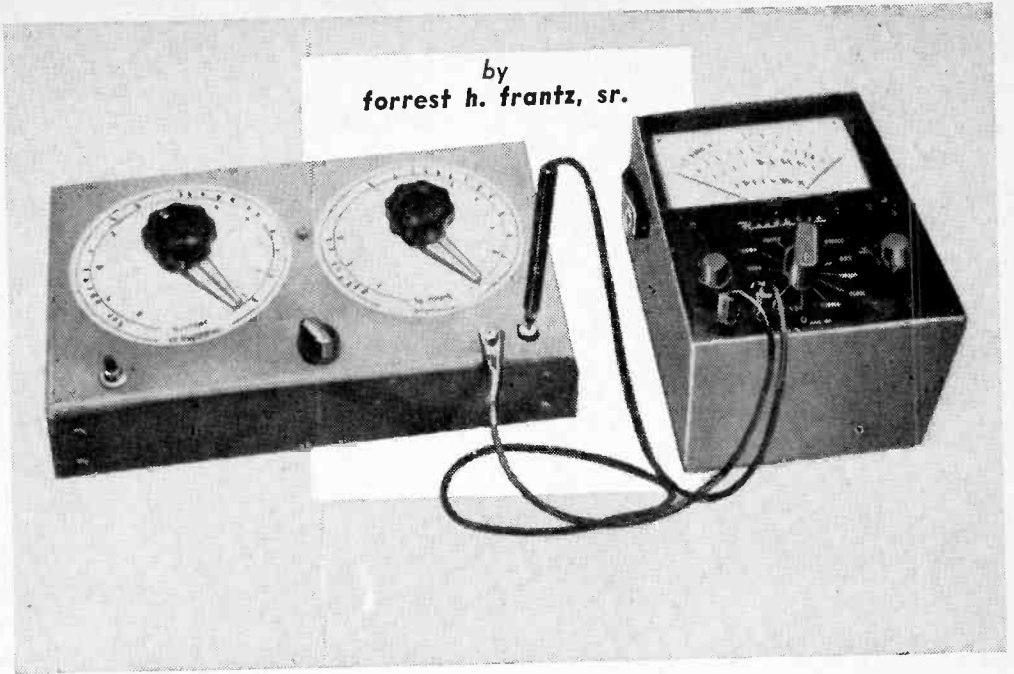

# Compute—With Pots

## MULTIPLY

how to **DIVIDE** and **SUBTRACT**  
**ADD**

with simple potentiometer circuits

When we think about *arithmetic*, we think about addition, subtraction, multiplication and division. *Algebra* extends the usefulness of arithmetic by employing symbols for quantities. *Trigonometry* brings into play the relationship between sides and angles of triangles. Using one or more of these three mathematical approaches, most of the design problems encountered in electronic equipment can be solved. And since these branches of mathematics are required so frequently, long-hand "figuring" is becoming antique and impractical.

New techniques of calculating include the principle of *analogy*. Some physical quantity is used to represent the unit one. For example 1 inch may equal the unit 1 or 1 pound may equal the unit 1. Thus 5 would be represented by 5 inches or 5 pounds. These quantities are then physically added or subtracted, and the remaining quantity is actually measured or weighed to determine the answer. Since mechanical analogies are bulky and sometimes expensive, electrical quantities are more convenient in most cases.

You can multiply a voltage by amplifying it. However, an amplifier usually has constant gain, and in order to create a *variable* multiplier, a gain control (potentiometer) must be included. The potentiometer can then be calibrated in terms of multiplying units.

If a large enough voltage is used and the read-out (indicating) voltmeter is sensitive enough, no amplifier is necessary. A potentiometer calibrated from zero to 10, or zero to 100 can be used to simulate multiplication, although it actually performs division.

**Figure 1.** If an input of 10 volts is applied across the end terminals of a linear potentiometer, 1 volt will exist across terminals 1 and 2 when the shaft is rotated one-tenth

of the way from terminal 1 toward terminal 3. When the shaft is rotated an additional one-tenth (or a total of two-tenths) of the way toward terminal 3, 2 volts can be read. This relationship holds all the way up to the number 10 (at full rotation) where the voltage will be 10 volts.

Thus, a simple pot can be used to generate the numbers from one to ten. If intermediate points are calibrated, numbers like 2.3, or 5.8 are easily generated. If a second pot is connected with its end terminals across the terminals 1 and 2 of the first pot, the second one will "multiply" the number generated by the first.

**Figure 2.** In this simple two-number multiplier, voltage is furnished by a flashlight battery when the momentary contact switch *S1* is pushed. *Rcal* is the calibration control, potentiometers *A* and *B* are operational multiplier elements, and a voltmeter is connected across the output terminals.

Use one flashlight cell if the lowest scale on your voltmeter is 1.5 volts or less; use two cells for 2.5 volts. If the lowest scale is greater than 2.5 volts, but less than 4.5 volts, use six cells in series-parallel to furnish 4.5 volts. (Pots with asterisks in Figs. 2 and 3 are Clarostat Type 58C1.)

The circuit in Fig. 2 will yield most accurate results with VTVM's and voltmeters having sensitivities of 5000 ohms per volt or greater. For voltmeters with sensitivities between 5000 and 10,000 ohms per volt, *Rcal* should be connected as a series rheostat by breaking the connection at the point marked X. A fixed series resistance may have to be inserted in the lead at point Y which can be determined experimentally.

To calibrate: (1) connect your voltmeter to the output jacks and set it to the lowest d.c. volts scale; (2) set *A* and *B* full clockwise beyond 10 on the scale marked *Linear*; (3) push switch *S1* and adjust calibration pot for a full-scale deflection of the voltmeter if you have a scale on your meter that is a multiple of one (i.e., 1, 10, or 100 volts)\*; (4) adjust the dial knobs on potentiometer *A* and *B* shafts so that zero meter deflection is not experienced until the hairlines cross the zero mark; (5) check accuracy by moving pot *A* to the whole number markings from zero to 10 with pot *B* on 10. Record meter readings. Repeat with pot *B* being moved and pot *A* set to 10.

On the dial scale layout for the operational potentiometers, the scale marked *Linear* (which isn't exactly linear since the loading of the following potentiometers is accounted for) is used to represent a number appearing as a multiplier. The scale marked *Reciprocal* is used to represent a number appearing as a divisor.

Suppose you want to multiply 4.7 x 6.9. Perform calibration adjustment (3). Set 4.7 on one pot and 6.9 on the other, and read the result, 32.4, on the voltmeter. Note that the proper scale factor must be used in reading your answer.

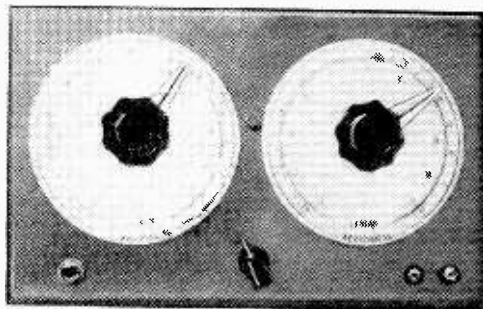
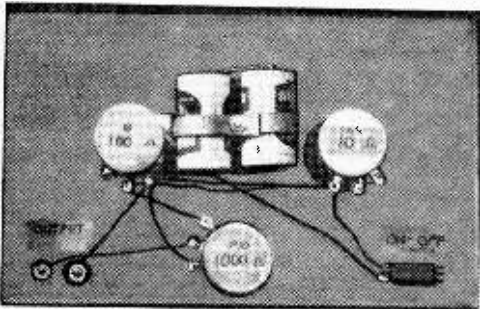

Views of multiplier show the simplicity of the wiring. Use direct, point-to-point connections. One or both terminals should be insulated from the metal chassis.

\* Otherwise, set *Rcal* for deflection to one on the scale which will use the greatest portion of the scale. For example, if your voltmeter has d.c. scales that are multiples of 1.5 and 5, set *Rcal* for deflection to one on the 1.5-volt scale; if your scales are multiples of 2.5 and 10, use the 2.5-volt range, but adjust for full-scale deflection and read results on the 0-10 scale.

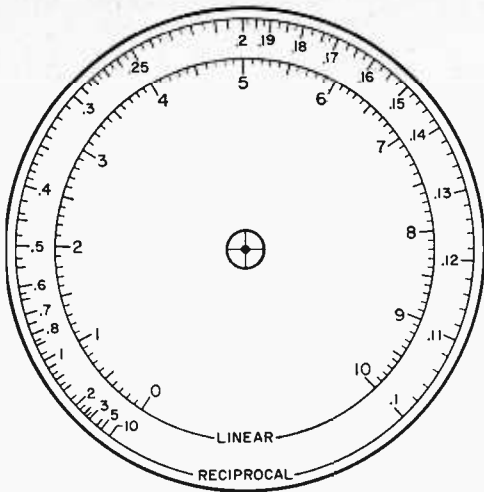

Dial scale layout above is identical for each pot. See text for details.

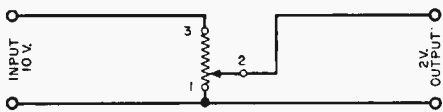

Fig. 1. Basic unit showing mode of operation.

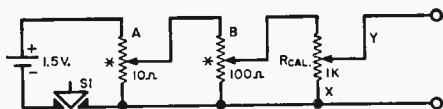

Fig. 2. Two-number d.c.-operated multiplier.

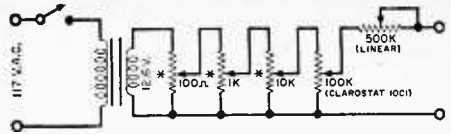

Fig. 3. Four-number a.c.-operated multiplier.

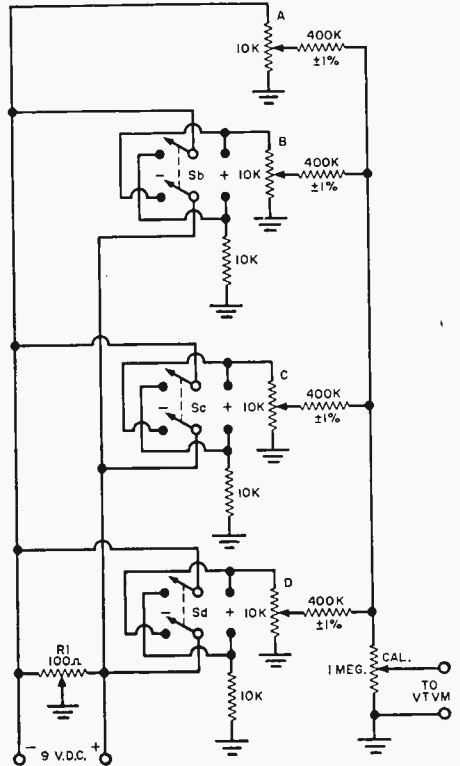

Fig. 4. Four-number adder-subtractor unit.

Thus, to divide 7 by 0.3, set pot *A* to 7 on the linear scale, and set pot *B* to 0.3 on the reciprocal scale. Read the answer, 23, on the voltmeter. This is quite close to the more exact answer, 23.3, and sufficiently accurate for engineering purposes.

**Figure 3.** This advanced four-number multiplier circuit utilizes an a.c. voltage input as an energy source and an audio VTVM for the read-out device. The audio VTVM must be used since output voltage becomes small for most calculations.

**Figure 4.** With this four-number add-subtractor circuit, you can solve problems like  $(1.2 + 4.6 - 7.2 + 9.6)$  in one setup. Balance control *R1* is adjusted for equal positive and negative voltages from ground to potentiometer *R1* end terminals. The "add-subtract" switches *Sb*, *Sc*, and *Sd* allow the polarity of the voltage to the respective pots to be changed so that the numbers represented may be made positive or negative. Currents through the 400,000-ohm resistors are proportional to the potentials at the potentiometer arms. The currents flow through the 1-meg. calibration pot where they are summed.

To calibrate: (1) balance the  $\pm$  balance control (*R1*) with pots *A*, *B*, *C*, and *D* set to 10, switch *Sb* set to (+), and *Sc*, *Sd* set to (-); with the output connected to the VTVM, *R1* is adjusted for zero deflection of the VTVM on the lowest d.c. voltage scale; (2) switch *Sc* and *Sd* to the + position without changing any other control settings, and set the 1-meg. calibration control for a deflection of the VTVM of 4 volts.

by r. i. winklepleck

# check your marksmanship with bullets of light



You will find this light-actuated pistol target range a real test of skill. A 30' range is entirely practical, and the photo-electric "bull's-eye" looks mighty small at that distance. The bull's-eye is one of International Rectifier's new silicon solar cells which imparts a high degree of sensitivity to the unit.

The "gun" design is responsible for making this a true test of your skill. For instead of shooting a solid beam of light with which you could hunt down the target, the gun produces only one brief burst each time the trigger is pulled. You have either a clean hit or a miss—and no weaving of the gun will produce an undeserved score.

Construction is quite simple. Parts layout is entirely non-critical and any arrangement is acceptable. A small sheet of aluminum folded into an "L" shape as shown works nicely, and all components—except the indicating light—can be mounted and wired before the chassis is installed in the target box.

The illustrations show a very satisfactory arrangement. An ordinary door bell can be placed in series with  $L1$  to provide both visual and aural bull's eye signals. Be sure of the polarity of the transistor voltage. One mistake and you'll need a new transistor.

The gun can be built into a rifle or pistol, depending on what's available. Exact arrangement of the few components will be decided by what is used. The 45-volt miniature battery charges a 100- $\mu$ f. capacitor through the microswitch.

When the switch is actuated, the battery circuit is opened and the capacitor discharges through the 6.3-volt #47 type pilot lamp. This produces an intense, brief burst of light which, focused by the simple lens, is sufficient to actuate the target from 30 feet.

The bulb should be mounted vertically with the filament turned parallel to the line of sight. This produces the smallest possible spot of light on the target.

The lens should be a double convex type of 1"-2" focal length and of whatever diameter is needed to fit your gun. A simple "magnifying glass" is ideal. Either the lens or the bulb should be adjustable so that the spot of light can be focused to produce the smallest, brightest spot at shooting distance.

No reflector is required, but you will need to place a black paper diaphragm with a  $\frac{1}{8}$ " hole just in front of the bulb in order to produce a bright, sharply defined spot of light. Possibly you have available an old flashlight "space" pistol of the type illustrated. This is easily modified as shown.

In use, the target should not be placed directly in a bright light nor in darkness. In subdued light, it can be easily seen, sensitivity is excellent and a "miss" is visible on the face of the target.

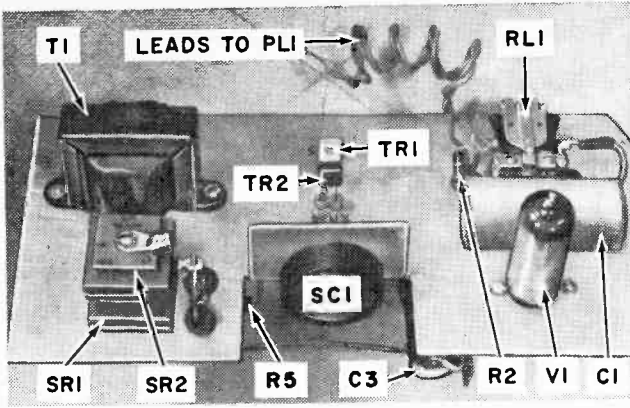

Top and bottom views of the chassis of the photocell unit at left show the uncrowded parts placement. The solar cell (SC1) may have screw mounting terminals or pigtail leads; characteristics of both of these types are similar.

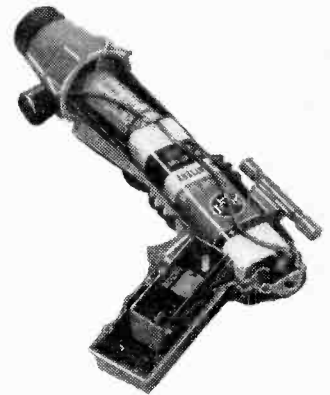
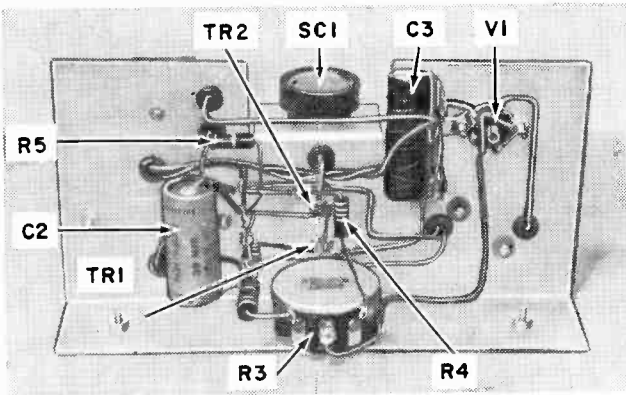

Gun construction is shown above, right. In the schematic directly at right, B1 is an RCA VS 086 battery, C1 an electrolytic capacitor rated at 50 volts, and PL1 is the 6.3-volt #47 pilot lamp. A s.p.d.t. spring return switch serves as gun trigger.

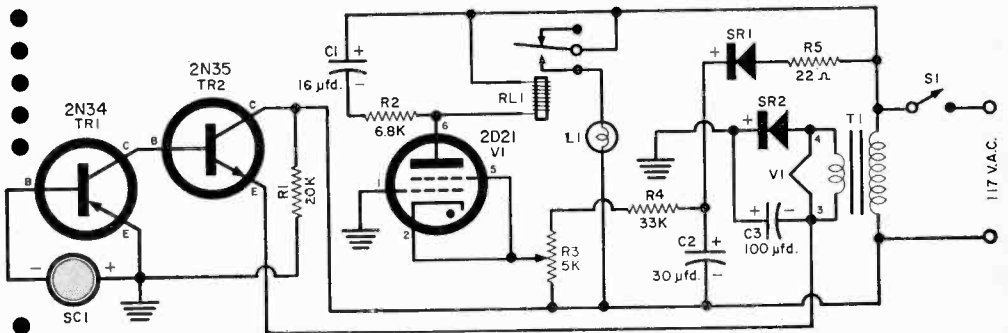
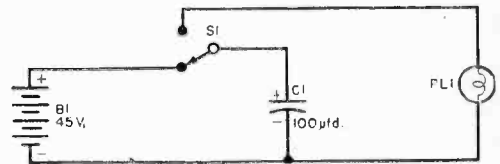

● Pictorial and schematic diagrams of the light target. Several different makes of relays will operate properly. A 1N48 or equivalent diode may be substituted for the selenium rectifier (SR2) which is used as the low-current power supply for the two transistors.

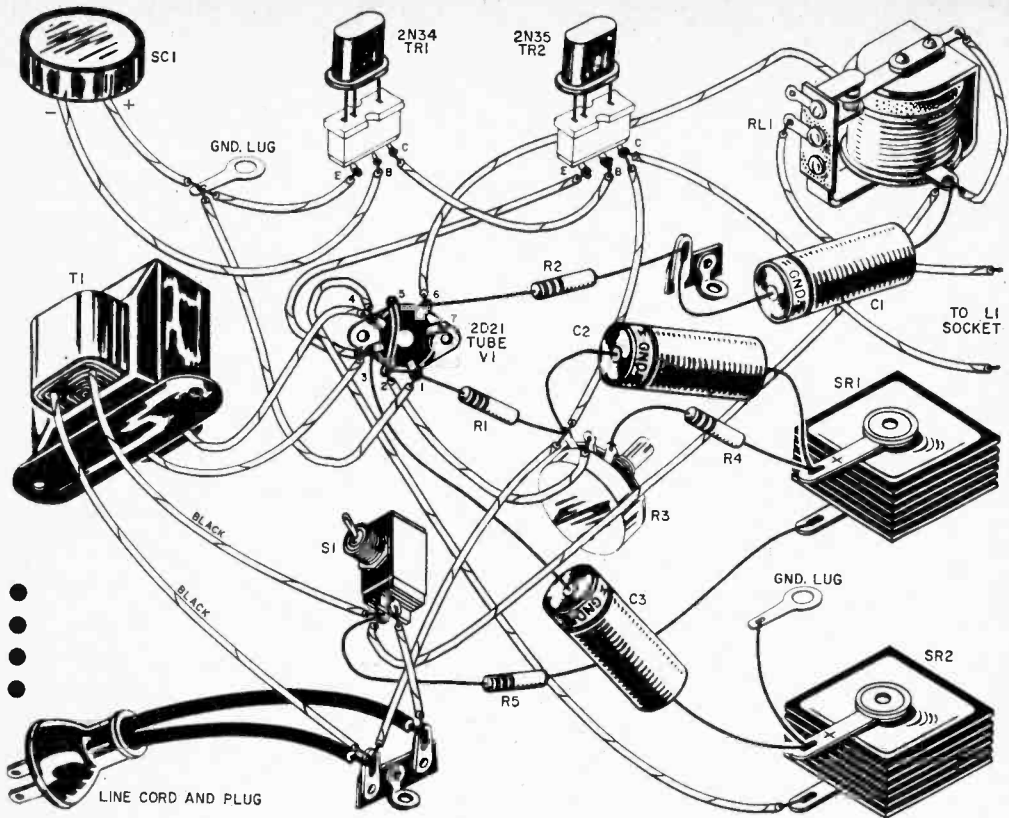

### parts list

- C1—16- $\mu$ fd., 250-volt electrolytic capacitor
- C2—30- $\mu$ fd., 250-volt electrolytic capacitor
- C3—100- $\mu$ fd., 25-volt electrolytic capacitor
- L1—40-watt, 117-volt lamp and socket
- R1—20,000-ohm, 1/2-watt resistor
- R2—6800-ohm, 1-watt resistor
- R3—5000-10,000-ohm wire-wound control
- R4—33,000-ohm, 1-watt resistor
- R5—22-ohm, 1-watt resistor
- RL1—5000-ohm relay (Potter & Brumfield Type RS5D

- or equivalent)
- S1—S.p.s.t. switch
- SC1—Silicon solar cell (International Rectifier SA5-M)
- SR1, SR2—65-ma. selenium rectifier (SR2 may have lower current rating)
- T1—6.3-volt, 0.6-amp. filament transformer
- TR1—2N34 transistor
- TR2—2N35 transistor
- V1—2D21 thyatron tube

### how it works

Light falling on the silicon cell generates a small current which flows into the two-stage, complementary-symmetry d.c. transistor amplifier. The no-light current is minimized by using a p-n-p transistor (TR1) in the input directly coupled to an n-p-n transistor (TR2) in the output stage with the zero-signal collector currents in opposition. Since the n-p-n and p-n-p collectors require voltages of opposite polarity, the power supply is connected in series with the output stage emitter and, through its base-emitter circuit, to the collector of TR1.

This amplifier provides a current gain of approximately 250 and a swing of several volts positive across

its load resistor (R1) which is applied to the control grid of the thyatron "trigger" tube (V1). When this voltage swings positive, the thyatron conducts, the relay in its plate circuit closes, and a light flashes or a bell rings—indicating a bulls-eye.

Potentiometer R3 applies bias to compensate for incident light and functions as a "sensitivity control." Alternating current is supplied to the plate of the thyatron (V1) so that conduction ceases when its grid drops below the firing potential. Voltage for the transistor amplifier is taken from the filament transformer (T1), rectified and filtered.

### graphic vacuum-tube mount

Graphic terminal boards make it a pleasure to experiment with various vacuum tubes and circuits. Fahnestock clips allow quick connections; the picture shows just where the

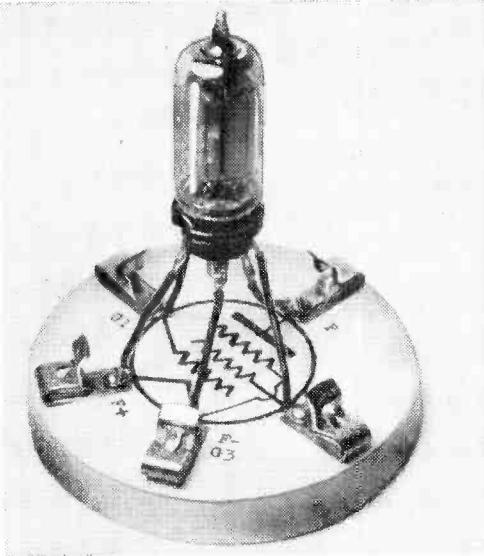

connections go. Radio students and experimenters can make up a number of these graphic tube mounts, one for each of the most commonly used tubes, and save much time and trouble when trying various hook-ups. —A. T.

### protecting phone plugs

To protect phone cords—and other connecting cords—from wear due to friction and bending at the place where they enter the plugs, it's a good idea to cover the cords with sleeves made from soft rubber or soft plastic tubing. Of course, if the cord you want to cover uses phone tips, be sure the tubing is large enough to pass the tips. If necessary,

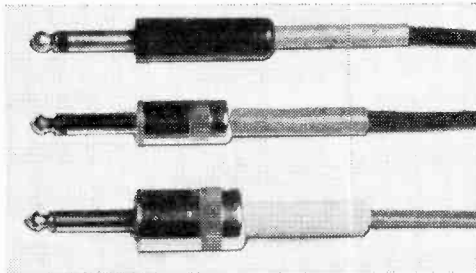

the opening in the back end of the plug can be enlarged a little to pass the tubing. The tubing can be anchored to the cord inside the plug by wrapping it with tape. —A. T.

## RADIO CONTROL HEADQUARTERS

For model airplanes, boats, cars, etc. FREE CATALOG X No operator's license required. FREE—send for FCC Form 505

**HANDIE TALKIE** Basic Transmitter & Receiver Chassis. New. Wired. with Dual Tube. **\$7.65**

**BEFORE YOU BUY COMPARE: (27.255 Mc.) Most Powerful R/C TRANSMITTER Hand Held Model A-1—Made in USA**

• Greatest Power—up to 5 watts input  
• Greatest Distance—Range up to 3 sq. miles  
• Gyro Magic Tuning Indicator—simplest tuning  
• Versatile—operates from 90 to 180 Volts "B"  
• Complete & Guaranteed with Antenna  
Ready to operate (less battery) **\$17.95 Complete Kit \$11.95**

**R/C RECEIVER** 27 1/4 Mc. Complete **\$8.61**  
with Relay, Tube & Accessories.  
Factory Tested. Small, approx. 3 Oz.

"MITE" MINI RELAY 5000 ohm, 1 1/4 Ma Pull-in. **2.50**  
New! COMPOUND ESCAPEMENT **\$3.95**; SN ESCAPEMENT **2.95**  
STORAGE BATTERIES: 8B54, 2V, 3"x1"x3 1/4", 27 Amp/Hr **4.25**  
N76 MINI 6 Volt, 3 Amp/Hr, 2 1/4"x1 3/8"x3 1/4" **3.45**  
R/C TRANSMITTER & RECEIVER KIT: 27 1/4 Mc. 5 watt 2-Tube Simple Transm. & 2-Tube Rec. incl. Drilled Bases, Wound Coil, Res., Cond., SIGMA Relay, Instructions. **\$9.95**  
SIGMA 4F RELAY: 8000 ohms **\$5.95**; 6-REED-RELAY **14.95**  
F. C. BOOKS: Model Control **\$1**; Radio Control **\$1**; Handbook **2.25**  
CRYSTALS: 27.255 Mc. **\$2.65**; HOLDER. **1.15**  
2" METERS: 0-1 Ma. **\$3.65**; 500 MicroA **\$3.95**; 3 Ma. **2.95**

Pocket MULTITESTER: 3000 ohm/volt, checks volts, ohms, ma., 11 ranges, uses 1 1/2 multipliers. **\$9.95**

2-6V BATTERY CHARGER KIT **\$4.95**; WIRED **6.95**  
CHARGER for DRY BATTERIES will charge standard dry cells (1.5-90V) up to 5 times original life. **4.95**

RELAY CONTROL UNIT incl. Sensitive 10,000 ohm Sigma Relay (1 1/2 Ma.) Thermal Bi-metal Strip, Heating Element, Hi Z Audio Choke, Mini Alnico Magnet, Neon Lamp, Resistors, Capacitors. **ONLY 99c**

MINI STORAGE CELLS 2V 75c. ELECTRIC MOTOR 1 1/2V .95  
TUBES: 6X4, 6X4, 6X4, 6X4, 6X4, TRANSISTOR .99  
RELAYS: 10K ohm 2 Ma DC or 110V AC SPDT 95c; SPST .85

EXPERIMENTERS' SPECIAL! 10 lbs. Electronic Parts, incl: Coils, Transformer, Choke, Capacitor, Resistors, Neon, Disc Magnet, Bimetallic switch, Wire, Spaghetti. **1.95**

Experimenters' SOLDERING IRON **.99**  
EARPHONES: Plug-In Type **\$1.95**; Standard, Dual 2000 ohm **2.50**

Experimental 2V DC MOTOR & GEARS **1.25**  
THROAT MICROPHONES 95c. TOY MOTOR KIT **.45**

DYNAMOTORS: 6V-150V @ 100 Ma. **6.95**  
12/24V in. 250/300V @ 50 Ma. **9.95**

Mini TRANSMITTER—Radiosonde 390-410 Mc. with 2 Tubes in small box 2 1/4"x2 1/4"x1 1/4" **1.50**

Radiosonde MODULATOR Assembly incl. Mini Sens. Relay, Aneroid Barometer operated Slide Element, in plastic case **1.50**  
Coiled PHONE CORD: 3-Conductor, stretches to 6 ft. **.95**  
MICROSWITCH Mini 1SM1 **\$1.25** Regular Size **.65**

**GYRO ELECTRONICS CO.** 36 WALKER STREET, X, NEW YORK 13, N. Y.

# FREE

## GIANT NEW CATALOG

### 1959 B-A

A COMPLETE BUYING GUIDE FOR EVERYTHING IN

## RADIO TV ELECTRONICS

# BA 1959

ANNUAL CATALOG '59

SINCE 1927

**BURSTEIN-APPLEBEE CO.**

Dept. XH, 1012 McGee St., Kansas City 6, Mo.

Send Free 1959 B-A Catalog No. 591.

Name: \_\_\_\_\_

Address: \_\_\_\_\_

City: \_\_\_\_\_ State: \_\_\_\_\_

**180 KING-SIZED PAGES**

EVERYTHING IN RADIO TV AND ELECTRONICS

100'S OF NEW ITEMS LISTED HERE FOR 1st TIME

21 PAGES OF BARGAINS NOT IN ANY OTHER CATALOG

SEND FOR IT TODAY

# Play Games

## with Nixie Tubes



by harvey pollack



Nixie Gamester installed in its grey aluminum cabinet. Activating button is in the center of the front panel.

### "NIXIE" GAMES YOU CAN PLAY

**Bingo.** This game is played in the usual manner. The players are issued numbered cards on which the numbers are crossed out as the Nixie Gamester reads them out. When all the numbers in any horizontal, vertical, or diagonal row are crossed out, the player calls out "Bingo" and is a winner. Unlike other readout methods, the Nixie numerals are clearly visible to all players.

**Roulette.** A good system to use for this game is the addition of numerals. For instance, if the Nixies show a 3 and a 6, then the winning number is 9. For double zero (00) or a double blankout, all points go to the bank. A large piece of oaktag divided into 18 squares makes a good roulette board.

**Monopoly, Cops-and-Robbers, etc.** Any game played with dice or a spinning pointer is a natural for the Nixie Gamester. Make up your own house rules as to whether the digits are added or subtracted.

**Party Games.** The Nixie Gamester provides a new twist on the ancient games of "Spin the Bottle" and "Post Office." If there are ten couples at the party, each girl and boy are assigned a number (left-hand Nixie for the girls, right for the boys). A tantalizing spin of the motors, and a girl and boy are paired at random to go out and look at the stars. Should there be fewer than ten couples, certain lucky ones may be assigned two numbers, thus doubling their opportunities to have a chance at some social astronomy. In this game, a single or double blankout has no significance.

**Quizzo.** The group is divided into two teams. As the Nixie Gamester calls out the digits, the "left" team and "right" team must answer questions numbered according to the readout. Other variations of this idea are easy to dream up so that the party can be kept under full steam.



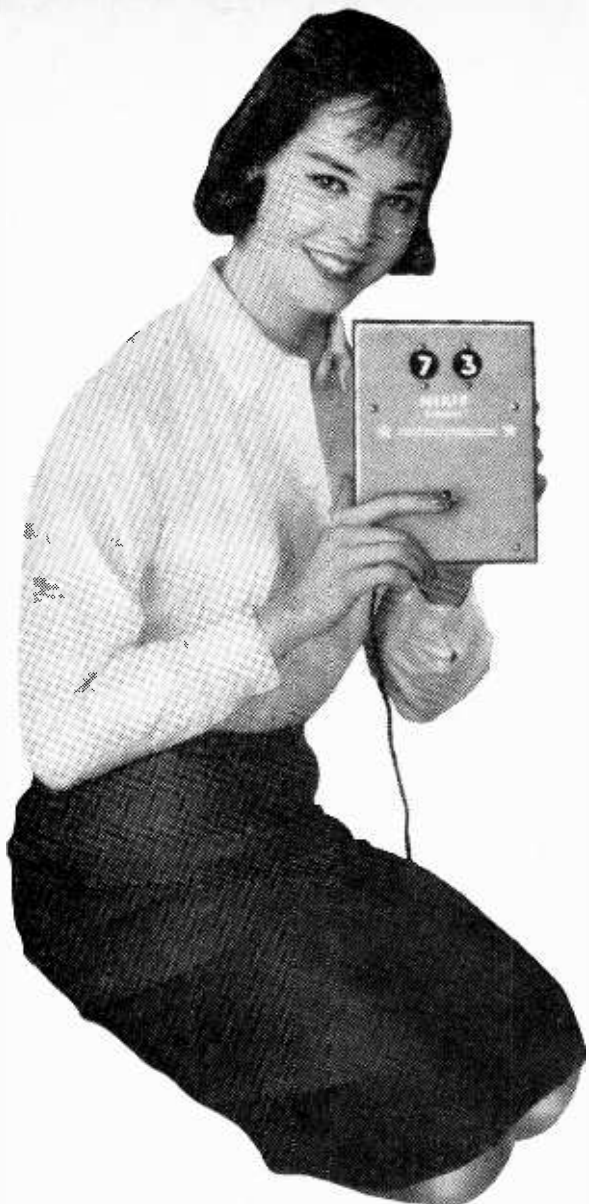

You can throw away the whirling number wheels, the tumbling golf balls in the squirrel cage, and the gallopin' dominoes! It's much more fun to play Bingo, Roulette, Put-and-Take, Quizzo, boy-girl parlor games, and a host of other games — electronically! By merely pressing a button, you can display a pair of randomly selected numbers for all kinds of numerical games in shining neon lights visible up to 20 feet away.

This simple form of digital presentation is made possible by a modern little electron tube called a "Nixie." Although specifically designed for computer panel read-out systems, the Nixie can be used in any device where any digit from 0 to 9 is to be displayed to a group of viewers.

By using two Nixies, a pair of tiny electric motors, two printed-circuit commutator boards, and a suitable power source, you can make up a game machine that will put new life in the dulllest party, spark community and church affairs, and even help the youngsters in the house practice their arithmetic. All you do is push the button. Whirling motors flash the Nixie numbers inside the tubes too fast for the eye to follow. When the button is released, the motors come to rest, leaving two glowing numbers for everyone to see.

Numerical selection is accomplished by a wiper installed on the motor gear. As the armature rotates, the wiper arm contacts successively ten copper segments separated by etched grooves on a printed-circuit board which serves as a commutator.

### prepare the commutators

Using a fine-toothed hacksaw blade, cut a single piece of 2" x 4½" XXXP copper laminate board exactly in half. Make up a little cardboard wedge having an angle of exactly 36° with the help of a protractor. Using the wedge as a template, divide the laminate into ten equal segments of 36° each, and score the copper lightly with a sharp-pointed tool to mark the divisions.

Lay strips of ½" resist tape over the score lines and press their adhesive sides firmly down on the copper. Carefully paint the liquid resist over the entire board, leaving about ½" of copper exposed along the bottom as shown in photo above. Repeat this procedure

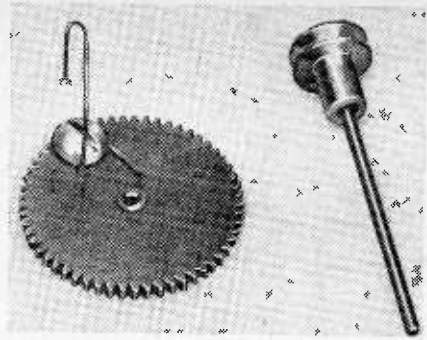
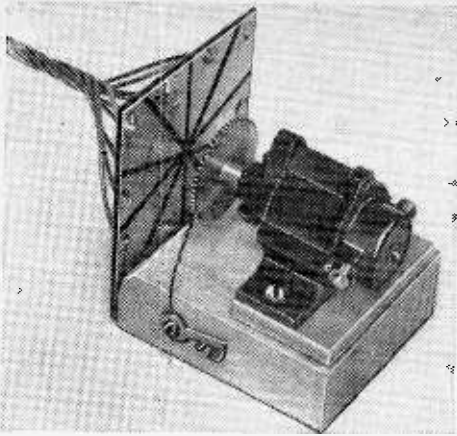

Completed motor and wiper assembly is shown at left. Large gear above with wiper wire in place. Small pulley and shaft are not used.

with the second copper plate and set both pieces aside to dry for about a half hour.

After this interval, remove the resist tape and immerse the plates in the etchant bath, leaving them in long enough to remove all the copper in the clear grooves between segments and the strip along the bottom. When the etching is complete, rinse the boards in clear running water and then brush a little paint remover over them. You'll find that the liquid resist is softened enough in a minute or two so that it can be wiped off with a cloth.

Finally, wash the plates in soap and water and dry them thoroughly. Drill a very fine hole in each segment as close to the outer edge of the wedge as you can work. Tinned hookup wire will be passed through each of the holes for wiring to the Nixie sockets as described later.

### motor mounting

Loosen the setscrew on the large gear and slip it off its shaft. This will free the pulley and pulley shaft, which should then be removed altogether. While you have the large gear handy, drill and tap a hole to take a 4-36 brass screw about  $\frac{1}{4}$ " away from the toothed circumference. The wiper arm is made of thin wire (about #28) folded into a hairpin shape at the end and looped under the screw head. Spring wire is best for this, and phosphor-bronze or steel will do fine. The model illustrated has Nichrome, which happened to be available.

Mount the motor on the two pieces of wood which serve as base blocks. Note that the motor is screwed to a small piece of plywood which raises it enough to permit the

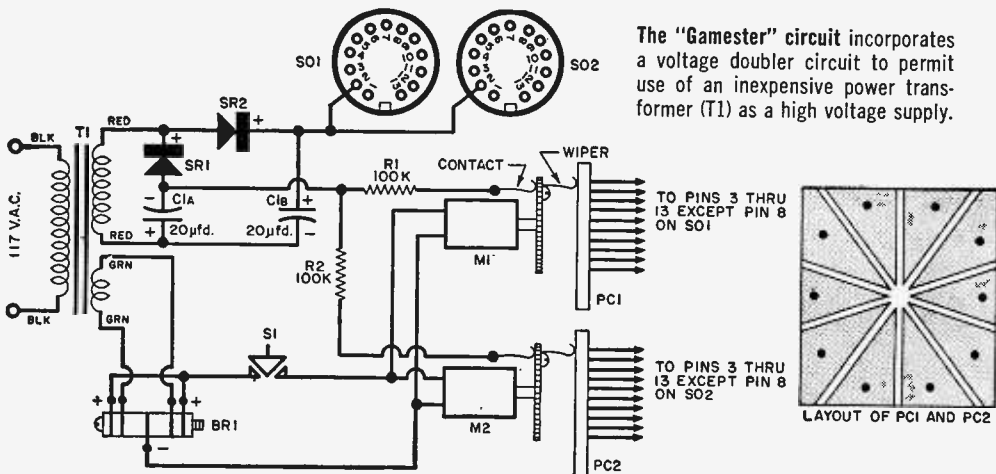

gear to spin clear of the larger block. Using short wood screws, fasten the commutator board to the side of the base block so that the clear center of the segments is directly opposite the motor shaft. Thus, as the wiper spins, it will rotate in a circle having the center of the commutator as its center of rotation.

Another piece of the same spring wire serves as the contactor which rides on the back of the gear as the motor turns. It is held in place by another wood screw as shown and its pressure is adjusted so that it doesn't slow down the motor. It's a good idea, too, to connect the 100,000-ohm resistor at this time, holding it in place with a solder lug at each end. *The resistors act as protective devices for the Nixies and must not be omitted.*

The Nixie Gamester is a.c.-operated. One low-cost transformer supplies the anode power for the numerals and the low voltage for the motors. A full-wave voltage doubler consisting of *SR1*, *SR2*, and the dual capacitor *C1a/C1b* comprise the anode power supply, while an inexpensive magnesium-copper sulfide bridge rectifier without filtering takes care of the motor drive.

All parts, except the push button and the Nixie sockets, are mounted on a sheet of perforated Bakelite. Wiring is completed outside the case and the finished assembly secured to the case by a long machine screw and brass spacer in each corner.

### wiring the sockets

After you punch two 1" holes where the Nixies are to go, fasten the little glow tubes and their sockets in place with a 1¼" machine screw through each socket-flange hole. (The diameter of the Nixie is 1.080" so it cannot slip through the hole). In this way, only the face of each tube will be visible through the hole and the display will be much more effective.

Be sure to mount the sockets with pins 1 and 8 in a vertical line, pin 8 nearest the top of the panel. Pass a very short length (about ¼") of the stripped end of hookup wire through each of the small holes in the commutator segments and solder to the copper faces carefully. Don't use too much heat. Trim the ends of the wire off after the solder has cooled.

The actual wiring should be done in a random fashion. Don't connect segment 1 to the socket lug for display number 1, segment 2 for number 2, etc. The numbers should follow each other haphazardly so that it will be impossible to force the motors to stop at any given place. Note that no connection is made to either pin 1 or pin 8 on the socket and that the common anode connection is pin 2.

To be sure that your Gamester will play a fair game, run through the following tests:

(1) *Wiper contact*. With power on, slowly rotate each gear by hand and observe the corresponding Nixie. Only one number should glow for each contact of the wiper on a given segment of the copper. If one or more numbers do not appear, bend the wiper so that it makes firmer contact. If more than one number is displayed for any single contact, it means that there is a bridge of copper between segments that was not etched away. A bridge like this can be picked off with a sharp point and the insulating groove cleared.

(2) *Contactor*. While each gear is manually rotated, observe the rear contactor to be certain that it maintains electrical touch with the rear face of the gear throughout the entire rotation.

(3) *Motor spin*. Motors should start instantly when the power is applied and should spin at high speed. If they don't do this, reduce wiper and contactor pressure by bending the wires back very slightly.

(4) *Blankouts*. The small contact surface of the wiper permits it to come to rest occasionally between segments. When this happens, the corresponding Nixie will not glow. Chances of both wipers blanking out on the same spin are very remote. You should, however, run through a number of spins watching for this kind of thing. If it happens too often, the wiper is catching on the edge of one of the segments as a result of excessive wiper pressure. A single blankout provides a one-digit readout and is desirable for most games in which the numerical sequence wanted runs from zero to 99.

# authoritative, entertaining, informative...

SEND FOR THESE ZIFF-DAVIS  
SPECIAL-INTEREST PUBLICATIONS TODAY

Here are six exciting popular-priced Annuals published by Ziff-Davis that you can order by mail. Take one or take all—you'll find these publications will help you in your career or hobby... save you money on hi-fi, photography, electronic do-it-yourself projects—offer you fun and enjoyment. Use the convenient order form below to make your selections today.

## YOUR CAREER IN ELECTRONICS, 1959 edition

This Annual can start you on a profitable career in electronics! Tells you how to get started, what an electronics company expects of you, gives personal experiences of men actually working in the field. Helpful section on deciding your future; complete with a career planning chart, aptitude tests, reports on schools and colleges, how on-the-job training works. Plus valuable tips on earning money in electronics in your spare time. 200 illustrations, 128 pages, \$1.00



## 1959 HI-FI DIRECTORY & BUYERS' GUIDE

It's smart to know your hi-fi equipment before you buy! And it's easy with the 1959 HI-FI DIRECTORY—the world's most complete reference to prices and specifications on virtually every piece of hi-fi equipment on the market. Tells you what to look for, how to buy, how to spot a bargain. Sections on tuners, amplifiers and preamps, record players, changers, turntables, tone arms, cartridges, cabinets and enclosures. 180 pages, \$1.00

## ELECTRONICS KITS, 1959 edition

Shows you how to save on hi-fi equipment, ham radio, and other electronic devices by using easy-to-assemble kits! Tells what tools you should have, how to put together your own hi-fi set, electronics laboratory, short-wave receiver, electronics accessories for your car and boat, photoelectric eyes, pocket radios—30 construction articles and 640 illustrations. Plus the world's only complete directory of electronics kits, including specifications and prices. 160 pages, only \$1.00



## 1959 PHOTOGRAPHY ANNUAL

The Editors of Popular Photography selected over 300 great pictures to go into this year's 242-page edition. Features the best shots of the year—sports, glamour, action, portraits, landscapes, children—in color and b&w. Covers all phases of photography: photojournalism, industrial, fashion, advertising, portraiture. Plus Eugene Smith's famed picture poem to Pittsburgh, an International Portfolio and a reference section describing how each picture was taken. Only \$1.25

## 1959 HI-FI ANNUAL and AUDIO HANDBOOK

All the skill and know-how of the nation's top hi-fi authorities are yours in this inexpensive book that will add countless hours to your high fidelity pleasure! Its 43 articles and 325 illustrations cover every phase of hi-fi enjoyment—how to convert to get started in stereo and FM, amplifiers and preamps, tape recorders, microphones, loudspeakers and enclosures. Plus 20 pages by G. A. Briggs of Wharfedale on "All About Audio and Hi-Fi". Prepared by the Editors of Radio & TV News, \$1.00



## 1959 HOME MOVIE MAKING ANNUAL

For the first time you can get an inexpensive A-to-Z course in home movie making! 150 pages of expert advice by the Editors of Popular Photography and well-known Hollywood professionals on shooting quality home movies. You'll get 100 ideas for home movies, directions for making an old time comedy, a primer on color, when and how to pan, how to splice, edit, add sound. Extra: a giant equipment facts section that is a complete directory of amateur motion picture equipment. Only \$1.00

### ORDER THESE ANNUALS BY MAIL NOW:

Check Annuals desired:

- YOUR CAREER IN ELECTRONICS, \$1.00
- ELECTRONICS KITS, \$1.00
- 1959 HI-FI ANNUAL, \$1.00
- 1959 HI-FI DIRECTORY, \$1.00
- 1959 PHOTOGRAPHY ANNUAL, \$1.25
- 1959 HOME MOVIE MAKING ANNUAL, \$1.00

ZIFF-DAVIS PUBLISHING COMPANY EEH-9  
434 South Wabash Avenue, Chicago 5, Illinois

Please send me the Annuals checked. My payment is enclosed plus 10c for each Annual to cover postage and handling.

NAME \_\_\_\_\_

ADDRESS \_\_\_\_\_

CITY \_\_\_\_\_

STATE \_\_\_\_\_



## section **VI**

### for your work shop

- |  |            |
|--|------------|
| pocket test instruments — voltmeters             | <b>132</b> |
| pocket test instruments —<br>audio generator     | <b>137</b> |
| pocket test instruments — r-c checker            | <b>141</b> |
| build a square wave generator<br>for audio tests | <b>146</b> |

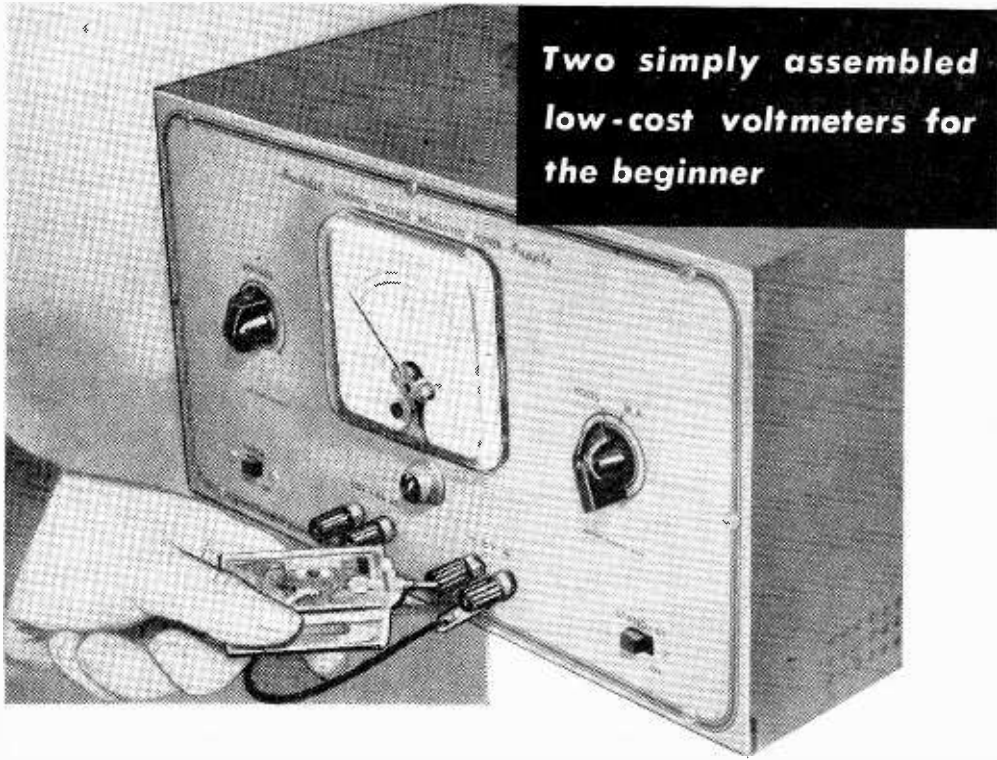

# Pocket Size Test Instruments

## Part 1

by e. g. louis

Whether you're a part-time or full-time serviceman, a student-experimenter, an R/C enthusiast, a ham, an audio fan, or a home builder of electronics gear, chances are that you've often wished for a set of pocket-sized test instruments. The serviceman can use miniaturized equipment for quick checks of receivers and amplifiers in a customer's home; the ham can use such instruments for testing his mobile rig or for checking out his portable equipment on periodic field days; the home experimenter will find that pocket-sized instruments require less of his limited—and valuable—bench space, leaving more room for construction projects and circuit assemblies.

If you're willing to invest a few dollars and two or three hours of your time, you can assemble your own set of "tom-thumb" instruments. With a well-stocked junk box, you may be able to reduce out-of-pocket cost to small change. All you'll need is a handful of resistors and capacitors, a few controls and switches, and an assortment of small metal or plastic boxes, plus the usual "hardware" found around the lab or workshop. For an

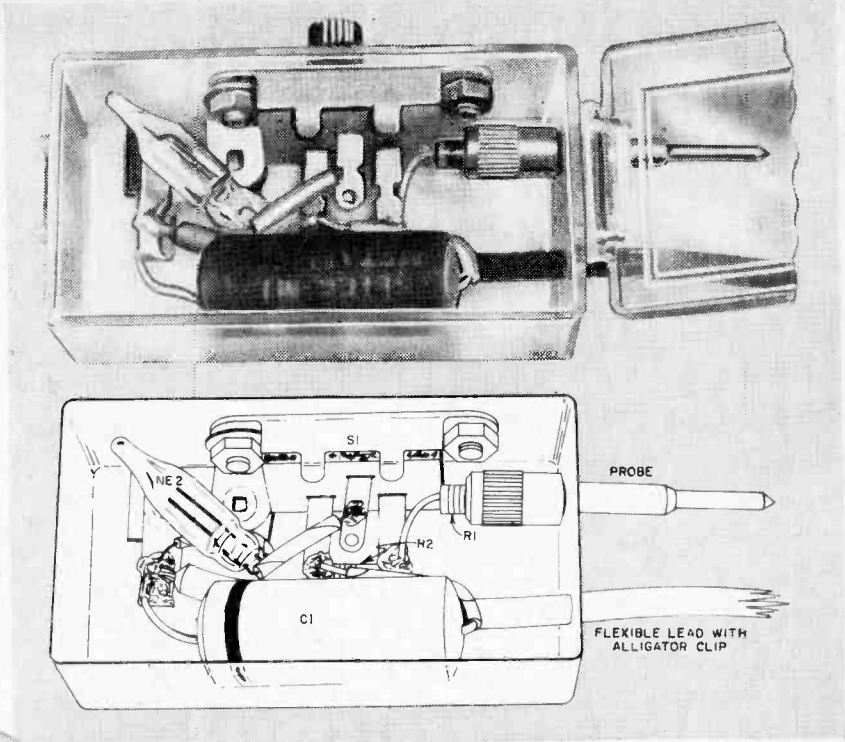

Probe tip in pulse rate meter at right may be secured in place with Duco cement or glue.

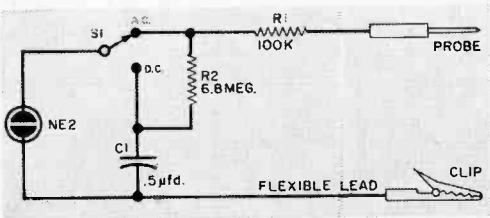
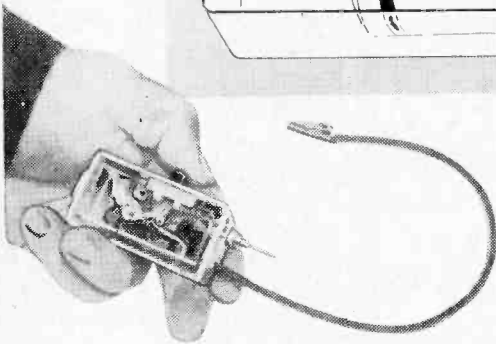

Pulse rate meter operation is based on a special neon lamp characteristic. Calibration may be upset by exposure to intense light during measurement because of the lamp's particular sensitivity to changes in breakdown point under strong illumination.

**parts list**

- C1—0.5- $\mu$ fd., 400-volt metalized paper capacitor
- R1—100,000-ohm, 1/2-watt resistor
- R2—6.8-megohm, 1/2-watt resistor
- S1—S.p.d.t. slide switch
- 1—NE2 neon bulb
- Misc. small plastic case, terminal strip, alligator clip, wire, solder, machine screws and nuts, etc.

indicating device you can use a low-cost neon bulb instead of a relatively expensive meter.

The voltmeter is one of the basic instruments needed in electronics servicing or in laboratory work. So you'll probably want to start with one of these. Described below are *two* types of pocket-sized neon-bulb-operated voltmeters that you can assemble. In later articles, we'll discuss the construction of other instruments, including an audio generator and a unique R/C tester.

**pulse rate voltmeter**

Often, when making a quick check of amplifiers and radio receivers, our immediate interest is to see if B+ and plate voltages are available, and what their *approximate* value is, rather than *exactly* how much voltage is available. We may need to know whether we have, say, *about* 300 or *about* 100 volts rather than exactly 285 or 300 volts. The pulse rate voltmeter is designed to simplify this type of measurement. Even though the instrument has no meter to read nor dials to adjust, it is still possible to obtain a fairly good approximation of d.c. voltages with it.

Using only two resistors, one capacitor, a

slide switch and a neon bulb, the pulse rate voltmeter is inexpensive and easy to build. Just follow the wiring diagram and illustrations. Don't worry about layout and circuit lead dress—they aren't critical. But make sure that the switch is easy to manipulate when the instrument is held in one hand, and that the neon bulb is clearly visible.

With normal B voltages such as are found in radio and TV receivers (90 to 450 volts), the pulse rate is slow enough to follow with the eye. By mentally counting the number of pulses per second, the operator can make a close estimate of the voltage applied to the instrument. The higher the voltage, the more rapidly *C1* can charge to the firing voltage of the neon bulb, and hence the higher the blinking rate.

When connected to a source of a.c. voltage, the capacitor acts as a "short" across the neon bulb and the bulb does not light. The switch (*S1*) is turned to the "AC" position, changing the instrument into a simple neon-type indicator, with *R1* serving as a current-limiting resistor. With this arrangement, the bulb lights whenever the applied voltage "peaks" above the nominal firing voltage of the bulb—say from 70 volts (r.m.s. a.c.) up.

Although it is difficult to estimate a.c. voltage values—except by the relative brightness

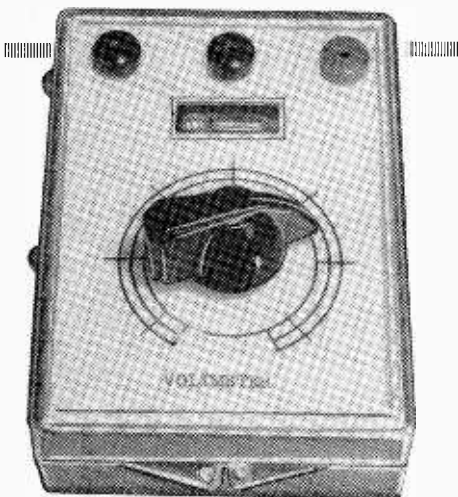

Neat panel layout and compactness characterize the volt-output meter. Its plastic case eliminates possibility of shock during measurement. At right, the meter is shown in operation. Rubber-shielded alligator clips are recommended for all connections to receivers when they must be worked on "live."

### how it works

This is a basic relaxation oscillator for d.c. measurements and a simple indicator for a.c. voltage tests.

With *S1* in the "DC" position, and the instrument connected to a d.c. voltage source, capacitor *C1* is charged slowly through series resistors *R1* and *R2*. When the charge across *C1* reaches the "firing voltage" of the neon bulb, the bulb "fires," discharging the capacitor.

The capacitor then recharges slowly until the firing voltage is reached again, and the action continues. The neon bulb "blinks" or lights each time it fires; this blinking rate is dependent on the RC time constant and on the voltage applied to the circuit. Since the RC time constant is fixed by the values of *R1*, *R2* and *C1*, the blinking or pulsing rate depends only on the d.c. voltage applied to the instrument.

of the neon bulb—this is no drawback to the instrument's application. In most cases, when used as an a.c. voltmeter, the unit is primarily employed to indicate the *presence* of, say, a.c. line voltage.

To "calibrate" the voltmeter, simply connect the unit to measure known d.c. voltages and note the approximate number of pulses (blinks) obtained per second. Different d.c. voltages can be obtained from an adjustable d.c. power supply, or from the B supply circuits of radio and TV receivers. If you don't know the voltages that are available in a particular test, you can use a standard voltmeter while you calibrate the instrument.

The pulse rate voltmeter is not "polarized," i.e., *either* lead may be connected to

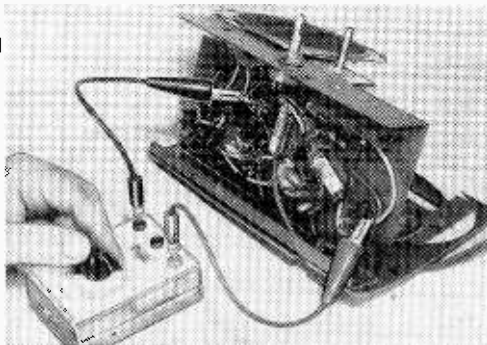

the positive terminal (with the other lead connected to the negative side of the voltage source). To check the polarity of an unknown voltage, just note *which* of the neon bulb's two electrodes lights with a given arrangement of the test leads during the initial "calibration tests." Remember which electrode lights when, say, the "ground lead" is connected to B—, and you won't have any trouble identifying unknown voltages.



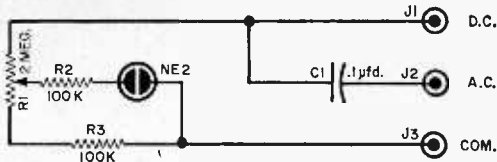
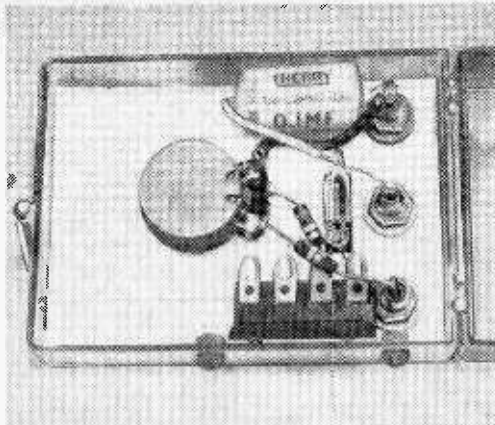

### parts list

- C1—0.1- $\mu$ fd., 600-volt metalized paper capacitor
- J1, J2, J3—Phone tip jack
- R1—2-megohm potentiometer (linear taper)
- R2, R3—100,000-ohm, 1/2-watt resistor
- 1—NE2 neon bulb
- Misc. small plastic case, knob, terminal strip, wire, solder, machine screws and nuts, etc.

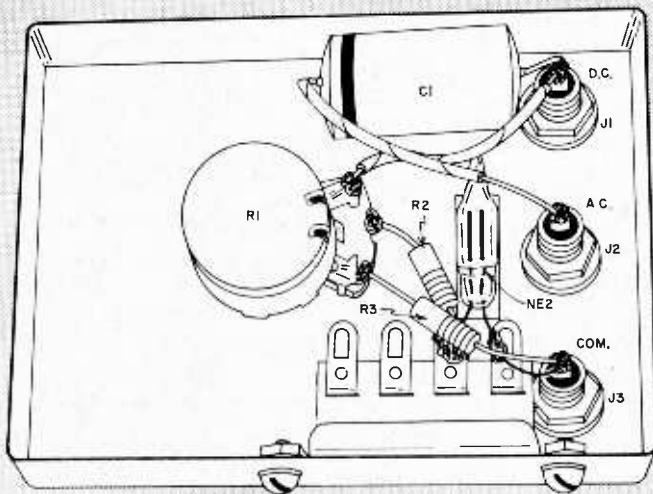

Internal view of the volt-output meter shows the extreme simplicity of layout and construction. Component cost is exceptionally low.

### how it works

In operation, potentiometer R1 and fixed resistor R3 form a simple adjustable voltage divider, while series resistor R2 serves to limit the current through the neon bulb to a safe value.

With a d.c. voltage applied to the "COM." (J3) and "DC" (J1) input terminals, and the center arm of R1 turned all the way "down," the only voltage applied to the neon bulb (through R2) is the voltage appearing across R3. This is relatively small compared to the applied voltage due to the relative sizes of R1 and R3.

As the center arm of R1 is advanced "up," the voltage applied to the neon bulb increases until its "firing voltage" (about 60 to 70 volts) is reached, at which time the bulb lights. The point of R1 rotation at which the bulb lights depends on the voltage applied between the "DC" and "COM." terminals; hence, a dial indicating the rotation of R1 can be calibrated directly in applied voltage.

An a.c. voltage can be measured in much the same manner, except that the bulb lights on the "peak" of the applied voltage rather than on its r.m.s. value. Thus, separate calibration scales are required for a.c. and d.c. measurements. Where d.c. and a.c. voltages are available at the same point (pulsating d.c.), as on the plate of an audio output tube, and it is necessary to measure only the a.c. components of the voltage, a blocking capacitor is connected in series with one of the leads. In our combination instrument, the blocking capacitor (C1) is built-in, and is connected to a separate "AC" terminal (J2).

When you want to check a.c. line voltages, flip the switch (S1) to the "AC" position. On these measurements, the neon bulb will glow steadily (will not blink), and *both* electrodes will light.

### combination volt-output meter

While the compact and easy-to-use pulse rate voltmeter is quite satisfactory for quick preliminary tests, you may want to make more accurate voltage measurements, or you may sometimes want to measure the a.c. component of a pulsating d.c. signal. This last measurement is generally made with an *output* meter.

You needn't go to an expensive instrument for such tests. By wiring a potentiometer-type neon voltmeter in a plastic box about the size of a package of cigarettes, adding an indicator dial and a d.c. blocking capacitor, you



# NEW SCI DIRECTORY

goes on sale soon

Imagine having access to the largest, most complete sports car showroom in the world—where sports and economy cars of every make and model are waiting for your inspection. A unique showroom—with no fancy talk, but plenty of good, solid facts. A place where you can browse for hours on end and check out just about every car available—

That, in effect, is what the SPORTS CARS ILLUSTRATED DIRECTORY represents. It's the world's most complete guide to the buying and servicing of sports and economy cars. On sale soon at newsstands all over the country, the 1959 edition of the SPORTS CARS ILLUSTRATED DIRECTORY has 160 pages of valuable, helpful information like:

**ROAD TESTS OF THE EIGHT MOST POPULAR SPORTS CARS** — Alfa Romeo, Austin-Healey, Corvette, Jaguar XK 150 S, Mercedes-Benz 190 SL, MGA Coupe, Porsche Coupe, and the Triumph TR3 A.

**BUYER'S GUIDE TO READILY AVAILABLE SPORTS CARS** (complete with spec sheets)—A.C., Arnolt-Bristol, Aston-Martin, Berkeley, Borgward, Elva, Ferrari, Lancia, Lotus, Maserati, Mercedes-Benz 300 SL, Morgan, OSCA, SAAB GT, Sprite.

**BUYER'S GUIDE TO LIMITED PRODUCTION CARS** (complete with spec sheets)—Abarth, Allard, BMW, Bristol, Cisitalia, Cooper, Dellow, DB, DKW, Elva, Facel Vega, Fairthorpe, Frazer-Nash, Gordini, Gregoire, Jensen, Jomar, Kieft, Lister, Lotus Elite, Moretti, Nardi, Pegasso, Salmson, Stanguellini, Talbot-Lago, Turner.

**BUYER'S GUIDE TO LIGHT CARS** (complete with spec sheets)—Alfa, Austin, Borgward, Citroen, DKW, English Ford, Fiat, Hillman, MG Magnette, Metropolitan, Morris, Opel, Panhard, Peugeot, Rambler, Riley, Renault, SAAB 93B, Simca, Sunbeam, Taunus, Triumph, Vauxhall, Volkswagen, Volvo.

**PLASTIC SPORTS CAR BODIES BUYER'S GUIDE**—Alken, Almquist, Devin, Victress, etc.

**SPORTS CAR ACCESSORIES AND TIRES** — a thorough round-up of new products in the field.

**SERVICE DIRECTORY** — a complete listing of dealers all over the United States who service sports cars and stock spare parts.

Once you see the 1959 SCI DIRECTORY, you'll agree that it's the greatest showroom of all—a breathtaking panorama of the wonderfully exciting world of imported cars! Sports car fans won't want to miss this Ziff-Davis publication.

**THE SPORTS CARS ILLUSTRATED DIRECTORY**  
goes on sale soon. Watch for it—only \$1.00.

can assemble an instrument that can be used as a direct-reading a.c./d.c. voltmeter and as an output meter.

The completed instrument may be calibrated by the same technique used with the

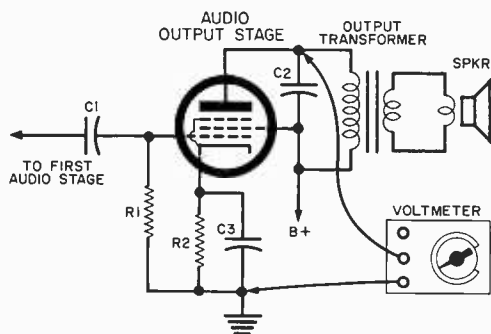

Correct method of connecting the volt-output meter to the last audio stage of an amplifier.

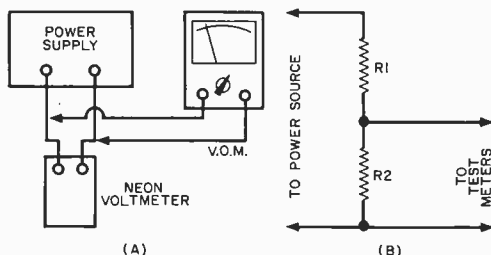

Voltmeter calibration procedure using (A) variable power supply and (B) a voltage divider.

pulse rate voltmeter. To make each reading, the control ( $R1$ ) is set all the way back, then advanced gradually until the neon bulb just lights. Separate readings are obtained as different voltages are applied to the instrument.

If you don't have an adjustable output power supply, you can use a fixed B voltage supply and a simple voltage divider consisting of two resistors totaling 250,000 ohms across the power supply output. A variable output voltage is obtained from the center tap and the ground side of the combination.

To use this instrument to measure d.c. voltages, connect to the "COM." and "DC" terminals. Adjust  $R1$  until the neon bulb just lights, then read the applied voltage on the dial. The polarity of the applied voltage can be identified by noting which of the two electrodes (in the neon bulb) lights—this is always the *negative* electrode.

For a.c. voltage measurements connect the "COM." and "AC" terminals. *Both* electrodes light on a.c.

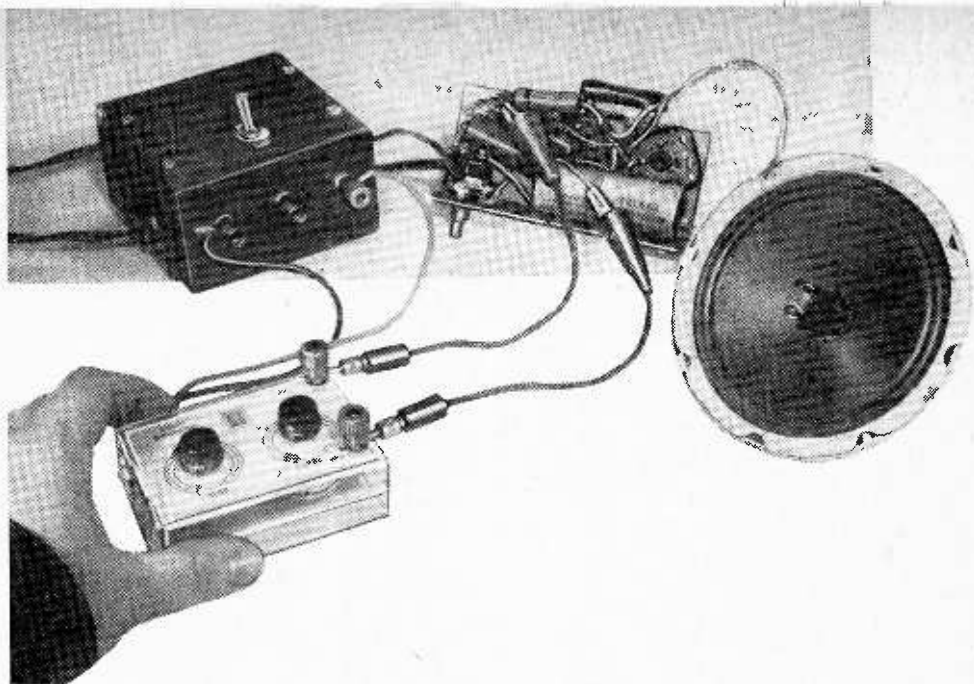

by e. g. louis

All electronic equipment that feeds earphones or loudspeakers contains stages which handle the audio signal. Our receivers, whether old or new, AM, FM or TV, all include audio amplifier stages. So do all audio systems, from hi-fi types to intercoms. For testing newly completed projects or repairing old ones, the audio generator is a very useful instrument.

As you know, commercial audio generators are usually large and fairly expensive bench-type instruments. They supply low-distortion sine-wave signals over a wide range of frequencies and with excellent frequency calibration. Such instruments are needed for *precise* measurements or tests.

However, for servicing and signal-injection trouble-shooting techniques, we don't need a "perfect" sine wave. What we do need is a test signal with a frequency in the middle of the audio range and an output variable from near "zero" to about a volt.

You can construct a midget audio generator in a single evening which will meet these basic requirements. Truly "pocket-sized," the completed instrument is not much larger than a package of cigarettes. It can be operated from the equipment under test or from its own power supply. A versatile separate power supply circuit will be discussed later in this article.

# Pocket Size Test Instruments

## Part 2

*simple audio generator helps  
you to trace a signal through  
amplifier stages*

**Internal view** of generator shows parts layout. When drilling lead and component holes, do not use excessive pressure on the brittle plastic. When soldering to the lugs, take care not to melt the cabinet. Schematic below shows method of obtaining low impedance output.

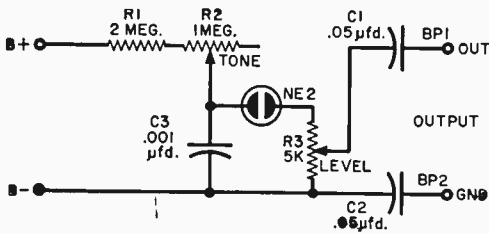
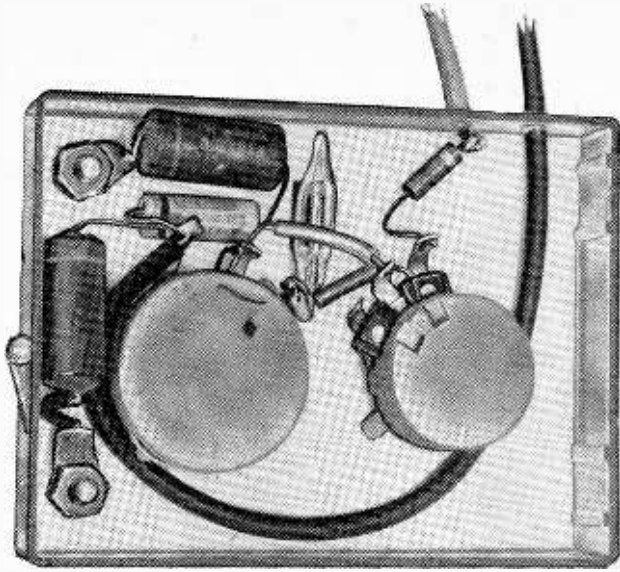

### parts list

- BP1, BP2—Binding posts
- C1, C2—.05- $\mu$ fd., 400-volt miniature capacitor
- C3—.001- $\mu$ fd., 400-volt capacitor (see text)
- R1—2-megohm,  $\frac{1}{2}$ -watt resistor
- R2—1-megohm potentiometer (Tone)
- R3—5000-ohm potentiometer (Level)
- 1—NE-2 neon bulb
- 1—small plastic box or metal case
- Misc. knobs, machine screws and nuts, wire, solder, etc.

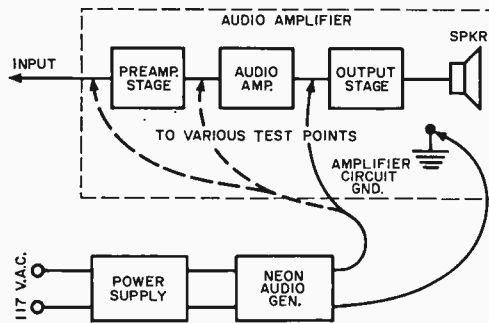

Interstage test points will enable rapid trouble-shooting of audio stages in hi-fi equipment or receivers.

### audio generator

This audio generator will supply a pulse-like signal at a moderately low output impedance. A neon bulb is used instead of a tube or transistor. And two controls are provided to adjust amplitude and frequency for special tests.

The NE-2 neon bulb is employed in a relaxation oscillator circuit and need not be visible as far as the use of the instrument is concerned. However, if you leave a cut-out in the housing so that the bulb can be seen, it will serve as an attractive pilot light.

Five-way binding posts (BP1, BP2) or any similar type of connector can be used for the output terminals. Two flexible leads are provided for connecting the instrument to a d.c. power supply source. These leads may be terminated in spade lugs, banana plugs, 'phone tips or small insulated alligator clips.

House the unit in a small plastic box or metal case. If you use a transparent plastic box, you can make an attractive front panel by drawing a dial layout on a piece of colored cardboard with black ink. Mount the cardboard tightly against the inside of the cover. Controls and output terminals may be labeled by hand or with a typewriter. If a metal case is employed, you can give the completed unit a professional appearance by labeling it with standard radio decals.

To use the instrument, first connect the

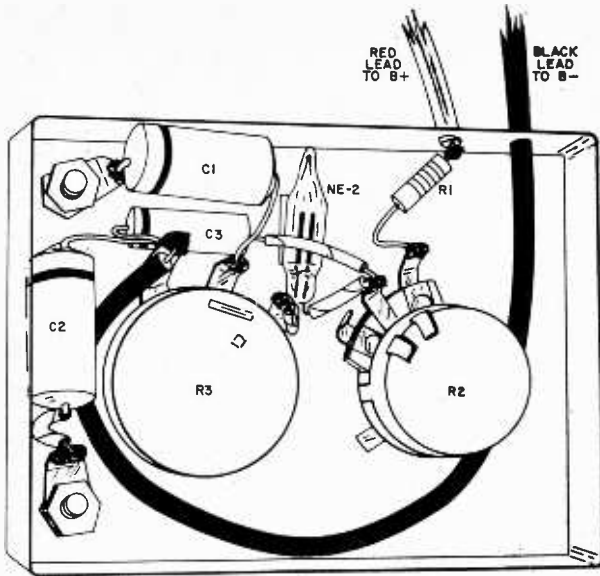

Completed generator is seen below. Neat control panel markings can be achieved by typing or hand lettering the appropriate markings.

B+ and B- leads to a suitable d.c. voltage source (95-150 volts). This may be the B supply of the equipment being checked, batteries, or a separate power supply. Then connect standard flexible test leads to the generator's output terminals and to appropriate points in the equipment under test. Adjust the frequency and amplitude controls as needed. The basic signal injection test technique is illustrated on page 138. With this approach, trouble-shooting audio stages is a "snap."

Connect the audio generator's *Gnd.* lead to the amplifier ground. Then connect the *Output* lead to the input of the amplifier's output stage. This may be either the grid of a vacuum tube or the base of a common emitter transistor amplifier stage. If the amplifier's power supply circuit and output stage are operating normally, an audio tone will be heard from the loudspeaker. Set the audio generator's *Level* control to the minimum level that will give an audible signal.

Next, transfer the generator's output signal lead to the input of the previous stage. Again, an audio tone should be heard from the loudspeaker, but with *increased volume*, due to the added gain of the second stage. Again reduce the generator's output level until the signal is just audible, and transfer the output lead to the input of the next preceding stage.

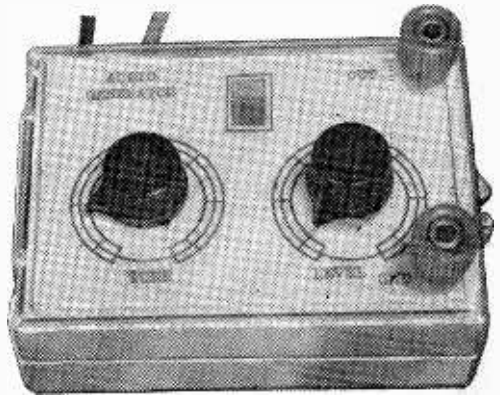

### how it works

This audio generator is basically a simple relaxation oscillator, modified to provide an output signal across a low-impedance load. Its output signal has a rounded waveshape instead of the usual saw-tooth waveform that a neon bulb oscillator produces.

In operation, a d.c. voltage (from 95 to 150 volts) is applied to the two power supply leads (B+ and B-). Capacitor C3 charges slowly through series resistors R1 and R2 until the voltage across it reaches the firing potential of the NE-2 neon bulb. Then the bulb fires and discharges the capacitor through the Level control (R3).

With C3 discharged, there is no longer sufficient voltage available to keep the neon bulb conducting, and it extinguishes, allowing the capacitor to recharge. This action keeps repeating, developing a signal voltage across R3.

Operating frequency is determined by the time constant of R1, R2 and C3 and by the applied voltage. Since R2 is variable, it serves as a Tone (or Frequency) control.

The setting of R3's center arm determines the portion of the available signal voltage that is applied to the two output terminals (BP1 and BP2) through isolating and d.c. blocking capacitors C1 and C2.

The power supply shown at right may be used for a number of purposes in addition to that of powering the generator. Schematic below includes a surge resistor and line isolation.

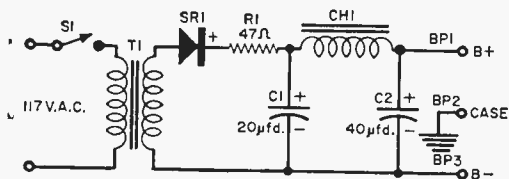
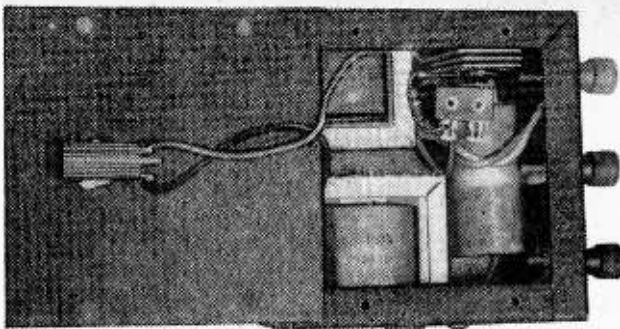

### parts list

BP1, BP2, BP3—Binding posts  
 C1, C2—20-40  $\mu$ fd., 150-volt, dual electrolytic capacitor  
 CH1—10-henry, 65-ma. filter choke  
 R1—47-ohm, 1/2-watt resistor  
 S1—S.p.s.t. toggle switch  
 SR1—65-ma. selenium rectifier  
 T1—1:1 isolation transformer, secondary rated at 65 ma. (minimum)  
 1—4" x 4" x 2" metal case (ICA No. 3810)  
 Misc. rubber feet, terminal strip, line cord and plug, machine screws and nuts, wire, solder, ground lugs, etc.

Continue this technique, stage by stage, until you reach the input of the amplifier. There should be an increase in volume as each stage is added to the amplifying chain. Stage gain is indicated by the relative increase in volume between adjacent stages. If there is a *drop* in volume, or if the tone disappears entirely, you have isolated the defective stage. The final step is to check operating voltages and components in that stage until you isolate the defective part or connection.

This basic servicing technique can be used both with factory-built equipment and for "debugging" home-built amplifiers. The investment made in components (about \$4.00) will be more than compensated for by the time and effort saved in servicing.

### power supply

Since the audio generator's current requirements are low, the d.c. needed to operate it may be obtained from the equipment (receiver, phono amplifier, etc.) being tested. Simply connect the B+ and B- leads to

### how it works

In operation, the rectifier circuit is isolated from the a.c. power line by transformer T1, S.p.s.t. switch S1, in the primary circuit, serves as an "on-off" switch. A single selenium rectifier stack (SR1) is used as a half-wave rectifier, with ripple filtering provided by a "pi" type LC filter, consisting of electrolytic capacitors C1 and C2, and iron-core filter choke CH1. A small series resistor (R1) serves to limit the surge currents as C1 charges, and thus protects the selenium rectifier against accidental burn out.

appropriate terminals in the equipment. Connection across the second filter capacitor will usually be correct.

However, many receivers do not have 90 volts or more of d.c. available in their circuits which we can borrow for powering the audio generator. Portable sets using 45- or 67-volt batteries and transistor sets are in this class, and a separate power supply for the audio generator is necessary when testing them. Some of you might want to employ the separate power supply at all times for convenience and for safety.

A suitable power supply circuit is shown at left. Supplying about 130 volts, d.c., this unit may be assembled from easy-to-obtain, low-cost parts in a single evening. Its exact output voltage will depend on the load. House the power supply in a standard 4" x 4" x 2" metal case, so that it will require relatively little space on the workbench or in the tool box.

By using a "shock-free" design with the chassis isolated from the power line circuit, you can also use this power supply as a *safe* substitute B supply for table model receivers, small phonograph amplifiers and portables. And, since *either* output terminal may be connected to circuit "ground," you can even use it as a negative bias supply for a moderate-sized radio transmitter.

by e. g. louis

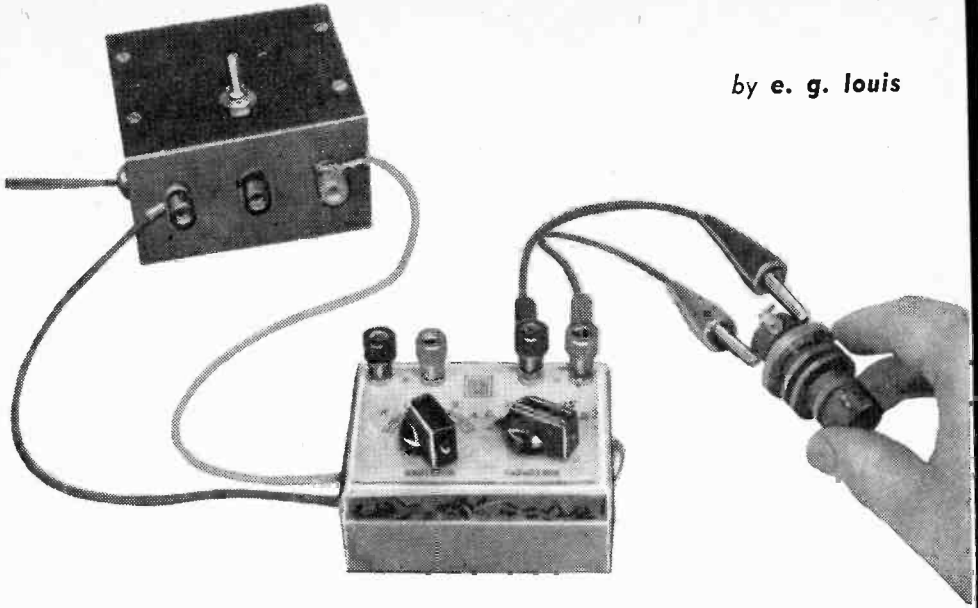

As resistors and capacitors make up the majority of electrical parts used in electronic equipment, it is important that both the home experimenter and service technician have adequate means for checking them. Resistors are usually checked with a standard ohmmeter which has a limited range, and few low-cost ohmmeters will give a usable reading at values above 500,000 ohms or 1 megohm. Yet 2 to 20 megohm resistors are encountered frequently in receivers and amplifiers.

Except for electrolytics, capacitors, too, may be difficult to check with standard equipment. For example, a common defect of medium-sized bypass and coupling capacitors is "high leakage," i.e., the capacitor's insulation breaks down and the unit *acts* as if a high resistance were shunted across it. The leakage resistance may be on the order of several megohms—low enough to cause considerable trouble, but not low enough to show up on a standard ohmmeter test.

A simple and easy-to-build RC tester can be used to check high resistance values (to 20 megohms or more) and medium-sized paper and ceramic capacitors (0.02 to 1.0  $\mu$ fd.) for *both* capacitance and leakage. It can be used as a continuity checker for checking low-value resistors, coils and transformer windings . . . for checking for

# Pocket Size

## Test Instruments

### Part 3

*easy-to-build unit will  
check and measure  
resistors and capacitors*

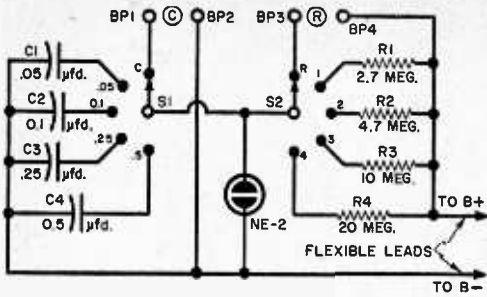
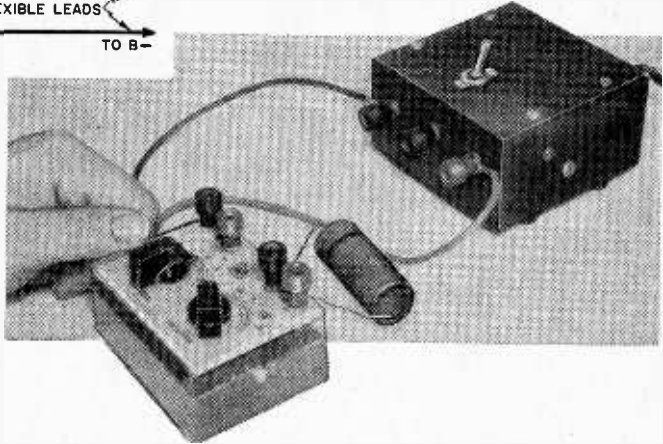

Fig. 1. Schematic diagram of the simple RC tester. Resistors should be of 5% tolerance and the capacitors should be good-quality, low-leakage types to insure proper functioning of the instrument.

### parts list

- BP1, BP2, BP3, BP4—Binding posts
  - C1—0.05- $\mu$ fd., 200-volt capacitor\*
  - C2—0.1- $\mu$ fd., 200-volt capacitor\*
  - C3—0.25- $\mu$ fd., 200-volt capacitor\*
  - C4—0.5- $\mu$ fd., 200-volt capacitor\*
  - R1—2.2-megohm,  $\frac{1}{2}$ -watt resistor
  - R2—4.7-megohm,  $\frac{1}{2}$ -watt resistor
  - R3—10-megohm,  $\frac{1}{2}$ -watt resistor
  - R4—20-megohm,  $\frac{1}{2}$ -watt resistor (or two 10-megohm units in series)
  - S1, S2—Single-pole, 5-position rotary switch
  - 1—NE-2 neon bulb
  - 1—Small plastic case
  - 2—Pointer knobs
- \*All capacitors are metalized paper units



A capacitor is shown being tested in the photo below.

insulation breakdown . . . and as an RC substitution box for some values of resistance and capacitance.

Easily assembled in a single evening, the construction of this pocket-sized instrument will cause a minimum of damage to your wallet. If you buy most of the components new, your total outlay shouldn't be over five dollars.

### construction

The model is housed in a small plastic box, but a metal or wooden case will serve as well. Shielding is not necessary.

Neither parts layout nor lead dress is critical, and you can either follow the general layout of the model or make up a new layout to suit your own requirements. Whichever you do, make sure that the NE-2 neon bulb is visible when the instrument is in a normal operating position.

Be especially careful when installing  $R1$ ,  $R2$ ,  $R3$ , and  $R4$  (Fig. 1). While any composition resistor might be damaged by excessive heat, high-value resistors are much more susceptible to heat damage than other units. Use a clean, hot, well-tinned soldering iron, and complete each connection as quickly as possible.

If you use a plastic box with a transparent top for a case, you can duplicate the panel of the model. With India ink, draw the dials on a piece of stiff cardboard which will just fit inside the box. Controls and terminals may be labeled by hand or with a typewriter. The completed panel is placed just *behind* the transparent cover and held in place by the mounted switches and other components.

While all the components specified are standard and should be readily available, not all local distributors stock small resistors above 10 megohms. If you are unable to buy a 20-megohm resistor ( $R4$ ) locally, you can connect two 10-megohm resistors in series to obtain this value.

Two flexible leads (B+ and B-) are provided for power supply connections. These may be from 12" to 24" long, and should be terminated in either spade lugs, alligator clips, phone tips, or similar connectors.



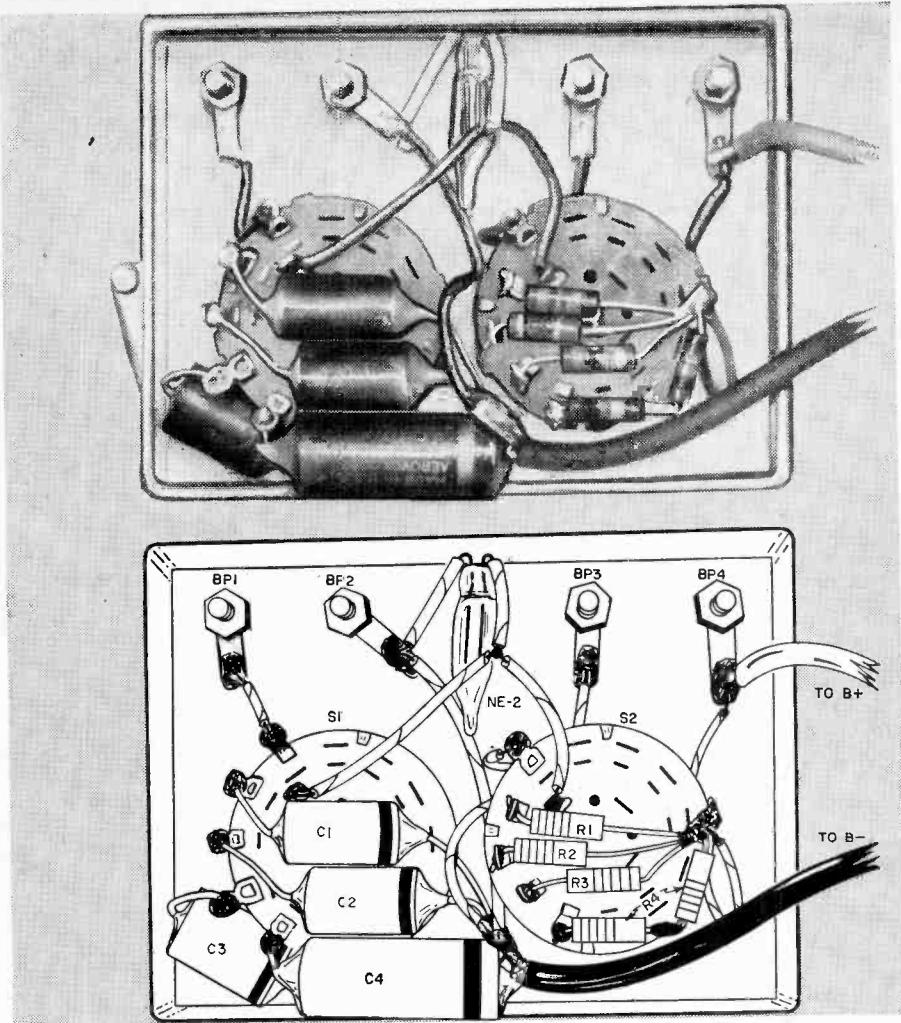

Interior layout for the resistor and capacitor tester.

### how it works

In use, the power leads (B+ and B-) are connected to a d.c. voltage source supplying from 100 to 150 volts. This can be an experimental power pack, a set of batteries, the B supply of a small receiver or amplifier, or the small power supply which was described in the February issue on page 48.

The RC tester can be used in any one of several ways. When checking capacitors or high value resistors, the instrument operates on the principle of dynamic substitution. This technique can be explained best by reference to the equivalent circuit diagram in Fig. 2.

Initially, the Capacitor switch (S1) is set to select one of the fixed capacitors (C1 to C4), while the Resistor switch (S2) is set to select one of the fixed resistors (R1 to R4). With the switches set in this way, and the power supply leads connected to an appropriate voltage source, the unit becomes a simple relaxation oscillator having known values of R and C.

In operation, capacitor C is charged slowly through series resistor R until the voltage across the capacitor equals the firing voltage of the neon bulb (about 60-80 volts), at which time the bulb fires and acts essentially like a short circuit,

discharging the capacitor. With the capacitor discharged, the voltage across it drops below the value needed to keep the NE-2 neon bulb conducting and the bulb is extinguished. The capacitor can then recharge through the resistor.

This action keeps repeating, with the bulb lighting or "blinking" each time it fires. The repetition rate depends on the RC time constant and on the supply voltage, and is slow enough so that individual "blinks" may be observed.

If an unknown resistor RX is substituted for the known resistor R, and the "blinking rate" increases (more blinks per second), then the unknown resistor is lower in value. Similarly, if the blinking rate decreases (fewer blinks per second), the unknown resistor has a higher value than the known resistor R. The increase or decrease in the blinking rate is proportional to the relative sizes of the two resistors.

The value of an unknown capacitor CX can be checked in a similar fashion, by substituting it for the known capacitor C, and noting the increase or decrease in the blinking rate. An increase in blinking rate results if the unknown capacitor is smaller than the known capacitor, and vice-versa.

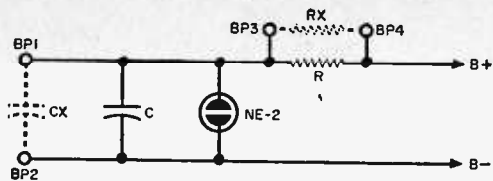

Fig. 2. Schematic breakdown of RC tester circuit when used to check either resistors or capacitors.

With the wiring completed, recheck the circuit for possible errors, accidental shorts, or poorly soldered connections *before* connecting the instrument to a power source or attempting to use it.

### operation

With a selection of known resistor and capacitor values, it is possible to estimate the value of unknown capacitors and resistors with a good degree of accuracy, wherever the capacitor value falls between 0.02 and 1.0  $\mu$ fd. or the resistor value falls between 1 and 40 megohms. If the unknown capacitor is *open*, or has a very low value, the neon bulb will appear to glow continuously. If the unknown capacitor is *shorted*, the neon bulb will not light or blink. (See Fig. 2, at top of page.)

Since a leaky capacitor acts like a high-value resistor, a suspected unit is checked in the same way that a high-value resistor is checked—by substituting it for the known resistor ( $R$ ). If the capacitor is "good" as far as leakage is concerned, the neon bulb either will not blink (fire) or will blink only once. A suspected breakdown in insulation may be checked in a similar fashion.

When used to make *continuity* measurements and to check low value resistors, the instrument operates as a simple *neon bulb indicator* (Fig. 3). The d.c. supply voltage is applied to the NE-2 neon bulb through one of the fixed resistors ( $R$ ) which serves to limit the current to a safe value. Test leads are connected to the  $C$  terminals BP1 and BP2 and *Capacitor* switch  $S1$  is set in the  $C$  position.

In operation, the neon bulb continues to glow as long as the circuit to which the test leads are connected is open or has a very high resistance. If the circuit has low resistance, as will be the case when checking a small coil or transformer, for example, the bulb is extinguished, since the circuit being tested acts as a short across the bulb.

### testing

The technique to use depends on the tests you want to make. For all standard tests, however, the first step is to connect the flexible power supply leads to a source of d.c. voltage (100-150 volts). Then you can follow the individual steps outlined below.

**High Value Resistance.** Connect the unknown resistor to the  $R$  terminals BP3, BP4. Set *Capacitor* switch  $S1$  to the 0.05- $\mu$ fd. position. Turn the power supply on and note the rate at which the neon bulb "blinks" with *Resistor* switch  $S2$  in the  $R$  position. Gradually rotate  $S2$  until you find a value of fixed resistance which gives approximately the same blinking rate as the unknown. This is the value of the unknown resistor. If the blinking rate is too high to follow, try a larger value capacitor by resetting  $S1$ , and repeat the test.

If the neon bulb fails to light, the unknown resistor is *open*. If the blinking rate is about twice that of the smallest test resistor used, then the unknown resistor is about half that value. Similarly, if the blinking rate is about half that of the largest test resistor used, the unknown resistor is about twice that value. If the blinking rate falls *between* the rates obtained with two of the test resistors, the unknown resistor has a value falling between the two. For example, if  $RX$  gives one blinking rate, with the rate obtained with the 4.7 megohm resistor being *higher* than that of the unknown but the rate obtained with the 10-megohm resistor *lower* than that of the unknown, the unknown has a value of about 6 or 7 megohms.

**High Leakage Resistance.** Use the above technique but connect the unknown *capacitor* to the  $R$  terminals.

**Insulation Leakage.** Again use the technique employed for checking a high-value resistor, but connect the flexible test leads

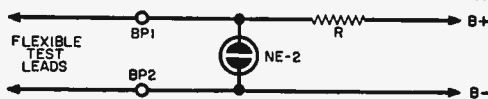

Fig. 3. When the instrument serves as a continuity checker, the test circuit is arranged like this. to the  $R$  terminals. For example, if you wanted to check the insulation between a transformer winding and its core, one of the test leads would be connected to the core of

the transformer, the other lead to one side of the winding being checked.

**Values of Capacitors.** Connect the unknown capacitor to the *C* terminals *BP1*, *BP2*. Set *S2* to one of the fixed resistor positions. Turn the power supply on and note the rate at which the neon bulb "blinks" with *S1* in the *C* position. Gradually rotate *S1* until you find a value of fixed capacity which gives approximately the same blinking rate as the unknown. This is the value of the unknown capacitor.

If the neon bulb *fails* to light or blink, the unknown capacitor is *shorted*. If the neon bulb lights continuously, or if the blinking rate is too rapid to follow, the capacitor is either open or has a low value. Try other fixed resistors (by adjusting *S2*) and repeat the test.

If the blinking rate is twice that of the smallest test capacitor used, the unknown capacitor is about half that value. Similarly, if the blinking rate is half that of the largest test capacitor used, the unknown is about twice that value. If the blinking rate falls between those obtained with two of the test capacitors, the unknown capacitor has a value between the two.

**Intermittent Components.** If the unknown component (resistor or capacitor) is suspected of having an intermittent defect, try moving its leads back and forth while testing. An intermittent condition will show up as a change in the blinking rate.

**Continuity Tests.** To use the RC tester for continuity tests, connect a pair of test leads to the *C terminals* (*BP1*, *BP2*) and set *S1* in the *C* position. Set *S2* in one of the fixed resistor positions and turn the power supply on. The test leads are connected across the terminals or leads to be tested. If the circuit is open, the neon bulb will *remain lighted*. If the circuit is continuous, the neon bulb will go dark.

**Other Tests.** As you gain experience, you should be able to perform many special tests. For example, you can use the tester as a *resistor substitution box* for any of the fixed resistors included in it, or as a *capacitor substitution box* for the fixed capacitor values, as long as the voltage impressed across the capacitor does not exceed the "firing voltage" of the neon bulb.

1959 Edition

out in  
February!



## POPULAR PHOTOGRAPHY'S BRAND NEW GUIDE to 35-MM PHOTOGRAPHY!

Here for the first time is a complete guide to 35-MM, prepared by the editors of POPULAR PHOTOGRAPHY, the world's largest selling photo magazine. If you now own a 35-MM camera or plan to buy one soon, this new Annual will be invaluable to you. It will show you how to make the best use of your camera, how to take better pictures, what to look for when buying 35-MM equipment. In short, you'll find everything you want to know about 35-MM photography in six big sections covering

**THE 35-MM CAMERA**—What can you get for \$100? Rangefinder vs. Reflex. What you should know about interchangeable lenses. How good are coupled exposure meters? How to test a 35-MM camera. Buyer's guide to 35-MM cameras.

**THE 35-MM TECHNIQUE**—Are you getting the most from 36 exposures? How fast is your draw? How to be a human tripod. Professional tips on 35-MM developing and printing. Developing by inspection. How to make giant contact sheets.

**THE COLOR CAMERA**—Understanding color filters. A slide show is a picture story. Adding sound. Buyer's guide to slide projectors.

**THE 35-MM CAMERA AT WORK**—Text and pictures by outstanding photographers, demonstrating the 35-MM camera's amazing versatility.

**35-MM ACHIEVEMENTS**—A portfolio of outstanding 35-MM pictures showing the best and latest work being done with a miniature camera today. Each picture is accompanied by complete technical data and critical analysis.

**FACTS FOR REFERENCE**—Charts, tips, data, and tables designed for clipping and filing—all covering important 35-MM subjects.

**PLUS: BOB SCHWALBERG ON 35-MM**—a 40-page complete guide to miniature photography by the leading writer and technician in the field.

The POPULAR PHOTOGRAPHY  
35-MM ANNUAL

is on sale in February. Only \$1.00  
Be sure to pick up your copy!

ZIFF-DAVIS PUBLISHING COMPANY  
434 South Wabash Avenue, Chicago 5, Illinois

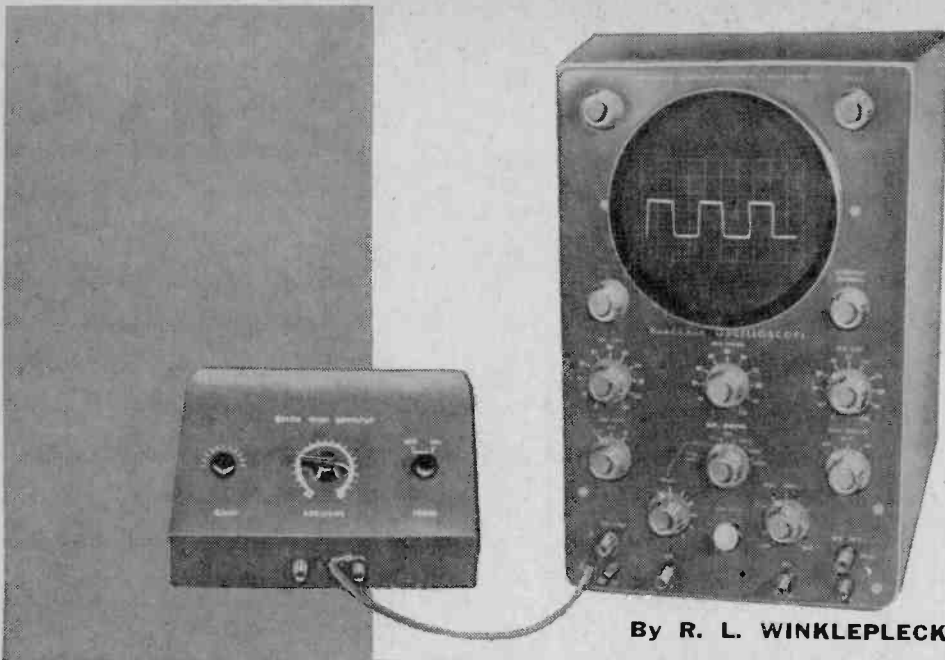

By R. L. WINKLEPLECK

# Build a SQUARE-WAVE GENERATOR for Audio Tests

Here's another item to add to your economy-built shop equipment. It's a practical, workable square-wave generator, complete with only two tubes. If you construct or service equipment, a square-wave generator is a must, for the use of square waves affords a rapid and simple means of checking audio amplifier performance.

A square-wave signal is applied to the amplifier under test and the amplifier output is examined with an oscilloscope. If the amplifier performance is good, the output wave-shape will be as square as the input—varying only in amplitude. Defective performance will cause distortion of the squareness, and

*Check your hi-fi equipment with a simple two-tube signal source*

Diagrams and parts list for the square-wave generator. Output control R8 may need to have its two outside terminal leads reversed for maximum clockwise gain.

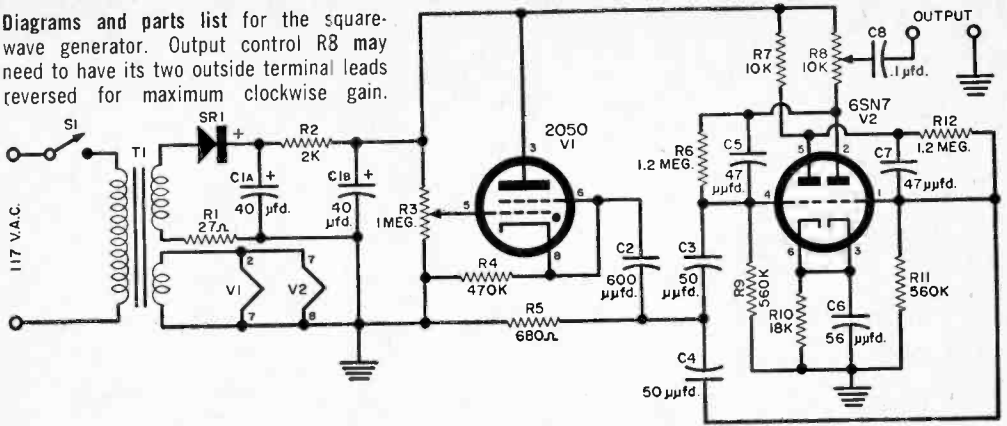

### parts list

C1a/C1b—40-40  $\mu$ fd., 150-volt dual electrolytic capacitor  
 C2—600- $\mu$ fd. mica capacitor  
 C3, C4—50- $\mu$ fd. mica capacitor  
 C5, C7—47- $\mu$ fd. mica capacitor  
 C6—56- $\mu$ fd. mica capacitor  
 C8—0.1- $\mu$ fd., 400-volt tubular capacitor  
 R1—27-ohm, 1-watt resistor  
 R2—2000-ohm, 1-watt resistor  
 R3—1-megohm linear potentiometer  
 R4—470,000-ohm, 1-watt resistor  
 R5—680-ohm, 1/2-watt resistor  
 R6, R12—1.2-megohm, 1/2-watt resistor

R7—10,000-ohm, 1-watt resistor  
 R8—10,000-ohm wire-wound potentiometer  
 R9, R11—560,000-ohm, 1/2-watt resistor  
 R10—18,000-ohm, 1-watt resistor  
 S1—S.p.s.t. switch  
 SR1—65-ma. selenium rectifier  
 T1—Power transformer (Stancor PS8415 or equivalent)  
 V1—Type 2050 tube  
 V2—Type 6SN7 tube  
 1—6" x 4" x 1" aluminum chassis  
 1—7" x 4 1/2" x 4 1/4" sloping-panel cabinet  
 Misc. 5-way binding posts, terminal lugs, etc.

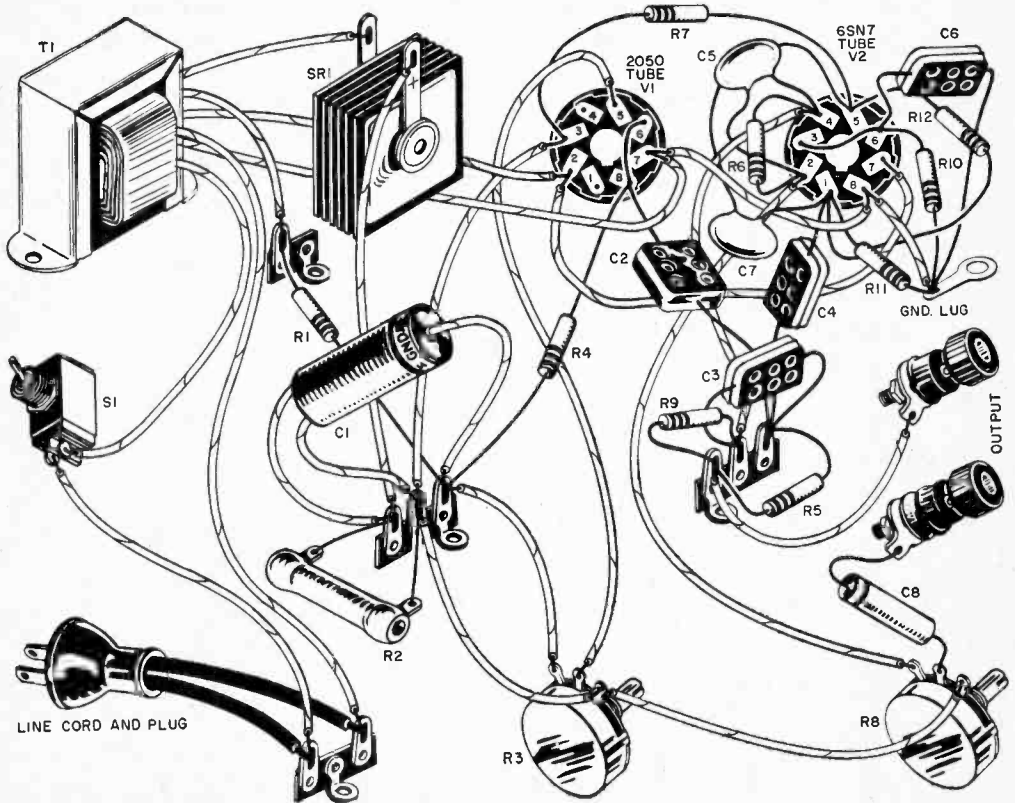

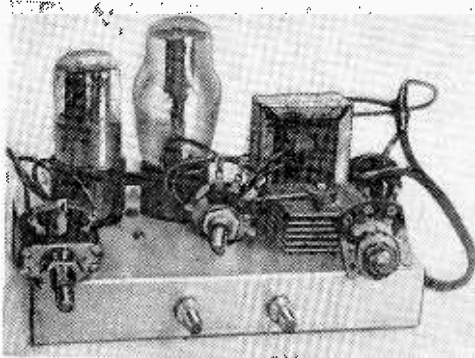

Top view of completed generator chassis removed from cabinet. Controls mount in appropriate holes cut in front panel.

the form of this distortion tells the initiated much about the amplifier.

Frequency of the generator to be described here is variable from less than 100 to over 2000 cycles per second and output can be varied up to approximately 40 volts peak to peak.

Using the components shown, this generator will produce square waves varying in frequency from 400 to 1800 cps. The lower frequency limit can be dropped by *increasing* the capacitance of *C2* or the resistance of *R4*. Conversely, the upper frequency limit can be raised by *reducing* *C2* or *R4*. If an extremely wide range of frequencies is desired, provision can be made in the design to switch any one of several resistors or capacitors.

The model is assembled on a 6" x 4" x 1" aluminum chassis which slips into a 7 $\frac{1}{2}$ " x 4 $\frac{1}{4}$ " sloping-panel cabinet. Output posts are mounted on the chassis and slip through holes in the cabinet drilled oversize to provide adequate clearance. The two potentiometers and the switch are mounted on short leads which are brought through the chassis and protected by rubber grommets. These controls are easily fastened in place on the cabinet as the chassis is slid into position. Two screws hold the chassis from beneath.

A conventional selenium rectifier power supply uses a transformer to isolate the circuit from the power line. This is always important for test equipment that must be connected to other equipment which may not be so isolated. The filament winding of the transformer specified is operated at 100% overload, but this causes no serious over-heating and the resultant lower filament voltage probably adds stability to the circuit.

It will not be necessary to calibrate the generator if the horizontal sweep of the oscilloscope with which it is used is calibrated. If such is not the case, however, both the scope and the square-wave generator can be quickly calibrated as follows:

Feed the 60-cycle voltage from a 6.3-volt source to the vertical input and adjust scope sweep to show one complete sine wave. The scope is now sweeping at 60 cycles. Attach the output and, with the frequency control on the generator, stabilize five square waves on the scope screen for a generator frequency of 300 cps or ten square waves for 600 cps. From this base frequency, it's possible to work both ways and calibrate both generator and scope at 100-cps points throughout its range.

The waveshape of this generator is very good for such an economical unit. Rise time is straight up and down, and the horizontals have only the faintest suggestion of a slope. The only obvious deviation is a slight rounding of the leading edge of the square wave such as is associated with loss of higher-frequency harmonic signals. This is slight, however, and does not seriously mask such a condition in an amplifier which is under test.

## how it works

This circuit is basically a bi-stable multivibrator using a duo-triode tube, i.e., a two-stage amplifier with the output of one stage RC-coupled directly to the input of the other. A bi-stable type is designed so that one triode is full on while the other is full off and it is stable in either position. A trigger, properly applied, causes the "off" and "on" states to switch back and forth. This change takes place virtually instantaneously, so that the waveshape at the plate of either section is a square wave with a rise time so short it hardly records on the oscilloscope.

The trigger for the multivibrator is somewhat unusual. It's a type 2050 gas control tube used as a relaxation oscillator. *R4* and *C2* determine the time constant; but, by varying the grid bias with potentiometer *R3*, the pulse frequency can be varied over a relatively wide range. The peaked pulse output of the relaxation oscillator is fed, simultaneously, through capacitors *C3* and *C4* to the two grids of the multivibrator. These positive pulses have no effect on the grid of the conducting section since it is already positive but cause the grid of the non-conducting or cutoff section to swing abruptly positive, and this section immediately goes to full conduction while the other is cut off. The following pulse swings the multivibrator sections back again and the two pulses have thus produced one complete cycle of the multivibrator and formed one square wave. This square-wave output is taken from plate potentiometer *R8*, which controls the output gain. Capacitor *C8* in the output prevents loading of the circuit.

## section VII

### for your ham shack

simple r. f. meter	<b>150</b>
check your a.c. calibrator	<b>152</b>
semiconductor space spanner	<b>154</b>
card file transmitter	<b>158</b>



# **Simple R.F. Meter**

*measure r.f. output of the transmitter in your ham shack*

*. . . or use this meter in a dozen other ways*

This inexpensive r.f. indicator has a wide variety of uses around the ham shack or mobile radio installation. It can act as an absorption frequency meter (if calibrated), a field strength meter, neutralization indicator, or modulation monitor with phones. However, the main job of the model shown is to indicate proper antenna loading for my "minified" mobile transmitter.

It is relatively simple to put together, and nearly any low-priced transistor will work well. However, for maximum sensitivity, a transistor with a *beta* (current amplification) of between 25 and 45 should be used.

## **construction**

A  $3\frac{3}{4} \times 3 \times 2\frac{1}{8}$ " aluminum chassis houses all parts. The coil (*L1*) is tapped and connected to switch *S1* before installation in the box to facilitate soldering. Then the coil is cemented to the box by its plastic support.

Care should be taken in soldering the crystal diode (*CR1*) into the circuit by "heat sinking" the connections with a pair of long-nose pliers. A socket should be used for the transistor.

Fasten the 1½-volt cell to the chassis with household cement. With normal use, it should last almost its shelf-life.

After the unit is turned on, zero the meter with potentiometer *R3* in the collector circuit. Attach a small wire to the input binding post on the rear of the box which feeds r.f. to

The simplicity of the r.f. meter circuit (see schematic on next page) makes for ease of layout on the chassis (below). Number of turns tapped on *L1* for each band is indicated on the schematic. Finished meter is shown at top of next page.

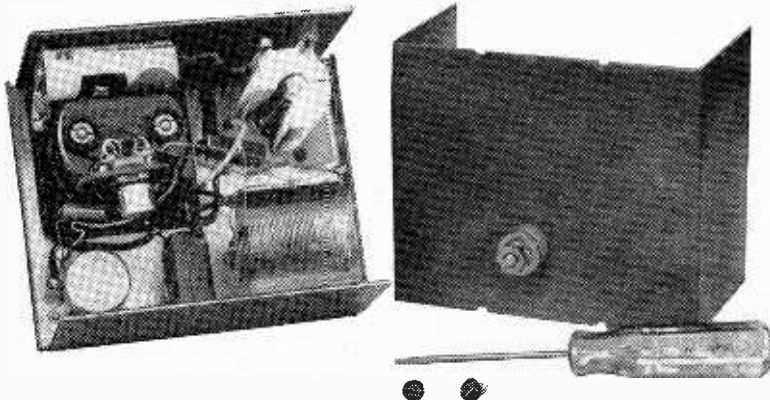



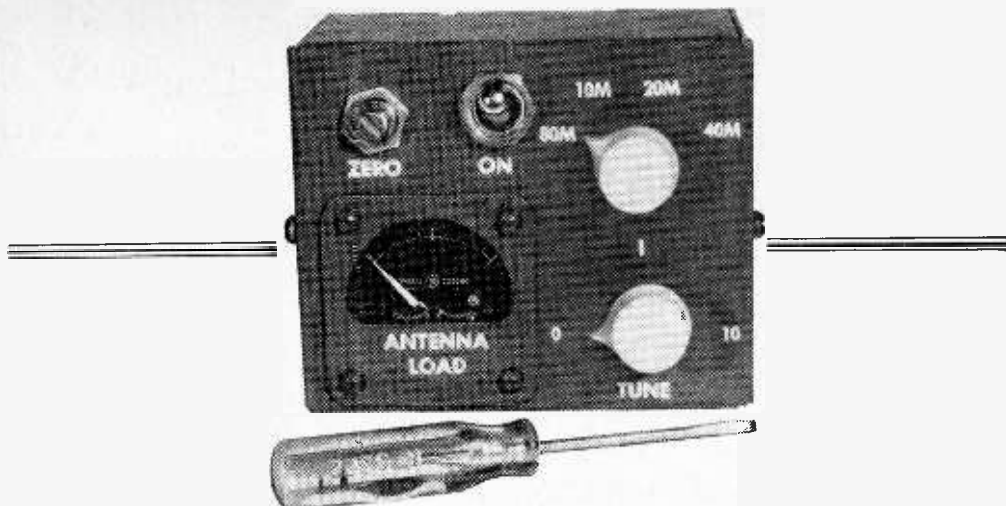

by charles j. schauers

the tuned circuit, and you are in business.

If the device is to be used as an absorption frequency meter, it can be calibrated with a heterodyne frequency meter coupled to the input post through a 500- $\mu$ fd. capacitor.

A 2½" length of wire is sufficient for r.f. pickup when checking oscillator, doubler or buffer and final amplifier stages of a transmitter.

When using the indicator as a field strength meter to adjust a beam antenna, the pickup wire length will depend upon the distance from the antenna and how much power is being applied from the transmitter's final amplifier. Usually, a 2" piece of wire will afford sufficient pickup at 100 feet.

To provide some attenuation of very strong signals, the indicator can be used harmonically. Set the bandswitch to 40 meters to measure carrier strength on 80 meters.

As a means for tuning mobile or fixed transmitters (especially those employing *pi*-output-networks), this unit enables one to determine very quickly if the antenna and not the *pi*-network is taking the load. For mobile operation, the regular auto broadcast antenna can be used for signal pickup. However, the device should be harmonically operated because of the strong signal.

If you are interested in monitoring your modulation, a pair of magnetic phones can be connected in the collector circuit of the transistor with the meter and potentiometer disconnected. The phones are connected between battery minus and collector.

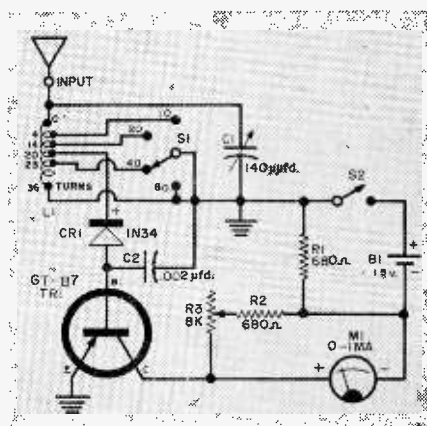

### parts list

- B1—1.5-volt D cell
- C1—140- $\mu$ fd. miniature variable capacitor
- C2—0.002- $\mu$ fd. mica capacitor
- CR1—Crystal diode (Sylvania 1N34 or equivalent)
- L1—#24-wire, 1"-diameter coil (Airdux 832T or B & W 3016—32 turns per inch, tapped as shown in schematic)
- M1—0-1 ma. d.c. meter
- R1, R2—680-ohm, ½-watt resistor
- R3—6500-10,000 ohm slotted shaft potentiometer
- S1—1-p., 4-pos. rotary switch
- S2—S.p.s.t. toggle switch
- TR1—Transistor (General Transistor GT-87 or GT-88 or Raytheon CK-721)
- 1—Aluminum chassis box (LMB-135)

### how it works

Radio frequency energy tuned by L1-C1 is applied to diode CR1. The rectified current then takes a path through the base-emitter circuit of transistor TR1. Current amplification occurs and is read by the 0-1 milliammeter. Capacitor C2, connected between the transistor base and ground, bypasses the radio frequency. The greater the strength of the r.f. signal picked up, the higher the reading on the meter.

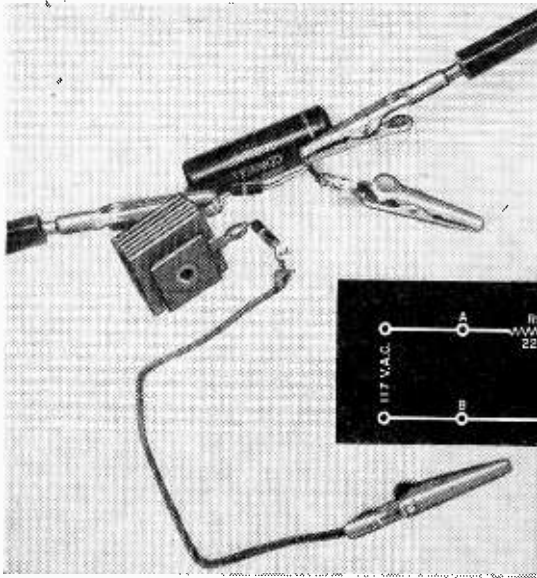

This simple circuit requires no chassis mounting. Lettered points in schematic of voltage source are explained in text.

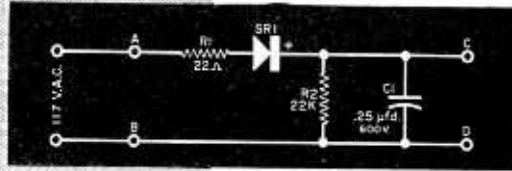

by james a. mc roberts

# Check Your A.C. Calibration

*achieve laboratory accuracy*

*with a four-component voltage source*

When you finish putting together that VTVM kit, are you stuck for a stable a.c. voltage source with which to adjust the calibration of the a.c. scales? Or when you are going to make some critical a.c. measurements, would you like to be able to recheck the accuracy of your VTVM or multimeter?

Calibration of the d.c. ranges of a meter is relatively simple since dry cells and batteries are universally available. Flashlight cells have an output voltage of 1.54 volts when new. "B" batteries are available in standard 45-, 67.5-, and 90-volt sizes for calibration of the higher voltage ranges in the B+ testing area.

Two 67.5-volt batteries, for example, can be connected in series to give over 135 volts for checking of the meter scale in the 150-volt section where many important measurements are made. (Actual voltage of each battery when fresh, measured with a VTVM, will be 69.3. The output voltage of a fresh battery is a physical constant and is dependent on the electrochemical makeup of the battery.)

Calibrating the a.c. ranges of the meter is a problem. The power line voltage which is your source of a.c. varies from instant to instant and from hour to hour. Another a.c. meter of *known* accuracy which is needed to check the power line and the a.c. scale is usually not readily available.

Here is a simple means of calibrating the a.c. ranges by means of the *previously calibrated* d.c. voltage ranges. All that's required is a simple half-wave rectifier system.

Use a 130-volt selenium rectifier (*SR1*) of 30-ma. or higher current rating, a 22-ohm surge resistor (*R1*), and a 22,000- to 47,000-ohm load resistor (*R2*). A 0.25- or 0.5- $\mu$ f.d. capacitor plus some wire and solder completes the parts list.

Measure the d.c. voltage across points *C*, *D* in the diagram on page 152. It almost equals the peak value of the a.c. voltage. Allow for about 1% drop through *R1* and *SR1*. Now switch your meter to its a.c. function and measure the a.c. voltage between *A* and *B*. Set the a.c. calibration control of your meter to read 0.7 (actually 0.707) of the previously measured d.c. voltage.

For example, if the d.c. voltage across *C*, *D* is measured as 160 volts (this would correspond to the *peak* a.c. voltage), then the a.c. r.m.s. voltage is 112 volts ( $160 \times 0.7$ ). Since the line voltage may vary from one moment to the next, switch back to the d.c. scale immediately after setting the a.c. calibration control. Recheck the d.c. reading, then switch back again to the a.c. scale to recheck the line voltage which may have shifted.

Certain precautions should be observed since this little gadget is operated directly from the a.c. line. Never touch the metal cabinet of your meter or uninsulated sections of the test probes and an external ground simultaneously. Make all connections and disconnections of your test clips or probes only when the calibration circuit is *not* plugged in.

Don't touch any water pipes and avoid damp floors when working on any device which has its common or B— return connected directly to the a.c. line.

## DEMAGNETIZING SCREWDRIVERS

Those annoying magnetized screwdrivers that are always picking up metal chips or that small screw at the wrong moment can be easily demagnetized using your soldering gun. With the gun operating, pass the screwdriver blade between the tip holders. The a.c. field set up between the holders is sufficient to do the job. —R. L. K.

**MORE THAN 600,000 ELECTRONIC HOBBYISTS,**

**EXPERIMENTERS, STUDENTS AND HI-FI FANS**

**WATCH FOR ADS LIKE THESE EACH MONTH!**

BEST Offer over \$15 buys my \$250 Zenith All-Transistor Trans-Oceanic Portable, Never Used Nathan, Suite 2018, 37 Wall Street, New York

"TRANSISTORS For Beginners." At last a treatment of transistors you can easily understand. Clearly describes in simple language transistor action, amplifier biasing, NPN and PNP transistors, etc. Completely diagrammed. A must for beginners. \$1.00 P. Polton, 3702 E. Oakwood, South Milwaukee, Wisconsin

FOR Sale Custom-built 70 watt Heathkit amplifier (W6M) guaranteed excellent published specifications \$135. Heathkit pieamp (WA P-3) Custom-built \$25. Farrell, Box 363, Michigan City, Indiana

These classified ads are typical of the hundreds that appear each month in the pages of RADIO & TV NEWS, POPULAR ELECTRONICS and HIFI REVIEW. They bring top-notch results! As the above advertisers can attest, there's no better spot for a classified ad in the field of electronics!

If you have used equipment or information or services to sell, you too will find the classified columns of Ziff-Davis electronics magazines to be perfect market places. Your ad will get results quickly and profitably.

*for complete details, drop a postcard to:*

**MARTIN LINCOLN  
BOX EH9  
Ziff-Davis Publishing Company  
One Park Avenue  
New York 16, New York**

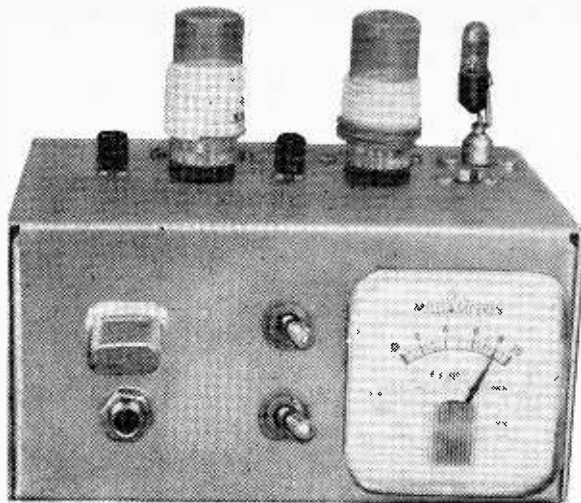

## The Semiconductor Space Spanner

*a challenge to your operating skill, this 96-milliwatt  
transistor transmitter operates on 15 and 10 meters*

*by don stoner, W6TNS*

Many amateurs, both Novices and old-timers, feel that it requires a lot of power to make contacts with foreign lands. The Novice longs for the time when he can discard the chains that bind him to the 75-watt power limit. And the old-timer dreams of a kilowatt rig to end all rigs.

Amateurs wise in the ways of propagation, and good operating techniques, know that this is not necessarily so. By taking advantage of good radio conditions and a snappy "fist," you can work wonders with low power, while the kilowatt may be bogged down by poor propagation.

You can prove this to your own satisfaction by constructing the "Semiconductor Space Spanner." It seems fantastic but this little giant is 750 times weaker than a typical Novice transmitter. The legal maximum for any transmitter is 10,000 times greater than the power input (96 milliwatts) for this rig! And yet the SSS transistor transmitter has logged an impressive list of contacts all over this continent and the Territory of Hawaii. Some of the contacts were pre-arranged, but many of them were the result of a 3 x 3 "CQ."

### **the crystal**

One might think that a transistor transmitter would be extremely expensive to construct. All the components except the quartz crystal were purchased for slightly over \$19.00. In buying the crystal, specify a third overtone type, and the frequency that you wish to operate on.

## how it works

"Drift" transistor TR1 is employed as an overtone oscillator. Bias and d.c. stabilization for TR1 are provided by resistors R1 and R2. Additional bias and stabilization are obtained in the emitter circuit by R3, which is connected in series with the key.

To stabilize the oscillator frequency, a quartz crystal is connected in series with the feedback path, between the collector and emitter. Oscillations appearing in the collector circuit are fed back to the emitter through the crystal and re-amplified. In this manner, the stage continues to oscillate.

The oscillator tank circuit, composed of L1, C2 and C3, resonates the crystal and also provides an impedance match to the power amplifier circuit. R.f. energy for driving the power amplifier is removed from the oscillator circuit at the low-impedance tap on coil L1.

Another drift transistor (TR2) is employed as the power amplifier. No d.c. bias is applied to this stage, however. The r.f. energy driving the base causes it to draw current on the negative peaks, thereby operating TR2 in true Class C.

Because the only bias for TR2 is obtained from the r.f., when the key is pressed, it draws no current until TR1 is oscillating. The output tank is resonated by C6 and is tuned to the operating frequency. The link and capacitor C7 match the amplifier tank to the antenna.

Both TR1 and TR2 are rated at 50 milliwatts dissipation. They can be operated at a much higher input because of the short duty cycle of Class C.

The power input to the final amplifier (in mw.) can be calculated by multiplying the voltage and the current (in ma.). This transmitter runs 8 ma. at 12 volts, which equals 96 milliwatts.

For Novice or General Class operation on the 15-meter band, you can use a 7-mc. crystal in this transmitter. The crystal is made to oscillate on its third overtone (harmonic mode). Its frequency will be "pulled" slightly because of the overtone operation.

As an example, a 7140-kc. crystal would produce a 21.420-mc. signal in an oscillator tripler circuit. In an overtone circuit such as is used in the SSS transmitter, this same crystal produces an output on 21.412-mc. or a difference of 8 kc.

If the third overtone of the crystal that you select comes out near the edge of the band, be extremely cautious and check the actual frequency with an accurate receiver or frequency standard.

## drilling and mounting

The first step is to lay out the holes to be drilled on the chassis. You can either mark the paper wrapper and save it for a template, or if you are careful, mark the chassis directly. Drill as shown in the chassis layout diagram. Remove all burrs from the holes, rub the chassis lightly with steel wool, and then spray on a thin coat of clear plastic.

Start mounting the components by installing the meter switch (S2) and the crystal socket. Mount the key jack (J1) with the lugs away from the open end of the chassis. Install the power switch (S1) with the lugs toward the large meter hole.

The transistor sockets must be modified. Paint a dot on one end with red fingernail polish, then count away from the red end and remove the second lug. Do this for both sockets. The pin "by itself" (near the red dot) is the collector, then a space, the shield, the base and finally the emitter. Mount the sockets by forcing the rings down until they lock on the socket ridges. The red dot (collector end) should point towards capacitor C7.

Mount coil sockets (L1 and L2) by sliding the rings down until they grip the socket and the chassis tightly. Pin 3 on both of these sockets also points towards C7.

Install the ground lug between capacitors C2 and C6, using 4-40 hardware. Mount the three variable capacitors (C2, C6, and C7) with 4-40 hardware, and position the stators toward the rear of the chassis. Mount J2 (antenna jack) in the remaining hole, with the smaller lug (ground lug) towards L2.

## parts list

- B1—12-volt battery (8 RCA VS034 penlight [or larger] cells connected in series)
- C1, C4, C5, C8—1000- $\mu$ fd. disc capacitor
- C2, C6—15- $\mu$ fd. variable capacitor (Hammarlund MAPC-15)
- C3—10- $\mu$ fd. disc capacitor (Centralab DD-100)
- C7—50- $\mu$ fd. variable capacitor (Hammarlund MAPC-50)
- J1—Closed-circuit key jack
- J2—RCA type phono jack
- L1, L2—See coil data at right
- M1—0-10 milliammeter (Shurite 8303)
- R1—10,000 ohms
- R2—47,000 ohms
- R3—180 ohms
- R4—3300 ohms
- S1—S.p.s.t. toggle switch (Cutler Hammer 8280K16)
- S2—D.p.d.t. toggle switch (Cutler Hammer 836377)
- TR1—Oscillator transistor (RCA 2N371)
- TR2—Amplifier transistor (RCA 2N370)
- Xtal—Third overtone crystal for the desired frequency (International Crystal FA-9)
- 1—Crystal socket
- 1—3" x 4" x 6" chassis (Bud AC-430)
- 2—Five-pin transistor sockets (see text)
- 2—Coil forms (Amphenol 24-5H) and sockets (Amphenol 785S5)
- 1—RCA type phono plug to fit J2 (for installation on antenna lead-in)
- 1—#49 pilot lamp (for testing)
- 2—Penlight battery holders

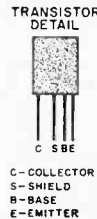
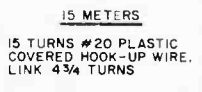
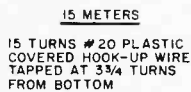
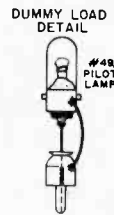
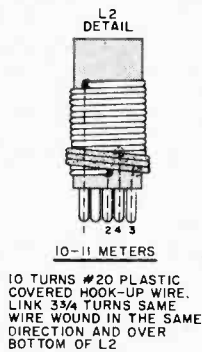
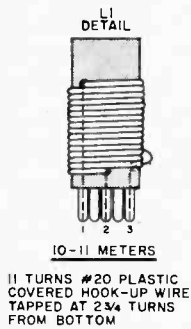
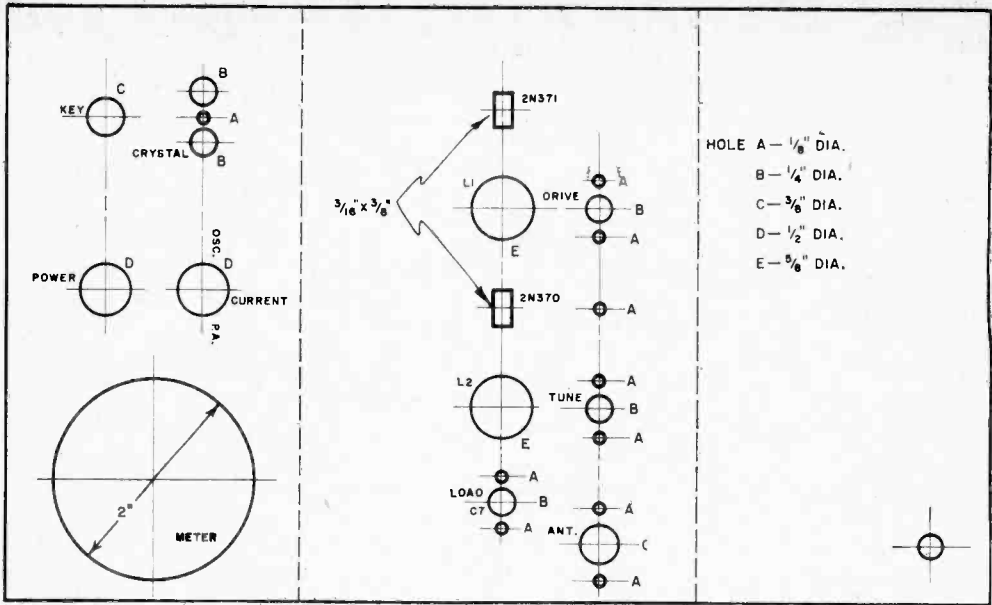

Layout of mounting holes above provides neat appearance and short leads required at these frequencies. Over-all size of chassis is optional with builder.

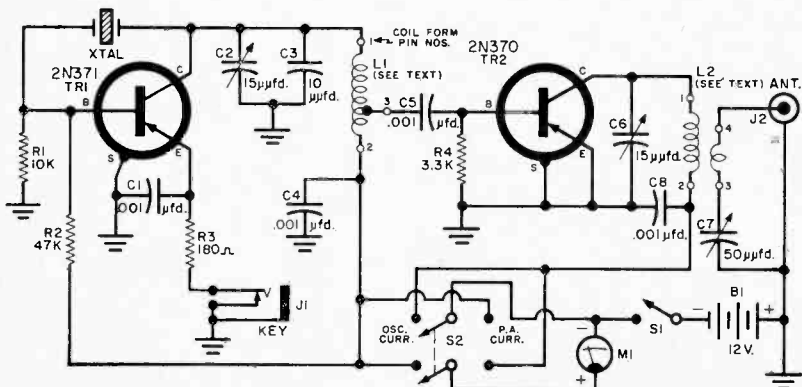

Mount the battery holders on the outside of the rear of the chassis with 4-40 hardware. Finally, install the 1/4" grommet in the hole on the rear apron. To avoid scratching the meter, do not mount it until the wiring is complete.

### coil construction

If you hold a Novice license, you must operate on the 15-meter band and need only one set of coils. However, if you have General Class privileges, you can operate on either 10 or 15 meters. The coil data covers both bands.

The coils are wound starting at the bottom, in a clockwise direction, while viewing the top. Holes should be drilled in the coil form directly above the pin to which the wire is connected.

### wiring

The transmitter should be wired up as shown in the schematic diagram. Keep the wires as short and straight as possible. Install the cells (B1) with the first one up, the second one down, the third one up, and so on. Connect them all in series by soldering wires between the positive terminal (brass tip) of one cell to the negative terminal (zinc base) of the adjacent cell.

Install the meter (M1) in the large hole on the front apron of the chassis, and connect it up (observe meter polarity). From this point on, you must be very careful not to scratch the meter face.

Before inserting the transistors (TR1, TR2), make some safety checks. Locate the wire between B1's cells and S1 (negative lead). Place the negative lead of a voltmeter (on the 15-volt scale) on this wire and connect the positive lead to the chassis. The meter should read slightly over 12 volts with fresh cells.

Make sure that S1 is off and insert the coils. Connect an ohmmeter between the chassis and the stator of C2 and C6 alternately. It should read infinity. If it does not, you have a short circuit. Assuming that the rig checks okay, let's fire it up.

### testing

With S1 still off, insert TR1 and TR2 in their correct sockets, insert the key in the jack, and install the crystal. Place S2 in the oscillator position, press the key intermittently, and turn S1 on. When the key is pressed, the meter should read between 5 and 8 ma. (depending on the setting of C2).

Switch to the "PA" position and check for current. It may read anything between zero and 10 ma. Adjust C2 to make the meter read maximum. Insert the test bulb load and set C7 for *minimum* capacitance. Adjust capacitor C6 for a dip in the collector current. It should read approximately 4.5 ma. at the "bottom" of the dip.

Slowly increase the capacitance of C7, while readjusting C6 for a dip, until the collector current reads 8 ma. You should now be able to observe that the pilot lamp filament is glowing at about half brilliancy. Once you have reached this point, you are ready to put the Semiconductor Space Spanner on the air.

### tuning and operation

Oscillator capacitor C2 is adjusted for *maximum collector current of the power amplifier*, rather than maximum grid drive as in a vacuum-tube transmitter. Power amplifier capacitor C6 is always tuned for *a dip in the power amplifier collector current*. Loading capacitor C7 is used to set the collector current of the power amplifier at 8 ma. when in the "bottom" of the dip. If your particular installation incorporates an antenna coupler, it is a good idea to tune it, in conjunction with loading capacitor C7, for maximum power.

It is best to tune up with a *field strength meter*. This would consist of a 0-1 milliammeter connected in parallel with a crystal diode. A wire from each meter terminal should be strung up near the transmitter antenna. Good hunting and choice DX!

by **donald a. smith**

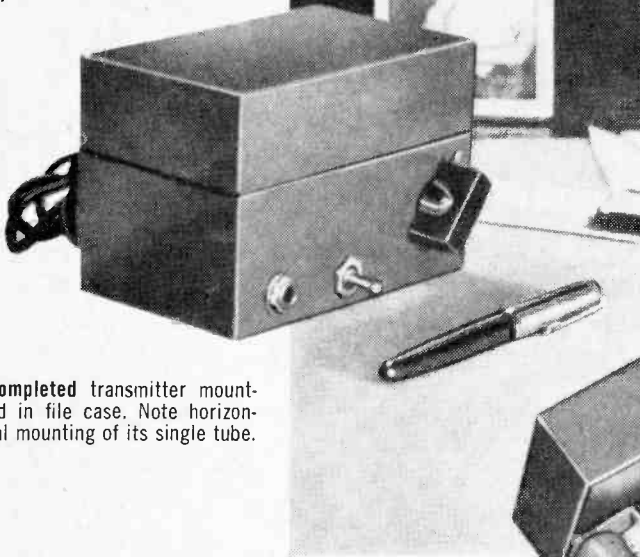

Completed transmitter mounted in file case. Note horizontal mounting of its single tube.

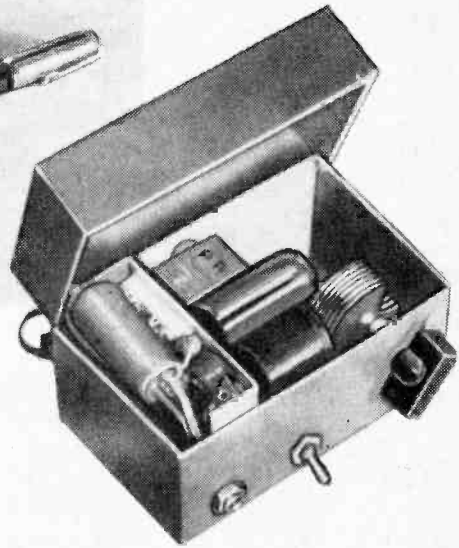
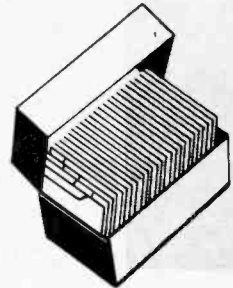

# card-file transmitter

This little file box contains more than just file cards. Enclosed please find one transmitter, complete with power supply! It will operate on both the 80- and 40-meter bands, and is crystal-controlled.

Power input of the "Card File" transmitter is about 6 watts. The rig has a jack for the key; when it is not in use, the key can be unplugged, leaving what appears at a glance to be an ordinary file box.

The oscillator is a modified Pierce circuit, which is easy on crystals. The plate circuit is tuned to the fundamental frequency, or can be tuned to the second harmonic. A 3.5+-mc. crystal, for example, could be used on 40 meters by tuning the plate-antenna circuit to the second harmonic.

Tube *V1* is a 117P7-GT which contains both a power amplifier and a rectifier section. A 117L7-M7-GT-G tube can be used instead if the difference in pin connections is observed. Both have a 117-volt filament, which can be connected directly across the a.c. power line.

*build a hideaway transmitter  
for standby and local use*



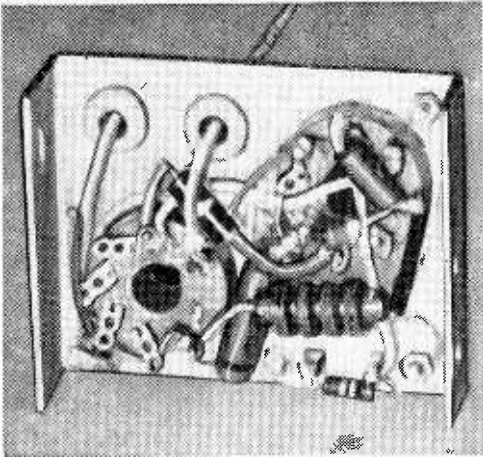

Simplicity of wiring is shown in bottom view of transmitter (above). Note "hot" ground in schematic below. Precautions are given in text.

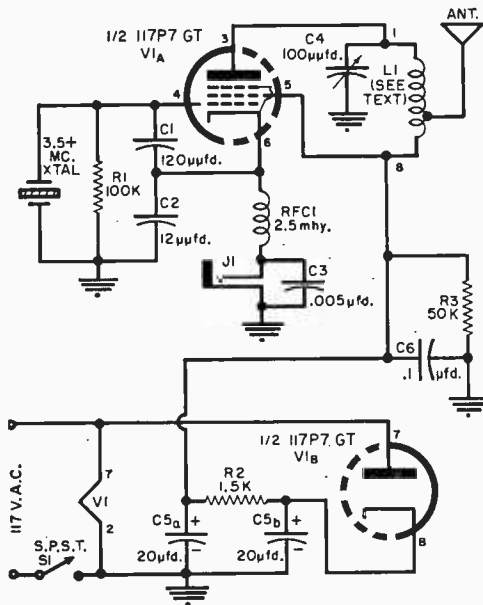

### parts list

- C1—120- $\mu$ fd. ceramic capacitor
- C2—12- $\mu$ fd. ceramic capacitor
- C3—0.005- $\mu$ fd., 600-volt capacitor
- C4—100- $\mu$ fd. variable capacitor (Bud 1855)
- C5a/C5b—20/20  $\mu$ fd., 250-volt dual electrolytic capacitor
- C6—0.1- $\mu$ fd., 600-volt capacitor
- J1—Midget phone jack
- L1—Coil (see text)
- R1—100,000-ohm,  $\frac{1}{2}$  watt resistor
- R2—1500-ohm, 1-watt resistor
- R3—50,000-ohm, 1-watt resistor
- RFC1—2.5-millihenry choke
- S1—S.p.s.t. switch
- V1—117P7-GT tube
- 1—Crystal and socket
- 2—Octal tube sockets
- 1—Index file card box (see text)
- 1— $2\frac{1}{2}$ " x  $4\frac{3}{4}$ " piece of  $\frac{1}{16}$ " or  $\frac{1}{32}$ " aluminum
- 3— $\frac{3}{8}$ " rubber grommets
- 1—Line cord and plug

### drilling and bending

Secure a  $2\frac{1}{2}$ " x  $4\frac{3}{4}$ " piece of aluminum either  $\frac{1}{32}$ " or  $\frac{1}{16}$ " thick. The chassis should be drilled *before* bending. See Fig. 1 for layout.

Mark the location of the holes, and center-punch them. Using a small bit, drill all holes. You will then have a guide or pilot hole for the larger bits. A  $\frac{5}{8}$ " tapered ream-

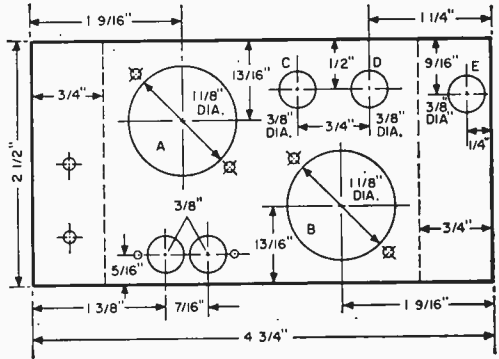

Fig. 1. Chassis template, top view. See text for explanation of details.

er may be used to make the holes larger. For the two octal sockets, drill and ream the holes to  $\frac{3}{8}$ " and then use a socket punch to finish them.

To bend the chassis, place two pieces of wood in a vise with the chassis between them. Adjust the wood so that one piece has its edge across the top and along the line where you wish to bend the chassis.

Bend the metal with your hand as far as you can, then take a rubber or plastic mallet and hammer the chassis until it is bent  $90^\circ$  while still in the vise.

Remove the chassis from the vise, turn it around, and bend the other end in the same manner. Both bends are in the same direction, the chassis forming a U shape.

Try the chassis in the cabinet for fit. If it does not fit well, adjust the bends.

Follow layout in Fig. 2 (p. 160) for the cabinet holes. The lower left-hand side of the cabinet with the hole for key Jack *J1* lines up with hole *E* in the chassis. Line up *J1* through both holes. This secures the front of the chassis to the cabinet. The two holes in the rear apron are used to secure the rear of the chassis to the cabinet. However, do *not* install the chassis yet, and do *not* mount *J1*.

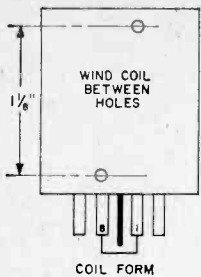
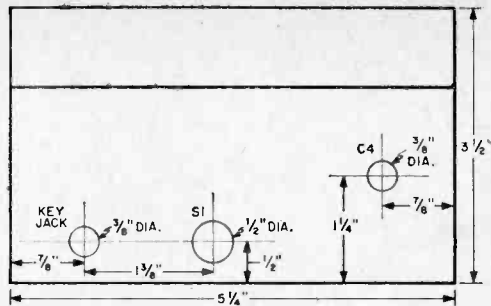

Fig. 2. The coil form should be drilled as shown at left. Front view of the file card box shows the cabinet holes.



The parts on the chassis include tube socket *A*, coil socket *B*, the crystal socket, and two  $\frac{3}{8}$ " rubber grommets (holes *C* and *D*). Begin the wiring *before* the chassis is installed in the cabinet. Use pins 1 and 8 of socket *B* for the coil.

Drill a  $\frac{3}{8}$ " hole in the lower rear of the cabinet on the side that the chassis will be placed. Put a rubber grommet in the hole and push your line cord through it. Knot the cord about 5" inside the cabinet to keep it from pulling through.

### installation

Mount the toggle switch in its hole. Slide the chassis into the cabinet and install two 6-32 screws from the back of the cabinet through the chassis. Place key jack *J1* through the holes in both the chassis (hole *E*) and the cabinet. Before tightening *J1*, make sure the lead coming from *RFC1* can be soldered to it.

The filter capacitor (*C5*) can be placed between the chassis and the cabinet. If *C5* has a metal mounting ring and lug, this must be removed to prevent it from shorting connections under the chassis.

The coil form is the base of an old octal-base tube. Some of these have a loose glass envelope that can be twisted off. If it is tight, place the tube in a bag and carefully break the glass envelope. Remove all the glass and glue from the inside of the base. Heat the pins and remove the wires in them. Then drill two small holes in the base to pass the wires from the coil to pins 1 and 8 in the base.

Use No. 20 gauge enamel wire for the coil (*L1*) and pass it through the hole nearest the pins. Then insert it into pin 8 and solder it. Looking at the pin end of the base, wind 30 turns in a counterclockwise direction. This should take you up to the second hole in the base.

Leave enough wire to reach through pin 1. Solder it as you did pin 8. To wind another coil for 40 meters, use 16 turns of wire.

### operation

To check out the rig, connect a 0-100 milliammeter across a plug which fits your key jack. Plug in the meter, plug in the line cord, and turn on the switch.

During warm-up, the meter pointer will move up and you can read the amplifier current on the meter. Tune *C4* in either direction until you notice the current suddenly drop. Tuning further in the same direction will cause the current to go up again. When the tube is oscillating, the current is very low (without a load on the transmitter); and when we tune past the range, the tube stops oscillating and the current rises.

The cabinet is connected to one side of the line, and therefore must never be connected to a separate ground such as a radiator. Serious shocks can result if both the cabinet and a separate ground are touched at the same time. To avoid this, we recommend an isolation transformer. And make sure to polarize the line plug—to insure that the chassis will be at line potential.

Depending on the type of antenna used, there are several ways in which the transmitter can be coupled to it. A good way is to wind two or three turns of wire around the tank coil, and connect one end to the chassis and the other to the antenna.

## IRON HAS SOLDER RESERVOIR

A small shallow hole drilled in one face of the tip of your soldering iron makes a handy "reservoir" to hold a drop or two of

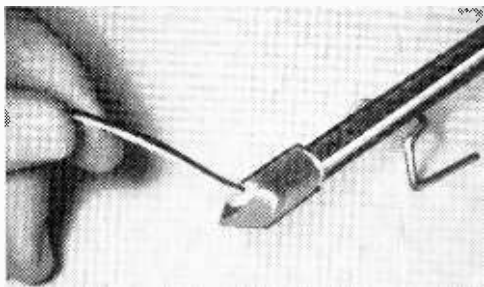

solder. When you work in hard-to-get-at places, the solder will flow from the reservoir onto the part being soldered. It's also handy for tinning tips of wires. —J.A.C.

## HUM CURE

If hum develops in a regenerative receiver or preamplifier which uses a transformer-powered selenium B+ supply, it can sometimes be cured simply by reversing the transformer's high-voltage secondary leads. The

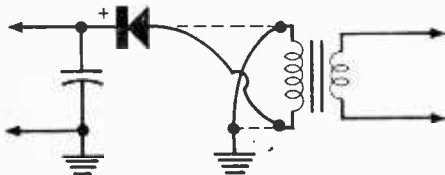

dashed lines in the schematic indicate the original wiring. The lead which previously went to the chassis should be connected to the rectifier terminal, and the lead which went to the rectifier connected to chassis. —F.H.T.

## PHONES DETECT SPEAKER TROUBLE

When you suspect that a defective speaker is the source of distortion emerging from your hi-fi system, radio or TV, here's a simple method that can be used to verify or eliminate your suspicions. Disconnect the primary of the speaker's output transformer, connect a sensitive pair of headphones across the primary and, while wearing the phones, carefully press your fingers on the speaker cone and move it in and out. A loud rasping sound indicates that the voice-coil is rubbing the pole piece. If no rasping is heard, check elsewhere in the system for the trouble. Perhaps there's a defective tube or capacitor.—J.A.C.

send for this

**FREE**

**EICO  
Electronics  
Catalog**



you save 50% on Top-Quality  
**Test Instruments**  
**Hi-Fi • Ham Gear**

**KITS AND WIRED**

for professional and home use

### TEST INSTRUMENTS

battery eliminators  
battery testers  
bridges  
decade boxes  
electronic switch  
flyback tester  
oscilloscopes  
probes  
signal and  
sweep generators  
tube testers  
transistor tester  
vacuum tube  
voltmeters  
volt-ohm-  
milliammeters

### HI-FI

stereo and monaural  
tuners  
preamplifiers  
power amplifiers  
integrated amplifiers  
speaker systems

### HAM GEAR

cw transmitter  
modulator-driver  
grid dip meter

OVER 1½ MILLION  
EICO instruments in  
use throughout  
the world.

LIFETIME service and calibration guarantee.  
IN STOCK at your neighborhood EICO dealer.  
Send now for FREE catalog EH-59.

**EICO**

33-00 N. Blvd., L. I. C. 1, N. Y.

...praised by the experts  
as **BEST BUYS IN ELECTRONICS**

© 1959 ELECTRONIC INSTR. CO., INC.



Every \$1 sends a 22 lb. Food  
Crusade package to the  
world's hungry thru CARE,  
New York 16

# NEW! ULTRA HIGH QUALITY TRANSISTOR TRANSFORMERETTES\*

## MU-METAL SHIELDED Miniature Transformers

Ruggedized, one-piece, gapless core construction employed. Thirteen types of Input, Inter-stage, driver and output transformers for use in 90 different impedance matching circuits. Available in rectangular, cylindrical, octal and noval plug-in cases. Epoxy impregnated for moisture protection. Hermetically sealed units meet MIL-T-27A standards. Manufactured with modern core materials in accordance with newest engineering techniques. Rectangular size: 13/16" long, 17/32" wide, 17/32" high. Weight less than 1/2 ounce. Used in all miniaturized, transistorized equipment.



3/4 ACTUAL SIZE

### Type R-6 Rectangular Case Transformerettes\*

P-9	Driver	PRI.	25,000 CT	SEC.	600 CT	\$3.95
P-2	Driver		20,000 CT		1,000 CT	2.95
P-10	Driver		15,000 CT		600 CT	3.50
P-2	Output		15,000 CT		600 CT	2.95
P-2	Output		10,000 CT		500 CT	2.95
P-4	Driver		5,000 CT		3,000	3.95
P-10	Output		5,000 CT		200 CT	3.50
P-3	Driver		2,000		1,200 CT	3.50
P-3	Driver		1,200 CT		2,000	3.50
P-4	Driver		1,200		2,000 CT	3.95
P-4	Output		1,000 CT		600	3.95
P-7	Output		1,000 CT		50	3.50
P-5	Output		1,000 CT		16	3.50
P-9	Input		600 CT		25,000 CT	3.95
P-6	Output		600 CT		16	3.50
P-8	Output		600 CT		4	3.50
P-8	Output		500 CT		3.2	3.50
P-6	Output		300 CT		8	3.50
P-10	Output		200 CT		5,000 CT	3.50
P-5	Output		200 CT		3.2	3.50
P-7	Output		100		2,000 CT	3.50
P-10	Input		50 CT		1,250 CT	3.50
P-8	Input		3.2		500 CT	3.50

MINIMUM ORDER \$10.00. For immediate, postpaid delivery, check boxes and mail off with your remittance. For additional models of Transformerettes\* write to Dept. E.H.:

**AMPLIFIER CORP. of AMERICA 398 Broadway, New York 13, N. Y.**

## ADVERTISERS INDEX

ADVERTISER	PAGE NO.
Advertising Council, The	107
Allied Radio Corp.	47
American Basic Science Club, Inc.	5
Amplifier Corp. of America	162
Burstein-Applebee Co.	125
Capitol Radio Engineering Institute	7
CARE	161
EICO	161
Electronic Division Classified	153
Filnor Products Inc.	39
Gyro Electronics Co.	125
Hi-Fi Guide & Yearbook	18
National Radio Institute	Fourth Cover
National Schools	40
Philadelphia Wireless Technical Institute	109
Popular Electronics Subscription	66
Popular Photography 35-MM Annual	145
Prentice-Hall, Inc.	60
Progressive "Edu-Kits" Inc.	99
RCA Institute, Inc.	Third Cover
Schober Organ Corp., The	107
Sports Cars Illustrated Directory	136
Sprayberry Academy of Radio-Television	Second Cover
Video Electric Company	8
Zalytron Tube Corporation	109
Ziff-Davis Annuals	130

## emergency solder on cord

There's no danger of not having solder always on hand when it's needed if, when you buy a new spool, you cut off a length

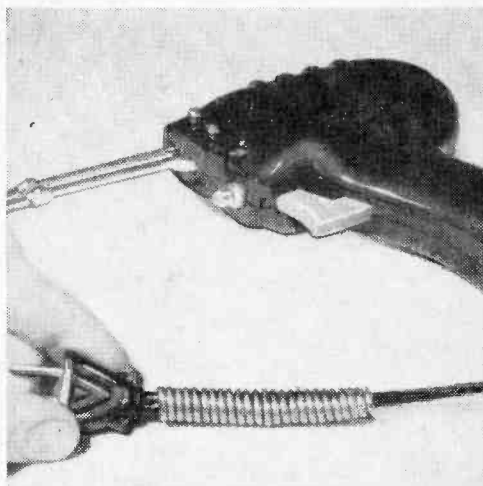

and spiral it around the power cord of your soldering gun or iron. Wrap it tightly around the cord near the plug as shown and it will also protect the cord at this natural point of wear. —J. A. C.

## untangled soldering iron cord

Are you tired of having a tangled soldering iron cord in your tool box? Cut the

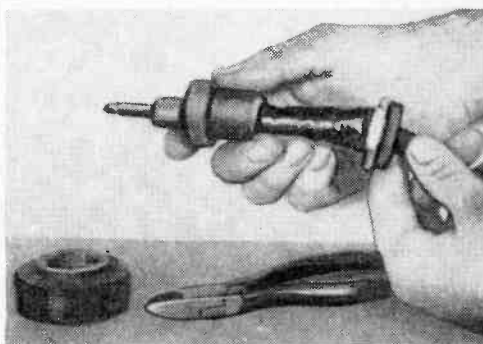

existing cord an inch from the handle and solder a male receptacle of the type used on TV sets to the short leads. Tape the connections securely. Now you can use any TV cheater cord to heat your iron, which can be neatly and easily attached, detached and stored. —P. B.

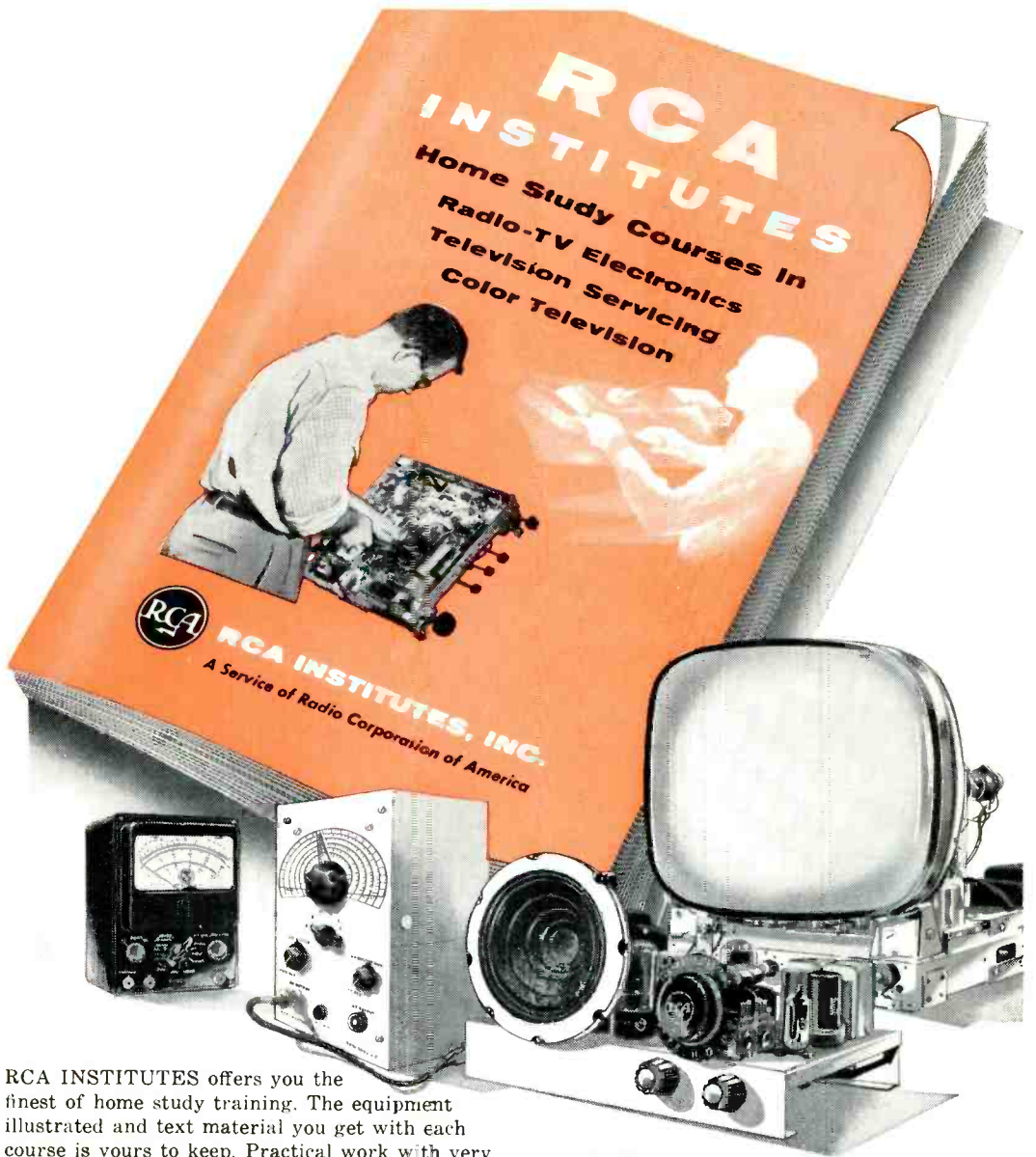

RCA INSTITUTES offers you the finest of home study training. The equipment illustrated and text material you get with each course is yours to keep. Practical work with very first lesson. Courses for the beginner and the advanced student. Pay-as-you-learn. You need pay for only one study group at a time.

**Send for this  
FREE Book Now** 

**RESIDENT SCHOOL** courses in New York City offer comprehensive training in Television and Electronics. Day and evening classes start four times each year.

Detailed information on request.

**RCA INSTITUTES, Inc.** Home Study Dept. EE-59

A Service of Radio Corporation of America

350 West Fourth Street, New York 14, N. Y.

Without obligation, send me FREE 52 page CATALOG on Home Study Courses in Radio, Television and Color TV. No salesman will call.

Name  please print

Address

City  Zone  State

Korean Vets! Enter discharge date

**CANADIANS** - Take advantage of these same RCA courses at no additional cost. No postage, no customs, no delay. Send coupon to: RCA Victor Company, Ltd., 5001 Cote de Liesse Rd., Montreal 9, Quebec

To save time, paste coupon on postcard.

# Learn Radio-Television

## Servicing or Communications by Practicing at Home in Spare Time

N. R. I. SENDS kits with which you practice building circuits common to Radio and TV sets. You LEARN-BY-DOING to locate Radio-TV troubles. As part of N. R. I. Servicing Course, you build Vacuum Tube Voltmeter and AC-DC receiver. Use VTVM to conduct experiments, earn extra money fixing sets in spare time.

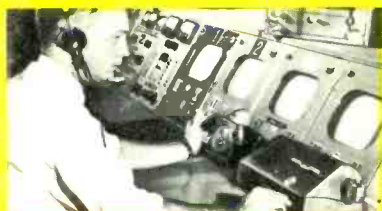
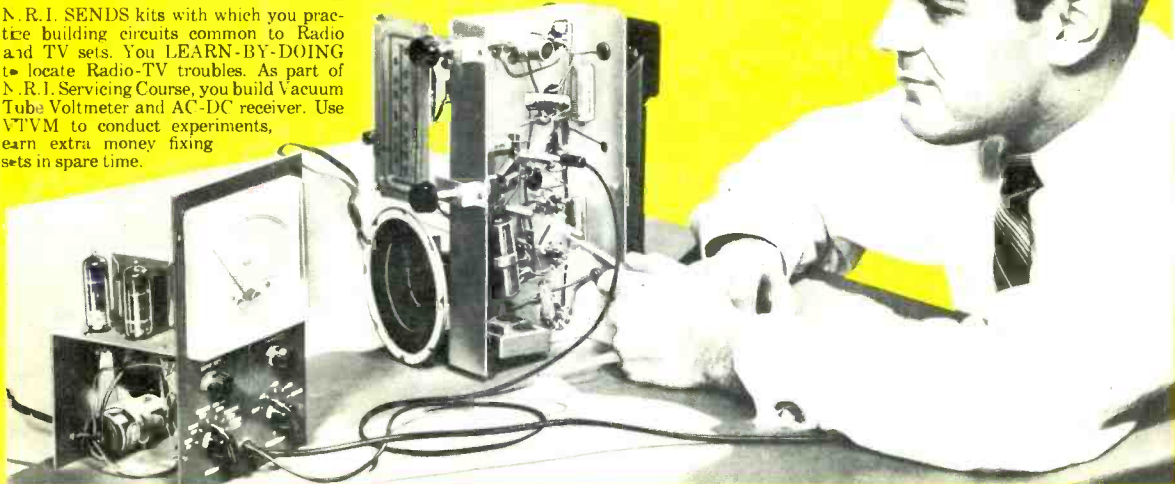

**RADIO-TV BROADCASTING** (see above) offers important positions as Operators and Technicians. **RADIO-TV SERVICING Technicians** (see below) needed in every community. Their services are respected, their skill appreciated.



## Fast Growing Field Offers You Good Pay, Success, Bright Future



**J. E. SMITH**  
founder

Bigger than ever and still growing fast. That's why Radio-TV has special appeal to ambitious men not satisfied with their job and earnings. More than 4,000 Radio and TV stations. More than 150 million home and auto Radios, 40 million TV sets. Color TV promises added opportunities. For the trained man, there are good jobs, bright futures in Radio-TV Servicing or Broadcasting. Training PLUS opportunity is the ideal combination for success. So plan now to get into Radio-TV. The technical man is looked up to. He does important work, gets good pay for it. Radio-Television offers that kind of work. NRI can supply training quickly, without expense of going away to school. Keep your job while training. You learn at home in your spare time. NRI is the OLDEST and LARGEST home study Radio-TV school. Its methods have proved successful for more than 40 years.

### Added Income Soon - \$10, \$15 a Week in Spare Time

Soon after enrolling, many NRI students start to earn \$10, \$15 a week in spare time fixing sets. Some pay for their training and enjoy extra luxuries this way. Some make enough to start their own Radio-TV shops. NRI training is practical—gets quick results. Easy to understand, well illustrated lessons teach you basic principles. And you LEARN-BY-DOING by practicing with kits of equipment which "bring to life" things you study.

### Find Out What NRI Offers

NRI has trained thousands for successful careers in Radio-TV. Study fast or slow—as you like. Diploma when you graduate. Mail coupon now. Paste it on a postcard or mail in envelope. ACTUAL LESSON FREE. Also 64 page catalog that shows opportunities, shows equipment you get. Cost of NRI courses low. Easy terms. **NATIONAL RADIO INSTITUTE, Dept. 9AE2, Washington 16, D. C.**

### N.R.I. TRAINED THESE MEN FOR SUCCESS



"I was repairing Radios by 10th lesson. Now have good TV job." **M. R. LINDEMUTH, Fort Wayne, Ind.**



"Doing spare time repairs on Radio and TV. Soon servicing full time." **CLYDE HIGGINS, Waltham, Mass.**

"I had a successful Radio repair shop. Now I'm Engineer for WHPF." **V. W. WORKMAN, High Point, N. C.**



"There are a number of NRI graduates here. I can thank NRI for this job." **JACK WAGNER, Lexington, N. C.**



### VETERANS Approved Under G. I. Bills

### SEND FOR BOTH FREE

**National Radio Institute**  
Dept. 9AE2, Washington 16, D. C.

Mail me Sample Lesson and 64-Page Catalog FREE. (No salesman will call. Please write plainly.)

Name \_\_\_\_\_ Age \_\_\_\_\_

Address \_\_\_\_\_

City \_\_\_\_\_ Zone \_\_\_\_\_ State \_\_\_\_\_

Accredited Member National Home Study Council

