

FALL EDITION \$1.25

1965

POPULAR  
ELECTRONICS

# ELECTRONIC EXPERIMENTER'S

# HANDBOOK

PROJECTS  
GALORE

SCIENCE FAIR

AUDIO

HOUSEHOLD

AUTOMOTIVE

TEST EQUIPMENT

HI-FI

FISHING

HAM RADIO

CB AND TV

PLUS:  
SPECIAL  
SECTION

"THE  
FABULOUS  
DIODES"

NEW  
MORE  
POWERFUL  
TESLA COIL  
(page 91)



# BETTER THAN EVER!

Mail the Card Today for Your FREE Catalog

No Money Down • Easy Pay Terms

**1966**  
CATALOG NO.  
**660**

Live Better Electronically With

## LAFAYETTE RADIO ELECTRONICS

Over 500 Pages

# FREE!



- TV Tubes and Parts
- Electronic Parts
- Test Equipment
- Citizens Band
- Tools
- Ham Gear
- Stereo Hi-Fi
- Tape Recorders
- Walkie-Talkies
- Auto Accessories

Featuring Everything in Electronics for

• HOME • INDUSTRY • LABORATORY

from the

**“World’s Hi-Fi & Electronics Center”**

LAFAYETTE'S MAIL ORDER &  
LONG ISLAND  
SALES CENTER



111 Jericho Turnpike  
Syosset, Long Island, New York

### OTHER LOCATIONS

NEW YORK—45th ST.  
71 West 45 St.  
BROOKLYN, NEW YORK  
2265 Bedford Avenue  
NEW YORK, NEW YORK  
17 Union Square W.  
(cor. 15 St.)  
JAMAICA, NEW YORK  
165-08 Liberty Avenue  
SCARSDALE, NEW YORK  
691 Central Avenue  
BRONX, NEW YORK  
542 E. Fordham Road

MT. RAINIER/  
HYATTSVILLE, MD.  
3191 Queens Chapel Road  
NEWARK, NEW JERSEY  
24 Central Avenue  
PLAINFIELD, NEW JERSEY  
139 West 2 Street  
PARAMUS, NEW JERSEY  
182 Route 17  
BOSTON, MASS.  
584 Commonwealth Avenue  
NATICK, MASS.  
1400 Worcester Street

LAFAYETTE Radio ELECTRONICS  
Dept. EH-J-3-5, P.O. Box 10  
Syosset, L.I., N.Y. 11791

Send  
FREE Lafayette  
Catalog

Name \_\_\_\_\_

Address \_\_\_\_\_

City \_\_\_\_\_ State \_\_\_\_\_

Zip \_\_\_\_\_

(Please Give Your Zip Code No.)

CIRCLE NO. 12 ON READER SERVICE CARD

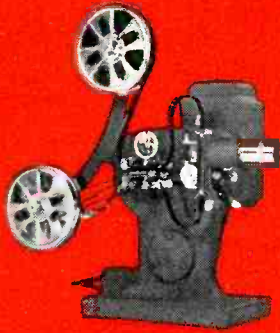

Prepare  
At HOME or  
in our CHICAGO  
or TORONTO  
Laboratories

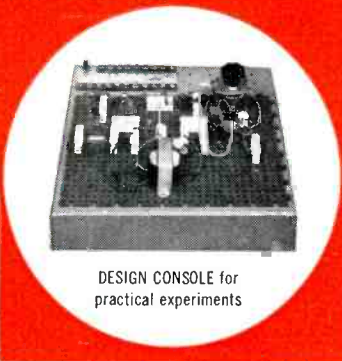
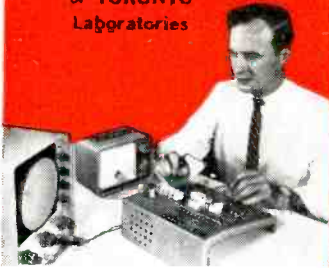

"Learn-by-seeing"  
training MOVIES

Build & Keep a  
5" OSCILLOSCOPE

DESIGN CONSOLE for  
practical experiments

Build & Keep a  
TRANSISTORIZED METER

DeVRY TECH SUPPLIES ALL THIS AND MORE TO PREPARE YOU TO

# Become an Electronics Technician

Would a career as an **ELECTRONICS TECHNICIAN** interest you? Perhaps you would like the Computer field . . . Instrumentation . . . Radio and Television . . . Automation or Control System work . . . a Space and Missile job. If so, **READ ON.**

Using DeVry's highly effective "programmed" texts - **AND ALL OF THE PRACTICAL EQUIPMENT PICTURED ABOVE**, many men, *probably much like you*, are now preparing at home in their spare time for wonderfully interesting, good-paying careers in every major branch of the vast, growing electronics industry. Others are

learning day or evening in our well-equipped Chicago or Toronto Laboratories.

You don't have to be a "super type" to get started toward a career in electronics! Far more important to success are ambition, average education and intelligence, interest in mechanical or electrical things.

**SOUND INTERESTING?** Then see for yourself how **YOU** may get ready to join the many DeVry graduates now enjoying good jobs, fine salaries and real progress in one of today's outstanding fields—**ELECTRONICS**. Mail the coupon today for no-obligation details.

## FREE!

Send for these two information-packed booklets **NOW!**

### EMPLOYMENT SERVICE

DeVry's highly effective Employment Service is available to all graduates at no additional cost.



**DeVRY TECHNICAL INSTITUTE**  
4141 Belmont Ave., Chicago 41, Ill., Dept. EEH-2-V

Please give me two free booklets, "Pocket Guide to Real Earnings" and "Electronics in Space Travel"; also include details on how to prepare for a career in Electronics. I am interested in the following opportunity fields (check one or more):

- |  |   |
|--|---|
| <input type="checkbox"/> Space & Missile Electronics | <input type="checkbox"/> Communications         |
| <input type="checkbox"/> Television and Radio        | <input type="checkbox"/> Computers              |
| <input type="checkbox"/> Microwaves                  | <input type="checkbox"/> Broadcasting           |
| <input type="checkbox"/> Radar                       | <input type="checkbox"/> Industrial Electronics |
| <input type="checkbox"/> Automation Electronics      | <input type="checkbox"/> Electronic Control     |

Name \_\_\_\_\_ Age \_\_\_\_\_

Address \_\_\_\_\_ Apt. \_\_\_\_\_

City \_\_\_\_\_ Zone \_\_\_\_\_ State \_\_\_\_\_

Check here if you are under 16 years of age.

Canadian residents: Write DeVry Tech of Canada, Ltd  
2094 970 Lawrence Avenue West, Toronto 19, Ontario

## DeVry Technical Institute

Chicago • Toronto  
4141 Belmont Avenue  
Chicago, Illinois 60641



CIRCLE NO. 33 ON READER SERVICE CARD



# NEW FROM INTERNATIONAL

## VHF/UHF UNITIZED TRANSMITTERS 50 mc - 420 mc

International's new unitized VHF/UHF transmitters make it extremely easy to get on the air in the 50-420 mc range with a solid signal. Start with the basic 50 or 70 mc driver. For higher frequencies add a multiplier-amplifier. All units are completely wired. Plug-in cables are used to interconnect the driver and amplifier.

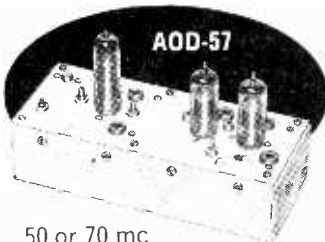

**AOD-57**  
50 or 70 mc  
**DRIVER/TRANSMITTER**  
The AOD-57 completely wired with one 6360 tube, two 12BY7 tubes and crystal (specify frequency). Heater power: 6.3 volts @ 1.2 amps. Plate power: 250 vdc @ 50 ma. AOD-57 complete.....\$69.50

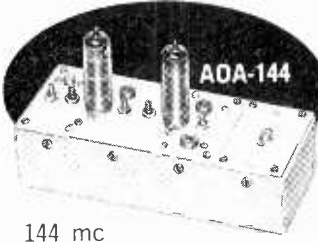

**AOA-144**  
144 mc  
**MULTIPLIER/AMPLIFIER**  
The AOA-144 uses two 6360 tubes providing 6 to 10 watts output. Requires AOD-57 for driver. Heater power: 6.3 volts @ 1.64 amps. Plate power: 250 vdc @ 180 ma. AOA-144 complete.....\$39.50

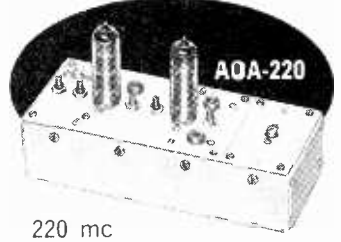

**AOA-220**  
220 mc  
**MULTIPLIER/AMPLIFIER**  
The AOA-220 uses two 6360 tubes providing 6 to 8 watts output on 220 mc. Requires AOD-57 for driver. Heater power: 6.3 volts @ 1.64 amps. Plate: 250 vdc @ 150 ma. AOA-220 complete.....\$39.50

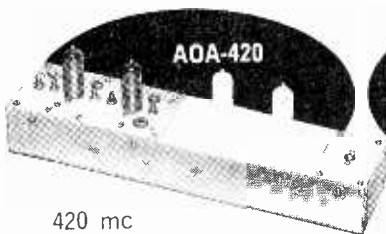

**AOA-420**  
420 mc  
**MULTIPLIER/AMPLIFIER**  
The AOA-420 uses two 6939 tubes providing 4 to 8 watts output on 420 mc. Requires AOA-57 plus AOA-144 for drive. Heater: 6.3 volts @ 1.2 amps. Plate: 220 vdc @ 130 ma. AOA-420 complete.....\$69.50

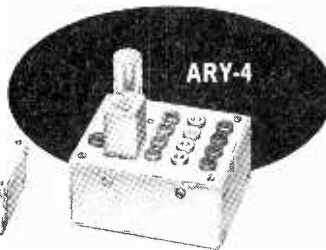

**ARY-4**  
**RELAY BOX**  
Four circuit double throw. Includes coil rectifier for 6.3 vac operation. ARY-4 Relay Box complete .....\$12.50

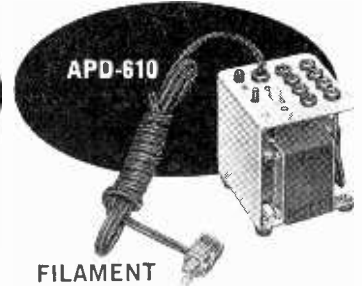

**APD-610**  
**FILAMENT SUPPLY**  
The APD-610 provides 6.3 vac @ 10 amperes. APD-610 complete.....\$9.50



**AMD-10**  
**MODULATOR**  
The AMD-10 is designed as a companion unit to the AOA series of transmitters. Uses 6AN8 speech amplifier and driver, 1635 modulator. Output: 10 watts. Input: crystal mic. (High Imped.) Requires 300 vdc 20 ma, no signal, 70 ma peak: 6.3 vac @ 1.05 amps. AMD-10 complete .....\$24.50

### COMPLETE TRANSMITTER

6 METERS	50 mc	AOD-57
2 METERS	144 mc	AOD-57 PLUS AOA-144
	220 mc	AOD-57 PLUS AOA-220
	420 mc	AOD-57 PLUS AOA-144 PLUS AOA-420



**CRYSTAL MFG. CO., INC.**

1810 N. LEE • OKLA. CITY OKLA. 73102

CIRCLE NO. 13 ON READER SERVICE CARD

Order Direct  
from International

FALL EDITION  
1965  
POPULAR ELECTRONICS  
**ELECTRONIC**  
**EXPERIMENTER'S**  
HANDBOOK

**PHILLIP T. HEFFERNAN**

Publisher

**OLIVER P. FERRELL**

Editor

**ROBERT CORNELL**

Managing Editor

**JOHN D. DRUMMOND**

Technical Editor

**WILLIAM GALBREATH**

Art Editor

**MARGARET MAGNA**

Associate Editor

**ANDRE DUZANT**

Technical Illustrator

**NINA CHIRKO**

Editorial Assistant

**PATTI MORGAN**

Editorial Assistant

**LAWRENCE SPORN**

Advertising Sales Manager

**ARDYS C. MORAN**

Advertising Service Manager

**ZIFF-DAVIS PUBLISHING COMPANY**

Editorial and Executive Offices (212 ORegon 9-7200)

One Park Avenue, New York, New York 10016

William B. Ziff, Chairman of the Board (1946-1953)

William Ziff, President

W. Bradford Briggs, Executive Vice President  
Hershel B. Sorbin, Vice President and General Manager

Philip Sine, Financial Vice President

Walter S. Mills, Jr., Vice President, Circulation

Stanley R. Greenfield, Vice President, Marketing

Phillip T. Heffernan, Vice President

Frank Pamerantz, Vice President, Creative Services

Arthur W. Butzow, Vice President, Production

New York Office (212 ORegon 9-7200)

One Park Avenue, New York, New York 10016

Eastern Advertising Manager, RICHARD J. HALPERN

Midwestern Office (312-726-0892)

307 North Michigan Avenue, Chicago, Illinois 60601

Midwestern Advertising Manager, JAMES WEAKLEY

Western Office (213 CRestview 4-0265)

9025 Wilshire Boulevard, Beverly Hills, California 90211

Western Advertising Manager, BUD DEAN

Circulation Office

One Park Avenue

New York, New York 10016



1965 ELECTRONIC EXPERIMENTER'S HANDBOOK, Fall Edition, published by the Ziff-Davis Publishing Company, One Park Avenue, New York, New York 10016. Also publishers of Popular Electronics, Electronics World, HiFi/Stereo Review, Communications Handbook, Tape Recorder Annual, Stereo/Hi-Fi Directory, Electronics Installation and Servicing Handbook. Copyright © 1965 by Ziff-Davis Publishing Company. All rights reserved.

*The Fall Edition of the ELECTRONIC EXPERIMENTER'S HANDBOOK is the tenth in a series that began in 1957. Due to the increasing popularity of electronics project building and experimentation, two editions of the EXPERIMENTER'S HANDBOOK are now being printed every year. In February we publish a Spring Edition, in October a Fall Edition. As in the preceding nine editions, this one contains construction projects and feature articles especially selected by the Editors of POPULAR ELECTRONICS.*

*We are particularly pleased with the projects in this Fall Edition and direct our readers' attention to the new chapter category of Science Fair Projects. It is anticipated that this chapter will be enlarged in future issues.*

*In the center of this Edition you will find a special 16-page article by Louis Garner on solid-state technology as it particularly applies to diodes. This is a state-of-the-art report and is comparable to feature articles of a similar nature that appear from time to time in POPULAR ELECTRONICS. Also in this Edition are several projects that first saw the light of day in our next-door-neighbor publication, ELECTRONICS WORLD. These articles have been completely revised for use in the EXPERIMENTER'S HANDBOOK.*

*If you have suggestions for future content, please don't hesitate to write to us.*

**THE EDITORS**

# Hy-Gain COMMUNICATIONS ANTENNAS

... where all BIG signals come from!

## High Frequency Antennas For 10 Thru 80 Meters

Anywhere in the world you want to talk, there's a Hy-Gain antenna designed to provide you with maximum performance from your Amateur Radio equipment. Automatic Band Switching Verticals—Duo-Beams—Tri-Bander Beams—Multi-Band Trap Doublets—Famous "Topper" Mobile Whips PLUS many, many more ranging from standard ground planes to the incomparable DX "Long John" optimum spaced beams for the Ham who wants the whole world at his fingertips. All pictured and described in Hy-Gain's FREE 16-page Catalog No. 200

## VHF Antennas For 6, 2, 1¼ and ¾ Meters

For maximum performance across town or using moon bounce, Hy-Gain VHF antennas will deliver the strongest signals for you. Gain Ground Planes—Gain Stacked Jay-Poles—Mono-Band Beams—Base Station and Mobile Halos—Duo-Band Beams—Duo-Band Mobile Whips—and, a host of others. All pictured and completely described in Hy-Gain's FREE 16-page Catalog No. 100.

## Base Station and Mobile Antennas for CITIZENS BAND

**Fabulous New Directional Duo-Beams**— Deliver up to 120 watts "Talk Power"—Effectively block off signals from the side and back—Rotate to concentrate maximum power with pinpoint accuracy 360° on the compass—Guaranteed to out-perform any other base station antenna for Citizens Band. Three models to choose from...all pictured and fully described with important comparison data in Hy-Gain's FREE Catalog No. 13.

**World Famous CLR2**— Delivers all-directional "Talk-Power" of 12.55 watts—Keeps you constantly alert to signals from all directions surrounding your station—Has 5/8 wavelength radiator acknowledged as essential for maximum efficiency—Guaranteed to out-perform any other all-directional antenna for Citizens Band. Completely described with important comparison data in Hy-Gain's FREE Catalog No. 16.

**Pace Setting Mobile "Toppers"**—Roof Mounts, Trunk Mounts, Fender Mounts, Cowl Mounts, Marine Mounts, AM-CB combinations. All models guaranteed to out-perform any other mobile antenna of comparable length and mount. Each model pictured and fully described with important comparison data in Hy-Gain's FREE Catalog No. 15.

## Short Wave Listener Antennas

Precision engineered and tuned antennas designed to provide maximum short wave listening enjoyment on all of the popular bands from 1.8 thru 30 mc. Two popular models to choose from for world-wide performance...one for outdoor or attic installation...one for window sill or portable applications where space is a factor. Both models completely described in Hy-Gain's FREE Catalog No. 20.



## Hy-Gain ELECTRONICS CORPORATION

8300 N.E. Highway 6 — Lincoln, Nebraska 68501

Rush the following literature to me:

- HF Catalog No. 200     "Topper" Catalog No. 15     CLR2 Catalog No. 16  
 Duo-Beam Catalog No. 13     VHF Catalog No. 100     SWL Catalog No. 20

NAME \_\_\_\_\_

ADDRESS \_\_\_\_\_

CITY \_\_\_\_\_

STATE \_\_\_\_\_

ZIP \_\_\_\_\_

## SEND COUPON TODAY

Indicate the material you wish to receive—or, contact your Hy-Gain distributor!

The World's Largest  
Manufacturer of  
Communications Antennas

CIRCLE NO. 11 ON READER SERVICE CARD

FALL EDITION  
 1965  
 POPULAR ELECTRONICS  
**ELECTRONIC  
 EXPERIMENTER'S  
 HANDBOOK**  
**CONTENTS**

**1  
 USEFUL  
 HOUSEHOLD  
 PROJECTS**

7  
*"CQ Fish"—Panic Alarm—Pocketable Metronome  
 —For Greater Safety Flash Those Lights—Elec-  
 tronic Candles Dance and Glow—Add D.C. Resto-  
 ration to TV—Multi-Trol—High Wattage Reducer  
 —Nonsense Box*

**2  
 AUDIO  
 STEREO  
 HI-FI  
 PROJECTS**

39  
*For Better Sound Build the Bi-Coupler—Stereo  
 S'Lector—Vibrato Simulator—Hi-Fi Volume Com-  
 pressor Expander—Hi-Fi Interlock—Shotgun  
 Sound Snooper*

**3  
 THE  
 FABULOUS  
 DIODES**

67  
*The Fabulous Diodes: Zener Diodes—Diode  
 Switches—Photodiodes—Tunnel Diodes—Capacitor  
 Diodes—Power Diodes—Surge Suppressors—Ther-  
 moelectric Diodes—Special Diodes*

**4  
 SCIENCE  
 FAIR  
 PROJECTS**

87  
*60-Cycle Repulsion Coil—Resonance Engine—Big  
 TC—Li'l TC*

**5  
 COMMUNI-  
 CATIONS  
 SWL  
 CB  
 HAM**

103  
*Transistorized 6-Meter Converter—Adjustable  
 Speech Filter—Companion 6-Meter Transmitter—  
 Soup Up That AM Broadcast Receiver—6-Meter  
 7 and 2 Preamp*

**6  
 TEST  
 EQUIPMENT  
 PROJECTS**

123  
*Hybrid Circuit for Transistor Power—SCR Tester  
 —Field-Effect Transistor Voltmeter—Multiple  
 Meter Test Set—Multi-Output Zener Voltage Reg-  
 ulator—Best of Tips and Techniques*

# NEW! 3 RCA EXPERIMENTER'S KITS

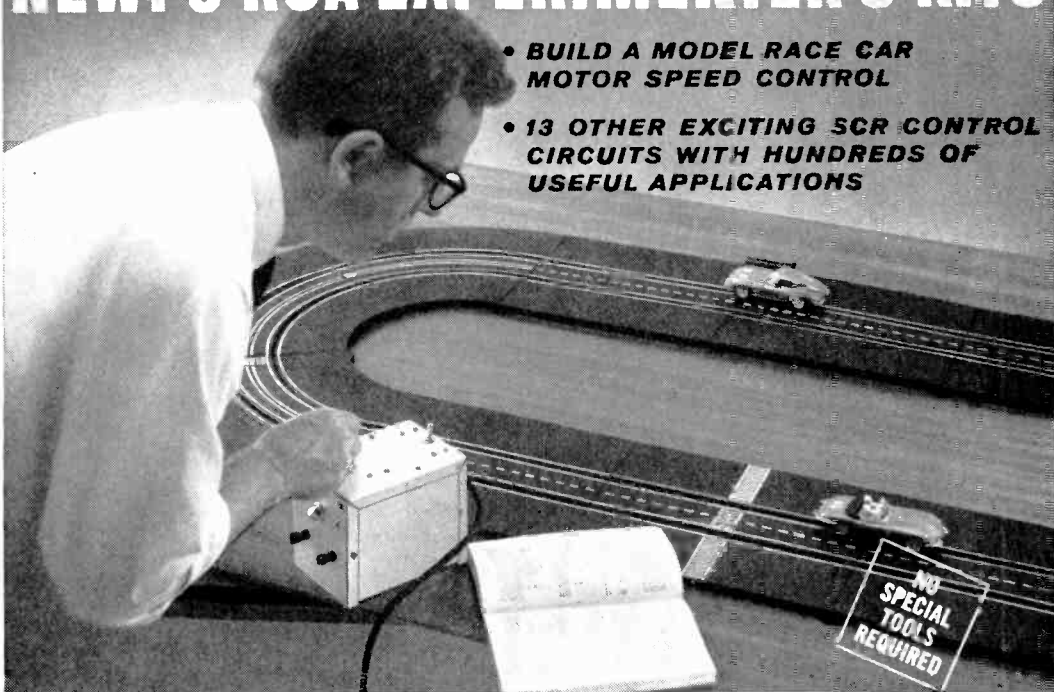

- **BUILD A MODEL RACE CAR MOTOR SPEED CONTROL**
- **13 OTHER EXCITING SCR CONTROL CIRCUITS WITH HUNDREDS OF USEFUL APPLICATIONS**

Here's what you've been waiting for...now, you can build your own silicon controlled-rectifier control circuits. Start with RCA's Basic Experimenter's Kit (KD2105). With it, you can build a model race car speed control, a universal motor speed control, or eight other interesting circuits. Add-on Light Sensor and Heat Sensor Kits (KD2106 and KD2110) enable you to build 4 more electronic control circuits for hundreds of useful applications around the house, hobby shop, and garage.

The 80-page, illustrated RCA Experimenter's Manual (KM-70) will familiarize you with the theory and operation of solid-state components in the kits. At the same time, it will give you complete detailed information on all 14 circuits including schematic diagrams, circuit descriptions, and construction details, as well as photographs of the circuits as easy-to-follow assembly guides.

*Here is what you can make...*

1. Electronic Timer. 2. Electronic Time Delay Switch. 3. Electronic Flasher. 4. Battery Charger (12 volts). 5. Battery Charger (6 volts). 6. Model Race Car and Railroad Speed Control. 7. Light-operated Switch (Turn-on). 8. Light-operated Switch (Turn-off). 9. Electronic Heat Control (Turn-on). 10. Electronic Heat Control (Turn-off). 11. Over-load Switch. 12. Electronic Synchronous Switch. 13. Universal Motor Speed Control. 14. Lamp Dimmer.

*Here is what You Need...*

- RCA Basic Experimenter's Kit (KD2105) One Silicon Controlled-Rectifier; Two Transistors; Five Rectifiers.
- RCA Experimenter's Manual (KM-70) 80 Illustrated Pages; 14 Circuits and How to Build Them.
- RCA Add-On Light Sensor Kit (KD2106) One Photocell for light-operated switches.
- RCA Add-on Heat Sensor Kit (KD2110) Three Thermistors, special solder for heat-control circuits.
- Plus readily available standard components.

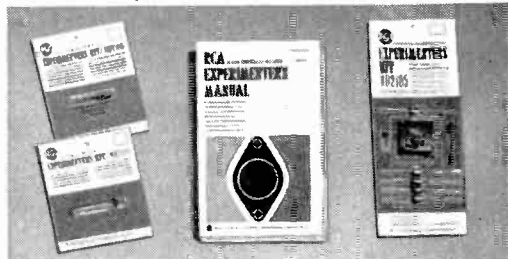

If you want to build one circuit or all 14, check with your RCA Distributor where kits and RCA Experimenter's Manual are on display. He'll be glad to help you select the kit or kits for the solid-state circuit you have in mind. Do it today!

Available from your RCA semiconductor distributor  
RCA ELECTRONIC COMPONENTS AND DEVICES, HARRISON, N. J.



The Most Trusted Name in Electronics

CIRCLE NO. 23 ON READER SERVICE CARD



# CHAPTER

1

## USEFUL HOUSEHOLD PROJECTS

Construction projects to be used around the house are generally of great interest to readers of the *ELECTRONIC EXPERIMENTER'S HANDBOOK*, since such projects can be displayed and operated by the "non-electronically minded" members of the family. They "prove" that the hobbyist-experimenter is not just fooling around and wasting his time. The projects in this chapter have been selected to appeal to the entire family—even though the first project ("CQ Fish" on page 8) is for the OM himself.

The "Panic Alarm" (page 11) and "Nonsense Box" (page 36) are wonderful electronic "gags." Both of these projects appear in the stores at Christmas time—selling for 5 to 10 times the cost of building one with brand-new parts. The metronome (page 14), safety flasher (page 15), and "Multi-trol" (page 28) are all handy household items. And, speaking of Christmas, take a look at the electronic device to make your tree lights twinkle (page 17). The d.c. restorer project (page 22) is one you should consider if you have a TV set that could use some improvement in black and white picture reproduction.

8	"CQ FISH" .....	Bill Billick
11	PANIC ALARM .....	Roy E. Pafenberg, W4WKM
14	POCKETABLE METRONOME .....	Sal Stella
15	FOR GREATER SAFETY FLASH THOSE LIGHTS.....	Louis F. Cortina
17	ELECTRONIC CANDLES DANCE AND GLOW.....	Jeff H. Taylor
22	ADD D.C. RESTORATION TO TV .....	Charles E. Cohn
28	MULTI-TROL .....	Ryder Wilson
31	HIGH WATTAGE REDUCER .....	Frank A. Parker
36	NONSENSE BOX .....	Alan L. Danzis

# "CQ FISH"

**Fish can't resist this CQ from a weight belt. You have your pick of the pack when this electronic lure broadcasts its call of the deep . . .**

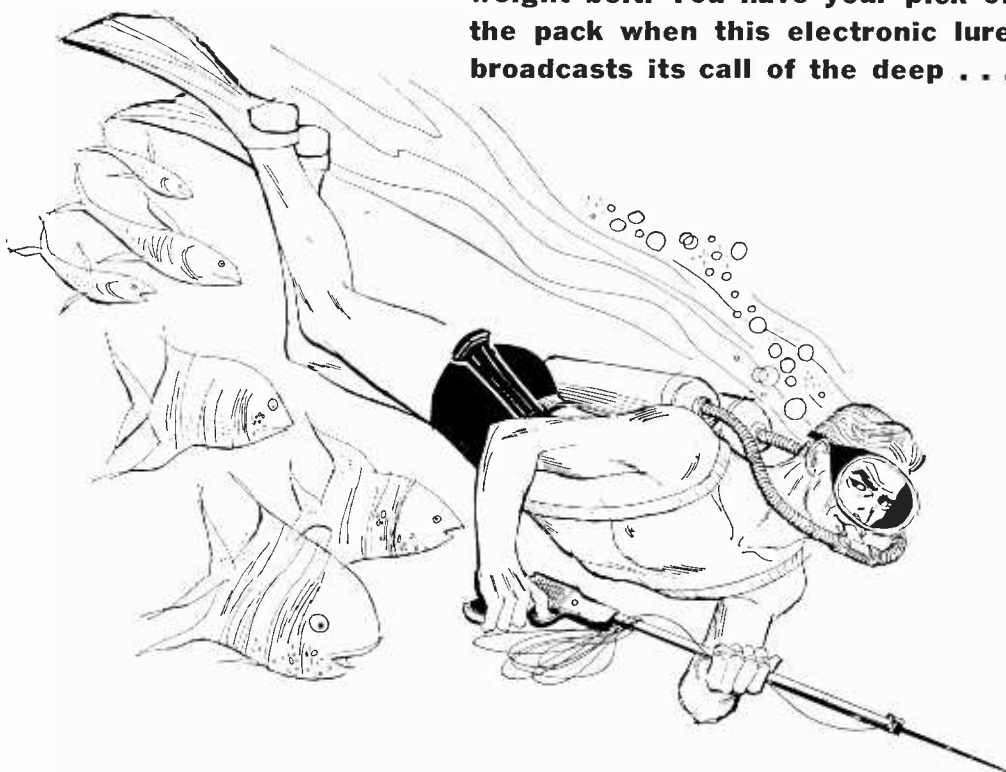

**By BILL BILLICK**

**E**LECTRONIC FISH LURES have been used for years by "stick" fishermen. Such lures depend on the low intelligence level of the fish, and have actually worked well. While it is dubious that anybody ever psychoanalyzed a fish, the great attraction would seem to be that the noise emanating from the lure sounds like food. Another theory is that all fish do not dine in the same fashion, and what might sound like food to one would just arouse the curiosity of another. In either case, the fish is lured to his ultimate destruction!

**Double-Duty Lure.** The fish lure described here can be employed with a fishing rod or by a skin diver. The housing of a pressure-proof skin-diving flashlight permits its use at depths up to 200 feet. To use the lure with a rod, you lower it into the water after turning it on and replacing the end-cap. A skin diver should turn the unit on before entering the water. The flashlight housing can be attached conveniently to a spear gun, weight belt, or a line. The transistor circuit is a simple Hartley oscillator whose tone or repe-

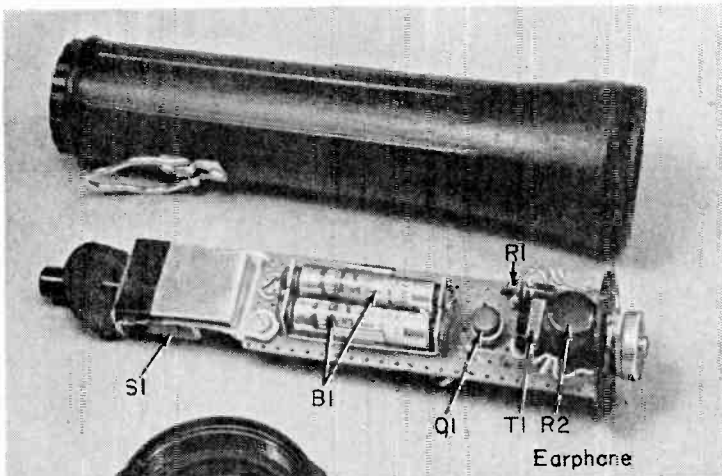

Earphone is mounted with cement on a disc cut from the perforated board.

Switch is mounted on an aluminum bracket, bracket is attached to board.

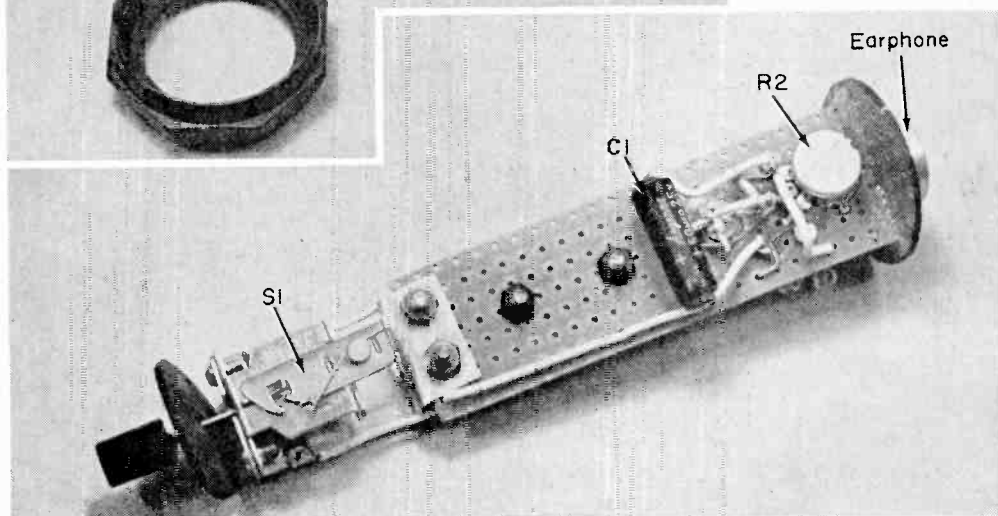

Looking at front end, earphone which is used as a small speaker is protected by flashlight glass disc.

To turn on, remove waterproof end-cap and press SI, which will lock into position. Replace end-cap.

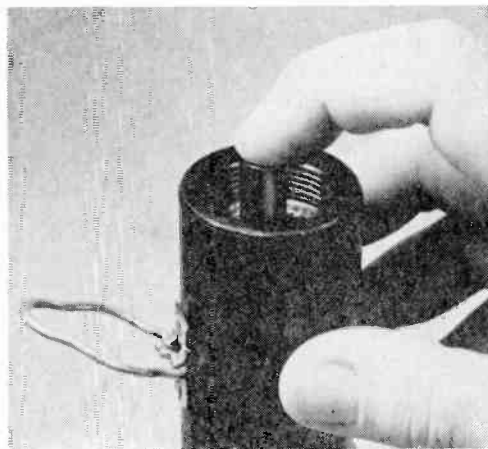
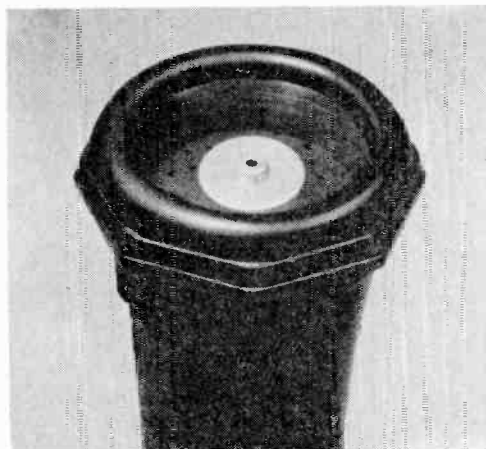

# "CQ FISH"



Completed unit fits into watertight flashlight case after works come out.

tion rate is determined by R/C circuit  $R1$ ,  $R2$  and  $C1$ . By varying potentiometer  $R2$ , you can create any sound from that of a bee to a grasshopper through the high-impedance dynamic earphone.

**Construction.** To build the unit, start by stripping the skin-diving flashlight down to its shell. Remove all switches, springs and hardware. Next, fill all holes with cement, using epoxy or household cement. Make sure the rubber gaskets (included with the original flashlight) seal all the openings when the basic flashlight is reassembled. You can test for leaks by submerging the unit in water and watching for air bubbles.

Cut a perforated mounting board into two pieces. One piece should be  $4\frac{1}{2}'' \times 1\frac{3}{8}''$ ; the other is formed into a circle of about  $1\frac{1}{2}''$ , or to fit the lens area of your flashlight. Cement the circle to the end of the rectangular board as shown in the illustrations. The bracket for switch  $S1$  is formed from scrap aluminum.

After you assemble the major components on the board, paying careful attention to the polarity of  $Q1$ ,  $C1$  and  $B1$ , cement the back of the earphone to the center of the circular piece.

**Testing.** When the wiring is completed, turn the unit on and listen for the tone at the earphone. Varying the setting of  $R2$  should change the tone. If the unit works, coat all wiring with polystyrene "Q"-dope to minimize corrosion damage.

Now assemble the circuit into the flashlight housing and, once again, submerge the unit to make sure that it is watertight. If all is well, watch those fish sit up and QRZ!

-50-

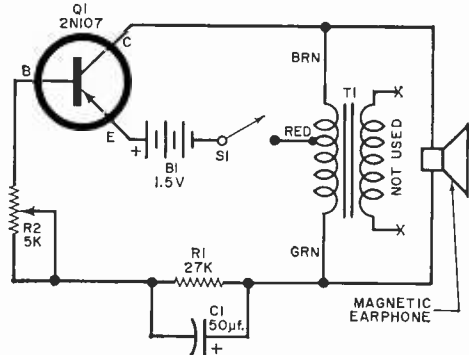

Switch  $S1$  is a push-on/push-off type, and  $R1$ ,  $R2$ ,  $C1$  determine frequency varied by potentiometer  $R2$ .

## PARTS LIST

- $B1$ —1.5-volt battery (two Eveready #912's in parallel)
- $C1$ —50- $\mu$ f., 25-volt miniature electrolytic capacitor
- $Q1$ —2N107 transistor or equivalent
- $R1$ —27,000-ohm,  $\frac{1}{2}$ -watt resistor
- $R2$ —5000-ohm miniature potentiometer
- $S1$ —S.p.s.t. locking push-button switch
- $T1$ —Subminiature output transformer; 500-ohm, center-tapped primary, 8-ohm secondary (Lafayette 99-G-6129)
- 1—Pressure-proof skin-diving flashlight (U.S. Divers, Voil, Sportsways, or equivalent—available at most sporting goods stores)
- 1—Battery holder, two-cell type
- 1—High-impedance earphone, 7000-ohm dynamic (Lafayette 40-G-7801)
- Misc.—Knob, transistor socket, switch bracket, perforated mounting board, wire, solder

COINED during World War II, "push the panic button" has since become a colorful and descriptive addition to our everyday language. The phrase is used to describe any hastily conceived and ill-advised command or management reaction to an emergency situation that sends all hands racing helter-skelter in a flurry of frantic and ineffectual activity. In response to the popular appeal of the idea, dummy panic buttons can be found strategically located in the offices of many enlightened business executives.

This article describes the construction of an electronic panic alarm that will electrify the deadest office. When activated, the device sounds off with a piercing blast of acoustical energy that combines the most desirable tonal character-

# BUILD PANIC ALARM

By **ROY E. PAFENBERG**, 'W4WKM

***Guaranteed to start***

***a panic every time***

***an adventurous***

***soul pushes***

***that button***







The author mounted his alarm in a sloping front cabinet, but there is no reason why other design housings won't work as well.

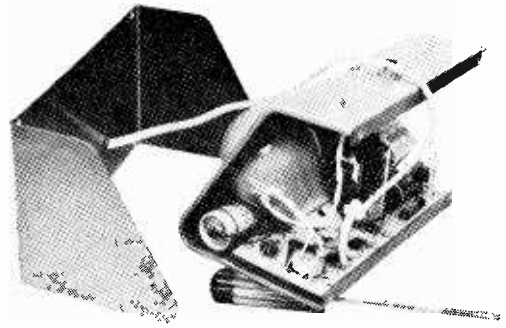

Perforated board is held to the bottom of the box with four bolts. The 25-watt lamp has no socket; the connections are soldered in place.

As mentioned above, the layout can be modified to suit the individual requirements of the builder. If you want to follow the author's model, this photograph will spot some of the more important components for you. Be sure that none of the circuitry contacts the metal chassis. See text for parts value changes to alter output tone.

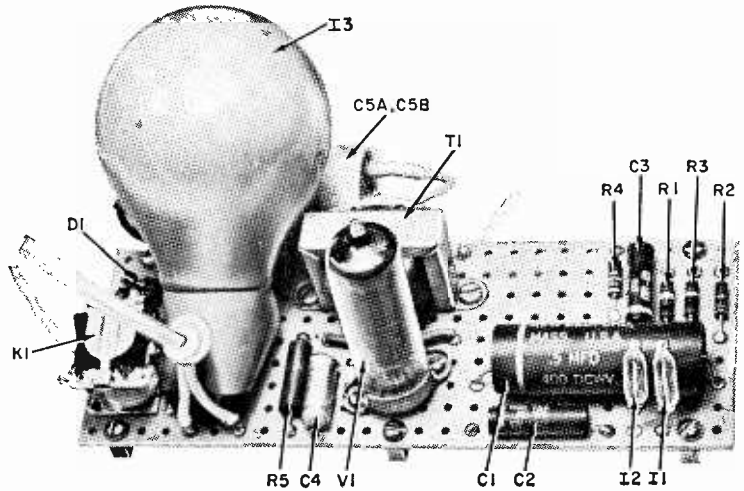

istics of a fire engine siren, a submarine diving alarm, and a hound with its tail caught in the screen door.

The panic alarm is activated by a deceptively labeled *PUSH TO TEST* switch. A special latching relay circuit is provided to keep the alarm sounding until the a.c. line cord is disconnected. The panic-stricken confusion that continues until someone finally unplugs the power cord adds greatly to the effectiveness (?) of the device.

A simple, easily wired circuit is used in the panic alarm. As shown in the photographs, the circuitry is housed in a small sloping-panel aluminum cabinet (Bud AC-1613). The front panel contains a speaker cutout with a red painted grille and a large matching, attention-getting red lamp. The *PUSH TO TEST* switch is mounted on the top of the cabinet.

**Theory.** The heart of the circuit is a rather unusual dual neon lamp relaxation oscillator. Because of the relatively long time constant of capacitor *C1* and resistor *R2*, the circuit of lamp *I1* oscillates at a subaudible rate. This results in a varying d.c. voltage at the junction of resistors *R1* and *R2*.

The time constant of capacitor *C2* and resistor *R3* is such that the circuit of lamp *I2* oscillates at an audible rate. Since the voltage for this circuit is obtained at the junction of *R1* and *R2*, the output frequency of this oscillator is swept at a rate determined by the frequency of the *I1* oscillator. Time constants of both circuits have been chosen to produce a very distinctive swept-tone siren effect. Output of the *I2* oscillator is coupled to a conventional audio output stage through capacitor *C3*.

A 25-watt, 117-volt red-frosted lamp

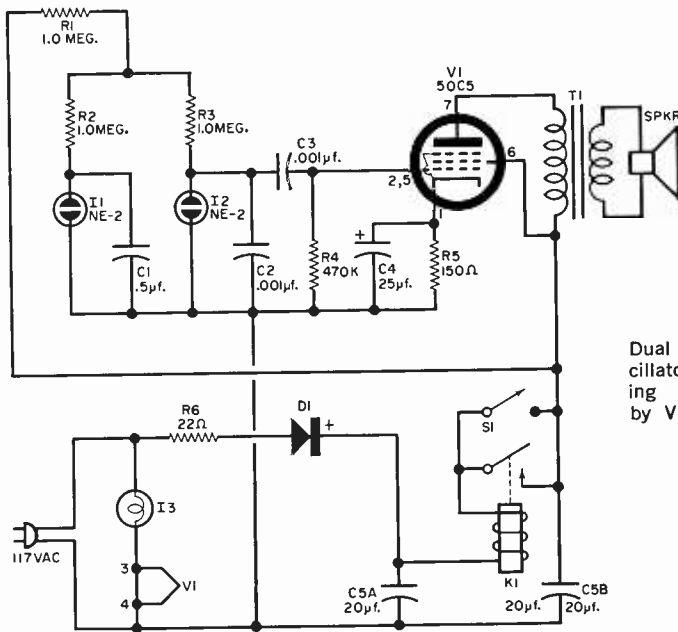

Dual neon lamp relaxation oscillator gives rising and falling siren effect. Amplified by V1, a 50C5, it is LOUD.

#### PARTS LIST

C1—0.5- $\mu$ f., 400-volt capacitor  
 C2, C3—0.001- $\mu$ f., 600-volt capacitor  
 C4—25- $\mu$ f., 25-volt electrolytic capacitor  
 C5—20-20  $\mu$ f., 150-volt electrolytic capacitor  
 D1—Silicon diode, 750-ma., 400-volt PIV (Lajayette SP-241 or equivalent)  
 I1, I2—NE-2 neon bulb  
 I3—25-watt, 117-volt light bulb, red frosting  
 K1—S.p.d.t. relay, 6-volt, 335-ohm coil (Potter & Brumfield RS5D or equivalent)  
 R1, R2, R3—1-megohm,  $\frac{1}{2}$ -watt resistor  
 R4—470,000-ohm,  $\frac{1}{2}$ -watt resistor

R5—150-ohm, 1-watt resistor  
 R6—22-ohm,  $\frac{1}{2}$ -watt resistor  
 S1—S.p.s.t. push-button switch, normally open, momentary contact (Switchcraft FF-1001 or equivalent)  
 T1—Audio output transformer, 2000-ohm plate winding to 3.2-ohm voice coil winding  
 V1—50C5 tube  
 Misc.—4" speaker (3.2-ohm voice coil), cabinet (Bud Radio AC-1613 used by author), lamp cord, mounting hardware, perforated circuit board, solder, wire, etc.

(I3) is used in the power supply section of the circuit. This lamp, connected in series with the 50C5 tube heater, serves the dual function of indicator light and series-dropping resistor to reduce the line voltage to the 50 volts required by the tube heater.

The B+ power supply uses diode D1 in a conventional half-wave rectifier circuit. The winding and the normally open contacts of relay K1 are connected in series with the B+ output. The normally open contacts of the PUSH TO TEST switch are connected in parallel with the relay contacts. When this switch is closed, the charging current of capacitor C5b causes the relay to operate, and the current drawn by the 50C5 tube holds the relay closed until power is removed

by disconnecting the a.c. line power cord.

**Construction.** Although the circuit is noncritical and parts placement can be varied, the method of construction shown in the photographs is convenient. If a different method is used, two precautions must be observed. Since the circuitry is connected directly to the power line, care must be used to insure that no portion of the circuit makes connection to the metal cabinet. Secondly, in the relay specified for use as K1, the movable contact is connected directly to the frame of the relay. Therefore, any method of construction used must provide an insulated mounting for this component.

The speaker is mounted on the panel  
 (Continued on page 146)

# POCKETABLE METRONOME

*A variable-speed pacer will be a boon for any tyro instrumentalists*

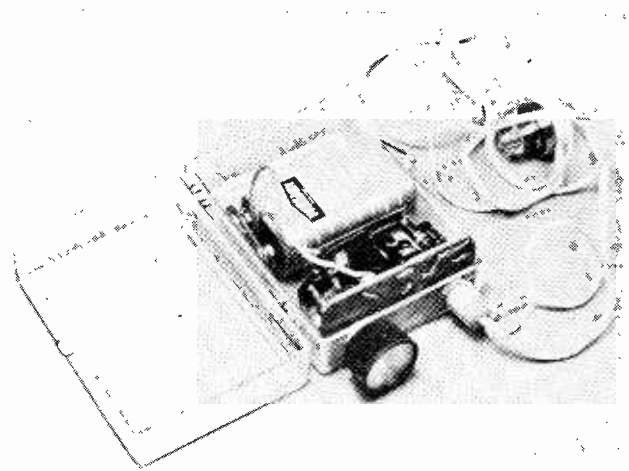

**P**EOPL**E** are rhythm-conscious, and if you are learning to type, play an instrument, dance, exercise, or any of countless other rhythmical functions, this metronome will mark the beat for you at a rate of from 80 to 300 clicks per minute. It is small enough to fit in a pocket, and the earphone stores nicely in the roomy case.

The metronome circuit is a simple relaxation oscillator with a 20- $\mu$ f. emitter bypass capacitor (*C2*) to stabilize the circuit. Two holes in the circuit board are enlarged to accept jack *J1* and potentiometer *R1*. As these components also hold the circuit board to the plastic case, the jack hole should be enlarged sufficiently to pass the collar of the jack.

Before permanently wiring the circuit, check the range of clicks. If they are too slow, decrease the resistance of *R2*; if they are too fast, increase *R2*'s value. Potentiometer *R1* has a tapered resistance, and both outer terminals should be tried to see which gives the greater spread of click range.

Metronomes are usually bulky affairs, never thought of as portable. This one is a departure from the norm, with more applications than a normal metronome could shake its pendulum at!

—Sal Stella

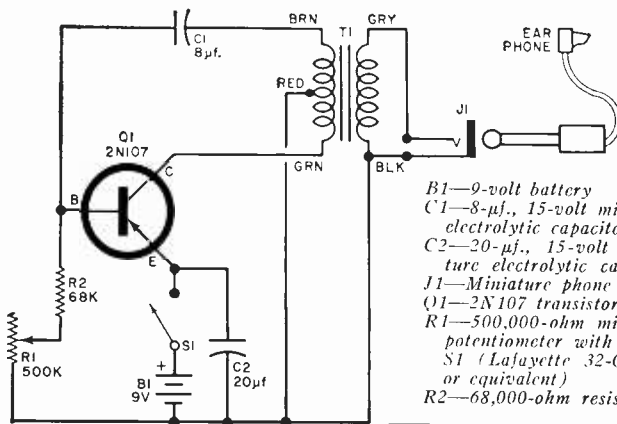

Switch *S1*, on back of *R1*, closes when knob is turned; *R1* varies click speed.

## PARTS LIST

*B1*—9-volt battery  
*C1*—8- $\mu$ f., 15-volt miniature electrolytic capacitor  
*C2*—20- $\mu$ f., 15-volt miniature electrolytic capacitor  
*J1*—Miniature phone jack  
*Q1*—2N107 transistor  
*R1*—500,000-ohm miniature potentiometer with switch *S1* (Lafayette 32-G-7368 or equivalent)  
*R2*—68,000-ohm resistor

*S1*—S.p.s.t. switch (part of *R1*)  
*T1*—Transistor miniature output transformer (Lafayette 99-G-6127 or equivalent)  
 1—6-ohm earphone  
 1—Battery connector  
 1— $\frac{7}{8}$ " x  $1\frac{1}{4}$ " circuit board  
 1—Plastic hinged box or other housing approx. 1" x 2" x  $2\frac{3}{8}$ "

**It's night. Suddenly a tire blows. You pull over to the side, but another car is coming up fast from behind...**

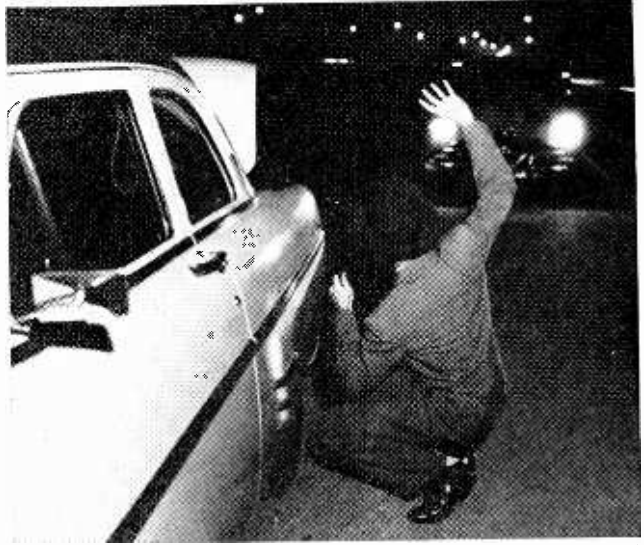

Photo courtesy National Safety Council

# For Greater Safety Flash Those Lights!

By LOUIS F. CORTINA

**I**F YOU'VE ever had to stop your car on or near the road while driving at night, you know how nerve-wracking this experience can be. Most of us have thought at one time or another of buying flares for use in such an emergency, but how many drivers actually carry them? The news stories concerning rear-end collisions with stalled vehicles point up the danger involved in not having some positive means available to alert other drivers.

Of course, you can pump your brake pedal to flash your rear lights, but this

becomes tiresome very quickly. However, there is a practically tireless device on almost all cars which can be used to perform the same job—the flasher which operates your turn-signal lights. Some stalled drivers have the presence of mind to use this device in its normal manner, that is, to operate the turn signals. The danger here is that the driver in back may not realize until too late that the car is not moving, but standing still.

**Two-Light Flasher.** The additional wiring needed to make the flasher operate both rear lights is quite simple. The

Fig. 1. A two-light flashing arrangement requires only the connection of a s.p.s.t. switch between the flasher and brake-switch leads.

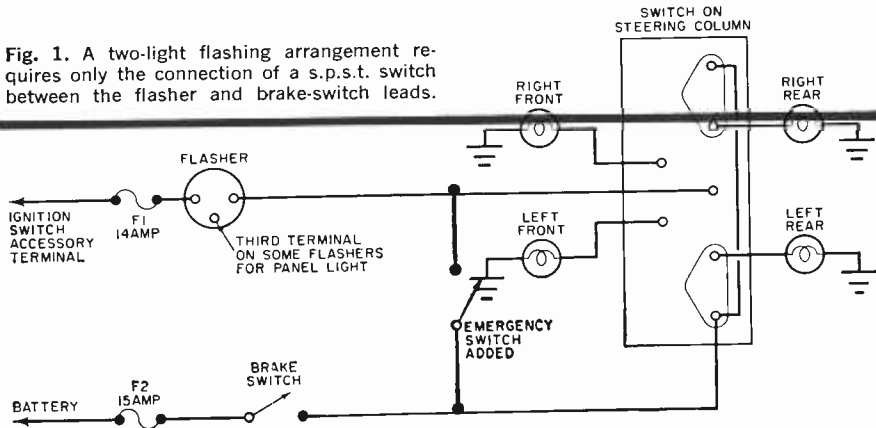

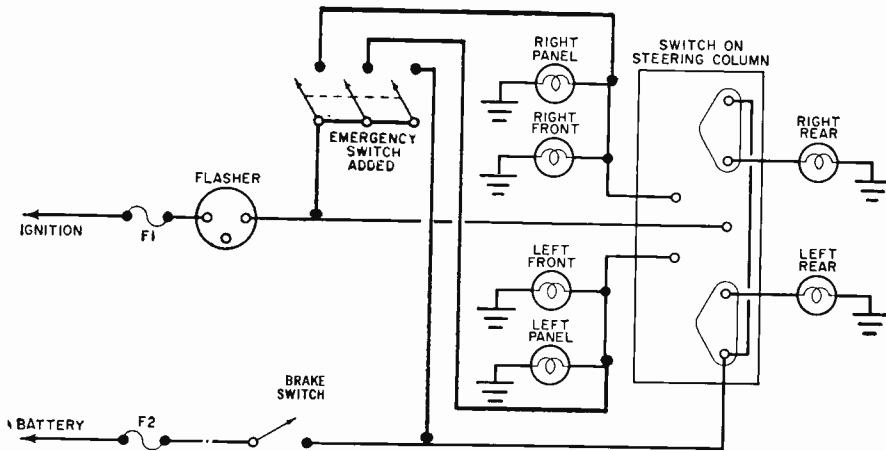

Fig. 2. Connected as indicated, a 3-p.s.t. switch provides four-light front and back flashing.

usual turn-signal switch has six leads; one from the flasher, one from the brake switch, and four leads to the various exterior lights. When the turn signal switch is in the center—or neutral—position, there is continuity between the brake-switch lead and the two leads which go to the rear lights of the car. If a path is provided from the flasher lead to the brake-switch lead, the rear lights will receive power through the flasher and will blink on and off in the same manner as the turn-signal lights, making an attention-getting device.

Figure 1, on page 15, shows a typical wiring layout and the necessary modification. The switch used is a s.p.s.t. type, and may be a toggle, rotary, or push-pull device rated to carry 3-5 amperes. Since most cars normally use two lights for signaling, one in the front and one in the back, the flasher will be operating under its normal load when flashing the two back lights.

One exception is some General Motors cars which normally flash two lights on either side in the back, and one on either side in the front. If the flasher is connected to the four back lights, it will be operating with an overload and will run fast. To overcome this deficiency, one of the heavy-duty, variable-load flashers, designed for truck service or for vehicles towing a trailer, can be substituted for the original flasher. These variable-load units, which are manufactured by Ideal and Tung-Sol, will operate from one to eight lights of 21 or 32 candle power while maintaining a constant flashing

rate. Replace a 6-volt flasher having three terminals with a Type 535 or 2535, a 12-volt unit having two terminals with a Type 536 or 2536, and a 12-volt unit having three terminals with a Type 550 or 2550.

Most cars made since 1949, as well as some earlier models, have a flasher socket under the instrument panel on the driver's side. It is only necessary to remove the original flasher and plug in the heavy-duty unit. Chrysler products from 1949 to 1954 have the flasher mounted on the engine side of the firewall. For those cars which do not use a flasher socket, remove the leads from the original unit and wire them to the corresponding terminals of the replacement unit.

**Four-Light Flasher.** While the simple hookup illustrated in Fig. 1 can be used in most states, California requires that any warning-light setup include "four or more approved turn-signal lamps . . . at least two of which must be toward the front and at least two toward the rear of the vehicle." Your local motor vehicle department can tell you the rules that apply in your area.

The added wiring needed to connect the flasher to all four light leads is not very involved. A three-pole, single-throw switch, either rotary or toggle, will do the job. An advantage of this method is that the panel indicator lights, which are usually paralleled with the corresponding front light on late-model cars, will also be energized. This keeps you from

(Continued on page 148)



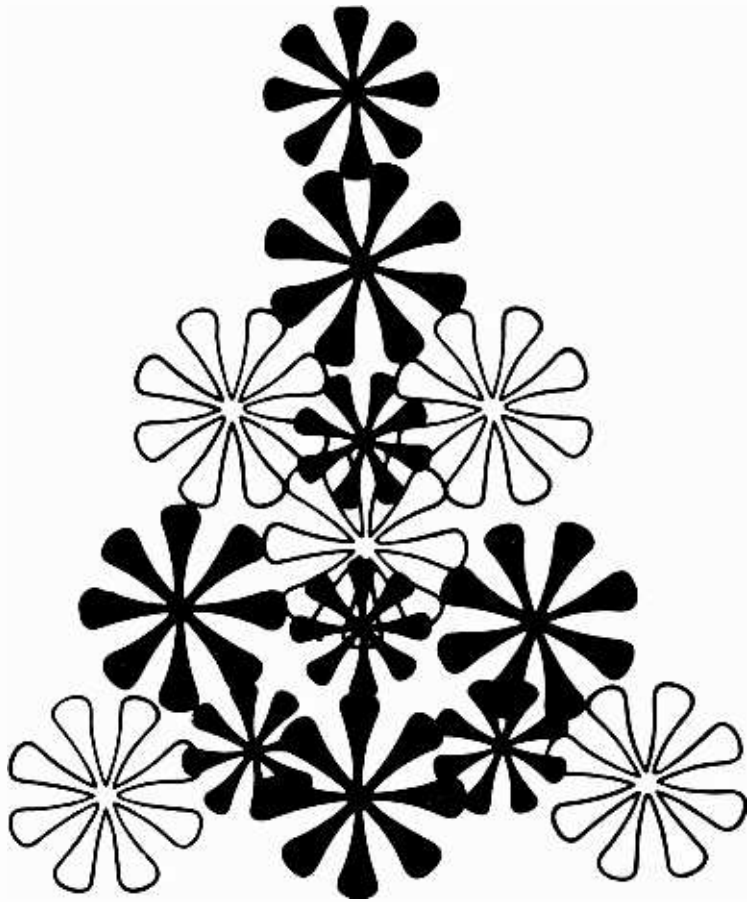

# Electronic Candles Dance and Glow

Ordinary incandescent bulbs become sparkling, flickering holiday decorations when they're powered by the Electronic Candlelighter

By **JEFF H. TAYLOR**

**T**HERE'S NOTHING LIKE the warm glow of candlelight for festive occasions. Unfortunately, in modern times, the candle flame with its rhythmic, yet random, light has been largely replaced by the more intense, steady brilliance of incandescent bulbs. This article describes a method of reproducing the effect of candlelight, however, using ordinary electric light bulbs. And, unlike the candle, there's no smoke, melted wax, or fire hazards to contend with. You simply plug a lamp or string of decorative lights into the "Electronic Candlelighter," sit back, and enjoy the age-old effect of flickering, dancing candlelight.

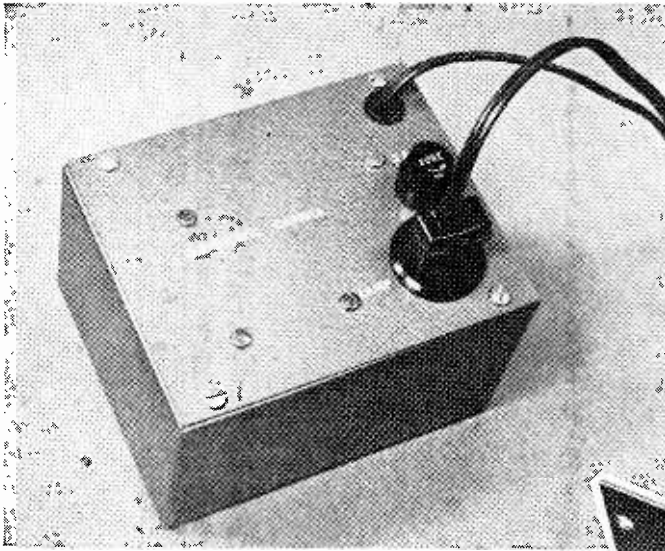

The Candlelighter is built into a 3" x 4" x 5" aluminum box with a fuse and an output socket mounted on top panel for one lamp or a string of lights.

Component layout is shown in the photo below and those on the opposite page. Note R8 mounted to D4 and SCR1 by its leads; the exact value of this resistor depends on the load wattage, and can be estimated by using the table on page 19. Various substitute unijunction transistors such as the 2N489, 2N490, etc., series can be used in place of the 2N1670; some SCR's will replace the T140A2, including the 2N1602, 2N1603, T40A3, or T140A4.

**How It Works.** The "Electronic Candlelighter" provides a half-cycle sine wave to the lamp(s) continuously, plus other random currents during the remaining half-cycle. These random signals are generated by three neon-bulb relaxation oscillators operating at three slightly different frequencies. The oscillators beat with each other and the 60-cycle line frequency to produce a flicker in the lamp which is plugged into the socket.

The unit has three basic circuits: the neon relaxation oscillators, the driver, and the power control circuit. The oscillators are capacitively coupled to the driver through C4, C5, and C6. These capacitors prevent oscillator interaction.

The neon lamp oscillators are supplied with a negative charging potential so that when they fire they produce the positive-going waveform necessary to forward-bias unijunction transistor Q1.

The driver circuit consists of the transistor (Q1) to which the oscillators are coupled. Base 2 of the unijunction is supplied with positive pulses through diode D3. The voltage on base 2 has a peak excursion of about 15 volts. The oscillator pulses at the emitter of Q1 which are in phase with the half-cycle positive pulses on base 2 produce pulses at base 1 which are coupled to the silicon-controlled rectifier, SCR1. Diode D2 provides d.c. restoration without loading the signal portion of the oscillator output.

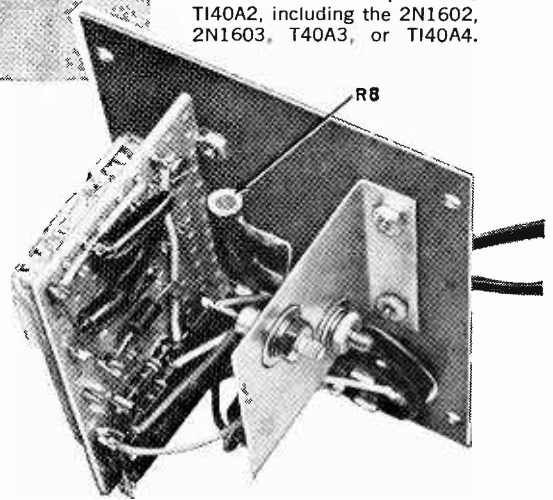

#### PARTS LIST

- C1-C6—0.1- $\mu$ f., 200-volt miniature paper capacitor
- D1, D3—1N2071 silicon rectifier (T1)
- D2—1N2070 silicon rectifier (T1)
- D4—1N254 silicon rectifier (T1)
- F1—3-amp 3.1G fuse in panel-mounting holder
- I1, I2, I3—NE-2 neon bulb
- Q1—2N2160 unijunction transistor (T1)
- R1—5.6-megohm,  $\frac{1}{2}$ -watt resistor
- R2—4.7-megohm,  $\frac{1}{2}$ -watt resistor
- R3—3.9-megohm,  $\frac{1}{2}$ -watt resistor
- R4—10,000-ohm, 10-watt resistor,  $\pm 5\%$
- R5—390-ohm,  $\frac{1}{2}$ -watt resistor
- R6—1000-ohm, 2-watt resistor
- R7—47-ohm,  $\frac{1}{2}$ -watt resistor
- R8—See text
- SCR1—T140.12 silicon-controlled rectifier (T1)
- 1—3" x 4" x 5" aluminum box
- 1— $2\frac{1}{4}$ " x  $2\frac{1}{2}$ " piece of light aluminum
- 1— $2\frac{1}{2}$ " x 4" piece of perforated phenolic board
- 1—Panel-mounting a.c. receptacle
- Misc.—Transistor socket, line cord and plug, press-in solder terminals, wire, solder, hardware, rubber grommet, decals, etc.

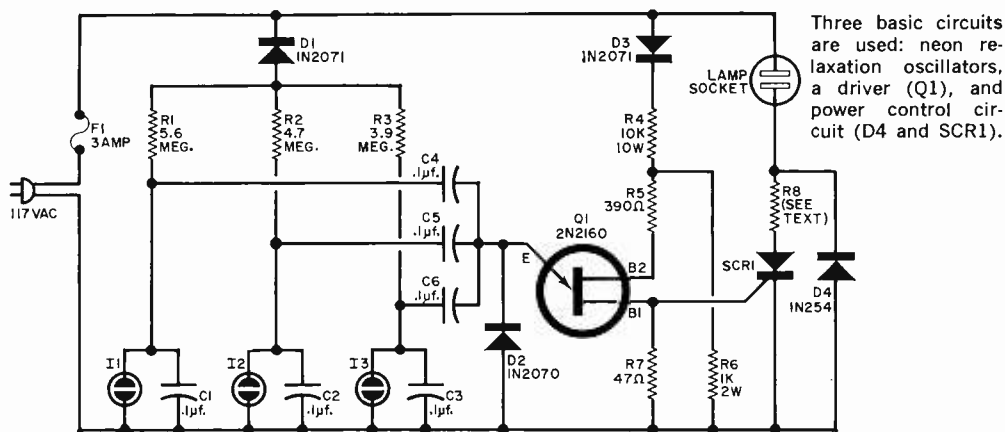

Bend piece of light aluminum to form heat sink for D4 and SCR1; make sure they're not shorted to it.

Remaining parts are neatly laid out on a phenolic board which is mounted to box with small brackets.

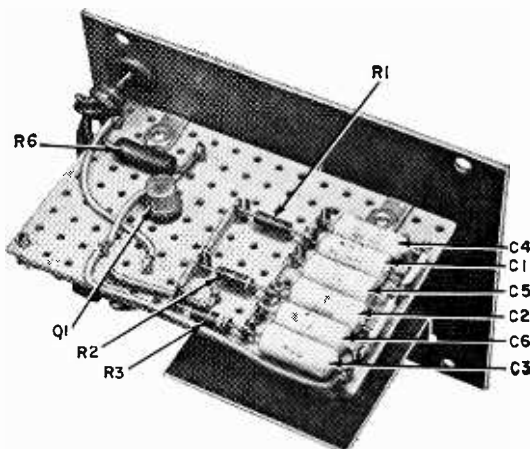
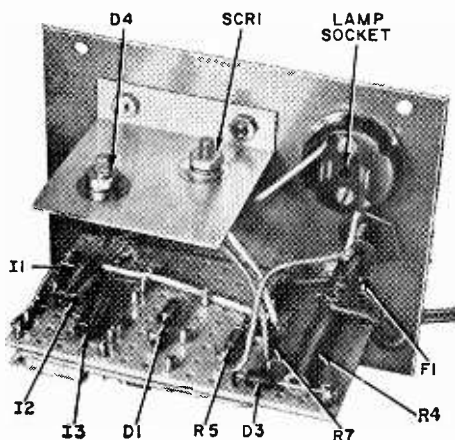

### How to Select Resistor R8

To determine the value of R8, use the table below. Choose the lamp wattage you want to use and read across for the approximate resistance value and wattage of the resistor that will give the best candlelight effect. Although no resistor is recommended for loads above 100 watts up to the unit's maximum rating of 300 watts, it may be desirable to use one in some cases, especially with strings of decorative bulbs. Optimum resistor values will range from 1 to 20 ohms at 20 watts.

Bulb Wattage	Resistance (ohms)	Power (watts)
7½	325	1
15	250	2
25	200	5
40	150	5
50	125	5
60	100	10
75	80	10
100	50	10

The power control circuit consists of a conventional rectifier (D4) which continuously provides half-cycle a.c. to a lamp load up to 300 watts, and the silicon-controlled rectifier (SCR1) which supplies the "flicker" pulses. A resistor selected to match the wattage of the load, R8, is placed between the anode of the silicon-controlled rectifier and the load to reduce the magnitude of the flicker, thereby producing a more realistic candle flame effect.

**Building the Unit.** As with the "Spook-in' Light" (a somewhat similar project in POPULAR ELECTRONICS, Sept., 1964), it is imperative that none of the components in the "Electric Candlelighter" come in contact with the 3" x 4" x 5" aluminum box used as a cabinet, or the

## PARTS PROBLEMS?

We can supply parts kits and circuit boards for:

Adjustable Speech Filter

Bargain Page Amplifier

This Issue—and

Ultrasonic Sniffer Mar. 1963

Ultrasonic Trans. Sept. 1964

RC Receiver Apr. 1965

RC Transmitter June 1965

Others

Send for free catalog listing these projects and others plus circuit board type components

## DEMCO

Box 16297

San Antonio, Texas 78216

CIRCLE NO. 5 ON READER SERVICE CARD

*To Home or Shop...  
for business or personal use!*

"Messenger" Citizens Radio opens up the exciting field of personal communications to everyone — in any application. Used by builders, contractors, trucking, delivery services, garages on-the-job—ideal for sportsmen, hunters, fishermen and campers! Anyone can operate — license issued on request. Investigate the "Messenger" line — nation's most popular, most reliable Citizens Band equipment!

### YOUR OWN 2-WAY RADIO



**JOHNSON**  
CIRCLE NO. 14 ON READER SERVICE CARD



Write Today

**E. F. JOHNSON CO.**

2521 10th Av. S.W. • Waseca, Minn. 56093



aluminum heat sink on which *SCR1* and *D4* are mounted. Use a 2½" x 4" piece of Vectorbord and press-in solder terminals for mounting all of the other components, following the general layout shown in the photographs. The semiconductors are all Texas Instruments types, but equivalent units made by other manufacturers could be employed instead.

Due to the fact that NE-2's tend to be photosensitive, cover each one with black plastic tape before wiring them in place. Transistor *Q1* is mounted in a socket which is force-fitted into a hole drilled in the Vectorbord; the mounting board is attached to the front panel of the cabinet with two small angle brackets.

To make the heat sink, simply bend a 2¼" x 2½" piece of light aluminum to form a mounting bracket at one end (see photos). Drill mounting holes in the heat sink for *SCR1* and *D4*, and mount them with mica insulating washers. As an additional safety measure, check with an ohmmeter to make sure there is no electrical contact between the diodes and the heat sink.

To complete the unit, mount the lamp socket, fuse holder, heat sink and circuit board to the front panel, and install the line cord through a hole lined with a rubber grommet.

**Operation.** Select R8 by referring to the table on page 19. The resistance values are not critical; simply select one close to the recommended value. Remember to calculate the *total wattage* if the unit is to be used with a string of decorative lights rather than with a single bulb. Check the wiring carefully, then try the unit out in a dimly lit room.

For a festive or romantic atmosphere, use electronic candlelight! —30—



"And this is Fred's quote, workshop, unquote."

# Choose Your Tailor-Made Course in N.T.S. "PROJECT METHOD" ELECTRONICS!

Now! N.T.S. — one of America's oldest leading home-study and resident technical schools — offers you **GREATER CAREER OPPORTUNITIES IN ELECTRONICS**. N.T.S. "Project Method" home training lessons are shop-tested in the Resident School in Los Angeles. You work on practical job projects, learn to use shop manuals and schematics. Your N.T.S. training is individual. You proceed at your own pace. The Schools' practical methods, plus more than 60 years of experience, have helped thousands of students all over the world to successful careers. Prepare now for a secure future in one of 8 N.T.S. Electronics Courses designed to fit your own particular needs.



Work on the electronic "brains" of industry — computers, data processing and other automation equipment. Become a TV-Radio Technician, an electronics field engineer, or succeed in your own business.

## CHOOSE YOUR FIELD — INSURE YOUR FUTURE!

- 1 ELECTRONICS-TV-RADIO-SERVICING & COMMUNICATIONS** A basic course thoroughly covering fundamentals of electronics, radio, TV servicing and communications.
- 2 MASTER COURSE IN ELECTRONICS-TV-RADIO, PLUS ADVANCED TV & INDUSTRIAL ELECTRONICS** This course covers everything included in Course No. 1 plus Automation and every phase of the Electronics industry.
- 3 FCC LICENSE** Preparation for this government license essential for interesting jobs in radar, radio, television, communications, guided missiles, many others. Upon completion of this course, if you do not pass the FCC exam for a 1st Class Commercial Radiotelephone License your tuition will be refunded.
- 4 RADIO SERVICING (AM-FM-Transistors)** Train for radio sales and service with dealer or distributor.
- 5 TELEVISION SERVICING (Including Color)** Covers installation, adjustment, repair and servicing of black and white and color television . . . prepares you for your own sales and service business.

- 6 STEREO, HI-FI AND SOUND SYSTEMS** A growing field. Prepares you to build, install and service modern sound equipment for home or industry.
- 7 BASIC ELECTRONICS** Gives you the fundamentals you must know to build on for a future Electronics career. Also offers an excellent background for Salesmen, Purchasing Agents, and others in Electronics.
- 8 ELECTRONICS MATH** Simple, easy-to-follow instructions in the specialized math you need in many electronics jobs.

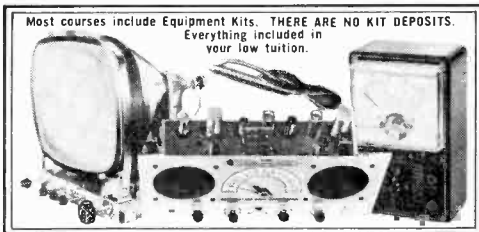

Most courses include Equipment Kits. THERE ARE NO KIT DEPOSITS. Everything included in your low tuition.

### CLASSROOM TRAINING AT LOS ANGELES

You can take classroom training in our famous Resident School at Los Angeles in Sunny Southern California. N.T.S. is the oldest and largest school of its kind. Associate in Science Degree also offered in our Resident Program. Check Resident School box in coupon for full details.

### MAIL COUPON TODAY FOR FREE BOOK AND SAMPLE LESSON

In Field of Your Choice, You enroll by Mail — and Save Money. No Salesmen. This means lower tuition for you. Accredited Member N.H.S.C.

### HIGH SCHOOL AT HOME

Learn easily. New modern method. National also offers accredited high school programs for men and women. Take only subjects you need. Study at your own pace. Latest approved textbooks — yours to keep — everything included at one low tuition. Check High School box in coupon for information.



### NATIONAL TECHNICAL SCHOOLS

4000 S. Figueroa St., Los Angeles, California 90037

Please Rush FREE Electronics "Opportunity Book" and sample lesson on course checked below:

- Electronics-TV-Radio Servicing & Communications
- Master Course in Electronics-TV-RADIO Advanced TV & Industrial Electronics
- FCC License
- Radio Servicing (AM-FM-Transistors)
- Television Servicing (Including Color)
- Stereo, Hi-Fi and Sound Systems
- Basic Electronics
- Electronics Math

Dept. 221-105

Name \_\_\_\_\_ Age \_\_\_\_\_

Address \_\_\_\_\_

City \_\_\_\_\_ State \_\_\_\_\_ Zip \_\_\_\_\_

- Check here if interested ONLY in Classroom Training at L.A.
- Check here for High School Department Catalog only.



**NATIONAL TECHNICAL SCHOOLS**  
WORLD-WIDE TRAINING SINCE 1905

4000 S. Figueroa St., Los Angeles, California 90037

CIRCLE NO. 35 ON READER SERVICE CARD



# ADD

## D.C. restoration to TV

BY CHARLES E. COHN

When they cut the costs they leave out this important picture circuit

ALTHOUGH the d.c. restorer was regularly used in the earliest TV sets, it is a neglected feature in today's receivers. The omission is regrettable, since this circuit makes a valuable contribution to picture fidelity. However, it is not difficult to add to a set.

The need for d.c. restoration stems from the manner in which a signal is generally applied to the picture tube. To simplify comparison, assume the detector's video polarity is such that a positive signal (see drawing) corresponds to black information, with smaller voltages corresponding to lighter gray shades until white is reached with the smallest voltage.

If this signal is directly coupled from detector to picture tube, a given voltage always corresponds to the same shade. Reproduction of the black-to-white scale would then always be correct, provided only that the receiver's brightness control is properly set.

**Where Restorer Comes In.** While some TV receivers use d.c. coupling to the picture tube, most sets use RC coupling.

The d.c. level of the signal is thus removed through the coupling capacitor, with the average amplitude of any signal being placed at the same level. This permits the standard black level to shift, depending on make-up of the signal at any given moment.

The drawing illustrates this action for typical signals. The first line shows a signal with the blacks and whites evenly distributed. The average level to the CRT, without restoration, is where it should be. The signal in the second line is mostly black. When capacitor coupling, however, moves the average level down toward gray, the scene is reproduced lighter than it should be. Also, with sync pulses not reaching the black level, retrace lines become visible. With a mostly white signal (third line), the shift toward gray makes the picture darker than it should be.

Where neither direct coupling nor a d.c. restorer exists, the latter can be added. The circuit senses the sync pulses, which are always at the same level just

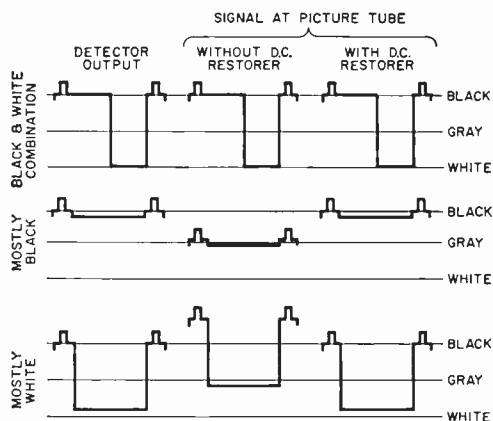

Without d.c. restoration, mostly black pictures tend to drop and mostly white scenes tend to rise into the gray area, reducing the dynamic contrast range.

beyond black, and adjusts CRT bias accordingly to compensate for the shift produced by capacitive coupling.

The circuit shown here is easy to install in an existing set, can be used wherever a video signal is applied to the picture-tube cathode, and the brightness control is also located there. This arrangement is usual. The circuit requires the addition of only one tube, two capacitors, and three resistors.

**Circuit Operation.** With the large cathode resistance, *R1*, *V1* is almost cut off. Positive video signal is applied to its grid. Without *C1* in the cathode, *V1* plate current would increase as video be-

comes more positive, the cathode voltage following the grid voltage. However, *C1* charges the cathode voltage to the most positive part of the signal, the sync pulses, and holds *V1* cut off over the rest of the cycle. The voltage on *C1* is applied to the CRT grid. Thus the CRT grid-cathode potential is always constant on a sync pulse.

Between sync pulses, *C1* slowly discharges through *R1*. The time constant of this combination is comparable to the duration of one frame, so that the circuit will not respond to more rapid changes in average level. However, the time constants of the coupling circuits in the video amplifier are sufficient to hold the black level for one frame.

Installation of the circuit poses no special problems. For *V1*, use that variant of the 6AU6 whose heater characteristics can be most conveniently incorporated in the set's heater circuit. Some point having no more than 150 volts of "B+" must be found for the plate and screen supply. Note that *C2* is connected directly to the end of the video-amplifier plate load resistor closer to the plate and after any of the peaking coils. This minimizes the effect of the added stray capacitance on the high-frequency response of the video amplifier.

The CRT grid is removed from its existing connection and taken to the cathode of *V1*. Many sets have retrace blanking circuits connected to this grid. Such blanking should not be necessary after the revision, with the black level held where it belongs. However, if blanking should still be needed, it can be retained by connecting in the CRT grid lead a resistance approximately equal to resistance to ground of the previous grid circuit. —50—

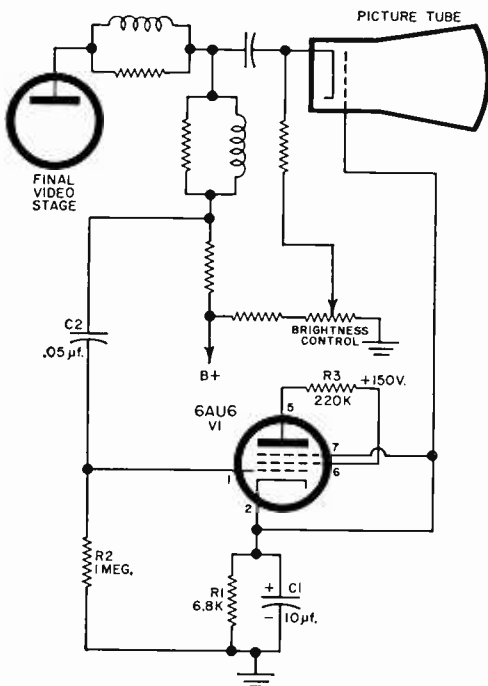

Voltage developed across *C1* is a function of the sync pulse amplitude. This voltage is used to bias the CRT and to maintain relative contrast levels.



Try  
this!

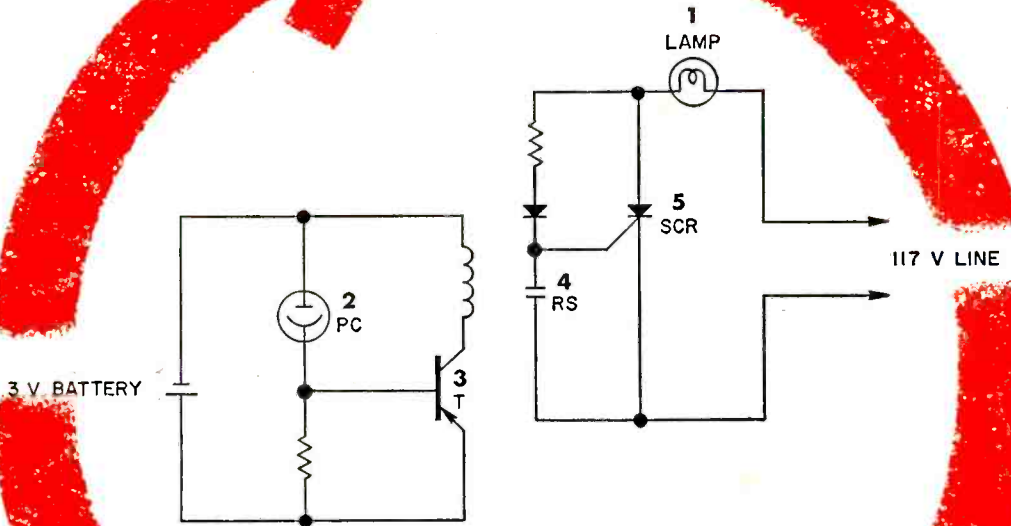

Lamp (1) illuminates photocell (2) which decreases in resistance causing transistor (3) to conduct, causing reed switch (4) to close, cutting off SCR (5), turning off lamp (1), causing photocell (2) to increase in resistance, cutting off transistor (3) allowing reed switch (4) to open, causing SCR (5) to conduct, turning on lamp (1) . . . . .

**Be the first on your block to build  
a "Perpetual Motion" Machine or . . .**

# ... build any number of useful devices with these G-E Electronic Components

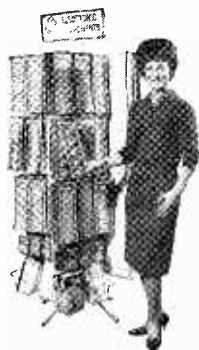

General Electric has a whole line of components that you can use in your home workshop. Look for this display—featuring G-E components at new low prices—at your local electronic distributor's (see listings below for distributor nearest you). All the G-E components listed below are furnished complete with schematic diagrams for building exciting new devices.

**GE-X1 Silicon Controlled Rectifier** for speed control for hand tools, blenders, mixers, lamp dimmers, HO train controls, and automobile alternator regulators.

**GE-X2A Light-Activated Silicon Controlled Rectifier** for photoelectric controls, experimental ignition system, "Slave" photo-flash circuits, and miniature lightweight static relays.

**GE-X3 Silicon Controlled Rectifier** for battery chargers, electroplating, relay replacement, or low voltage controls operating from auto or boat batteries.

**GE-X4 Silicon Rectifier** for Hi-Lo lamp dimmers, motor speed controls, battery chargers, and in conjunction with GE-X1 or GE-X3 for full wave SCR light dimmers or DC power supplies.

**GE-X5 Silicon Controlled Rectifier** for simple remote controls, temperature controls, alarm systems, and many more.

**GE-X6 Photocell** for relay controls, automatic light flashers, remote indicator, and punched card or tape readouts.

**GE-X7 Reed Switch** for light flashers, burglar alarms, liquid-level controls, weight-measuring devices, temperature limiters, multiple relays, and many more.

**GE-X8 Transistor** for light flashers, light target, triggered light source, oscillators, direct-coupled amplifiers, and bistable lamp driver circuitry.

**GE-X9 Transistor** for medium-power amplification and switching with GE-X8 for light flasher, light target, or triggered light source.

**GE-X10 Unijunction Transistor** for high-precision tachometers, oscillators, timing circuits, voltage sensing circuits, SCR firing circuits, and bistable circuits.

**GE-X11 Zener Diode** for high-precision tachometer for automobile-type ignition systems.

**GE-M100 Transistor** for citizens band receiver and control unit (27 mc).

**2N107 Transistor** for simple audio amplifiers; one, two, or three-transistor radios; code practice oscillator, and loudspeaker audio amplifiers.

**2N170 Transistor** for three-transistor and pocket radios, direct-coupled amplifiers, pre-amplifiers, and many more.

**2N2160 Unijunction Transistor** for transistor metronome, code practice oscillator, timing circuits, voltage sensing circuits, SCR firing circuits, and bistable circuits.

## Plus five brand-new components:

**GE-X12 Triac** for AC lamp dimming, temperature controls, motor speed controls, and many more.

**GE-X13 Diac**—Diode AC switch for triggering triac and SCR's.

**GE-X14 Thyrector Diode** for limiting voltage transient in any circuit for constant, reliable performance.

**GE-X15 Thermistor** for monitoring temperature changes in water-depth temperature fishing guide, photography liquid bath, fire alarm, house fans, and many more.

**GE-X16 Silicon Controlled Rectifier**—Three-junction SCR for all power switch control applications.

Get **EXPERIMENTER/HOBBYIST** Components from these local G-E Suppliers or write General Electric Company, Owensboro, Kentucky, for the name of the source nearest you.

**ALABAMA**  
Radio Distributing Supply, Anniston  
Southeastern Radio Parts, Anniston, Gadsden, Montgomery, Selma  
James W. Clary Co., Birmingham  
Forbes Distributing Co., Birmingham, Decatur, Mobile  
Reid Distributing, Birmingham  
Signal Supply, Dothan  
Electronic Wholesalers, Huntsville  
Hughes Electronic Sup., Jasper  
Forbes-Godfrey TV Electronics, Montgomery  
Jones Electronics, Muscle Shoals  
Southern Electronics Corp., Opelika

Powell Electronic Supply, Sheffield  
Allen & Jemison, Tuscaloosa

**ALASKA**  
Communications Eng. Co., Anchorage

**ARIZONA**  
Coconino Electronics, Flagstaff  
Metalls Inc., Las Vegas  
Dalia Radio & TV Sup., Mesa, Phoenix  
Arizona Wholesale Sup., Phoenix  
Electronic Distributing Co., Phoenix  
R. V. Weatherford, Phoenix  
Inland Electronic Sup., Tucson

Turn page for more Distributor listings and coupon for FREE Hobby Manual



# EXPERIMENTER/HOBBYIST ELECTRONIC COMPONENTS

## ARKANSAS

David White Radio Sup., Fayetteville, Harrison, Hot Springs, Little Rock, Murree, Pine Bluff  
 Carlton Bates Co., Fort Smith, Little Rock  
 Carter Electronic Supply, Fort Smith  
 Wise Radio Sup., Fort Smith  
 Martin Wholesale, Jonesboro, Paragould  
 Lavender Radio TV Sup., Memphis  
 Springdale Radio & TV Sup., Springdale

## CALIFORNIA

Kleub, Anaheim, Bakersfield, Long Beach, Oxnard, San Bernardino, Van Nuys  
 Orvay Electronics, Anaheim  
 W.R.S.O., Anderson, Calistoga, Petaluma, San Carlos, San Francisco  
 J. C. Arbuckle Wholesale Parts Sup., Bakersfield, Fresno  
 Pacific Electronics, Berkeley, Concord, Richmond  
 Andrews Electronics, Burbank  
 Electronic City, Burbank  
 Hagerty Radio Sp., Burbank  
 Sady's Electronic Sp., Canoga Park  
 West Valley Electric Sales, Canoga Park  
 Wholesale Electronic Specialists, Cathedral City

JSH Electronics, Culver City  
 Southland TV Sup., El Cajon  
 Kimball & Start, El Monte  
 I. F. A. Electronics, Encino  
 Imperial Sound Co., Encino  
 Inland Electronics, Fremont, Modesto  
 Western Electronic Sp., Fresno  
 Santa Monica-Bell Electronics, Gardena  
 Logan Electronics, Gardena  
 R. V. Weatherford, Glendale, San Diego  
 North Valley Electronics, Granada Hills  
 Beacon Electronics, Harbor City  
 Hollywood Radio & Electronics, Hollywood  
 Pacific Radio Exchange, Hollywood  
 Yale Radio Electric, Hollywood  
 Martin Distributing, Huntington Park  
 Hurley Electronic of Inglewood, Inglewood  
 Inglewood Electronics Sp., Inglewood  
 Manley Electronic Sp., Lancaster  
 Scott Radio Sp., Long Beach  
 Bell Radio Sp., Los Angeles  
 Clarion Shop, Los Angeles  
 Los Angeles Kitz Sup., Los Angeles  
 Figarte Radio Sp., Los Angeles  
 Heathkit Electronic Center, Los Angeles, San Diego

Henry Radio, Los Angeles  
 International Television, Los Angeles  
 Kieruff Electronics, Los Angeles  
 Radio Products Sales, Los Angeles  
 Reeves Electronics, Los Angeles  
 Universal Radio, Los Angeles  
 Pacific Electronic Radio Sp., Modesto  
 Home Distributing Co., North Hollywood  
 Sylmar, Tujunga  
 Brill Electronics, Oakland  
 Elmar Electronics, Oakland  
 Millers Radio & TV Sp., Oakland, Santa Rosa, Walnut Creek  
 Panorama Electronics, Pacoima  
 Eley W. Ley, Paramount  
 Allied Radio, Pasadena  
 Electronic Components, Pasadena  
 Empire Electro Distributors, Pasadena  
 Bay Electronics, Redondo Beach  
 Colverson Sp., Riverside  
 Electronic Sp., Riverside, San Bernardino  
 Mission Hamp Sp., Riverside  
 Norcal Electronics, Sacramento  
 Sacramento Electronic Sp., Sacramento  
 Fortune Electronics, San Carlos, San Francisco

Southland Electronics, San Diego  
 Shanks & Wright, San Diego  
 Southland Electronics, San Diego  
 Western Radio & TV Sup., San Diego  
 EDISCO, San Francisco, San Raphael  
 Pacific Electronic Distributing, San Francisco  
 San Francisco Radio Sp., San Francisco  
 Millers Electronics, San Jose  
 Queenen Industry Electronics, San Jose  
 Channel Radio, Santa Barbara  
 Electronic Kit & Parts Center, Santa Barbara  
 Mobile Radio, Santa Fe Springs  
 Lombardi Electronics, Santa Maria, Ventura

Midway Electronics, Santa Monica  
 Military Electronics, Sealife  
 Sunnysale Electronics, Sunnysale  
 Wholesale Electronic Supply, Ventura

## COLORADO

Dagg Elect. Dist. Corp., Boulder  
 Barstien Appliances, Denver  
 Electronic City Co., Denver  
 Heathkit Elec. Center, Denver  
 Radio Specialists Co., Denver  
 Walker Radio Co., L. B., Denver, Grand Junction, Pueblo, Sterling

## CONNECTICUT

Pilgrim Elec. Co. Inc., The, Danbury  
 Cramer Elect. Inc., Hamden  
 Signal Center Inc., Hartford  
 Modern Electron Sply Inc., Kensington  
 Aikins Electronic Sply., New London  
 Arrow Electronics, Norwalk  
 Bond Radio Sp., Waterbury

## DELAWARE

Almo Radio, Wilmington

## FLORIDA

Del Electronics, Tallahassee  
 Dow Electronics, Tallahassee  
 Goldfarb, Inc., Eau Gallie, Miami, W. Palm Beach  
 Coast Electronics, West Palm Beach  
 East Coast Electronics, Miami  
 Southeast Electronics, Jacksonville  
 Southwestern Wholesale, Miami  
 Thurco Electronics, Bradenton, Clearwater, Cocoa, Daytona Beach, Ft. Lauderdale, Ft. Myers, Ft. Pierce, Gainesville, Homestead, Key West, Jacksonville, Lakeland, Miami, Ocala, Deland, Orlando, Palm Bay, Pensacola, Sarasota, St. Petersburg, Tallahassee, Tampa, West Palm Beach

Hammill Electronics, Daytona Beach, Jacksonville, Lakeland, Orlando, Tampa  
 Electronic Wholesale, Melbourne, Miami  
 Electronic Equipment, Miami  
 Gosper Radio, St. Petersburg  
 Welch Radio, St. Petersburg

## GEORGIA

Southwestern Radio Parts, Albany, Athens, Atlanta, Gainesville, La Grange, Macon, Rome, Savannah  
 Jackson Electronic Sp., Atlanta  
 World Electronics, Atlanta  
 Augusta Wholesale Electronics, Augusta  
 Hamilton Electronic Sp., Augusta  
 Radio Sales & Service, Columbus  
 Curle Radio Sp., Dalton

## HAWAII

American Factors, Ltd., Honolulu  
 Pacific Electronics, Honolulu  
 Precision Radio, Ltd., Honolulu  
 Radio Wholesale & Sp., Honolulu  
 W. A. Ramsey Co., Honolulu  
 Comtel Engineering, Honolulu

## IDAHO

A-Gen Supply Co., Boise, Caldwell  
 Ross, S. H., Inc., Boise  
 Billmore Inc., Pocatello

## ILLINOIS

York Radio, Bloomington, Champaign, Decatur, Kankakee, Springfield  
 Ohio Valley Sound, Centralia  
 Electronic Parts, Champaign  
 Radio Doctors, Champaign  
 Albel Radio Corp., Chicago, Forest Park, Chicago  
 Maywood, Skokie  
 J. C. Bowman & Company, Chicago  
 Cooper, Jr., R., Chicago  
 Electronic Dist. Inc., Chicago  
 Newark Electronics, Chicago  
 Bud Electronic Sp., Danville  
 Aero Electronic Dist., East Chicago  
 Knox Electric Supply Inc., Galesburg  
 Baptist Electronic Sp., Jacksonville  
 Heathkit Electronic Center, Lincolnwood  
 Wabash Electronics, Mt. Carmel  
 Melvin Electronics, Oak Park  
 Crescent Electric Supply Co., Peoria  
 Klaus Radio & Electric Co., Peoria  
 Felkie Electronics, Peoria  
 Yeoman Distributing Co., Peoria  
 Jaytronic, Rockford  
 Melvin Electronics Inc., Rockford  
 Newark Associates, Inc., Rockford  
 Bruce Electronics, Springfield

## INDIANA

Electronic Supply Co., Bedford  
 Stansifer Radio, Bloomington  
 Williams Co., H. A., Bloomington, Columbus, Richmond  
 Hutch & Son, Evansville  
 Ohio Valley Sound, Evansville, Vincennes  
 Wesco Radio Sp., Evansville  
 Brown Electronics Inc., Fort Wayne  
 Penkton Laboratories, Fort Wayne  
 Protective Electrical Supply, Fort Wayne  
 Warren Radio Co., Fort Wayne, Indianapolis

Allied Radio, Gary  
 Cosmopolitan Radio, Gary  
 Electronic Dist. Inc., Indianapolis  
 Graham Electronics, Indianapolis  
 Hoosier Radio Sp., Indianapolis  
 Radio Diag. Co., Indianapolis  
 Georges Electronic Supplies, Kokomo  
 Telson Radio Distn., Kokomo, Logansport, Peru  
 CWY Electronics, Lafayette  
 Madison Electronics, Madison  
 Cedar Rapids Supply, Inc., Marion  
 Tri-State Electric Co., Michigan City  
 Rowfield, Richmond  
 Gofax Co., South Bend  
 C. T. Evinger, Terre Haute  
 Bowman & Associates, Jess, Valparaiso

## IOWA

Mid-State Distributing Co., Ames, Carroll, Cedar Rapids, Des Moines, Granger  
 Des Moines, Iowa City, Marshalltown, Mason City, Okaloosa, Ottumwa, Spencer, Straw Leary Point, Waterloo  
 Crescent Electric Supply Co., Burlington, Davenport, Dubuque, Sioux City  
 Iowa Radio Supply Co., Cedar Rapids  
 Radio Trade Supply Co., Des Moines, Ft. Dodge, Marshalltown  
 York Radio & TV, Ft. Madison  
 Waters Electronic Supply, Mason City  
 Molted Distributing, Sioux City  
 Fagnsworth Electronics, Waterloo

## KANSAS

Norman Electronic Sp., Coffeyville  
 Interstate Electronic Sp., Dodge City  
 Hays, Hutchinson, Topeka, Wichita  
 Electronics Sp., Great Bend  
 Henshaw TV Sp., Kansas City, Mission  
 Acme Radio Sp., Manhattan, Topeka

## KENTUCKY

Crescent Radio Supply, Bowling Green, Somerset  
 Chemistry Electronics, Corbin  
 Arby Electronics, Danville, Louisville  
 Electronics Inc., Lexington  
 Radio Elect. Equipment Co. Inc., Lexington  
 P. I. Burks Co., Louisville  
 Ferriss Elect. Equip. Co., Louisville  
 Universal Electronic Sp., Louisville  
 Ohio Valley Sound, Owensboro  
 Warren Radio, Paducah

## LOUISIANA

Electronic Service Sp., Alexandria  
 Davis Electronic Sp., Baton Rouge  
 Ralphs of Lafayette, Baton Rouge, Lafayette, Lake Charles, Morgan City, New Iberia  
 Eper, Gretna, New Orleans  
 Crescent Electronic Sp., Houma, Metairie, New Orleans  
 Sterling Electronics, Lafayette  
 Graybar Electric, Lake Charles, Shreveport  
 Wholesale Radio Equipment, Lake Charles  
 TV Wholesale Sp., Monroe, W. Monroe  
 Radio Parts, New Orleans  
 Shuler Sp., New Orleans  
 Walker Bros., New Orleans  
 Opelousas Radio Equipment, Opelousas  
 BSS Electronics, Shreveport  
 Koolman Sales, Shreveport

## MAINE

Radio Supply Co. Inc., Auburn, Bangor, Waterville

## MARYLAND

A. R. Spartans Co., Baltimore  
 American Dist. Co., Baltimore  
 Kamm-Elect. Inc., Baltimore  
 Teeves Sply. Co., Brocton, Jamaica  
 Alpheguy Electronics Inc., Cumberland  
 Revaco of Maryland Inc., Glen Burnie  
 Stoddard Supply Co., Hagerstown  
 Lafayette Radio Elect. Mt. Rainier  
 Almo Radio, Salisbury  
 Standard Elect. Supply Co. Inc., Salisbury  
 Baynesville Electronics, Towson

## MASSACHUSETTS

Gerber Radio Sply., Boston  
 Lafayette Radio Corp., Boston  
 O'Donnell Elect. Sply. Co., Boston  
 Teeves Sply. Co., Brocton, Jamaica  
 Plain, Lowell, Peabody  
 Ware Radio Sply., Brockton  
 Electronic Supply Corp., Cambridge  
 Ross Co., E. A., Fall River  
 Aho Electronics Inc., Lawrence  
 Des Roberts, Lynn  
 Lind Electronic Supply, Lynn  
 Durrell Electronics, Medford, Natick, Sattus, Gosh, Waltham  
 Lafayette Ind. Elect., Natick  
 Industrial Elect. Sply. Inc., Needham Heights  
 Cramer Elect. Inc., Newton  
 Green Shaw Co. Inc., Newton  
 Abbott Electronics Co., North Woburn  
 Pilgrim Elect. Sply. Corp., Quincy  
 Cushing Inc., T. F., Springfield  
 Soundco Electronic Sply Co., Springfield  
 Radio Maintenance Sply., Worcester

## MICHIGAN

Purchase Radio Supply, Ann Arbor  
 Electronic Supply Corp., Battle Creek  
 Warren Radio Company, Battle Creek  
 Ferndale, Grand Rapids, Kalamazoo, Owosso  
 Benton Electronic Supply, Benton Harbor  
 Radio Electronic Supply, Cadillac, Detroit, Grand Rapids  
 Straits Dist. Inc., Cheboygan, Sault Ste. Marie  
 Gloufale Elect. Supply Co., Detroit, Lansing  
 Master Elect. Supply Co., Detroit  
 Newark Ferguson Sply. Inc., Detroit  
 Radio Specialties Co., Detroit, Redford, Wyandotte  
 Milson Electronic Sp. Co., Ferndale  
 Lifsey Distributing Co., Flint  
 Taylor Elect. Supply, Flint  
 Elect. Supply of Pontiac, Fort Huron, Port Huron

## MINNESOTA

Northwest Radio, Duluth  
 Stark Electronic Supply Co., Duluth, La Crosse, Minneapolis, St. Cloud, St. Paul

Admiral Apic, Inc., Minneapolis  
 Bonn Co., Lew, Minneapolis, Rochester  
 Electronic Center Co., Minneapolis  
 Radio Electric Supply, Minneapolis  
 Copher Electronics, St. Paul  
 SFTW-KEE-LINE Elect. Corp., St. Paul

## MISSISSIPPI

Pate Electronics, Clarksdale, Tupelo  
 Columbus Electronics, Columbus  
 Parham Electronics, Greenwood  
 Crescen Electronic Sp., Gulfport  
 Ellington Electronic Sp., Jackson  
 May & Jackson Distributors, Jackson  
 Radio & TV Essentials, Laurel  
 TV Wholesale Sp., Natchez

## MISSOURI

Surbekun Electronic Sp., Cape Girardeau  
 York Radio & TV, Hannibal  
 Headless TV Sp., Independence, Kansas City  
 Robertson Electronics, Jefferson City  
 Wholesale TV Supplies, Jefferson City  
 Four Star Radio Sp., Joplin  
 Norman Electronic Sp., Joplin, Springfield  
 Burstein Distrib., Kansas City  
 Manhattan Radio & Equipment, Kansas City  
 Miller Radio, Kansas City  
 Radiolab, Kansas City  
 Acme Radio Sp., St. Joseph  
 Electronic Components for Industry, St. Louis

## NEBRASKA

Radio Equipment, Beatrice, Grand Island, Lincoln, Omaha  
 Central Radio Sp., Hastings  
 Scott Electronic Sp., Lincoln, North Platte  
 Omaha Electronics, Omaha  
 Joelum Radio Supply Inc., Scotts Bluff  
 Tri-State Electronics, Scotts Bluff

## NEVADA

Electronic Distributing Co. of Nev., Reno

## NEW HAMPSHIRE

American Radio Corp., Dover

## NEW JERSEY

Almo Radio, Atlantic City, Camden, Trenton, Vineland  
 Kearns Elect. Products Inc., Atlantic City  
 Gem Electronics, Bayonne, East Brunswick, Newark, Orange, Paramus, Springfield, Teaneck  
 Midstate Radio Supply Co., Berlin  
 Joe's Radio Shop, Bridgeton  
 General Radio Supply, Camden  
 Eastern Radio Corp., Clifton  
 Emco Electronics, Hackensack  
 Nulso, Hackensack, Jersey City, Passaic, Paterson  
 State Elect. Parts Corp., Hanover  
 Leader Electronic Supply, Hillsdale  
 B. J. Electronics, Inc., New Brunswick  
 Lafayette Radio & Elect., Newark, Paramus, Plainfield  
 Aubrey Electronics Supply, Ocean Grove  
 Jersey Electronic Dist., Paterson  
 Wtmal Elect. Corp., Paterson  
 Penn Electronics Pt., Pennsauken, Philadelphia

## NEW MEXICO

Kierloff, Alamogordo, Albuquerque  
 Graybar Electronic Co. Inc., Albuquerque  
 B. J. Electronics, Albuquerque  
 Basco Electronic Supply, Farmington  
 Valley Engineering, Los Alamos  
 Southwestern Elect. Parts, Santa Fe

## NEW YORK

Art Orange Radio, Albany  
 Haverly Electric Co. Inc., Albany  
 Krikerkober Appl. Service, Albany  
 Taylor, Edwin E., Albany  
 Alcorn Radio Supply, Amsterdam  
 Gem Electronics, Bayshore, Bellerose, Bronx, Brooklyn, Farmingdale, Forest Hills, Great Neck, Hicksville, Huntington, Mineola, Mount Vernon, New York, Plainview, St. James, Valley Stream, West Bronx, Yonkers  
 Lafayette Radio & Electronics, Bronx, Brooklyn, Jamaica, New York, Scarsdale, Elmsford  
 Rino Electronics Inc., Bronx  
 Economy Electronics Corp., Brooklyn  
 Electronic Equip., Brooklyn  
 Graham Electronics Dist., Brooklyn  
 Lafayette Radio & Electronics, Brooklyn  
 Laco Electronics, Brooklyn  
 Huron Elect. Supply Co. Inc., Buffalo

# DISTRIBUTOR LISTINGS—CONTINUED

**Manned Electronics, Corona**  
Electronic Supply Corp., Elmhurst  
Eddy Electronics, Elmhurst  
Arrow Electronics, Farmingdale, Mineola,  
New York  
Emerald Electronics, Floral Park  
Allen Electronics Inc., Flushing, L. I.  
Ray Supply Inc., Glens Falls, Plattsburgh  
Norman Radio Distr. Inc., Jamaica, L. I.  
Johnson Radio Co., Jamestown  
Aztec Elect. Dist., Kingston  
Greylock Electronic Dist., Kingston, Pough-  
keepsie

Peerless Radio Corp., Lynbrook  
A&P Elect. Inc., Massachusetts  
Seaway Electronics, Massena  
Certified Elect. Inc., Middletown  
Atlas Electronics Corp., New York  
Bele Distrs. Inc., New York  
Calvert Electronics Inc., New York  
Elect. Parts Dist. Co., New York  
Elect. Tube Sales Inc., New York  
Grand Central Radio, New York  
Harvey Radio, New York  
Metropolitan Supply Co., New York  
Midway Radio & TV, New York  
Milo Electronics Corp., New York  
Terminal Hudson Elect., New York  
Atlas Electronics Inc., Plainfield  
Higgins & Sheer Elect. Dist., Poughkeepsie  
Anchor Elect. Dist. Corp., Richmond Hill  
Hoehster Radio, Rochester  
Alfred Electronics Corp., Rockville Centre  
Rome Electronics, Rome  
Adriacalc Electronics Inc., Schenectady  
Electric City Radio Supply, Schenectady  
Schenectady Elect. Distrs., Schenectady  
B&D Distrib., Staten Island  
L.N.L. Dist. Corp., Spoutnot, L. I.  
Gordon Electronics Inc., Syracuse  
Roberts & O'Brien, Syracuse  
Salma Elect. Supply Co. Inc., Syracuse  
Watertown Elect., Watertown  
Melville Radio, White Plains  
Thruway Elect., White Plains

**NORTH CAROLINA**  
Freck Radio & Sup., Asheville  
Dixie Radio Sup., Charlotte, Gastonia  
World Electronics, Charlotte  
Vickers Electronic Sup., Durham  
Southeastern Radio Sup., Fayetteville,  
Greensboro, Hickory, Jacksonville,  
Kingston, Raleigh, Salisbury, Wil-  
mington, Wilson  
Electronic Wholesalers, Winston-Salem  
Walker-Martin, Charlotte, Raleigh

**NORTH DAKOTA**  
Bristol Distributing Co., Bismarck, Fargo,  
Grand Forks, Minot  
John Iverson Co., Mandan, Minot

**OHIO**  
Akron Electronics Supply Co., Akron  
Main TV Supply Co., Akron  
Olkon Radio Company, Akron  
Sun Radio, Akron  
Warren Radio, Akron, Lima, Toledo  
Sevex, Ashland, Delaware, Fremont,  
Mansfield, Marion, Mt. Vernon, San-  
dusky, Tiffin, Wooster  
Canton Electronics, Canton  
Sommer Electric Co., Canton  
TV Parts, Canton  
Buckeye Elec., Chillicothe, Columbus,  
Lancaster, Newark, Zanesville  
Holub Dist., Cincinnati, Newport  
Highes-Peters, Cincinnati, Columbus  
Myronck, Cincinnati  
Newark-Herringer Elect., Cincinnati

**Broadway Elec. Supply Co., Cleveland**  
Pinner, Cleveland, Lorain, Sandusky  
Seaway Elect., Cleveland  
Gaston Electronics, Inc., Dayton, Fairborn,  
Hamilton  
Rankin & Honser Inc., Dayton  
Spreng Electronics, Dayton, Hamilton,  
Middletown, Piqua  
Smith-Friedman, Dayton  
Euclid Radio Parts Corp., East Cleveland  
United Electronics, East Liverpool  
Luna Radio Parts Co., Findlay, Lima,  
Van Wert  
J&B Electronics, Fremont  
Standard Radio, Springfield  
D&R Radio Supply, Steubenville  
Toledo Radio Specialists, Toledo  
Rena Electronics, Warren  
Glen Elect. Supply Corp., Youngstown  
Ross Radio, Youngstown

**OKLAHOMA**  
Trice Wholesale Electronics, Ardmore, Enid,  
Lawton, McAlester, Muskogee, Okla-  
homa City, Okmulgee, Ponca City,  
Tulsa  
Norman Electronics Sup., Bartlesville  
Bobs Amateur Electronics, Oklahoma City  
John H. Cole, Oklahoma City  
Industrial Electronics, Oklahoma City  
Graxlar Electric, Oklahoma City, Tulsa  
Radio Inc., Oklahoma City, Tulsa  
Oil Capital Electronics, Tulsa  
SSS Radio Sup., Tulsa

**OREGON**  
Ace Electronics Inc., Eugene  
United Radio Supply, Eugene, Medford,  
Portland  
Walker, Verl G., Medford  
Pacific Radio Supply, North Bend  
Round-Up Electronics, Pendleton  
Electra-Tech Inc./Newtronic, Portland  
Johnson Co., Lou, Portland  
Television & Radio Supply, Portland  
Willamette Radio Supply, Salem

**PENNSYLVANIA**  
A. A. Peters, Allentown  
Gem Electronics, Allentown  
Allegheny Electronics Inc., Altoona, John-  
stown  
Television Parts Co., Ambler, Butler,  
New Brighton, New Castle  
Powell Electronic Sales, Bristol  
County Supply Co., Coatesville  
Dunfee Co., J. V., Erie  
Radio Distributing, Harrisburg  
Barco Radio Company, Mc Keesport  
Almo Radio, Norristown, Philadelphia  
A. C. Radio Sply., Philadelphia  
Allied Elec. App. Parts Inc., Philadelphia  
Leotronc Distrs., Philadelphia  
Leotronc Res. Labs., Philadelphia  
Sidney Wagner Elect. Sply., Philadelphia  
Simco Elect., Philadelphia  
Electronic Parts Co., Pittsburgh  
Triangle Electronics Co., Pittsburgh  
Tydings Company, Pittsburgh  
Electronics & TV Dist., Reading  
Consolidated Dist., Scranton  
Pursell, Fred P., Scranton  
University Elect. Co. Inc., Stakes College  
Boston Elect. Dist. Inc., Tarentum  
General Radio & Elect., Wilkes-Barre  
Rosen Electronics, York  
Wholesale Radio Parts, York

**RHODE ISLAND**  
Jalburn Electronic Sply., Pawtucket  
W. H. Edwards, Providence

**SOUTH CAROLINA**  
Dixie Radio Sup., Anderson, Columbia,  
Florence, Greenville, Greenwood,  
Spartanburg, Sumter  
Wholesale Radio Sup., Charleston  
Southeastern Radio Sup., Columbia

**SOUTH DAKOTA**  
Burghardt Radio Supply, Aberdeen, Sioux  
Falls, Watertown, Rapid City  
Electronic Supply Co., Mitchell  
Eba Electronics, Rapid City  
Gourley Dist. Co., Sioux Falls

**TENNESSEE**  
Clark Radio Sup., Bristol, Morristown  
Curie Radio Supply, Chattanooga  
Harpe Electronic Distributors, Chattanooga  
Warren Radio, Dyersburg, Memphis  
Churchy Electronics, Johnson City, Kings-  
port  
Radio Electric Sup., Kingsport  
Roumiant Bros., Knoxville  
W&W Distributing Co., Memphis  
Brant Electric, Nashville  
Crescent Radio Supply, Nashville  
Leetra Distributing, Nashville

**TEXAS**  
F&M Electronic Sup., Abilene, Midland  
Graxlar Electric, Abilene, Arlington,  
Dallas, Fort Worth, Odessa  
Radio Communications Sup., Abilene  
Altronic Sply., Amarillo  
W&W Electronics, Amarillo, Lub-  
bock, Midland  
Beta Electronics, Arlington  
Graxlar Electric, Austin, Beaumont,  
Corpus Christi, San Antonio  
Hargin Austin, Austin  
Texas Electronic Sup., Austin  
Wholesale Electronic Sup., Austin  
Electronic Equipment & Engineering,  
Brownsville, Corpus Christi, Harlingen,  
Houston, Victoria  
Rio Radio Sup., Brownsville, Harlingen,  
McAllen  
Sterling Electronic, Beaumont, Bryan,  
Lufkin, Houston, San Antonio  
Leader Electronic Sup., Corpus Christi  
Wicks Radio Equipment, Corpus Christi  
All State Electronics, Dallas  
Allied Electronics, Dallas  
Con-Supply, Dallas  
Galbreth Wholesale Electronics, Dallas  
Southwest Radio Sup., Dallas  
Trice Wholesale Electronics, Dallas, Ft.  
Worth  
Wholesale Electronic Sup., Dallas, Ft.  
Worth, Sherman, Waco, Wichita Falls  
Wilkinson Bros., Dallas  
Mc Neral Inc., El Paso  
Sunland Supply Co. Inc., El Paso  
Worth Electronics, Ft. Worth  
Electronic Corp. of Texas, Galveston,  
Houston  
Automate Distributing, Houston  
Busacker Electronic Equipment, Houston  
Electronic Component Distributor, Houston  
Gilbert Electronics, Houston  
Bull Electronics, Killen, Temple  
Pan American Electronic Co., Laredo  
B&L Radio & TV Sup., Lubbock  
Digi Radio & TV Sup., Port Arthur  
Gunter Wholesale, San Angelo  
Modera Electronics, San Antonio  
Olsen Radio Sup., San Antonio  
Radio & TV Parts, San Antonio  
Sherman Electronics Sup., San Antonio  
McCollock Wholesale TV Sup., Texarkana

**Electronic Sup., Texas City**  
East Texas Electronics, Tyler  
L&M Sales, Waco  
Goss Radio Sup., Wichita Falls

**UTAH**  
Ballard Supply Co., Ogden  
Tri State Elect. Supply, Ogden  
Alpine Electronic Supply, Provo  
Mansell Supply Co., Salt Lake City  
P Langford Radio Supply, Salt Lake City  
Ross Inc., S.R.C., Salt Lake City

**VERMONT**  
Rutland Elect. Distr., Rutland  
Electronic Sply. Inc., White River Junction

**VIRGINIA**  
Certified Electronics, Alexandria  
Arlington Elect. Inc., Arlington  
Kam-Ebert Elect. Inc., Charlottesville,  
Winchester  
Virginia Radio Supply Co., Charlottesville  
Lann Electronics Inc., Hampton, Norfolk,  
Portsmouth  
Electronic Wholesalers, Harrisonburg  
Electrical Wholesalers Inc., Harrisonburg  
Wulfr Elect., Norfolk  
Electronic Supply Co., Petersburg  
Huber Elect. Supply, Richmond  
Meridian Elect., Richmond

**WASHINGTON**  
C&G Electronics Co., Aberdeen, Brem-  
ton, Centralia, Longview, Olympia,  
Seattle, Tacoma  
Advanced Electronics, Bellingham  
Skapi-Whitcom Elect. Supply, Bellingham,  
Mt. Vernon  
Geiger Radio, W. A., Ellensburg  
Pringle Elect. Supply Inc., Everett  
Columbia Electric Co., Kennewick  
Radio Supply Co., Seattle  
Northwest Electronics, Spokane  
Spokane Elect. Supply, Spokane  
Electra-Tech Inc., Nectronic, Vancouver  
Yakima Wholesale Radio Co., Yakima

**WASHINGTON, D. C.**  
Fairway Elects. Inc.  
Silverline Radio & Elect. Sales  
Sun Parts

**WEST VIRGINIA**  
Bluefield Supply Co., Bluefield  
Meyers Electronics Inc., Bluefield  
Mountain Electronics Co., Charleston,  
Clarksburg  
State Electronics Co., Fairmont  
Electronic Supply Inc., Huntington  
Chemists Electronic, Parkersburg  
General Elect. Distr. Inc., Wheeling

**WISCONSIN**  
Elect. Expeditors Inc., Appleton, Green  
Bay, Milwaukee  
Bushland Radio Specialties, Eau Claire  
Harris Radio, Fond du Lac  
Northern Radio & TV Co., Green Bay  
Thompson Electronics, Janesville  
Kruska Electronics, Koshong  
Acme Radio Supply Co., Milwaukee  
Dyko Distributors Inc., Milwaukee  
Radio Parts Co. Inc., Milwaukee  
Badger Electronic Parts Co., Racine  
Koswell Co., J. J., Sheboygan  
Marshall Radio Supply Co., West Allis

**WYOMING**  
Fleming Supply Inc., Casper  
Garrod Eng. & Supply Inc., Laramie

# GENERAL ELECTRIC



**FREE!** Fill in this coupon and take it to the nearest Authorized G-E Electronic Components Distributor listed above and receive a free edition of G.E.'s new HOBBY MANUAL. General Electric is anxious to provide new components and new ideas for your home electronic workshop. You can help us, and earn your free HOBBY MANUAL, by recommending three new electronic components you could use in your experiments.

(1) \_\_\_\_\_  
(2) \_\_\_\_\_  
(3) \_\_\_\_\_

NAME \_\_\_\_\_  
ADDRESS \_\_\_\_\_  
CITY \_\_\_\_\_ STATE \_\_\_\_\_

(285-11)

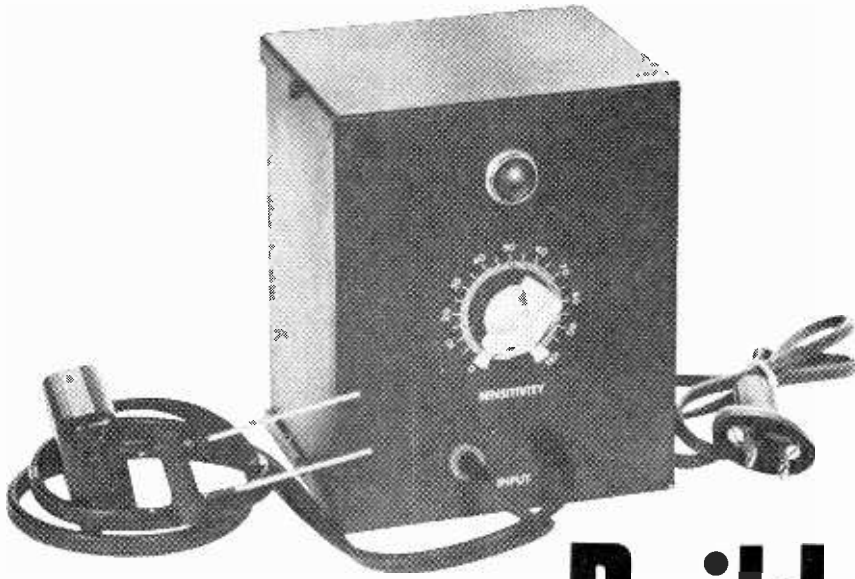

# Build the Multi-Trol

By RYDER WILSON

WHILE ORIGINALLY designed to provide automatic cutoff for a commercial dehumidifier, the "Multi-Trol" has proved so versatile that it has been adapted to a variety of other applications. Electrical appliances that draw up to 800 watts can be turned on or off by a signal as small as 50 microwatts. Cadmium sulphide photocells, thermistors, humidity sensors, or even a carbon microphone can be used to trigger the unit as they respond to variations in light, heat, humidity or sound. When attached to a pair of metal probes in the ground, the Multi-Trol will serve as a soil moisture indicator and can be used to turn on electrically operated valves for automatic watering.

**Circuit Design.** The circuit was designed to provide maximum sensitivity and power handling with a minimum of parts. This is accomplished by using a very high-gain transistor ( $Q1$ ) as a grounded emitter current amplifier to drive a sensitive relay  $K1$  which in turn operates power relay  $K2$ .

The 2N1379 transistor used had a measured d.c. current gain of 220 with a base input of 200 ma. A linear 100,000-ohm potentiometer,  $R3$ , in series with

the base, sensor and supply voltage, controls the sensitivity by limiting the base current. Resistor  $R3$  may be changed to 1 megohm when the resistance across the input terminals is less than 50,000 ohms to give a little better control. Examples of such inputs would be low resistance photocells or humidity sensors.

A small silicon diode,  $D2$ , protects the transistor from transients developed across the coil of relay  $K1$ . Pilot lamp  $I1$  provides a visual indication that the power relay  $K2$  has operated, and this lamp may be replaced by a bell, buzzer, or any other warning device the builder desires.

Operating power is obtained from a



**Use it to control almost any device  
with nearly any signal**

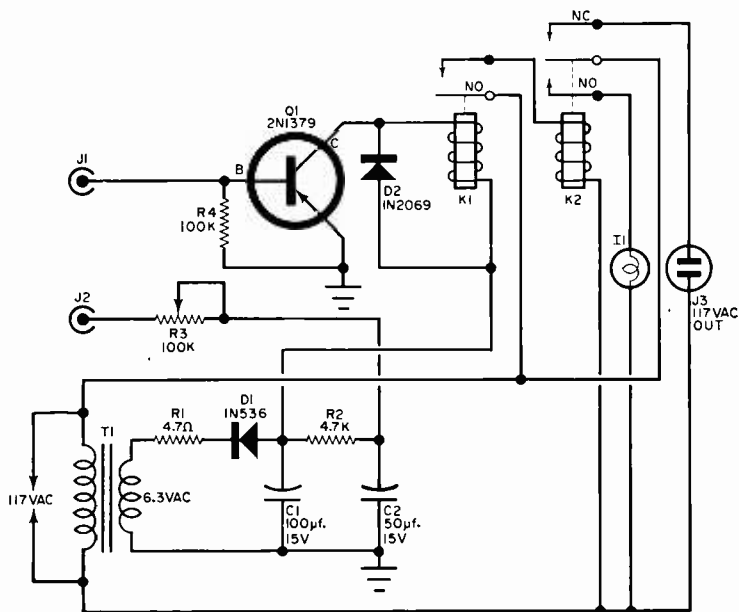

You should have no problems in constructing the Multi-Trol as layout is not at all critical. The "NC" and "NO" designations at relays K1 and K2 refer to "normally closed" and "normally open" terminal points.

**PARTS LIST**

C1—100- $\mu$ f., 15-volt electrolytic capacitor  
 C2—50- $\mu$ f., 15-volt electrolytic capacitor  
 D1—1N536 silicon diode  
 D2—1N2069 silicon diode  
 I1—117-volt, 3-watt pilot lamp  
 J1, J2—Nylon insulated pin jack  
 J3—A.c. connector, female, recessed chassis mounting  
 K1—S.p.d.t., 550-ohm, 9.5-ma. relay (Sigma 11F-550-G/SIL)

K2—S.p.d.t., 115-volt relay (Potter & Brumfield MR5A)  
 Q1—2N1379 transistor  
 R1—4.7-ohm, 1-watt resistor  
 R2—4700-ohm, 1-watt resistor  
 R3—100,000-ohm linear potentiometer  
 R4—100,000-ohm, 1/2-watt resistor  
 T1—Filament transformer; primary, 117 volts; secondary 6.3 volts @ 1 ampere  
 1—4" x 5" x 6" aluminum Minibox

small filament transformer, T1. The transformer output is rectified by diode D1 and filtered by capacitors C1 and C2. This gives approximately 8.5 volts at the collector of Q1.

An appliance plugged into the Multi-Trol can be made normally off instead of on, by reversing the two connections to the normally open and normally closed contacts of relay K2.

**Construction.** The author's unit is built into a 4" x 5" x 6" utility box, but with some ingenuity the parts could be fitted into a smaller enclosure. Parts placement is not at all critical. The dehumidifier probe consists of a pair of No. 10 copper wires mounted in a Bakelite ter-

minal block. This is then encased in a small plastic box and sprayed with plastic to make it waterproof. The two leads from the probe are terminated in pin plugs to conveniently fit jacks J1 and J2.

When the probes are in one inch of water, the resistance across them is approximately 25,000 ohms. Neither the spacing nor the length of the probes is critical; they may be adjusted to suit the builder's convenience.

**Using the Multi-Trol.** Plug your dehumidifier into outlet J3 and place the probe on top of the water bucket so that the two copper wires will be in approximately one inch of water, at the level where the dehumidifier is to be cut off.

## HOW IT WORKS

The appliance to be controlled is plugged into a.c. connector *J3* which supplies its line voltage through the normally closed contacts of relay *K2*. Placing a resistance of about 50,000 ohms, such as a photocell, thermistor, or other resistive sensor, at the input causes a small current to flow in the base circuit of transistor *Q1*. This current is amplified in the collector circuit which actuates sensitive relay *K1*. This in turn supplies the power to relay *K2*. When relay *K2* operates, the a.c. voltage is removed from the load, and applied to indicator lamp *I1*.

Start with 10"-long probes, and cut them to the desired length. Plug the Multi-Trol into the nearest wall outlet, and it is ready to go to work for you.

**Other Applications.** An inexpensive cadmium sulphide photocell (for example,

Lafayette Radio's Stock No. MS 855) can be used to convert the Multi-Trol to a controller for house lamps, photoflood lamps, or other electrical appliances. Connect the photocell to input terminals *J1* and *J2* and adjust the sensitivity control as required.

As an electronic thermostat, the circuit is just as sensitive and as easy to use as in the photocell application. Select a thermistor with a resistance of about 100,000 ohms (such as the Lafayette 51CA1), plug it into *J1-J2*, and set the sensitivity control to trigger the circuit at the selected temperature.

There are many other possible applications for the Multi-Trol. The average builder will enjoy discovering them for himself. —30—

## Loudspeaker Code Practice

**ANY RECEIVER** can easily be converted to a loudspeaker code practice oscillator. By feeding a portion of the output signal to the grid of the first audio stage, a squeal is set up that is heard in the loudspeaker.

Simply hook a pair of capacitors from .0001 to .01  $\mu\text{f.}$  at the points designated "x" in the schematic diagram. Mount a three-circuit (stereo) phone jack on the radio set and solder the open ends of the capacitors to the A and B lugs of the phone jack. Do NOT connect to the ground lug of the jack.

Attach a matching plug to your key, connecting as shown, and plug the key into the jack to practice code. The volume control on the radio will also serve as a volume control for code practice. And you can still use the radio as an ordinary receiver if you remove the key plug from the jack.

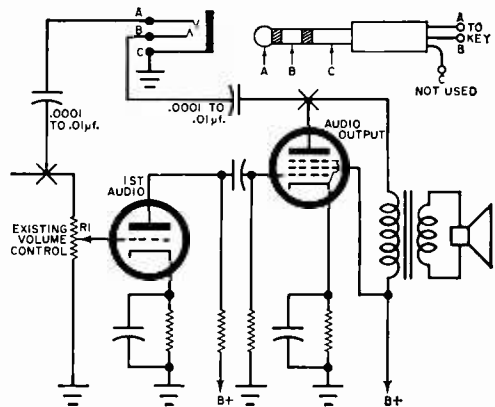

This modified radio code practice oscillator has plenty of pep, and is more than sufficient to sound off for a class full of budding hams.

—Frank A. Parker

## Customize Your Pilot Lamps

**TO GIVE** your equipment that "ultimate touch," add pilot lamps that can be read. Cut small discs from celluloid or plastic, and letter them with such legends as "ON," "OFF," or anything else that is appropriate. Letter the discs with decals, press-on letters, or with India

ink. Most materials will take the ink if you lightly sand them first. In many cases, just one letter or number ("P" for power, "A" for amplifier, etc.) will be sufficient. The completed assembly looks like any pilot lamp—until you turn it on.

—Tim Callan

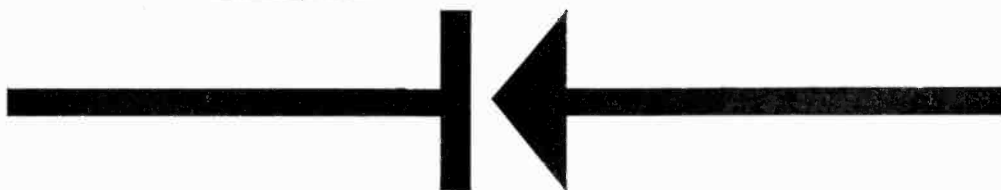
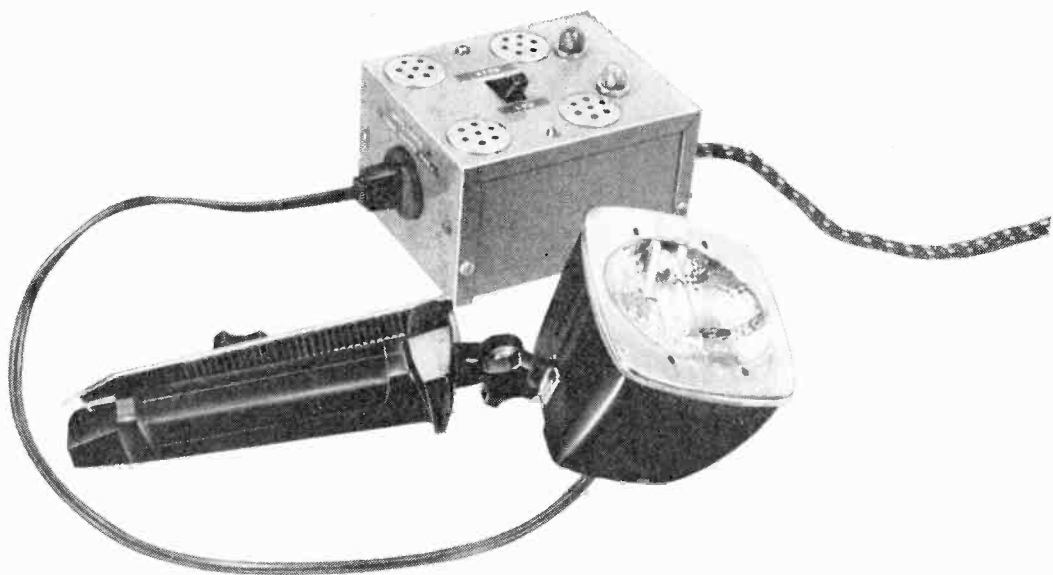

# HIGH WATTAGE REDUCER

**Use low-cost, high-amperage silicon diodes for easy power control**

**T**HIS HANDY PROJECT is a by-product of our space age. Without the impetus to develop high-amperage, solid-state rectifiers necessary for the space program, electronics experimenters would not have been able to buy "over-runs," surplus or seconds. As it is, silicon diode rectifiers with 20-ampere ratings are being offered for about \$3. The multiple household uses for these devices have never been fully explored, so here are a few ideas on how to use them—you'll probably find many more.

As shown above, you can extend the life of your home movie high-intensity lighting equipment. You can halve the output of a 1000-1200 watt electric heater (as long as it does not incorporate a motorized fan), giving you controlled warmth and "reserve" heating power. The same applies to a soldering iron (no guns), or perhaps

your electric cooker (again, no motor). You'll find the "Reducer" inexpensive and easy to build. Best of all, the unit itself consumes no power—it simply saves it.

Construction is simple, requiring only that the heat sink be well insulated from the aluminum box. The author used surplus ceramic bushings about  $\frac{3}{4}$ " high, threaded on both ends. A 20-amp diode will run hot

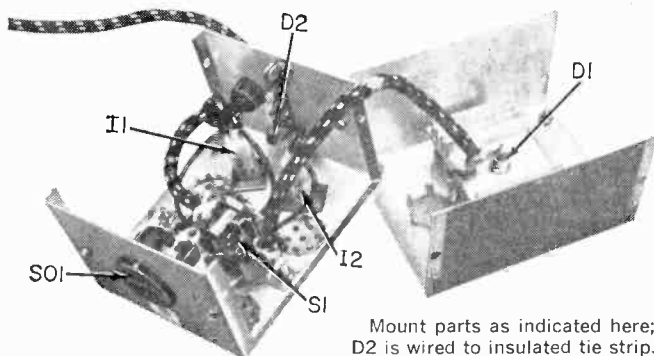

Mount parts as indicated here; D2 is wired to insulated tie strip.

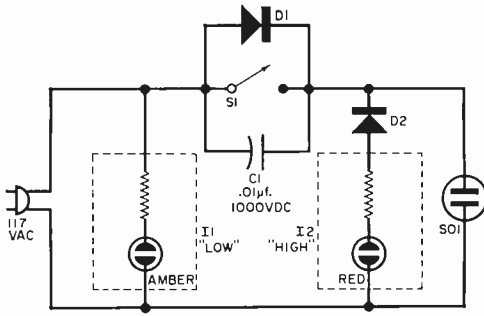
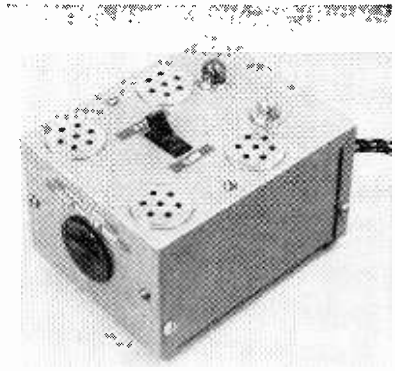

Diagram shows simplicity of High Wattage Reducer.

#### PARTS LIST

- C1*—0.01- $\mu$ f., 1000-volt ceramic disc capacitor  
*D1*—20-ampere, 400 PIV silicon diode, stud mounting  
*D2*—50-ma., 200 PIV silicon diode  
*I1*—Neon lamp assembly with built-in resistor, amber color lens  
*I2*—Neon lamp assembly with built-in resistor, red color lens  
*S1*—S.p.s.t. switch, heavy-duty (15-ampere minimum rating)  
*SO1*—Chassis-mount a.c. socket  
*1*—3" x 4" x 5" Minibox  
*1*—Heat sink (Carl Cordover HSR-4 or equivalent)  
*Misc.*—Four threaded ceramic bushings to hold heat sink, heavy-duty a.c. cord, terminal strip, wire, solder, hardware



In addition to mounting *D1* on heat sink, ventilation holes should be provided to dissipate heat generated in operation.

in series with appliances that have a rated power drain of 1400-1500 watts, so the heat sink is a must—it also makes a convenient mount for the diode.

Holes for ventilation should be punched in the aluminum box as in the photos. Two neon lamps (optional) were incorporated in the circuit to show operation. When switch *S1* is open, *D1* and *D2* are back-to-back, and *I2* will go out. When switch *S1* is closed, both neons go on and the silicon diode is switched out of the "Reducer" circuit.

—Frank A. Parker

## CB Dummy Load

**C**ITIZENS BAND regulations prohibit the practice of tuning up your transmitter while putting a "dead" carrier on the air. The commonly-used light bulb dummy antenna prevents this, but it changes resistance with brightness.

The dummy load shown at right is easily made by soldering a bus bar to the center post of a coax connector and two resistors between the bus bar and the shell. If your CB transmitter uses 52-ohm coax line, make the load of two 100-ohm, 2- or 3-watt resistors. For 72-ohm line, use two 150-ohm, 2- or 3-watt resistors. Be sure that the resistors are carbon and not wire-wound. Wire-wound units will introduce inductance and upset readings.

Tune up with the dummy load using the internal metering in your CB unit or the r.f. probe of a VTVM clipped across the load. A reading of 13-13½ volts corresponds to 3.5 watts output with 52-ohm line.

—Alex F. Burr, 16W2941

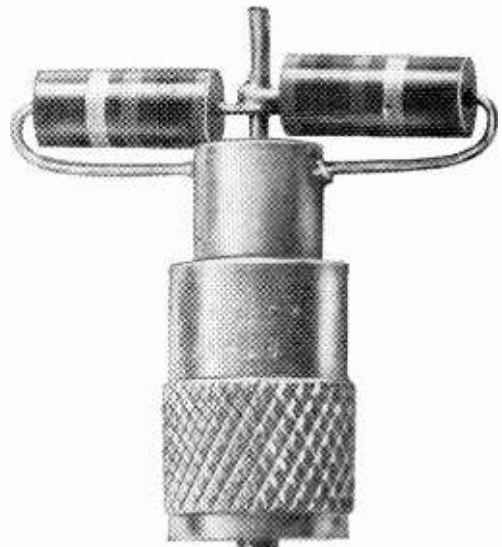

Electronic Experimenter's Handbook

# FREE!



send today for your  
**ALLIED**  
1966 CATALOG

508 VALUE-PACKED PAGES  
world's biggest selection

**SAVE MOST ON:**

*Stereo Hi-Fi  
Tape Recording  
CB 2-Way Radio  
FM-AM & AM Radios  
Portable TV • Phonographs  
Short Wave & Ham Gear  
Automotive Electronics  
Test Instruments  
TV Tubes & Antennas  
Power Tools, Hardware  
Parts, Tubes, Transistors*

**SEND COUPON TODAY!**

**NEW** in the wonderful world of  
**knight-kits®**

See the latest solid-state stereo hi-fi, advanced CB 2-way radios—complete selection of electronic kits for every need, including Hobby, Short-Wave, Amateur, Automotive, Intercom, Test Instrument—wonderfully easy to build.



**EASY TERMS:**

Use the Allied Credit Fund Plan—over 24 months to pay.

*satisfaction guaranteed  
or your money back*

**ALLIED RADIO**  
world's largest electronic supply house

ALLIED RADIO, Dept. 41-K  
100 N. Western Ave., Chicago, Illinois 60680  
 Send FREE 1966 Allied Catalog

Name \_\_\_\_\_  
PLEASE PRINT

Address \_\_\_\_\_

City \_\_\_\_\_ State \_\_\_\_\_ Zip \_\_\_\_\_

CIRCLE NO. 1 ON READER SERVICE CARD

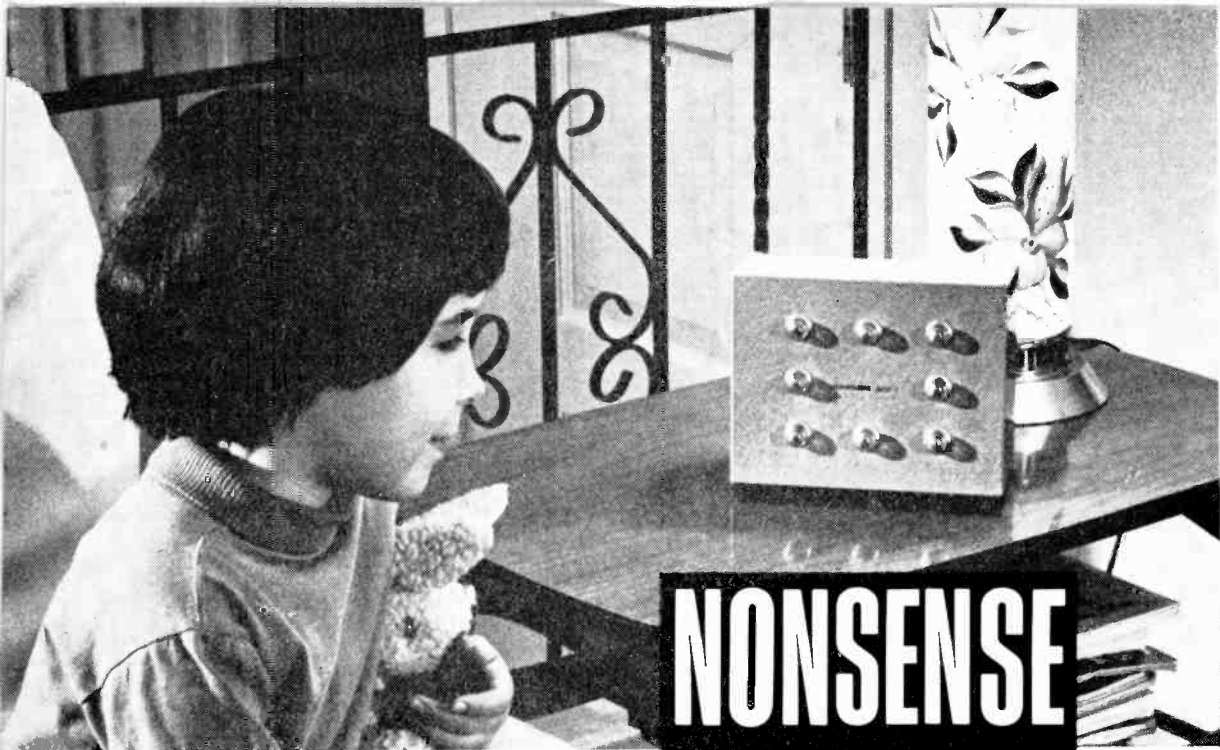

# NONSENSE BOX

*The most useless thing ever published,  
but your children will think it's great*

**YOU MIGHT** tell your kids it's a scintillation counter detecting cosmic messages from outer space. Or, you casually can mention to friends the fact that it's a miniaturized digital computer reading out answers in binary computations. Chances are they'll believe every word you say; only *you* will know that this box is actually "nonsense."

The "Nonsense Box" consists of eight neon lamp flashing circuits flashing at various independent time rates, and all powered by a single 90-volt battery. The current drain imposed by this circuit is around 65 microamperes and the battery should last well over a year. Of course, this is one of the *advantages* (?) of the Nonsense Box—there is no switch to turn it off.

**How It Works.** Each flashing circuit consists of a neon glow lamp, a 0.5- $\mu$ f. 200-volt capacitor and a resistor of one of four specified values from 4.7 to 8.2 megohms. Take a look at the first flashing circuit (*NE1*, *C1*, and *R1*). Since

By **ALAN L. DANZIS**

there is no current flowing in the circuit, there is no voltage drop across *R1*, or resistor *R9* in series with the battery. This permits *NE1* to fire (conduct) setting up a voltage drop across *R1* and charging *C1*. As the charge across *C1* rises, the voltage across the neon bulb drops, and *NE1* is extinguished. Now *C1* slowly discharges through *R1* (the old *R/C* time constant effect) until sufficient voltage builds up across the neon bulb to fire it and cause the whole process to repeat itself.

Even though the flashing circuits are doubled up (*C1/R1* and *C5/R5* have the same values), small capacitor and resistor mismatches insure that no two flashing circuits have the same time constant. Resistor *R9* helps insure the random nature of the firing pattern.

**Construction.** The Nonsense Box can be made of either metal or wood. It

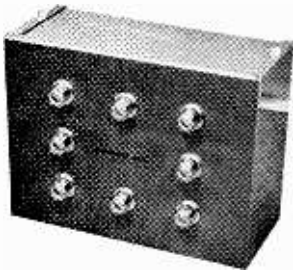
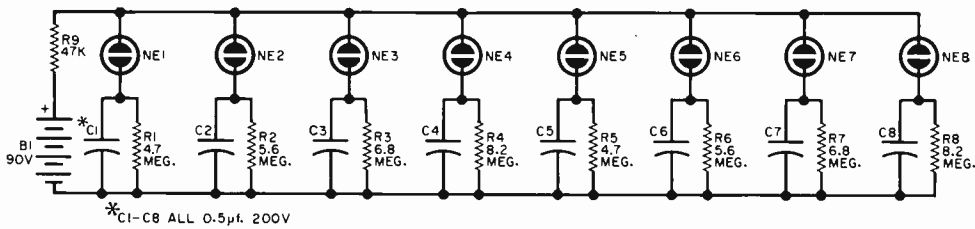

The neon lamps can be arranged in any pattern desired—circle, square, etc.

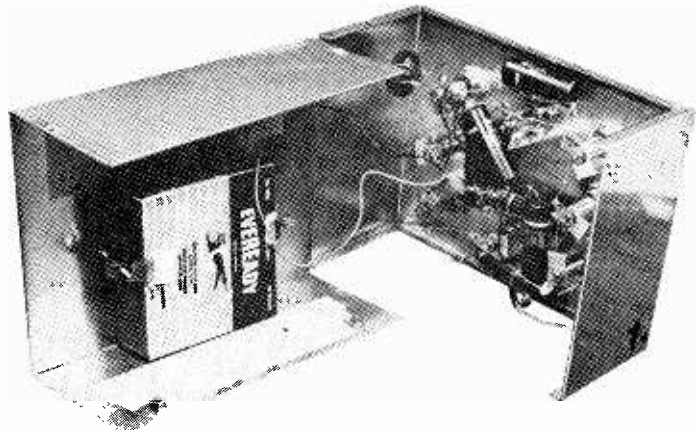

**PARTS LIST**

- B1—90-volt "B" battery (Burgess type V60 or Eveready type 479)
- C1-C8—0.5-µf., 200-volt paper capacitors (eight required)
- NE1-NE8—NE-51 type neon bulb (eight required)
- R1, R5—4.7 megohms
- R2, R6—5.6 megohms
- R3, R7—6.8 megohms
- R4, R8—8.2 megohms
- R9—47,000 ohms
- 8—Neon lamp sockets (Dialco type 810-B with clear plastic lens)
- Misc.—Mounting box, battery retaining clamp, wire, solder, etc.

} All resistors  
} 1/2-watt

should have sufficient space inside to comfortably hold the neon bulb sockets and permit the battery to be mounted rigidly in place. The latter measure is especially necessary since many people will try to shake the Nonsense Box to make it turn off.

Care should be exercised in laying out the holes for mounting the neon lamps. The spacing is not critical, but uniformity is desirable. The lamps could be arranged to make a person's initial, or

The interior wiring of the Nonsense Box can be as haphazard as you want. Be sure to clamp the battery in place to prevent it being shaken loose.

in the square fashion shown in the photos.

Wiring is noncritical—even the battery polarity may be reversed. It is suggested that one terminal of each of the eight lamp sockets be wired together. Solder one end of R9 to this common connection and leave the other end temporarily free. Now solder one end of resistors R1-R8 and capacitors C1-C8 to each of the unused lamp socket terminals according to the wiring schematic. Bring all 16 free leads from these capacitors and resistors to a common bus bar and solder. The two leads from the battery connect to the free end of R9 and the common bus bar.

The Nonsense Box should start flashing immediately—and only you will know that it's all "nonsense." -50-





## Zip through Scott's new solid state FM stereo tuner kit in one afternoon

Four to six hours! That's all you need to zip through Scott's new LT-112 FM stereo tuner kit. Start after lunch—enjoy superb stereo at dinner.

Scott solid state circuitry is the key to the LT-112's superior performance. Costly silicon transistors give performance unapproached by any other kit on the market. The LT-112 is kit-brother to Scott's best-selling 312 solid state stereo tuner, of which *Audio* said, "... one of the finest tuners anywhere."

Your LT-112 arrives with all critical circuitry pre-wired, pre-tested, pre-aligned, and mounted on heavy-duty printed circuit boards. Scott's ex-

clusive life-size, full-color construction book details every step . . . makes perfect wiring almost automatic.

You'd never believe a kit so easy to build could be so packed with features. Built into the LT-112 is a new Scott invention . . . the Tri-modulation meter, used for a Signal Strength Indicator, Zero Center Indicator, and Alignment Meter.

See your Scott dealer today, and pick up an LT-112 tuner kit . . . \$179.95 plus one enjoyable afternoon will net you a lifetime of listening pleasure.

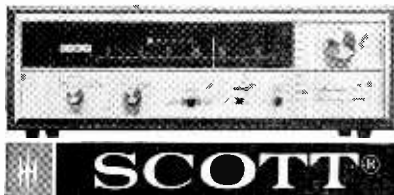

For complete information on Scott's kits & components write: Dept. 521-ID, 4. H. Scott, Inc., 111 Powdermill Road, Maynard, Mass.

Export: Scott International, Maynard, Mass. Cable HIFI. Prices slightly higher west of Rockies.

Prices and specifications subject to change without notice.

**CIRCLE NO. 27 ON READER SERVICE CARD**

# CHAPTER

## 2 AUDIO STEREO HI-FI PROJECTS

*If you are one of those electronics experimenters who think that audio/hi-fi/stereo construction is a thing of the past, you'll be surprised at the content of this chapter. The kickoff project is a novel speaker enclosure embracing an unusual principle called "bi-coupling." Constructed by well-known enclosure designer, David Weems, the "Bi-Coupler" (page 40) is a modified labyrinth using 8" full-range speakers. Builders of the "Bi-Coupler" will be pleasantly surprised by the smooth sound and stereo effectiveness. Next project in line is the "Stereo S'Lector" (page 44)—a convenience for those who like automation in their FM listening.*

*The "Vibrato Simulator" and "Volume Expander" are also projects that can be classified as "unusual." The "Simulator" (page 47) will appeal to budding musicians who have a guitar, and the "Expander" (page 51) is a device for the serious audiophile. The latter can be used monophonically as well as in the featured stereo version.*

*Shutting your hi-fi off with the record player is not new, but the ideas presented on page 58 sure are. You'll admire the versatility of the "Hi-Fi Interlock" and the safety features it incorporates. Last but not least is the "Shotgun Sound Snooper" (page 61). This highly directional microphone has created considerable interest and the designers have completely revised the story to include answers to many questions raised by readers of POPULAR ELECTRONICS.*

40	FOR BETTER SOUND BUILD THE BI-COUPLER .....	David B. Weems
44	THE STEREO S'LECTOR .....	Alton B. Otis, Jr.
47	VIBRATO SIMULATOR .....	Fred Ippolito, Jr.
51	HI-FI VOLUME COMPRESSOR EXPANDER .....	Roger H. Russell
58	HI-FI INTERLOCK .....	Charles L. Ulrick
61	SHOTGUN SOUND SNOOPER .....	James R. Hollinger & John E. Mulligan, K3TIB

# For Better Sound

*Great for either stereo or mono listening, this*

By **DAVID B. WEEMS**

**H**ERE is a versatile, labyrinth speaker system that gives you an almost unlimited choice of speakers because matching them to the enclosure is not critical. This is a real virtue if you decide to switch to a transistorized stereo system and want to make a speaker change. Or, at a later date, you may want to upgrade your speakers or change simply for the sake of change—you can go right ahead and do so, and keep the "Bi-Coupler" enclosure. The only limitation is that you will have to stick to 8" speakers, and, we hope, good ones.

Stereo? One Bi-Coupler can certainly be used as a complete stereo system. The sound will be very satisfactory—quite realistic in fact, since that old "hole in the middle" is nicely filled. While you may ultimately want to add another Bi-Coupler in the interests of greater channel separation, one will serve until you're ready to do so.



# Build the Bi-Coupler

**flexible little system features two full-range speakers**

**Theory.** The labyrinth type enclosures have other virtues but they seem to have fallen by the wayside, although some manufacturers used them for years. The Bi-Coupler is a modified labyrinth with some special features. First, as you might guess from the name, it is compartmentalized. The benefits of multiple full-range speakers are well known, but when more than one such speaker is mounted in a single compartment, there is no guarantee that optimum results will be obtained.

The phase relationship of sound waves on a single baffle gets pretty confusing with more than one speaker, particularly behind the speakers where reflections play an important role. Instead of mutual coupling, the result is likely to be mutual cancellation at some frequencies. The

midrib in this enclosure separates the speakers, insuring that they are in phase on the rear wave, which produces bass reinforcement.

Good high frequency dispersion is obtained from the angled baffles, which also reduce midrange peaks due to reflections from the rear walls. A less obvious advantage to treble reproduction is contributed by the outside shape of the enclosure. A cabinet with corner angles greater than  $90^\circ$  theoretically reduces diffraction effects which, again, are a source of phase distortion and can-

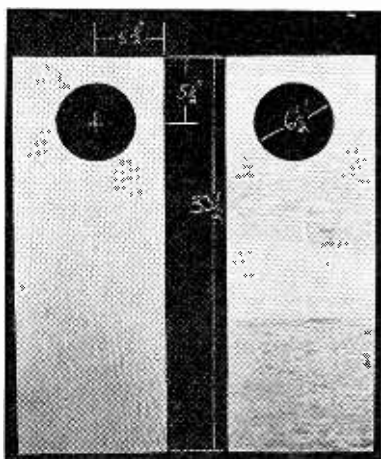

The basic parts of the Bi-Coupler are shown in these photos along with their dimensions. The two front pieces, above, are each  $12\frac{1}{2}'' \times 33\frac{1}{2}''$ ; note spacing and diameter of speaker cutouts. At right, above, is the rear partition and one of the two sides; the diagonal cutouts in the partition create labyrinth effect. Directly at right is the top, bottom, and the midrib. All parts (including a cabinet back if desired) are cut from a single sheet of  $4' \times 8' \times \frac{1}{2}''$  plywood.

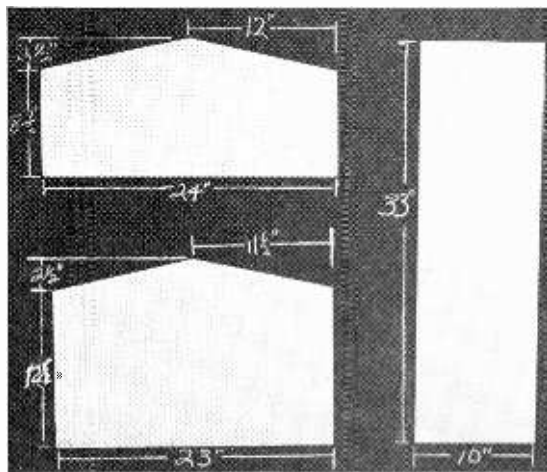
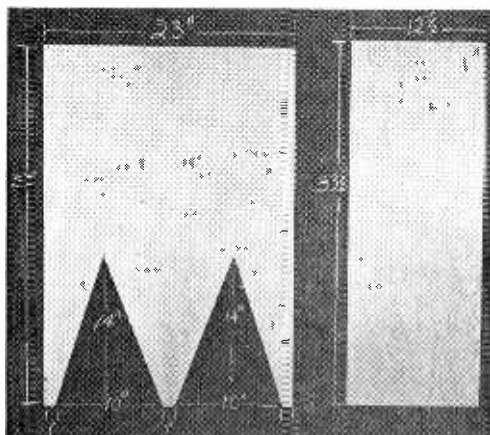

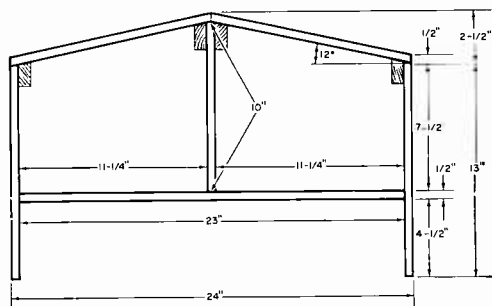
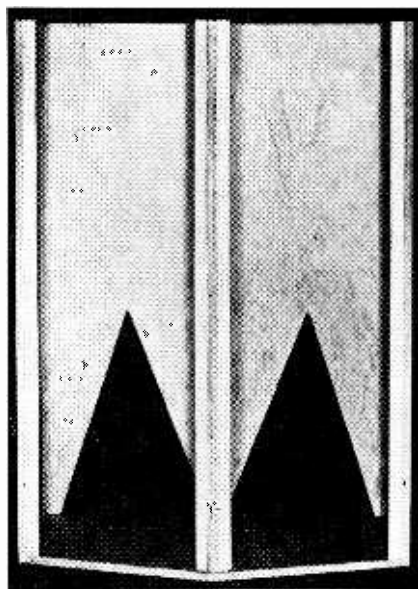

Diagram of the top of the Bi-Coupler's enclosure shows how it is assembled. The front edges of each side, those of the four cleats, and both edges of the front baffles are cut to a 78-degree angle.

Photo at right shows the rear partition, the sides, midrib, and four long cleats mounted to the bottom.



cellation. Finally, the front of the enclosure approximates the same shape a sound wave assumes when it is emitted from a point source, an aid in coupling the speakers to the air.

Panel vibration should be avoided in any type of enclosure. In this case, the specified  $\frac{1}{2}$ " plywood is adequate because an open "pipe" is subject to less pressure build-up than a "box," and also because the panels are narrow and well braced. You may question the advisability of using  $\frac{1}{2}$ " material for the midrib which is subject to stress produced by both speakers. Reconsider. The speakers are mounted symmetrically with regard to that panel, which means that if they are connected in phase the change in pressure from one speaker should exactly cancel the change in pressure from the other speaker! It's an imperfect world, but that was the plan.

**Bi-Coupler Construction.** The parts for the enclosure can be cut from a single 4' x 8' sheet of plywood with enough left over to make a back if desired. The back was not needed for the author's version because the sides fit tightly against the walls of the room in which it is installed. By placing the cabinet on its back on a rug, you can quickly compare the possibilities—complete or backless.

The sides and front pieces of the enclosure are first cut to a width of  $12\frac{1}{2}$ ", but the front edge of each side is then

cut or planed to an angle of  $78^\circ$  as shown in the illustrations. The 1" x 2" cleats should also be cut to this angle. If a power saw is used, set the saw blade at  $12^\circ$ , since  $0^\circ$  gives a cut of  $90^\circ$ . Both edges of the front baffles are later cut at the same angle.

**Assembling the Cabinet.** For a solid job, use glue, screws, and nails. First, glue and nail the 1" x 2" cleats to the midrib, then glue and nail the midrib on a line down the center of the partition (the section with the diagonal cutouts), adding screws when it's in position. Glue and nail the bottom to the partition and midrib. The 1" x 2" cleats can now be glued and screwed to the sides; glue and screw the sides to the bottom and rear partition.

Speaker holes should be cut in each front baffle and then the angled cuts made at the baffle edges. It may be necessary to take off a small amount at each edge to secure a proper fit for these parts. When fitted, glue and screw the front baffles in place. Then locate the speaker mounting bolts, which can temporarily be secured with glue.

The next step is to place the top in position. By reaching in through the speaker holes, an outline of the sides, "fronts," midrib, and partition can be marked under the top with a pencil. The short cleats can be glued and screwed to the underside of the top in the prop-

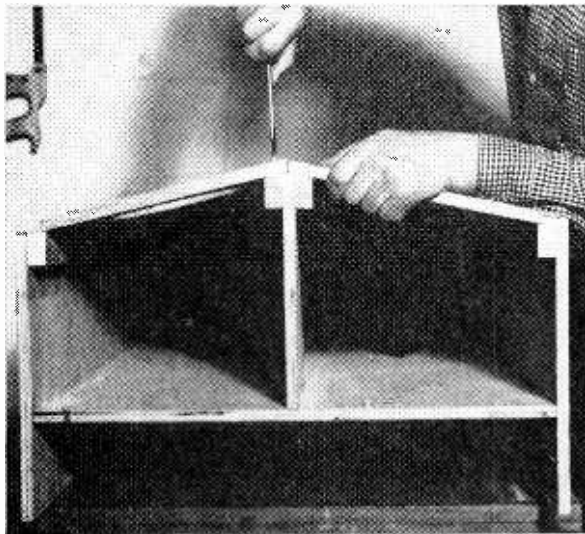

Nails, glue, and screws are used to tightly bond the parts of the enclosure together, and eliminate vibration.

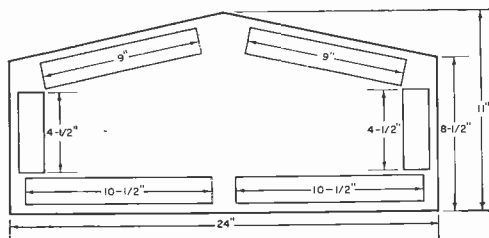
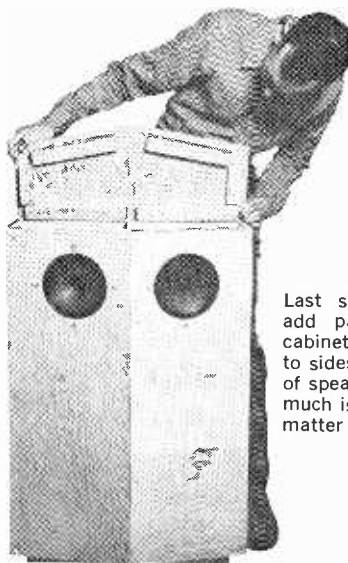

Diagram above shows placement of top cleats; these are positioned  $\frac{1}{2}$ " from edges.



Last step is to add padding in cabinet top, and to sides and rear of speakers. How much is mostly a matter of taste.

Terminals permit the speakers to be connected in series, parallel, or separately.

#### BILL OF MATERIALS

Cut from one 4' x 8' x  $\frac{1}{2}$ " plywood sheet:  
 4— $12\frac{1}{2}$ " x  $33\frac{1}{2}$ " pieces for sides and fronts  
 1—10" x 33" piece for midrib  
 1—23" x 33" piece for rear partition  
 1—11" x 24" piece (less cut-offs) for top  
 1—15" x 23" piece (less cut-offs) for bottom

Cut from 1" x 2" lumber (actual material size approx.  $\frac{3}{4}$ " x  $1\frac{1}{2}$ "):  
 4—33" pieces for front and side cleats  
 2— $10\frac{1}{2}$ " pieces for top cleats  
 2—9" pieces for top cleats  
 2— $4\frac{1}{2}$ " pieces for top cleats  
 1—21" piece for foot (optional)  
 2— $10\frac{1}{2}$ " pieces for foot (optional)

Misc.—Four dozen #6 x  $1\frac{1}{2}$ " screws, 6-d box nails, glue, eight  $\frac{3}{16}$ " x  $1\frac{1}{2}$ " bolts for speakers, grille cloth

er position to receive screws from the outside of the cabinet.

It is a convenience to have an outside connection for each speaker post. In the prototype, this was done by drilling holes in the rear partition and running wires from the speaker terminals to bolts on the back. Thus, the speakers can be connected in series, parallel, or to separate circuits as desired without tearing into the cabinet. When the speakers are mounted, a test should be run to determine how much padding is necessary.

(Continued on page 147)

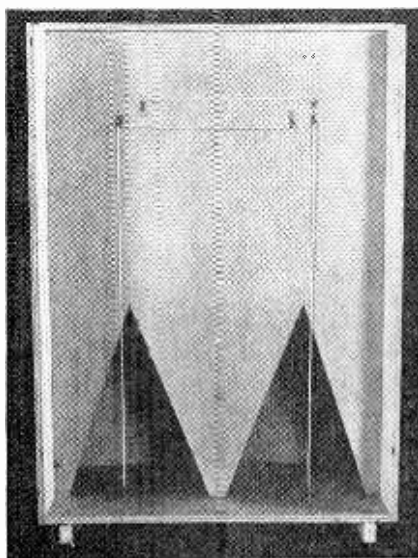

# THE Stereo S'Lector

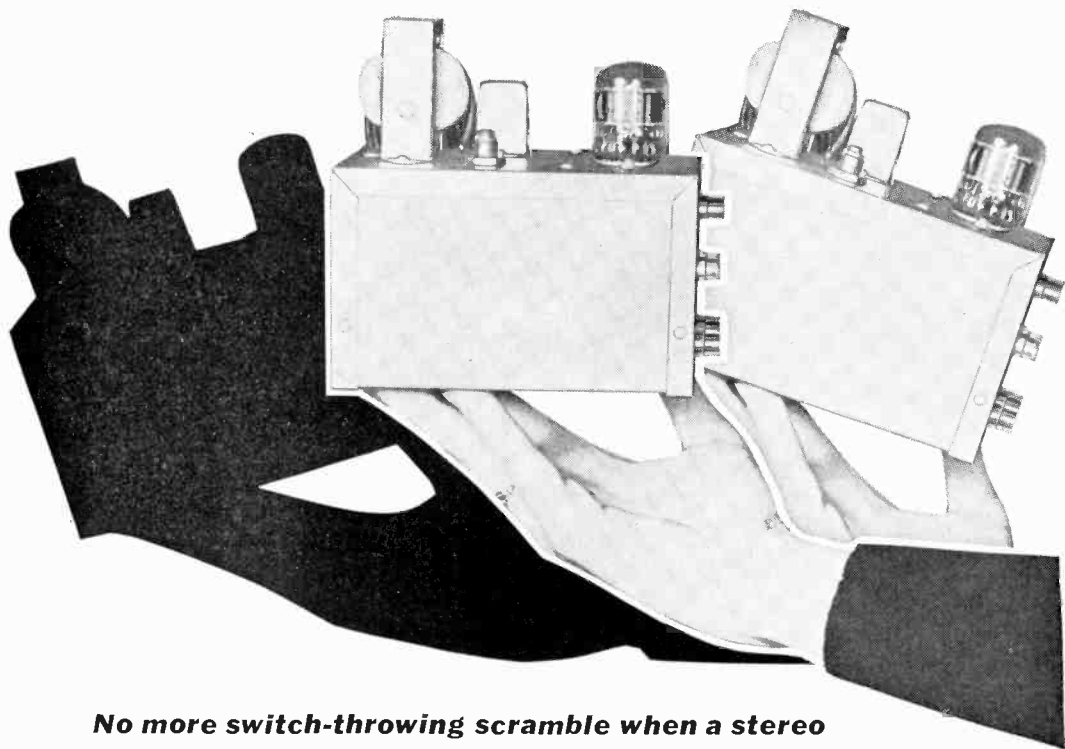

**No more switch-throwing scramble when a stereo station comes in! The S'Lector does it for you**

By ALTON B. OTIS, JR.

**I**F you have a mono FM tuner and an outboard multiplex adapter, the "Stereo S'Lector" is for you! In addition to giving you a visual indication that a stereocast is coming through, it will automatically switch the multiplex adapter into the circuit and connect the adapter's output to the stereo tuner terminals of the amplifier—a feature found only in the more expensive commercial FM stereo tuners. The cost of the parts required to build the S'Lector is nominal—only about \$15.00.

**How it Works.** The single compactron tube, *V1*, is a 6D10 which has three separate triodes in one envelope. The multiplex signal from the tuner is applied to

*V1a*, which is a low-gain amplifier with a high input impedance. From there, it goes to a variable-mu, high-gain amplifier, *V1b*. The output of *V1b* is fed to a filter consisting of *L1* and *C5*. This removes all but the 19-kc. components of the signal.

The 19-kc. signal is rectified by diode *D1* and the resulting d.c. voltage is applied to the grid of relay control *V1c*. When no 19-kc. signal is present (as in a monophonic signal), the relay remains pulled in, connecting the normal output of the tuner to the amplifier. A 19-kc. signal will apply a negative voltage to the grid of *V1c*, which causes the relay to open, connecting the tuner stereo out-



Finish the Stereo S'Lector with a coat of spray paint and press-on letters for jack identification.

put to the amplifier, and simultaneously turning on the stereo indicator lamp (11).

**Building the Unit.** The Stereo S'Lector is constructed in a 3" x 4" x 5" aluminum Minibox. Parts layout is not critical, but the photos show the layout used satisfactorily by the author.

Coil *L1* is mounted by means of a flange provided with the coil. Power rectifier *D2* is mounted on a three-lug (center ground) terminal strip which is attached under one of the power transformer mounting screws. A single solder lug under the other transformer mounting screw serves as a ground for capacitors *C6* and *C7*. Capacitor *C5* mounts directly across the terminals of *L1*, and *D1* is connected directly between *L1* and *R9*.

Two of the four poles of relay *K1* are used for switching the output between the tuner and multiplex adapter. The other two relay poles can be used to trigger external indicators (as shown here) or for other signaling or switching functions.

**Tuning Up.** Check the unit carefully for short circuits, and remove all solder splashes and wire bits. Before installing the 6D10, plug the unit in; the voltage

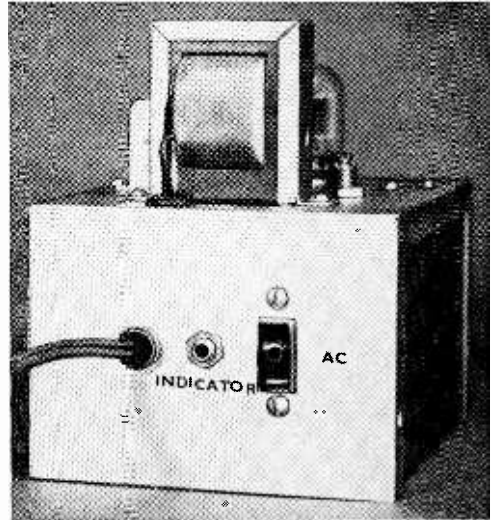
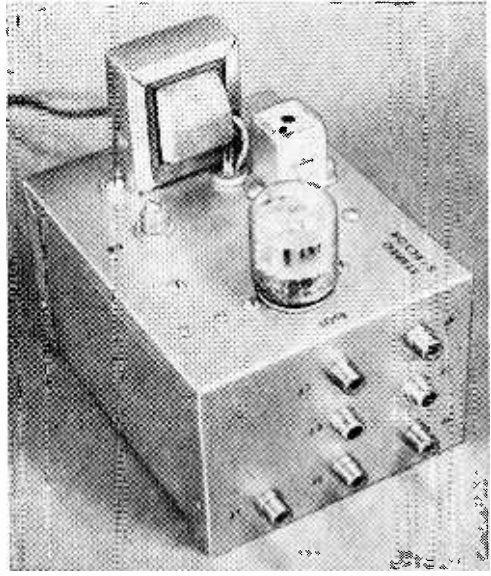

Indicator lamp jack is connected to miniature plug so lamp can be mounted at tuner or amplifier panel.

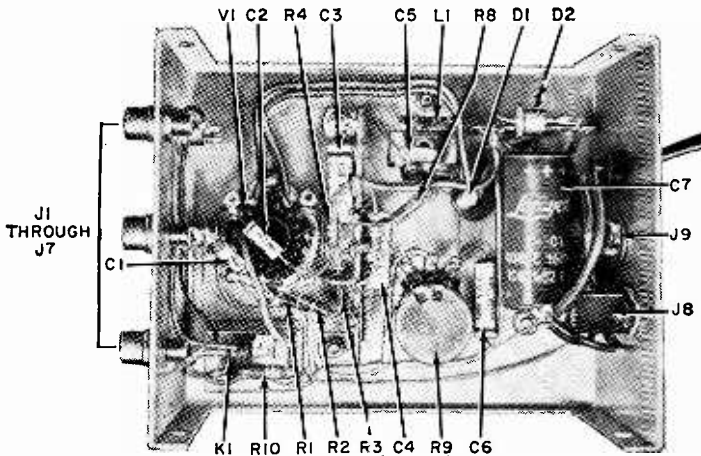

Parts layout is not at all critical but author's model is detailed in photo at left with parts call-outs.

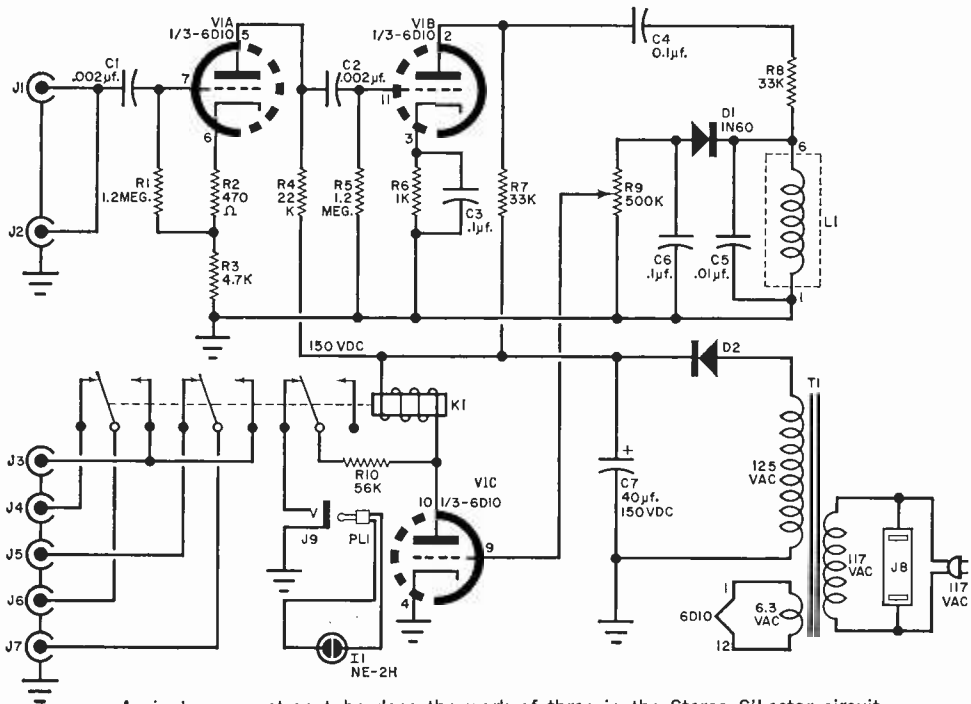

A single compactron tube does the work of three in the Stereo S'Lector circuit.

#### PARTS LIST

- |   |  |
|---|--|
| <p><i>C1, C2—0.002-μf., 200-volt Mylar capacitor</i><br/> <i>C3, C4, C6—0.1-μf., 100-volt Mylar capacitor</i><br/> <i>C5—0.01-μf. ceramic disc capacitor</i><br/> <i>C7—40-μf., 150-volt electrolytic capacitor</i><br/> <i>D1—1N60 diode (or equivalent)</i><br/> <i>D2—50-ma., 400-PIV silicon rectifier</i><br/> <i>I1—NE-2H neon lamp</i><br/> <i>J1-J7—Phono jack (single-hole type)</i><br/> <i>J8—117-volt accessory outlet</i><br/> <i>J9—Miniature phone jack</i><br/> <i>K1—4-p.d.t. relay, 5300-ohm coil, 6.6-ma. pull-in (Lafayettec 99-G-6094 or equivalent)</i><br/> <i>L1—19-kc. oscillator coil (J. W. Miller 1354)</i><br/> <i>PL1—Miniature phone plug</i><br/> <i>R1, R5—1.2-megohm, ½-watt resistor</i></p> | <p><i>R2—470-ohm, ½-watt resistor</i><br/> <i>R3—4700-ohm, ½-watt resistor</i><br/> <i>R4—22,000-ohm, ½-watt resistor</i><br/> <i>R6—1000-ohm, ½-watt resistor</i><br/> <i>R7, R8—33,000-ohm, ½-watt resistor</i><br/> <i>R9—500,000-ohm linear taper potentiometer</i><br/> <i>R10—56,000-ohm, ½-watt resistor</i><br/> <i>T1—Power transformer; primary, 117 volts; secondaries, 125 volts, 15 ma., and 6.3 volts, 0.6-amps. (Lafayettec 33-G-3405, Stancor PS-8415, or equivalent)</i><br/> <i>V1—6D10 compactron tube</i><br/> <i>1—3" x 4" x 5" aluminum Minibox</i><br/> <i>Misc.—12-pin compactron socket, terminal strips, wire, solder, line cord, etc.</i></p> |
|---|--|

across capacitor *C7* should read about 200 volts. Install the tube and allow a short warm-up period. Voltage across *C7* should now read about 140-150 volts, d.c. If it is substantially lower, pull the plug and inspect the unit again for shorts.

Connect the Stereo S'Lector to the tuner with jacks, as follows: *J1* to multiplex output of tuner; *J2* to input of multiplex adapter; *J3* to monophonic output of tuner; *J6* and *J7* to the stereo amplifier inputs; *J4* and *J5* to the output of the multiplex adapter.

With the tuner set to a strong stereo station, adjust the slug in *L1* for maxi-

mum a.c. voltage across the coil. The reading may fluctuate at this point, depending on the program material. Starting with the wiper of *R9* at the ground end, advance the wiper toward *D1* until the relay drops out, then about five or ten degrees more. The unit is now adjusted and ready for use.

The model built by the author has performed very reliably, never confusing interchannel noise and a stereo broadcast. If you build the S'Lector, you'll find it a valuable adjunct to your stereo system, one that you will wonder how you ever got along without. —50—



# VIBRATO SIMULATOR

By FRED IPPOLITO, Jr.

*Low-cost transistorized  
circuit is inserted  
between guitar and  
amplifier. Player controls  
simulator with  
homemade foot switch*

**T**HIS article describes the construction of a simple, low-cost, transistorized vibrato simulator which can provide most musical instrument amplifiers with a vibrato effect. When used in conjunction with a guitar and amplifier, it produces a pleasant-sounding amplitude-modulated signal, similar to the effect of varying the volume control on the guitar.

The vibrato simulator is battery-operated and completely self-contained. No external power source is required and no circuit modifications to the amplifier are necessary. Installation of the simulator consists of plugging it into the amplifier and plugging the instrument into the simulator. The current drain on the battery is so low that in normal use the life of the battery should approach its shelf life. Construction costs are small, less than \$10, even when all the parts are purchased. But you will probably have some of the parts available, reducing the cost even further.

Two controls are provided; one for adjusting the desired intensity and the other for adjusting the vibrato speed. A foot switch is also provided so that the musician can switch the vibrato effect in or out while playing.

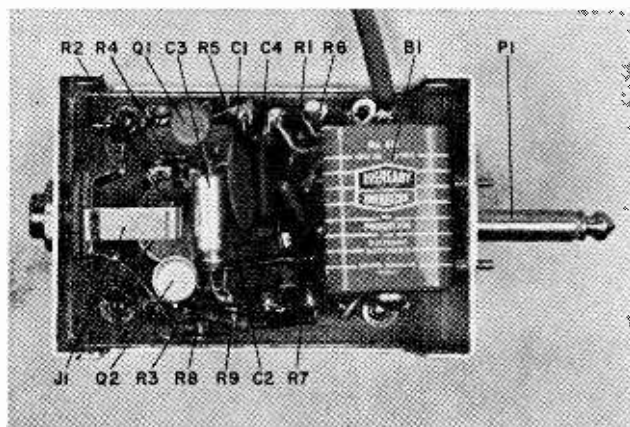

Underside view of the simulator shows compact, sturdy construction used by the author. All connections are made to the potentiometer terminals or to one of the 66-terminal tie strips mounted at either end of the box.

With the self-contained battery, the author wired the simulator so it would always be off unless momentary d.p.s.t. switch *S1* was closed. The guitarist slips this switch on its doorstop mount under his right or left foot.

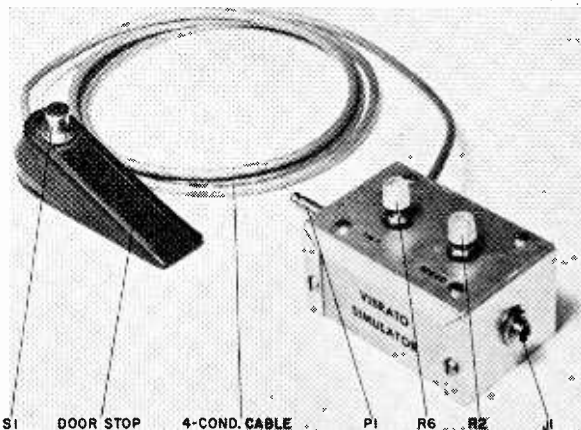

**About the Circuit.** Transistor *Q1* is used in a sub-audio phase-shift oscillator circuit to produce the vibrato speed or frequency. Transistor *Q2* is used in a voltage-divider network to modulate the incoming signal. The effectiveness and efficiency of the vibrato oscillator is remarkable. Using a 15-volt battery, the sine-wave output signal at the collector is 8 volts peak-to-peak, with a current drain on the battery of only 300  $\mu$ a.

Common, low-cost transistors can be used. In testing the circuit, the writer tried at least ten 2N1265/5 transistors, with each providing satisfactory results. Although a 15-volt battery is used to provide sufficient output for this application, the circuit will oscillate with a voltage of 9 to 12 volts.

The oscillator operates at a frequency of 6 cycles, since this is the most commonly used frequency in commercially available units and in electronic organs. Potentiometer *R2* provides for an oscillator range of approximately 4 to 14 cycles. Resistor *R4* prevents oscillator cutoff at the maximum clockwise rotation of *R2*, which is the fastest speed.

Capacitor *C4* couples the oscillator signal to potentiometer *R6*, which is used to adjust the vibrato intensity. Switch *S1* is a momentary d.p.s.t. (normally open) type, used to make and break both the oscillator and modulator circuits. It is mounted in a molded plastic door stop and is used as a foot switch so that the vibrato effect can be switched in and out.

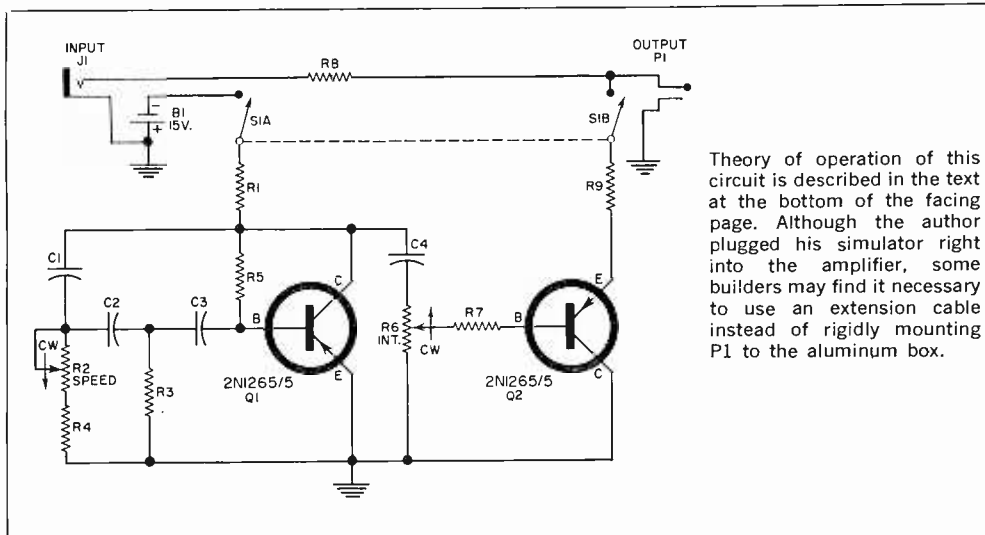

Theory of operation of this circuit is described in the text at the bottom of the facing page. Although the author plugged his simulator right into the amplifier, some builders may find it necessary to use an extension cable instead of rigidly mounting P1 to the aluminum box.

### PARTS LIST

- B1—15-volt battery (Eveready 411 or equivalent)
- C1—0.5- $\mu$ f. capacitor—see text
- C2—1.5- $\mu$ f. capacitor—see text
- C3—5- $\mu$ f. capacitor—see text
- C4—0.05- $\mu$ f. ceramic disc capacitor
- J1—Phone jack (Switchcraft L-11 or equivalent)
- P1—Flat-type phone plug (Switchcraft 220 or equivalent)
- Q1, Q2—2N1265/5 transistor (Sylvania)
- R1—30,000-ohm  $\frac{1}{2}$ -watt resistor
- R2—10,000-ohm potentiometer (Philmore PC-51 or equivalent)
- R3—3300-ohm,  $\frac{1}{2}$ -watt resistor
- R4—3000-ohm,  $\frac{1}{2}$ -watt resistor
- R5—620,000-ohm,  $\frac{1}{2}$ -watt resistor
- R6—500,000-ohm potentiometer (Philmore PC-54 or equivalent)
- R7—470,000-ohm,  $\frac{1}{2}$ -watt resistor
- R8, R9—100,000-ohm,  $\frac{1}{2}$ -watt resistor
- S1—1-p.s.t. momentary push-button switch (normally open)
- 1—3 $\frac{1}{4}$ " x 2 $\frac{1}{8}$ " x 1 $\frac{3}{8}$ " chassis (Bud CU-3001A or equivalent)
- 1—3-foot, 4-conductor shielded cable (Belden 8434 or equivalent)
- 1—Molded plastic door stop—see text

The output signal appearing at P1 is fed to the instrument amplifier and will vary in amplitude at a rate equal to the oscillator frequency. Transistor Q2 does not act exactly as a switch with only a full "on" or full "off" condition. It responds to the magnitude of the sine-wave signal applied to its base. Therefore, the percent of modulation or intensity can be adjusted through R6. The values of R8 and R9 (100,000 ohms) were chosen to provide up to 50% modu-

lation. Raising the value of R9 will decrease this percentage while lowering the value will increase it. Changing the value of R8 will accomplish the same thing but in the reverse of the above conditions.

**Construction.** The unit was completely assembled in a 3 $\frac{1}{4}$ " x 2 $\frac{1}{8}$ " x 1 $\frac{3}{8}$ " Mini-box (Bud CU-3001A), with a shielded cable going to the external foot switch. Although there is no critical requirement for parts placement, it is advisable to keep resistors R8 and R9 and the signal wires of J1 and P1 away from other components in the simulator. It is also advisable to use just one or two ground lugs and make certain that a good mechanical and electrical ground is obtained.

When selecting capacitors C1 and C2, consider using the Sprague "Hypercon" ceramic disc type, part numbers HY-330 and HY-135 respectively. These are high-capacitance, low-power-factor miniature ceramic discs. They are also low-priced. The manufacturer rates them with a capacitance tolerance of guaranteed minimum value. In checking an assortment of these capacitors on a bridge, it was found that the 0.47- $\mu$ f. units (HY-330) invariably exceeded 0.5  $\mu$ f. and the 1- $\mu$ f. units (HY-135) were closer to 1.5  $\mu$ f. When selecting capacitor C3, consider using a 4- $\mu$ f. electrolytic rather than a 5- $\mu$ f. unit. The low-priced variety of miniature electrolytics have

capacitance tolerances of  $-20$  to  $+150$ , the higher tolerance usually being the case.

The capacitors listed above were used in the author's model with excellent results. Of course, if standard-sized components are employed, which normally have a  $\pm 20\%$  tolerance, the specified values of  $0.5 \mu\text{f.}$ ,  $1.5 \mu\text{f.}$ , and  $5 \mu\text{f.}$  should be used.

Phone plug *P1* is a flat type with the plastic case removed. Drill a hole at one end of the chassis large enough to pass the plug connectors through. Drill three additional holes corresponding to the screw holes on the plug to facilitate mounting it to the chassis. The three screws removed with the plastic cover can be used for this purpose.

Mount the phone jack (*J1*) on the opposite end of the chassis. The two miniature potentiometers (*R2* and *R6*) are mounted on the bottom of the chassis. All electrical components are assembled using two 6-terminal strips mounted on the chassis bottom.

The foot switch is a momentary d.p.s.t. push-button type mounted in an ordinary molded plastic door stop, which can be purchased at most hardware stores. Since the simulator is battery-operated and does not have a pilot light, a momentary switch was used to eliminate the possibility of leaving the oscillator on when the simulator was not in operation. A push-on, push-off type switch can be employed if desired.

The cable for the foot switch is a miniature four-conductor shielded type (Belden 8434). This cable is excellent for this purpose because it contains two pairs of wire separately shielded. Using an unshielded cable, it was noticed that a small transient pulse caused by the opening and closing of *S1(A)* was picked up through the wires of *S1(B)* and transmitted to the amplifier as a click. If desired, two small-diameter, two-conductor cables (one shielded) can be employed. Use the shielded pair for the modulator circuit since this will also help minimize stray hum and pickup.

The author made some attempt to keep the unit small, which necessitated the use of miniature parts. These parts are generally more expensive and less readily available than standard size parts. There are, however, many differ-

ent ways in which the simulator can be built. For example, the entire unit can be assembled in a chassis fabricated to also serve as a foot switch (Bud chassis C-1606 can be used). This would eliminate the need for the shielded cable to the foot switch and would preclude the possibility of transient or hum pickup. The unit can also be assembled in a chassis which has provisions for mounting it to the amplifier case or chassis.

Another possibility would be to replace the 15-volt battery with an a.c.-operated power supply and assemble the entire unit in a chassis attached to the instrument amplifier chassis. In this case, the simulator could be switched on and off with the instrument power switch. The oscillator circuit could be left running, which would eliminate the need for switch *S1(A)*, and an s.p.s.t. switch could then be used for *S1(B)* to make and break the modulator circuit.

**Operation.** Once the vibrato simulator has been assembled, all that remains to be done is to put it to use. Plug the unit into the guitar amplifier and the guitar cable plug into connector *J1*. Adjust the guitar and amplifier controls for normal operation. With the foot switch open, the guitar operates in the normal manner. Depressing the foot switch couples the vibrato circuit into the amplifier input. Adjust *R2* for the desired vibrato speed and *R6* for the desired intensity.

It is unlikely that trouble will be encountered unless, of course, an error has been made in wiring. In case of trouble, carefully re-check the wiring, especially the terminals of *J1* and *P1*, since it is easy to reverse these connections and thereby ground the input or output of the unit. The oscillator can be checked for oscillation by connecting a VTVM between the collector and ground. A reading of approximately  $-3$  volts should be obtained. Also, the pointer of the meter will be moving at the oscillator rate. Check to see if the circuit oscillates through the complete rotation of *R2*.

It is possible to get a 2N1265/5 transistor with an extremely low gain factor. Therefore, try another transistor of the same type if everything else appears normal. The only other factor that could cause a problem is the variance in capacitance tolerances of *C1*, *C2*, or *C3*. -30-

# BUILD A Hi-Fi VOLUME



## COMPRESSOR

## EXPANDER

By ROGER H. RUSSELL

Add dynamic realism to FM stereo and to your tapes and records. Superbly designed and inexpensive to build, this little unit is alone in its class

**W**HILE NEW GADGETS for the audiophile have not been slow in making an appearance on dealers' shelves, at least one has been consistently shoved aside or completely ignored: the volume compressor-expander. Here, for the first time, is a method of controlling the dynamic range of your hi-fi system for less than \$25.00. And the low cost is not the only attractive feature. Hirsch-Houck laboratory tests reveal that this volume compressor-expander is virtually unmatched in its performance, even when compared to commercial units costing much more.

What exactly is volume compression-expansion? It's as simple as this: The dynamic (loudness) range of live program material is usually much wider than a recorder or broadcast transmitter can handle. If, for example,





Controls on front of unit (photo above) are threshold controls which determine the level at which expansion or compression takes place. Panel lamps *I1* and *I2* glow in proportion to the voltage of the audio tapped from speakers; switches control power, function.

Controls at rear of unit are d.c. balance pots which are adjusted initially. A cartridge, tuner, or other audio source is connected to inputs; outputs go to amplifier. Speaker jacks allow unit to sample amplifier output at speakers and react accordingly.



the gain is set halfway up, the soft parts will be accompanied by noise (tape hiss, hum, etc.) and the loud parts will be distorted from overdriving the recording or broadcast amplifier. Unfortunately, the solution to this problem—turning up the amplifier on soft passages and turning it down on loud ones—destroys the dynamic range of the original program material.

Since automatic volume compression is used to some extent in all commercial recording and broadcasting, volume expansion offers the audiophile an easy way to restore dynamic realism to a broadcast or to a tape or disc recording. On the other hand, the volume compression of which this unit is capable will be useful for those who want to listen to background music or who want to listen to the hi-fi without disturbing their neighbors.

**How It Works.** The idea of using a lamp and cadmium sulphide photocell in a feedback circuit is not new, but few experimenters have had the chance to try this circuit in their hi-fi systems. Use of transistor amplifiers—unique with this unit—allows expansion and compression at relatively low listening levels.

Output voltage at the speaker terminals of each stereo channel is used to drive a transistor amplifier/limiter which, in turn, controls the intensity of

a lamp. The intensity of the lamp causes the resistance of a cadmium sulphide photocell to change. The CdS cell is switched in a voltage divider to either aid or retard the input voltage to the amplifier.

Since the input impedance of the transistor amplifiers is high compared to the impedance of the speakers, connecting the unit to the speaker terminals has virtually no effect on speaker performance. With the d.c. balance controls (*R1* and *R2*) adjusted so the lamps just go out with *no* audio at the speakers, a slight voltage input at the bases of *Q1* and *Q2* will fire the transistors and the lamps will begin to glow. The lamps will glow brighter as higher voltage is applied to the point where the transistors begin to saturate. The amplifiers act as limiters at this point—since a higher input will not increase output—preventing the bulbs from burning out.

Photocells *PC1* and *PC2* are placed next to lamps *I1* and *I2* respectively, and vary in resistance from almost infinity when the lamps are dark to a few hundred ohms when they are brightly lighted. For volume expansion, the photocells are switched into the part of a voltage divider circuit in series with the audio source (tuner, phono cartridge, etc.) and the audio amplifier. Resistors *R5* and *R7* in the left channel, and *R8* and *R6* in the right channel, are selected

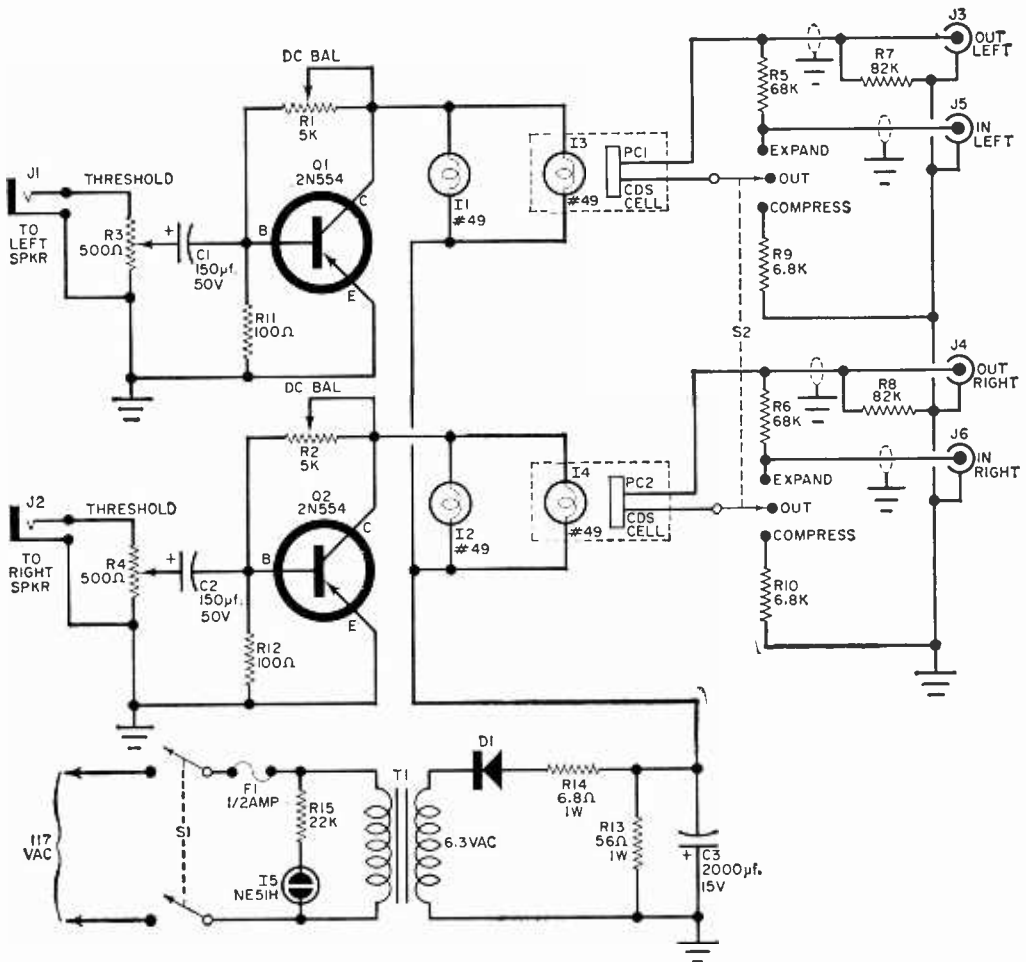

Simple circuit is duplicated for each channel. Basically, it consists of a transistor amplifier that drives a pilot bulb. Photocell for each channel is in a voltage divider circuit which changes value as the light falling on the cell changes.

## PARTS LIST

C1, C2—150- $\mu$ f., 50-volt electrolytic capacitor  
 C3—2000- $\mu$ f., 15-volt electrolytic capacitor  
 D1—200-PIV, 750-ma. "top hat" silicon diode  
 F1— $\frac{1}{2}$ -ampere fuse, type 3AG  
 I1, I2, I3, I4—#49 pilot lamp (GE)  
 I5—NE-51H neon bulb  
 J1, J2—Standard open-circuit phone jack (for speaker connections)  
 J3, J4, J5, J6—Phono pin jack (single mounting hole type)  
 PC1, PC2—Cadmium sulphide photocell (Lafayette 19 G 2101 or equivalent)  
 Q1, Q2—2N554 power transistor (Motorola) or equivalent  
 R1, R2—5000-ohm, 4-watt wire-wound potentiometer  
 R3, R4—500-ohm, 4-watt wire-wound potentiometer  
 R5, R6—68,000-ohm,  $\frac{1}{2}$ -watt, 5% resistor  
 R7, R8—82,000-ohm,  $\frac{1}{2}$ -watt, 5% resistor  
 R9, R10—6800-ohm,  $\frac{1}{2}$ -watt, 5% resistor  
 R11, R12—100-ohm, 1-watt, 5% resistor

R13—56-ohm, 1-watt, 10% resistor  
 R14—6.8-ohm, 1-watt, 10% resistor  
 R15—22,000-ohm,  $\frac{1}{2}$ -watt, 10% resistor  
 S1, S2—4-pole, 3-position rotary switch (Lafayette 99 G 2002 or equivalent)  
 T1—Filament transformer, 6.3 volts @ 1 ampere  
 1—Bakelite cabinet (Lafayette 19 G 2002,  $2\frac{1}{4}$ " x  $5\frac{1}{4}$ " x  $6\frac{3}{4}$ ", or similar)  
 1—Panel for cabinet above (Lafayette 19 G 3702)  
 2—Panel lamp assemblies for I1 and I2 (Dialco 930 series less resistor or equivalent)  
 1—Bayonet-type bulb holder for I5  
 1—Fuse holder for 3AG fuse  
 1—Length of polystyrene tubing,  $\frac{3}{4}$ " o.d.,  $\frac{5}{8}$ " i.d. (Lafayette 13 G 5126 or equivalent)  
 1— $\frac{1}{8}$ " polystyrene sheet cut to  $1\frac{3}{4}$ " x  $2\frac{3}{4}$ " for mounting Q1 and Q2  
 Misc.—Rubber grommets, terminal strips, 6-32 x  $\frac{1}{4}$ " hardware, knobs, wire, shielded cable, a.c. line cord, small brackets for mounting Q1-Q2 mounting board, cement, tape, plastic lens for I5, etc.

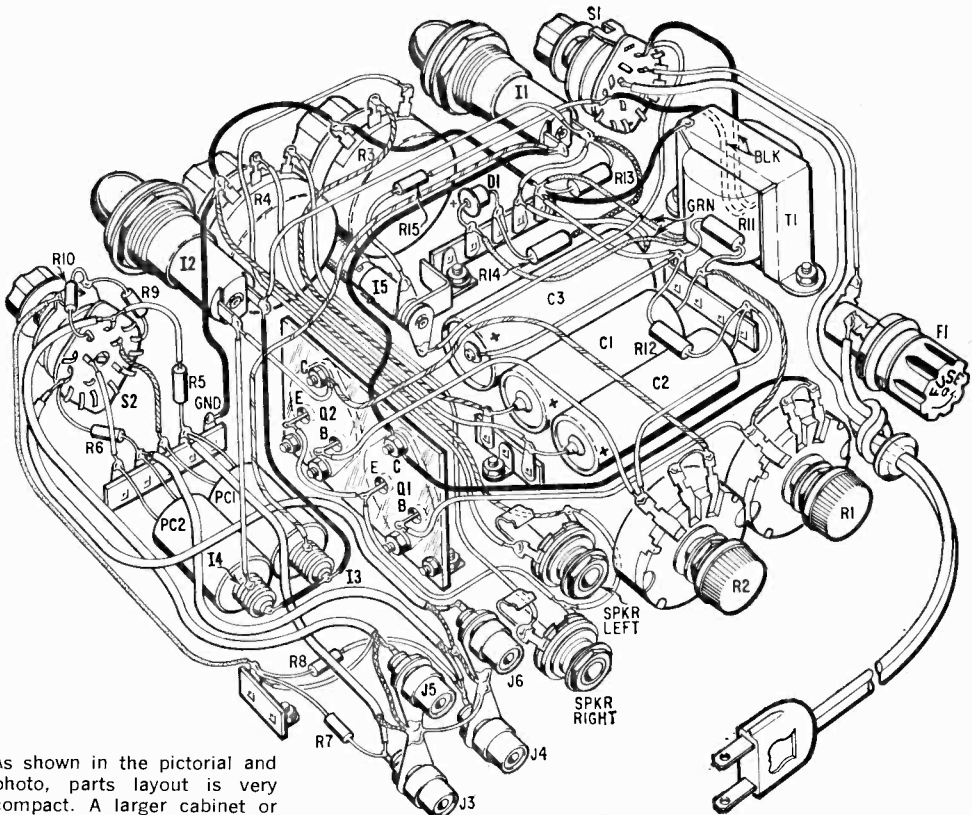

As shown in the pictorial and photo, parts layout is very compact. A larger cabinet or metal chassis can be used if desired, allowing loose layout.

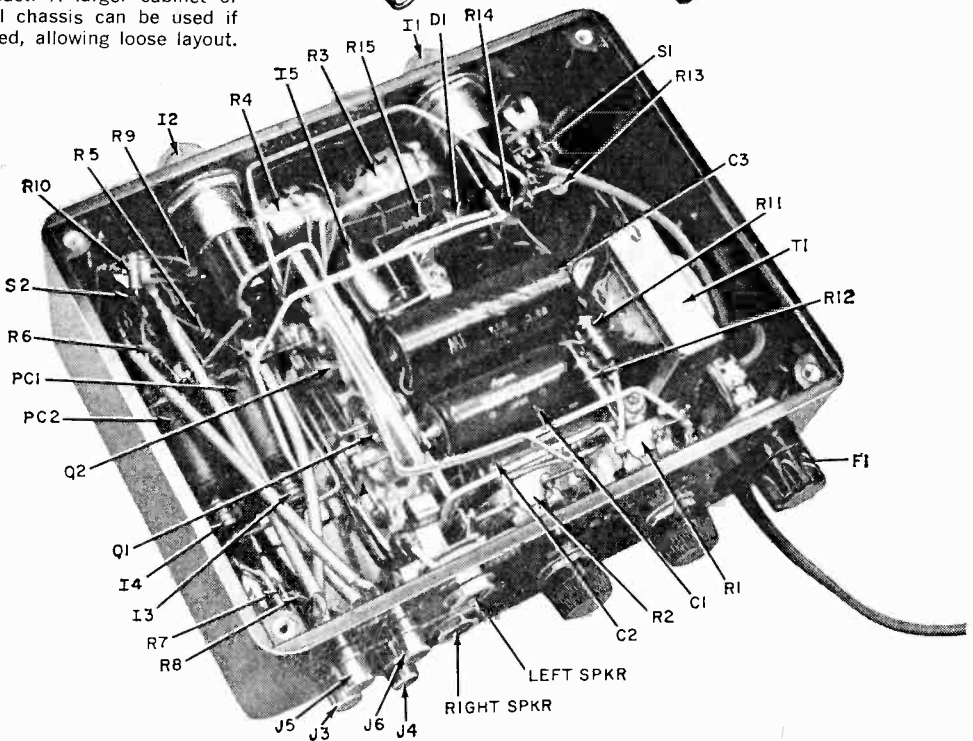

to give the desired amount of expansion—about 6 db in this case—as the resistance of *PC1* and *PC2* changes. Voltage relationships for expansion can easily be seen in the curve below. With the unit in the “out” position (*PC1* and *PC2* out of the circuit), any increase in audio input results in an equal increase in output as shown by the straight-line “out” curve.

In the “expand” position, a small increase in the input causes a large increase in output, and this *unequal* change in voltages is where expansion occurs. Did we get something for nothing? No, because the output was 6 db less than the input to start with (6 db is the “line” or insertion loss of the unit), but the amplifier doesn’t know this. On “expand,” it sees the output only as a fast rising voltage.

For compression, *PC1* and *PC2* are switched into voltage dividers that now include *R9* and *R10* as well as *R5* and *R7* and *R6* and *R8*. Here, *PC1* and *PC2* are connected in parallel across the audio source in combination with *R9* and *R10* respectively. As shown by the “compress” curve below, a large increase in input results in a small increase in output. This unequal change is where

compression occurs, to a maximum of 15 db. The amplifier now sees the output as a slowly rising voltage.

The amount of expansion is determined by the size of resistor *R5* with respect to resistor *R7*, and the size of *R6* with respect to *R8*. If *R5* and *R6* are made larger, more expansion may be obtained; if they are made smaller, less expansion will result. On “compress,” smaller values for resistors *R9* and *R10* will give more compression; larger values will give less.

**Construction.** Although a metal chassis can be used for the compressor-expander, a Bakelite instrument case was selected for ease of construction—it can be drilled and filed much like wood—and compactness. Place drafting tape on the front and rear of the case and use a pencil to locate holes to be drilled. Larger holes should be filed or reamed as large drills can cause chips around the hole being cut.

Mount the components using lock washers on the inside to prevent slippage on the smooth Bakelite. The power transistors do not require a heat sink in this application and are mounted on a piece of clear polystyrene. If transistors *Q1* and *Q2* are mounted on a metal

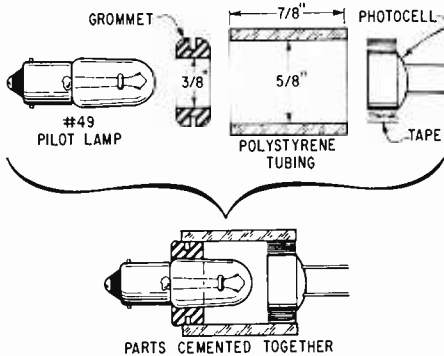

Photocell-pilot lamp assemblies—one for each channel—are constructed as detailed here (see text).

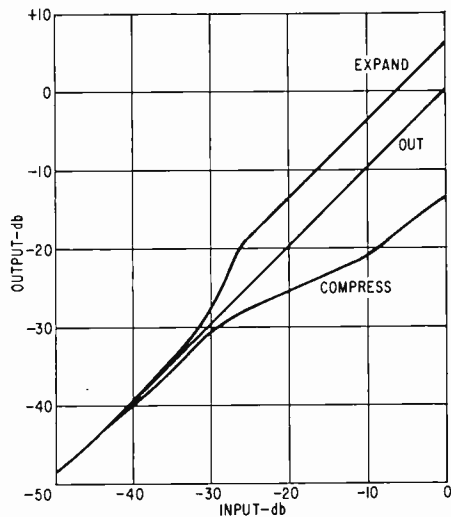

Hirsch-Houck laboratory curve shows 6 db expansion and a maximum of 15 db compression for P.E. unit.

chassis, insulation must be used between them and the chassis.

Assembly of the two photocell-lamp units is easy. As shown on page 45, cut a  $\frac{7}{8}$ " length of  $\frac{5}{8}$ "-i.d. polystyrene tubing for each. Push a #49 lamp into a  $\frac{3}{8}$ " grommet and insert the grommet and bulb into one end of the tube. Wrap  $\frac{1}{4}$ " wide tape around each photocell, using enough so they will fit smoothly in the ends of the tubes opposite the bulbs. Cement each assembly in place. Both of the assemblies should be painted black so that external light won't affect the resistance of the photocells. To make sure they are light-tight, measure the resistance of the photocell-lamp assemblies in normal reading light—if it's less than one megohm, check for leaks. Caulking compound is a good material for sealing leaks around the bulbs and photocells.

**Wiring the Unit.** Two separate grounding systems are used in the compressor-expander to avoid possible hum loops in the amplifier to be used with it. The speaker ground leads and power supply ground form one system; the shielded leads for the input-output circuit and photocell section form the other system.

Wiring is straightforward. Use different colors of wire for leads associated with the left and right channels to make checking the circuit easy; use shielded wire for the input-output circuit connections. Polarity of *D1* and *C1*, *C2* and *C3* must be observed.

Care should be taken when soldering to the lugs of the germanium power transistors, which can be easily damaged by heat from the soldering iron. Use a heat sink between the solder joint and the body of the transistor, or use a transistor wafer socket. If a wafer socket is used, the leads can be soldered

to the socket prior to pushing over the transistor lugs. This will make it possible to avoid direct soldering to the transistor.

Resistors associated with the input-output circuit should be accessible as you may want to experiment with the amount of expansion and compression in the future.

As finishing touches, add rubber feet to the cabinet, and label the controls with decals.

**Hookup and Final Adjustments.** Connect the compressor-expander into your stereo system as shown in the drawing below. The amplifier input impedance should range between 50,000 ohms and 1 megohm. The transistor portion of the circuit must be connected to the power amplifier speaker terminals; be sure to connect the ground of the speaker terminals to the ground of the transistor circuit. The input-output circuit can be connected between the preamp output-power amp input, tuner or tape recorder output-preamp input, or the magnetic cartridge output-preamp input.

To use the compressor-expander, turn it on and set the amplifier volume con-

#### HIRSCH-HOUCK REPORT

The 6 db expansion was definitely more pleasing than the 8.5 db of a comparable commercial unit. The compression was more than adequate. Under conditions of compression or expansion there was no high-frequency loss. The unit was easy to install and adjust, and did all that could be expected. Well planned and constructed . . .

trol to zero. Adjust the d.c. balance controls (*R1* and *R2* at the rear of the case) so the corresponding front panel lamps, *I1* and *I2*, just go out. Next, set the front-panel threshold controls, *R3* and *R4*, to maximum clockwise and turn up the amplifier volume to a normal

Simply connect compressor-expander between audio source and amplifier.

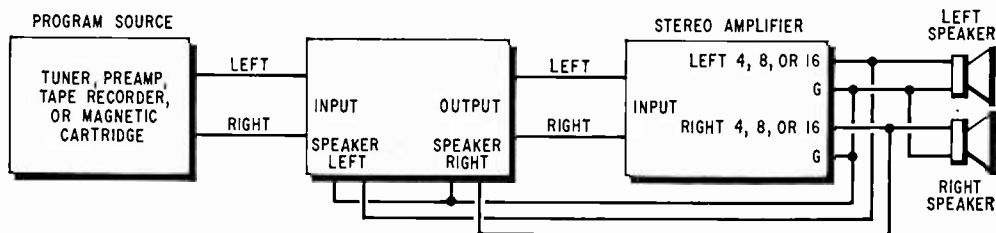



**For less than \$15 you can  
build real convenience  
into your hi-fi stereo system**

**I**N THIS AGE of automation, it's ridiculous to have to throw more than one switch to accomplish one ultimate function. If, for example, you want to listen to a record, why should you first have to turn on the phonograph, then the amplifier? With the "Hi-Fi Interlock," turning on the phonograph (or the FM tuner or the tape recorder) also turns on the amplifier. An auxiliary benefit accrues in that turning off the primary device also turns off the secondary, or controlled device, preventing the possibility of leaving the amplifier on all night to cook up lots and lots of heat.

**How It Works.** Diodes *D2* and *D3* are connected back-to-back in series with sockets *SO1* through *SO4*, and then across the a.c. line. A load applied to these sockets will cause a voltage drop in the diodes, activating the relay-controlling circuit at *Q1*, and causing relay *K1* to pull in and apply full 117-volt a.c. to socket *SO5* where the controlled devices are connected.

When a load is applied at sockets *SO1* through *SO4*, diode *D2* or *D3* will conduct (one or the other, depending on the a.c. polarity at the time), providing a negative base voltage for transistor *Q1*. This base is normally held positive by the bias supply formed by diode *D1*, capacitor *C1* and resistor *R1*. Diode *D2* limits the voltage to 0.75 volt. Resistor *R2* is used to limit base current, and capacitor *C2* is used as a filter for the half-wave d.c. that is applied to relay *K1* by transistor *Q1*.

**Mounting the Components.** All of the components are mounted in a small, open-end chassis. While parts placement is not critical, you can obtain a general idea of the arrangement the author used by examining the pictorial diagram on page 60.

Mount the larger components first—the transformer, relay, and transistor. Next mount diodes *D2* and *D3*, then the

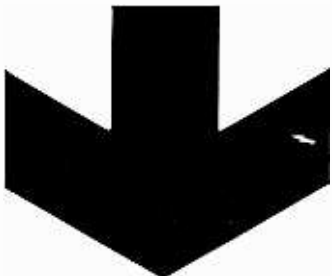

# Build Hi-Fi INTERLOCK



**By CHARLES J. ULRICK**





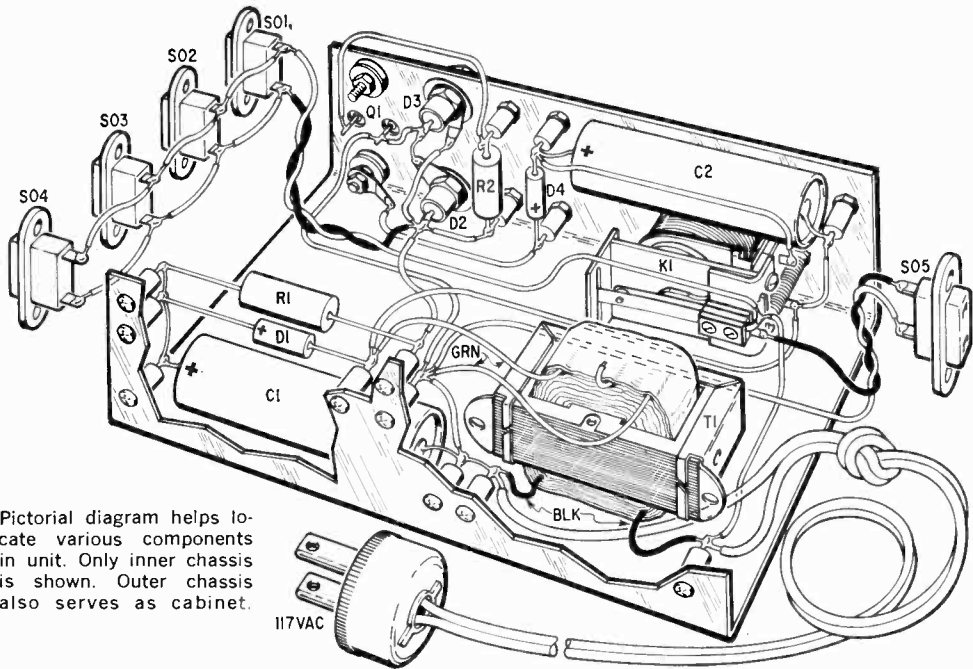

Pictorial diagram helps locate various components in unit. Only inner chassis is shown. Outer chassis also serves as cabinet.

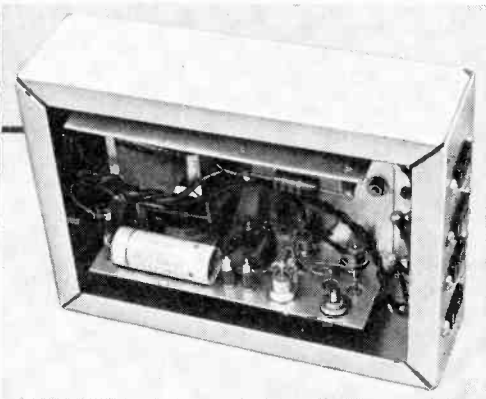
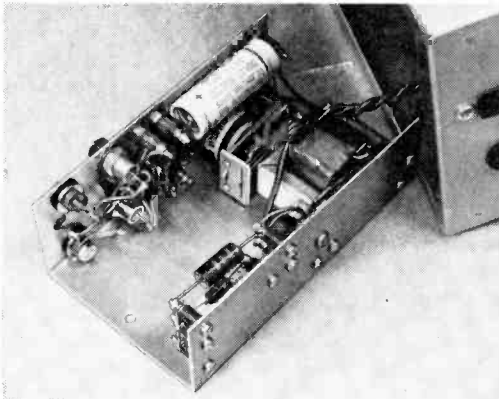

After wiring, subchassis (above, left) is installed in larger chassis and fastened in place.

the unit has been tested and is working properly.

Following the schematic diagram, carefully wire the small subchassis, twisting the wires to the sockets before soldering them into place. Before wiring the line cord into place, knot it so it will act as a strain relief.

Be sure to deburr all mounting holes to guarantee proper fit. This can best be accomplished by the judicious use of a  $\frac{1}{8}$ " or  $\frac{3}{4}$ " twist drill, gently rotated by hand.

**Using the Interlock.** To install the interlock in a high-fidelity stereo system, plug the various controlling units into sockets *SO1* through *SO4*. The interlock is then plugged into a wall outlet and the unit to be controlled is connected at *SO5*. If it is necessary to control more than one unit, a cube-tap can be connected to *SO5*, or more sockets can be added. Other applications for the interlock will be found in the ham or CB shack, or wherever remote or automatic power switching is needed.

# Build the SHOTGUN SOUND SNOOPER

*Operating on "organ pipe"  
principles, this amazing  
tubular microphone  
amplifies distant sounds*

By JAMES R. HOLLINGER and  
JOHN E. MULLIGAN, K3TIB

ONE WINDY DAY last fall, the authors hustled a skeptical friend out into a field bordering on a wooded area to test a homemade long-range tubular microphone. Waiting until the friend had crossed the field and disappeared completely, we panned the mike toward the spot where he had last been seen. At first only the sounds of birds were heard; then, on the last swing, came the sound of crashing brush and a voice mumbling "Mary had a little lamb." When we told him later that we had enjoyed his nursery rhyme, he looked at us incredulously. At a range of 250 yards, under adverse wind conditions, we had picked his voice out of the woods!

The tubular microphone, one of the less publicized but one of the most spectacular long-range listening devices, might be described as a bundle of open-end tubes designed to pick up and amplify sounds of different frequencies by virtue of different tube lengths. The principles involved are familiar: In re-

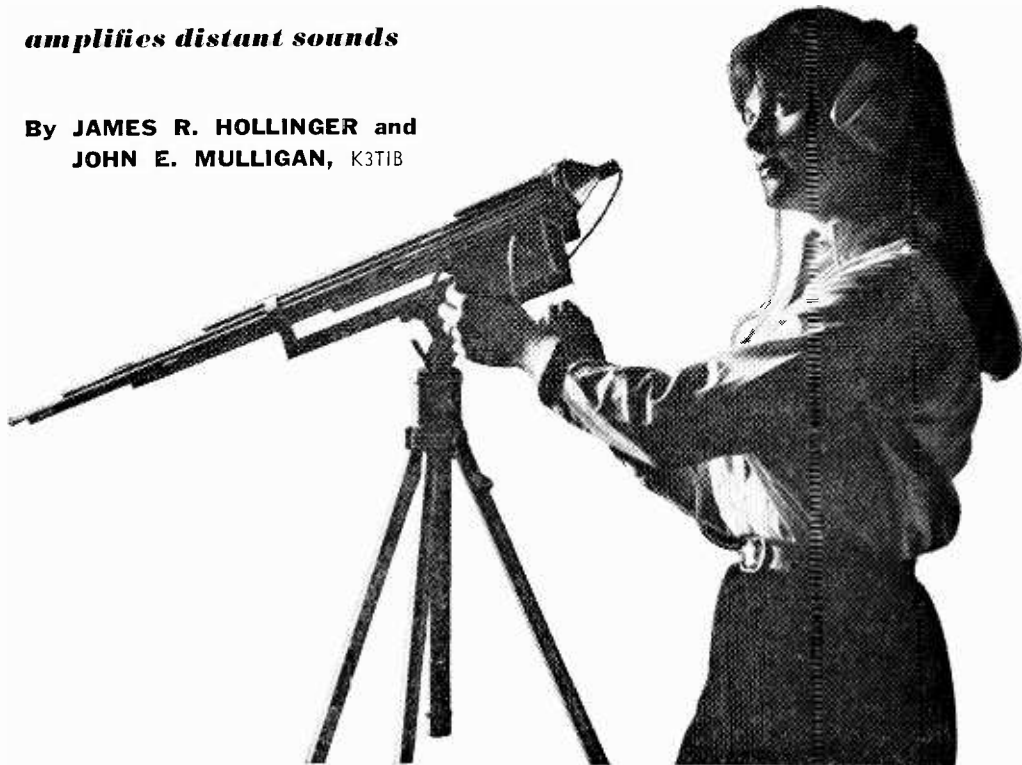

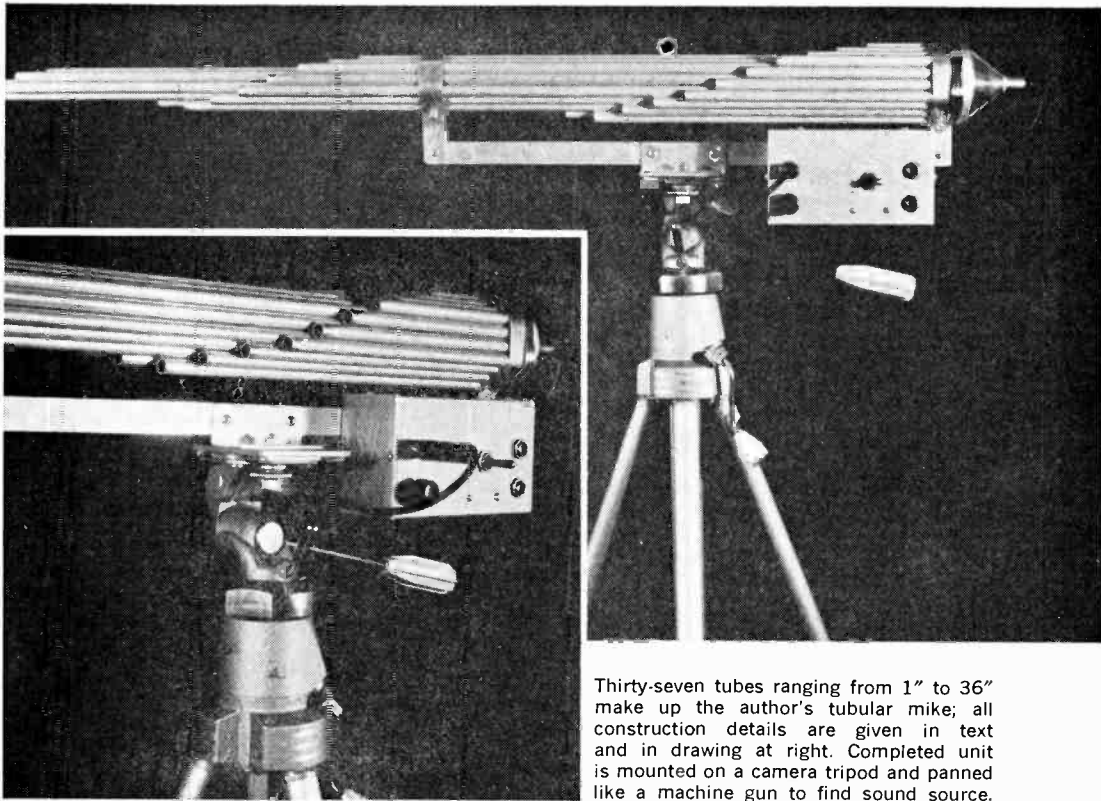

Thirty-seven tubes ranging from 1" to 36" make up the author's tubular mike; all construction details are given in text and in drawing at right. Completed unit is mounted on a camera tripod and panned like a machine gun to find sound source.

sponse to sounds of various frequencies, the air columns within each tube vibrate and, in doing so, amplify the original sounds.

Applications of the tubular mike, which has far greater sensitivity, better frequency response, and superior directional characteristics than parabolic types, are many. Bird and animal watchers are delighted with the added dimension of sound when it is applied to nature studies. Small boat operators may find the unit of value as a navigational aid, especially in fog or conditions of poor visibility. The tubular mike can pick up conversations from busy streets, and under the right conditions, can actually pick up conversation through closed windows 40 or more yards away.

**Design and Construction.** As you might assume, tubes are cut to resonate over a specific range of frequencies. To calculate tube length, first find wavelength by dividing the speed of sound (1100 feet per second for practical purposes) by the frequency. For example, the wavelength of 256 cycles equals 1100

÷ 256, or 4.296 feet. *Tube length*, however, is half this, or 2.14 feet, since tubes open at both ends resonate at a wavelength twice as long as their length.

In designing a tubular mike, it is necessary only to assemble enough tubes to cover the frequency range of sounds you want to hear. The exact number of tubes is not critical, but should be the greatest number that can be efficiently covered by the microphone element. The range of tube lengths may vary too. Some builders may wish to use tubes longer than those suggested here for increased pickup of the lower frequencies. The graduated lengths should be stepped evenly from the shortest to the longest so frequency nulls are avoided.

The "Shotgun Sound Snooper", designed for portability, is built with 37 aluminum tubes,  $\frac{3}{8}$ " O.D., ranging from 1" to 36" in length, and graduated in 1" steps. The 37th tube is an extra 1" length added to complete the hexagonal symmetry of the pickup. The tubes can be conveniently cut from ten 6' lengths, using a tubing cutter or fine-tooth hack-

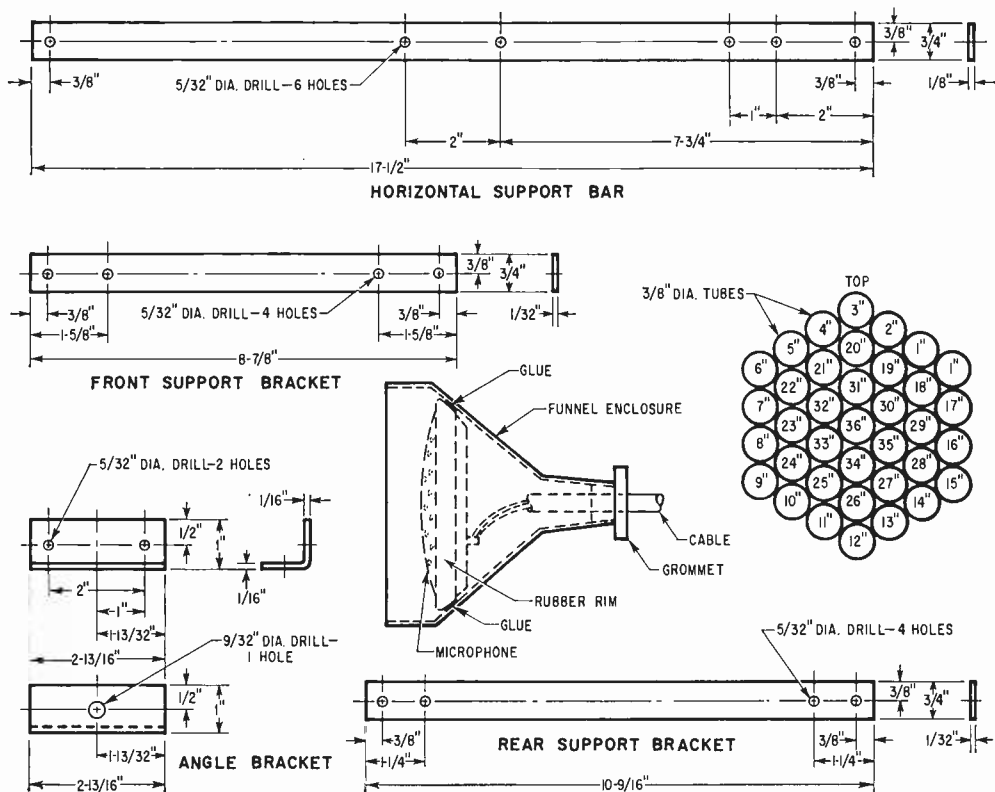

Easily worked aluminum is used for fabricating the pickup. The tubes can be conveniently cut from ten 6' lengths of 3/8" diameter stock, the support brackets

from a sheet or strip of 1/32" aluminum. The horizontal support bar is made from heavier stock. Angle bracket mounts to standard camera tripod.

### BILL OF MATERIALS FOR MICROPHONE

- 1—56' length of 3/8"-O.D. aluminum tubing (ten 6' lengths preferable)
- 1—Crystal microphone cartridge, approx. 2 1/8"-diameter (Lafayette PA-27 or equivalent)
- 1—Household funnel, 2 3/4"-diameter (or equiv.)
- 1—3/4"-wide, 1/32"-thick aluminum strip for support brackets, battery bracket (approx. 2' required)

- 1—3/4"-wide, 1/8"-thick aluminum strip for horizontal support bar (approximately 1 1/2' length required)
- 1—Standard camera tripod
- Misc.—Glue (fast-drying rubber base contact cement or epoxy glue), 8-32 machine screws and nuts, rubber grommet, microphone cable solder, etc.

saw. Dress the edges with a fine file to remove burrs. Assemble the tubes as shown in the drawing above, starting with the 36" length and gluing the 35" tube to it for the entire length. The authors used fast-drying rubber base cement, but epoxy glue can be used for greater strength. In any case, be sure the tubes are flush at one end by checking each one against the others as you glue them in place. Don't worry about the spaces between the tubes; they simply become air columns.

Cut and drill the front and back support brackets from easily worked 1/32"-

thick aluminum as shown in the drawings. The brackets are shaped around the tubes to form a tight fit; it will be a tight fit if you bend each one at the exact center to form a slight V before you shape them. Make the horizontal support bar from 1/32" aluminum as shown, and cut off a piece of aluminum angle to form the angle bracket.

**Cartridge Mounting.** The microphone cartridge enclosure is made from a 2 1/4"-diameter household funnel, but can be improvised from sheet metal. The shape of the enclosure is not important, provided it permits the microphone car-

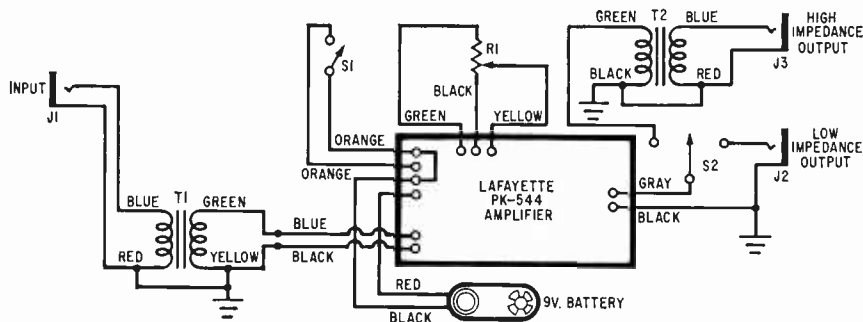

Wire amplifier and other components as above; T2, S2, J3 are optional.

### AMPLIFIER PARTS LIST

- J1, J2, J3—Standard open-circuit phone jack
- R1—10,000-ohm miniature potentiometer with s.p.s.t. switch S1 (Lafayette 32-G-7364 or equiv.)
- S1—Part of R1
- S2—S.p.d.t. toggle switch
- T1—Transistor input transformer; 200,000-ohm primary, 1000-ohm secondary (Lafayette 99-G-6034 or equivalent)
- T2—Transistor output transformer; 2500-ohm primary, 11-ohm secondary (Argonne AR-114 or equivalent)
- 1—Lafayette PK-544 5-transistor audio amplifier or other high-gain amplifier
- 1—9-volt transistor battery (Burgess 2U6 or equivalent)
- 1—Aluminum box, approximately 2 1/8" x 3" x 5 1/4" (LMB #136 or equivalent)
- 1—Miniature knob (Lafayette 32-G-2405)
- 1—18" length of single-conductor shielded microphone cable
- 1—Set of headphones, high or low impedance
- Misc.—4-40 x 5/8" machine screws and extra nuts, scrap aluminum, contact cement or epoxy glue, wire, solder, etc.

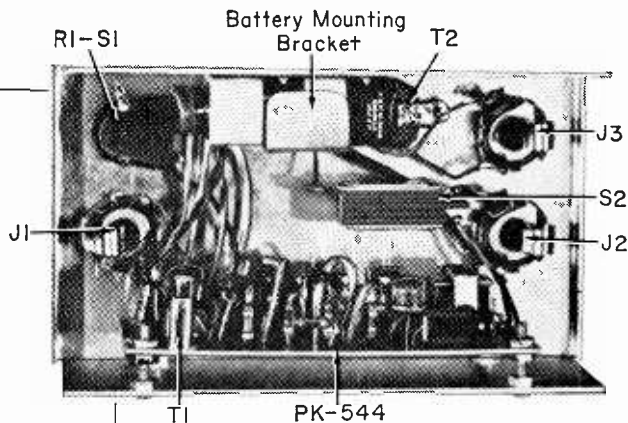

Follow parts placement indicated (unit is inverted in this photo) to avoid possible feedback problems.

tridge to be mounted very close to the ends of the tubes. Hold the wide end to the tube cluster and mark the sides to indicate the corners of the hexagonal shape. Place the funnel on a smooth, solid surface, and make dents at each of the six corners of the hexagon with a small ball peen hammer. With the flat head of the hammer, flatten the areas between the indentations for about 1/4" in from the edge of the funnel. Place it over the end of the tube cluster and peen again if necessary. A tight sliding fit is desirable, but a loose fit can be remedied with tape.

As shown in the drawing on page 63, the rubber-rimmed microphone cartridge is mounted in the funnel with

glue. It is important at this point to make sure the cartridge will position as close as possible to the ends of the tubes without actually touching them when the enclosure is fitted to the tubes. The cartridge must be insulated from the enclosure, either by the rubber rim which is part of the recommended cartridge, or by some equivalent means. The space behind the microphone element may be packed with a sound insulating material such as glass wool or foam plastic to help reduce pickup from the rear. Before placing the cartridge, first connect a length of mike cable and install a rubber grommet in the small end of the funnel; apply glue to the rubber rim of the mike cartridge and to the funnel. Press the cartridge into the funnel, truing it up and clamping it into position until the glue is dry.

**Final Assembly.** Place the rear support bracket over the tube cluster 1/4" forward of the flush end and tighten it onto the  
(Continued on page 144)

# BUILD YOUR OWN RADIO

Reg. U. S.  
Pat. Off.



Training Electronics Technicians Since 1946

**CIRCUITS AT HOME**  
with the Deluxe

only  
**\$26.95**

**PROGRESSIVE RADIO "EDU-KIT"®**

**A Practical Home Radio Course**

**Now Includes**

- ★ 12 RECEIVERS
- ★ 3 TRANSMITTERS
- ★ SQ. WAVE GENERATOR
- ★ SIGNAL TRACER
- ★ AMPLIFIER
- ★ SIGNAL INJECTOR
- ★ CODE OSCILLATOR
- ★ No Knowledge of Radio Necessary
- ★ No Additional Parts or Tools Needed
- ★ EXCELLENT BACKGROUND FOR TV
- ★ **SCHOOL INQUIRIES INVITED**
- ★ Sold in 79 Countries

**YOU DON'T HAVE TO SPEND  
HUNDREDS OF DOLLARS FOR A RADIO COURSE**

The "Edu-Kit" offers you an outstanding PRACTICAL HOME RADIO COURSE at a rock-bottom price. Our Kit is designed to train Radio & Electronics Technicians, making use of the most modern methods of home training. You will learn radio theory, construction practice and servicing. THIS IS A COMPLETE RADIO COURSE IN EVERY DETAIL. You will learn how to build radios, using regular schematics; how to wire and solder in a professional manner; how to service radios. You will work with the standard type of punched metal chassis as well as the latest development of Printed Circuit chassis. You will learn the basic principles of radio. You will construct, study and work with RF and AF amplifiers and oscillators, detectors, rectifiers, test equipment. You will learn and practice code, using the Progressive Code Oscillator. You will learn and practice trouble shooting using the Progressive Signal Tracer, Progressive Signal Injector, Progressive Dynamic Radio & Electronics Tester, Square Wave Generator and the accompanying instructional material.

You will receive training for the Novice, Technician and General Classes of F. C. C. Radio Amateur Licenses. You will build Receiver, Transmitter, Square Wave Generator, Code Oscillator, Signal Tracer and Signal Injector circuits, and learn how to operate them. You will receive excellent background for television, radio and electronics.

Absolutely no previous knowledge of radio or science is required. The "Edu-Kit" is the product of many years of teaching and engineering experience. The "Edu-Kit" will provide you with a basic education in Electronics and Radio, worth many times the low price you pay. The Signal Tracer alone is worth more than the price of the kit.

**THE KIT FOR EVERYONE**

You do not need the slightest background in radio or science. Whether you are interested in Radio & Electronics because you want an interesting hobby, a well paying business or a job with a future, you will find the "Edu-Kit" a worthwhile investment. Many thousands of individuals of all

ages and backgrounds have successfully used the "Edu-Kit" in more than 79 countries of the world. The "Edu-Kit" has been carefully designed, step by step, so that you cannot make a mistake. The "Edu-Kit" allows you to teach yourself at your own rate. No instructor is necessary.

**PROGRESSIVE TEACHING METHOD**

The Progressive Radio "Edu-Kit" is the foremost educational radio kit in the world, and is universally accepted as the standard in the field of electronics training. The "Edu-Kit" uses the modern educational principle of "Learn by Doing." Therefore you construct, learn schematics, study theory, practice trouble shooting—all in a closely integrated program designed to provide an easily-learned, thorough and interesting background in radio. You begin by examining the various radio parts of the "Edu-Kit." You then learn the function, theory and wiring of these parts. Then you build a simple radio. With this first set you will enjoy listening to regular broadcast stations; learn theory, practice testing and trouble shooting. Then you build a more advanced radio, learn more advanced theory and techniques. Gradually, in a progressive manner, and at your own rate, you will find yourself constructing more advanced multi-tube radio circuits, and doing work like a professional Radio Technician.

Included in the "Edu-Kit" course are Receiver, Transmitter, Code Oscillator, Signal Tracer, Square Wave Generator and Signal Injector Circuits. These are not unprofessional "breadboard" experiments, but genuine radio circuits, constructed by means of professional wiring and soldering on metal chassis, plus the new method of radio construction known as "Printed Circuitry." These circuits operate on your regular AC or DC house current.

**THE "EDU-KIT" IS COMPLETE**

You will receive all parts and instructions necessary to build twenty different radio and electronics circuits, each guaranteed to operate. Our Kits contain tubes, tube sockets, variable, electrolytic, mica, ceramic and paper dielectric condensers, resistors, tie strips, hardware, tubing, punched metal chassis, instruction Manuals, hook-up wire, solder, selenium rectifiers, coils, volume controls and switches, etc.

In addition, you receive Printed Circuit materials, including Printed Circuit chassis, special tube sockets, hardware and instructions. You also receive a useful set of tools, a professional electric soldering iron, and a self-powered Dynamic Radio and Electronics Tester. The "Edu-Kit" also includes Code Instructions and the Progressive Code Oscillator in addition to F. C. C. Radio Amateur License training. You will also receive lessons for servicing with the Signal Tracer and the Progressive Signal Injector, a High Fidelity Guide and a Quiz Book. You receive Membership in Radio-TV Club, Free Consultation Service, Certificate of Merit and Discount Privileges. You receive all parts, tools, instructions, etc. Everything is yours to keep.

**PRINTED CIRCUITRY**

At no increase in price, the "Edu-Kit" now includes Printed Circuitry. You build a Printed Circuit Signal Injector, a unique servicing instrument that can detect many Radio and TV troubles. This revolutionary new technique of radio construction is now becoming popular in commercial radio and TV sets.

A Printed Circuit is a special insulated chassis on which has been deposited a conducting material which takes the place of wiring. The various parts are merely plugged in and soldered to terminals.

Printed Circuitry is the basis of modern Automation Electronics. A knowledge of this subject is a necessity today for anyone interested in Electronics.

**FREE EXTRAS**

- SET OF TOOLS
- SOLDERING IRON
- ELECTRONICS TESTER
- PLIERS-CUTTERS
- VALUABLE DISCOUNT CARD
- CERTIFICATE OF MERIT
- TESTER INSTRUCTION MANUAL
- HIGH FIDELITY GUIDE • QUIZZES
- TELEVISION BOOK • RADIO TROUBLE-SHOOTING BOOK
- MEMBERSHIP IN RADIO-TV CLUB: CONSULTATION SERVICE • FCC AMATEUR LICENSE TRAINING
- PRINTED CIRCUITRY

**SERVICING LESSONS**

You will learn trouble-shooting and servicing in a progressive manner. You will practice repairs on the sets that you construct. You will learn symptoms and causes of trouble in home, portable and car radios. You will learn how to use the professional Signal Tracer, the unique Signal Injector and the dynamic Radio & Electronics Tester. While you are learning in this practical way, you will be able to do many a repair job for your friends and neighbors, and charge fees which will far exceed the price of the "Edu-Kit." Our Consultation Service will help you with any technical problems you may have.

**FROM OUR MAIL BAG**

J. Stataitis, of 25 Poplar Pl., Waterbury, Conn., writes: "I have repaired several sets for my friends, and made money. The "Edu-Kit" paid for itself. I was ready to spend \$240 for a Course, but I found your ad and sent for your Kit."

Ben Valerio, P. O. Box 21, Magna, Utah: "The Edu-Kits are wonderful. Here I am sending you the questions and also the answers for them. I have been in Radio for the last seven years, but like to work with Radio Kits, and like to build Radio Testing Equipment. I enjoyed every minute I worked with the different kits; the Signal Tracer works fine. Also like to let you know that I feel proud of becoming a member of your Radio-TV Club."

Robert L. Shuff, 1534 Monroe Ave., Huntington, W. Va.: "Thought I would drop you a few lines to say that I received my Edu-Kit, and was really amazed that such a bargain can be had at such a low price. I have already started repairing radios and phonographs. My friends were really surprised to see me get into the swing of it so quickly. The Trouble-shooting Tester that comes with the Kit is really swell, and finds the trouble, if there is any to be found."

**UNCONDITIONAL MONEY-BACK GUARANTEE**

**ORDER FROM AD—RECEIVE FREE BONUS  
RADIO & TV PARTS JACKPOT WORTH \$15**

- Send "Edu-Kit" postpaid. I enclose full payment of \$26.95.
- Send "Edu-Kit" C.O.D. I will pay \$26.95 plus postage.
- Rush me FREE descriptive literature concerning "Edu-Kit."

Name.....

Address.....

**PROGRESSIVE "EDU-KITS" INC.**

(ATT: S. GOODMAN, M.S. IN ED., PRES.)

1186 Broadway, Dept. 511RR, Hewlett, N. Y. 11557

CIRCLE NO. 22 ON READER SERVICE CARD

# HALF-PRICE

on a subscription to

# POPULAR ELECTRONICS!

**18** exciting months **\$3.00** only

At the regular subscription rate these same 18 issues would cost all of \$6.00! BUT NOT FOR YOU. Your cost is only \$3.00—HALF-PRICE!

Every month POPULAR ELECTRONICS brings you a wealth of fascinating features aimed especially at experimenters and do-it-yourselfers like yourself. (Just glance to the right for a sample!)

You'll enjoy being right on top of the fast-growing world of electronics with up-to-the-minute new product reports, lab tests, buying guides, and electronics breakthroughs you want to know about. Plenty of articles on hi-fi, money-saving test equipment, tape recorders, electronic games, computers, photo-aids, short wave receivers, antenna systems, solar powered and transistorized equipment—and much more.

Construction projects galore! Clear-as-crystal diagrams guide you each step of the way through fun-to-build projects you can put together in just a few hours... for pennies! Turn friends green with envy by building a super hi-fi rig they couldn't match in the stores for hundreds of dollars! Or throw together a fool-proof photoelectric burglar alarm to protect your home and loved ones... or a remote control switch that actually turns lights on and off when you whistle a bar of your favorite tune!

**POPULAR ELECTRONICS is definitely for men like YOU. Take advantage of this HALF-PRICE OFFER to readers of the Experimenter's Handbook. Just complete and mail the card facing this page. Or, if someone has already used the card, write to: POPULAR ELECTRONICS, Dept. 4080, Portland Place, Boulder, Colorado 80311**



## EXCLUSIVE HAM, SW & CB ARTICLES IN POPULAR ELECTRONICS

### Amateur Radio and SWL

Make Your Signal Reports More Accurate  
Safety in the Ham Station  
Amateur License Fees and ARRL Petitions  
Take Advantage of Changing Propagation Conditions

Operating Another Ham's Station  
Calling All SWL DX'ers  
DX Awards  
English-Language Newscasts to North America  
Radio Marathon Broadcasts Truth To Cuba  
Satellites on the Air  
Short-Wave Broadcast Predictions  
Short-Wave Report  
North American Alliance of SWL Clubs  
Welcome to the SWL Newcomer  
Sure Cure for Ham/CB Mobile Noise

### Citizens Band Radio

"DSRC," New CB Features  
Equipment Buyer's Guide  
Transmitters and Transceivers  
Station Accessories  
Antennas  
Microphones  
Hand-Held Transceivers  
FCC Report  
On the Citizens Band  
Sure Cure for Ham/CB Mobile Noise  
Vibrator Hash, Wipe Out

### Build-It-Yourself

Antenna, 40-Meter, for Small Roof  
Antenna Adapter, Power Line  
Code Bander  
Crystal Super Calibrator  
Double-Duty EICO 772  
Hula-Hoop—a Ham or CB Antenna  
Idento-Minder  
Q-Multiplier, Nuvistor  
Screen Modulator, One-Tube  
Transmitter Crystal Switch, Plug-in  
2-Meter Simple Superhet

# CHAPTER

3

## THE FABULOUS DIODES

*Throughout the past 11 years, the publishers of POPULAR ELECTRONICS and the ELECTRONIC EXPERIMENTER'S HANDBOOK have presented numerous basic articles on such diverse subjects as transistors, transformers, automotive electronics, CB, etc. The article on the following 16 pages is about germanium and silicon diodes. It is a capsule summary of the numerous applications of diodes, how this new breed of diodes operates, and the strange names they bear. Your Editors would appreciate your comments on articles of this type and votes on whether these articles should or should not appear in the ELECTRONIC EXPERIMENTER'S HANDBOOK in the future.*



**Many electronics experts agree that the usefulness and versatility of the diode will—within another three years—exceed that of the transistor**

**By LOUIS E. GARNER, Jr.**

Since the transistor is only a little over a decade old, many hobbyists—and especially newcomers to electronics—feel that *all* semiconductor devices are quite young. The truth of the matter, however, is that the semiconductor diode is one of the *oldest* of radio-electronic components, predating even the venerable electron tube as a widely used device.

A majority of the early radio receivers employed a crude type of point-contact diode as their detector—essentially, a small piece of galena (a crystalline lead sulphide mineral) to which contact was made with a fine wire dubbed a “cat’s-whisker.” Unreliable, of varying sen-



sitivity, and time-consuming to adjust, this early semiconductor device was widely used, and often cursed. It was, in fact, the search for a superior detector that led to the development of the electron tube.

While the semiconductor diode was eclipsed for a while by the electron tube and, to some extent, fell into disuse and was forgotten, the success of the transistor has brought the device back into its own—but not as the unreliable, finicky, open-air, and ugly galena crystal. Instead, the modern diode comes in thousands of types and styles and is indeed a fabulous creation. Like the phoenix, it has been reborn, but with more vigor, reliability, and versatility. In addition to its ability to detect radio frequencies, the modern diode—in some of its forms—has acquired the additional capabilities of amplification and oscillation.

By definition, a diode is a two-electrode device. However, many modern diodes have three and even four terminal connections. While these multi-electrode devices are still diodes as far as their basic operating characteristics are concerned, the addition of extra electrodes permits the devices to perform some new and, as we shall see later, rather interesting feats of electronic wizardry.

## How Diodes Work

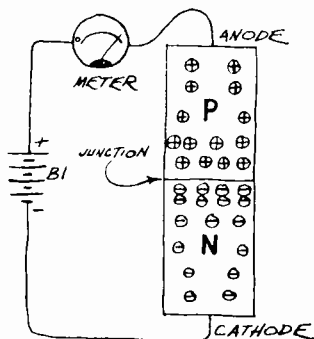

**D**iodes are essentially a junction of *p*- and *n*-type semiconductor materials. The diode derives most of its capabilities from its nonlinear, unidirectional electrical characteristics, i.e., its ability to conduct freely in one direction while acting as a high resistance or open circuit in the opposite direction.

The *p*-type material has a surplus of more or less evenly distributed positive-charged “holes.” The *n*-type material has a surplus of evenly distributed, negative-charged free electrons. Suppose that a battery or other d.c. voltage source were connected in series with the meter and diode, so that a positive voltage would be applied to the *p*-type material and a negative voltage to the *n*-type. Under these conditions, the positive holes would be repelled by the positive voltage and would migrate towards the junction. At the same time, the free electrons in the *n*-material would be repelled and accumulate near the junction.

Thus, a surplus of positive and negative *current carriers* would accumulate at the junction, with a certain percentage “spilling over” into the opposite materials. Holes would migrate into the *n*-type material, where they would be absorbed and become neutralized by the surplus free electrons. At the same time, electrons would enter the *p*-type material, neutralizing holes there. New holes and electrons would be created by the applied d.c. potential and these, in turn, would migrate towards the junction. The result, then, would be a heavy flow of current, as indicated on the meter. The diode, under such conditions, is

said to be biased in its *forward* (or conducting) direction.

Let's consider the opposite situation now. With the battery voltage reversed, the positive holes accumulate at the negative terminal, while the free electrons gather at the positive terminal. The junction region is depleted of current carriers and, therefore, there can be no "carry-over" through the junction. Under these conditions, current flow is very low and the diode acts as a high resistance. It is biased in its *reverse* (or nonconducting) direction.

Going a step further, let's see what happens when the supply voltage is increased with the diode reverse-biased. At this point, we must remember that while there are a *majority* of holes in the *p*-type material there are also a few free electrons present (these are called, appropriately, *minority* current carriers). By the same token, there are a few positive-charged holes in the *n*-type material.

As the electrical pressure (voltage) is increased, these minority carriers start to accumulate in the junction area. Eventually, a certain amount of "carry-over" can take place, and the diode switches rapidly from a nonconducting to a conducting condition. In a way, we can say that the junction has "broken down." The diode current increases very suddenly and, unless there is something to limit current flow (such as a resistor in series with the battery), the diode will be destroyed. The voltage at which this reverse breakdown occurs is called the *zener* voltage.

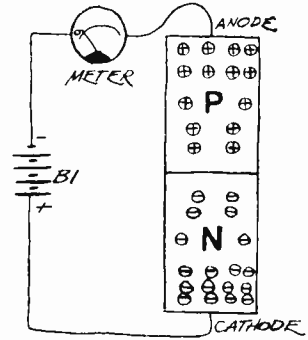

## How They Are Made

Diodes are manufactured using essentially the same techniques that are employed in producing transistors. Thus, we have point-contact, alloyed-junction, grown-junction, mesa, planar, and epitaxial types. (Refer to "Transistors—Types and Techniques," *POPULAR ELECTRONICS*, November, 1962, page 65.) The same types of semiconductor materials are used, including *n*- and *p*-doped germanium and silicon. In addition, some diodes are manufactured of intermetallic and metallic compounds, including copper oxide and sulphides, cadmium sulphide, gallium arsenide, and various selenium compounds.

Physically, small diodes can be mounted in plastic, glass, metal or ceramic cases, while larger types can be assembled on flat plates, on cooling fins, or in electron tube-shaped envelopes. Externally, some may appear to be resistors or capacitors, others look like tiny buttons

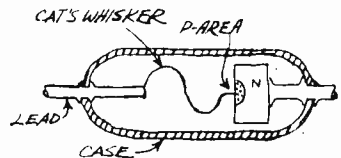

POINT-CONTACT.

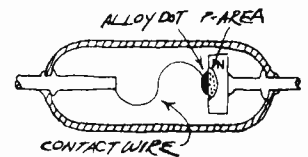

ALLOYED-JUNCTION

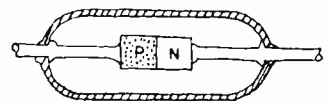

GROWN-JUNCTION

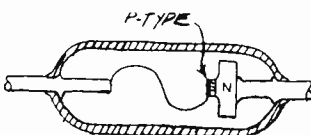

MESA

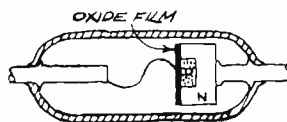

PLANAR

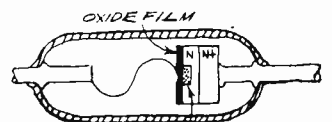

EPITAXIAL

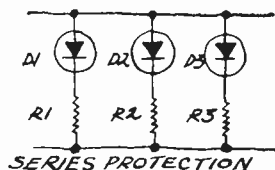
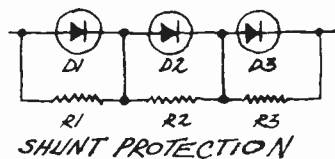
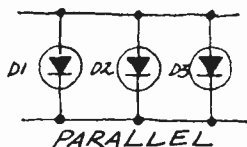

similar to a mercury cell battery, while still others seem to be transistors, for they are assembled in similar cases.

Aside from basic electrical specifications and materials of construction, there are many, many types of diodes. Some are designed for operation in their zener region . . . others are light-sensitive . . . still others have a variable capacitance characteristic. While most are single-junction devices, there are multilayer, multijunction types. Special schematic symbols are used to identify these different types.

Where greater voltage or current handling capability is needed than is available in a single diode, several units can be connected in series or in parallel. The series connection is used where higher voltages must be handled, while the parallel connection is used to increase current carrying ability. A straightforward series or parallel connection can be employed where the individual diodes have virtually identical characteristics. If the diodes' characteristics are not identical, however, the voltage (or current) distribution may be such that one or more of the diodes are destroyed. To avoid this, shunt or series resistors can be employed to equalize voltages (or currents). Shunt resistors are used when the diodes are connected in series, series resistors when the diodes are wired in parallel.

## General-Purpose Diodes

Manufactured of germanium, silicon or selenium, and designed for a broad range of circuit applications, general-purpose diodes are identified by the basic diode schematic symbol. A line represents the cathode, while the anode is identified by an arrowhead. This symbol derives from the original point-contact diode, with the arrowhead indicating the direction of "classical" current flow—just the opposite of electron flow. The general-purpose types include such popular units as the 1N34 (and 1N34A), 1N38, 1N39, 1N56A, 1N58 and 1N66. In practice, the cathode lead is generally identified by a color-band, polarity marking, or similar symbol on the diode's body.

The adjacent diagrams illustrate typical general-purpose diode applications. Almost any general-purpose diode can be used in these circuits, provided the maximum ratings are not exceeded. Low-voltage types may be used in the receiver circuit, while a high-voltage type should be used in the stroboscope.

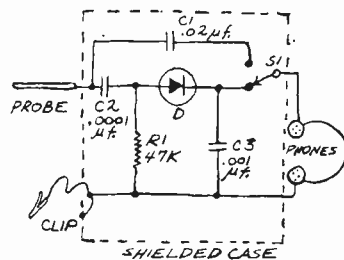
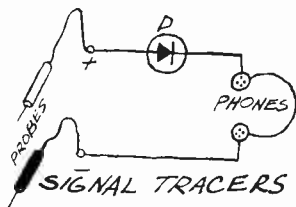
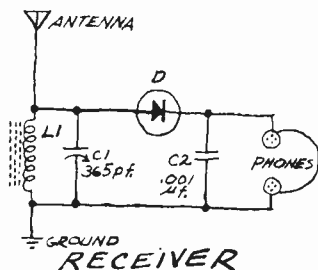
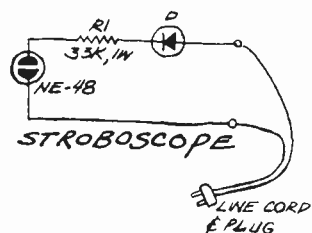

# ZENER DIODES

Physically, low-power zener diodes look very much like general-purpose diodes. In fact, any standard diode can be used as a zener diode. Commercial zener diodes, however, are especially processed and selected for their performance in the zener region. Some zener diodes are manufactured primarily for use as voltage regulators and are so designated. Others are selected for close breakdown voltage tolerance and are referred to as *reference diodes*. Since the zener breakdown, when it occurs, builds up with the suddenness of an avalanche, zener types are sometimes called *avalanche diodes*. Finally, some firms manufacture special zener types which they identify as *Stabistors*.

Zener diodes can be series-connected, either to obtain higher voltage ratings or multiple output voltage. A typical *multi-regulator* circuit consists of an unregulated d.c. source, an adjustable current limiting resistor,  $R_1$ , and a chain of zener diodes,  $D_1$ ,  $D_2$ , etc. In operation, the regulated d.c. voltage available between any pair of output terminals is equal to the sum of the zener diode voltage ratings between the two terminals. For example, if  $D_3$  is rated at 3.6 volts and  $D_4$  at 6.8 volts, 3.6 volts will be available between terminals C and D, 6.8 volts between D and E, and 10.4 volts between C and E.

Zener diodes can be used as an a.c. line regulator. Two diodes are connected "back-to-back." One breaks down on positive line peaks which exceed its rated value while the other breaks down on negative peaks, in both cases dropping the excessive line voltage across the current limiting resistor.

A d.c. voltage regulator circuit is similar to that of the a.c. regulator, except that a single diode is used.

The same principle used in the a.c. regulator can be applied in a simple square-wave generator or clipper. The applied a.c. voltage should be from 10 to 20 times the rated zener breakdown voltage for best action and good, sharp output square-wave signals. The series resistor is large enough to protect the diodes from excessive currents. Used in conjunction with an audio generator, this circuit will provide square waves for checking audio amplifiers.

A voltage-sensitive relay circuit can be used for remote control applications. In operation, the application of a d.c. voltage below either zener diode's breakdown voltage will have no effect. If the voltage is increased until, say,  $D_1$ 's rating is exceeded, relay  $RLY_1$  will close, but relay  $RLY_2$  (assuming  $D_2$  has a higher rating than  $D_1$ ) will remain open. If the voltage is then increased still further, until  $D_2$ 's rating is exceeded,  $RLY_2$  will also close. This circuit is well-suited to applications requiring sequential relay operation with remote voltage control.

Zener diodes can also be employed in meter protection

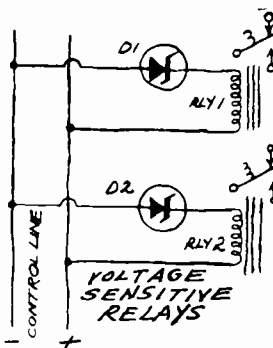
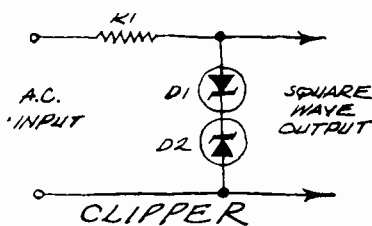
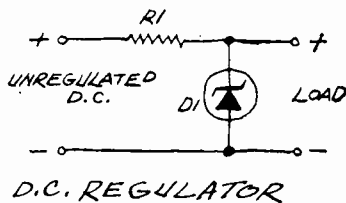
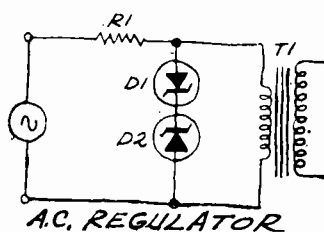
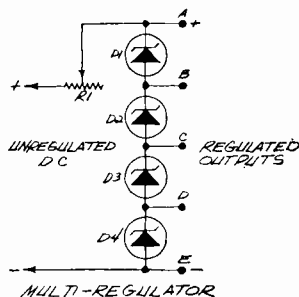

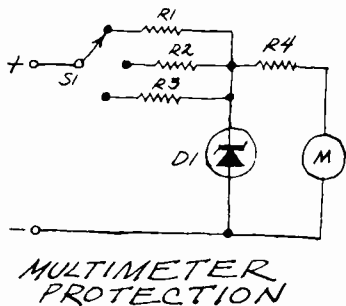

circuits. In the circuit shown here,  $R_1$ ,  $R_2$ ,  $R_3$  and  $R_4$  are the multimeter's multiplier resistors and  $S_1$  is the range switch. The zener diode,  $D_1$ , protects the meter against accidental overload damage. Its rating should be just slightly greater than the voltage required for a full-scale meter reading, but below the meter's maximum rating. Resistor  $R_4$  is chosen so that its resistance, combined with the meter resistance, is considerably greater than the diode's resistance when in a breakdown state.

## DIODE SWITCHES

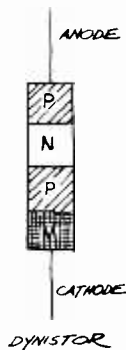
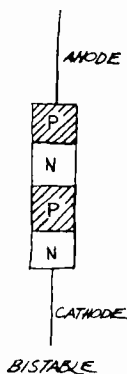

A diode switch is analogous to a mechanical switch in that it has two states—"off" and "on." When in an "off" state, it acts like an open circuit; and when "on," it conducts heavily. In practice, both standard and zener diodes may be used as switches by applying a bias voltage to hold the devices in a nonconducting state, then adding a control signal voltage of sufficient amplitude to cause heavy conduction. There are, however, a whole new class of semiconductor diodes and diode-like devices which are specifically designed for use as switches. Included in this class are the *bistable diode*, *dynistor*, *silicon-controlled switch*, *binistor*, and *double-based diode*.

The *bistable diode* is made up of four alternate layers of *p*- and *n*-type silicon. For this reason, it is also called a *4-layer diode*. In use, the bistable diode does not conduct and remains "off" when biased in its forward direction until the applied voltage reaches a predetermined trigger or "firing" voltage. At this time, the diode switches rapidly into a heavy conducting state, remaining "on" until the applied voltage is dropped to a very low value. When reversed-biased, it behaves very much like a conventional diode, acting as an open circuit until its zener breakdown voltage is reached. (See diagram below.)

Somewhat similar to the bistable diode, except that its basic material is germanium and its fourth layer is metallic rather than *n*-type semiconductor material, is the *dynistor*. The dynistor's forward characteristics are essentially similar to those of the bistable diode, but the unit does not block reverse current flow.

The *silicon-controlled switch* (SCS) is a four-layer device closely resembling the bistable diode, but with an electrical connection made to the third layer. A small "trigger" voltage applied to this electrode, called a *gate*, will switch the device from a nonconducting to a conducting state quite rapidly, even though the cathode-anode voltage is below that normally required to trigger. Several versions of this device are offered by various manufacturers. In its basic form, the SCS can only be switched "on"

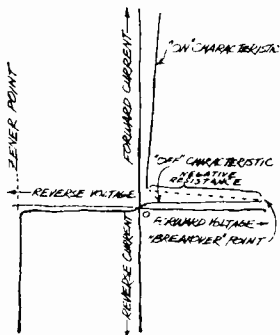

by a gate signal . . . afterwards, it can be returned to its stable "off" state only by dropping the anode-cathode voltage to a low value. Slightly modified forms which can also be switched off by the application of a reverse bias to the gate are called *Trigistors* (Clevite-Shockley) and *Transwitches* (Transitron). A germanium version of the device is called a *Dynaquad* by its manufacturer (Tung-Sol).

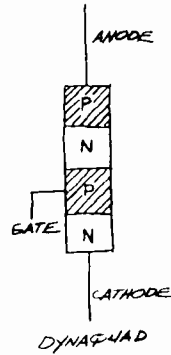

It is possible, of course, to provide an electrical connection for the second as well as the first, third and fourth layers in a four-layer device. In this case, we have another gate electrode and, to differentiate between the two gate connections, the one nearest the anode is called the *anode gate* ( $G_A$ ), while the one nearest the cathode is termed the *cathode gate* ( $G_C$ ).

One manufacturer of the four-layer, four-connection "diode" suggests that the anode gate connection be used as an output terminal. The device is then called a *binistor*, and new designations are assigned to each of the electrodes. The anode is called an *injector*, the anode gate a *collector*, the cathode gate a *base*, and the cathode the *emitter*.

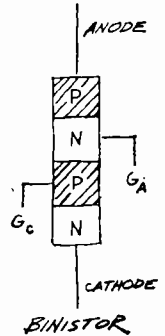

At right is a generalized characteristics curve applicable to the whole "family" of four-layer diodes (except for the dynistor, which conducts when reverse biased). These devices do not conduct appreciably in either their forward or reverse direction until either their zener voltage is exceeded (in reverse bias mode) or their trigger or forward "breakover" point is reached. Once the breakover voltage is attained, the devices switch rapidly to a heavily conducting state, acting as low resistances even at low voltages. The effect of a trigger applied to a control gate is to reduce the anode-cathode voltage point at which breakover occurs. In effect, then, these four-layer switches have three forward states—an "off" state in which they do not conduct, a *transition* state during which they exhibit a negative resistance characteristic, and an "on" state in which they conduct heavily.

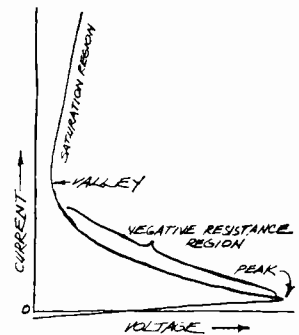

There is yet another diode switch, different in construction from the class of four-layer devices we've just discussed—the *double-based diode*, now more popularly known as the *unijunction transistor* (or UJT). This device consists of a bar of *n*-type germanium or silicon with ohmic contacts at each end, designated *Base 1* ( $B_1$ ) and *Base 2* ( $B_2$ ), and a *pn* junction slightly off-center. If  $B_2$  is made positive with respect to  $B_1$ , the emitter- $B_1$  junction behaves like a high value resistor . . . up to a point. If sufficient voltage is applied to the emitter- $B_1$  junction, the device will switch suddenly from a high resistance to a low resistance (virtually a short circuit) state, passing quickly through a negative resistance transition region.

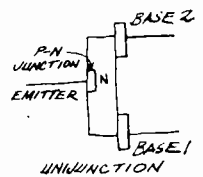

A *relaxation oscillator* circuit employing a bistable diode is shown at right. In operation, the voltage applied by

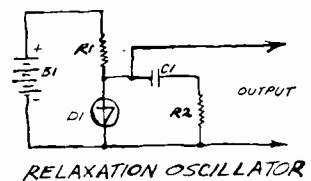

the d.c. source ( $B1$ ) charges the capacitor ( $C1$ ) through series resistors  $R1$  and  $R2$ . The bistable diode,  $D1$ , remains in an "off" or nonconducting state until the capacitor voltage reaches the diode's trigger voltage, at which time the diode switches to a low-resistance conducting state and discharges the capacitor through its internal resistance and  $R2$ . Then the action repeats itself. In general, the battery voltage is considerably greater than the diode's trigger voltage. Resistor  $R1$  is much larger than  $R2$ . Both  $R1$ ,  $R2$ , and  $C1$ , are chosen so that their combined time constant is appropriate to the repetition rate (frequency) desired.

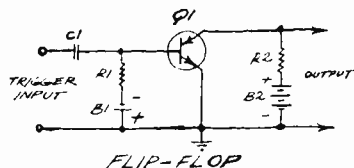

The flip-flop circuit shown here is similar to those used extensively in computers. A controlled switch such as a Tristor or Transwitch might be used ( $Q1$ ). In operation,  $Q1$  is normally in a nonconducting or "off" state, and full battery ( $B2$ ) voltage appears at its upper terminal. If a positive pulse is applied to the device's gate through blocking capacitor  $C1$ , the device switches to a heavily conducting state, dropping  $B2$ 's voltage across the load resistor,  $R2$ , and developing a negative output pulse. The device remains "on" until a negative pulse is applied through  $C1$ , at which time it reverts to the original "off" state, developing a positive output pulse. Battery  $B1$  applies a fixed gate bias to the device through  $R1$  to insure stable operation.

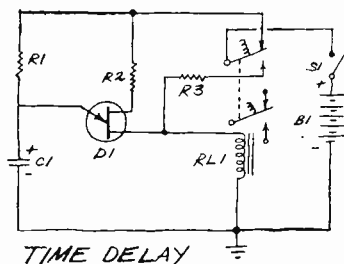

A time-delay relay using a unijunction transistor is at left. The relay closes a specified period of time after  $S1$  is closed, and then remains closed until  $S1$  is opened to "reset" the circuit. A simple  $RC$  time constant network is formed by  $R1$  and  $C1$  to furnish the delayed emitter voltage which "fires" the UJT. Base 2 voltage is furnished through  $R2$  and, of course, the upper relay contacts. Once the UJT fires, the relay is pulled in, removing the emitter and base 2 voltages and applying a "holding" voltage to the relay coil through  $R3$ . The second set of relay contacts is used to actuate an external circuit.

## PHOTODIODES

Nearly all semiconductors are sensitive to light. When light strikes the surface of the material, electrons are freed from their valence bonds and, in some cases, positive-charged holes are created. Under the proper conditions, enough electrons may be released so that a small voltage develops. This has led to the development of a large group of light-sensitive semiconductor diodes—or *photodiodes*.

Commercial photodiodes may be divided into three

broad groups—*photoresistive* devices, *photovoltaic* devices, and *light-activated switches*.

*Photoresistive* diodes have a resistance inversely proportional to the amount of light falling on their sensitive surface—the stronger the light, the lower their resistance. Any of the standard semiconductor materials, including germanium, silicon, and selenium, can be used for their manufacture, but a good many are made with semiconductor compounds such as cadmium sulphide.

*Photovoltaic* diodes (“sun batteries”) generate a d.c. voltage when light falls on their surface. In general, the amplitude of the voltage developed is proportional to the intensity of the light, up to a maximum fixed by the type of material used in construction, while the amount of current that can be delivered is proportional to the unit’s exposed sensitive area. Most present-day photovoltaic diodes use either silicon or selenium as their basic material.

*Light-activated switches* are similar to four-layer diode switches, except that they are mounted in a transparent glass (or partial glass) enclosure to enable light to reach the junction area. Their operation is similar to that of diode switches, too, but with the gate trigger signal replaced by light energy. The *Photran*, a unique type, has an electrical connection provided for the normal gate terminal, resulting in a three-electrode light-sensitive device.

The semiconductor *laser* is a special type of “photodiode” which *emits* light. Typically, these units are made of intermetallic compounds. Such a device may consist of a small *pn* junction of gallium arsenide with the front and back faces cut perfectly parallel to each other perpendicular to the junction plane and highly polished. When heavy current pulses are passed through the device, intense coherent light is emitted perpendicular to the polished surfaces along the *pn* junction. Typical pulse currents may run as high as 20,000 amperes per square centimeter. Electrical-to-light energy diode converters of this type are nearly 100 per cent efficient. The emitted light, for a gallium arsenide diode, is in the infrared region.

The standard *photographic light meter* circuit at right is basically just a photovoltaic diode connected to a sensitive microammeter. The meter scale may be calibrated either in terms of foot-candles or in camera shutter/iris settings.

The *automatic light switch* consists of a photoresistive diode connected in series with a sensitive relay and a d.c. power source. As long as there is sufficient light on the diode, its resistance is kept low and it passes sufficient current to hold the relay closed. When darkness falls, the diode’s resistance increases, reducing relay coil current and allowing the relay to drop out, closing the lamp contacts.

Another photographic instrument circuit is a remote *slave flash*. A light-activated switch is connected in series

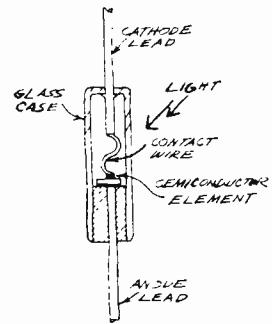

LIGHT ACTIVATED

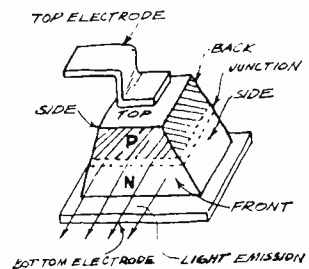

LASER

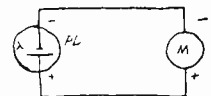

LIGHT METER

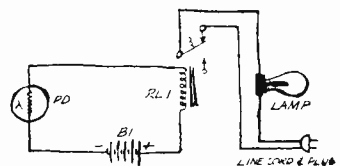

LIGHT SWITCH



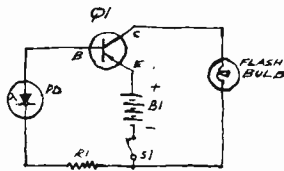

SLAVE FLASH

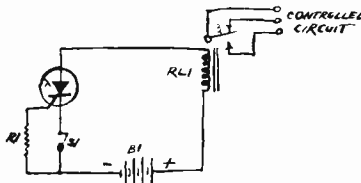

LOCK-IN RELAY

with a current limiting resistor ( $RI$ ), a power source ( $BI$ ), and a power transistor's base-emitter circuit. In operation, light from the main flash triggers the photodiode, causing it to fire and applying a heavy base current to the transistor. The transistor, in turn, conducts heavily, firing the flash bulb. The power switch,  $SI$ , must be open before a new bulb can be inserted.

A lock-in relay uses a Photran with its gate biased by means of  $RI$ . In operation, the relay remains open until light strikes the Photran's sensitive surface. When this happens, the Photran switches to a conducting state, closing the relay. The relay then remains closed until the power circuit is interrupted (by opening  $SI$ ). This general type of circuit might be used as an automatic switch for, say, a darkroom, or in alarm applications.

## TUNNEL DIODES

Sometimes called the *Esaki diode* in honor of its Japanese inventor, the tunnel diode is an extremely versatile device. It is capable of being used as a detector, amplifier, or oscillator, is extremely efficient and, in some types, is useful at frequencies up to 10,000 megacycles or more.

Manufactured from standard semiconductor materials such as germanium as well as from intermetallic compounds such as gallium arsenide, the tunnel diode is basically a  $pn$  junction, but with the junction depletion region made very thin. The result is that the device is essentially in a "reverse breakdown" condition even when a small forward bias is applied. As the bias is increased, there is an increase in current, up to a point. As the reverse breakdown condition is neutralized, the diode's current *decreases with increasing voltage* until a valley point is reached—afterwards, the tunnel diode behaves much like a conventional diode. A decrease in current with increasing voltage is the basic characteristic of a *negative resistance* (as distinguished from a "positive" resistance, in which current increases as applied voltage is increased). It is this characteristic (negative resistance) which makes the tunnel diode useful as an oscillator.

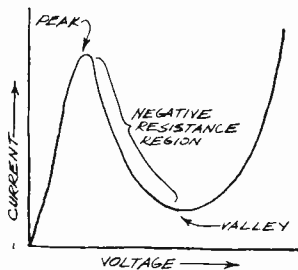

In a conventional semiconductor device, the current carriers move rather slowly, diffusing through the crystalline structure of the material. In a tunnel diode, the current carriers (electrons, for example) traverse the junction area at what appears to be the speed of light. In effect, when an electron enters the junction, another suddenly appears at the other side, much as if there were a "tunnel" through the junction area (hence the device's name).

A practical *FM wireless microphone* based upon a circuit suggested by GE, is shown below. The resistors are all half-watt units, while *C3* and *C4* are electrolytic capacitors, *C2* a small ceramic disc unit, and *C1* a tiny air variable capacitor. Coil *L1* consists of six turns of No. 16 wire, air-spaced  $\frac{3}{8}$ " in diameter. The antenna is a  $\frac{43}{4}$ " length of No. 14 wire, and the microphone is a Shure Brothers No. 426 or equivalent.

The tunnel diode serves as an oscillator in conjunction with tuned circuit *L1-C1*, with its d.c. operating voltage supplied by voltage divider *R1-R2*. The audio signal obtained from the microphone is amplified and superimposed on the d.c. voltage through coupling capacitor *C3*. This varies the tunnel diode's instantaneous supply voltage in accordance with the audio signal, frequency-modulating the r.f. signal developed by this device.

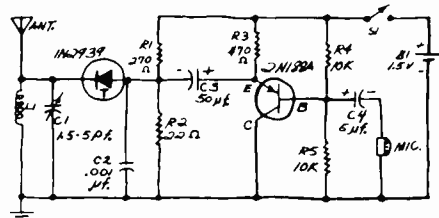

FM WIRELESS MICROPHONE

## CAPACITOR DIODES

The application of reverse bias to a junction diode will cause the junction area to be depleted of current carriers (electrons and holes) and thus act as a high resistance, insulator or dielectric. There is still an electrical capacitance between the *p* and *n* areas, however. This characteristic of the semiconductor diode has led to the development and production of a variety of voltage-variable semiconductor capacitors. These devices are identified by a variety of names, including *varactor* (for *variable reactor*), *Semicap* and *Varicap*.

The operation of a varactor is easily understood. If a semiconductor diode junction is reverse-biased, the central junction area is depleted and acts as an insulator (dielectric). There is always an interelectrode capacity between the *p* and *n* areas. As the reverse bias is increased, the depletion layer expands, reducing the interelectrode capacity. Conversely, as the reverse bias is decreased, the depletion layer shrinks, increasing capacity. Maximum capacity is obtained when the device is operated at zero bias.

Commercial varactors can be made of germanium or silicon and are generally specified in terms of *maximum working voltage*, *capacitance* (at a specific voltage), and typical "Q." The latter characteristic indicates the "quality" of the device and is obtained by dividing its reactance

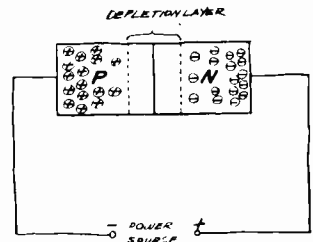

VOLTAGE-VARIABLE DIODES

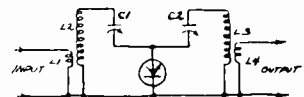

FREQUENCY DOUBLER

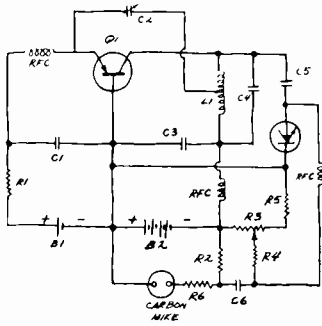

FM WIRELESS MICROPHONE

(in ohms) by its equivalent series resistance (in ohms). A  $Q$  may range from less than 5 to 100 or more.

In practice, varactors are used for electrical tuning in circuits such as the basic *frequency doubler* shown on page 77 or the *FM wireless microphone* at left.

## POWER DIODES

**P**ower diodes are basically similar to small signal diodes. They are manufactured of the same materials, have similar characteristics, and, in general, are produced using the same construction techniques. The chief differences between power and small signal diodes, then, lies in their physical size and actual specifications. Power diodes have larger junction areas in order to pass heavier currents and, in some types, have thicker junctions to permit them to handle high voltages without breakdown. At the same time, the larger junctions mean greater interelectrode capacities and hence limited high frequency capabilities.

As do their smaller cousins, power diodes conduct heavily when biased in the forward direction and block current flow when biased in their reverse direction. Their forward and reverse resistances are likely to be lower than small signal types with, of course, correspondingly higher forward and "leakage" currents. Power diodes are rated and specified in the same general terms as are applied to small signal types—typically, maximum forward current, nominal reverse current, nominal reverse voltage, and peak inverse voltage (PIV).

## Rectifier Diodes

**D**esigned primarily for use in a.c.-to-d.c. power supplies, power rectifiers can be manufactured of selenium, germanium, or silicon. A few types are made using copper oxide, copper sulphide, and various magnesium compounds, but these have been largely supplanted by the former types. Since they are intended primarily for power supply use, some types may be specified in terms of *maximum a.c. input voltage*, *output d.c. volts* and *current* rather than in the more general terms mentioned above.

In a *half-wave rectifier* using a single diode, the PIV is twice the output d.c. voltage or 2.83 times the a.c. input voltage with a capacitive input filter under "no load" conditions; the nominal d.c. output is 1.41 times the r.m.s. (a.c.) input voltage. The ripple frequency (which must be

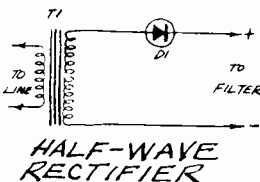

HALF-WAVE RECTIFIER

removed by the filter circuit used) is equal to the line frequency.

The *full-wave rectifier* requires a center-tapped source (such as the transformer secondary) and uses two diodes. Under the conditions described above, the PIV is twice the output d.c. voltage or 2.83 times the r.m.s. (a.c.) input voltage, while the nominal d.c. output is 1.41 times the a.c. voltage from half the secondary winding. The ripple frequency, in this case, is twice the line frequency.

A center-tapped source is not required for the *full-wave bridge rectifier*, but four diodes are used. Here, the PIV is equal to the d.c. output voltage and is 1.41 times the r.m.s. (a.c.) voltage supplied by the transformer's secondary winding.

The *voltage doubler* supplies an output d.c. voltage which is twice the peak input voltage—or 2.83 times the r.m.s. (a.c.) input voltage. The PIV is equal to the d.c. output. In operation, diode *D1* conducts on one half-cycle, charging *C1* to the peak supply voltage. On the next half-cycle, *D2* conducts, charging *C2* to the peak supply voltage. The two capacitors (*C1* and *C2*) are discharged in series through the filter to the load.

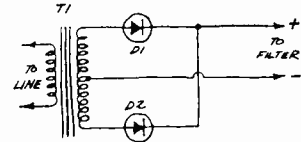

FULL-WAVE RECTIFIER

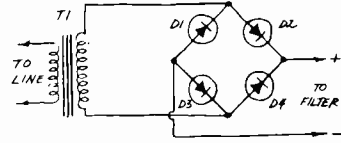

BRIDGE RECTIFIER

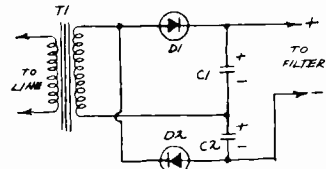

VOLTAGE DOUBLER

## Silicon Controlled Rectifiers

The *silicon controlled rectifier*, or SCR as it is commonly called, is a "big brother" version of the silicon controlled switch (SCS). It is a four-layer semiconductor device with an "all or nothing" characteristic. When forward-biased, it does not conduct until its breakover voltage is reached unless it is triggered by a control signal applied to its gate electrode; afterwards, it conducts heavily and will continue to conduct until its anode-cathode voltage is dropped to a low value. When reverse-biased, the SCR blocks current flow until its zener voltage is exceeded and junction breakdown occurs.

Most SCR's have the gate connection made to the third layer of the four *pn* layers making up the device. Those SCR's with a *cathode gate* are identified by the schematic symbol shown at left below while a few types are equipped with an *anode gate* (at right below) and are identified by a slightly different symbol.

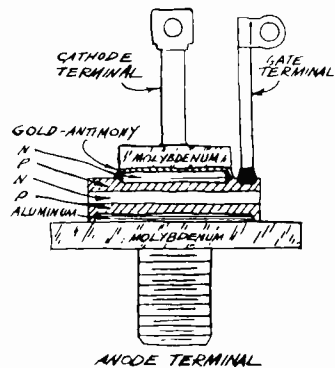

SILICON CONTROLLED RECTIFIER

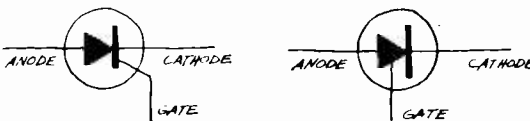

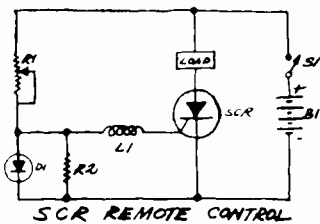

Commercial SCR's are sold in sizes with current ratings of less than 1 ampere to well over a hundred amperes, and with voltage ratings up to 500 volts or more. While standard SCR's can be turned "on" by the application of a trigger signal to their gate—and "off" only by dropping or reversing the anode-cathode voltage, there are several new types which can be turned "off" by the application of a reverse bias trigger to their gate.

A remote control SCR circuit is shown at the left. In this circuit the gate is biased just below its firing point by voltage divider  $R1$  and  $R2$ . Diode  $D1$  is included for temperature compensation. A radio signal from a nearby transmitter, picked up by antenna coil  $L1$ , "fires" the SCR, actuating the *Load*, which might be, as an example, a motor in a toy.

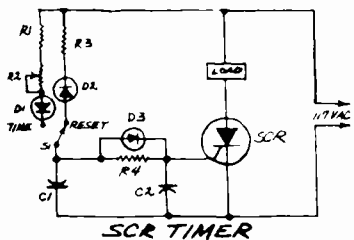

This timer circuit is designed for operation on a standard a.c. line. When the control switch,  $S1$ , is turned to its "TIME" position,  $C1$  is charged through  $D1$ ,  $R1$  and  $R2$ . When sufficient voltage is built up across this capacitor, the SCR is triggered, supplying power to the load device. Potentiometer  $R2$  sets the time delay, which is a function of the  $R1/R2/C1$  time constant. The circuit is reset by turning  $S1$  to the "RESET" position, which discharges the capacitor and applies a reverse voltage to the gate. The SCR, of course, stops conducting on alternate half-cycles. Although a polarized capacitor is shown for  $C1$ , this normally would be a large-value metalized paper unit.

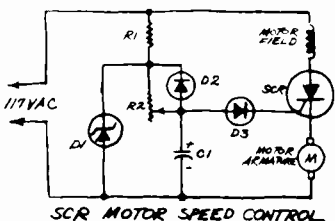

You can use an SCR to rectify line voltage and power a d.c. motor—while furnishing control over motor current in this motor speed control circuit. The motor speed adjustment control is  $R2$ , while the zener diode,  $D1$ , stabilizes the gate voltage. The point at which the SCR "fires" on alternate a.c. half-cycles is determined by its gate voltage. If  $R2$  is set for maximum voltage, the SCR conducts over virtually an entire half-cycle, supplying maximum power to the motor's field and armature windings. If  $R2$  is set for minimum voltage, the SCR conducts only during the last half of each alternate half-cycle, or for a quarter-cycle, supplying minimum power to the motor.

## SURGE SUPPRESSORS

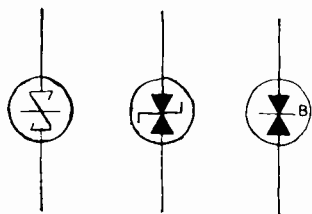

Electrical circuits, whether operated on a.c. or d.c. voltages, are often plagued by transient voltage peaks or surges, either externally or internally generated. Silicon and germanium semiconductor devices are especially sensitive to surge voltages, and a high-voltage transient or "spike" can destroy a semiconductor junction. Manufacturers have introduced special semiconductor devices to guard against and suppress transients. Most of these devices are made

up by connecting a suitable pair of selenium zener diodes back-to-back and are identified by a variety of trade names, depending on the manufacturer, including *Voltrap*, *Thyrector*, *Klip-Sel*, and *Silgard*.

Typical surge protector applications are illustrated here. A single unit is used in one circuit to protect the a.c. voltage supplied to a load by a transformer. A pair of units are frequently used in a full-wave rectifier to protect the rectifier diodes against transients. Circuit operation is similar in both cases. Under normal conditions, the surge suppressors act as open circuits, since one or the other of the two diode elements making up the device is always reverse-biased. If a transient voltage spike or surge occurs which exceeds the device's rating, the unit goes into zener breakdown, shorting out the surge.

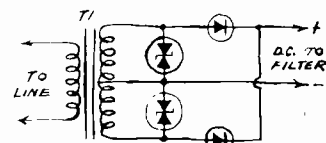
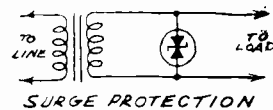

FULL WAVE SURGE PROTECTION

## THERMOELECTRIC DIODES

Although not a "diode" in the classical sense, the thermoelectric diode is a thermocouple-type device with a variety of applications. It consists of *p*- and *n*-type semiconductors bonded together by copper or similar high-conductivity metal. Straps are connected to the opposite ends of the semiconductor bars for electrical connections and the two ends of the bars are thermally insulated.

If the connection straps are attached to an insulated heat sink and heat is applied to the sides of the semiconductors which are bonded together, the electrons and positive holes in the *n*-type and *p*-type semiconductors, respectively,

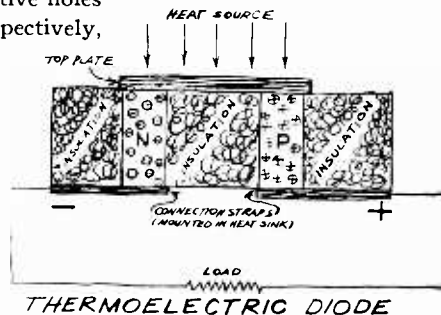

undergo thermal diffusion from the high- to the low-temperature side, developing a potential difference. This voltage can be used as an effective power source for a standard electrical load as long as a temperature difference is maintained between the two sides of the device. Thus, the unit becomes a heat-to-electrical energy converter.

The output voltage supplied by a single element is relatively small, and commercial thermoelectric generators generally are made up of a number of elements in a series-parallel arrangement to obtain usable voltages at fairly

high currents. The 3M Type 18A thermoelectric generator is a typical unit: it can supply up to 15 watts—3.5 volts at 4.3 amperes—while consuming 0.15 lb. of propane fuel per hour.

Essentially the same type of thermoelectric diode can be used in a different manner. If power is *applied to the device* by an external d.c. source, with the negative terminal of the power supply connected to the *p*-type semiconductor and the positive terminal connected to the *n*-type material, the top plate becomes cool and the lower connectors warm. In effect, the device absorbs heat at one end and releases it at the other and becomes a type of electronic *heat-pump*.

Commercial thermoelectric heat-pumps of this general type are used in the manufacture of motorless refrigerator and air-conditioning units and as "spot coolers" for high-power transistors, diodes, SCR's, and similar semiconductor devices. One firm identifies its line of thermoelectric cooling elements as *Frigistors*.

## SPECIAL DIODES

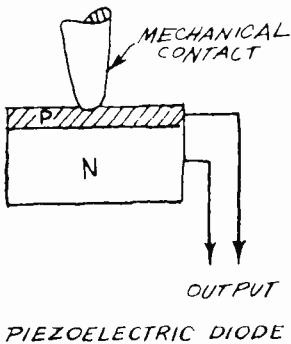

While the diodes described on the preceding pages constitute the overwhelming majority of commercially available semiconductor diodes, there are a number of important special-purpose units. Most are experimental, but are expected to be useful in the very near future.

The *piezoelectric* diode is one that is currently under development. It consists of a *pn* junction to which a mechanical pressure contact is made. The junction's resistance (and hence its effective output) is proportional to the mechanical pressure exerted. Undoubtedly, piezoelectric diodes will have potential applications in microphones, hi-fi phono cartridges, and vibration pickups.

## THE FUTURE

As we have seen, the semiconductor diode is one of the most versatile of simple electronic components. It has, today, more applications than the proverbial dog has fleas. If past performance is any criteria, we can expect many new applications in the future—and many new types of semiconductor diodes. Of the various experimental types now being tested, the semiconductor *laser*, the tunnel diode (and its first cousin, the "camel" diode), and the thermoelectric "diode" hold the greatest promise for startling future developments. But even the best of prophets can be wrong. A completely new type of semiconductor diode may even now be in the development stages in our nation's research laboratories!

# SOMEONE SHOULD DEVELOP AN EASY WAY TO LEARN ELECTRONICS AT HOME

## RCA INSTITUTES DID!

RCA introduces new CAREER PROGRAMS—beginning with the student-proved "AUTOTEXT" Programmed Instruction Method—the faster, easier way to learn. You start to learn the field of your choice immediately. No previous training or experience needed.

Pick the career of your choice—and RCA Institutes will do the rest! RCA's new, revolutionary "Career Programs" help you go directly to the career you want! You waste no time learning things you'll never use on your job! Each Career Program is designed to get you into the kind of job you want in the fastest, easiest possible way!

### SEPARATE COURSES

In addition, in order to meet specific needs, RCA Institutes offers a wide variety of separate courses which may be taken independently of the above Career Programs, on all subjects from Electronics Fundamentals to Computer Programming. Complete information about these courses will be sent with your other materials.

**CHOOSE A CAREER PROGRAM NOW**  
your first step to the job of your choice!

- Television Servicing
- Telecommunications
- FCC License Preparation
- Automation Electronics
- Automatic Controls
- Digital Techniques
- Industrial Electronics
- Nuclear Instrumentation
- Solid State Electronics
- Electronics Drafting

### RCA INSTITUTES BONUS EXTRAS

Only RCA Institutes offers you a Liberal Tuition Plan, one of the most economical ways to learn. Plus, you get top quality equipment in all kits furnished to you with your courses—yours to keep and use on the job. And now, RCA's NEW PROGRAMMED ELECTRONIC BREADBOARD GIVES YOU LIMITLESS EXPERIMENTATION—scientific laboratory procedures

right in your own home! You build a working signal generator, AM Receiver, Multimeter, Oscilloscope, and other valuable equipment—ALL AS A PART OF YOUR COURSE! Get the facts today!

Classroom Training Also Available. Day and Evening Classes are available to you in New York City at RCA Institutes Resident School. You may be admitted without any previous technical training; prep courses are available if you haven't completed high school. Coeducational classes start four times a year.

**SEND ATTACHED POSTCARD TODAY FOR COMPLETE INFORMATION. NO OBLIGATION. NO SALESMAN WILL CALL. FREE BOOK INCLUDED. CHECK HOME STUDY OR CLASSROOM TRAINING.**

**RCA INSTITUTES, INC.** Dept. EE-95

A Service of the Radio Corporation of America  
350 West 4th St., New York City 10014



The Most Trusted Name in Electronics

CIRCLE NO. 24 ON READER SERVICE CARD



NOW YOU CAN EASILY ADD  
SOUND TO YOUR SLIDE  
OR FILM SHOWS WITH  
POPULAR PHOTOGRAPHY'S  
EXCITING NEW  
"SOUND FOR A  
PICTURE EVENING"

RECORD ALBUM

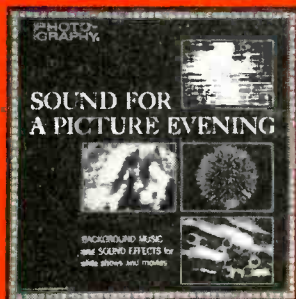

"Sound For A Picture Evening"  
Consists of selections from the music masters  
of the Capitol Record Hollywood Library  
High Fidelity 12 Inch vinyl album—33 1/3 RPM  
Playing time: 40 minutes  
AVAILABLE IN MONAURAL OR  
ELECTRONIC STEREO AT NO EXTRA COST

EXPRESSLY CREATED FOR FILM  
AND SLIDE SHOWS

No matter how good your film and slide shows are, sound will make them better...more entertaining and certainly more professional. But, it has to be the right kind of sound. Although any musical record can be used as a background for your film and slide shows, few, if any, can match the variety of actions, situations, and scenes inherent in most shows. That's why Popular Photography created this album. It's ideal for almost every mood captured by your camera. Whether your show is simple, elaborate or somewhere in-between—"SOUND FOR A PICTURE EVENING" provides a final, professional touch to make it a complete success.

A POPULAR PHOTOGRAPHY  
EXCLUSIVE

The "Sound For A Picture Evening" album has been produced by the editors of Popular Photography exclusively for our readers and is prepared by the Custom Services Division of Capitol Records. This outstanding album can not be purchased in any store and is available by mail only to the readers of Popular Photography and other Ziff-Davis magazines.

ALBUM CONTENTS:  
17 SPECIFIC MOOD MUSIC  
BACKGROUNDS  
8 TRACKS FOR SPECIAL  
SOUND EFFECTS

THEMES TO MATCH YOUR  
SUBJECTS... PERFECTLY!

3 FILM OPENINGS: Grandiose, Sweet and Gentle and Dramatic • 3 FILM CLOSINGS: Epic Finale, Hollywood Style and Gentle • 11 THEMES: Happy-Go-Lucky • Gay Part • Vacation Tempo • Traveling • Happy Birthday Part • Pomp of a Parade • Sound of a Carousel • Circus Time • Sentimental Moments • Children's Play time • Christmas Time

DON'T MISS OUT ON THIS OUTSTANDING OFFER.  
FILL IN AND MAIL TODAY

FOR SPECIAL SITUATIONS,  
THESE WONDERFULLY REALISTIC  
SOUND EFFECTS

Ocean Waves • Train • Jet Planes • Baby Crying • Crowd  
in Stadium • Traffic • Dog Barking • Thunder And Rain

FREE! WITH YOUR ALBUM  
PURCHASE — IF YOU ORDER NOW

Complete Instruction Booklet—Here, in one comprehensive booklet, is all the information you need to make your film or slide show a resounding success. You will find helpful tips on how to build an effective sound track, choosing the right background selections and sound effects, synchronization, taping, organizing your show, editing and much more.

BAND POINTER—Fits on the top of your record and tells you where to find the exact band you want. Eliminates guesswork, fumbling and wasted time. Lights • Projector • Action

This wonderful 12" long-playing album  
(a must for every slide and film show impresario)  
can be yours for

ONLY \$3.49 POSTPAID  
MONAURAL OR ELECTRONIC STEREO

... a small price to pay for an album you will enjoy  
and treasure for many years. ORDER NOW.

"Sound For A Picture Evening"  
POPULAR PHOTOGRAPHY—Dept. SD  
One Park Avenue, New York, N.Y. 10016

Please send me \_\_\_\_\_ albums at \$3.49 each. My  
check (or money order) for \$\_\_\_\_\_ is enclosed. I  
understand that you will pay the postage. (Add 75¢ to  
partially defray postage costs outside U.S.A.)

CHECK ONE: MONO  STEREO

Name \_\_\_\_\_

Address \_\_\_\_\_

City \_\_\_\_\_ State \_\_\_\_\_ Zip Code \_\_\_\_\_

Sorry—No charges or C.O.D. Orders EEH-65

# CHAPTER

4

## SCIENCE FAIR PROJECTS

*Each year tens of thousands of high school and junior college students enter "Science Fair" contests. Originated to encourage more interest in science at school levels, the "Science Fair" has gradually become a highly competitive event with prizes worth hundreds and even thousands of dollars. Electronics has always played a prominent role in "Science Fairs"—partially because of the space-age interest, and partially because of the visual effects that electronics projects offer to the public.*

*For this portion of the Fall 1965 ELECTRONIC EXPERIMENTER'S HANDBOOK, the Editors have selected three "Science Fair" projects that are sure winners. In each story all of the necessary construction details are presented to make the project operative, but only a minimum of background theory is included. This presentation is in keeping with the philosophy of "Science Fairs" in that the student must analyze the subject matter and then demonstrate his findings.*

*The "Repulsion Coil" project on page 88 demonstrates the principle of resonance using 60-cycle house current. Two visual effects offered by this project are a reciprocal resonant engine and a magnetic gun. The "Big TC" Tesla Coil (page 93) has been a "Science Fair" winner since its original appearance in the July 1964 issue of POPULAR ELECTRONICS. This article has been brought up to date and, as can be seen in our cover photo, the spark output greatly increased. Extra safety precautions have been incorporated in the revised circuit. A small Tesla coil using commonly available TV components is shown on page 99. This "Li'l TC" can be used to demonstrate brush discharges from high-frequency, high-voltage power supplies, or even to spin a near-weightless aluminum vane.*

88

**A 60-CYCLE REPULSION COIL-RESONANCE ENGINE**

Walter B. Ford

93

**BIG TC** ..... Charles Caringella, W6NJV

99

**LI'L TC** ..... Edwin N. Kaufman

# A 60-CYCLE REPULSION COIL RESONANCE ENGINE

By WALTER B. FORD

*Startle your friends with this dynamic demonstration of low-frequency resonance and other dramatic a.c. effects. This Science Fair project works on ordinary 60-cycle house current*

**N**EARLY EVERY electronics experimenter is familiar with the process of adjusting a circuit to resonate at a specific radio frequency—you do this every time you tune in your favorite radio or TV station. Much more mysterious and surprising, however, are resonant circuits operating at the low 60-cycle frequency of our home lighting circuits. The repulsion coil—resonant engine described here reveals some of the secrets of this fascinating phase of electronics and provides a unit that can be used for a number of exciting experiments.

The values and dimensions given here are from the author's working model, and while they may be varied somewhat, changes of any kind are not recom-

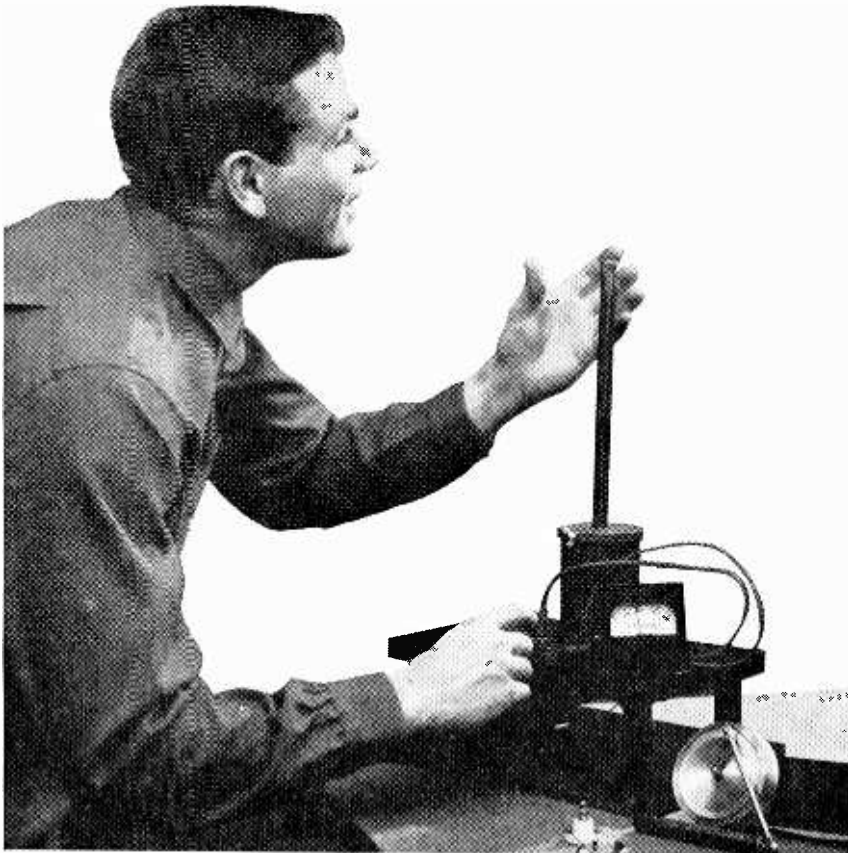

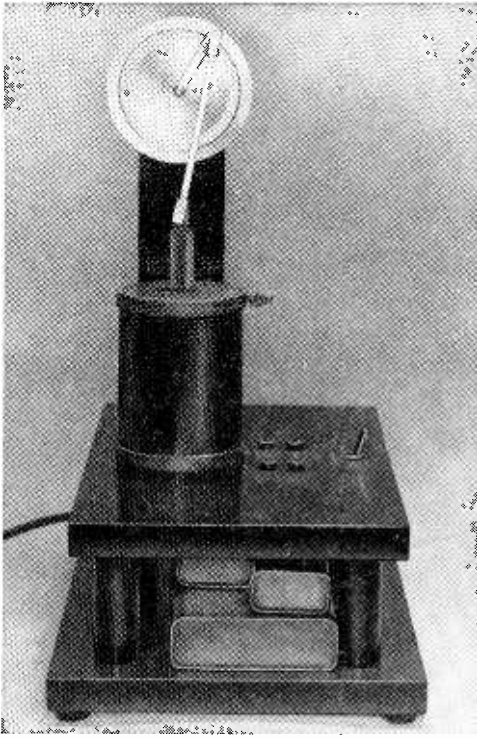

Constructed on a black lacquer wooden base, the resonant-coil engine is an impressive-looking unit.

mended unless the experimenter understands what effect the changes will have on the operation of the unit. If, for example, capacitors of lower value are used, the stroke of the engine piston will change. This will mean that there will have to be a proportionate change in the length of the flywheel crank.

**Making the Coil.** The inductive part of the series-resonant *LC* circuit used in the unit is in coil *L1*. Begin by making up a coil form as shown in Fig. 1 (page 90). Although plain wood discs may be used for the ends, plywood, fiber, or Micarta is preferred, since there is less chance of breakage if the coil is accidentally dropped. The center tubing can be Micarta, Bakelite, or fiber, or can be made by drilling a  $\frac{5}{8}$ " hole lengthwise in a piece of  $\frac{3}{4}$ " dowel rod. Whichever material is used, make sure the inside surface is smooth, sanding if necessary, so the engine piston will travel freely.

Complete the coil form by drilling holes in the end discs that make a snug fit around the center tubing, and gluing

the ends and tubing together with epoxy glue. This step is important because there will be considerable pressure against the ends when the wire is in place on the coil. Drill  $\frac{1}{16}$ " holes through one end of the coil form for the coil leads as indicated in Fig. 1. Drill and tap two holes for 6-32 machine screws in the same end of the form to hold the completed coil to its base (if wood is used, wood screws can be used and the threaded holes will not be needed). Wind the coil form with  $2\frac{1}{2}$  pounds of 24-gauge magnet wire. While it is not necessary to wind the coil perfectly, like thread on a spool, it should not be allowed to pile up at any one point.

**Constructing the Cores.** Uncoil enough 16- or 18-gauge soft iron wire to make the engine core, grip one end in a vise, grasp the opposite end with a pair of pliers, and pull until you can feel the wire stretch somewhat. This will straighten the wire. Cut the wire into  $4\frac{3}{4}$ " lengths and make forms to hold the bundle in cylindrical form from pieces of thin-wall metal or plastic tubing. Holes ( $\frac{9}{16}$ " ) drilled in small pieces of wood or cardboard can also serve the purpose. Since the forms must be cut away after the core is glued, keep their outside dimensions down to a minimum.

Bundle the  $4\frac{3}{4}$ " wires together and insert them in the forms. Press the end of a screw eye into the center of one end of the core, and cut off the ends of the wires forced out of the core at the opposite end. Withdraw the screw eye—it will be fastened permanently later. Apply epoxy glue to the areas of the core not covered by the forms holding the core wires and allow the glue to set. The type of epoxy glue that will set with artificial heat is preferred for this, since

Straighten the iron wire for the cores by stretching it as explained in text. Then cut and bundle the wires into cylindrical form as shown in Fig. 2.

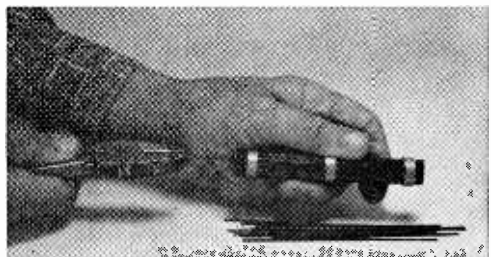

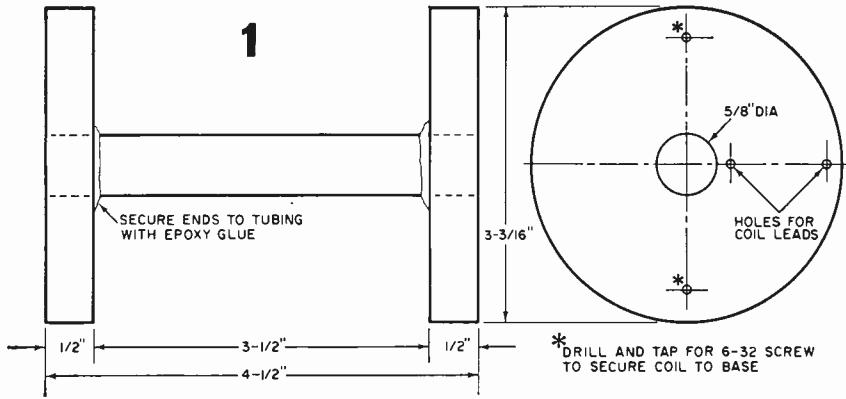

Coil form may be made of fiber, plywood or Micarta. End plates must be strong and firmly glued to center.

Both cores are made of #16- or #18-gauge soft iron wire. Straighten the wire as shown in the photograph on the bottom of the facing page.

This arm couples the flywheel to the core, which acts as the piston. Prototype was cut from brass stock.

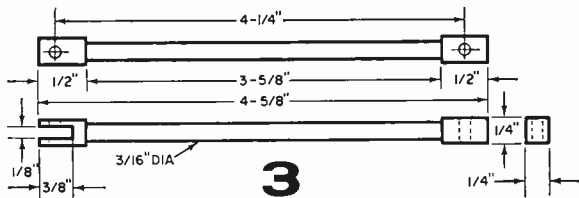
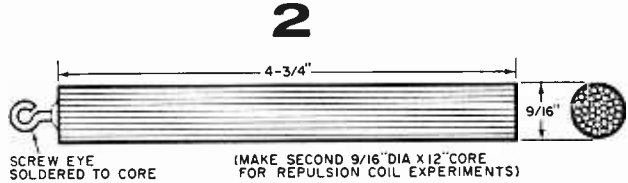

Several small parts must be fabricated to connect the arm to the flywheel. At right, below, are two possible ways of constructing the engine crankshaft.

The flywheel weighs about 15 ounces. The author used aluminum, but plastic or brass would serve as well. War surplus stores or machine shops may have such flywheels for sale.

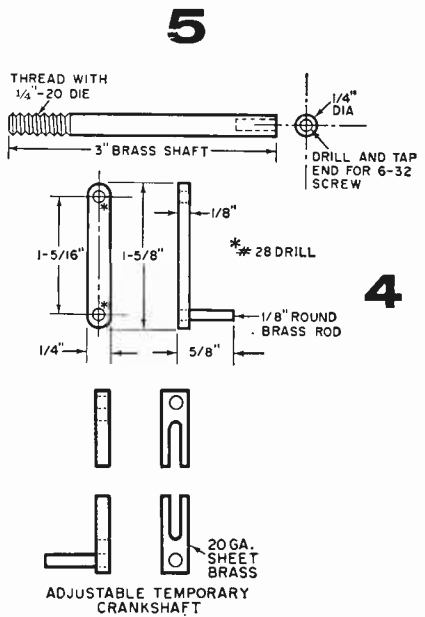
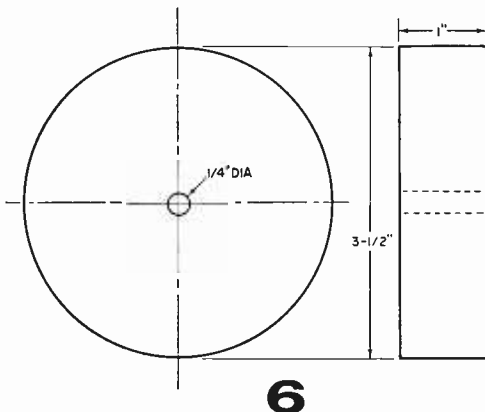

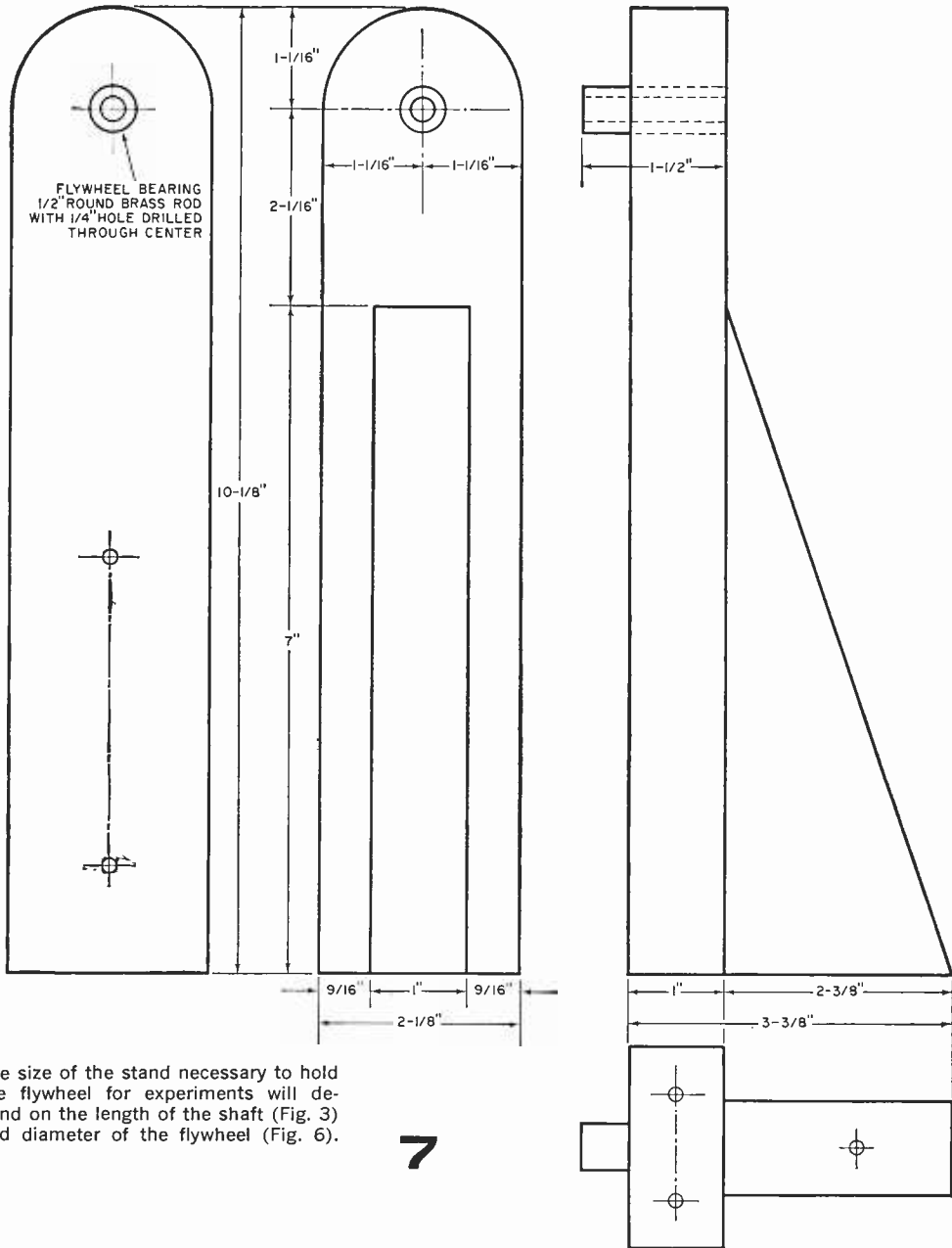

The size of the stand necessary to hold the flywheel for experiments will depend on the length of the shaft (Fig. 3) and diameter of the flywheel (Fig. 6).

## BILL OF MATERIALS

C1—1- $\mu$ f., 600-volt non-electrolytic capacitor  
 C2—2- $\mu$ f., 600-volt non-electrolytic capacitor  
 C3—10- $\mu$ f., 600-volt non-electrolytic capacitor  
 J1, J2, J3, J4—Insulated pin jack  
 L1—See text  
 R1—10,000-ohm, 10-watt resistor  
 S1—D.p.d.t. (center-off) 10-amp toggle switch (motor start type)  
 1—2 1/2-lb. spool of 24-gauge magnet wire, cotton- or enamel-covered  
 1—1-lb. spool, 16- or 18-gauge soft iron wire

2—3 1/16"-diameter, 3/8"-thick discs of fiber, Micarta, or wood  
 1—3/8"-i.d., 4 1/4"-long piece of fiber or Micarta tubing, or wood dowel  
 1—3 1/2"-diameter, 1"-thick flywheel; aluminum, brass or plastic—see text  
 Misc.—Brass rods for crankshaft and connecting rod, wood for bracket and base of engine, brass bearing, wood screws, machine screws and nuts, wire, solder, a.c. line cord, epoxy glue, etc.

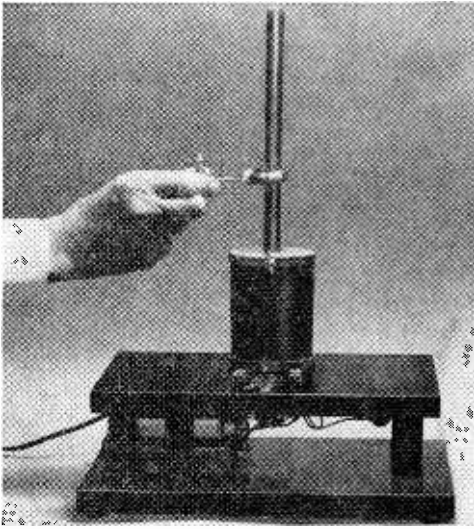

A small coil connected to a flashlight bulb illustrates transformer action of mutual inductance.

Permissible changes in certain component values are discussed in text. However, do not eliminate discharge function of the d.p.d.t. toggle switch.

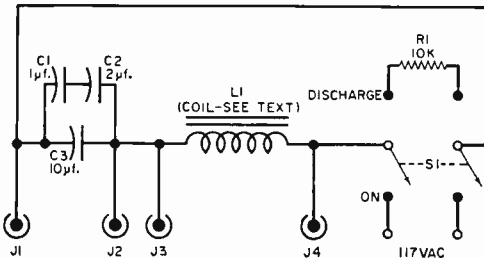

drying time is shortened and because surplus glue may be more easily pared off. After the glue has set, remove the forms and apply epoxy to the uncovered core areas. When this second application is dry, remove any rough spots on the core with a coarse file. Solder a screw eye in the hole that was made in the end of the core. The finished core should look like Fig. 2, on page 90.

For the repulsion coil experiments, make another core following exactly the same procedure outlined, but using 12" iron wires and omitting the screw eye.

**Parts for the Engine.** The connecting rod (Fig. 3, page 90) is made with  $\frac{3}{16}$ " brass tubing soldered into pieces of  $\frac{1}{4}$ "-square brass, the ends of which have been drilled and shaped as shown. This

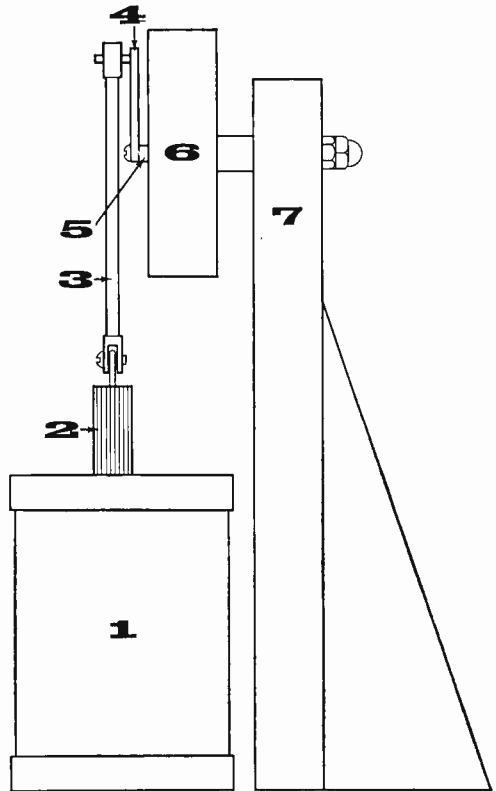

This is how the various pieces for the resonant engine shown in detail on page 90 are assembled.

construction was used to "dress up" the prototype, and need not be duplicated exactly. A rod made from a single solid piece of brass will work as well.

The engine crankshaft is shown in two forms in Fig. 4. If you want to experiment with different values of capacitors, or longer or shorter piston travel with a corresponding change in speed, build the slotted version so you can adjust its length. The two parts are held together with a small machine screw and nut. Since this is made of lighter material, it is not recommended for permanent use. If all the values and measurements given for the engine are followed, make a solid crankshaft exactly like that shown.

The engine flywheel is made of brass or aluminum, and is 1" thick and  $3\frac{1}{2}$ " in diameter. It is supported by a  $\frac{1}{4}$ " brass shaft 3" long (see Figs. 5 and 6, page

*(Continued on page 141)*



# BIG TC

*A quarter of a million volts? All it takes is a transformer, a capacitor, a spark gap, and Tesla's famous coil*

By CHARLES CARINGELLA, W6NJV

**T**ESLA COILS have fascinated experimenters ever since the early 1900's when Nikola Tesla first experimented with giant coils that produced lightning-like discharges which would span his laboratory—the work of millions of volts of electricity. The Tesla coil described here is smaller than some of Tesla's designs, but it's capable of putting out almost a quarter of a million volts! Brilliant corona discharges as long as a foot or more provide a spectacular display of its intense electrical field, and neon and fluorescent lamps can be excited as far as five feet away.

Intended both as a dynamic demonstrator of electrical principles and as a crowd-attracting science fair project, "Big TC" can be put together for about \$30. However, if a used transformer from a neon sign shop can be secured reasonably, the cost will be even less

**WARNING:** The voltages used in this project are highly dangerous. Inexperienced persons should seek aid from an instructor or other expert before building it.

COVER STORY

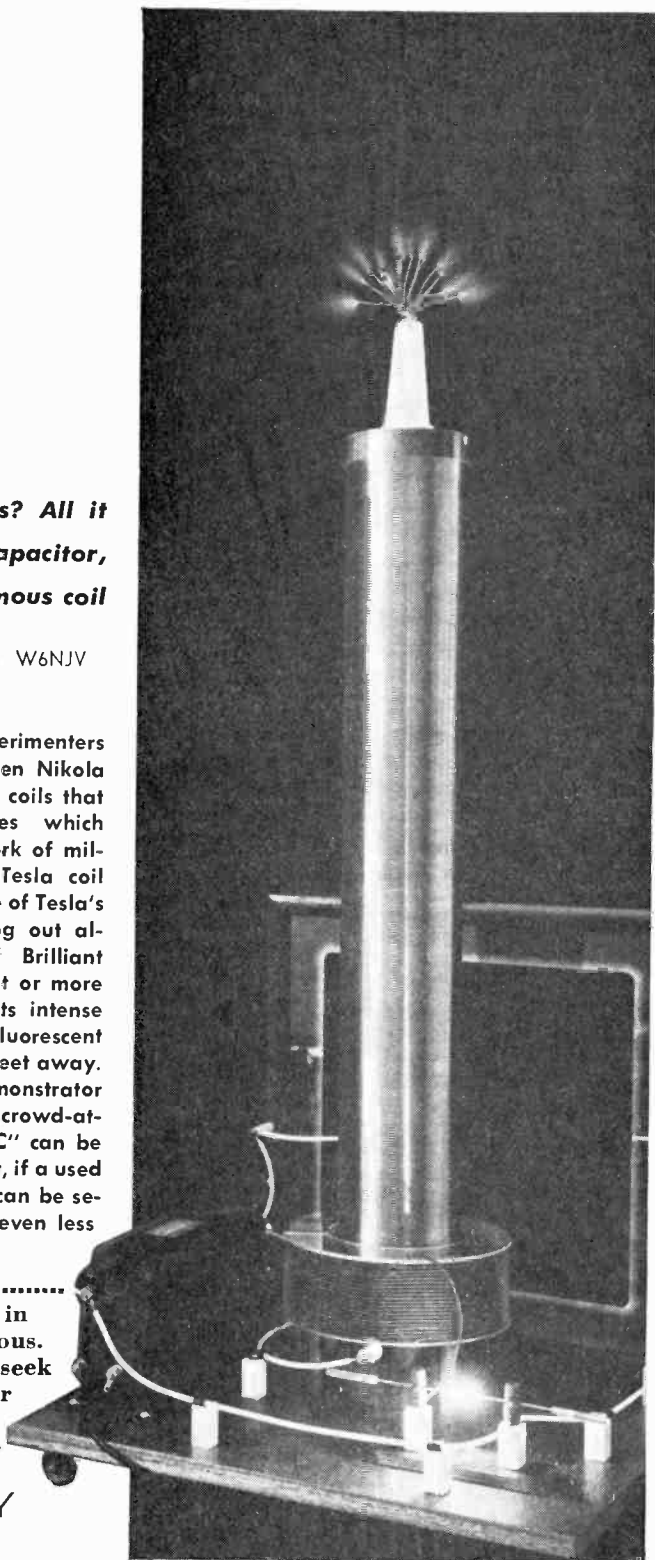



# BIG TC

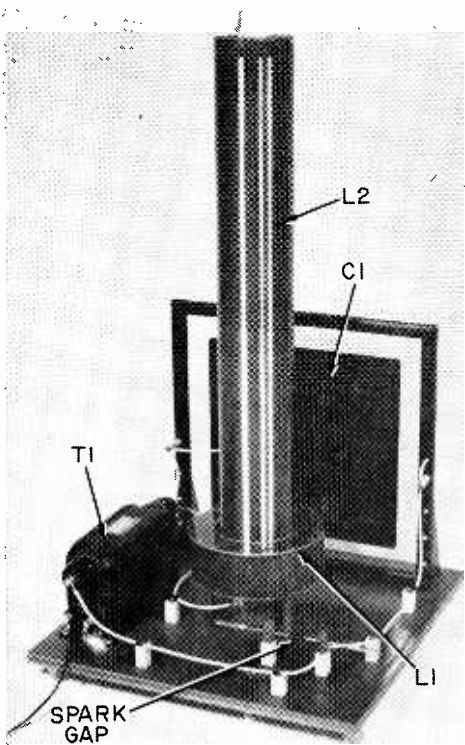

Mount L1-L2 in center of base, T1 and C1 at edges. A bigger base and greater component spacing will permit greater voltage output with less arcing.

As shown in the schematic diagram above, *T1* steps the household line voltage up to 12,000 volts. The transformer is the type commonly used to operate neon signs. A high-voltage glass-plate capacitor, *C1*, is connected directly across the high-voltage secondary winding of *T1*. The capacitor serves as an energy storage device, charging up to *T1*'s secondary voltage and then discharging in response to the 60-cycle a.c. voltage.

Discharging of *C1* is through the spark gap into coil *L1*. Each time the spark gap "fires," a high current flows through *L1*. The larger capacitor *C1* is made, the larger will be the current through *L1*. Discharges across the spark gap produce extremely jagged pulses of power which are very rich in r.f. harmonics. The energy—due to the values

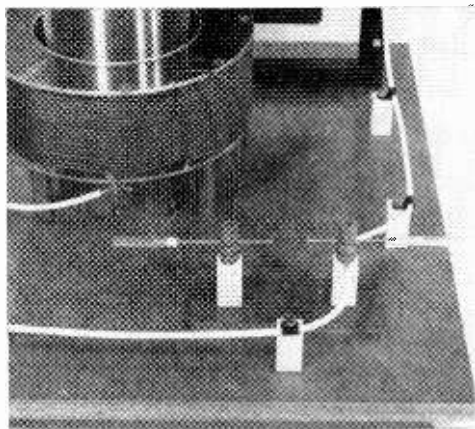

Spark gap generates r.f. energy to excite coil. It consists of two copper rods mounted on standoffs.

The secondary of a neon sign transformer is usually grounded internally to the metal case. Connect bottom of Tesla coil secondary to case and to a good external ground, such as a water pipe. This precaution will keep danger of a short circuit in transformer at a bare minimum.

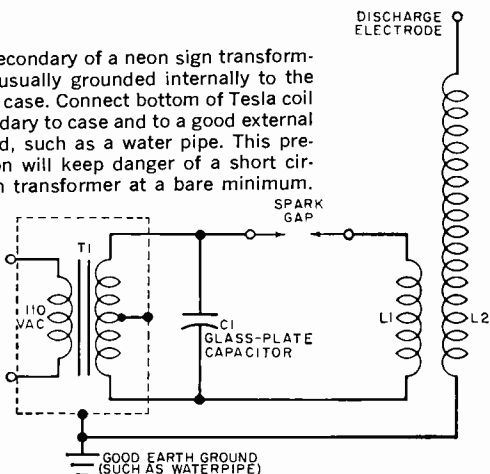

of the components used—is greatest in roughly the 100-kc. region.

Windings *L1* and *L2* form an air-core step-up transformer, with *L1* the primary and *L2* the high-voltage secondary. The voltage at *L2* will be 75,000 to 250,000 volts depending on the size of *C1*.

**Design and Layout.** The prototype of "Big TC" was built on a plywood base measuring  $\frac{3}{4}$ " x 22" x 22", although a larger base would be desirable for high-voltage units to prevent arcing between *L2* and *T1* and *C1*. Mount *L2* in the center of the base and *T1* and *C1* as close to the edges as possible; if you plan to operate the unit at voltages exceeding 100,000 volts, make the base 3' x 3' for even greater separation between components.

Power transformer *T1* is the only

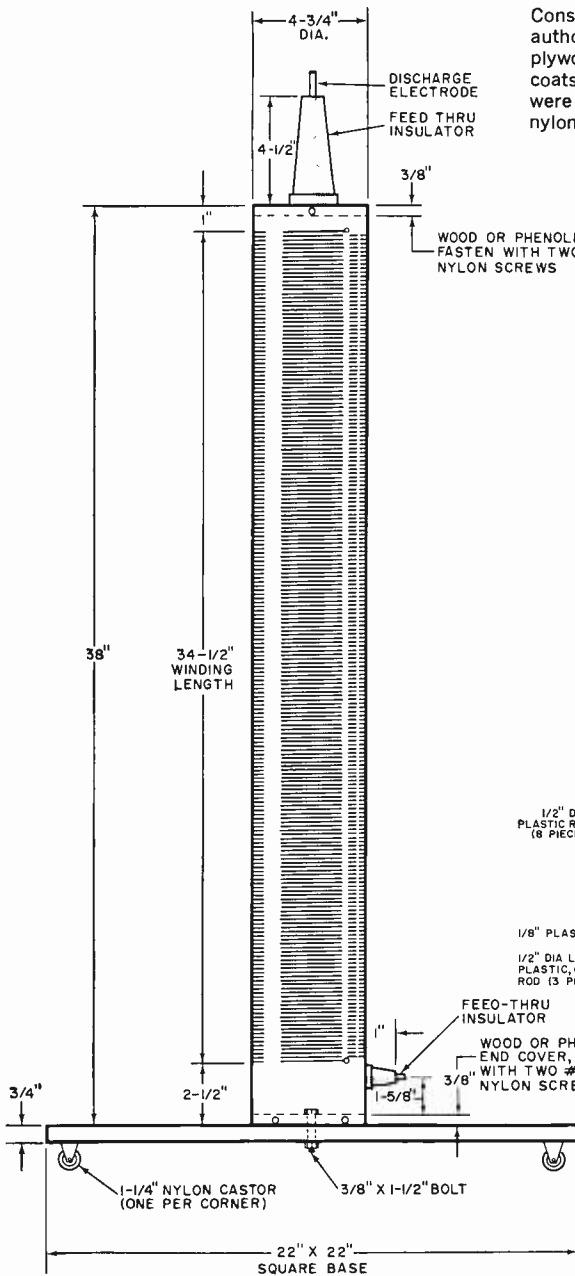

Constructed for classroom demonstration, the author's unit was mounted on mahogany veneer plywood which was sanded and covered with five coats of plastic varnish. Other finishing touches were wood tape veneer around the edges, and nylon casters to make the unit easy to move.

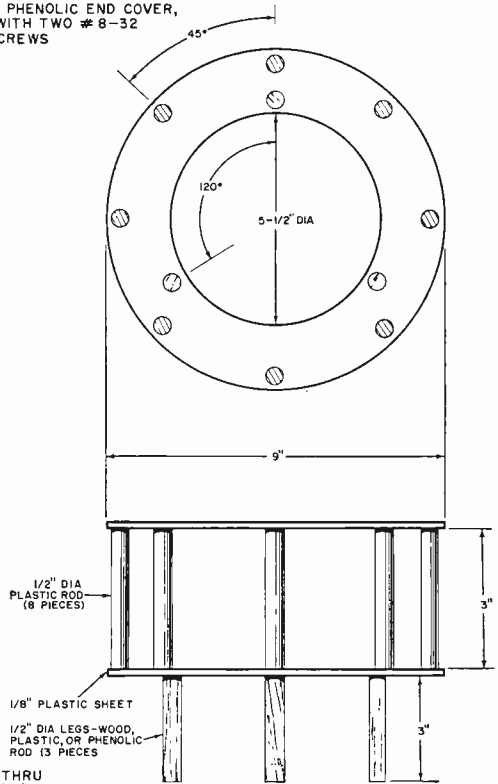

Form for L1 with center cut out to take base of L2 is shown above. Polystyrene was used, but wood or cardboard can be substituted. The critical dimension is the outside diameter; less than 9" will result in arcing between coils L1 and L2.

The various dimensions of the prototype coil are indicated in the drawing; none is particularly critical. Note that space has been left at each end of coil, and that stand-off insulators are used to bring out the ends. Nylon screws or glue must be used to fasten top end cover to avoid arcing. After winding coil, cover with many coats of acrylic plastic spray. Spray form first if cardboard is used. Details on spark gap are shown at right.

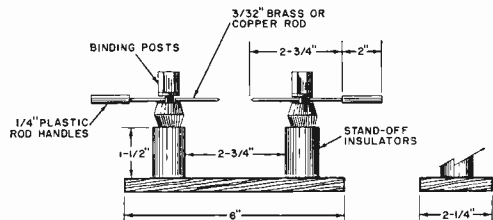

# BIG TC

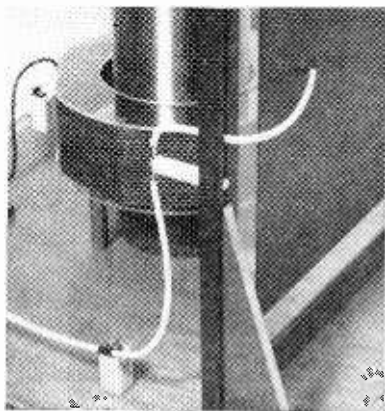

Leads are soldered directly to capacitor plates. Note use of stand-off insulators.

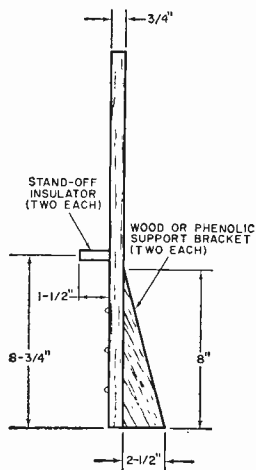
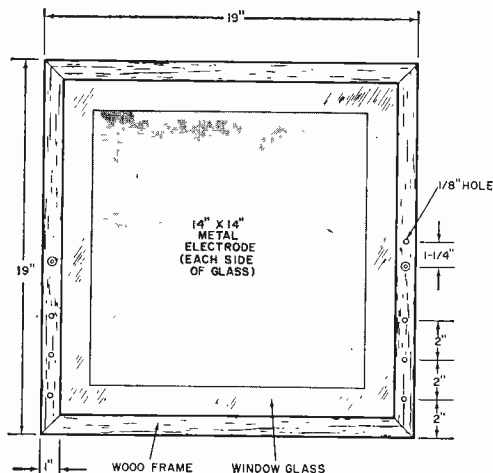

Glue metal plates to glass, leaving a generous margin of glass on all sides (see text). Epoxy glue, contact cement, or any other glue which will form a tight bond can be used. The wood frame protects the glass and makes mounting it possible.

high-cost component. A neon-sign unit rated at 12,000 volts a.c. at 30 ma., it sells for about \$40 new, but used transformers are constantly being salvaged by sign shops, and can be picked up for \$10 to \$20. It is also possible to find neon signs in junk yards, in which case you can probably buy the transformer for practically nothing. The author used a GE unit, No. 51G473, known technically as a "luminous tube transformer." Measuring  $9\frac{1}{2}$ " x 6" x 4", it has 2" feedthrough insulators at either end connecting to the high-voltage winding.

Primary coil *L1* and all connecting leads must be made with high-voltage wire, preferably supported away from the base on 1" ceramic standoff insulators. Test prod wire such as Belden Type 8899 is ideal—it has flexible rubber insulation with a puncture voltage rating of 20,000 volts.

**Winding the Coil.** For the big coil (*L2*) a phenolic coil form\* measuring  $4\frac{3}{4}$ " in outside diameter and 38" in length was used. Alternately, cardboard, wood or other insulating materials can be substituted. You can improve these latter types of coil forms by spraying on at least six coats of acrylic plastic spray before winding the wire on them.

The winding itself is done with No. 26 Formvar-insulated wire—two 1-lb. spools (splice them together and keep the solder joint as small as possible) will give you a 2000-turn, tightly spaced coil covering  $34\frac{1}{2}$ " of the coil form. There should be extra space between the ends of the winding and the ends of the form—see the drawing on page 95.

The lower end of the coil is terminated at a 1" feedthrough insulator installed in the side of the form, the top end of the coil at a  $4\frac{1}{2}$ " feedthrough mounted to the top end of the form. Make the end covers of wood or phenolic discs cut to the inside diameter of the coil form, and mount them in place with

\*Tubing can be found in metropolitan areas at surplus houses and establishments which sell plastics (sheets, rods, etc.). Clear acrylic tubing (48" long,  $4\frac{1}{2}$ " O.D.) can be ordered from Industrial Plastics Supply Co., 324 Canal St., New York, N. Y. 10013, for \$13.85 including shipping charges and postage; address your order to the attention of Mr. Charles Roth.

This Mark II version of "Big TC" used a second outboard capacitor—increasing the capacity across the primary by 0.0014 uf. Estimated output of the Mark II model was about 130,000 volts. See page 96.

nylon screws (metal screws at the top end would produce corona discharges which could burn the coil form). Alternatively, the top coil cover can be cemented in place with epoxy cement if a sturdy coil form is used. The coil is attached to the base with a  $\frac{3}{8}$ " bolt.

Winding the coil is not nearly as difficult as it appears—the author completed the task in about two hours. Spray the entire winding with acrylic plastic for added insulation, moisture protection, and to keep the windings in place. You can't overdo this step—the author used the contents of an entire aerosol spray can on the prototype, applying one thin layer at a time and letting it dry before adding another.

**Building the Primary.** As shown on page 93, the form for  $L1$  was made with polystyrene rods and sheeting. While the plastic has excellent insulating qualities and looks attractive, wood or even cardboard can be substituted. If plastic is used, it can be strongly "welded" together with acetone. Regardless of the material used, the form should have an outside diameter of at least 9" to avoid arc-over between  $L1$  and  $L2$ . The coil itself ( $L1$ ) consists of 20 turns of heavy test prod wire.

**Spark Gap.** The spark gap is simply two ordinary binding posts mounted on stand-off insulators. In turn, these are mounted on a phenolic base measuring  $\frac{3}{8}$ " x  $2\frac{1}{4}$ " x 6". The electrodes are brass and copper rods with a gap on the order of 1" between them. This distance will vary slightly, depending on the size of capacitor  $C1$ .

**Fabricating the Capacitor.** The capacitor consists of two 14" x 14" sheets of

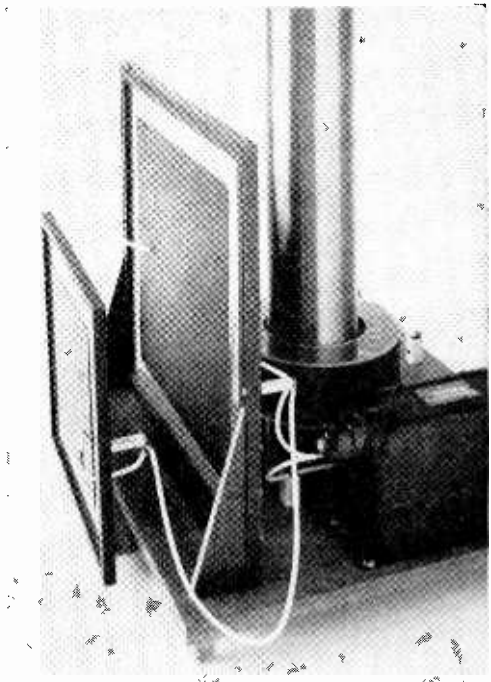

tin cemented to a  $18\frac{1}{2}$ "-square piece of window glass. Although aluminum foil can be used for the capacitor plates, tin was obtained from a sheet metal shop for this purpose so that connecting leads could be soldered directly to it. If you use aluminum foil, a fairly good connection can be had by making leads of  $\frac{1}{2}$ "-wide aluminum foil strips and taping them down to the electrodes.

Glass is an excellent dielectric material for this application since it has an extremely high puncture voltage and a high dielectric constant. As you will note in the drawing on page 94, a border of glass is left around the capacitor plates—this should be at least  $1\frac{1}{2}$ " wide. The calculated capacity of  $C1$  is approximately 0.0027  $\mu$ f.

**Testing and Operation.** Caution! Adjustments to the Tesla coil, and specifically to the spark gap, should be made *only* when the unit is *off*. Although the output voltage of the Tesla coil may be on the order of 150,000 volts, the current capacity is only hundreds of microamps. This current can inflict a nasty shock and r.f. burns, however.

Use **EXTREME CAUTION** around the neon sign transformer. It delivers 12,000 volts at 30 ma., and this voltage could be lethal under certain conditions.

Again, be sure the plug is out when you make adjustments.

To adjust the spark gap, first open it to about  $1\frac{1}{2}$ " ; it will not fire at this point. Gradually move the electrodes together—unplugging the unit each time you adjust the gap—until the point is reached where the gap "fires."

The author's original version of "Big TC" produced an output voltage of about 100,000 volts with the single plate glass capacitor described above. To increase the output of "Big TC," it is only necessary to increase the capacity across the primary by adding one or more plate glass capacitors in parallel with *C1*. With two capacitors (both the same size as detailed on page 94), the author's prototype produced over 150,000 volts output; and with three capacitors in parallel, the output exceeded 200,000 volts. However, at such high voltage there was a tendency for insulation breakdown between coil *L2* and capacitor *C1*. This breakdown could have been overcome by making the mounting base larger and increasing the spacing between components.

The author's Mark II version of "Big TC" compromised by adding a second capacitor with half the plate area of *C1*. Except for size, this new capacitor was fabricated in exactly the same way and had a measured capacitance of 0.0014  $\mu$ f. The new capacitor was attached to the base board with a 6" x 9" piece of  $\frac{3}{8}$ "-thick phenolic board. Four retaining screws held the board to the underside of the base board and four more screws affixed the phenolic to the wooden frame of the outboard capacitor. With this second capacitor (see cover photograph), the voltage output was estimated to be in the neighborhood of 130,000 volts.

The output of your Tesla coil can be estimated by drawing an arc to a metallic object attached to a long wooden handle. Slowly increase the distance between the object and the discharge terminal until the arcing stops: a 6" arc represents 100,000 volts, a 14" arc about 200,000 volts, and a 21" arc some 300,000 volts. More amazing than figures, however, are the brilliant, spectacular phenomena exhibited by high-voltage, high-frequency electricity. —50—

# TELEX

## FOR QUALITY

The quality of Telex headsets has become well known to hams over the last twenty-five years. Here are three Telex headsets that deliver the kind of top grade performance that hams expect from Telex—

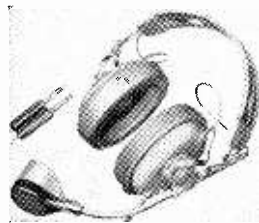

**MAGNA-TWIN**

For absolute maximum intelligibility under difficult QRM conditions... Super-comfort foam cushions... Rugged, moisture-proof magnetic drivers give broad response, excellent sensitivity... Sturdy construction of high impact plastic.



**TELESET**

Lightweight, economy version of the famous Magna-Twin... High performance, shock-proof Magna-Twin drivers... Designed especially for ham requirements.

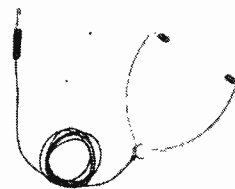

**MONOSET**

Feather-light at 1.2 oz... Eliminates headset fatigue... Sound from replaceable driver is fed directly into your ears through adjustable tone arms... Telex quality construction assures reliability.

Write for descriptive literature today.



**TELEX/Acoustic Products**  
COMMUNICATIONS ACCESSORIES

Dept. EH-I 3054 Excelsior Blvd. • Minneapolis 16, Minn.

CIRCLE NO. 30 ON READER SERVICE CARD



# Li'l TC

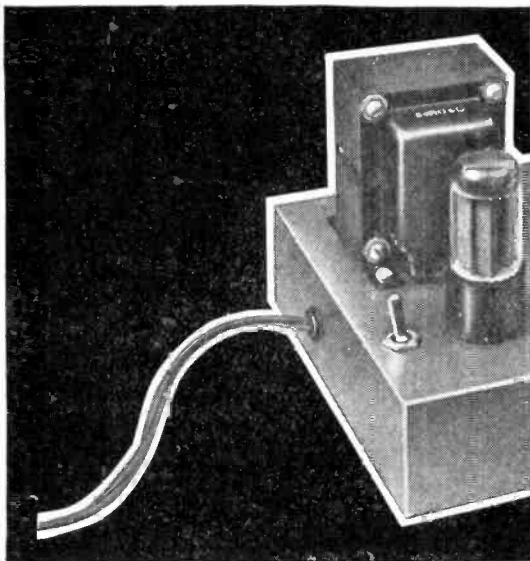

If you have read the preceding article on "Big TC," you will have learned that a Tesla coil is simply a radio-frequency step-up transformer carried to extreme limits. While a coil that can generate 150,000-200,000 volts is exciting and very dramatic, many of the same visual effects can be demonstrated on a smaller scale with "Li'l TC." In fact, "Li'l TC" is much safer, easier to build, and less expensive.

The only item many experimenters will have to buy in order to build "Li'l TC" is the r.f. coil. This coil is manufactured by the J. W. Miller Co. for use in generating the high voltages required in large-screen TV receivers. It is an item that is not stocked by many parts stores, although most of them can obtain it for you within 48 hours. If you have trouble finding the coil, it can be ordered from Allied Radio Corp., 100 N. Western Ave., Chicago 80, Ill., as their stock number 61G102 at a price of \$8.82 plus postage. An experienced project builder may not find it necessary to buy one of these coils, but may be able to

**A potent "little brother" to "Big TC," this Tesla coil version is inexpensive, easy to build, and it can put out 30,000 volts!**

**By EDWIN N. KAUFMAN**

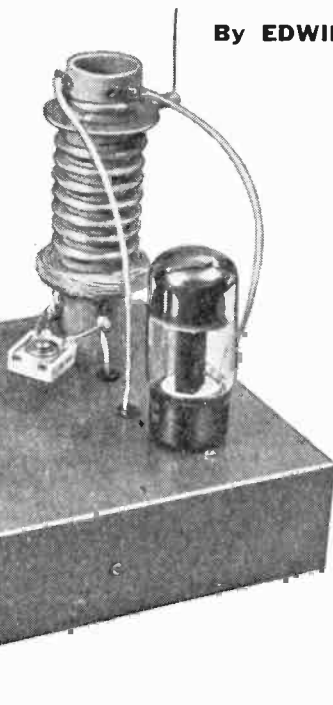

# Li'l TC

Tuning capacitor C3 is attached to the h.v. coil with two bus-bar leads so that it will be suspended in mid-air away from the coil and metal chassis. Use an insulated alignment tool to rotate the setscrew adjustment.

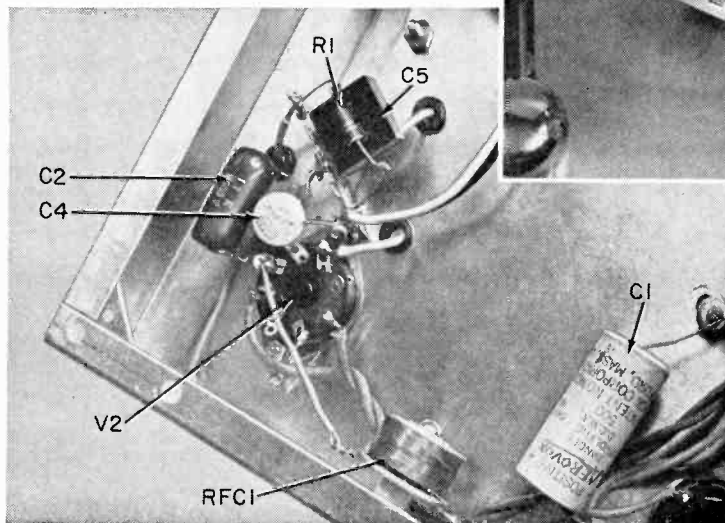
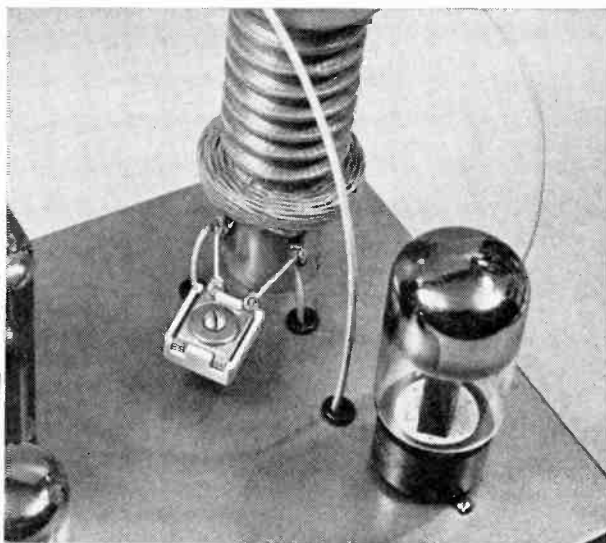

Most of the parts are grouped around the base of tube V2. Leads to the h.v. coil pass through grommets holes to the terminal connections on the Miller coil form.

construct "Li'l TC" using a high-voltage transformer from a large-screen old-style TV receiver.

**Construction.** The mechanical layout is not critical, and the design shown in the photographs need not be followed exactly. It is convenient to place the r.f. coil off in one corner of the chassis and to drop the connecting leads to V2 through grommets holes in the chassis deck. The high-voltage output lead of the coil is shortened and a sewing needle soldered to the end to show "point discharge" effects.

The power supply is of conventional design and the B-plus applied to the plate of V2 can range from 250 to 500 volts. However, 250 - 350 volts is more than ample for an output of between 12,000 and 15,000 volts. The output will also vary according to the type of tube used at V2. When you open the coil box, you will see that a 6Y6 is recommended

by the manufacturer. However, noticeably improved effects were obtained by the author by substituting a 6L6. A 6V6 or another equivalent power pentode would do in a pinch.

Capacitor C3 is used to tune the primary of the h.v. coil. For convenience, two bus-bar leads about 1" in length were soldered to the capacitor and used to support it in mid-air. The remaining components are scattered around below the chassis deck.

**Firing Up Li'l TC.** When used in a TV receiver, the high voltage generated by this coil/oscillator arrangement is rectified and filtered. It is then considerably more dangerous than the unfiltered r.f. generated by Li'l TC. Nevertheless, Li'l TC should be treated with respect, for the voltage can puncture the skin of a finger, although high-frequency voltages usually tend to flow relatively harmlessly along the skin's surface.

The numbered terminals shown in this wiring diagram pertain to the Miller 4526 coil. A separate instruction sheet accompanying the coil identifies the positions.

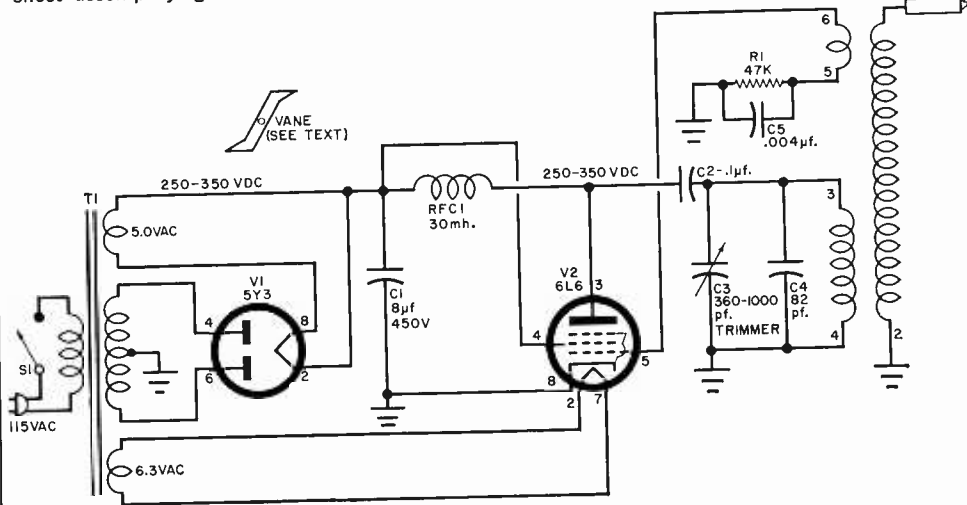

#### PARTS LIST

C1—8.0- $\mu$ f., 450-volt electrolytic capacitor  
 C2—0.1- $\mu$ f., 600-volt molded capacitor  
 C3—360-1000 pf. trimmer capacitor  
 C4—82-pf., 1.6-kv. ceramic capacitor—see text  
 C5—0.004- $\mu$ f., 600-volt mica capacitor  
 R1—47,000-ohm,  $\frac{1}{2}$ -watt resistor  
 RFC1—30-mh., 100-ma. r.f. choke (J. W. Miller 692 or equivalent)  
 S1—S.p.s.t. toggle switch  
 T1—Power transformer: primary, 117 volts a.c.;

secondaries, 500 volts, CT, 5 volts at 2 amperes, and 6.3 volts at 2.5 amperes (Thordarson 24R09U or equivalent)  
 V1—5Y3 tube  
 V2—6L6 tube—see text  
 1—High-voltage coil (J. W. Miller 4526—see text)  
 1—Metal chassis (Premier ACH-404 or equivalent)  
 Misc.—Tube sockets, wire, solder, etc.

After double-checking your wiring, turn on the a.c. power and permit the two tubes to warm up. Take an insulated screwdriver—something like a long alignment tool—and adjust C3 for a brush discharge from the needle point. If you do not have enough range in C3 to tune through the maximum discharge, change the value of C4—add more capacitance at C4 if the plates of C3 are tightly meshed; use less if C3's are too loose. You can set C3 for maximum discharge by listening to the sound of the brush effect—tune for a clean high-pitched hiss and not a sputtering sound.

The brush discharge from Li'l TC will be about 1" in height and can be seen best in a dimly lighted room. Actually, a brush corona will appear at any sharp edge on the output lead, so be careful to round out the soldered connections between the eye of the needle and the shortened h.v. lead.

**Ionic Propulsion Vane.** Probably the most impressive demonstration of a Tesla coil is the ionic propulsion vane. You can make one for Li'l TC by cutting out the general pattern shown in the diagram above.

Make the over-all length of the vane about 1" to 1 $\frac{1}{2}$ ". Cut the vane from aluminum foil and puncture the center so that the vane is balanced. Use one of your wife's extra beads as a bearing by slipping it on the upright needle. Then drop the vane over the needle so that it rests on the bead and can rotate freely. Put a piece of cork or rubber on the tip of the needle to stop the vane from picking up so much speed that it spins right off the needle.

The photograph on the first page of this article is a two-second time exposure (slightly enlarged) showing what the brush corona discharge and rotating vane should look like.





How to go about selecting the best hi-fi equipment in your price range (avoiding all the nerve-racking guesswork, to say nothing of the costly disappointments)...in a nutshell.

The "meat" in this nutshell is guaranteed to whet the appetite of every audiophile and music lover who plans to buy hi-fi equipment during the next twelve months.

In over 172 fact-and-photo-filled pages, the new 1966 STEREO/HI-FI DIRECTORY gives you all the vital statistics on amplifiers, changers and turntables, cartridges, tonearms and accessories, receivers, tuners, tape machines, speakers and cabinets—on every hi-fi component being manufactured today!

With this authoritative guidebook, you can compare similar items, feature-for-feature, dollar-for-dollar, before you buy! You'll avoid making even one costly mistake by making sure, in advance, that you get the best value for your money, on anything and everything you buy!



**First Time Ever Offered!**  
**A DELUXE, GOLD-EMBOSSSED**  
**LEATHERFLEX-BOUND EDITION**  
 ... just \$3.00 postpaid

This deluxe edition is a permanent, handsomely-bound collector's item that belongs in your hi-fi library! Check appropriate box on coupon.

The 1966 STEREO/HI-FI DIRECTORY will help you select the finest equipment in your price range, so that you can derive greater pleasure than ever from your records and tapes. Now, (to ask a redundant question) where else can you get this kind of "satisfaction insurance" for a mere \$1.25?

**—FILL IN, DETACH & MAIL COUPON TODAY!—**

ZIFF-DAVIS SERVICE DIV., Dept. SD  
 589 Broadway, New York, N.Y. 10012

Yes! Send me the new, 1966 STEREO/HI-FI DIRECTORY checked below:

\$1.25 enclosed, plus 15¢ for shipping and handling. Send me the regular edition. (\$1.50 for orders outside U.S.A.)

\$3.00 enclosed. Send me the Deluxe Leatherflex-Bound edition, postpaid (\$3.75 for orders outside U.S.A.) Allow three additional weeks for delivery.

name \_\_\_\_\_ please print \_\_\_\_\_

address \_\_\_\_\_ EEH-65

city \_\_\_\_\_ state \_\_\_\_\_ zip code \_\_\_\_\_

**—PAYMENT MUST BE ENCLOSED WITH ORDER—**

# CHAPTER

## 5 COMMUNI- CATIONS SWL CB HAM

Projects included in this chapter of the *ELECTRONIC EXPERIMENTER'S HANDBOOK* are aimed at the 6-meter ham with a Technician Class license. In case you are not already aware of it, Technician Class hams can operate in the 50-mc. band and above. The license requires passing the regular theory examination but only a 5-wpm code sending and receiving ability. It is issued for a 5-year period—unlike the Novice license (1 year)—and can be renewed.

A companion unit to the 6-meter receiver (*ELECTRONIC EXPERIMENTER'S HANDBOOK*, 1964 Edition) is the 6-meter transmitter on page 111. If you want to improve receiver sensitivity, the small outboard r.f. preamplifier (page 121) may be your cup of tea. Also intended for the Technician (or General Class ham) is the solid-state converter (page 104). This converter has extraordinary sensitivity and can be broadbanded to cover 1.5 megacycles.

Two valuable projects round off this chapter: a speech filter with fully adjustable controls (page 107), and some excellent ideas on how to pep up AM receiver sensitivity (page 116).

104	TRANSISTORIZED 6-METER CONVERTER ....Roy C. Hejhall, K7QWR
107	AN ADJUSTABLE SPEECH FILTER .....Daniel Meyer
111	THE COMPANION 6-METER TRANSMITTER...Charles Green, W3IKH
116	SOUP UP THAT AM BROADCAST RECEIVER..F. J. Bauer, Jr., W6FPO
121	THE 6 METER 7 AND 2 PREAMP .....Joseph Tartas, W2YKT

# TRANSISTORIZED 6-METER CONVERTER

By ROY C. HEJHALL, K7QWR



*Build a  
sensitive converter  
using inexpensive  
mesa transistors*

**G**OOD PERFORMANCE can be obtained on six meters with a transistorized converter that uses inexpensive transistors and is easy to construct. The converter described in this article incorporates three Motorola 2N963 *pnp* mesa transistors which can be purchased for about the same price as a set of tubes for a vacuum-tube converter. The total parts cost (including the transistors and the 43-mc. crystal) is under \$20 if all new components are employed. Sensitivity of the unit is about 1 microvolt for a 10-db signal-to-noise ratio.

**The Circuit.** The converter consists of an r.f. amplifier, a mixer, and an oscillator. The r.f. amplifier stage is a neutralized common-emitter circuit. The mixer is also common-emitter, and base injection of the oscillator signal is used for simplicity. The crystal oscillator is a Colpitts type using a third-overtone crystal to generate the required 43-mc. oscillator signal directly. The intermediate frequency is 7 to 11 mc., which allows a 40-meter receiver with bandwidth to be employed for the low end of six meters. Input impedance of the converter is 50 ohms.

Power requirements are 9 volts d.c. at about 8 ma. Either a power supply or a 9-volt transistor radio battery can be used to power the converter. The power supply leads are filtered to reduce spurious responses.

**Construction.** The converter was constructed on a copper chassis, which was

cut and formed as shown in the photos, so that the completed converter could be enclosed in a gray LMB 5¼" x 3" x 2½" chassis box. Copper was selected for the chassis only for ease in soldering components directly to it; an aluminum chassis could have been used with equal success.

Each end of the chassis was slotted for BNC coaxial connectors; the connectors serve as input and output signal jacks and also clamp the chassis to the box. Care must be given to vertical placement of the chassis in the box, since the crystal above and coil forms below the chassis leave little clearance when the box is assembled. Two banana jacks were mounted in the box for power supply leads.

The usual precautions in VHF wiring, such as short leads and minimum chassis current paths, should be observed. The photograph of the bottom of the chassis can be used as a guide for layout. It is suggested that the general layout of the r.f. stage, including the shield between base and collector, be followed. Minor changes will be insignificant, but a radically different layout might affect neutralization.

There are no special precautions to be taken in the construction of the mixer and oscillator stages. The r.f. stage shield should also function to shield local oscillator signals from the r.f. stage input.

The coils are wound on ¼"-diameter coil forms. The oscillator coil is slug-tuned; the other coils have no slugs. Another version of the converter has been built by the author using no coil forms in the r.f. stage input and output

The 3-db bandwidth of this converter is approximately 1600 kc. Alignment should be set up on about 50.5 mc. to put the most sensitive part of the bandwidth in the low end of the 6-meter band. Good results can still be obtained up around 51.5 mc.

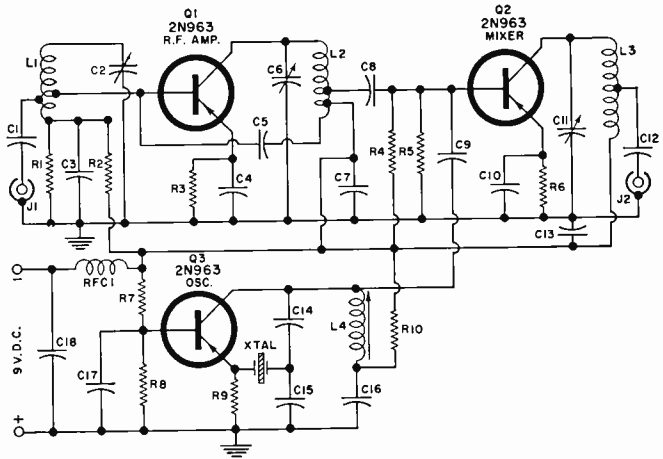

circuits, since the #20 wire used is rigid enough to support itself.

Building the converter on such a small chassis did cause some crowding of components, and a slightly larger chassis and box could be used, particularly if you want to power the converter with an internal battery.

**Alignment and Testing.** Before attempting alignment, a check for correct d.c. operating conditions should be made. About the simplest check is to measure total current drain; it should be about 8 ma.

The first step in the alignment procedure is to tune the r.f. input and output circuits and the mixer output circuit to approximate resonance, using a grid-dip meter. This can be done with the power to the converter off. Couple the grid-dip meter to *L1* and tune *C2* for resonance at 50 mc. In the same manner, couple to *L2* and tune *C6* for resonance at 50 mc. Then couple to *L3* and tune *C11* for resonance at 7 mc. In each

case, a definite dip should be obtained if the circuits are operating properly.

The next step is to adjust the oscillator coil (*L4*) slug. Set the slug about mid-range in the coil. Connect an r.f. signal generator to the converter input jack and connect the converter output to the antenna terminals of any receiver which will tune to 7 mc. Then connect a 9-volt d.c. power source to the converter. Apply a 50-mc. modulated signal to the converter and locate the signal with the receiver tuned to 7 mc. If the oscillator is detuned too far, it may not oscillate; so if the signal cannot be located at first, continue to search for it while slowly moving the oscillator slug. Once the signal is located, adjust the slug for maximum audio output in the receiver.

Now, with the 50-mc. signal still applied to the converter input, tune *C2*, *C6*, and *C11* for maximum signal output.

If the converter is constructed in a box, placing the cover on the box has a

A piece of copper is bent to form a sub-chassis and mounted as shown. Power for the converter goes through the tip jacks on the right-hand side of the box. If you have not already noticed, the converter is upside down in this illustration.

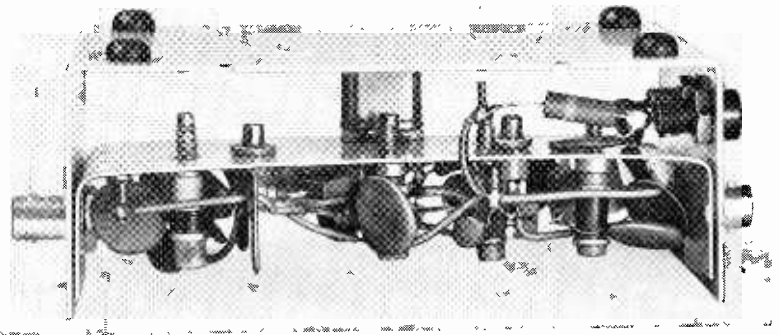

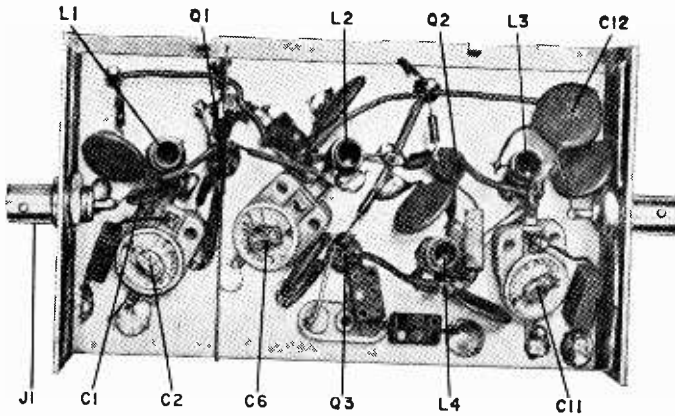

This under-chassis view of the converter shows the location of the major components. A shield extends across the socket of transistor Q1 to prevent coupling between L1 and L2. The crystal socket is just visible below Q3. Output jack J2 is unlabeled, but is located at the right of the chassis.

slight effect on alignment. Therefore, holes should be drilled in the box to allow the final peaking of C2, C6, and C11 to be done with the box assembled.

If no grid-dip meter is available, it is possible to skip the first alignment step by tuning C2, C6, and C11 all about mid-range, and using a strong signal from

the signal generator until the signal is located with the receiver. Once the signal has been located, the remainder of the alignment is carried out as described.

If no signal generator is available, tuning C2, C6, and C11 to approximate resonance with a grid-dip meter should be done first, as before. Then the converter input is connected to a 6-meter antenna and the remainder of the alignment procedure performed as previously described, except that on-the-air signals are used in place of the signal generator.

Alignment can be performed at any frequency in the 6-meter band where maximum sensitivity is desired. The 3-db bandwidth of the converter is 1.6 mc., and if the alignment is done at 50.5 mc., the converter will provide optimum performance from 50.0 to 51.5 mc.

Once proper alignment has been completed, it probably will never have to be done again, since transistor characteristics normally do not change with age and the life expectancy of the transistors is greater than that of the person constructing the converter. Also, the circuit operates at room temperature, so there is no heat present to harm the other components.

Some spurious responses may be encountered from strong TV or FM broadcast stations mixing with oscillator harmonics. The best cure for this is to place a trap for the offending station or a 6-meter low-pass filter ahead of the converter.

The author wishes to express his thanks to Frank Davis, K7VKH, for his valuable assistance throughout this project.

### PARTS LIST

- C1—0.003- $\mu$ f. disc ceramic capacitor
- C2, C6—5-80 pf. mica compression or ceramic trimmer capacitor
- C3, C7—0.1- $\mu$ f. disc ceramic capacitor
- C4—0.01- $\mu$ f. disc ceramic capacitor
- C5—18-pf. mica capacitor
- C8—0.001- $\mu$ f. disc ceramic capacitor
- C9—5-pf. mica capacitor
- C10—0.05- $\mu$ f. ceramic capacitor
- C11—25-280 pf. mica compression or ceramic trimmer capacitor
- C12, C13, C16, C17, C18—0.02- $\mu$ f. ceramic capacitor
- C14—12-pf. mica capacitor
- C15—82-pf. mica capacitor
- J1, J2—BNC coax connector
- L1—5 turns of #20 enamel-covered wire,  $\frac{1}{4}$ " diameter, close-wound; tapped 1 turn and 2 turns from cold end (0.15  $\mu$ h.)
- L2—8 turns of #20 enamel-covered wire,  $\frac{1}{4}$ " diameter, close-wound, tapped 2 turns and  $4\frac{1}{2}$  turns from cold end (0.19  $\mu$ h.)
- L3—26 turns of #28 enamel-covered wire,  $\frac{1}{4}$ " diameter, close-wound, center-tapped (2.3  $\mu$ h.)
- L4—10 turns of #26 enamel-covered wire,  $\frac{1}{4}$ " diameter, close-wound, slug-tuned (0.55 to 0.85  $\mu$ h.)
- Q1, Q2, Q3—2N963 transistor
- R1—5100 ohms
- R2—8200 ohms
- R3—1200 ohms
- R4—11,000 ohms
- R5—10,000 ohms
- R6—2000 ohms
- R7—12,000 ohms
- R8—2200 ohms
- R9—470 ohms
- R10—1000 ohms
- RFC1—18- $\mu$ h. r.f. choke
- Xtal—43-mc. third-overtone crystal

} all resistors  
 }  $\frac{1}{4}$  watt

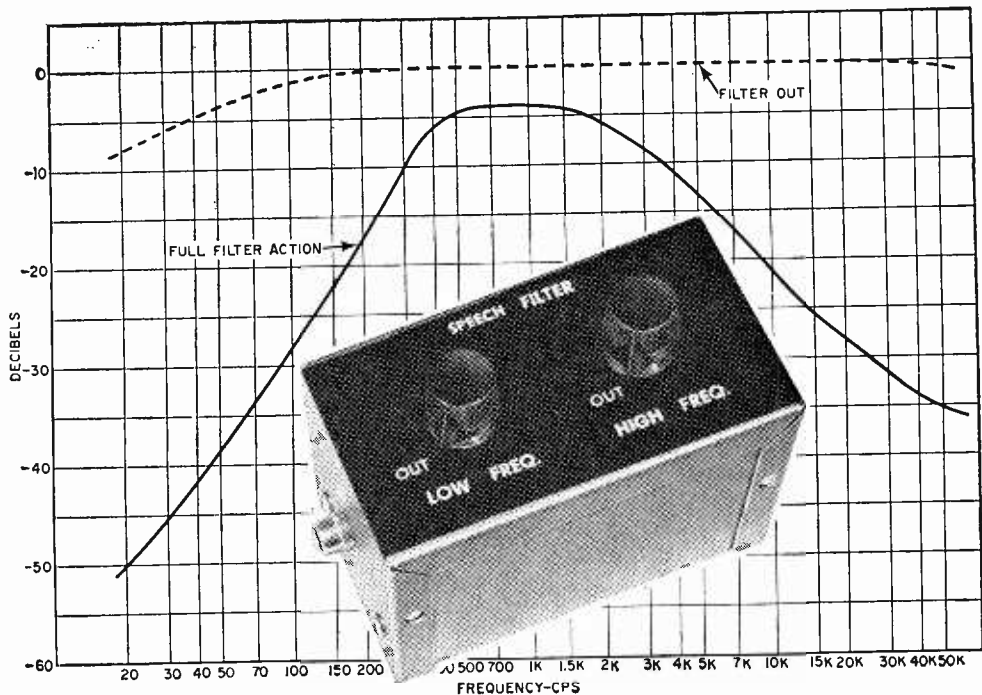

# An Adjustable Speech Filter

**Cut out noise and increase intelligibility with this all-purpose amateur, CB, hi-fi, and recording filter**

By DANIEL MEYER

**WOULD YOU LIKE** to have a speech filter to use with your CB receiver that could be adjusted to give the best reception for various signals and noise conditions? A filter that can also be used with your transmitter to get more modulation in the 300 to 3000 cycle range where it will do the most good? A versatile unit which can also be used with your hi-fi system to clear up the noise on old recordings or weak FM signals? If so, here is a simple three-transistor circuit that will do these jobs and more.

Two feedback-type filters are used to produce the high and low frequency attenuation. The circuit has zero unity gain and may therefore be used at any point in a system that has a signal level of one volt or less. In addition, the amount of high or low frequency filter-

ing may be adjusted and either filter may be switched out of the circuit to give a flat response.

**How It Works.** Transistor *Q1* is an emitter follower which gives the filter a high input impedance and also provides a low impedance driving source for transistor *Q2*. Capacitor *C2* and resistor *R3* form a feedback loop around transistor *Q1* that reduces the loading effect of the bias resistors *R1* and *R2* on the input of the filter.

Transistor *Q2*, with its associated resistors and capacitors, acts as a variable, *high-pass*, active filter. Potentiometer *R5* varies the cutoff frequency of the filter from approximately 100 to 400 cycles. In the "out" position of *R5*, switch *S1* closes and shorts out the filter.

Transistor *Q3*, with its associated components, is a variable, *low-pass*, ac-

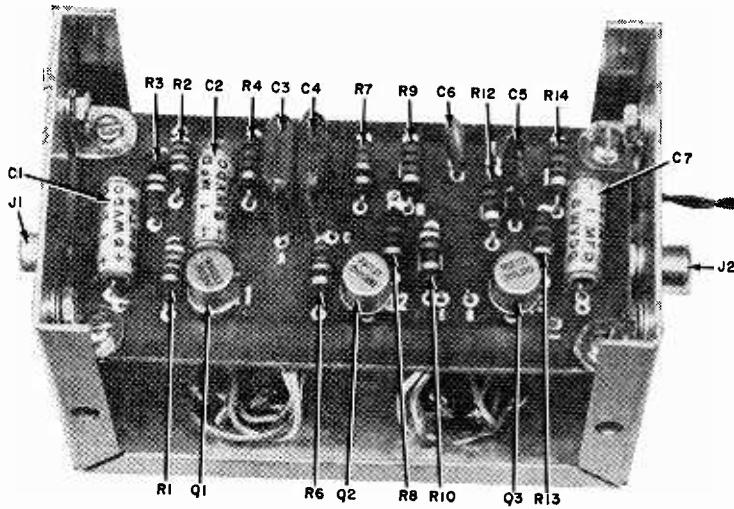

Refer to the schematic diagram on the facing page to locate the components in photo above.

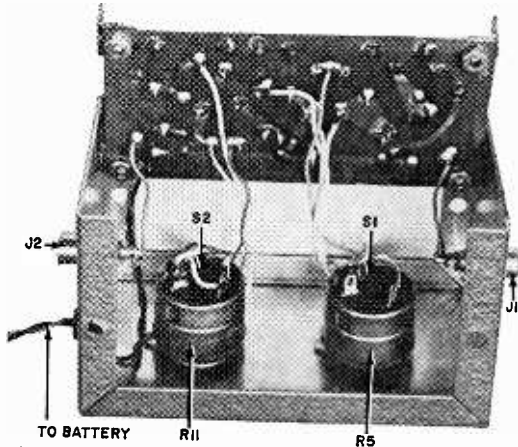

Potentiometers, switches and jacks are wired before the board is installed in cabinet.

tive filter. Potentiometer *R11* is used to vary the cutoff frequency of the filter from approximately 3000 to 6000 cycles. In the "out" position of *R11*, the normally closed pole of switch *S2* opens and breaks the signal connection to *R11*, while the normally open pole of the switch closes and shunts the signal around the filter.

The input impedance of the filter is about 50,000 ohms and the output impedance on the order of 1000 ohms. The circuit draws 6 ma. at 12 volts d.c. or 3 ma. at 6 volts d.c.

**Constructing the Filter.** The filter is built on a printed-circuit board to simplify construction and make for compactness. Install the parts on the board in the positions indicated, and solder to

the etched copper pattern on the reverse side of the board. Use rosin core solder throughout, and use an iron rated at less than 50 watts. Solder the connections as quickly as possible to avoid prolonged heating of the laminate.

Next, drill the holes for the connectors and the controls. Mark the hole positions with a punch, then use a  $\frac{1}{16}$ " drill to make pilot holes. Now drill out the connector holes to  $\frac{1}{4}$ " and the control mounting holes to  $\frac{3}{8}$ ". Place a block of wood under the metal during the drilling operation.

Cut the shafts of potentiometers *R5* and *R11* to a length of  $\frac{3}{8}$ " from the mounting bushing. Mount *R5*, *R11*, *J1* and *J2* on the case. Use lock washers between the controls and the case to

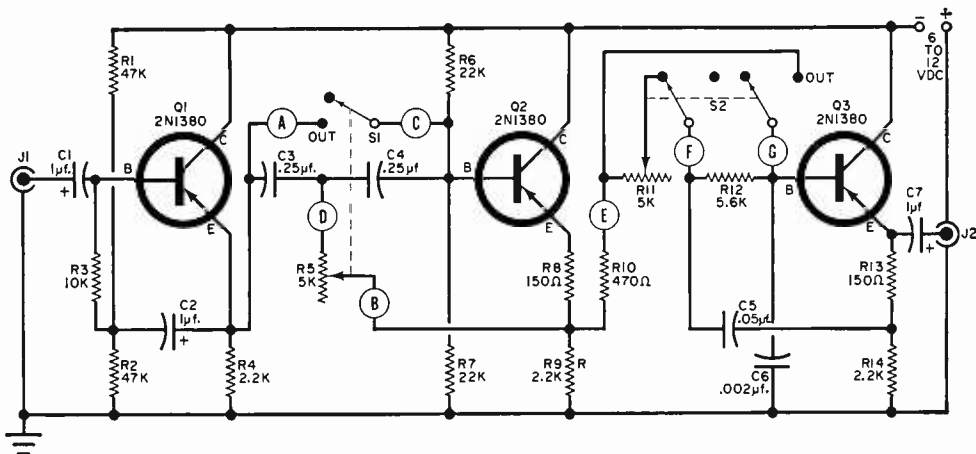

## PARTS LIST

*C1, C2, C7—1- $\mu$ f., 6-volt electrolytic capacitor*  
*C3, C4—0.25- $\mu$ f., 75-volt capacitor*  
*C5—0.05- $\mu$ f., 75-volt capacitor*  
*C6—0.002- $\mu$ f., 75-volt capacitor*  
*J1, J2—Phono jack*  
*Q1, Q2, Q3—2N1380 transistor*  
*R1, R2—47,000 ohms*  
*R3—10,000 ohms*  
*R4, R9, R14—2200 ohms*  
*R6, R7—22,000 ohms*  
*R8, R13—150 ohms*  
*R10—470 ohms*  
*R12—5600 ohms*

All  $\frac{1}{2}$ -watt  
fixed resistors

*R5, R11—5000-ohm potentiometer with d.p.d.t. switch, log taper (Centralab B-12 with KR-3 switch)*  
*S1, S2—D.p.d.t. switch mounted on rear of R5, R11*  
*4—Mounting brackets (Cambridge Thermionic Corp. 1963 or equivalent)*  
*1—2 $\frac{1}{4}$ "x2 $\frac{1}{4}$ "x4" aluminum case (Bud CU-2103 or equivalent)*  
*1—Circuit board (the author used an etched-circuit board (No. 101) which is available with three transistor sockets for \$1.25 from Demco, Box 16041, San Antonio, Texas 78216)*

prevent slipping while using the unit.

Now wire the controls (low-frequency filter *R5*, high-frequency filter *R11*, and jacks *J1* and *J2*). Follow the schematic diagram and photographs. The wires from these controls are connected to the coded points on the board corresponding to similar points on the schematic. Fasten the board to the brackets, and mount the entire assembly in the case.

**Testing.** Before applying voltage to the filter, check carefully for shorts or incorrect connections. Now connect the points marked plus and minus to a 6-to-12 volt battery or power supply. Note that the positive lead is grounded and common to both the input and the output.

Do not attempt to connect the filter in an automotive electrical system if the car has a negative ground. If the filter has to be used with a mobile system, strap a 6-volt dry cell to the rear of the filter box for a power supply. This will also help keep ignition noise out of the filter and eliminate any possibility of short-circuiting the electrical system.

The input and output connections may be made to the filter at any point in the circuit having a signal level of less than one volt. The best place to connect into a receiver would be at the volume control. Simply disconnect the wire from the center terminal (wiper) of the volume control and connect the input of the filter to this terminal. The wire is then connected to the filter output.

On a transmitter, the filter can be used with a crystal microphone, but volume will be reduced due to the loading effect of the 50,000-ohm input impedance of the filter on the high-impedance crystal. In a hi-fi system, the filter can be installed between the preamplifier and the power amplifier units.

**Using the Filter.** Turn the control knobs to the position that will clear up the maximum amount of noise without affecting the intelligibility of the speech or distorting the music any more than necessary. For communications work, especially under noisy conditions, you will find that the narrower bandpass settings are the most desirable. If condi-



tions on the band improve, you may want to set the filter for a wider response, but let the noise on the band dictate this. Should noise conditions clear up completely, or if you want an absolutely flat response, you can easily switch the filter completely out of the circuit by rotating the controls fully counterclockwise until the switches engage. The response will now be an essentially flat  $\pm 1$  db from 10 to 50,000 cycles. The filter itself has less than one per cent total harmonic distortion in its bandpass for any given setting of the controls.

The device can also be used for many special effects in tape recording, where it functions almost in an opposite manner to a reverberation unit or echo chamber. You can usually connect the filter into the tape recorder's recording preamplifier right at the record level controls. (Naturally, for stereo effects you will require two filters.) With the filter in the circuit, and the controls rotated clockwise, you will notice a marked

decrease of high and low frequencies. Since all the high-fidelity manufacturers are trying to open up the frequency response, you may well wonder how such a filter can be considered beneficial. Speech recorded through the filter will easily simulate telephone conversations, or communications radio reception. Other applications are certain to suggest themselves upon experimentation.

In a mobile installation, you will find this filter an ideal adjunct to your electronic equipment, be it broadcast, Citizens Band or amateur radio. Static noise is largely a high frequency function, and as you can sharply attenuate high frequencies with this filter, you can reduce static.

If you follow the diagrams, photographs and instructions, you will have no trouble putting the filter together and getting it to work properly. After you have used it for a while to silence static, or break through local noise with your transmitter, you'll probably find it indispensable. -30-

## NOW — BUILD ANY CIRCUIT IN ONLY 2 EASY STEPS WITH VEROBOARD KIT MODEL BK-6

### NO MORE ETCHING, WIRES OR TERMINALS!

Now — for the first time you can build circuits for ANY electronic project faster, easier and more economically than ever before and achieve real professional results.

Veroboard\* is the newest, most advanced method of circuit construction yet developed — with Veroboard you design your component layout directly on the board and solder... that's all there is to it!

This all-new Veroboard kit contains 6 Universal wiring boards and spot face cutter with instructions for use.

Order your kit today — save hours of construction time.

AVAILABLE FROM LEADING DISTRIBUTORS OR DIRECTLY FROM VERO ELECTRONICS.

\*Patented

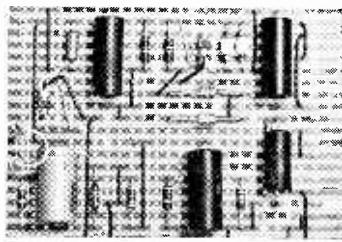

**STEP NO. 1**

Layout components on the back (plain) side of the Veroboard across the copper strips inserting leads into appropriate holes. You have now connected your components as required using the copper strips as your interconnectors. Leads may be soldered directly to the strips using a light, printed circuit type iron. Careful soldering will enable you to remove components and replace them if required.



**STEP NO. 2**

Break the circuit where required by breaking the copper strips with the Vero spot-face cutter provided in your kit. The cutter is a precision, hardened steel tool which has a pilot pin that fits into any hole, and two cutting edges. Simply turn the cutter several times and the copper strip in the area of the chosen hole will be removed. Your circuit is now complete.

NYS residents add 2% sales tax.

TO: VERO ELECTRONICS INC.

48 ALLEN BLVD., FARMINGDALE, N. Y.

PLEASE SEND VERO BK-6 KIT. I AM ENCLOSING CHECK (OR MONEY ORDER) FOR \$5.95.

NAME \_\_\_\_\_

ADDRESS \_\_\_\_\_

ZIP \_\_\_\_\_

H \_\_\_\_\_

CIRCLE NO. 31 ON READER SERVICE CARD



## THE COMPANION 6-METER TRANSMITTER

*Just two tubes and a power supply give you a 6-meter phone transmitter that's hard to beat for simplicity*

By CHARLES GREEN, W3IKH

**W**ANT TO KNOW how you can put a high-quality 6-watt, 6-meter phone signal on the air at a rock-bottom price? It's easy—just build this beautifully simple three-tube (counting the rectifier) "Companion Transmitter." Although this attractive little rig was designed to complement the "Simple Superhet for 6" which appeared in the April, 1963, issue of POPULAR ELECTRONICS and the 1964 ELECTRONIC EXPERIMENTER'S HANDBOOK, it can be used with any 6-meter receiving setup.

Designed for easy construction, the Companion Transmitter incorporates two 6CX8's, combination triode-pentodes (*V1b* and *V2b* have internally connected suppressor grids) ordinarily used in TV receivers. In the r.f. section, the triode portion of one 6CX8 (*V1a*) functions as a crystal overtone oscillator using standard FT-243 8-9 mc. crystals to produce an output in the 25-mc. region.

The pentode section of the 6CX8 (*V1b*) in the r.f. section is both a doubler and final amplifier; this type of circuit was chosen as it does not require neutralization. The plate circuit pi-network matches the r.f. output to an antenna of 50 to 72 ohms impedance.

As shown in the schematic on page 113, a second 6CX8 does duty as a speech amplifier-modulator. The mike input signal from *J4* is amplified by *V2a* and fed through *C15* to the grid of *V2b*. The signal is further amplified by *V2b* which modulates the r.f. output by means of the inductance of *T1* which is common to the plate circuits of both *V1b* and *V2b*. Only the primary winding of *T1* is used.

Metering of the final is provided by *M1*, connected to measure either grid or plate current using switch *S1*. Rotary switch *S2* is a d.p.d.t. type which switches the antenna and receiver and transmitter B-plus supplies when going



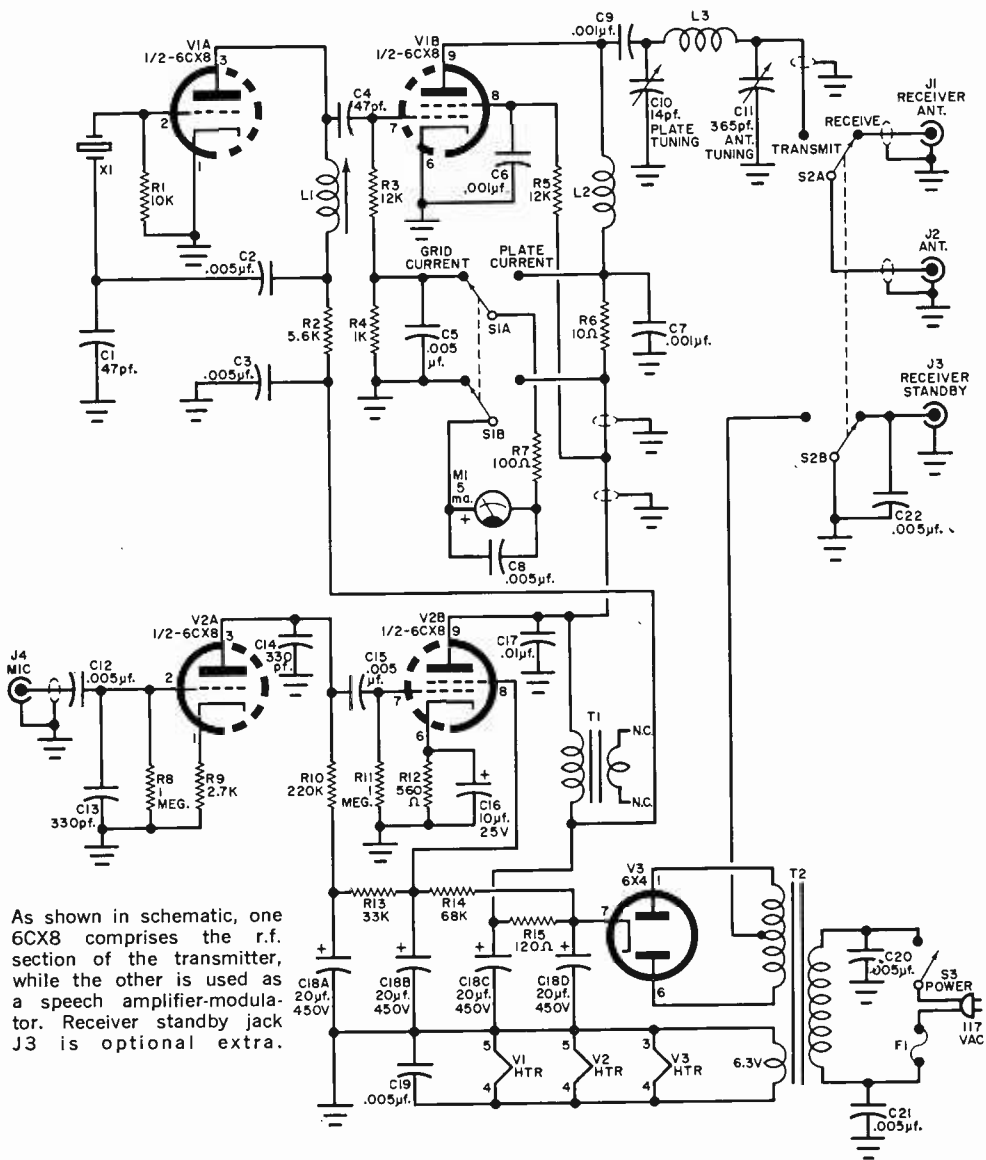

As shown in schematic, one 6CX8 comprises the r.f. section of the transmitter, while the other is used as a speech amplifier-modulator. Receiver standby jack J3 is optional extra.

and taped. In completing the Companion Transmitter, make sure the meter switch is labeled correctly: "G" for grid drive and "P" for plate current. Drill a  $\frac{3}{8}$ " hole in the top of the box for adjusting grid drive coil *L1*, and cut a row or two of holes in the back of the box cover for ventilation.

**Testing and Adjustment.** Insert the tubes in their sockets and a good active crystal in the front panel crystal socket. Place the cover on the transmitter, in-

stall a 52-ohm dummy load at jack *J2* and let the unit warm up for a minute or two. Set switch *S1* to measure grid current, and insert a plastic alignment screwdriver through the access hole in the cover onto the adjustment slug of coil *L1*.

Depress transmit switch *S2* and adjust the grid current to 2 ma. This adjustment should be made as quickly as possible to prevent damage to the tube. If the grid current adjustment cannot be

## PARTS LIST

- |   |   |
|---|---|
| <p><i>C1, C4—47-pf., 600-volt ceramic tubular capacitor</i></p> <p><i>C2, C3, C5, C8, C12, C15, C19, C20, C21, C22—0.005-<math>\mu</math>f., 1000-volt ceramic disc capacitor</i></p> <p><i>C6, C7, C9—0.001-<math>\mu</math>f., 1000-volt ceramic disc capacitor</i></p> <p><i>C10—14-pf. miniature variable capacitor (E. F. Johnson Type 160-107 or equivalent)</i></p> <p><i>C11—365-pf. variable capacitor (Lafayette 32-G-1103 or equivalent)</i></p> <p><i>C13, C14—330-pf., 1000-volt ceramic tubular or mica capacitor</i></p> <p><i>C16—10-<math>\mu</math>f., 25-volt electrolytic capacitor</i></p> <p><i>C17—0.01-<math>\mu</math>f., 1000-volt ceramic disc capacitor</i></p> <p><i>C18—Four-section electrolytic capacitor, 20 <math>\mu</math>f., 450 volts per section</i></p> <p><i>F1—1-amp type 3AG fuse in panel-mounting fuse holder</i></p> <p><i>J1, J2—Chassis-mounting coax receptacle (Amphenol 83-1R or equivalent)</i></p> <p><i>J3—Phono pin jack, single-hole mounting</i></p> <p><i>J4—Microphone connector, male, chassis-mounting (Amphenol 75-PC1M or equivalent)</i></p> <p><i>L1—3.3-<math>\mu</math>h. to 4.1-<math>\mu</math>h., miniature adjustable r.f. coil (J. W. Miller Part No. 20A336RBI)</i></p> <p><i>L2—7-<math>\mu</math>h. r.f. choke (Ohmite Z-50 or equivalent)</i></p> <p><i>L3—6 turns of B&amp;W "Miniductor" Type 3010 with <math>\frac{3}{8}</math>" leads (coil size <math>\frac{11}{8}</math>" x <math>\frac{3}{4}</math>" dia.)</i></p> <p><i>M1—5-ma. d.c. panel meter</i></p> <p><i>R1—10,000-ohm, <math>\frac{1}{2}</math>-watt resistor</i></p> <p><i>R2—5600-ohm, 2-watt resistor</i></p> <p><i>R3, R5—12,000-ohm, 1-watt resistor</i></p> | <p><i>R4—1000-ohm, <math>\frac{1}{2}</math>-watt resistor</i></p> <p><i>R6—10-ohm, <math>\frac{1}{2}</math>-watt resistor</i></p> <p><i>R7—100-ohm, <math>\frac{1}{2}</math>-watt resistor</i></p> <p><i>R8, R11—1-megohm, <math>\frac{1}{2}</math>-watt resistor</i></p> <p><i>R9—2700-ohm, <math>\frac{1}{2}</math>-watt resistor</i></p> <p><i>R10—220,000-ohm, <math>\frac{1}{2}</math>-watt resistor</i></p> <p><i>R12—560-ohm, 1-watt resistor</i></p> <p><i>R13—33,000-ohm, 1-watt resistor</i></p> <p><i>R14—68,000-ohm, 1-watt resistor</i></p> <p><i>R15—120-ohm, 1-watt resistor</i></p> <p><i>S1—D.p.d.t. slide switch</i></p> <p><i>S2—D.p.d.t. rotary switch, non-shorting (Malory Type 3222J)</i></p> <p><i>S3—S.p.s.t. toggle switch</i></p> <p><i>T1—Audio output transformer; primary, 10,000 ohms, secondary 4 ohms (Stancor A-3879 or equivalent)</i></p> <p><i>T2—Power transformer; primary, 117 volts; secondaries, 460 volts CT @ 50 ma., 6.3 volts @ 2.5 amp (Thordarson 24R11-U)</i></p> <p><i>V1, V2—6CX8 vacuum tube</i></p> <p><i>V3—6X4 vacuum tube</i></p> <p><i>X1—8-<math>\mu</math>c. transmitting crystal</i></p> <p><i>1—4<math>\frac{1}{2}</math>" x 6" x 8" aluminum utility box (LMB 146 or equivalent)</i></p> <p><i>1—4<math>\frac{1}{2}</math>" x 8" aluminum plate for chassis shelf</i></p> <p><i>2—9-pin miniature tube socket</i></p> <p><i>1—7-pin miniature tube socket</i></p> <p><i>1—Xtal socket for FT-243 crystal holders</i></p> <p><i>Misc.—Aluminum angle stock, terminal strips, RG-58/U cable, shielded audio cable, hookup wire, hardware, solder lugs, grommets, etc.</i></p> |
|---|---|

made, change the crystal for a more active one. Set the transmit switch to standby position and move the meter switch to indicate plate current. Rotate the antenna tuning control to the maximum counterclockwise position (full capacity) and depress the transmit switch. Tune the plate for maximum current dip, then adjust the antenna and plate controls alternately until the current is 22 ma. The last adjustment should be made with the plate tuning control. At this point, the transmitter is fully loaded.

Check the grid current again, and reset *L1* if necessary for a 2-ma. reading. These tune-up procedures should also be used for on-the-air operation with an antenna connected in place of the dummy load.

Your receiver can be used to check modulation with a high-output crystal mike connected to *J4*. The radiation from the dummy load should be sufficient for this test. In the interests of economy and simplicity, the speech amplifier-modulator of the Companion

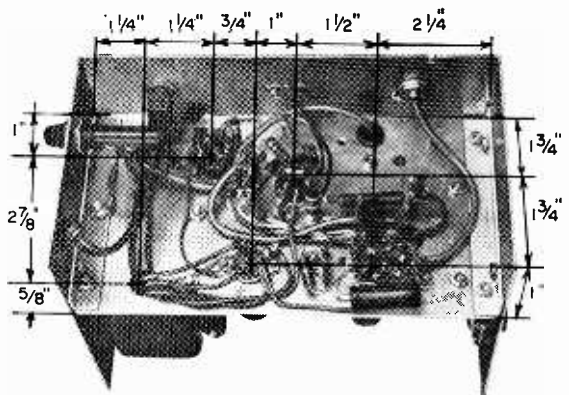
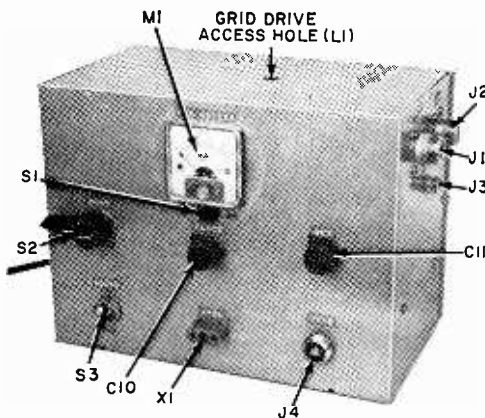

The dimensions above show approximate component spacing.

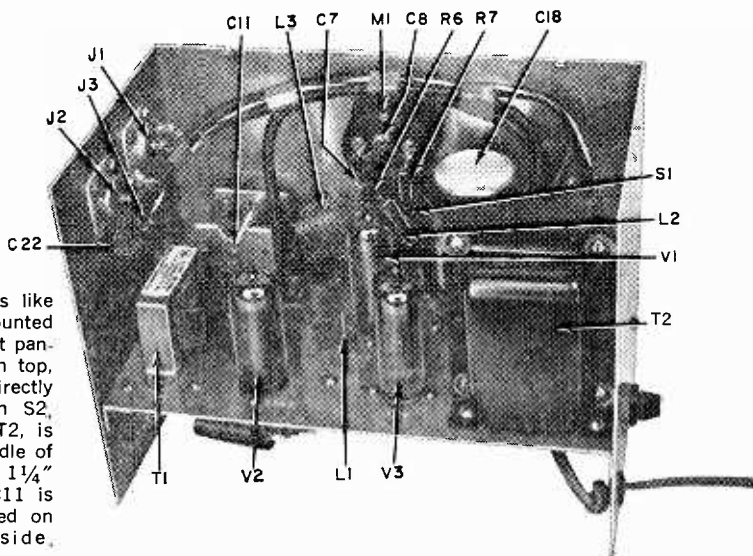

Top of rig looks like this, with M1 mounted at center of front panel and 1/2" from top, S1 and C10 directly below it. Switch S2, hidden behind T2, is mounted in middle of panel and about 1 1/4" in from side; C11 is similarly mounted on the opposite side.

Transmitter was limited to a single tube. For this reason, a high-output mike must be used for a good percentage of modulation. Strongly recommended is the Astatic Model 150 recorder mike which has an output of -44 db. It is readily available and sells for under \$4.00.

**"Simple Superhet" Conversion.** If you plan to use the "Simple Superhet for 6" as the station receiver, a few simple modifications will give you improved reception and single-switch operation.

A remote control jack and standby switch (J3 and S2 in the drawing below) are installed on the side of the receiver

cabinet. The ground lead of the receiver transformer is then connected as shown. This arrangement permits transmitter switch S2 to control the receiver. More B-plus for the receiver can be obtained by replacing the selenium rectifier (see the April, 1963, issue) with a 400-PIV, 450-ma. silicon unit.

The most-used portion of the 6-meter band, 50-51 mc., can be made to cover more of the receiver dial by connecting a 10-pf., 600-volt ceramic tubular capacitor between the stators of C1 and C2. Readjust the bandset capacitor C2 and calibrate the receiver as described in the original article. -30-

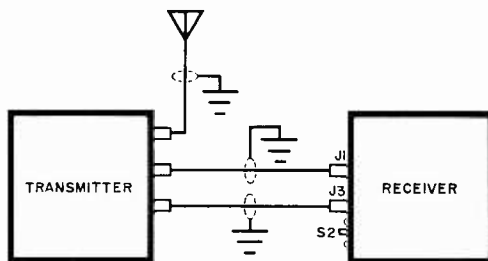
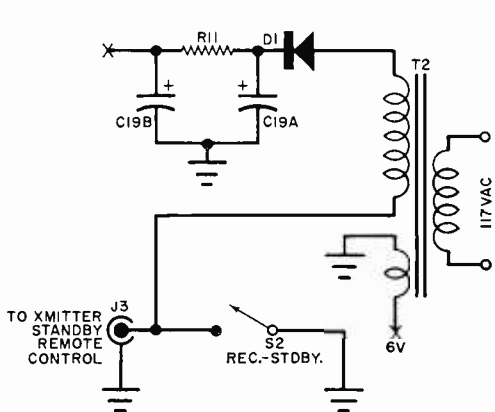

Receiver is modified as shown at left to permit single switch operation of station. Connections between the units are for antenna and power switching.

# SOUP UP THAT AM BROADCAST RECEIVER

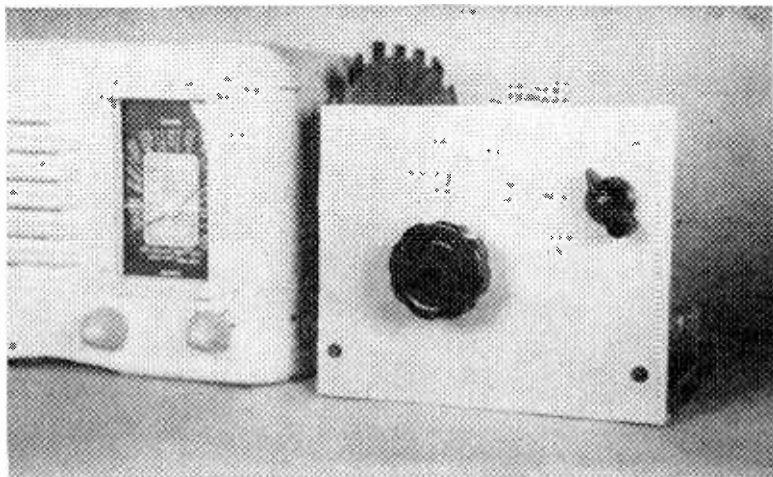

By F. J. BAUER, Jr., W6FPO

***Want to improve the sensitivity of your small receiver?***

***Here are several ideas that really work***

**I**F BROADCAST BAND DX'ing is your cup of tea, you are aware of the shortcomings of the "All-American 5" and the built-in loop antenna. As the loop is not just a signal catcher but also a part of the first tuned circuit of the receiver, you can't tamper with it without altering receiver alignment.

**Simple Coupler.** Will a coupler and long-wire antenna improve your reception? They certainly will, and here's a quick-and-dirty test to prove the point. String up a good antenna, the longer (at least 50 to 100 feet) and higher the better. Connect one end of this wire to a four- or five-turn coil of wire that you wind around your hand. The other end of the coil goes to a good water-pipe ground (see Fig. 1, on page 120). Now tune in a weak station and bring the coil of wire closer to the loop antenna on the receiver. See? The signal strength increases, and the weak station comes in strong. The next step is to build something more permanent.

**A Better Coupler.** A better antenna coupler tunes the antenna to the frequency of the station you want to hear. It consists of an adjustable ferrite coil with a series capacitor that can be switched in or out of the circuit (Fig. 2). With the capacitor in the circuit, the upper half of the broadcast band is covered, and with the capacitor out of the circuit, the lower half is covered. You can adjust the ferrite coil to obtain optimum results.

**Still Better.** A more elaborate, more flexible coupler will work with any antenna length (Fig. 3). The author utilized parts available in the junk box, using coil *L2* for maximum coupling to the receiver. This coil was salvaged from an old receiver as was capacitor *C1*, made by paralleling the three sections of an old tuning capacitor.

**Adjusting the Couplers.** The first thing to do is determine the amount of "coupling" that will best suit your own  
(Continued on page 120)

# FREE CATALOG.

*250 "Do-It-Yourself"  
Electronic Kits At  
Up To 50% Savings*

**WHY BUILD HEATHKIT ELECTRONICS?** A desire for top-quality products at 50% savings, to be sure. But it goes beyond that. The reason people choose Heathkit is pride. Not just the pride of owning something new, but something a bit better that you have created yourself! From watching your Heathkit grow and take shape from your own efforts. It's a labor of love and a lot of fun. The large pictorial diagrams and simple, step-by-step instructions make it easy. And when you finish and turn it on you'll know that unique self-satisfaction that comes with "do-it-yourself." You will have joined the millions of people, from ages 11 to 79, people with no special electronic skills or knowledge, who successfully build Heathkits. People like you! Give it a try. Your FREE Heathkit catalog is waiting for you now.

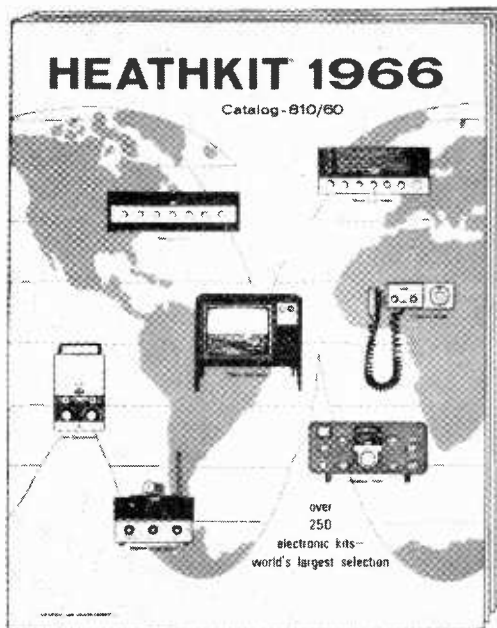

## World's Largest Selection Of Electronic Kits



**NEW** Low Price On Heathkit  
21" Color TV . . . Only \$375.00



**NEW** Transistor FM Stereo  
Tuner That Assembles In 6  
Hours Or Less . . . Only \$49.95



**NEW** Low Prices On  
Many Heathkit Stereo/Hi-Fi  
Components

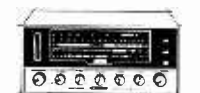

**NEW** Deluxe Shortwave  
Radio . . . Only \$84.95



**NEW** 23-Channel, 5-Watt  
All-Transistor CB Transceiver . . .  
Only \$89.95

- ★ See The Vast Selection Of Portable And Table Model AM, FM and Shortwave Radios
- ★ See The Famous Heathkit/Thomas Transistor Electronic Organs
- ★ See A Complete Selection Of Home & Hobby Items . . . Intercoms, Garage Door Opener, Automotive Kits, Tools, Color TV Sets
- ★ See All Heathkit Stereo/Hi-Fi Components . . . Tuners, Amplifiers, Speakers, Turntables, Cartridges, Furniture
- ★ See The Full Complement Of Heath Marine Electronics
- ★ See The Complete Line Of Citizen's Band Radio Gear . . . Transceivers, Walkie-Talkies, Accessories
- ★ See The Wide Selection Of Heath Educational Kits For Home Or Classroom Study
- ★ See The World's Largest Line Of Amateur Radio Gear
- ★ See The Full Line Of Heathkit Lab & Test Instruments For Home Workshop, Industrial & Educational Use



**MAIL  
COUPON  
FOR YOUR  
FREE  
COPY** ▶

**HEATH COMPANY, Dept. 110-9**  
Benton Harbor, Michigan 49023  
In Canada: Daystrom, Ltd., Cooksville, Ontario

Please send FREE 1966 Heathkit Catalog

Name \_\_\_\_\_

Address \_\_\_\_\_

City \_\_\_\_\_ State \_\_\_\_\_ Zip \_\_\_\_\_

Prices & specifications subject to change without notice.

CL-215





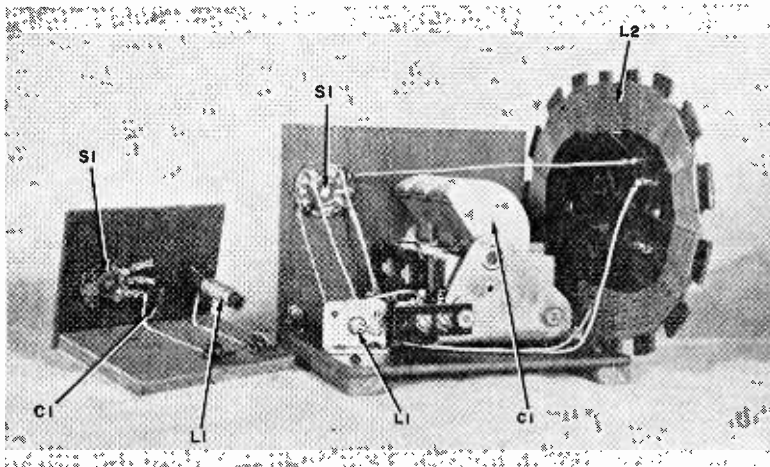

Looking at the backs of the two couplers diagrammed in Figs. 2 and 3, it's obvious that there isn't any complex wiring to be done. Use point-to-point wiring throughout, build panels of Masonite, woodscrap.



Fig. 1. Simple coupler consists of four or five turns of wire connected to a long (50'-100') antenna and good ground. To use, place coil near receiver's antenna.

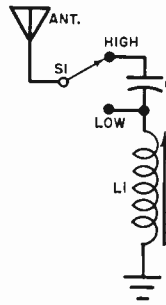

Fig. 2. Better coupler has s.p.d.t. switch to insert or remove 100-pf. capacitor C1. Ferrite antenna coil L1 fine-tunes antenna.

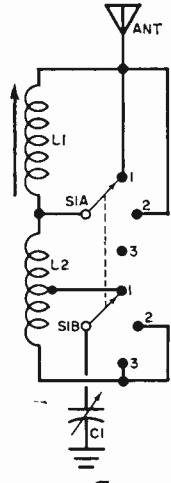

Fig. 3. This coupler is more flexible. A double-pole, 3-position switch selects portion of band to be heard, .001- $\mu$ f. capacitor C1 fine-tunes.

system. ("Coupling" refers to the placement of your antenna coupler with relation to your receiver antenna coil.) There are two ways to do this. If you have a VTVM, connect it to the a.v.c. bus in your receiver. Now move the coupler closer to your antenna coil as you observe the meter. The voltage will increase—to a point—and then start to fall off. The best location for the coupler is where it was at that highest voltage point.

A simpler way to achieve maximum coupling efficiency is to place the antenna wire near a fluorescent fixture and couple for maximum noise in the receiver loudspeaker. In either case, do not increase the coupling beyond the optimum point, for over-coupling serves only to introduce interference with no increase in gain.

**Using the Couplers.** To use the coupler shown in Fig. 2, first select the switch position (capacitor C1—a 100-pf. unit in this coupler—in or out) that corresponds with the frequency you want to hear, and then adjust the slug in L1

for best reception. Coil L1 in Figs. 2 and 3 is an Olson Radio No. L-75.

To use the coupler shown in Fig. 3, tune in a station near 540 kc., with the plates of capacitor C1 (.001  $\mu$ f.) fully meshed, and adjust the slug in coil L1 for maximum volume. Then you can use switch S1 to rough-tune the coupler, and capacitor C1 to fine-tune. The switch positions and frequency ranges are as follows:

Switch Position	Frequency
1	540- 870 kc.
2 (center tap)	740-1200 kc.
3	1100-1650 kc.

An outdoor antenna will improve any "All-American 5." An antenna coupler will permit you to use an outdoor antenna with your receiver. -30-

# THE 6 METER 7 AND 2 PREAMP

***A high-gain, low-noise transistor preamp for 6—for just \$7 and 2 hours of labor***

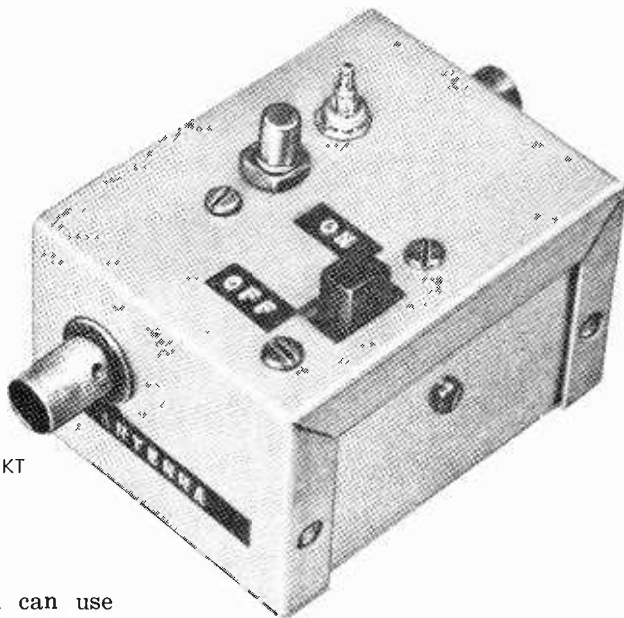

By **JOSEPH TARTAS, W2YKT**

**I**F YOU work 6 meters and can use more r.f. gain on receive along with a reduction in signal-to-noise ratio (and who can't?), the "6 Meter 7 and 2 Pre-amp" is for you. Heart of this little one-evening project is a new low-noise germanium transistor, the 2N2188, made by Texas Instruments. At 50 mc., the preamp has a measured 6 db noise figure, which represents a maximum sensitivity (the smallest signal it can receive) of about 1.5  $\mu$ v. Inserted between the antenna and receiver input, it can boost signal level by at least 12 to 15 db.

Other advantages of the preamp are that it is compact and self-powered—at a battery drain of 4 ma., the battery should last for nearly its shelf life. Although the unit was designed for 50-ohm input and output, it will work well at impedances up to 300 ohms without much deterioration in performance. Lastly, the total cost is only about \$7.00.

The 6-meter preamp is housed in a

small 1 $\frac{3}{8}$ " x 2 $\frac{1}{2}$ " x 2 $\frac{3}{4}$ " Minibox, and straight-line, minimum length leads are employed. Carefully follow the layout as shown in the photos. Drill holes in the box for mounting r.f. connectors *J1* and *J2* (use the type you presently employ for convenience), the on-off switch *S1*, the transistor socket, and the output coil form (*L1* and *L2*).

**The Coils.** Wind input coil *L3* with #14 wire; consisting of five turns with an i.d. of  $\frac{3}{8}$ ", it should have an approximate length of  $\frac{1}{2}$ ". Support it by soldering the center turn directly to the center conductor of the input r.f. connector. The grounded end is connected to a lug held to the chassis with a screw and bolt. The same lug also serves as a ground for the 47-pf. capacitor (*C1*) and resistors *R2* and *R3*.

The output coil is wound with the three-turn secondary (*L2*) at the cold

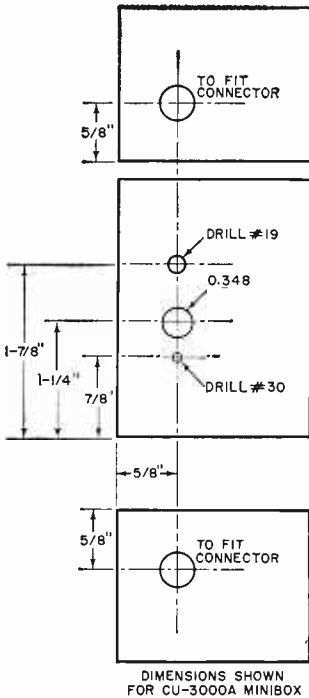

DIMENSIONS SHOWN FOR CU-3000A MINIBOX

### PARTS LIST

- B1—9-volt transistor battery
- C1—47-pf. ceramic disc capacitor
- C2, C3, C5—0.001- $\mu$ f. ceramic disc capacitor
- C4—18-pf. ceramic disc capacitor
- J1, J2—R.f. connector
- L1, L2—8 turns and 3 turns, respectively, of #24 wire wound on Cambridge Thermionic slug-tuned coil form PLST/2C4L/P
- L3—5 turns of #14 wire, i.d.  $\frac{3}{8}$ " , length  $\frac{1}{2}$ "
- Q1—2N2188 transistor (Texas Instruments)
- R1—3900-ohm,  $\frac{1}{2}$ -watt resistor
- R2, R3—1000-ohm,  $\frac{1}{2}$ -watt resistor
- RFC-1—5.6- $\mu$ h. miniature r.f. choke (J. W. Miller 9330-18 or similar)
- S1—S.p.s.t. slide switch
- 1— $1\frac{1}{8}$ " x  $2\frac{3}{8}$ " x  $2\frac{3}{4}$ " Minibox (Bud CU-3000A)
- 1—Transistor socket (Elco 3304 or equivalent)
- 1—Battery clip (Cinch-Jones 5D or equivalent)

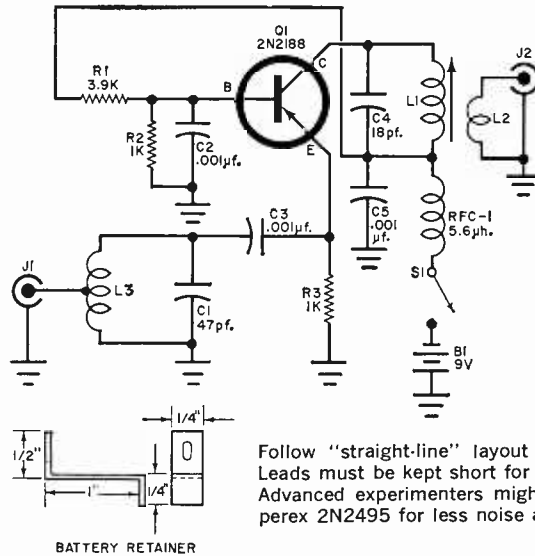

Follow "straight-line" layout shown here. Leads must be kept short for good results. Advanced experimenters might try an Amperex 2N2495 for less noise at lower cost.

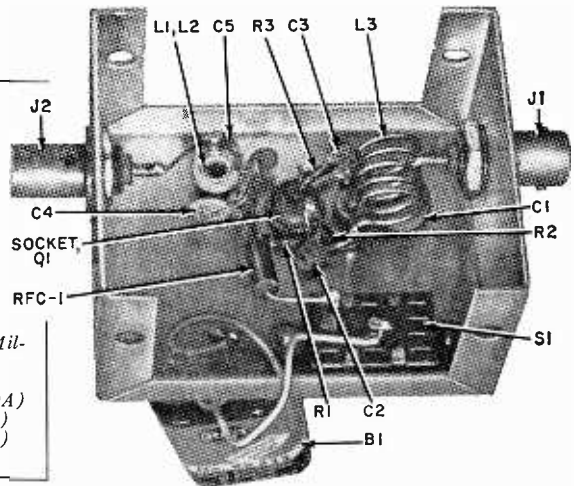

end of the primary (the end of the coil form closest to the box top). The primary ( $L1$ ) has eight turns. Wind the coils in the same direction, connecting the top leads to  $Q1$ 's collector and to  $J2$ , respectively. Both are wound on the slug-tuned, .2"-o.d. (coil winding area) coil form given in the Parts List. As specified, this form comes with terminals and slug designed for VHF applications. It is available from suppliers in large cities, or from most parts suppliers on special order. Another source is Newark Electronics Corp., 223 West Madison St., Chicago 6, Ill.

**Tuning the Preamp.** To peak the preamp, simply insert the transistor in the socket—after checking first to make sure battery polarity is correct—and tune the output coil for maximum noise or signal level in the middle of the band. If necessary, the input coil can also be peaked by squeezing the turns together or gently pulling them apart. Since the bandwidth of the preamp is about 2.5 mc., adjustment is not critical. For best results, you may want to peak the unit in the middle of the portion of the 6-meter amateur band most used in your own area.

# CHAPTER

## 6 TEST EQUIPMENT PROJECTS

Because of the commercial availability of test equipment—either in kit form or prewired—projects for the home constructor must be instruments he can't buy. This is the philosophy used in selecting projects for the Fall Edition of the 1965 ELECTRONIC EXPERIMENTER'S HANDBOOK.

The "Field-Effect Transistor Voltmeter" (page 127) is one of the first—if not the very first—construction project to take advantage of the unusual characteristics of the field-effect transistor. This device is simple to build and calibrate, and has an input resistance comparable to that of a VTVM. The "SCR Tester" (page 126) is a companion piece to the "Automatic Diode Checker" (in the 1963 Edition of the ELECTRONIC EXPERIMENTER'S HANDBOOK). It could also be labeled "automatic" since it checks operating characteristics of the gate as well as checking for opens and shorts.

This chapter is rounded off with several short items and some of the best "Tips and Techniques" from past issues of POPULAR ELECTRONICS.

124	HYBRID CIRCUIT FOR TRANSISTOR POWER.....Roy E. Pafenberg
126	SCR TESTER.....T. E. Hopkins
127	FIELD-EFFECT TRANSISTOR VOLTMETER.....Jeff H. Taylor
131	MULTIPLE METER TEST SET.....Roy E. Pafenberg
132	MULTI-OUTPUT ZENER VOLTAGE REGULATOR.....Harold Reed
133	BEST OF TIPS AND TECHNIQUES.....

# Hybrid Circuit for

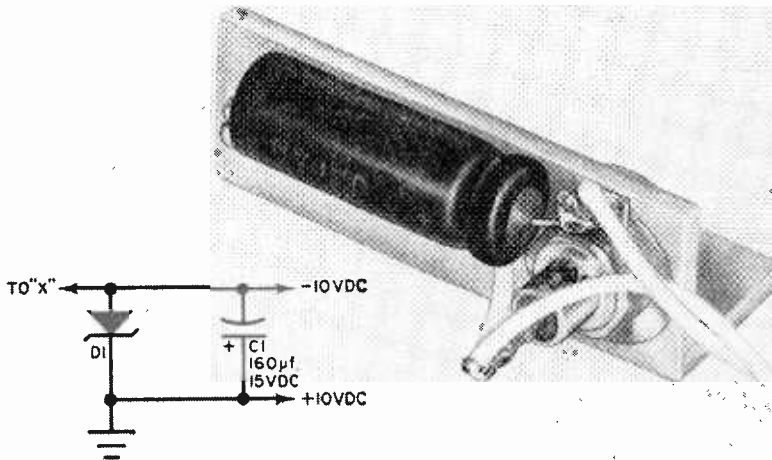

Schematic for zener diode version is shown above. Current increases through diode as load current goes up. Diode can safely handle one ampere.

Good heat sink is prime requirement of zener regulator above. No insulation is required between diode, bracket. Capacitor connects to standoff.

**Put that high-voltage bench supply to work powering your transistor projects— a simple addition gives you a handy low-voltage tap**

By **ROY E. PAFENBERG, W4WKM**

AN A.C.-OPERATED power supply furnishing a range of commonly used voltages is a "must" for experimental electronics work. These "bench supplies" range from very elaborate commercial units to those built on open chassis from junk box parts. Most such supplies were designed for use with vacuum tube circuits, but with the popularity of transistors on the upswing, they have limited application.

One answer to this problem can be found in the assemblies shown here. Either of the units will convert a conventional B-plus supply to furnish suit-

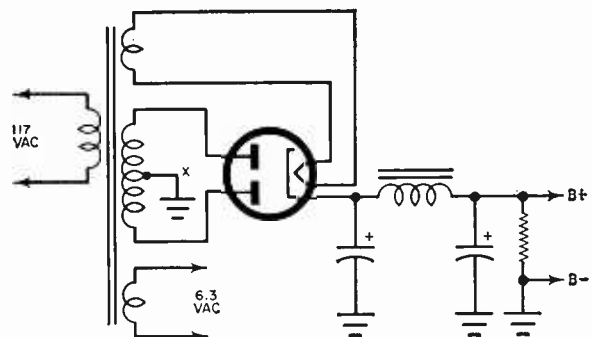

Typical supply is shown in schematic (right). Attach regulator at "X." Disconnect tap, connect to low-voltage regulator input, and then ground the regulator.

# Transistor Power

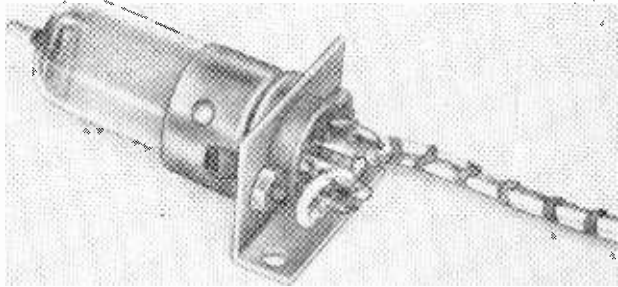
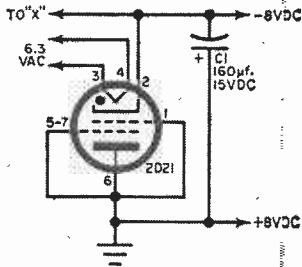
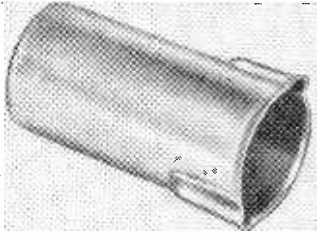

Schematic diagram of 2D21 regulator. Higher voltages can be obtained by adding additional tubes, but increase voltage rating of C1 appropriately as well.

Tube regulator is assembled on bracket of bent-up aluminum sheet scrap. This mounts under supply chassis. Capacitor C1 is not shown in photograph.

able low-voltage outputs for transistor work. A peculiarity of this conversion is that the current that may be drawn from the low-voltage tap is limited to a value somewhat less than the combined bleeder—high-voltage output current. This is no drawback with tube or tube-and-transistor equipment, however, and another bleeder can always be added to the high-voltage end of the supply if you need more current while using the low-voltage tap exclusively.

**How It Works.** If you insert a resistor in series with the transformer center-tap in a conventional power supply, a voltage (determined by the current in the circuit) will be developed across the resistor. This is how negative bias voltages have been obtained for years. When you insert a *zener diode* in series with the center tap, the rectified voltage across it causes the diode to conduct, and the voltage drop remains constant over a wide range of bleeder and external load current of the B-plus output. While the voltage of the diode is subtracted from the output, it is negligible when considered as a percentage of the output.

The second version of this circuit uses

a cold-cathode, gas-filled 2D21 thyatron. As the voltage drop of a gas tube is fairly independent of current variation, a well-regulated voltage is developed. The 2D21 is inexpensive, which adds to the appeal of this version.

**Building the Regulators.** Construction details are shown for assemblies designed for installation under the chassis of the supply. In the diode version,  $\frac{3}{4}$ -inch aluminum angle stock is used to mount diode *D1* and capacitor *C1*. A standoff insulator is used for one end of the capacitor. No insulation is required for the diode stud, as in the usual grounded bias supply. The aluminum provides a good heat sink for the diode, which is an International Rectifier 10-watt, 10-volt unit. You can substitute at will, but do not exceed the diode current ratings.

In the 2D21 version, bend up a small bracket from scrap aluminum for the tube socket. You can, if you wish, increase the voltage output of the 2D21 circuit by adding additional tubes in series, but be sure to increase the working voltage rating of the capacitor if you make such a change.

-50-

# SCR TESTER

By T. E. HOPKINS

*There's no easy way of testing an SCR  
but this handy gadget solves the problem*

**I**NCREASING commercial and domestic use of silicon controlled rectifiers (SCR's) in such popular devices as light dimmers, for power tool speed control, etc., has created a need for a simple, quick, and reliable method of checking the condition of those suspected of being faulty.

An SCR is a four-layer semiconductor device with two main conducting termi-

nals and a gate terminal. It contains junctions that are intended to block all current in a reverse direction, block current flow in the forward direction under normal or ungated conditions, and allow forward current flow when the gate is energized or triggered. Thus, it is possible for an SCR to break down in either the forward or reverse direction or both. It is also possible for the gate connection to become either shorted or open. Therefore, it is *not* possible to determine the condition of an SCR by simple ohmmeter tests as may be done with a rectifier or even, to some extent, with a transistor.

The device described in this article will test both forward and reverse breakdown and gate operation. Transformer *T1* provides a 25-volt, r.m.s. source of a.c. to the circuit. This voltage is alternately applied in the forward and reverse directions across the anode-cathode connections of the SCR. If initial breakdown is present in either direction, current will flow in that particular direction and the current will be detected by either the "Forward" or "Reverse" lamps.

*(Continued on page 139)*

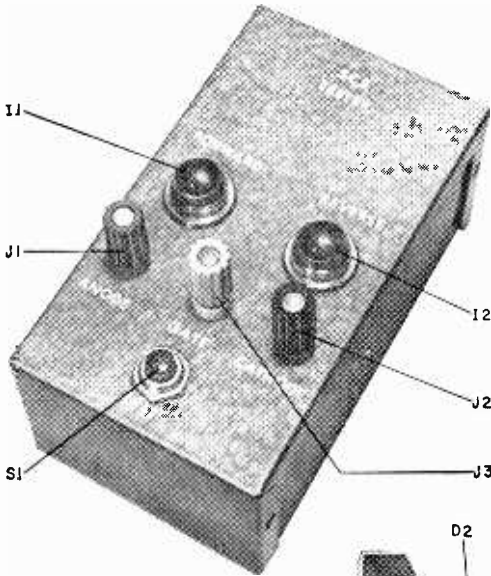

All of the components can be readily fitted into a convenient aluminum box. The wire from switch S1 to center binding post J3 ("Gate") may not seem visible, but it's really there. Numerous inexpensive 24-25 transformers are available as substitutes for the filament transformer called out in Parts List on page 139.

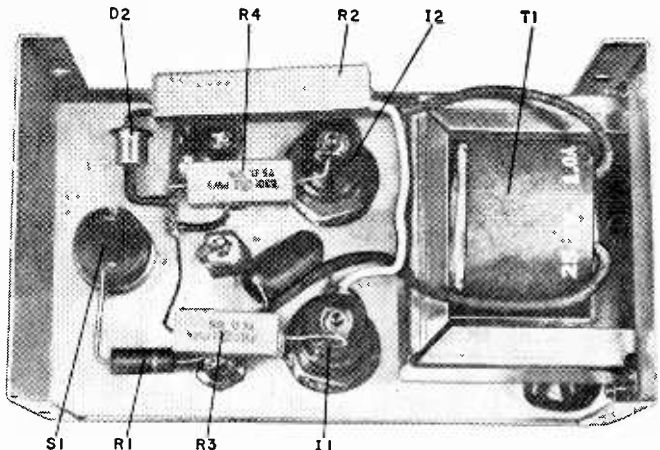

# ADVANCED EXPERIMENTER'S CORNER

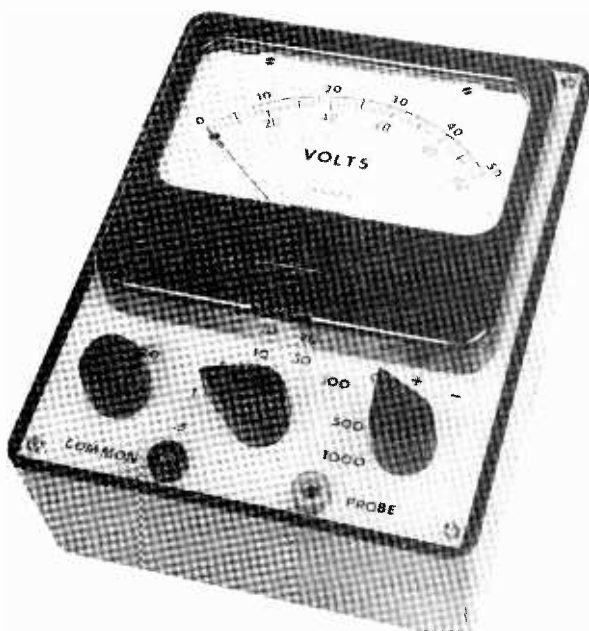

## FIELD-EFFECT TRANSISTOR VOLTMETER

*Extraordinarily high  
input impedance,  
portability and accuracy,  
with a single transistor*

By **JEFF H. TAYLOR**, Texas Instruments, Inc.

**T**HE field-effect transistor has steadily gained in popularity due to its ability to act like a vacuum tube. With increased popularity, the price of such transistors has fallen and is now within the budget range of most experimenters. The 2N2498 is currently being sold for \$12.75, and the new 2N3330 for \$10.82. The transistor voltmeter described in this article is similar in many respects to

a VTVM, but uses, instead of a vacuum tube, a single unipolar field-effect transistor—the 2N2498.

The unipolar transistor—unlike its bipolar brothers—exhibits extremely high input impedance and some of the other characteristics that might be attributed to a vacuum tube, specifically a pentode. Because of these characteristics, a voltmeter can be designed with a single



transistor and a bare minimum of parts. As the specifications on the next page show, the field-effect transistor voltmeter is small, lightweight, and has a battery life equal to the shelf life of the mercury cells used to power it.

Technically, the voltmeter uses a field-effect transistor in a source-follower configuration (similar in many respects to the familiar cathode-follower arrangement used with vacuum tubes). The voltage gain of the final circuit is less than unity, and varies with changes of the small-signal common-source forward transfer admittance and other circuit impedances.

**Circuit Theory.** The basic voltmeter circuit is shown in the small diagram in the upper right-hand corner of the next page. To analyze it, assume that a zero potential is established between points *A* and *B* and that current will flow through the transistor and resistor  $R_s$ . This places point *C* negative with respect to point *B*. Combination resistors  $R_a$  and  $R_b$  can be adjusted to provide a potential at point *D* equal to the potential at point *C*. The meter will now indicate zero. If a negative potential is applied to the input (*A-B*), the current through the transistor and resistor  $R_s$  will increase and point *C* will become more negative—causing a meter reading proportional to the potential difference between points *A* and *B*.

The input resistance of this circuit can be extraordinarily high since it is determined by the *gate-to-channel* leakage of the field-effect transistor. ("Channel" refers to the conducting path between the "source" and the "drain.") Obviously, this circuit will not work in actual practice since the open gate would permit static potentials at point *A* to cause the meter needle to wander. A practical version of this basic circuit is shown in the large schematic diagram and construction photograph.

**A Practical Circuit.** Through a rather modest arrangement of switches and resistors, a single field-effect transistor voltmeter can be built possessing the detailed specifications outlined at the bottom of page 129. The input impedance of this voltmeter is determined by the series combination of resistors  $R1$  through  $R9$ . To provide protection from transient overload or stray a.c. voltage injection, the filter consisting of  $C1$  and  $R10$  has been introduced. Diode  $D1$  has been wired across the meter so that the movement current can be limited to about  $1\frac{1}{2}$  times the full-scale deflection value. Although this circuit was designed using the 2N2498 field-effect transistor, the 2N3330 will perform equally well, and so will the 2N2497, 2N2499, 2N3329 and 2N2500.

Since the over-all accuracy of the  
(Continued on page 140)

The voltmeter is mounted in a black Bakelite meter box available at most radio supply houses. The circuit components are mounted on a piece of perforated phenolic board which is attached to the back of meter  $M1$  with nuts on the meter input terminals. Although layout is not critical, care should be taken to insure that leakage paths do not develop in input circuit.

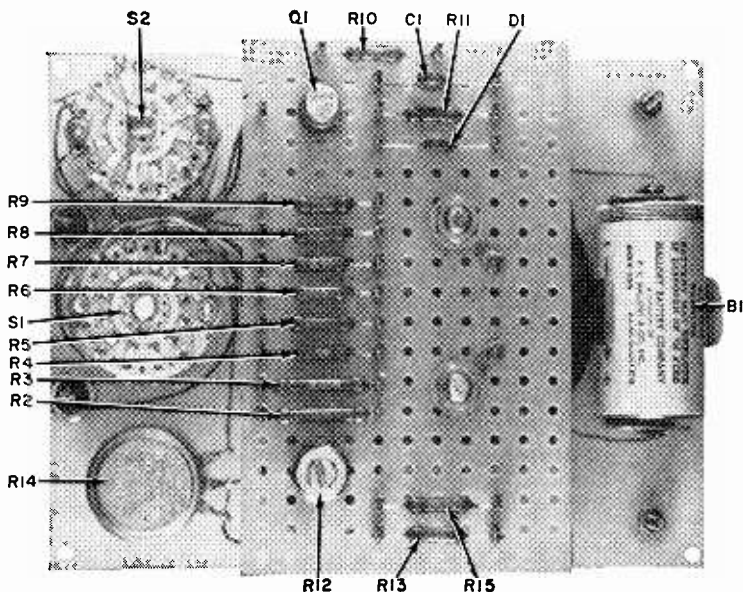

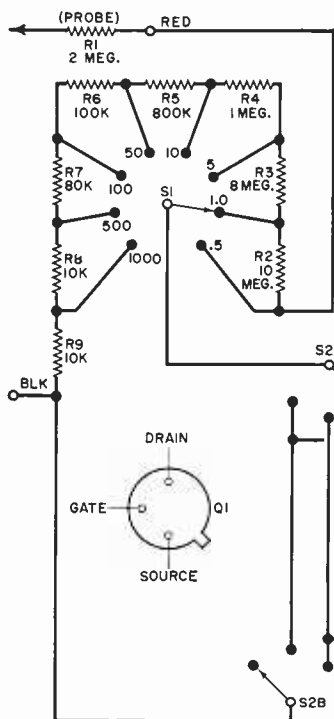

The theoretical circuit at right demonstrates the operation of the practical circuit below (see text for details).

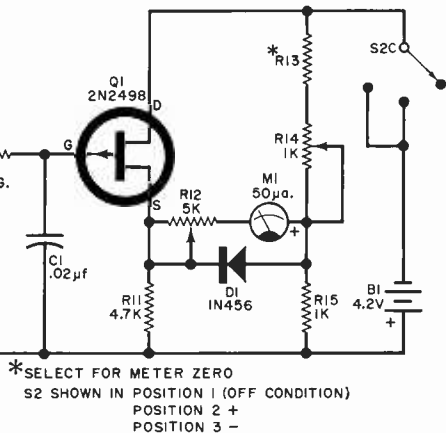
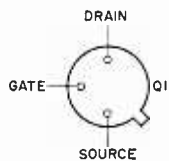
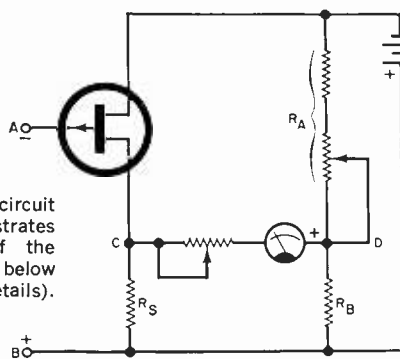

### PARTS LIST

- B1—4.2-volt mercury battery (Mallory TR233 or equivalent)
- C1—0.02- $\mu$ f., 200-volt capacitor
- D1—1N456 silicon diode
- M1—0-50 microampere meter (Simpson Model 29 or equivalent)
- Q1—2N2498 field-effect transistor (Texas Instruments)
- R1—2-megohm (or 1.8- or 2.2-megohm),  $\frac{1}{2}$ -watt resistor, 10%
- R2—10 megohms } 1-watt resistors, 1%
- R3—8.0 megohms } (Aerovox CPX-1 or equiv.)
- R4—1.0 megohm
- R5—800,000 ohms }  $\frac{1}{2}$ -watt resistors, 1%
- R6—100,000 ohms } (Aerovox CPSX  $\frac{1}{2}$  or equiv.)
- R7—80,000 ohms
- R8, R9—10,000 ohms

- R10—1.0-megohm,  $\frac{1}{2}$ -watt resistor, 10%
- R11—4700-ohm,  $\frac{1}{2}$ -watt resistor, 10%
- R12—5000-ohm potentiometer with lock
- R13—1000- to 5000-ohm resistor—see text
- R14—1000-ohm potentiometer
- R15—1000-ohm,  $\frac{1}{2}$ -watt resistor, 10%
- S1—1-pole, 8-position rotary switch (Centralab PA-1001 or equivalent)
- S2—3-pole, 3-position rotary switch (Centralab PA-1007 or equivalent)
- 1—Battery holder (Keystone #173 or equivalent)
- 2—Banana jacks, one red, one black
- 1—Black plastic multimeter case (approx. 6 13/16" x 5 9/32" x 2 5/16") or similar
- Misc.—Set of test leads with banana plugs, knob for zero control, perforated phenolic board

### SPECIFICATIONS

**Accuracy** Determined by meter movement used. Accuracy of instrument shown is within  $\pm 2\%$  of full scale.

**Battery Life** Essentially shelf life.

**Input Impedance** 22 megohms on any range (including 2-megohm probe).

**Power Consumption** Approximately 5 mw.

**Power Supply** 4.3-volt mercury battery.

**Voltage Range** 0.5 volt to 1000 volts. Eight ranges selected with front panel switch. Full-scale readings of: 0.5, 1.0, 5.0, 10, 50, 100, 500, and 1000 volts.

**Warm-Up Time** Zero.

**Weight** Approximately 2  $\frac{1}{4}$  lb. with battery.



## Why We Make the Model 211 Available Now

Although there are many stereo test records on the market today, most critical checks on existing test records have to be made with expensive test equipment.

Realizing this, HiFi/STEREO REVIEW decided to produce a record that allows you to check your stereo rig, accurately and completely, just by listening! A record that would be precise enough for technicians to use in the laboratory—and versatile enough for you to use in your home.

The result: the HiFi/STEREO REVIEW Model 211 Stereo Test Record!

## Stereo Checks That Can Be Made With the Model 211

- ✓ Frequency response — a direct check of eighteen sections of the frequency spectrum, from 20 to 20,000 cps.
- ✓ Pickup tracking — the most sensitive tests ever available to the amateur for checking cartridge, stylus, and tone arm.
- ✓ Hum and rumble — foolproof tests that help you evaluate the actual audible levels of rumble and hum in your system.
- ✓ Flutter — a test to check whether your turntable's flutter is low, moderate, or high.
- ✓ Channel balance — two white-noise signals that allow you to match your system's stereo channels for level and tonal characteristics.
- ✓ Separation — an ingenious means of checking the stereo separation at seven different parts of the musical spectrum — from mid-bass to high treble.

ALSO: ✓

Stereo Spread  
Speaker Phasing  
Channel Identification

## PLUS SUPER FIDELITY MUSIC!

The non-test side of this record consists of music recorded directly on the master disc, without going through the usual tape process. It's a superb demonstration of flawless recording technique. A demonstration that will amaze and entertain you and your friends.

# NOW...GET THE FINEST STEREO TEST RECORD ever produced

for just...**\$4.98**

## Featuring Tests Never Before Available To The Hobbyist

### UNIQUE FEATURES OF HiFi/STEREO REVIEW'S MODEL 211 STEREO TEST RECORD

- Warble tones to minimize the distorting effects of room acoustics when making frequency-response checks.
- White-noise signals to allow the stereo channels to be matched in level and in tonal characteristics.
- Four specially designed tests to check distortion in stereo cartridges.
- Open-air recording of moving snare drums to minimize reverberation when checking stereo spread.

## All Tests Can Be Made By Ear

HiFi/STEREO REVIEW's Model 211 Stereo Test Record will give you immediate answers to all of the questions you have about your stereo system. It's the most complete test record of its kind—contains the widest range of check-points ever included on one test disc! And you need no expensive test equipment. All checks can be made by ear!

*Note to professionals: The Model 211 can be used as a highly efficient design and measurement tool. Recorded levels, frequencies, etc. have been controlled to very close tolerances — affording accurate numerical evaluation when used with test instruments.*

## DON'T MISS OUT—ORDER NOW

The Model 211 Stereo Test Record is a disc that has set the new standard for stereo test recording. There is an overwhelming demand for this record and orders will be filled by POPULAR ELECTRONICS promptly upon receipt. At the low price of \$4.98, this is a value you won't want to miss. Make sure you fill in and mail the coupon together with your check (\$4.98 per record) today.

### FILL IN AND MAIL TODAY!

Stereo Test Record N  
Popular Electronics—Dept. SD  
One Park Ave., New York 16, N.Y.

Please send me \_\_\_\_\_ test records at \$4.98 each. My check (or money order) for \$ \_\_\_\_\_ is enclosed. I understand that you will pay the postage. (Orders from outside the U.S.A. add 50c to partially defray postage and handling costs.)

Name \_\_\_\_\_  
(Please Print)

Address \_\_\_\_\_

City \_\_\_\_\_ Zone \_\_\_\_\_ State \_\_\_\_\_

Sorry—No charges or C.O.D. orders!

EEH-65

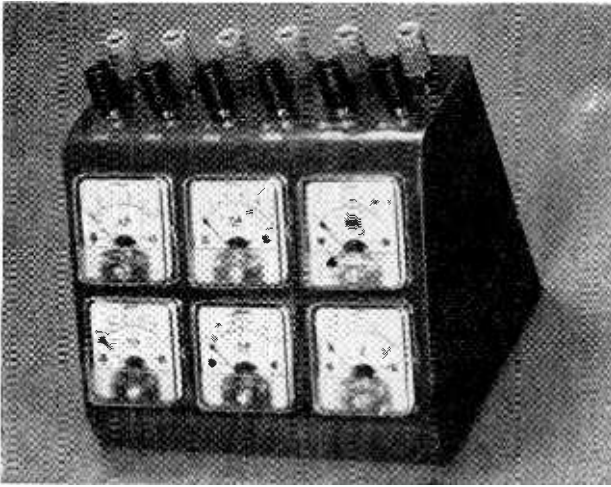

# MULTIPLE METER TEST SET

“CONNECT A VOLTMETER across the power supply and prepare to meter the input to the amplifier. Adjust the value of the  $Q2$  bias resistor for a base to emitter voltage of  $-0.1$  volt, making sure that the collector current does not exceed 12 ma.” At about this point, you curse the writer of the instructions as a bloated plutocrat—he and all his test equipment vs. your lonely VOM.

Anyone who constructs electronics equipment as a hobby is well aware of the measurement problems involved. Voltage readings are not too difficult to take, but measurement of current at a number of points in the circuit is a different matter. Invariably the circuit must be opened, a meter inserted, a reading taken, the circuit closed up and the meter moved to the next point.

The compact little instrument shown here is a convenient answer to the problem of how to make several simultaneous measurements. Its cost is surprisingly low since use is made of imported meters—the author obtained his from Lafayette Radio via mail order. Besides a 0-15 volt d.c. meter, the cabinet holds one 0-50  $\mu$ a. (d.c.), one 0-1 ma., one 0-5 ma., one 0-50 ma., and one 0-100 ma. meter. The cabinet is a Premier ASPC-1202 with a sloping front.

—Roy E. Pafenberg

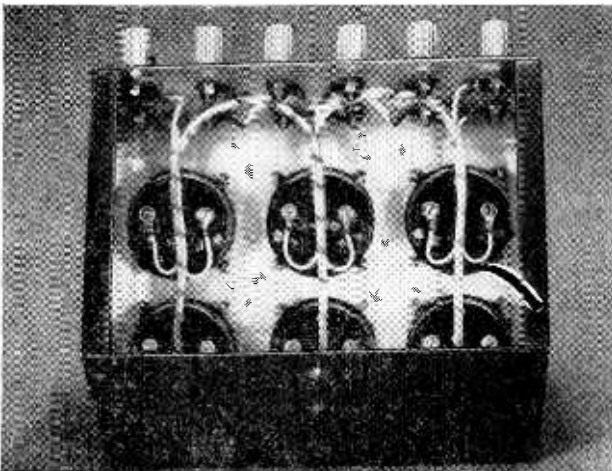

Mount the six meters in a logical pattern so that the scales increase from left to right and top to bottom. Bring the meter leads out to insulated terminals or binding posts on the top ledge of the cabinet. Use color-coded terminals so that red indicates the plus meter lead and black the minus lead.

# MULTI-OUTPUT ZENER VOLTAGE REGULATOR

By HAROLD REED

**T**HIS simple voltage regulator will provide regulated outputs at most commonly used values for semiconductor circuits—nominally 3, 6, 9 and 15 volts. By using a special switching arrangement, only two low-cost zener diodes and three resistors are required. Any suitable d.c. source adjusted to 17 volts can be used for the input.

If a d.c. supply is not on hand, the constructor can build an a.c. rectifier especially for the regulator. Good regulation is obtained even with a simple half-wave diode supply.

**How It Works.** The schematic shows that the two zener diodes (*D1* and *D2*, 6.2- and 9.1-volt units respectively) are switched into four different circuit configurations.

With the switch in the first position, both diodes are used. The regulated output is the difference potential of the diodes, which is 2.9 volts. The second switch step provides a 6.2-volt regulated output. Here, only *D1* is used. On the third switch step, only *D2* is used and a 9.1-volt regulated output is available. In the fourth position, the two diodes are connected in series, giving a 15.3-volt regulated output.

The zener diodes are rated at 400 milliwatts. These diodes are also available with ratings from 250 milliwatts up to 10 watts at various voltages. Thus, a regulator of this type can be constructed to handle considerably larger currents and with many different combinations of regulated outputs.

The device is housed in a 4" x 2¼" x 2¼" aluminum box with identifying decals on the front panel. Parts placement and internal wiring are not critical. If a slightly larger box is used, a completely self-contained unit can be made by incorporating a power supply using germanium or silicon diodes.

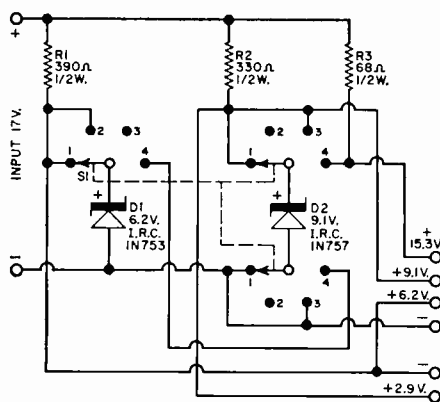
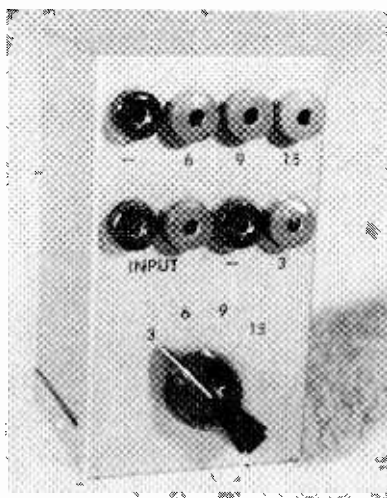

Multiple outputs are available from this small regulator. Note that the 2.9-volt circuit has a separate negative terminal.

**Testing the Unit.** The regulator was tested with one of the simplest types of power supplies consisting of a half-wave rectifier and a capacitor-resistor filter.

With a regulated output of 6.2 volts, starting with zero load current, the output remained steady as the load current was increased. When the load current reached 24 ma., the output dropped 0.3 volt. The 9.1-volt output held steady from zero load current up to 20 ma., when it also went down only 0.3 volt. Output from the 15.3-volt terminal dropped 0.5 volt between zero and 22 ma. load current. Likewise, the 2.9-volt output held steady and went down only 0.2 volt when the load current reached 10 ma.

In these tests, zero load current represented no load at all connected across the output terminals.

-30-



# The Best of

# TIPS & TECHNIQUES

## TETRACHLORIDE TAPPING TIP

If you use oil as a lubricant when tapping holes in metal, you may find that after a short time the oil gums, binds the tap, and the tap breaks off. To prevent this sort of tragedy, try using carbon tetrachloride as a tap lubricant. Because of its high rate of evaporation, neither gumming nor binding will occur, and you'll have a cleaner job. The carbon tet

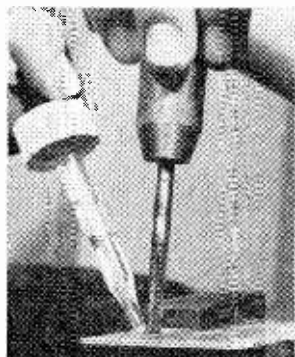

can be stored in an old medicine dropper bottle which will also serve as a convenient

dispenser. However, make sure that the room is well-ventilated while you're using the carbon tet.

—Robert K. Dye

## CLOCK RADIO SERVES AS TV TIMER

A few slight modifications to your clock radio will enable it to turn your TV set on automatically at a definite time. Add an outlet to your radio and wire it according

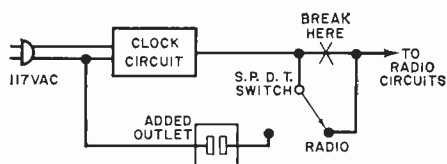

to the diagram. The s.p.d.t. switch can be mounted near the outlet. Locate the wire from the clock switch to the radio circuits and wire the added components as shown. When the TV set is plugged into the new



# FREE! HOW TO IMPROVE YOUR TWO-WAY RADIO!

The right communications microphone may double the talk power of even the finest transmitters! Learn how unwanted noise can be eliminated—reliability improved—intelligibility increased by proper microphone selection.

Write for our helpful free booklet today!

ELECTRO-VOICE, INC., Dept. 1052EH  
Buchanan, Michigan 49107

Please send the free E-V booklet on choosing communications microphones. I am interested in the following areas of two-way radio:  Amateur  Aviation  CB  Business.

NAME \_\_\_\_\_

COMPANY \_\_\_\_\_

ADDRESS \_\_\_\_\_

CITY \_\_\_\_\_ STATE \_\_\_\_\_

**Electro-Voice**

SETTING NEW STANDARDS IN SOUND

CIRCLE NO. 7 ON READER SERVICE CARD

# SELLING YOUR TRANSCEIVER? BUYING THAT AMPLIFIER?

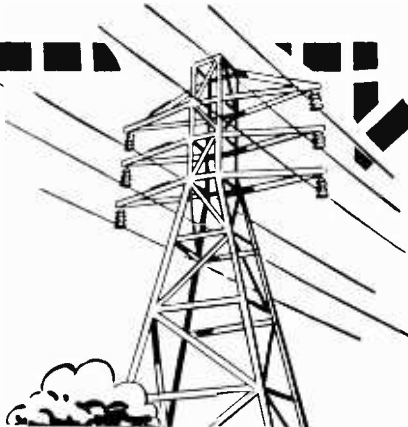

The 400,000 Live Wires who buy POPULAR ELECTRONICS each month will make it worth your while to place a classified ad at the low personal rate of only 55¢ a word.

This, the largest readership in its field in the world, offers the perfect market for making contacts. It's possible a great many of these readers are practically neighbors of yours, yet it is only through the medium of our classified columns that your mutual needs may be met.

Take advantage of our special personal rate of 55¢ a word (including name and address)

## NO MINIMUM REQUIRED

a saving of 35¢ a word from our commercial rate of 90¢.

A small investment is sure to bring large results. Write your ad today and mail it with your payment, to:

Hal Cymes  
Classified Advertising Manager  
POPULAR ELECTRONICS  
One Park Ave., New York, N. Y. 10016

JANUARY ISSUE CLOSURES NOV. 1ST

outlet, it will be controlled by the clock mechanism if the switch is in the TV position. If the clock radio is equipped with a "sleep switch," you can use this to shut the set off automatically.

—Fred Blechman, K6UGT

## SUBSTITUTING RECTIFIER TUBES

Be wary about replacing a rectifier tube such as a 5U4 with a 5DJ4 or similar tube. While at first glance the tube pin numbers and specifications may seem similar, many manufacturers utilize unused socket terminals as convenient tie points for components

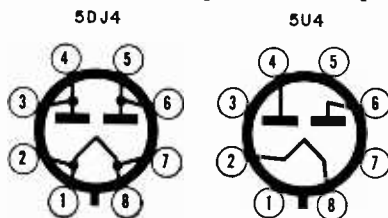

PINS 1, 3, 5, AND 7  
MAY BE USED AS  
TIE POINTS

that may not even be a part of the rectifier circuit. The 5DJ4 has internal connections to tube pins that are not normally used in the 5U4. For example, if your set has a 5U4 rectifier socket with pin 5 as a ground, you'll have real trouble substituting a 5DJ4!

—Carleton A. Phillips

## NEAT LAYOUT FOR PRINTED-CIRCUIT BOARDS

You'll find it easier to keep components on a printed-circuit board aligned and neatly arranged if you try this simple tip. Instead of laying out the board with penciled guide

lines (they tend to erase themselves while you work), place a piece of perforated board over the copper laminated board, and spray with acrylic paint from a height of at least two feet. This will give you a grid of small dots on the circuit board to use as component centers and guides for the copper runs. After laying out the resist tapes, quickly slosh the board with lacquer thinner to remove the paint; if

you work fast, the tapes will not be affected. If you use the resistive ink method, the dots can be removed with an ordinary ink eraser.

—Donald E. Lancaster

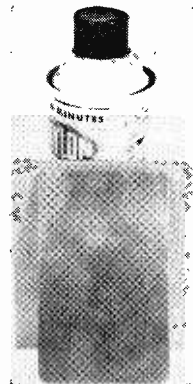

## HANDY HOLDER FOR HARDWARE

If you attach a large and small rubber suction cup back to back, the result is a handy stick-on hardware holder. Fill the hole in the larger cup with epoxy cement, and insert the screw lug of the smaller. The hardwareholder can then be attached to TV cabinets, tool box lids or other supports, and used for small parts, nuts, bolts or washers.

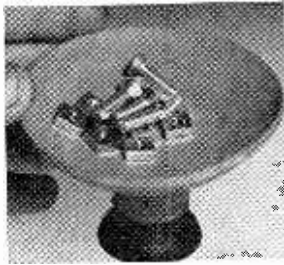

—John A. Comstock

## STORING ADAPTER SOCKETS

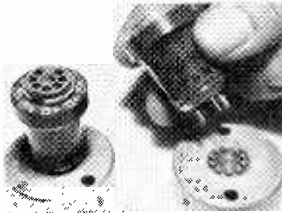

To keep your adapter sockets handy and safe, there's no better place to put them than in your tube pin straighteners. The adapter socket pins

will be protected, and the sockets themselves will be ready for use at all times.

—Clyde C. Cook

## CAP AEROSOL "WILDCATS" TO AVOID MESSY ACCIDENTS

Don't discard the protective cap on the next can of aerosol tuner cleaner you buy—it can keep the contents of the can from being accidentally released, particularly when the can is carried from job to job. As slipping the cover on and off and attaching and detaching the extender for each job would be a nuisance, you can neatly trim out the top of the plastic cover with a small knife. Then drill or punch a hole on the side of the cap for the spray extender tube. When the can is empty, the modified cap can be transferred to a new can.

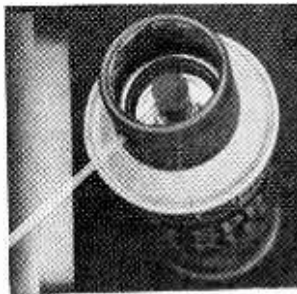

—Elmer C. Carlson

You've got to SEE it to BELIEVE it!

# instant lettering<sup>®</sup> dry transfer MARKING KITS for ELECTRONIC EQUIPMENT

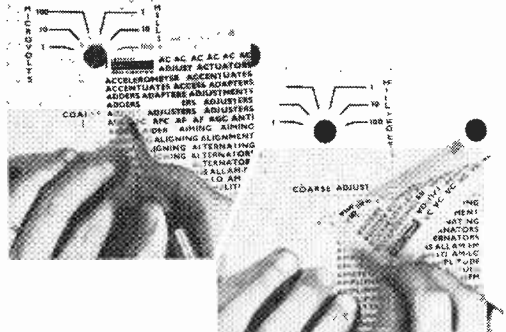

"Instant Lettering" marking kits bring you all the necessary elements for completely marking electronic equipment, drawings, prototypes, schematics, etc. in a fast new easy-to-use form.

Words, letters, numerals, switch patterns, arcs, etc. are printed on a special transparent carrier film. Rubbing over one of these elements with a ballpoint pen releases it from the carrier film and adheres it to your working surface.

"Instant Lettering" words and patterns transfer to almost any surface including glass, plastic, metal... even crackled finished metal. Now you can quickly mark all panels, even especially calibrated two-color meter dials, tap switches, panel nomenclatures, pilot light jewels, sub-assemblies, circuit boards, etc. Reproduction quality "Instant Lettering" transfers are clean and sharp, leave no background haze or film, make prototypes look like finished production equipment and give all equipment and drawings a professional look.

## TITLES FOR ELECTRONIC EQUIPMENT

This set contains hundreds of preprinted titles researched to give you up to 95% of all electronic marking. For labeling, marking, titling all electronic control panels, drawings, prototypes, etc.

No. 958 — BLACK.....\$4.95 No. 959 — WHITE.....\$4.95

## TERMINAL & CHASSIS MARKING KIT

Contains all the necessary letters, letter combinations and numerals for marking chassis, printed circuit and terminal boards, rotating components, etc.

No. 966 — BLACK.....\$4.95 No. 967 — WHITE.....\$4.95

## METER & DIAL MARKING KIT

Arcs, dial patterns, lines, wedges, graduation lines, switch symbols, alphabets and numerals in black, white and red for marking standard and special rotary tap switches, potentiometers and prototype and especially calibrated meter dials. Colors provide contrast on scales and switches simplifying usage of complex instruments.

No. 968 — METER & DIAL MARKING KIT.....\$4.95

WRITE FOR FREE SAMPLE AND COMPLETE DETAILS

# THE DATAK CORPORATION

63 - 71st St. • Dept. 634 • Guttenberg, N. J.  
CIRCLE NO. 4 ON READER SERVICE CARD



# If you missed it...

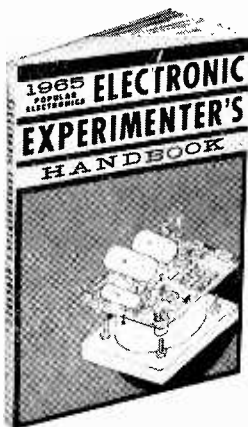

THE  
SPRING  
1965  
EDITION  
OF  
**ELECTRONIC  
EXPERIMENTER'S  
HANDBOOK**

# SEND FOR IT RIGHT NOW!

**ALSO AVAILABLE:**  
Limited Quantities of the  
1962, 1963 and 1964 editions —  
priced at just \$1.00 each!

ZIFF-DAVIS SERVICE DIVISION • Dept. EEH  
589 Broadway, New York, N. Y. 10012

**YES!** I want to receive copies of the editions of  
ELECTRONIC EXPERIMENTER'S HANDBOOKS  
checked below:

- Spring 1965 — \$1.25\*  
 1964     1963     1962    ← \$1 EACH\*

\*add 15c per copy for postage and handling. Add 25c per  
copy outside U.S.A.

name \_\_\_\_\_ please print  
 address \_\_\_\_\_ EEH-65  
 city \_\_\_\_\_ state \_\_\_\_\_ zip code \_\_\_\_\_

---PAYMENT MUST BE ENCLOSED WITH ORDER.---

## "FILM" STORAGE FOR SMALL PARTS

Small parts, such as resistors, capacitors and diodes, often become tangled and hard to locate when they are stored haphazardly in boxes. An easy way to keep them in order is to slip their leads through the perforations of 35-mm. film strips as shown. The film strips, together with the components, can then be neatly filed or tacked to a convenient shelf for easy access.

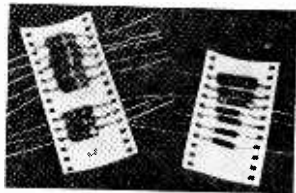

—Art Blaske

## SNAP-TYPE CLOTHESPIN MAKES BANANA PLUG ADAPTER

There's probably a bunch of banana-plug-to-pin-jack adapters in your home—in the family clothespin bag. To make an adapter, take the spring off a snap-type clothespin and cut the arms of the spring as shown here. The straight end of the spring can

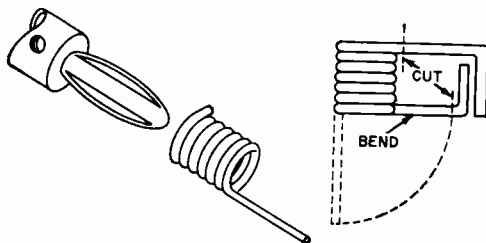

be soldered to a printed-circuit board, giving you a banana jack, or you can insert the end in a pin jack and use leads terminated in banana plugs.

—R. D. Holen

## QUICK SERIES CONNECTION OF DRY CELLS FOR EXPERIMENTS

When you need some multiple of 9 volts d.c. for an experimental hookup, the quickest

way to get it is to plug two or more 9-volt transistor batteries together, as shown. Make the output connection to the two terminals left exposed on the directly connected dry cell bank. Incidentally,

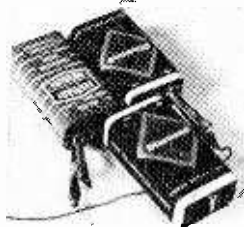

you can use connectors taken from discarded cells for the wire ends to make connection and disconnection easy.

—Patrick Snyder

## DEGAUSS YOUR TAPE RECORDER HEADS

When your tape recorder begins to sound "muddy," it's a good indication that the heads are in need of degaussing (or demagnetizing). There are commercial degaussers available, but it's easy to make one. Saw a  $\frac{1}{8}$ " slot in a  $\frac{1}{2}$ " flat iron washer and wind six or eight turns of #14 or #16 insulated wire on the washer. Connect the wire ends to your soldering gun (after you remove the soldering element), and you'll be able to degauss both the heads and guides. The tool can also be used to erase small sections of recorded tapes, such as unwanted switch pops, or words.

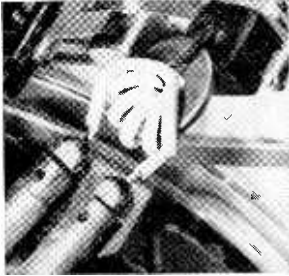

—R. K. Dye

## RUBBER FEET FROM SUCTION CUPS

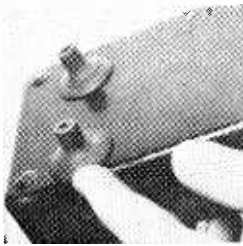

You can make some dandy rubber feet for your instruments from simple suction cups. Rubber cement will hold them in place, or, if you like, a small hole can be drilled in each suction cup and a bolt

used to attach it to the cabinet. The suction cups are resilient and provide good shock protection.

—John A. Comstock

## LIGHT FLASHER MAKES LOW-HEAT SOLDERING GUN

Ever need a particularly low heat for soldering miniature or transistor circuits? If you connect your soldering gun through an ordinary Christmas tree light flasher, it will cycle the gun on and off, keeping the heat at a low but usable level. You can get a 100-watt flasher from your local hardware or electrical appliance store. Just plug the flasher unit into the bench outlet, and the soldering gun into the flasher.

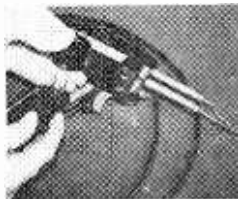

—John Lias Wilson

## Get Your First Class Commercial F.C.C. LICENSE and earn your A.S.E.E. DEGREE

Grantham School of Electronics can prepare you quickly for a career in electronics. In 4 months you can prepare for employment as a communications technician, or in 8 months as a television technician, or in 18 months as a highly-trained electronics technician holding an *Associate in Science in Electronics Engineering* Degree.

The Grantham degree curriculum is laid out in such a manner that the *first semester* (first 4 months) prepares you for a first class FCC license and for technical employment in communications, and that the *first two semesters* prepare you for employment as a television technician in a TV-service shop or in a TV-broadcast station. Therefore, you may choose to discontinue Grantham training at the end of either the first or second semester *and still* enjoy a productive career in electronics. Also, if you wish to continue and earn the degree, your ability to work in electronics after the first semester may enable you to "pay your way" through the rest of the course.

Those who continue for the degree must take the final two semesters at the Hollywood Division of the School. These final semesters include a lot of applied math, as well as some physics, technical drawing, English, etc.

Daytime or evening class schedules are available. Also, FCC license preparation is available by correspondence. Get complete details by telephoning or writing any one of the Divisions of the School listed below. Ask for *Catalog 5X*.

### Grantham School of Electronics

1505 N. Western Av., Hollywood, Cal. 90027  
(Phone: HO 9-7878)

408 Marion Street, Seattle, Wash. 98104  
(Phone: MA 2-7227)

3123 Gillham Road, Kansas City, Mo. 64109  
(Phone: JE 1-6320)

818-18th St., NW, Washington, D.C. 20006  
(Phone: 298-7460)

## GIANT CB SALE!!

Hallmark Transceiver (Model 1250)	SALE \$99.99
Midland Walkie Talkie (Model 13-105)	EACH \$13.50
SPECIAL SALE	
Ross Walkie Talkie (11 transistor)	2 for \$25.88
Ross 6 Transistor AM RADIO	SALE \$29.95
2 Station Transistor INTERCOM	SALE \$ 3.99
	PAIR \$ 7.99

### BUILDER'S SPECIALS

Capacitor Substitution Box (600 WVDC)	SALE \$ 2.39
Resistor Substitution Box	SALE \$ 3.59
Test Oscillator—transistorized (Sig Gen)	SALE \$16.95
Volume Controls (10 ass'td)	SALE 99¢
Timing Motors—110V (5 ass'td)	SALE \$ 1.99
Solder Gun—100W with spotlight	SALE \$ 2.49

### TERRIFIC SALE PRICES ON HY-GAIN CB TOPPER ANTENNAS!

TLWR Roof mount Omni-Topper (reg \$11.97)	SPECIAL \$ 9.88
TTMP AM-CB Duo-Topper (reg \$14.95)	SPECIAL \$12.19
TLWT Telescoping Topper Whip (reg \$7.20)	SPECIAL \$ 5.88
TLWM 50" Topper + Chr. Body Mount (reg \$8.95)	SPECIAL \$ 7.20
TRC Roof mount Omni-Topper (reg \$14.95)	SPECIAL \$12.15
TMC All purp. Topper + Body Mount (reg \$12.95)	SPECIAL \$ 5.40
TLW 50" Top-loaded Whip (reg \$6.96)	SPECIAL \$10.50
CB-3 3 element Beam Antenna (reg \$19.95)	SPECIAL \$17.95

Command CB Crystals (.002%)	EACH \$ 1.79
(Specify Make, Model Channel), 12 or more at EACH	\$ 1.69
FS-60 SWR Bridge & Field Str. Meter	SALE \$ 9.89
SN-3 Mobile Noise Suppressor Kit (15 pc)	SALE \$ 4.99
Headset with Mike for CB	SALE \$ 4.88
Trumpet Horn Speaker (5" round—paging)	SALE \$ 7.49

### SEND FOR GROVE BARGAIN FLYER—MAILED FREE!

Send check or money order, include postage, excess refunded. Minimum order \$5.00—50¢ service charge under \$10.00. 50% deposit on COD's.

### GROVE ELECTRONIC SUPPLY COMPANY

4107 W. Belmont Ave. Chicago, Ill. 60641

CIRCLE NO. 9 ON READER SERVICE CARD

# FREE GIANT NEW CATALOG

100's OF BARGAINS NOT IN ANY OTHER CATALOGS

TOP VALUES IN POWER & HAND TOOLS

SAVE UP TO 50% ON CAMERA FILM & PHOTO EQUIPMENT!

100's JOURNAL CATALOG

RADIO-TV-ELECTRONICS

100's OF BIG PAGES CRAMMED WITH SAVINGS

THIRD PARTS ETC AT LOWEST PRICES

EVERYTHING IN HI-FI AND STEREO

## BURSTEIN-APPLEBEE CO.

Dept. EX, 1012 McGee, Kansas City, Mo. 64106

Rush me FREE 1966 B-A Catalog.

Name .....

Address .....

City ..... State .....

Please be sure to show your Zip No. ....

SEND FOR IT TODAY

FREE

CIRCLE NO. 3 ON READER SERVICE CARD

## CAMERA TRIPOD PINCH-HITS AS MIKE STAND



A floor stand for a microphone is not often listed as standard equipment for a home tape recordist. For easy recording of noise-free tapes, however, it is almost a necessity. If you own a camera tripod, you can attach your microphone to the tri-

pod's swivel head with a simple clamp or bracket, and derive all the benefits of a good mike stand.

—Glen F. Stillwell

## EASY WAY TO MOUNT PHONO JACK ON P-C BOARD

Here's how to mount a phono jack at right angles to a printed circuit board with a minimum of fuss. You'll need a crimp-on closed-eye-terminal for a ¼" stud and a Cinch-Jones Y-142 adapter (available for about three cents from any distributor). Cut the terminal just at the ferrule so you have a ⅛" tab projecting from the original eye. Flatten the Y adapter.



Now mount the terminal and adapter near the edge of the board facing each other and about ⅞" apart. Insert the phono jack, tighten the nut, and solder the connections. The resulting mount is compact, neat, and rugged.

—Don Lancaster

## PLASTIC CASES HOLD METERS OR SPEAKERS

Discarded plastic TV booster or antenna rotor control cases of the type shown in the photo make excellent mounts for meters or for a miniature speaker. Strip the parts and chassis from the case, and, if you're lucky, the meter or speaker will fit in the hole left by the dial without further modifications. If necessary, enlarge the mounting hole

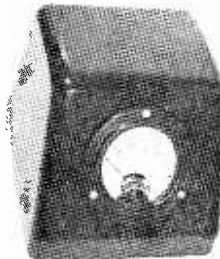

with a hacksaw blade, and drill holes for mounting screws around the perimeter.

—Carleton A. Phillips

## SCR Tester

(Continued from page 124)

Thus, lighting of the "Forward" lamp as soon as the SCR is connected into the circuit indicates failure of the forward blocking junction. Lighting of the "Reverse" lamp at any time indicates breakdown of the reverse blocking junction. If neither lamp lights when the SCR is connected into the circuit, the "Test" push button is operated, applying a source voltage to the gate.

The "Forward" lamp should light under these circumstances if the SCR is good. If this lamp does not light when the button is depressed, the gate is either open or shorted.

This tester applies about 35 peak volts to the SCR anode so that higher voltage capabilities of the unit are not indicated. With very small SCR's, heat sinking may be necessary.

The device can also be used to test ordinary rectifiers by connecting them

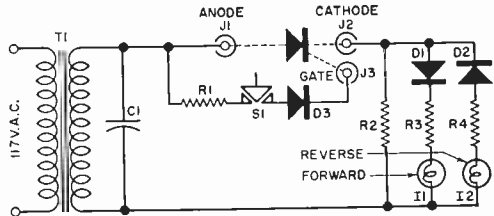

### PARTS LIST

- C1—0.05- $\mu$ f., 200-volt capacitor
- D1, D2, D3—100-volt, 1.6-amp. silicon rectifier (1N1218)
- I1—#47 indicator lamp (Dialco 81410-112—green—or equivalent)
- I2—#47 indicator lamp (Dialco 81410-111—red—or equivalent)
- J1, J2, J3—Binding post (Johnson 111-101, 111-102, 111-103, or equivalent)
- R1—100-ohm, 1-watt resistor
- R2—50-ohm, 10-watt resistor
- R3, R4,—75-ohm, 5-watt resistor
- S1—Normally open push-button switch
- T1—Filament transformer, 25.2 volts @ 1 amp. secondary (Stancor P-6469 or equivalent)

across the "Anode" and "Cathode" terminal posts. With the rectifier properly connected, a good one will light the "Forward" indicator lamp, an open one will keep both lamps off, and a shorted one will make both lamps come on. —30—

# YOUR NEW COPY IS WAITING



**FREE!** For fun and pride in assembly, for long years of pleasure and performance, for new adventures in creative electronics mail the coupon below and get Conar's brand new catalog of quality do-it-yourself and assembled kits and equipment. Read about items from TV set kits to transistor radios . . . from VTVM's to scopes . . . from tube testers to tools. And every item in the Conar catalog is backed by a no-nonsense, no-loopholes, money-back guarantee! See for yourself why Conar, a division of National Radio Institute, is about the fastest growing entry in the quality kit and equipment business.

# CONAR

**MAIL THIS COUPON NOW**

CONAR

KQ5C

3939 Wisconsin Ave., Washington 16, D.C.

Please send me your new catalog.

Name \_\_\_\_\_

Address \_\_\_\_\_

City \_\_\_\_\_ State \_\_\_\_\_ Z-Code \_\_\_\_\_

CIRCLE NO. 19 ON READER SERVICE CARD

## Transistor Voltmeter

(Continued from page 129)

voltmeter is largely determined by the input resistor string, resistors  $R2$  through  $R9$  should be stable and preferably have an accuracy of  $\pm 1.0\%$ . Of course, if you have access to a bridge, standard  $\pm 5\%$  resistors can be measured and very close values selected on this basis.

Resistor  $R13$  must be selected so that potentiometer  $R14$  will adjust near its center position to set meter  $M1$  to a zero deflection. The value of  $R13$  may vary from 1000 to 5000 ohms, but once set it will need no further adjustment.

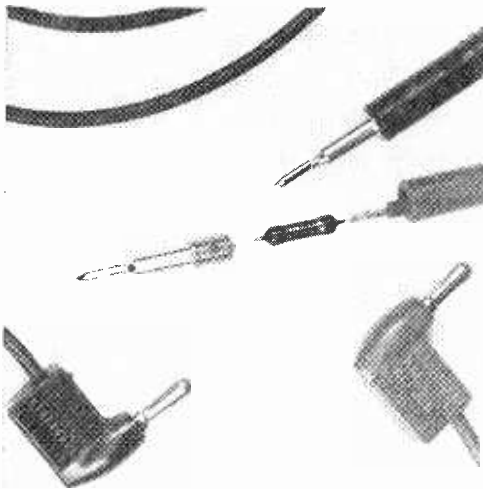

Solder resistor  $R1$  to pin of probe and slip it inside red handle. Probes need not be reversed to reverse polarity; this is accomplished through  $S2$ .

**Construction and Calibration.** The voltmeter can be built on a single piece of phenolic board and attached to the back of meter  $M1$  through the meter input terminals. Except for the resistor in the probe, all of the resistors can be mounted to the board with Vector terminals and soldered in place. The layout should approximate that in the photo to eliminate the possibility of leakage paths in the input part of the circuit.

The final accuracy of the voltmeter depends on the values of resistors  $R2$  through  $R9$  as well as a calibrating voltage source. Ideally, a digital voltmeter of known accuracy and a variable d.c. voltage source should be used. However, initial calibration with several 1.34-volt mercury batteries may be used to set the 0-5 volt scale. Full-scale sensitivity is adjusted by varying potentiometer  $R12$  and locking it into position once satisfactory calibration has been established.

-50-



JACK SCHMIDT

"One at a time, Mister!"

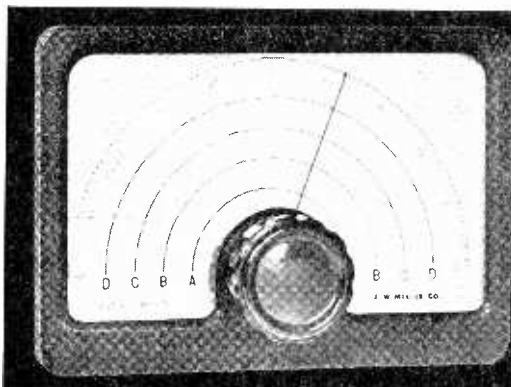

### VERNIER DIALS—9 to 1 and Combination 36 to 1 & 6 to 1

MODEL NUMBER	TURNS RATIO	NO. OF SCALES	NET PRICE
MD-5	9 to 1	4	\$ 8.25
MD-6	9 to 1	6	\$ 9.00
MD-7*	36 to 1 & 6 to 1	6	\$15.00
MD-8*	36 to 1 & 6 to 1	6	\$15.00

\*Dial allows fast tuning at a 6 to 1 ratio with fine tuning at the 36 to 1 ratio over any 6-division portion of the scale.

**J. W. MILLER COMPANY**

5917 So. Main Street • Los Angeles, California 90003

## Resonance Engine

(Continued from page 92)

90). Although the weight of the flywheel should not be too critical, some experimenting may be in order. The author's was made of aluminum and weighed about 15 ounces. Drill and tap one end of the flywheel shaft for a 6-32 machine screw and thread the opposite end with a  $\frac{1}{4}$ "-20 die.

The flywheel shaft bearing—a  $1\frac{1}{2}$ " brass rod  $\frac{1}{8}$ " in diameter with a  $\frac{1}{4}$ " hole drilled through the center—is mounted in the bracket shown in Fig. 7 and in the assembly drawing. The bracket is made with a stiffening buttress so that it will stand up under the vibration of the engine. In the author's unit, the bracket was mounted to the coil platform by tapping three small pieces of brass rod and cementing them into holes drilled into the bottom of the bracket. Wing bolts thread into the holes from the bottom of the coil platform, making it easy to disassemble the engine for other experiments. In any case, drill a  $\frac{1}{2}$ " hole in the bracket at the height shown in Fig. 7, and cement the bearing in it with epoxy glue.

**Mounting Stand.** Make a double-deck stand as shown in the photos and secure the capacitors, *C1*, *C2*, *C3*, to the lower section. Mount the d.p.d.t. toggle switch, *S1*, and four pin jacks, *J1*, *J2*, *J3*, *J4*, on the upper deck of the stand in front of the coil position. Drill holes in the upper deck for coil leads, coil mounting screws, bracket mounting screws, and for the engine piston. The piston hole should be large enough to provide ample clearance.

Mount all of the parts on the stand as shown in the assembly view on page 92. Solder the end of the flywheel shaft to the end of the crankshaft where the two join together. To hold the long 12" core in place for repulsion coil experiments, drill and tap the top disc for a setscrew that extends from the outer rim into the center hole.

Connect the parts as shown in the schematic diagram on page 92. You will note that the diagram shows a "discharge" position for *S1*. This is a safety

## Thinking of college and a space age career in electronics?

How to prepare for  
**YOUR CAREER**  
in Engineering Technology and Engineering

**M SO E**  
MILWAUKEE SCHOOL OF ENGINEERING  
BULLETIN

### Send for this booklet on ENGINEERING TECHNOLOGY AND ENGINEERING

Learn how you can prepare for a dynamic career as an electrical or mechanical engineering technician or engineer in such exciting, growing fields as avionics, missiles, reliability control, fluid mechanics, data processing, metallurgy, microelectronics, and advanced aerospace research.

MSOE offers residence study programs leading to these degrees in engineering technology and engineering:

2 years — Associate in Applied Science

4 years — Bachelor of Science

Also get facts about scholarships and financial aids, job placement and other student services, plus photographs of MSOE technical laboratories and student activities. For your copy, just mail the coupon — no obligation.

# M SO E

Milwaukee School of Engineering

Milwaukee School of Engineering  
Dept. EXH-865, 1025 N. Milwaukee Street  
Milwaukee, Wisconsin 53201

Please send the "Your Career" booklet.  
I'm interested in

Electrical fields       Mechanical fields

Name..... Age.....

Address.....

City..... State..... ZIP.....

MS-227

CIRCLE NO. 17 ON READER SERVICE CARD

## New from TECHPRESS



**Radar—Principles and Practices** is a basic study of land, marine, and airborne radar. Includes fundamentals of transmitters, receivers, antennas, synchros and servos. Discusses radar systems, test equipment, all types of oscillators, amplifiers, waveguides, and hardware used in radar. An ideal introduction to small and large craft radar. An absolute must for broadening your horizons! 6" x 9" 280 pages Cat. No. 01-RP.....only \$4.95

**Receiving Tube Specifications and Substitutions** contains over 2,000 American and foreign tubes listed both according to type and characteristic. Lists entertainment, industrial, and military tubes. Specs include all cathode and plate voltages and currents, cathode type, gain, capacitances, etc. Includes substitutes listing, basing information, etc. 6" x 9" 140 pages Cat. No. 01-VT.....only \$1.95

**Transistor Specifications and Substitution Handbook** lists over 5,000 American and foreign types, and over 16,000 subs. Specs comprise: P<sub>c</sub>, I<sub>c</sub>, V<sub>ce</sub>, V<sub>cb</sub>, V<sub>eb</sub>, h<sub>fe</sub>, I<sub>cb</sub>, F<sub>t</sub>, type and use. Base diagrams and other valuable information included. 6" x 9" 128 pages Cat. No. 01-SSH-2.....only \$1.95

**Diode Select-A-Spec** is a compilation of the specs and substitutes for both signal and power diodes. Specs include: V<sub>w</sub>, P<sub>RV</sub>, I<sub>f</sub>, V<sub>f</sub>, and I<sub>r</sub>. Over 20,000 American and foreign substitutes listed. 6" x 9" 138 pages Cat. No. 01-DS.....only \$2.95

**Selected Semiconductor Circuits** contains simple, easy-to-build circuits on power supplies, converters, RF and AF amplifiers and oscillators. Many others. 6" x 9" 80 pages Cat. No. 01-SC.....only \$1.25

**TechPress Publications**  
Brownsburg, Indiana, 46112

CIRCLE NO. 29 ON READER SERVICE CARD

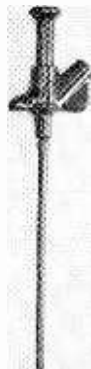
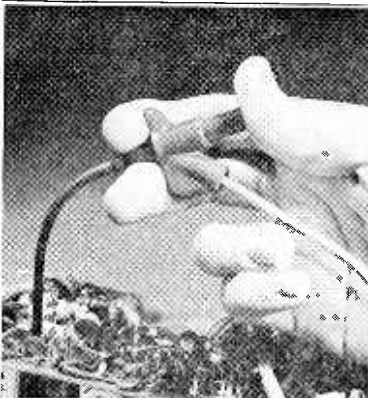

## Clever Kleps 30

Push the plunger. A spring-steel forked tongue spreads out. Like this  Hang it onto a wire or terminal, let go the plunger, and Kleps 30 holds tight. Bend it, pull it, let it carry dc, sine waves, pulses to 5,000 volts peak. Not a chance of a short. The other end takes a banana plug or a bare wire test lead. Slip on a bit of shield braid to make a shielded probe. What more could you want in a test probe?

Available through your local distributor, or write to: **\$147**

**rye**  
SOUND

RYE SOUND CORPORATION  
130 Spencer Place, Mamaroneck, N.Y.

CIRCLE NO. 25 ON READER SERVICE CARD

device to discharge the capacitors after the unit has been in use. Label S1's positions (S1 is a center-off type) "On," "Off," and "Discharge."

**Testing the Engine.** When the assembly and wiring are done, spin the flywheel by hand to make certain there is no undue friction. Use light oil on all bearings and piston surface. With everything ready to go, plug the unit in, turn the switch on, and give the flywheel a turn in either direction. The flywheel will pick up speed and be on its way. Like most single-cylinder reciprocating engines, your engine will require an initial start, unless the crank is turned to its upper position, slightly off center.

**Theory.** How does the resonant engine operate? One of the laws governing a series-resonant circuit is that when the reactance of the capacitor equals the reactance of the coil, the maximum amount of current will flow in the circuit. The reactance of the capacitors is fixed; the reactance of the coil depends on the piston core's position.

When the piston core is slightly above its lowest point of travel, or the same distance below its upper point of travel, the reactance of the coil equals that of the capacitor, and the circuit is resonant. In operation, the piston is drawn toward one of the resonant positions, but the flywheel carries it beyond that point and the circuit drops sharply out of resonance. From there on, the piston is carried by the momentum of the flywheel to the next resonant position.

The value of the capacitance needed for the resonant engine is 10.6  $\mu\text{f}$ . As shown in the schematic, the author got this value by connecting 1- and 2- $\mu\text{f}$ . units in series, and then connecting them in parallel with a 10- $\mu\text{f}$ . unit. Other combinations can, of course, be used to arrive at 10.6  $\mu\text{f}$ .

**Other Experiments.** Want to make a step-down transformer? Wind a 40-turn coil of wire and connect it to a flashlight bulb. Position the long core in the engine coil, tighten the setscrew, and slowly bring the flashlight bulb and coil down over the core. An interesting variation is to try the same thing with the capacitor shorted out by means of a jumper across the two capacitor pin jacks. The increased brilliancy of the bulb with the capacitor in the circuit shows how much

more efficiently a.c. circuits operate at resonance.

Another intriguing experiment using the transformer principle is the repulsion coil. Secure a piece of  $\frac{3}{8}$ "-i.d. aluminum tubing 2" long. Place the tubing over the long core, turn the switch on, and it will shoot skyward. Adjust the center core to get maximum upward thrust if necessary.

The transformer principle involved here is that of mutual induction where a varying current flowing in a coil induces a current in another coil placed in the same magnetic field, such as the primary and secondary of a transformer. The induced current is always in an opposite direction to the original current; thus, the magnetic fields set up by the two currents will be in opposition. The aluminum tubing acts like the secondary of a transformer, and, since it is free to move, opposing magnetic fields send it flying.

A similar piece of aluminum tubing 3" long can be made to oscillate up and down the center core for approximately 8" by adjusting the core to proper height. The height is critical— $\frac{1}{16}$ " either way may prevent it from oscillating.

If you have an a.c. voltmeter with a maximum range of at least 500 volts, it can reveal some startling facts about series resonant circuits. Connect the meter to  $J3$ - $J4$  across the coil and adjust the long center core until the meter gives a maximum reading. Change the voltmeter to the capacitor jacks  $J1$ - $J2$  and note the reading. Readjust the center core until the coil and capacitor voltmeter readings are the same. The circuit is now at resonance; about 400 volts should be indicated across each unit.

In a series resonant circuit such as this, the maximum current will flow at resonance. At 60 cycles, the reactance of the capacitor bank comes to about 250 ohms; and at resonance, the reactance of the coil will also be 250 ohms. However, at resonance, these reactances cancel one another—the current flow is limited only by the small resistance in the circuit. It is this current flow in combination with the reactances of the coil and capacitor—which may be said to build up the voltage by "handing it back and forth"—that accounts for the exceptionally high counter electromotive voltages. —30—

# DOUBLE BONUS SALE

**FREE**

WORTH OF

- Transistors
- Diodes
- Rectifiers
- Knobs
- Condensers
- Coils, etc.

**\$25**

Include 25¢ for handling

PLUS

**FREE**

**\$1**

POLY PAK OF YOUR CHOICE

## BOTH FREE WITH EVERY \$10 ORDER

- 4 —2N155 TRANSISTORS, or equals, T13 cases \$1
- 2—800 MC. 2N709 NPN Silicon planar TO46 ... \$1
- 3 2N711 300MW. 300 MC, PNP MESA, TO18 ... \$1
- 1 40W. 2N1648 TRANS'TR NPN MESA, ... \$1
- 2 25-AMP SILICON RECTIFIERS, ... \$1
- 4 ZENER REFERENCES, 1N429, 6-volt, silicon \$1
- 2 "TINY" 2N1613 2W. 100MC, TO46 case, npn \$1
- 7 500MC TRANS'TRS, 2N964, mesas, pnp, TO18 \$1
- 10 "PIN HEAD" TRANSISTORS, if. H, pnp ... \$1
- 4 2N43 OUTPUT TRANSISTORS, by GE, pnp, TO5 \$1
- 4 2N333 NPN SILICON transistors, by GE, TO5 \$1
- 8 2-6Amp RECT's studs, silicon, 50 to 400V \$1
- 10 MICRO DIODE ZENER gold axial by Transiron \$1
- 4 4-WATT PLANAR TRANS'TRS, 2N497, 2N498 \$1
- 4 2N35 TRANSISTORS, npn, by Sylvania; TO22 \$1
- 6 "MICRO" TRANSISTORS, 2N131's, 1/16", rf \$1
- 4 CK721 TRANSISTORS, pnp, aluminum case ... \$1
- 10 1000 MC-1N251 GERMANIUM DIODES ... \$1
- 5 30MC TRANSISTORS, like 2N247, Sylvania ... \$1
- 85 W. TRANSISTOR, silicon npn mesa, 2N424 ... \$1
- 5 SUN BATTERIES TO 1 1/2" sizes, lite sensitive \$1
- 15 PNP SWITCHING TRANSISTORS, asstd. TO5 \$1
- 10 NPN SWITCHING TRANSISTORS, 2N338, 440 \$1
- 15 PNP TRANSISTORS, CK722, 2N35, 107 ... \$1
- 15 NPN TRANSISTORS, 2N35, 170, 440, ... \$1
- 30 TRANSISTORS, rf, audio, no test, TO5 ... \$1
- 4 35-W. TRANS'TRS, 2N1434, CBS, TO10, stud \$1
- 2 2N708 SILICON 400MC NPN PLANAR, TO46 \$1
- 10 POPULAR CK772 TRANSISTORS, pnp, no test \$1
- 5 2N107 TRANS'TRS, by GE, pnp, test, audio pak \$1

PARTS BY THE POUND

500-1000 pcs

ONE POUND DISCS **4<sup>88</sup>**

TRANSISTORS

**100 for \$2<sup>98</sup>**

Power, Audio, RF, untested

- 4 2N170 TRANSISTORS, by GE, npn for gen'l rf \$1
- 25 TOP HAT RECTIFIERS 750 ma silicon, 50-400V \$1
- 25 GERMANIUM & SILICON DIODES, no test ... \$1
- 1 85W SILICON PWR TRANS'OR, npn, like 2N1212 \$1
- 6 "TEXAS" 750 MA 400V RECTIFIERS, , leads \$1
- 3 TRANSIRON TRANS'TRS. 2N341, 42, 1W, npn \$1
- 4 200 MC, PNP MESA, TO18 TRANSISTORS ... \$1
- \$25 RELAY SURPRISE, sealed, tiny types ... \$1
- 3 INFRA-RED DETECTORS, with leads ... \$1
- \$25 SURPRISE PAK: transistors, rect, diodes, etc. \$1
- 40 PRECISION RESISTORS,  $\frac{1}{2}$ , 1, 2W, 1% values \$1
- 30 CORNING "LOW NOISE" resistors, asst. ... \$1
- 60 TUBULAR CONDENSERS, to .5mf, to 1Kv, asst \$1
- 40 DISC CONDENSERS, 27mf to .05mf to 1KV \$1
- 60 TUBE SOCKETS, receptacles, plugs, audio, etc. \$1
- 30 POWER RESISTORS, 5 to 50W, to 24 Kohms. \$1
- 50 MICA CONDENSERS, to .1mf, silvers tool ... \$1
- 10 VOLUME CONTROLS, to 1 meg, switch tool \$1
- 10° ELECTROLYTICS, to 500mf, asst FP & tubulars \$1
- 50 RADIO & TV KNOBS, asstd, colors & styles ... \$1
- 10 TRANSISTOR ELECTROLYTICS: 10mf to 500mf \$1
- 50 COILS & CHOKES, if, rf, ant, osc, & more ... \$1
- 35 TWO WATERS, asst incl: A.B. 5¢ tool ... \$1
- 75 HALF WATERS, asst incl: A.B., 5¢ tool ... \$1
- 60 HI-Q RESISTORS,  $\frac{1}{2}$ , 1, 2W, 1% & 5% values \$1
- 10 PHONO PLUG & JACK SETS, tuners, amps ... \$1
- 50 TERMINAL STRIPS, 1 to 8 solder lug types ... \$1
- 30 "YELLOW" MYLAR CONDENSERS, asstd val \$1
- 60 CERAMIC CONDENSERS, discs, npo's, to .05 \$1
- 3-TRANSISTOR SUBMINIATURE AMPLIFIER \$1
- 4 TRANSISTOR TRANSFORMERS, asst, worth \$25 \$1
- 1 FILAMENT TRANSFORMER, 117 to 6.3vct, 3A \$1
- 3 GEIGER COUNTER DETECTOR, tubes, assorted \$1
- 40 WORLD'S SMALLEST CONDENSERS to .05mf \$1

Full Leads Factory Tested & Gtd! U.S.A. Mfg.

**POLY PAKS**

TERMS: send check, money order. Include postage—avg. wt. per pak 1 lb. Rated net 30 days. C.O.D. 25% P.O. BOX 942H

SO. LYNNFIELD, MASS.

"PAK-KING" OF THE WORLD



## GOV'T. SURPLUS ELECTRONIC BARGAINS

SCR-625 Mine Detector (treasure locator) new, with btrys. ....	\$ 45.00
4 Conductor Wire, flat, roll 150 feet. ....	1.50
Carbon Mike, Canadian Air Force, new, noise cancelling British Snopescope Tube, new, w/specs. (see in dark) .....	1.25 4.00
US Snopescope Tube #6032 w/sheet. ....	6.50
Infra Red Filter (use on lights) passes infra red. ....	1.75
Infra Red Detector Capsule new .....	1.25
T-45 Air Force Lip Mike (carbon) .....	.75
T-30 Air Force Throat Mike (makes underwater intercom) .....	.50 1.00
Polaroid Polarizing Filters 2 sheets 5x5 inches. ....	4.50
SCR Light Dimmer Kit with instructions. ....	3/1.00
Epitaxial Transistors 300 mc, TO-18, like 2N960. ....	2/1.00
100 Watt Power Transistors like 2N277 .....	1.00
SCR 100 PIV 20 amps. .\$.125 50 PIV 20 amps. ...	7.50
Transistors Factory Marked, Your Choice 75¢ each 12 for .....	2N339-2N340-2N341-2N342-2N343-2N497-2N498- 2N547-2N548-2N549-2N551-2N552-2N657-2N728- 2N755-2N754-2N841-2N843-2N1117-2N1206 .60
Prism, Pocket Rainbow, hold in sun for spectrum. ....	225.00
M-3 Military Infra Red Sniperscope, operational. ....	1.50
Selenium Sun Cells electricity from sun, 5 with book	1.00
3AP1 Oscilloscope Tube .....	1.35
Crystal Mike w/cord & plug, for tape recorders, etc. ...	1.25
Radiosonde Transmitter w/tubes, new. ....	.60
Dynamic Earphone hearing aid type, w/cord & plug. ...	35.00
Wired Memory Planes 4096 .\$.12.50; 8192 .\$.15.00; 16,384. ....	200/1.00
IBM Ferrite Memory Cores, loose, with spec sheet .....	25¢

Above is a sampling from our 80 page catalog. Send 25¢ for catalog. All material listed FOB Lynn, Mass. (you pay shipping).

**JOHN MESHNA, JR.**  
21 ALLERTON ST., LYNN, MASS.

CIRCLE NO. 15 ON READER SERVICE CARD

## Shotgun Sound Snooper

*(Continued from page 64)*

cluster with a 6-32 x 3/8" machine screw and bolt. Install the front bracket the same way, and slide the horizontal support bar between the brackets, aligning the holes in the bar with the lower ones in the brackets. Bolt the horizontal bar in place along with the angle bracket for mounting the microphone to the pan head of a camera tripod. Now fit the microphone enclosure over the tubes; it can be taped on if necessary with a strip of masking or metalized Mylar tape around the enclosure and the rear support bracket. The Mylar tape is not necessary, but looks better.

**The Amplifier.** Weak or distant sounds naturally require a high-gain amplifier. Tube type amplifiers, because of their inherent hum at high gain settings, definitely are not recommended. The five-transistor Lafayette PK-544 is an ideal choice for this purpose, and the cost is low. The high-impedance microphone cartridge is matched to the low-impedance amplifier input with a transformer. As 8-11 ohm output transformer is an integral part of the PK-544. The high-impedance output shown in the schematic on page 64 is optional; *T2*, *S2*, and *J3* may be omitted if low-impedance output will suffice.

The PK-544, *R1*, *T2*, *S2*, and *J1*, *J2*, and *J3* are mounted in half of a 2 1/8" x 3" x 5/4" aluminum box (LMB #136). As a matter of convenience, the authors first mounted input transformer *T1* to the board of the PK-544 amplifier. To do this, you bend off the mounting tabs of the transformer. Then apply quick-drying cement to the bottom of *T1* and to an open area on the amplifier board near the input leads. Mount transformer *T1* in this area.

When the cement is dry, remove the PK-544 input leads where they fasten to the board. Referring to the schematic, trim the low-impedance leads of *T1* and solder them to the board where the original input leads were attached. The high-impedance primary of *T1* is later connected to *J1*.

**ERSIN  
MULTICORE  
5-CORE SOLDER**

ONLY **69c**

BUY IT AT RADIO-TV PARTS STORES

MULTICORE SALES CORP., WESTBURY, N.Y. 11591

CIRCLE NO. 18 ON READER SERVICE CARD

As shown in the photo on page 64, the PK-544 is mounted with four 4-40 x 5/8" machine screws and extra nuts to the top of the box. Tighten the screws with nuts, then use eight more nuts, four above and four below, to mount the board so it is well away from the metal box. Mounting holes are already drilled in the PK-544; disregard the mounting hardware that comes with it.

Drill holes in the front of the box for mounting the three jacks, controls R1-S1, and transformer T2. Drill a hole in the bottom of the box for the battery mounting bracket which is made of a piece of scrap aluminum. Referring again to the photo and schematic on page 64, mount and wire the remaining components, cutting any excess leads. In general, it's a good idea to follow the arrangement shown to avoid possible feedback problems.

The bottom section of the box is fastened to the horizontal support bar of the tubular pickup unit by means of two 6-32 3/8" screws and matching nuts. Place the top section of the box with the mounted amplifier components onto the bottom section, fasten with the screws provided, and the completed unit is ready to use.

**Operation.** Operation of the "Shotgun Sound Snooper" is simple—just connect a pair of headphones and turn on the amplifier, adjusting the volume control carefully to avoid painful sound volume. Earplugs or single phones are not suitable for critical listening. For best results, use good-quality dual headphones.

The tubular mike must be aimed toward the location from which sound pickup is desired—sight along the tops of the tubes and turn the volume up gradually. Picking up weak distant sounds amidst other distracting sounds becomes much like trying to listen to a newscast in a room filled with noisy people. It becomes necessary to mentally "tune out" the unwanted sound in order to concentrate on the news.

Wind has the effect of carrying sound, so straight-on reception is not always possible. Under windy conditions, the unit should be panned until the best reception is achieved as determined by ear. Noisy winds can spoil listening—especially if the tube ends cannot be sheltered a bit—but moderate wind noise

# COLOR CODED NUTDRIVER SETS

no fumbling..  
you reach for  
the right one  
every time!



No. 17  
HANDY  
BENCH STAND

- 7 Most-used sizes — 3/16" thru 3/8"
- High carbon steel, polished and plated
- Precision fit case-hardened sockets
- Shockproof plastic handles (UL)
- Large, readable size indexes

No. 127  
SPACE-SAVING  
WALL RACK  
(Lockable)

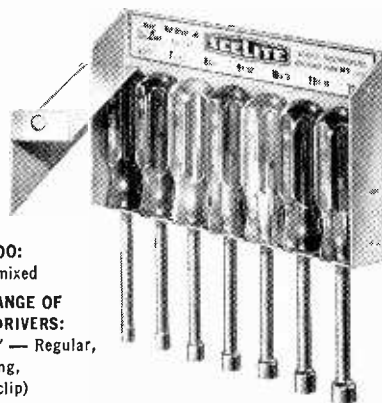

**OTHER SETS, TOO:**  
hollow-shaft or mixed

**PLUS A FULL RANGE OF SEPARATE NUTDRIVERS:**  
3/32" thru 3/4" — Regular,  
Stubby, Extra-long,  
Midget (Pocket clip)

available through leading electronic distributors

## XCELITE®

XCELITE INC. • 54 BANK ST., ORCHARD PARK, N. Y.

Send free literature on nutdriver sets.

name \_\_\_\_\_

address \_\_\_\_\_

city \_\_\_\_\_ state & zone \_\_\_\_\_

CIRCLE NO. 32 ON READER SERVICE CARD

# Olson

\* **FREE**

\*  
Fill in coupon for a **FREE** One Year Subscription to **OLSON ELECTRONICS'** Fantastic Value Packed Catalog—Unheard of **LOW, LOW PRICES** on Brand Name Speakers, Changers, Tubes, Tools, Stereo Amps, Tuners, CB, and other Values. Credit plan available.

NAME \_\_\_\_\_  
ADDRESS \_\_\_\_\_  
CITY \_\_\_\_\_ ZONE \_\_\_\_\_ STATE \_\_\_\_\_

If you have a friend interested in electronics send his name and address for a **FREE** subscription also.

**OLSON ELECTRONICS**  
INCORPORATED

362 S. Forge Street Akron, Ohio 44308

CIRCLE NO. 20 ON READER SERVICE CARD

## EARN YOUR DEGREE in ELECTRONICS ENGINEERING at home

Our A.S.E.E. degree is recognized the world over by personnel men in the electronics industry. Our graduates are always in demand.

College level HOME STUDY courses—taught so that you can easily understand them. Continue your education. . . . Earn more in the highly paid electronics industry.

Learn about Missiles, Computers, Transistors, Automation, complete electronics.

Over 27,000 graduates now employed by industry. Resident school also available at our Chicago Campus.—Founded 1934.

Send for our **FREE** course catalog.

**AMERICAN INSTITUTE OF  
ENGINEERING & TECHNOLOGY**

1137-1139 West Fullerton Pkwy.—Chicago 14, Illinois

CIRCLE NO. 2 ON READER SERVICE CARD

can be cut down by draping the mike with a cloth.

If you enjoy experimenting, you'll find the "Shotgun Sound Snooper" a unique, fascinating project. Endless variations are possible, of course—in tube length and diameter, in the microphone cartridge, the amplifier, etc. Just as endless are the applications you'll find for the microphone. Construction is easy, and the cost is reasonable. Don't delay! —30—

### Build Panic Alarm

(Continued from page 13)

behind a 2¼" cutout, and a scrap of perforated sheet metal stock is painted red and used as the speaker grille. A matching 2¼" round hole is cut in the panel to allow the bulb of the 25-watt lamp to protrude. The balance of the components are mounted on a 2¾" x 6½" piece of Vector perforated breadboard stock, which is secured to the bottom of the cabinet using ½"-long, ⅜"-diameter, internally threaded brass stand-off posts.

Although assembly is not especially crowded, care must be exercised in the placement of components to insure adequate clearance for the 25-watt lamp and the speaker. The writer used brass eyelets for component connection; push-in terminals may be used if desired, however. A socket was not used for the 25-watt lamp in the writer's model. Instead, the lamp was inserted in position with the base against the perforated board, eyelets were installed in the board and #16 solid copper wire used to secure the lamp base and make the required connections. Since brass—instead of the more common aluminum—is used in the base of the red-frosted lamp, soldering the lamp in place provides a simple and effective method of mounting.

**Testing and Adjustment.** Check your work carefully, using an ohmmeter to test for continuity and the absence of shorts. Be sure that no portion of the circuit is shorted to the metal cabinet. When you're satisfied that the wiring is correct, apply power to the unit. The 25-watt lamp should glow at approximately half brilliance and the 50C5 heat-

er should light. A voltmeter connected across capacitor *C5a* should measure approximately 150 volts d.c. Now brace yourself and push the panic button. Relay *K1* should close and a *very* loud rising and falling audio tone should be heard from the speaker. Lamp *I1* should flicker at a rate corresponding to the warble of the tone and lamp *I2* should appear to glow continuously.

The time constants of the two neon lamp oscillators have been selected for optimum results. However, you may want to change the frequency of the output tone or the rate of warble. To increase the rate of warble, reduce the value of resistor *R2*; to decrease the rate of warble, increase the value of this resistor. Reduce the value of resistor *R3* to increase the frequency of the output tone, and increase the value of this resistor to reduce the frequency. You will note some interaction between the two oscillator circuits, and trial and error adjustment of the resistor values may be required to obtain exactly the effect you desire.

When the alarm functions to your satisfaction, button up the project. Decals will serve to give it a commercial appearance, and a very light coat of clear spray lacquer will protect the decals after they have been applied.

Furnishing application instructions for the panic alarm would be gilding the lily. Analyze the moods of your boss, and when the prognosis is favorable, introduce the panic alarm. —50—

## Build the Bi-Coupler

(Continued from page 43)

The area at the top, sides, and rear of each speaker should be padded, but anything beyond this is a matter of taste. The top is screwed into place through the sides, fronts, and rear partition—don't use glue here, as you may want to make the speaker change for which this enclosure was planned.

The final touches are up to you. The author's Bi-Coupler was wrapped in grille cloth and wood trim was added at top and bottom as shown in the photos.

# LATEST SAMS BOOKS FOR EVERYONE IN ELECTRONICS

## Use This Handy Order Form

- Electronic Gadgets for Your Car.** Practical projects for building a tachometer, transistorized battery checker/charger, handbrake protector, other automotive electronic devices. Order **CAR-1**, only... **\$2.95**
- CB Radio Construction Projects.** Complete details for building S-meter, portable antenna, pocket monitor receiver, selective call system, SWR meter, modulation monitor, etc. Order **CBG-1**, only... **\$2.50**
- Hi-Fi Projects for the Hobbyist.** Improve your present hi-fi system—build low-cost rumble filter, noise filter, hi-gain antenna, transistorized mike preamp, FM tuner, tape recorder, etc. Order **HFF-1**, only... **\$2.50**
- Amateur Radio Construction Projects.** Shows how to build 40-80 meter novice transmitter; 30-watt, 15, 40, 80 meter transmitter; crystal-controlled converters, and other ham gear. Order **ARP-1**, only... **\$2.50**
- ABC's of Electronics.** ELW-1.....\$1.95
- How to Read Schematic Diagrams.** RSD-1.....1.50
- Electronics For the Beginner.** BHJ-1.....3.95
- Having Fun With Transistors.** THF-1.....2.50
- Radio Receiver Servicing.** RS-2.....2.95
- Transistor Ignition Systems Handbook.** IGS-1.....2.50
- Garage Door Openers.** GDO-1.....2.95
- Modern Dictionary of Electronics.** DIC-2.....6.95
- So You Want To Be a Ham.** HAM-3.....2.95
- TV Servicing Guide.** SGS-1.....2.00
- ABC's of Hi-Fi and Stereo.** HSF-1.....1.95
- ABC's of Short-Wave Listening.** SWL-1.....1.95
- ABC's of Citizens Band Radio.** ACR-1.....1.95
- Electronic Games & Toys You Can Build.** EGT-1.....2.95
- Science Projects in Electronics.** SPJ-1.....4.95
- Practical Projects in Radio Electronics.** RSM-1.....4.95
- Science Projects in Electricity.** SPE-1.....2.95
- Computer Circuit Projects You Can Build.** BOC-1.....2.95
- Tape Recorders—How They Work.** TRW-2.....3.95
- Electronic Experiments & Projects.** ESE-1.....2.50
- ABC's of Transistors.** TRA-1.....1.25
- ABC's of Electronic Organs.** ECO-1.....1.95
- ABC's of Ham Radio.** HAP-2.....1.95
- ABC's of Computers.** ABC-1.....1.95
- Electronic Servicing For the Beginner.** BSJ-1.....2.95
- ABC's of Television Servicing.** STA-1.....1.95
- Short-Wave Listeners Guide.** SLG-1.....1.25
- How to Repair Small Appliances.** APP-1.....2.50
- Know Your VOM-VTVM.** KVM-1.....2.50
- Automotive Electronics Test Equipment.** AEL-1.....2.50
- ABC's of Electronic Test Equipment.** STE-1.....1.95
- 101 Ways to Use Your Oscilloscope.** TEM-2.....2.50
- Electronic Musical Instrument Handbook.** EMI-1.....2.50
- Citizens Band Radio Handbook.** CBH-2.....2.95
- Sams International Code Training System.** CTG-1.....6.95
- Handbook of Electronic Tables & Formulas.** HTF-2.....3.95
- Electronics Math Simplified.** 2 Vols. MAT-20.....7.95
- Tube Substitution Guide.** TUB-8.....1.50
- Understanding Electronic Components.** UEC-1.....2.95
- Understanding Electronic Circuits.** UEW-1.....2.95



**FREE!** Ask for the Sams Booklist, describing over 300 important books.

**FREE!** Index to Photofact, world's finest circuit data on 65,000 TV & radio models.

## HOWARD W. SAMS & CO., INC.

Order from any Electronic Parts Distributor, or mail to Howard W. Sams & Co., Inc., Dept. EX-10 4300 W. 62nd St., Indianapolis, Ind. 46206

Send books checked above. \$ \_\_\_\_\_ enclosed.

Send FREE Booklist       Send Photofact Index

Name \_\_\_\_\_

Address \_\_\_\_\_

City \_\_\_\_\_ State \_\_\_\_\_ Zip \_\_\_\_\_

IN CANADA: A. C. Simmonds & Sons, Ltd., Toronto 7  
CIRCLE NO. 26 ON READER SERVICE CARD

**Hooking-Up.** Assuming your speakers are 8-ohm units, you can connect them in parallel to match your amplifier's 4-ohm output, or in series for a 16-ohm output. For stereo, of course, each speaker goes to its individual 8-ohm output. Again, for optimum separation, you may want another speaker for stereo, but you can settle back and enjoy your first Bi-Coupler until your system grows its second one. -50-

**For Greater Safety**  
*(Continued from page 16)*

inadvertently leaving the emergency switch on. Figure 2, page 16, shows the necessary changes for a four-light flashing switch.

The most convenient way to connect the leads from the emergency switch to the turn-signal switch leads is to strip the free ends about  $\frac{3}{8}$ " , fan out the strands, and insert the lead into the

socket half of the proper bullet connector. Then reassemble the connector, making sure no bare wire is left exposed.

To keep from distorting the connectors, light gauge wire (#22 or #24) should be used on the emergency switch. Since these leads will probably be less than a foot long, no appreciable voltage drop will be introduced. To make the job even easier, it's a good idea to prewire the switch with the proper length leads for the mounting location chosen, then mount the switch.

The author's car, a 1962 Ford, already had cutouts in the lower face of the instrument panel for mounting accessory controls. These were concealed by an aluminum trim panel, making it easy to bore a hole for a three-pole rotary switch. To give the installation more of a built-in look, a matching replacement knob was purchased and the switch shaft turned down to fit into it.

No matter how simple or elaborate your installation, the important thing is the large amount of safety that can be bought with a light-flashing switch costing literally pennies. -50-

# CLASSIFIED MARKET PLACE

## FOR SALE

**RESISTORS**, newest type metal-film, Copper Circuit Board, Capacitors, Barrier Terminal Blocks, Farnsworth Electronic Components, 88 Berkeley St., Rochester, N.Y.

**TRANSISTORIZED** buried or concealed pipe, cable finders. Free information. Relco-D4, Box 10563, Houston 18, Texas.

**PRINTED CIRCUIT** Boards. Hams, Experimenters. Catalog 10¢. P/M Electronics, Box 6288, Seattle, Wash. 98188.

**EXPERIMENTERS' CATALOG**—TV Camera Parts, Transistors, Tubes, Diodes, Relays, Transformers. Spera Electronics, 37-10 33rd Street, Long Island City, New York.

**BUILD THE SHOTGUN SOUND SNOOPER**—described this issue. Aluminum tubing \$10.00 plus \$1.50 packing and postage. Penna. residents include 50¢ sales tax. Payment must accompany order. J.R.S., 646 West Market Street, York, Penna. 17404.

**AMAZING GLOBAL WRIST WATCH!** 24-hour **WORLD/LOCAL** Time Conversion. Brochure Free. **NORLUND**; 7635 Irving Park, Chicago, Ill. 60634.

**ASSEMBLE** components easily. Magnasighter \$7.50. Brochure. Magnasighter, 2021 Lemon Heights, Santa Ana, Calif.

**RESISTORS**, Component boards, Meters, Instruments. Ames Surplus, 4723 Lincoln Way, Ames, Iowa 50010.

**SURPLUS** Buys, transistors, capacitors, diodes and miniature electronic parts. Send for free catalog. **ELECTRONIC CONTROL DESIGN CO.**, P. O. Box 1432-T, Plainfield, N.J. 07061.

## TAPE AND RECORDERS

**RENT STEREO LP's**, Record Those Tapes Yourself. Details—Varmint Distributing, Silvis, Ill. 61282.

## TREASURE FINDERS

**NEW** Supersensitive transistor locators detect buried gold, silver, coins. Kits, assembled models. \$19.95 up. Underwater models available. Free catalog. Relco-A45, Box 10563, Houston 18, Texas.

## BOOKS

**15¢ BOOKS 7** for \$1.00 Postpaid. Catalog send stamp. M & M Books, 536 Tracy, Peoria, Ill. 61603.

---

## INSTRUCTION

**FREE** Career Guide to success in Electronics, Automation, Practical "job oriented" home study training. Beginners, intermediate advanced college level. Tuition refund surety. Since 1931. Write Central Technical Institute, Dept. 16015, 1655 Wyandotte, Kansas City, Mo. 64108.

**LEARN** Morse International Code Alphabet in Half Hour. Mail \$2.00 check or money order for Laminated, Pocket-Size, Fifty Word Mnemonic to: **MNEMONICS ASSOCIATES**, 56 Grand Street, White Plains, New York.

**ELECTRONIC** Courses. Industrial training programs now released to the public. Inexpensive. Subjects include Fundamental Electronics, Transistors, Digital Computers, Synchros, etc. Ideal for experimenters and hobbyists. Free information. Huntington Institute, division of Lantec. Box 2244E, Huntington Park, Calif.

**LEARN CODE THE V METHOD FIRSTS IN**—Guided Sending, always available—Oscillator in Key base (no wires)—Fundamental 455 plus 1250 Kc.—Variable Audio—Transmit to any AM Radio or Speaker connect—No tuning, switching, or beat Frequency—3" Tapes Capstan or Rim drive—12" color coded records—Multiple choice of true letters—Special lesson papers—No visual sight of Dots and Dashes—No comparison one letter to another. Oscillator Ideal signal insert tester. Write—**PAGE ELECTRONICS INSTITUTE**, 1158 WEST 54 ST., LOS ANGELES, CALIF. 90037.

---

## HIGH FIDELITY

**ARISTOCRAT** of **SPEAKER SYSTEMS** for perfectionists. "Designing the Ducted Post Bass Reflex Enclosure", \$1.00. How to double the bass output of any loudspeaker. Formulas, charts, trade secrets. Also free literature on guaranteed basic speaker systems, unbelievable prices. ESW Speaker Systems, 1602 Alta, Wichita, Kansas 67216.

---

## RADIO-TV

**CONVERT** any television to sensitive, big-screen oscilloscope. Only minor changes required. No electronic experience necessary. Illustrated plans, \$2.00. Relco-A45, Box 10563, Houston 18, Texas.

**TRANSISTORIZED** Two Band Radio Kit, Tunes, Broadcast. Foreign, Police, Aircraft, Phone Stations From all over the World. Tube and Transistor, Included \$5.00. Phones \$2.00. **EKERADIO**, Box 131, Temple City, Calif.

---

## BUSINESS OPPORTUNITIES

**SIMPLE**, pleasant mailorder can net \$12,000 year. Write Rutward 2683 Bryant, Columbia Station, Ohio.

**SELL CB EQUIPMENT**—Dealerships available to aggressive people who can sell Citizens Band Radio full or part time. Knox Electronic, Dept. EF5, Galesburg, Ill. 61401.

**SEEKING ADDITIONAL OUTLETS FOR YOUR BUSINESS OPPORTUNITIES?** If so, your ad belongs here. Write today for complete information to: Hal Cymes, Classified Advertising Mgr., **ELECTRONIC EXPERIMENTER'S HANDBOOK**, Dept. F-65, One Park Avenue, New York, New York 10016.

---

## MUSICAL INSTRUMENTS

"**PRACTICAL** Violin Making" With Patterns \$2.00 Supplies. Chelsea Fraser, 2025 Stark, Saginaw, Mich.

---

## AUTO SUPPLIES & EQUIPMENT

**IGNITION**. Delta's Patented Mark Ten Capacitive Discharge Ignition System, the world's largest selling SCR Ignition, fits all cars. Easy assembled Kit \$34.95, assembled \$49.50. Acknowledged by engineers as the ultimate ignition system in feature articles in **POPULAR ELECTRONICS**, **ELECTRONICS WORLD**, **ELECTRONICS**, and other engineering publications. Proven on thousands of cars, trucks, and boats. Connects to standard coil, no rewiring. Saves gas and 80% of ignition tuneups. Plugs last 5 times longer. Give you and your car a "treat", order your Mark Ten today. Satisfaction Guaranteed. Shipped postpaid. State Voltage & Polarity. Delta Products, Inc., P. O. Box 1147, Grand Junction, Colorado.

---

## ELECTRONICS

**FREE** Catalog—Electronic Parts and Equipment. Bigelow Electronics, Bluffton, Ohio.

**KITS**, Diode Radio, \$1.25, Audio Amplifier \$1.50, Solar Powered Radio \$3.95, Wireless Transmitter \$4.95. **LECTRONIX**, Box 1067 EEH, Southgate, Mich. 48195.

---

## PLANS & KITS

**WEBBER** Labs. Transistorized converter kit \$5.00. Two models using car radio 30-50Mc or 100-200Mc, one Mc spread. Easily constructed. Webber, 40 Morris, Lynn, Mass.

**KIT-OF-THE-MONTH CLUB**, New, Unique, low cost kits. Free Information, Box 44718-KG, Los Angeles, Calif. 90044.

---

## MISCELLANEOUS

**FREE 'HIT' SONG** gift for you, friends. Send names, addresses: Nordyke Songs, 6000-3A Sunset, Hollywood, Calif. 90028.

**INCREDIBLY COOL-SMOKING PIPE** Unique air-cooled stem makes the difference, removes hot moisture and tars. You agree or money returned. Inquire and receive free pipe cleaners. Write: Monarch Pipes, Dept. N, Box 1431, Tulsa, Oklahoma.

**HORSE RACE COMPUTER**. Dial time for each horse. Any distance, Any track. 42 Distances, 91 Tracks listed. Fascinating, Exciting, Fun. \$5.00 Delivered. Lehtonen Computerizer, 914 Pulaski Hwy., Joppa, Md. 21085.

**STELLAR** Aberration Einstein Forgot. \$5.50 Thomas, 105 N. Halifax, Daytona Beach, Fla.

"**LOVE-BUG**." Build her one for Christmas — see what happens! Oolala—I dare you! Easy instructions \$2.00. N-S Enterprises, Dept. LX, 103 W. Agarita, San Antonio, Texas 78212.

**FREE** wine recipes and home brewing supplies catalog. **COUNTRY WINEMAKER**, Box 243EE, Lexington, Mass.

**ARE YOU A CLASSIFIED ADVERTISER?** If you are, and you're looking for media which will produce outstanding responses, then your advertising message belongs in one or all of the Ziff-Davis Electronics Division Annuals or Handbooks.

The 1966 **COMMUNICATIONS HANDBOOK** closes October 25th—on sale December 21st. The Spring 1966 **ELECTRONIC EXPERIMENTER'S HANDBOOK** closes December 28th—on sale January 17, 1966. The Fall 1966 **ELECTRONIC EXPERIMENTER'S HANDBOOK** will be distributed early in October, 1966.

For information concerning rates, circulation and special group discounts, be sure to write today to: Hal Cymes, Classified Advertising Mgr., **ELECTRONIC EXPERIMENTER'S HANDBOOKS**, Dept. F-65, 1 Park Avenue, New York, N.Y. 10016.

# UNUSUAL BARGAINS

## BRAND NEW, INDUSTRIAL SURPLUS NICKEL-CADMIUM CELLS AND BATTERIES

BUY OF THE YEAR!

These hard-to-get, light-weight, 1.2V nickel-cadmium cells in rugged nylon cases have 4-amp. hour capacity. Hundreds of uses for hobbyists, amateur photographers, campers, model builders, etc. By connecting cells in series, you can make battery of any voltage in multiples of 1.2V. Excellent for rechargeable portable lanterns; cycle, scooter, bicycle, and boat lights; camp lights; portable fluorescent and ultra-violet lights; electronic flash units. Model buffs will find cells perfect for powering model boats, cars, etc. Cells have almost unlimited life, will undergo thousands of discharge-charge cycles with practically no deterioration. Quick charge—1/2 hour with proper equipment. Minimum maintenance; just add a few drops of water each year. Small amount of electrolyte used; cell sealed to prevent loss. Delivers almost 100% of output at below freezing temperatures where output is reduced 50% in lead-acid cells. No corrosive fumes given off under any stage of recharge. Can't be damaged by accidental charging in reverse (but not recommended). Cell meas. 6" x 2" x 1/2" (thick, 6 1/2 oz. Stud-type terminals on top 1 1/8" apart, marked for polarity; 6-32 thread, nuts and lock washers.

- ONE 1.2 NICKEL-CADMIUM CELL ..... \$3.95 Postpaid
- Stock No. 40,798-GD
- ONE 6-VOLT NICKEL-CADMIUM BATTERY, 5-cells in stainless steel, strap-type casing. Convenient power source for Edmund's war surplus slipscope (No. 85,157). 6" x 2" x 4". Wt. approx. 2 lbs. Stock No. 70,776-GD ..... \$15.00 Postpaid
- ONE 7.2-VOLT NICKEL-CADMIUM BATTERY COMPLETE WITH CHARGER KIT. Assemble your own portable battery power supply with built-in charger. Excellent for portable movie light. Six-cell battery in stainless steel, strap-type casing; 1.2-volt transformer; charger circuit board consisting of rectifier and automatic regulating circuit (transistorized) which protects against overcharging of battery. Complete with wire, switch, line cord, hardware and instructions. 6" x 6" x 2". Wt. approx. 2 lbs. Stock No. 70,777-GD ..... \$25.00 Postpaid

### Binocular-to-Camera Holder Will Fit Any Camera

Bring distant objects 7 times nearer with a 35mm camera, 7x50 binocular and our NEW CAMERA-TO-BINOCULAR HOLDER. Ideal for long range photos of wildlife, ships, people, planes, etc. Camera and binocular attach easily. Use any binocular or monocular—any camera, still or movie. Take color or black and white shots. Attractive gray erinkle and bright chrome finish. 10" long. Full directions for taking telephotos.

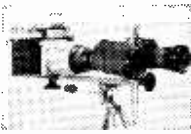

Stock No. 70,223-GD ..... \$11.50 Postpaid

### Bargain! 3" Astronomical Telescope



See the stars, moon, phases of Venus, planets close up! 60 to 180 power—famous Mt. Palomar Reflecting type. Unusual Buy! Equipped with Equatorial mount; finder telescope; hardwood tripod. Included FREE: "STAR CHART"; 272-page "HANDBOOK OF HEAVENS"; "HOW TO USE YOUR TELESCOPE" book. Stock No. 85,050-GD ..... \$29.95 pstd.

4 1/4" Reflecting Telescope—up to 255 Power, All-metal pedestal mount. Stock No. 85,105-GD ..... \$79.50 F.O.B.

Superb 6" Reflector Telescope. Up to 576 Power. Equatorial mount and Pedestal Base. Stock No. 85,086-GD ..... \$199.50 F.O.B.

### EXPLORE THE FASCINATING WORLD OF MAGNETISM

#### NEW 15 MAGNET SAMPLER KIT

##### 11 Shapes! Many Compositions!



Ever taken tomatoes, magnets, etc. pictures using magnet as a brush and iron filings as paint? Surprising new ideas and uses for the bewildering forces of magnetism are continually discovered. Here, in one low-cost kit, you can learn and experiment with varied materials that obscured Magnetite—the natural magnetic ore. Fantastic assortment includes ferrites, ceramics, flexible rubber, alnico in every shape imaginable—up to 20 lbs. pull. Used every day in the modern wonders of magnetic microphones, magnetic processing of bank checks, memory cores for electronic computers, flow meters, immense generators, transformers, motors, etc. All kinds of practical everyday uses, too. Make tool and knife holders, pickup tools, bullet boards, automatic stirrers, magnetic games and puzzles. Your own ingenuity can produce dozens of innovations—perhaps patentable. Sizes range from 3/8" x 7/16" x 7/16" to 3" x 1 1/2" x 1 1/2". Alnico w/handle, U-shaped alnico, three—2 sided ceramic, flexible strip, alnico bar, ceramic, alnico disc w/center hole, 2 lb. alnico cyl. sm., alnico cyl. fl. sheet, 2 baby alnico bar, 3 channel-pipe pole pieces for sm., ceramic magnets, bar magnet keeper, 2 disc magnet keepers, compl. info. and inst.

Stock No. 70,780-GD ..... \$5.00 Postpaid

Order by Stock No.—Send Check or M.O.—Money-Back Guarantee  
EDMUND SCIENTIFIC CO., Barrington, New Jersey

### MAIL COUPON for FREE CATALOG "GD"

EDMUND SCIENTIFIC CO., Barrington, N.J.  
Completely New 1966 Edition, 148 pages.  
Nearly 4000 Bargains.

Please rush Free Giant Catalog-GD

Name.....  
Address.....  
City..... Zone..... State.....



CIRCLE NO. 6 ON READER SERVICE CARD

## ELECTRONIC EXPERIMENTER'S HANDBOOK FALL 1965

READER SERVICE NO.	ADVERTISER	PAGE NO.
1	Allied Radio	33, 34, 35
2	American Institute of Engineering & Technology	146
3	Burstein-Applebee Co	138
19	Conar	139
4	Datak Corporation, The	135
5	Demco	20
33	DeVry Technical Institute	1
6	Edmund Scientific Co	150
7	Electro-Voice, Inc	133
	General Electric	24, 25, 26, 27
	Grantham School of Electronics	137
9	Grove Electronic Supply Company	138
10	Heath Company	117, 118, 119
11	Hy-Gain Electronics Corporation	4
13	International Crystal Mfg. Co., Inc	2
14	Johnson Company, E.F.	20
12	Lafayette Radio Electronics	SECOND COVER
15	Meshna Jr., John	136
16	Miller Company, J.W.	140
17	Milwaukee School of Engineering	141
18	Multicore Sales Corp	136
	National Radio Institute	THIRD, FOURTH COVERS
35	National Technical Schools	21
20	Olson Electronics Incorporated	146
21	Poly Paks	143
22	Progressive "Edu-Kits" Inc	65
23	RCA Electronic Components and Devices	6
24	RCA Institutes, Inc	83, 84, 85
25	Rye Sound Corporation	142
26	Sams & Co., Inc., Howard W	147
27	Scott, Inc., H.H.	38
29	TechPress Publications	142
30	Telex/Acoustic Products	98
31	Vero Electronics Inc	110
32	Xcelite Inc	145
	CLASSIFIED ADVERTISING	148, 149

# 1965

POPULAR ELECTRONICS'

# ELECTRONIC EXPERIMENTER'S HANDBOOK FALL EDITION

## INFORMATION SERVICE

Here's how you can get additional information, promptly and at no charge, concerning products advertised in this Handbook.

- 1.** Tear out one of the perforated postage-free cards. Print or type your name and address where indicated.
- 2.** Circle the number on the card that corresponds to the key number at the bottom of the advertisement that interests you. Key numbers for advertised products also appear in the Advertisers' Index.
- 3.** Simply mail the card. No postage is necessary.
- 4.** Please use this address *only* for requests to manufacturers.

*(Void After January 31, 1966)*

1	2	3	4	5	6	7	8	9	10
11	12	13	14	15	16	17	18	19	20
21	22	23	24	25	26	27	28	29	30
31	32	33	34	35	36	37	38	39	40
41	42	43	44	45	46	47	48	49	50

name \_\_\_\_\_  
(please print)

address \_\_\_\_\_

city \_\_\_\_\_

state \_\_\_\_\_ zip code # \_\_\_\_\_

Check this box if you are a subscriber to  
**POPULAR ELECTRONICS Magazine.**

*(Void After January 31, 1966)*

1	2	3	4	5	6	7	8	9	10
11	12	13	14	15	16	17	18	19	20
21	22	23	24	25	26	27	28	29	30
31	32	33	34	35	36	37	38	39	40
41	42	43	44	45	46	47	48	49	50

name \_\_\_\_\_  
(please print)

address \_\_\_\_\_

city \_\_\_\_\_

state \_\_\_\_\_ zip code # \_\_\_\_\_

Check this box if you are a subscriber to  
**POPULAR ELECTRONICS Magazine.**

*(Void After January 31, 1966)*



FIRST CLASS  
PERMIT NO. 24707  
PHILADELPHIA, PA.

BUSINESS REPLY MAIL  
NO POSTAGE NECESSARY IF MAILED IN THE UNITED STATES

POSTAGE WILL BE PAID BY —

1965 ELECTRONIC FALL EDITION  
EXPERIMENTER'S HANDBOOK

P.O. Box 7895  
Philadelphia, Pa. 19101

# POPULAR ELECTRONICS

...read each month  
by more than  
400,000 electronics  
hobbyists, students  
and experimenters...  
the leading magazine  
in the field  
throughout the world!

FIRST CLASS  
PERMIT NO. 24707  
PHILADELPHIA, PA.

BUSINESS REPLY MAIL  
NO POSTAGE NECESSARY IF MAILED IN THE UNITED STATES

POSTAGE WILL BE PAID BY —

1965 ELECTRONIC FALL EDITION  
EXPERIMENTER'S HANDBOOK

P.O. Box 7895  
Philadelphia, Pa. 19101



# BUILD, EXPERIMENT, EXPLORE, DISCOVER WITH NRI CUSTOM-DESIGNED TRAINING KITS



## BUILD YOUR OWN PHONE/CODE TRANSMITTER

This is just one of seven training kits programmed into NRI's Complete Communications course. You get actual practice in building your own crystal-controlled, phone/code transmitter and putting it on the air. You experiment with modulation, "clamping" circuits, key filters, other aspects of commercial transmitter operation. Can be put on the air simply by attaching an antenna and complies with FCC regulations. As with all NRI training kits, you get the most modern features and parts.

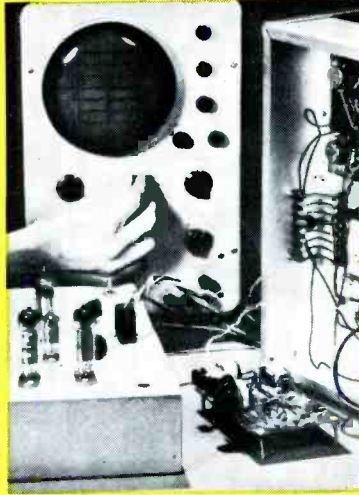

## BUILD ACTUAL ANALOG COMPUTER CIRCUITS

Industry, business offices, the government and military all need trained Electronics Technicians. NRI's Industrial Electronics course prepares you. You progress through 10 carefully designed training kits, topping off your practical experience phase of training by experimenting with feedback control systems, analog computers and digital computer elements. You actually solve problems on this analog computer you build yourself. This is the *practical*, fast way to a good paying, career position.



## BUILD A CUSTOM-ENGINEERED TELEVISION RECEIVER

Want to earn \$3 to \$5 an hour in spare time? Want your own part-time or full-time business? In Radio-TV Servicing you learn to install, maintain, service radios, TV sets, hi-fi and stereo, other home Electronics equipment. In your training are eight training kits, including this complete, modern, slim-line TV receiver. You build it yourself, become familiar with components and circuits, learn servicing procedures . . . and earn extra money as you train. National Radio Institute, Washington, D.C.

### Join the Thousands Who Gained Success with NRI



"I am Frequency Coordinator for the 11th Naval District. The course was priceless." J. J. JENKINS, San Diego, Calif.



"Many thanks to NRI. I hold FCC License, am master control engineer with KXIB-TV." R. L. WOOD, Fargo, N.D.



"I am a Senior Engineering Aide. Without NRI I would still be working in a factory at a lower standard of living." D. F. CONRAD, Reseda, Calif.



**SEE OTHER SIDE** ▶

FIRST CLASS  
PERMIT  
NO. 20-R  
Washington, D.C.

### BUSINESS REPLY MAIL

NO POSTAGE STAMP NECESSARY IF MAILED IN THE UNITED STATES

POSTAGE WILL BE PAID BY

**NATIONAL RADIO INSTITUTE**

**3939 Wisconsin Avenue**

**Washington, D.C. 20016**



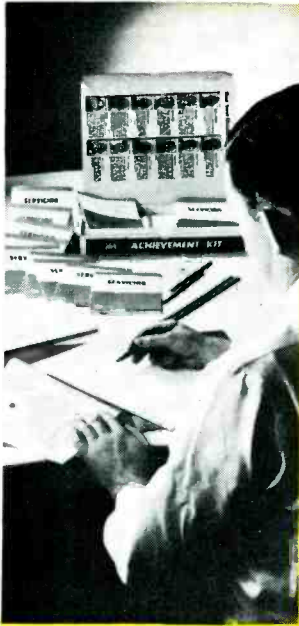

**GET FAST START WITH NEW ACHIEVEMENT KIT**

Delivered to your door—everything you need to make a significant start in the Electronics field of your choice. An outstanding, logical way to introduce you to home-study training. It includes your first set of lesson texts and all the "classroom tools" you need. No other school has anything like the new NRI Achievement Kit.



**ELECTRONICS COMES ALIVE WITH NRI TRAINING KITS**

Nothing is as effective as learning by doing . . . and NRI pioneered the "home lab" technique of training. NRI invites comparison with training equipment offered by any other school. Begin NOW this exciting program of practical learning. Make the skills of the finest Electronic Technicians your own. Mail card below.

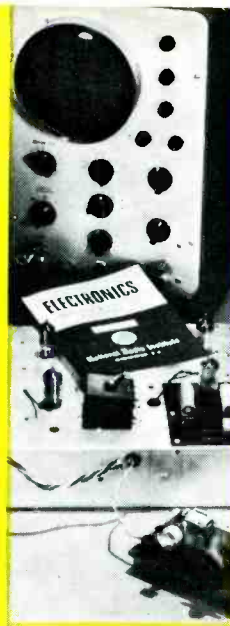

**"BITE SIZE" TEXTS PROGRAM YOUR TRAINING**

Certainly, lesson texts are necessary. NRI's programmed texts are as simple, direct and well illustrated as 50 years of teaching experience can make them. They are carefully programmed with NRI training kits to make the things you read about come alive. You experience all the excitement of original discovery.



**HOBBY? CAREER? MAIL CARD NOW TO NRI**

Whatever your need . . . whatever your education . . . there's an NRI training plan to fit your requirements. Choose from three major courses or select one of seven special courses in particular Electronics subjects. Check the postage-free card below, fill in and mail. National Radio Institute, Washington, D.C.

**DISCOVER THE EASE AND EXCITEMENT OF LEARNING ELECTRONICS THE NRI WAY**

**SEE OTHER SIDE**

National Radio Institute, Electronics Div.  
Washington, D.C. 20016

13-105

Please send me your catalog. I have checked the field(s) of most interest to me. (No salesman will call.)

- |  |   |
|--|---|
| <input type="checkbox"/> TV-Radio Servicing      | <input type="checkbox"/> Basic Electronics          |
| <input type="checkbox"/> Industrial Electronics  | <input type="checkbox"/> Electronics for Automation |
| <input type="checkbox"/> Complete Communications | <input type="checkbox"/> Aviation Communications    |
| <input type="checkbox"/> FCC License             | <input type="checkbox"/> Marine Communications      |
| <input type="checkbox"/> Math for Electronics    | <input type="checkbox"/> Mobile Communications      |

Name \_\_\_\_\_ Age \_\_\_\_\_

Address \_\_\_\_\_

City \_\_\_\_\_ State \_\_\_\_\_ Zip Code \_\_\_\_\_

Accredited Member National Home Study Council



**PICK THE TRAINING PLAN OF YOUR CHOICE AND MAIL CARD FOR FREE CATALOG**



**OUR 50TH YEAR OF LEADERSHIP IN ELECTRONICS TRAINING**