

**ELECTRONICS
HOBBY THEORY
PROJECTS**

C&E HOBBY HANDBOOKS

WPS 36286

\$2.95

ELECTRONICS HANDBOOK

OCTOBER 1986

IN CANADA \$3.50

THE BEST OF THE BEST!

**PREMIERE
ISSUE**

**OSCILLATING
AMPLIFIERS**

**PRIMER ON
BASIC
MAGNETISM**

**80-TUNE
COMPUTER**

**TALE OF
TWO
COMETS**



Lab Test ELECTRONICS HANDBOOK For Yourself

Get switched on

In case you're not all that familiar with us, we're not a publication for electrical engineers and other wizards. No way, ELECTRONICS HANDBOOK is expressly for people who like to build their own projects and gadgets—and maybe get a little knee-deep in tape, solder and wire clippings in the process.

In fact, we have a sneaking suspicion that our readers like us because they think we're just as bug-eyed and downright crazy over great new project ideas as they are. And I guess they're right!

ELECTRONICS HANDBOOK thinks of you who dig electronics as the last of a special breed. It's more than just the "do-it-yourself" angle—it's also the spirit of adventure. In this pre-packaged, deodorized world, building your own stereo system, shortwave receiver, darkroom timer or CB outfit is like constructing a fine-tuned little universe all your own. And when it all works perfectly—it really takes you to another world.

ELECTRONICS HANDBOOK
knows the kinds of projects
you like—and we bring 'em
to you by the truckload!

Ever hanker to build a sharp-looking digital clock radio? Or to hook up an electronic game to your TV? Or an easy-to-build photometer that makes perfect picture enlargements? Or a space-age Lite-Com so you and the family can talk to each other on a light beam? We've got it all to get you started.

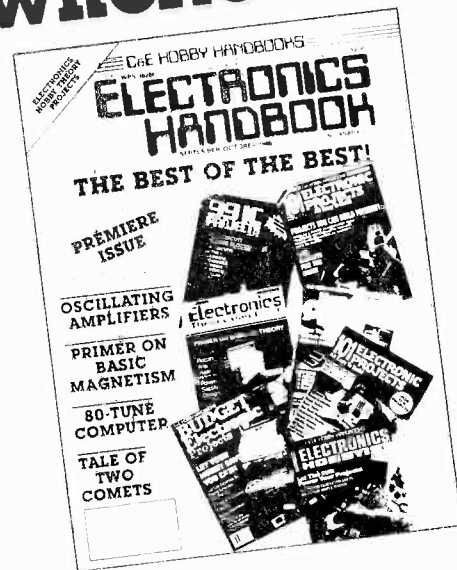

Has your sound system gone blooey just when the party's going great? Do you shudder when your friendly neighborhood electrician hands you the bill? ELECTRONICS HANDBOOK can help.

Of course, we can't make you a master electrician overnight. But we can show you the fundamentals of repair plus maintenance tips.

IF YOU'RE NEW TO ELECTRONICS YOU GET A "BASIC COURSE"!

It gives you a complete, ground-floor lowdown on a variety of important electronic subjects. For example—Understanding Transistors...How Radio Receivers Pull in Signals...Cathode Ray Tubes Explained...How Capacitors Work...Using Magnetism in Electronics, and much, much more!

TRY A FEW ISSUES AND EVALUATE OUR...

• **HOW-TO-DO-IT HELP.** Tips and pointers that add up to money saved. For example—tuning up your tape player...all about radios...whys and hows of turntables...care and feeding of speakers.

• **EXCITING DISCOVERIES.** Whatever your particular interest in electronics, you'll be entering a world of discovery in the pages of the ELECTRONICS HANDBOOK

ELECTRONICS HANDBOOK

PUBLISHER
Don Gabree

ASSOCIATE PUBLISHER
H.M. McQueeney

CREATIVE COORDINATOR
Tony DeStefano

SECRETARY/TREASURER
L. M. Gabree

EDITOR
Hank Scott

COMPUTER EDITOR
Charles Graham

ART DIRECTION
Newgraphics, Inc.

ASSOCIATE ART DIRECTOR
Joe DeStefano

COVER ART
George Mattel

ADVERTISING SALES
C&E Hobby Handbooks
P.O. Box #5148
North Branch, N.J. 08876
(201) 231-1518

Worldwide Publications
(201) 231-1518

Published by C&E Hobby Handbooks, Inc. Editorial and Business address, P.O. Box #5148, North Branch, N.J. 08876 (201) 231-1518. **PERMISSIONS:** Material in this publication may not be duplicated or reproduced in any form without permission. Requests for permission should be directed to—Don Gabree, C&E HOBBY HANDBOOKS, INC. P.O. Box #5148, North Branch, N.J. 08876 (201) 231-1518.

EDITORIAL CONTRIBUTIONS must be accompanied by return postage and will be handled with reasonable care; however, the publisher assumes no responsibility for the return or safety of manuscripts, artwork or photographs. All contributions should be addressed to: PUBLISHER, C&E HOBBY HANDBOOKS, P.O. Box #5148, North Branch, N.J. 08876.

As a service to readers, C&E HOBBY HANDBOOKS publishes available plans and/or information relating to products, techniques of scientific and technological developments. Because of possible variances in the quality and condition of materials and workmanship used by readers, C&E HOBBY HANDBOOKS disclaims any responsibility for the safe and proper functioning of reader-built projects based upon or from plans and/or information published by C&E HOBBY HANDBOOKS.

Second Class Entry applied for. Copyright © 1986 by C&E HOBBY HANDBOOKS, INC.

AMAZING SCIENTIFIC and ELECTRONIC DEVICES

LASER DEVICES

- LC5 BURNING CUTTING CO2 LASER . \$15.00
- RUB3 RUBY LASER RAY PISTOL 15.00
- LRG3 IR LASER RIFLE/PISTOL 10.00
- LGU3 VISIBLE RED LASER RIFLE 10.00
- LHP/LLD LASER LIGHT XMTR/RCVR SYS 10.
- LMC2 BEGINNER simulated VISIBLE LASER 5.

SCIENTIFIC & ELECT

- TCL3 SOLID STATE TESLA COIL 35KV 6.00
- BTC3 250 THOUSAND VOLT TESLA COIL 9.00
- BTC5 1.5 MILLION VOLT TESLA COIL 15.00
- HVM3 125 THOUSAND VOLT DC SUPPLY 8.00
- IOG3 ION RAY FORCE FIELD GUN 8.00
- HEG1 MILLION WATT 500 JOULE SOURCE 10.

ULTRASONIC ACOUSTICAL

- PPF1 PHASOR PAIN FIELD GENERATOR 15.00
- PSP3 PHASOR SHOCK WAVE PISTOL 7.00
- IPG5 POCKET PAIN FIELD GENERATOR 7.00
- RAT2 RAT AND PEST ELIMINATOR 6.00
- HT9 HIGH FREQ LISTENING DEVICE 8.00

SECURITY & PROTECTION

- DEVI DEVASTATING DEVICES 10.00
- PPG1 PHASOR PROPERTY GUARD 15.00
- MFT3 MINI VOICE XMTR 2-3 MILE 7.00
- INF1 INFINITY TRANSMITTER 15.00
- PSW3 PHASOR BURNING STUN WAND 8.00
- PG1 PARALYZING WAND 10.00

WE STOCK ALL PARTS NECESSARY FOR CONSTRUCTION OF THE ABOVE PROJECTS.

• CATALOG CONTAINING HUNDREDS MORE OF ALL NEW AMAZING and FASCINATING PLANS. EASY TO BUILD KITS and ASSEMBLED ITEMS \$1.00. CATALOG INCLUDED FREE WITH ANY OF THE ABOVE PROJECT PLANS. SEND CASH. CHECK, MO, VISA, MC TO:

INFORMATION UNLIMITED
P.O. BOX 716, DEPT. CE AMHERST, NH 03031

KeproClad

by Kepro Circuit Systems, Inc. r.m.

At Home Professional Quality Fine Line PCB's.

Introducing an easy, inexpensive, step by step method for the home production of professional quality printed circuit boards without a major equipment investment—KeproClad, by Kepro, makers of quality industrial equipment and supplies. KeproClad was designed for the home user who needs professional results with:

A Simple Circuit Board;

Use KeproClad unsensitized copperclads. These boards come in 2 popular sizes with 1 sided foil, a marking pen, all for a suggested retail price as low as \$3.50.

A Fine Line Detailed Board;

Use KeproClad photosensitized copperclads. Available in 2 sizes with 1 or 2 sided foil. These copperclads use the latest technology of negative acting dry-film photoresist. This material is rugged, yet holds extremely fine detail. It comes with a pre-measured amount of developer and sells for as little as \$3.90 (suggested retail).

Other KeproClad products such as a photo reversal kit for making negative film, etch, tin plating solution and photo flood lamps are all available at your local distributor. (For the distributor nearest you, call or write:

KEPRO CIRCUIT SYSTEMS, INC.
630 Axminster Drive., Fenton, MO 63026-2992
In MO 314-1630 Toll Free 800-325-3678

SEPTEMBER/OCTOBER 1986

ELECTRONICS HANDBOOK

CONTENTS

3 — EDITORIAL

6 — NEW PRODUCTS

4 — ASK HANK

8 — BOOK REVIEWS

10 — APE SHOOTER

14 — ELECTRONICS TRAINING

18 — LIVE AID

19 — IC PROJECTS FOR EVERYONE

26 — 80 - TUNE COMPUTER

30 — TALE OF TWO COMETS

37 — LATINO MUSICA DIPOLE

40 — THE JUNK BOX SPECIAL

42 — QUARTZ CRYSTAL MAGIC

47 — ONE EVENING WORKSHOP PROJECTS

55 — CASSETTE REPAIR

61 — BASIC COURSE ON MAGNETISM

67 — CIRCUIT FRAGMENTS THAT DO THINGS

73 — INDUCTANCES & CAPACITANCES

78 — AM STEREO

80 — OSCILLATING AMPLIFIERS

85 — SPUN DISHES

87 — BEST BUY WORD PROCESSOR

90 — HOME MICROS FROM TANDY

THE BEST OF THE BEST

Welcome.....to our first issue of ELECTRONICS HANDBOOK!

If you're reading this introduction, you are, more than likely, interested in building "electronic projects" and/or you're interested in expanding your knowledge of electronics, robotics and computers...or maybe both. In either case, you've come to the right place. So, read on and enjoy.

Readers of our previous "Series" of C&E Hobby Handbooks: 101 ELECTRONIC PROJECTS, ELECTRONIC THEORY HANDBOOK, HOME COMPUTER HANDBOOK, ELECTRONIC HOBBYIST, 99 IC PROJECTS and BUDGET ELECTRONIC PROJECTS will recognize their old friends in our new ELECTRONICS HANDBOOK, since we are endeavoring to take the most popular features from each of these titles and combine them into a regular bi-monthly magazine, with an editorial emphasis on "projects for the hobbyist". There will be a wide variety of "projects", many of which, will save the reader money...in their photo darkroom, in their home and on their cars but, most of all, there will be "projects" to build "just for fun...to challenge the readers imagination and creativity. You will find enough "projects" in each jam-packed issue to keep you busy until our next issue appears on your local newsstand. The complexity of the "projects" will vary. Some will be relatively simple and can be completed in a single evening. Others, more complicated, may require an entire weekend.

While we will continue to emphasize the "building of projects" and will endeavor to instruct new readers in various techniques that may be used in building these "electronics projects", we will also delve into some of the "theory" involved in electronics and a better understanding of the electronic/robotic/computer world we live in.

Although the ELECTRONICS HANDBOOK title may be new, most readers will recognize that we are continuing the kind of magazine that they have become accustomed to from the publishers of C&E Hobby Handbooks for the past three years. Like it's predecessors, ELECTRONICS HANDBOOK will be edited for the "experimenters", people who enjoy doing things with their hands and their minds. That's what the ELECTRONIC HANDBOOK will be all about...doing things with your hands as well as your head and that's why we will call it a HANDbOOK. It's no secret that the best way to learn something, and make it stick, is not by just reading about it but by doing it. In this case, by actually building the "electronic projects".

While it appears that many of our readers have some pretty sophisticated equipment on their workbenches, most of our "projects" will only require fundamental skills in the use of everyday hand-tools such as a screwdriver, wire-cutters, pliers, and, of course, a soldering iron. Experienced "project" builders won't be neglected. Each issue of the ELECTRONICS HANDBOOK will have some challenging "projects" for the builders who have acquired the knowledge and developed the skills to tackle the toughies.

For the less skilled, however, or those with less experience, there will be ample "projects" to build and develop skills by joining two or more of the simpler "projects" (circuits) to accomplish new objectives. It won't take long to discover that their accomplishments are limited only by their own imagination. We think that this is a great way to learn about the exciting world of electronics...by having fun while you're doing it.

We plan to include an on-going series on the "Basics of Electronics" in future issues of the ELECTRONICS HANDBOOK, beginning with relatively simple "projects" the readers can build while they learn the "nuts & bolts" of electricity and electronics and going on to one-transistor and one-diode projects which can be very useful and eventually progressing to "projects" which can use several transistors and/or multiple integrated circuits.

There you have it.....pretty ambitious plans but we are looking forward to it.....meanwhile, read on, roll up your sleeves and try some of the "projects" in this issue.....**just for the fun of it.**

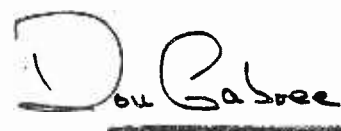

Don Gabree, —Publisher

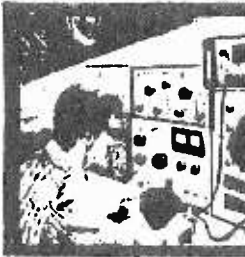

Ask Hank,
He Knows!

Got a question or a problem with a project—ask Hank! Please remember that Hank's column is limited to answering specific electronic project questions that you send to him. Personal replies cannot be made. Sorry, he isn't offering a circuit design service. Write to:

Hank Scott, Editor
G & H HOBBY HANDBOOKS INC.

What Is It?

What is the difference between a Zener Diode and an avalanche diode? Can they be used interchangeably?

W.N.—Moonachie, NJ

Technically, if a Zener diode breakdown voltage is above 8 volts, it should be called an avalanche diode. Differences are noted in the negative or positive temperature coefficient characteristics of the PN junction.

But 99.99 percent of the time, who cares??

Make a 7805 Yourself

Integrated circuits are nice for lazy builders; however, I'd like to build a 5-volt DC regulated circuit where I substitute discrete circuit parts for the circuit that is used in the 7805. What is your opinion

R.M.—Bothell, WA

My dad said that I should never ask a question that requested an opinion. You know what opinions are worth on the open market! As for you project, I suggest you go the entire route on this one by first going to the beach and picking up some sand from which you can purify rods of silicon, etc. One of the prime advantages of the voltage regulated IC, in fact any IC, is that it is cheaper to buy and install than the many parts that are packaged within it.

Stick with technology and develop new and useful applications from existing components.

A Short Question

What is "Noise Floor"

T.H.—Larchmont, NY

Actually, your question was not that short—I made it short to keep our readers guessing! When you talk about background noise, you often resort to the words "noise threshold." That is the noise that is always present and from which the

signal must rise over in order to be detected. Put all of this on the screen of a cathode-ray tube of a spectrum-analyzer, and you will see something that looks like grass at the bottom with some spikes pushing their way upward. The term grass defines the noise seen on the scope. Old radar operators referred to the noise as grass because the green phosphor gave it appearance of a grass lawn. Modern-day technicians call this the "floor" or "noise floor" because anything that occurs below it is lost. The spikes are those signals that are stronger than the noise and poke their outputs above the "noise floor." Gee, I like that kind of talk!

RS-232C Troubles

I interconnected two micros via their serial ports using ordinary ribbon cable and a black box. The micros "talk" to each other over short distances; but when the ribbon cable gets longer than 50 feet, strange things begin to happen. Characters are lost, verification takes several tries, and sometimes I never get to transmit the full file—that's during a good day. On bad days I'm sorry that I started the whole business! What is going wrong?

W.B.—Amherst, NH

The same problems occurred with the early transatlantic cables—capacitance per foot accumulated over long lengths so that code pulses were rounded off, blending to each other causing havoc at the receiving end. When a RS-232C signal changes from one condition to the other, the specification limits the amount of time in the undefined region to 4 percent of a bit period. This requirement determines the maximum amount of stray capacitance allowable in a cable, because the capacitance stretches the rise time of the signal. RS-232 specifies that the capacitance must not exceed 2500 pF. Since the

cables generally used for RS-232C have a capacitance of 40-to 50-pF per foot, RS 232C limits cables to 50 feet approximately. That distance is reduced by noise pickup from AC lines.

The capacitance of the ribbon cable increases when the ribbon cable is bunched, folded, or rolled, or placed next to a metal conduit or AC line. What to do? You could reduce the overall length of the cable and be more careful about the path taken by the cable, but I'm sure you have tried that. Try lowering the baud transmission rate. Nice things begin to happen as you reduce the data from 9600 bps (bits per second) to 300, or lower. The lower rates reduces the overall effect transmission-line capacity

Also, your signal ground may be poor by not having enough copper in it. Beef it up by adding several unused wires in the ribbon cable in parallel with the existing signal ground wire (pin 7).

Another options is to use current-loop technique for data transmission that is permitted and provided for in many I/O serial boards and defined in RS-232C. Beyond this advise, I propose using modems

Old but Still Useful

I am going to dump my 8-bit Z80 computer at a flea market as soon as I get my new PC, that is, provided you come up with a better idea. Can you?

—R.T., Boulder, WY

I'm writing this answer with an old 8-bit computer. The discs are set up so that they can boot up the system and include the program EDIT.COM on them. That's my word-processing typewriter that I won't give up for anyone. My 16-bit rig is reserved for games (I fool around also), Microsoft BASIC, spreadsheet, DBASE, and others goodies. The 8-bit word-processing beats any typewriter now on the market so why give it up!

Take Up To \$117⁷⁵ In Books (Limit 5 Books) for \$2⁹⁵



ELECTRONICS BOOK CLUB

Keep in Step With the Future . . . Become
a Part of the Fascinating World of Technology!

- High-Tech How-To
- Space Age Projects
- Digital Electronics
- Artificial Intelligence
- Computers/Robotics
- Telecommunications
- Ironclad No-Risk Guarantee

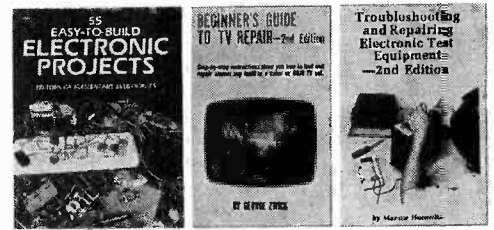

1999
List \$21.95

1013
List \$14.95

1663
List \$24.55

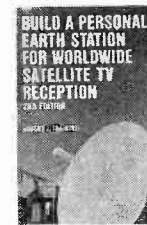

1909
List \$21.95

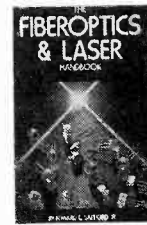

1671P
List \$16.95 (paper)



1465
List \$16.95



1984
List \$14.95



1211P
List \$12.95 (paper)



1793
List \$14.95



1693
List \$21.95



1199P
List \$14.95 (paper)



1553
List \$15.95

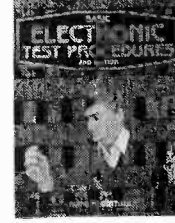

1927
List \$23.95



1625
List \$21.95



1825
List \$15.95

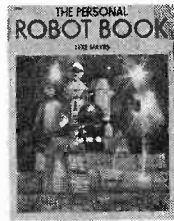

1896
List \$21.95



1925
List \$24.95



1719
List \$18.95



1632P
List \$12.95 (paper)



1758P
List \$10.95 (paper)



1650
List \$19.95



1593
List \$13.95

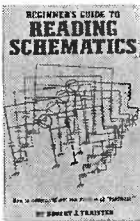

1536
List \$14.95

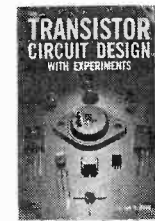

1875P
List \$14.95 (paper)



1474P
List \$12.95 (paper)



1996
List \$18.95



1183
List \$16.95



1870
List \$19.95

FREE
Handy, Pocket Sized
Resistor and Inductor
Color Code Calculator

ELECTRONICS BOOK CLUB

FREE When You Join Now →

7 very good reasons to join the Electronics Book Club

- **Big Savings.** Save 20% to 75% on books sure-to-increase your electronics know-how
- **No-Risk Guarantee.** All books returnable within 10 days without obligation
- **Club News Bulletins.** All about current selections—mains, alternates, extras—plus bonus offers. Comes 13 times a year with hundreds of up-to-the-minute titles to pick from
- **Automatic Order.** Do nothing and the Main selection will be shipped automatically! But . . . if you want an Alternate selection—or no books at all—we'll follow the instructions you give on the reply form provided with every News Bulletin
- **Bonus Books.** Immediately get Dividend Certificates with every book purchased and qualify for big discounts of 60% to 80%
- **Extra Bonuses.** Take advantage of added-value promotions, plus special discounts
- **Exceptional Quality.** All books are first-rate publisher's editions selected by our Editorial Board and filled with useful, up-to-the-minute information

© 1986 Electronics Book Club



ELECTRONICS BOOK CLUB

P.O. Box 10,
Blue Ridge Summit, PA 17214

Please accept my membership in the Electronics Book Club and send the 5 volumes circled below, plus my FREE Resistor and Inductor Color Code Calculator, billing me only \$2.95 plus shipping and handling charges. If not satisfied, I may return the books within ten days without obligation and have my membership canceled. I agree to purchase 4 or more books at regular Club Prices. (plus shipping/handling) during the next 12 months, and may resign any time thereafter.

1013 1183 1199P 1211P 1465 1474P 1536 1553 1593
1625 1632P 1650 1663 1671P 1693 1719 1758P 1793 1825
1870 1875P 1896 1909 1925 1927 1984 1996 1999

Name _____
Address _____
City _____
State _____ Zip _____ Phone _____

Valid for new members only. Foreign applicants will receive ordering instructions. Canada must remit in U.S. currency. This order subject to acceptance by the Electronics Book Club

CEHB-586

NEW

PRODUCTS PARADE

New Solar Radio

No Batteries Required.
Never Requires Maintenance.
Lightweight.
Excellent Stereo Sound.

Introducing! The newest in **solar radio**. This stylish radio visor cap is the newest in portable radios. The **solar radio** allows you to leave your hands free while listening to your favorite station. The solar visor is also equipped with headphones for private listening pleasure.

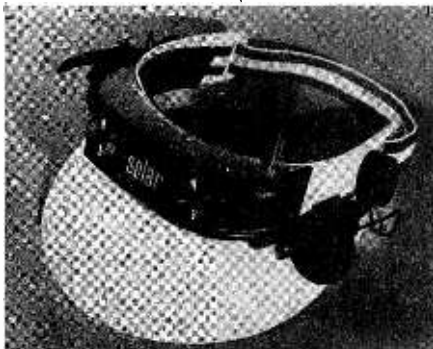

The solar cells never wear out or require maintenance. The solar energy comes directly from the sun or ordinary indoor lighting. This novelty item is great for sporting events, skiing, jogging, golfing, the beach, traveling, and at home. Outstanding gift item for any occasion.

Satisfaction guaranteed or full refund. Available in AM or FM models. (please specify correct model). Send check, or money order for \$16.00 & \$2.50 postage and handling. Order 2 (\$30.00 & \$2.50). HopeWell Enterprises, Dept-A, P.O. Box 69135, St. Louis, MO. 63169.

NEW SURGE SUPPRESSOR

GTE introduces a new SMOOTHLINE power surge suppressor designed to protect personal computers, telecommunications, video and other electronic equipment from voltage surges.

Produced by the Control Devices Operation of the GTE Special

Products Division, the CP-220 SMOOTHLINE power surge suppressor is designed to serve the needs of personal computer (PC) users. The unit's four outlet design permits the operators of PCs to protect the devices' peripheral equipment from power fluctuations which could result in loss of data or damage to the equipment. The power suppressor is equipped with an exterior operating switch which glows thus assuring the user that the unit is operational.

The low-cost CP-220 SMOOTHLINE uses advanced and proven GTE surge suppression technology, originally introduced in the recently announced two-outlet CP-211 surge suppressor which, provides protection normally found in high priced commercial power protectors. The suggested retail price of the SMOOTHLINE is \$69.95, complete with a two-year manufacturer's warranty.

The CP-220 has a clamping time of less than one nanosecond after surge detection and can withstand surges up to six kilovolts. A noise suppression filter network protects

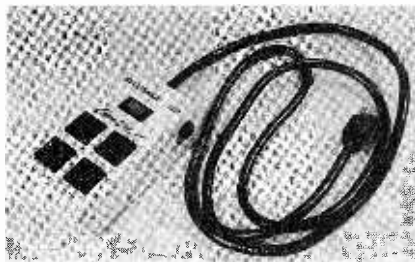

against data corruption and equipment malfunction due to electromagnetic interference or radio frequency interference (EMI-RFI) from fluorescent lighting and other common sources. A built-in 15A circuit breaker provides added protection from high or extended surge currents.

For additional information call (207) 642-4535 or write to Michael L. Lyons, GTE Control Devices Operation, Route #35, Standish, ME 04084.

CHANNELPLUS INTRODUCES "A" SERIES VIDEO MULTIPLEXERS

"Studio Quality" Performance
Cited For Multiple TV Distribution System

Multiplex Technology, Inc., has announced a new "A-Series" line of ChannelPlus™ video multiplexers that provide broadcast studio quali-

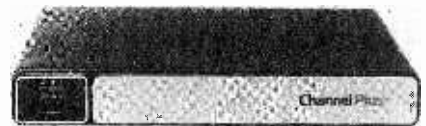

ty pictures to any number of connected TV receivers. ChannelPlus units accept multiple incoming video signals from VCRs, satellite receivers, pay TV boxes or other sources, and rebroadcast the signals on unused UHF channels. All TVs linked on a common antenna or cable can then receive any of the sources merely by tuning to the appropriate channel.

According to Philip Strauss, Multiplex Technology President, "This new series makes professional quality video distribution available to everyone. The convenience and versatility of the ChannelPlus concept has been accepted as the most effective way to connect more than one TV to a video source. With the 'A-Series,' a truly superior picture is made possible through the high resolution, frequency adjustable, modulators built into the unit."

The benefits of using a video multiplexer are that the user can change video sources by just changing channels. Any person at any TV can watch all video sources. A VCR can record automatically any other video source in the home by programming up the assigned channel just as would be done had the source come through the air. Remote control TVs can change sources by simply changing channels. There is no limit to the number of TVs that can be interconnected

and there is no limit to the number of video sources. In addition, there are no switches.

The ChannelPlus unit consists of a series of miniaturized television transmitters, each of which can be set to transmit on any channel number in the UHF spectrum that the user chooses. Normally the user selects channel numbers that are not being used by over-the-air stations. The transmitters broadcast the output of whatever source is connected to them. These broadcasts are combined onto the existing antenna wiring or cable wiring for distribution throughout the home.

ChannelPlus is housed in a compact case only 1.5" high by 10.75" wide by 7.0" deep. Connectors are provided on the rear to accept standard RCA type plugs or, optionally, RF type plugs. A "cable-ready" version is another option. Units are available in one—or two-channel versions with prices beginning at \$149.95.

Multiplex Technology, Inc., is a leading innovator in the design and development of electronic multiplexing devices for networking applications. The company manufactures and markets from its headquarters located at 251 Imperial Highway, Fullerton, CA 92635. Telephone is (714) 680-5848.

MODEL S-1 DESOLDERING TOOL

Sibex, Inc. announces the release of its Model S-1 Desoldering Tool. This device is designed for the engineer or technician who performs electronic repair work or modification.

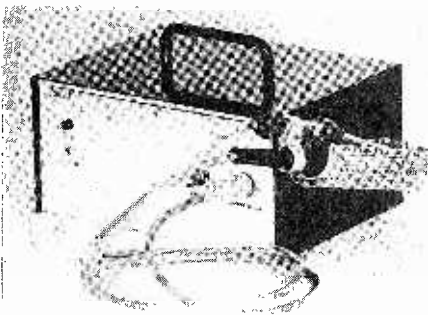

This "low-priced desoldering tool with the high-priced features" incorporates a silent, electrically powered vacuum pump controlled by a switch conveniently located in the handpiece. The unit is easily

cleaned while in use. Designed for static-free operation, it is ideally suited for PC board repair work.

The Model S-1 Desoldering Tool is competitively priced at \$189.95 with delivery from stock. For more information, write or call SIBEX INC., 3320 U.S. 19 North, Suite #410, Clearwater, FL 33519 (813) 786-3001.

CIRCUIT BOARD REPAIR KIT

APE Model SRS 020 miniature drilling system provides for all drilling, grinding and polishing of PCB'S during repair operations.



Model SRS 020 includes a variable regulated power supply and features a precision miniature hand held drill, with an infinitely adjustable 3/16", 3 jaw chuck. A full complement of bits, burs and abrasives is also included. Model SRS 020 is packaged in a durable high impact plastic carry case and is priced at \$139.00. For additional information contact: Automated Production Equipment Corp. 142 Peconic Ave. Medford, New York 11763 (516) 654-1197.

AUTORANGING DIGITAL CAPACITANCE METER

MC 300 is a battery-powered, completely autoranging capacitance meter. This unit also identifies transistors (NPN, PNP), their leads (E, B, C), tests zener diodes and rectifiers up to 24V and calculates cable length.

Full 4 digit 0.5 inch LCD display autoranging with 10 range manual capability. Ten capacitance ranges form 000.1pF to 999.9mF, true capacitance, leakage, time constant, dielectric absorption, zeroing and sorting features. Hold function freezes display values during 7 test modes. Diode clamping and fuse protected inputs at both input sockets and banana jacks.

Hi-impact ABS case with metal tilt

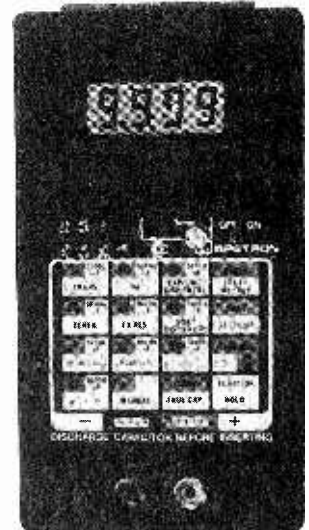

stand. Dimensions 7"×4"×1.75". Carrying case, AC battery adapter, and co-axial test cable available. The finest value in the market today at \$179.95. Pilot Marketing, P.O. Box 44, Grand Island, NY 14072 (716) 773-9411.

ADD A TERMINAL

TermCon has a new product that offers a simple solution to an old problem. The Roundtapper Kit makes it possible to add a circuit to those fuse panels using round AGC type fuses. Just slip the Roundtapper over the end of the AGC type fuse and pop both the fuse and the Roundtapper into the fuse block. The device won't fall out and in fact requires a strong positive pull to remove it. It is made of high quality brass.

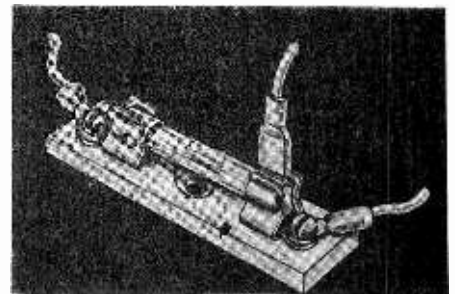

When installed, a 1/4-inch tab will protrude above the fuseblock. Onto this tab place the fully insulated female pushon terminal furnished with the kit. Installation takes less than a minute and its the way to pick up power for radios, stereos, alarm systems, horn sounding devices and all electrical accessories. Roundtapper Kits sell for \$36.00 per hundred and are available from TermCon Inc. at 3224 Mayfair Blv., Fresno CA 937703-3181. ■

NEW

BOOK REVIEWS

MICRO HISTORY

FIRE IN THE VALLEY

Frieburger & Swaine
Osborne/McGraw-Hill, 1984
181 pages, \$9.95

This book traces the history of the personal computer starting with 13-year old Bill Gates and 15-year old Paul Allen who began in the late Sixties to get into micro software, becoming the founders of today's multi-million dollar software giant Microsoft Corp. It includes Charles Babbage's Analytical Engine and Herman Hollerith's Tabulating Machine (developed to help in the first US Census) which survives today in the 80-column "IBM card" (Do not fold, spindle or mutilate).

Most interesting to this reader (and most who read the monthly *Computers and Electronics*) is the account of "Uncle Sol"—Les Solomon, Technical Editor of that magazine—and his "boys" who pioneered microcomputers from their attic and basement shops to found today's micro industry. From them came Altair, which begat Apple, which begat...and so on.

Written amusingly, with idealism in the authors' eyes, it's for non-engineers and non-technicians, as well as those who do know an electron from a Kilobyte. Anyone interested in where micros came from and how (non-technically speaking) they got the way they are, will be, as I was, fascinated by this still very-much evolving story.

THE ELEMENTARY COMMODORE 64

William Saunders 1984
Datamost Inc. Chatsworth, CA
233 pages, softcover \$14.95

Although the Commodore 64 is one of the best buys around in micros, its instructional manual is not as good as one might wish. Hence a lot of books have been written about learning about this micro. The Elementary Commodore 64 is one of the best books on the subject. The author writes for the beginner of course, and present information easily assimilated on how to use

BASIC with this micro. The book has 10 Chapters. He starts off discussing the hardware (the machine) and the software (programs). He also discusses printers and monitors in detail and tells how to connect each to the micro.

He discusses using cassette tape as well as the more-expensive method of using a disc drive. Since Commodore BASIC is different from other BASICS, he teaches you that BASIC as you go along. After you've finished the first four chapters you should be able to write simple programs of your own. These include commands such as Goto, Gosub, For...Next, and so on. Other Chapters deal with formatting text and strings, and sound and sprites. He ends each Chapter with a summary which is good for reviewing whether or not you've understood each point.

In the final Chapter the author provides extra information to let you take advantage of the full power of the 64 micro. An excellent introduction for those owning, or planning to own, a Commodore 64, or the more recent (and to me much better, since it's all-in-one) model 64 SX, their new portable micro.

GETTING STARTED IN ELECTRONICS

Forest Mims, III
Radio Shack, Div. Tandy Corp.
129 8 1/2 x 11 pages, \$2.49

ENGINEER'S NOTEBOOK, VOLS. I AND II

same author, publisher, price
and pages

"Welcome to the world of electronics, one of the fastest-growing of today's 'high-tech' fields, and an educational and entertaining hobby. This book takes you from static electricity and lightning to solid-state electronics. Along the way (covering) electricity, electronic components, and integrated circuits (ICs). Chapters 3-7 show how components and ICs form electronic circuits. Chapter 9 gives plans for 100 circuits, each of which (the author) has built and tested...This book can give students a basic knowledge of electronics."

This introduction to the first book is entirely accurate. Mims, one of the easiest-to-read and most authoritative writers on the subject today has written the book in semi-handwritten (block printing) style making it extra appealing to beginners as well as to his veteran electronics technician.

Sprinkled profusely with humorous yet accurate cartoons showing components doing what the text discusses, the book is easy and fascinating to follow, yet technically sound. An absolute must for anyone interested in an informal entry to learning electronics.

The second and third books (slightly, but forgivably misnamed), now in Volumes I and Vol. II, carry the student further, are less entertaining, but even more meaty. For actual hand-on experiments with ICs, though much can be learned by simply reading the information-packed pages.

Anyone sincerely interested in learning how electronics works and how they work our machines, up to and including micros, might start here.

WILLWRITER... WRITES YOUR WILL

WillWriter, a new book/computer software package from self-help legal publisher Nolo Press, helps computer users write simple, legally-binding personal wills. The \$39.95 software runs in IBM PC and compatible computers such as the Apple II+/c/e, Macintosh or Commodore 64/128 personal computers.

WillWriter was developed as a practical and inexpensive way for personal computer users to avoid becoming part of the 66 percent of adult Americans who die each year without leaving a will. The simple-to-use book and software package were designed to overcome many of the standard excuses for not writing a will: "I don't have time to visit a lawyer; it's too expensive; I don't have enough possessions to dispose of to worry about a will."

The 170-page book clearly and completely explains the legal con-

cepts and conditions involved in making a will. The book also provides information on important aspects of estate planning including trusts and probate avoidance methods. Nolo stresses that people with very complex estates or distribution requirements seek the services of a competent attorney.

The software leads the user step by step through each section of the will. On-screen help, prompts and fill-in-the-blank questions make writing a will a simple and painless procedure.

WillWriter allows users to quickly change and update their wills, avoiding the expense and hassle of visiting a law office. The software is provided on a single non copy-protected disk. Nolo has a 30-day, money-back refund policy. The company will inform WillWriter buyers of any significant changes in the law, and also enhancements to the program for a period of time.

WillWriter is available at many book and computer stores, or postpaid directly from Nolo Press, 950 Parker Street, Berkeley, CA 94710, or telephone (415) 549-1976. Price: \$39.95, Pages: 170, Illustrated, with floppy disk.

99 FUN PROJECTS

Here's a truly unique project-book—*99 Fun-to-Make Electronics Projects*, by Cy Tymony—that highlights the fun side of electronics. The text shows you how to make all kinds of fascinating



jewelry, home and auto accessories, gadgets, and even clothes that display the wizardry of electronics via flashing lights and sound effects! Written for the novice experimenter, but it includes plenty of sophisticated gadgetry to appeal to more experienced hobbyists, too! Best of all, you can put any of these exciting projects together in a

single evening using LEDs, batteries, and a few ICs. And, you're sure to be the center of attention when you show off your electronics creations...and probably swamped with requests to make copies for your friends. These gadgets and gizmos make terrific and inexpensive gifts... especially for the disco set!

You'll discover a whole new world of wild and way-out electronics applications and lots of practical ones as well. Build an LED space gun with sound effects, a musical door ajar indicator, disco cufflinks, an automatic auto glove box, and much, much more! Each project is unique, can be made with just a few inexpensive parts in just a few easy steps.

To get you in the swing of things, the book starts out with a section on the devices and procedures you'll be using plus all the data you'll need to finish any project given, and do it right the first time! Circuits, switches, lead wires, batteries, resistors, solar cells, LEDs are all thoroughly examined. Plus, there are details on electronics tools like the 555 timer IC and other devices utilizing the newest miniaturized components, then it's on to making lots of electronic things to wear—a multi-color light T-shirt, bracelets, belts, hair clips, eyeglasses...even shoes, pants and jackets! You'll find LED bead curtains and an IC-controlled wall design/light show and other fun things for your home. There are auto accessories, too—a flashing LED hood ornament, a disco dashboard, and more!

Step-by-step instructions and plenty of illustrations, diagrams, and schematics guide you as you make one of the 99 exciting projects in this sure-to-interest project book designed for the NOW generation!—Published by Tab Books Inc., Blue Ridge Summit, Pa. 17214; \$8.95.

Jobs of the Future

Marvin Cetron, 1984
258 pages, paper, \$6.95
McGraw-Hill

Subtitled "The 500 Best Jobs—Where They'll Be and How to Get Them," this compendium of today's high-tech job prospects is a good

book for people who've not yet made a final career/education decision, or who are considering a career change in the Eighties or early Nineties.

Although *Jobs of the Future* covers employment prospects in all fields in the next 20 years, it concentrates on high-tech industries, particularly those in electronics, computers and robotics. Cetron is head of a firm near Washington, DC, specializing in forecasting job trends and he's drawn on his company's data bank to fill this book with statistics and trend descriptions.

A brief but valuable four-page section (the last four of Chapter 8, "How To Get and Keep A Job,") details the job search/resume/interview, those three important steps so many people fail to organize properly. In other sections he instructs, "Learn to read and write (typewrite) effectively," and "Learn to communicate simply." And finally, he admonishes (as do I) "Learn computer literacy" (how to use them, not how to program them). Amen.

120 pages, Appendix A, *Occupational Profiles*, is filled with a 22-column data bank of job profiles: work site (office, factory, home,



etc), number of workers required by 1990, salaries (entry and mid-career), educational requirement/training, and growth categories. It appears these 120 pages are a printout (not edited enough, if at all) of his firm's files, for it includes, in addition to such promising categories as CAD (Computer-Aided-Design) Software Specialists, CAD Clerks, CAD Technicians, and CAD Draftsmen (his estimate of three million seems high), such unusual job categories as dancers, comedians, and exotic boutique owners. ■

APE SHOOTER

Get more from your computer joysticks!

By Larry Burks

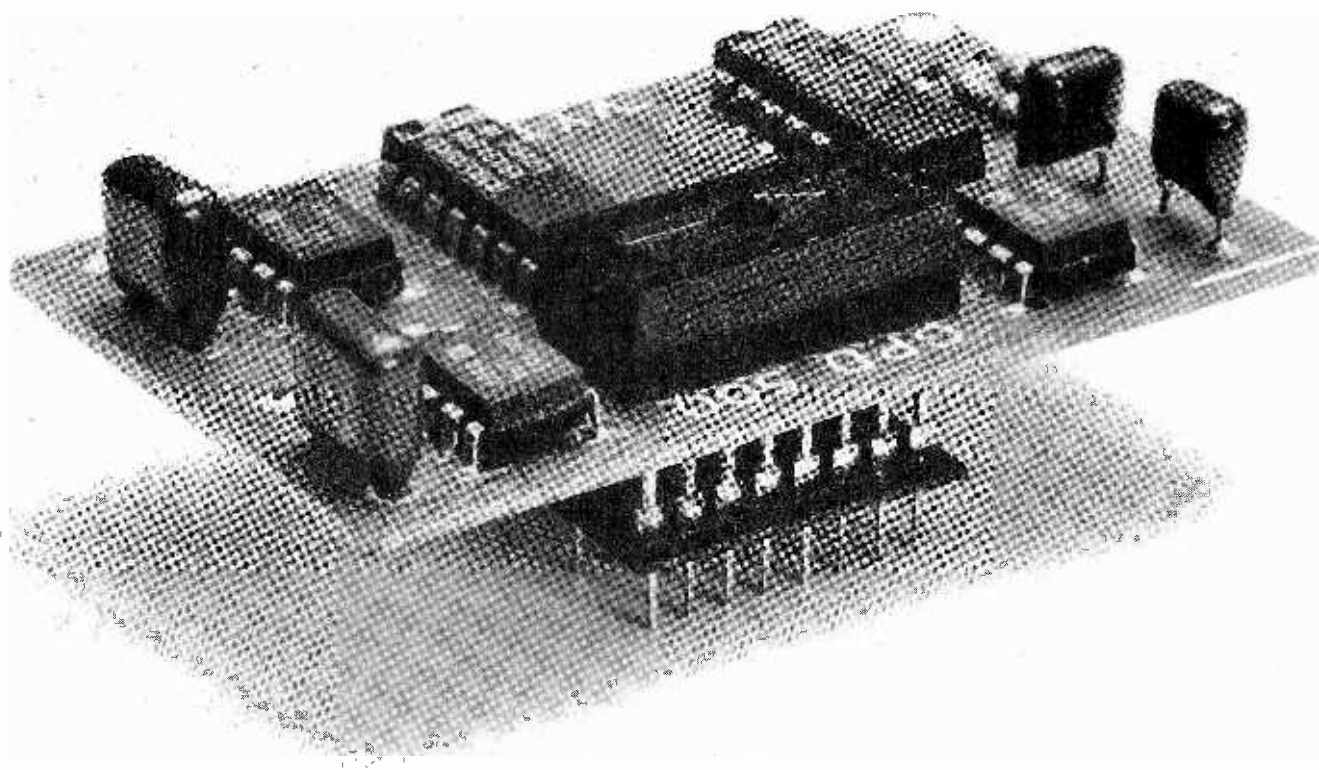

When Apple Computer initially released its product line to the marketplace in the late 1970's, its phenomenal success spawned the development of many new companies. Needless to say, the ability to play arcade-style games on such machines certainly did much to popularize the personal computer during those years. Arcade games became so popular in fact, that doctors had to coin new terms to describe the ailments to wrists and thumbs serious players were developing. It became obvious that some method of relaxing the hand muscles during play could be of benefit.

Ape Shooter is an inexpensive device designed to help reduce hand fatigue and discomfort. It does this by adding auto-repeat to your joysticks. When installed, the paddles and fire buttons function normally. However, if the user holds the fire button down for $\frac{1}{2}$ second or longer the paddle output begins to pulse 30 times per second. Best of all, it works

independently on either paddle and with all standard joysticks.

As shown here, Ape Shooter was designed for the Apple II+, Apple IIe and work-a-like computers. It can be interfaced to other computers by using appropriate connectors. Total construction cost is approximately \$10 to \$15 depending on your choice of fabrication methods. Ape Shooter will definitely help you reach new and higher scores.

About the Circuit

Ape Shooter appears schematically in Fig. 1. When either paddle button is depressed and releases the output of exclusive OR gate, IC4 generates a momentary pulse. The computer input interprets this as a normal switch closure and outputs a single shot.

Fig. 1. The Ape Shooter schematic diagram is simpler than you would expect! Only five integrated-circuit chips are used.

APE SHOOTER

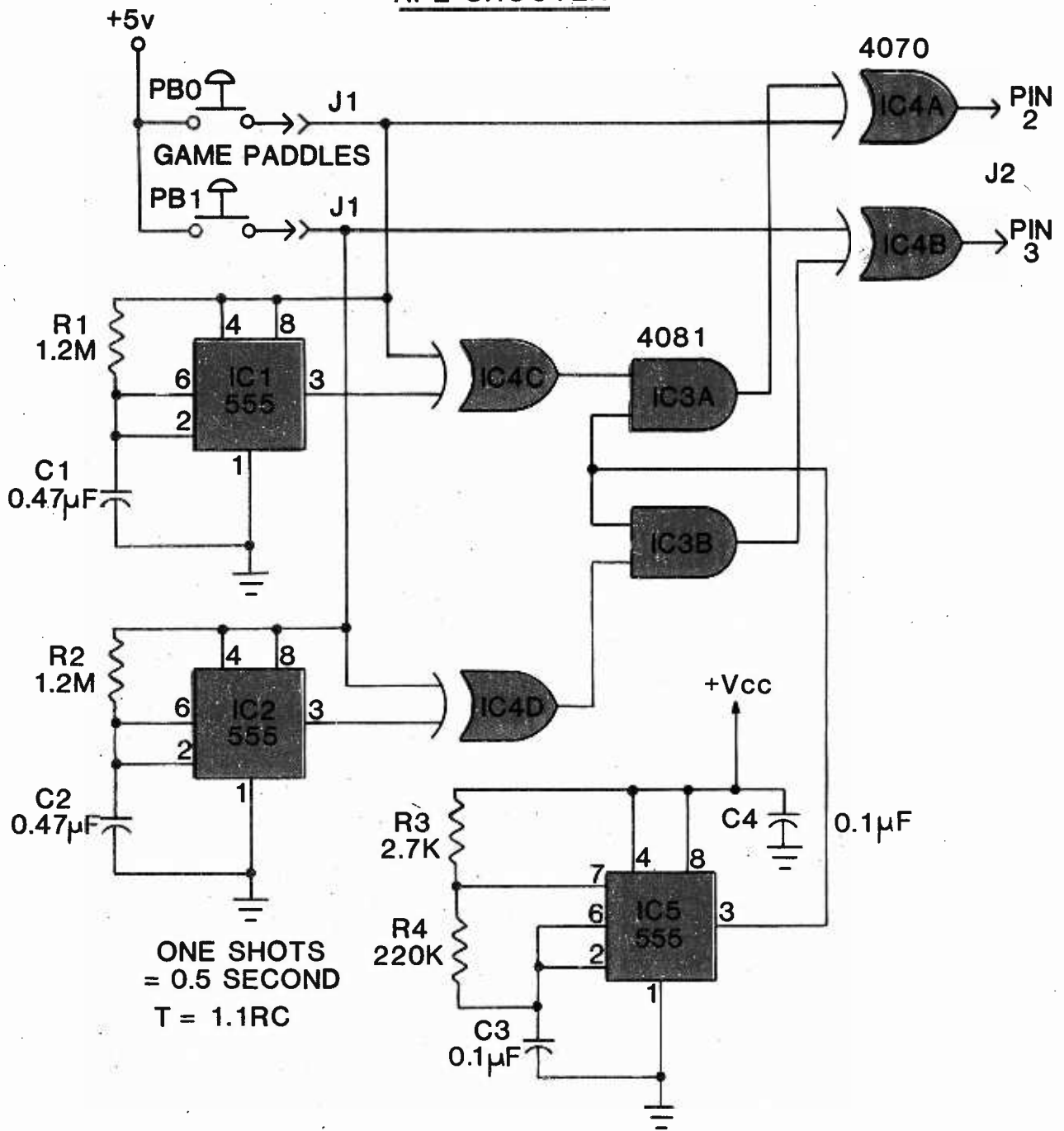

ONE SHOTS
= 0.5 SECOND
 $T = 1.1RC$

OSCILLATOR = 30 HERTZ

$$F_o = \frac{1.44}{(R_3 + 2R_4) C}$$

FIGURE 1

PARTS LIST FOR APE SHOOTER

- | | |
|--|--|
| <p>C1, C2— .047-µF, 15-WVDC, metalized-film capacitor
 C3, C4— 0.1-µF, 15-WVDC, metalized-film capacitor
 IC1, IC2, IC5— Low-power CMOS 555 timer integrated-circuit chip (Intersil ICM7555 or equiv.)
 IC4— 4070 quad 2-input Exclusive-OR gate integrated-circuit chip
 IC3— 4081 quad 2-input AND gate integrated-circuit chip</p> | <p>J1— 16-pin, single-level, wirewrap socket (see text)
 J2— 16-pin DIP-header socket
 (Resistors are ¼ watt, 5% carbon-film resistors)
 R1, R2— 1.2 Megohm resistor
 R3— 2700-ohm resistor
 R4— 220,000-ohm resistor
 Misc.— Printed-circuit board, IC sockets or Molex soldercons, stranded insulated wire, solder, etc.</p> |
|--|--|

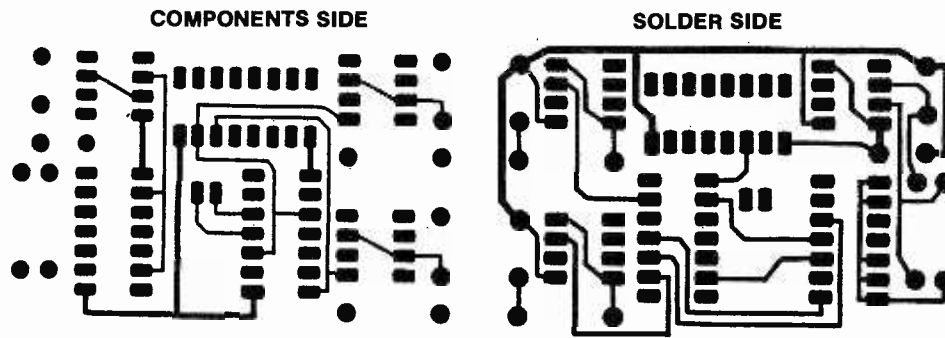

Fig. 2. The component and foil sides of the printed-circuit board are shown here same size. It is important that both sides align on the board so that drilled holes are centered on the correct solder pads on both sides of the board.

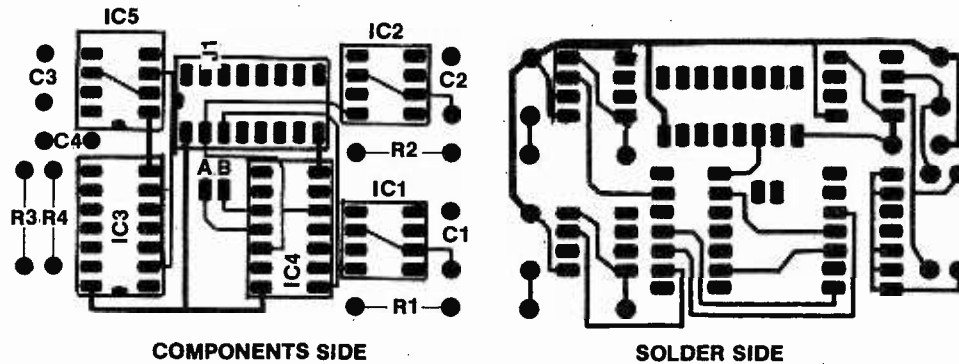

Fig. 3. This diagram locates the components that are mounted on the printed circuit board.

IC1 and its associated passive components are wide as a power-up one shot. Power is applied to the circuit only when PBO is closed and its output immediately goes high. With a high at both inputs to IC4C its output remains low. As long as the power is present to IC1 capacitor C1 begins to charge through R1. When the threshold voltage at pin 6 of IC1 reaches $2/3$ of V_{cc} (about $1/2$ second) the output at pin 3 goes low.

The components connected to IC5 configure it into an astable multi-vibrator (oscillator) with an output frequency of 30 Hertz. Its output is fed to both IC3A and IC3B. These two input AND gates act like switches. They allow the oscillator signal to pass only when a logic 1 is present at the other input. That is provided by the output of IC4C which is high $1/2$ second after a push button is depressed. Thus the device generates a single shot, or after the proper delay, a train of pulses. IC2 operates in an identical manner to IC1.

The time delay before automatic pulsing begins may be adjusted to suit user preference. Increasing or decreasing C1 will provide a longer or shorter delay respectively. One important not should be mentioned here. The rate of oscillator IC5 can be varied by changing the values of C3 and R4.

Ape Shooter usually generates pulses much faster than most programs can expect them. This is true because a certain amount of program code must be executed between an input and its final output.

Therefore, increasing the oscillator's frequency will most likely fail to increase the speed of action on the computer's screen. But, if in doubt experiment by substituting some different values and see what happens. After all, that's what experimenting in electronics is all about.

Construction

Since the circuit layout is not critical, any convenient board-type method of assembly such as wirewrap, point-to-point on perforated board or printed-circuit board can be used. An actual size etching and drilling guide for a double sided PC board is shown in Fig. 2. Note that the circuit can be constructed on a single-sided PC board. Because the circuit was an experiment it was decided to try a more sophisticated method of construction. Also, the small size of the project makes registration of the artwork on both fairly easy. In either case IC sockets are optional, but recommended.

Mount the resistors capacitors and IC's (or their sockets) as shown in the component placement guide in Fig. 3. Care should be taken when handling the IC's since they are static-sensitive devices. Use a small wattage grounded-tip iron and avoid unnecessary handling of the IC's. Don't forget that if you fabricate your own circuit board you must solder components to the solder pads on both sides of the circuit board unless you have plated through holes. If you use

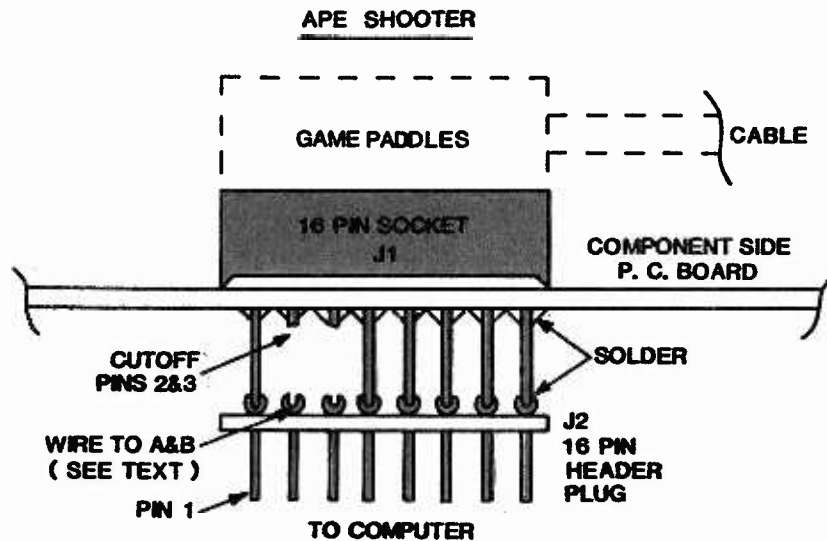

Fig. 4. Here are the adaptor plug assembly details that are described in text.

sockets it will be necessary to leave them slightly raised above the PC board so they may be soldered. An alternative is to use Molex soldercons to make installation easier. A commercial PC board is available along with a complete kit of parts including sockets.

The details of the adaptor plug are shown in Fig. 4. It is best if you use a single level wire wrap socket for J1. If you have difficulty finding one, just trim off the pins to about 3/8 inch in length. That prevents that adaptor plug from becoming too long and unstable. After soldering J1 into place, cut off pins 2 and 3 flush with the PC board. Solder a short length of insulated wire to pins 2 and 3 of the dip header plug J2. Next, carefully solder J2 to J1 making sure the pins with the insulated wire are oriented toward the solder pads marked A & B. Finally, connect the wire from pins 2 & 3 to pads A & B respectively and solder. That completes the assembly of the project. Remove any flux residue with a stiff brush and isopropyl alcohol or any commercial solder flux remover, and the board is ready to be installed.

Installation and Use

Be sure to turn off the computer before starting installation. Remove the top cover, and, if installed unplug your game paddles. Carefully insert the 16-pin adaptor plug into the game socket. Be sure to orient the device so that pin 1 matches the game port. Consult the Apple reference manual for printout information if necessary. Failure to observe these precautions may result in damage to the computer. Plug the game

paddle cable into Ape Shooter and the installation is complete.

Replace the cover and turn on the computer. You should see the standard message. If there is any unusual behavior, i.e., humming, no output, no beep, etc., turn off the power. Recheck the installation steps and try again. If there are still problem symptoms, remove Ape Shooter and power up the computer. This will help to determine which unit is malfunctioning. If the computer works correctly, recheck all wiring connections, solder joints, and component orientations and try again.

Momentarily pushing a fire button causes a single shot as normally expected. If however, the button is held down for longer than 1/2 second, the device will begin to pulse 30-times per second. This effect works independently with either paddle button so it may be used with two-player games. I hope you enjoy building and using the project as much as I have. Good luck and good shooting. ■

Note: The following are available from Vytron, P.O. Box 7019, Altamonte, CA 91802 (618-289-8936). Complete Ape Shooter Kit (GPD-500) AT \$13.95 PLUS \$2.00 for postage and handling. Also available separately (GPD-PC) etched, drilled, and plated through double-sided circuit board at \$3.95 plus \$1.50 for postage and handling. California residents, please add sales tax. And \$5.00 handling charge for foreign customers.

ELECTRONICS TRAINING THE KEY TO YOUR FUTURE

By Don Jensen

You've seen the advertisements many times, and you'll see them again. "Where is your electronics career headed?" asks one. "Expand your career horizons," coaxes another. "Train for the jobs in the fastest growing career field," urges a third.

These advertisements by a half dozen or so home-study schools across the nation say approximately the same thing.

There are new jobs, new opportunities, new challenges out there in the field of electronics for the man or woman who has the education, the training, the skills. It's the old American Dream, success is just over the next hill.

And the numbers are both real and big enough to make your mouth water. Worldwide electronics equipment sales should total more than \$100-billion. Sales of video cassettes alone increased over 83% in a single year. More than 11-million colors TVs are sold annually. Digital processing of signals, now video as well as audio, will add to the boom. Computers! Robotics!

Classroom education, unfortunately, isn't for everyone. Time and money are the stumbling blocks for many who would seek advanced electronic training. You may be employed full time now. Somehow you must squeeze in your schooling without sacrificing current income.

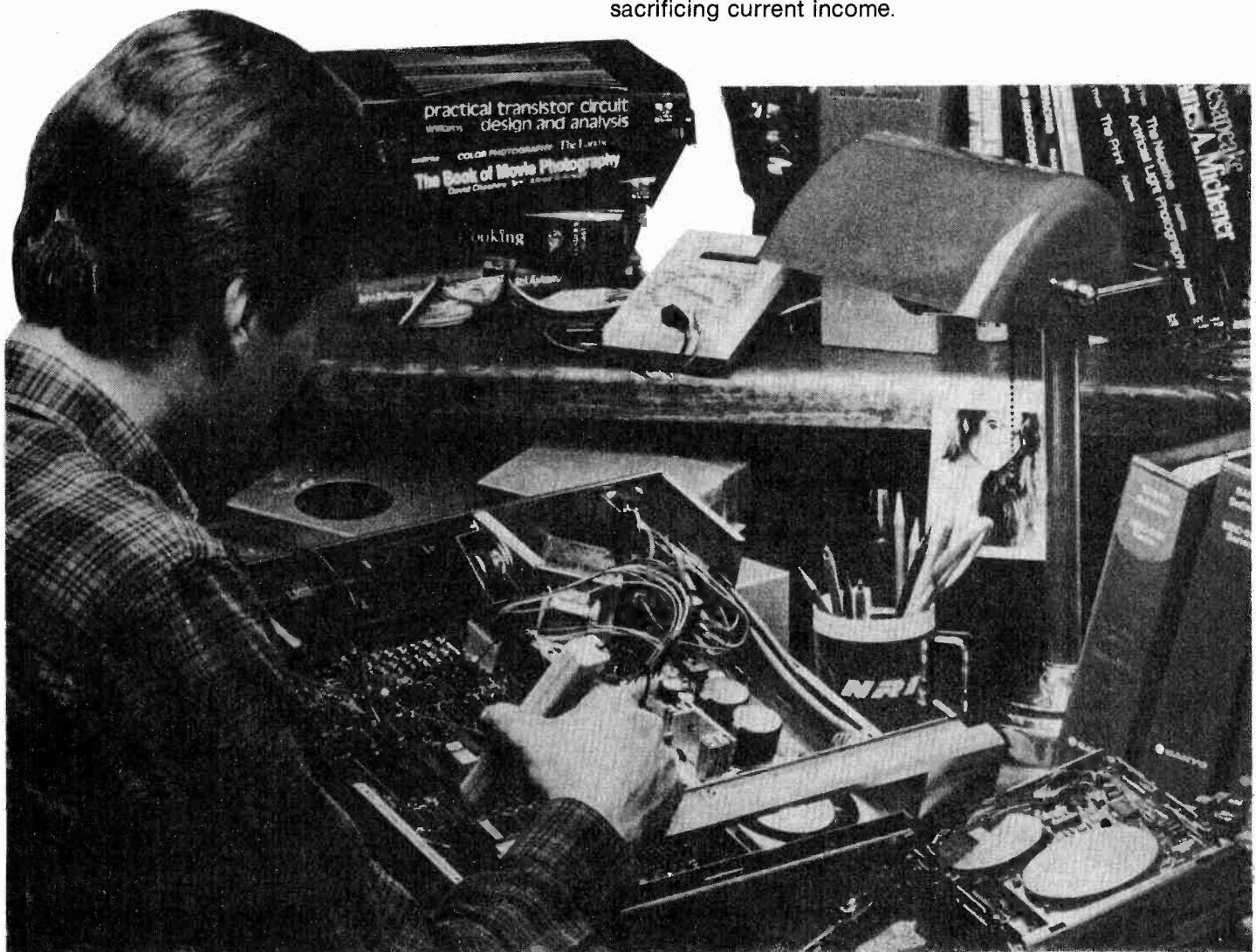

Home-study Electronics May Be For You. Every year, more than 3-million people study by correspondence. The average home study student is over 35, works full time and is a high-school graduate. However, for many of the courses offered, a high-school diploma is not a requirement.

A 1982 survey of correspondence-course training by the Navy Personnel Research and Development Center says that home study can run 10% to 25% of the cost of residential on-campus schooling.

Every major study of the subject since the 1930's shows that correspondence school students achieve and perform at least as well as those who studied the same subject in a campus setting.

The U.S. military recognizes the effectiveness of correspondence training, as do several hundred of the nation's largest companies. Franklin D. Roosevelt, Walter Cronkite, and Senator Barry Goldwater are among the well-known Americans who studied by mail.

You may be tempted to take the big step and sign up for the course that could take you from your dull, drab, low-paying, future-less job into tomorrow.

But correspondence courses offer no shortcut to learning! If you aren't ready to apply yourself, aren't willing to work hard to improve your knowledge and skills, save your money! The schools stand ready to help, but you're the guy or gal who has to do the work! But if you pick the right course for the right reasons, you may truly be on the way to the sort of career the school ads offer.

Pick a field on Position. For what types of jobs will your do-it-at-home school prepare you? Basic electronics courses will equip you to be an electronics inspector, tester, assembler or operator, sales or technical representative, or Junior technician. Advanced programs can prepare you for various repair or troubleshooting jobs; control, instrumentation, computer or robotics technologist, or engineering aide positions—to name a few.

If you press on to obtain your two-year associate degree your job opportunities could include electronics communication, research, or laboratory technician.

There is not pat answer to the question: "Which school is best?" Every prospective student has different personal goals, different scholastic needs, so each must decide for himself or herself which training will meet those needs and goals at the least possible cost. We urge you to write for the fascinating promotional brochures the various correspondence schools are eager to send you.

Learn By Building. A few years ago, most of the correspondence school advertisements stressed the electronic kits you would build during your training. The glamour item featured prominently in the ads then was a color television set you would construct.

Several home-study schools still heavily promote this sort of hands-on kit assembly, although the "temper" these days is a yours-to-keep personal computer or robot, rather than a TV.

If you want the most for your educational buck, though, look beyond the kits you will build. Do your best to find out from the promotional literature just how thoroughly the kit building is integrated with the

teaching of electronic theory and/or practical troubleshooting.

Kit assembly and electronic experimentation can be an important part of a good training program, but kit-building cannot substitute for basic book learning.

And, in fact, even those schools whose advertisements heavily promote the fact that students will learn by wiring their own computer, require heavy doses of electronic theory as well.

With many of the home study programs you will build various pieces of test equipment which you will use during your course of study and, probably in your post-graduation employment.

Some correspondence programs can lead to junior-college level associate degrees. They may involve some brief on-campus lab work, either at the school's own resident facility or a co-operating college. Only one correspondence school offers a baccalaureate, a bachelor of electronics engineering technology degree. However, 25 transferable credits must be earned in certain academic subjects such as English, history, chemistry, social and physical sciences at an accredited university near your home.

Of course, all the home study schools offer shorter courses leading to certificates and diplomas in a wide range of electronic sub-categories.

Let's Talk About Bucks. How much will your training cost? You can pay as little as about \$250 for a short, basic electronics course. Earning your degree by correspondence can cost up to \$5,000 to \$6,000. Many specialized diploma programs cost in the \$1,500 to \$3,000 range.

These are approximate costs for advance cash payment at the time of enrollment. If you opt for time payments, find out how much extra you will pay, in both actual dollars and the true annual interest rate. This will permit you to realistically compare the installment plan offerings of the different schools.

A check of time payment interest rates shows they vary rather widely, from school to school, from course to course. Some of the rates are attractive: 6 to 8½ percent, but one relatively low-cost course carries a 28¼ percent interest rate if you opt for monthly payments.

You probably will be required to keep up regular monthly payments even if you fall behind in your studies. So don't count on slowing down your study program just to avoid putting off a monthly payment when you happen to be financially strapped.

Federal Loans. Students in accredited correspondence programs are eligible for the federal Guaranteed Student Loan Program (GSL). You may, according to your needs, borrow up to \$2,500 to help pay for your tuition, with the federal government guaranteeing the 8-percent, long-term loan. Repayment begins six months after you graduate or quit the program, whichever comes first. You can pay back as little as \$50 a month, but, of course, if you make larger payments, the amount of interest you pay decreases.

Some schools offer helpful assistance to students wishing to apply for government loans. But one correspondence school indicates that philosophically it does not believe in government financial assistance and does not participate in loan and grant programs, even though it appears that it is eligible to do so.

Federal Assistance Veterans' Administration Educational Benefits (VEAB) are of lesser importance these days because the eligible veteran population has dwindled in recent years. A spokesman for one school says only 12 percent of its annual enrollment is making any uses of GI Bill funding. The VA today only refunds 55 percents of the cost of correspondence tuition. If you have GI benefits, contact your VA office for specifics before you enroll in a home-study program.

Depending on the complexity of the course, you will be expected to complete it within a reasonable period of time. That could be about a year for one phase of a longer course to a maximum of 6 years for some associate-degree programs.

But the best laid plans can go awry. You may never finish your course. Or you may decide to drop out after you've begun.

What About Performance? Each of the schools has a clearly set forth termination and refund schedule. Know in advance what it will cost you to drop out of your training program at any point along the way. These vary from school to school, but basically they are similar.

If you drop out shortly after enrolling—5 to 10 days, typically—you will get a full refund. After that, but before you complete the first lesson, you will get a full refund, less a registration fee, perhaps 15 percent or \$150.

Once you begin sending in your lessons, your refund becomes progressively less. Generally, once you've finished half the lessons in a course, you're entitled to no refund.

There is no guarantee that even if you successfully complete your home-study program that you'll get a well-paying and exciting new job. No one could possibly guarantee that. Besides, spokesmen for several of the schools say that many of their students already have jobs in the electronics field and are more interested in promotion in the company which already employs them.

Realistically, you should expect that your school will prepare you to compete effectively for the jobs that may be available in any given location at a given time, or prepare you to go out and establish your own

business with adequate technical preparation. Naturally, you will also would need business and management skills if you work for yourself. But several of the schools offer "extras" which may give you a leg up in getting a job. One, for example, will help prepare a job hunting resume and offers a personal letter of recommendation.

Human Help. There comes a time when a feller needs a friend...a knowledgeable friend who can answer your questions when you get stuck with a home-study assignment. Most correspondence schools have instructors who will give personalized responses to student questions.

You may be asked to send your questions in writing. In fact, one of the schools says it prefers this method because it requires the student to think through his problem in depth before he can write it down. Often, this is enough to point the questioner in the right direction on his own.

Several schools have toll-free 800 phone numbers which give students the opportunity to call in and speak to an instructor about his or her difficulties.

Exams! Throughout your training you will be taking exams to test your progress. Most correspondence schools give these tests either on an open-book basis, encouraging you to use your text materials to find the correct answers, or they put you on your honor not to cheat.

However, at least one school favors proctored examinations. You and the school, jointly, will select a local person, perhaps a teacher or principal, a school counselor, even a clergyman, to oversee your tests. If you have the opportunity to take a supervised test, do so. Not only will you have something more meaningful to show a prospective employer, but even more importantly, you will have a clearer measure of your personal achievement!

You can take it. Students drop out of correspondence training programs for different reasons. One of the main causes, though, is the failure of some students to objectively evaluate their own personalities and drive. You should be enthusiastic and inspired by real hopes of a better job, but don't kid yourself—it will

(Continued on page 94)

LEADING ELECTRONICS CORRESPONDENCE SCHOOLS

NRI Schools
McGraw-Hill Continuing Education Center
3939 Wisconsin Avenue
Washington, DC 20016

Cleveland Institute
of Electronics (CIE)
1776 E. 17th Street
Cleveland, OH 44114

Commercial Technical Institute
1500 Cardinal Drive
Little Falls, NJ 07424

Grantham College
of Engineering
10570 Humbolt Street
Los Alamitos, CA 90720

ICS School of Electronics (ICS)
National Education Corp.
Oak and Pawnee Aves.
Scranton, PA 18515

National Technical Schools (NTS)
4000 South Figueroa Street
Los Angeles, CA 90037

With NRI training at home, you can...

Move up to a high paying career servicing computers

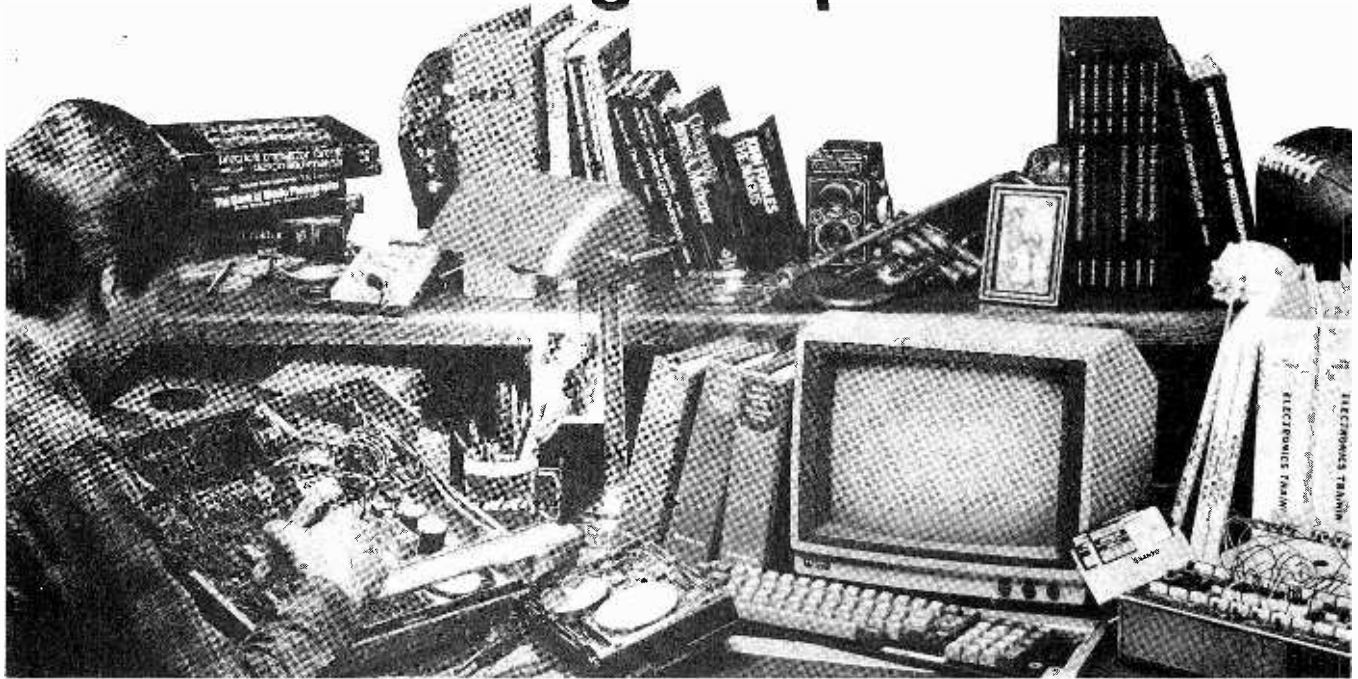

And you can start by actually building NRI's 16-bit IBM-compatible computer.

You can create your own bright, high paying future as an NRI trained computer service technician. The biggest growth in jobs between now and 1995, according to Department of Labor predictions, will occur in computer service and repair, where demand for trained technicians will double. There is still plenty of room for you to get in on the action—if you get the proper training now.

Total computer systems training, only from NRI

To learn how to work on computers, you have to get inside one. And only NRI takes you inside a computer, with total systems training that gives you hands-on experience with computers, peripherals, and software. You'll build a Sanyo MBC-550 series computer, which experts have hailed as the "most intriguing" of all the new IBM-compatibles. The Sanyo even surpasses the IBM PC in computing speed and graphics quality.

Even if you've never had any previous training in electronics, you can succeed with NRI training. You'll start with the basics, rapidly building on the fundamentals of electronics until you master advanced concepts like digital logic, microprocessor design and computer memory. You'll probe into electronic circuits, using the exclusive

NRI Discovery Lab® and professional Digital Multimeter, that you keep.

You'll assemble Sanyo's intelligent keyboard, install the power supply and disk drive, and attach the high resolution monitor—all the while performing hands-on experiments and demonstrations that reinforce your skills.

Learn to service today's computers

As you complete your Sanyo, you grasp the "secrets" that qualify you for a new career. You'll learn to program in BASIC and machine language. You'll use utility programs to check out the operation of the Sanyo's 8088 microprocessor (the same chip used in the IBM PC). And you also get over \$1,000 worth of software, including WordStar and CalcStar.

Most importantly, you'll understand the principles common to all computers. Only a person who fully understands all the fundamentals can hope to be able to tackle all computers. NRI makes sure that you'll gain the knowledge and skills to maintain, troubleshoot and service computers.

Learn at home in spare time

With NRI training, you'll learn at home on your own time. That means your preparation for a new career or part-time job doesn't have to interfere

with your current job. You'll learn at your own pace, in the comfort and convenience of your own home. No classroom pressures, no rigid night school schedules. You're always backed up by the NRI staff and your instructor, who will answer questions, give you guidance and be available for special help if you need it.

Let others worry about computers taking their jobs. With NRI training, you'll soon have computers making good paying jobs for you.

Send for Free NRI Catalog

Send the post-paid reply card today for NRI's 100-page catalog, with all the facts about computer training plus career training in Robotics, Data Communications, TV/Video Servicing and many other fields. If some other ambitious person beat you to the card, write to NRI at the address below.

NRI SCHOOLS

McGraw-Hill Continuing Education Center
3939 Wisconsin Avenue, NW
Washington, DC 20016

We'll Give You Tomorrow.



IBM is a Registered Trademark of International Business Machines Corporation.

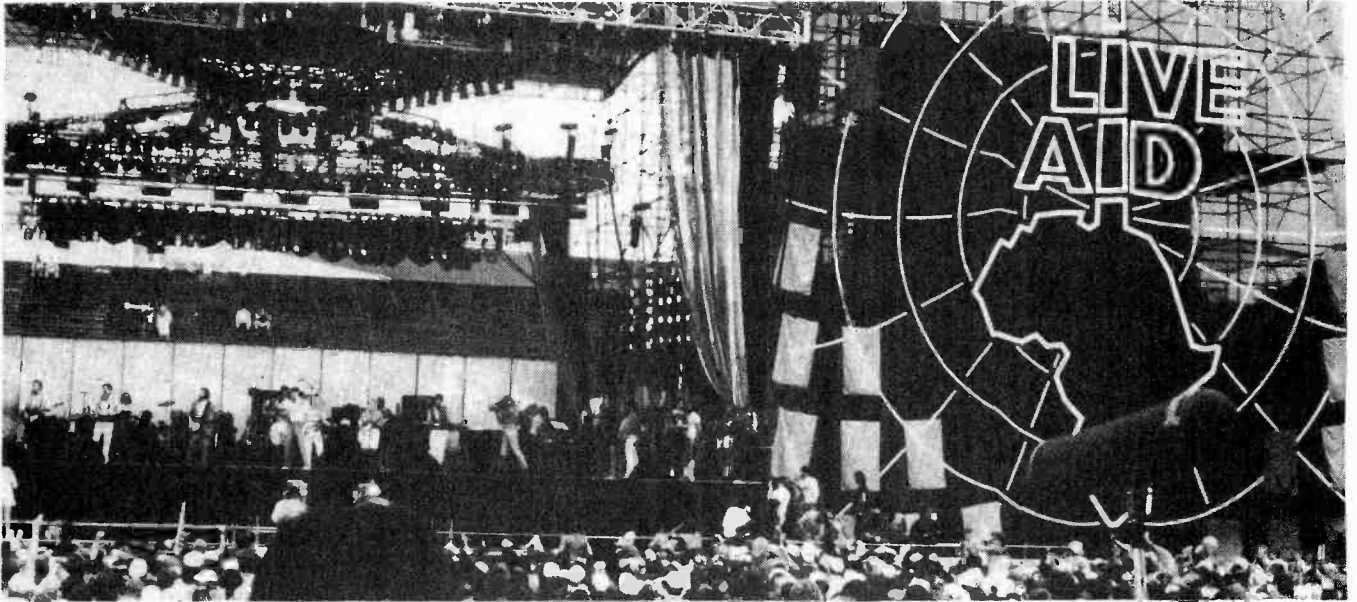

BACKSTAGE AT LIVE AID CONCERT

Multiplexing make single-cable antenna systems possible!

By Jim Strauss

Multiplex Technology has received accolades from the technical staff at the July 13th, 1985 Live Aid Concert for the role the company's ChannelPlus video multiplexer played in making video broadcasts available backstage during the 16-hour concert. With the vast number of performers and press representatives backstage at Philadelphia's JFK Stadium, technicians were faced with the problem of distributing four live television feeds to 50 TV sets located in dressing rooms, press briefing rooms and other strategic spots. Two small ChannelPlus Model P3V video multiplexing units provided a simple solution by combining the four signals, plus local broadcast TV, onto a single cable distribution system that reached all 50 TVs.

Howard Zuckerman, executive in charge of production for the concert, said "The ChannelPlus equipment greatly simplified installation and hookup by enabling us to route only one antenna cable to the various TV locations. Otherwise we would have needed five separate cables and a switch box at each location. The RCA Service people who did the work were floored by how easy it was."

In operation, ChannelPlus created new channels by accepting the video inputs from four sources and reassigning them to UHF channels 20, 26, 32 and 38 (unused channels in the Philadelphia broadcast area). All a viewer had to do in order to watch the program of

choice was to select the appropriate channel using the TV tuner. Each set then could watch: (1) the unedited live feed from the camera truck at JFK, (2) the world feed, an edited telecast to 160 countries, (3) the syndicated feed, an edited telecast to 107 TV stations in the United States, or (4) the London feed, an unedited live feed from Wembley Stadium.

ChannelPlus accepts any video source including cable service, VCR's, satellite receivers, color or black and white cameras, video disk players, cable TV decoders and computers. The quality of video is often improved by ChannelPlus, because it accepts baseband video inputs, thus by-passing the inferior channel 3 (or channel 4) modulator built into some equipment.

We are discovering many applications are being discovered each day. ChannelPlus is widely accepted by satellite receiver installers and security system specialists in addition to do-it-yourself consumers. They (the professional installers) are obviously voting for the much simpler installation with ChannelPlus. Should you be interested in multiplexing, look to ChannelPlus. It comes in residential and commercial models ranging in price from \$129.95 to \$309.95. ChannelPlus is manufactured in the United States at Multiplex Technology's headquarters in Fullerton, California. Telephone is 714/680-5848. ■

IC PROJECTS FOR EVERYONE

Integrated circuits are an electronics experimenter's dream come true, but very often we dream too little. We see diagrams for projects and we follow those diagrams, wire for wire, ending up with a project that someone else designed for their needs that almost fills our needs. Every project should be looked at with our eyes, not that of the author. We should look to redesign, modify, or add features that will redirect the project's function to fill the need we have. Otherwise, we become appliance builders, and eventually, get lazy and buy appliances at the local discount stores. The projects in this section are designed to provide a basic feature that can be used in larger projects, or by themselves as a learning guide.

So here we go again! Build them! Modify them! Improve them! Do that, and that alone, and you will have more fun than we did preparing this article for publication. ■

TOUCHY FLIP-FLOPPING

Here is a simple 555 timer circuit that is used as a touch-triggered bi-stable flip-flop. Refer to Fig. 1. Touching touch pad TP2 causes the 555's output to go high. Because the voltage at pin 3 and the power

supply are almost equal, light-emitting diode LED1 goes out and LED2 which is now between a high and ground will come on. Touching TP1 causes the output at pin 3 to go low. LED1 now sees the full 9 volts

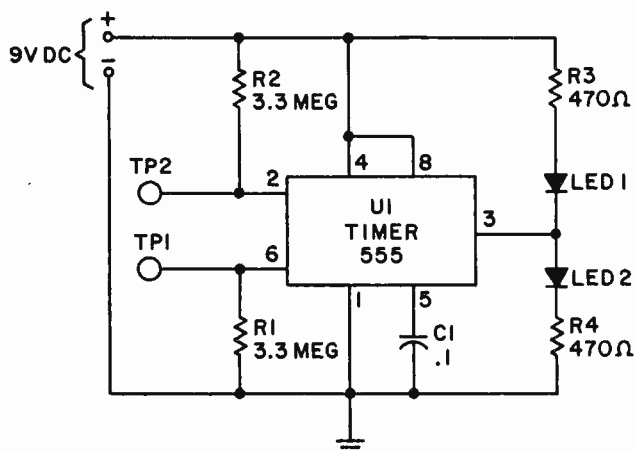

PARTS LIST FOR TOUCH-TRIGGERED FLIP-FLOP

- C1—.1-uF, tubular or ceramic capacitor
- LED1, LED2—Light-emitting diode, any color
- R1, R2—3.3-Megohms, ¼-watt, 10% resistor
- R3, R4—470-ohm, ½-watt, 5% resistor
- TP1, TP2—small metallic contacts (screw heads) used as touch pads
- U1—555 timer integrated circuit

IC TESTBENCH

across it, and LED2 has both ends of the diode connected to ground (or lows).

As the circuit is shown, the light-emitting diodes can be located near the button that will turn them off, so that it can be made a part of a child's toy. One LED

can be red and the other can be green so that a toy traffic light can be simulated. Tapping off from pin 3, other circuits can be controlled for purposes more mundane than children's toys. The LED's can be used as indicators for a circuit action or state.

RESISTANCE COMPARATOR — NULL DETECTOR

Here is a circuit that appears to have few redeeming applications, yet to the imaginative experimenter it is the fuel to fire the flames of many projects. In the form that it is shown in Fig. 2, the

circuit compares an unknown resistor (R2) against another (R1) that is used as the reference. The two resistors form a voltage divider and a portion of the 9-volt DC supply is delivered to U1. Potentiometer R3 is

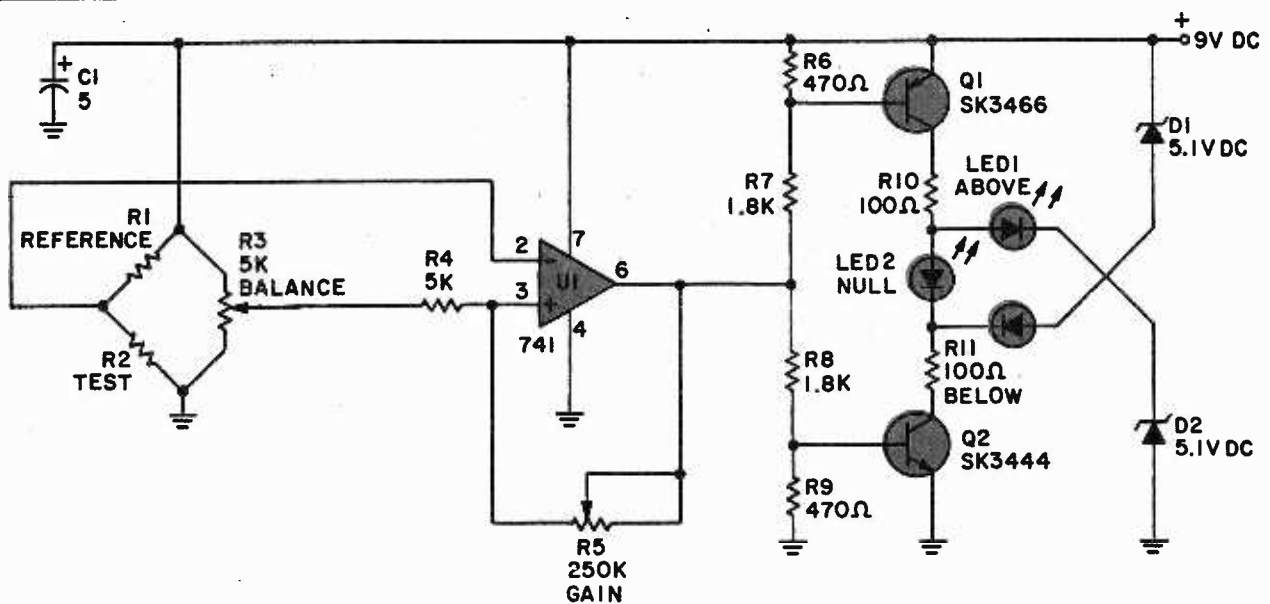

PARTS LIST FOR THE RESISTANCE COMPARATOR

- C1—5-µF, 16-WVDC, electrolytic capacitor
- D1, D2—5.1-volt, 400-mA, Zener diode
- LED1-LED3— Light emitting diode (same color of each different)
- R1—Reference resistor, ¼-watt for resistors above 1000-ohms
- R2—Test resistor
- R3—5000-ohm, 10-turn trimmer-type potentiometer
- R4—4700-ohm, ¼-watt, 5% resistor
- R5—25,000-ohm, linear-taper potentiometer
- R6, R9—470-ohm, ½-watt, 5% resistor
- R7, R8—1800-ohm, ½-watt, 5% resistor
- R10, R11—100-ohm, ½-watt, 5% resistors
- Q1—SK3466, 2N4258, 2N4258A, OR ECG159, PNP transistor
- Q2—SK3444, 2N3646, OR ECG123AP NPN transistor
- U1—741 operational amplifier (op-amp)

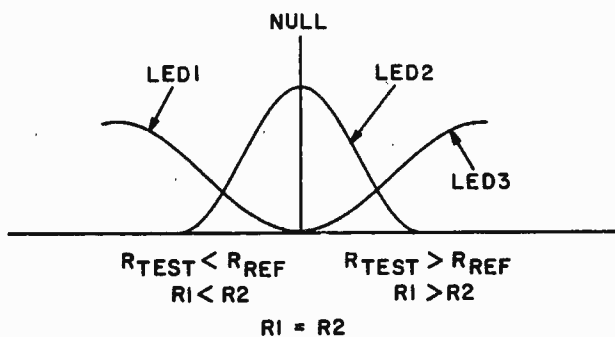

IC TESTBENCH

preset and locked after it is set to a position where the circuit nulls out when a pair of matched resistors are used in place of R1 and R2 at the initial setup. A 10-turn trimmer would be ideal for R3. It should deliver exactly 4.5-volts DC to pin 2 of U1 when set to the midpoint of its resistance range.

Op-amp U1 compares the two inputs, and when R1=R2, the output of the 741 should be exactly 4.5-volts DC and LED 2 should light. At a null indication, both transistors, Q1 and Q2, conduct passing current through LED2. There is insufficient voltage across the other two light-emitting diodes (LED1 AND LED3), because their respective series Zener diodes (D1 and D2) and one of the 100-ohm resistors in series with them and the power supply drop most of the 9 volt, leaving too little voltage to fire the off-null light-emitting diodes.

Should R2, the test resistor, be below the value of R1, the voltage to pin 2 will be reduced below the null value and U1's output will increase. Transistor Q1 will conduct more and Q2 will be driven to cutoff. The

effect on LED3 is that it comes on. LED1 remains off. Led 2 will begin to diminish and even go off when the unbalance is severe. When R1 is above the value of R2, the opposite indications are given by the light-emitting diode.

The curves in Fig 3 present the expected LED illumination levels. Depending on the resistances used in the input circuit, LED1 and LED3 may or may not be completely illuminated at the null point. Adjust R5 as required for optimum illumination indication. Zener diodes D1 and D2 may cause some unbalance. Their voltages should be checked with a 3-1/2 digit voltmeter. Five-percent resistors are used for R6 through R11 provided that the indications desired be in the 5% range. More accurate results can be obtained with lower valued tolerances, or careful selection and matching of components using 3-1/2 or 4-1/2-digit ohmmeters.

How you use or redesign the input circuit to the 741 op-amp (U1) will open many possibilities—resistance checking is the least of them.

DIVIDE BY N

Many times in a logic-circuit development it's necessary to divide by 4, or 7 or 9, or any integer between 2 and 9. Then, when the job is done, you discover that the division should be by the interger 3 or 5, or any other integer between 2 and 10. Back to the drawing board? No way! With the simple circuit shown in Fig. 4 all you do is change one connection to permit division by another integer.

The work is done in series the 4017A Johnson decade counter which is shown as a divide-by-three counter. To divide by another integer refer first to the

Table along side the diagram (FIG. 4), and connect pin 15 to the pin that corresponds to the integer you select. The Table lists the integer "10" which is actually the output. This pin is internally connected to the reset pin (15) and after a count of 10, the chip will begin anew for the next division. In Fig. 4 the reset pin (15) is held low by R1 which will be driven high by pin 6 (integer 3 when division by 3 is desired) in the diagram.

Pin 13 is tied to ground—this is the *enable* pin that permits division to start.

Pin No.	Divide by
2	1
4	2
7	3
10	4
1	5
5	6
6	7
9	8
11	9
3	10

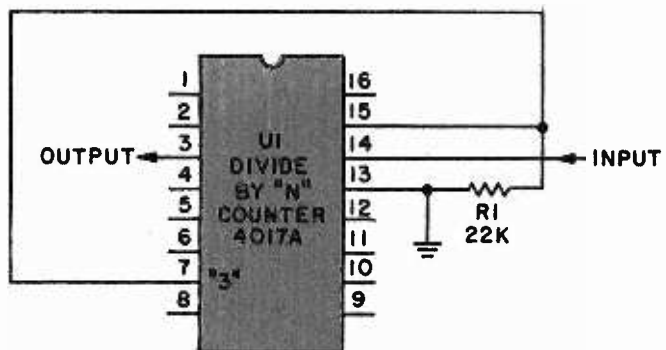

PARTS LIST FOR DIVIDE-BY-"N" COUNTER

R1—22,000-ohm, 1/4-watt, 5% resistor

U1—4017A divide-by-"n" (Johnson) counter

IC TESTBENCH

HIGH-VOLTAGE, LOW-CURRENT GENERATOR

Most integrated circuits use voltage ratings of +5, 15, +12, -12, and 24. Sometimes, you could use something that is the 50 volt range and that would normally require big bucks, big parts, and a big headache, when the gadget is inexpensive to begin with, and there's no room in the cabinet of the original device. One typical use was with a megger (high-resistance meter). You can probably come up with several of your own.

Whatever the reason, here's where a 555 timer rides in like the Lone Ranger to save the day. The circuit is almost like any other where the 555 is used as a multivibrator. To keep the size down the transformer

can be an audio type tuned to resonance—that can get tricky. Capacitor C4 is critical. Should you decide to use a small filament transformer, connect the primary (117-VAC) to the AC output side as shown in Fig 5.

You will have to select the value for C4 by trial and error, because the chances are you cannot find the frequency characteristics curves for the transformer in your junkbox. Vary the settings of the wiper for R2 and R3 and select various values for C4 until the output of the transformer is optimized. This is a fun testbench project that will find its way into many projects.

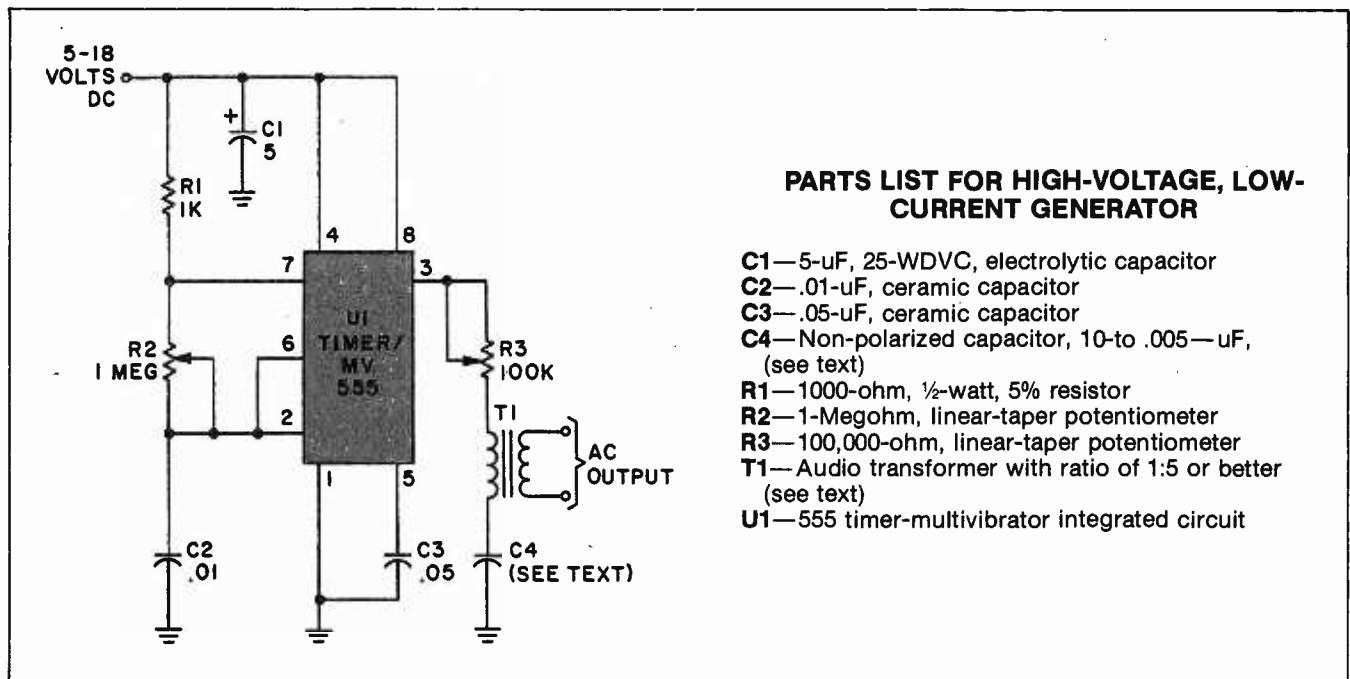

PARTS LIST FOR HIGH-VOLTAGE, LOW-CURRENT GENERATOR

- C1—5- μ F, 25-WDVC, electrolytic capacitor
- C2—.01- μ F, ceramic capacitor
- C3—.05- μ F, ceramic capacitor
- C4—Non-polarized capacitor, 10-to .005- μ F, (see text)
- R1—1000-ohm, $\frac{1}{2}$ -watt, 5% resistor
- R2—1-Megohm, linear-taper potentiometer
- R3—100,000-ohm, linear-taper potentiometer
- T1—Audio transformer with ratio of 1:5 or better (see text)
- U1—555 timer-multivibrator integrated circuit

UNIVERSAL RELAY DRIVER

What's so universal about the Universal Driver? Our intent is to make it universal so that the hundreds of letters we receive each year on this subject will diminish! When the current capability of the miniature relays intended for direct drive by logic chips is exceeded, the experimenter has to use larger relays for the higher-rated contacts.

The circuit in Fig. 6 nests comfortably in TTL and CMOS circuits yet it can switch inductive loads. 28-

volt relays are available. A greater supply of automotive 12-volt relays are on auto-supply store's shelves. The latter have high-current capacity, but should be limited to under 20-VAC operation.

Tie the op-amp to the logic circuit so that U1 is driven low to energize the relay coil. Zener diode D1 quickly squashes any oscillations that exceed 30 volts preventing U1 from being struck by "lightning."

IC TESTBENCH

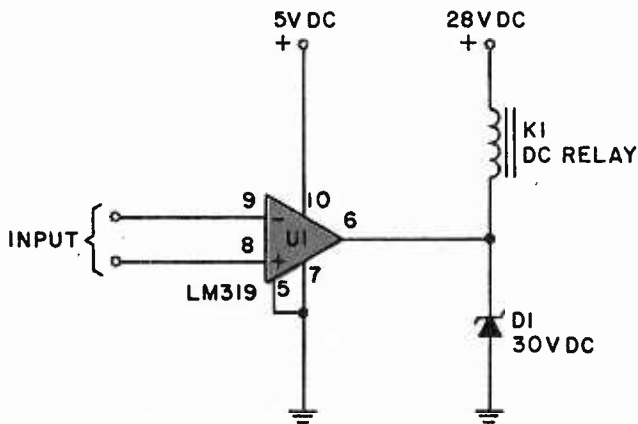

PARTS LIST FOR UNIVERSAL RELAY DRIVER

- D1—Zener diode, 2-volts higher than applied relay-coil voltage, 1-watt
- K1—Relay, DC-coil type (see text)
- U1—LM319 op-amp

MINIMUM-EFFORT FLASHER

We mean "minimum effort" when we say Minimum-effort Flasher. This simple circuit is so simple we expect it to be the first electronic circuit to ever be placed on a commemorative postage stamp—that's all the space it takes!

Take a look at Fig. 7 if you are a doubter. Just four elements which includes the light-emitting diode. The circuit values selected offer a flashing rate of 1.1

Hertz with an average drain of .32 milliamperes. A single penlight cell will power the unit for a week or more.

Make a printed-circuit board for this project, because many of your friends will want one for themselves. We wired ours by soldering leads to the dry cell and connecting it to the board as if it were a large capacitor.

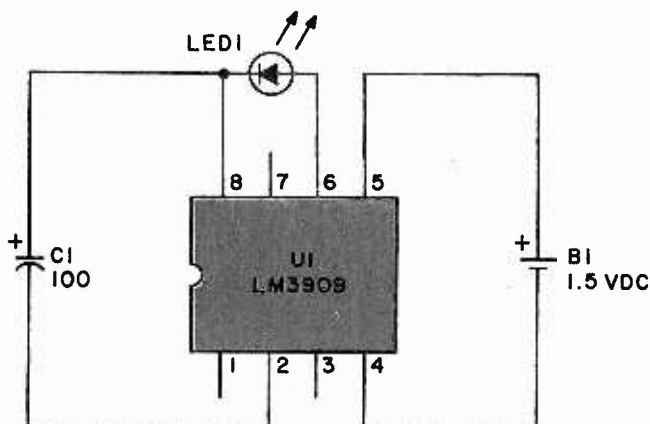

PARTS LIST FOR MINIMUM-EFFORT FLASHER

- B1—1.5-volt, AA-size, dry cell
- C1—100-uF, 10-WVDC (or less), electrolytic capacitor
- LED1—Light-emitting diode, 20-mA type or lower
- U1—3909 flasher integrated-circuit

WINK-A-BLINK FLASHER

Sometimes you hear the expression, "...a cute circuit...!" Well, how can a circuit be cute? well....Here's a cute circuit of two blinking light-emitting diodes. It's not the flashing diodes that make it cute, is the technique that is. Keep this circuit in mind for it will be useful as an alternating

switching circuit in other projects. As for now, build it, because it is a "cute circuit!" See Fig. 8.

The circuit uses 4069 chip with six inverters on board. Two inverters (U1-a and U1-b) are used for the free-running multivibrator section. Resistor R1 and capacitor C1 determine the free-running rate. Two

IC TESTBENCH

other inverters (U1-c and U1-d) buffer the multivibrator section from the LED's. Since the two buffers obtain signals from either end of a single inverter, their inputs are always out of phase with respect to each other; when one is high, the other is low. Thus, when one output is high, the other is low so that the current passing through R2 is flipping back and forth; and the light-emitting diodes blink back and forth. Cute!

Depending on the supply voltage used, R2's

resistance may have to be lower to obtain a brighter light from the LED's. If you don't have a 4069 handy, use a 7404 after checking out the Cook Book. For the purpose of good design practice, the unused inverter sections in Fig. 8 are shown with their inputs grounded. This grounding prevents the unused inverters from introducing unexplained oscillations and noises in the circuit. It's not critical here, but this is a good place to start "good practice."

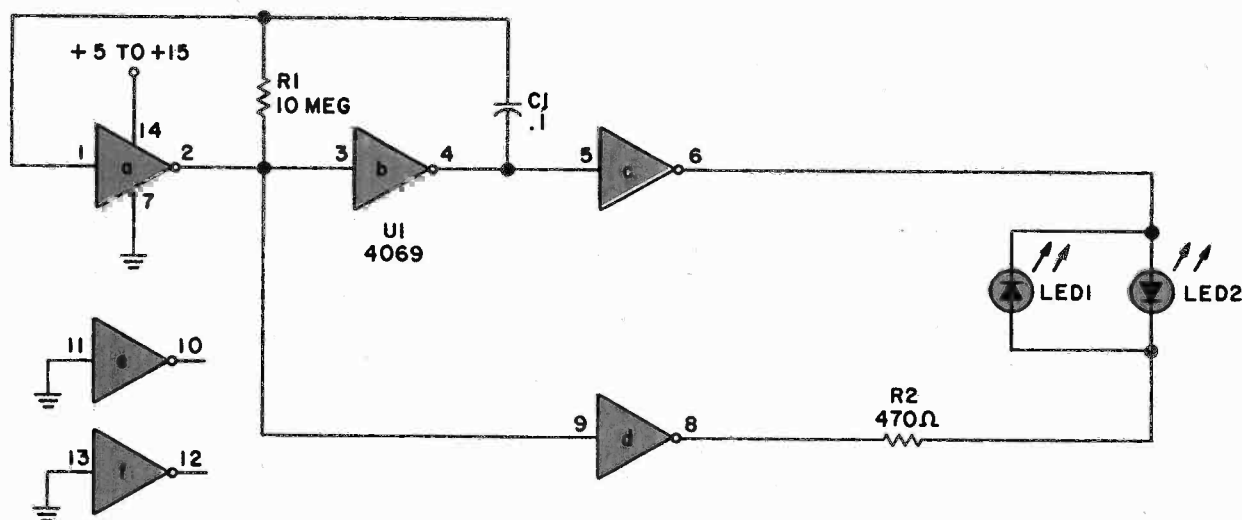

PARTS LIST FOR THE WINK-A-BLINK FLASHER

- C1— .1-uF, ceramic capacitor
- LED1, LED2—Light-emitting diode (any type)
- R1—10-Megohm, 1/8-watt, 5% resistor
- R2—470-ohm, 1/2-watt, 5% resistor
- U1—4060 hex inverter integrated circuit

BUDGET BCD-TO-ANALOG READOUT

This Budget BCD-to-Analog Readout (see Fig. 9) circuit is "an idea" for many future projects. The 74141 integrated circuit was designed to convert a four-bit BCD input to an output DC voltage stepping in one-volt increments from zero to nine volts. The 74141 is famous as a Nixie-tube driver.

As the BCD input enters U1 a voltage proportional to the input signal—its analog—is developed across the output resistors. The op-amp, U2, serves as a

buffer for the following stages. A voltmeter may be tied too U2's output to provide a readout. A digital meter will give the Nixie effect for demonstration purposes.

Resistors R1-R9 can either be hand selected from surplus stock or fabricated from parallel units. The power supply is rated at 10 volts exactly, which could be achieved using a Zener diode or adjustable IC regulator chip.

IC TESTBENCH

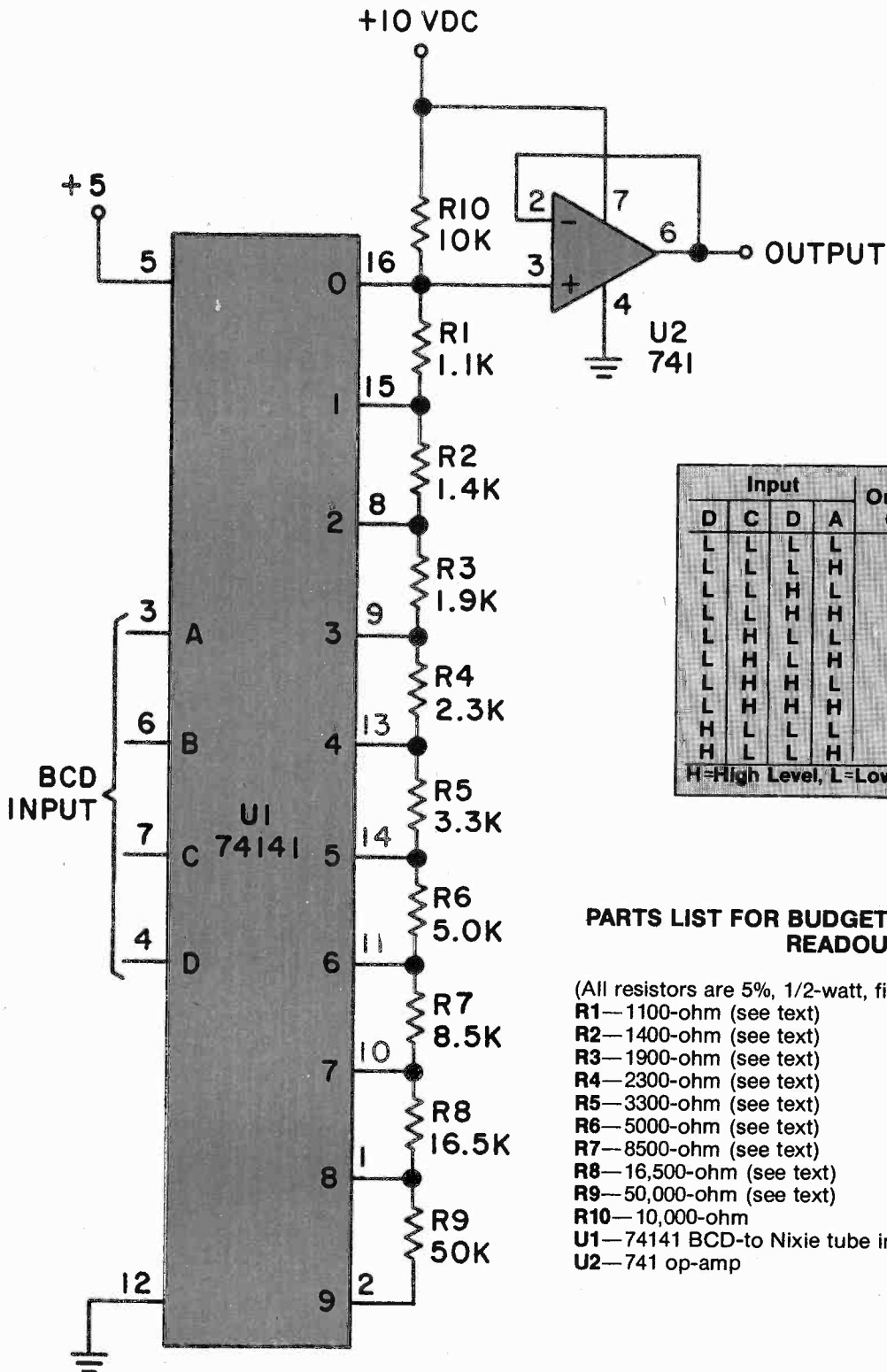

Input				Output
D	C	B	A	On
L	L	L	L	0
L	L	L	H	1
L	L	H	L	2
L	L	H	H	3
L	H	L	L	4
L	H	L	H	5
L	H	H	L	6
L	H	H	H	7
H	L	L	L	8
H	L	L	H	9

H=High Level, L=Low Level

PARTS LIST FOR BUDGET BCD-TO-ANALOG READOUT

- (All resistors are 5%, 1/2-watt, fixed units)
- R1—1100-ohm (see text)
 - R2—1400-ohm (see text)
 - R3—1900-ohm (see text)
 - R4—2300-ohm (see text)
 - R5—3300-ohm (see text)
 - R6—5000-ohm (see text)
 - R7—8500-ohm (see text)
 - R8—16,500-ohm (see text)
 - R9—50,000-ohm (see text)
 - R10—10,000-ohm
 - U1—74141 BCD-to Nixie tube integrated circuit
 - U2—741 op-amp

THE 80 TUNE COMPUTER

By Doyle W. Howard

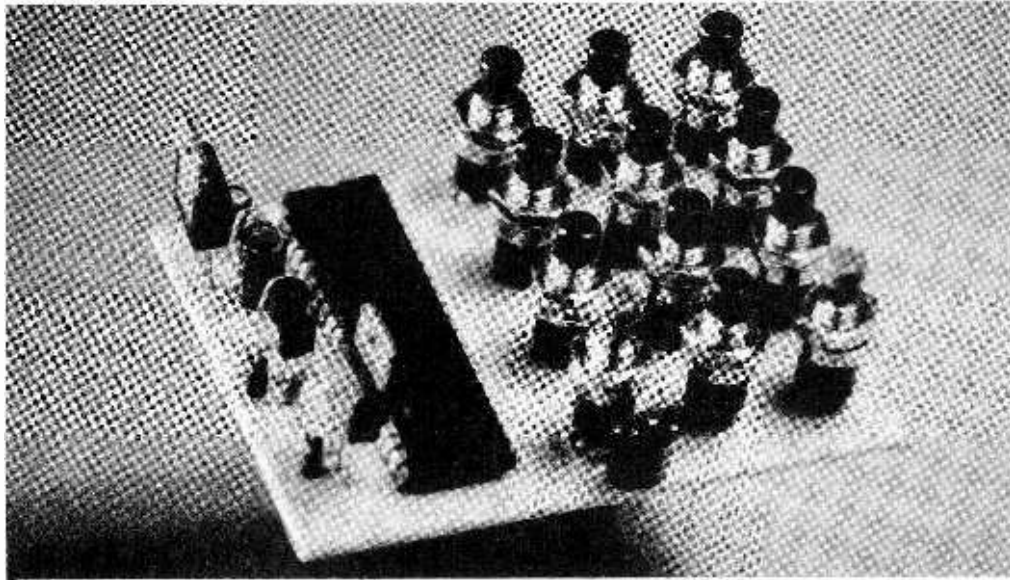

The 80-Tune Computer is a project which is not only easy to build but also fun to use. Its uses are many and are limited only by the imagination of the builder. This is an excellent beginner's project because of its simplicity. A masked microprocessor (special Integrated Circuit, or IC) does all the work.

Any of the 80 songs can be selected by the telephone-style keypad. A push of the *Play* button makes the selection. The *Stop* button resets the microprocessor. The selected tune will start each time the *Play* button is pushed as long as power is on and no

Reset (or *Stop*) occurs.

This computer chip was originally designed as part of a musical car horn, and the circuit is capable of driving a loudspeaker to a high output level. Since it was designed as a loud horn for cars, the circuit requires plenty of power: a source capable of delivering 9 to 14 Volts DC at 50 MA minimum, and up to 0.5 Amps, depending on the particular speaker impedance (ohms). When actually used in a car, the automobile battery easily supplies plenty of amps (current). It's only if you want to get lots of power output when using a 12-VDC power supply *other* than a car battery that you'll need a hefty 12-volt supply. In addition to making a great musical car horn, the project can be used as the basis for a musical *Doorbell*, a musical *Telephone* ringer, a music-on-hold circuit, or even a musical *Alarm* circuit. The following is a description of how to assemble the board, how it works, and how to use it in some of these applications.

The circuit board has just 15 parts, plus twelve push button switches. The board was designed to accept Radio Shack's (part number 275-1574) pushbutton switches. Since there is a hex nut on this switch, it is easier to mount the twelve switches to their positions on the panel before the tabs are soldered to the circuit board. This assures that the mounting flange is flush

TELEPHONE RING DETECT CIRCUITS

MAGNETIC REED SWITCH



Wrap glass reed with electrical tape and tape to the ringer coil inside the telephone. The magnetic field produced by the coil will close the reed when the ringing voltage is present.

HOBBY DEPARTMENT

with the panel. The holes for the panel can be located by using the circuit board as a template. Use either the left solder tab hole or the right solder tab hole and mark the panel of the selected chassis for each of the twelve switch positions.

Resistor R5 and capacitor C3 form a *Reset* time-delay RC network. Pin 39 of U1 is the *Reset* pin of the microprocessor. This pin has an internal pull-up resistor which keeps the terminal at 5 Volts. The *Stop* button places a brief pull-down path on the reset pin

through C3. The momentary ground resets the system as C3 charges. When the *Stop* button is released, the charged capacitor discharges through R5. The *Play* switch has two extra solder pads marked A and B which allow an external switch to be wired in parallel with the *Play* switch so that the circuit can be activated remotely.

The microprocessor requires +5 volts, which is connected to pins 38 and 40 of U1. The 5-V supply is regulated by U2, a 7805 voltage regulator IC.

80 TUNE COMPUTER

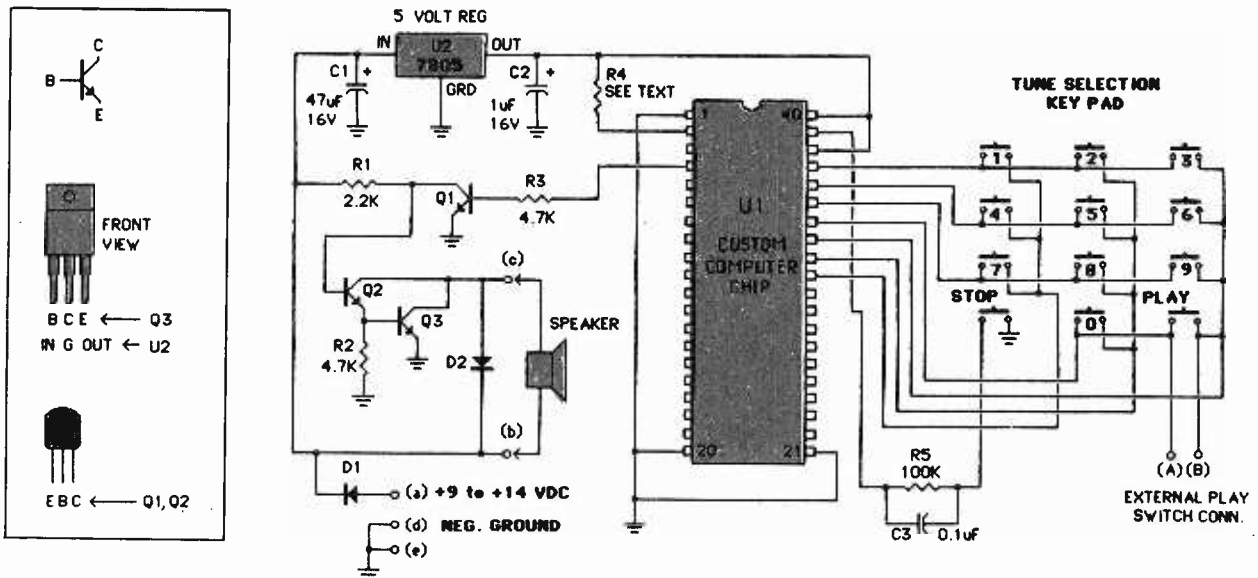

80 TUNE COMPUTER CIRCUIT CARD COMPONENT PLACEMENT

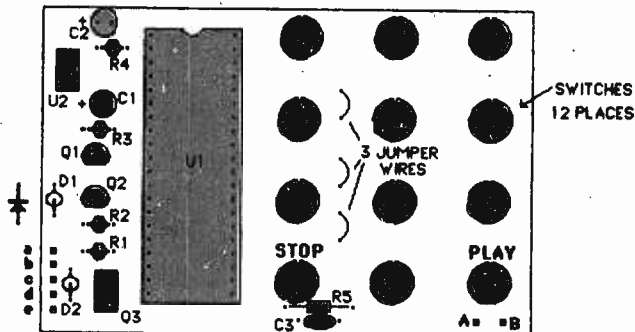

PARTS LIST FOR 80 TUNE COMPUTER

- R1—Resistor, 2.2K, 1/4W, 5%. Radio Shack 271-1325
- R2, R3—Resistor 4.7K, 1/4W, 5%. Radio Shack 271-1330
- R4—Resistor 6.8K, 1/4W, 5%. Radio Shack 271-1328 (2)
- R5—Resistor 100K, 1/4W, 5%. Radio Shack 271-1347
- C1—Capacitor, 47uF, 16V. Radio Shack 272-1027
- C2—Capacitor 1uF, 16V. Radio Shack 272-1434
- C3—Capacitor 0.1 uF, 50V. Radio Shack 272-1069
- D1, D2—Diode 1N4001, 1 AMP, 50V. Radio Shack 276-1101
- Q1, Q2—Transistor, 2N2222. Radio Shack 276-2009
- Q3—Transistor, TIP31. Radio Shack 276-2017
- U2—7805 Voltage Regulator. Radio Shack 276-1770
- S1-S12—Key pad switches (12). Radio Shack 275-1574
- SPKR—Car Horn. Radio Shack 40-1244
- SPKR—Door Bell. Radio Shack 40-246

U1 Custom Microprocessor \$8.00
 PCB Printed Circuit Board \$3.95
 Add \$1.50 for postage and handling.
 For above, send check or money order to
 C & E Hobby Handbooks, Inc.
 P.O. Box #5148 North Branch, NJ 08878

HOBBY DEPARTMENT

ALTERNATE RING DETECTOR CIRCUIT

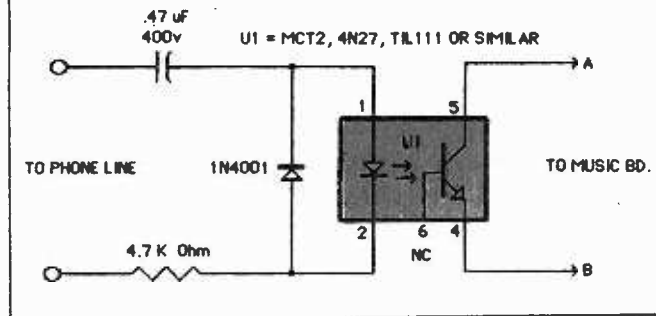

Capacitors C1 on the input to the regulator and C2 on the output of the regulator act as filter capacitors to remove high frequency noise. Pins 1, 20, and 21 of U1 are grounded. Pin 2 of U1 is connected through R4 to the +5-V supply. The value of R4 is typically 6.8 K ohms but can be decreased to cause the microprocessor to play faster, or increased to make the songs play slower. Pins 31, 32, and 33 of U1 are the column connections for the switch matrix. Pin 31 is column one, and requires three jumper wires to connect it to the top three switches in the matrix. Pins 34, 35, 36, and 37 the row connections to the switch matrix. The processor scans these lines to sense a closed switch.

The main power input is connected through diode D1. This is a 1N4001 rated for 50 volts at 1 amp. This diode protects against accidental voltage reversals. It can also be used as a rectifier diode for connecting a doorbell transformer as a power source. The doorbell transformer should not exceed 10 VAC, and C1 may need to be increased for extra filtering. The processor output is pin 4 which drives the three output transistors, Q1 Q2 and Q3. One side of the speaker connects to the positive supply voltage. Transistor Q3 switches the other side of the speaker to ground at a rate controlled by the processor. A four ohm, five-watt horn speaker will produce the highest sound level. If lower sound level is acceptable, a resistor can be connected in series with the speaker. Q3 is a power transistor capable of switching a 3-amp load; however, no heat sink is required for Q3 or U2. If extra clearance is required, Q3 and U2 can be mounted below the board as long as the same pins are soldered to the same pads on the circuit board and the metal tabs do not touch any metal surface. When Q3 switches open, the flyback voltage generated by the speaker can be quite high. Diode D2 is used to discharge this flyback transient pulse which might otherwise damage Q3.

A wall charger type 9V, 200 mA power supply will make a good source for many of the projects such as this telephone ringer. A simple telephone ringer can be made by using a glass reed switch connected with a

80 TUNE COMPUTER SONG LIST

0 AMERICA
 1 ANCHORS AWEIGH
 2 BATTLE HYMN REPUBLIC
 3 CAISSONS GO ROLLING
 4 CALL TO COLORS
 5 CAVALRY CHARGE
 6 DIXIE
 7 HAIL BRITANNIA
 8 YANKEE DOODLE DANDY
 9 LA MARSEILLAISE
 10 MARINE HYMN
 11 REVEILLE
 12 STARS & STRIPES
 13 TAPS
 14 WILD BLUE YONDER
 15 ALOUETTE
 16 AREVEDERCHI ROMA
 17 CAMPTOWN RACES
 18 CANDY MAN
 19 CHATTANOOGA CHOO-CHOO
 20 CLEMENTINE
 21 DALLAS THEME
 22 EL PASO
 23 THE ENTERTAINER
 24 JOLLY GOOD FELLOW
 25 FUNERAL MARCH
 26 HAVA NAGILAH

27 IN HEAVEN IS NO BEER
 28 JIMMY CRACK CORN
 29 JINGLE BELLS
 30 KING OF ROAD
 31 LA CUCARACHA
 32 LONE RANGER
 33 MODEL T
 34 THE OLD GREY MARE
 35 POPEYE
 36 RAINDROPS
 37 SAILORS HORNSPIPE
 38 SAN ANTONIO ROSE
 39 SEE THE USA
 40 OUT TO THE BALLGAME
 41 TIJUANA TAXI
 42 TWO BITS
 43 WABASH CANNONBALL
 44 SAINTS GO MARCHING
 45 WOODY WOOPECKER
 46 YELLOW ROSE OF TEXAS
 47 ACROSS THE FIELD
 48 AGGIE WAR HYMN
 49 ARKANSAS FIGHT SONG
 50 BE SHARP
 51 BOOMER SOONER
 52 BOW DOWN WASHINGTON

53 BUCKLE DOWN WINSOCKI
 54 CHARGE
 55 DEAR OLD NEBRASKA U.
 56 THE EYES OF TEXAS
 57 ABOVE CAYUGA'S WATERS
 58 FIGHT ON USC
 59 GO, NORTHWESTERN
 60 HAIL PURDUE
 61 HEY LOOK ME OVER
 62 HOLD THAT TIGER
 63 ILLINOIS LOYALTY
 64 INDIANA, OUR INDINA
 64 I'M A JAYHAWK
 66 IOWA FIGHT SONG
 67 LOVE YA BLUE
 68 MICHIGAN STATE FIGHT
 69 MINNESOTA ROUSER
 70 NITTANY LION
 71 NOTRE DAME FIGHT
 72 OLE MISS
 73 ON, BRAVE ARMY TEAM
 74 ON WISCONSIN
 75 WRECK FROM GA. TECH
 76 ROLL ON TULANE
 77 THE VICTORS
 78 WASHINGTON/LEE SWING
 79 YEA ALABAMA

HOBBY DEPARTMENT

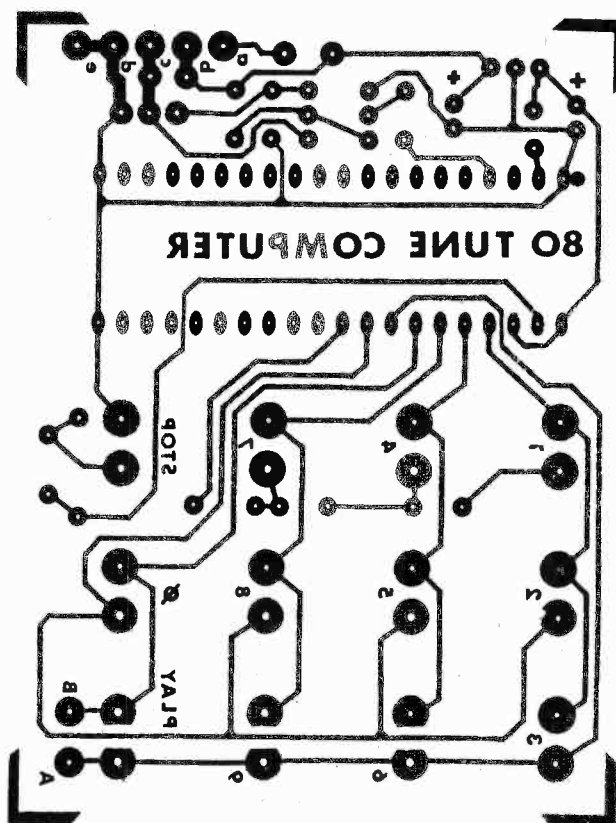
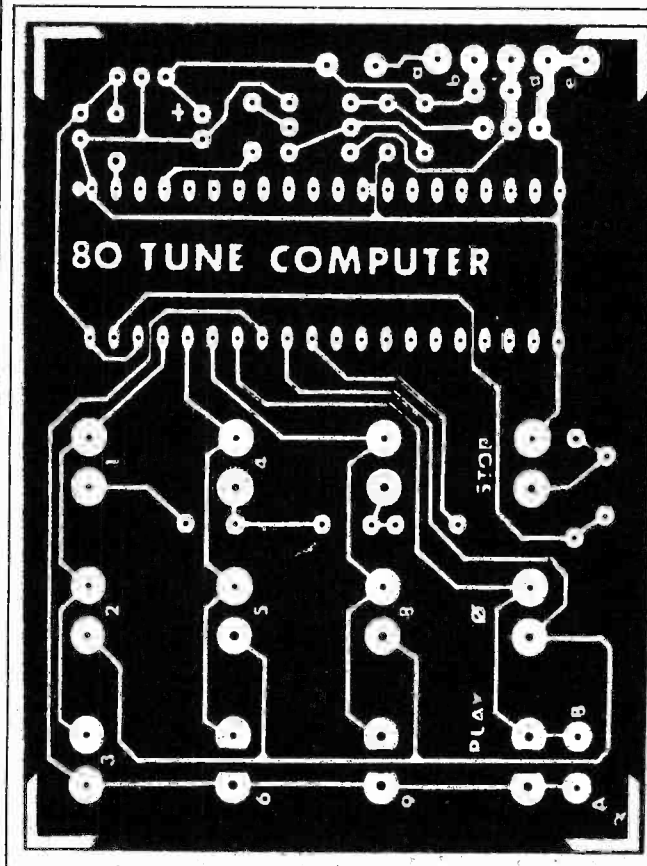

length of wire to solder pads "A" and "B". The reed switch is taped to the ringer coil inside the telephone. A piece of felt is wrapped around the clapper of the ringer to stop the bell sound. This type of connection, however, will not work with newer electronic ringers. An alternate telephone ring detector can be made using an opto-isolator to connect to the line. The ringing voltage can be between 40 and 100 VAC and from 16 Hertz to about 65 Hertz. This signal is connected to the input of the opto-isolator through a DC blocking capacitor and then through a limiter resistor which controls how much load the ring detector places on the line. A protection diode is connected across the LED of the opto-isolator for protection against the polarity reversal.

One way of making a musical doorbell is to use a picture frame with a $\frac{3}{4}$ inch deep space behind it. A 5×7 inch picture frame is about the right size. Cut a piece of $\frac{1}{4}$ inch sheet plastic to fit the 5×7 opening and mount the circuit board, speaker, and terminal blocks to the plastic. A 45-ohm speaker was found to be about right for the proper sound level. An 8-ohm speaker with a series resistor of 30 to 100 Ohms will work also. The front of the plastic sheet can be dressed up with glitter, sea shells, or something similar.

An alarm circuit can be made by connecting a mercury switch such as Radio Shack part number 275-

027 to pads A & B with a long piece of wire. The reed switch is taped to the ringer coil inside the telephone. A piece of felt is wrapped around the clapper of the ringer to stop the bell sound. This type of connection, however, will not work with newer electronic ringers. An alternate telephone ring detector can be made using an opto-isolator to connect to the line. The ringing voltage can be between 40 and 100 VAC and from 16 Hertz to about 65 Hertz. This signal is connected to the input of the opto-isolator through a DC blocking capacitor and then through a limiter resistor which controls how much load the ring detector places on the line. A protection diode is connected across the LED of the opto-isolator for protection against the polarity reversal.

The car horn can be built in a small box such as the Radio Shack part number 270-233. Mark and drill the holes for the keypad switches and a power switch in the cover plate. Drill a small hole in the back of the plastic case to bring out wire leads from solder pads a, b, c, and d. Connect the a wire to the positive side of the car's electrical circuit. Connect the d wire to a good chassis ground. Extra long wire should be used for b and c to allow them to reach the front grille section of the car. Use an outdoor horn (PA) speaker such as Radio Shack 40-1236 or 40-1244.

Before applying power to the finished board, it's a good idea to look carefully for parts that may have been installed incorrectly. Check to see that the positive side of C1 and C2 are connected to the positive side of the supply. Inspect diode D1 and D2 to insure that the lead on their banded ends face toward the middle of the board. Make sure Q1, Q2, Q3, U1, and U2 are mounted correctly. Check to see that all solder joints are good and that no solder bridges are on the board. Now connect the power and start choosing your favorite tunes!

THE TALE OF TWO COMETS

In 1687 Sir Isaac Newton boldly announced: "I now demonstrate the frame of the System of the World." His Principia did just that, formulating among other wonders the law of universal gravitation. He banished doubt and tossed aside mystical beliefs cherished since the time of Aristotle. Ending two thousand years of superstition, guesswork and experimentation, Newton presented to the world mathematical proof that an everyday force such as gravity works throughout the universe. Here, his Principia proclaimed, is evidence that the world near and far operates according to quantifiable rules. The same invisible force that keeps the captive moon in orbit around the orbiting water planet also knocks an apple from a tree.

But Isaac Newton wasn't so bold seven years before. In fact, he wasn't even certain of his own calculations until a spectacular comet lit up the sky at Christmas time in 1680.

Master inventor and optician Robert Hooke made this low-key entry into his diary December 12, 1680: "comet appeared with a very long blaze." This "blaze," or tail, was seen all over the world from Paris to the new colony of Maryland, where another diarist called attention to "a Sword streaming from the horizon."

England's Astronomer Royal, John Flamsteed, joined in the excitement, predicting to a colleague, "I believe we shall see it longer than any hath been seen of late." Flamsteed was referring to another comet spotted heading toward the sun only a month before.

Another distinguished British astronomer, Edmund Halley, wrote to Hooke at Christmas that he too had seen the new comet while crossing the English Channel to France. And the same day Hooke made his diary entry, Isaac Newton began recording the comet's tail observations into his notebook.

Wise men all over Europe had the new bright spot in their eyes and agreed with the Astronomer Royal that what they saw was "some planet belonging formerly to another vortex now ruined," another wandering fragment far from earth which, according to the great Kepler, produced reflected light as it sped in a straight line out to infinity.



NEWTON

Yet this standard, sixty-year-old explanation didn't sit well with Flamsteed, who suspected that the December comet and the November comet might be one and the same. To go with this belief, he had a hunch and a plausible explanation: the November comet, headed toward the sun, had somehow reversed direction, perhaps due to the sun's magnetism, and had come out from behind the sun to reappear in December's sky. Two tails—November's aimed toward the sun and December's racing away from it—could be from the same comet.

His colleagues, Hooke and Halley among them, mulled over the interesting theory, but finally settled on the more apparent possibility that November's comet had either burned up after impact with the sun or had simply disappeared beyond sight forever. December's comet was a separate phenomenon. With no means of quantifying a belief, they were forced to speculate.

When pressed for his opinion, Cambridge Universi-

ty's renowned mathematician, Isaac Newton, disagreed with Flamsteed. For the Great Quantifier, there were two 1680 comets. His still-forming laws of physics allowed for predictable planetary motion, but had no room for those mysterious cosmic outlaws called comets. Newton filed his observations in his notebook and went back to studying optics.

By September of 1682 Edmund Halley had lost a lot of sleep, arising before dawn each day to adjust telescope and sextant in his home observatory north of London. What he had in sight was the comet that was to immortalize his name. He saw clearly and "outgoing" comet, its tail racing away from the sun in the manner of December, 1680's comet. And it made him wonder aloud with Hooke and Flamsteed about a pet theory: the inward force of attraction between the planets and the sun decrease in inverse proportion to the square of the distance between them.

If Isaac Newton believed this was so for the mutual attraction of the earth and its moon; and if this was also true for the newly discovered moons of Jupiter, then might it also be true of comets? Can they move in orbit around the focus of the sun? Does gravity control their motion too? It was a hunch, needing only a formula to advance it to a truth.

France's Royal Astronomer, Giovanni Cassini, seemed to agree with this theory in his year-old "Observations on the Comet." According to Cassini, not only was the November-December comet of 1680 a single phenomenon, but it was also the very one tracked and studied in 1577 by Tycho Brahe. Comets, he said, have orbits. They can and do return.

Hooke's newly published "Cometa" asked the central question: Do comets move in obedience to the same laws that control planetary motion?

Based on a rereading of Kepler's laws on planetary motion, Newton accepted this possibility. Comets can have curved orbits, elliptical, like the planets. Comets, too, can be part of the force called gravity. They can join the earth, the moon, the planets in a general principle of universal motion. In fact, there was room in Newton's mind for a whole universe. He now put aside his work on optics and pulled out some preliminary calculations. Within a few days, he reversed himself on the "two comet theory" of 1680.

It was one comet after all. And Mr. Halley's was another. Each comet apparition represented one orbit around the sun, a repeat performance. And with gravity as its moving force, its return could be predicted with the same ease as that used to track the path of Venus.

The Royal Society, a 20-year-old, private body of Europe's top scientists, was the official clearinghouse on empirical truth. Its motto Nullius in Verba, means "take no one's word for it." Theories, even from esteemed mathematicians, have the weight of air without incontestable proof. And proof was what the young Halley came to Cambridge in 1684 to get from Newton. Yes, the professor agreed, he would reassemble the numbers, rework his formulas on gravitational motion. Halley waited three months.

It was four years almost to the day that Edmund Halley presented to the Fellows of the Royal Society Newton's nine-page work "On the Motion of Orbiting Bodies," the now famous De Motu. Here at last was quantifying proof of the laws of motion. The world had a general of dynamics powered by the verified law of



HALLEY

universal gravitation. A light in the sky illuminated a theory and gave birth to the most brilliant rediscovery in western thought: that the universe is measurable, knowable. Terrestrial as well as celestial dynamics exist by the same ground rules. And the heavens, as distant as they are, operate not in mystery, but in harmony with man's mind. It was Edmund Halley who financed the publication of Newton's monumental Principia.

Halley waited twenty-three more years to match the master's boldness with a prediction of his own: in 1758 the comet of 1682 would return. This time, however, it was a prediction unlike any before it. It had the backing of Isaac Newton, and was more like a promise.

Neither man witnessed the 1758 apparition of "Halley's" comet, but sure enough the dawn sky that winter showed a new visitor, a vagabond tribute to two bold adventurers. Halley's comet came as expected, as if Halley's and Newton's view of the universe commanded its presence. As a result, when the comet next appears in 2062, no ruler need tremble on his throne and no one need wonder what all the fuss is about. It will just be one lucky generation's reminder that Sir Isaac's universe still holds true.

THE RETURN OF HALLEY'S COMET

During Christmas 1984, a team of astronomers spent the holiday season hunting Halley's Comet. This legendary celestial nomad returns to Earth's vicinity every 76 years, as if in rhythm with the average human life span. In late 1984 the comet was still beyond the orbit of Jupiter, and so faint that few telescopes on Earth could detect it. But several astronomical sleuths were at the controls of the huge Canada-France-Hawaii Telescope (CFHT) perched atop the 4200-metre-high summit of Mauna Kea, Hawaii—NRC's (Canada) Ian Halliday and Chris Aikman, and Bruce Golberg of the Jet Propulsion Laboratory, Pasadena, California. Towering above nearly half the Earth's atmosphere, the peak of Mauna Kea is considered by many to be the premier astronomical site on this planet.

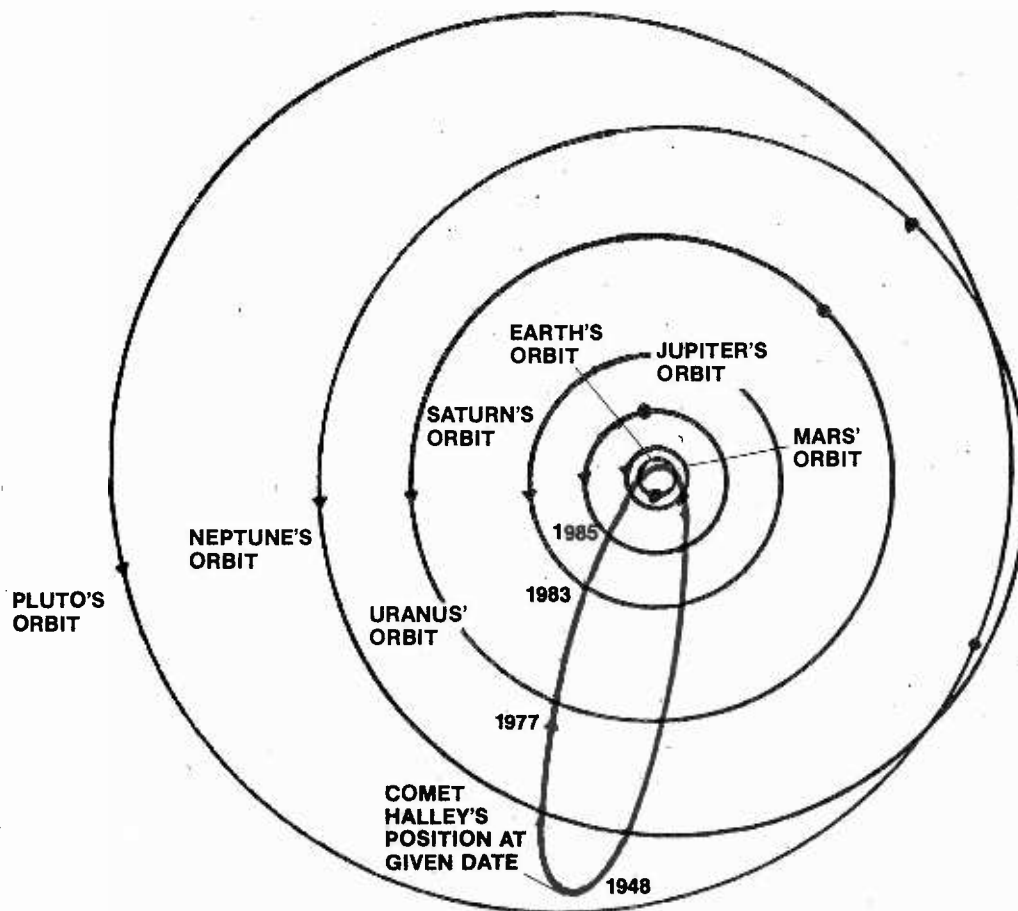

Fig. 1. Here's a bird's eye view (if a bird could fly that high) of Halley's Comet travels with the most recent travel dated.

The comet seekers did not come away dissatisfied. Using an ultra-sensitive electronic recorder called a *charge-coupled device*, or CCD, they not only recorded the image of Halley's Comet but observed it with three narrow-band color filters for an initial reading on its composition. They estimate that the comet was less than one-millionth the brightness of the faintest visible star.

By late November of 1985 it was expected to be seven times closer and more than a million times brighter than it was a year before, possibly reaching the threshold of naked-eye visibility. Although it will never achieve the prominence it had in the skies of 1910, scientific researchers around the world have made the best of circumstances by mounting an unprecedented cometary assault that included five spacecraft that have now rendezvoused with Halley in March 1986. The combined results of spacecraft and Earth-based explorations could reveal more about Halley—and comets in general—in the course of the this year, than has been accumulated since the invention of the telescope.

While in California...

Halley's comet has also been detected by the five-meter telescope on Mount Palomar, California. It was outside the orbit of Saturn. See Fig. 1.

The Palomar telescope has detected a faint point of light of 24th magnitude, equivalent to an object with a cross-section of a few square kilometers. If it could resolve detail, all there would be to see now, so it is thought, would be a lump of dirty snow which has been gathered together into a rough ball two kilometers across and frozen hard. There is no coma, or flowing tail, as in the familiar picture of a comet. At the end of 1985, it had emerged from a 76-year hibernation in the deep cold of outer space and develop its coma and tail for a brief reign as queen of our skies. The warmth of the Sun's rays will bring it to life by evaporating ice from the surface.

The comet is more spectacular than a snowball melting in winter sunshine because it evaporates in the emptiness of space where the gas molecules fluoresce in sunlight, react chemically with each other and become charged and respond to the electric and magnetic fields that permeate interplanetary space. All these processes help to shape the comet into the form we know. We see the gas cloud and the dust it carries away with it; the dirty snowball at its center cannot be seen inside the bright gas cloud. Gas molecules leaving the surface react with other molecules, absorb solar photons and then emit them at their own characteristic wavelengths.

The most common species identified in the

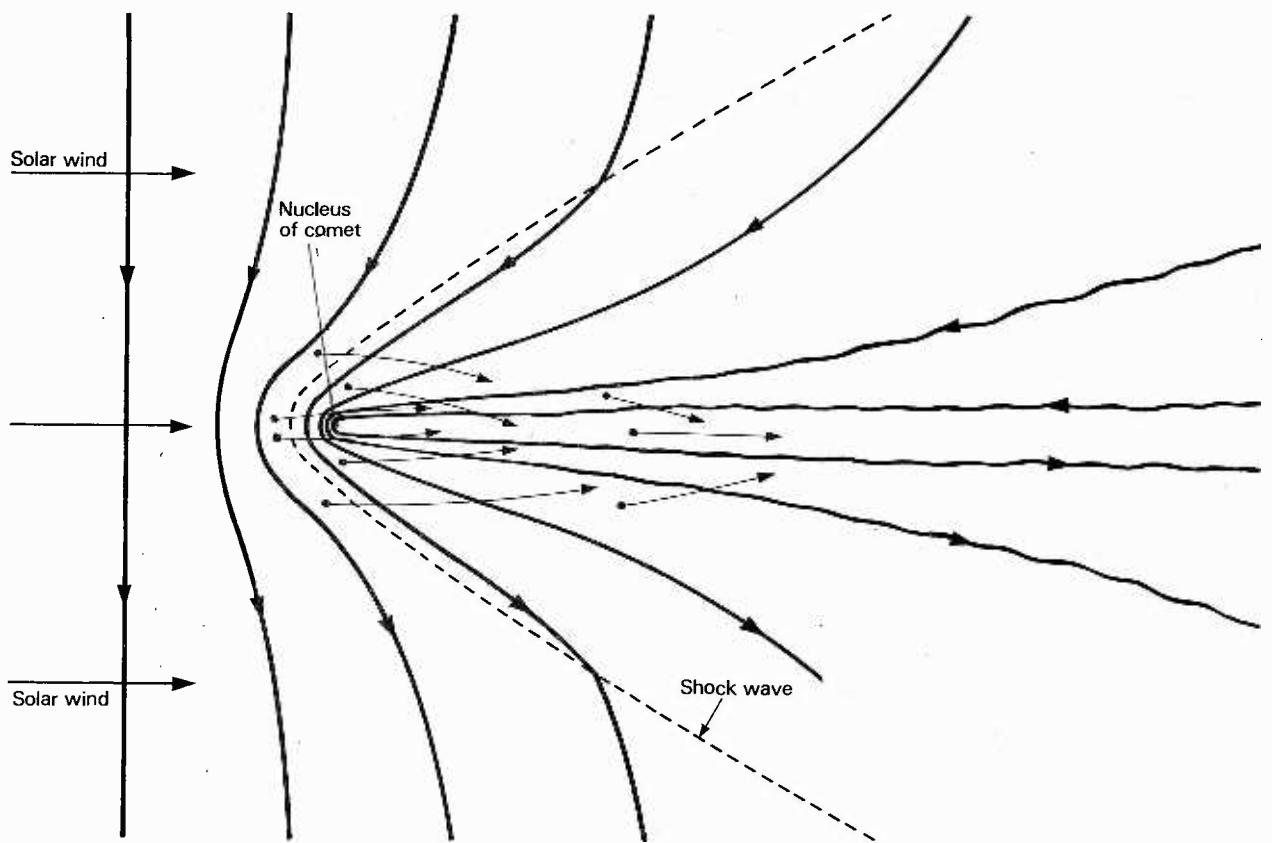

Fig. 2. Interplanetary magnetic field lines are held in slow-moving plasma in the head of the comet while the ends are carried downstream by the solar wind to form the plasma tail. Arrows show the direction in which new ions move after being created at the points marked by dots.

cometary spectrum are the radicals OH, O, H, CN and C₂ which cannot exist in the solid state and, therefore, could not have been evaporated from the nucleus. They must be the daughters, produced in photochemical reactions, of unseen parent molecules released from the nucleus. The two most likely parent molecules are water and carbon dioxide. Neither has emission lines at visible or ultra-violet wavelengths in the neutral state, so they cannot be detected directly from Earth. There must also be other parent molecules to account for the presence of nitrogen and other complex compounds.

Magnetic Field

Once the molecules emerge from this chemical soup some tens of kilometers thick, there is nothing to stop them drifting away into space unless they become ionized. When they do, the loss of an electron and the acquisition of a net positive electrical charge dramatically changes their view of interplanetary space. What seemed to be a vacuum is suddenly found to contain a plasma, a gas with equal numbers of positive and negative charged particles whose behavior can be visualized by imagining that magnetic field lines are frozen into it. See Fig. 2. The field may be stretched or twisted, but they retain their identity and move with the plasma.

The interplanetary plasma is called the solar wind,

because it blows away from the Sun at more than 400 km/s. The positive particles are protons and alpha particles, the negative ones electrons. Their density is too low to obstruct the flow of neutral molecules, but their electric and magnetic fields fill all space.

Cometary molecules are ionized by exchanging charge with solar-wind protons and by sunlight. When the electric field picks up a new ion it sweeps it along with the solar wind. This additional mass in the flow has to be given momentum and energy by the solar wind, which is thereby slowed down. Now ions have an effect out of proportion to their number because they are much more massive than the solar-wind ions. The retardation is so sudden near the comet that a sonic blow shock wave is formed.

The cumulative effect of the mass-loading is greatest on the plasma in the Sun-comet line upstream from the comet, where the plasma is retarded most. Because the distant ends of field lines continue to travel at the full solar wind speed, magnetic-field lines become wrapped around the head of the comet, as shown in Fig. 1; they are dragged downstream to form the filamentary plasma tail, made visible by the characteristic fluorescent emissions of those cometary ions among which H₂O⁺, CO₂⁺, CO⁺, N₂⁺ and OH⁺ have been found.

Some comets have a second tail, quite different from

the first, made of dust liberated from the ice as it evaporates. Puffs of escaping gas enable the dust particles to overcome the weak gravitational attraction of the comet and escape into space. They continue to orbit as the comet does, but are pushed away from the Sun by the pressure of sunlight scattering off their surface. The dust tail is therefore directed away from the Sun, but may become curved owing to the orbital angular velocity of the particles decreasing as their distance from the Sun increases. Because the tail is illuminated by the scattered sunlight, it appears white and reveals nothing about its composition. The dust particles are believed to have a vast range of sizes from less than 10-15 micrograms, up to about one gram.

Important Clues.

The origin of comets is still a mystery. Some scientists believe that there is a large cloud of comets orbiting in the outer parts of the solar system, tens of thousands of astronomical units (1 AU is the distance from Earth to Sun) from the Sun. Occasionally one is deflected into the inner solar system by the gravitational perturbation of nearby stars. The material of comets could have come recently, in terms of astronomical time, from interstellar space or be part of the material from which the solar system was formed five billion years ago. If the latter, the gas and dust released by solar heating is especially interesting because it has been kept in a pristine state ever since it was formed, frozen hard inside a comet. Whether this is eventually found to be true or not, the chemical composition of a comet must provide important clues about its origin and about the matter in the outer reaches of the solar system.

The only way to find out if our model of the comet's structure is correct, and to identify its chemical composition, is to make scientific observations inside

the coma. When Halley's comet next appears it will provide an excellent opportunity to do so, because it is by far the largest comet (measured by the rate at which it produces gas) with an accurately predictable orbit, making it possible to plan a space mission in time to meet the comet. Three agencies are now building the five spacecraft which will make the journey in 1986, namely the European Space Agency (one), and the space authorities of the USSR (two) and Japan (two). The European Space Agency has eleven member states. Its spacecraft, named Giotto after an Italian painter who included an accurate representation of Halley's comet in a painting of the Nativity of Christ, is being built by a consortium of industrial companies led by British Aerospace.

Meeting Point.

Sending a spacecraft to the comet poses special problems. The orbits of the Earth and the comet are shown in Fig. 3; the spacecraft must be placed in a third orbit which starts at the Earth and intersects the comet's orbit at the right time, using the least amount of rocket fuel so that the spacecraft can carry the largest possible collection of instruments. This requirement restricts the spacecraft to orbits lying in the ecliptic plane. The orbital plane of the comet is inclined at 165 degrees to the ecliptic, so the craft can meet the comet only at one of the two crossing points.

All the missions aim to meet the comet at the crossing after perihelion when it will be more active. Giotto must be launched within a short period of two weeks at the beginning of July 1985 if it is to reach the comet on time. The next problem is to find the tiny, unseen nucleus—if it exists. We can only assume that it is near the center of the bright coma, which is 100,000 km across, has fuzzy edges and is not always symmetrical. This makes aiming difficult and limits the accuracy with which the comet orbit can be tracked

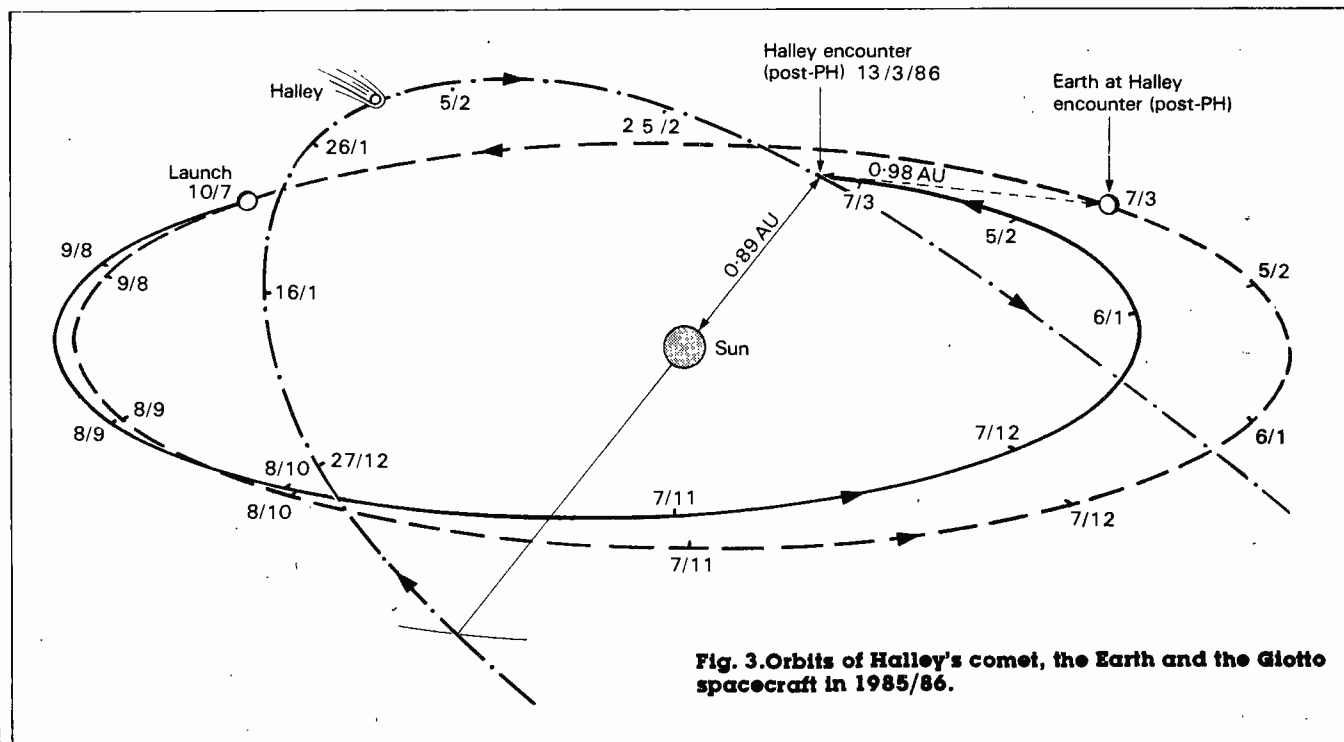

Fig. 3. Orbits of Halley's comet, the Earth and the Giotto spacecraft in 1985/86.

and predicted, for it is the nucleus that is subject to the gravitational forces, not the coma.

The mission controllers will take advantage of all the observations of the comet being made from the Earth and from the four spacecraft approaching the comet, but the probable error is estimated to be greater than 500 km.

As it approaches the nucleus, the spacecraft will run into another big problem. The relative velocity of the two bodies is extremely high, because they orbit the Sun in almost opposite directions, so tiny particles of dust drifting slowly away from the comet appear to the spacecraft to be moving directly towards it at the colossal speed of 79 km/s. A flake of dust weighing no more than a couple of postage stamps could hit the spacecraft with the same force as a bullet fired from a high-speed rifle.

Arranging to protect against such particles, which could rip out the heart of the spacecraft, is simplified by the fact that they will arrive parallel to the relative velocity vector. The spacecraft will be oriented with its spin axis pointing the same way and will carry a dust shield on the end facing the comet. Particles up to 10^{-7} gram should make a crater in the aluminum of the front shield. Larger ones may be expected to penetrate its 1 mm thickness, becoming heated to temperatures of tens of thousands of degrees and thereby vaporized by dissipation of their kinetic energy. The cloud of hot vapor spreads out and hits the rear shield, 12mm thick, made of several layers of plastic and placed 24 cm behind the front shield.

In combination, the two shields provide more protection than a single shield of the same weight and should be able to withstand the impact of a particle with a mass of up to 100 milligrams before the rear shield is penetrated and the instruments behind it are seriously damaged. Such a blow, if not taken on the spin axis, will also tilt the spacecraft causing the Earth to lose contact with the narrow radio beam bringing all the scientific information back. By the time communications could be established again the encounter would be over.

The probability of such an impact is estimated, for spacecraft passing the nucleus at a distance of 500 km, to be 90 per cent but it decreases sharply as the encounter distance increases. Estimates are based on observations of the dust tail but they are so uncertain, particularly for the large masses, that the real risk could be quite different. The mission is planned on the assumption that it will be brought to an end by such an event.

International Groups

Each of the ten scientific instruments is the responsibility of a principal investigator from a European research institution leading an international group of scientists. Two of the principal investigators are British; the others are from Federal Germany, France, Switzerland and Ireland. One of the instruments is a camera with a difficult task of taking a picture of a very rapidly-moving object from a rotating platform. It takes one picture in every rotation and selects just the portion containing the nucleus to transmit back to Earth. Only in the last few pictures will the nucleus appear large enough for details of its surface to be resolved.

Chemical composition of the comet will be measured by a group of three different mass spectrometers. The first looks at neutral molecules and radicals and the second at positively-charged molecules and radicals. Both instruments use magnetic and electric field analysis to separate the different types of particle. The third spectrometer analyses the composition of dust particles which vaporize when they strike a gold target. To find out the mass distribution of the constituent atoms and molecules, their time of arrival at a detector after being accelerated through a constant electric field will be recorded. By comparing the measured distribution with the atomic abundance in known minerals, the mineral type of the particle can be identified.

Two instruments are designed to observe the dust tail: one will measure the amount of light scattered by dust particles in various wavelength bands; the other, from the University of Kent, in England will then record the size of impacts on the dust shield, its aim being to discover the size distribution of the particles.

The final group of instruments is designed to study the interaction between the solar wind and the ionized cometary particles in the plasma tail. It includes a magnetometer, analysers to find the velocity distribution of positive ions and electrons, and a detector for the high-energy charged particles. University College, London, is responsible for the positive-ion analyser.

One big scientific problem to do with all the instruments lies in making sure that their results are not affected by the spacecraft itself. For example, instruments that have to be exposed will be damaged by the impact of dust and neutral molecules, both of which produce secondary ions and electrons on the spacecraft and within instruments. Emission of such secondary particles may be expected to charge the spacecraft to a high voltage, so preventing some cometary charged particles reaching the instruments and building up a background of unwanted particles inside the instruments. Some of the material removed from the spacecraft by impact could find its way into mass spectrometers and contaminate the cometary spectra. So, the instruments have been designed either to eliminate the known sources of contamination, or to make their effects easily recognizable. The unexpected sources must be allowed for by embodying enough cross-checks in the information from each instrument, and the collection of instruments taken together, to be able to verify the accuracy of the results.

The four spacecraft will complete another step in the dramatic exploration of the solar system which has been going on during the past ten years. Each visit to another planet, or moon, has opened our eyes to new wonders, given us a better understanding of our own planet and provided a new perspective of its position in the cosmos. We can confidently expect that the messages sent back by the travellers to Halley's comet will do the same.

Some History

Halley's Comet appeared in the sky above England in 1066 when William the Conqueror defeated King Harold at the Battle of Hastings. Exactly a millenium earlier in 66 A.D., the Jewish historian Flavius Josephus described Halley as "a broadsword-shaped

star" over Jerusalem at the time that city was under siege by Rome. A few orbits later, it was again Halley that showed itself in Earthly skies while the Romans defeated Attila the Hun at the battle of Chalons in 451 A.D. There aren't enough comets to account for all significant historical events; but once the tradition was established, there was no stopping it. At the death of Charlemagne in 814 A.D., for example, a bright comet was duly reported to have graced the skies, although the Chinese, the most reliable comet-watchers in the world before the Renaissance, reported nothing unusual in the sky at the time. (Chinese chronicles document sightings of Halley's Comet at least as far back as 242 B.C.)

Apart from Halley, some reasonably bright comet is visible about once a decade. It was one of these comets seen in 1577 that caught the attention of the Danish astronomer Tycho Brahe. His observations of it using accurate sighting instruments (the telescope hadn't been invented yet) proved by simple triangulation that comets were true celestial objects, located well beyond the moon. Until then, Aristotle's pronouncement that comets were "atmospheric phenomena" had been accepted as gospel. So entrenched was this idea that even a generation later, Galileo remained convinced that vapors from sea and earth collected into cometary forms, possibly just above the clouds.

The ghost of this old concept still exists today, but for a different reason. Photographs that reveal streaming cometary tails give the mistaken impression that comets are hurtling across the sky, and that their tails are flung out by the disintegration of their bodies, perhaps due to friction with the atmosphere.

Halley was first.

In 1704, Edmond Halley first deduced from historical records that the comet which now bears his name has a 76-year orbit that carries it from beyond the orbit of Neptune to inside that of Venus. Only during two of those 76 years is it close enough to Earth for solar emissions to cook up a coma dense enough for reasonable visibility by telescope or, less certainly, the naked eye.

As Halley's Comet continues to hurtle in the general direction of Earth and sun, astronomers around the globe are readying their equipment for intensive investigations beginning early this autumn and continuing through next spring. Larger telescopes will track the comet well into 1987. Assisting the professional researchers in an army of enthusiastic amateur astronomers, whose visual descriptions of the comet will provide valuable benchmarks for comparison with historical documentation of the comet's previous appearances.

After Halley retreats, collecting and digesting the observations of hundreds of professional and thousands of amateur astronomers would be a logistical nightmare. In fact, that's the swamp where cometologists found themselves after Halley's last visit. Determined not to repeat that mistake, modern astronomers heeded a recent suggestion of the U.S. National Aeronautics and Space Administration (NASA), and organized this visit's International Halley Watch (IHW). Last January, at a meeting in Pasadena, California, IHW elected NRC's Ian Halliday chairman

of its IHW Steering Group of 25 comet specialists, including scientists from England, the U.S., the U.S.S.R., China, India, and several other countries. IHW is subdivided into eight disciplines, each with its team of specialists, for such studies as large-scale structures, radio, and photometry.

What in the World?

Because the United States is not sending a vehicle to Halley, the Russians agreed to carry an American dust-measuring device. In return, NASA will use some of its sophisticated deep-space tracking dishes to monitor the Vegas while they are out of range of Soviet equipment. Television cameras aboard both spacecraft will provide our first close-up views of a comet nucleus—perhaps the most important component of the mission.

As a warm-up for the Halley encounters, NASA has diverted an old but active spacecraft in solar orbit, renamed the International Cometary Explorer, to pass through the tail of a small comet known as Giacobini-Zinner on September 11 last year. If Cometary Explorer meets more dust than now predicted, there may be revisions to the Vega and Giotto flight plans. For their part, The Japanese aren't taking any chances. Their two small spacecraft are staying well back to measure cometary gases and their interaction with the solar wind. Another NASA satellite, in orbit around Venus, will turn its instruments toward Halley for several weeks while the comet is closer to Venus than to Earth.

Meanwhile, the U.S. Space Shuttle will deploy a special Halley-watching satellite into Earth orbit to observe the comet from above Earth's atmosphere. On another Shuttle mission, four payload specialists will aim a battery of cameras and other exotic instruments towards the celestial guest.

Finally, there are astronomers who will be watching for meteors torn off from Halley. Twice a year, the Earth passes through particles spread around Halley's orbit.

These two meteor showers, known as the Eta Aquarids (early May) and Orionids (mid-October) to increase much just because the parent comet is nearby.

We never get any closer than about seven millions kilometres to the present orbit of Halley. The meteors we see this year were shed by the comet centuries ago, and have only now worked their way out to our position. The Earth is, in effect a sampling probe cutting through the ribbon-like Halley meteor stream.

In the years ahead, when this year's rich scientific feast of Halley's Comet has been digested, we may know more not only about comets, but about ourselves as well. Due to lengthy residence in the cosmic ice-box beyond the outer planets, comets are possibly the most primitive objects, in the solar system, unchanged since the origin of the sun and planets. It is known that these chunks of primordial ice contain abundant water and other simple compounds—perhaps, biologists suspect, the primary ingredients from which life emerged on Earth. Human curiosity about comets may thus be a natural reaction. ■

Grateful acknowledgement and appreciation is extended to the author of "A Tale of Two Comets", Steve Lowe, and "The Trinity Reporter", Trinity College, Hartford, Connecticut for permission to reprint parts of this story.

LATINO MUSICA DIPOLE

By Ed Noll

Radio listening is a compelling hobby and one that continues to grow in the U.S.A. A special interest for many is shortwave listening. Active SWL'ers also find hobbies within a hobby. One of special appeal to many, is listening to Latin music.

To enjoy music fully you need a strong locked-in signal. There is always a little or a lot of signal waver which is characteristic of shortwave propagation. You minimize its ill effects by trying to have a reasonably efficient antenna system that delivers a good signal to your receiver.

Proper receiver bandwidth is another consideration. If you must operate your receiver on a narrow band to avoid interference from a strong station on an adjacent frequency, some of your music quality (high frequencies) is lost. Sometimes a directional antenna can help a bit. Don't expect too much from shortwave signal reception on a sustained basis. Shortwave reception is not like receiving a strong local station. However, when signals come bounding through, enjoy the music fully. When propagation conditions are poor you must be satisfied with what you get. Often a bit of work and thought can improve your luck.

Dipole antennas recently have become more popular in preference to the usual hunk of wire with its spotty and indefinite results. The dipole is basically a single-band antenna. However, mediocre to acceptable results are obtained on other bands. By compromising dipole dimensions you can often smooth its performance over several bands.

The dipole is also directional to a degree. It has a very wide reception angle broadside and near-broadside to its plane as shown in Fig. 1. There is a narrow region of

rather poor reception that is in line with the dipole wires as shown. When you erect your dipole try to position these minimums at angles from which few stations are receivable.

Associated with Fig. 1 are the prescribed lengths of each quarter-wave segment of a dipole for shortwave bands 19, 25, 31, 49 and 60 meters. There are five very active shortwave broadcast bands of special interest because of the Latin music programs that can be received.

Table #1, lists some of the more reliable stations I monitor for Latin music. All except one are on the air during the evening hours. Spanish station on 15535 is a good daytime bet. There are other stations on the air too and you must search on your own because of propagation conditions, schedules, and frequencies changes.

Remember there is time sharing on the various frequencies. The station you tune in on one frequency at 6PM may not be the same one you hear at 9PM. At times there is more than one station on the same frequency. The UTC times given indicate when that particular station transmits English programming for North America. By tuning in at these times you can learn more about that station's activities. However, the language barrier should be no deterrent to enjoying Latin music.

On a long-term basis the signals from Spanish Foreign Radio are most reliable throughout the year. Usually you can find one or more Spanish stations coming through well during regular day and nighttime listening hours. Evening signals from the stronger South American stations on the 19,25 and 31 meter

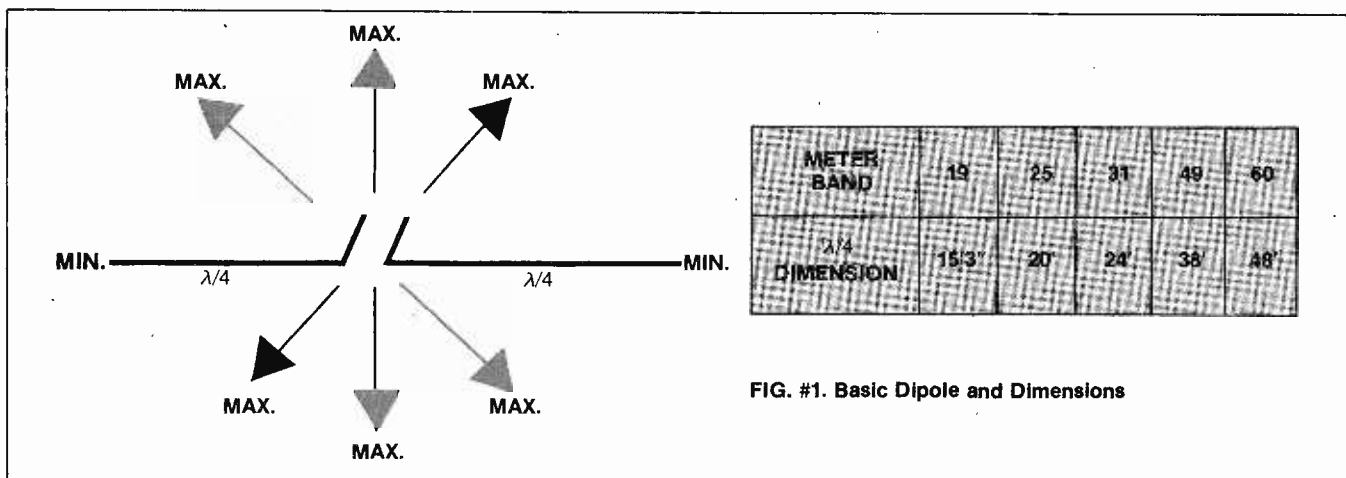
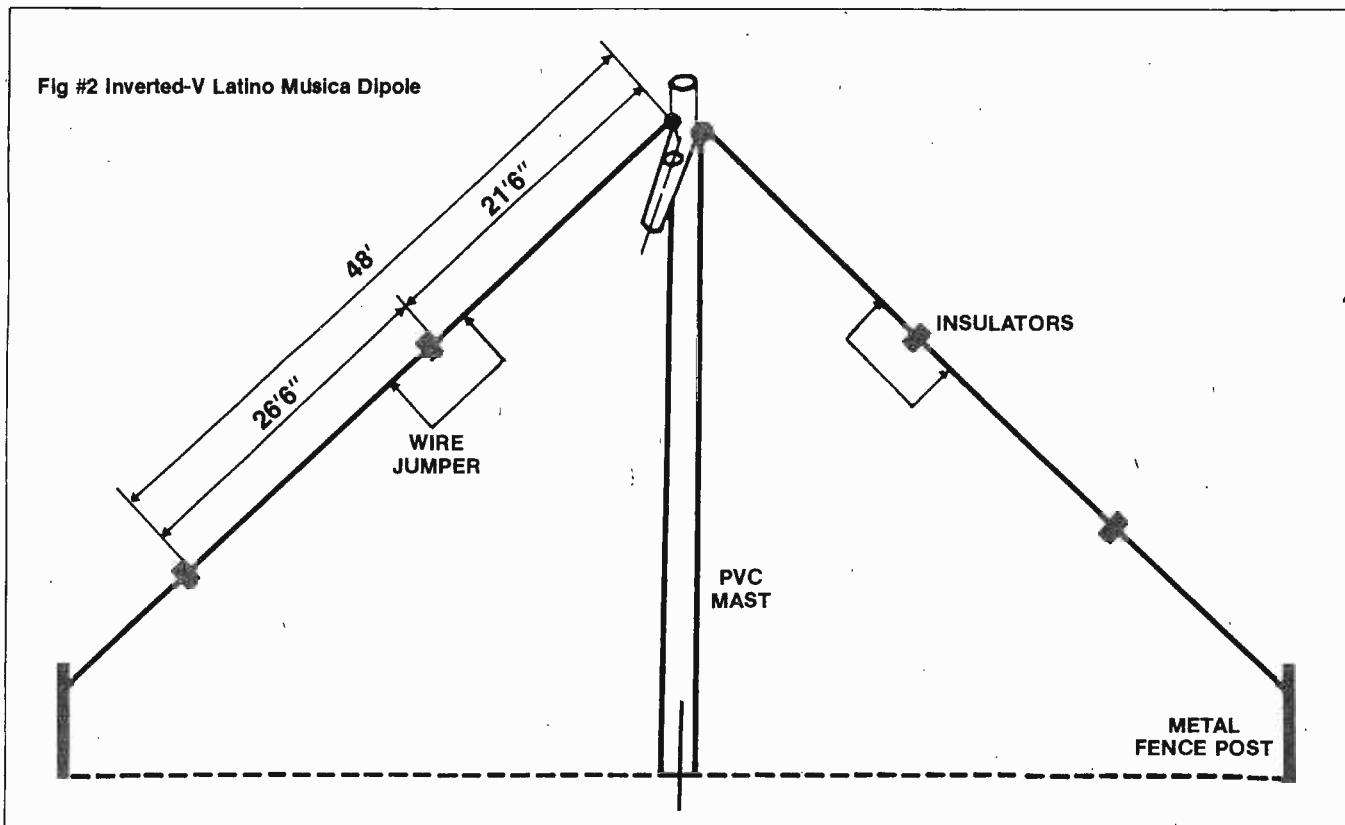

FIG. #1. Basic Dipole and Dimensions

Fig #2 Inverted-V Latino Música Dipole



bands are next in reliability. However, propagation is a very variable quantity and favors these signals on a seasonal basis. They are often quite poor during the winter months. There are many Latin American signals broadcasting on the 49 and 60 meter bands. Unfortunately, their power levels are low and interfering signals are troublesome, to say the least. You must be much more patient. Enjoy the Latin music when the conditions are just right. Sometimes you will be rewarded with the sounds of flutes, harps and other string instruments because the music from the Andean countries of South America is of both Spanish and Indian heritage.

A SPECIAL DIPOLE

The dipole of Fig. #2 is a cheap and simple compromise dipole that favors these five bands. An inverted-V type was chosen because it can be loosened readily and permits you to open and close a pair of jumpers located at the first pair of insulators if you wish to favor two or three of the bands a bit more. Also the directional pattern can be oriented with ease by using a second set of ground stakes that will permit you to move the antenna around to favor either Spain or Central and South America. This may be only necessary when there is some station or program of special interest you wish to receive at its very best.

The length of each leg between the point of transmission line attachment and the first insulator when the jumper is open is a compromise length that favors the 25 and 31 meter bands. Jumpers can be easily reached by freeing each leg one at a time. When the two insulator jumpers are closed, the overall length of each leg is approximately 48 feet. In this mode of operation the antenna favors the 49 and 60 meter bands. This overall element length corresponds to an

COUNTRY	MHZ	UTC
ARGENTINA	15.345	0100
BRAZIL	11.780	—
BRAZIL	15.290	0200
CHILE	9.630	—
CHILE	15.140	—
COLOMBIA	9.635	—
CUBA	11.760	—
CUBA	15.125	—
PORTUGAL	6.060	0300
PORTUGAL	11.925	0300
SPAIN	9.630	0000
SPAIN	11.880	0000
SPAIN	15.535	—
VENEZUELA	9.540	—
DOMINICAN REPUBLIC	11.700	—

Table #1: Some of the Stronger Latin Music Stations

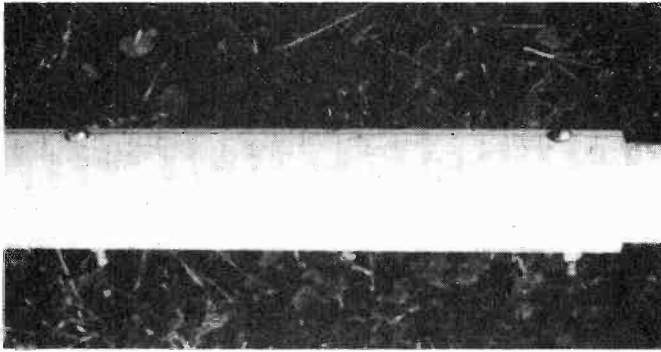

Fig #3 Bolted PVC Piping

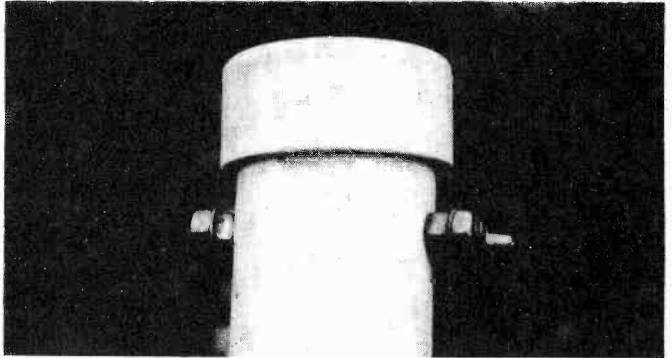

Fig #4 Terminals and Antenna Vite at Top of Mast. Coax Connections are beneath Cap

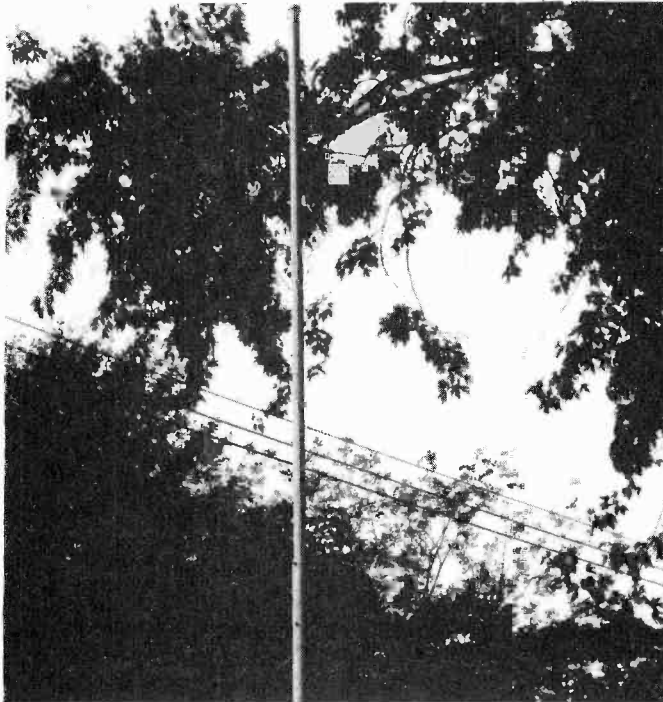

Fig #5 Erected Mast

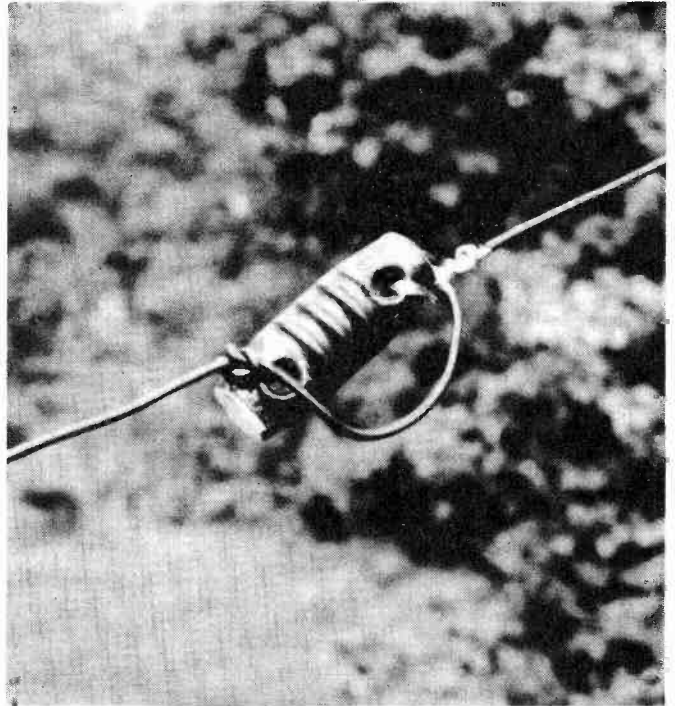

Fig #6 Jumper Closed

electrical length of $3/4$ wavelength on the 19 meter band. Thus good results are also obtained on this band with the jumpers closed.

An easy-to-handle and low-cost mast can be constructed of telescoping sections of PVC pipe. For example, a $1\frac{1}{2}$ inch ID 10-foot section can be telescoped $1\frac{1}{2}$ foot into a 10 foot, 2-inch ID section. The two masts are then bolted together as shown in Fig. #3. Two holes are drilled into the very top of the top section for inserting nut and bolt terminals. Transmission line innerconductor and outer braid are connected to the two terminal bolts inside of the mast using solder rings. The transmission line must be first fed up through the mast by way of a hole drilled at about the half-way point of the bottom mast section. Antenna wire using similar eye rings attaches to the terminal bolts exterior to the mast as shown in Fig. #4.

At the position where the mast is to be erected a metal fence post is driven into the ground. One person then can easily lift the mast and set it over the metal fence post. This is all the support needed by a two-section mast. Be certain to drive the fence post straight into the ground. Additional mast support is supplied by the two antenna wires when they are stretched out into

position. The erected mast is shown in Fig #5.

Additional mast height can be obtained by using a 5-foot length of 1-inch ID PVC piping and dropping it about 1 and $\frac{1}{2}$ feet into the $1\frac{1}{2}$ inch ID section. This arrangement would give you an apex height in excess of 20 feet.

The jumper arrangement used in our experimental modified dipole is shown in Fig. #6. A length of the antenna wire was first knotted at the insulator hole but made long enough to reach around the insulator for connection to the second piece of antenna wire for each element. Consequently it can be looped around to provide a jumped wire across the insulator or disconnected for the open mode of operation. If you prefer, a connector of the clamp type can be attached to the wire. The same type of metal fence post that supported the mast was used to tie-down the ends of the antenna wires. A good quality rope is used between the end insulator of each leg its metal fence post.

This antenna will also perform on other bands over the shortwave frequency spectrum. However, you can depend on good results for the five bands indicated.

Enjoy your shortwave listening hobby and don't overlook the good music. ■

THE JUNK BOX SPECIAL

Power your projects, spend pennies for parts.

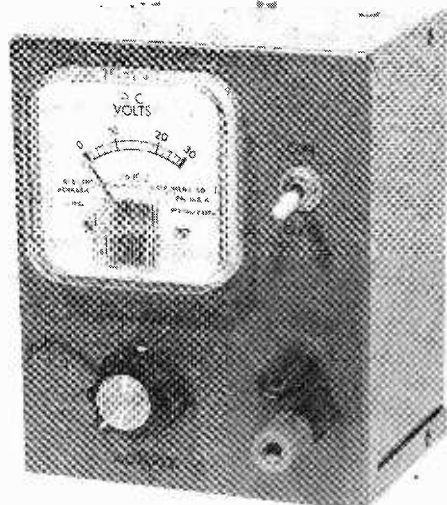

Between 555 timers, TTL, CMOS, opamps, and run of the mill transistor projects, the average experimenter is often faced with the need for a regulated power supply with a range of about 5 to 15 volts—just to try out a breadboard project. If you've priced any regulated supplies lately you know they don't come cheap. Maybe, just maybe, you might get one for \$30 or \$35.

With a little careful shopping, a reasonably stocked junk box and one or two "brand new" components you can throw together a regulated supply costing less than \$10 that will handle most of your experimenter power supply requirements. One of these Junk Box Specials is shown in the photographs and schematic. The range of this model is 5 to 15 volts DC at currents up to 1 ampere. One of the common, 3-terminal regulators which are now flooding the surplus market provides everything in the way of regulation. Depending on the source, the regulator will cost you about \$1; price often includes an insulated mounting kit.

5 to 15 volts from one 3-terminal regulator? Correct. If regulator IC1's collector terminal is connected to a voltage divider across the output—R1 and R2—the output voltage will be that at the junction plus the voltage rating of the regulator, which in this instance is 5 volts. So, when potentiometer R2 is adjusted so its wiper is grounded the power supply's output is that of the regulator, 5 volts—perfect for TTL projects. As R2 is advanced, increasing the resistance from IC1's collector to ground, the voltage output increases.

Getting the parts. There are plenty of parts around to build this supply for under \$10. If you go out and round up "all new" components the cost is likely to go well over \$30, so forget about new parts. Power transformer T1 can be 18 volts at 1 ampere (or rated at higher current, though the supply's maximum output is 1 ampere), or 36 volts center-taped at 1 ampere or more. Both the 18-volt and 36-volt transformers are glutting the surplus market. If you get an 18 volt transformer use the bridge rectifier shown in the schematic. If you get a 36-volt center-taped transformer use the full-wave rectifier shown below the schematic. The diode

If you've had experience with assembly in tight quarters, you can shoe-horn the power supply into a standard 3×4×5-inch Minibox. If your soldering iron is so big it burns adjacent wires when you make a connection, use a larger size cabinet.

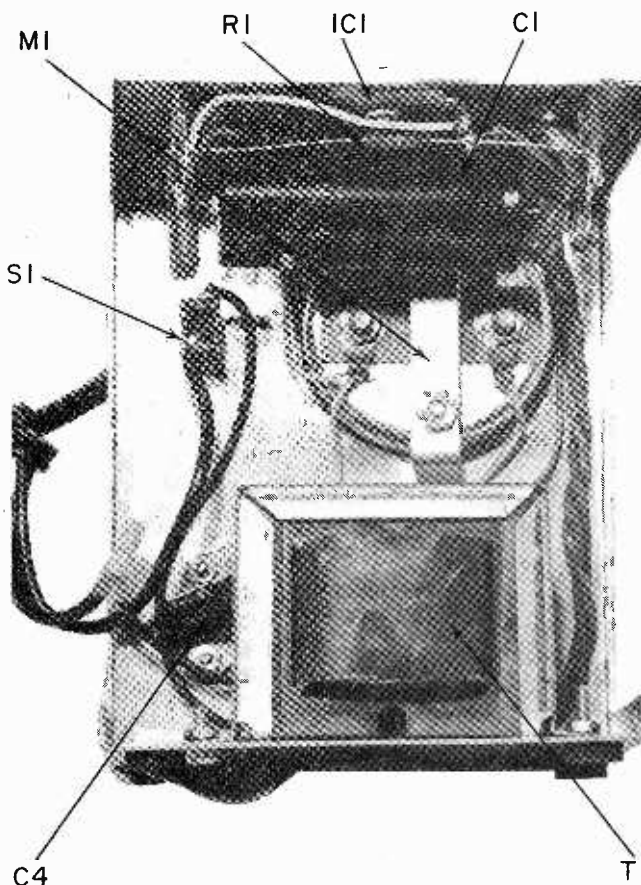

HOBBY DEPARTMENT

rectifiers SR1 through SR4, are type 1N4001, 1N4002, 1N4003, or 1N4004, which are also glutting the surplus market. Just to show you the savings possible, at the time this article is being prepared you can buy fifteen surplus 1N4001s for \$1. Just one single "general replacement" for the 1N4001 from a national supplier is selling for over 40-cents. Get the idea how to save costs on this project?

Capacitor C1 can be anything from 2000 to 4000 μF at 25 volts or higher. Look for an outfit selling surplus computer capacitors. If worse comes to worse you can get the value specified in the parts list in a Radio Shack store.

The 3-terminal, 5 volt regulator is another item easily found on the surplus market. With an adequate heat sink—such as the cabinet itself—the device can safely deliver 1 ampere. The unit shown in the photographs is a Motorola MC7805 (though you can substitute any similar type) obtained for \$2.50 from Circuit Specialists. We have seen similar devices from other manufacturers selling for \$1. The terminal B, C and E are indicated directly on the device or on the terminals—where they join the case. The collector (C) lead is connected to the IC's metal tab, and is normally grounded. Note that in this project, however, the

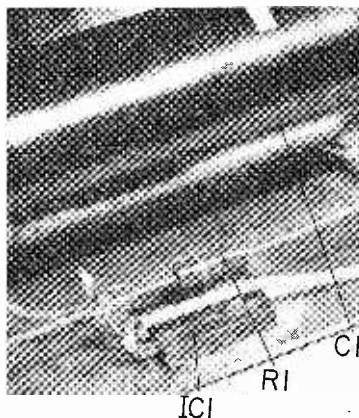

In order to handle a full ampere, the IC regulator must be heat sunk to the cabinet. Make certain the collector and its attached sink tab (the back of the package) is insulated from the cabinet. Use silicon grease to insure heat transfer from the IC to the cabinet.

collector terminal, and therefore the tab, is not grounded. You must use an insulated mounting kit consisting of a mica insulator and a shoulder washer. Place the insulator between the IC's body and the cabinet, or the tab and cabinet, and slip the shoulder washer into the opening (hole) in the body or tab. Pass the mounting screw from outside the cabinet through the mica washer, through the IC, and through the

(Continued on page 93)

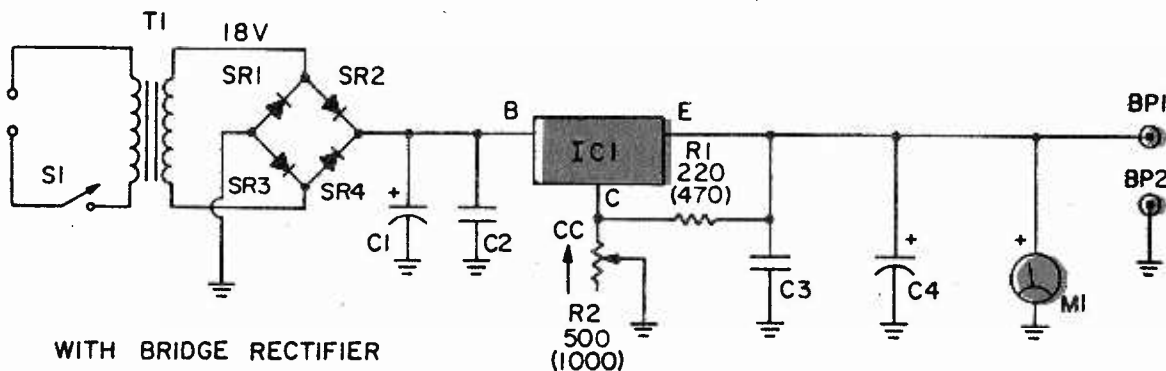

WITH BRIDGE RECTIFIER

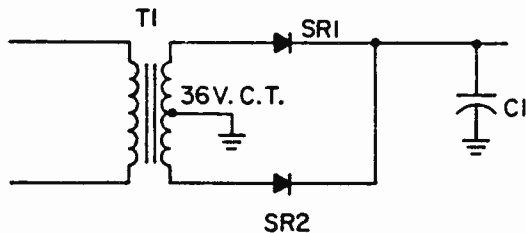

ALTERNATE FULL-WAVE RECTIFIER

Virtually any DC voltmeter that can display the range of 0 to 15 volts can be used. The surplus market is loaded with less-than-\$5 meters that are suitable if you don't mind a little extra-scale coverage.

PARTS LIST FOR JUNK BOX SPECIAL

- R1—220 or 470-ohms, 1/2 watt, 10% (see text)
- R2—Potentiometer, 5000 or 1000-ohms (see text)
- C1—3300- μF , 35-WVDC (see text) (Radio Shack 272-1021 or equivalent)
- C2, C3—0.1 μF Mylar
- C4—25- μF , 25-WVDC or higher
- M1—DC voltmeter (see text)
- IC1—Motorola MC7805, 5 volt 3-terminal regulator (see text)
- T1—Power transformer secondary, 1 ampere at 18 volts or 36 volts C.T. (see text)
- SR1—Silicon rectifiers (see text)
- S1—SPST switch
- BP1, BP2—5-way binding posts
- Misc.—Cabinet, terminals strips, etc.

QUARTZ CRYSTAL MAGIC

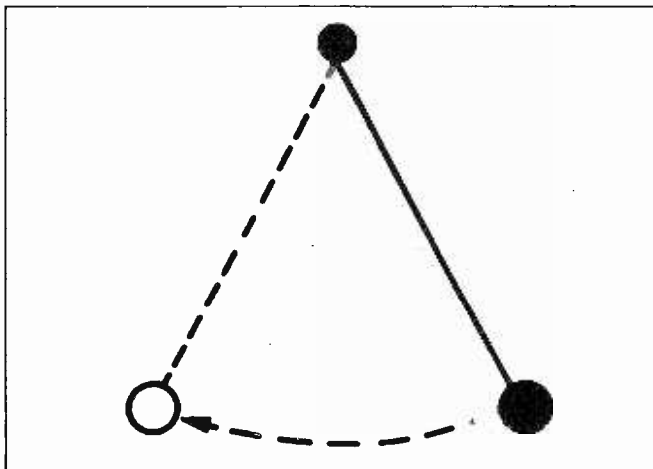

Fig. 1. A long pendulum swings at a rate determined by its length and weight at the end of the arm. To experiment at home, the arm should be made of light thread (no weight) and a small heavy mass (all the weight concentrated at one point).

Can you imagine the chaos on the AM broadcast band if transmitters drifted off frequency as much as those inexpensive table radios do? The broadcast station engineer has a tough job. He must keep his station carrier within 20 Hertz of its assigned frequency. How does he do it?

This is, of course, done with a little help from a very basic material, the quartz crystal and some supportive circuitry. The crystal is the single component that serves to fill a basic requirement for precision frequency control. Quartz crystals not only fix the frequency of radio transmitter carriers (from CB installations to multi-kilo-watt-broadcast installations,) but also establish the frequency of timing pulses in many modern computers. In addition, they can provide the exceptional selectivity required to generate and receive single-sideband signals in today's crowded radio spectrum. Yet this list merely touches upon the many uses of quartz crystals. No exhaustive list has even been compiled.

A Real Gem. This quiet controller is a substance surrounded by paradox. While quartz composes more than a third of the Earth's crust, it was one of the three most strategic minerals during World War II. And despite its plenitude, several semiprecious gems (including agate and onyx) are composed only of quartz.

Unfortunately, quartz exercises its control in only a relative manner. When it's misused, the control can easily be lost. For this reason, if you use it in any way—either in your CB rig, your ham station, or your SWL receiver—you should become acquainted with the way in which this quiet controller functions. Only then can you be sure of obtaining its maximum benefits.

What Is It? One of the best starting points for a study of quartz crystals is to examine quartz itself. The mineral, silicon dioxide (SiO_2), occurs in two broad groups of mineral forms: crystalline and non-crystalline. Only the large crystalline form of quartz is of use as a controller.

The crystalline group has many varieties, one of which is common sand. The variety which is used for control, however, is a large, single crystal, usually six-sided. The leading source of this type of quartz is Brazil. However, it also is found in Arkansas.

A property of crystalline quartz, the one which makes it of special use for control, is known as *piezoelectricity*. Many other crystals, both natural and synthetic, also have this property. However, none of them also have the hardness of quartz. To see why hardness and the piezoelectric property, when combined, make quartz so important, we must take a slight detour and briefly examine the idea of resonance and resonators.

Resonators and Resonance. As physicists developed the science of radio (the basis for modern electronics), they borrowed the acoustic notion of resonance and applied it to electrical circuits where it shapes electrical waves in a manner similar to an acoustic resonator. For instance, both coils and

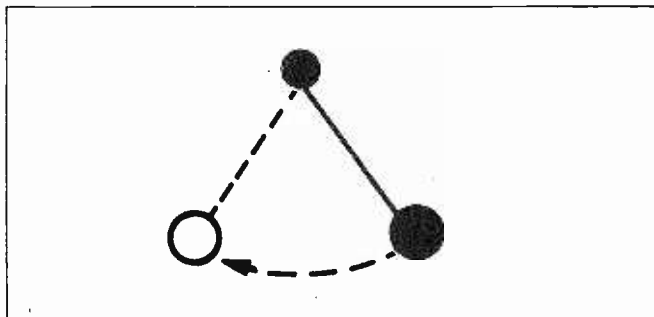

Fig. 2. A short pendulum swings at a faster rate no matter what the weight is. The heavier the weight, the longer the pendulum will swing at the faster rate.

capacitors store energy and can be connected as a resonator (more often termed a resonant circuit). When AC of appropriate frequency is applied to the resonator, special things happen.

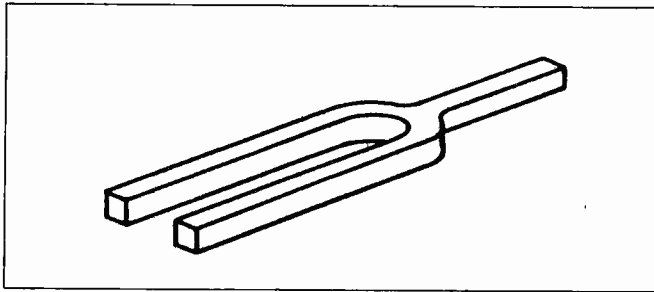

Fig. 3. The geometry of the tuning fork produces a continuous pure tone for a long time when struck gently. It is favored by piano tuners as a convenient way to carry a source of accurately-known tone or pitch.

Pendulum Demonstrates. The principle involved is identical to that of a pendulum, which is itself a resonator closely similar in operation to our quartz crystals. To try it you can hang a pendulum of any arbitrary length (Fig. 1), start it swinging, then time its *period*—one complete swing or cycle. The number of such swings accomplished in exactly one second is the *natural* or *resonant* frequency of the pendulum in cycles per second (hertz).

You can, by experiment, prove that the frequency at which the pendulum swings or oscillates is determined by the length of the pendulum. The shorter the pendulum (Fig. 2), the faster it swings (the greater the frequency). The weight of the pendulum has no effect on frequency, but has a marked effect upon the length of time the pendulum will swing after a single initial push in the atmosphere: the heavier the pendulum, the greater the number of cycles back and forth before it stops.

A Real Swinger. Once the pendulum begins to swing, very little effort is required to keep it swinging. Only a tiny push is needed each cycle, provided that the push is always applied just as the pendulum begins to move away from the pushing point. If the push is given too soon, it will interfere with the swinging and actually cause the swing to stop sooner than it would without added energy; while if too late, added push will have virtually no effect at all. It all becomes simple when you recall your last experience "pushing" a swing with a child on it!

It is this principle—a tiny push at exactly the right time interval—which makes a resonator sustain sound or alertating-current waves. You can prove it with the pendulum by first determining the resonant frequency of a pendulum, then stopping it so that it is completely still. A series of small pushes, delivered at the natural resonant frequency, (each too tiny to have more than a minute effect) will very rapidly cause the pendulum to swing to its full arc again. Pushes of the same strength at any other frequency will have or no effect.

The pendulum is an excellent control mechanism for regulating a clock to keep time to the second, since the resonant frequency of the pendulum can readily be adjusted to be precisely one cycle per second. However, for control of audio frequencies from tens of

Hertz (cycles-per-second) up to tens of thousands of cycles-per-second (kiloHertz), or for radio frequencies ranging up to hundreds of millions of cycles per second (megaHertz), the pendulum is too cumbersome a device.

The Tuning Fork. In the audio range, the equivalent of the pendulum is the tuning fork. This is an extremely elongated U-shaped piece of metal (Fig. 3), usually with a small handle at the base. When struck, it emits a single musical tone.

The operating principle is exactly the same as the pendulum. Each of the arms or tines of the fork corresponds to a pendulum arm. But here the arms are extremely short and much heavier in proportion to their size than the pendulum. (The shorter the arms of a tuning fork, the higher the resonant frequency in the audio range.) This greatly increased mass causes the arms of the tuning fork to oscillate much longer when struck.

Not all tuning forks operate precisely like pendulums. The pendulum principle is based on a *flexing* of the arm upon its long dimension. While this is the most common operation, the fork may flex along any dimension.

It's even possible for a single, solid resonator such as a tuning fork to flex along several dimensions at once. A main part of the design of a good tuning fork is to insure that only a single dimension flexes or, in the language of resonators, only a single mode is excited.

Area Too. There's no requirement that the resonator be a completely solid substance. A mass of air, suitably

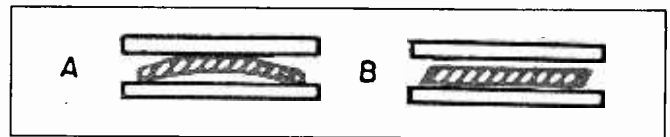

Fig. 4. Depending on how the crystal is cut or sliced from the mother crystal, some crystals warp or bend as in A and others shear as shown in B. Each of the many cuts have special characteristics.

enclosed, forms a resonator. This is the resonator that works on a classic guitar or violin. Here, single-mode operation is distinctly *not* desired. Instead, multiple-mode operation is encouraged so that all musical tones within the range of the instrument will be reinforced equally.

Now, with the principles of resonance firmly established, we can return to the quartz crystal and its operation.

Quartz Crystal as Resonators. Like the tuning fork or, for that matter, any sufficiently hard object, the quartz crystal is capable of oscillation when struck physically or in some other way excited.

But unlike the tuning fork, or indeed any other object except for certain extremely recent synthetic materials, the quartz crystal is not only sufficiently hard to oscillate at one or more resonant frequencies, but its piezoelectric.

Piezoelectricity. The piezoelectric property means simply that the crystal generates an electric voltage when physically stressed or, on the other hand will be physically deformed when subjected to a voltage (see Fig. 4). Other familiar objects making use of piezoelectricity include crystal and ceramic micro-

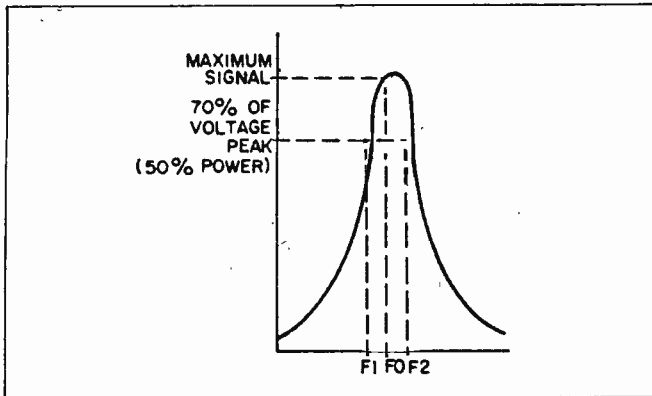

Fig. 5. Bandwidth characteristic of a typical tuned circuit shows the peak or maximum signal amplitude and the 70% voltage peak (50% power) points. This is the characteristic that determines overall selectivity.

phone elements and phonograph.

This virtually unique combination of properties (sufficient hardness for oscillation and piezoelectricity) found in quartz crystals, makes it possible to provide the initial push to the crystal by impressing a voltage across it. To provide the subsequent regular pushes, a voltage can be applied at appropriate instants.

Quality Factor. Almost any discussion of resonance and resonant circuits (or for that matter, inductance) eventually gets to a rather sticky subject labelled in the earliest days of radio as *quality factor* but now known universally as *Q*.

As used in radio an electronics, *Q* is usually defined by other means. Some of the definitions put forth at various times and places include:

- The ratio of resistance to reactance in a coil.
- The ratio of capacitive reactance in a resonant circuit to the load resistance.
- The impedance multiplication factor, and others even more confusingly worded.

All, however, come out in the end to be identical to the definitions cited above: The *Q* of a resonator is the ratio of the energy stored per cycle to the energy lost per cycle.

In a resonator, high *Q* is desirable. *Q* is a measure of this energy loss. The less energy lost, the greater the *Q* of the circuit.

Not so obvious (and rather difficult to prove without going into mathematics) are some of the other effects of *Q*. A resonant circuit is never completely selective; frequencies which are near resonance but not precisely equal to the resonant frequency pass through also!

An Interesting Fraction. The greater the *Q*, the narrower the band of frequencies which can affect the resonator. Specifically, the so-called half-power bandwidth (Fig. 5) of a resonator (that band in which signals are passed with half or more of the power

possessed by signals at the exact resonant frequency) is expressible by the fraction F_0/Q , where F_0 is the resonant frequency and *Q* is the circuit *Q*. Thus a 455 kHz resonant circuit with a *Q* of 100 will have a half-power bandwidth of 455/100 kHz, or 4.55 kHz. This relation is an approximation valid only for single-tuned circuits; more complex circuits are beyond this basic discussion.

The *Q* of Quartz Crystals. When we talk of the *Q* of conventional resonant circuits composed of coils and capacitors, a figure of 100 is usually taken as denoting very good performance and *Q* values above 300 are generally considered to be very rare.

The *Q* of a quartz crystal, however, is much higher. Values from 25,000 to 50,000 are not unheard of.

The extremely high *Q* makes the crystal a much more selective resonator than can be achieved with L-C circuitry. At 455 kHz, for example, the bandwidth will be between 10 and 20 Hertz (*cycles per second*) unless measures are taken to reduce *Q*. Even in practice (which almost never agrees with theory), 50-Hertz bandwidths are common with 455-kHz crystal filters.

So far as external circuitry is concerned, the crystal appears to be exactly the same as an L-C resonant circuit except for its phenomenal *Q* value. See Fig. 6.

At series resonance, the crystal has very low impedance. You may hear this effect referred to as a zero of the crystal. At parallel resonance, impedance is very high; this is sometimes called a *pole*. Fig. 7 shows a plot of *pole* and *zero* for a typical crystal. The special kind of crystal filter known as a half-lattice circuit matches the *pole* of one crystal against the *zero* of another, to produce a passband capable of splitting one sideband from a radio signal. Such filters are widely used in ham, commercial and, to a lesser extent, in CB transmitters.

When a crystal is used to control the frequency of a radio signal or provide a source of accurate timing signals, either the *pole* or the *zero* may be used. Circuits making use of the *pole* allow more simple adjustment of exact frequency, while those making use of the *zero* often feature parts economy. Later we'll examine several of each type.

From Rock to Finished Crystal. To perform its control functions properly, a quartz crystal requires extensive processing. The raw quartz crystal must be sliced into plates of proper dimension, then ground to the precise size required. Each plate must be as close

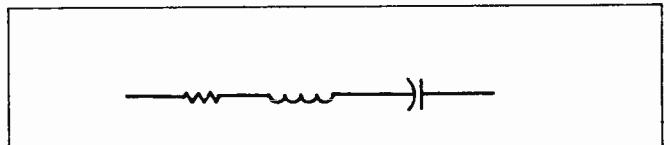

Fig. 6. Diagram is a typical equivalent circuit for a crystal. As resistance is lowered to near zero, crystal efficiency increases. In use, the crystal holder and external circuit add some capacitance across the entire circuit.

to precisely parallel, and as perfectly flat, as possible. The electrodes must be in proper contact with the polished plate; in many modern units, the electrodes are actually plated directly to the crystal surface, usually with gold.

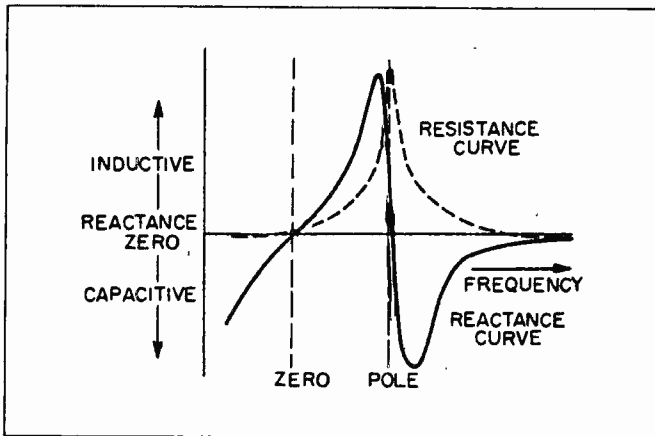

Fig. 7. Some characteristics of a quartz crystal. When slightly off resonant frequency (at the pole) a crystal exhibits inductive or capacitive reactance—just like an LC circuit.

The crystal plate is known as a *blank* when it is sliced from the raw crystal. The blank is cut at a precise angle with respect to the optical and electrical axes of the raw crystal, as shown in Fig. 8. Each has its own characteristics for use in specific applications. Some, notably the X- and Y- cuts, are of only historic interest. The Y- cut, one of the first types used, had a bad habit of jumping in frequency at critical temperatures. The X- cut did not jump, but still varied widely in frequency as temperature changed.

Today's crystals most frequently use the AT cut for frequencies between 500 kHz and about 6 MHz, and the BT cut for between 6 and 12 MHz. Above 12 MHz, most crystals are specially processed BT or AT cuts used in *overtone* modes. These cuts are important to crystal makers and not relevant to our layman's theory.

The blanks are cut only to approximated size. The plates are then polished to final size in optical "lapping" machines which preserve parallelism between critical surfaces. During the final stages of polishing, crystals are frequently tested against standard frequency sources to determine exact frequency of operation.

If electrodes are to be plated onto the crystal surfaces, frequency cannot be set precisely by grinding since the electrodes themselves load the crystal slightly and cause a slight decrease in operating frequencies. These crystals are ground just a trifle above their intended frequencies, and the thickness of the electrodes is varied by varying plating time to achieve precision.

Accuracy. The precision which can be attained in production of quartz crystals is astounding. Accuracy of ± 0.001 percent is routine, and 10-times better accuracy is not difficult. In absolute figures, this means an error of one cycle per megahertz. In another frame of reference, a clock with the same accuracy would require more than 11 days to gain or lose a single second.

However, such accuracy can be achieved only when certain precautions are taken. For instance, the frequency of a crystal depends upon the circuit in which it is used as well as upon its manufacture. For an accuracy of $\pm 0.005\%$ or greater, the crystal must be ground for a single specific oscillator. If $\pm 0.001\%$ (or better) circuit accuracy is required, it must be tested in that circuit only. Thus, CB transmitters are on the narrow edge of being critical. This is why all operating manuals include a caution to use only crystals made specifically for that transmitter.

When one-part-per million accuracy is required, not only must the crystal be ground for a single specific oscillator, but most often the oscillator circuit must then be adjusted for best operation with the crystal; this round-robin adjustment must be kept up until required accuracy is achieved. Even then, crystal aging may make readjustment necessary for the first 12 to 18 months.

Frequency Variation—Causes and Cures. Possible variations in frequency stem from three major causes, while cures depend entirely upon the application.

The most obvious cause of frequency variation is temperature. Like anything else, the crystal will change in size when heated and the frequency is determined by size. Certain cuts show less change with temperature than do others, but all have at least some change.

For most noncommercial applications, the heat-resistant cuts do well enough. For stringent broadcast station and critical time-signal requirements, the crystal may be enclosed in a small thermostatically-regulated oven. This assures that the steady temperature will cure one cause of frequency change.

The second well-known cause for variation of frequency is external capacitance. Some capacitance is always present because the crystal electrodes form the plates of a capacitor where the crystal itself is the

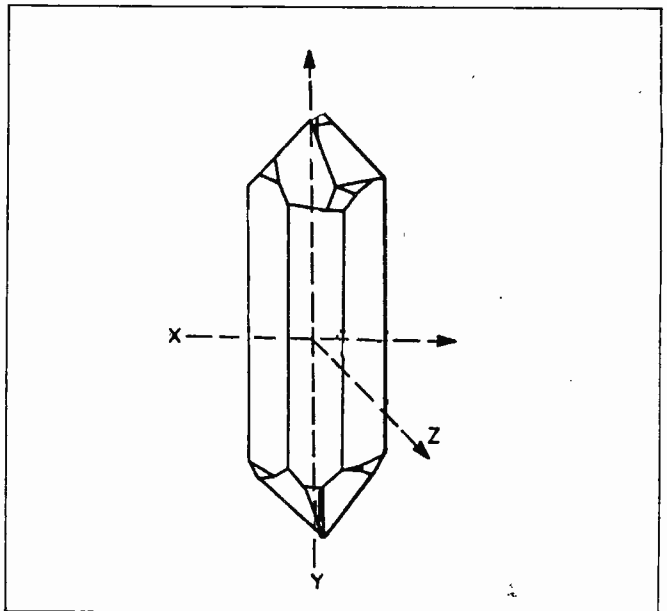

Fig. 8. A view of a mother crystal showing X, Y, and Z axes. Crystal is sliced into blanks, ground to frequency, polished and plated (on facing sides) to make permanent electrodes. All crystals are not made perfect by Mother Nature and must be examined optically before being sliced.

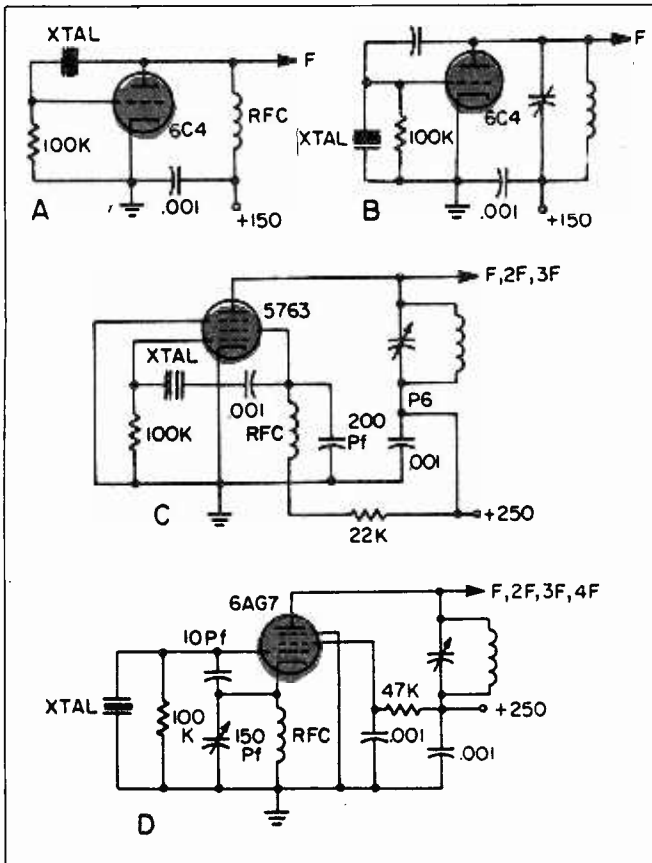

Fig. 9. The simplest crystal oscillator circuit (A) has no tuned circuits. To change frequency it is only necessary to change crystals, although a small variable capacitor across the crystal will cause some small frequency change. Miller oscillator (B) is nearly as simple as Pierce type shown in (A). Tuned circuit can pick out fundamental frequency or harmonics. Pierce electron-coupled oscillator (C) derives its feedback from the screen circuit, eliminating need for a buffer amplifier in most cases. Colpitts oscillator (D) gets its feedback from cathode circuit. Variable capacitor in the grid-cathode circuit can trim frequency.

dielectric. Most crystals intended for amateur use are designed to accommodate an external capacitance of 32 picoFarads (pf) so if external capacitance is greater than this, the marked frequency may not be correct. Crystals for commercial applications are ground to capacitance specifications for the specific equipment in which they are to be used. CB crystals also are ground for specific equipment, although many transceivers employ the 32 pF standard.

Trim a Frequency. When utmost precision is required a small variable capacitor may be connected in parallel with the crystal and adjusted to change frequency slightly. The greater the capacitance, the lower the frequency. Changes of up to 10 kHz may be accomplished by this means, although oscillation may cease when excessive changes are attempted.

The third cause for variation of frequency is a change in operating conditions in the associated circuit. This cause is more important with vacuum tube circuits than with semiconductor equipment. As a rule, operating voltages for any vacuum-tube oscillator providing critical signals should be regulated to prevent change.

Again, this cause can be used to provide FM by

deliberately varying voltages.

Crystal Aging. A final cause of frequency variation, small enough to be negligible in all except the most hypersensitive applications, is crystal aging. When a crystal is first processed, microscopic bits of debris remain embedded in its structure. These bits are displaced during the first 12 months or so of use, but during that time the crystal frequency changes by a few parts per million. Extreme accuracy applications must take this change into account. For most uses, though, it may be ignored.

Using Quartz Crystals. After all the discussion of crystal theory, it's time to examine some typical circuits. While dozens of special crystal circuits have been developed for special applications, a sampling will suffice for discussion. Fig. 9 shows four typical vacuum tube crystal oscillator circuits.

The simplest of these is the Pierce circuit. Fig. 9A. While at first glance this circuit appears to employ the crystal's zero to feed back energy from plate to grid, the pole is actually used through a mathematically-complex analysis. This circuit has one unique advantage: it contains no tuned elements and, therefore, can be used at any frequency for which a crystal is available. This makes it an excellent low-cost test signal source. The major disadvantage is that excessive current may be driven through the crystal if DC plate voltage rises above 90 or so.

The Miller oscillator (Fig. 9B) is almost as simple to construct and operate as is the Pierce and has an additional advantage of operation with overtone crystals. This is the circuit recommended by *International Crystal Mfg. Co.* for use with their overtone crystals. The capacitor shown between plate and grid is usually composed of grid-plate capacitance

(Continued on page 96)

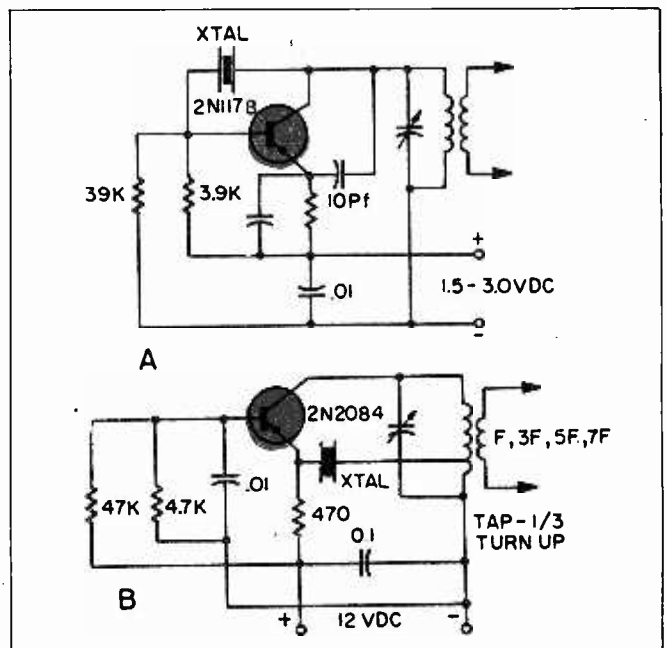

Fig. 10. Fundamental frequency transistorized oscillator (A) is quite similar to that in Fig. 9A. One difference is that tuned circuit in output replaces RFC unit. The overtone (harmonic) circuit (B) uses crystal for odd harmonic feedback. Either circuit can be used for fundamental frequency operation—just tune.

ONE EVENING WORKSHOP PROJECTS

It seems like every electronics project undertaken is the beginning of a great shopping expedition with phone calls to several "800" numbers and tours to parts centers located in city hubs. Once the parts are collected (and if the desire to proceed is still strong) the builder finds that a rats nest of parts and wires must be squeezed into a small box—there must have been a smaller, cheaper circuit! Sure there is, and you'll find them on the following pages.

The first few projects are what we call light (lamp) projects.

We've come up with some unusual ways to turn on lights. These lights can be substituted for appliances or other exotic devices that you can think of. Our intent is not to short out the North American power grid or light up the night sky. Light projects seem to excite many of our readers, so we keep them excited.

Parts for these projects are most probably available in your spare-parts box. When you purchased a 2N2222 OR 2N2222A transistor for the last project, the chances are that you purchased a peg-board package with three or four transistors in them. With that in mind, we try to present projects that use parts that are not critical in ratings. Thus, common, replacement-type parts may be used.

Keep your multimeter on the bench as you work. It may be the only instrument you will need to build the projects presented here. Inspect and test every component as best you can before you can put into a circuit. One defective part in a circuit is sometimes very hard to locate, and it may cause the destruction of others.

Now, go on—make your day!

PROJECT WORKBENCH

FLOODLAMP LIFE SAVER

While looking through diode specification sheets I came upon an ultrasimple circuit that was almost too good to be true. For years hobbyists have been inserting a diode in series with a photoflood lamp to reduce power by almost half, and then shorting out the diode so that the lamp receives the full power from the AC line. Later, triacs came on the scene and the switching became a bit fancier. Now take a look at the circuit in Fig. 1.

As is the case, most light bars have two or an even number of photofloods, because the pair will reduce

hard shadows. With switch S1 open, both lamps are in series with a diode that rectifies the AC line so that power is delivered to the lamps only one-half of the time. With switch S2 closed, diodes D1 and D2 are connected to each other in a back-to-back circuit so that both halves of the AC power is passed through as if the diodes were a hank of wire. Lamps L1 and L2 come to full brightness. Actually, a fraction of a volt is lost in the diodes, but compared to the 117-volt AC LINE, the loss is less than 0.5%.

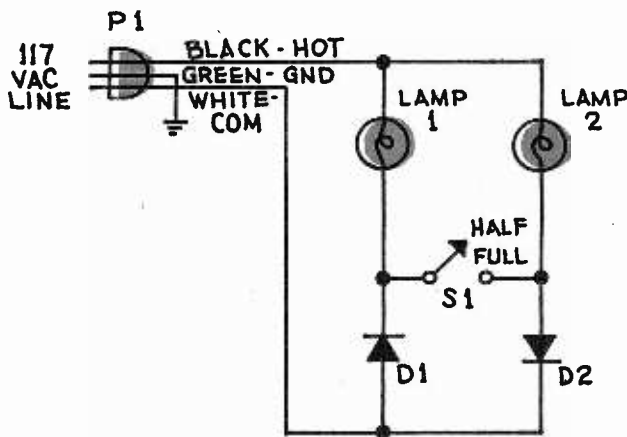

PARTS LIST FOR FLOODLAMP LIFE SAVER

- D1, D2—Diode rectifier rated at 400 PIV and 5 amperes
- L1, L2—150-watt photoflood lamps
- P1—Power cord with molded power plug, 3-wires
- S1—SPST toggle switch

REMOTE-CONTROL POWER CIRCUIT

Every so often there's a need for a remote-control circuit to energize a light or appliance at a time when you physically must be someplace else in the house. You could call an electrician to run a special line, but you'll only discover that the cost is usually \$150 plus cost of materials and parts. Also, you'll have to plaster the holes left behind and do some repainting. What you need is a simple circuit that will do the job. The line that is run through the house is bell wire (something you can install yourself), legally and safely.

The circuit in Fig. 2 can control lamps up to 500 watts and motors requiring about 300 VA. The triac, TR1, is at cutoff with the potentiometer, R1, so set that a slight lowering of the resistance would trigger the triac into conduction. Since the transformer's secondary winding is open, T1 passes a minute current through its primary winding. When the remote switch, S1, is depressed, current flows in the secondary winding causing an increase in current in the primary winding of T1. This added current upsets the delicate cutoff

setting off the triac, and TR1 is fired. In effect, TR1 is a short circuit across the series circuit T1 and R1 so that two events occur at the same time: The first is that no further power is supplied to T1, and second, all the power entering the circuit through P1 is delivered to outlet SO1. The latter is obvious when your mind's eye draws a line through TR1 to symbolize a dead short—then the power path to SO1 becomes more apparent.

The two fuses play an important role. Fuse F1 limits the power available to SO1 thereby protecting the circuit from damage from a serious overload. Fuse S2 is a safety factor in the event the triac fails to conduct and power to T1 is not removed. The bell wire could "burn" when passing excessive current. The use of a normally-open pushbutton switch will open the circuit after the finger is removed—but not so should a child play with the button. One alternative for added safety is to use the fuse F2 and a 10-volt AC doorbell transformer. That inductive device has a high internal resistance so that a short across its secondary winding

PROJECT WORKBENCH

will only raise the heat in the transformer to a warm, but safe, level. Using a bell transformer. The bell wire will not conduct dangerous levels of current and it will not heat up! That transformer can be purchased at your local electrical supply outlet.

Triac TR1 will heat up when conducting and a heat sink with a minimum of 10 square inches will be required to keep its operating temperature down. You could fabricate the heat sink using sheet aluminum or

copper with a minimum size of 3-¼ by 3-¼ inches. A metal chassis box should house the unit and install the heat sink so that it is electrically isolated from the metal box.

To turn off the circuit the power must be removed for P1. Opening switch S1 will have no effect whatsoever. If this remote-control circuit is the kind of circuit you want, you can save big bucks!

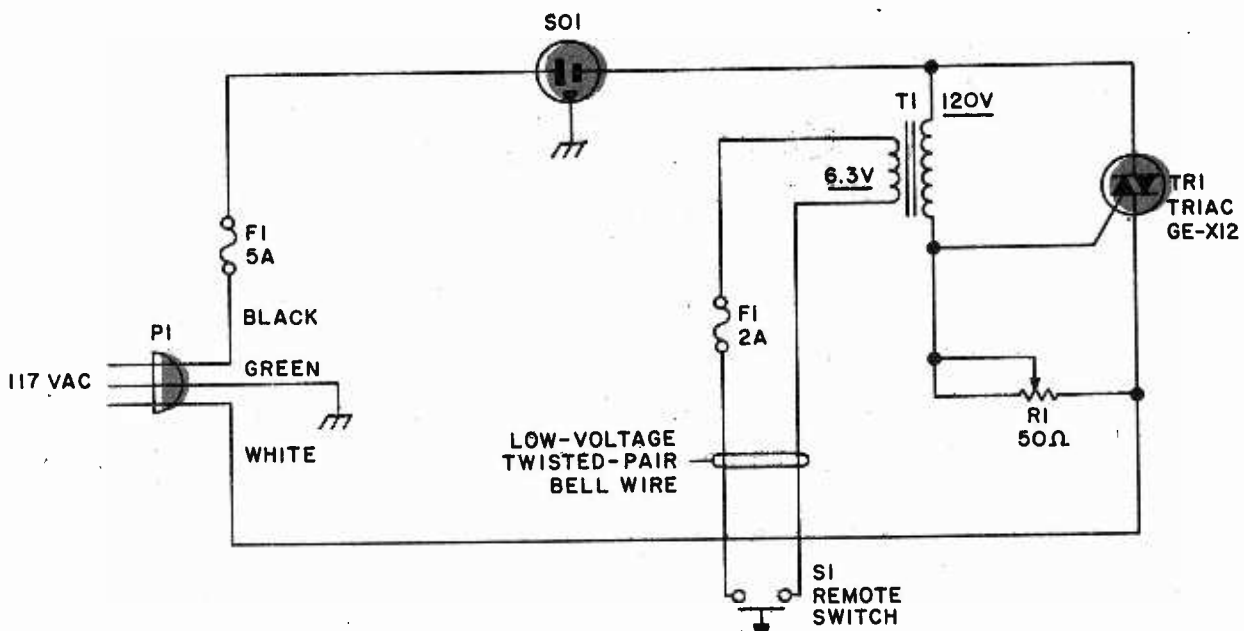

PARTS LIST FOR REMOTE-CONTROL POWER CIRCUIT

- F1**—5-ampere, cartridge fuse and fuse holder, 34G size is suitable
- F2**—2-ampere, cartridge fuse and fuse holder, 34G size is suitable
- P1**—3-wire power cord with molded plug
- R1**—50- to 100-ohm, 2-watt potentiometer
- S1**—SPST, pushbutton or toggle switch
- SO1**—3-wire, AC-power outlet
- T1**—Filament transformer: 120-VAC primary: 6.3-or

- 12-volt secondary rated at .5 to 2 amperes (lower values preferred)—10-volt bell transformer may be used (see text)
- TR1**—GE-x12 triac, or equivalent (any 6- to 10-ampere triac is suitable)
- 1**—Heat sink with 10 square-inches off cooling area
- 1**—Chassis box of sufficient size, sheet metal or aluminum

PROJECT WORKBENCH

EMERGENCY LIGHT

What happens when the lights go out in your home. You sit in darkness until someone finds the flashlight with dead batteries—isn't that the way it always happens? That does not have to be the case in your home. When the power fails, a small, but serviceable light comes on so that you can find your way about without the attending shin bangs and scratches.

The circuit in Fig. 3 is very simple and does all the work. With the AC power on capacitor C1 charges through diode rectifier D1 developing a negative voltage at the gate of the silicon control rectifier SCR1. In this state, SCR1 cannot be triggered and the emergency light, I1, stays off.

The battery is kept fully charged by diode rectifier D2 and current-limiting resistor R3. The size of R3 should be sufficient to limit the current to the trickle-charge rate of the battery you use. You could use D-size rechargeable cells or even a pair of 6-volt motorcycle batteries wired in series. The test circuit limited the current to under 1 mA, and the battery was always charged.

When the house lights go out, capacitor C1 discharges and SCR1 is triggered by the battery via resistor R2. The emergency light comes on and the recharging process begins.

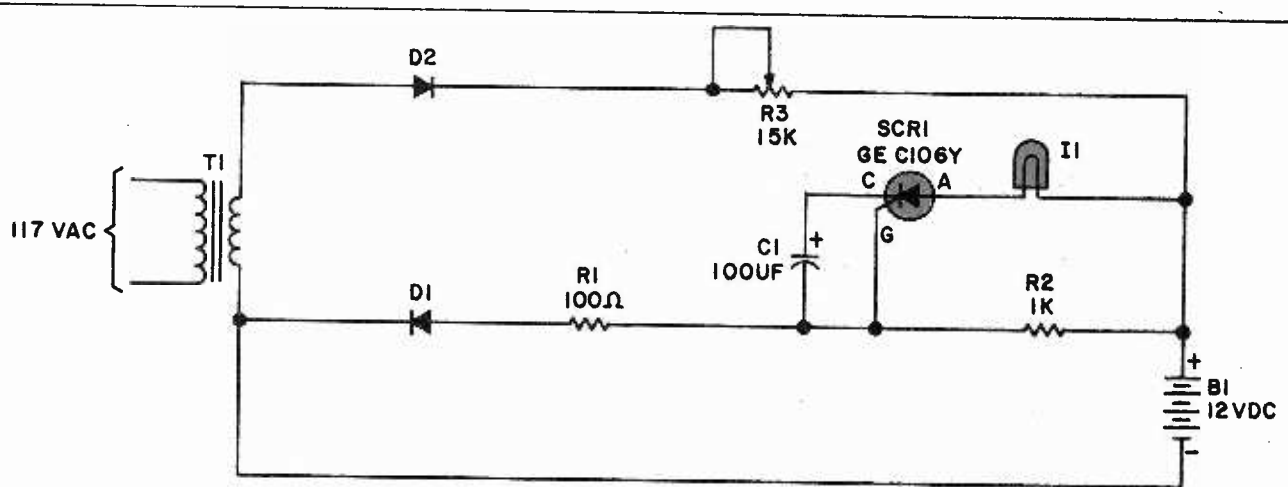

PARTS LIST FOR EMERGENCY LIGHT

B1—12-volt, rechargeable battery, AH capacity rating of 6 suggested

C1—100- μ F, 20-25-WVDC, electrolytic capacitor

D1, D2—IN4001 diode rectifier

I1—12-volt lamp, auto type

R1—100-ohm, $\frac{1}{2}$ -watt, 10% resistor

R2—1000-ohm, $\frac{1}{2}$ -watt, 10% resistor

R3—15,000-ohm, 2-watt potentiometer

SCR1—Silicon-controlled rectifier, GE C106Y or equivalent

T1—Filament transformer: 117-VAC primary; 12.6-VAC secondary at 1 ampere

OVERFLOW INDICATOR

You'd like to know when the sump pump in the basement failed, and you like to know immediately. With that in mind, we present to you the Overflow Indicator.

The two probes (see Fig. 4) can be set in the sump hole at the floor level, or where the overflow occurs. The water should never get this high under normal conditions, so a warning is desirable. This circuit triggers and stays on even after the water level

recedes from the probes opening the detector circuit.

The relay selected is a Radio Shack type with a 75-mA pull-down current. With this little current, any silicon-controlled rectifier will work. However, should you use a larger and higher-rated relay, be sure that the current draw of the relay coil is below the current rating of the SCR by a factor of $\frac{1}{2}$. The circuit can be powered by a 12-volt battery, or whatever the rating of the relay coil may be.

PROJECT WORKBENCH

The alarm you select is up to you. The minimum should be a flashing bulb rated at 15 watts or more located where you can't miss it when in or entering the

house. Maybe two or more bulbs are needed. As for a gong—that's up to you!

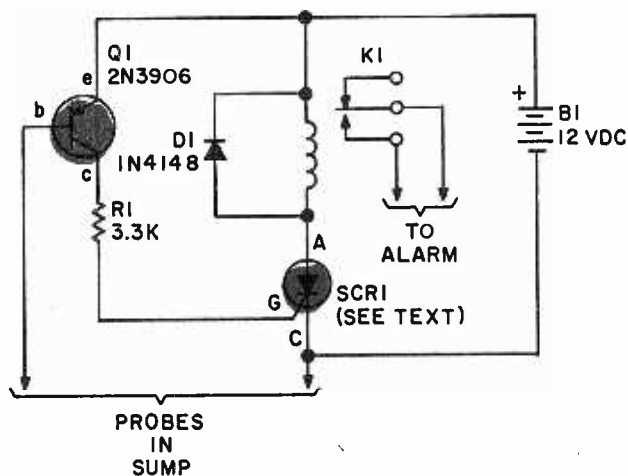

PARTS LIST FOR OVERFLOW INDICATOR

- B1**—12-volt battery (to match coil of relay K1)
- D1**—1N4148 diode
- K1**—SPDT, 12-volt DC, miniature relay with contacts rated at 125-VAC at 3 amperes (Radio Shack type 275-206, or equivalent)
- Q1**—2N3906 switching PNP transistor
- R1**—33,000-ohm, ¼-watt, 10% resistor
- SCR1**—Silicon-controlled rectifier, any low-current type to match relay used (see text)

BUDGET LAMP DIMMER

No group of projects on lamp control can be complete without a budget lamp dimmer as shown in Fig. 5. The circuit does not go from full dark to full brightness immediately, it first must trigger TR1 at a medium-brightness level and then the potentiometer (R2) positioned to attain a suitable level of illumination from L1, either above or below the initial brightness level.

What is nice about this circuit is the cost—it's mighty low and most of the parts are usually found in the junkbox. The neon gate serves the same function as a triggering diode (bi-directional avalanche switch), such as the D3202U and 276-1649 (Radio Shack).

Assemble the device in a plastic or aluminum chassis box. Triac TR1 can handle up to 400 watts of a resistive load without a heat sink.

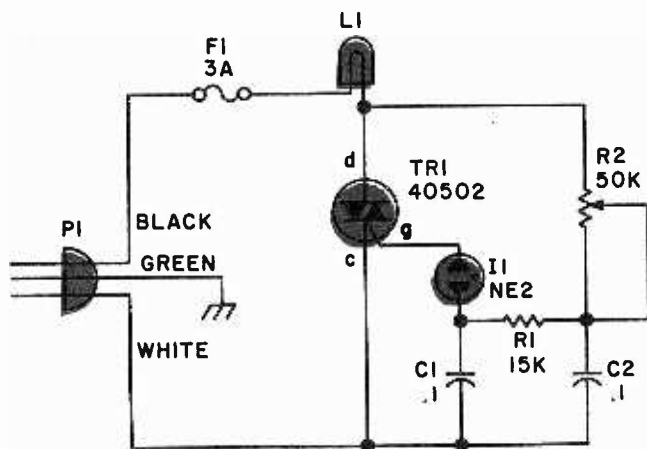

PARTS LIST FOR BUDGET LAMP DIMMER

- C1, C2**—.1-uF, ceramic capacitor
- F1**—Fuse, 3 amperes, 3AG type with holder
- I1**—NE-2 neon bulb with wire leads
- L1**—Household light bulb up to 400 watts may be paralleled together
- P1**—power cord with molded power plug, 3-wire
- R1**—12,000-ohm, ½-watt, 5% resistor
- R2**—50,000-ohm, linear-taper potentiometer
- TR1**—Triac 40502 (RCA), or equivalent

PROJECT WORKBENCH

ANOTHER FUZZ BOX

Here's Another Fuzz Box, a simple low-level output circuit that can be added to an existing amplifier or outboarded in an aluminum chassis box with a battery power supply. The drain is low so that a transistor-radio battery will last several sessions with the band.

The quality of the two amplifying stages leave much to be desired, however, in a fuzz circuit they fill the bill. Diodes D1 and D2 clip the output. Capacitor C6 rolls off the high frequencies. When intensity potentiometer R1 is at the bottom of its travel (see Fig. 6), all of the input signal is fed directly to the output terminal. As the potentiometer's wiper is advanced upward, an

increasing amount of signal is fed to the fuzz circuit and less is fed to the output terminal directly. The degree of mix, if any is left to the musician's desires!

As in all audio projects, ground loops will degrade the program, so some careful work is in order. Connect a No. 14 or No. 12 solid copper wire between the ground terminals of the input and output connectors. The ground connections in the circuit should progress on the copper bus as seen in the diagram from left to right. The battery's negative terminal should be connected close to the output terminal's ground.

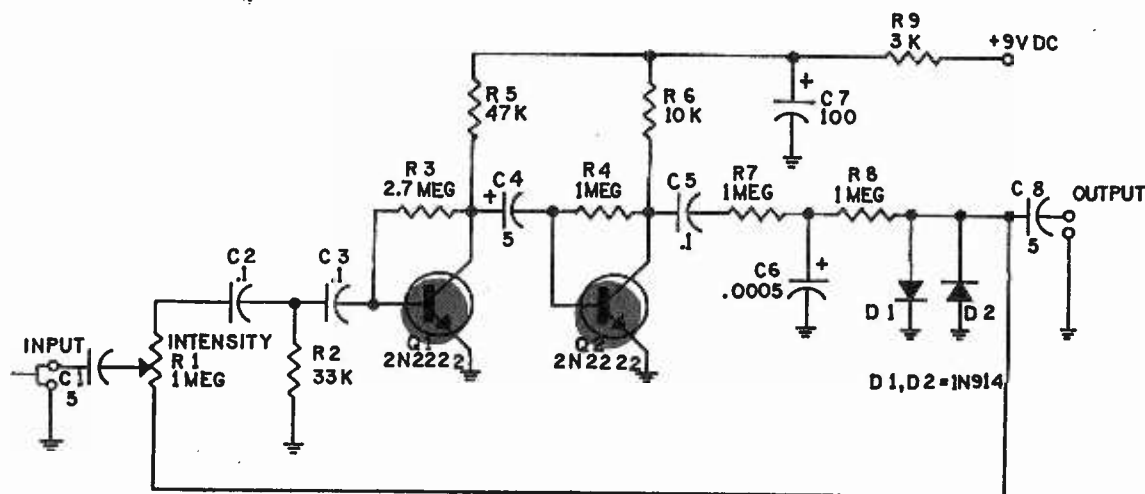

PARTS LIST FOR ANOTHER FUZZ BOX

- | | |
|--|--|
| C1, C4, C8 —5-uF, 16-WVDC, electrolytic capacitor | R2 —33-ohm, ½-watt, 5% resistor |
| C2, C3, C5 —.1-uF, ceramic capacitor | R3 —2.7-Megohm, ½-watt, 5% resistor |
| C6 —.0005-uF, ceramic capacitor | R5 —47,000-ohm, ½-watt, 5% resistor |
| C7 —100-uF, 16-WVDC, electrolytic capacitor | R6 —10,000-ohm, ½-watt, 5% resistor |
| D1, D2 —1N914 diode | R7, R8 —1-Megohm, ½-watt, 5% resistor |
| Q1, Q2 —2N2222 transistor | R9 —3000-ohm, ½-watt, 5% resistor |
| R1, R4 —1-Megohm, linear-taper potentiometer | |

PORTABLE POWER FREQUENCY CHECKER

The hurricane passed you by with only some blown trash on the lawn and loss of power. No problem at all. All you have to do is power up the gasoline-driven power supply and tie in the house's freezer and refrigerator to the supply. Your frozen food supply will be safe and the trash in the yard can wait till tomorrow. Life can be beautiful.

Sure it can! But not for you! The power supply starts up quickly and seems to be working fine. A 100-watt light bulb tied to it burns brightly indicating that the voltage is good—the unit's meter attests to that! But—why did the refrigerator's motor overheat during the night and burn out; and why is the freezer motor laboring so hard? Oh! Oh!—more smoke coming from

PROJECT WORKBENCH

the freezer!

If you had a frequency meter to connect to the power-supply line you would have noted that the line frequency was about 47 Hertz—much too low. Sixty-cycle motors can't operate for long at reduced line frequencies. If you only had a frequency meter.

Well, for a few pennies you can make your own! Refer to Fig. 7. The Power-Line Frequency Meter samples the 117-volt AC LINE by dropping the voltage across R1 and developing 6.8-volt square waves with Zener diode D1. The square wave is differentiated by capacitor C1. The meter circuit and the diodes (D2 and D3) average the current and an indication is obtained. In the low power frequency range, the average current through the meter is proportional to the frequency of the AC

line. Calibration is simple: connect the circuit to the utility's power line (pre-hurricane) and adjust R2 for 60 milliamperes. Now, over the top two-thirds of the meter dial (on a 100-milliamperere scale) will indicate power-line frequency very accurately within the 3% rating of the meter. You could use your multimeters 100-mA scale setting should a 0-100 mA DC meter be unattainable.

Make your Power-Line Frequency Meter today. Put into a metal or plastic box and include a 3-wire power cord with plug so that connection to the power-line's outlet can be done quickly. The power cord can be as short as one foot. Now your family and home will be ready for the next tropical storm coming your way!

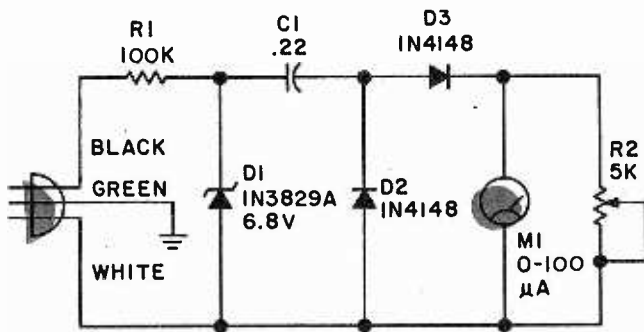

PARTS LIST FOR POWER-LINE FREQUENCY METER

- C1— .22μF, ceramic disc capacitor
- D1—IN3829A Zener diode, 6.8-volt, 1-watt
- D2, D3—IN4148 diode
- M1—0-100-mA DC meter (see text)
- P1—power cord with molded plug, 3-wire
- R1—100,000-ohm, 2-watt resistor (use four 390,000-ohm, ½-watt resistors in parallel)
- R2—5000-ohm, linear-taper potentiometer

HARMONIC GENERATOR

If you are into shortwave listening, amateur radio, and other high-frequency activities, here is a harmonic generator that will produce harmonics up to 150 MHz from a 1000-Hertz input signal. See Fig. 8. Don't try to improve on the circuit by switching the germanium diode (D1) with a silicon type—that's a big mistake! The input signal required to drive the circuit can be

between .15 to 1.0 volts input. If your interest lie in the broadcast band or there about, increase the size of C3 for more output.

Since the power required for the circuit can be delivered by a dry cell, use one and keep it simple. If you must get into circuit improving, try a tunnel diode in place of the germanium diode—if you can find one.

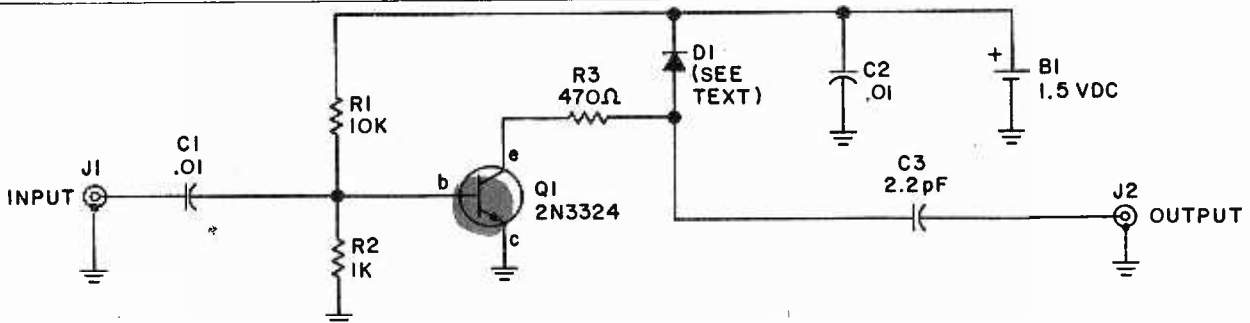

PARTS LIST FOR HARMONIC GENERATOR

- B1—1.5-volt DC dry cell, AA- to C-type
- C1, C2— .01-μF, ceramic capacitor
- C3—2.2-pF, ceramic capacitor
- D1—IN34 germanium diode (see text)
- J1—Phono jack, RCA type
- J2—BNC connector (male or female)
- Q1—2N3324 transistor, or equivalent
- R1—10,000-ohm, ¼-watt, 5% resistor
- R2—1000-ohm, ¼-watt, 5% resistor
- R3—470-ohm, ¼-watt, 5% resistor

PROJECT WORKBENCH

ONE-TRANSISTOR AUDIO MIXER

Sometimes we resort to whole console of circuitry to do the job that can be done by one transistor. In the example shown in Fig. 9, one transistor, Q1, and its associated circuitry is all that is required to mix three

audio channels into one output line. It's a simple summing circuit with the base-emitter resistance being the summing resistor. The circuit offers a gain of about 20.

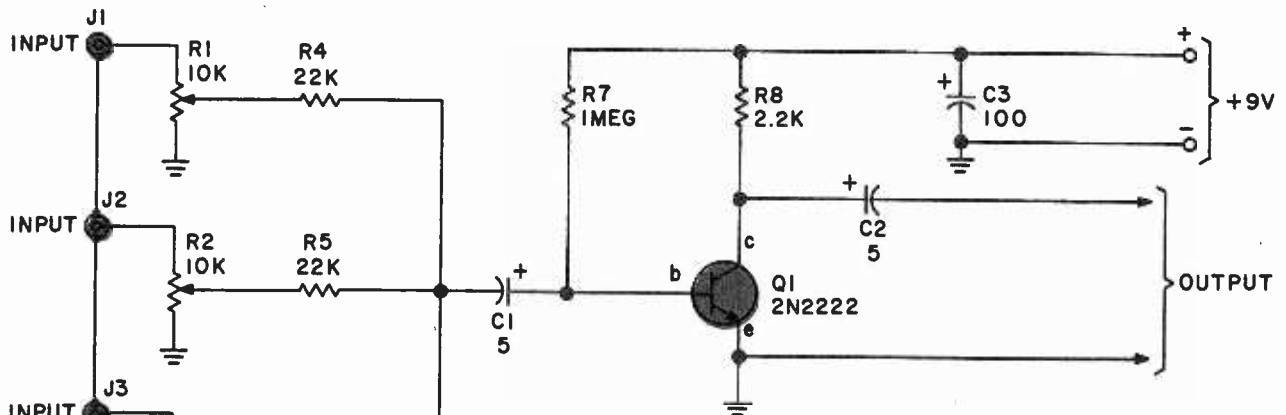

PARTS LIST FOR ONE-TRANSISTOR AUDIO MIXER

- C1, C2—5-uF, 16-WVDC, electrolytic capacitor
- C3—100-uF, 16-WVDC, electrolytic capacitor
- J1-J3—Phono jack, RCA type
- Q1—2N2222 transistor
- R1-R3—100,000-ohm, audio-taper potentiometer
- R4-R6—22,00-ohm, ¼-watt, 5% resistor
- R7—1-Megohm, ¼-watt, 5% resistor
- R8—2200-ohm, ½-watt, 5% resistor

AUDIO OSCILLATOR

The simple two-transistor circuit shown in Fig. 10 produces enough volume to drive a small 4- to 8-ohm loudspeaker. The values of R1 and C1 may be varied over a large range and still get an audio output. The transistors used are not critical to the circuit operation so that you can make substitutions with similar audio-type transistors. A 9-volt transistor-radio battery can power the circuit.

Inset a key into the battery circuit and the device can be used to practice Morse code. Make the battery leg a perimeter loop and the device can be used to announce visitors and detect intruders.

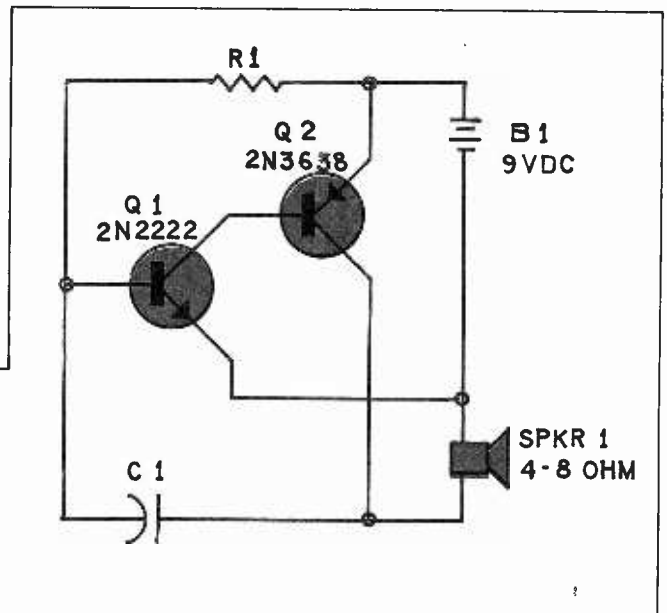

PARTS LIST FOR AUDIO OSCILLATOR

- B1—9-volt transistor-radio battery
- C1—.02-.06-uF, disk capacitor
- Q1—2N2222 transistor
- Q2—2N3638 transistor
- R1—5000-150,000-ohm, ½-watt, 10% resistor
- SPKR1—Loudspeaker with 4- to 8-ohms voice coil

HOW TO KEEP YOUR CASSETTE MACHINE PLAYING

By Homer L. Davidson

The defective cassette player with the possibility of many different mechanical and electronic problems can be repaired by the beginner, novice, experimenter and intermediate electronic technician (FIG. 1). Most mechanical defects are: The buttons will not engage; no tape motion; and slow and erratic speeds. The no sound or record mode may be caused by a defective tape head or amplifier section. Improper recording may result from a dirty record head or no bias voltage. The possibilities are almost limitless.



Fig 1. Here is a stereo cassette tape deck found with separate rewind, play, fast forward, record, stop and pause push buttons controlled with a solenoid circuit.

Servicing the cassette player requires only a few tools found around the house. Just a pair of long nose pliers with side-cutters and a couple of small Phillip and blade screw drivers are all that is needed. A VOM or DMM helps to check voltages and resistance measurements. The digital-multimeter (DMM) is ideal to check out transistors with the diode-transistor test and to measure real low voltage at the IC-amplifier terminals. Now lets attack some of the problems.

Can Not Open Cassette Door

Suspect a jammed mechanism or tape wrapped around the capstan drive (with no tape motion and the

cassette door will not open). At first, one suspects the door latch is frozen so the door will not open. Often this is not the case. Since the cassette slides into the door assembly and is then closed for play/record mode, excessive tape may pull out and wrap around the capstan preventing the door from opening.

With some cassette players the front plastic cover may be removed by sliding it upwards or removing two small screws. Now try to remove the excess tape from the capstan area. Usually, the tape winds real tight

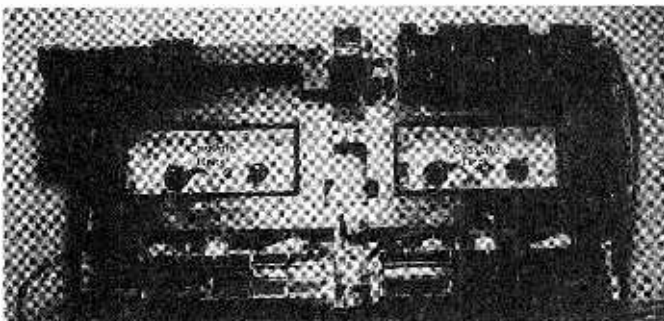

Fig 2. Sometimes the tape deck must be removed from the cabinet to remove excess tape and cassette. Here two separate model.

around the capstan and builds up to a large form preventing the door to open. Try to pull out the excess tape without damaging the door or pressure roller.

Remove the player from the cabinet if the excess tape cannot be removed from the front area (Fig. 2). Sometimes, just removing the back cover may help locate the capstan flywheel. Rotate the flywheel backwards to help unravel the tape. This direction would be clockwise looking at the back of the cassette player. Keep pulling on the door until you can get the door open. In some cases you may have to cut loose sections of tape until the cassette is free. Sometimes a stiff piece of wire pushed down between cassette and

BUDGET PROJECTS

door opening may snag pieces of tape so the door will release. Be real careful not to break the plastic door or hinges.

After the excess tape is removed and the door will operate, clean up the tape head and capstan. You may find excess tape oxide upon the capstan area. Clean off with alcohol and cotton cleaning sticks. Wipe all oxide residue off of pressure roller and tape head. Be careful not so scratch the tape-head front surface. A cloth soaked in alcohol and held firmly upon the pressure roller with roller rotating helps remove the brown tape dust.

Buttons Will Not Stay Down

When the play or fast forward buttons will not hold down, suspect a bent lever or sliding bar (Fig. 3). Sometimes extensive pressure against the sliding bar will bend the bar down in the middle and will not let the small shaft hook into the bar area. Simply remove the

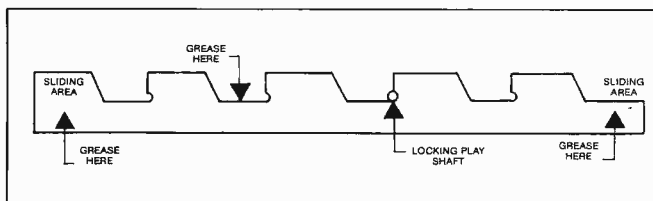

Fig 3. Check for a bent return lever when the pushbuttons will not stay down in the cassette player. Bend the lever at the middle area so the small shaft will lock into the lever and hold the button down.

tapedeck and check the sliding bar. Bend the bar upwards into position. Make sure the bar slides easily back and forth. Clean up the old grease from the bar sliding areas and apply light grease such as *Vaseline* or *Phono-lube*. Check the spring tension at the end of the sliding bar. The spring may come loose, or, if a leaf-type spring, check for a loose mounting screw.

In cassette decks with automatic loading and ejection systems the relay may not hold with a dirty automatic play switch. Locate the play switch and clean contacts with a spray type cleaner. Push the plastic end down into the switch area and move the lever back and forth to clean up the contacts. In some automatic models, when the play button will not hold in with slow speed, check for the off-pulley belt down around the motor shaft. Sometimes these automatic cassette decks will kick the play button out when the motor belt is off, or the capstan flywheel will not rotate.

The play or record buttons that separate or come loose from the small thin levers may be repaired with epoxy. Regular glue does not hold the plastic button to the metal lever area for any length of time. Mix up the epoxy and apply on both lever and plastic button. Insert button in place and turn cassette front side down so the epoxy can set up.

Check the cassette itself when the record button will not push down. If the small area at the back of the

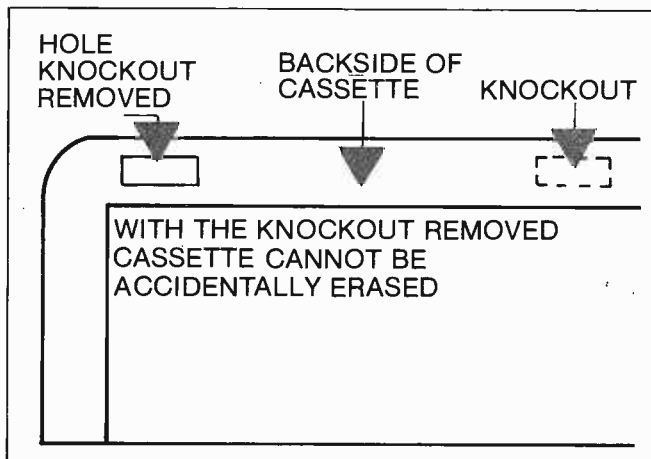

Fig 4. The record button may not engage when the knockout is out at the rear of the cassette. Check the cassette before attempting to repair the record-button assembly.

cassette is knocked out the cassette recording is protected from accidental erasing. Notice this knockout is found on all commercial recordings (Fig. 4). Remember when you can not engage the record button, check the cassette. The small knockout piece of plastic must be intact before you can record upon the cassette.

Dead No Tape Motion

Check the motor rotation with no cassette in place. Suspect a defective motor, motor belt off or broken and excessive tape wrapped around capstan with no tape rotation. First check for excess tape around capstan. Inspect the motor belt for correct tension and tracking. Replace the motor belt if too loose or broken. Take the old belt and model number of cassette player to the

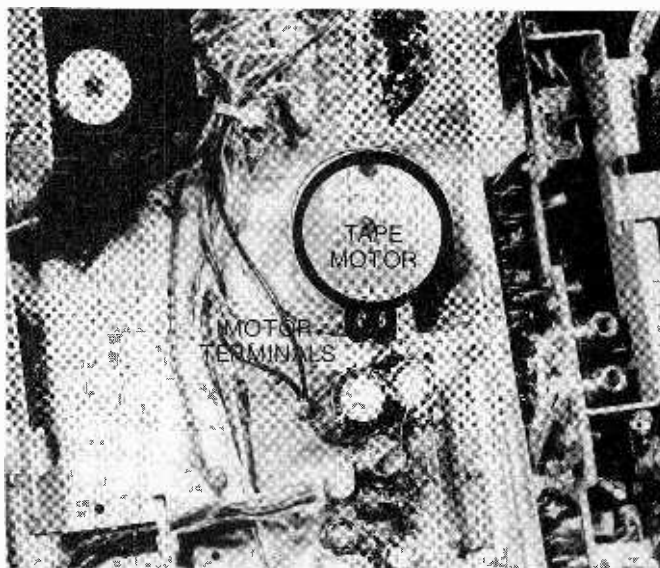

Fig 5. Replace the defective motor if correct DC voltage is found at the motor terminals with no tape to drive. The motor terminals are easy to get at in the Sanyo C3D model.

BUDGET PROJECTS

dealer where you purchased the unit or to a Radio-TV repair establishment.

Measure the voltage at the motor terminal (Fig. 5). The voltage may vary from 12 to 18 volts DC. If voltage is present at the motor terminals and the motor does not rotate, suspect a defective motor. Rotate the motor pulley by hand to see if it starts to run. If the motor spits and sputters, order out a new one if the cassette player is worth the price of the motor replacement. Again, take the motor and model number to your cassette dealer.

The intermittent motor may cause intermittent rotation and sound. Stop the motor pulley with your fingers and see if it will start up again. Sometimes the intermittent motor will not rotate after it is stopped. Monitor the DC voltage at the motor terminals and notice if the voltage swings up and down. Suspect a dirty off-on or play switch with intermittent or no voltage at the motor terminals. You may find a dirty or bent leaf on/off switch in the small cassette recorder resulting in no tape movement. Spray the switch with tuner cleaner.

No play/record rotation may be caused with the pause control in on position. Make sure the pause control is off or inspect the pause-control switch for a bad contact or wire off with no voltage at the motor. Intermittent rotation may be caused by a dirty pause-control switch. Check for a dirty play switch for intermittent, or no rotation and sound. Look for a broken wire at the switch terminals.

With the spindle rotating and no sound, suspect the cassette tape is not engaging the tape head. Look for a broken pin or something holding the tape carriage away from the tape head. Check for a broken loading spring, or it may be missing. Notice if the eject lever is

bent to keep the assembly from fully engaging at the tape head. The tape head may have one mounting bolt missing tilting the head away from the tape area. Often, two small head mounting bolts hold the head into position. The one on the right side is adjustable for azimuth adjustment. Adjust this screw so the head is level with the tape.

In automatic play and eject system, the tape may start and click out the play button. Often, the trouble symptom is caused by a rotating magnet upon the rear of the take-up spindle. If the magnet does not rotate the player will stop. Notice if the magnet is rotating (Fig. 6.). Check the motor-drive belt and capstan action. Remove the drive belt to the tape counter if loading down or binding magnet assembly. Suspect a defective IC or switch assembly under the rotating magnet assembly if the magnet is rotating.

Slow And Erratic Speeds

Usually, slow speeds are the results of oil upon the drive belt, loose motor belt and dry roller, or defective capstan bearings. Remove the motor belt and check for cracked areas or looseness. Clean off the motor belt, capstan drive area and idler pulley. (Fig. 7). Remove capstan/flywheel and remove old bearing grease. Place a dab of grease at the top bearing just below the drive area before replacing. Then place a dab of light grease upon the bottom bearing.

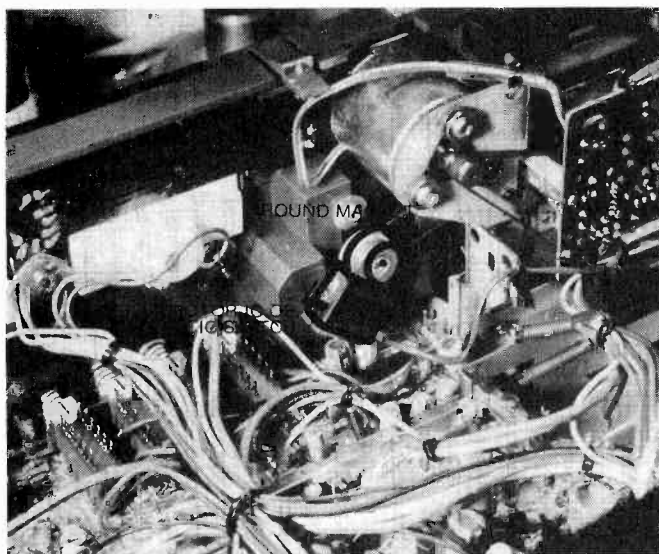

Fig. 6. In automatic models the start or play button may kick out if the round magnet is not rotating. Check for a loose or broken belt in this Sharp RT1115 model.

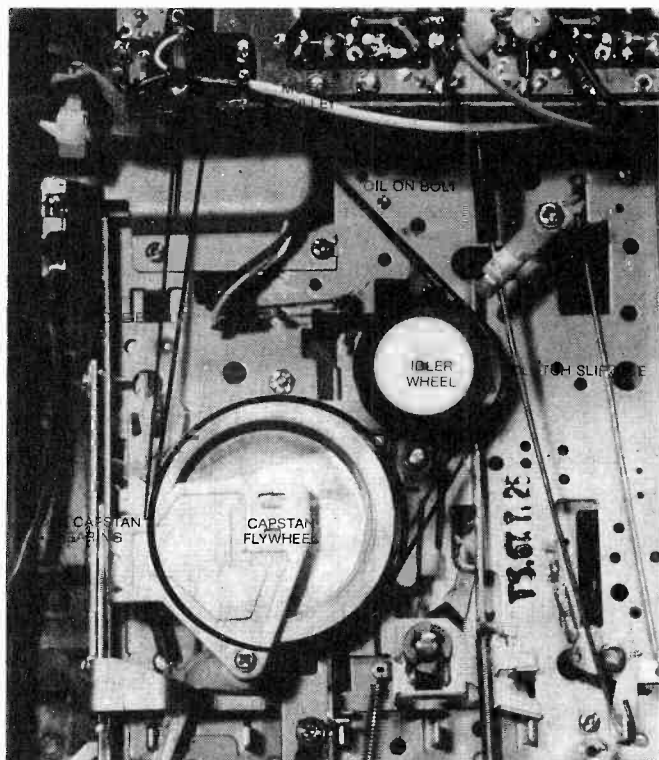

Fig 7. Slow and erratic speeds may be caused with oil upon belt or idler wheels. Check the motor belt for cracked areas or too large for slow speeds.

BUDGET PROJECTS

Clean off the pressure roller. Check the bearing for old grease or dry bearings. Often, you may hear a low squeaking noise with the tape operating when the pressure roller bearing is dry. You may find excess tape down on either side of the pressure roller producing slow speeds. Remove the excess tape. Sometimes the pressure roller may be found frozen and will not rotate. Replace the pressure roller assembly if it will not clean up after lubrication.

The portable cassette player may run slow with low voltage applied to the small motor. Check the battery and AC operation. If the player operates on AC and not

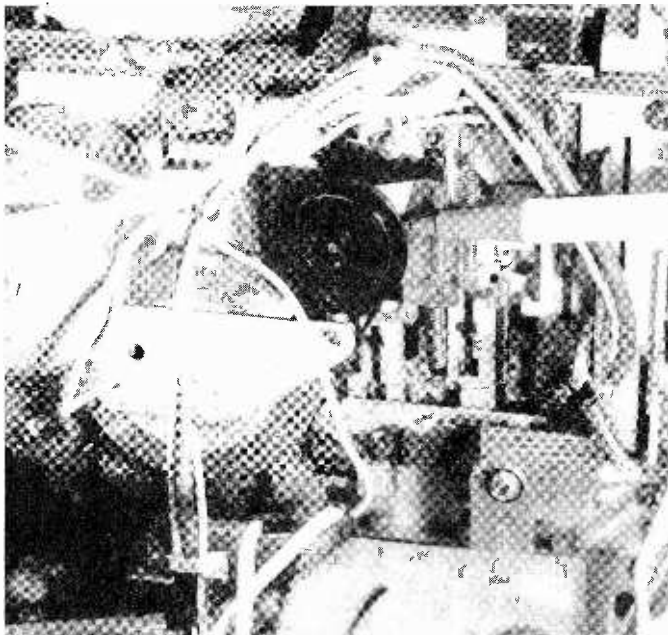

Fig 8. Tape may be pulled from the cassette and the excess wrapped around the capstan when the take-up reel does not rotate. The belt was off the take-up reel causing tape pulling in the Soundesign 5648 model.

batteries, suspect defective batteries. Do not overlook corroded batteries of pulling down the DC voltage in some models when operating from the power line.

Intermittent or erratic speeds may be caused with a defective motor. If the motor shaft must be rotated by hand to make it run, replace the motor. Oil upon the motor-drive belt may cause erratic playing. A worn or loose motor-drive belt can produce erratic speeds. Correct tension of the spider clutch assembly may eliminate erratic take-up or fast forward operation.

Suspect a defective drive motor if the speed is too fast. Usually, most speed problems with the cassette player are slow speeds. Tap the end of the motor while operating and notice if it slows down to normal speed. Of course, the motor must be replaced if defective. A small amount of excess tape wrapped around the drive shaft of the capstan may cause faster speeds. Check the area before suspecting a defective drive motor.

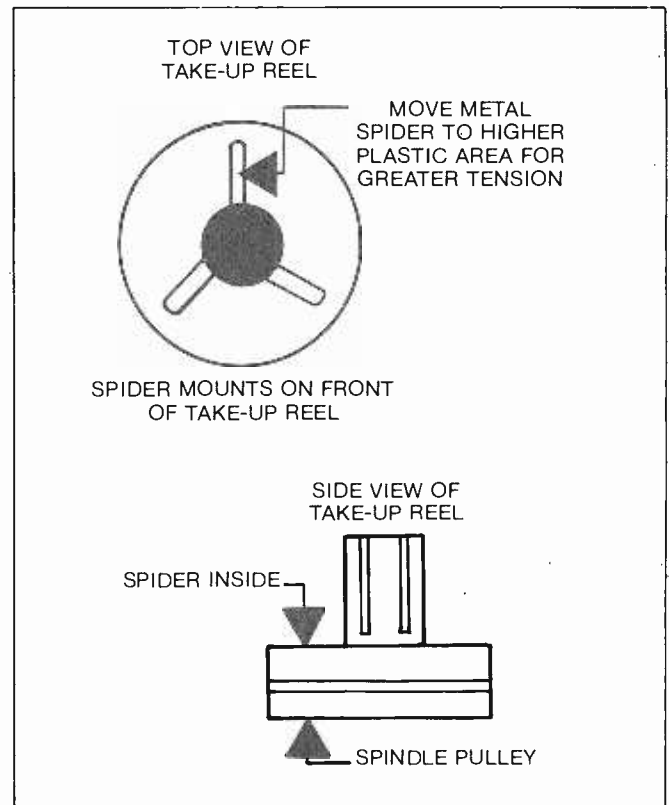

Fig 9. Slippage at the take-up clutch assembly may cause the take-up reel to stop or operate erratically. Rotate the metal spider ring to a higher level upon the plastic for greater tension.

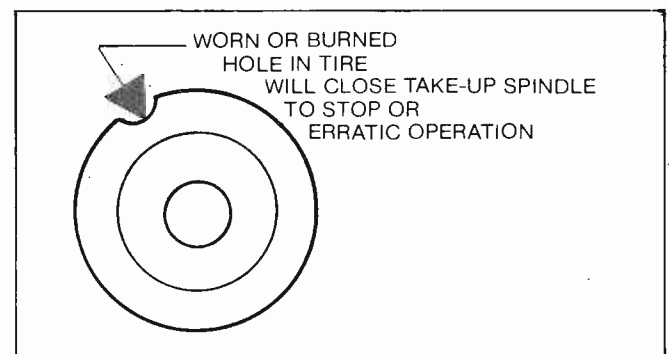

Fig 10. A burned rubber tire may cause the take-up reel to stop. Temporarily repair the rubber wheel with black rubber silicone cement.

Sluggish Take-Up And Fast Forward

Clean up the motor pulley and both spindles for sluggish operation. The tape may play fairly normal in play/record mode but will not reach the required speed for fast-forward mode. If the take-up reel is sluggish, tape may spill out and wrap around the capstan drive area. Check for correct clutch tension at the rear of the take-up spindle. On most models a spider-spring type

BUDGET PROJECTS

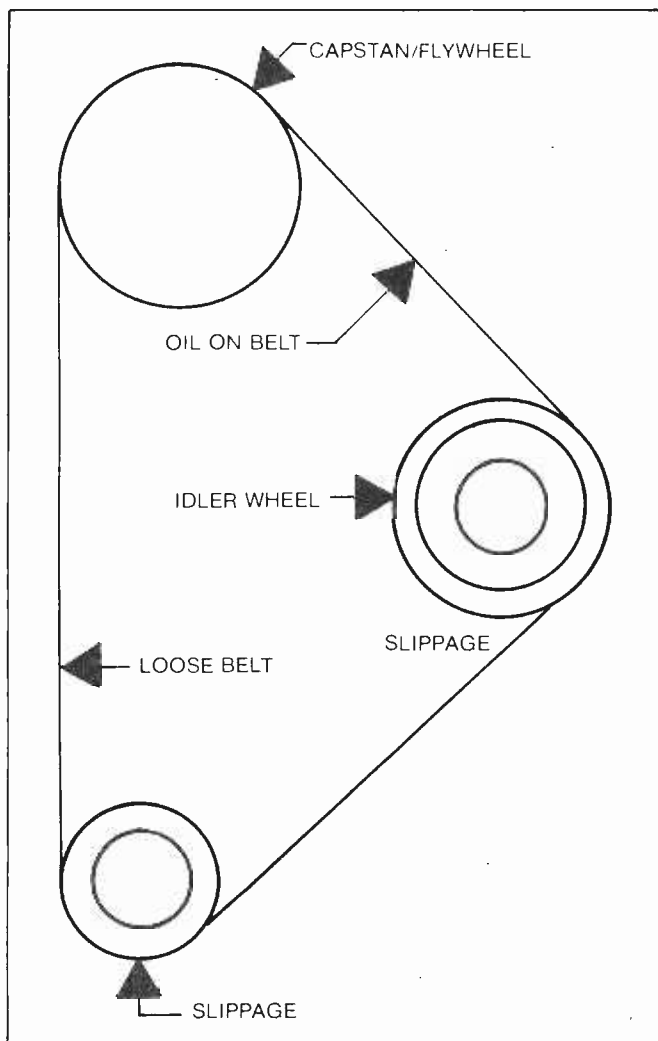

Fig 11. Erratic or improper rewind may be caused with poor tension of the idler pulley. Slow rewind mode may be caused by belt slippage at the capstan/flywheel, idler and motor pulley.

assembly is raised up to a higher level applying more tension for possible slippage at the clutch assembly. Simply rotate the spring to a higher level on take-up reel. The take-up reel may be slowed down with a defective indicator assembly or belt between pulley and plastic bearing.

Pulling And Eating Tapes

No rotation of the take-up reel or spindle will cause the tape to spill out and wrap around the capstan. Check for oil upon the take-up reel belt or a broken belt. Clean up the both spindles. Clean up the clutch assembly, pressure roller and capstan. A dry spindle take-up bearing, and pressure roller, may stop the take-up action. A drop of oil upon the spindle bearings may help. A good clean up and lubrication of all moving parts solve many speed and take-up reel

problems. Resurface the motor pulley, idler wheel and flywheel with a coat of liquid rosin where the motor belt travels for erratic and constant speeds (Fig. 8).

Improper tension at the take-up spindle may cure the erratic movement of tape, letting excess tape wrap around the capstan drive. Some models have a tension-adjustment screw down through a hole at the top of the cassette player. Often, the tension

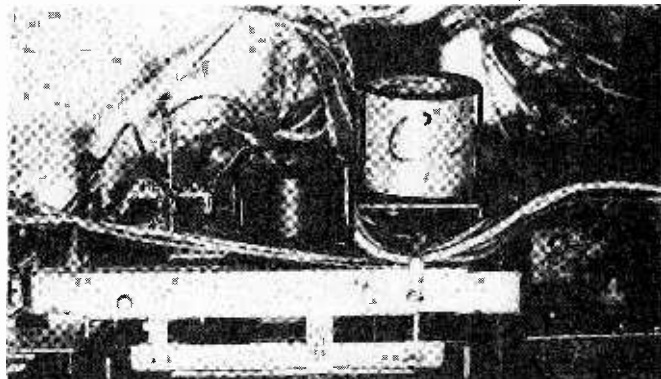

Fig 12. You may find a defective rewind and fast forward motor causing erratic rewind in some models. Here a separate play and rewind motors are located in a J.C. Penny 683-3339D model.

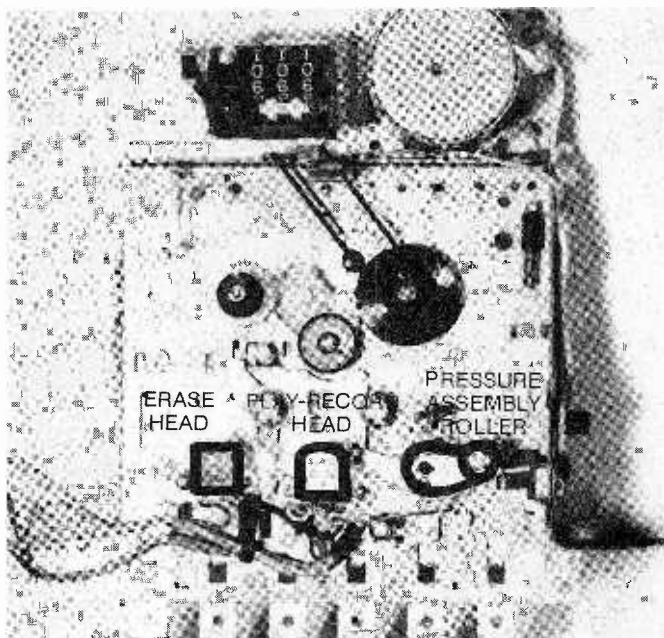

Fig 13. Check the tape-head terminals for open circuit tape head with an ohmmeter. In stereo tape head each tape-head winding should be the same value.

adjustment is a spider ring found on top of the take-up spindle. In some models the adjustment may be made from the front by removing cassette plastic holder or door cover. Remove these small screws holding a metal plate over the idler wheel assembly. Now the spider ring can be seen upon the take-up reel (Fig. 9).

BUDGET PROJECTS

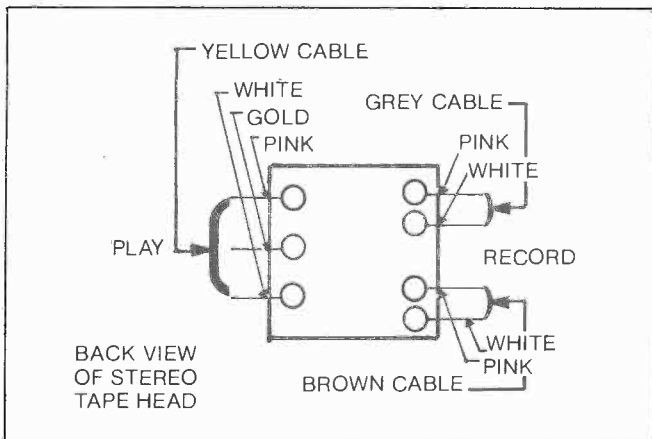

Fig 14. You may find separate stereo record and play windings in one single tape head in some models. Check and compare each channel head resistance against the other to locate the defective tape head.

The erratic take-up reel may operate normally for several minutes and then stop, spilling out tape. Check for a bad belt, worn spindle pulley or rubber spindle pulley with a hole or small area burned out of it (Fig. 10). Sometimes these take-up reels with stop and if left on too long the rubber tire pulley will be gouged out with the small drive shaft. This rubber pulley is at the rear of the take-up pulley. Temporarily repair the rubber pulley with black rubber silicone cement until a new one can be ordered out. Improper seating or a defective cassette may cause the tape to tear or wrap around the capstan.

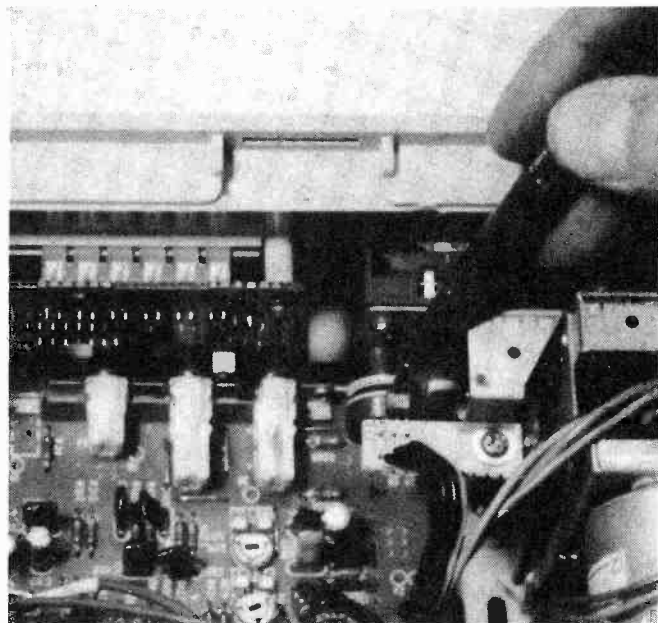

Fig 15. Check for a broken or off-track belt when the tape counter will not advance. The belt may be lodged between plastic pulley and bearing causing the tape counter to not rotate.

No Rewind

Erratic or no rewind may be caused with the idler pulley not engaging play reel assembly, the idler-wheel pulley tension may let the rewind reel slip (Fig. 11). Dress down the idler wheel with liquid rosin to prevent slippage. In some of the larger cassette players you may find two different drive motors. One motor is used for play and record while the other motor operates only in the rewind and fast forward mode (Fig. 12). Check the voltage at the motor terminals with no rewind or fast forward motion. Suspect a defective rewind motor with correct DC voltage at the motor terminal. If no voltage at the motor terminals, check the rewind/fast-forward switch assembly for dirty contacts or broken switch wires.

No Sound—Rushing Noise

Go directly to the tape head when you hear loud rear or rushing noise and no music with tape movement. Suspect a ground or red and white wire broken off at the back of the tape terminals. Sometimes no sound can be heard when the tape head does not meet the tape area. In stereo cassette players one channel may have a loud rushing noise and normal music out of the other channel indicating a broken tape head connection. Notice if the tape head is broken off the mount or loose and tilted away from the passing tape. A loud rushing noise may result from an open tape head winding.

Remove the tape deck cover or remove the tape deck from the cabinet to get at the tape heads. Visually
(Continued on page 94)

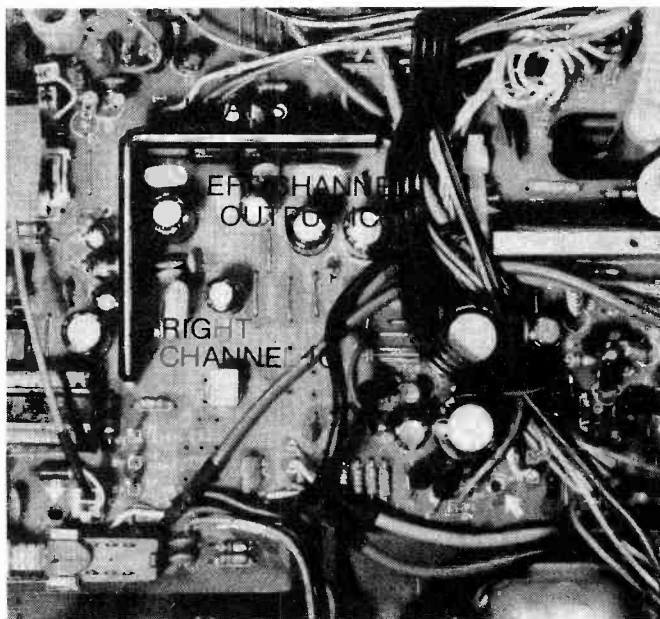

Fig 16. A defective output IC component may produce no or distorted sound in the output circuits. Her two separate IC output components are bolted to the same flat heat sink.

A BASIC COURSE ON MAGNETISM

A basic primer on those mysterious lines of force that lift weights, orient compasses, tune radios and make modern day communications possible.

In a district in Asia Minor known as Magnesia, the ancient Greeks noticed that a lead-colored stone had an attraction for small particles of iron ore.

The ancient Chinese made use of this stone in their desert travels. They suspended the stone or floated it on water and called it *loadstone*, meaning "leading stone." Loadstone (also spelled *lodestone*) is a natural magnet because it possesses magnetic properties in its natural state. At the present time, the most common method of producing electricity is through the use of the magnetic properties of certain materials.

Magnets manufactured today are much stronger than the loadstone. Iron, cobalt, and nickel are used in the manufacture of artificial magnets. Iron is easy to magnetize, but loses its magnetic properties almost immediately after the magnetizing force is removed. Steel is harder to magnetize, but it holds its magnetism over a greater period of time after the magnetizing force is removed.

The Chinese learned that when the loadstone was suspended, or when it was floated on a liquid, one end of the stone always pointed in a given direction. Today we know that any magnetic or magnetized material, when suspended on a pivot or string or floated, aligns itself with the earth's magnetic field. The end of the magnet or magnetized material that points toward the north pole of the earth is called the "north-seeking" pole or "north pole"; the opposite end is called the "south-seeking" pole or "south pole."

It's Inside the Atom

Magnetism is more pronounced in iron and its alloys than in most other materials. Take a close look at an atom of iron diagrammed in Fig. 1. The majority of electrons in orbit around the nucleus appear to be traveling in the same direction. This is the first clue as to why certain materials are easy to magnetize while other materials are almost impossible to magnetize. If you could take a close look at the atoms in a material that cannot be magnetized, you would see that the

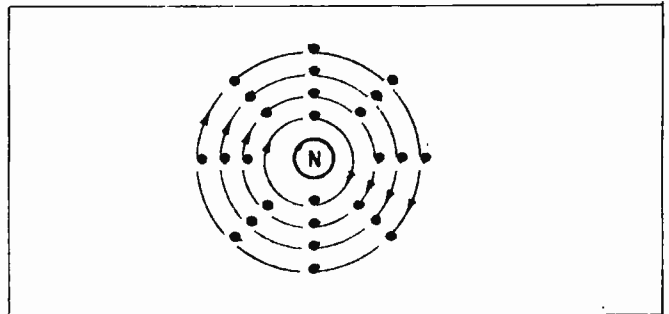

Fig. 1. A two-dimensional drawing of an atom of iron showing the nucleus and orbiting atoms. The diagram is not to scale.

electrons in orbit appear to be traveling in different directions; thus, they will cancel out each other's magnetic effects, preventing any external magnetic field.

Molecular Theory

If you were able to view the molecules inside a block of unmagnetized iron, you would see the total disarrangement of the molecules. Each molecule within a bar of iron.

Another way to magnetize an iron bar is to apply a magnet at the center of the bar and stroke in one

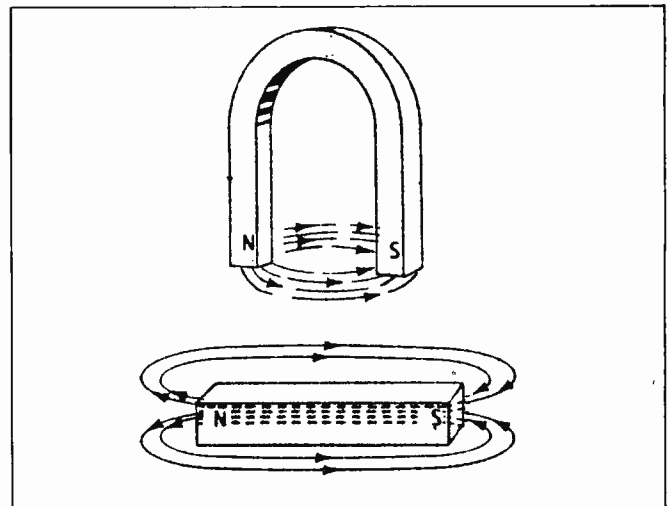

Fig. 2. The arrows show the path of force lines from the north pole to the south pole taking the least possible path length.

The editor of *ELECTRONICS HANDBOOK* present here a brief compact course in magnetism. No one basic course can be complete but this course will at least give the reader a better understanding of the fundamentals of magnetism. Much of the material for this course was taken from the Howard W. Sams Co. title: "Basic Electricity/Electronics" (Volume 2) which, unfortunately, is no longer being printed. However, we extend our gratitude to the Howard W. Sams Co. for granting us permission to reprint this material for our readers.

direction. After half of the bar is magnetized, reverse the magnet and, again starting at the center, stroke the iron bar in the opposite direction.

The Force

Magnets have invisible force lines surrounding them. These lines leave the north pole of a magnet, form a loop, and enter the south pole of the magnet, completing the loop inside the magnet. These loops run parallel to each other inside the magnet and never cross or unite. See Fig. 2.

The lines formed by the magnetic loops are called *magnetic lines of force*. The area occupied by these lines is called *the magnetic field*. The magnetic field is the induced energy surrounding the magnet or the space through which the influence of these magnetic lines of force can be measured. The strength of the magnetic field is measured by determining the number of magnetic lines of force per unit area surrounding the magnet.

More on Poles

The path of magnetic lines of force can be controlled. The lines of force concentrated at the poles of the magnet are much closer together than those surrounding the magnet. This is true because magnetic lines of force always take the path of least opposition. Iron or steel offers less opposition to these lines of force than air or other nonmagnetic material. This principle can be used to advantage. If an iron or steel ring is placed around a watch, the magnetic lines of force will follow a path through the ring and will not pass through the watch. This method of diverting magnetic lines of force is called *magnetic shielding*.

The minimum number of poles a magnet can have is two—a north-seeking pole and a south-seeking pole. It is possible, however, for a magnet to possess more than two poles. The poles between the ends of a magnet are called *consequent poles*. Notice that there are magnetic fields existing between the consequent poles and the end poles (Fig. 6-11). These fields are the same as the field that exists between the end poles. The magnetic lines of force leave a north-seeking pole and enter a south-seeking pole.

There are two types of magnets—permanent and temporary. As their names imply, one magnet retains its magnetism for a long period of time (years in some cases), and the other loses its magnetism almost as soon as the magnetizing force is removed. Manufactured magnets are called artificial magnets since the only natural magnet is the loadstone. Incidentally, a loadstone is very weak compared to a manufactured magnet; therefore, a loadstone has few commercial applications.

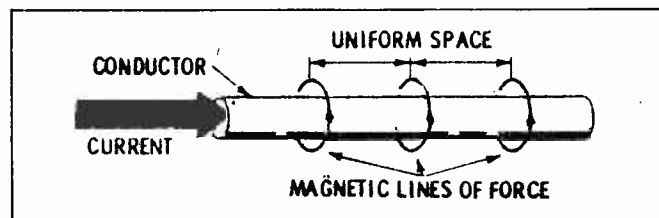

Fig. 3. Flux lines develop around a conductor when current passes through it. The direction of the magnetic lines is determined by the direction of current flow.

Flux

Some materials offer more opposition to magnetic lines of force than do others. In magnetic circuits, this opposition is called *reluctance*.

There is a magnetic circuit (like an electrical circuit) in which the magnetic lines of force form closed loops, called *flux loops*. The force that produces these flux loops is called the *magnetomotive force (mmf)*. The opposition to the flux loops is called *reluctance*. Notice the similarity to the electrical circuit. In a magnetic circuit, the magnetic lines of force always take the path of least reluctance. This is why the magnetic lines discussed previously followed the steel ring around the watch. The steel ring offered less reluctance than did the air and the nonmagnetic metal of the watch in the center of the ring.

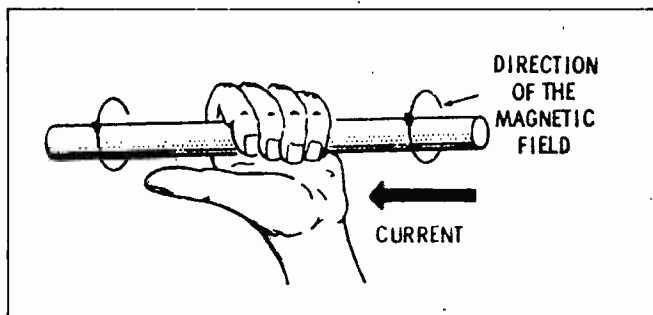

Fig. 4. Using your left hand, align the thumb with the current flow and the finger ends will indicate the direction of the magnetic field.

Magnetic Flux

An expression for determining the amount of flux present in a magnetic circuit is:

$$\text{flux} = \frac{\text{magnetomotive force}}{\text{reluctance}}$$

Flux varies directly with the magnetomotive force and inversely with the reluctance. This is the Ohm's law expression for magnetic circuits. Compare the two formulas.

$$\text{Current} = \frac{\text{electromotive force}}{\text{resistance}}$$

Magnetic flux is the total number of magnetic lines existing in a magnetic circuit or extending through a specific region. The symbol for magnetic flux is the Greek letter ϕ (phi). One magnetic line of force is equal to 1 *maxwell*.

The concentration of these magnetic lines determines the *flux density*. The symbol for flux density is B , and the unit of measurement is the *gauss*. One gauss is flux density of one line of force per square centimeter.

The degree of flux density between the poles of a horseshoe magnet is directly proportional to the area of the air gap between the poles. The force of attraction or repulsion between the poles varies directly with the strength of the poles and inversely with the square of the distance separating them. This force can be determined as follows.

$$F = \frac{P_1 \times P_2}{\mu d^2}$$

where,

F is the force between poles in dynes (unit of force),

P_1 and P_2 are the strengths of the two poles,

d is the distance in centimeters between the poles,

μ is a constant that depends on the medium between the poles. It is 1 for air, and greater than 1 for other mediums.

To find the total number of flux lines, multiply the flux density (in gaussses) by the area (in square centimeters).

Certain materials have more oppositions (reluctance) to magnetic lines of force than others. It is therefore true that some materials allow magnetic lines of force to pass more easily than others. The ease with which magnetic lines of force pass through a material is known as *permeance*, the reciprocal of reluctance.

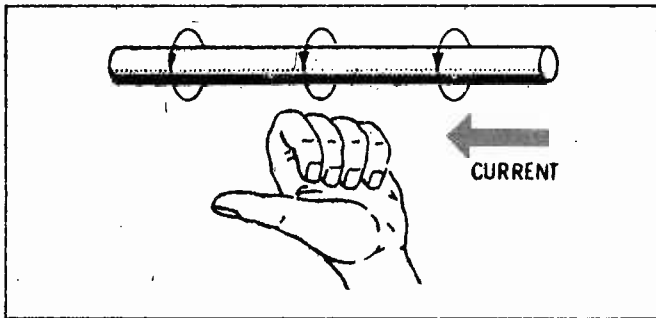

Fig. 5. Using the left-hand rule without touching the conductor.

$$\text{permeance} = \frac{1}{\text{reluctance}}$$

Any substance that allows the magnetic flux to pass with little or no opposition is said to have a high *permeability*. Iron, for example, has a high permeability. High-permeability materials can be easily magnetized, but they will not retain their magnetism. Permeability varies with the intensity of the magnetic field in which the material is located.

It is also possible to determine the flux in any material by multiplying the magnetomotive force by the permeance.

$$\text{flux} = \text{mmf} \times \text{permeance}$$

Not all materials can be magnetized. Actually, materials can be broken down into three classifications—diamagnetic, paramagnetic, and ferromagnetic. *Diamagnetic* materials are those that normally cannot be magnetized. A diamagnetic material is extremely difficult to magnetize and has a permeability of less than 1. *Paramagnetic* materials are those that are difficult to magnetize. They have a permeability of slightly greater than 1. Ferromagnetic materials are those that are relatively easy to magnetize, their permeability is quite high. Some ferromagnetic materials are iron, cobalt, nickel, silicon steel, and cast steel.

Making Magnets

There is another type of magnet that has a wide range of applications in electricity. This is the *electromagnet*. An electromagnet is a bar of soft iron

that will become a temporary magnet if an electrical current is caused to pass through a wire that is coiled around it.

Electromagnetism was first discovered by Hans C. Oersted, a Danish scientist, in 1820. Oersted found that a needle placed near a wire would deflect when current passed through the wire. Further experiments led to the discovery that current flowing through a conductor creates a magnetic field about the conductor (Fig. 3). This magnetic field is composed of lines of flux (magnetic lines) that encircle the conductor at right angles to the flow of current. The flux lines are uniformly spaced along the length of the conductor.

This is another method of creating a magnet. The magnetic field around a straight conductor is not very strong, but it exhibits the same properties as the bar or horseshoe magnet discussed previously. If a compass is placed near the conductor, the compass needle is deflected at right angles to the current-carrying conductor. The compass also indicates that the magnetic field around the current-carrying conductor is polarized. If the current is reversed through the coil, the position of the compass needle also reverses. The magnetic field around a conductor diminishes with an increase in distance from the conductor.

Left-Hand Rule

To determine the direction of the magnetic field around a current-carrying conductor, grasp the conductor in your left hand, with your thumb pointing in the direction of the current flow. The direction that your fingers curl around the wire indicates the direction of the magnetic field (Fig. 4). Do not try this experiment using a bare wire. Place your left hand in a position next to the wire with your thumb pointing in the direction of current flow (Fig. 5). Your fingers will indicate the direction of the magnetic field.

Magnetic Field Strength

Magnetomotive force is the force that tends to drive the flux through a magnetic circuit. The unit of magnetomotive force is the *gilbert*. The unit of measurement used to express field intensity is the *oersted*. The strength of the magnetic field can be found by using the following expression:

$$H = \frac{I}{5d}$$

where,

H is the field intensity at the point nearest the wire in oersteds,

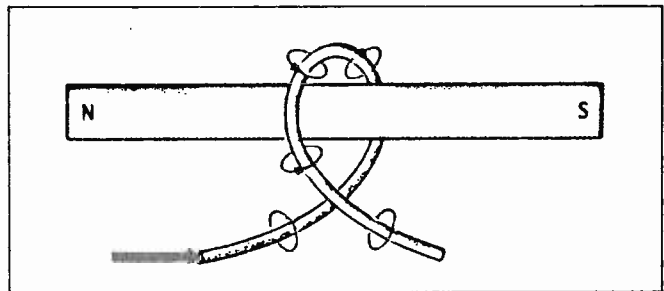

Fig. 6. Current flow through a coil can induce a piece of iron to become a magnet.

I is the current through the wire in amperes,
 d is the distance of this point from the axis of the wire
in centimeters (1 inch = 2.54 centimeters).

Constructing an Electromagnet

The magnetic field developed around a straight wire or conductor is seldom strong enough to be useful. However, if the wire is formed into a coil, the magnetic field becomes quite strong. Fig. 6 shows the action that takes place when current flows through a coil. All of the magnetic lines of force enter the coil at one end and emerge at the opposite end. The strength of the magnetic field is directly proportional to the number of turns in the coil and to the current passing through

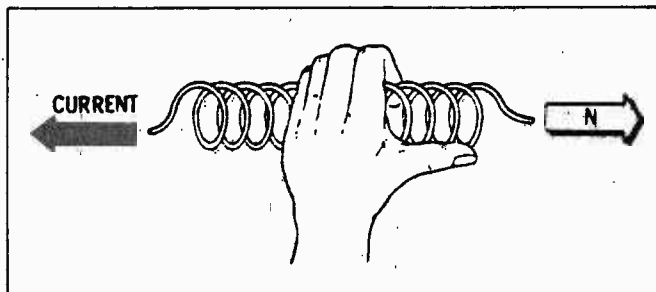

Fig. 7. Determining magnetic polarity using the left hand.

them. A coil with a large number of turns has a magnetic field of greater strength than one with a small number of turns. The magnetic field is greater when a larger current flows through the coil.

Since all magnetic lines of force form a loop, poles similar to those of a permanent magnet are established on the coil. The poles form at each end of the coil and their polarities depend on the direction of current flow.

The left-hand rule is employed to determine the magnetic polarity (Fig. 7). Grasp the coil in your left hand with your fingers pointing in the direction of current flow. Your thumb points in the direction of the north-seeking pole of the coil.

It was stated previously that the flux density is much greater in a block of iron than it is in air. Therefore, if an iron core is added to the current-carrying coil, the magnetic loops will concentrate through the core, increasing the flux density and strength of the electromagnet. The magnetic lines around the coil are called *induction lines*. Soft iron cores are used in electromagnets because of the high permeability of iron.

The strength of an electromagnet can be determined by connecting a coil across a battery and placing an iron rod, suspended by a small hand scale, near the coil. When the circuit is energized, current flows

through the coil, and the magnetic field that is developed attracts the iron rod. The amount of pull can be read directly on the hand scale after subtracting the weight of the rod.

If the overall length of a coil is less than its diameter, the strength of the field can be calculated by the following expression.

$$H = \frac{2\pi NI}{10r}$$

where,

H is the field intensity in oersteds,
 N is the number of turns in the coil,
 I is the current through the coil in amperes,
 r is the radius of the coil in centimeters,
 π is a constant equal to 3.14.

The two main factors that determine the strength of an electromagnet are the current and the number of turns in the coil. The magnetic field can be varied by altering either factor. The combination of these two factors (I and N) is called *ampere turns*. An electromagnet, with 200 turns of wire through which 1 ampere of current is flowing, has a field strength that is equal to an electromagnetic with a 10-turn coil through which 20 amperes of current is flowing. In both cases, the number of ampere turns is 200.

Magnetomotive Force

Magnetomotive force is defined as the force that produces a magnetic field, and is measured in *gilberts*. In the design of an electromagnet for a particular application, it is often desirable to determine just how much magnetomotive force is required in order to create a magnet with a specific field strength. A convenient method of determining the magnetomotive force in a current-carrying air-core coil is to use the following expression.

$$\text{mmf} = 1.257 \times I \times N$$

where,

mmf is the magnetomotive force in gilberts,
 I is the coil current in amperes,
 N is the number of coil turns.

The reluctance of air is 1.257 (this number will be different for an iron-core coil). As can be seen, magnetomotive force is directly proportional to the ampere turns.

Residual Magnetism

When an electromagnet is de-energized, the

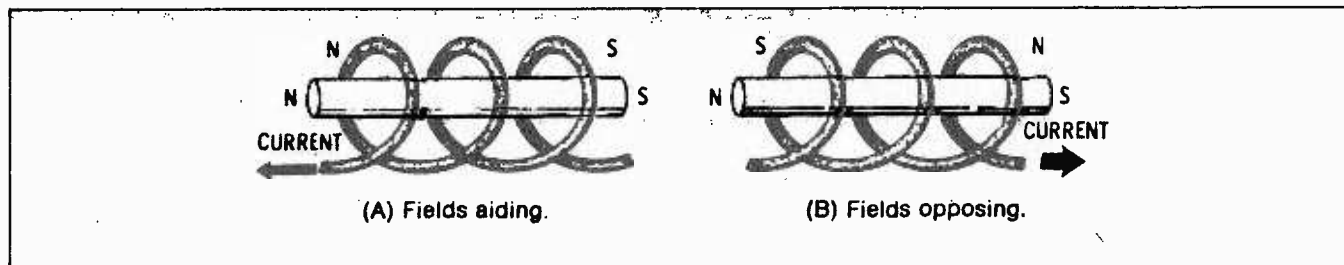

Fig. 8. Current in an electromagnet and how the magnetic fields (A) aid and (B) oppose each other.

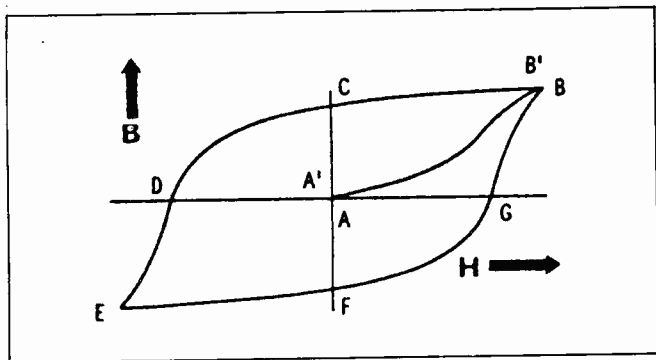

Fig. 9. A typical B-H curve for magnetic material.

magnetic field collapses, but a slight amount of magnetism remain in the core material. This is called *residual magnetism*. When the magnetic lines of force surrounding the coil are concentrated inside the center of the coil, the force magnetically aligns the molecules in the core material. This is similar to magnetizing a metal bar. If the core material is a bar of steel, the results will be different from those for a bar of iron. Once the molecules are aligned in a steel bar, they tend to remain aligned. The core will then retain considerable residual magnetism after the current has ceased to flow through the coil.

Hysteresis

If the current is reversed in an electromagnet (perhaps many times a second), the magnetic field and the direction of polarization will also reverse. If the core material possesses any residual magnetism, the polarity change in the magnetic field will be somewhat delayed beyond the time when the current is reversed. The residual magnetism must be overcome before the core can be magnetized in the reverse direction.

When current flows through the coil in Fig. 8, in the direction shown, the north pole of the magnet is on the left, and the south pole is on the right (left-hand rule for a coil). The magnetic polarity of the core material is identical to the polarity of the coil. When the circuit is de-energized, the magnetic field collapses. Any residual magnetism remaining in the circuit retains its original polarity.

If the current through a coil is reversed, the magnetic field also reverses. Before the reverse magnetic field can build up, however, it must first overcome the residual magnetism in the core material of the coil. The residual magnetism opposes the new field, so it is first necessary to reduce the residual magnetism to zero before the new field can be developed. Instead of the magnetic field being developed immediately as the current increases, there is a slight delay. The magnetic field lags the current slightly. This lag is called *hysteresis*.

Energy is required to align the molecules in the core material. If the current through the coil is reversed frequently, considerable energy is required to realign the molecules first in one direction and then in the other. This energy is lost in the form of heat and is called *hysteresis loss*. The hysteresis lag becomes quite evident when a curve of magnetizing force (H) is plotted against flux density (B).

The curve in Fig. 9 is referred to as a *B-H curve*. When current flows through a coil, the magnetic field around

the coil builds up, as indicated by line A'-B'. When the current reaches its maximum level, the magnetic field also reaches maximum intensity, as indicated by point B. When the current ceases to flow, the magnetic field collapses along line B-C. When the current reaches zero, the amount of residual magnetism remaining in the circuit is indicated by line A-C.

If the current is reversed in the circuit, the residual magnetism must first be overcome. It falls to zero, as indicated by line C-D. The magnetic field then builds up in the opposite direction along line D-E, reaching maximum concentration at point E. When the current stops flowing in the reverse direction and falls to zero, the magnetic field collapses along line E-F. The distance between point A and F indicates the amount of residual magnetism remaining in the core at that time. If the current were to flow in its original direction, the magnetic field would collapse to zero, as shown by line F-G, and build up to its maximum level along line G-B.

Saturation

The magnetic field develops gradually as the current increases. There is a point, however, where the core material cannot accommodate additional lines of flux. When this point is reached, the cores is said to be

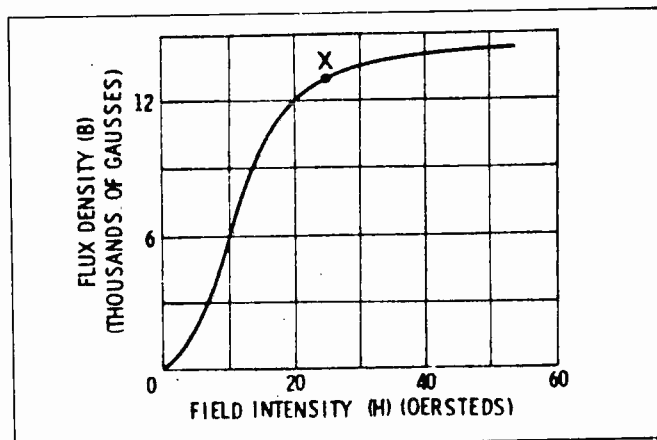

Fig. 10. Magnetizing force and flux density in a steel bar.

saturated. Any additional lines of force will have to flow through the air surrounding the core material. Since the reluctance of air is quite high compared to the reluctance of iron, it is difficult to increase the flux density beyond core saturation.

Magnetic Permeability

Compare the B-H curve in Fig. 9 with the curve in Fig. 10. Notice that the first curve does not vary in a linear fashion along line A-B or A'-B'. This is true because there is a slight variation in the process of core magnetization. Theoretically, the magnetic field gradually builds up by a definite quantity whenever the magnetizing force is varied by a specific amount.

For example, if the magnetizing force increases by 3 oersteds, the magnetic flux increases by 10,000 maxwells. This is true anywhere along the theoretical curve. In actual practice, however, there is a slight variation. At certain points along the curve, an increase of 3 oersteds in the magnetizing force may increase the magnetic flux by only 9800 maxwells. At other points

on the curve, such an increase in the magnetizing force may increase the magnetic flux by 10,300 maxwells. This variation accounts for the nonlinearity of line A-B on the B-H curve.

The graph in Fig. 10 compares magnetizing force and flux density when a steel bar is magnetized. The flux density increases rapidly with only a slight increase in the magnetizing force when the core material is at point of low field intensity (only a few thousand magnetic lines of force). At point of high field intensity, a large change in the magnetizing force is required to cause a small change in flux density. Point X indicates the point of saturation.

Permeability can be determined by the following expression.

$$\mu = \frac{B}{H}$$

where,

μ is the permeability (has no unit of measure),
 B is the flux density in gausses,
 H is the magnetizing force in oersteds.

When the permeability of a material is low, the reluctance is high, requiring a large magnetizing force to increase the flux density. This can be seen from the following expression for determining flux.

$$\phi = \frac{mmf}{R}$$

where,

ϕ is the flux lines in maxwells,
 mmf is the magnetomotive force in gilberts,
 R is the reluctance.

Solenoids

A coil wound in the shape of a cylinder or tube is called a *solenoid*. A solenoid is often provided with a movable iron core, or plunger. In this arrangement, the iron core is pulled into the coil when current flows through the turns. Thus, the core can be used to mechanically move some device.

Solenoids are commonly used in relays or circuit breakers. The magnetic field built up in the center of the coil pulls the core into the solenoid, thereby breaking or making the relay contact(s).

Toroids

Another type of coil that is used in some applications

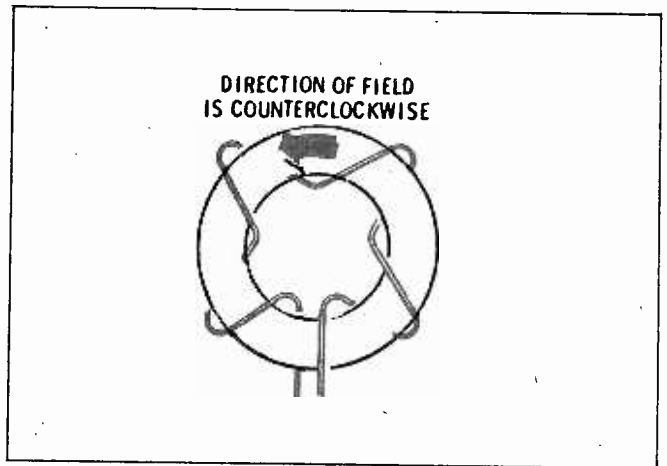

Fig. 11. The magnetic material is in the form of a toroid with wire wrapped as shown.

is the *toroid*, which has a ring-shaped core on which the turns of wire are wound to form a complete circle. This design concentrates all the lines of force inside the ring. Thus, with all the flux inside the ring, the toroid has no external polarity. See Fig. 11.

Polarized Electromagnets

A polarized electromagnet has a permanent magnet as its core, as shown in Fig. 12. When current flows in the coil, the electromagnet will either add to, neutralize (cancel out), or subtract from the magnetic field of the permanent magnet. Polarized electromagnets are used in telephone and telegraph circuits.

What's Next

As the study of magnetism advances into more complex areas we find that the subject matter comes under more fitting headings like AC and DC motors, AC and DC generators, tuned coils, inductance, radio, and beyond.

We did not provide all there is to know about magnetism in this issue, for to do so would require several volumes. We covered the basics.

Should you desire to continue expanding your electronics knowledge, continue reading this magazine. Also, since all of the material in this article may be to your liking, we admit that it came from basic electronics publications published by Howard W. Sames & Co., Inc. 4300 West 62nd Street, Indianapolis, IN 46268. Write to them requesting that they send to you this book catalog. Many of their titles are suited just for you!

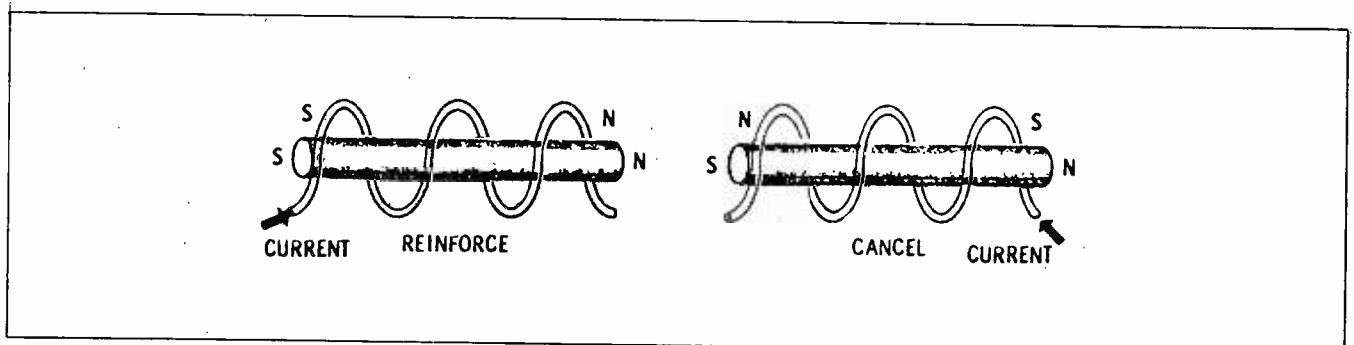

Fig. 12. The effect a coil carrying current has on an electromagnet.

CIRCUIT FRAGMENTS

CIRCUIT FRAGMENTS THAT DO THINGS

By Curt Sim

The design of projects usually takes the form of an idea and a circuit fragment. The fragment is usually a circuit that is complete in that it does something all by itself, however, it can be expanded to do bigger and better things. This article will present some circuit fragments that are useful projects in themselves. Nevertheless, with a little thought, these circuits can be made part of a larger project that provides many more useful functions or improved performance.

The parts used in these circuits are common and may be available in your spare-parts box. The use of a solderless breadboard will give you an opportunity to play with each circuit without damaging the parts or leads from constant soldering and desoldering. The experience you obtain will be invaluable in future projects...Enough chit chat—on with the projects!

SIMPLE COIN TOSS

For just the price of a pushbutton switch (S2 in Fig. 1), an ordinary multivibrator circuit can be converted to something else, and you can flip electronic coins as long as you want until the battery drains dead! When the button of S2 is depressed, the circuit is a squarewave multivibrator running at about 800 Hz. Release the button and the circuit becomes a stable

one shot-device that has only one transistor conducting. Under this condition, one of the light-emitting diodes (LED1 and LED2) will be on. The symmetry of the circuit indicates that the 800-Hz squarewave will have a 50-percent duty cycle. That is, the squarewave will be high for one half of the time, and low for the remaining half. Thus, when S2 is released,

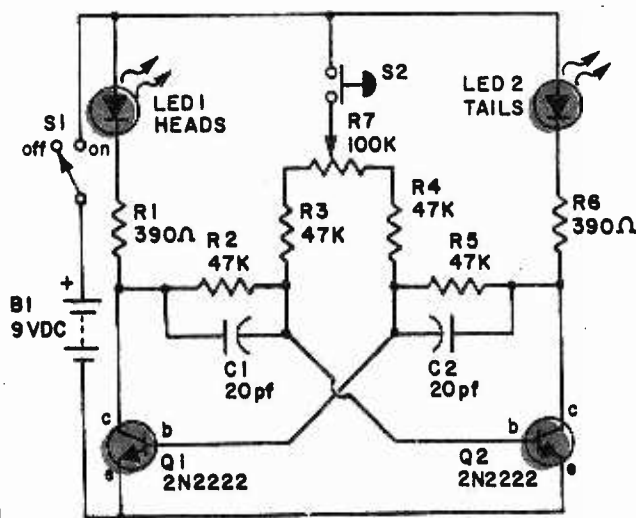

PARTS LIST FOR SIMPLE COIN TOSS

- B1—9-volts DC, transistor-radio battery
- C1, C2—22-picoFarad disk capacitor
- LED1, LED2—Light-emitting diode, 20 mA, one red, one yellow or green
- Q1, Q2—2N2222, 2N2222A or BC108 PNP audio-switching transistor
- S1—SPST, on/off switch (any suitable type will do)
- S2—Normally-open, single-pole, pushbutton switch (All fixed resistors are 5%, 1/4-watt fixed units unless otherwise indicated)
- R1, R6—390-ohm resistor
- R2—R5—47,000-ohm resistor
- R7—100,000-ohm linear-taper potentiometer

Fig. 1. This free-running multivibrator switched the LED1 AND LED2 "on" and "off" alternately when S2 is closed. When S2 opens, only one light-emitting diode remains illuminated.

CIRCUIT FRAGMENTS

the transistor that was on will continue to conduct.

You could expect 50 heads for every 100 "tosses!" But, that will only occur when potentiometer R7 is so set that all unbalances in the circuit are equalled. With R7 set to some unbalance, the number of heads versus tails will be other than 50-50. The device could be adjusted for 60-40 splits, or other desired ratios. Don't try this with friends who become upset when they discover that you hoodwinked them!

If you want to slow down the free-running frequency to as low as one Hertz or less, increase the value of C1

and C2 equally to 10 microFarads. Of course you will be able to see the light-emitting diodes switch on an off so that releasing S2 can control the indication read out of either heads or tails. In this case, use a remote switch so the player cannot see the readout until after he releases the switch.

Potentiometer R7 may be any taper type, but linear potentiometers are best. Values from 50,000- to 100,000-ohms may be used. If you wish, two series 50,000-ohm resistors may replace R7. The center tap connects to S2.

FET AWAY TIME

Why is it that whenever a timer circuit is required the IC is called to do the task even when simpler ways are available? By that we mean, take a gander at Fig. 2 for the FET Timer and compare it to any other circuit using a chip. Which one is simpler? Now you know the answer, and you know why the circuit appears here.

Note that the junction FET, Q1, serves as a switch that turns on high-impedance piezoelectric buzzer, Z1. Do not use a mechanical buzzer here for fear that the device's low impedance would burn out Q1.

Using a capacitor, C1, rated at 500- μ F and a 1-Megohm potentiometer, R2, a time delay of more than two minutes is possible. A SPST toggle switch, S1, is kept at the reset position until the timing cycle is to begin. When S1 is set at TIME, C1 discharges through R2. To decrease the delay, reduce the setting

(resistance) of potentiometer R2. When the potential at point A is near ground, the FET will conduct and the piezoelectric buzzer, Z1, will sound until S1 is returned to RESET, or the power is removed.

For much briefer periods, reduce the size of C1 so that the adjustment range of the potentiometer will be in the mid-range position. Resistor R1 limits the current flow through Q1 so that its rating will not be exceeded. Should a mechanical buzzer be used, and it worked, the inductive kick caused by the counter-electromotive force produced by its inductance would destroy the FET. Also, since R1 is required in the circuit to protect Q1, there would not be enough current flow to actuate the buzzer. In other words, stick with the diagram the way it appears!

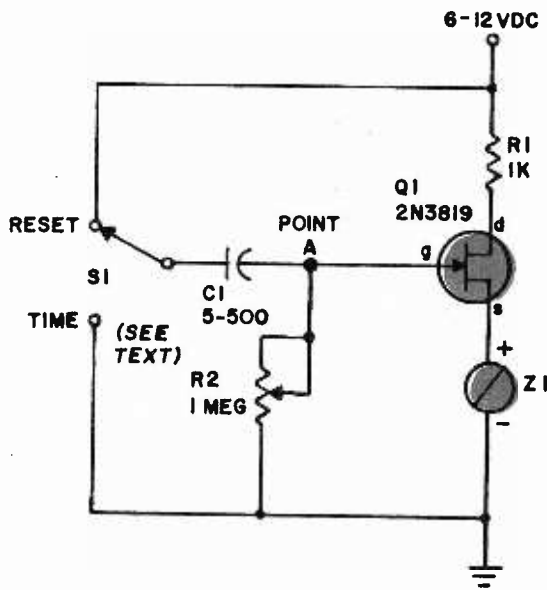

PARTS LIST FOR FET TIMER

- C1—5- to 500- μ F, 16-WVDC, electrolytic capacitor
- Q1—2N3819 junction field-effect transistor (FET)
- R1—1000-ohm, 1/4-watt, 5% resistor
- R2—1-Megohm, linear- or audio-taper potentiometer
- S1—SPDT toggle switch
- Z1—Piezoelectric buzzer (almost any hobby type will work)

Fig. 2. Capacitor C1 charges to the battery potential with S1 at "RESET". Then C1 discharges through the variable resistor, R2.

CIRCUIT FRAGMENTS

BLINKING NEONS

The bow-tie blinker circuit (Fig. 3) was first used by the editor to blink two lights in a bow tie, and we have since seen it used in eyeglasses, ear rings and other personal applications to raise excitement. Lets assume that I1 is on first so that C1 will charge through R2 and I1. When the voltage across C1 exceeds the firing potential of I2, that neon lamp will fire and I1 will be turned off. Now C1 takes a reverse charge through R1 and R2 until the firing potential of I1 is exceeded, causing to fire, and I2 to go off. That cycle will continue

as long as power is supplied to the circuit by B1.

Each lamp will be illuminated for an equal period provided that R1 and R2 are equal in resistive value. This selection is usually preferred. However, you may want to experiment with different timing periods so that different effects may be obtained for special purposes. Vary the resistive value (up and down) of R1 or R2 about ten percent and observe light action.

Why neon bulbs? The main reason is that no amplifier or electronic switching device is necessary.

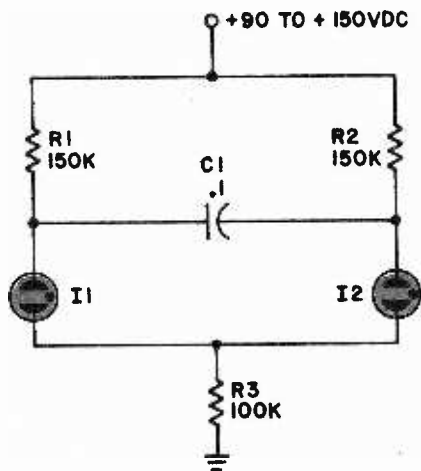

PARTS LIST FOR BLINKING NEONS

- C1— .1- μ F, 200-VVDC ceramic capacitor
- I1, I2— NE-2 neon bulb
- R1, R2— 150,000-OHM, 1/2-watt resistor
- R3— 100,000-ohm, 1/2-watt resistor

Fig. 3. This circuit could be possibly the first electronic multivibrator.

MORE LIGHT

The output of an CMOS circuit may require a visual indicator brighter than a light-emitting diode to indicate a circuit high on a test panel or remote site. However, should you connect a filament lamp directly across the opamp output without regard for the remaining circuit, you most probably would introduce problems that are not tolerable.

The diagram in Fig. 4 shows how a buffered lamp can be connected so that it will cause no problem to the circuit to which it is connected. When a circuit high is present (+5-volts DC) the transistor will conduct and the lamp, I1, IN Q1's emitter circuit will be powered on. Actually, this circuit is a relatively simple logic probe you may want to construct for other purposes.

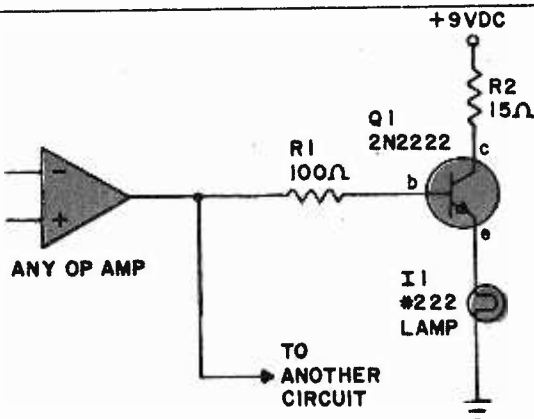

PARTS LIST FOR BUFFERED LAMP

- I1— No. 222 Light bulb
- Q1— 2N2222 NPN transistor
- R1— 100-ohm, 1/4-watt resistor
- R2— 15-ohm, 1/2-watt resistor

Fig. 4. Package R1, R2, Q1, I1 and a 9-volt battery into a hand-held status probe for checking out logic circuits.

CIRCUIT FRAGMENTS

9-VOLTS MOBILE

One big problem with 9-volt batteries is that they often go dead just when you need them most. If you are a highway dictator you record business letters and notes while driving from one business appointment to another, then use the car's power to drive the recorder and save the batteries for those moments when no other power source is available. The car power tap (see Fig. 5) delivers up to 800 milliamperes of regulated 9-volt power from your car's cigar lighter or any power jack you may install.

Just plug in the circuit (see Fig. 5) and a 2N222 NPN

transistor in conjunction with a 9.1-volt Zener diode does all the work. Should you need a bit more than 80 milliamperes, then use a 2N3055 for Q1. Play it safe, be sure to attach either transistor to a heat sink. The heat sink may be a store-bought item or made from a piece of copper sheet approximately 2 square-inches in surface area.

It is always a good idea to include a protective fuse in the circuit. Try one that is about .5 amperes. Stay away from slow-blow types or else you may pop some fuses in the car during an accidental short.

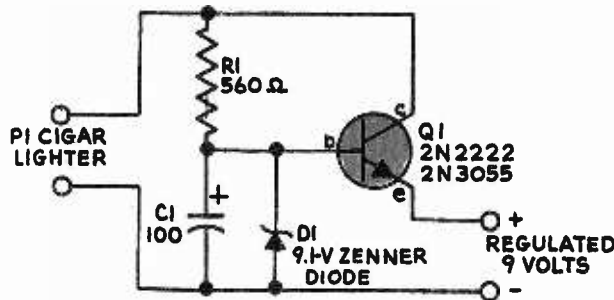

PARTS LIST FOR CAR POWER TAP

- C1—100-uF, 25-WVDC electrolytic capacitor
- D1—Zener diode, 9.1-V at ¼-watt
- P1—Cigar lighter plug
- Q1—NPN transistor, 2N2222 or 2N3055 (see text)
- R1—560-ohm, ½-watt, 10% resistor

Fig. 5. Be careful when you connect the polarized components of this circuit.

MOST POPULAR CIRCUIT

Here is a simple light-activated relay circuit that is sensitive to room light conditions. (See Fig 6.) The light-sensitive device is PR1 a CdS- or CdSe-type photoresistor that is placed in the base circuit of an NPN transistor, Q1. When no, or insufficient, light falls

on the photoresistor, PR1 transistor Q1 is biased to cut-off and the solenoid of the relay, K1, is unenergized.

As light strikes the photoresistor the base current in Q1 begins to flow and Q1 conducts enough current to

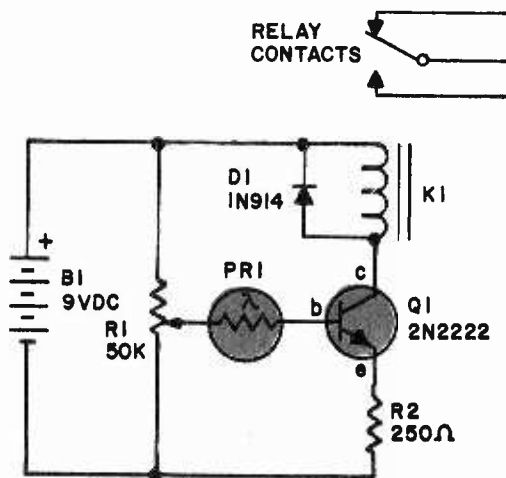

PARTS LIST FOR A MOST POPULAR CIRCUIT

- B1—9-volt transistor battery
- D1—1N914 rectifying diode
- K1—Refer to Radio Shack catalog
- PR1—CdS or CdSe photoresistor (Refer to Radio Shack catalog)
- Q1—2N2222 NPN audio-switching transistor
- R1—50,000-ohm, linear-taper, potentiometer without switch
- R2—250-ohm, ¼-watt resistor

Fig. 6. Direct a beam of light onto PR1 and when it is interrupted the normally-closed contacts can set off an alarm—"a budget alarm system".

CIRCUIT FRAGMENTS

energize the coil of K1, pulling down the relay contacts to the energized position. The contacts are electrically isolated from the circuit, and they can be used to provide control of a circuit using standard line voltages and even high currents. As the light diminishes, the photocell internal resistance increases, reducing the current to the base of Q1 and shutting down the transistor, and the relay.

The relay should be a low-current type so that the normal non-destructive current through Q1 is

sufficient to power on the relay. Relays of this type can be found in Radio Shack's catalog.

Diode D1 eliminates the bucking voltage created by the relay coil when the relay is turned off, thus preventing the destruction of the transistor. Adjust potentiometer R1 so that the circuit actuates at the light level you desire. Also, mask photoresistor PR1 should the light intensity be too high to turn off the circuit at the level you desire.

BATTERY-VOLTAGE MONITOR

Tired of playing guessing games with your batteries? With this battery-voltage monitor (See Fig. 7) you'll know at a glance whether or not batteries need replacement. The circuit's compact size, which comes about because it's a meterless voltage monitor, makes it easy to build into an existing piece of equipment. To use the device, press S1 and, if LED1 lights up, your batteries are still good. If not, get ready to throw them away.

Transistor Q1's gain makes the monitor very sensitive to changes in voltage. Consequently, LED1 is either ON or OFF with little ambiguity most of the time. The voltage level being sensed is determined by Zener

diode D1's rating and the base-emitter voltage drop of Q1. Specifically, the switching point is equal to the Zener voltage plus 0.75-volts. For example, a 5.6-volt Zener diode will set the trip level at approximately 3.35-volts.

The voltage level you choose should be less than the battery's nominal voltage when fresh. A 9-volt battery, for example, might be useless when its voltage drops to 7.5-volts; however, the exact point at which a battery becomes useless depends both on the battery and on the application. Finally, it's best to test the battery with a normal load current being drawn from it by the project or gear.

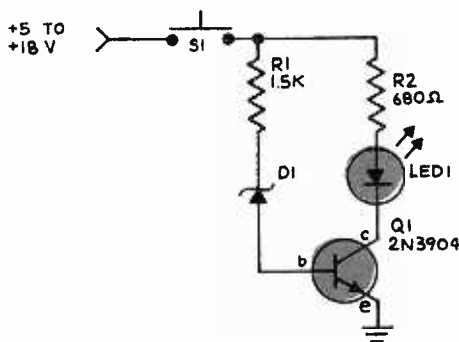

PARTS LIST FOR BATTERY-VOLTAGE MONITOR

- D1—Zener diode (see text)
- LED1—light emitting diode rated 20-mA @ 1.7-VDC
- Q1—2N3904 NPN transistor
- R1—1,500-ohm, 1/2-watt, 5% resistor
- R2—680-ohm, 1/2-watt, 5% resistor
- S1—Normally open, SPST pushbutton switch

Fig. 7. Be sure to use a pushbutton switch for S1, otherwise the circuit will slowly drain the battery during down time.

LED DISPLAY

Who said you need an IC chip to operate a LED-bar graphics display? The diagram in Fig. 8 takes advantage of the forward voltage drop exhibited by silicon diodes. Each leg of the circuit shows a light emitting diode in series with a current limiting resistor and a different number of diode voltage drops, from 0 to 5. You may use any kind of diode you wish, including germanium, silicon, even expensive hot carrier types

(although they won't exhibit quite as much drop, they're very expensive, and too large a current could burn them out).

Depending on the diodes you choose, each will exhibit a forward voltage drop between 0.3 and 0.7 volts! For consistency, stay with diodes of the same type, or at least the same family. Those twenty-for-a-dollar "computer" diodes will do just fine. To expand

CIRCUIT FRAGMENTS

the range of this LED "meter," use two resistors as a voltage divider at the input. Connect one across the + and - terminals, the other from the + terminal to the

voltage being measured. The LEDs will then be monitoring a range determined by the ratio of those resistors.

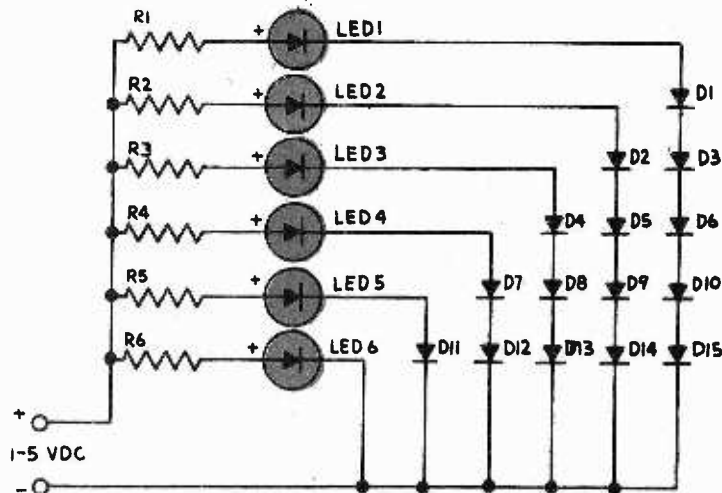

Fig. 8. Resistors R1 through R6 must be the same value. Use 5 percenters! All the light-emitting diodes should be of the same type. The diodes—you guessed it, are all the same type!

PARTS LIST FOR LED-BAR GRAPHIC DISPLAY

D1-D15—Silicon diodes (such as 1N914)
 R1-R6—120-270-ohm resistors, ½-watt (all of the same value)
 LED1-LED6—Light emitting diodes

Summary

You got it, guys! Eight action-packed circuits that almost every experimenter will use in the following year, if not next week.

The "simple coin toss" circuit (Fig. 1) can be coupled with the "light-activated relay" circuit of Fig. 6, so that a bell could be rung every time one of the LED's comes on. What could be done is that an optocoupler could be used to replace, say LED1 in Fig. 1 and Fig. 6.

The "op amp" in Fig. 4 could be replaced with a logic 1 element. For example, an AND circuit can be used so that when two inputs are present at the same time, Lamp 11 will come on. Or, if you use an OR circuit, one or another signal either separately or together will light the bulb.

As for Fig. 5, I'd start building several immediately, because friends will want one as soon as you start using yours.

I could go on hours, but that's the fun you should be having. Start building today. ■

INDUCTANCES & CAPACITANCES

By Jan Drover

The lowly resistor is the solid citizen of electronics. It can be relied upon to behave with the same, predictable performance, whether confronted with AC or DC. Unruffled by excursions into the higher frequencies, it continues to live by the guiding rule—Ohm's law—and declares that, no matter what, the current (I) it permits to flow shall depend solely on the applied voltage (E) divided by its own resistance (R).

However, the resistor's component cousins—the inductor and the capacitor—are by no means so stolid in the face of changing frequencies. The inductor, for example, grouchily shuts off more and more of the current flow as the frequency of the current passing through it gets higher and higher; while the capacitor reacts to higher frequencies in just the opposite manner—it happily allows more and more current to flow as the frequency rises.

Fortunately, the reactionary behavior of these components is just as predictable as is the single-mindedness of their resistive cousin. If we study the strange conduct of these apparently erratic citizens, we not only discover the rules which govern their odd behavior, but also perceive that ultimately, they too, are faithful to Ohm's law—in their fashion—just as are all electronic components and circuits.

Reactionaries in the Lab

To begin our study, let's set up the lab experiment shown in Fig. 1.

Here, we have an audio oscillator set to produce an output of 60 Hz, and a power amplifier to amplify that signal to the 100-volt level. The power amplifier drives a load consisting of a large, 25-watt, 390-ohm resistor connected in series with an ordinary 1½-volt (0.25-ampere) flashlight bulb. An AC meter reads the output voltage from the power amplifier.

Turning on the equipment, we set the audio oscillator to 60 Hz, and gradually turn up the amplifier gain till 100 volts appears at the output. (Note: The ordinary hi-fi amplifier won't do this—you will need a public-address amplifier with a high-voltage (70-volt, or 500-ohm) auxiliary output if you actually want to carry out this experiment.) At this point, the bulb will light to its normal brightness, indicating that the 100 volts is pushing about 0.25 ampere through the combined resistor/light-bulb circuit. Using Ohm's law, we can easily check this:

$$\begin{aligned} I &= E/R \\ &= 100 \text{ volts}/(390 \text{ ohms} + 6 \text{ ohms}) \\ &= 0.252 \text{ amperes} \end{aligned}$$

Note that light bulb's resistance, R, is

$$\begin{aligned} R &= E/I \\ &= 1\frac{1}{2} \text{ volts}/\frac{1}{4} \text{ ampere} \\ &= 6 \text{ ohms} \end{aligned}$$

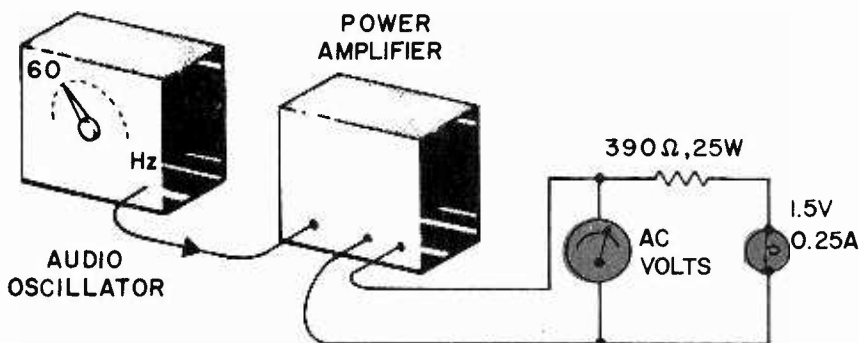

Fig. 1. Practical laboratory setup to demonstrate Ohm's law. Power audio amplifier must have a 70-volt output or a 500-ohm output transformer tap. Ordinary high-fidelity amplifiers cannot be used.

Please also note that it's the 390-ohm resistor, not the bulb, which is the chief authority in establishing the current. The lamp current will change very little, whether the bulb is 6 ohms, 12 ohms, or near zero ohms.

Next let us vary the frequency of the audio oscillator; first down to 30 Hz, and then, up to 120 Hz. We notice that the bulb stays at the same brightness, indicating that the 390-ohm resistor is behaving in its normal, stolid fashion—that is, it is steadfastly ignoring frequency changes, and permitting its current flow to be determined solely by Ohm's law. Even if the frequency were zero (which is another way of saying DC), the bulb's brightness would, remain the same, if we applied 100 volts to it.

Enter the First Reactionary

Now let's go to our parts supply bin, pick up a 1-Henry inductor, and make a few preliminary measurements on it. Using an inductance bridge, we discover that its real value is 1.05 Henry. We next connect it to an ordinary ohmmeter as shown in Fig 2, which informs us that the inductor has a resistance of 45 ohms.

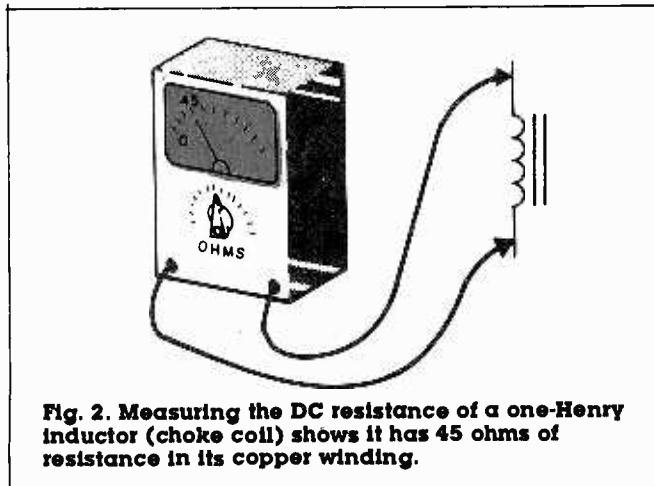

Fig. 2. Measuring the DC resistance of a one-Henry inductor (choke coil) shows it has 45 ohms of resistance in its copper winding.

Now, let us replace the 390-ohm resistor of Fig. 1 with this 1-Henry inductor as shown in Fig. 3, and predict what will happen when we turn on the equipment. Since the ohmmeter said "45 ohms" we can predict that the current will be

$$\begin{aligned} I &= E/R \\ &= 100 \text{ volts}/45 \text{ ohms} + 6 \text{ ohms} \\ &= 1.96 \text{ amperes!} \end{aligned}$$

With this large current—nearly 8-times normal—the light bulb should burn out almost instantly! However, when we apply 100 volts of 60 Hz to the inductor-plus-bulb, we are surprised to see that the bulb lights to normal brightness! This means that the inductor is behaving like a 390-ohm resistor, and is establishing a ¼-ampere flow of current—not the nearly-2 amperes calculated from the above ohmmeter measurement.

To compound the mystery, let us now vary the frequency of the oscillator, first, up to 120 Hz—and the bulb gets dimmer!—and then gingerly, down, just a little, to 50 Hz—and the bulb gets uncomfortably brighter. Here, in the lab, is the actual behavior forecast

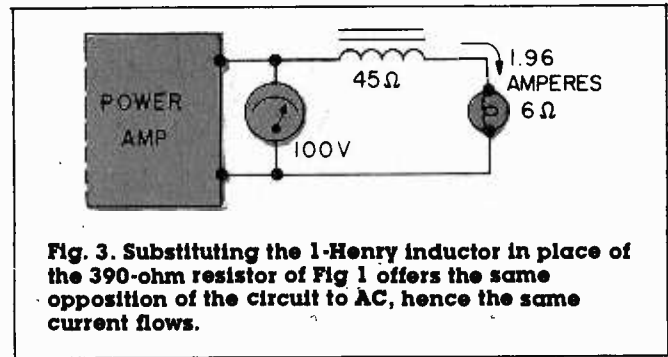

Fig. 3. Substituting the 1-Henry inductor in place of the 390-ohm resistor of Fig 1 offers the same opposition of the circuit to AC, hence the same current flows.

by theory—the inductor grudgingly shuts down the current flow for high frequencies, causing the bulb to go dim at 120 Hz, but it is willing to let low frequencies through, thus allowing the bulb to get brighter for 50-Hz input.

A Little Compassion for the Reactionary

To understand this "reactionary" behavior, we must understand how an inductor "feels" about an alternating current. An inductor is, after all, an electromagnet. If a steady direct current flows through it, it fills the space in its vicinity with a magnetic field.

If we attempt to cut down the inductor's current, it reacts, quite understandably, by collapsing its magnetic field. But this collapsing field moves across the inductor winding in just the same way that a dynamo or generator field moves through the generator windings to make an output voltage. The inductor, then, reacts to any attempt to change its current by acting as its own generator, generating a new voltage of the correct polarity to try to keep its own current from changing. So, in its own way, the inductor is a solid, but conservative citizen—a citizen who tries to maintain the *status quo*.

Furthermore, the faster we try to change its current, the harder the inductor works to keep the current from changing. Therefore, the inductor sees a high frequency as an attempt at rapid changes—a threat to the *status quo*—so it works very hard to generate an opposing voltage (a 'counter-EMF' or 'counter-electromotive-force') to keep its current from changing. This internally-generated voltage opposes the applied voltage more and more as the frequency rises; hence the actual current which flows drops lower and lower as the frequency rises. *This means that the apparent resistance of the inductor rises with frequency.* But this apparent resistance is not called *resistance*—since it is the inductor's reaction to the frequency applied to it, it is called *inductive reactance*.

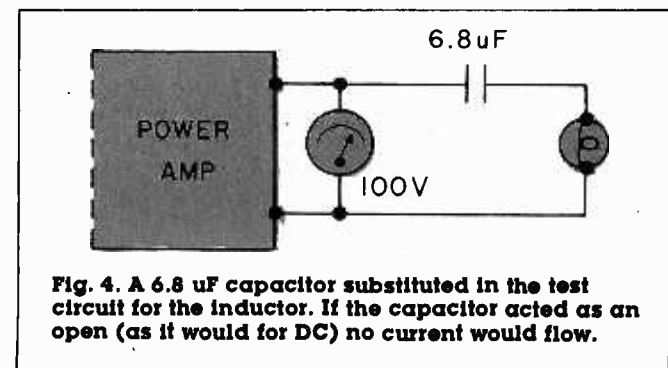

Fig. 4. A 6.8 uF capacitor substituted in the test circuit for the inductor. If the capacitor acted as an open (as it would for DC) no current would flow.

A Resistance by Any Other Name

But whether you call it "apparent resistance" or "inductive reactance", it is still measured in ohms, and can be used as a part of the familiar Ohms law formula. Where a simple resistive circuit answers to the expression.

$$I = E/R.$$

A similar circuit with resistor replaced by an inductor (coil) is described by the formula:

$$I = E/X,$$

where X is the symbol for reactance. But since the amount of reactance (X) changes according to frequency, we must have a way to calculate its value at the frequency we are using. The following simple formula does that for us:

Inductive Reactance = $2 \times 2 \times \pi \times \text{frequency} \times \text{inductance}$ or, in the familiar algebraic shorthand, or

$$X_L = 2\pi fL$$

where, L is the inductance in Henrys, and the subscript L following the X indicates we are talking about *inductive* reactance. Therefore, the current in an inductive circuit is:

$$I = E/X_L \\ = E/2\pi fL$$

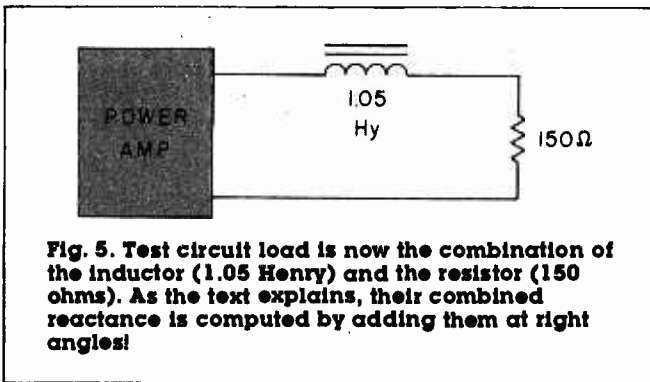

Fig. 5. Test circuit load is now the combination of the inductor (1.05 Henry) and the resistor (150 ohms). As the text explains, their combined reactance is computed by adding them at right angles!

For Example

Let's take the 1.05-Henry inductor and calculate its reactance at 60 Hz:

$$X = 2\pi fL, \\ = 2 \times \pi \times 60 \times 1.05 \\ = 395.8 \text{ ohms.}$$

which, as you can see, is very close to the 390 ohms of the resistive circuit of Fig. 1. This explains why the bulb lit to about the same brightness for the inductor as for the resistor. (This also explains why we selected a 1.05 Henry inductor—we wanted you to see like values in examples.)

When we cranked the audio oscillator up to 120 Hz, the inductive reactance became.

$$X_L = 2\pi fL, \\ = 2 \times \pi \times 120 \times 1.05 \\ = 791.7 \text{ ohms.}$$

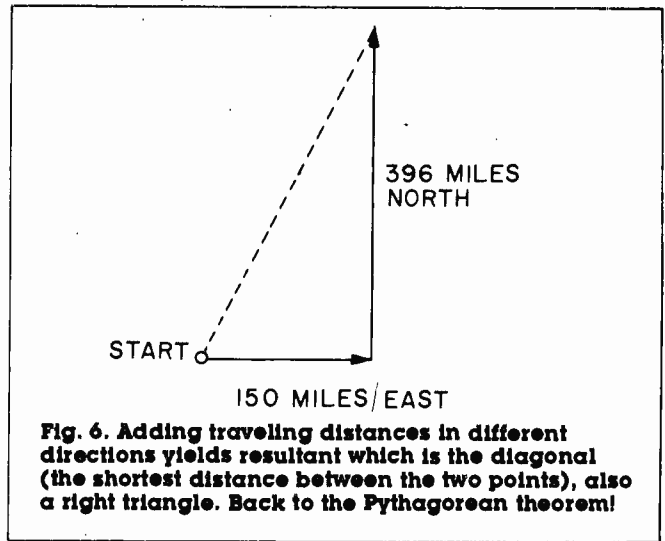

Fig. 6. Adding travelling distances in different directions yields resultant which is the diagonal (the shortest distance between the two points), also a right angle. Back to the Pythagorean theorem!

The new current becomes, ignoring, for the moment, the 6-ohm bulb:

$$I = E/X \\ = 100 \text{ volts}/791.7 \text{ ohms}, \\ = 0.125 \text{ ampere.}$$

which is about half the rated current of the bulb. Hence, it would be dim at this frequency. You can easily calculate that at 50 Hz, the X becomes 329.9 ohms and the current rises to the excessive value of .303 amperes; any further lowering of frequency could burn out the bulb!

Enter the Capacitor

Returning to the parts-supply bin, we now take a large, *oil-filled* (—Don't try this with an electrolytic!) capacitor, and, measuring it on a capacitance bridge, find that its true value is 6.8 uF. An ohmmeter placed across the capacitor's terminals registers an upward 'kick' of the needle as the ohmmeter's internal battery charges the capacitor, but the ohmmeter then settles down to indicate that, as far as *it* is concerned, the capacitor is—as it should be—an open circuit.

We now replace the 390-ohm resistor of Fig 1. with the 6.8 uF capacitor, as shown in Fig. 4.

Again set the oscillator to 60 Hz, and turn on the equipment. Since the capacitor is really an open

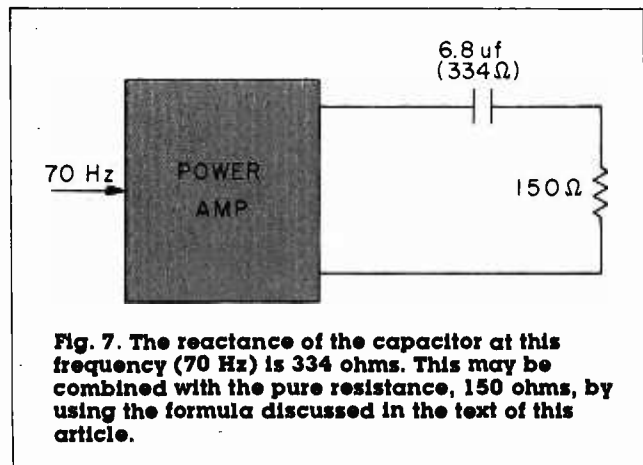

Fig. 7. The reactance of the capacitor at this frequency (70 Hz) is 334 ohms. This may be combined with the pure resistance, 150 ohms, by using the formula discussed in the text of this article.

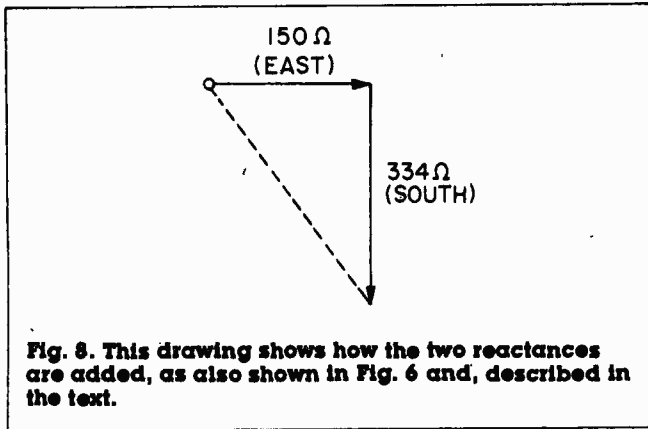

Fig. 8. This drawing shows how the two reactances are added, as also shown in Fig. 6 and, described in the text.

circuit—according to the ohmmeter—one might expect no current flow at all. We are surprised, then, when the light bulb blithely ignores our oil-filled open circuit, and proceeds to glow as serenely and confidently as it did for the inductor and resistor! When we drop the frequency to 30 Hz, the bulb goes dim—when we gingerly raise the frequency to 70 Hz, the bulb gets brighter. This is just the opposite of the inductive effect, where the bulb got dimmer for higher frequencies.

Capacitive Reactance

Its behavior in the face of changing frequency of that shown by inductive reactance. A capacitor's appearance resistance goes down as frequency goes up, and goes up as frequency goes down. This inverse relationship is seen in the expression for capacitive reactance, which is

$$X_c = \frac{1}{2\pi fC}$$

where X is capacitive reactance, and C is the capacity in farads, (not microfarads.)

Mathematically speaking, by placing f (frequency) in the denominator (bottom) of the fraction, we are saying that as f gets larger, the answer (X_c) gets smaller, which is exactly what we observed in the lab experiment above.

Just as in the inductive case, we can plug X_L right into the Ohm's law formula and have a way to calculate current or voltage for a capacitive circuit:

$$I = \frac{E}{X}$$

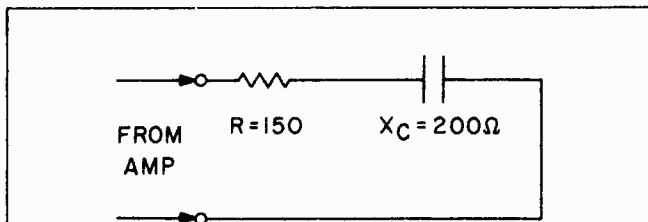

Fig. 9. Schematic showing reactance of capacitor. The two reactances add according to the formula, to yield a combined reactance (at the particular frequency used) of 250 ohms.

More Examples

As examples of how the above formulas can be used, let's calculate reactances and currents of our 6.8- μ F capacitor at various frequencies at 60 Hz,

$$\begin{aligned} X_c &= \frac{1}{2\pi fC} \\ &= \frac{1}{2\pi(60)(6.8 \times 10^{-6})} \\ &= 390.1 \text{ ohms} \end{aligned}$$

(Note that 6.8 microFarads must be expressed as 6.8×10^{-6} Farads, since the formula is always written for C in Farads. Alternately, you could write 6.8 microFarads as 0.000.006,8 Farads, but that's a little more awkward to handle.)

At 30 Hz, a lower frequency, the capacitive reactance increases:

$$\begin{aligned} X_c &= \frac{1}{2\pi(30)(6.8 \times 10^{-6})} \\ &= 780.2 \text{ ohms,} \end{aligned}$$

and at a higher frequency, say 70 Hz, the capacitive reactance becomes less:

$$\begin{aligned} X_c &= \frac{1}{2\pi(70)(6.8 \times 10^{-6})} \\ &= 334.4 \text{ ohms} \end{aligned}$$

The current, in any case, can be found by Ohm's law. At 70 Hz, the current is

$$\begin{aligned} I &= E/X, \\ &= 100 \text{ volts}/334.4 \text{ ohms,} \\ &= 0.299 \text{ ampere,} \end{aligned}$$

while at 30 Hz the current is:

$$\begin{aligned} E/X &= 100 \text{ volts}/780.2 \text{ ohms,} \\ &= 0.128 \text{ ampere.} \end{aligned}$$

So, in their way, both inductors and capacitors are obedient to Ohm's law. Their reactances— X_L and X_C , respectively—can replace the R in the familiar Ohm's law expression, $I = E/R$ enabling us to calculate current flow for AC circuits which include inductors or capacitors.

Adding Apples and Oranges

But, what if circuits which combine an inductor and a resistor? Or an inductor and a capacitor? Can we simply add the two 'ohms' together? Do resistance and reactance add like apples and apples?

Unfortunately, this is not the case. Consider, for example, the circuit of Fig. 5. Here, our 1.05-Henry inductor and a 150-ohm resistor are connected in series across the 100-volt, 60-Hz source. What is the current flow?

Obviously, we need an Ohm's-law-like expression—

something like: $I = E$, divided by the apparent "resistance" of R and L , combined.

We know from our previous work that a 1.05-Henry inductor has an X inductive reactance of about 396 ohms. We wish that we could simply add the 396 ohms of reactance to the 150 ohms of resistance to get 546 ohms—but reactance and resistance simply don't add that way. *Instead, they add at right angles!* And how, you ask, does one add at right angles?

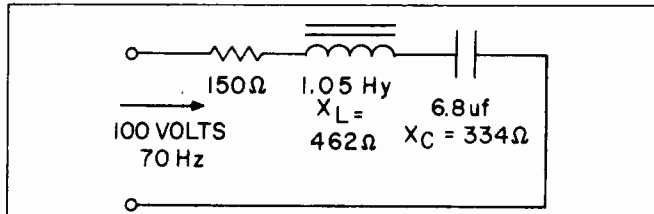

Fig. 10. Combining capacitive reactance and inductive reactance is also handled. Reactance of each at 70 Hz is computed, they are added together, and the difference is put into the formula with the pure resistance value.

A Journey at Right Angles.

To understand how resistance and reactance can add at right angles, consider another type of problem: If I traveled 150 miles due east, and then 396 miles north, how far am I from my starting point? See Fig. 6.

You obviously cannot get the answer to this problem by adding 396 to 150, because you're certainly not 546 miles from home. But notice that the figure is a right triangle—a shape which that old Greek, Pythagoras, solved long ago. He said that if your *square* 396, add the squares, and then take the square root, you will get the length (L) of the longest side:

$$L = (150 \times 150) + (396 \times 396),$$

$$L = 179,316$$

$$L = 432.3 \text{ miles}$$

This, then is a way of adding two quantities that act at right angles to each other. Since inductive reactance is a kind of "north-bound resistance" operating at right

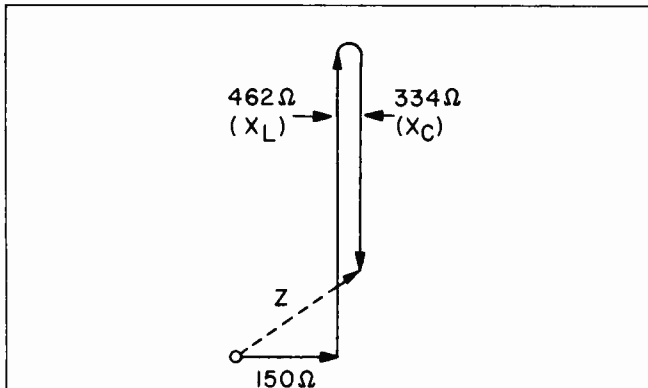

Fig. 11. The relative "directions" of capacitive and inductive reactances along with that of the pure resistance. Z (the diagonal) is the resultant of the 150-ohms resistance plus the difference between the two reactances.

angles to the "east bound resistance" of an ordinary resistor, we combine the two by adding at right angles, just as the two right-angle distances were added in the above mileage problem. The effective resistance of the 396-ohm reactance and the 150-ohm resistor is therefore:

$$(150 \times 150) + (396 \times 396),$$

which is equal to 432.4 ohms.

What do we call this combination? It's obviously neither resistance nor reactance, but a combination of both. Since it represents a *general* way that a circuit can impede the flow of electrons, it is called *impedance*, and is represented by the symbol Z . The general formula for impedance is, therefore:

$$Z = R^2 + X^2$$

Another Candidate for Ohm's Law

Impedance is measured in *ohms*, just as are reactance and resistance. If you know the impedance and voltage in a circuit, we can find the current I by plugging Z into the familiar Ohm's Law expression:

$$I = E/Z,$$

$$= E/R^2 + X^2.$$

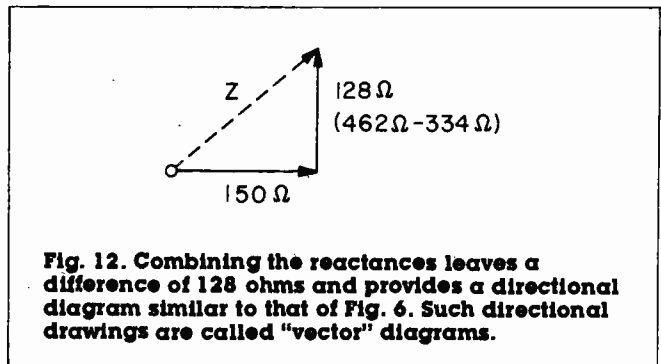

Fig. 12. Combining the reactances leaves a difference of 128 ohms and provides a directional diagram similar to that of Fig. 6. Such directional drawings are called "vector" diagrams.

Using this expression we can calculate the current in the example of Fig. 5—

$$\begin{aligned} I &= E/Z, \\ &= 10 \text{ volts}/423.4 \text{ ohms}, \\ &= 0.326 \text{ ampere.} \end{aligned}$$

Southbound Capacitors

The knowledge that inductive reactance adds at right angles to resistance leads immediately to the question. "What about *capacitive* reactance? Does it also act as a 'northbound' resistance?"

As you might expect, two circuit elements as different as inductance and capacitance could never agree on the 'direction' of their reactances. If inductive reactance is 'northbound', the capacitor obstinately declares that *its* reactance is 'southbound', acting in direct opposition to the inductive direction, as shown in Figs. 7 and 8.

However, this makes no difference in the equation for impedance, which is still given by

$$Z = R^2 + X^2,$$

(Continued on page 95)

AM STEREO, THE NEW KID ON THE BLOCK

By Jim Keightley Chief Engineer, KAPA

Is the *new* mode of AM broadcasting really *new*? Well, consider this! Clear back in the fifties, Leonard Kahn went on the air with an AM stereo system on a test basis. This was well before FM radio was on its way to its Present domination of stereo broadcasting. However, little interest was shown in the system due to the fact that AM dominated the industry and broadcasters saw no need for AM to change or improve its techniques.

On the other hand, FM, with it's need to "get out of the cellar" and become a viable force in the broadcast market, needed to attract new listeners and was ready to accept stereo. There soon was developed the system that we hear on the air today, using a multiplexing, technique.

The FM channel is comparatively wide with room to place the necessary stereo sub-carrier and still have space for wide audio-frequency range. AM on the other hand, does not enjoy the wide channel spacing and this introduces problems that have led to some interesting approaches to getting the left and right channels for stereo on the air while retaining the ability of existing envelope detectors to decode the combined or monoural signal.

How It's Done

Let's briefly examine two of these systems. Motorola, in their C-Quam system uses the AM mono sum, that is the *Left plus Right* (L+R) sum, to modulate the transmitter in the normal way, creating the on-the-air

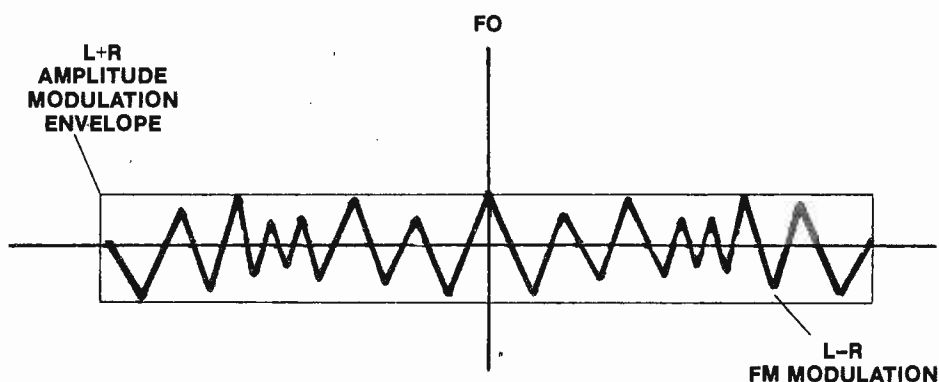

Fig. 1. The Motorola C-Quam AM stereo system used normally used AM to transmit the L+R audio program and FM modulation of the carrier frequency to transmit L-R information.

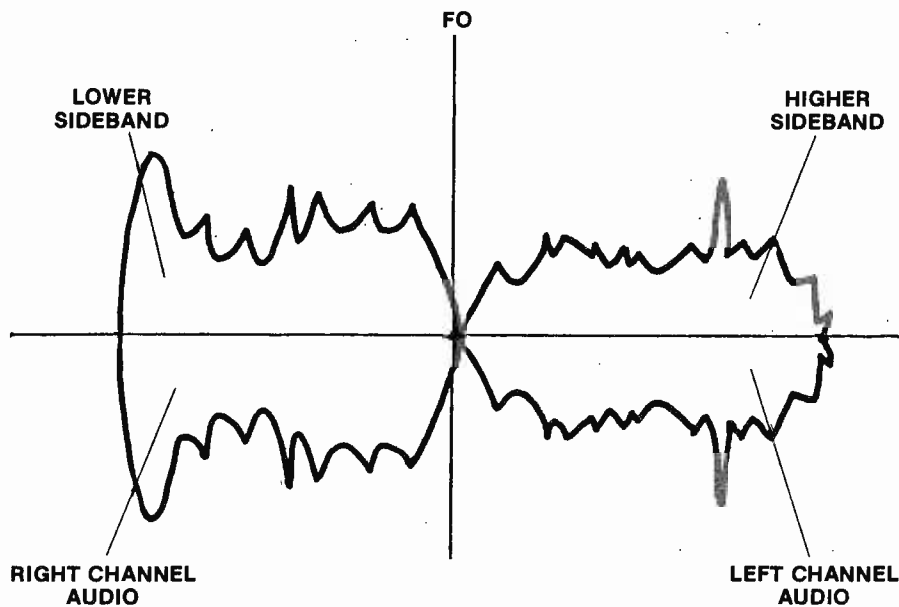

Fig. 2 . The Kahn-Hazeltine system amplitude modulates the lower sideband with the right channel audio and the upper sideband with the left channel audio. Conventional receivers mix both sidebands resulting in L+R (mono) audio.

sound and signal that we are accustomed to hearing, and that the existing receivers are capable of decoding. See Fig. 1 The *Left minus Right* (L-R) Portion of the signal is then used to frequency modulate the carrier. The composite radiated signal is then a combination of AM and FM.

When this combination is carefully and properly balanced, the mono signal sounds at least as good as the pre-stereo transmission. In addition receivers with the proper decoding circuits can "hear" the signal in stereo.

In Practice, this system has proven to have some faults. A phenomenon known as *platform motion* occurred. This cause a very undesirable sensation that as one listens, the platform that the musicians are on is shifting from side to side. When I experience this phenomena, I feel that I am falling to one side or the other. Perhaps this is akin to vertigo. There are several causes of platform motion, but for this brief discussion, suffice it to say that it is phase related.

In the Kahn-Hazeltine system, a somewhat different approach is used. Mr. Kahn decided to put the left channel on the upper sideband and the right channel on the lower sideband. See Fig 2.

The envelope detectors that are in common use today hear the two sidebands as the composite or monoural signal. By using the proper circuitry, the two independent sidebands are heard as the two channels of stereo. Since the sidebands are independent of each other, this system is often referred to as the *independent sideband system*. Two of the advantages of this system are that there is no platform motion and the stereo effect is present even at extreme broadcast range.

They Are There!

There are presently well over 400 AM stations in the U.S. and Canada that are transmitting in AM stereo using one of the systems that we have discussed here or one the other systems that had been produced earlier, but are no longer in competition. Some that have dropped out of the running are Magnavox, Belar and Harris. All of these used some form of the AM/FM method of stereo transmission.

At this time, the two remaining contenders for the AM stereo market are Motorola and Kahn. A recent poll of broadcast engineers revealed that they favor the Kahn system by a margin of 12 to 1, a most interesting finding since Motorola has over 200 system in service while Kahn has about 100. Perhaps the station owners are not listening to their engineering staff.

At this writing, receiver manufacturers have been somewhat slow to place receivers on the market that have AM stereo capability. Perhaps this can be blamed partly on the unavailability of an IC chip that will decode all of the system. However, Kahn Communications recently introduced a chip that will decode all of the system in present use. The manufacturing rights were given to Sony and the chip will be available to all interested manufacturers. The cost is comparable to the one presently offered by Motorola so we should soon see receivers on the market that can hear all of the AM stereo systems.

What system will emerge as the dominant one? I surely can not say. However, it seems that with advent of multi-mode receivers (five manufacturers are expected to be in production soon) the listener will have a strong voice in the matter and will vote with the tuning knob for the system that sounds best to him. ■



OSCILLATING AMPLIFIERS

By Rodger D. Connith

As any slightly cynical experimenter can tell you, if you want an oscillator, build an amplifier—it's sure to oscillate. Conversely, if you want an amplifier, (this same cynic will tell you), build an oscillator—it's sure to fail to oscillate, and you can then use it as an amplifier! This is well known as a corollary to Murphy's famous law, "If anything *can* go wrong—it *will*!"

Our informed cynic must have had long and unhappy experience with negative-feedback amplifiers, which are known to have at least two outstanding characteristics:

1. They function beautifully if carefully designed and built.
2. Otherwise, they oscillate!

Why do they oscillate? Or, more basically, how does a feedback amplifier differ from an oscillator?

The fundamental block diagrams of an oscillator and an amplifier with feedback bear a strong resemblance

to each other, as you can see from Fig. 1. From a block diagram viewpoint, both diagrams are very similar. Both contain some type of amplifying device, and both have part of their output signal fed back to their input. There are only two major differences between them:

1. The amplifier with feedback contains an *inverting* amplifier; the oscillator contains a *non-inverting* amplifier.

2. The oscillator doesn't have an input.

The circuit action obtained from these two circuits is entirely different. In the amplifier with feedback, the output waveform is upside down with respect to the input, so when it is fed back to the amplifier input, it cancels a portion of the input waveform. The output is less than it would be without feedback. See Fig. 2.

The feedback signals from inverting amplifiers are not "in phase" with the input signal and subtract (or reduce) the input signal level to the amplifier. When a feedback signal does this, it is called *negative feedback*.

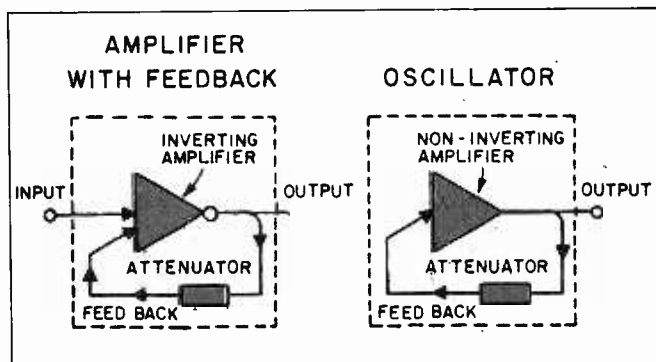

Fig. 1. Two block diagrams compare an inverting amplifier (A) to an oscillator (B).

So Why Negative Feedback?

Of course, if you merely want the biggest possible gain for your money, negative feedback's not your game. However, negative feedback offers other advantages, which can be summed up by saying that the amplifier's output, though smaller, is always nearly constant for the same input signal. For example, if the amplifier weakens, with age, and the output tries to drop, there is less signal to be fed back; hence there is less cancellation, and the output is restored almost to its former level. Similarly, if you feed a high-frequency signal through the amplifier—so high in frequency that the amplifier can barely amplify it—the resultant drop in output reduces the fed-back voltage, produces

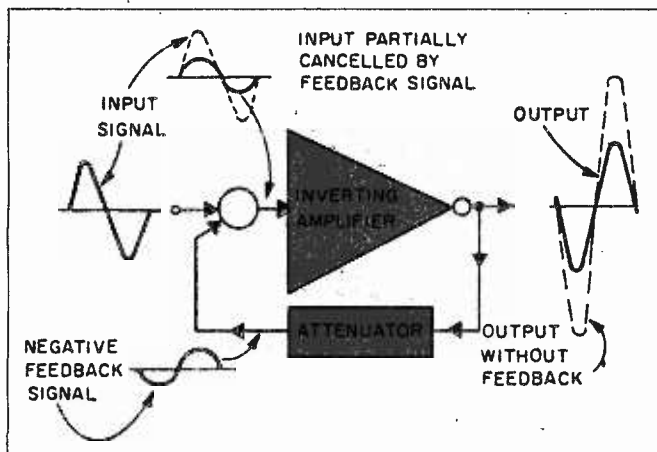

Fig. 2. Signal flow diagram illustrates how feedback in an inverting amplifier circuit reduces overall gain.

almost no cancelling feedback signal, and keeps the output nearly the same as it was at lower frequencies. Moreover, any clipping or other distortion of the waveform inside the amplifier produces an output waveform which does not match the input; hence the non-matching part is not cancelled, and the distortion is removed, or at least greatly reduced. Without this action, hi-fi amplifiers would not exist.

So the loss in output you obtain from negative feedback repays you by providing less distortion, better long-term stability, and better frequency response—that is, the best and most uniform output in response to *all* input frequencies.

On the Flip Side

The oscillator, on the other hand, is not supposed to give the best output from all input frequencies, but is instead made to give an output at a *single* frequency—with no input at all. It's not surprising that the opposite type of internal amplifier (non-inverting) is used to obtain this opposite result. See Fig. 3.

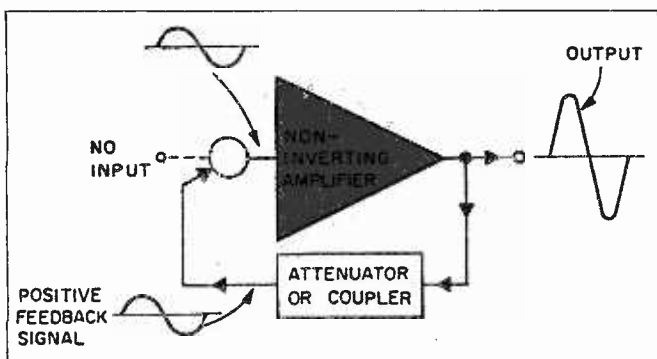

Fig. 3. Signal flow diagrams shows how feedback signal from a non-inverting amplifier provides the positive feedback to produce an output signal larger than it would otherwise be without feedback.

In the oscillator, any output at all (probably the result of some random noise in the internal amplifying device) is fed back, non-inverted, to the input, where it does not cancel but instead serves as the signal at the input. This feedback signal causes an even larger output, which results in an ever larger signal fed back, further reinforcing the input signal, and so on.

You guessed it—this type of feedback signal is

commonly referred to as *positive feedback*. In theory, the output waveform should continue to get larger forever. In practice, the amplifier is limited in the maximum size of the signal it can deliver, so the output waveform stops growing in this amplitude. As it stops to grow, so does the positive feedback signal. Now the signal reduces rapidly and the positive feedback signal lends a hand until the signal can get no lower. This is the beginning of the first cycle of many to follow.

All well and good, you say, but if the major difference between feedback amplifiers and oscillators is the inverting or non-inverting nature of their internal amplifiers, why does an amplifier sometimes oscillate? What turns an inverting amplifier into a non-inverting one?

To answer this question, first observe that an inverting amplifier, in passing a sine-wave signal, *effectively* shifts the signals phase by 180° as shown in Fig. 4. We say *effectively*, because it doesn't really shift the timing by delaying the signal (which is what a real phase-shifter does) but, by turning the signal upside

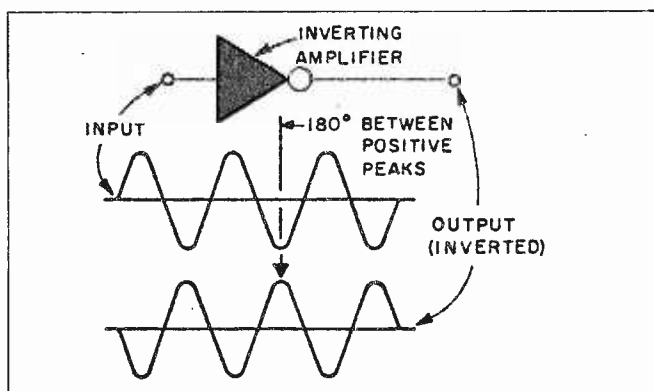

Fig. 4. The apparent phase shift of the output signal from the input signal is 180 degrees.

down, the amplifier makes it look like a signal which has been delayed (phase-shifted) by 180° .

A real phase-shifter, on the other hand, is normally nothing but a fistful of judiciously connected resistors and capacitors (and sometimes inductors) which can be designed to give a 180° phase shift at a *single frequency*, such as 1,000Hz, for example. In contrast to an inverting amplifier, it provides this phase shift by actually delaying the signal. See Fig. 5.

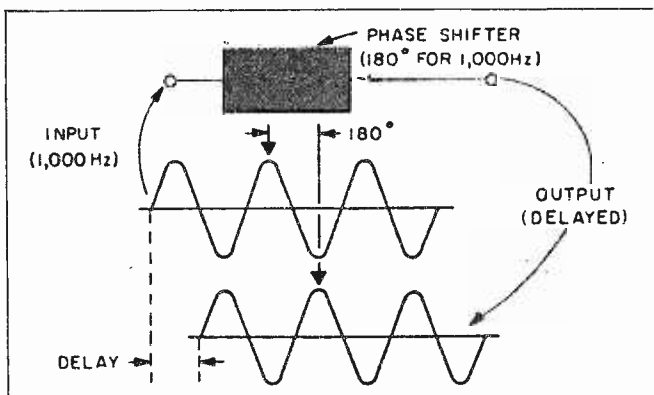

Fig. 5. The passive phase-shift circuit actually delays the output signal by a time interval measured in degrees by that portion of a sine wave so delayed. This effect appears to the apparent delay of an inverting amplifier.

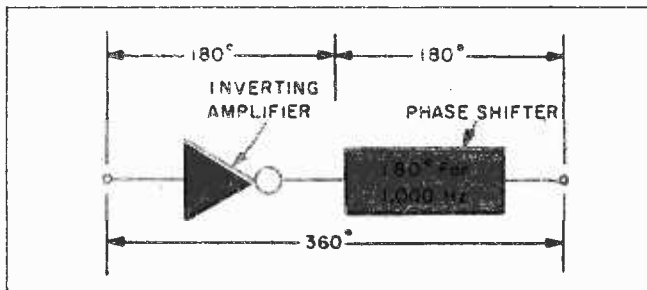

Fig. 6. Combining an inverting amplifier and 180-degree phase-shift circuit results in a 360-degree phase shift at 1000 Hertz only, which results in a non-inverting amplifier circuit.

How can one "inadvertently" make a phase-shifter? It's easier than you might think. The circuit shown in Fig. 8A will provide 60° phase shift, at 1,000 Hz. Three such networks connected in a "ladder" (see Fig. 8B) will provide $3 \times 60^\circ = 180^\circ$ of phase shift. (But not at 1,000 Hz. Because of the way the networks load each other, the 180° shift occurs at 707 Hz. However, if an amplifier were located between each network, then the amplifier will oscillate at 1,000 Hz.) This network, if dropped into a normal feedback amplifier circuit, will convert it to an oscillator.

Phase-Shift Oscillator

This circuit (Fig. 9) is known as a *phase-shift oscillator* and is widely used in electronics. When you

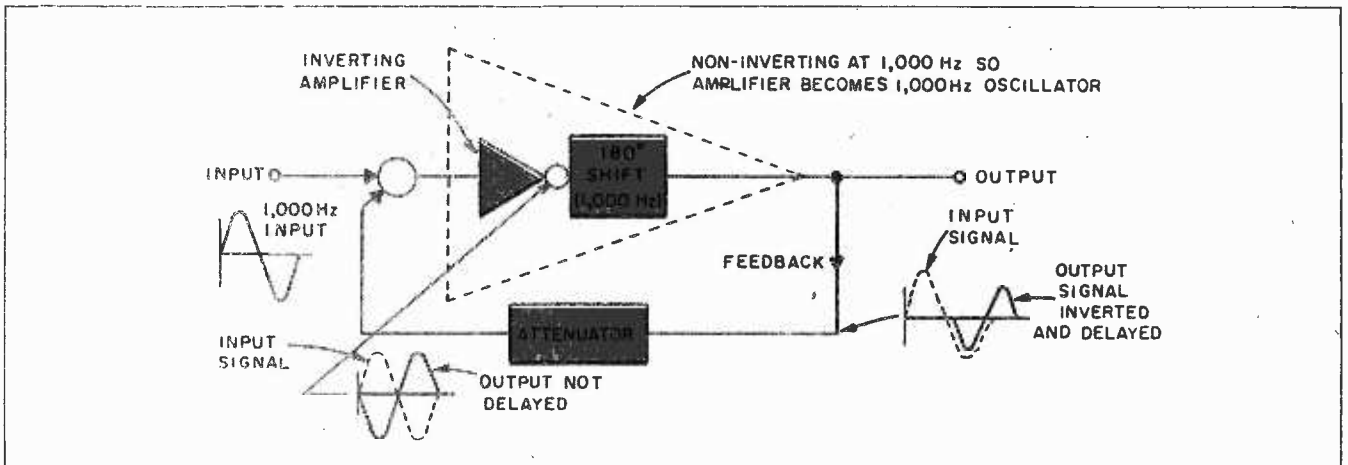

Fig. 7. Since the 180-degree phase shift is frequency selective, this non-inverting amplifier will oscillate at 1000 Hertz.

What happens if we combine an inverting amplifier and a 180° phase-shifter? Take a look at Fig. 6.

This combination will shift the phase of a given frequency by a total of 360° (an entire cycle) so the output is identical to the input. In effect, this combination (at 1,000Hz) will behave the same as a non-inverting amplifier. See Fig. 6.

Therefore, if we build a feedback amplifier which contains the normal inverting amplifier but also (inadvertently) contains a 180° phase-shift network, the resultant circuit will oscillate at the particular frequency, (1,000Hz in the figure) for which the phase-shifter provides 180° phase shift. See Fig. 7.

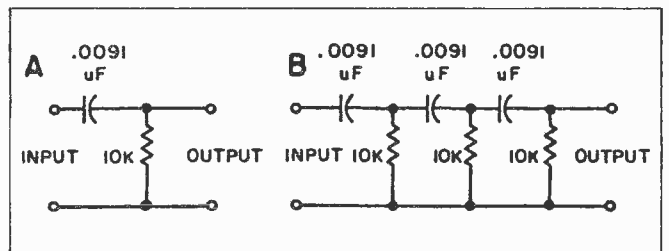

Fig. 8. In this diagram, a simple network (A) offers 60-degrees of phase shift at 1000 Hertz. Ladder three such circuits in series and the total phase shift at 1000 Hertz will be 180 degrees.

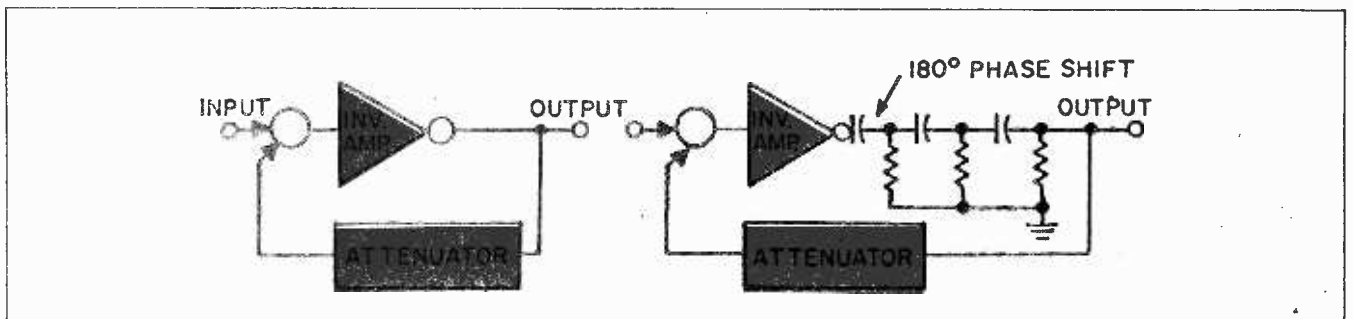

Fig. 9. Two inverter amplifiers are shown here with one having a 180-degree phase-shift network added to induce positive feedback. The RC elements limit this oscillation to a fixed frequency.

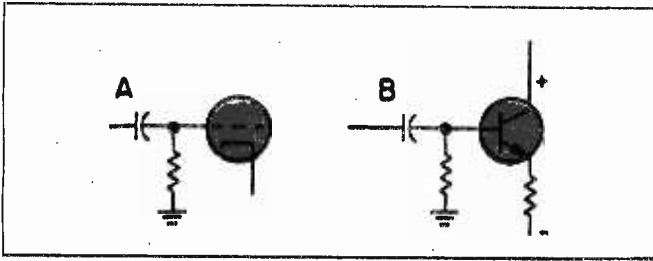

Fig. 10. External parts in this amplifier circuit have the same effect as the phase-shifter in Fig. 8A. However, values for the resistance and capacitance are selected to produce almost no phase-shift within the amplifiers normal frequency bandpass.

set out to build a phase-shift oscillator, you *deliberately* insert a phase-shifter to make the circuit oscillate. How could one ever *inadvertently* place such a circuit in a feedback amplifier, thereby producing unwanted oscillations?

Phase-shift circuits can "hide" within an amplifier, posing as other circuits. For example, vacuum-type amplifiers often have grid circuits arranged as shown in Fig. 10A. Does that resistor/capacitor circuit look familiar? In form, it's just like the phase-shift circuit above. And transistor amplifier circuits often take the form shown in Fig. 10B.

Again, the coupling/biasing network looks just like the basic phase-shifter network. At some frequency, this network will provide 60° of phase shift. If we use three such identical networks in a three-stage amplifier we have a 180° phase-shift network "buried" inside the amplifier, masquerading as three normal coupling networks. If this three-stage amplifier is used as part of a feedback amplifier arrangement, the amplifier will

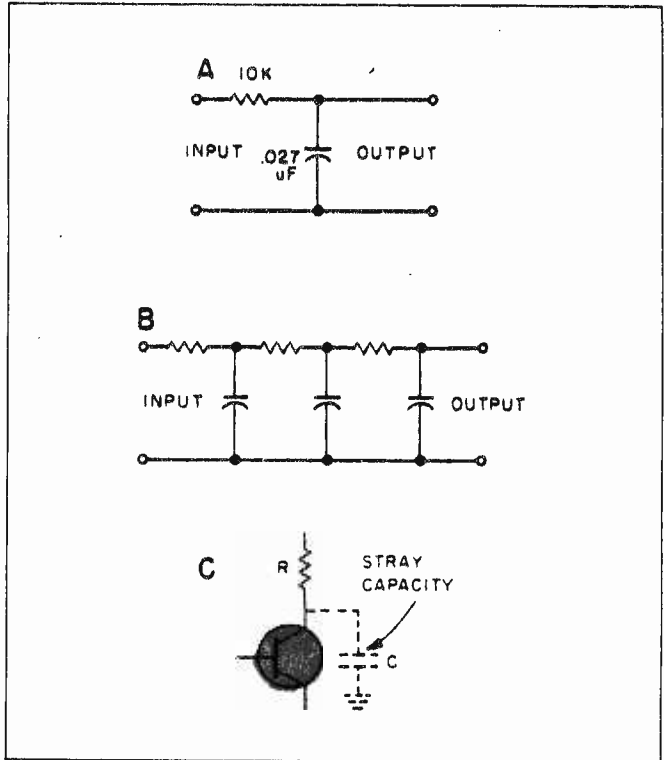

Fig. 11. Don't get confused with the circuit elements shown in (A) with those shown in Fig. 8A. The reversal of parts converts the basic circuit from a coupler to a filter with the attending phase shift. Three series-connected filters have the same effect (B) by providing 180-degree phase shift. Hidden capacitance (C) internal to the circuit element and in the external wiring will provide some phase shift of the output signal in this amplifier.

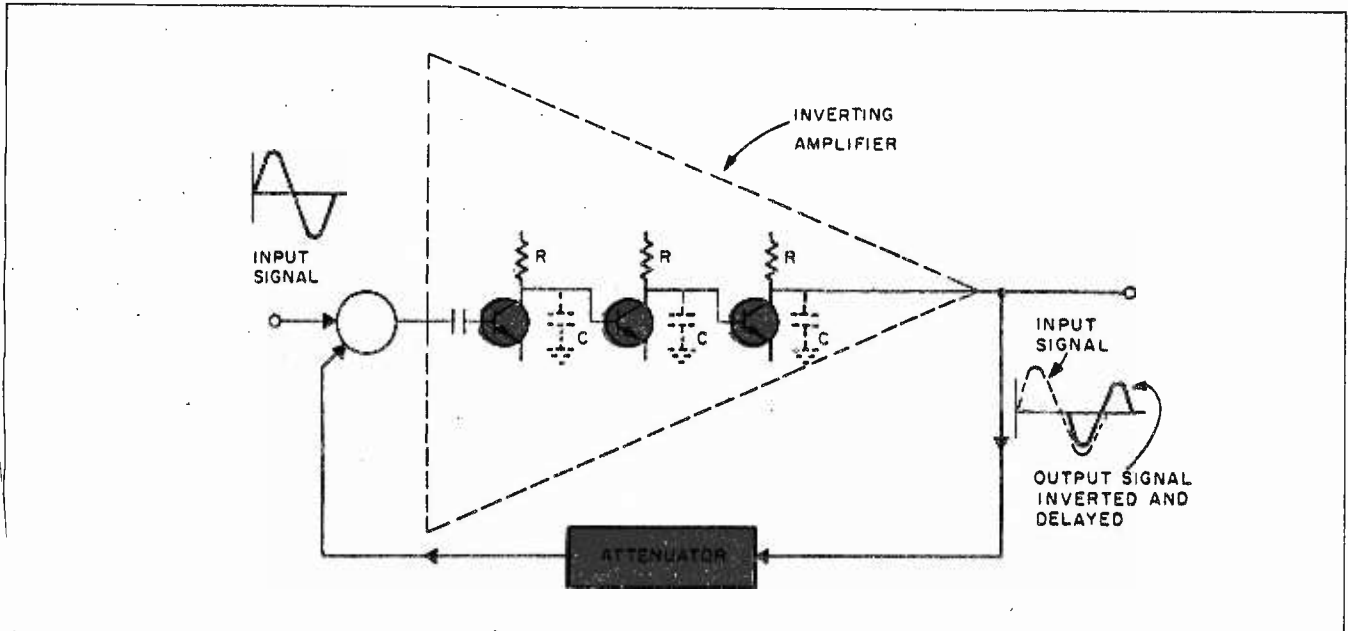

Fig. 12. An inverting amplifier may oscillate do to stray capacitance in these external circuit amplifiers providing a 180-degree phase shift at some very high frequency. Output signal is within frequency bandpass of the amplifier before phase shift causes oscillation (positive feedback).

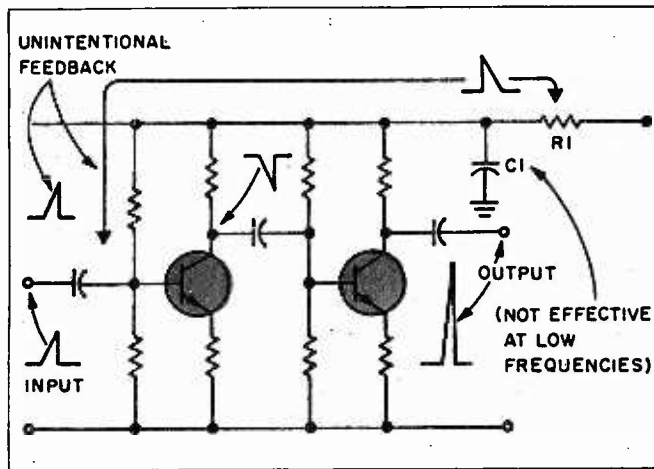

Fig. 13. Low frequency feedback occurs because the capacitor C1 is not effective at these low frequencies. Thus, any portion of the output signal that will cause a ripple in the power supply will serve as a positive feedback.

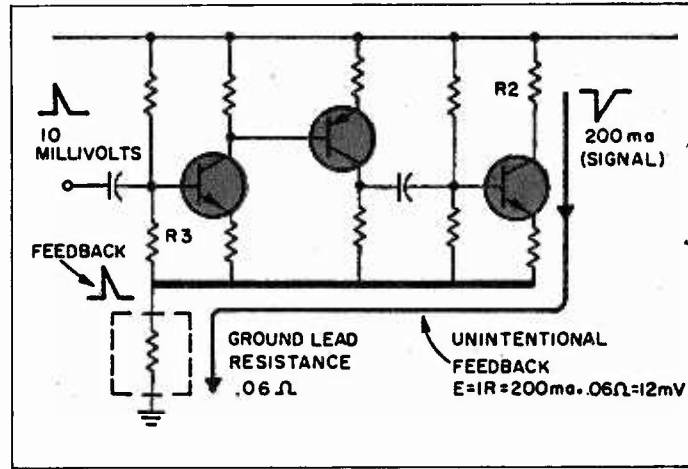

Fig. 14. A ground bus has a finite resistance, and, when high-current output signal mix with low-level signals in the same bus, positive feedback may result with the attending possibility of oscillation.

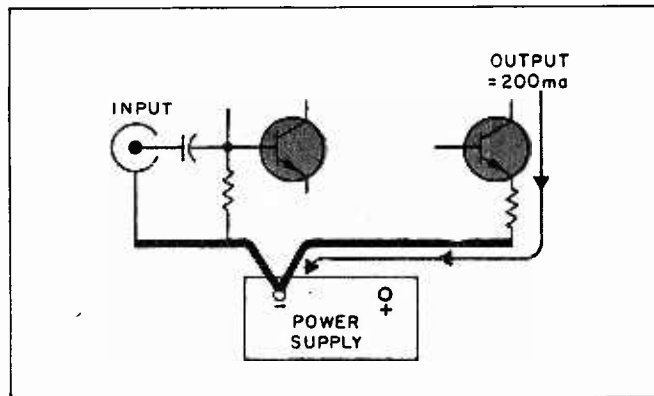

Fig. 15. Divide and conquer—separate input connections from output connections to different buses, and a good deal of the unwanted signal mixing will not occur. The resistance of the power supply must be very low otherwise all that is gained using this construction technique will be lost.

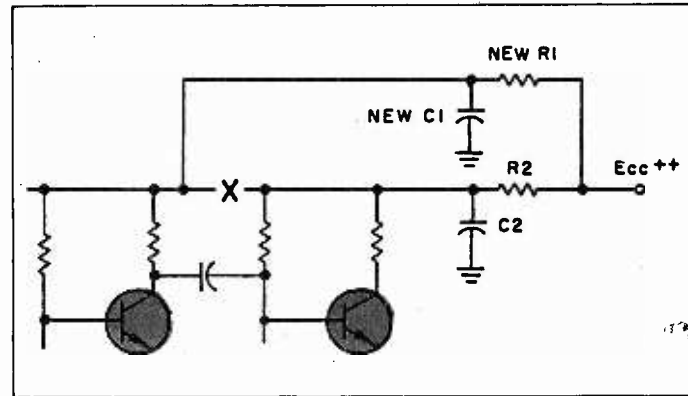

Fig. 16. A good idea is to split up the voltage distribution to many circuit points by two or more power supply decoupling networks. Compare this diagram to Fig. 13.

oscillate at some frequency, and be quite useless for the purpose for which it was intended.

More Trouble

This is not the only way an amplifier can get into trouble. There are other types of phase-shifters that can creep into amplifiers, unrecognized, and drive the unwary experimenter up the nearest wall. This circuit (shown in Fig. 11A) can also produce a phase-shift of 60° at 1,000Hz. Three of them, can produce the 180° phase-shift required for oscillation. See Fig. 11B. This particular network can invade amplifiers in an even more insidious fashion. The "masquerading" part of the circuit is shown heavy in Fig. 11C. The dotted capacitor doesn't appear physically in the circuit, because it is the so-called "stray capacity" associated with wires, sockets, terminals, etc.

Three of these circuits hiding in an amplifier, can produce an unwanted oscillation. See Fig. 12. Since the stray capacities are so small, this "oscillator" will oscillate at a very high frequency; often so high that it is undetected as an oscillation. However, such oscillation

can make an amplifier behave erratically; sometimes distorting, sometimes not; sometimes overheating, sometimes not. Fig. 7 and Fig. 12 have a lot in common.

Are feedback amplifiers the only culprits in this oscillating-amplifier business? Absolutely not! Often, so-called "straight" amplifiers—with no *intentional* feedback—will gaily oscillate away. But watch that word *intentional*. Close inspection of these misbehaving circuits usually uncovers an *unintentional* feedback path hiding within the amplifier.

Consider the innocent-looking circuit in Fig. 13. This is an ordinary two-stage amplifier, obviously assigned the task of converting a small, positive-going signal into a large, positive-going signal. To help it along, the designer has even provided a decoupling network, R1 and C1. At high frequencies, C1 acts like a short circuit, effectively isolating (decoupling) the amplifier's power bus, Ecc +, from the main power bus, Ecc ++. But at low frequencies, the capacitor acts like an open circuit—it just isn't there! A small part of the output voltage now appears across R1, and is coupled through the

(Continued on page 96)

SPUN DISHES PULL IN SATELLITES

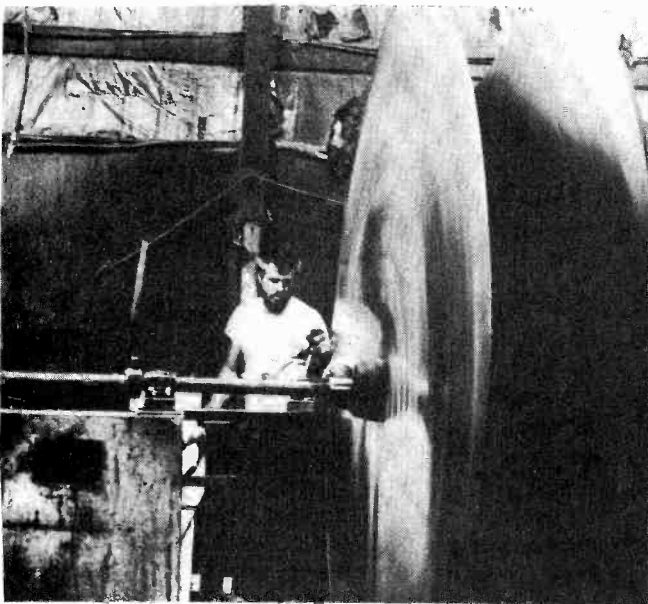
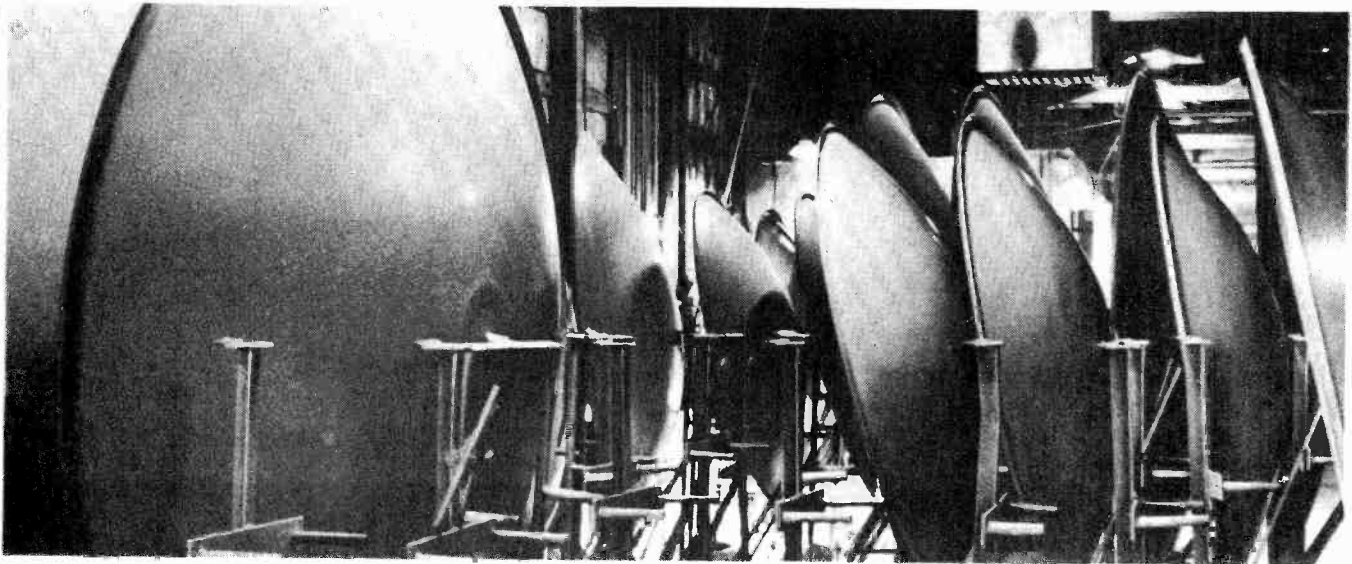

The fabrication of an aluminum satellite dish antenna begins with the large diameter disk being secured to a mold where it will be spin-formed. The wheel spins at the rate of 250 rpm, taking only a little more than three minutes to form the completed antenna.

The satellite TV dish antenna, described by some as having the greatest potential for changing the lives of Americans since the automobile, is experiencing phenomenal growth, with some industry spokesmen predicting the production of 500,000 units this year alone.

Franklin Weeks, president of DH Satellite, a division of Design Homes, Inc., Prairie Du Chien, predicts his firm will probably produce about 100,000 of these. (That's right, a one and five zeros!) There are already in excess of one million of these satellite dish antennas now in use in the country, he said.

Although capable of manufacturing both steel and aluminum dishes, Mr. Weeks said he has just about switched to all aluminum because of several factors, including aluminum's light weight, its accuracy and its efficiency rate of up to 73 percent.

Although Design Homes, which has been producing modular and mobile homes since 1966, has only been in the antennas business for the past four years, Mr. Weeks says the growth has been steady during this time. He noted he originally began making the dishes at a rate of about 400 a month. Now, he says in his peak month of April of 1985, his firm produced more than 10,000 nearly all of which were manufactured by the spun aluminum process.

COMMUNICATIONS WORLD

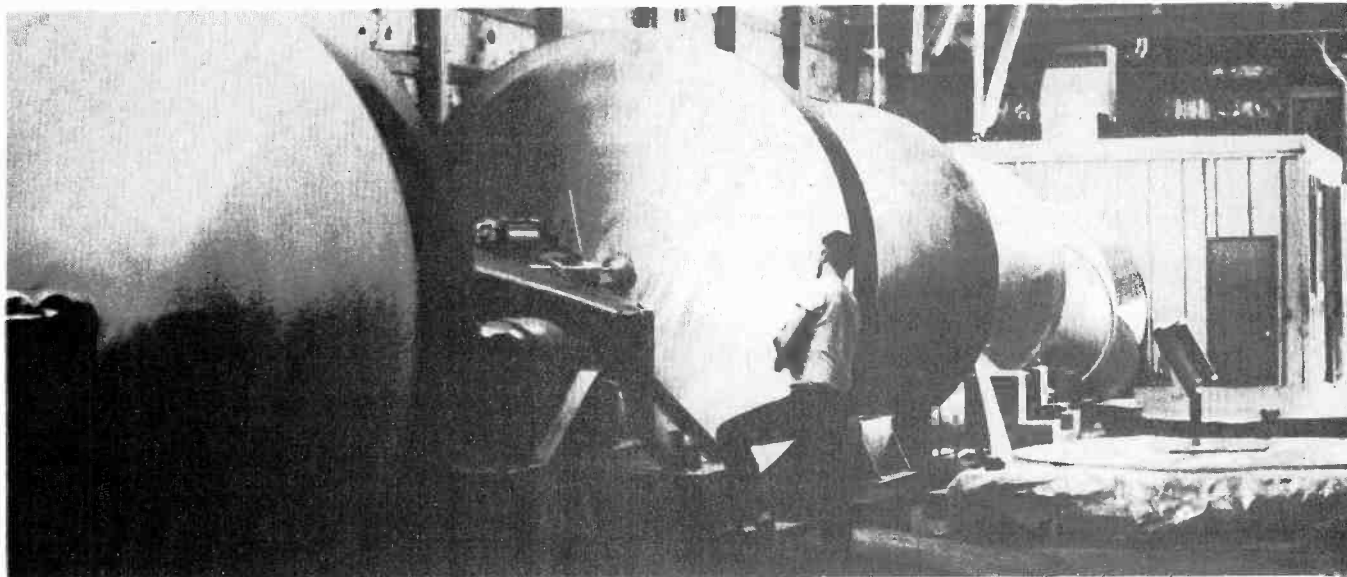

An employee of DH Satellite inspects one of the molds which the firm spins to produce aluminum satellite antenna. Reynolds Metals Company, the major supplier of the aluminum, ships circle blanks to the Wisconsin firm cut to the proper diameter. The blanks can be seen stacked to the right of the huge molds.



Franklin Weeks, president of DH Satellite, a division of Design Homes, Inc., Prairie Du Chien, Wisc., displays some of the aluminum satellite dish antennas his firm manufactures.

He said that to enter the business he had to design his own machines. His engineering department builds the molds, one of each size dish.

Dish Blanks. Reynolds Metals Company, his major supplier of aluminum sheet, ships .125 and .090 gauge sheet which has been pre-cut to the appropriate size circles in sizes ranging from 108 in., 96 in., 72 in. and 60 in. diameter. DH Satellite then spins them to the proper shape, they are cleaned, primed, painted and shipped to the firm's distributors which cover all 48 contiguous states. The plant is capable of producing 1,500 dishes per day. A special tool held to the surface of the spinning aluminum panel determines the shape of the dish on the automatic microprocessor-controlled spinning machine. The forming wheel spins at the rate of 250 rpm, meaning that it takes only three minutes, 14 seconds to produce one large nine-foot dish. Mr. Weeks notes that the dishes are painted to prevent damage to the electronics due to the reflected heat buildup.

In addition to the nine, eight, six and five-foot dishes, his firm also makes a steel-mesh model. However, 80 per cent of his units are aluminum. Reynolds, he noted, is the only company that can make the nine-foot circle. It is estimated that Reynolds has a 35 percent market share of the aluminum used in the manufacture of satellite dishes.

Mr. Weeks also has predicted tremendous growth. He reported that more than 23 million TV sets were sold last year. With the dish, a set can now get between 125 and 130 TV stations. With the number of satellites in orbit growing each year along with new programs being added, the consumer's attraction to satellite dishes will likely continue.

As for the future, he says his firm now is coming out with a folding dish antenna specifically designed for recreational vehicles. He said it will be a six foot, six-inch unit for installation next to the vehicle.

BEST-BUY PERSONAL WORD PROCESSOR

Inexpensive System Is Easy To Learn,
Includes a Spell-Correcting Typewriter.

By Charles Graham

If you've been looking at personal microcomputers with the idea of getting one to use for Word Processing (super typing), but you've been put off by the prices, at least \$1200, including a low-cost dot-matrix printer, look no further. Smith-Corona, world's biggest makers of electric typewriters for home and office use, has beaten everyone else to the market with a low-cost (\$800 for the cheapest model) complete word-processing system, including a *letter quality* typewriter-printer.

The typewriter-printer, depending on which model you choose, costs from \$300 up to \$600. The WP system itself, which is added to the electronic typewriter, costs only \$495.

In early November a full page advertisement appeared in New York papers showing a typewriter and a monitor screen and it said, "Get this low-cost Personal Word Processor for your home or office for only \$750. Regular price, \$999; special sale price until Thanksgiving, only \$750." The advertisement was placed by Macy's the world's largest department store, which most New Yorkers trust and buy from several times a year.

All Sold Out

I called the store up later in the week and asked about the ad. I was told they were all sold out of the SCM Personal Word Processor (PWP) but would get more within a couple of weeks. I put in my order, and this report tells about my experience with the easiest-to-learn, lowest-cost word processor yet to be offered on the market.

One reason the PWP is so low-priced is that it's a dedicated word processor. It can't do anything else. All it can do is type letters, edit them, store them, etc. You can't use it as a calculator; you can't play games on it or do spread-sheet analysis or forecasts. In fact, you can't do anything with it except *type* stuff, *edit* or *store* it, and *print* it out. Another reason is that SCM makes so



Complete SCM word processor system has four parts. They are, left, 12-inch monitor atop CPU (Central Processing Unit) right, combination typewriter/printer, and small control unit. List-price about \$1000, however, can be purchased for as low as \$800.

many electronic typewriters that it can supply a typewriter printer specially designed to work with the PWP.

Super-easy to Learn

Because it's a dedicated word processor, there are only a few things you have to learn to get it running and processing words. It's unlike all other previous word processing systems, even my own Digital Equipment DECmate II dedicated WP system, which is much easier to learn and to operate than WP programs used with regular personal computers.

Smith-Corona's PWP uses any of many SCM electronic typewriters as its printer. Actually, learning to use the PWP was easier than learning to use the typewriter/printer itself. That's because the typewriter is a very sophisticated one, but the WP itself, apart from the typewriter, is very simple.

KOMPUTER KORNER

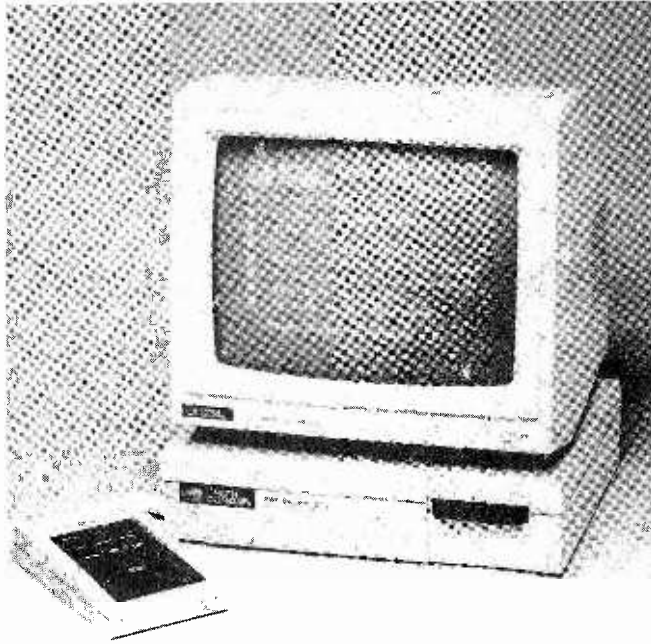

PWP Personal Word Processor by SCM lists for \$500, can be used with a large number of SCM electric typewriters costing from \$700 to under \$300. Shown here is 12-inch monitor atop Central Processing Unit, with small Control Unit at left.

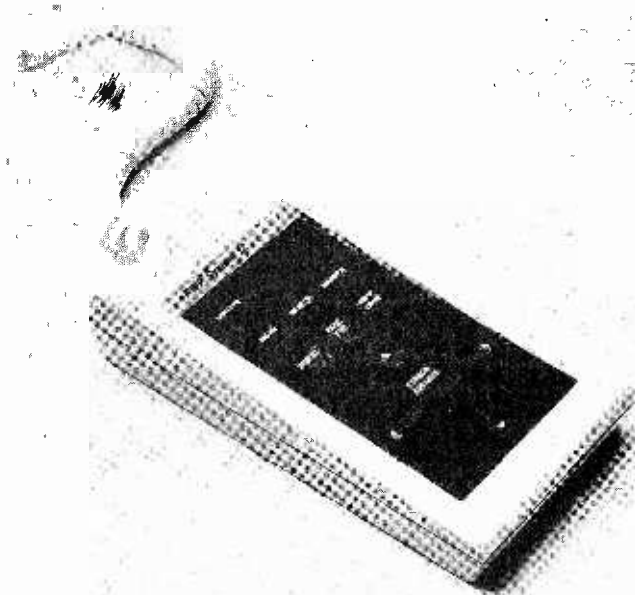

This small control unit runs all the word-processing functions of SCM's PWP (Personal Word Processor). It's set on desk beside a typewriter/printer.

Sophisticated Typewriter

Without the WP system, the typewriter can correct, alter, copy or delete a letter, a word, a complete line, or even a paragraph very quickly. It does this with a little white-out correction ribbon (mounted near the typing wheel, just below the printing ribbon), and its electronic memory. Most office typewriters today, and many home machines too, have this type-it-out correction feature. *Electric* typewriters (machines without an electronic memory) require a three-keystroke sequence to correct a wrong letter. The SCM does it with just one keystroke because it's *electronic*, and has a memory.

It also has many more sophisticated typing features, including (as an option, at extra cost) a spelling-check program. It's called the Spell-Right checker. This automatically checks the spelling of 35,000 words and if you've typed in a word incorrectly (or one that isn't on that 35,000-word list!) the machine makes a "beep" warning sound to alert you that you've made a mistake. An upgraded version of the Spell-Right allows you to add up to 300 specialized words of your own choosing, such as unusual names, or technical terms not included in the basic program.

Another feature allows wiping out (deleting) an entire word with just one keystroke. You just move the cursor (pointer) to any letter in the desired word, then tap the "Worderaser" key. Voila, the whole word disappears. Or you can delete a sentence (or a whole paragraph) with just two (or three) keys. Remember, we're just talking about the *typewriter* here, not the WP system.

There are many other editing features on the typewriter, but they'll appeal mostly to experienced typists. I will therefore discuss just the PWP system from here on.

It's a Simple System

In addition to the electronic typewriter/printer, the PWP includes a 12-inch monitor screen (green, for easier viewing for long periods of time) a small system unit which sits under the monitor, and a small keypad (about the size of a paperback book) which controls eight special WP functions not on the typewriter keyboard.

The keypad has four cursor-direction keys (UP, DOWN, LEFT, RIGHT) to make the marker go wherever you want it on the screen, and seven other command keys such as Menu, Insert, Search, Page, End, etc.

Anything you type in can be saved on the system's external memory, a "microwafer" which looks just like a little microcassette. Each one holds up to 65,000 characters, or about 30 pages of standard double-spaced typing.

The microwafer plugs into the front of the system unit (under the monitor screen) just like a cassette or cartridge. New microwafers cost \$4.00 each. They can

KOMPUTER KORNER

hold up to 10 separate documents, letters, articles etc. (files) each.

Using the System

When the PWP is set up (it takes less than five minutes) and turned on, the screen display first show an SCM trademark, then it displays the MENU. It's interesting to note here that all other WP systems have several, sometimes scores of menus. The PWP has exactly One menu, and that menu displays only eight choices. These eight items include everything you might want to do to *Create, Store, or Print* a document (letter, memo, etc).

This is what the menu looks like

1. **Create or Edit Text**
2. **Set Margins/Tabs/Format**
3. **Print Text**
4. **Store Text to Microwafer**
5. **Recall Document From Microwafer**
6. **Delete Document From Microwafer**
7. **Microwafer Directory**
8. **Initialize New Microwafer**

*Enter Your Selection
Number*

As soon as you enter a number to tell the PWP what you want to do the Menu vanishes, and instructions appear on the screen telling you what to do.

If you don't need to change the standard margins, tabs or anything else in the format, you can just start typing right away. As with any other WP system, there's no need to type in a Carriage Return at the end of a line. Like all other WPs, this one automatically wraps around (word Wraps) to the next line when you reach the end of one line. You only hit the Return (carriage return) when you want to leave an extra space, as for example, with a new paragraph.

On Screen Tutorial

SCM supplies a blank microwafer for you to save the documents or letters on. They also supply a microwafer which has a very brief (less than 10 minutes) user-teaching program on it. This Tutorial consists of eight short lessons, most taking less than a minute. This little instruction course covers only the use of the PWP's editing features (delete, move, copy etc.) It doesn't deal with the many features of the typewriter. That's because they are thoroughly covered in the excellent User's Instruction Manual for the typewriter. There's also a good User's Instruction Manual for the PWP system (as opposed to the typewriter, when used alone).

Both the user's Manual for the PWP and the one for the typewriter have plenty of clear drawings and photographs of the screen to teach you how to use hem.

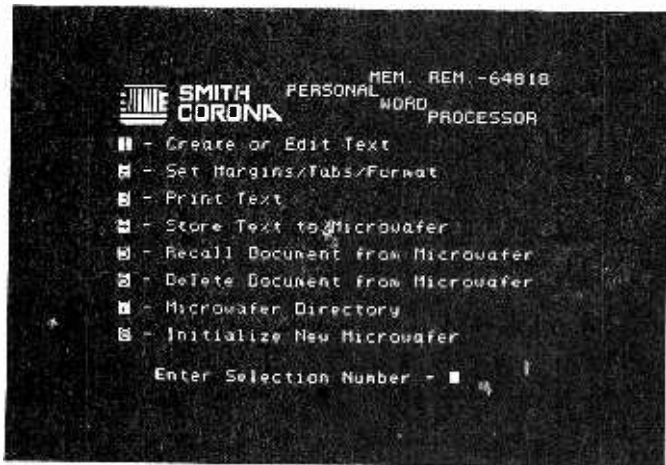

When PWP is fired up this Opening Menu is what you see on the screen. It's called a menu, because you can choose what you want to do, such as Creating or Editing Text (words), Printing, or showing the Directory (list of things stored in the Microwafer memory).

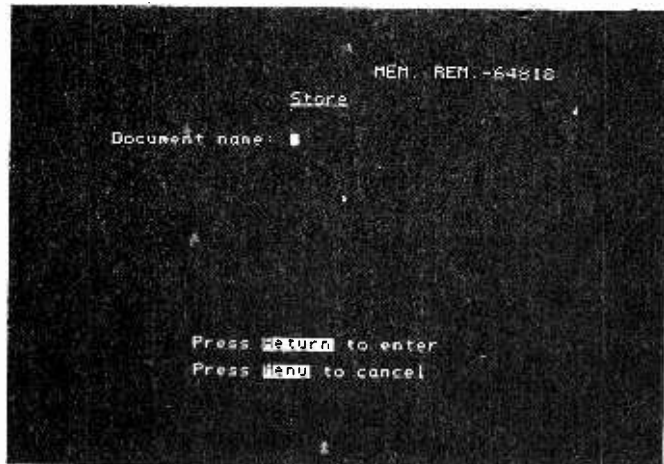

When you choose to Create a new Document this screen appears so you can type in the (new) name you choose for this new document.

However, I was able to use the PWP without referring to either manual by just running through the short (8-lesson) Tutorial once. The microwafer puts it on the screen and it's very easy to follow. This is what's called Computer-Aided Instruction (CAI) and it's very good for teaching most subjects. When CAI is used in schools (or at home) to teach foreign languages, math, or most other academic subjects, it's often even better than taking those subjects in a classroom with a live teacher but no computers. That's because the computer adjusts its speed to the progress of the student(s) and never gets tired or unhappy.

There's no question that CAI, properly used, will (already is beginning to) revolutionize education.

(Continued on page 94)

HOME MICROS FROM TANDY:

THE COLOR COMPUTERS

Starting near \$100, these affordable machines
can be expanded almost indefinitely.
Great variety of programs available.

by Luke Roberts

With all the hoopla about newer, better, and cheaper micros on the horizon, good old Radio Shack (now they call it Tandy whenever possible) just keeps on selling more and more of their basic Color Computers to people who want their children to ease into computers a little at a time, without spending a lot of money all at once. (We'll call the Color Computer "CoCo" from here on.)

Since there are several thousand Radio Shack stores in this country, with all of them offering the Color Computer in its two basic versions, along with dozens of add-on units and software programs, many people are more comfortable buying from a store which has been around for a long time, and which is part of a very large organization

Help Is Everywhere

One of the good things about buying from the Radio Shack Division of Tandy, Inc. is that anything you buy at any of their stores anywhere in the US can be taken into any other store for service under warranty, or just for help in figuring out some problem. And as we all know, even if a micro isn't broken (they rarely do break down) it's very important to have someone available to help solve the various problem that inevitably come up when you're just started using your first micro.

For these, and other reasons, it's no wonder that thousands of people walk into their local Radio Shack computer store or computer department every week, and say, "I'm ready to get started in computers. How can I do that without spending many hundreds of dollars?"

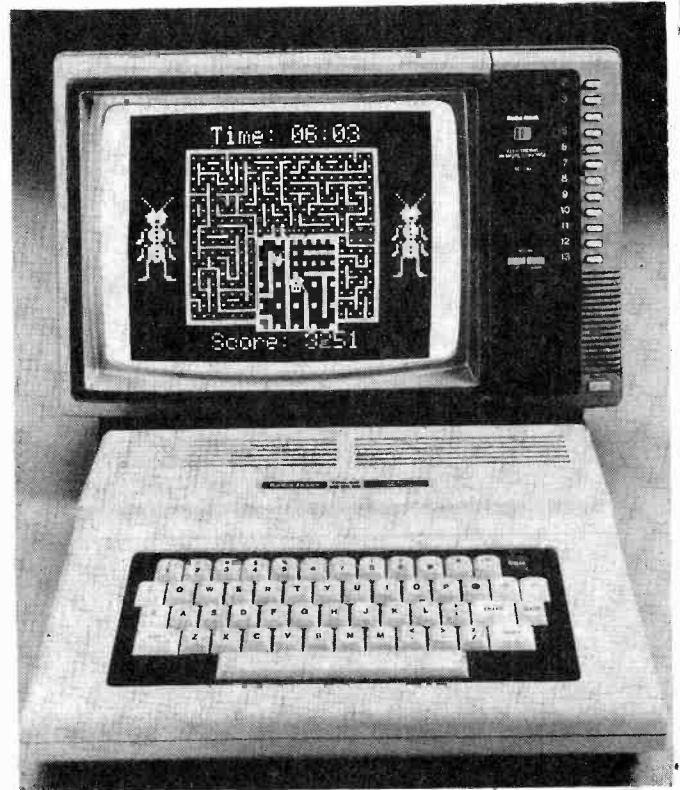

Color Computer 2 is sold as basic model with 16 Kbytes of ROM for \$120, needs only your TV set. Expanded Model 2 with 64K runs advanced programs, costs \$220. With disk drive(s) and printer it can run small business at home.

KOMPUTER KORNER

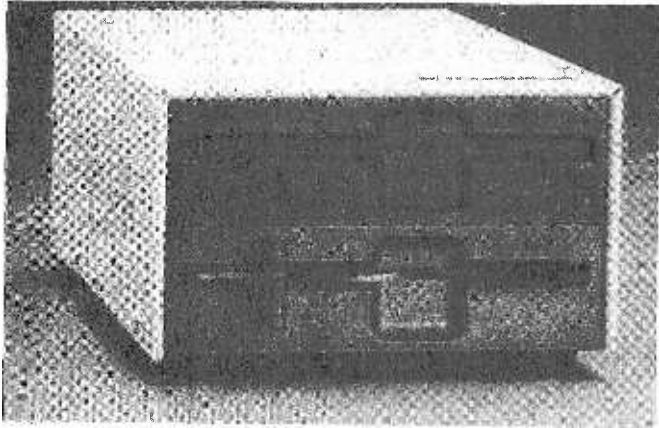

The Color Computer can only do grownup work when it's hooked up to a printer and one or more floppy disk drives. This drive costs \$300 at Radio Shack stores.

In On the Beginning

Radio Shack was selling micros in substantial numbers before anyone else, and along with Apple Computer, has sold more micros than almost anyone else. They had already sold hundreds of thousands of CoCos, and last year they made minor improvements in the CoCo line, so it's now called Color Computer 2. The price of the entry-level model, which has 16 K of memory, is still the same, \$120, but the price of the upgraded Model 2, (32 K) has been lowered from \$260 to \$220.

Radio Shack stores are famous for having sales on various items frequently, and this applies to their computer equipment as well as other products. The lower-price model can also be upgraded to the top model. In addition, the earlier (model 1) CoCo (if it had only 4K of memory) can be upgraded to either 16K or 64K.

When you start shopping for a home computer system, you may be overwhelmed upon first walking into a Radio Shack computer department or center. With small business computer system priced at \$2,000 and large corporations computers starting at \$5,000 it's easy to think you've walked into the wrong store. However, hidden amongst these business oriented systems (usually where you first walked in) is Radio Shack's home computer. CoCo will be first introduced to you playing one of the many eye catching color graphics games available.

Its sound and color graphic capabilities are excellent, but any similarity between a game machine and a powerful home computer stops right there. An attractive, white, compact unit, the CoCo offers a full sized typewriter styled keyboard rivaling those on more expensive machines. The CoCo can be initially bought at either of two prices.

The entry-level micro offers Radio Shack's standard BASIC with 16K RAM memory. This unit is ideal for true starters to learn Basic and about computers for

\$120. A step-up version of this computer includes a powerful Extended BASIC package which adds graphics and advanced programming features to the standard unit. The internal memory is also 16K RAM. The price of the 16K Extended unit is \$150.

More Memory

While 16K RAM version is sufficient for most home uses, which I'll discuss later, the CoCo can also be purchased with all the features of the Extended BASIC unit but with internal memory increased to 64K RAM for the more sophisticated user. The price of the 64K RAM unit is \$220. Each of the smaller CoCos can be upgraded, allowing you to start at the level of your choice.

Cartridges and Cassettes

Programs for the CoCo are available in cartridge format which plug right in, on the side. Most cartridges will work on the 16K standard Basic unit. Programs can also be loaded and saved on cassette. For the more sophisticated user, disk drives can also be added.

A typical initial package might include the Standard Basic 16K CoCo, a computer cassette recorder (you can probably use one you already own with a \$6 cable), one or two programs, a pair of joysticks and some blank cassettes...for a total cost of only about \$225.

Most people starting out with a CoCo use a cassette machine to save programs and games on. But once you get serious with the CoCo you can make it into a grownup system by adding a disc drive, which uses programs on floppy (5¼-inch diameter) discs. This is done by buying the Disk Drive for the CoCo. It's priced at \$300, but frequently on sale at lower prices, particularly if you buy both at the same time. There is a wide variety of programs you can buy on disc for the CoCo, most of them priced from \$30 to \$50.

Good Manuals

Each unit comes with an excellent manual for learning how to operate the computer and "Getting Started With Basic." All the connecting cables are

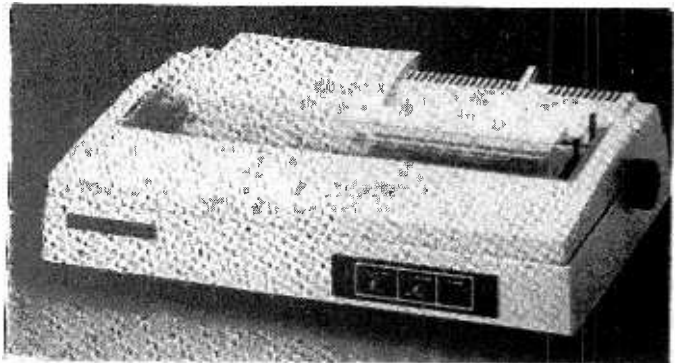

A printer is needed to make any micro into a useful system. They cost from \$200 for Tandy's DMP 105 here, to \$600 or more.

KOMPUTER KORNER

included to get you plugged in and started within a matter of minutes. It should be noted that the CoCo can work on a black and white TV, but color TV is recommended to take advantage of all the attractive colors and graphics. Now that everything is up and running let's get into the good stuff, what can you do with the CoCo?

The question should really be, what can't it do? A powerful computer, the CoCo's uses are virtually unlimited. Whether it's programs from Radio Shack or from other sources, the CoCo has a very wide selection of programs (software). Let me just review some of the primary areas.

Word Processing

First let's talk about Word Processing (writing and editing words). The ability to write a letter, a memo, a report or any correspondence is what a Word Processing program adds to the CoCo. This program allows you to save and edit your text as needed. In the edit mode, you can insert, delete, move and search for text. You no longer will have to retype an entire document to make a few corrections. You just make the correction (only). Radio Shack offers a Word Processing program on cartridge which will run on any version of the CoCo. To the disk version of Word Processing, you can also add a spelling correction program.

Maintaining Lists

Did you ever wonder on which record a certain song was in your record collection? Or how many 1977 commemoratives you have in your stamp collection? Recipe files, a coin collection, baseball card collections or an address/phone book are just some of the uses fulfilled by a Data-Base program. Keeping track of any series of items is easy with a Data-Base program. A Data-Base program is also available on cartridge which will run on any version of the CoCo.

Finances

Money, and keeping track if it is also easy on the CoCo. With a personal finance program you can set up a budget by category by month, and then compare it to your actual expenses. This program will also reconcile your checking account. While it won't add extra money into your account, by giving you the analysis of expenses it can help you save more. Again this program is available on cartridge, and it will run on any version of the CoCo.

The spread sheet program allows you to work with columns of numbers for totals and comparisons. You can change one figure and all the totals will automatically change. This is an excellent program for doing "what if" analysis. And this program is available in cartridge format, and will run on either version of the CoCo.

Other Software

You'll find software available for Real Estate

Investment, Murder Mystery Adventures, Bond Analysis, Accounting, Bookkeeping, and many other types of software. Pick up a copy of Radio Shack's catalog or one of the several magazines published monthly with information on just the CoCo, and you'll get an idea of its breadth and scope.

CoCo Can Talk

You can even add a voice synthesizer and have the CoCo talk to you. A controller board can be programmed to control appliances through the house, or you can use a Touch Pad for creating freehand art work.

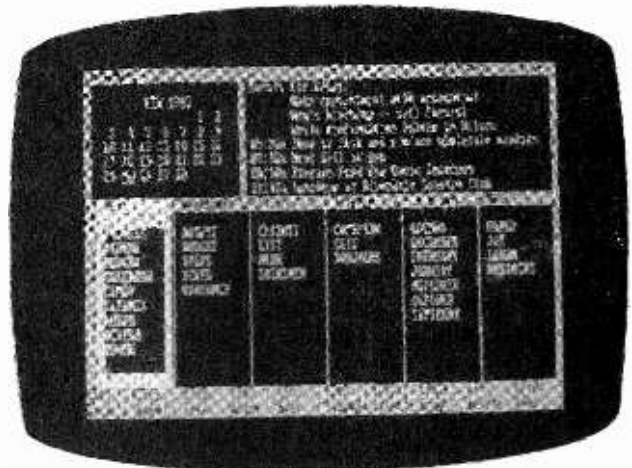

Integrated software package for Coco is DeskMate. It includes a simple WP program, filing, calendar and communications software. \$100 at Radio Shack stores.

Good Backup

The CoCo has an established base of users and is well supported by Radio Shack and outside vendors. The final ingredient which enhances the value of the CoCo is that you always have a place to go for service or problem solving. There are customer service reps at most Radio Shack Computer centers and phone representatives in Ft. Worth, Tx. available to answer questions all day long.

The CoCo, a very sophisticated Computer, will add new dimensions of fun, learning and education to anybody's household.

Plenty of Programs

Educational programs pre-schoolers, such as Sesame Street's letter recognition with Cookie Monster, thru High School, including Algebra, Reading Comprehension, Calculus, Physics, Foreign Language, Effective Writing, History and SAT preparatory programs, just to mention a few.

Learning computer programming is another area for the CoCo. Various languages are available for learning and programming starting with Basic, which is built

into the computer, Pascal, Forth, Cobol, Assembly language and Logo. You might recognize Logo as the most popular language now being taught in most schools.

Games, Too

Entertainment programs also play an important role in the CoCo's make up. You can make all the right pitches, bunt on runner along the base paths, or stretch a double into a triple with Radio Shack's Baseball cartridge. You can also draw pictures with Art Gallery, blast aliens from outer space, and warp from sector to sector in Starblaze. You can determine your biorhythm, play music, handicap the horses, learn how to type, or play chess or checkers. These are only a few of the many games available.

Talk To The Outside

A very exciting area of computer use is Telecommunications. By adding a modem to your CoCo you can communicate with the entire outside computer world, not just another CoCo user. You can "talk" with local Bulletin Boards, which allow local users to leave messages and talk to other computer users. You can also send and receive complete programs via modem.

For a fee, you can also communicate with Database Services, such as Dow Jones, the Source, Compuserve or the Real Estate Network. These services offer an unlimited amount of information and services including: complete and current stock market and corporate financial information; access to encyclopedias; local, national and international news, weather and sports; airline and travel information; buying computer software; shopping at home and Real Estate information. These are just a few of the many, many that can be accessed. There are also some banks beginning to offer Banking at home by computer, including hundreds of Citibank branches in the Northeast.

Home Applications

The CoCo also shines in availability of software in this category. Word processing, data bases for filing, personal finance, tax programs and spreadsheets are some of the programs available in this category. When you start to take advantage of the CoCo's capabilities in these areas, you must consider adding a printer to your system. There are two types of printers to choose from. One is a dot matrix printer and the other is a daisy wheel printer. Speed, quality and price are the difference between the two. The Daisy wheel provides letter quality print (ie. electronic typewriter print) with prices starting at about \$400 (on sales). The dot matrix offers speed almost ten times as fast, with prices starting at about \$200.

Many programs for teaching school subjects, such as math, science, vocabulary, and many other subjects. Many of these, which come on cassette, cost as little as \$20. Here are just a few books available from Radio Shack stores which will help advanced students get further ahead using their CoCo. These cost from five to seven dollars each.

TRS-80 Color Computer & MC-10 Programs. Features 40 programs: games, quizzes, drills, calculators and more.

The Color Computer Playground. Features 42 entertaining and useful programs to help you and your children learn with the computer and about the computer. Programs are educational, simple and grouped by subject area.

Going Ahead With Extended Color BASIC. Describes features of Extended Color BASIC, including advanced graphics, complex sounds and more. Over 210 pages of instructions.

Color Computer Quick Reference Guide. Features functions, ROM subroutines, handy index and more.

Color Computer Graphics. Extensive guide to creating superb color graphics 256 pages. ■

JUNK BOX SPECIAL

shoulder washer. Secure with a 1/4-inch (or smaller, not larger) nut hand-tightened against the shoulder washer. Before going any further check with an ohmmeter to be certain the collector terminal is insulated from the cabinet.

Connecting wires are soldered directly to IC1's terminal leads; use a heat sink such as an alligator clip on each terminal if you have a large (greater than 40 watts) iron. Since the layout is not important, we suggest the arrangement shown, with IC1 positioned between two mounting strips so R1 can span across the strips and be soldered to IC1's collector terminal.

Finally, we come to the meter, a device that has become slightly more expensive than a barrel of Arabian oil. Any meter that can indicate at least the range of 0 to 15 VDC is adequate. The 0-30 VDC meter shown in the photographs was selling in one local store for \$7.95, while we bought ours almost down the block as "surplus" for \$2.99. You might not end up with a meter case that looks suitable for NASA, but the output voltage doesn't care two hoots whether the meter is a modern \$25 dollar model or a surplus-special for a

buck ninety-nine.

Power switch S1 can be a separate SPST as shown in our project, or it can be part of R2. But keep in mind that a separate S1 allows you to turn the supply on and off without affecting voltage control R2's adjustment.

Finally, we come to R1 and R2. You will note that the schematic shown two values for each. One value for each resistor is in brackets (parenthesis). You can use either set of values as long as they are matched. If R2 is 500 ohms R1 is 220 ohms; if R2 is 1000 ohms R1 is 470 ohms. The reason we show both sets of values is because 500 and 1000 ohm potentiometers appear on the surplus market from time to time, but usually not together. This way, you can use whatever is available at low cost.

CHECKOUT. Set potentiometer R2 so the wiper shorts to the end connected to IC1's collector terminal, thereby connecting the collector directly to ground. If you wired R2 correctly it should be full counter-clockwise. Then set S1 to on. The meter should rise instantly to 5 volts DC. As R2 is adjusted clockwise the output voltage should increase to 15 VDC or slightly higher. If R2 can adjust the output voltage only over the range of approximately 12 to 15 VDC, or 12 to 15+ VDC, IC1 is defective or has been damaged. ■

ELECTRONIC TRAINING

cost you both time and money.

Can you settle down to work on a regular daily basis for many months in order to achieve your ends. Or do you need someone to push you along? If the lure of the bar or movie theater is greater than the lure of a new profession, save your money! If you are weak on self discipline, perhaps a regular classroom program is what you need.

On the other hand, you may be a completely different sort of person. Maybe you didn't do well in high school, because classroom work made you restless. Maybe choosing your own study hours and concentrating on a subject that turns you on is the

educational setting in which you will thrive. You may have been bored and confounded by Byron and Keats in your English class, yet be a whiz at analyzing the invisible migrations of electrons through complex circuits.

Some individuals learn quickly. Some more slowly. Often it is the slow learner, even one who nonetheless learns thoroughly, who can be handicapped in a conventional classroom. But given adequate time and a well-designed correspondence program, he may become even more competent in a given job than a fast learner.

So consider carefully your own self and the available electronic courses available through home study programs. If it is the right path for you on your way to a bright occupational future, great! Good luck! ■

BEST BUY WORD PROCESSOR

Learning to Use PWP

To demonstrate how easy it is to learn to use a dedicated WP system like SCM's PWP, here is the entire PWP Tutorial. It takes less than ten minutes to get through it with the system. After I went through it I was able to use all the PWP features to process words just the way I do on a big dedicated WP system such as my \$4,300 DECmate II word processor.

Compact System

The PWP is very compact, except for the typewriter/printer. That's about the size of a standard IBM office Selectric typewriter, though not as high, nor as heavy. It has all the usual features of top-flight office electronic machines, plus the Spell-Check dictionary built in.

The PWP monitor display screen is the same as any small 12-inch monochrome TV set, and the main system unit which it sits on top of is bit over two inches high, about 11-inches square. The microwafer drive is in the front of the system unit, as with most personal computers. The little separate keypad (with its Cursor command keys and seven other PWP command keys) is the size of a pocket calculator.

The PWP can be connected to the following older SCM electronic typewriter models, in addition to the three new SCM electronic machines:

- SE 200
- SD 300
- Citation 300 Messenger
- Citation III Messenger
- Deville III Messenger
- Ultrasonic 250
- Ultrasonic III
- Memory Correct 200
- Memory Correct 300 Messenger

- Memory Correct III
- Memory Correct III Messenger
- Mark II
- Sterling Electronic II

List prices for the three new SCM typewriter/printers are: XE-5000, \$300; XE 6000, \$380; XD7000, \$520.

The PWP, not including typewriter/printer, lists for \$500.

Prices, List and Otherwise

Because there is a big demand for this groundbreaking home word-processing system, there probably won't be many sales or discounts on the PWP for some time. However, experience in the home and small-business office-supply market tells us that after a product has been around for a year or so, competition begins to set in. Thus I expect to see the actual street price of the PWP to go lower after it's been on the market for a while.

If I didn't already have my big dedicated word processor, I'd certainly buy myself an SCM PWP. As it is, I'm giving this one to my son for Christmas.

Disadvantages

Well, you may say, after reading this glowing report on SCM's new and almost-revolutionary word processor. What's the catch? You don't get anything for nothing in this world. If this thing is so good, so easy-to-learn, and so low-priced, what's the catch? Good question.

There's only one disadvantage to the PWP, and it's only a minor one. The external memory, the microwafer storage memory, is fairly slow.

In a busy office it would be a problem. In a home, student, or small office, where the cost of the system, and its ease of learning are important, it's a very small disadvantage, and a small price to pay. Even for most writers, the slow memory-access time should pose no problem. ■

CASSETTE REPAIR

inspect the tape head connections for broken or loose wires. Often, these wires will break off since the head assembly is moved constantly back and forth in loading and play modes. Measure the head resistance across the two terminals (Fig. 13). The tape head

resistance of a mono player is 2000 ohms or less with 1000 ohms or less resistance of the stereo cassette recorder.

The stereo cassette play/record tape head may have several cables attached between terminals and amplifier. A separate cable for play and for recording is found in this type stereo tape head circuit (Fig. 14). If one channel is dead or intermittent, check the

resistance of both channels and compare the two readings. Flex the cables when intermittent sound is found with the player operating. Take a plastic tool and push upon each terminal to locate the defective connection inside the tape head, with the cassette operating. Replace the tape head when found open or intermittent.

Tape Counter Not Working

No movement of the tape counter may be caused with the belt off the pulley or a broken counter belt. Usually, the counter assembly is driven with a small belt from the take-up reel (Fig. 15). It is possible the tape counter may not work after the tape deck is removed from the front piece for repairs and accidentally not replaced. The tape counter assembly may have dry bearings, or gummed up, and not rotate.

No Sound Or Distorted Sound

Try to isolate the no-sound problem to the amplifier section or tape head. Suspect a defective tape head or preamp stage when sound is normal on the left and dead on the right channel. In combination radio-tape players, if the radio plays on both channels and dead on the left channel, suspect a defective left head or preamp circuit. Check for defective function switch, improper DC voltage and transistor or IC output circuits with both dead channels. Weak sound may be caused with a defective tape head, dirty tape head, preamp or output amplifier of one channel. A dirty tape head may prevent playback or recording in one or both channels. If both channels are weak, suspect a defective IC component or improper DC voltage from

the power supply circuits.

A simple click or hum test may be done rather quickly with the blade of a small screwdriver. Turn the sound way up. Touch both ungrounded head terminals and listen for a loud click or hum. Suspect a dead channel when no hum is heard. Now go to the volume control and touch the screwdriver to the center terminal. If hum is heard out both channels, check the preamp stage of the dead channel. In case both channels are dead with the volume control test, suspect a defective IC output component.

Leaky or open transistors may be checked with a transistor digital-multimeter (DMM). A defective IC component may be found with signal in and out tests and accurate voltage measurements. Since many of the latest cassette deck amplifiers contain IC components, signal-tracing methods may be used. When both VU meters are functioning with no sound output, suspect the output IC component or no supply voltage at the IC (Fig 16).

Intermittent sound may result from poor tape head or internal broken connections. A dirty function-switch assembly may produce intermittent sound. If one channel is intermittent, check from tape head to amplifier and speaker.

Distorted sound is usually generated in the output circuits or speaker. Substitute another speaker to check for distortion. Remove one speaker terminal. Remove each output transistor and check for leakage. Check for burned bias resistors. Replace any suspected IC component when one IC component is found in the output. Suspect the output IC or speaker for distortion in only one channel. ■

INDUCTANCE & CAPACITANCE

where X is, in this case, X_c , capacitive reactance.

As an example, let's calculate the impedance of the circuit of Fig. 9.

$$\begin{aligned} Z &= R^2 + X^2 \\ &= (150)^2 + (200)^2 \\ &= 62,500 \\ &= 250 \text{ ohms} \end{aligned}$$

As a further calculation, let us determine the current which will flow as 50 volts is applied to the terminals of the circuit in Fig. 10:

$$\begin{aligned} I &= E/Z, \\ &= 50/250 \\ &= 0.2 \text{ ampere.} \end{aligned}$$

All Together Now

The final question is this: If a circuit includes resistance, inductance and capacitance, all at once, what is its total impedance? An example of such a series circuit is shown in Fig. 10.

Here, 100 volts at 70 Hz is applied across a series circuit of 150-ohms resistance, 1.05 Henry inductance ($X_L = 462$ ohms), and 6.8 μF capacitance ($X_c = 334$ ohms).

As a first step in determining the total impedance, we can draw the 'directions' of the resistance and the two reactances, as shown in Fig. 11.

The first thing that strikes us about Fig. 11 is that the effect of the 'northbound' (inductive) 462 ohms is partially cancelled by the 'southbound' (capacitive) 334 ohms. The *net reactance* of this circuit is:

$$\begin{aligned} X &= X_L - X_c, \\ &= 462 \text{ ohms} - 334 \text{ ohms,} \\ &= 128 \text{ ohms.} \end{aligned}$$

This combining of X_L and X_c by simple subtraction reduces the problem to a simpler one, resembling a problem we've already solved. This is graphically shown in Fig. 12.

Applying the formula for impedance

$$\begin{aligned} Z &= X^2 + R^2, \\ &= (128)^2 + (150)^2, \\ &= 197.2 \text{ ohms.} \end{aligned}$$

The current flow is:

$$\begin{aligned} I &= E/Z, \\ &= 100 \text{ volts}/197.2 \text{ ohms,} \\ &= 0.51 \text{ ampere.} \end{aligned}$$

North vs. South

In the above problem, we saw that the 'northbound' inductive reactance (462 ohms) was very nearly cancelled by the 'southbound' capacitive reactance (334 ohms). It's pretty obvious that by changing some values, or by changing the frequency, we could make

X_L exactly equal to X_C , and they would cancel each other completely, leaving the circuit with no net reactance whatsoever—just 150 ohms of simple resistance. This condition, where $X_L = X_C$ exactly, is called resonance. When a capacitance and inductance are in series there will be one frequency for which their

net reactance will be zero. A parallel capacitance and inductance present a high impedance to a current. By using these circuits you can make filters that will pass or block certain frequencies. But that's another story altogether. ■

OSCILLATING AMPLIFIERS

Don't Get Sloppy

Careless construction can get you into trouble, too. The amplifier shown in Fig. 14 is trying to convert a 10-millivolt input into a 200-ma signal needed by the load, R2. The builder has tied all ground returns to a heavy ground bus, and returned this bus to ground at only one point. Unfortunately, that single ground wire has to carry both the tiny input signal and the large output current. And, since every wire has *some* resistance, the actual circuit includes an 0.06-ohm resistor that does not appear in the original construction's schematic diagram, but must be considered and is shown in Fig. 14.

Again, an uninvited, feedback path has appeared, coupling the output back to the input. In the sketch, the large output current, flowing through the tiny ground-lead resistance, produces a voltage which is even larger than the original input voltage. And, since this voltage is also connected to the input (through the bias resistor R3), the fed-back voltage appears uninverted (and uninvited!) at the input, and will cause the amplifier's power bus back to the input, arriving there with the same polarity as the normal input. True, the signal unintentionally fed back isn't very large, because the unintentionally feedback path provides substantial losses for this stray signal. For example, the signal may arrive back at the input 100 times smaller than it was at the output. However, if the amplifier has a gain of 101, it makes an even larger output signal out of the fed-back signal, which then is fed back as an even larger voltage and oscillation begins.

amplifier to oscillate. What is to be done to convert these oscillators back into well-behaved amplifiers?

What to Do?

The general rule is *divide and conquer*. In the example just above, we can conquer the oscillation by dividing the ground returns, making sure that the high-current output circuits and the sensitive input circuits have their own private and individual paths to the power supply. See Fig. 15.

Short leads to the input connector are also helpful in squashing oscillations.

The misbehaving decoupling network, R1 and C2 in Fig. 13, can also be brought under control by dividing the network into two decoupling networks as shown in Fig. 16.

The stray capacities causing the unwelcome phase shifter to hide in the best divide-and-conquer approach to this amplifier are harder to exorcise. Your amplifier is to put feedback around only a pair of stages instead of three or more. This way, there are only two pairs of stray Rs and Cs lurking in the amplifier, and it takes at least three such pairs to make an oscillator.

The coupling capacitors, which combined to make a phase shifter in the very first example, can be prevented from ganging up on the amplifier and making it oscillate by making the product of each capacitor times its associated resistor (called the "RC product") 5 or 10 times larger or smaller than the other RC products. For example, in the three-stage feedback amplifier which has all its base resistors the same values, you could make the three coupling capacitors 2 μ F, and 10 μ F, and 60 μ F, respectively. Again, you have divided the coupling capacitors into three widely-separated values, and conquered the oscillation. ■

QUARTZ CRYSTAL MAGIC

alone. The *pole* is used here also, energy feeds back through the grid-plate capacitance, and the *pole* selects only the parallel-resonant frequency. (shorting the rest to ground).

ECO. The electron-coupled Pierce oscillator (Fig. 9C) is similar to the basic Pierce. The tuned circuit in the plate offers the possibility of emphasizing a harmonic—an RF choke may be used instead if freedom from tuning is desired and fundamental-frequency operation will suffice.

GPO. One of the most popular oscillators of all time is the Colpitts Crystal oscillator of Fig. 9D, sometimes known as the *grid-plate* oscillator. The feedback arrangement here consists of the two capacitors in the grid circuit; feedback is adjusted by means of the 150 pF variable capacitor (the greater the capacitance, the less the feedback) until reliable oscillation is obtained. Like the other three oscillators, this circuit employs the

crystal *pole* frequency.

Since all four of these oscillator circuits utilize the *pole* for frequency control, exact frequency adjustment capability may be obtained by connecting a 3-30 pF trimmer capacitor in parallel with the crystal.

Crystal oscillators may, of course be built with transistors, too. Two typical circuits are shown in Fig. 10. Feedback mechanisms differ somewhat because of the basic differences between tubes and transistors. In general, transistorized oscillators are more stable.

As a Clock. To use a crystal as the timing element of a clock, an oscillator identical to those shown in Figs. 9 and 10 is the starting point. Crystal frequency is chosen at a low, easily-checked value such as 100 kHz. This frequency is then divided and redivided by synchronized multivibrators to produce one cycle-per-second pulses. These may then be counted by computer counting circuits. In chips that divide by 10, or other programmed values, do a far better job serving as a clock because of the overall accuracy and low cost of parts. ■

Get switched on

THE FUN WAY TO LEARN ELECTRONICS

Lab Test
C&E HOBBY
HANDBOOKS
For Yourself



LEARN ABOUT ELECTRONICS:
Electricity and Magnetism,
Inductance and Capacitance

NEWEST SOLID STATE TECHNIQUES:
Thermistors, Op Amps,
IC Learning Aids

SECRETS OF RADIO:
Phase and Frequency Facts,
AVC, Superhet Circuitry,
Power Supplies, Antennas

ALL ABOUT COMMUNICATIONS:
Low Frequencies, FM, TV,
Shortwaves, Satellites,
Microwaves

“PLUG IN”  to the excitement and satisfaction of

C&E HOBBY HANDBOOKS

- ★ ORDER COPIES OF BACK ISSUES...
- ★ MAIL THIS COUPON FOR DETAILS...

TO: WORLDWIDE PUBLICATIONS INC.
P.O. BOX # 5206
NORTH BRANCH, N.J. 08876

S086

FROM: (Please Print)

Name: _____

Address: _____

City & State: _____ Zip: _____

BUILD 20 RADIO AND ELECTRONICS CIRCUITS

PROGRESSIVE HOME RADIO-TV COURSE

Now Includes

- ★ 12 RECEIVERS
- ★ 3 TRANSMITTERS
- ★ SQ. WAVE GENERATOR
- ★ SIGNAL TRACER
- ★ AMPLIFIER
- ★ SIGNAL INJECTOR
- ★ CODE OSCILLATOR
- ★ No Knowledge of Radio Necessary
- ★ No Additional Parts or Tools Needed
- ★ Solid State Circuits
- ★ Vacuum Tube Circuits

YOU DON'T HAVE TO SPEND HUNDREDS OF DOLLARS FOR A RADIO COURSE

The "Edu-Kit" offers you an outstanding PRACTICAL HOME RADIO COURSE at a rock-bottom price. Our Kit is designed to train Radio & Electronics Technicians, making use of the most modern methods of home training. You will learn radio theory, construction practice and servicing. THIS IS A COMPLETE RADIO COURSE IN EVERY DETAIL. You will learn how to build radios, using regular schematics; how to wire and solder in a professional manner; how to service radios. You will work with the standard type of punched metal chassis as well as the latest development of Printed Circuit chassis.

You will learn the basic principles of radio. You will construct, study and work with RF and AF amplifiers and oscillators, detectors, rectifiers, test equipment. You will learn and practice code, using the Progressive Code Oscillator. You will learn and practice trouble-shooting, using the Progressive Signal Tracer, Progressive Signal Injector, Progressive Dynamic Radio & Electronics Tester, Square Wave Generator and the accompanying instructional material.

You will receive training for the Novice, Technician and General Classes of F.C.C. Radio Amateur License. You will build Receiver, Transmitter, Square Wave Generator, Code Oscillator, Signal Tracer and Signal Injector circuits, and learn how to operate them. You will receive an excellent background for television, Hi-Fi and Electronics.

Absolutely no previous knowledge of radio or science is required. The "Edu-Kit" is the product of many years of teaching and engineering experience. The "Edu-Kit" will provide you with a basic education in Electronics and Radio, worth many times the low price you pay. The Signal Tracer alone is worth more than the price of the kit.

THE KIT FOR EVERYONE

You do not need the slightest background in radio or science. Whether you are interested in Radio & Electronics because you want an interesting hobby, a well paying business or a job with a future, you will find the "Edu-Kit" a worth-while investment. Many thousands of individuals of all

ages and backgrounds have successfully used the "Edu-Kit" in more than 79 countries of the world. The "Edu-Kit" has been carefully designed, step by step, so that you cannot make a mistake. The "Edu-Kit" allows you to teach yourself at your own rate. No instructor is necessary.

PROGRESSIVE TEACHING METHOD

The Progressive Radio "Edu-Kit" is the foremost educational radio kit in the world, and is universally accepted as the standard in the field of electronics training. The "Edu-Kit" uses the modern educational principle of "Learn by Doing." Therefore you construct, learn schematics, study theory, practice trouble shooting—all in a closely integrated program designed to provide an easily-learned, thorough and interesting background in radio. You begin by examining the various radio parts of the "Edu-Kit." You then learn the function, theory and wiring of these parts. Then you build a simple radio. With this first set you will enjoy listening to regular broadcast stations, learn theory, practice testing and trouble-shooting. Then you build a more advanced radio, learn more advanced theory and techniques. Gradually, in a progressive manner, and at your own rate, you will find yourself constructing more advanced multi-tube radio circuits, and doing work like a professional Radio Technician.

Included in the "Edu-Kit" course are Receiver, Transmitter, Code Oscillator, Signal Tracer, Square Wave Generator and Signal Injector Circuits. These are not unprofessional "breadboard" experiments, but genuine radio circuits, constructed by means of professional wiring and soldering on metal chassis, plus the new method of radio construction known as "Printed Circuitry." These circuits operate on your regular AC or DC house current.

THE "EDU-KIT" IS COMPLETE

You will receive all parts and instructions necessary to build twenty different radio and electronics circuits, each guaranteed to operate. Our Kits contain tubes, tube sockets, variable, electrolytic, mica, ceramic and paper dielectric condensers, resistors, tie strips, hardware, tubing, punched metal chassis, Instruction Manuals, hook-up wire, solder, selenium rectifiers, coils, volume controls, switches, solid state devices, etc.

In addition, you receive Printed Circuit materials, including Printed Circuit chassis, special tube sockets, hardware and instructions. You also receive a useful set of tools, a professional electric soldering iron, and a self-powered Dynamic Radio and Electronics Tester. The "Edu-Kit" also includes Code Instructions and the Progressive Code Oscillator, in addition to F.C.C. Radio Amateur License training. You will also receive lessons for servicing with the Progressive Signal Tracer and the Progressive Signal Injector, a High Fidelity Guide and a Quiz Book. You receive Membership in Radio-TV Club, Free Consultation Service, Certificate of Merit and Discount Privileges. You receive all parts, tools, instructions, etc. Everything is yours to keep.

Progressive "Edu-Kits" Inc., P.O. Box #238, Dept. 501 IJ, Hewlett, N.Y. 11557



Reg. U.S. Pat. Off.

Training Electronics Technicians Since 1946

FREE EXTRAS

• SET OF TOOLS

- SOLDERING IRON
- ELECTRONICS TESTER
- PLIERS-CUTTERS
- VALUABLE DISCOUNT CARD
- CERTIFICATE OF MERIT
- TESTER INSTRUCTION MANUAL
- HIGH FIDELITY GUIDE QUIZZES
- TELEVISION BOOK
- TROUBLE-SHOOTING BOOK
- MEMBERSHIP IN RADIO-TV CLUB:
- CONSULTATION SERVICE • FCC:
- AMATEUR LICENSE TRAINING
- PRINTED CIRCUITRY

SERVICING LESSONS

You will learn trouble-shooting and servicing in a progressive manner. You will practice repairs on the sets that you construct. You will learn symptoms and causes of trouble in home, portable and car radios. You will learn how to use the professional Signal Tracer, the unique Signal Injector and the dynamic Radio & Electronics Tester. While you are learning in this practical way, you will be able to do many a repair job for your friends and neighbors, and charge fees which will far exceed the price of the "Edu-Kit." Our Consultation Service will help you with any technical problems you may have.

FROM OUR MAIL BAG

Ben Valerio, P. O. Box 21, Magna, Utah: "The Edu-Kits are wonderful. Here I am sending you the questions and also the answers for them. I have been in Radio for the last seven years, but like to work with Radio Kits, and like to build Radio Testing Equipment. I enjoyed every minute I worked with the different kits; the Signal Tracer works fine. Also like to let you know that I feel proud of becoming a member of your Radio-TV Club."

Robert L. Shuff, 1534 Monroe Ave., Huntington, W. Va.: "I thought I would drop you a few lines to say that I received my Edu-Kit, and was really amazed that such a bargain can be had at such a low price. I have already started repairing radios and phonographs. My friends were really surprised to see me get into the swing of it so quickly. The Trouble-shooting Tester that comes with the Kit is really swell, and finds the trouble, if there is any to be found."

SOLID STATE

Today an electronics technician or hobbyist requires a knowledge of solid state, as well as vacuum tube circuitry. The "Edu-Kit" course teaches both. You will build vacuum tube, 100% solid state and combination ("hybrid") circuits.

PRINTED CIRCUITRY

At no increase in price, the "Edu-Kit" now includes Printed Circuitry. You build a Printed Circuit Signal Injector, a unique servicing instrument that can detect many Radio and TV troubles. This revolutionary new technique of radio construction is now becoming popular in commercial radio and TV sets.

A Printed Circuit is a special insulated chassis on which has been deposited a conducting material which takes the place of wiring. The various parts are merely plugged in and soldered to terminals.

Printed Circuitry is the basis of modern Automation Electronics. A knowledge of this subject is a necessity today for anyone interested in Electronics.

Please rush me free literature describing the Progressive Radio-TV Course with Edu-Kits. No Salesman will call.

NAME

ADDRESS

CITY & STATE ZIP

PROGRESSIVE "EDU-KITS" INC.

P.O. Box #238, Dept. 501 IJ, Hewlett, N.Y. 11557