

1989
**Popular
 Electronics**

ELECTRONICS HOBBYISTS handbook™

ISSUE #1

\$2.95 U.S.
 \$3.75 CANADA

An exciting
 collection of over
 35 projects!

Checking chips is a
 snap with our *Digi-Lyzer
 IC Tester*

Update *Grandpa's
 Antique Radio* by adding
 a solid-state twist

Build *Fred the Head* and
 always have someone to
 talk to

Hear the songs of nature
 with our *Electronic Wind
 Chime*

Have a sneaky good
 time with the *Little FM
 Snooper*

Use our *Fishing Guide*
 and get the ones that
 got away

Let the *Phone Sentry*
 stand guard against
 nuisance calls

Keep the forces of evil at
 bay with the *Electronic
 Dazer*

Build the *Flashmate*
 light meter and
 bring professional-
 studio quality
 to your home
 black and
 white and
 color
 photographs
 (See page 104)



**Fun to Build!
 Fun to Use!**

Appliances answer their
 master's call with the
Vox Box

Keep sensitive
 components safe with
 the *Temperature-
 Controlled Soldering
 Station*

The fun's right on target
 with the *One-Shot
 Shooting Gallery*

Save bucks and
 batteries with the pro-
 quality *Economy NiCd
 Battery Charger*

Let the *Waterbugg
 Alarm* keep surprise
 basement floods from
 bugging you

Troubleshooting enters
 the third dimension
 when you build the *3D
 Oscilloscope*

Don't curse the
 darkness, use the *Night
 Owl* to light up the night

Treat yourself to an ever-
 changing hourly
 serenade with *HourTune*

Stand out in any crowd
 when you wear the *Gee
 Whiz Badge*

Create eerie
 sound effects
 the solid-state
 way with the
*Digital
 Theremin*
 (See Page 142)



Give your sense of
 hearing a stereo
 boost when you build the
Bionic Ears
 (See page 11)



INTEGRATED CIRCUITS

Part	Price
7400 TTL	
7400N	1.50
7401	1.50
7401N	1.50
7402	1.50
7402N	1.50
7403	1.50
7403N	1.50
7404	1.50
7404N	1.50
7405	1.50
7405N	1.50
7406	1.50
7406N	1.50
7407	1.50
7407N	1.50
7408	1.50
7408N	1.50
7409	1.50
7409N	1.50
7410	1.50
7410N	1.50
7411	1.50
7411N	1.50
7412	1.50
7412N	1.50
7413	1.50
7413N	1.50
7414	1.50
7414N	1.50
7415	1.50
7415N	1.50
7416	1.50
7416N	1.50
7417	1.50
7417N	1.50
7418	1.50
7418N	1.50
7419	1.50
7419N	1.50
7420	1.50
7420N	1.50
7421	1.50
7421N	1.50
7422	1.50
7422N	1.50
7423	1.50
7423N	1.50
7424	1.50
7424N	1.50
7425	1.50
7425N	1.50
7426	1.50
7426N	1.50
7427	1.50
7427N	1.50
7428	1.50
7428N	1.50
7429	1.50
7429N	1.50
7430	1.50
7430N	1.50
7431	1.50
7431N	1.50
7432	1.50
7432N	1.50
7433	1.50
7433N	1.50
7434	1.50
7434N	1.50
7435	1.50
7435N	1.50
7436	1.50
7436N	1.50
7437	1.50
7437N	1.50
7438	1.50
7438N	1.50
7439	1.50
7439N	1.50
7440	1.50
7440N	1.50
7441	1.50
7441N	1.50
7442	1.50
7442N	1.50
7443	1.50
7443N	1.50
7444	1.50
7444N	1.50
7445	1.50
7445N	1.50
7446	1.50
7446N	1.50
7447	1.50
7447N	1.50
7448	1.50
7448N	1.50
7449	1.50
7449N	1.50
7450	1.50
7450N	1.50
7451	1.50
7451N	1.50
7452	1.50
7452N	1.50
7453	1.50
7453N	1.50
7454	1.50
7454N	1.50
7455	1.50
7455N	1.50
7456	1.50
7456N	1.50
7457	1.50
7457N	1.50
7458	1.50
7458N	1.50
7459	1.50
7459N	1.50
7460	1.50
7460N	1.50
7461	1.50
7461N	1.50
7462	1.50
7462N	1.50
7463	1.50
7463N	1.50
7464	1.50
7464N	1.50
7465	1.50
7465N	1.50
7466	1.50
7466N	1.50
7467	1.50
7467N	1.50
7468	1.50
7468N	1.50
7469	1.50
7469N	1.50
7470	1.50
7470N	1.50
7471	1.50
7471N	1.50
7472	1.50
7472N	1.50
7473	1.50
7473N	1.50
7474	1.50
7474N	1.50
7475	1.50
7475N	1.50
7476	1.50
7476N	1.50
7477	1.50
7477N	1.50
7478	1.50
7478N	1.50
7479	1.50
7479N	1.50
7480	1.50
7480N	1.50
7481	1.50
7481N	1.50
7482	1.50
7482N	1.50
7483	1.50
7483N	1.50
7484	1.50
7484N	1.50
7485	1.50
7485N	1.50
7486	1.50
7486N	1.50
7487	1.50
7487N	1.50
7488	1.50
7488N	1.50
7489	1.50
7489N	1.50
7490	1.50
7490N	1.50
7491	1.50
7491N	1.50
7492	1.50
7492N	1.50
7493	1.50
7493N	1.50
7494	1.50
7494N	1.50
7495	1.50
7495N	1.50
7496	1.50
7496N	1.50
7497	1.50
7497N	1.50
7498	1.50
7498N	1.50
7499	1.50
7499N	1.50
7500	1.50
7500N	1.50

INTEGRATED CIRCUITS

Part	Price
Micro.	
7501	1.50
7501N	1.50
7502	1.50
7502N	1.50
7503	1.50
7503N	1.50
7504	1.50
7504N	1.50
7505	1.50
7505N	1.50
7506	1.50
7506N	1.50
7507	1.50
7507N	1.50
7508	1.50
7508N	1.50
7509	1.50
7509N	1.50
7510	1.50
7510N	1.50
7511	1.50
7511N	1.50
7512	1.50
7512N	1.50
7513	1.50
7513N	1.50
7514	1.50
7514N	1.50
7515	1.50
7515N	1.50
7516	1.50
7516N	1.50
7517	1.50
7517N	1.50
7518	1.50
7518N	1.50
7519	1.50
7519N	1.50
7520	1.50
7520N	1.50
7521	1.50
7521N	1.50
7522	1.50
7522N	1.50
7523	1.50
7523N	1.50
7524	1.50
7524N	1.50
7525	1.50
7525N	1.50
7526	1.50
7526N	1.50
7527	1.50
7527N	1.50
7528	1.50
7528N	1.50
7529	1.50
7529N	1.50
7530	1.50
7530N	1.50
7531	1.50
7531N	1.50
7532	1.50
7532N	1.50
7533	1.50
7533N	1.50
7534	1.50
7534N	1.50
7535	1.50
7535N	1.50
7536	1.50
7536N	1.50
7537	1.50
7537N	1.50
7538	1.50
7538N	1.50
7539	1.50
7539N	1.50
7540	1.50
7540N	1.50
7541	1.50
7541N	1.50
7542	1.50
7542N	1.50
7543	1.50
7543N	1.50
7544	1.50
7544N	1.50
7545	1.50
7545N	1.50
7546	1.50
7546N	1.50
7547	1.50
7547N	1.50
7548	1.50
7548N	1.50
7549	1.50
7549N	1.50
7550	1.50
7550N	1.50

SILICON TRANSISTORS

Part	Price
1.6Watt	
2N3055	1.50
2N3055A	1.50
2N3055B	1.50
2N3055C	1.50
2N3055D	1.50
2N3055E	1.50
2N3055F	1.50
2N3055G	1.50
2N3055H	1.50
2N3055I	1.50
2N3055J	1.50
2N3055K	1.50
2N3055L	1.50
2N3055M	1.50
2N3055N	1.50
2N3055O	1.50
2N3055P	1.50
2N3055Q	1.50
2N3055R	1.50
2N3055S	1.50
2N3055T	1.50
2N3055U	1.50
2N3055V	1.50
2N3055W	1.50
2N3055X	1.50
2N3055Y	1.50
2N3055Z	1.50
2N3055AA	1.50
2N3055AB	1.50
2N3055AC	1.50
2N3055AD	1.50
2N3055AE	1.50
2N3055AF	1.50
2N3055AG	1.50
2N3055AH	1.50
2N3055AI	1.50
2N3055AJ	1.50
2N3055AK	1.50
2N3055AL	1.50
2N3055AM	1.50
2N3055AN	1.50
2N3055AO	1.50
2N3055AP	1.50
2N3055AQ	1.50
2N3055AR	1.50
2N3055AS	1.50
2N3055AT	1.50
2N3055AU	1.50
2N3055AV	1.50
2N3055AW	1.50
2N3055AX	1.50
2N3055AY	1.50
2N3055AZ	1.50
2N3055BA	1.50
2N3055BB	1.50
2N3055BC	1.50
2N3055BD	1.50
2N3055BE	1.50
2N3055BF	1.50
2N3055BG	1.50
2N3055BH	1.50
2N3055BI	1.50
2N3055BJ	1.50
2N3055BK	1.50
2N3055BL	1.50
2N3055BM	1.50
2N3055BN	1.50
2N3055BO	1.50
2N3055BP	1.50
2N3055BQ	1.50
2N3055BR	1.50
2N3055BS	1.50
2N3055BT	1.50
2N3055BU	1.50
2N3055BV	1.50
2N3055BW	1.50
2N3055BX	1.50
2N3055BY	1.50
2N3055BZ	1.50
2N3055CA	1.50
2N3055CB	1.50
2N3055CC	1.50
2N3055CD	1.50
2N3055CE	1.50
2N3055CF	1.50
2N3055CG	1.50
2N3055CH	1.50
2N3055CI	1.50
2N3055CJ	1.50
2N3055CK	1.50
2N3055CL	1.50
2N3055CM	1.50
2N3055CN	1.50
2N3055CO	1.50
2N3055CP	1.50
2N3055CQ	1.50
2N3055CR	1.50
2N3055CS	1.50
2N3055CT	1.50
2N3055CU	1.50
2N3055CV	1.50
2N3055CW	1.50
2N3055CX	1.50
2N3055CY	1.50
2N3055CZ	1.50
2N3055DA	1.50
2N3055DB	1.50
2N3055DC	1.50
2N3055DD	1.50
2N3055DE	1.50
2N3055DF	1.50
2N3055DG	1.50
2N3055DH	1.50
2N3055DI	1.50
2N3055DJ	1.50
2N3055DK	1.50
2N3055DL	1.50
2N3055DM	1.50
2N3055DN	1.50
2N3055DO	1.50
2N3055DP	1.50
2N3055DQ	1.50
2N3055DR	1.50
2N3055DS	1.50
2N3055DT	1.50
2N3055DU	1.50
2N3055DV	1.50
2N3055DW	1.50
2N3055DX	1.50
2N3055DY	1.50
2N3055DZ	1.50
2N3055EA	1.50
2N3055EB	1.50
2N3055EC	1.50
2N3055ED	1.50
2N3055EE	1.50
2N3055EF	1.50
2N3055EG	1.50
2N3055EH	1.50
2N3055EI	1.50
2N3055EJ	1.50
2N3055EK	1.50
2N3055EL	1.50
2N3055EM	1.50
2N3055EN	1.50
2N3055EO	1.50
2N3055EP	1.50
2N3055EQ	1.50
2N3055ER	1.50
2N3055ES	1.50
2N3055ET	1.50
2N3055EU	1.50
2N3055EV	1.50
2N3055EW	1.50
2N3055EX	1.50
2N3055EY	1.50
2N3055EZ	1.50
2N3055FA	1.50
2N3055FB	1.50
2N3055FC	1.50
2N3055FD	1.50
2N3055FE	1.50
2N3055FF	1.50
2N3055FG	1.50
2N3055FH	1.50
2N3055FI	1.50
2N3055FJ	1.50
2N3055FK	1.50
2N3055FL	1.50
2N3055FM	1.50
2N3055FN	1.50
2N3055FO	1.50
2N3055FP	1.50
2N3055FQ	1.50
2N3055FR	1.50
2N3055FS	1.50
2N3055FT	1.50
2N3055FU	1.50
2N3055FV	1.50
2N3055FW	1.50
2N3055FX	1.50
2N3055FY	1.50

1989 **ELECTRONICS** Popular **HOBBYISTS** Electronics. **handbook** TM

THE MAGAZINE FOR THE ELECTRONICS ACTIVIST!

CONTENTS

EDITORIAL	Julian S. Martin	2
NEW PRODUCTS		4
ELECTRONICS LIBRARY		8
BIONIC EARS	Charles D. Rakes	11
3D OSCILLOSCOPE	Homer Tilton	14
FRED-THE-HEAD	Richard L. Pearson	23
SOUND-ACTIVATED SWITCH	Richard Hampton	28
TEMPERATURE-CONTROLLED SOLDERING STATION	Ladisav Hala	32
PILOT CARRIER FREQUENCY STANDARD	Luther M. Stroud	38
DIGI-LYZER IC TESTER	Walter W. Schopp	41
BUILD THE HANDS-ON FISHING GUIDE	Tom Fox	46
GEE-WHIZ BADGE	Walter W. Schopp	52
PHONE SENTRY	Luther M. Stroud	56
SUPER STROBE	Dwight E. Patrick	59
HOURTUNE	Robert E. Damm	63
GRANDPA'S ANTIQUE RADIO	Homer L. Davidson	67
ELECTRONIC WIND CHIME	Charles D. Rakes	72
ELECTRONIC DAZER	Rick Duker	75
THE WATERBUGG	Dave Sweeney	77
VOX BOX	Jay Glowaoki	79
ALL-BAND FIELD STRENGTH METER	Herb Friedman	82
SERIAL BUS SWITCH FOR THE COMMODORE-64	Mike Hinshaw	85
TORMENTOR	Herb Friedman	87
NIGHT OWL	Jonathan Allen Gordon	90
ECONOMY NICD BATTERY CHARGER	Ladislav and Peter Hala	93
HIDE-A-WAY STEALTH	J. L. Pearson	98
FLASH MATE	Frank I. Gilpin	104
SOLAR POWERED HOUSE NUMBER	Colin Dawson	107
GAME FEEDER CONTROLLER	James H. Bran	113
TIME CAPSULE	Frank I. Gilpin	115
BUILD THE POOR MAN'S IBM PC/XT	Herb Friedman	117
BUILD A SMOKE SECURITY ALARM	Adolph Mangieri	121
THE DIRTY LITTLE FM SNOOPER	Ricky Shea	125
GASEOUS-STATE TRANSMITTER	Larry Lisle	128
THE ONE SHOT SHOOTING GALLERY	Evert Fruitman	138
SMOKE BUSTER	Richard J. Pearson	131
BUILD THE DIGITAL THEREMIN	C. R. Fischer	142
BUILD A BINAURAL MIKESSET	Thomas Krehbiel	145
THE TEST-A-MATIC	Bob Grossblatt	147
DIGITAL LOGIC PROBE	Robert A. Young	149
AD INDEX		164

As a service to readers, **1989 Popular Electronics Electronics Hobbyists Handbook** publishes available plans or information relating to newsworthy products, techniques and scientific and technological developments. Because of possible variances in the quality and condition of materials and workmanship used by readers, we disclaim any responsibility for the safe and proper functioning of reader-built projects based upon or from plans or information published in this magazine.

Since some of the equipment and circuitry described in **1989 Popu-**

lar Electronics Electronics Hobbyists Handbook may relate to or be covered by U.S. patents, we disclaim any liability for the infringement of such patents by making, using, or selling of any such equipment or circuitry, and suggest that anyone interested in such projects consult a patent attorney.

1989 Popular Electronics Electronics Hobbyists Handbook is published annually by Gernsback Publications Inc. All rights reserved. Printed in U.S.A. Single copy price \$2.95, Canada \$3.75. ©Copyright Gernsback Publications Inc., 1989.

1989 **ELECTRONICS**
Popular HOBBYISTS
Electronics handbook™

Larry Steckler

EHF, CET

Editor-In-Chief & Publisher

Art Kleiman

Editorial Director

Julian S. Martin, KA2GUN

Editor

Carl Laron

Managing Editor

Robert A. Young

Associate Editor

John J. Yacono

Associate Editor

Byron G. Wels, K2AVB

Associate Editor

Teri Scaduto

Assistant Editor

Kathryn Campbell

Editorial Assistant

Joseph J. Carr, K4IPV

Marc Ellis

Jeffrey K. Holtzman

Don Jensen

Charles D. Rakes

Marc Saxon

Contributing Editors

Ruby M. Yee

Production Director

Karen S. Tucker

Production Manager

Robert A. W. Lowndes

Editorial Associate

Marc Spiwak

Editorial Associate

Marcella Amoroso

Production Assistant

Andre Duzant

Technical Illustrator

Russell C. Truelson

Assistant Illustrator

Injae Lee

Assistant Illustrator

Jacqueline P. Cheeseboro

Circulation Director

Michele Torrillo

P.E. Bookstore

BUSINESS AND EDITORIAL OFFICES

Gernsback Publications, Inc.

500-B Bi-County Blvd.

Farmingdale, NY 11735

1-516-293-3000

Fax: 1-516-293-3115

President: **Larry Steckler**

Vice President: **Cathy Steckler**

Advertising Sales Offices listed on page 164.

Composition by
Mates Graphics



The publisher has no knowledge of any proprietary rights which will be violated by the making or using of any items disclosed in this issue.



INTRODUCING A NEW HANDBOOK

The editors of **Popular Electronics** are besieged with hundreds of letters each month from readers requesting plans and/or diagrams for gadgets and projects they would like to build. Often, the letters state that they once saw such a project in our magazine, or another one.

That's not too surprising. Every once in a while, a project comes along that captures the imagination of anyone that sees it. Years after we've forgotten where or when we saw something, the memory of the project remains vivid.

Letter after letter asks us about projects named *Fred the Head*, *Dirty Little Snooper*, *Wind Chimes*, and the like. All of the aforementioned were projects published by the editors of **Popular Electronics**, and its predecessor, **Hands-on Electronics**, during the last three years.

Because of the volume of mail, we decided it was time to publish a retrospective of the best in electronics projects for the true hobbyist. That's why you're now reading this issue of the **Popular Electronics Electronics Hobbyists Handbook!**

You asked us for another look at some of our most popular projects, and here it is; we hope you enjoy it! But to get the most out of this magazine, you've got to take out the old soldering iron and get to work. Have fun, learn about electronics, and build some of the many fascinating and useful projects from these pages.

And let us know how you made out. Were you pleased with our plans and the project's performance? Did you improve the project beyond the plans we offered? Was the variety of articles satisfying to you? Just tell us what is on your mind. We'll be watching the mailbox.

Julian S. Martin, KA2GUN
Editor

SELECT 5 BOOKS for only \$3⁹⁵

(values to \$134.70)
and get a **FREE Gift!**

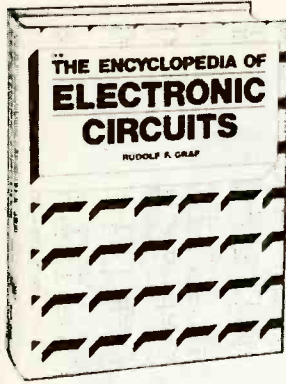
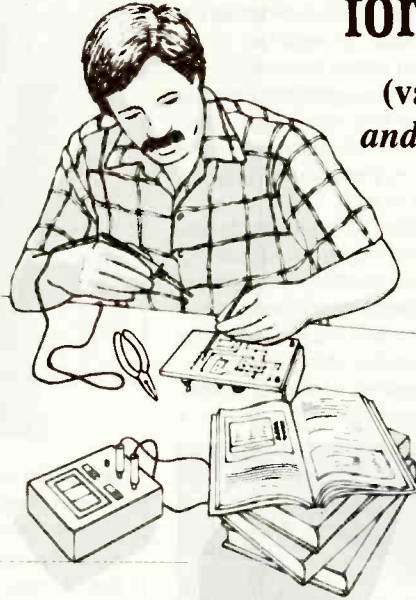

1938 \$60.00
Counts as 3



2613 \$24.95



1199P \$18.95



1625P \$16.95

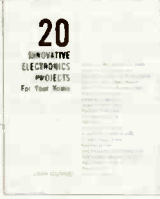

2947 \$21.95



1536P \$9.95

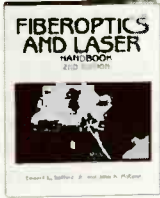

2981 \$24.95



2925 \$16.95



2707 \$26.95
Counts as 2



2092 \$24.95



1367P \$18.95

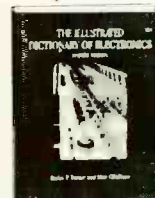

2900 \$16.95
Counts as 2



2885 \$16.95

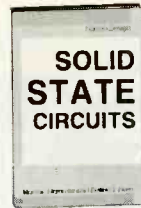

2975 \$24.95



2809 \$26.95
Counts as 2



1599P \$17.95



2750P \$17.95

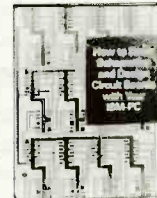

2731P \$14.95

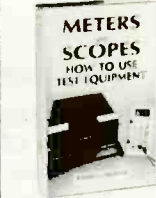

3034 \$19.95

2826P \$15.95

Electronics projects . . . ideas . . . the latest technology
all at up to 50% off publishers' prices!

Membership Benefits • Big Savings. In addition to this introductory offer, you keep saving substantially with members' prices of up to 50% off the publishers' prices. • **Bonus Books.** Starting immediately, you will be eligible for our Bonus Book Plan, with savings of up to 80% off publishers' prices. • **Club News Bulletins.** 14 times per year you will receive the Book Club News, describing all the current selections—mains, alternates, extras—plus bonus offers and special sales, with scores of titles to choose from. • **Automatic Order.** If you want the Main Selection, do nothing and it will be sent to you automatically. If you prefer another selection, or no book at all, simply indicate your choice on the reply form provided. As a member, you agree to purchase at least 3 books within the next 12 months and may resign at any time thereafter. • **Ironclad No-Risk Guarantee.** If not satisfied with your books, return them within 10 days without obligation. • **Exceptional Quality.** All books are quality publishers' editions especially selected by our Editorial Board.

©1989 ELECTRONICS BOOK CLUB®, Blue Ridge Summit, PA 17294-0810
All books are hardcover unless number is followed by a "P" for paperback (Publisher's Prices shown)

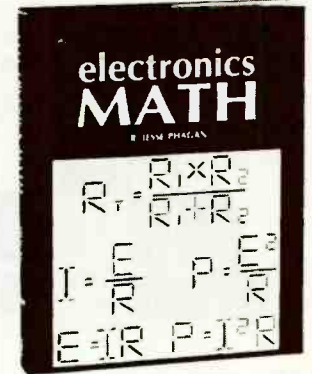

1962 \$22.95

FREE when you join!

15 Easy Electronic Projects From Delton T. Horn
Projects you can build—some unique, some old favorites—from the author's vast treasury of electronics know-how.

\$7.95 value!



ELECTRONICS BOOK CLUB®

Blue Ridge Summit, PA 17294-0810

Please accept my membership in the Electronics Book Club® and send the 5 volumes listed below, plus my FREE copy of *Delton T. Horn's All-Time Favorite Electronic Projects* (3105P), billing me \$3.95 plus shipping and handling charges. If not satisfied, I may return the books within ten days without obligation and have my membership cancelled. I agree to purchase at least 3 books at regular Club prices (plus shipping and handling) during the next 12 months and may resign any time thereafter.

Name _____
Address _____
City _____
State _____ Zip _____ Phone _____
Signature _____

Valid for new members only. Foreign applicants will receive special ordering instructions. Canada must remit in U.S. currency. This order subject to acceptance by the Electronics Book Club® PEHH489



2995 \$25.95

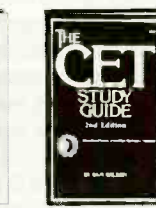

2941 \$21.95

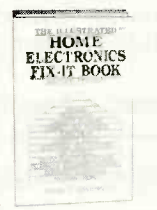

2483 \$25.95

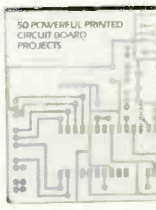

2972 \$23.95



1532P \$14.95

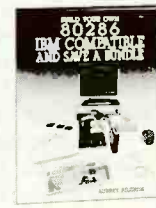

3031 \$24.95

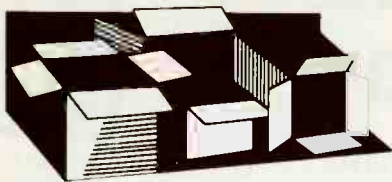

New Products

To obtain additional information on new products covered in this section from the manufacturer, please circle the item's code number on the Free Information Card

EMERGENCY CB RADIO

Midland's Model 77-909 is a 40-channel, emergency CB radio. It is small enough to stow easily in a glove compartment or under a car seat, and a one-touch Channel-9 memory button provides instant access to the emergency-communications channel that can bring help quickly on the road.

The 77-909's has ETR frequency control for pinpoint channel-tuning accuracy,



fully variable squelch control, and a high-intensity green LED readout system. Separate up and down channel-selector buttons with two speeds provide fast tuning. The unit includes a built-in condenser microphone for improved audio transmissions, a pre-tuned telescopic antenna with magnetic-mount base, and a rugged vinyl carrying case.

The 77-909 emergency two-way radio has a suggested retail price of \$149.00. For further information, contact Midland International, Consumer Products Division, 1690 North Topping, Kansas City, MO 64120.

CIRCLE 75 ON FREE INFORMATION CARD

REMOTE SURGE SUPPRESSOR

The Model RW-500 remote surge suppressor from Perma Power Electronics protects a computer workstation from transient surges on the power line, and permits the entire system to be turned on or off from the computer monitor switch.

The surge suppressor has five outlets—a master and four auxiliaries. Its design incorporates a unique circuit that monitors

the power flowing through the master outlet, so that when any equipment that is connected to the master outlet is switched on, the other four outlets are switched on simultaneously. That allows the monitor—or whatever peripheral is plugged into the master outlet—to serve as a convenient control point for the entire workstation, while the surge-suppressor strip and power cords are hidden neatly out of sight.

The RW-500 offers computer-grade protection in the normal mode (line-to-neutral), and in both common modes (line-to-ground and neutral-to-ground). It responds in one nanosecond, and has a maximum energy dissipation of 480 joules, 160 in each mode. The surge suppressor's clamping threshold is 225-volts peak, and it is rated for a



maximum transient voltage of greater than 6,000 volts.

The UL-listed RW-500 remote surge suppressor has a suggested retail price of \$99.90. For further information, contact Perma Power Electronics, 5601 West Howard Avenue, Chicago IL 60648.

CIRCLE 76 ON FREE INFORMATION CARD

HEAVY-DUTY DMM'S

Beckman Industrial's HD153 is one of their HD150 Series of 3 1/2-digit, auto-ranging digital multimeters. Offering hands-free usage and audible signaling, those heavy-duty meters are designed to go anywhere, under all conditions. Beckman claims that the DMM's are rugged enough to survive a 10-foot drop to concrete; they warranty the meters against outside contamination for five years and for two years against other damage (except in the case of abuse).

The meters are designed so that the user can keep his hands and eyes on the job. The HD153 features a "Skyhook" that can be flipped out from its back so that the meter can be hung up, as well as a tilt stand. With the auto-ranging feature, after function selection the proper range is set automatically by an internal microprocessor and readings are presented audibly. By listening to the continuous tone, which is proportional to the magnitude of the reading, the user does not have to look at the meter. The HD153 also points out intermittents by emitting a "crackling" sound as they are detected—faster than the information would



appear on any DMM display. Using standard test leads, the HD153 detects the presence of most standard logic signals, and alerts the user with a beep. The combination of those features is intended to make the HD 153 "attention-free." (On those occasions when hands-on usage is preferred, the unit is light, compact, and comfortable to hold.)

The DMM features DC-voltage ranges of 200mV, and 2, 20, 200, and 1500 volts, with resolution of 100µV and accuracy is 0.25% + 1 digit (4% + 1 digit for 1.5-KV range). AC voltage ranges are 200mV, and 2, 20, 200, and 1000 volts, with resolution of 100µV and accuracy of 75% + 3 digit + 300 µV (for the 45Hz-1kHz band) and 2.0% + 7 digit + 300µV (for the 1 kHz-2kHz band). AC- and DC-current ranges are 20mA, 200mA, and 10A with resolution of 10 µA.

The HD 153 digital multimeter—complete with battery and fuses installed, a spare 250mA/600V fuse, test leads, and operator's manual—has a suggested retail price of \$199.99. For further information, contact Beckman Industrial Corporation, Instrumentation Products Division, 3883 Ruffin Road, San Diego, CA 92123-1989.

CIRCLE 77 ON FREE INFORMATION CARD

PORTABLE CELLULAR PHONE

With the addition of its optional battery and carrying-case system, the Nokia M-10 cellular telephone becomes truly portable. The Portable Kit comes with a gray Cordura carrying case, a cigarette-lighter adapter, and a swivel antenna. The battery has a pouch that matches, and snaps onto, the carrying case. Together, with the M-10, it all adds up to a complete, modular portable system.

The Nokia M-10 includes 832-channel capacity, hands-free operation, and A/B system select. The handset's LCD display and 16-key pad are backlit for evening use. The

display indicates system select, electronic-lock status, roaming, no-service indication, alert, in use, and "select" (used prior to activating any of the phone's functions). The phone also features a call timer, single keystroke redial, unanswered-call indicator, and touch-tone compatibility (DTMF) to allow use of such special services as



voice mailboxes, answering machines, and an external speaker jack.

The battery provides up to four hours of standby or 20 minutes of talk time. A one-hour "quick charge" provides 80% of the power. The battery can be attached—in its pouch—for complete mobility, or removed for simple car-to-car transfers and operation (powered through the cigarette-lighter adapter).

The M-10 cellular telephone has a suggested retail price of \$875.00. The complete Portable Kit and battery has a suggested retail price of \$170.00. For more information, contact *Nokia-Mobira Inc.*, 2300 Tall Pines Drive, Suite 100, Largo, FL 34641.

CIRCLE 82 ON FREE INFORMATION CARD

HIGH-DEFINITION TUNER/AMPLIFIER

Nakamichi's Model TA-3A is a 75-watt, high-definition tuner/amplifier that is designed to be the focal point of a complete audio/video home-entertainment system. It allows existing Nakamichi customers to upgrade their systems without replacing their current components, and features STASIS output circuitry and unified system remote control. The unit provides remote control of a CD player and two cassette decks (including azimuth control on decks with an azimuth-control feature), as well as arm-chair control of power; volume; muting; and station, band, and source selection.

The TA-3A accesses three external audio/video sources (Video 1, Video 2, and Tape-2/VCR) and three audio-only sources (CD, Phono, and Tape 1) as well as its own AM/FM stereo tuner. Pre-Out/Main-In jacks allow the user to connect a surround-sound processor, a subwoofer, or other audio signal-processing equipment at the ideal point in the signal path. A video output is pro-

CONSUMER FORUM

New solid-state and digital TV sets, stereos, and video recorders are tougher to repair than old-fashioned tube type sets and require special training for the service technician who works on them.

Only a few states have laws requiring competency tests for licensing technicians who repair consumer electronics, but fifteen years ago the International Society of Certified Electronic Technicians (ICET) began its own certification program to qualify these technicians and those in industry. To carry the CET designation, technicians must have four years experience and pass a rigid examination on general electronics and a specific area of expertise such as audio or radio-TV.

Many consumers look for a Certified Electronic Technician in the shop when they need any electronic item repaired.

Free Consumer Checklist

A consumer checklist for selecting a service shop is available free by sending a stamped, self-addressed envelope to: Checklist, ISCET, 2708 West Berry, Fort Worth, TX 76109. The list reminds consumers to check such items as "Does the business have the parts for your particular brand?" "Did you get an estimated price?" and "Did you check this company with the Better Business Bureau?"



Modern electronic equipment such as digital TVs or stereos should be repaired by specially trained people.

available free by sending a stamped, self-addressed envelope to: Checklist, ISCET, 2708 West Berry, Fort Worth, TX 76109. The list reminds consumers to check such items as "Does the business have the parts for your particular brand?" "Did you get an estimated price?" and "Did you check this company with the Better Business Bureau?"

Employers

Willing workers available now at as little as 1/2 your usual cost.

This is your chance to get help you've needed, but thought you couldn't afford.

No business too large or too small. Call your private industry council or write National Alliance of Business, P.O. Box 7207, Washington, D.C. 20044

A Public Service of
The Publication



MAGIC!

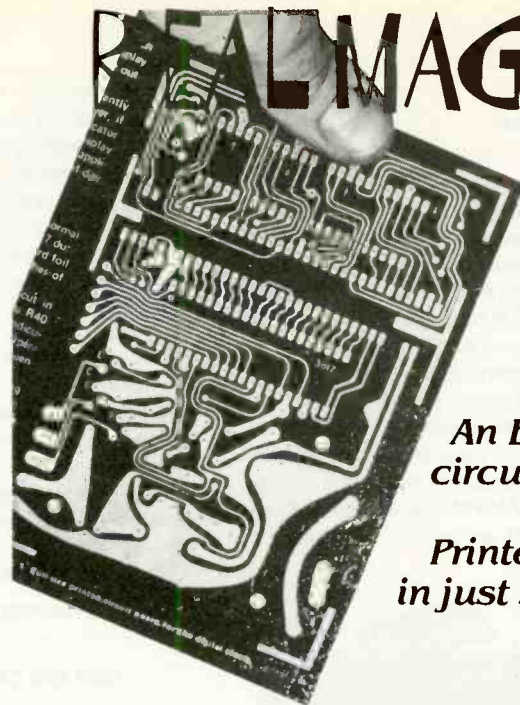

An ETCHED
circuit board
from a
Printed PAGE
in just 3 Hours

The ER-4 PHOTO ETCH KIT gives you the tools, materials and chemicals to make your own printed circuit boards. The patented Pos-Neg™ process copies artwork from magazines like this one without damaging the page. Use the circuit patterns, tapes and drafting film to make your own 1X artwork. Or try the Direct Etch™ system (also included), to make single circuit boards without artwork. The ER-4 is stocked by many electronic parts distributors, or order direct, postpaid.

ER-4 PHOTO ETCH KIT (NJ and CA residents add sales tax) . . . \$38.00

DATAK'S COMPLETE CATALOG lists hundreds of printed circuit products and art patterns. Also contains dry transfer letter sheets and electronic title sets for professional looking control panels. **WRITE FOR IT NOW!**

The DATAK Corporation • 3117 Paterson Plank Road • North Bergen, NJ 07047

CIRCLE 16 ON FREE INFORMATION CARD

You got it to work? Good!



NOW MAKE IT LOOK GOOD

Let DATAK be your designing partner. Use our dry transfer title sets to put that finishing touch to your custom project. Over 2200 titles plus alphabets and numbers insure that you'll have the words you need. Switch markings and dial plate arcs are in a companion set. Use DATAKOAT spray for complete protection. Sprays are not mailable.

948 Blk (949 Wht) 10 pt. 105" Electronic Titles (24 sheets) . . . \$12.50
9581 Blk (9591 Wht) 12 pt. 125" Electronic Titles (24 sheets) . . . 12.95
968 Blk, Wht, Red asst. Meter dial & Switch Markings (12 sheets) . . . 12.95
04177 DATAKOAT Gloss Spray (12 oz) . . . 5.75
04178 DATAKOAT Matte Spray (12 oz) . . . 5.75

Minimum order: \$20.00 (add 7% shipping. NJ and CA also add sales tax)

WRITE FOR A FULL CATALOG AND SAMPLES TODAY
DATAK Corp. • 3117 Paterson Plank Rd. • N. Bergen, NJ 07047

CIRCLE 15 ON FREE INFORMATION CARD

New Products

vided to drive a viewing monitor.

Independent selectors permit viewing and listening to one source while copying another; the "Record-Out" selector allows audio/video recording from either video source to the Tape-2/VCR output, and two-way audio dubbing between the Tape-1 and the Tape-2/VCR equipment. Both the video-monitor and the VCR-record outputs are buffered by discrete 3-stage wideband video amplifiers for optimum recording and viewing.

The tuner/amplifier features a quartz-synthesized AM/FM stereo tuner with 10 station presets and a choice of manual or



auto-seek tuning. The tone controls' effect is purposely limited to the extremes of the audio range so that substantial boost or cut can be applied there without altering the midrange response. Other features in-

clude audio mute and variable loudness contour that tracks the reduction in bass and treble hearing sensitivity as the listening level is reduced.

The TA-3A uses a STASIS output configuration; it neither requires nor uses "global" feedback to reduce distortion. That makes the amplifier inherently stable with every loudspeaker, and keeps its output impedance uniform with frequency—resulting in a louder and cleaner amplifier that can drive "difficult" speakers.

The TA-3A high-definition tuner/amplifier has a suggested retail price of \$795.00. For additional information, contact Naka-michi America Corporation, 19701 South Vermont Avenue, Torrance, CA 90502; Tel. 800-421-2313; in California, 800-223-1521; in Canada, 800-663-6358.

CIRCLE 79 ON FREE INFORMATION CARD

HIGH-END CAR SPEAKERS

The models *TS-U160* (pictured) and *TS-U130* represent the top of Pioneer's "Sound Series" line of car speakers. Aimed at high-end buyers, both speakers feature dual-strontium magnets, a carbon-fiber-blend polypropylene cone woofer, and a titanium dome tweeter, for a full range of audio response.

The *TS-U160* is a 6 1/2-inch, two-way, door-

mount speaker that offers 100-watts maximum power and features a frequency response of 30 to 30,000 Hz and a sensitivity rating of 89 dB. The 5 1/4-inch door-mount *TS-U130* is rated at 60 watts and has a measured frequency response of 37 to 30,000 Hz and 88-dB sensitivity.



The *TS-U160* and *TS-U130* car speakers have suggested retail prices of \$180.00 and \$150.00, respectively. For further information, contact Pioneer Electronics (USA) Inc., 2265 E. 220th Street, P.O. Box 1720, Long Beach, CA 90801-1720.

CIRCLE 78 ON FREE INFORMATION CARD

ANTENNA TUNER

MFJ Enterprises' 3-kilowatt Model MFJ-986 is a T-network tuner that uses a single differential capacitor in place of two variable capacitors. That makes tuning easier and more accurate due to minimum SWR at only one setting, with only two controls to adjust. It also gives users a broadband response that eliminates constant retuning.

The antenna tuner covers 1.8 to 30 MHz continuously, including all MARS and WARC bands. Its roller inductor allows the user to keep the SWR down to absolute minimum. A 3-digit turns counter and spinner knob offer the precise inductance control necessary to instantly return to a favorite frequency. A lighted, two-color, peak-and-average reading, cross-needle SWR/wattmeter lets the user read forward and reflected power and SWR at a glance. It also has a directional coupler for more



accurate SWR and power readings over a wider frequency range.

A 6-position antenna switch offers selection between two coaxial lines and/or random wires (direct or through the tuner), balanced line, and external dummy load. A current balun for balanced lines reduces

ALL ELECTRONICS CORP.

WE STOCK OVER 4,000 ITEMS...

CALL OR WRITE FOR OUR
FREE 56 PAGE CATALOG

of parts for all your projects...

RESISTORS • CAPACITORS •
DIODES CABLES • BRIDGE
RECTIFIERS • LAMPS • CHOKE
COILS • CRYSTALS • RELAYS •
I.C.'S • CRIMP CONNECTORS •
HEAT SINKS • MOTORS •
SUB MINIATURE D CONNECTORS •
TRANSISTORS • FUSES •
POWER SUPPLIES • JACKS • PLUGS •
SWITCHES • FANS • PERF BOARD •
SHRINK TUBING • TIE WRAPS • TOOLS • KEYPADS •
VIDEO ACCESSORIES • S.C.R.'S • TRANSFORMERS •
TELEPHONE ACCESSORIES • RIBBON CABLE • CIRCUIT
BREAKERS • VOLTAGE REGULATORS •
AND MANY OTHER ITEMS



MAIL ORDERS TO:
ALL ELECTRONICS
P.O. BOX 567
VAN NUYS, CA 91408

TWX-5101010183
(ALL ELECTRONIC)

OUTSIDE THE U.S.A.
SEND \$2.00 POSTAGE
FOR A CATALOG!!

ORDER TOLL FREE
800-826-5432
INFO: (818)904-0524
FAX: (818)781-2653
MINIMUM ORDER \$10.00
NO C.O.D.



When someone in your family gets cancer, everyone in your family needs help.

Nobody knows better than we do how much help and understanding is needed. That's why our service and rehabilitation programs emphasize the whole family, not just the cancer patient.

Among our regular services we provide information and guidance to patients and families, transport patients to and from treatment, supply home care items and assist patients in their return to everyday life.

Life is what concerns us. So you can see we are even more than the research organization we are so well known to be.

No one faces cancer alone.

AMERICAN CANCER SOCIETY

feedline radiation that causes RF, field-pattern distortion, and TVI.

The MFJ-986 antenna tuner, complete with a one-year unconditional guarantee, costs \$239.95. For further information, contact MFJ Enterprises, Inc., P.O. Box 494, Mississippi State, MS 39762; Tel. 800-647-1800.

CIRCLE 71 ON FREE INFORMATION CARD

ALL-MODE TRANSCEIVER

Heath's SB-1400 transceiver provides all-mode, all-band coverage with 100 watts of transmit power on all nine HF amateur bands. It is aimed at beginning and experienced ham operators, as well as those who are interested in mobile operations.



The SB-1400 has 25-watt maximum AM output, and 0.25- μ V (or better) sensitivity. It offers dual VFO's, RIT, a built-in 500-Hz

CW filter, computer interface, receiver squelch in all modes, and "split" operation. Twenty memories hold favorite frequencies, and controls—including selectable AGC action—are conveniently arrayed on the front panel.

Available accessories include a 20-amp power supply with built-in speaker, FM module, handheld microphone, mobile bracket, and a switching relay that might be required for some linear amplifiers.

The SB-1400 all-mode transceiver, with user's manual, has a suggested net price of \$799.95. For more information, contact Heath Company, Department 350-036, Benton Harbor, MI 49022; Tel. 1-800-44-HEATH.

CIRCLE 80 ON FREE INFORMATION CARD

HANDHELD DIGITAL MULTIMETER

Triplet's Model 2200 handheld digital multimeter features overload protection of up to 450 volts on all ohmmeter circuitry for safety, and a ruggedized case for durability. The DMM also offers a large, high-contrast 3 1/2-digit LCD readout, a single rotary switch, low-battery indicator, and auto-zero and auto-polarity functions. It measures from 200-millivolts to 1000-volts DC in 5 ranges; from 200 volts to 750 volts AC in two ranges; 200-mi-



croamps to 2-amps DC in 5 ranges; 200 ohms to 2 megohms in two ranges; and diode-test and FE measurements.

The Model 2200 handheld digital multimeter—including a standard 9-volt battery, a pair of test leads, a spare 2-amp fuse, and an instruction manual—costs \$45.00. For further information, contact Triplet Corporation, One Triplet Drive, Bluffton, OH 45817; Tel. 1-800-TRIPLET.

CIRCLE 84 ON FREE INFORMATION CARD

HOLD IT ANYWHERE YOU WANT IT!

PanaVise electronic work holding systems allow you to position, tilt and rotate your projects without removing them from their holding devices! With over 30 years experience and made-in-USA quality, PanaVise ensures reliable, long-lasting service.



MULTI-PURPOSE WORK CENTER: Self-Centering Extra Wide Opening Head (opens to 9"), famous "split ball" Standard Base (moves in three planes), and convenient Tray Base Mount (with parts wells) handle difficult to hold items with ease! Model #350. \$52.95.



STANDARD PANAVISE: Our most popular vise, the Standard PanaVise is an extremely versatile, useful workbench tool. Jaws open a full 2.25", and the patented "split ball" base tilts, turns and rotates through three planes. One convenient control knob locks work into any position! This durable, all-purpose mini-vise stands about 6" tall and will deliver years of rugged service. Model #301. \$33.95.



ELECTRONIC WORK CENTER: A complete combination to make work areas more efficient and manageable! Circuit Board Holder gently, but firmly, holds PCB's up to 12" wide. Add our Standard Base (moves in three planes), Tray Base Mount (with parts wells), and Solder Station (self-centers wire and holds iron at perfect angle) for a great combo! Model #324. \$54.95.

PANAVISE

See your local electronics supplier or contact PanaVise for the source nearest you:
PanaVise Products, Inc.; 2850 E. 29th Street;
Long Beach, CA 90806; (213) 595-7621

Be an FCC LICENSED ELECTRONIC TECHNICIAN!



No costly School. No commuting to class. The Original Home-Study course prepares you for the "FCC Commercial Radiotelephone License". This valuable license is your "ticket" to thousands of exciting jobs in Communications, Radio-TV, Microwave, Computers, Radar, Avionics and more! You don't need a college degree to qualify, but you do need an FCC License. **No Need to Quit Your Job or Go To School** This proven course is easy, fast and low cost! **GUARANTEED PASS** — You get your FCC License or money refunded. **Send for FREE facts now. MAIL COUPON TODAY!**

COMMAND PRODUCTIONS

FCC LICENSE TRAINING, Dept. 204
P.O. Box 2824, San Francisco, CA 94126

Please rush **FREE** details immediately!

NAME _____

ADDRESS _____

CITY _____

STATE _____

ZIP _____

consider the SOURCE

Make **MOUSER Electronics** your factory-authorized source for over 80 quality electronic component manufacturers like:

AUGAT, NEC, TECCOR, RCA, GE, & SGS-Thomson.

And then add: coast-to-coast distribution, same-day shipping, toll-free ordering and the full support of MOUSER's 25 years of proven customer service experience.

Call today for your complimentary subscription to the latest **MOUSER Electronics Catalog.**

2401 Hwy 287 N.
Mansfield, Tx 76063

1-800-992-9943

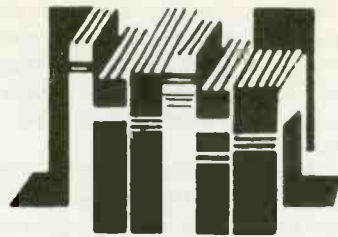

Electronics Library

To obtain additional information on the books and publications covered in this section from the publisher, please circle the item's code number on the Free Information Card

TUNE IN ON TELEPHONE CALLS: Scanner & Shortwave Frequency Directory

by Tom Kneitel, K2AES

Not many people are aware that their "private" conversations on cellular and cordless phones, and on many other modern communications devices, are being broadcast over the airwaves on HF, VHF, and UHF frequencies, where they can be overheard by anyone with a shortwave receiver or a police scanner. Despite (or, perhaps, because of) virtually unenforceable anti-eavesdropping laws, listening in has become a hot "insider" pastime—and a tool for intelligence-gathering and law-enforcement agencies, and for private investigators.

This book is an all-purpose manual and frequency guide to that new area of communications monitoring. It discusses the many radio services in the U.S. and Canada where such calls take place, including cellular, cordless, ship-to-shore, and high-seas transmissions, and the laws regarding those services. Written in an easy-to-understand style, the book discusses monitoring techniques, receiving equipment, and antennas.

The book contains thousands of listings of station locations. It also contains the actual operating frequencies within all shortwave and scanner bands for locating telephone conversations and one-way radio-

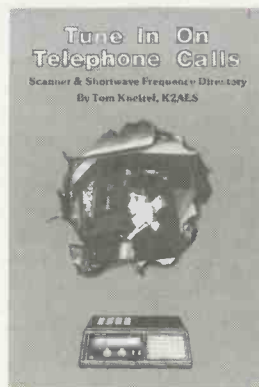

pager messages. Readers will learn how to hear those—and even calls from Air Force 1—on base, handheld, and mobile receivers and scanners. No technical expertise or expensive equipment is required.

Tune in on Telephone Calls: Scanner & Shortwave Frequency Directory is available for \$12.95 plus \$2.00 shipping (N.Y. residents add sales tax) from CRB Research Books, Inc., P.O. Box 56, Com-mack, NY 11725.

CIRCLE 70 ON FREE INFORMATION CARD

ILLUSTRATED PAGEMAKER

by Phyllis Moore

This book is intended to help readers master the skills needed to create typeset-quality books, brochures, and newsletters using PageMaker—a desktop publishing program that runs under Microsoft Windows on IBM PC's and compatibles. Detailed descriptions of all the PageMaker commands are included, along with examples and practical suggestions for applying those commands to real situations.

After a brief introduction and an explanation of how to get the program up and



running, the topics discussed are arranged alphabetically, in "learning modules." Designed to be both a handy reference guide and a comprehensive user's manual, the alphabetic arrangement makes it easy for experienced users to find what they're looking for quickly. For beginners, there is a recommended learning sequence; by following that sequence, a beginning user is guided from the simplest, most-often used commands through the more advanced, less common commands.

Each module contains a description of the typical operations of the command, and learn-by-doing exercises. The self-contained modules (each begins with starting up PageMaker and ends with leaving it) can each be used as an isolated unit, although it is integrated into the recommended learning sequence.

Illustrated PageMaker is available for \$19.95 from Wordware Publishing Inc., 1506 Capital Avenue, Plano, TX 75074.

CIRCLE 72 ON FREE INFORMATION CARD

LOTUS 1-2-3 TIPS AND TRICKS

by Gene Weisskopf

Designed for all levels of Lotus 1-2-3 users, this book offers dozens of specific shortcuts, pointers, and cautions for the most efficient use of that program. The "tips" it offers are bits of sound advice on productive work habits to ensure success. "Tricks," on the other hand, are hidden shortcuts or combinations of Lotus features that produce unexpected results. "Cautions" are just that: warnings about specific topics or general bad habits that are potentially damaging.

The book covers those features that should be mastered by all Lotus users. It

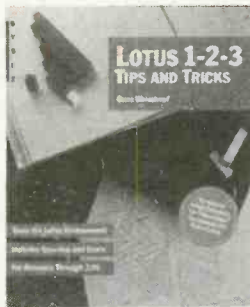

is a basic, step-by-step guide as well as a compilation of handy techniques. Readers learn how to use macros to increase the system's power; to plan and create clean worksheets that are easy to work with; to quickly gain access to DOS; to find hidden errors that are disrupting calculations; to use impressive graphs to present data; and to increase the clarity, speed, and accuracy of all operations. It describes how to use the often-neglected @ functions for working with text and dates, and how to use the @d function to get more value from the database.

Also included are details on two popular Lotus add-in programs: "Learn" (for recording macros) and "Speedup" (for making the system work faster). Techniques for troubleshooting the printing process help readers take control of their printouts. For those who are considering upgrading to 1-2-3 Release 3, the author takes a look at the new features it offers.

Lotus 1-2-3 Tips and Tricks is available for \$21.95 from Sybex, Inc., 2021 Challenger Drive #100, Alameda, CA 94501.

CIRCLE 87 ON FREE INFORMATION CARD

VCR CONNECTIONS GUIDE TV Accessory Hookup Made Easy

by Louis E. Frenzel, Jr.

Lou Frenzel has a well-deserved reputation for demystifying complex subjects, and this perplexing topic hits close to home: how to connect VCR's and other television accessories for maximum performance. Fren-



zel, with the help of the Howard W. Sams engineering staff, helps you meet that challenge successfully.

Watching TV used to be a simple thing. But with the array of signal sources and accessories available today, it sometimes seems as if you need a degree in engineering to get everything working properly. This book details—in plain English, with clear illustrations—how to hook up VCR's, cable converters, video games, stereos, satellite receivers, and other increasingly popular add-on devices.

The book explains the theory of inter-

HITACHI SCOPES AT DISCOUNT PRICES

<p>V-212 \$399 List \$560 Save \$161</p> <p>20MHz Dual Trace Oscilloscope</p> <p>All Hitachi scopes include probes, schematics and Hitachi's 3 year warranty on parts and labor. Many accessories available for all scopes.</p>	<p>V-425 List \$995 \$835</p> <ul style="list-style-type: none"> DC to 40MHz Dual Channel CRT Readout Cursor Meas DC Offset All Magnifier Compact Size 	<p>V-1060 List \$1595 \$1,285</p> <ul style="list-style-type: none"> DC to 100MHz Dual Channel Delayed Sweep CRT Readout Sweep Time Autorangeing Trigger Lock 2mV Sensitivity 																								
<p>V-223 20MHz D.T. 1mV sens. Delayed Sweep, DC Offset, Vert. Mode Trigger</p> <p>V-422 40MHz D.T. 1mV sens. DC Offset Vert. Mode Trigger, All Mag</p> <p>V-423 40MHz D.T. 1mV sens. Delayed Sweep, DC Offset, All Mag</p> <p>V-860 60MHz D.T. 2mV sens. Delayed Sweep, CRT Readout</p> <p>V-1065 100MHz D.T. 2mV sens. Delayed Sweep, CRT Readout, Cursor Meas</p> <p>V-1100A 100MHz Q.T. 1mV sens. Delayed Sweep, CRT Readout, DVM, Counter</p> <p>V-1150 150MHz Q.T. 1mV sens. Delayed Sweep, Cursor Meas, DVM, Counter</p>	<table border="1"> <thead> <tr> <th>LIST</th> <th>PRICE</th> <th>SAVE</th> </tr> </thead> <tbody> <tr> <td>\$770</td> <td>\$695</td> <td>\$75</td> </tr> <tr> <td>\$875</td> <td>\$695</td> <td>\$180</td> </tr> <tr> <td>\$950</td> <td>\$795</td> <td>\$150</td> </tr> <tr> <td>\$1,195</td> <td>\$990</td> <td>\$205</td> </tr> <tr> <td>\$1,895</td> <td>\$1,670</td> <td>\$225</td> </tr> <tr> <td>\$2,295</td> <td>\$1,995</td> <td>\$300</td> </tr> <tr> <td>\$3,100</td> <td>\$2,565</td> <td>\$535</td> </tr> </tbody> </table>	LIST	PRICE	SAVE	\$770	\$695	\$75	\$875	\$695	\$180	\$950	\$795	\$150	\$1,195	\$990	\$205	\$1,895	\$1,670	\$225	\$2,295	\$1,995	\$300	\$3,100	\$2,565	\$535	
LIST	PRICE	SAVE																								
\$770	\$695	\$75																								
\$875	\$695	\$180																								
\$950	\$795	\$150																								
\$1,195	\$990	\$205																								
\$1,895	\$1,670	\$225																								
\$2,295	\$1,995	\$300																								
\$3,100	\$2,565	\$535																								

ELENCO PRODUCTS AT DISCOUNT PRICES

<p>20MHz Dual Trace Oscilloscope</p> <p>MO-1251 \$359</p> <ul style="list-style-type: none"> 6" CRT Built in component tester TV Sync X-Y Operation <p>Top quality scopes at a very reasonable price. Contains all desired features. Two 1x, 10x probes, diagrams and manual. Two year guarantee.</p>	<p>FREE DMM with purchase of MO-1251/1252 Scope</p> <p>SCOPE PROBES</p> <p>P-1 65MHz, 1x, 10x \$19.95 P-2 100MHz, 1x, 10x \$23.95</p> <p>Fits all scopes with BNC connector</p>	<p>35MHz Dual Trace Good to 50MHz</p> <p>MO-1252 \$495</p> <ul style="list-style-type: none"> High luminance 6" CRT 1mV Sensitivity 6KV Acceleration Voltage 10ns Rise Time X-Y Operation - Z Axis Delayed Triggering Sweep 		
<p>Autorangeing DMM</p> <p>M-5000 \$45</p> <ul style="list-style-type: none"> 9 Functions Memory and Data hold 1/2% basic acc 3 1/2 digit LCD 	<p>True RMS 4 1/2 Digit Multimeter</p> <p>M-7000 \$135</p> <ul style="list-style-type: none"> .05% DC Accuracy .1% Resistance with Freq. Counter and deluxe case 	<p>Multimeter with Capacitance and Transistor Tester</p> <p>CM-1500 \$55</p> <p>Reads Volts, Ohms, Current, Capacitors, Transistors and Diodes with case</p>	<p>Digital Capacitance Meter</p> <p>CM-1550 \$58.95</p> <ul style="list-style-type: none"> 9 Ranges 1pf-20,000ufd .5% basic accy Zero control with case 	<p>Digital LCR Meter</p> <p>LC-1801 \$125</p> <p>Measures Coils 1uH-200H Caps. 1pf-200uf Res. 01-20M</p>
<p>AC Clamp-On Current Adapter</p> <p>ST-265 \$22</p> <p>0-1000A AC Works with most DMM</p>	<p>Bench DMMs</p> <p>M-3500 3 1/2 digit 1% accy \$125</p> <p>M-4500 4 1/2 digit 0.5% accy \$175</p>	<p>SOLDERING STATION TEMPERATURE CONTROLLED</p> <p>SL-30 \$135</p> <p>Digital display Temp range: 300F-900F Grounded tip Overheat prot</p>	<p>Solderless Breadboards</p> <p>9430 1,100 pins \$15 9434 2,170 pins \$25 9436 2,860 pins \$35 All have color coded posts</p> <p>9436 SHOWN</p>	<p>Low Cost Multimeter</p> <p>M-1600 \$25</p> <ul style="list-style-type: none"> 3 1/2 digit LCD 1% DC Accy 10A Scale Auto zero /polarity
<p>Wide Band Signal Generators</p> <p>SG-9000 \$129 RF Freq 100K-450MHz AM Modulation of 1KHz Variable RF output</p> <p>SG-9500 with Digital Display and 150MHz built-in Freq Ctr \$249</p>	<p>3 1/2 Digit Probe Type DMM</p> <p>M-1900 \$39</p> <p>Convenient one hand operation Measures DCV, ACV, Ohms Audible continuity check, Data hold</p>	<p>Function Generator</p> <p>Box #9600 \$28.95</p> <p>Provides sine, tri, squ wave From 1Hz to 1MHz AM or FM capability</p>	<p>Decade Box</p> <p>9610 or 9620 \$18.95</p> <p>#9610 Resistor Box 47 ohm to 1M & 100K pot #9620 Capacitor Box 47pf to 10MFD</p>	
<p>Digital Triple Power Supply</p> <p>XP-765 \$249</p> <p>0-20V at 1A 0-20V at 1A 5V at 5A</p> <p>Fully Regulated, Short circuit protected with 2 Limit Cont., 3 Separate supplies</p> <p>XP-669 with Analog Meters \$175</p>	<p>Quad Power Supply</p> <p>XP-580 \$59.95</p> <p>2-20V at 2A 12V at 1A 5V at 3A -5V at 5A</p> <p>Fully regulated and short circuit protected</p> <p>XP-575 without meters \$39.95</p>	<p>10MHz XT 100% IBM® Compatible</p> <p>5 Year Warranty</p> <p>\$595 MODEL PC-1000</p> <p>XP-575 without meters \$39.95</p>	<p>Four-Function Frequency Counters</p> <p>F-1000 1.26M \$259</p> <p>F-100 120MHz \$179</p> <p>Frequency, Period, Totalize, Self Check with High Stabilized Crystal Oven Oscillator, 8 digit LED display</p>	<p>GF-8016 Function Generator with Freq. Counter</p> <p>\$239</p> <p>Sine, Square, Triangle Pulse, Ramp, 2 to 2MHz Freq Counter, 1-10MHz</p> <p>GF-8015 without Freq. Meter \$179</p>
<p>WE WILL NOT BE UNDERSOLD! UPS Shipping: US 5% (\$10 Max) IL Res., 7% Tax</p>		<p>C & S SALES INC. 1245 Rosewood, Deerfield, IL 60015 (800) 292-7711 (312) 541-0710</p>		<p>15 Day Money Back Guarantee 2 Year Warranty WRITE FOR FREE CATALOG</p>

CIRCLE 11 ON FREE INFORMATION CARD

FREE!

New Catalog of Hard-To-Find Precision Tools

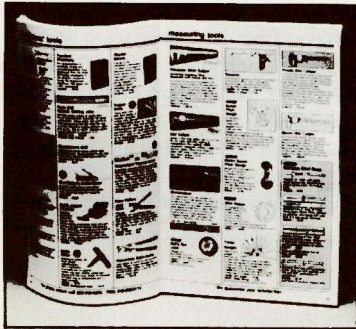

Jensen's new catalog is jam-packed with more than 2,000 quality items. Your single source for hard-to-find precision tools used by electronic technicians, scientists, engineers, schools, instrument mechanics, laboratories and government agencies. This popular catalog also contains Jensen's world-famous line of more than 40 tool kits. Call or write for your free copy today!

JENSEN 7815 S. 46th Street
TOOLS INC. Phoenix, AZ 85044
(602) 968-6231

CIRCLE 21 ON FREE INFORMATION CARD

ATTENTION! ELECTRONICS TECHNICIANS

EARN YOUR
**B.S.E.E.
DEGREE**

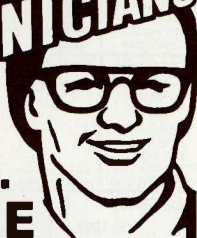

THROUGH HOME STUDY

Our New and Highly Effective Advanced-Placement Program for experienced Electronic Technicians grants credit for previous Schooling and Professional Experience, and can greatly reduce the time required to complete Program and reach graduation. No residence schooling required for qualified Electronic Technicians. Through this Special Program you can pull all of the loose ends of your electronics background together and earn your B.S.E.E. Degree. Upgrade your status and pay to the Engineering Level. Advance Rapidly! Many finish in 12 months or less. Students and graduates in all 50 States and throughout the World. Established Over 40 Years! Write for free Descriptive Literature.

COOK'S INSTITUTE
OF ELECTRONICS ENGINEERING



4251 CYPRESS DRIVE
JACKSON, MISSISSIPPI 39212

CIRCLE 20 ON FREE INFORMATION CARD

ELECTRONICS LIBRARY

(Continued from page 10)

connection, and presents helpful maintenance and troubleshooting tips. Information on such video devices as camcorders, video processors, stereo decoders, switchers, and remote controls is included. All the most common combinations of televisions, VCR's, and accessories are covered to help you get the most from the equipment you now own, and to adapt your video system when adding new components. *VCR Connections Guide: TV Accessory Hookup Made Easy* is available for \$8.95 from Howard W. Sams & Company, 4300 West 62nd St., Indianapolis, IN 46268; Tel. 800-428-SAMS.

CIRCLE 95 ON FREE INFORMATION CARD

AN INTRODUCTION TO LOUDSPEAKERS AND ENCLOSURE DESIGN

by V. Capel

A loudspeaker cabinet is much more than just a box to hold speakers. There are many types of enclosures and drive units, and

An Introduction to Loudspeakers and Enclosure Design

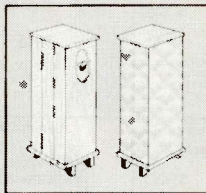

each has its own good points and drawbacks. This book explores those features and, in particular, examines what causes strengths and weaknesses in different enclosure designs. With an understanding of the principles involved, readers will be better able to make informed choices of loudspeaker design—or even design their own loudspeaker enclosures.

The book describes the moving-coil driver in detail, as well as alternative drivers. Cross-over units are discussed, including the various types, how they work, the distortions they produce, and how to avoid them.

There are also step-by-step instructions on how to build a *Kapellmeister* loudspeaker enclosure. That design involves unique features that overcome many of the disadvantages of more conventional speakers. The *Kapellmeister* is a transmission-line speaker that offers remarkable stereo imaging and an uncolored musical sound. It takes up

minimal floor space, and is inexpensive to build.

An Introduction to Loudspeakers and Enclosure Design (Order No. BP256) is available for \$7.95, including shipping, from *Electronics Technology Today*, P.O. Box 240, Massapequa, NY 11762.

CIRCLE 97 ON FREE INFORMATION CARD

50 CMOS IC PROJECTS

by Delton T. Horn

Written for the intermediate experimenter or hobbyist, this book provides practical projects designed to use CMOS IC's (complementary metal-oxide semiconductor integrated circuits). CMOS IC's are popular because they can function within a wide range of voltages, are inexpensive, and are readily available on the hobbyist market. In this book, Delton T. Horn prefaces the projects with a broad introduction to digital electronics and CMOS IC's.

The projects are all designed to be constructed in one or two evenings. Full sche-



matics, including working diagrams and parts lists are provided, and construction hints and project variations are offered. A sampling of the projects includes time-keeping circuits, music-making projects, binary circuits, LED flashers, test equipment, control circuits, signal-generator projects, and game circuits.

50 CMOS IC Projects is available for \$16.95 from *Tab Books Inc.*, Blue Ridge Summit, PA 17294-0850; Tel. 1-800-233-1128.

CIRCLE 98 ON FREE INFORMATION CARD

UNDERSTANDING LASERS

by Jeff Hecht

Non-technical types in particular tend to think of lasers in terms of flashy sci-fi devices and special effects in films. In reality, lasers have become commonplace in many fields—invisibly enhancing our everyday lives in CD-players, telephones, supermarket checkout lanes, and doctors' offices.

This book explores those real-life laser
(Continued on page 164)

1989
**ELECTRONICS
HOBBYISTS
handbook™**

By the Editors of
POPULAR ELECTRONICS®

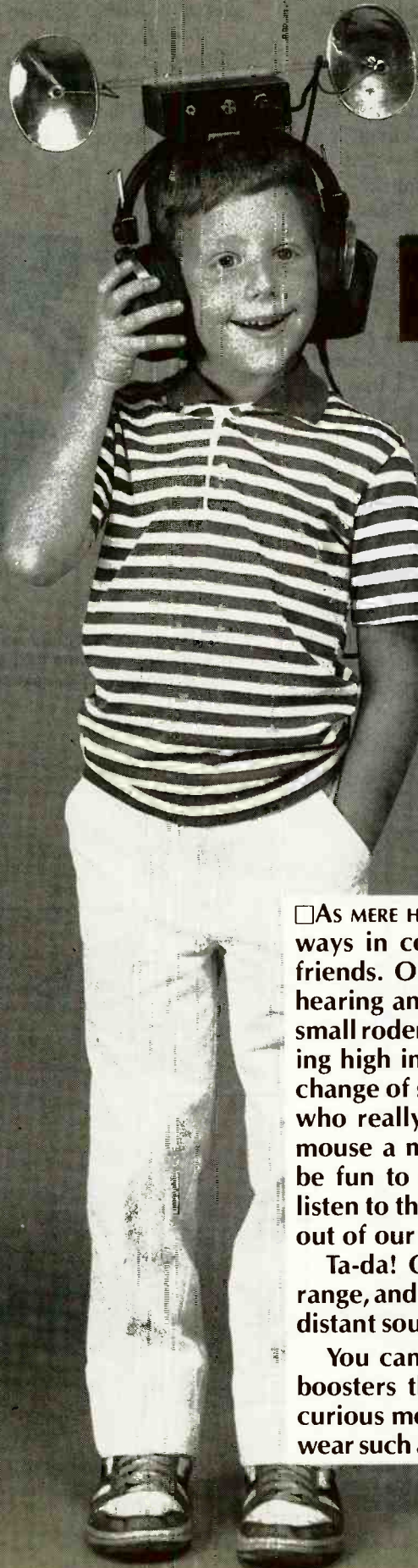

BIONIC EARS

**When all is said and done
you'll catch every word with
this device that would put
a Doberman's sense
of hearing to shame!**

By Charles D. Rakes

AS MERE HOMO SAPIENS OUR SENSES ARE LIMITED IN MANY ways in comparison to our furred and feathered friends. Our canine pals can out do our sense of hearing and smell, and our national bird can see a small rodent scurrying across a meadow, while soaring high in the sky. No, I'm not advocating an exchange of senses with any of our gifted friends, and who really wants to sniff like Benji, or observe a mouse a mile away? Certainly not I, but it would be fun to enhance our hearing ability so we can listen to those weak and distant sounds that are just out of our normal hearing range.

Ta-da! Our bionic ears can extend our hearing range, and ability to determine the direction of those distant sounds that were only faint whispers before.

You can build a pair of electronic bionic audio boosters that can thrill and excite the brave and curious members of your family who are willing to wear such a marvelous piece of high-tech equipment.

How Does it Work?

A pair of precision solar reflectors, with mini electret-mike elements located at their focal points, collect the sound and feed their minute signals to U1 to be amplified. The two ears are separated by a distance of about 8-inches to create a stereophonic effect and are supported by the amplifier's cabinet and stereo earphones.

Here's how the circuit works: Take a gander at the schematic diagram in Fig. 1, and you'll see that the circuit is a straight-forward, dual audio amplifier designed to drive a pair of low-impedance stereo phones. Both amplifiers are identical in design using the same component values, and share a dual gain-control potentiometer, R15/R16.

Electret mike, MIC1, is supplied an operating current through R5, and the audio is coupled to the input of U1-a through C3 and R9. The gain of that stage is set by the ratio of R9 and R11, or 220K/1K, giving a voltage gain of 220. The input of the second amplifier, U1-b, is connected to the wiper of the gain control potentiometer, R15, through coupling capacitor C8 and input resistor R7. The gain of the second stage is 220 also. Theoretically the accumulated gain of both amplifier stages together, with the gain wide open, is near 50K.

The audio output of U1-b is coupled through C5 to the primary winding of a mini audio-output transformer, T1, with its secondary driving one earphone through J3. Resistors R3 and R4 set the bias of the positive inputs of the four op-amps to about 1/2 of the supply voltage. That biasing arrangement allows each amplifier to obtain an equal positive and negative output swing. The mirror amplifier circuit of U1-c and U1-d operates in the same manner, as the described amplifier, to drive the other earphone.

Building Your Own

A good place to commence is to build up the two sound-reflector mikes. Refer to the photos and the drawing in Fig. 2. Two Radio Shack solar cigarette lighters are modified to reflect sound by mounting the electret elements at the focal point. A brass pipe fitting with an inside diameter slightly larger than the mike's diameter is used to house each of the mike elements. A .062-in. diameter, brass rod is cut and

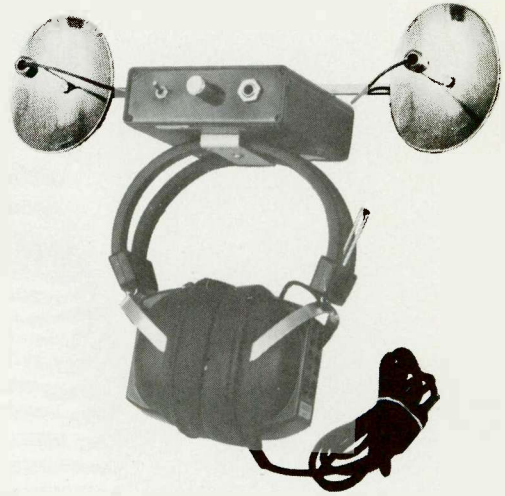

The Bionic Ears require no external amplification. The unit is self-contained and fully portable. Just the thing for the super snooper. (The next company picnic should be revealing!)

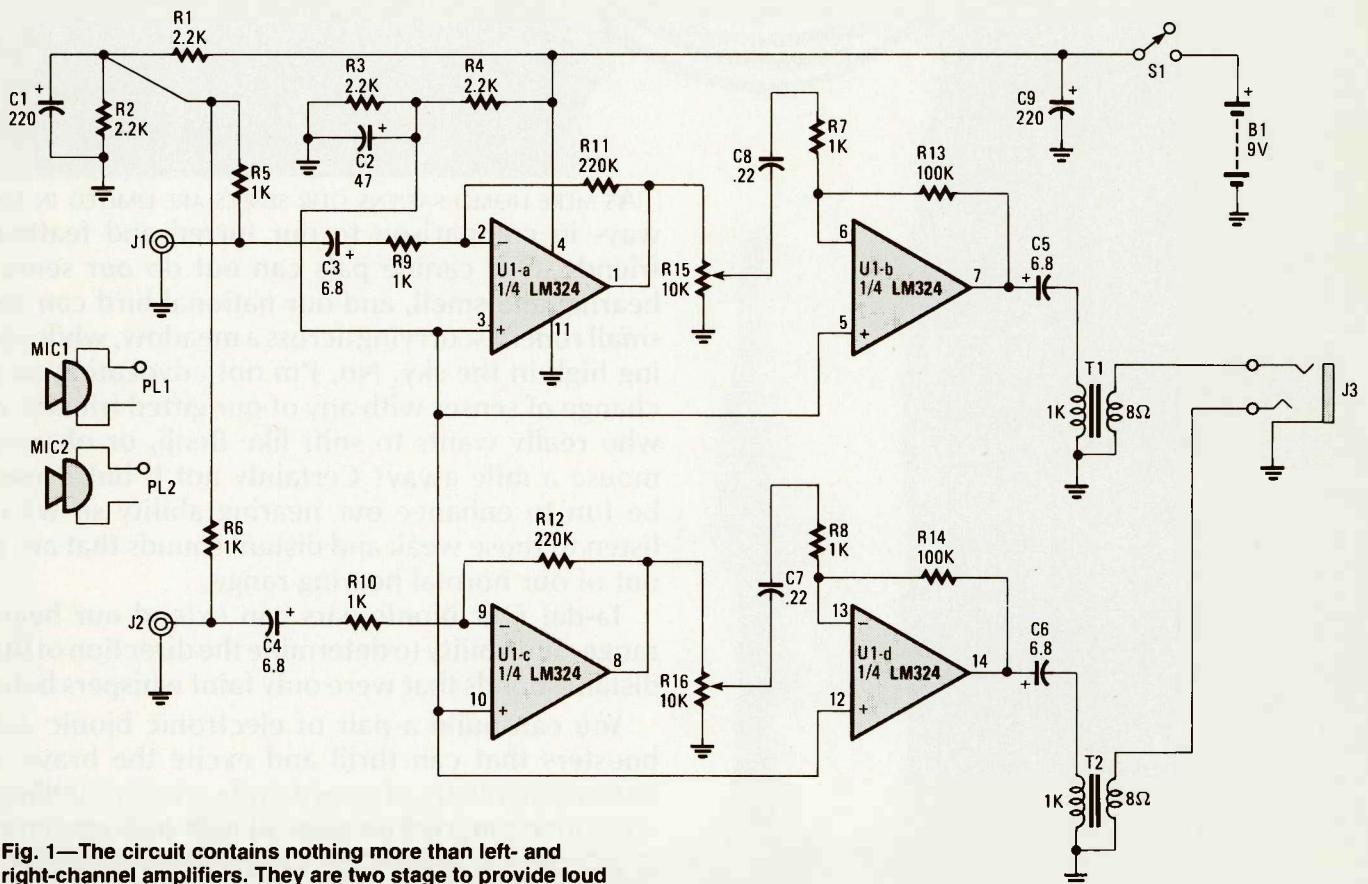

Fig. 1—The circuit contains nothing more than left- and right-channel amplifiers. They are two stage to provide loud output without forcing too much gain from each op-amp.

shaped to hold the pipe fitting in the center of the reflector and at the focal point. The rod is soldered to the fitting and kept in place on the reflector with a 6-32 screw and a 1/2-in. metal spacer (see Fig. 2). A 12-in. length of 1/4-in. square, brass tubing connects the ears together and to the amplifier's cabinet.

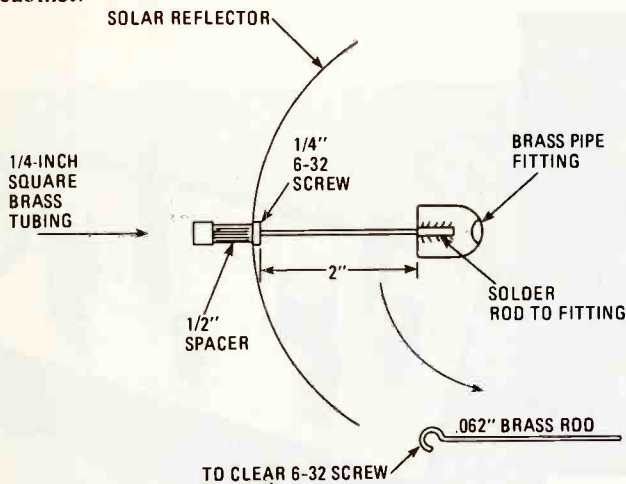
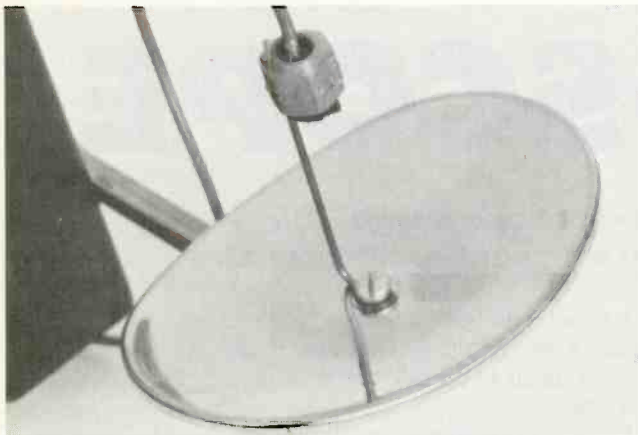
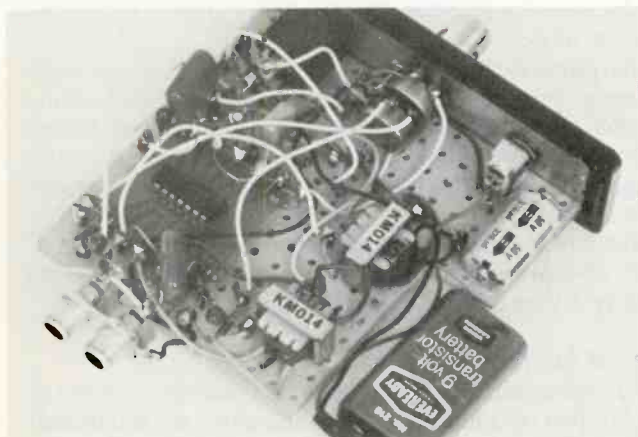

Fig. 2—Proper positioning of the microphones is important. Be sure that the mic's are not only centered, but at the focal point of the parabolic dishes as well.



The mikes pickup will be enhanced by proper placement at the parabolic-reflector's focal point. If you haven't got an iron hot enough to solder the rod to the outside of the fitting carefully, then try placing the rod inside the fitting and squeezing the mike into place instead.



With creative placement, the unit can be fitted in a reasonably small cabinet. The authors model was fitted with phono jacks to facilitate its use as a stereo preamp.

PARTS LIST FOR THE BIONIC EARS

CAPACITORS

C1, C9—220- μ F, 16-WVDC electrolytic
 C2—47- μ F, 16-WVDC electrolytic
 C3-C6—6.8- μ F, 35-WVDC, tantalum electrolytic
 C7, C8—.22- μ F, 100-WVDC, mylar

RESISTORS

(All resistors are 1/4-watt 5% units unless noted otherwise.)

R1-R4—2200-ohm
 R5-R10—1000-ohm
 R11, R12—220,000-ohm
 R13, R14—100,000-ohm
 R15/R16—10,000-ohm, dual, mini potentiometer

ADDITIONAL PARTS AND MATERIALS

B1—9-volt, transistor-radio battery
 U1—LM324 quad-op-amp.
 J1, J2—RCA phono jack
 J3—Stereo 1/4-in. jack
 M1, M2—Electret mike element,
 Radio Shack #270-090
 P1, P2—RCA phono plug
 S1—SPST mini toggle switch
 T1, T2—1000-ohm to 8-ohm mini, audio-output transformer

Aluminum utility case 1-9/16 \times 4-3/4-in., (2) Solar cigarette lighters Radio Shack #61-2797, (2) small brass pipe fittings, IC socket, perfboard hardware, stereo headphones etc.

Approximately 11 inches of small, shielded, audio cable connects each mike element to an RCA phono plug. Use just enough electrical tape wrapped around the mike element to keep it snugly in place inside the fitting, and take care not to short the positive mike lead to the fitting.

The headphones can be mounted to the bottom of the amplifier's cabinet with a metal or plastic bracket or bolted directly in place with 6-32 hardware. Actually any workable construction scheme, as long as the ears are constructed to pick up the reflected sound, can be used in the physical layout of the project. Build to suit.

Wiring up the circuit. A 3-3/4 \times 4 inch piece of perf board, with a small section cut out to allow a nine volt battery to fit in place hold the amplifier's components. The general component layout shown in the photo can be followed, or a PC board could be made, but in any case the layout isn't critical, so if a good approach is taken no problems should occur.

The perfboard is mounted to the front panel with a "L" bracket made from a scrap piece of aluminum, and a similar small bracket holds the two mike input jacks, J1 and J2 on the rear. Drill or punch matching holes in the back panel of the cabinet to allow the two input jacks to stick through about 1/4-in.

Trying Out the Ears

Install a nine-volt battery in place and slide the circuit into the cabinet and turn on the power. Surrounding sounds should be loud and clear in both earphones. Adjust the gain to match the application and check out the ears for gain balance and overall directivity. If one channel seems to be more sensitive than the other check to see that both mikes are set at their focal point.

The only problem with the bionic ears is in convincing someone over the age of seven to pose for a picture, and I just can't see why anyone would mind, can you? ■

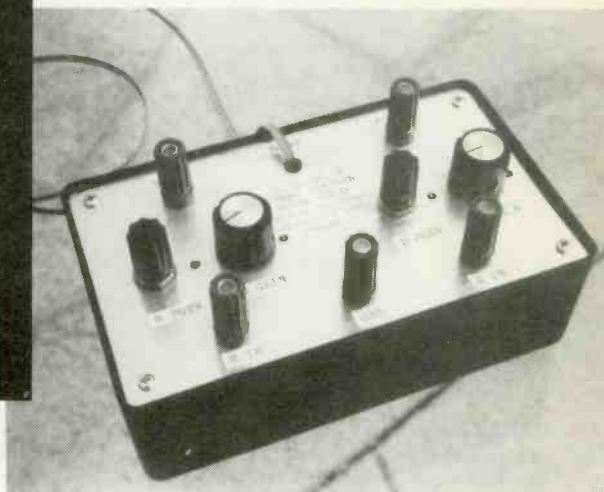
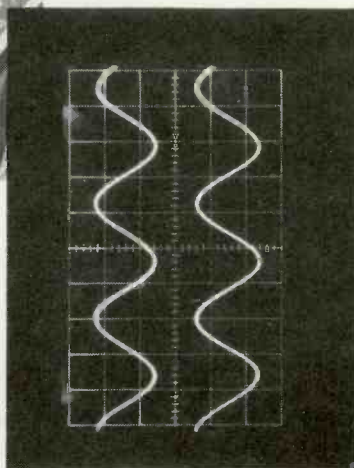

3D

By Homer Tilton

OSCILLOSCOPE

There is no point in using two eyes to look at one image. This project lets you enter the third dimension with your oscilloscope!

THE MAIN REASON WE SEE IN 3-D IS BECAUSE WE ARE stereoscopic—we have two eyes with slightly different perspectives. If we display two slightly different oscilloscope images in front of our eyes simultaneously, we can simulate the feeling of stereoscopic vision. Starting with a dual-trace oscilloscope, a pair of simple lenses, a dual 15-volt power supply, and a handful of ordinary electronic components, you can complete this project in two evenings and be viewing stereoscopic images the next day.

The project makes use of three waveforms. In ordinary two-dimensional oscillography, two waveforms are used—one to produce horizontal deflection, the other to produce vertical deflection. That is true whether the scope is used in sweep mode (with an internal time base), or XY mode (using an external horizontal sweep). For example, a circle or ellipse can be produced by using two sinusoids in quadrature as the two deflection inputs.

In three-dimensional oscillography, that circle or ellipse can be stretched into a helix (a coil-spring shaped curve) by injecting a sawtooth waveform to act as a third deflection axis.

System Description

The stereo-oscilloscope consists of three major assemblies: a dual-trace oscilloscope, a stereo adapter, and a stereo viewer. This article gives construction details for the latter two assemblies.

Note that the oscilloscope is shown standing on end. That is required because the scope's two vertical channels become

the left and right horizontal axes; and the scope's horizontal channel becomes the vertical axis in this application. The observer stands to the side of the scope and looks down into the viewer.

Virtually any dualtrace oscilloscope is suitable. It will be used in an XY mode (as well as in a sweep mode), and so it should have good bandwidth all around, and relatively small phase shifts between channels—on the order of three degrees maximum. The author used a Heathkit model IO-4510. (This model is no longer offered by Heathkit, but they have other suitable models, for example the IO-4225.)

The stereo viewer consists of two positive lenses and some ordinary construction materials such as posterboard. Some suitable grade 2 lenses with 50-mm focal length and 27-mm diameter, are available from Edmund Scientific (order number 32176) for \$4.75 each. To contact them phone 609/573-6250.

The lenses could also be obtained from two small, hand-held, 35-mm slide viewers. Focal length should be approximately 2-1/2 to 3 inches. (More on focal length later.)

Stereo Adapter

The schematic diagram for the stereo adapter is shown in Fig. 1. Two op-amps are used as summing and differential amplifiers. Amplifier U1 produces the right output (R OUT), which will produce horizontal deflection for the right-eye view. Amplifier U2 produces the left output (L OUT) which will produce horizontal deflection for the left-eye view.

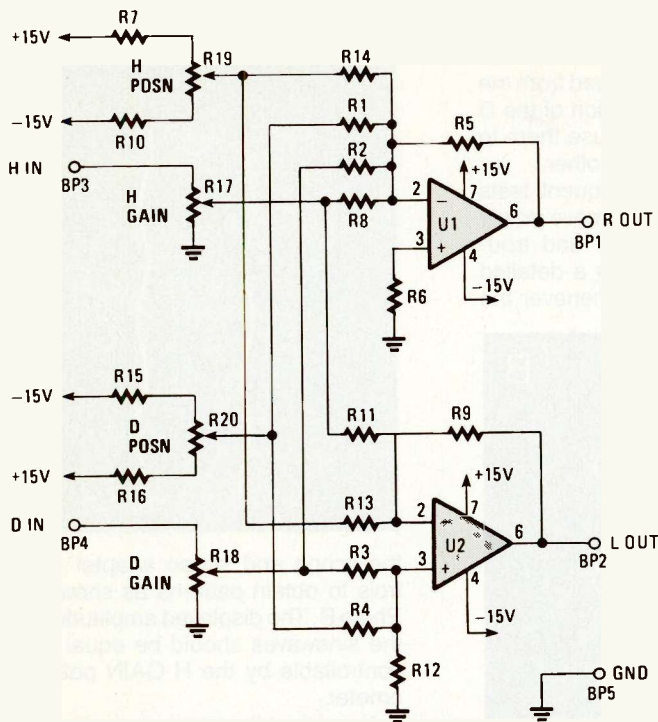

Fig. 1—The power supply for the stereo adapter is not shown. The circuit can make use of a standard dual supply.

The waveforms for the horizontal (H) and depth (D) inputs are added in U1, and so produce deflection in the same direction in the right image.

DC "signals" from position (POSN) potentiometers are likewise added in U1 and subtracted in U2. Thus, the H POSN control causes the left and right images to move in the same direction; whereas the D POSN control causes them to move oppositely to each other, thus, producing the effect of an "in-out" motion when viewed stereoscopically. In order for this method of CRT beam positioning to work, the oscilloscope's deflection-channel amplifiers must be DC coupled all the way from the input jacks to the CRT deflection plates. Nearly all modern oscilloscopes have that feature.

Notice that the amplifiers are DC coupled, so waveforms containing large DC components must not be used as inputs without the use of series DC-blocking capacitors. In any

PARTS LIST FOR THE STEREO ADAPTER

BP1-BP4—Red binding post
 BP5—Black binding post
 (All fixed resistors are ¼-watt, 10% units.)
 R1-R4—100,000-ohm
 R5-R16—10000-ohm
 R17, R18—10000-ohm, ½-watt, linear-taper potentiometer
 R19, R20—5000-ohm, ½-watt, linear-taper potentiometer
 U1, U2—741 operational-amplifier integrated circuits
 Printed circuit board (Radio Shack 276-170 or equivalent), #22 insulated hookup wire, cabinet (Radio Shack 270-627 or equivalent), grounding lug for the cover, 4 knobs for R17-R20, powercord grommet, powercord, solder, etc.

event, inputs should not exceed +15 volts, as larger voltages could damage the op-amps. Frequencies from DC to about 100 kHz are suitable as inputs.

Adapter Construction

All parts were mounted in a Radio Shack #270-627 case on a Protoboard, although another case certainly would be suitable. A panel drilling pattern is shown in Fig. 2.

Once you have obtained the parts listed in the Parts List, construction can begin. Start by inserting and soldering component leads in the PC board, according to the pattern shown in Fig. 3. Using IC sockets for the op-amps (U1 and U2) is optional. The author did not use any.

Take your time because mistakes are easier to make than to find and correct later. Recheck your work frequently along the way. Be sure to add wire jumpers where indicated, just as if they were another component. When the PC board is wired and soldered, give it a final inspection. Then remove solder flux with an old toothbrush dipped in alcohol; but scrub gently! Now set the PC board aside in a safe place.

Redraw the front-panel drilling pattern full size on a piece of paper, using Fig. 2 as a guide, then cut it out along the panel outline. Check the locations of the B-size holes to be sure they are correct for keying the particular potentiometers you plan to use.

Tape the front-panel pattern to the front panel and punch

Fig. 2—All dimensions for the adapter's face plate are in inches. Note that the binding-post holes are out of round. That is to accommodate the posts peculiar shape. The holes can be created by drilling with a ¼-in. bit and a round file.

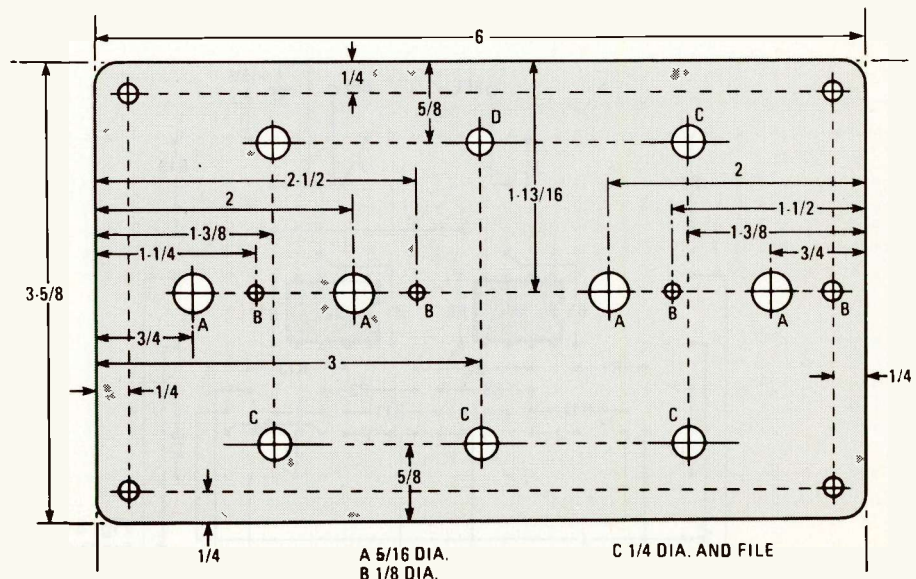

The Stereo Adapter Set-up and Test Procedure

When construction has been completed, you are ready to set up and check out your stereo-oscilloscope.

Position the oscilloscope on-end on the table top where it will be used. Power it up and set the controls for dual-trace use. Obtain two sweep baselines: Position them so they straddle the CRT's horizontal centerline equally as shown in Photo A. Set the scope gain controls for the two channels to the same sensitivity (about 1 V/cm) and do not change them.

Power-up the stereo adapter and check the operation of the two position (POSN) controls. Rotation of the H POSN control should cause the two traces to move in the same direc-

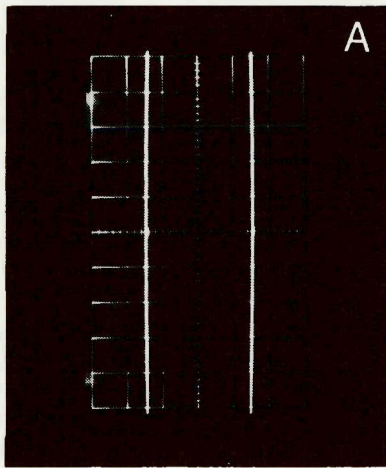

tion. (Side-to-side as viewed from the side of the scope.) Rotation of the D POSN control should cause them to move oppositely to each other.

If these or any subsequent tests have negative results, remove power from the stereo adapter and troubleshoot it—starting with a detailed visual inspection (i.e., whenever the

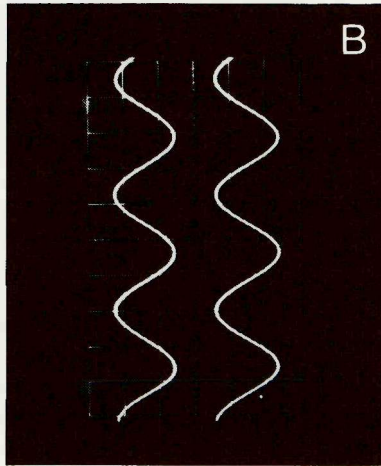

oscilloscope is used in the stereo mode).

For the next test inject a sinewave at the H IN binding post and check to see that displays of identical sinewaves can be obtained on the two traces of the scope. (Don't forget to connect your sinewave generator ground to the system ground!) Adjust

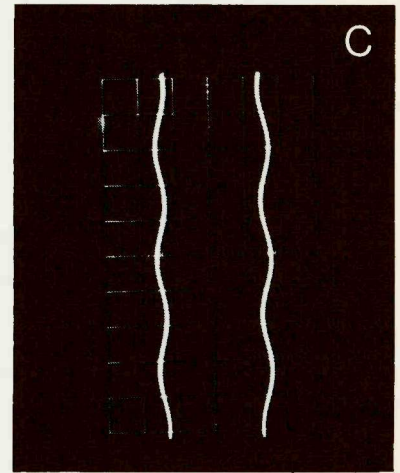

the scope and stereo adapter controls to obtain patterns as shown in Photo B. The displayed amplitudes of the sinewaves should be equal and controllable by the H GAIN potentiometer.

Now inject the same sinewave into the D IN binding post instead. Reduced-amplitude sinewaves should appear on the two scope traces, and they should be 180 degrees out of phase with each other. Their amplitudes should be equal and controlled by the D GAIN potentiometer (see Photo C).

When the above tests have been satisfactorily completed you are ready to begin viewing stereo images using the stereo viewer. ■

the centers of the holes to be drilled. Remove the pattern and drill the holes. Oblong holes for the binding posts should be drilled undersize, then filed to their final shape to properly accommodate the binding posts.

Install the panel components, and wire them first to one another, and then to the board according to Fig. 3.

Carefully solder all connections and inspect your work,

looking for possible errors. (You know the routine!)

Gently fold the wires to the PC board so that the PC board is lying parallel to the front panel in such a way that the assembly will fit into the case. Label the front panel following Fig. 8, using your favorite method. (The author simply typed on sticky-backed paper, covered this with transparent tape to prevent smudging, cut out the legends, and stuck them in

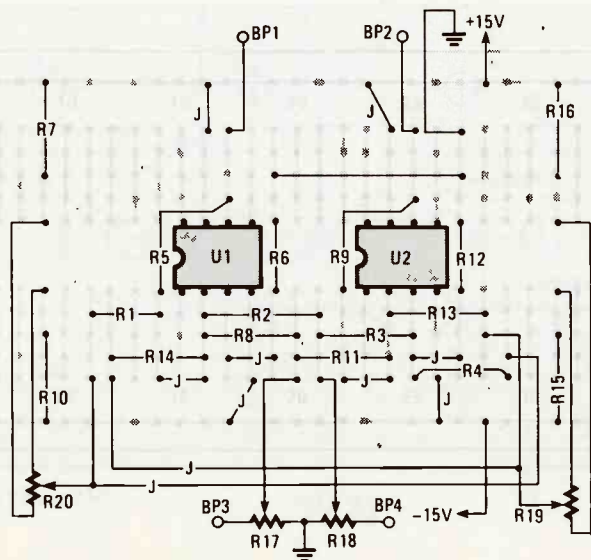
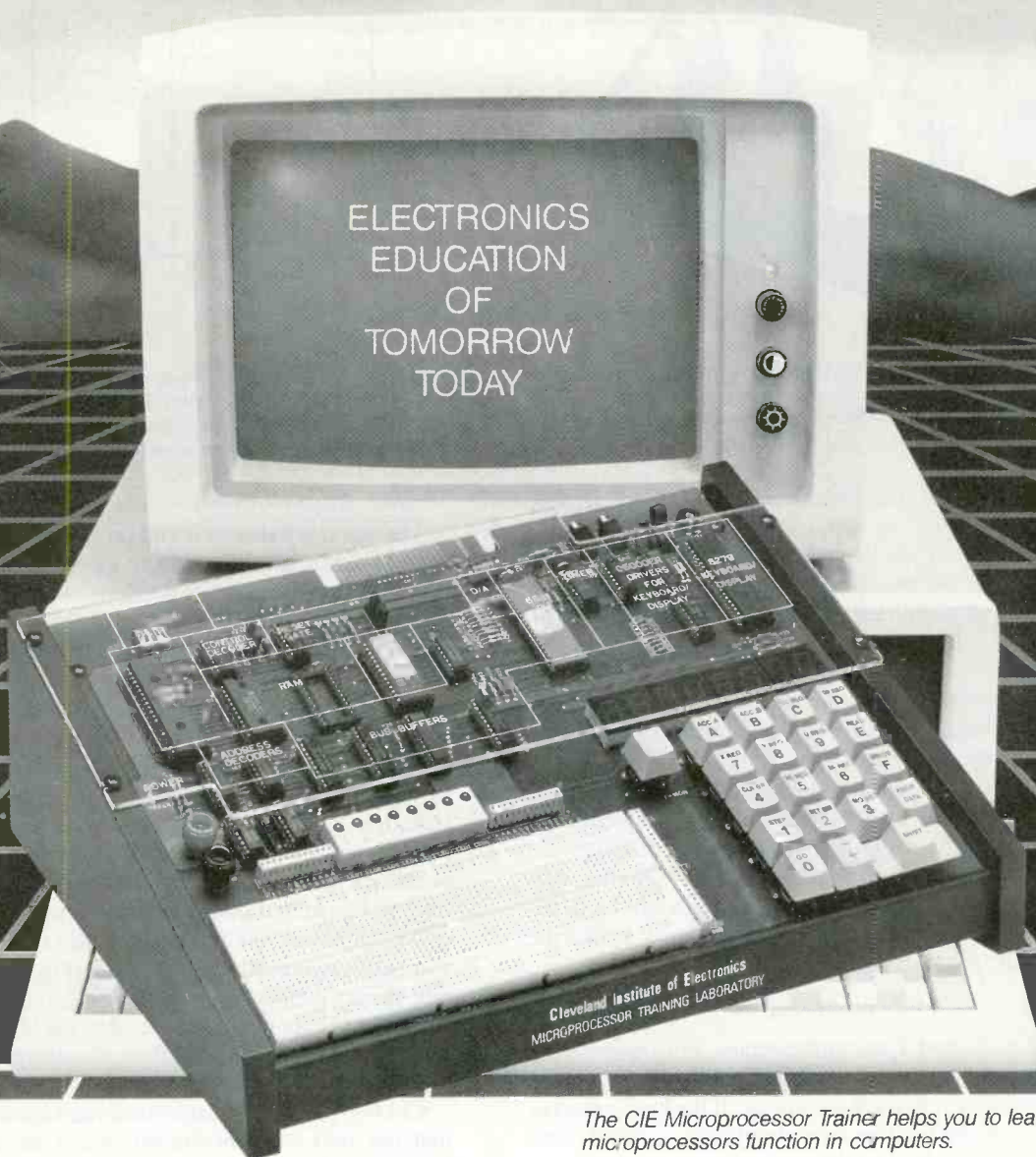

Fig. 3—The circuit board has plenty of room left over for the placement of add-on parts such as input and output buffer stages, or perhaps a simple function generator.

EXPAND YOUR CAREER HORIZONS...



The CIE Microprocessor Trainer helps you to learn how circuits with microprocessors function in computers.

START WITH CIE.

Microprocessor Technology. Satellite Communications. Robotics. Wherever you want to go in electronics... start first with CIE.

Why CIE? Because we're the leader in teaching electronics through independent study. Consider this. We teach over 25,000 students from all over the United States and in over 70 foreign countries. And we've been doing it for over 50 years, helping thousands of men and women get started in electronics careers.

We offer flexible training to meet your needs. You can start at the beginner level or, if you already know something about electronics, you may want to start at a higher level. But wherever you start, you can go as far as you like. You can even earn your Associate in Applied Science Degree in Electronics.

Let us get you started today. Just call toll-free 1-800-321-2155 (in Ohio, 1-800-362-2105) or mail in

CIRCLE 10 ON FREE INFORMATION CARD

the handy reply coupon or card below to:
Cleveland Institute of Electronics,
1776 East 17th Street, Cleveland, Ohio 44114.

CIE World Headquarters

AH01

Cleveland Institute of Electronics, Inc.
1776 East 17th Street • Cleveland, Ohio 44114

Please send your independent study catalog.
For your convenience, CIE will try to have a representative contact you — there is no obligation.

Print Name _____

Address _____ Apt. _____

City _____ State _____ Zip _____

Age _____ Area Code/Phone No. _____

Check box for G.I. Bill bulletin on Educational Benefits

Veteran Active Duty **MAIL TODAY!**

Just call toll-free 1-800-321-2155 (in Ohio, 1-800-362-2105)

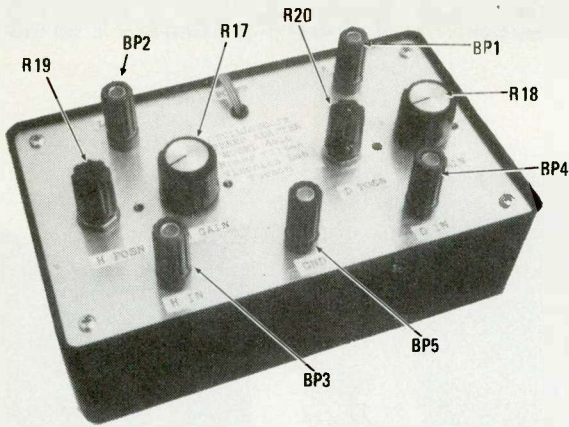

The panel layout shown here is not a must for proper functioning of the circuit however, its symmetry will provide ease of use. The user can become familiar with the controls and binding posts quickly in an intuitive fashion.

place on the panel. That method is quick, neat, and the results are attractive.

Put the assembly in its case and fasten the front panel to the case using the four screws provided with the case. The stereo adapter is now complete. Set it aside—again in a safe place!

Stereo Viewer

Before beginning construction on the stereo viewer, you must lay out a diagram similar to that shown in Fig. 4. The dimensions in the diagram depend on your components. Dimension f is the focal length of the two lenses (both lenses must be identical). One method of finding the focal length, f , of a simple positive (converging) lens is to use a *near-source*. The lens is used to focus the image of a ceiling light (the near-source) onto a table top, then the focal length can be determined by measuring of the light-to-lens distance, p , and the lens-to-table distance, q . Then use the formula:

$$f = pq / (p + q)$$

The units of p , q , and f are unimportant, but must be the same. If they are inches, then f will also be inches.

A second method is to use a far-source. If the lens is used to focus an image of the sun (the far-source) onto a surface, then the distance from the lens to the surface is f .

Dimension S is one-half the useful screen height, but not to exceed 2-1/2 inches. (This becomes one-half the useful screen width in this application.) The purpose of the diagram is to determine dimension A . Once dimension A has been determined, the patterns in Fig. 5 can be laid out.

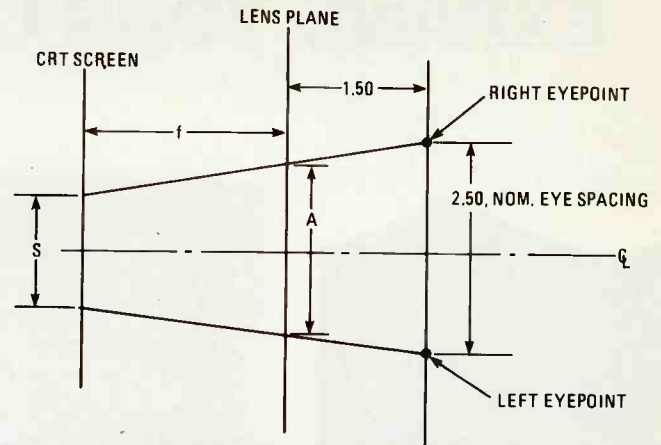
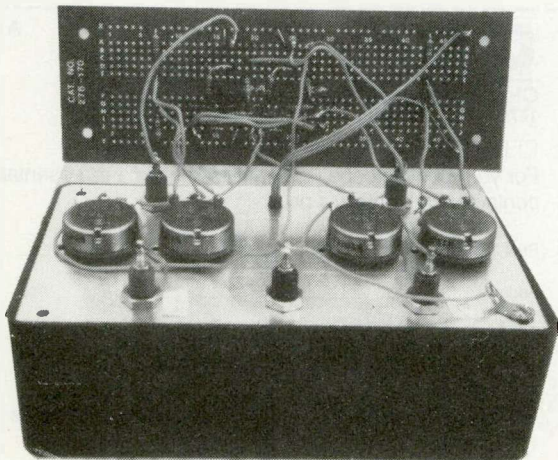

Fig. 4—If you are not going to buy the standard lenses mentioned in the text you will have to first find the lenses focal length (as per the text), and then use this drawing to determine the viewers A and F dimensions.

Viewer Construction

Lay out two patterns A and one pattern B on heavy posterboard according to Fig. 5. The diameters of the two holes in each pattern depend on the lens' diameter. Diameter $D2$ should be just slightly larger than the lens diameter and $D1$ should be smaller than the lens diameter, so that when a sandwich is made from the three patterns with the lenses in place, the lenses will be retained.

Now lay out the shroud full scale. Half the shroud is shown in Fig. 6; the other half is its mirror image. Transfer this pattern to a piece of heavy acetate or similar stock. (Suitable material can be obtained from a plastic two-liter soft-drink container.) If the material you have used is transparent, it will have to be painted (later) to make it opaque.

Assemble the lens holder and lenses from the three patterns you cut from posterboard following Fig. 7. You may wish to tape them together as the author did, so that the lenses could be salvaged later without destroying the lens holder. If you've no future designs on them, then glue them, being careful not to contaminate the lenses.

Cut two pieces of quarter-inch hard balsa wood or similar material into crescent-shaped pieces as shown in Fig. 7. Dimension B depends on your oscilloscope, and should be such that the two legs (when they are attached) will straddle the CRT bezel from top to bottom. Glue the two pieces of balsa wood in place.

Next, cut two legs of posterboard to support the stereo viewer above the CRT screen at the proper distance; the "proper distance" being such that the distance from the CRT phosphor screen to the lenses is equal to the lens focal length, f . The other dimension of the legs should be approximately 2-1/2 inches. Glue these two legs to the stereo viewer as shown.

After all the glued joints are dry and firm, wrap the shroud around the lens holder and attach to the two balsa wood pieces using four small wood screws. Drill holes for the screws so as not to split the balsa wood.

A final touch is to spray the stereo viewer with flat black paint. Be sure to adequately protect both sides of the two lenses during this operation. Finally, a strip of felt can be glued around the exposed edge of the shroud if desired.

Notice the special grounding lug connecting the ground binding post (BP5) to the panel faceplate. Although it is not an absolute necessity, it is wise to install it.

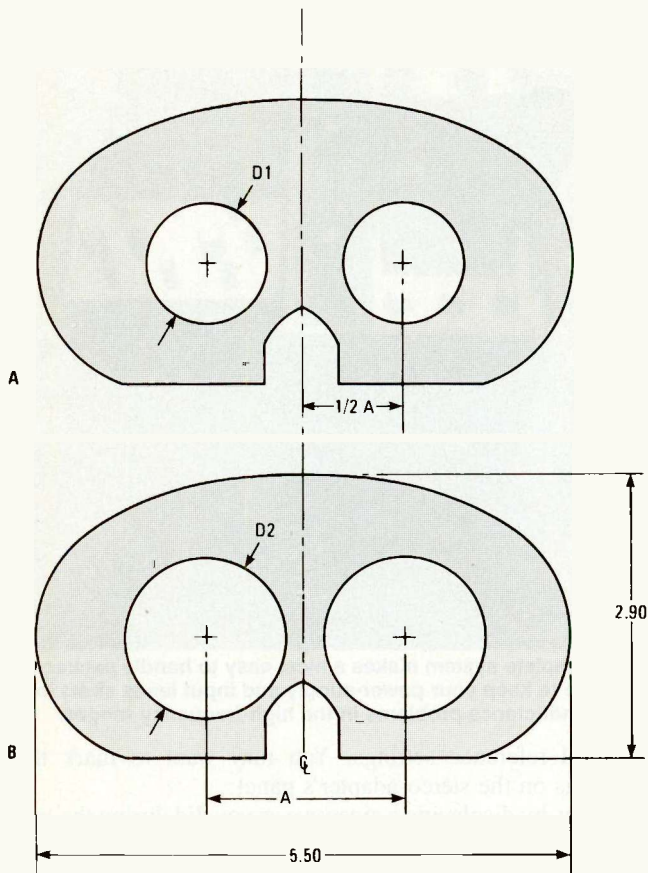
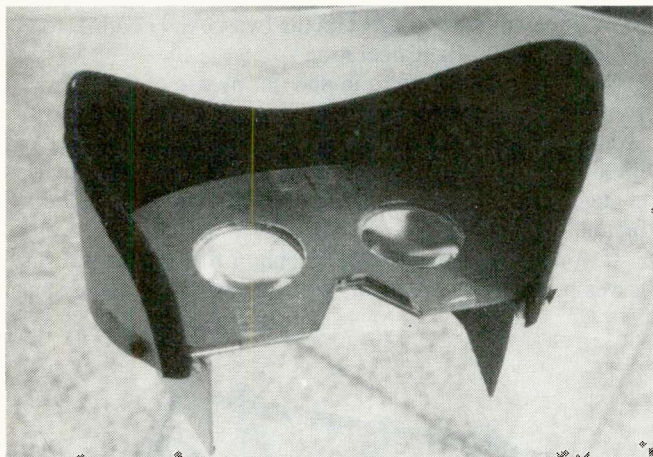

Fig. 5—You will have to experiment with the size of the nose bridge. Be sure to leave enough clearance for the placement of felt material for comfort.



Taping the viewer together may be preferred over gluing it if you will use the lenses for something else in the future.

This completes the stereo viewer and you are ready to connect the system together as in Fig. 8 and follow the procedure outlined in the set-up section.

Viewing the Images

Position the stereo viewer atop the oscilloscope in the position shown in the photos. Start with no inputs to the stereo adapter (or turn its two GAIN controls all the way counter-clockwise). Two baseline traces should be present as in the setup procedure.

View the traces by placing your head against the stereo

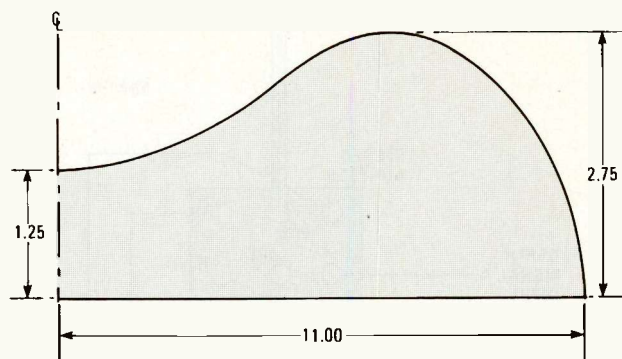

Fig. 6—The shroud material should be flexible for easy shaping (a plastic soda bottle is recommended as long as the sharp edges are covered with felt or a similar material. Note that this drawing is not scaled or proportional.

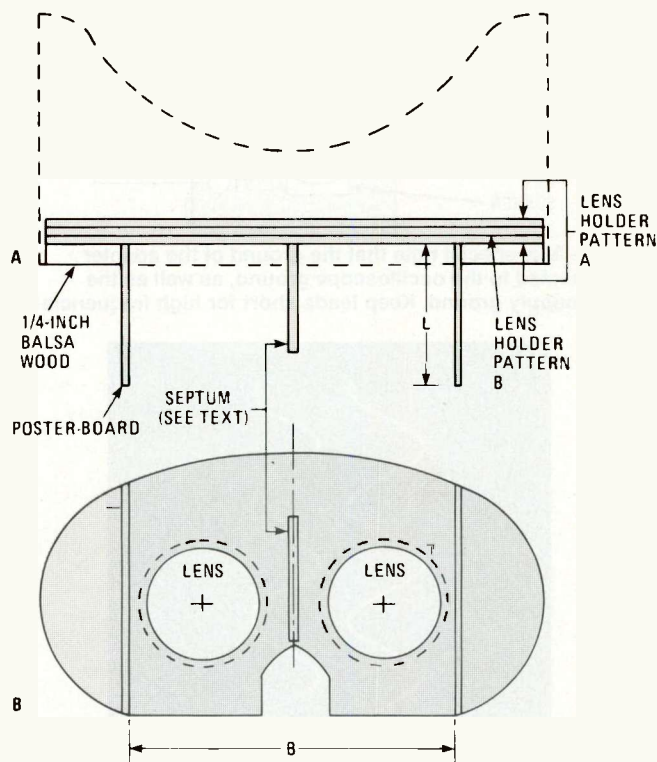

Fig. 7—When making the poster-board legs, be sure to subtract the thickness of the balsa wood from the focal length to arrive at L. That will optimize the accuracy of the lens placement for a crisp focus on the CRT.

viewer. Rock the H POSN and D POSN controls slightly until fusion occurs. Fusion means the two images are seen as one; with one image being viewed by the right eye only, and the other by the left eye only. If obtaining fusion is difficult, relax your vision by imagining you are looking at a far-away mountain top. Blink normally, do not stare, and give yourself time. When fusion occurs, you will see the image "lock in" and remain rock steady. (With practice you will find it easier and easier to obtain fusion.)

As a further check to see if fusion has occurred, slowly rock the D POSN control through a very small arc. The traces (which you now see as a single, fused trace) should appear to move toward and away from you.

Experiment with the two POSN controls to find the settings which produce fusion best. Those will be your POSN-

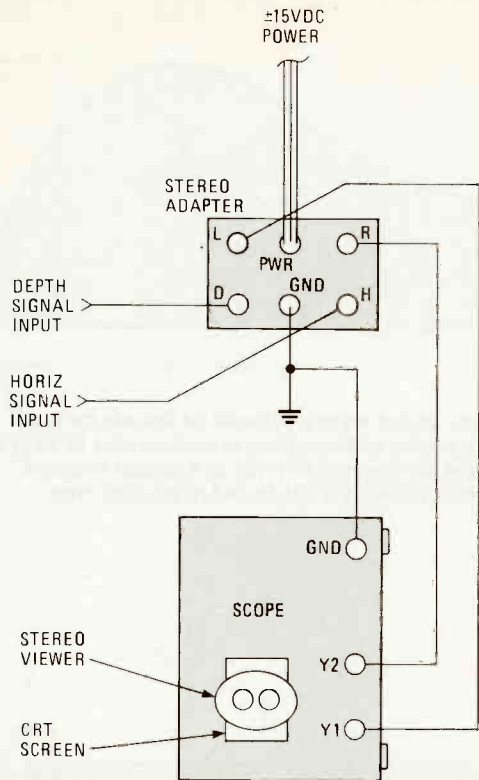
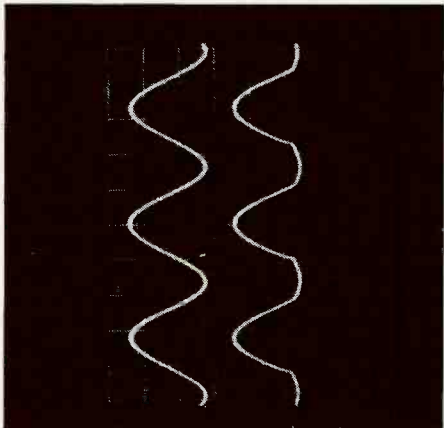

Fig. 8—Take special note that the ground of the adapter is connected to the oscilloscope ground, as well as the power-supply ground. Keep leads short for high frequencies.



This bent sinewave is produced as a result of the voltage vs. current vs. time characteristic curve for a diode.



The center of each lens should be directly over its corresponding flat trace at zero volts. The viewer can be moved over any portion of the wave forms in the X direction.

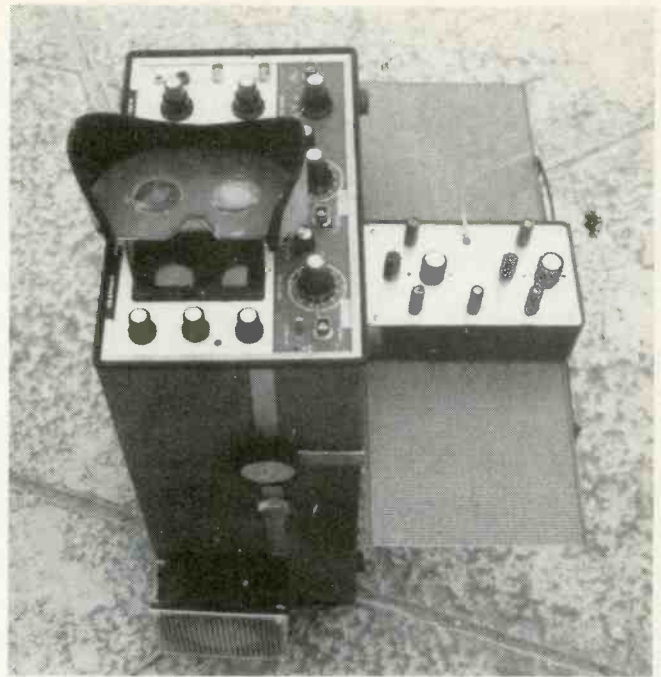

The complete system makes a nice, easy to handle package. Be sure to keep your power-supply and input leads short to avoid inductance problems in the high-frequency ranges.

control reference settings. You may want to mark those settings on the stereo-adapter's panel.

Now, by displaying a sinewave as you did during the initial set-up phase, you should see a single, fused sinewave. It will be on a frontal plane if the sinewave generator is connected to the H input (frontal planes are planes parallel to the CRT screen); or it will be on a vertical saggital plane (an "in and out" plane) if it is connected to the D input. If you connect it to both inputs, then it will appear on an inclined plane. Slowly rock the two POSN and the two GAIN controls to get a further feel for their operation.

When moving a pattern in and out by use of the D POSN control, its size will appear to change. This is due to the absence of linear perspective, another depth cue almost as important as stereo in some applications. If this apparent change in size does not occur, then you have not obtained fusion.

If you have not been able to obtain fusion and see sine-waves in stereo at this point, go back and retrace your steps;

(Continued on page 158)



Typing labels on sticky-backed paper gives the project a neat, finished look. If you use that method of labeling be sure to place clear tape over each label. That is to keep the ink from smearing on the paper's smooth finish.

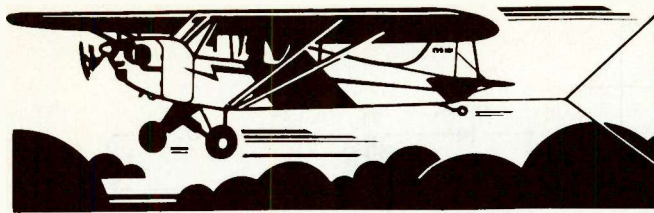

INTRODUCING

FRED-THE-HEAD

**Here's a wooden head
that can talk, sing, and yodel.**

Richard L. Pearson

□ FRED-THE-HEAD IS A UNIQUE WOODEN TALKING HEAD that's meant to be driven by any audio source, such as a radio, an amplifier, or a tape player. Although Fred is a true "block-head," his mouth is articulated and will "speak" in synchronization with any audio signal that's coupled to an electronic circuit concealed within the base that supports Fred's head. If the audio signal is speech, Fred will appear to speak. If the signal is music, Fred will appear to hum or whistle. In the time with the beat, one person even used Fred to reproduce the speech-synthesized voice of his computer.

Fred has served every purpose, from an extension speaker for a police-band monitor to an attention-getter for flea-market merchants.

Fred is powered from the 117-volt powerline. The audio input can be any suitable source having an output impedance in the range of 4 to 16 ohms. (The unit shown uses an 8-ohm speaker for Fred's "voice.") Full deflection of Fred's mouth requires a signal of .2Vp-p to be applied to the audio input—a level easily provided by even a small portable radio. Since the mouth's preamplifier has a high input impedance, it has no noticeable effect upon the signal source.

Electronic Assembly

Fred's electronics are assembled on a standard Radio Shack *Proto-board*, which has a coordinated system of holes consisting of horizontal rows designated by letters and vertical columns designated by numbers. In most instances the component leads themselves will form the circuit runs. When needed, short, non-crossing jumpers are formed from #22 solid bare hookup wire. Long runs or jumpers that *do* cross should be made from #22 solid insulated hookup wire.

Circuit Description and Operation

Take note that Fred's electronics provide no power boost or filtering to the audio delivered to his speaker. The circuitry (Fig. 1) is used simply to drive his mouth.

The input audio is applied to the speaker and across level control R6. The speaker's volume is determined by the audio-output level of the amplifier being used as the signal source. R6 provides a means of adjusting the input level to the mouth-driving circuitry for the correct "jaw" action.

U1 is a 741 op-amp; it is used as an inverting amplifier, having a gain of less than 100 at lower audio frequencies. R1, C2, R2, and the setting of R6 determine the overall gain of the

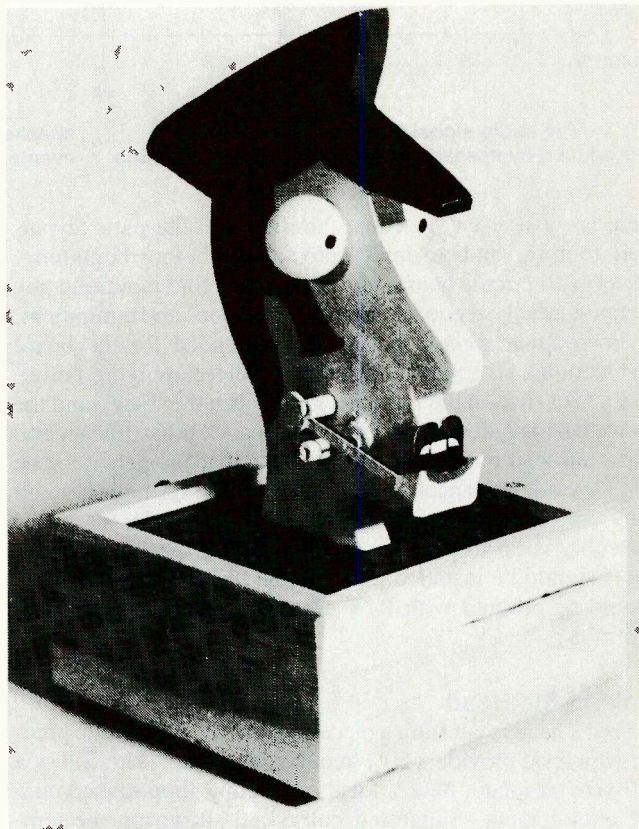

stage. Capacitor C1 serves to maintain the DC bias at pin 2. Resistors R5 and R2 establish the desired bias at pin 3 (the non-inverting input of U1). The amplified audio is taken from U1, pin 6 and coupled via C3 to the gate of SCR1.

The jaw motor (MOT1), SCR1 and the secondary of T2 are connected in series. When there is no audio applied, the current path is blocked by the non-conduction of SCR1. As audio of varying frequency and amplitude is applied to the gate of SCR1, conduction begins at varying points in the positive half-cycle; that produces a half-wave rectifier with a duty-cycle that varies at an audio rate. The varying current through the circuit causes the DC motor to actuate the jaw in time to the input audio.

The power supply consists of T1, T2, D1, U2, and capacitors C4, C5, and C6. D1 and C5 provide an unregulated 17-VDC to U2, a 7812 voltage regulator. U2 and capacitors C4 and C6 provide a low-ripple source of 12-VDC for U1. T2 can have a 6.3 volt secondary, or a 12.6 volt secondary with the connection for MOT1 taken from the center-tap.

Electronic Assembly Tips and Procedures

This one paragraph cannot hope to include all the possible bits of information you would use to assemble the project.

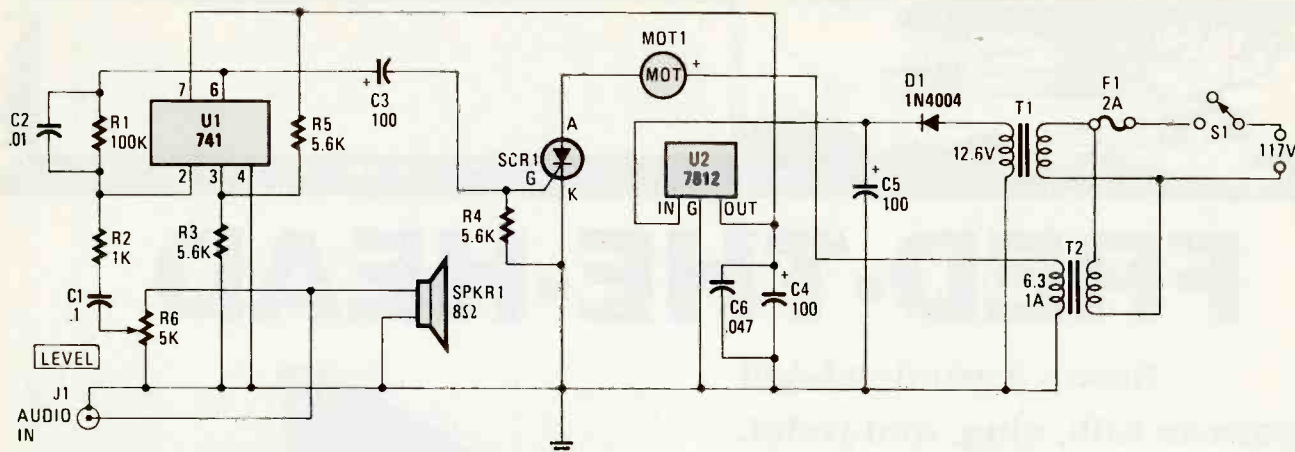

Fig. 1—The audio signal from the sound source is reproduced by speaker SPKR1. The signal across the speaker's terminals provide the sampling voltage that eventually drives Fred-the-Head.

Here are just a few: Become familiar with the parts layout, lead routing, and assembly procedures before beginning. Perform all circuit-board modifications before mounting any components. Use good soldering techniques and equipment. A low-wattage pencil iron is recommended for the board connections. Check for shorted runs before applying power. Use a heat sink on the motor shaft between the "jaw" and the motor when soldering the jaw to the shaft. Follow the general parts and lead placement shown. Note that jumpers must be installed before capacitors C4 and C5. Use insulation on all runs that are at powerline potential. The order of board assembly is up to you; but the jumpers covered by components should be installed first, and all foil carrying 117-VAC should be covered with RTV silicone rubber sealer at final assembly.

Making the Head

Fred's head is cut from a piece of 1-in. × 12-in. white pine, for which we provide a 50%-reduced template. (Fig. 2) For a full-size template, have a local photocopy shop make you a 2X enlargement. Suggested colors are shown on the template. The template also shows the required hole centers.

The large motor mounting hole is $\frac{1}{16}$ -in. Before cutting this hole, check the diameter of the motor's case. We have found that in some instances different motors are sold under the same stock number. (The size of the required hole may differ from our template.)

It is important for proper mouth action that the motor hole be perpendicular to the surfaces. The small $\frac{3}{16}$ -in. hole intersecting with the motor and wire holes is needed to provide clearance for the motor's wires. The $\frac{1}{16}$ -in. hole must be drilled first, followed by the $\frac{1}{16}$ -in. hole and finally, the $\frac{1}{4}$ -in. hole angle-drilled from the bottom—centered between the flat sides of the wood and angled as shown to match the mounting holes in the base.

The $\frac{1}{16}$ -in. diameter hole and countersink is a pilot hole needed for a #6 × $\frac{1}{2}$ -in. blunted sheet metal screw that is used to retain the motor. Its location is not critical other than it should be centered between the flat wood sides, angled approximately as shown. The $\frac{1}{2}$ -in. eye-mounting hole and the $\frac{1}{16}$ -in. jaw-stop holes aren't dimensioned.

After the holes are drilled, the head should be sanded and prepared for painting. If necessary, prepare individual templates so you can mark the color boundaries. (A suggested

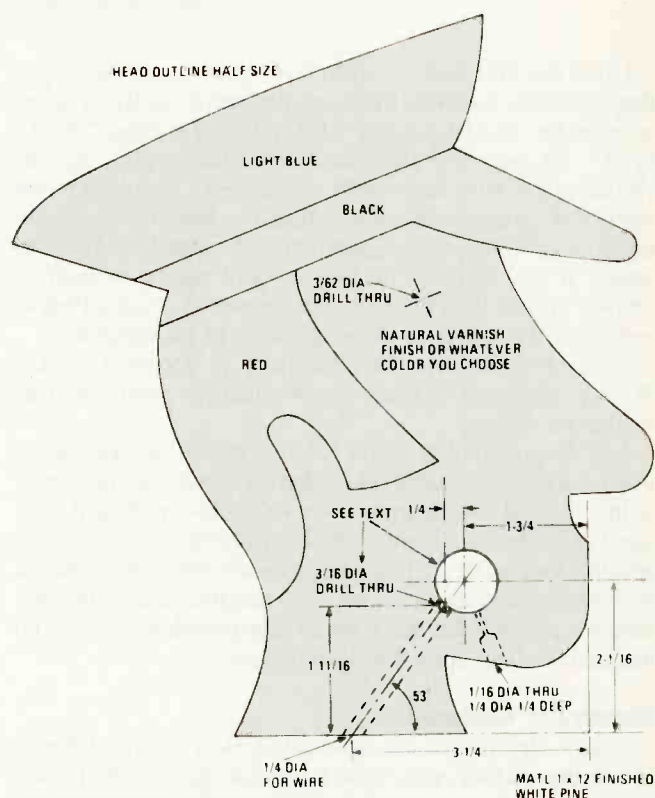

Fig. 2—This is a 50% reduction. A 2X enlargement (full size) can be obtained at your local photocopy shop.

color scheme is shown. The flesh portion may be any color that you choose. Clear varnish for the base is recommended.) The head should be painted and allowed to dry before installing the jaw, mouth, and eyeballs.

Base Assembly

The following procedures are suggested as a logical way of completing the base (Fig. 4) and head assembly. Those with woodworking experience may choose to proceed along other paths.

Our assembly was done using a glue gun and hot-melt adhesive. That method is fast, but it requires that you work quickly to prevent the cooling, thickening glue from interfering with the correct alignment of the parts. A more compliant adhesive (*Liquid Nails*, for one) can be substituted by those that tend toward panic when under pressure. The use of a

PARTS LIST FOR FRED THE HEAD

SEMICONDUCTORS

D1—1N4004 silicon rectifier diode
SCR1—200V, 6A silicon-controlled rectifier
U1—741 op-amp
U2—7812 12 volt regulator

CAPACITORS

C1—.1- μ F, 35-WVDC, ceramic disc
C2—.01- μ F, 35-WVDC ceramic disc
C3, C4, C5—100- μ F, 35-WVDC, electrolytic
C6—.047- μ F, 35-WVDC, ceramic disc

RESISTORS

(1/4-watt, 10% unless otherwise specified)
R1—100,000-ohms
R2—1000-ohms
R3, R4, R5—5600-ohms
R6—5000-ohm potentiometer with switch S1

ADDITIONAL PARTS AND MATERIALS

F1—2A fuse
J1—Phono jack
MOT1—3-6-VDC motor, Radio Shack 273-228
S1—SPST switch, part of R6
SPKR1—Speaker, 8-ohms
T1—Transformer, AC line, step-down, power; 12.6-volt, 300-mA
T2—Transformer, AC line, step down, power; 6.3-volt, 1-A

Misc.—Protoboard, predrilled, Radio Shack 276-170, wire, insulating Vinyl Sleeving, ping-pong balls (2), hot melt glue, RTV silicon rubber and household cements, toothpick, 1/4-in. wide x 1/32-in. TK brass 5 1/2-in. long. (Available at model and hobby shops), screws, wood, Masofite pegboard, rubber feet, etc.

Kits Available

A kit containing the wooden parts and plans for Fred-the-Head is available for \$21.95 plus \$4.50 shipping and handling. Detailed plans of the electronics, wood, and metal fabrications is available for \$14.95 plus \$3 shipping and handling. From Dirijo Corp., P.O. Box 212, Lowell, NC 28098

Note: The 3- to 6-volt motor (part No. RM-26) is available for All Electronics Corp., PO Box 567, Van Nuys, CA 91408; for orders only, call 800/826-5432 (nationwide); in the 213 and 818 area codes, or for information and service, call 818/904-0524.

corner clamp is recommended to ensure a professional appearance.

Referring to the illustration, assemble the front of the base and one side, then slide the top piece into the upper grooves of the assembled parts: make sure that the head mounting holes are positioned correctly. If they are satisfactory, remove the top, coat the edges of the upper grooves with adhesive, and then slide the top into place—firmly positioned against the grooves.

Check the fit of the other side piece. If it's good, coat the "active" surfaces with adhesive and assemble it to the top and front. Allow the glue to set. Take note that in the following steps the lower grooves of the front and sides aren't glued to the bottom of the base. They serve as slides, which allow the base bottom and back pieces to be removed.

Slide the bottom into the lower side grooves. Make sure that the mounting holes for the circuit board and the speaker are positioned correctly. Position the back on the assembly to check for a proper fit: The top and bottom should fit into all grooves.

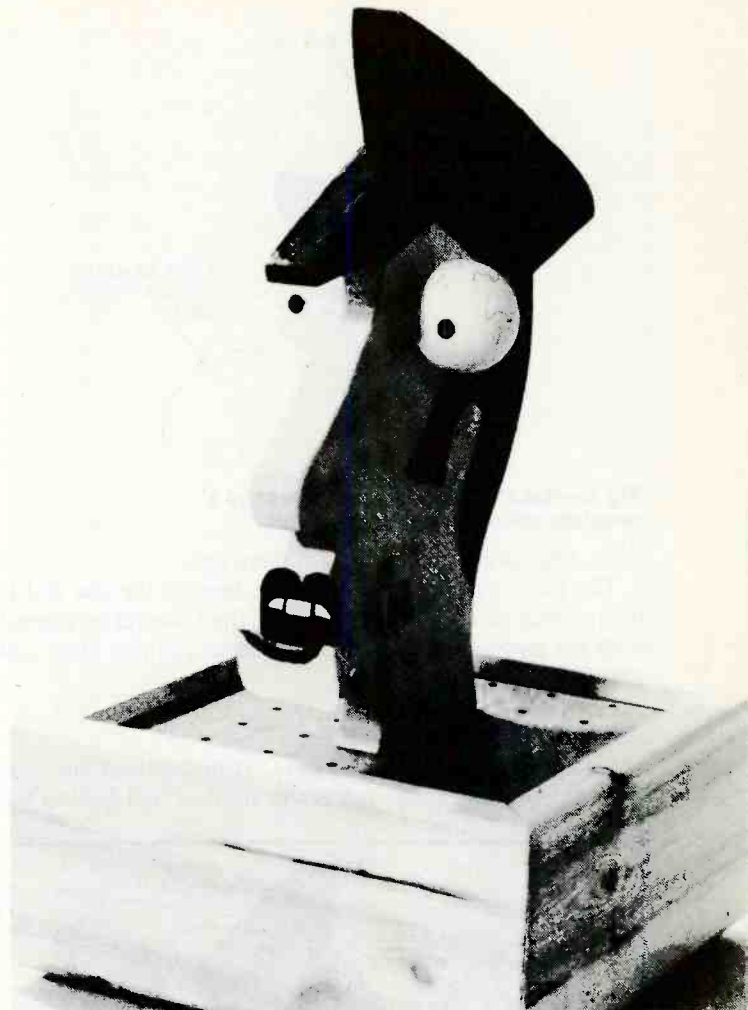

Although Fred is a true woodenhead like Pinocchio, he can also talk, sing, whistle, hum, and yodel. Although you know for certain that Fred's mouth can only open and close, when moving in synchronization with an audio signal the effect is so good you'll bet that Fred is really talking.

Remove only the back. Coat only the lower slot of the back with adhesive. Replace and center the back. The resulting bottom and back assembly serves as a removable tray for the electronic components.

Head Assembly

The motor should be a good fit to the hole. Before installing it in the head, solder the motor leads to the motor terminals using #22 stranded, insulated hookup wire or its equivalent. Allow at least 16 inches to extend from the head. From the left side of the head, insert the wires into the 1/4-in. angled hole, route them along to the motor via the 3/16-in. hole. Insert the motor—shaft first—from the left side. Center it in the head. Secure the motor in place by inserting the #6 \times 1/2-in. sheet metal screw from under the chin. **CAUTION!!** Do not overtighten and crush the motor!

Jaw Fabrication

The jaw is fabricated from 1/32-in. brass. Before drilling the hole for the motor shaft, check the diameter of the shaft because they do vary in size. A different-size hole may be required. Templates (Fig. 3) are provided for the mouth and lower lip: make "working" copies. Using a suitable adhesive, those should be mounted on a 3-in. \times 5-in. white file card. The lip portions are then painted red. Nail polish works

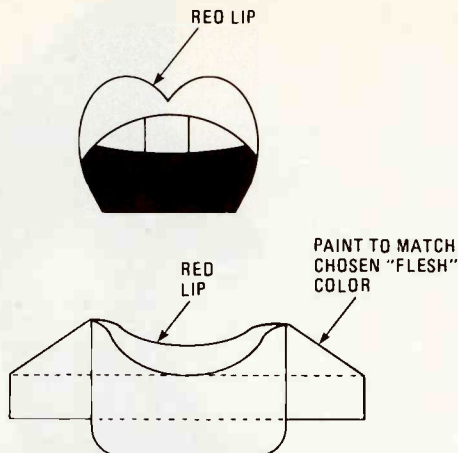

Fig. 3—Make 1.5X photocopies to use as a template when making Fred's mouth

well. After drying, carefully cut them out.

The lower lip/chin mounts on the front of the jaw and is bent around on each side: The dotted lines should be aligned with the jaw. Using a suitable household cement, align and glue the lip/chin to the jaw.

Jaw and Mouth Installation

Obtain two 3/8-in. thick spacers. With the head laid flat, right side up, place the spacers in front of and behind the

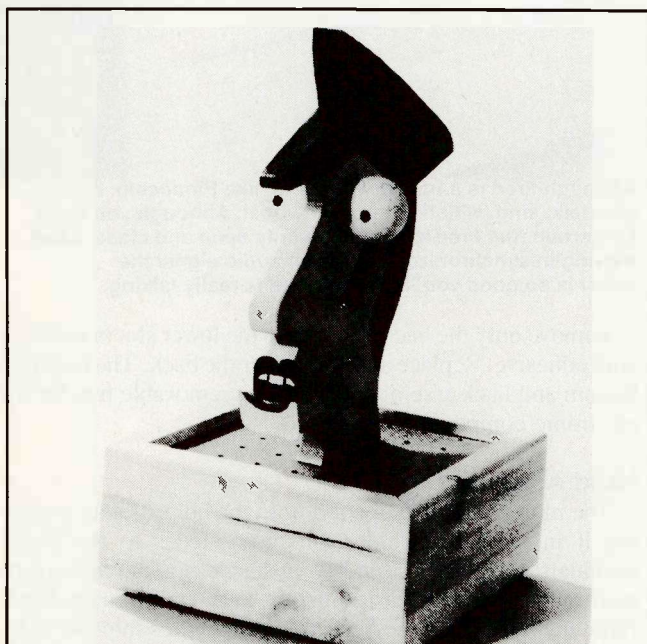

DID YOU SEE THE REAL FRED?

Which is the real Fred-the-Head: The one on the cover or the one on this page? Actually it's neither, because you can make Fred into whatever you want. The model we gave the photographer who snapped the cover is the one on this page. The photographer, however, saw Fred differently. He gave Fred the look of "another world" by painting him gray. Then he added "Groucho glasses"; but thought that made Fred look comedic, so he removed the glasses and simply pasted Groucho's eyebrows on Fred.

What do you think Fred should look like. Send us a sharp black-and-white photo of your working model. We'll print the "real winner" for everyone to enjoy. And remember, your Fred can be ugly, beautiful, comedic, tragic, ethereal, anything. Any kind of Fred-the-Head can be a "real winner."

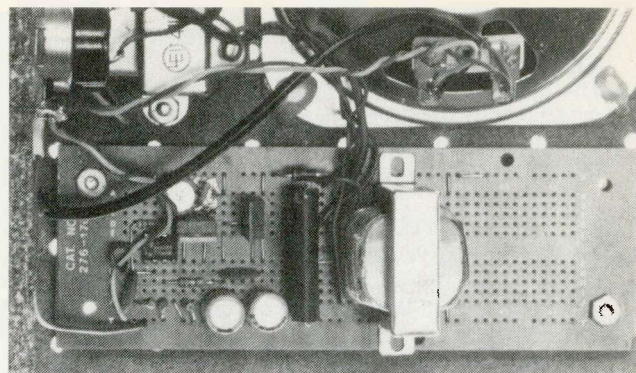

The electronic circuits that allow Fred to speak and sing are assembled on a piece of Protoboard, or any other kind of wiring board. Use whatever works best for you.

motor. Position the jaw on the motor shaft and resting on the spacers. Using a heat sink on the motor shaft and a 60-watt (or greater) soldering iron, solder the jaw to the shaft. Remove any flux residue and the spacers.

Swing the jaw down. Use a silicone-rubber adhesive or household cement. Apply the adhesive to head, and position the mouth as shown.

Eyeballs

The eyeballs are ping-pong balls. Use an awl, or some other pointed object, to pierce an eyeball-mounting hole at the point where the ball trademark appears. Insert and center a pointed party toothpick through the head's eyeball mounting hole. Place a daub of suitable adhesive on each eyeball at the pierced hole and slide the eyeballs on the toothpick and into contact with the head. When dry, use a black magic-marker to form the pupils.

Jaw-Stops

The jaw-stops should now be positioned and installed. Use this procedure. The mouth-closed stop is the *lower*, the mouth-open stop is the *upper* (Fig. 5).

Position the mouth "closed." The lower lip should fully cover the teeth when viewed from the mouth level. Secure a hollow rubber bumper of some kind—like a rubber "spacer"—below the jaw and in contact with it in the approximate location shown. Mark the position on the head where the 1/16-in. pilot hole will be drilled.

Position the mouth open. The lower lip should be at the

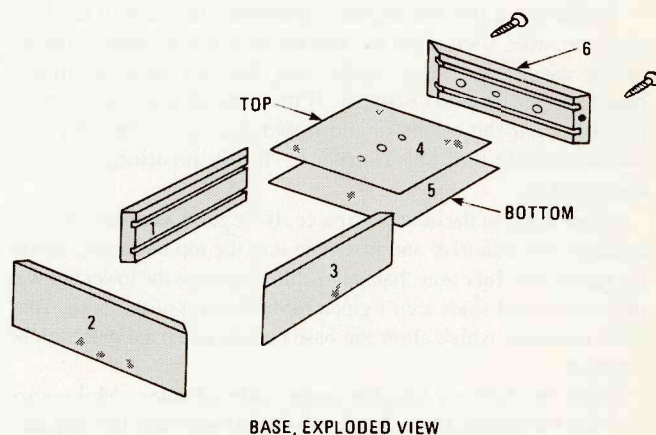

Fig. 4—If you slot the frame of the base the top and bottom can be easily secured during final assembly. Each section of the frame is 8-in. long by 3-1/2-in. high.

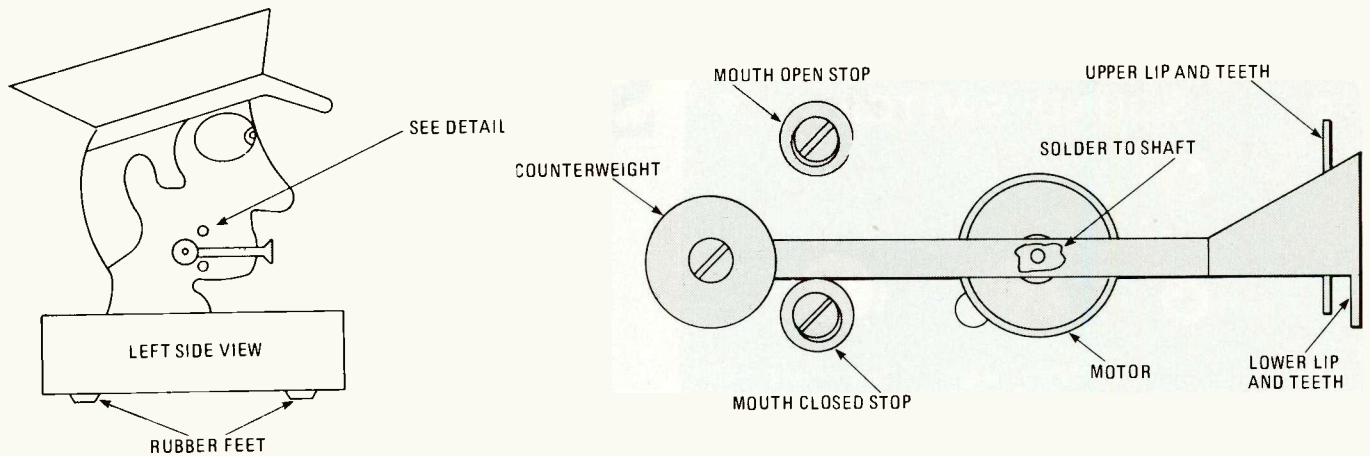
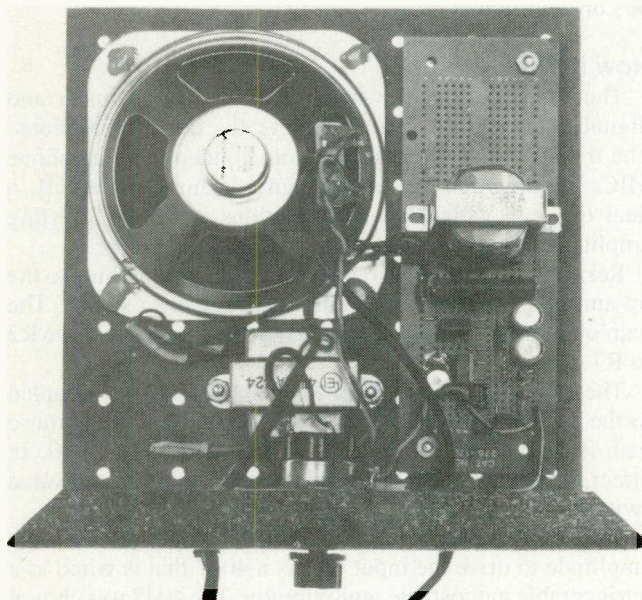

Fig. 5—The mouth mechanism should be counterweighted so that only a small torque from the motor is needed to move Fred's mouth. Two penny-size copper discs will work.



All the electronic hardware, except for the motor that drives Fred's mouth is assembled on a piece of pegboard 7-in. × 7-in. The holes provide the ventilation. Keep in mind that the larger the speaker the better Fred will sound.

lower edge of the black mouth area. Position and mark the location of the upper jaw stop. After drilling the holes, install the stops using #6 × 1-in. large panhead screws. Note that the rubber tubes should be loose and free to rotate.

Head to Base

Thread the motor wires through the $\frac{3}{8}$ -in. hole in the base. Position the head correctly and mark the location where the two holes fall on the bottom of the neck. Remove the head and drill two $\frac{3}{32}$ -in. × 1-in. deep pilot holes in the neck at those points. Install the head with screws and washers.

Testing and Troubleshooting

Before final assembly or applying power for the first time, doublecheck all point-to-point wiring and check the board assembly carefully for shorted runs or unsoldered joints. Also check for proper polarity of C3, C4, C5, and D1.

Connect the audio input to an appropriate source and

adjust the source for a normal listening level from Fred's speaker. Connect the linecord to 117-VAC and turn Fred on. Then advance the sensitivity control until the jaw action follows the speech or music being reproduced.

5. Do not adjust the control so that Fred's mouth yawns or opens on a continuous basis. To do so for long periods could cause failure of the DC jaw motor.

If the jaw fails to actuate, check for binding. Also check to make sure that the motor's polarity is correct: Incorrect polarity will only force the jaw more tightly closed.

Check for the presence of 12-VDC on pin 7 of U1.

With no audio input, also check for the presence of 6.3-VAC at SCR1's anode. At the correct audio setting there should be a varying negative DC level present.

Final Installation and Wiring

Using appropriate hardware and adhesive as required, assemble T2, the level control, the speaker, and the audio and power cords on the bottom of the base and the back assembly. Leave approximately 10 inches of free wire. Do not attach the circuit board yet. Connect all jumpers and the motor wires. Use twisted pairs for AC wiring runs and dress them away from the audio input.

Temporarily position the circuit board for testing. After successful testing and/or debugging, remove the board from the bottom of the base, cover the 117-VAC points with RTV rubber, and install the circuit board to the base. The base back assembly may now be slid into place and secured with two #6 × 1-in. cabinet screws. Install four rubber feet on the bottom of the cabinet sides: These are necessary to allow cooling air flow and adequate sound. To prevent possible electrical shock, do not eliminate any insulation features, and do not operate Fred around water or allow him to get wet.

Operation and Level Adjustment

Turn the level control and its power switch to *off*. Provide Fred with 117-VAC and a suitable source of audio. Adjust the audio source to a comfortable listening level from Fred's speaker. Turn Fred's power on and adjust the level control for proper mouth action with voice present. When the level is properly set, the mouth's action will closely follow the spoken or sung words. Do not adjust the level so that the mouth stays open. Turn Fred off when you are done with him.

Although our test and adjustment procedures have been in terms of Fred's "lip-sync'ing" to voice, keep in mind that by careful *tweaking* of level control (R1) Fred can be made to hum, sing, or whistle—at least it will appear that way. ■



SOUND- ACTIVATED SWITCH

ONE OF THE MOST MAGICAL IF NOT CONVENIENT forms of remote control is the *sound-activated switch*; a controller device that responds to some form of user-generated noise: a whistle, a clap, even a cough. Clap and the lights turn on, or off, or dim. Clap again and the hi-fi starts up, or turns off; or whatever you want to happen, happens. It's almost as good as having a personal genie, although it can't give you three wishes.

There are basically two kinds of sound-activated switch: *latching* and *timed*. The latching type responds (switches) and maintains its status until deliberately reset by a second sound, or a sequence of sounds. The timed type responds and maintains its status for a programmed amount of time, after which the device automatically resets and waits for a new trigger command (sound). Selecting the switching mode is a matter of personal desire.

To make certain that you always have the function that's needed, our sound-activated switch has both latched and timed outputs. With the latched output the load changes state each time a noise is produced. Latching can be used to turn an appliance on or off with a snap of the fingers, or even a whistle.

But flip a switch and you can operate the sound-activated switch in the timed mode. Then it can be used to keep a room

light on as long as you're making a small amount of continuous or intermittent noise.

How it Works

The sound-activated switch uses a variety of linear and digital integrated circuits to achieve the desired functions. The trigger is the audio signal from condenser microphone MIC. The microphone's audio signal is amplified by U1, a dual op-amp, which has both sections wired as inverting amplifiers connected in cascade (series).

Resistors R3 through R6 provide a "centertap" bias so the op-amps will operate with a single-ended power supply. The gain of the first stage is controlled by the ratio of resistor R2 to R7.

The output (pin 1) of the first stage is capacitively-coupled to the inverting input (pin 6) of the second op-amp, whose gain is determined by the setting of potentiometer R10. In effect, R10 determines the sensitivity of the sound-activated switch.

The output (pin 7) of the second op-amp has enough amplitude to drive the input of U2, a 4047 that is wired as a retriggerable monostable multivibrator. The 4047 was chosen because its output will remain *on* without toggling *off* as long as sounds are present in a room. During silence, the monosta-

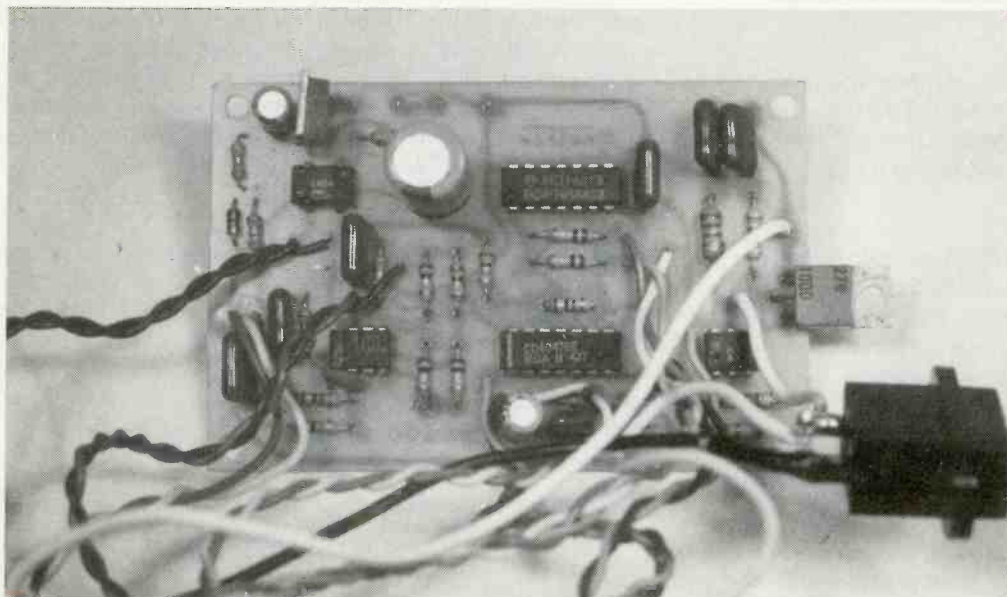

The connections to the cabinet-mounted components don't necessarily originate along the edges of the printed-circuit board. To avoid mistakes, twist together each pair of wires that connect to non-board components.

**Be like the great magicians of antiquity:
Two hand claps will make this
electronic genie do your on/off bidding.**

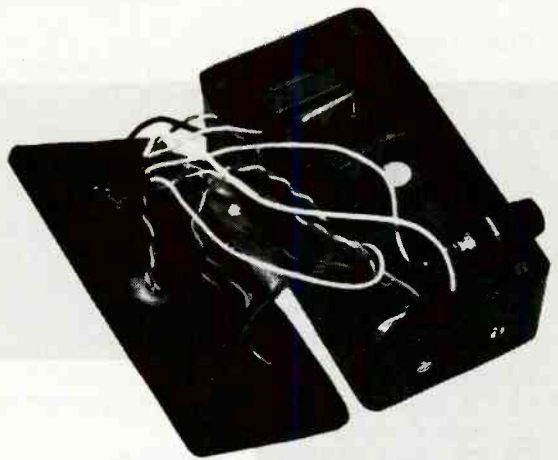

By Rich Hampton

ble will time out in 6 to 60 seconds, depending upon the setting of potentiometer R14.

Resistor R13 and capacitor C6 also regulate the firing time. Switch S1a connects C6 when in the timed mode and C5

when in the latched mode. C5 is smaller so there will be a short pulse at the output when in the latched mode.

The Q output (pin 10) of U2 is connected either to the flip-flop (U3) or to the output circuit, depending on the setting of

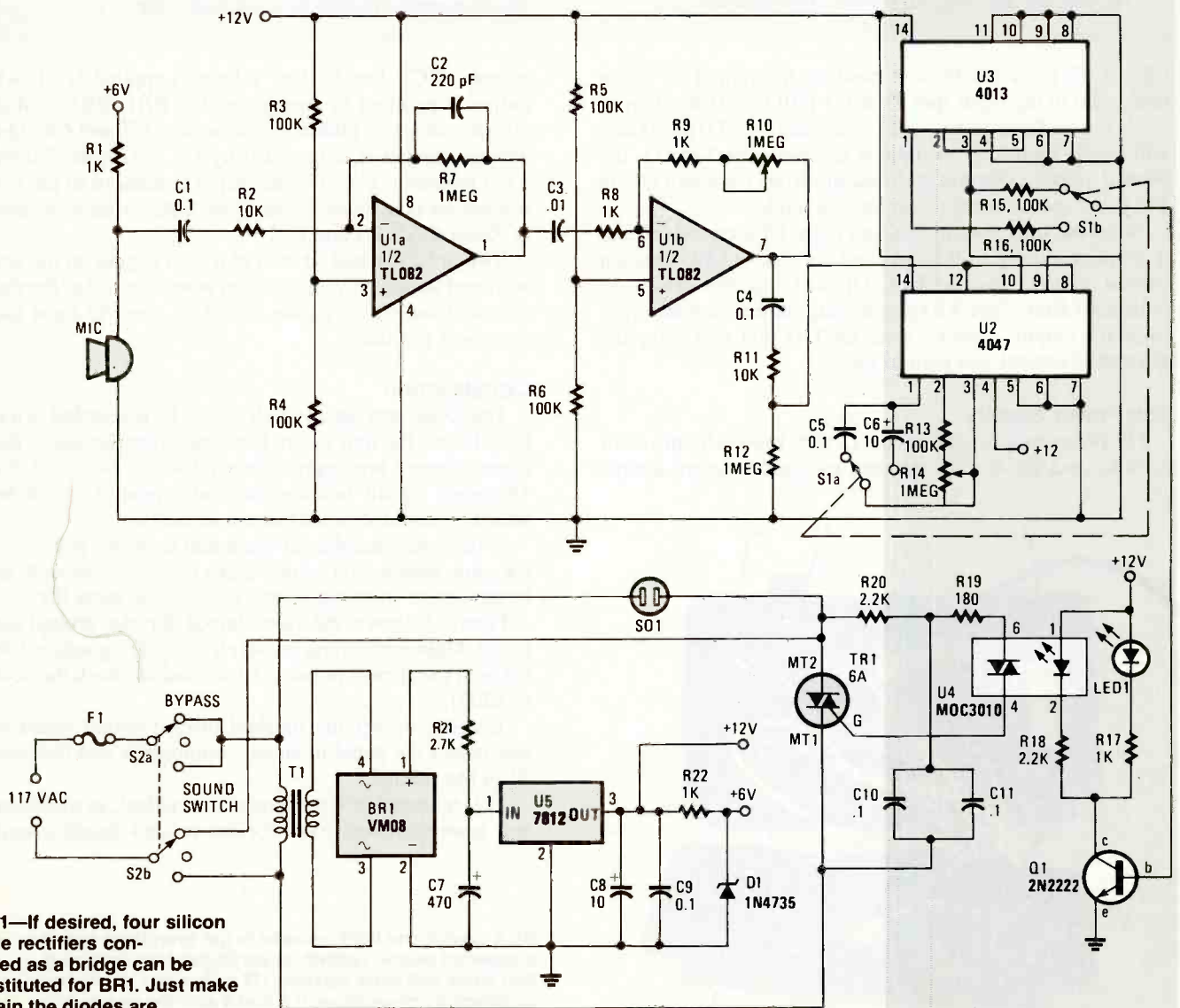

Fig. 1—If desired, four silicon diode rectifiers connected as a bridge can be substituted for BR1. Just make certain the diodes are rated at least 50V, 1A.

PARTS LIST FOR THE SOUND-ACTIVATED SWITCH

SEMICONDUCTORS

BR1—VM08 bridge rectifier, 50-V, 1A
 D1—1N4735 Zener diode, 6-V, 1-watt
 LED1—Light-emitting diode, red
 Q1—2N2222 NPN transistor
 TR1—Triac, 400-V, 6-A
 U1—Dual op-amp, TL082
 U2—CD4047 monostable multivibrator integrated circuit
 U3—CD4013 dual D flip-flop integrated circuit
 U4—MOC3010 opto-coupler (opto-isolator)
 U5—7812 12-volt regulator integrated circuit

CAPACITORS

C1, C3, C4, C5, C9, C10, C11—0.1- μ f, 250-WVDC, Mylar
 C2—220-pF, ceramic disc
 C6, C8—10- μ F, 25-WVDC, Electrolytic
 C7—470- μ F, 25-WVDC, electrolytic

RESISTORS

(All fixed resistors are 1/4-watt, 5% units unless otherwise noted.)

R1, R8, R9, R17, R22—1000-ohm
 R2, R11—10,000-ohm
 R3, R4, R5, R6, R13, R15, R16—100,000-ohm

R12—1-Megohm
 R7—1-Megohm
 R10, R14—1-Megohm potentiometer
 R18—2200-ohm
 R19—180-ohm, 1/2-watt
 R20—2200-ohm, 1/2-watt
 R21—2700-ohm, 1/2-watt

ADDITIONAL PARTS AND MATERIALS

F1—Fuse rated to match load
 MIC—Condenser microphone
 T1—Transformer: AC-line, step-down, power; 12.6-volt, 300-mA secondary winding
 S1—DPDT, toggle switch
 S2—DPDT, center-off, toggle switch
 SO1—117-VAC line socket
 Fuse Holder, printed-circuit materials, wire, solder, cabinet

PRINTED CIRCUIT BOARD AVAILABLE

An etched, drilled, and plated printed-circuit board is available from Richard Hampton, 17005 E. 4th St. South, Independence, MO 64056. Price is \$9.50 postpaid (includes postage, handling, and insurance). Missouri residents add 54-cents sales tax.

S1b. If S1 is in the latched position the output of U2 is connected to the input (pin 3) of U3 (4013), a D flip-flop.

U3 is wired with its Q (pin 5) connected to its D (pin 2) so it will toggle each time an input is received. Pin 1 of U3, the latched output, is connected to output-driver transistor Q1 via S1b if the switch is set to the latched mode.

When the voltage from S1b goes high, Q1 is turned on, and it supplies current to the opto-isolator's (U4) LED through current limiting resistor R18. Q1 also supplies current to indicator LED1. Triac TR1 gets its gate current from the opto-isolator's output. Select a triac for TR1 that will carry the amount of current you plan to use.

The Power Supply

The power supply provides the 12 volts needed for the main circuits, and the 6 volts required by the condenser micro-

phone (MIC). The AC line voltage is applied to T1, whose output is rectified by bridge-rectifier BR1. BR1's pulsating output voltage is filtered by capacitors C7 and C8. Output voltage regulation is provided by U5, a 12 volt, 3-terminal fixed regulator. U5's 12 volt output is reduced to the 6 volts needed for condenser microphone MIC by the combination of Zener diode D1 and R22.

Switch S2 is wired so as to provide a bypass for the sound-activated switch. If you also want power control of the sound-activated switch, as shown in Fig. 1, then S2 must have a center-off position.

Construction

The sound-activated switch should be assembled in a plastic cabinet. The unit shown in the photographs uses a plastic experimenter's box approximately 6-in. \times 3-in. \times 1-1/4-in.. The main circuit is assembled on a printed-circuit board which is mounted in the bottom of the box.

A full-scale template of the board is shown in Fig. 2. (If, for some reason, you cannot make the board yourself, it can be purchased from the source given in the parts list.)

Figure 3 shows the parts layout for the printed-circuit board. Make certain you install electrolytic capacitors C6 and C8 with the correct polarity. Also, double-check the polarity of LED1.

Temporarily set the finished printed-circuit board aside and install the panel-mounted components and transformer T1 in the cabinet.

T1 is mounted in the bottom of the cabinet, so make certain you leave sufficient room for the printed-circuit assembly.

It's a careful and tight squeeze to get everything into the suggested plastic cabinet. In particular, take extra care that wires and parts carrying 117 volts don't short-circuit to adjacent connections. If it looks as if the wiring will be tight, use a larger size cabinet.

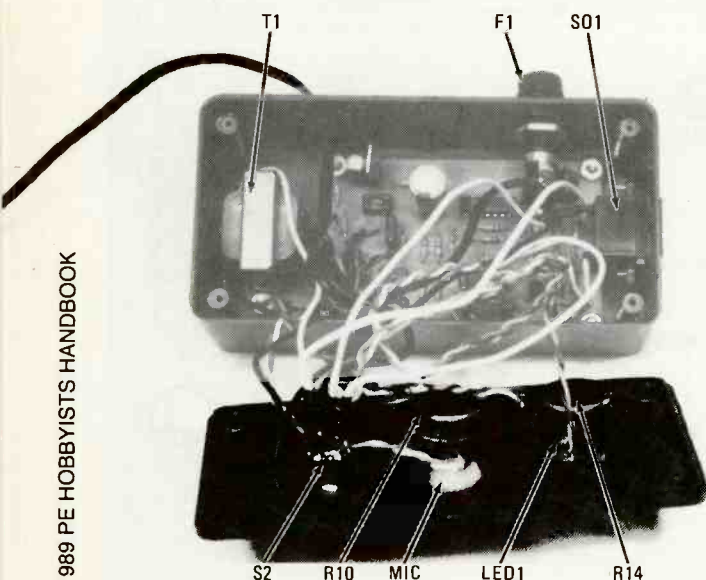

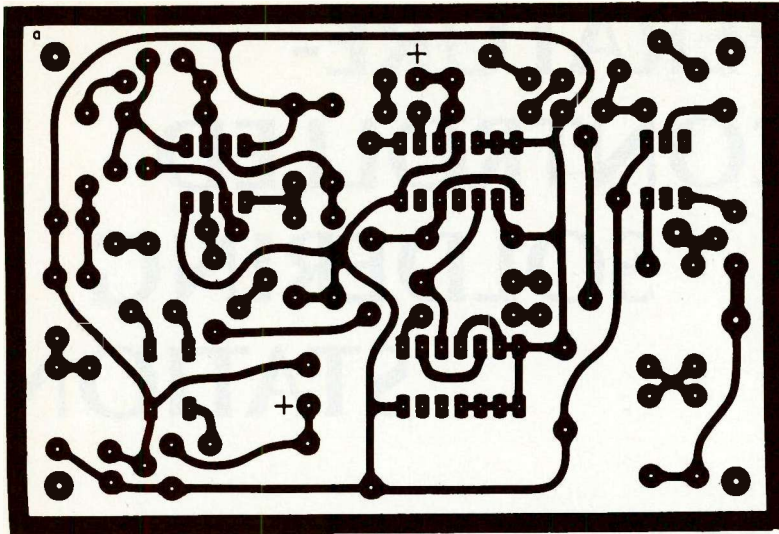
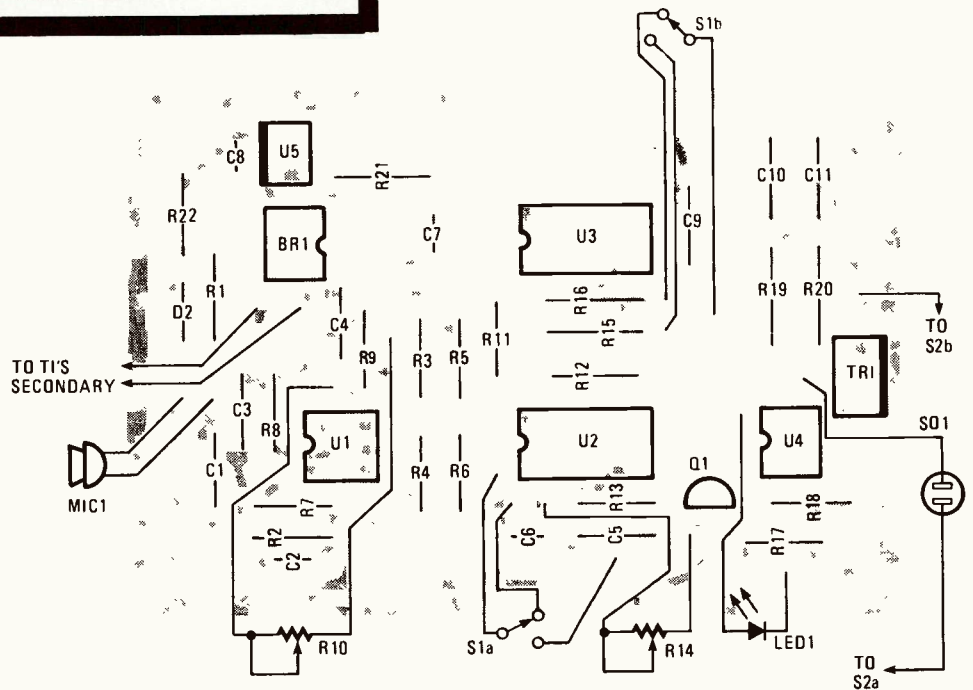

Fig. 2—This is a full-scale template for the printed-circuit board. Make the board itself from a photocopy or use a perboard layout!

Fig. 3—There's no particular order to stuffing the parts on the printed-circuit board. But take extra care that U5 and TR1 aren't reversed. The heavy line on their outline indicates their metal mounting tab.



Also, check the location of socket S01. It carries 117 volts, so be sure no front panel component touches an S01 terminal when the panel is installed.

In fact, be extra careful when routing the AC power and its associated wiring. Always insulate the AC connections with tape or heat-shrink tubing to avoid accidental short circuits; and make sure there are no exposed strands on bypass switch S2, because it's connected to the powerline.

High Power

Triac TR1 should have a heat sink installed if high-wattage loads will be used. However, don't use an external heat sink if the triac doesn't have an *insulated tab* because an uninsulated tab would place the heat sink at a line-voltage potential, which could be a hazardous situation depending on the particular assembly of your unit.

Testing and Operation

Connect a suitable load such as a 60-watt lightbulb to S01, set switch S2 to the center position, and then connect the sound-activated switch to the powerline. If S2 is set to its *bypass* position the lightbulb should turn on. When S2 is set to its *sound-switch* position the unit should go into its sound-

activated mode and the lightbulb should be out.

The sound-activate operation will depend on the setting of the function switch S1, the adjustment of sensitivity control R10, and the adjustment of delay control R14.

If the latched mode is selected, the unit should toggle each time a noise is produced. It may be necessary to adjust the sensitivity potentiometer to get the proper on-off operation.

The delay control will have little effect on the latched mode because a small capacitor (C5) is switched into the monostable multivibrator circuit.

When the timed mode is selected, the delay control will determine how long the load stays on. Keep in mind that the monostable is retriggerable. If there is continuous input (noise) the output will remain on until there is silence. In silence, the monostable times-out after a period of time determined by the setting of the delay control.

If you have difficulty in operating the unit, start troubleshooting by testing the power supply. Then follow the signal as it passes through the integrated circuits. DC levels should be observed at S1b.

Use the sound-activated switch for your convenience or to amaze your friends. It may be used on any load that does not exceed the current rating of the triac.

TEMPERATURE-CONTROLLED SOLDERING STATION

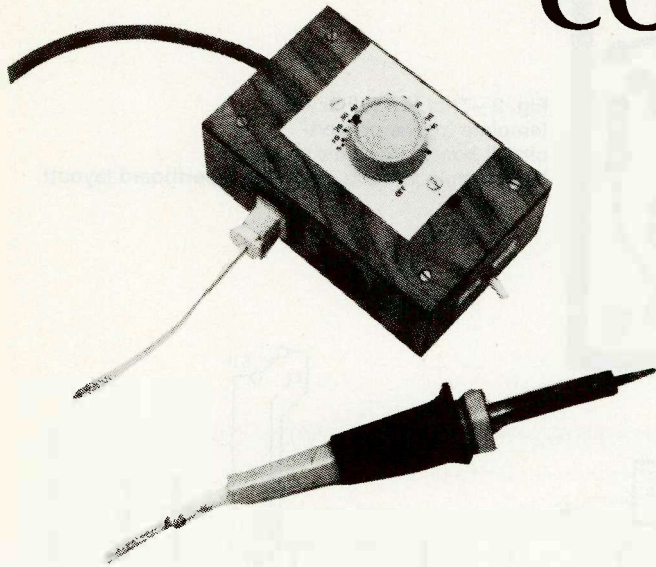

By Ladislav Hala

Avoid destroying sensitive components during soldering with this soldering-iron temperature controller.

MANY TIMES WHEN YOU SOLDER, YOUR SOLDERING iron is kept switched on for unnecessarily long periods, consuming energy and allowing the soldering iron tip to burn, and develop a buildup of oxide. All because you didn't want to face a cold iron and have to wait for about 3 minutes while the tip heats to the proper temperature.

Buying a lower-wattage iron may solve some of the problems, but new problems arise when you want to solder some heavy-duty component (such as a filter capacitor to a huge bus terminal), setting the stage for creating "cold" connections. If you've ever tried to troubleshoot some instrument in which a cold solder joint was at the root of the problem, you know how difficult such defects are to locate.

Therefore, the only possible way to satisfy all your needs is to buy a temperature controller for your soldering iron. (A problem solver, but also a pocket drainer.) Since the price of commercially available units are rather high for the beginner or even advanced hobbyist, the next best solution is to build this *Temperature-Controlled Soldering Station*.

About the Circuit

Figure 1 shows the schematic diagram of the basic Temperature-Controlled Soldering Station. As mentioned, the unit is more or less pre-made, needing only to be outfitted with an AC plug and outlet, with additional connections to the switch and the neon lamp. That very-basic circuit can be found in any of the commercially available units or in any book dealing with AC control systems.

The operation of the circuit is very simple. Once the Temperature-Controlled Soldering Station is connected to the AC line, capacitor C1 starts to charge through a variable resistor R1. Note that a diac/triac combination—forming

what is known as a *quadrac*—contained in a single TO-220 package, can be purchased from electronic parts-supply houses. When the voltage across C1 reaches the breakover voltage of the diac (around 30 to 40 volts), the diac conducts, dumping C1's charge across the gate of the triac, triggering it into conduction. The time constant for charging the capacitor is determined by the capacitor and R1 (a 200,000-ohm potentiometer, which is used as a rheostat).

Once the triac is turned on, it continues to conduct until the AC current applied to its two main terminals (MT1 and MT2) falls below the triac's minimum holding current. When the polarity of the AC input reverses, the cycle starts again, but with reversed polarity across C1. It must be noted that the triac does not conduct until the amplitude of the gate voltage reaches the breakover point, even when R1 is at minimum resistance.

The triac does not conduct unless the RC time constant is lower than the time required to change the amplitude of the mains below the breakover voltage of the diac. Thus we cannot obtain 100% (perhaps 2–98%) regulation. Note that the triac is either off or on, but not in an intermediate state, and therefore dissipates very little power. One drawback of the circuit is that a certain amount of RF interference is generated due to the fast switching of the triac.

Although power loss is negligible in either end position of R1, it is maximum in the middle position. In that position the difference of the voltage being switched is maximum, which leads to maximum power dissipation across the triac and increased generation of RF interference. The circuit can be simplified by using only a triac, diac, C1, and R1. Capacitor C2 and the inductor (L1) decrease the RF interference caused by the switching action of the triac.

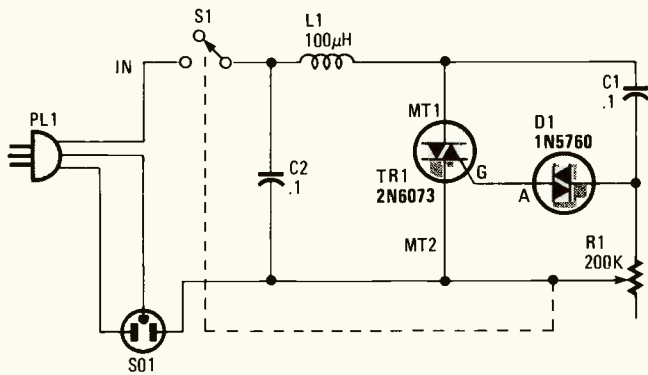

Fig. 1—When the Temperature-Controlled Soldering Station is turned on, capacitor C1 starts to charge through resistor R1. When the voltage across C1 reaches the breakover voltage of the diac (around 30 to 40 volts), the diac conducts, dumping C1's charge across the gate of the triac, triggering it into conduction. Note that although a separate triac and diac are shown, the author used a quadrac (a combination of the two contained in a single TO-220 package) in the prototype.

One Step Beyond

The basic circuit of Fig. 1 can be upgraded (as shown in Fig. 2) by the addition of a 3-position (center-off) switch and neon lamp (with self-contained resistor). Those few components make the circuit more flexible and useful. In order to get some light indication in the lower scale of the regulation, a neon lamp, NE1 (an NE2H from Radio-Shack), which has higher power capacity, has been used. The addition of the switch proved to be very useful, since the operation of the station became much easier.

Once you find a proper place for the temperature maintenance of the iron, you can switch S2 to the *thru* position without moving the setting of R1. Then when you don't need the iron for a few minutes, you may switch S2 to the *in* position. Depending on your needs and the position of R1, you can switch S2 to the *thru* position or leave it in the *in* position. For those that would like to *roll their own*, instead of buying it ready-made, the values of the components are given in the Parts List.

Generally, the triac has to have about twice the current-handling capability of the highest wattage iron that will be connected to the project. Note that there are two kinds of triac's: two mode and four mode. The four-mode device can have its main terminals in any order with respect to the gate, while two-mode units won't operate with their main terminals reversed. Be sure to check the data sheet before soldering into position.

Usually, triacs have their gates referenced to the main terminal 1 (MT1) and all conduct when the voltage between MT1 and the gate reaches about 0.9 to 1.4-volts (positive or negative) depending on whether the triac operates in quad-

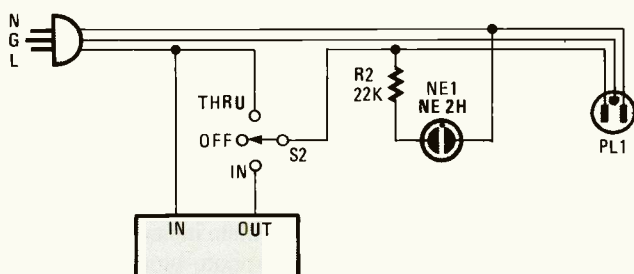

Fig. 2—The basic circuit of Fig. 1 can be upgraded, as shown here by the addition of a 3-position (center-off) switch and neon lamp (with a self-contained bias resistor).

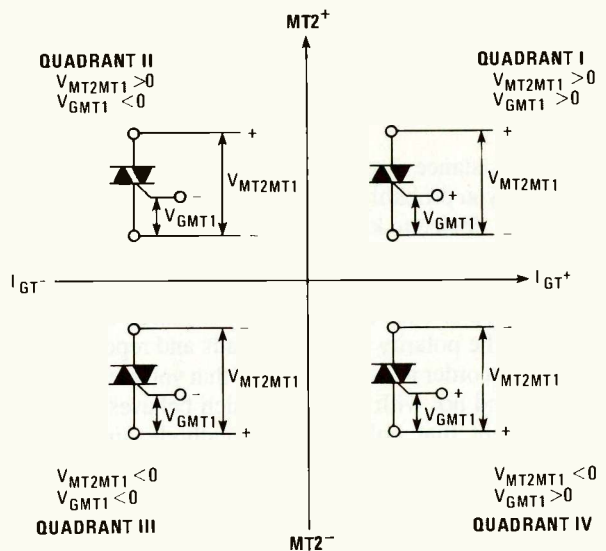
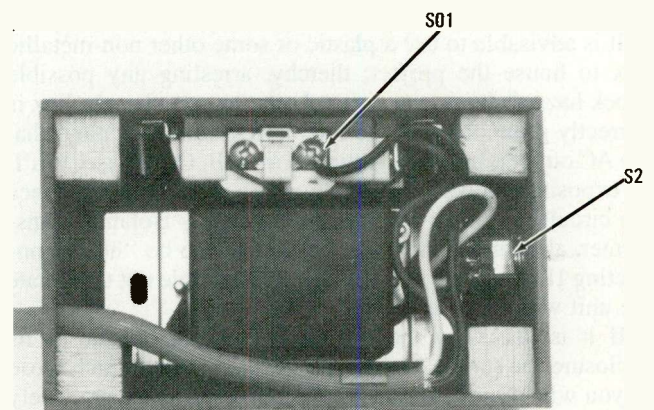

Fig. 3—Usually, triacs have their gates referenced to the main terminal (MT1) and all conduct when the voltage between MT1 and the gate reaches about 0.9 to 1.4-volts (positive or negative) depending on whether the triac operates in quadrant I or quadrant III respectively. Four-mode triacs also operate in two additional quadrants: quadrant II and quadrant IV.

rant I or quadrant III respectively. Four-mode triacs also operate in two additional quadrants: quadrant II and quadrant IV (see Fig. 3). It's important to know the lead configuration, so check the data sheet. If no data sheet is available, the gate can be distinguished from the main terminals with the aid of an ohmmeter.

Switch the ohmmeter (VOM or DMM) to the lowest resistance range to promote current flow (which must be greater than the holding current) through the device-under-test. Measure the resistance between all leads of the triac. If the resistance between any two leads is low (regardless of polarity), you located the gate and MT1, making the final lead (assuming a good unit) MT2. Check the resistance between the first two leads (the gate and MT1) the lead MT2. The resistance between MT2 and either MT1 or the gate should be at or near infinity (without respect to polarity).

Now with one test lead connected to MT2, connect the other test lead to one of the leads (which we now know have to be MT1 and the gate) and touch MT2 to the last lead. If the meter reading drops to some value substantially lower value than that obtained during your preliminary measurements, the lead shorted to MT2 is the gate. If not, with MT2 still



The prototype was built in an old light-dimmer case, but could easily have been built on perf- or printed-circuit board.

connected, switch the connection of the other two leads, and again short MT2 to the remaining lead. Now, while holding the test-lead in contact with MT2, release the test-lead from the gate.

If the resistance does not stay low in any one of the test situations, you probably don't have sufficient current flowing through the device to keep it turned on. This may be true for high current devices. In that case, try to use another VOM that provides a higher current for resistance measurements. Also, it helps to have a fresh battery installed in the VOM.

Change the polarity of the test-leads and repeat the whole procedure in order to assure yourself that you are dealing with the Triac and not with an SCR, which behaves just like the Triac, except that only when its cathode and anode are connected to negative and positive terminals (respectively) with its gate being triggered with positive voltage only (referenced to the cathode).

Construction and Applications

Putting the Temperature-Controlled Soldering Station together is quite simple and rather straightforward. The author's prototype unit was built inside of a discarded light-dimmer housing. However, the circuit might just as easily be built on perfboard or, if so desired on printed-circuit board—the choice is up to you. If perfboard is used, mount all components to the board. Then using insulated wire, connect the components as shown in Fig. 1. Figure 4 is a block diagram illustrating the finished *basic* circuit (with the box representing the circuit board).

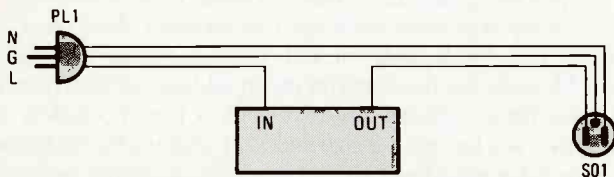

Fig. 4—This block diagram illustrates the finished *basic* circuit (with the box representing the circuit board). If your circuit is to include the neon-lamp indicator and switch S2, connect those components to the circuit, guided by Fig. 2.

If your circuit is to include the neon-lamp indicator and switch S2, connect those components to the circuit, guided by Fig. 2. For safety reasons, it should be remembered that the "hot" side of the line cord must be connected to the unit through switch S1. A 3-prong line cord must be used, with the third wire connecting the ground of the outlet with the ground of SO1 (to which the soldering iron is connected).

It is advisable to use a plastic or some other non-metallic box to house the project; thereby, arresting any possible shock hazard. If you use a metal box, be sure that the box is correctly grounded (via the line cord ground lead) and that the AC outlet is properly grounded as well. Otherwise, you'll be exposing yourself to almost certain shock hazard. Since the circuit described here does not use any isolation transformer, all components must be assumed to be "hot," conducting 117-volts AC. Therefore, it's advisable not to operate the unit without its case.

If it is necessary to operate the circuit outside of its enclosure, be sure to stick to the *one-hand* rule (which those of you with an military background in electronics are surely familiar with). The one-hand rule says that the unit should be operated with only one hand, while the other must be away from the vicinity of the circuit e.g., in the pocket. As an

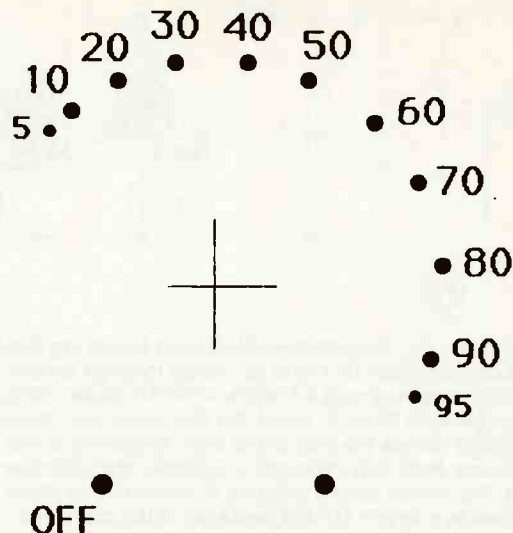

Fig. 5—To make the project easy to use, the controls should be labeled, as the author's, with a calibrated scale (like this one). Note this scale may be lifted from the page and used to adorn the project housing or you can concoct your own.

added precaution, remove all jewelry while operating the circuit.

Once the unit is assembled, the testing procedure is easy. First test for any short circuits with an ohmmeter connected between line and neutral cables of the line cord. The ohmmeter should show infinite resistance in either position of S2. Then switch S1 to the *off* position, and connect the unit to the AC outlet. Switch S2 to the *thru* position, and NE1 should light.

Calibrating the unit is a straightforward task. Simply connect a load to the output and measure the voltage in the *thru* (100% V) position. Then flip S2 to the *in* position and calibrate the R1 setting according to the voltage readings

PARTS LIST FOR THE TEMPERATURE-CONTROLLED SOLDERING STATION

- C1, C2—0.1- μ F, 400-WVDC, ceramic capacitor
- D1—1N5760, 1N5761, or similar bilateral trigger (Diac)
- L1—100- μ H, 2-A RF choke (Radio Shack 273-102 or similar)
- NE1—NE2H, or similar neon lamp (RS 272-1102, see text)
- R1—200,000-ohm linear potentiometer
- R2—22,000-ohm, 1/4-watt, 5% resistor (see text)
- S1—Single-pole, single-throw (SPST) switch
- S2—Single-pole, 3-position, center-off switch (see text)
- TR1—2N6073 4-A, 400-PIV (four mode) or 2N6343 12-A, 400-PIV (two mode) Triac
- Three-conductor AC line cord with molded plug, AC socket, enclosure (non-metallic), wire solder, hardware, etc.

across the output terminals.

There are many more applications for this project than the one for which it is intended. The circuit can find use in any part of your household. It can be used to control any instrument or tool that is AC powered; regulate incandescent lights in your living room, greenhouse, or photo-processing room. (Note that the circuit cannot be used to control fluorescent lights.) In fact, there are so many applications that you are limited only by your own imagination. ■

No other training—in school, on the job, anywhere—shows you how to troubleshoot and service computers like NRI

HARD DISK

20 megabyte hard disk drive you install internally for greater data storage capacity and data access speed.

PACKARD BELL COMPUTER

NEC V40 dual speed (4.77 MHz/ 8 MHz) CPU, 512K RAM, 360K double-sided disk drive.

MONITOR

High-resolution, non-glare, 12" TTL monochrome monitor with tilt and swivel base.

DIGITAL MULTIMETER

Professional test instrument for quick and easy measurements.

LESSONS

Clearcut, illustrated texts build your understanding of computers step by step.

SOFTWARE

Including MS-DOS, GW BASIC, word processing, database and spreadsheet programs.

TECHNICAL MANUALS

With professional programs and complete specs on Packard Bell computer.

DISCOVERY LAB

Complete breadboarding system to let you design and modify circuits, diagnose and repair faults.

DIGITAL LOGIC PROBE

Simplifies analyzing digital circuit operation.

Only NRI walks you through the step-by-step assembly of a powerful XT-compatible computer system you keep—giving you the hands-on experience you need to work with, troubleshoot, and service all of today's most widely used computer systems. You get all it takes to start a money-making career, even a business of your own in computer service.

No doubt about it: The best way to learn to service computers is to actually build a state-of-the-art computer from the keyboard on up. As you put the machine together, performing key tests and demonstrations at each stage of assembly, you see for yourself how each part of it works, what can go wrong, and how you can fix it.

Only NRI—the leader in career-building, at-home electronics training for 75 years—gives you such practical, real-world computer servicing experience. Indeed, no other training—in school, on the job, anywhere—shows you how to troubleshoot and service computers like NRI.

You get in-demand computer servicing skills as you train with your own XT-compatible system—now with 20 meg hard drive

With NRI's exclusive hands-on training, you actually build and keep the powerful new Packard Bell VX88 PC/XT compatible computer, complete with 512K RAM and 20 meg hard disk drive.

You start by assembling and testing the "intelligent" keyboard, move on to test the circuitry on the main logic board, install the power supply and 5 1/4" disk drive, then interface your high-resolution monitor. But that's not all.

Only NRI gives you a top-rated micro with complete training built into the assembly process

Your NRI hands-on training continues as you install the powerful 20 megabyte hard disk drive—today's most wanted computer peripheral—included in your course to dramatically increase your computer's storage capacity while giving you lightning-quick data access.

Having fully assembled your Packard Bell VX88, you take it through a complete series of diagnostic tests, mastering professional computer servicing techniques as you take command of the full power of the VX88's high-speed V40 microprocessor.

In no time at all, you have the confidence and the know-how to work with, troubleshoot, and service every computer on the market today. Indeed you have what it takes to step into a full-time, money-making career as an industry technician, even start a computer service business of your own.

No experience needed, NRI builds it in

You need no previous experience in computers or electronics to succeed with NRI. You start with the basics, following easy-to-read instructions and diagrams, quickly

moving from the fundamentals to sophisticated computer servicing techniques. Step by easy step, you get the kind of practical hands-on experience that makes you uniquely prepared to take advantage of every opportunity in today's top-growth field of computer service.

What's more—you learn at your own pace in your own home. No classroom pressures, no night school, no need to quit your present job until you're ready to make your move. And all throughout

your training, you have the full support of your personal NRI instructor and the NRI technical staff always ready to answer your questions and give you help whenever you need it.

Your FREE NRI catalog tells more

Send today for your free full-color catalog describing every aspect of NRI's innovative computer training, as well as hands-on training in robotics, video/ audio servicing, electronic music technology, security electronics, data communications, and other growing high-tech career fields.

If the coupon is missing, write to NRI School of Electronics, McGraw-Hill Continuing Education Center, 4401 Connecticut Avenue, Washington, DC 20008.

PC/XT and XT are registered trademarks of International Business Machines Corporation

NRI

School of Electronics

McGraw-Hill

McGraw-Hill Continuing Education Center
4401 Connecticut Avenue, Washington, DC 20008

For career courses approved under GI bill
 check for details

Check one FREE catalog only

<input type="checkbox"/> Computers and Microprocessors <input type="checkbox"/> Robotics <input type="checkbox"/> TV/Video/Audio Servicing <input type="checkbox"/> Computer Programming	<input type="checkbox"/> Security Electronics <input type="checkbox"/> Electronic Music Technology <input type="checkbox"/> Basic Electronics <input type="checkbox"/> Data Communications
---	---

Name _____ (please print) Age _____

Address _____

City/State/Zip _____ 9-049

Accredited by the National Home Study Council

Pilot Carrier Frequency Standard



By Luther M. Stroud

This project turns most any FM monaural radio into an accurate signal source for experimenting or calibrating.

AS AN ELECTRONICS ENTHUSIAST OR TECHNICIAN, IN AN ERA of high-performance digital equipment, surely you've had need of a calibrated signal source to check the accuracy of some piece of test equipment, or a stable clock source for experimental purposes. Of the hundreds of circuits that have been published for low-frequency squarewave oscillators, almost all of them suffer from thermal drift and instability due to changes in power-supply voltage.

Crystal oscillators offer a vast improvement in stability, but they work at only one frequency. That means, to use such a circuit in any meaningful way, you must first obtain a crystal and build an oscillator circuit to make it work. Then, once it's working, you must laboriously hook up decade counter/dividers to divide the frequency down to something more useful. And the problem is further compounded by the circuit in which the crystal is used.

The crystal manufacturer may specify the accuracy to be

within $\pm .005\%$; but, the crystal may behave differently in your circuit. So unless the output frequency is measured with test equipment of known accuracy, you will never really know exactly what you're getting. And that's where our little project comes in: To those who don't have access to expensive equipment to measure and trim an oscillator to exact frequency, this project offers an inexpensive alternative. It borrows accuracy from another source—namely, the stereo pilot carrier (broadcast at low amplitude in the stereo program) from any local FM-stereo radio station.

When an FM radio station broadcasts in stereo, the low-amplitude pilot carrier is used by the multiplex decoder in a stereo receiver to recreate the right and left channel audio and turn on the stereo indicator. But in a monaural radio, the stereo pilot is not used (there's no separation of left and right channel signals), therefore both signals are delivered to one speaker. The FCC specifies the pilot carrier to be $19 \text{ kHz} \pm 2$

Hz, which translates to $\pm .001\%$ —a rather tight tolerance. In fact, the measurements that I made of the pilot with a lab-grade frequency counter showed that most stations were $\pm .00015\%$ of that 19 kHz signal. Let us now look into how this project makes use of that accurate signal by converting it to something more useful.

About the Circuit

Refer to Fig. 1, the schematic diagram of

The design of the project is simple enough for perfboard construction. Following the author's layout is highly recommended, even if you decide to go the printed-circuit route. Because of the high gain of U1, lead length should be kept short to minimize noise pickup.

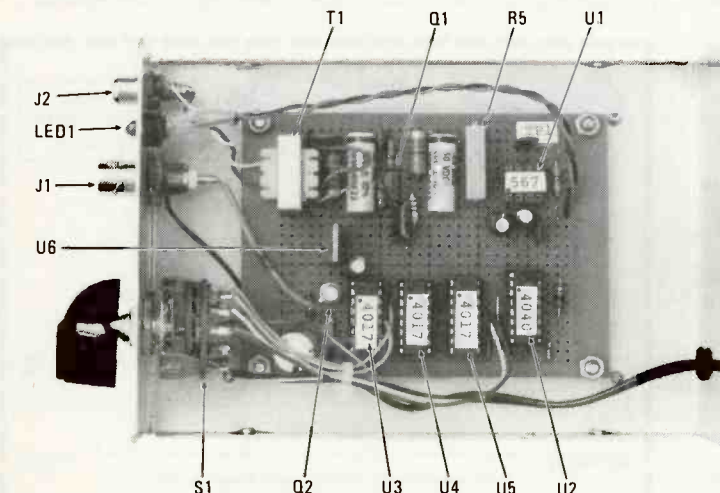

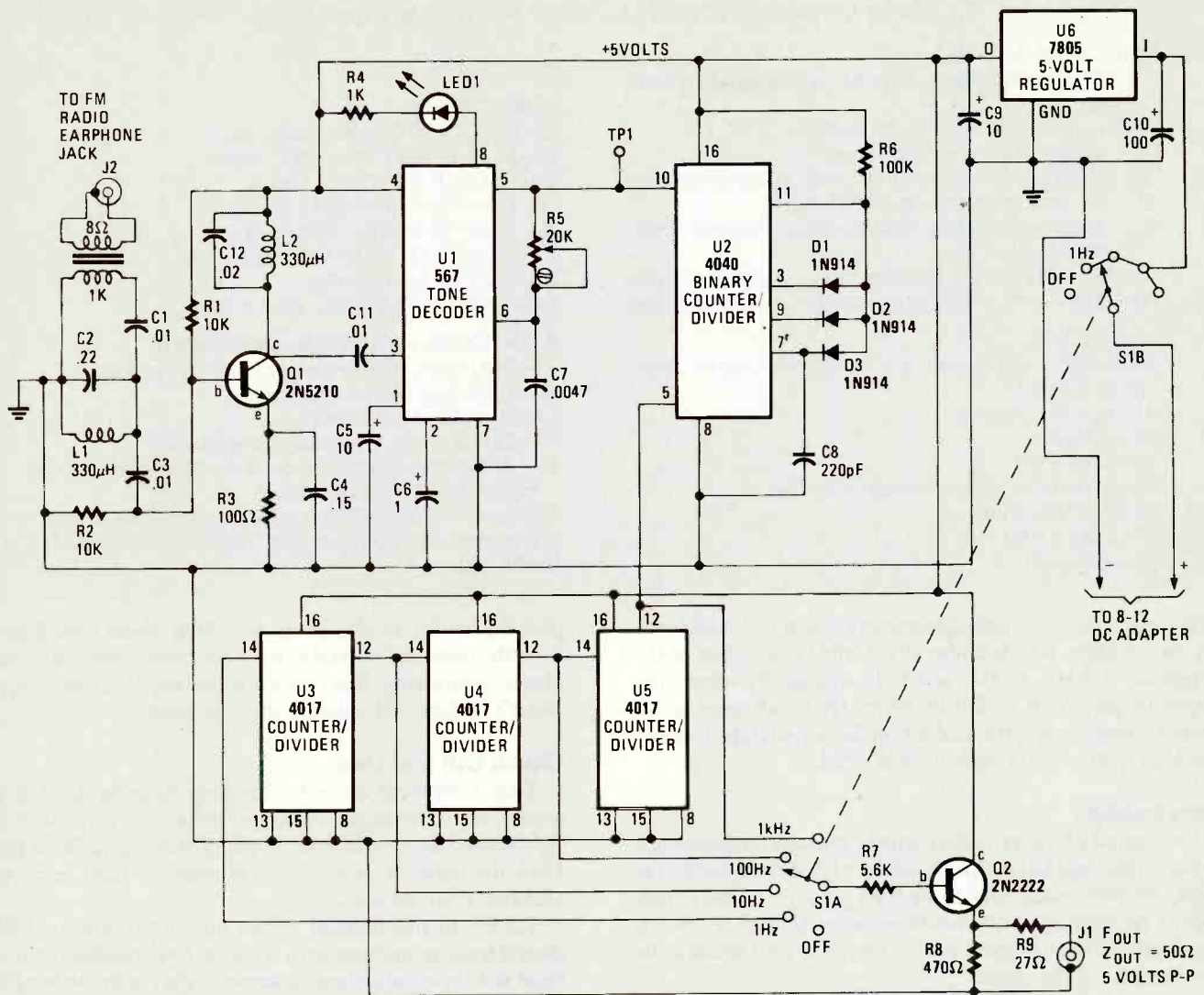

Fig. 1—Audio from the earphone jack of an inexpensive monaural FM portable radio is coupled through T1—an audio transformer, which provides isolation and impedance matching—to the filter stages of the circuit, which strips the carrier (using two tuned parallel-resonate tank circuits) from FM stereo broadcasts.

the circuit that extracts the carrier from FM broadcasts. Audio from the earphone jack of an inexpensive monaural FM portable radio is coupled through T1—an audio transformer, which provides isolation and impedance matching—to the first filter stage. A parallel resonate tank circuit, formed by C2 and L1, tuned to 19 kHz sharply attenuates all signals except the 19 kHz pilot signal.

The remaining signal, a combination of a 19-kHz sinewave and high-frequency program audio, is coupled by C3 to an active filter—a class “A” amplifier, consisting of Q1, R1, R2, and R3. Another tank circuit, formed by C12 and L2, and also tuned to 19 kHz, is placed in the collector circuit of Q1. C4 bypasses R3 to prevent degenerative feedback. The amplifier’s gain is highest at the 19 kHz resonant frequency due to the tank circuit.

The tank circuit should provide about 50 millivolts of output with distortion and noise, which is then sent via C11 to the input of the 567 tone decoder—a special-purpose device intended primarily to tell logic circuits when a signal tone is present at its input. A typical application would be to detect when a button of a touch-tone phone is pressed.

The chip, which has high gain and good noise immunity, is capable of detecting a 40-millivolt signal in very heavy noise, provided that the signal is within its detection band. High level signals (above 200 millivolt) tend to cause some instability. The device is useable at frequencies of from 0.1 to 500 kHz.

The voltage-controlled oscillator’s center frequency is set to operate at 19 kHz with values specified for R5 and C7. C5 and C6 set up the band-width and damping of the PLL. R4 and LED 1 form an indicator circuit to let you know that the PLL is locked onto the incoming signal.

At Pin 5, a squarewave signal of 5-volts peak-to-peak is generated at a 90-degree phase angle to the incoming signal when locked. At Pin 4 a regulated 5 volt power supply is used because the VCO center frequency is somewhat affected by power supply variations.

The 19-kHz squarewave is applied to the input of a binary ripple counter (U2). D1, D2, D3 and R6 form a 3-input AND gate that resets U2 every 19 counts, making it work as a divide-by-N counter. C8 helps to widen the reset pulse and may not be needed in some cases. The output of U2 at pin 5 (a

PARTS LIST FOR THE PILOT CARRIER FREQUENCY STANDARD

SEMICONDUCTORS

D1-D3—1N914 general-purpose, small signal, silicon diodes
 LED1—Jumbo red light-emitting diode
 Q1—2N5210 NPN silicon transistor
 Q2—2N2222 NPN general-purpose, silicon transistor
 U1—567 tone decoder, integrated circuit
 U2—4040 ripple-carry, binary counter/divider, integrated circuit
 U3-U5—4017 decade counter/divider, integrated circuit
 U6—7805 5-volt, 1-A voltage regulator, integrated circuit

RESISTORS

(All resistors are 1/4-watt, 5% fixed units, unless otherwise noted.)
 R1, R2—10,000-ohm
 R3—100-ohm
 R4—1000-ohm
 R5—1000-ohm, multi-turn potentiometer
 R6—100,000-ohm
 R7—5600-ohm
 R8—470-ohm

R9—27-ohm

CAPACITORS

C1, C3, C11—0.01- μ F, ceramic disc
 C2, C12—0.02- μ F, 50-WVDC Mylar
 C4—0.15- μ F, 50-WVDC, Mylar
 C5, C9—10- μ F, 16-WVDC, electrolytic
 C6—1- μ F, 16-WVDC, electrolytic
 C7—0.0047- μ F, 50-WVDC, Mylar
 C8—220-pF, ceramic disc
 C10—100- μ F, 25-WVDC, electrolytic

ADDITIONAL PARTS AND MATERIALS

J1—BNC-type, female panel-mount connector
 J2—RCA-type female phono jack
 L1, L2—330- μ H, RF choke
 S1—Double-pole, 6-position, rotary switch
 T1—Audio transformer, 8-ohm to 1000-ohm (Radio Shack #273-1380 or similar)
 Printed-circuit or perfboard material, enclosure, 8- to 12-volt plug-in DC power supply, hardware, wire, solder, knobs, etc.

1 kHz nearly symmetrical squarewave) is sent to 3 additional decade counters, which further divide the 1 kHz output of U2 to provide 100 Hz, 10 Hz, and 1 Hz signals. S1 selects the output frequency to be fed to buffer Q1 (configured as an emitter follower). R7, R8, and R9 set the output impedance to 50 ohms with a 5-volt peak-to-peak level.

Construction

The design of the project is simple enough for perfboard construction, and following the author's layout (see photos) is highly recommended. Due to the high gain of U1, lead length should be kept short to minimize noise pickup. A 5-volt regulated and well filtered power source is also needed for best stability of the circuit.

A 9-volt battery might be used for a power source. But, since the circuit draws about 35 mA, a plug-in DC power supply capable of supplying 9- to 12-volts with a current capacity of at least 50 mA is recommended and is less costly for extensive use. The positive power-source wiring to S1 should be double-checked before power is applied to the circuit to insure that the proper pole is being used. A wiring mistake there could destroy the chips.

The value of C8 is not critical—any value between 100 and 470 pF is just fine. When wiring LED1, the lead nearest the flattened side (cathode) goes to R4. A template of the front

panel layout is provided in Fig. 2, which can be copied or cut from the page and affixed to the front panel, with some clear plastic laminating film covering the panel to protect the paper's surface and enhance the appearance.

Check Out and Use

Take a moment to look over your handiwork. Are the diodes and electrolytic capacitors polarized correctly? Are the red and white wires from T1 going to the audio input jack? Have the chips been correctly oriented in their respective sockets? If so, proceed.

Set R5 to mechanical center and apply power. LED1 should light up momentarily. Tune an FM portable radio to a local station broadcasting in stereo. Apply audio to the project from the radio's earphone jack using a suitable cable. Advance the volume control about halfway, and if there is a tone control, set it to maximum treble. LED 1 should light, indicating your project is locked onto the stereo pilot carrier.

The adjustment of R5 can be optimized by reducing the radio volume and readjusting R5 to lock in the circuit with a minimal audio level. A small speaker can be connected to the output to test for the presence of proper signals. The above adjustments can be made with no special equipment, but if you are purist and have access to test equipment, do the following. Without audio applied, connect a scope to the project's output and select the 1000 position.

Adjust R5 for a period of 1 millisecond: 1 kHz if you are using a frequency counter. Doing things in that manner is preferred over monitoring TP1 for 19 kHz, because TP1 is a rather high-impedance point and even a $\times 10$ probe will cause a shift in the center frequency. When audio is applied and the PLL locks, the output will be as accurate as the pilot carrier.

(Continued on page 156)

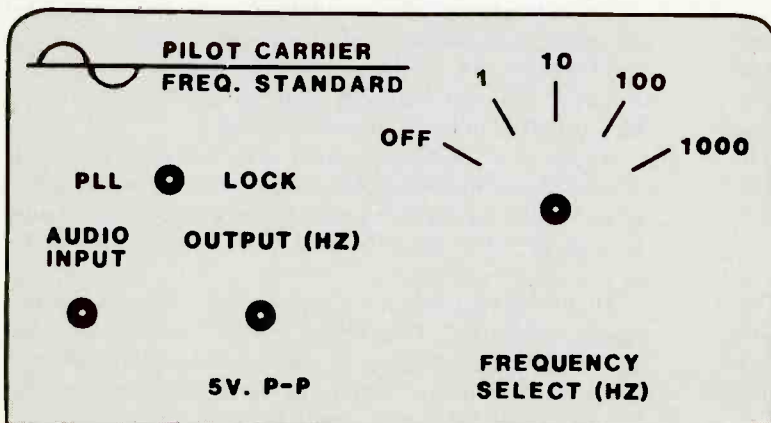

Fig. 2—This front-panel template can be copied or cut from the page and affixed to the front panel, with clear plastic laminating film covering the paper's surface to protect the project and enhance its appearance.

Build the...

DIGI-LYZER IC TESTER

By W. Schopp

Now you can quickly check questionable IC's to determine whether they are worth keeping or not

YOU'VE STRUGGLED FOR DAYS GETTING YOUR CIRCUIT to operate just the way that you want it to. And now it's time to clean up. You put away your tools and meter, fold up your schematics and notes, sweep off your workbench. Suddenly, there they are—those questionable chips. You vaguely remember switching those *chunks of silicon* for new ones when some part of the circuit failed to perform as intended.

But then, suddenly, your memory takes a complete leave of absence; and you can't recall whether changing the chip made any difference. And so the problem becomes painfully clear: You hate to put those chips back into your inventory with the good ones only to give you possible problems at some future date.

You also don't want to throw them away because they not only cost good money (and the cost of survival being what it is these days), but they also might save you a trip to town if you happen to need that particular chip again. Anyone who has designed or built electronic circuits around digital IC's can certainly relate to that situation.

You say to yourself, "I'll just put them in this ash tray and check them later *when I get more time.*" But the only problem is that *the time* never seems to materialize. And all too soon you notice that you have an ash tray full of chips from other projects. Does that sound like a familiar tale to you?

The Solution

What is really needed is a simple checker that is able to handle all digital chips. The criteria for such a circuit might include: a zero insertion-force socket, so that all you'd have to do is drop the chip into the socket without damaging the IC pins, or having to do any soldering or breadboarding. There should be a way of applying power to any pin of the Chip-Under-Test (CUT) regardless of its pin configuration, and you should also be able to apply a voltage to any pin simply by pushing a button.

In addition, it should also have status indicators so that you can tell to which pins voltage is applied and which pins are at ground potential. And how about a way to tell if the voltage on the pin is applied directly through a pushbutton switch, or if

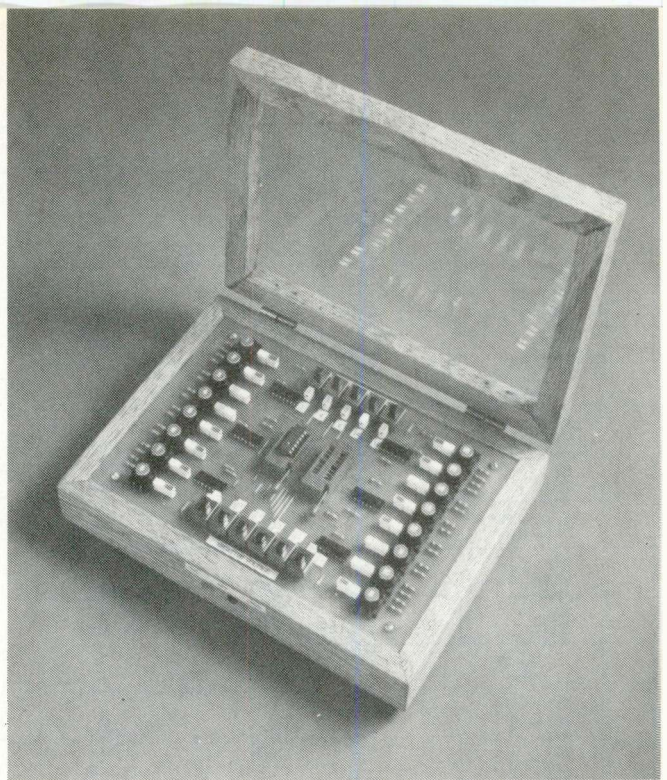

it's an output voltage from the CUT? Such a circuit would allow you to turn gates on and off, operate registers, apply pulses to counters, operate flip-flops, thereby enabling you to determine the merit of the chip merely by observing the output indicators.

Well the *Digi-lyzer Digital IC Tester* is just such a circuit, which, with the aid of a CMOS or TTL cookbook, any listed chip can quickly be tested. If that sounds like a handy thing to have around, hang in there—the best is yet to come.

About the Circuit

The circuit (see Fig. 1) is designed around two Zero-Insertion-Force (ZIF) integrated-circuit sockets to handle both 14 and 16 pin chips. The two sockets are wired in parallel so that any voltage presented to a particular pin on one socket appears at the same pin on the other (except 15 and 16 on the 14-pin socket). In other words, if +V is applied to pin 14 of SO1, pin 14 of SO2 will be at the same potential.

Each pin of the two ZIF sockets is normally grounded via pull-down resistors (R17 to R32). There are 16 pushbutton switches (PB1 to PB16, which correspond to pins 1 through 16), which are used to apply a logic high to its associated pin. Each of the ZIF sockets' pins are also connected to a double inverting-buffer stage, consisting of six 4049 CMOS hex inverting buffers, U1 through U6. When a pin is at logic low (ground or zero potential), the output of the first buffer goes high and lights the green LED (the even-numbered LED's up to 32), indicating a logic low on that pin. And when a pin has a logic high applied to it, the output from the second buffer goes high and lights the red LED, indicating a logic high (or voltage) on that pin. However, if a red LED lights while you are *not* holding the button down for that particular pin, the LED indicates a logic high output from the CUT. What could be simpler?

The slide switches, S1 to S11, provide a method by which you can cover the power requirements for all of the popular TTL and CMOS chip configurations. Positive voltage can be applied to pins 1, 4, 5, 14, and 16. A direct ground can be made available to pins 7, 8, 10, 11, 12, and 13. The pins with the direct positive and ground connections are indicated by

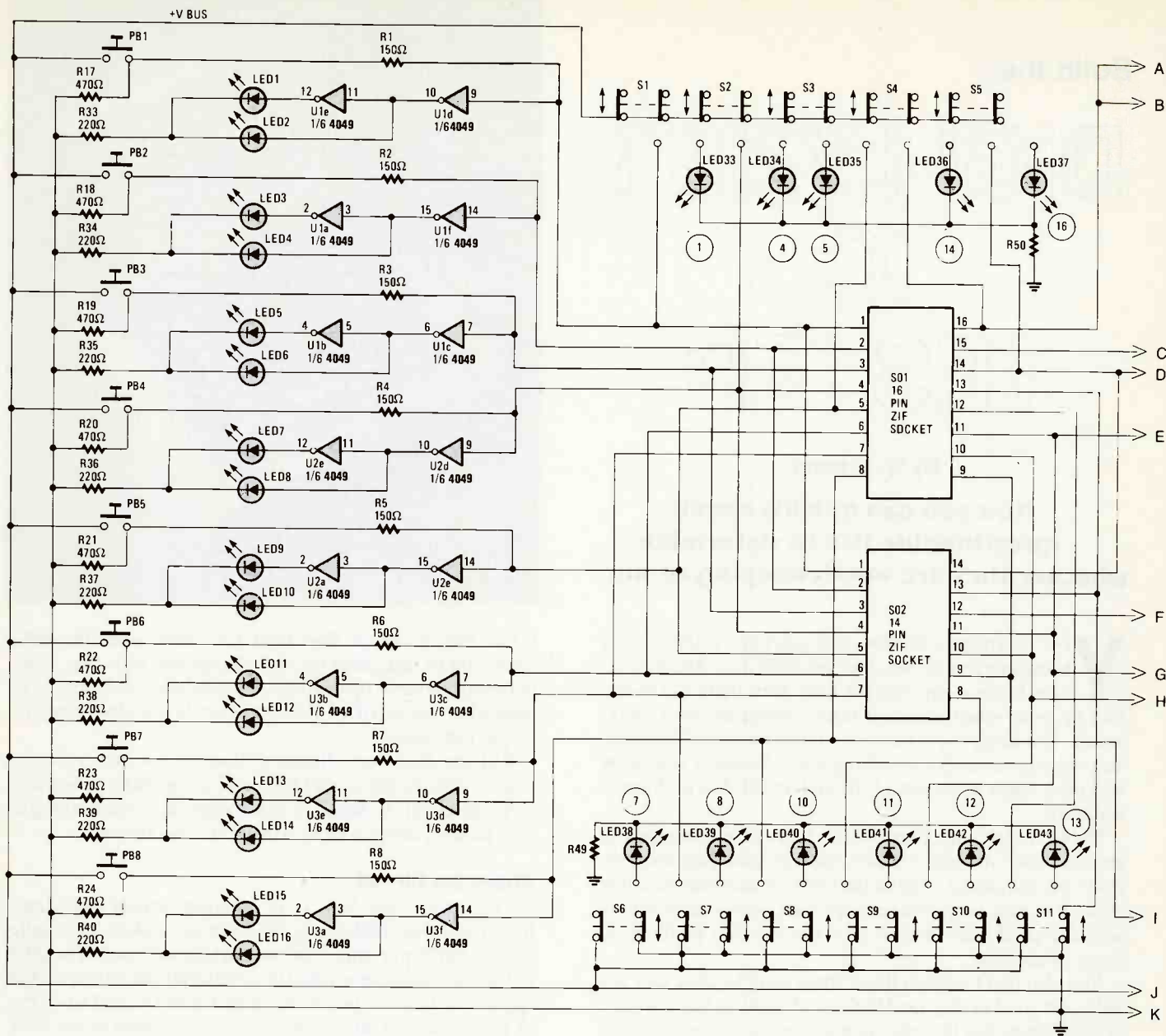

Fig. 1—The Digi-lyzer Digital IC Tester is designed around two zero-insertion force (ZIF) IC sockets wired in parallel. Each pin of SO1 and SO2 is normally grounded through pull-down resistors R17 to R32. Drawing continued on next page.

yellow LED's (LED33 to LED37 for +V and LED38 to LED43 for GND) located in front of each slide switch. Those LED's can be numbered with the pins they represent on the top of the printed-circuit board with a small typewritten number on a small piece of gummed label (see photos).

The chip is protected from possible damage by accidentally pushing a button and applying voltage to a directly grounded pin by series resistor (R1 to R16) connected between each pin of the sockets and the pushbutton switches. The circuit is powered by six ordinary "C" or "D" cell flashlight batteries.

The six batteries were split at 4.5 volts by inserting a piece of brass shim stock between the third and fourth battery from ground. Soldering a wire to the shim stock provides the 4.5 volt supply for checking TTL chips, while the 9-volt supply is used for checking CMOS chips. The two voltages are tied to a SPDT center-off, slide or toggle switch. Wired in that man-

ner, the switch provides the voltage selection and on-off function of the unit.

The author used eight "C" cells in his prototype, and wired them as shown in Fig. 2—which provides 4.5 volts for TTL chips and 12 volts for CMOS chips. Since CMOS chips have a much-wider power-supply range (typically from 3 to 15 volts) than do TTL units, the CMOS chips can be safely operated from the higher source voltage. Or a suitable dual-voltage AC-derived DC power supply can be developed and used to operate the Digi-lyzer as a bench model if desired.

Construction

The complete Digi-lyzer can be put together using the method of choice, but as always (well, almost always) it is recommended that the project be built on a printed-circuit board to simplify construction and virtually eliminate errors. Figure 3 shows a full-scale template of the Digi-lyzer's

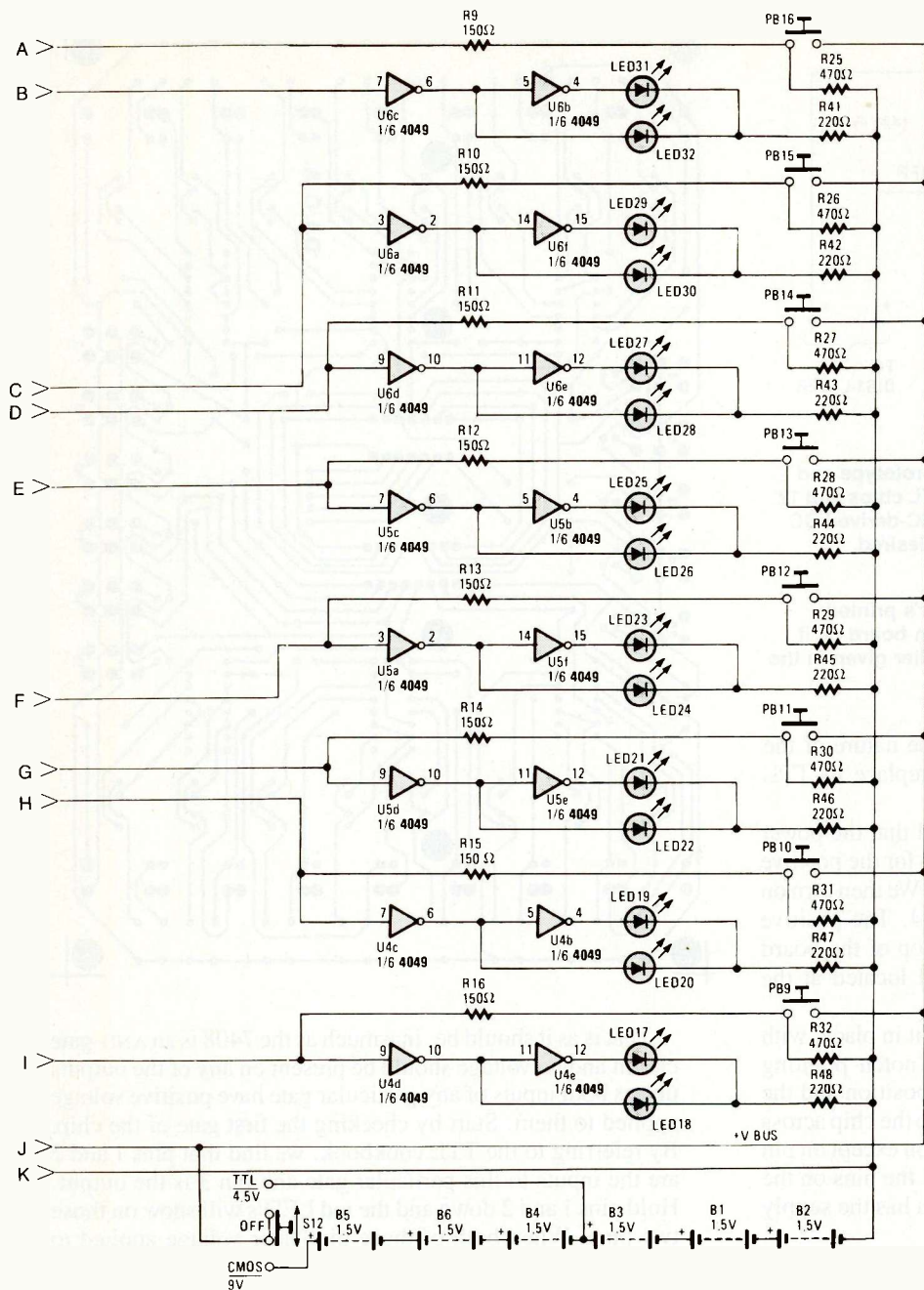

printed-circuit board. The board can be reproduced from the template or purchased from the supplier given in the Parts List that follows.

The large pads spaced lengthwise across the board are used to solder on a board stiffener (support), so that when you install a chip in the ZIF sockets or press a pushbutton switch, the board doesn't sag and possibly sever a trace or dislodge a solder connection.

The board stiffener can be made from a strip of PC-board material, cut to about 1/4-inch to 3/8-inch wide and as long as the distance between the two outside pads. Lay the strip in position across the pads and mark the location of each pad on the strip. At the pad-position markings on the stiffener, cut about 1/8-inch into the edge of the board to form a sort of stand off, and strip off the excess leaving the points where pads are indicated. When the strip is placed on edge, and soldered to all of the pads, it will stiffen the board so that it will not flex in the middle when the pushbuttons are pressed down. Be sure

that the strip does not touch anything else on the bottom of the board except the pads provided.

Next install the parts on the board, beginning with the jumper connections (see Fig. 4, the parts placement diagram) and passive components—resistors, capacitors and switches. The pushbutton switches (PB1 to PB16) on the prototype unit shown in the photographs were numbered with small round tabs glued to the top of the push buttons. They can also be numbered adjacent to the LED pair that each pushbutton controls. For simplicity, the arrangement order of the pushbuttons are in the same configuration as the pins are on the chip when it is put into the ZIF socket, (i.e., pin one at upper left corner).

Moving right along, install the LED's—red (even-numbered LED's up to 32) for +V, green (odd-numbered LED's up to 31) for ground, and yellow (LED33 to LED43) for the power connections. The LED's chosen for the author's prototype are small rectangular units available from many electronic parts suppliers (including mail-order supplier Jameco Electronics, 1355 Shoreway Rd., Belmont, CA 94002; Tel. 415/592-8097) in a variety of colors. Of course, you don't necessarily have to use that type of LED; the common garden-variety (refracted lens) can be used—it's the builder's choice and up to you.

You'll note that all of the LED's have their cathodes facing toward the center of the board. Since we are dealing with so many LED's (provided that you are using the square units), it is recommended that you mark the cathode end of the package, prior to installation (see photos), to allow for quick visual verification of proper orientation of the

LED's.

In the author's prototype, the integrated circuits were soldered directly to the board; however, it might be in your favor to use IC sockets, in the event that it becomes necessary to replace one or more of the chips. Finally, use either the Fig. 1 or Fig. 2 battery-wiring diagram to connect the power supply to the circuit.

Checkout Time

Once you've completed the unit and given it a visual inspection for possible trouble spots—such as solder bridges, cold-solder joints, misoriented components, and the usual battery of common construction defects—you can check out a few basic chips to get familiar with the Digi-lyzer's method of operation.

Let's start with a simple TTL quad two-input AND gate such as the 7408. That particular chip contains four two-input AND gates. Many of the TTL and CMOS chips share a

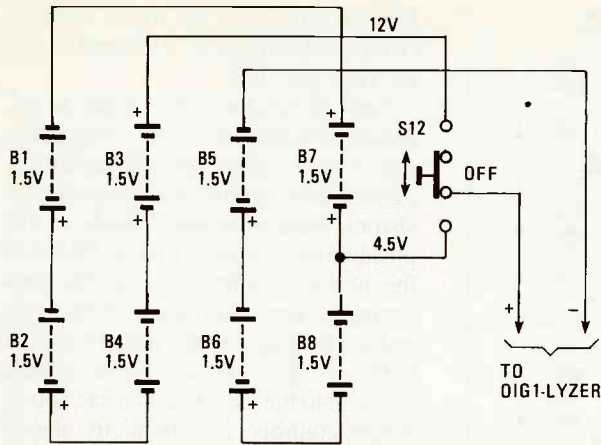
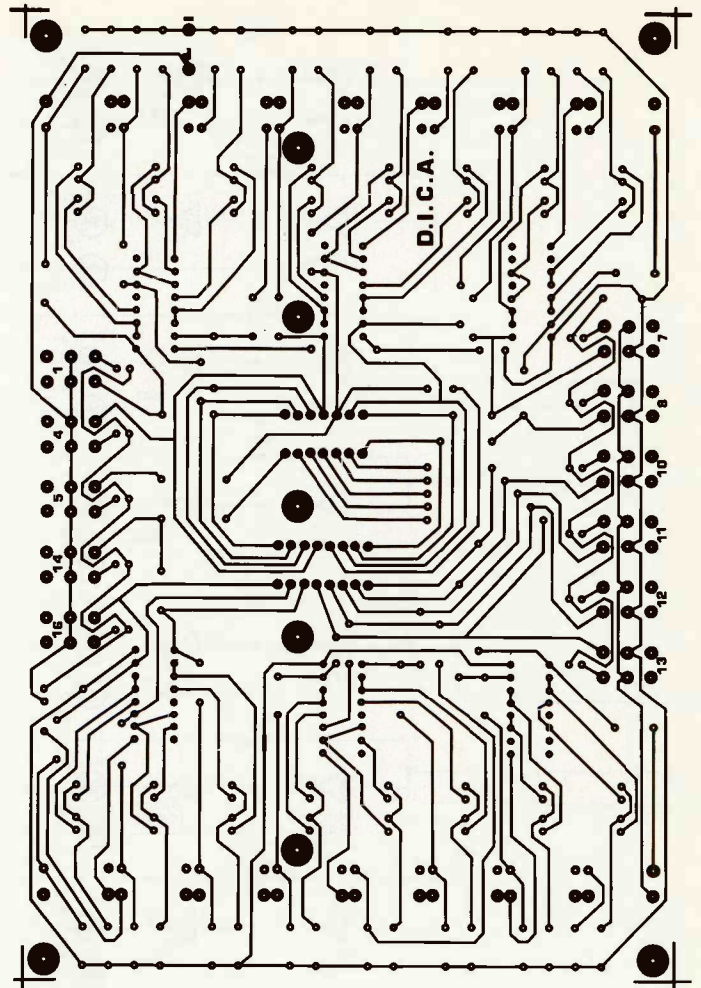

Fig. 2—The author used eight “C” cells in the prototype and wired them as shown to provide 4.5 volts for TTL chips and 12 volts for CMOS chips. A suitable multi-output AC-derived DC power supply can be used if a bench model is desired.

Fig. 3—This half-size template of the Digi-lyzer’s printed-circuit traces can be used to produce your own board or, if you prefer, it may be purchased from the supplier given in the Parts List. ▶



common pinout diagram. And because of the nature of the two logic families, the CMOS version can replace its TTL cousin, but rarely vice versa.

By looking at the TTL cookbook, we find that the power supply pins for that particular chip are pins 14 for the positive supply and pin 7 is the minus (or ground) pin. We then turn on the slide switches representing pins 7 and 14. The positive supply slide switches are all located at the top of the board while the minus or ground switches are all located at the bottom. We are now ready to test the chip.

Drop the chip into the ZIF socket and lock it in place, with pin 1 of the CUT in the upper-left corner (notch pointing upward). Turn the power switch to the TTL position and the yellow lights will show that power is applied to the chip across pins 7 and 14. All the green LED’s should be on except on pin 14, with a red LED lit. That indicates that all the pins on the chip are at ground potential, except 14, which has the supply voltage applied to it.

That is as it should be, inasmuch as the 7408 is an AND-gate circuit and no voltage should be present on any of the outputs unless both inputs of any particular gate have positive voltage applied to them. Start by checking the first gate of the chip. By referring to the TTL cookbook, we find that pins 1 and 2 are the inputs to this particular gate and pin 3 is the output. Hold pins 1 and 2 down and the red LED’s will show on those two pins. When both of those pins have voltage applied to them, pin 3 will also show a red LED indicating an output from the chip. If an output is seen without buttons 1 and 2 down, or no output is seen when those buttons are pushed down, that particular gate in that chip is defective. You can then check the other three gates in the package the same way. With the information provided on the operation of the chip from the TTL cookbook, and by observing the LED’s, you can either pronounce the chip sound and put it with your supply of good ones, or trash it. Either way, it’s out of the ash tray. One note of caution: When you are checking TTL chips, never switch the analyzer to the CMOS power-on position. The full 9 volts applied to a TTL IC will prematurely smoke a good chip.

Let’s take one more example. Suppose we are checking a CMOS CD4011. We set up the power pins on pins 7 and 14 just as before. We then drop the chip into the ZIF socket and

The author’s eight “C”-cell power source (shown here) was wired as shown in Fig. 2 to provide 4.5 volts for TTL chips and 12 volts for CMOS chips, which have a wider power-supply range than do their TTL counterparts.

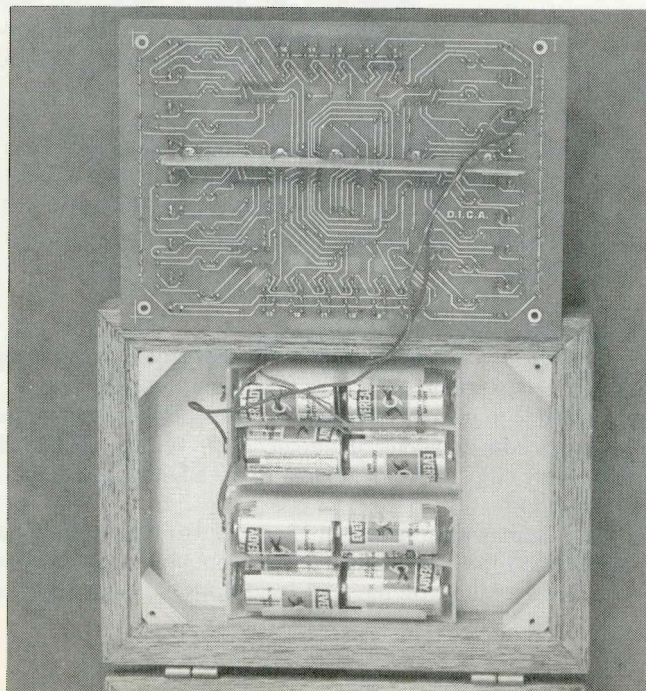

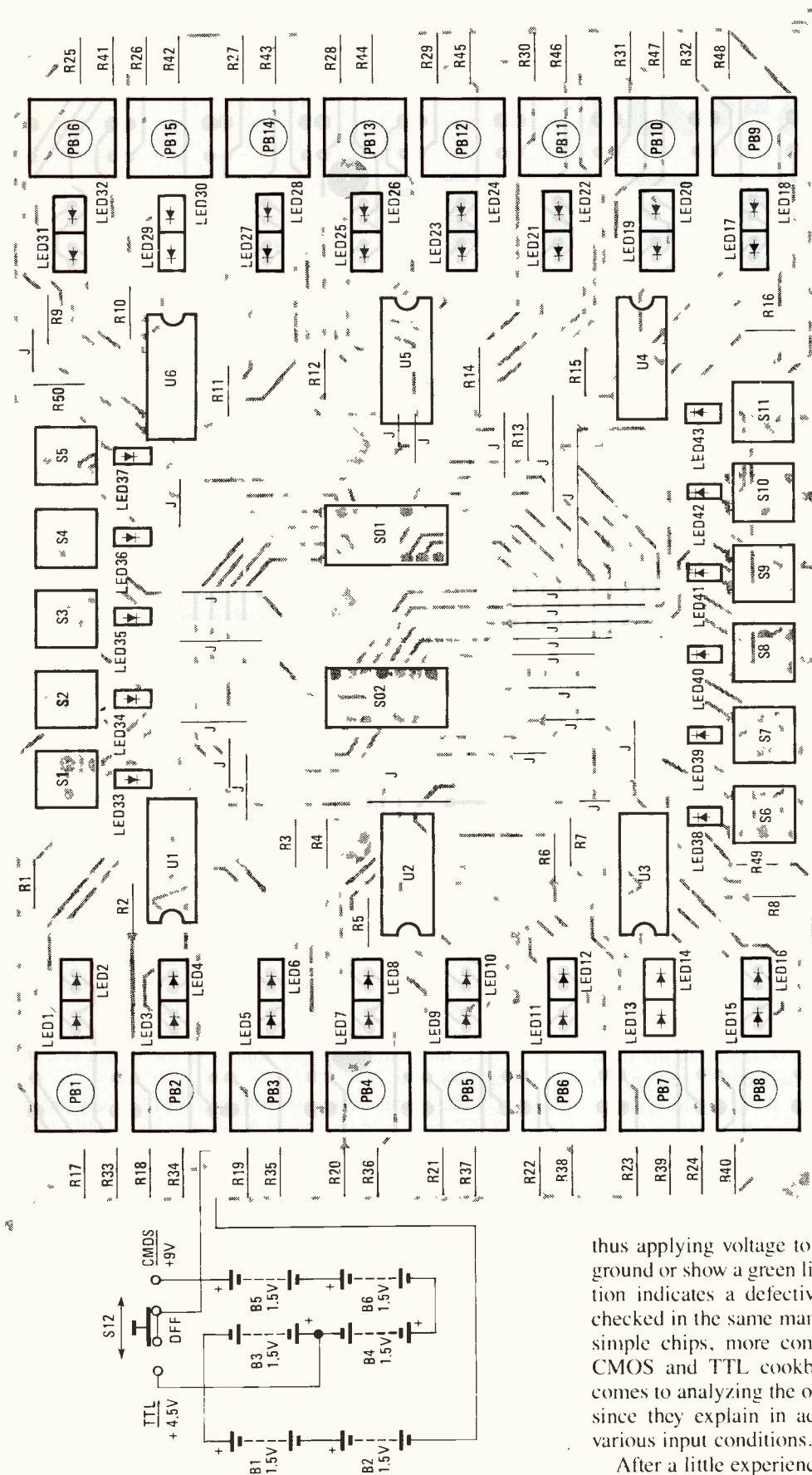

Fig. 4—Install the parts on the board using this parts-placement diagram as a guide. Begin with the connections and then the passive components—resistors, capacitors and switches. Next install the LEDs; red (even-numbered LED's up to 32) for +V, green (odd-numbered LED's up to 31) for ground, and yellow (LED33 to LED43) for the power connections.

lock it in place just as before. This time we switch the power on to the CMOS position, which applies the full 9 volts to the chip. This time we are checking a quad 2 input NAND gate. That is also a chip that has four such independent gates in one package. By referring to the CMOS cookbook, we see that on any one gate, with either or both inputs low, the output will be high. When the power is turned on, all the outputs will show voltage on them. That is just as it should be, because all the inputs are at ground potential. Checking the pin layout we find that the first gate has pins 1 and 2 as inputs and pin 3 is the output for one particular gate. By pushing down buttons 1 and 2, thus applying voltage to those pins, pin 3 should return to ground or show a green light. Any deviation from that operation indicates a defective gate. The other three gates are checked in the same manner. With a little experience on the simple chips, more complex chips can be analyzed. The CMOS and TTL cookbooks are invaluable aids when it comes to analyzing the operation of the more complex chips since they explain in advance what should happen under various input conditions.

After a little experience with the unit, you will be able to

(Continued on page 164)

Build the ... Hands-On Fishing Guide

By Tom Fox

**Nothing fishy about this project, it tells
you the water temperature that the fish like**

□Are you the type of fisherman who only gets to eat fish at the Red Lobster Restaurant or Long John Silver's Seafood Shoppe? Do you have that haunting feeling that the only fishing device that is at all effective was invented by Al Nobel, and is commonly called dynamite? If so, you may be interested in building a Hands-On Fishing Guide. While it won't catch fish, it will help "guide" you to where those tasty morsels with fins are likely to swim.

Once you decide upon which water to fish, the next problem is to locate the fish. That not only means where to park your boat, but at what depth to fish. To help solve the dilemma, the industry has deluged the market with fish finders of all types. Many are so sophisticated and expensive that one might think they were originally designed for the Stealth fighter! While the Hands-On Fishing Guide doesn't "find" fish, it does help one's gray matter figure out where the fish likely are—and it can be built for less than the cost of many non-resident fishing licenses!

What's It Do?

What the fishing guide does is measure the water temperature and locate that almost magical region called the *thermocline*. (Finding fish ain't the whole answer to fishin'—at times it seems you can dangle your hook in front of a zillion fish and never get a nibble. Lure, bait, weather, technique, timing etc., are also important.)

It has been found, for many types of fish, that the most productive depth to fish is in the thermocline region. To better understand the thermocline look at Fig. 1 which shows a cutaway view of a typical lake. During the summer (when most people fish) the warmest water is normally near the surface and the coldest water (near 39.2°F in deep lakes over 70 feet) is near the bottom. The warm top layer is known as the epilimnion. The temperature in that warm layer drops quite slowly with depth. Directly below that warm layer is a fairly narrow region called the thermocline. Here the temperature drops very rapidly (over 1°C per meter, 1.8°F per 3.2 feet). The thermocline is our target area, since most fish prefer that region. Below the thermocline is a cold region called the hypolimnion. There again, the temperature drops

slowly. In some lakes there are little or no fish in the bottom of the hypolimnion because there is little dissolved oxygen. The Hands-On Fishing Guide, which is described here, is a simple instrument that not only locates the thermocline region, but measures the water temperature and provides a mechanical means of determining the depth of the layers of water.

The LM335 Sensor

It was just over 10 years ago when the author first designed and built a thermocline indicator. The author's original instrument used matched thermistors since temperature sensor IC's were not widely available. The primary problem with matched thermistors is the amount of green stuff needed to get them. Now, with the availability of cheap temperature sensors, such as the LM335, the primary cost of the project described here is the cable that connects the sensor assembly to the circuit! (The author doesn't want to imply here that IC temperature sensors can take the place of thermistors in all applications. Generally, thermistors are more sensitive than the new sensors and some types are more rugged and less expensive.)

Basically, the LM335 functions as a zener diode whose zener voltage is linearly related to its temperature. Each .01-Volt corresponds to 1° Kelvin. Thus at 273°K (which is about 0°C or 32°F) the nominal output voltage of the sensor is 2.73 volts. Note that Kelvin degrees are the same "size" as Celsius degrees and that °K = °C + 273.16. Thus at 25°C the nominal output voltage of the sensor is a shade over 2.98 volts.

Unlike thermistors, two different LM335 sensors from two different manufacturer's batches have nearly identical

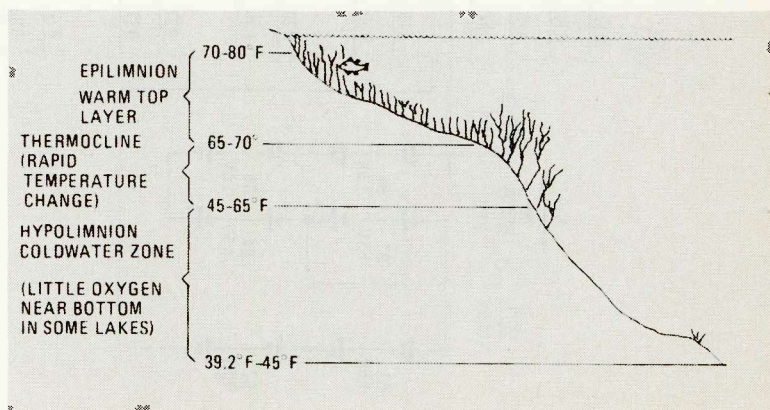

Fig. 1—Since fish get their oxygen from underwater plants, the often congregate around the layer of water that most of the plants grow in. That layer is the thermocline.



characteristics. The primary difference between one LM335 sensor and another is a small uncalibrated offset error. Once calibrated (with a simple pot) the sensors are, for all practical purposes, electrically identical. That feature is important in a thermocline indicator since it must detect small (1°K — 1°C — 1.8°F) differences in temperature.

Temperature Sensing

Referring to the schematic in Fig. 2, keep in mind that U4 is located 1 meter (3.28 feet) from U5. Under normal usage, U5 is cooler than U4 because it is in deeper water.

During initial calibration, U4 and U5 are at the same tem-

perature, and R1 is set so the voltage at TP1 equals the voltage at TP2. U1a and its associated resistors form a differential amplifier. That differential amplifier subtracts U5's voltage from U4's and then multiplies that difference by 100. That output voltage then goes to the noninverting input of U1b, which is connected as a voltage comparator. U1b's inverting input is connected to a circuit network consisting of the 2.5-volt precision reference U3 (LM336-2.5) and a voltage divider. Resistor R2 is adjusted so 1 volt appears on U1b's inverting input. The output of the voltage comparator drives voltage-follower buffers U1c and U1d, which provide driving current for LED11 and BZ1, respectively.

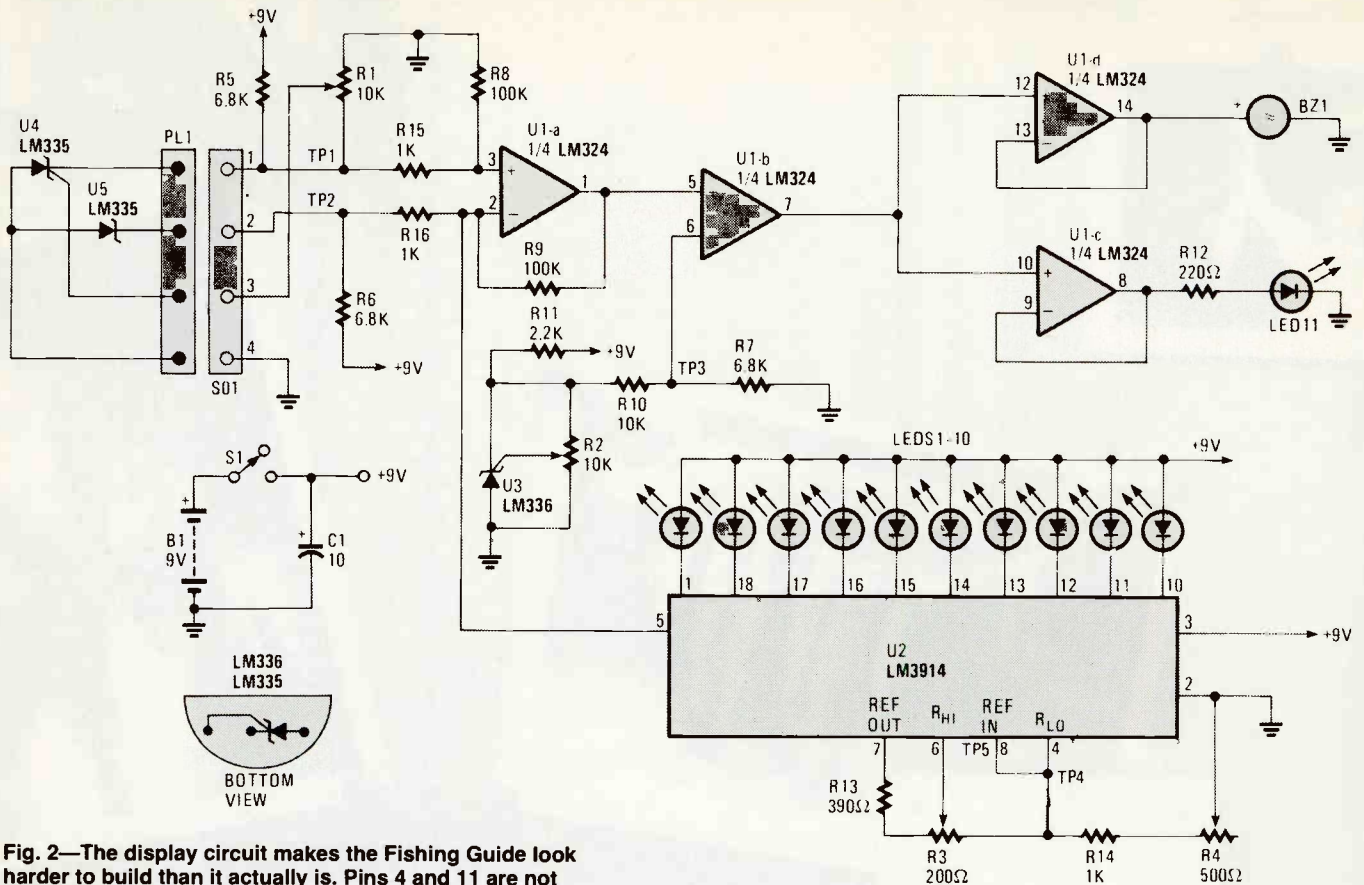

Fig. 2—The display circuit makes the Fishing Guide look harder to build than it actually is. Pins 4 and 11 are not shown for U1 as they are the power leads.

As you can see, when the probe first encounters a thermocline (greater than a 1°K difference between U4 and U5), the output of U1a rises above 1 volt (100 × .01). Since U1b's noninverting input voltage is now greater than the 1 volt at its inverting input, it switches on, lighting LED11 and sounding the alarm.

The Display

Now, we will describe how the temperature-measuring circuit provides its output. As can be seen from the schematic, we make use of the LM3914 dot/bar display driver (U2). That IC not only simplifies things tremendously, but it allowed us to design a surprisingly inexpensive instrument.

Simply put, the input signal from U5 is connected to pin 5. The lowest voltage which turns on the first LED (connected to pin 1) is applied to R_{lo} at pin 4. The highest reference voltage (at which level the 10th LED turns on at pin 10) is connected to R_{hi} at pin 6. The other LED's turn on at signal levels between R_{hi} and R_{lo} .

The LM3914 has a built-in floating 1.25-volt reference source. Since it is floating (not internally connected to ground) that internal reference can be used to be an effective 1.2- to 12-volt reference. (That fact is not intuitive, but it does come out in the math and in practice, trust me. Of course the reference source can only produce a 12-volt reference voltage with a supply voltage over 12 volts.)

Resistor R3, in Fig. 2, effectively acts as a "temperature-range" control, and is set for a voltage difference of .27 volts between TP4 and TP5. Resistor R4 is set so that LED1 just comes on when U5 is in a mixture of ice and water. (Or alternately, R4 is set for a voltage of 2.71 volts at TP4.) Remember, LED1 turns on in the 32-37°F range of temperatures. When R4 is set properly, the voltage at R_{lo} is approxi-

mately 2.71 volts, which of course means the voltage at R_{hi} is 2.98 volts (2.71 + .27), which corresponds to a temperature of 77°F.

One Step Further

The following may be of interest for those readers who enjoy learning the intricacies of a circuit. Note that with most sensors, R4 will be set for a reference voltage at pin 4 of 2.71 volts. By referring to the simplified schematic in Fig. 3, notice that there is a 1.25-volt potential between pins 7 and 8 (pins 4 and 8 are connected together). To simplify things assume that I_{adj} is zero—in practice it is extremely small, so that assumption is a good one. Referring to Fig. 3 and using $I = V/R$, it should be clear that the current flowing through R3 is:

$$1.25 \div 590 = 2.118644 \text{ mA}$$

Since we assume $I_{adj} = 0$, that current through R3 also flows through R4 and produces a voltage of 2.71 volts. In order for this to take place, since $R = V/I$, R4 must be:

$$2.71 / .002118644 = 1279 \text{ ohms}$$

which we can see in Fig. 2, is the resistance of the series combination of R14 and R4, with R4 set to near its midpoint.

Construction

While the simplicity of this project does permit point-to-point wiring, a printed circuit board simplifies construction. All parts, except the switch and sensors, can be mounted on this board. The foil pattern for this project is given in Fig. 4 and the component layout is shown in Fig. 5. Note that NO circuit board jumpers are used—a definite indication of circuit simplicity. Use a 14-pin, DIP IC socket for

PARTS LIST FOR THE HANDS-ON FISHING GUIDE

SEMICONDUCTORS

LED1-LED10—Clear, high-efficiency, light-emitting diode
 LED11—Green, high-efficiency light-emitting diode
 U1—LM324N, quad operational amplifier IC
 U2—LM3914, dot/bar display driver IC
 U3—LM336Z-2.5 2.5-volt reference diode
 U4, U5—LM335 Precision temperature sensor

RESISTORS

(All resistors are 1/4-watt, 5% units except where otherwise indicated.) R1,R2—10,000-ohm, vertical-mount, trimmer potentiometer
 R3—200-ohm, 15-turn, trimmer potentiometer
 R4—500-ohm, vertical-mount, trimmer potentiometer
 R5,R6—6800-ohm
 R7—6800-ohm, 1% precision
 R8,R9—100,000-ohm, 1% precision
 R10—10,000-ohm, 1% precision
 R11—2200-ohm
 R12—220-ohm

R13—390-ohm
 R14—1000-ohm
 R15,R16—1000-ohm, 1% precision

ADDITIONAL PARTS AND MATERIALS

B1—9-volt, alkaline battery
 BZ1—9 to 12-volt, solid-state buzzer
 C1—10 μ F, 25 WVDC, tantalum or electrolytic capacitor
 PL1—4-conductor plug, Digi-key part #A1430, with pins ϕ A1422
 S1—SPST slide switch
 SO1—4-conductor socket, Digi-key part #A1431, with sections #A1423

Circuit board, 4-conductor cable, heat-shrink tubing, heat-shrink capsules, case, press-on vinyl decorative sheet, dry transfer lettering, IC sockets, silicone rubber, hardware, solder, etc.

U1 and an 18-pin, DIP IC socket for U2. (If 18-pin, IC sockets aren't available, you can cut two pins off a 20 pin IC socket or solder U2 directly to the board.) The points marked TP1, TP2, etc. are test-points, and a short piece of bare wire (or a piece of clipped excess component lead) should be inserted in these holes for easy testing.

The wires marked 1, 2, 3, and 4 should be connected to their respective socket connections at the end of the 8-10-inch long, 4-conductor cable. The other end of the short cable is connected to the board. The author used a 4-conductor, 'Amp mate-n-lok, free hanging connector. The wiring of SO1's mate, PL1, will be described in the next section.

While the author used clear orange LED's for LED1 through LED10 and a green LED for LED11, the reader should feel free to choose other colors. Nonetheless, clear, high efficiency (bright) LED's should be used to provide maximum visibility in sunlight. The author mounted the LED's to the foil side of the board. That allowed the author to mount the circuit board closer to the front panel. Though a piezoelectric buzzer is recommended for BZ1, any low-current 9 to 12-volt buzzer can be used. Battery B1 should be a 9-volt alkaline battery (NEDA 1604A or equivalent).

Sensor Assembly

Refer to Fig. 5, which shows the details of sensor assembly. Note that a 4-conductor cable is required and that the two sensors are separated by 1 meter (3', 3'-3/8"). The length of this cable depends upon the depth of the water you'll be using the project in—normally from 20 to 100 feet.

Since this assembly is used in water, it *must be waterproofed*. Unless you have previously successfully waterproofed sensors, follow the directions in Fig. 6 carefully.

If you have difficulty in locating heat-shrinkable sensor capsules, you can make your own. Figure 7 displays how

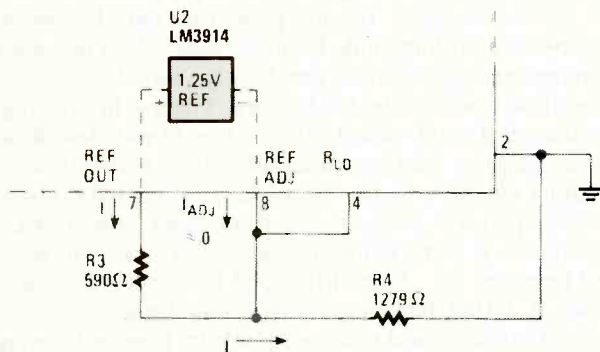

Fig. 3—This simplified schematic for the range-adjustment circuit of U2 should make clear the reasons for choosing the parts used in the real circuit. However, note that R3 and R4 do not correspond to the values of those resistors in the real circuit. They are presented only for illustration.

Fig. 4—Use this page and a photo-resist method to prepare your board. Take care to clean up any sloppy traces, as some of them are very close together.

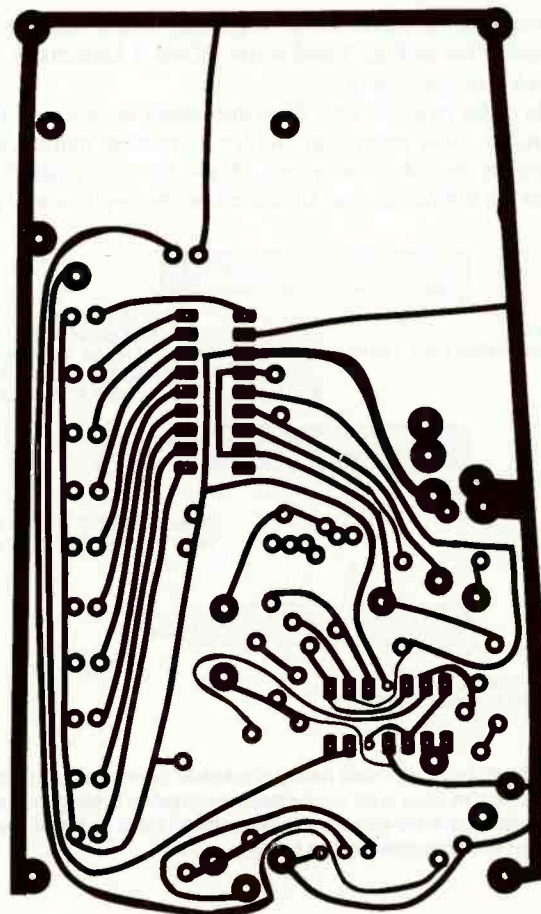

Fig. 5—The LED's are repositioned for direct mounting onto the board. That means the case you put the project in must accommodate the board close to its face.

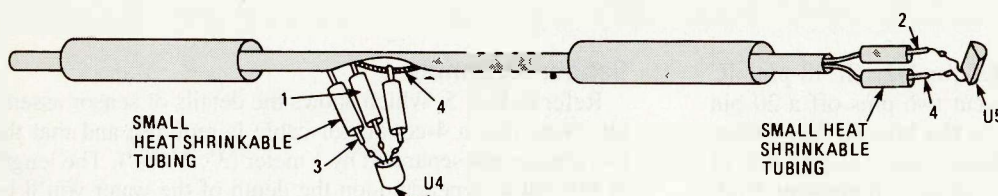
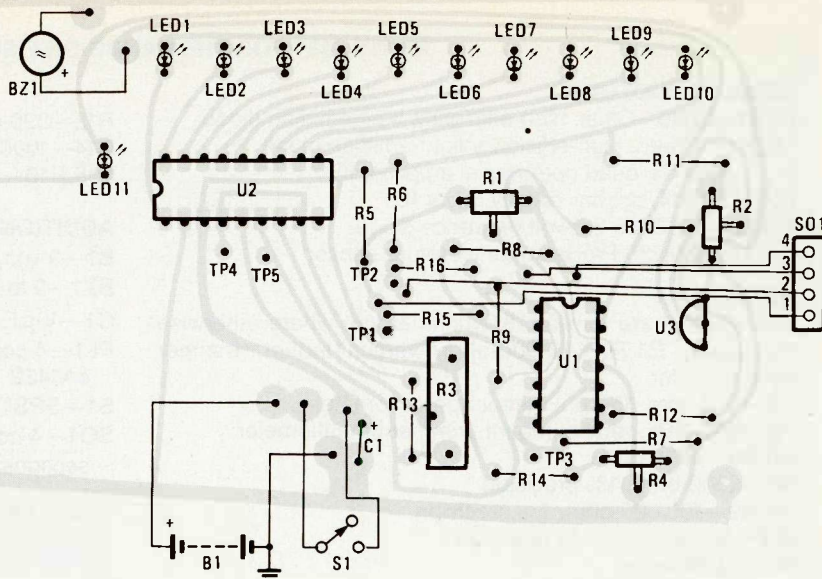
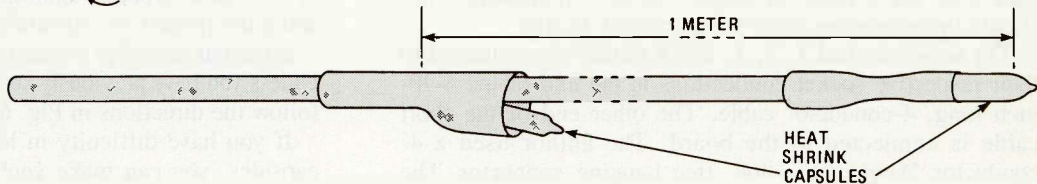

Fig. 6—Be careful not to heat the IC's too much while shrinking the tubing to water-proof them. Also be sure to use heat shrinkable tubing of a small enough size to tighten securely around the components.



to make home-made sensor capsules. When silicone rubber is called for in Fig. 5 and 6 use "Dow's Gaskets in a Tube Black" or equivalent.

In order to know how deep the sensor is, you will need to mark the cable every foot. With a permanent marker, make a mark on the cable every foot. Make the first mark 2-1/2 feet from the bottom sensor. To determine the depth, simply count

the marks when dropping or pulling up the sensor.

The unconnected end of this cable must be wired to a connector in SO1 that mates correctly with PL1. The author connected the cable's wires to the pins that fit in a 4-conductor pin housing.

Cabinet and Panel Assembly

For the cabinet, the author used a 6 x 3-3/16 x 1-7/8" plastic case that is available from any electronic parts distributor. Use a 3/16" drill for the LED holes. Make sure you use very little pressure when drilling the holes in the plastic. If available, use a drill press. The foil pattern (or bare PC board) can serve as a drilling guide for those holes. Also provide a mounting space on the front panel for the switch.

The front panel can be made more attractive by applying a weatherproof vinyl "Sport-Stik," a type of waterless decal with an adhesive backing. After all drilling was complete, the author cut out a portion of model 12-R (COHO) Sport-Stik and applied it to the plastic front panel. (Sport-Stik's are available at many hardware and variety stores, or write The Meyercord Co., Dept. PHC, 365 E. North Ave., Carol Stream, IL 60187. Include 25 cents in coin for a color booklet. For the professional look, use black dry transfer lettering that is available in office supply stores as well as through electronic parts dealers.

The circuit board can be mounted directly to the front panel with 3 or 4, 1", 6-32 machine screws, nuts, and lock-washers. At least one 5/8" spacer (or washers) is required

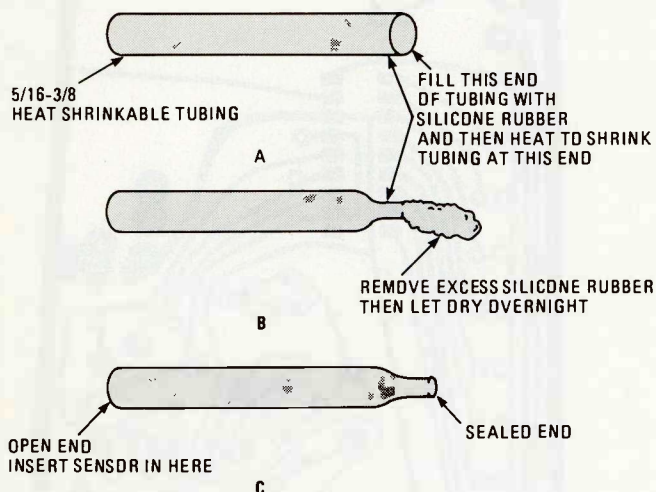

Fig. 7—If you can't find heat shrinkable capsules, you can make you're own with some heat shrinkable tubing and silicon in a tube. Be sure you don't use enough heat to harm the silicon while shrinking the tubing.

between the board and front panel. Using a small round file, make a small rounded indentation in the top of the case for the cable to come through between the case and front panel.

Calibration

Have available a pail of cool water and install a new 9-volt alkaline battery in the unit. Place both sensors in the pail of water and stir periodically for at least 5 minutes. Connect the negative lead of a digital voltmeter (a good quality analog voltmeter can also be used) to circuit ground. Measure the voltages at TP1 and TP2 and adjust R1 until the two voltages are equal. (An even better way of accomplishing the same thing is to adjust R1 until the voltage difference between TP1 and TP2 is less than 0.000.) With the voltmeter's negative lead still connected to ground, connect the positive lead to TP3. Adjust R2 for a reading of between .99 and 1.000 volt. (With ideal components the voltage of TP3 should be set to exactly 1 volt. However, since three-dimensional, real-life parts are used, it may be necessary to change this setting slightly. (See the next section on preliminary testing and re-calibration.)

Next, connect the negative lead of the voltmeter to TP4 and positive lead to TP5. Adjust R3 for a .270-volt reading. The final calibration can be done with two different methods; the voltmeter or the *icy finger* method (using ice cubes). The voltmeter method is slightly less accurate—typically $\pm 3^\circ\text{F}$ for the voltmeter method versus $\pm 1^\circ\text{F}$ for the "icy finger" method. However, since few fish are into thermometry, extreme accuracy here isn't really essential. For the voltmeter method, again connect the voltmeter's negative lead to circuit ground. Next connect the positive lead to TP4 and adjust R4 for 2.71 volts.

For the icy finger method, place both sensors into a bucket that contains 1/2 ice cubes and 1/2 water. After waiting about 5 minutes, adjust R4 so the LED1 just barely goes on (*make sure LED2 doesn't turn on*).

Preliminary Testing

Before taking your Hands-On Fishing Guide on a fishing trip you probably will want to test it out under simulated conditions. For that test you will need two buckets of water and at least one accurate thermometer—two accurate thermometers are preferred. Half-fill both buckets with water in the 60-70°F range and make a note of the temperature of the water in each bucket. Assuming both temperatures are nearly identical, add enough hot water to one bucket so as to raise its water temperature exactly 2°F above the water in the other bucket. Place U5 (the sensor at the end of the cable) in the cold water and U4 in the warm water. Wait at least three minutes. The thermocline alarm should go on and the LED's should indicate the correct temperature range. If after five minutes the thermocline alarm and thermocline LED do not go on, carefully adjust R2 until they do.

Using the Fishing Guide

When fishing, one should attach what is called a *depth sounder* to the end of the cable. A depth sounder—not to be confused with electronic sonar devices sometimes also

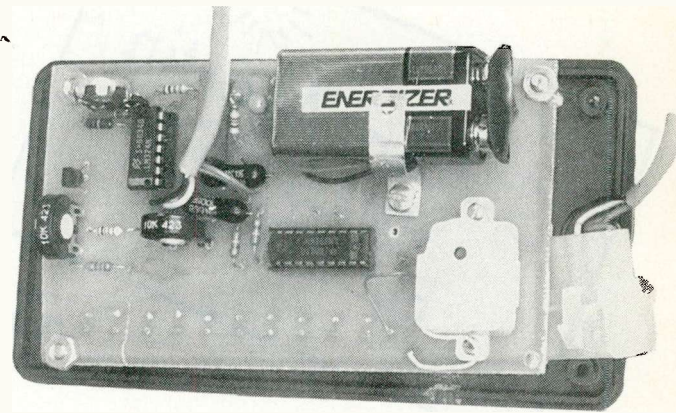

referred to as depth sounders—which are available in most sporting goods stores and bait shops, is simply an alligator clip with a leaded weight. If you wish, you can make one yourself with an alligator clip and molten solder.

When lowering the sensor assembly into the water make sure you do it very slowly or you'll miss weak thermoclines. As the sensor sinks into the water you will notice that different LED's will light, indicating lower and lower temperatures. Assuming it is summer, the buzzer and thermocline LED should go on. When it does, you know the sensors

(Continued on page 158)

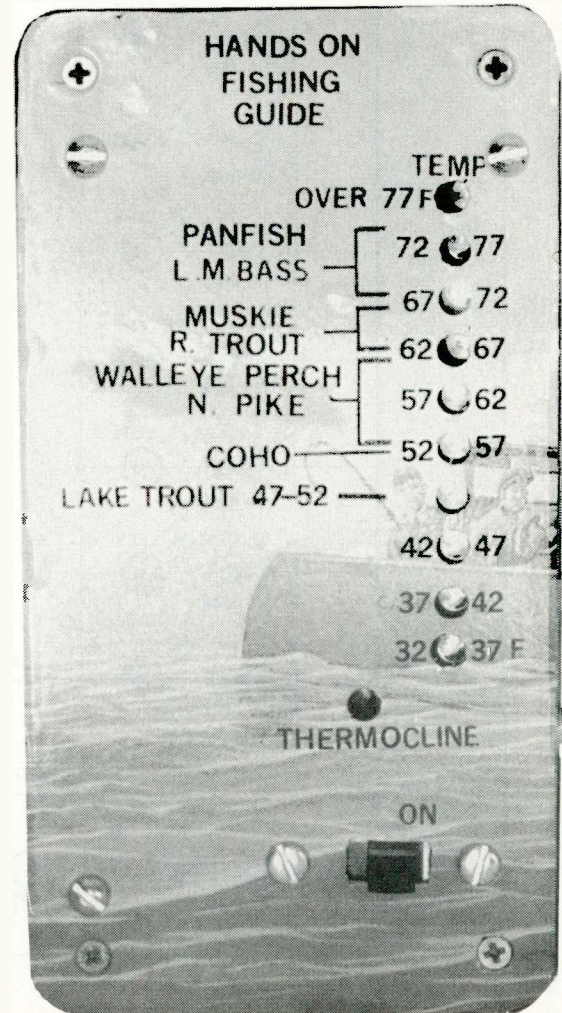

Using precut lettering gives the Fishing Guide a professional look. The author included the names of fish next to the temperatures of water they like to inhabit.

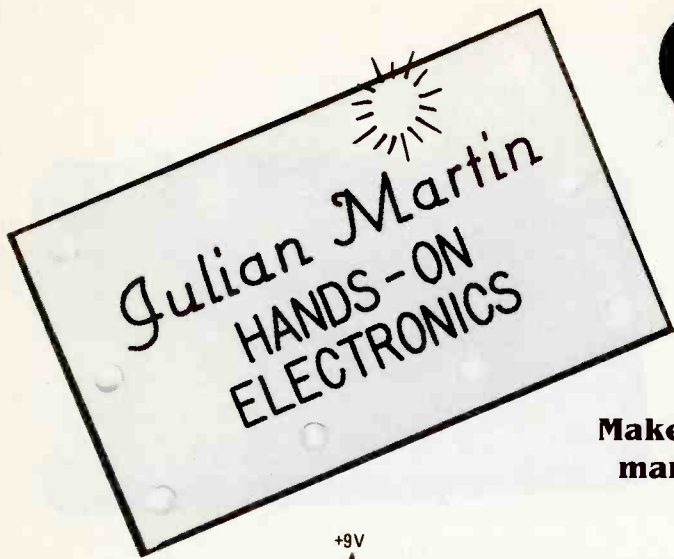

GEE WHIZ BADGE

By W. Schopp

Make your statement to the world on a badge with marquee chase lights rotating around the edge

IF YOU HAVE A STATEMENT TO MAKE, AN IDEA TO PRESENT, or a product to sell, there is no better way than to put it on a badge, stick it in your lapel, and exhibit it to the world. Private clubs, small and large industries, fund raisers, and even politicians use them. The big problem is that badges are so common, no one ever takes notice or reads them anymore. At least, that was the case.

The badge, with its lights traveling around the edge is destined to change all that. It will definitely stand out among all other badges. It is a great conversation starter, and it will also make you very easy to locate in a dimly lit room. The badge has no other socially redeeming features other than to cause the casual observer to exclaim, "Gee whiz!" Thus, its name the *GEE WHIZ Badge*.

How It works

Figure 1 shows the schematic diagram of the GEE WHIZ Badge. The circuit consists of a simple decade counter, (U1), with all of its outputs driving LED's through 4049 inverting buffers, (U2, and U3). The two buffer chips contain twelve buffers, only ten are required to drive the LED's, the remaining two are used to form a squarewave generator, which in turn, is used to drive the counter.

The ten decoded outputs of the counter (U1) are then fed through an equal number of inverting buffers to drive the LED's. By driving the LED's with a buffer, a full turn-on is accomplished, making the LED's flash quite brightly. Since only one LED is on at any given moment, one current-limiting resistor is shared by all the LED's.

As each output of the counter goes high (one at a time), the buffer output goes low, removing the reverse bias that had been applied to the cathode of the LED. The LED, now forward-biased, will glow momentarily; after which, the next counter output goes high (while the previous one goes low), turning on the next LED in the sequence. That sequence continues until all ten LED's have been lit and then the sequence starts all over again.

The frequency of the generator as shown is around two cycles per second (2-Hz to modern-day whiz kids). It can be sped up or slowed down to suit individual taste by changing the RC time constant of the oscillator (i.e., increasing or decreasing the values of C2 and R3). Power for the circuit is

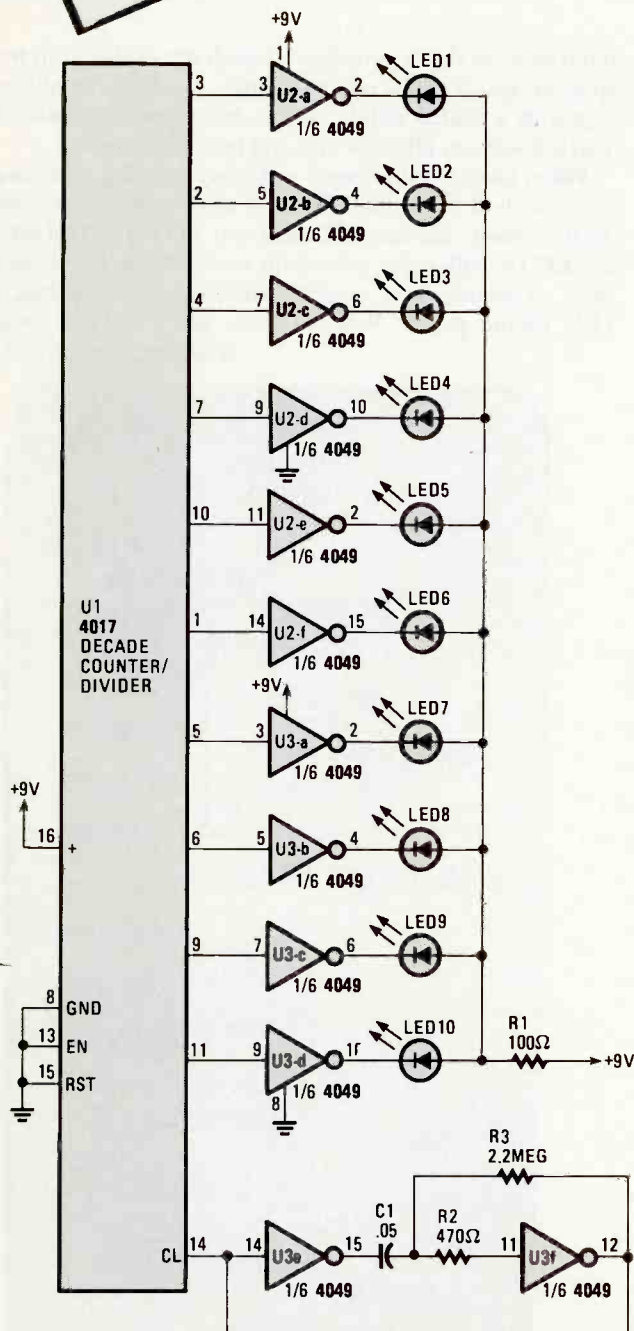
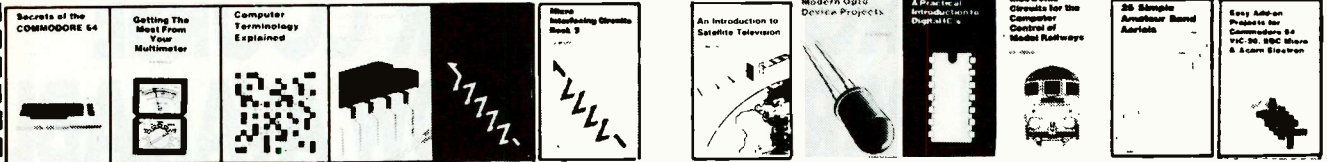

Fig. 1—The schematic diagram of the GEE WHIZ Badge shows that the circuit consists of a decade counter, (U1), with all outputs driving LED's through hex inverting buffers U2, and U3.

Electronics Paperback Books

GREAT ELECTRONICS PAPERBACKS FROM ETT



- BP195—INTRODUCTION TO SATELLITE TV..... \$9.95.** A definitive introduction to the subject written for the professional engineer, electronics enthusiast, or others who want to know more before they buy. 8 x 10 in.
- BP128—20 PROGRAMS FOR THE ZX SPECTRUM AND 16K ZX82.....\$5.75.** Included with each program is a flow chart and a description of what happens. Notes for converting programs for use on other computers are also included.
- BP235—POWER SELECTOR GUIDE.....\$10.00.** Complete guide to semiconductor power devices. More than 1000 power handling devices are included. They are tabulated in alpha-numeric sequence, by technical specs. Includes power diodes, Thyristors, Tracs, Power Transistors and FET's.
- BP234—TRANSISTOR SELECTOR GUIDE.....\$10.00.** Companion volume to BP235. Book covers more than 1400 JEDEC, JIS, and brand-specific devices. Also contains listing by case type, and electronic parameters. Includes Darlingtion transistors, high-voltage devices, high-current devices, high power devices.
- BP99—MINI-MATRIX BOARD PROJECTS.....\$5.50.** Here are 20 useful circuits that can be built on a mini-matrix board that is just 24 holes by ten copper-foil strips.
- BP157—HOW TO WRITE ZX SPECTRUM AND SPECTRUM + GAMES PROGRAMS..... \$4.95.** A crystal-clear step-by-step guide to writing your own graphics games programs.
- BP117—PRACTICAL ELECTRONIC BUILDING BLOCKS—Book 1.....\$5.75.** Oscillators, Timers, Noise Generators, Rectifiers, Comparators, Triggers and more.
- BP184—INTRO TO 68000 ASSEMBLY LANGUAGE.....\$6.95.** The 68000 is a great new breed of microprocessor. Programming in assembly language increases the running speed of your programs. Here's what you need to know.
- BP179—ELECTRONIC CIRCUITS FOR THE COMPUTER CONTROL OF ROBOTS \$7.50.** Data and circuits for interfacing the computer to the robot's motors and sensors.
- BP126—BASIC & PASCAL IN PARALLEL.....\$4.95.** Takes these two programming languages and develops programs in both languages simultaneously.
- BP198—AN INTRODUCTION TO ANTENNA THEORY...\$6.95**
Basic concepts relevant to receiving and transmitting antennas.
- 225—A PRACTICAL INTRODUCTION TO DIGITAL IC'S.....\$5.25.** Mainly concerned with TTL devices. Includes several simple projects plus a logic circuit test set and a digital counter timer.
- BP170—INTRODUCTION TO COMPUTER PERIPHERALS.....\$5.95.** Shows how to use a variety of co computer add-ons in as non-technical a way as possible.
- 227—BEGINNERS GUIDE TO BUILDING ELECTRONIC PROJECTS..... \$5.50.** How to tackle the practical side of electronics so you can successfully build electronic projects.
- BP169—HOW TO GET YOUR COMPUTER PROGRAMS RUNNING.....\$5.95.** Shows how to identify error in program and what to do about them.
- BP194—MODERN OPTO DEVICE PROJECTS.....\$6.25.** Crammed with great projects for the experimenter. Includes sections on Fiber optics, passive Infra-Red detectors, plus an assortment of miscellaneous projects..
- BP180—ELECTRONIC CIRCUITS FOR THE COMPUTER CONTROL OF MODEL RAILROADS..... \$7.50.** It's easy to interface home computers to model railroad control. The main problem is in interfacing the computer to the system.
- BP110—HOW TO GET YOUR ELECTRONIC PROJECTS WORKING.....\$5.75.** How to find and solve the common problems that can occur when building projects.
- BP239—GETTING THE MOST FROM YOUR MULTIMETER..... \$5.95.** Covers basics of analog and digital meters. Methods of component testing includes transistors, thyristors, resistors, capacitors and other active and passive devices.
- BP36—50 CIRCUITS USING GERMANIUM, SILICON & ZENER DIODES.....\$5.50.** A collection of useful circuits you'll want in your library.
- BP37—50 PROJECTS USING RELAYS, SCR'S & TRIACS.....\$5.00.** Build priority indicators, light modulators, warning devices, light dimmers and more.
- BP39—50 FET TRANSISTOR PROJECTS.....\$5.50.** RF amplifiers, test equipment, tuners, receivers, tone controls, etc.
- BP42—SIMPLE LED CIRCUITS..... \$5.50.** A large selection of simple applications for this simple electronic component.
- BP127—HOW TO DESIGN ELECTRONIC PROJECTS.....\$5.75.** Helps the reader to put projects together from standard circuit blocks with a minimum of trial and error.
- BP122—AUDIO AMPLIFIER CONSTRUCTION.....\$5.75.** Construction details for preamps and power amplifiers up through a 100-watt DC-coupled FED amplifier
- BP92—CRYSTAL SET CONSTRUCTION.....\$5.50.** Everything you need to know about building crystal radio receivers.
- BP45—PROJECTS IN OPTOELECTRONICS..... \$5.50.** Includes infra-red detectors, transmitters, modulated light transmission and photographic applications.
- BP48—ELECTRONIC PROJECTS FOR BEGINNERS.... \$5.50.** A wide range of easily completed projects for the beginner. Includes some no-soldering projects.
- BP49—POPULAR ELECTRONIC PROJECTS..... \$5.95.** Radio, audio, household and test equipment projects are all included.
- PCP104—ELECTRONICS BUILD AND LEARN \$9.95;** starts off with construction details of a circuit demonstrator and shows a variety of circuits for experimenters.
- BP56—ELECTRONIC SECURITY DEVICES.....\$5.50.** Includes both simple and more sophisticated burglar alarm circuits using light, infra-red, and ultrasonics.
- BP59—SECOND BOOK OF CMOS IC PROJECTS.....\$5.50.** More circuits showing CMOS applications. Most are of a fairly simple design.
- BP72—A MICROPROCESSOR PRIMER.....\$5.00.** We start by designing a small computer and show how we can overcome its shortcomings.
- BP74—ELECTRONIC MUSIC PROJECTS.....\$5.95.** Provides the experimenter with a variety of practical circuits including a Fuzz Box, Sustain Unit, Reverberation Unit, Tremelo Generator and more.
- BP91—AN INTRODUCTION TO RADIO DXING..... \$5.50.** How you can tune in on those amateur and commercial broadcasts from around the world in the comfort of your home.
- BP94—ELECTRONIC PROJECTS FOR CARS AND BOATS.....\$5.50.** Fifteen simple projects that you can use with your car or boat. All are designed to operate from 12-volt DC supplies.

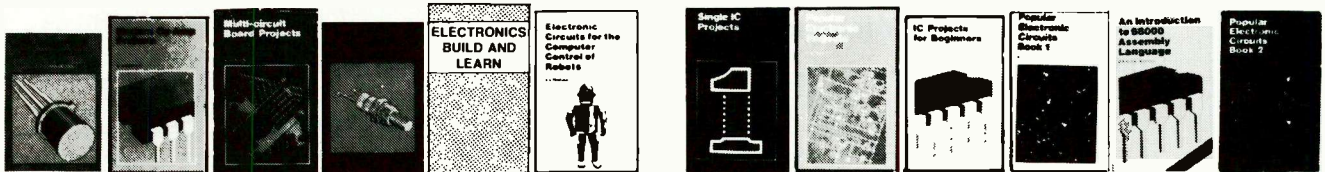

ELECTRONIC TECHNOLOGY TODAY INC.
P.O. Box 240, Massapequa Park, NY 11762-0240

**SHIPPING CHARGES IN
USA AND CANADA**

**SORRY No orders accepted
outside of USA & Canada**

Number of books ordered

Name _____
Address _____
City _____ State _____ Zip _____

\$0.01 to \$5.00	\$1.25
\$5.01 to 10.00	\$2.00
\$10.01 to \$20.00	\$3.00
\$20.01 to \$30.00	\$4.00
\$30.01 to \$40.00	\$5.00
\$40.01 to \$50.00	\$6.00
\$50.01 and above	\$7.50

Total price of merchandise \$ _____
Sales Tax (New York State Residents only) \$ _____
Shipping (see chart) \$ _____

All payments must be in U.S. funds
Total Enclosed .. \$ _____

PEH89

EIA/CEG AUGMENTS DIGITAL AND MICROPROCESSOR COURSE HIGH TECH PARTS KITS NOW AVAILABLE

The members of the Electronic Industries Association Consumer Electronics Group (EIA/CEG) through the Product Services Committee, has marketed the illustrated parts kit for vocational schools, educators and technicians. This is the same material used in the Digital and Microprocessor Course during EIA's summer workshop programs. These workshops are organized by the Consumer Electronics Group and co-sponsored by national service organizations and state departments of vocational education.

Parts and components are contained in a lightweight tool box with individual compartments. It includes a breadboard, power supply, pre-dressed jumpers, resistors,

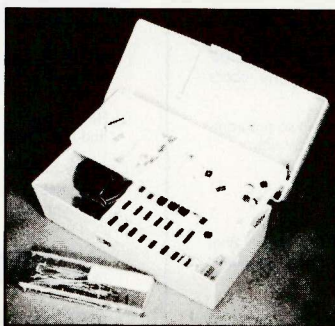
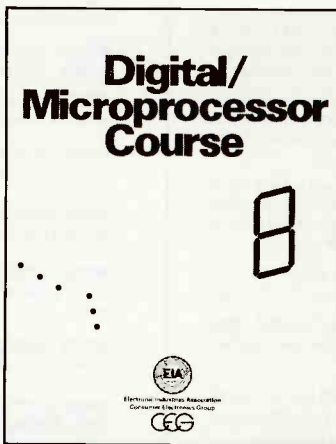

capacitors, and integrated circuits to perform all digital exercises 1 through 25 of the Digital/Microprocessor course book listed in the table of contents. Some parts have been included for the microprocessor section but other components will have to be acquired (as listed in the Introduction to Exercises 26-31).

Individual and classroom size quantities are available at the following cost: quantities 1-9, \$69.95 each, quantities 10-19, \$67.95 each, and for quantities 20 or more, \$64.95 each (cost includes shipping and handling). The kits will also include the Digital and Microprocessor Course book. Additional books are available at the cost of \$2.00 per copy.

PLEASE COMPLETE ORDER FORM FOR PARTS KITS AND BOOKS

Send to: EIA/CEG, Department PS, P.O. Box 19100, Washington, D.C. 20036

ORDER FORM

Parts Kit	Quantity	Amount	Total
1-9	_____	\$69.95 each	_____
10-19	_____	\$67.95 each	_____
20 or more	_____	\$64.95 each	_____
Additional Digital/Microprocessor Course Books	_____	\$2.00 per copy	_____
Total Amount Enclosed			_____

Name																	
Title																	
Firm																	
Address																	
City											State			Zip			

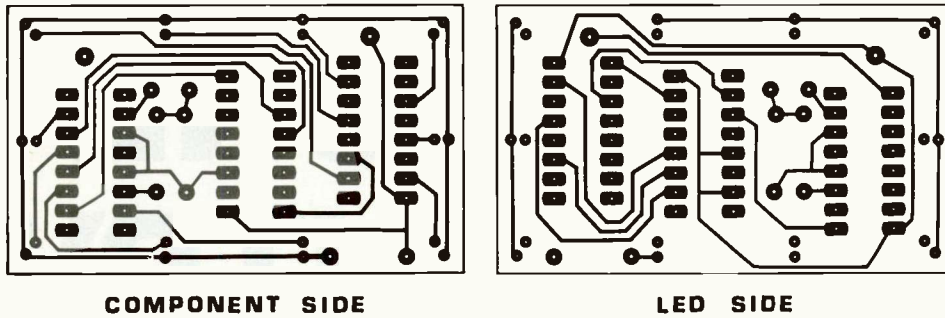

Fig. 2—The printed-circuit traces of the GEE WHIZ Badge's double-sided, printed-circuit board are shown full-scale. If you decide to do everything from scratch, use the IC pads to align the two PC board traces. You can avoid that bothersome chore by purchasing the kit of parts from the supplier given in the Parts List.

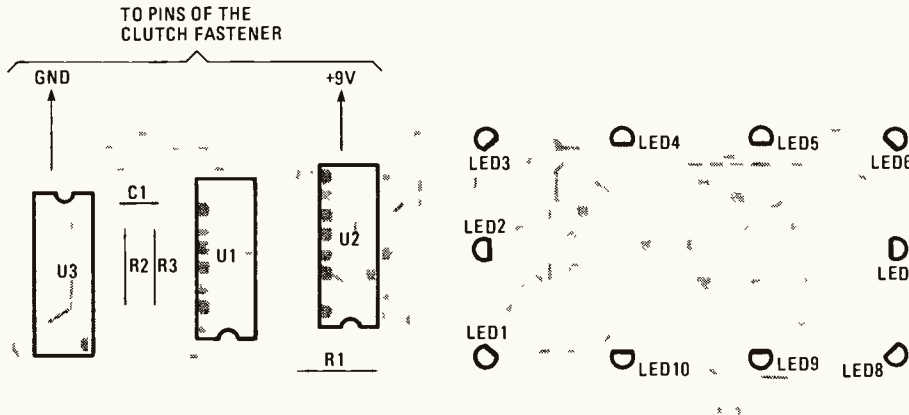

Fig. 3—Note that this parts-placement diagram shows that all of the parts (except the LED's) are mounted on the component side of the printed-circuit board (A). Soldering the components on both sides of the board eliminates the need for plate-through holes. The LED's are mounted flush against the opposite side of the board (B) and because of the short lead length, care must be taken when soldering so as not to overheat the LED's.

provided by an ordinary 9-volt transistor-radio type battery, which is easily concealed inside a shirt, vest, or coat pocket. The GEE WHIZ Badge is constructed on a double-sided, printed-circuit board. The PC traces for both sides of the board are shown in Fig 2. Datum points are also provided for proper alignment of the two sides of the board, which are identified on the printed-circuit pattern as *component side* and *LED side*.

By soldering the components on both sides of the board, plated-through holes can be avoided. All the components, except the LED's, are mounted on one side of the board and the LED's are mounted on the other side (as shown in Fig. 3A and Fig. 3B). The LED's are mounted flush against the printed-circuit board and because of the short lead length, care must be taken
(Continued on page 160)

PARTS LIST FOR THE GEE WHIZ BADGE

- U1—CD4017 decade counter/divider, integrated circuit
- U2, U3—CD4049 hex inverting buffer, integrated circuit
- C1—0.05- μ F, ceramic disc capacitor
- R1—100-ohm, 1/4-watt, 5% resistor
- R2—470-ohm, 1/4-watt, 5% resistor
- R3—2.2-Megohm, 1/4-watt, 5% resistor
- LED1—LED10—Light-emitting diode, T1 size

ADDITIONAL PARTS AND MATERIALS
Double-sided printed-circuit board (see supplier below),

9-volt transistor-radio battery, battery clip, badge plastic, clutch clips, small-gauge (flexible) hookup wire, etching solution, solder, etc.

Note: A kit of parts containing GEE WHIZ Badge's double-sided, printed-circuit board, two plastic badges pre-drilled for T1 LED's, and two clutch badges with clips is available (postpaid) in the USA and Canada for \$12.50 from Electronic Enterprises, 3305 Pestana Way, Livermore, CA 94550. Please allow 6 to 8 weeks for delivery

Fig. 4—Battery connections to the Badge are made via clutch-clip pins (available from any engraving shop), which are epoxied to the tops of U2 and U3. The positive and negative power leads are then brought up from the board and soldered to the base of the pins, and battery leads are then soldered to the clutch clasps that engage the pins.

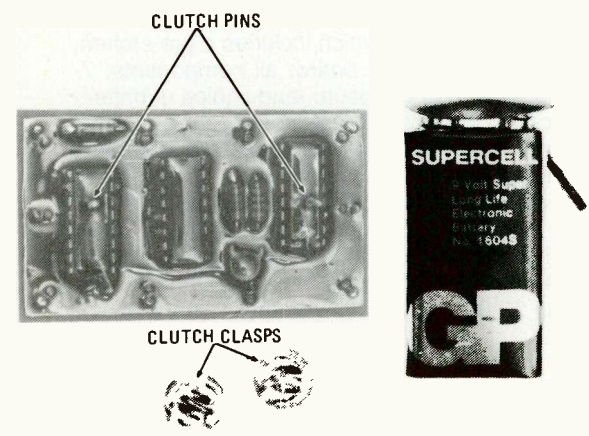
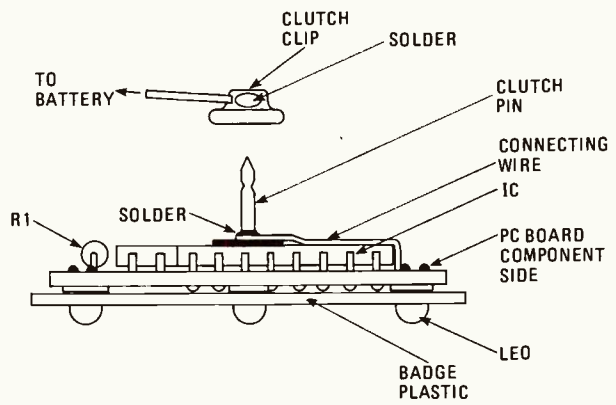

When assembled, the component side of the printed-circuit board becomes the back of the Badge. Because power is supplied to the circuit via the clutch pin/clasp assembly, it's recommended that the +V pin and clasp be marked with a dab of red nail polish so that power is not inversely applied.

PHONE SENTRY

By Luther M. Stroud

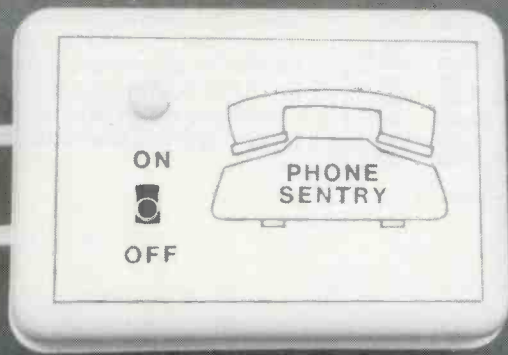

Daysleepers or professional persons on-call, defend yourself from nuisance calls with this call screener

TELEMARKETING PROFESSIONALS SUBJECT THE UNSUSPECTING consumer to a barrage of telephone sales pitches. The day-sleeping shift worker has three options; disconnect the phone, use a recording machine, or (most displeasurable of all) answer the phone. The first two options will certainly protect your sleep; but if you are a professional person, who is on-call, you *must* answer the phone. Still, you need not concern yourself with being disturbed by "junk" calls if you build and install the *Phone Sentry*.

The Phone Sentry, with a minimum of cost and complexity, works on the premise that callers of low priority hang up after about six rings or less. Thus, what the Phone Sentry does is allow the user to program the number of rings of an incoming call that must occur before your telephone is allowed to ring. Although Phone Sentry is not a cure-all for disturbing phone

calls, it certainly can help protect the sleeping person from wrong numbers, sales pitches, and the most impersonal of them all, telemarketing computers.

How it Works

Figure 1 shows the Phone Sentry's schematic diagram—a rather simple circuit comprised of four integrated-circuit chips and a handful of assorted support components. Placing S1 in the "on" position applies power to the circuit and places R1 in series with one side of the line going to your telephone. That inhibits an incoming ring signal from activating the bell in the phone, but allows the circuitry to sense when the handset is lifted to make an outgoing call.

A fullwave-bridge rectifier is formed by D9–D12, with its positive output being applied to the cathode of D13. The bridge ensures that the voltage applied to D13 is always

PARTS LIST FOR THE PHONE SENTRY

SEMICONDUCTORS

D1–D8—1N914 small signal diode
D9–D12—1N4004 1A, 200-PIV rectifier diode
D13—12-volt ½-watt, Zener diode
LED1—Light-emitting diode (optional, see text)
Q1—2N2222A general-purpose NPN transistor
U1—CD4013B dual, D-type flip-flip, CMOS integrated circuit
U2—CD4538B dual, monostable-multivibrator, CMOS integrated circuit
U3—CD4040B binary counter, CMOS integrated circuit
U4—4N36 or 4N37 optoisolator/coupler, integrated circuit

RESISTORS

(All resistors are ¼-watt, 5% units unless otherwise noted.)

R1—47,000-ohm
R2–R4—10,000-ohm
R5, R6, R9—100,000-ohm
R7—680,000-ohm
R8—330,000-ohm
R10—1000-ohm (optional, see text)

ADDITIONAL PARTS AND MATERIALS

C1—.01-μF ceramic disc

C2, C3—10-μF, 16-WVDC electrolytic
I1—6-volt subminiature incandescent lamp (optional, see text)
K1—Reed relay, (PC-mount) 5-volt coil (RS 275-232)
S1—Double-pole, double-throw (DPDT) miniature PC mount slide switch
Printed-circuit board, suitable enclosure, wire, solder, battery and battery holder or AC adapter, hardware, etc.

The following is available from Pershing Technical Service, PO Box 1951, Ft. Worth, Texas 76101: A kit of parts priced at \$30.00, which includes a pre-etched, pre-drilled printed-circuit board; all components; 7-foot modular cable; enclosure, and choice of battery holder or AC adapter. Please specify which power source when ordering. In addition, the following items are available separately: printed-circuit board only at \$12.00; component-parts kit with printed-circuit board \$24.00; enclosure \$3.00; modular telephone cable \$4.00; 6-volt AC adapter \$4.50. Quoted prices include postage and handling for USA orders. Canadian orders add \$2.00. Please allow from 6 to 8 weeks for delivery.

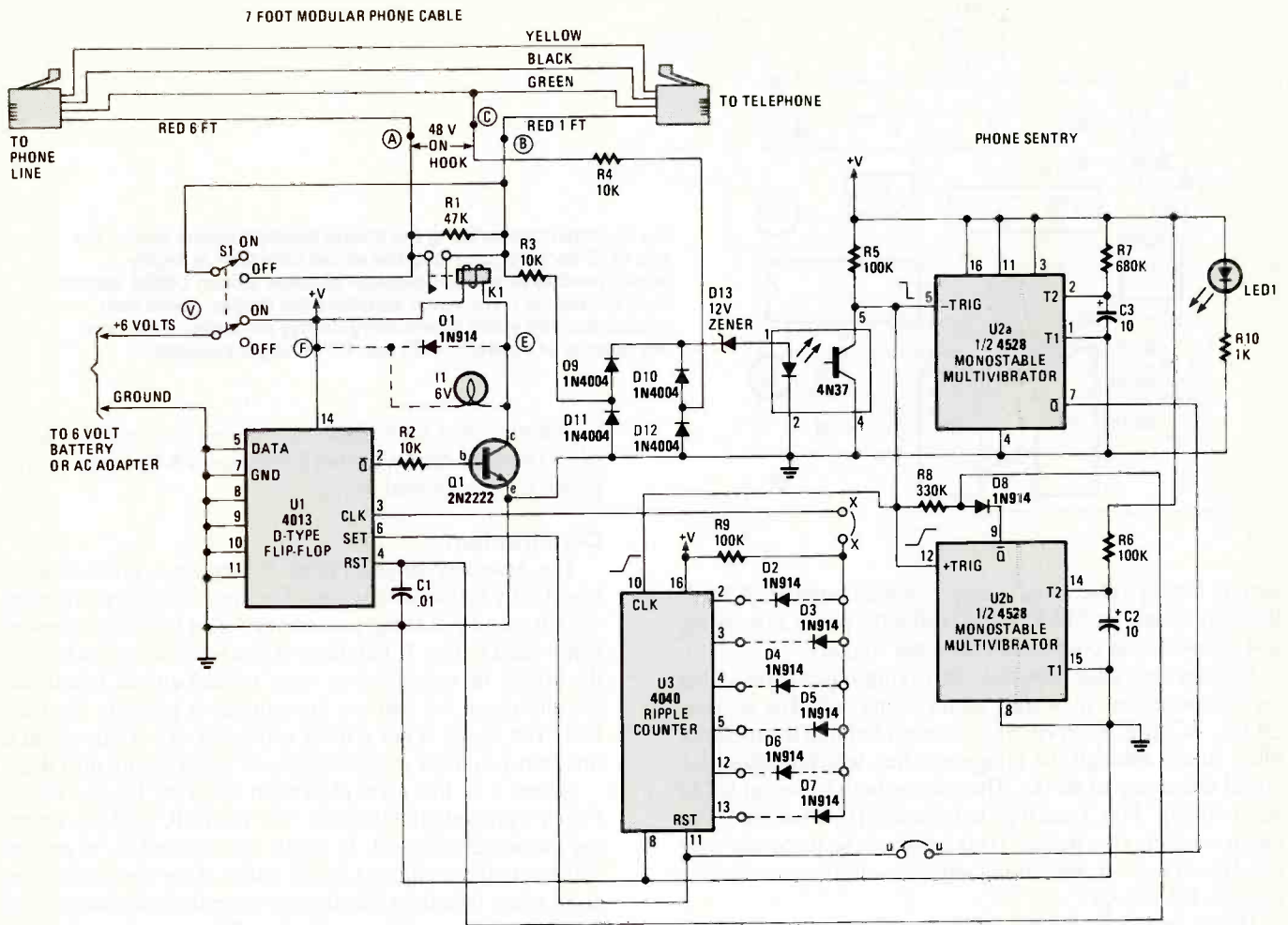

Fig. 1—The Phone Sentry project is a rather simple circuit comprised of four integrated-circuit chips and a handful of assorted support components. A fullwave-bridge rectifier—formed by diodes D9–D12—with the telephone on-hook, applies 10 volts across D13, which enables optocoupler U4, and causes the voltage at pin 5 to drop to near ground potential.

positive, without regard to the telephone-line polarity. Resistors R3 and R4 maintain the balance of the line and limit current through U4, a 4N37 optoisolator/coupler.

With the telephone on hook, 10 volts appears at the cathode of D13, causing current to flow through the LED within U4, enabling it and causing the voltage applied to pin 5 by R5 to be near ground level.

Now let's assume that an outgoing call is to be made. The phone's receiver is lifted, causing a voltage drop across R1. The forward bias is removed from D13 and U4 turns off. Pin 5 of U4 rises to the positive supply rail. That positive-going transition is fed to pin 12 of U2b (half of a 4528 dual monostable multivibrator, set for a timing cycle of 1–2 seconds). Its purpose is to allow relay K1 to close and remain closed when making an outgoing call. The relay closes after U2b completes its timing cycle.

Now let's assume that the outgoing call is completed and

the receiver of the telephone is hung up. Pin 5 of U4 returns to a logic "0" level. That negative transition, when sensed at pin 5 of U2a, triggers that multivibrator, starting its 7- to 10-

Fig. 2—The assembly of the Phone Sentry on printed-circuit board is, by far, the easiest way of putting the project together. This full-scale template is provided for those who prefer to roll their own. For those not inclined to the rigors of etching your own circuit board and chasing down the parts, a kit supplier is given in the Parts List.

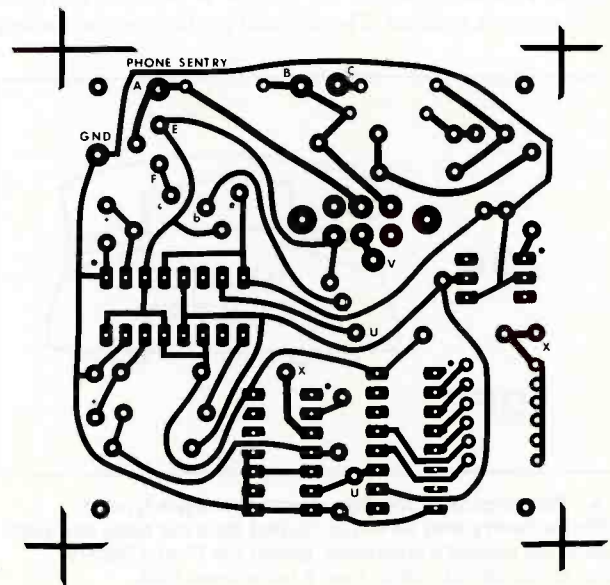

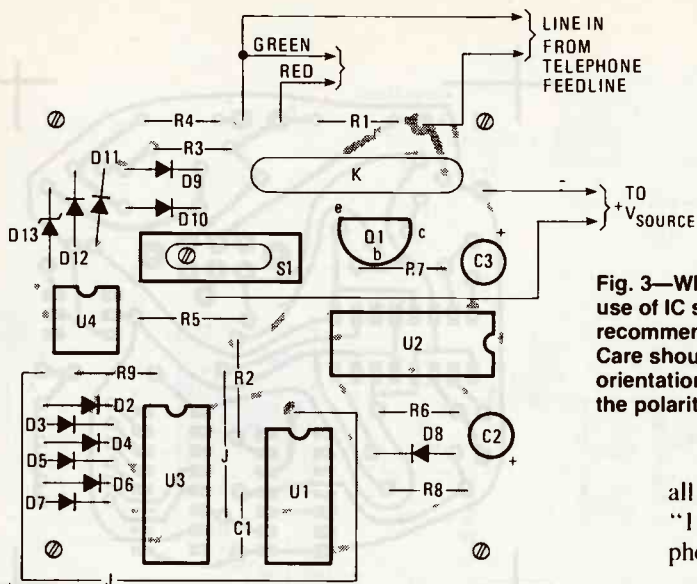

Fig. 3—When assembling the Phone Sentry's circuit board, the use of IC sockets (inserting the actual chip last) is highly recommended to prevent damage to those silicon CMOS wafers. Care should be taken when installing the diodes—note their orientation and avoid overheating during soldering. Also note the polarity of capacitors C2 and C3 during installation.

all outputs, that have diodes connected to them, are logic "1." This then clocks U2 pin 3 and closes K1's contacts. The phone is now allowed to ring.

Construction

The assembly of the Phone Sentry on a printed-circuit board is by far the easiest way of putting this project together. And to speed you along your merry way, a full-scale template is provided in Fig. 2. For those of you who are not inclined to the rigors of etching your own printed-circuit board and chasing down the parts, a kit supplier is given in the Parts List. The layout is not critical and perfboard construction is fine, but you must work carefully to avoid wiring mistakes.

Figure 3 is the parts-placement diagram for the Phone Sentry's printed-circuit board. The use of IC sockets, inserting the actual chip last, is highly recommended, to prevent damage to those silicon CMOS wafers. Care should be exercised when installing the diodes—note their orientation and avoid overheating during soldering. Also note the polarity of C2 and C3 during installation. Note that in the schematic diagram, incandescent lamp *Il* or diode D1 (shown in dotted lines) are optional; you should use one or the other, as in the author's prototype.

The lamp is used as a nightlite, illuminating the telephone, while indicating that an extension phone is in use. If it is not used in your project, a diode should be installed at points marked E and F on PC board foil-side with the banded, or cathode, end of the diode going to F. That prevents an inductive voltage spike from damaging Q1. LED1 and R10 are also optional and are intended to indicate power is supplied from an AC wall adapter.

Power requirements without LED1, R10, and L1 are about 20 mA with the relay energized and a small fraction of 1 mA standby. The author left space in the enclosure for a battery holder and 4 AA batteries. They should last several months, depending on telephone use and if the Phone Sentry is turned off when not needed.

A four-conductor modular phone cable is prepared by carefully cutting away some of the outer insulation (about one foot from one end), without damaging the internal wires. Cut the red and green wires, leaving the other two wires intact. Install both green wires to point C on the printed circuit board. The red wire, going to the long end of the cable, is installed to point A and the other red wire to B. A mistake here will keep your project from working.

Figure 4 shows the logo for the author's prototype type of the Phone Sentry. The logo may be cut or copied from the

(Continued on page 160)

second timing cycle. That serves a twofold purpose: It holds the relay closed for 7 to 10 seconds after the phone is hung up, and allows U3 to count. U2b does not trigger.

Now let's see what happens when a ring signal is presented on the phone line, indicating an incoming call. The 90-volt, 20-Hz, AC ring signal enters the circuit through the modular plug, travels through the bridge rectifier, which doubles the signal frequency to 40 Hz. That causes both halves of U2 to begin timing. Pins 7 and 9 go to logic level 0, allowing U3 to begin counting ring pulses. U1 is inhibited, so its Q output (at pin 2) is at logic 0, preventing any base-emitter current flow through R2 and Q1.

Under those conditions, Q1 is turned off, the relay (K1) contacts remain open, and the telephone is not allowed to ring. Capacitor C1, connected to pin 4 of U1, prevents the short pulse that occurs between the time U2b is triggered and pin 9 goes low from toggling U1a. All that is needed now is a clock pulse from U3, along with a few associated components, to toggle U1 and close the relay.

Integrated circuit U3 is programmed to count ring pulses by connecting diodes D2-D7 to form a multiple input AND gate that provides a logic "0" output at point X until the desired count is reached. The selected count is reached when

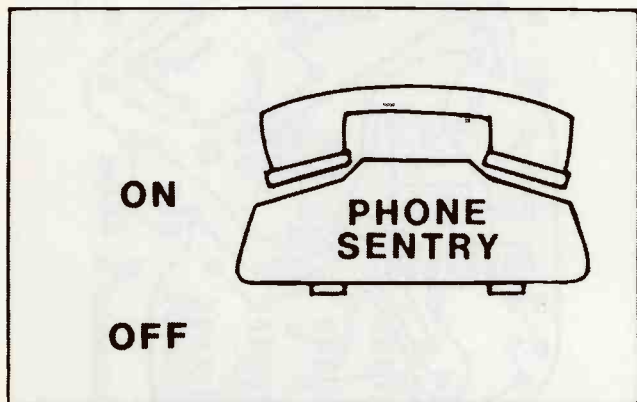
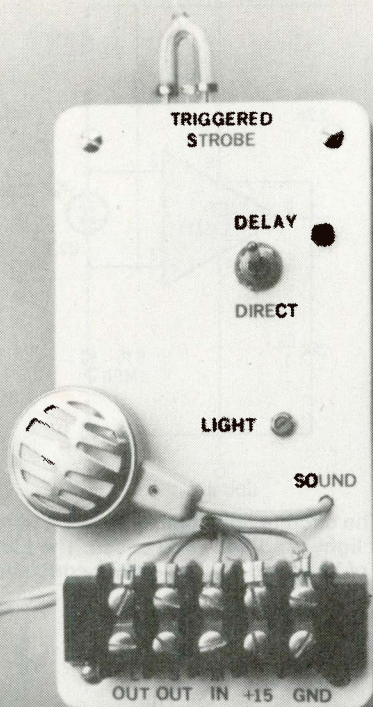

Fig. 4—This logo/label for the authors prototype type of the Phone Sentry may be cut or copied from the page and used to adorn the project's enclosure, giving the Phone Sentry a more professional, rather than a homebrew, look.

SUPER STROBE

Up in the sky; is it sound triggered!? Is it light triggered?! Is it pulse triggered?! Yes! It's Super Strobe!!

By D.E. Patrick



THE SUPER STROBE IS A VERY VERSATILE PROJECT. Unlike many projects based on strobes, such as in a light-operated slave mode or sound-operated mode, you're limited only by your imagination with such a multifaceted project.

For example, using a photodiode or transistor as a light sensor, the unit may be used as a slave strobe or flash. Thus, it can be triggered by a camera's flash unit and used as an auxiliary unit. Using a moving object such as a fan's blades as a shutter, it can be employed to make the blades seem to stand still. The presence, absence, or reflection of light may be used to trigger the unit.

Also, sound can be used as a trigger source. For example, the action of smashing a light bulb or popping a balloon can all be frozen in time on film.

External pulses might be used to accomplish the same end from another circuit, or even music for psychedelic effects.

Even a pulse stretching circuit is supplied to help expose different types of film!

Trigger and Supply Boards

The unit is composed of two simple circuit boards: the flashtube power and trigger board, and the flashtube control board. Both units can be operated directly from line voltage. However, an isolation transformer is strongly recommended to prevent any shock hazards.

A 117-to-150-volt transformer is shown as T1 and a 10-to-20-volt transformer is shown for T2 on the control board to be discussed later, but they can be the windings of a single transformer.

In any case, the flashtube trigger board (see Fig. 1) contains a voltage-doubler circuit composed of C1, D1, C2, and D2. The voltage doubler provides from 250 to 400 VDC to operate the flashtube. But the voltage doubler may be eliminated with a transformer having a 300-volt secondary wind-

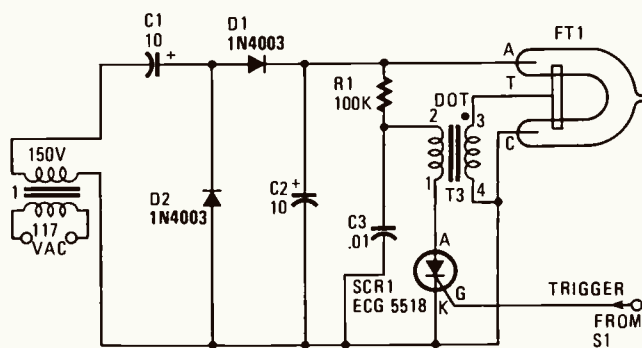
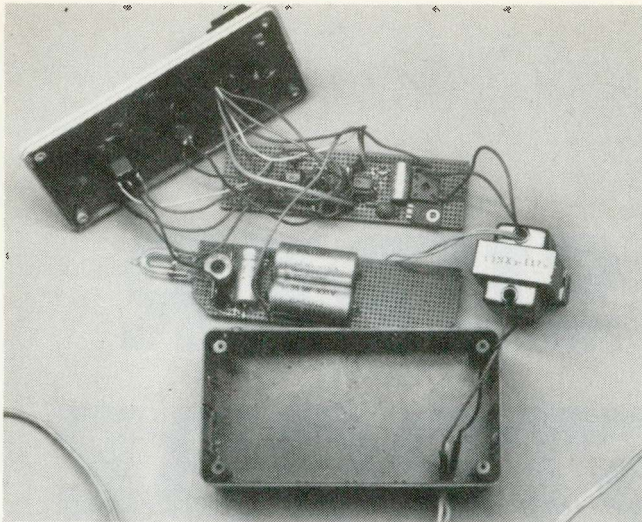

Fig. 1—The flashtube supply board is very similar to one featured in the February issue. In fact, you can use that project along with the trigger board in this article to make your Super Strobe after disconnecting the neon trigger.

ing. Also, we need around a 3- to 5-kV trigger pulse to fire the flashtube. That voltage is generated by R1, C3, T3, and SCR1.

When power is first applied, SCR1 is off, allowing C3 to charge up to the voltage supplied by the voltage doubler thru R2. The voltage across R2 is coupled thru T3 to SCR1's anode. When a positive pulse is applied to SCR1's gate, it will turn on, allowing C3 to discharge thru the primary of T3. Thus, the high voltage pulse or spike needed is generated across T3's secondary and applied to the trigger electrode of the flashtube.

Since the voltage doubler applies approximately 300 volts across the flashtube, when the trigger voltage reaches 3 to 5 kV, the gas inside the tube ionizes, producing its characteristic flash of white light. C3 discharges thru T3, SCR1 turns off again, and the cycle of events will repeat itself when a positive trigger pulse is applied to SCR1's gate. The max-



Notice that none of the parts are grounded to the case, and the case is plastic. Instead they share a common. That is to prevent accidental shock from the high-voltage circuit.

imum flash rate is determined mainly by the time constant of the R1-C3 combination.

Conditioning and Control Board

Power for the flashtube control board (see Fig. 2) is supplied by T2 (or a second winding of T1, if you prefer). In the prototype, a two-winding transformer yanked out of an old surplus calculator was used, with the low-voltage winding

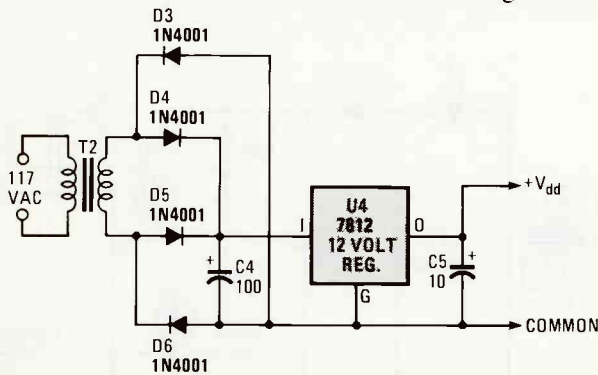

Fig. 2—The power supply for the project taken from an old fluorescent-display calculator. This provided windings for both the trigger and flashtube supply boards.

supplying 20 volts. That was rectified by a four-diode bridge rectifier (D3 thru D6), filtered by C4, and regulated by U4 (a 5-volt 7805). A 7815 or 7812 providing +15V or +12V, respectively, might also be substituted, by making changes in the conditioning circuits.

In any case, in Fig. 3 you can see that U1 (an LM311 comparator), R12, R13, R14, and R15 condition the input from D7; a photodiode for light-triggering capability. U1 compares the voltages between pins 2 and 3. When light strikes D7, its reverse-bias resistance drops and the voltage on pin 2 drops as well, which triggers the comparator. Variable resistor R12 allows you to adjust for different light conditions and diode types.

However, a phototransistor may also be used as an optional optical-pulse input if desired (see the optional configurations in Fig 4). That will make the trigger thresholds higher, and dark to light (Fig. 4A) or light to dark (Fig. 4B) triggering possible.

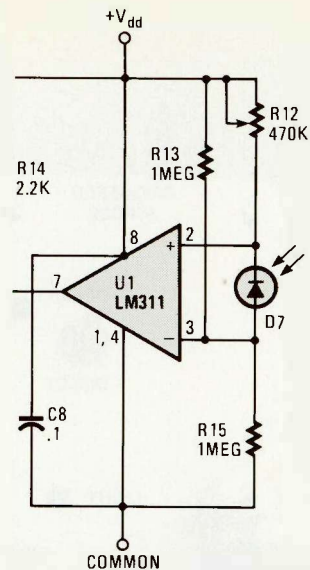

Fig. 3—The circuit's adjustability allows it to respond to whatever light conditions you choose. The LM311 is used because of its speed and low-power consumption.

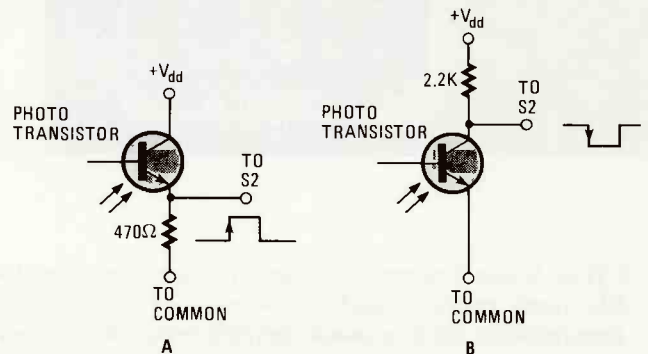

Fig. 4—Use of phototransistors in place of the photo-diode permits the detection of either dark to light (4A) or light to dark (4B) transitions.

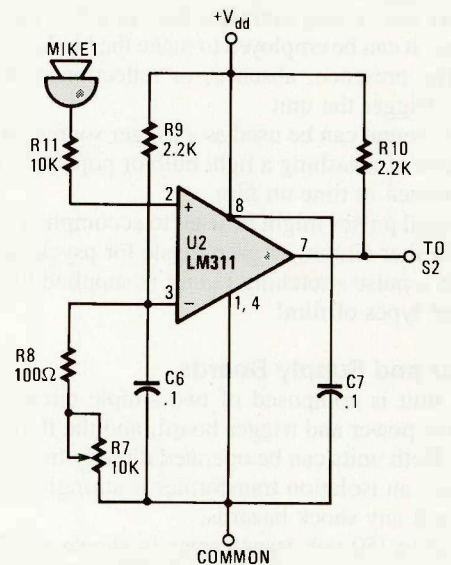

Fig. 5—The sound-activated portion of this circuit makes it excellent for capturing wild animals on film at night. If you've got an electric shutter, you can use the strobe as both the trigger circuit, and the flash unit.

In Fig. 5, U2 (another LM311 comparator), R7, R8, R9, R10, R11, and C6 condition the input from MIKE1—a crystal

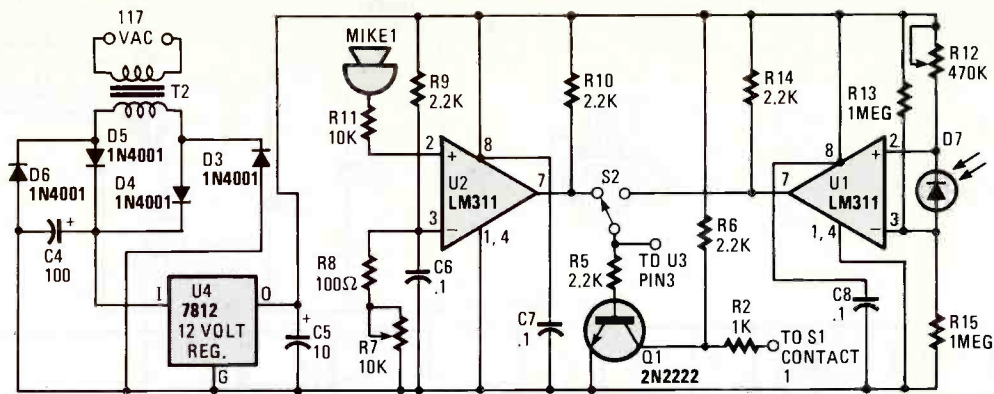

Fig. 6—If you wish to trigger the strobe on light-to-dark transitions with the diode configuration, then bypass transistor Q1 by connecting U1's output directly to the SCR gate.

PARTS LIST FOR THE SUPER STROBE

SEMICONDUCTORS

- D1, D2—1N4003 rectifying diode or equivalent
- D3—D6—1N4001 rectifying diodes or a 1-amp bridge.
- D7—Photodiode (see text)
- LED1—Light-emitting diode
- Q1—2N2222 NPN switching transistor (2N2222A, 2N3904, or equivalent)
- SCR1—ECG5518 Silicon-controlled rectifier (Radio Shack 276-1000 or equivalent)
- U1, U2—LM311 comparator or equivalent
- U3—7555 CMOS timer
- U4—7805 5-volt, 1-A regulator (see text)

CAPACITORS

- C1, C2—10- μ F, 300-WVDC, electrolytic
- C3—.01- μ F, 400-WVDC, disc
- C4—100- μ F, 100-WVDC, electrolytic
- C5—10 to 47- μ F, 25-WVDC, tantalum
- C6, C7, C8, C9, C10—.1- μ F, disc

RESISTORS

- (All fixed resistors are 1/4-watt, 10% units unless otherwise noted.)
- R1—100,000-ohm, 1-watt
 - R2—1000-ohm
 - R3, R4—1000-ohm for 12- to 15-volt supplies, and 470-ohm for a 5-volt supply
 - R5, R6, R9, R10, R14—2200-ohm
 - R7, R11—10,000-ohm (R7 can be linear-taper potentiometer)
 - R8—100-ohm
 - R12—470,000-ohm (can be a linear-taper potentiometer)
 - R13, R15, R16—1-Megohm (R16 can be a linear-taper potentiometer)

ADDITIONAL PARTS AND MATERIALS

- T1, T2—Power transformer, 117-VAC, 1-A primary; 150-volt and 20-volt secondary windings, which can be the windings of a single transformer (see text for more).
- MIKE1—Crystal microphone
- Case, line cord with molded plug, hardware, hookup wire, terminal block, perfboard, solder, etc.

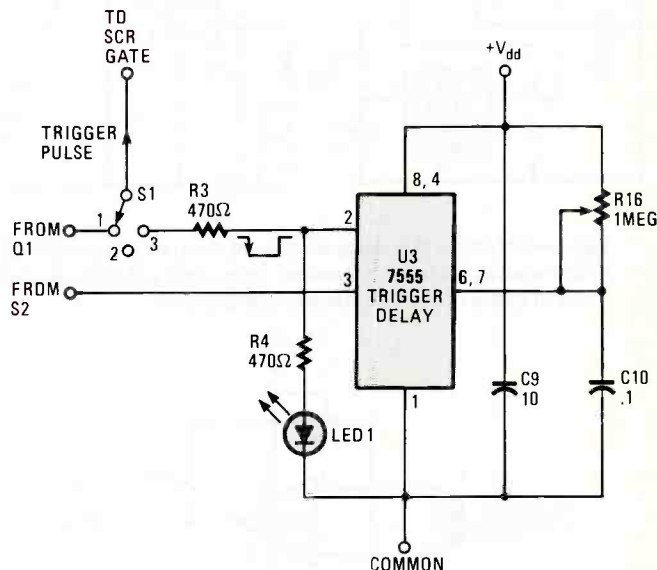

Fig. 7—The 7555 timer is operated in monostable mode, and enabled by a logic low. This allows the flash to remain on for a longer period of time in order to expose a slower film, or for special effects. Note that leaving the strobe on for too long will burn out the project.

logic trigger pulses. Thus, Q1 is used (see Fig. 6) to invert their pulses and output to the SCR.

S1 (see Fig. 7) feeds SCR1's gate with direct output from the collector of Q1, in position 1. In position 2 SCR1's gate can be triggered by anything you care to connect to contact 2 on S1. In position 3, the output of U3 (pin 3) is fed to SCR1's gate.

U3 accepts input from one of the trigger circuits (a logic low) and remains on for a time set by C10 and R16. This allows the circuit to stay on longer to expose less sensitive film, or for streaking effects.

The output of U3 simultaneously drives both LED1 and the gate of SCR1. Thus, LED1 can be used to indicate that the control section is working properly. Also, R16 is variable to permit adjustment of the time stretching, and C10's value may be increased for longer times, or lowered for shorter times.

An optional switch S2 allows the user to select between sound or light pulse triggering (see Fig. 8). But, a screw type terminal block may also be substituted, where frequent set up changes are not required. The prototype shown in the photos uses the latter configuration with a 5-position terminal block on the outside of the enclosure. There, the common, +V_{dd},

microphone used for sound triggering capability. As micro voltage is produced by MIKE1 due to sound waves, it triggers U2 into action. U2 outputs a low which acts as an input pulse.

The outputs of both U1 and U2 (logic lows) must be inverted to be of any use to the SCR, which requires high-

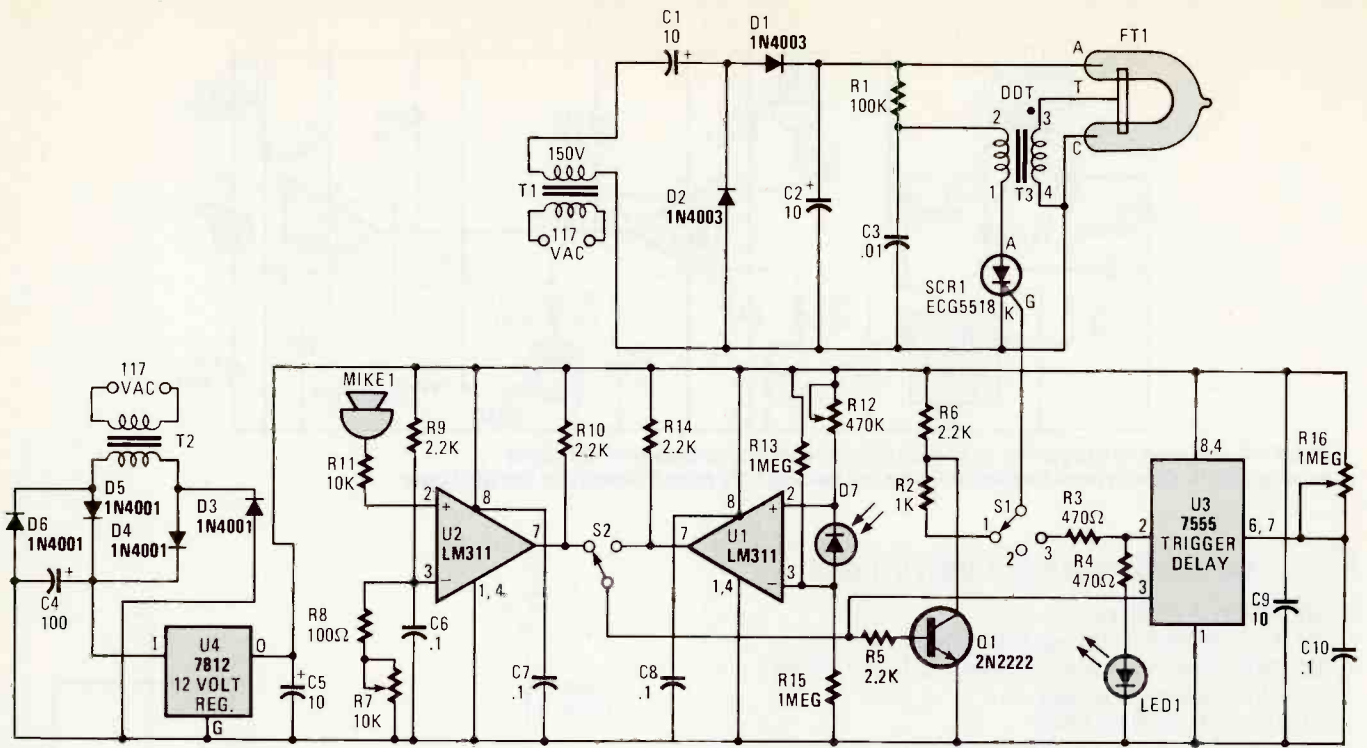

Fig. 8—Although this diagram shows the use of a switch (S1) for mode selection, in our model, we used a terminal strip. Also a double secondary transformer was used in place of the two transformers shown.

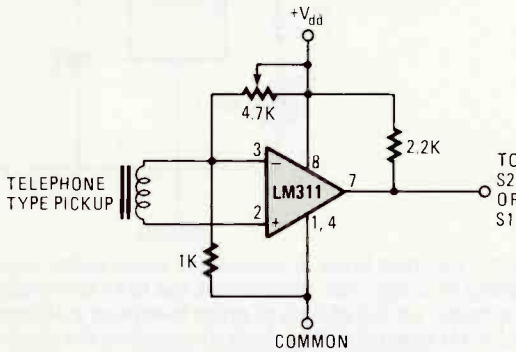

Fig. 9—The telephone pick-up sensor is useful for monitoring the action of relays. By placing the pickup next to the solenoid, when the solenoid is activated the strobe will flash. Thus, the strobe can be tripped by a solenoid or motor without messy wire connections and disconnections.

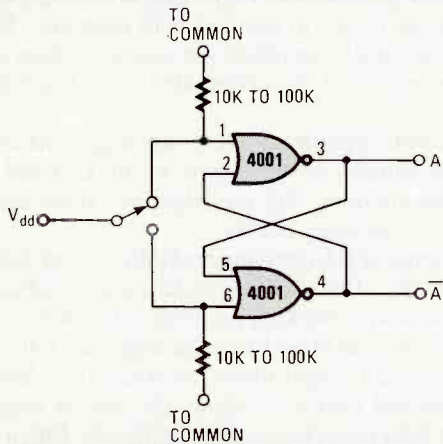
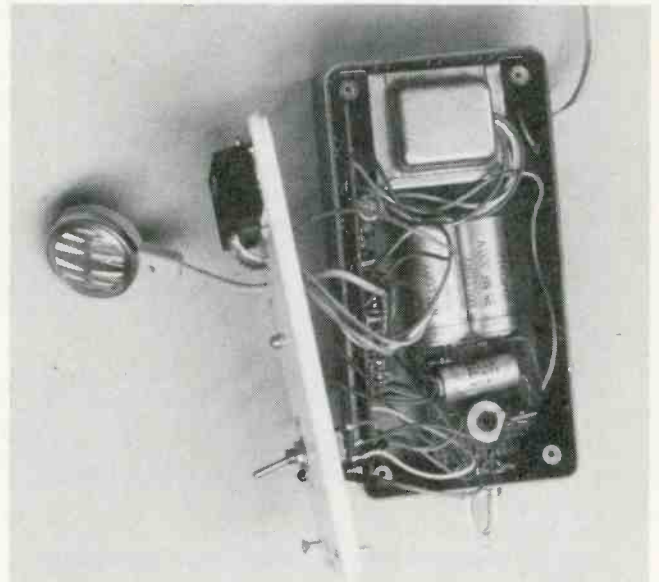

Fig. 10—A mechanical switch can be used with this debouncer to activate the strobe in either the on or off mode. This is accomplished by selecting the desired output pin (3 or 4). This is useful for burglar-alarm systems so long as the camera is well protected from theft.



All parts should fit neatly in the plastic case without any lines being shorted. All high-voltage leads should be insulated from metal parts, as a lack of insulation may lead to arcing. A good insulating material is silicon rubber.

comparator outputs, and pulse stretch input, are easy to get at and play with.

Optional Control Circuits

There are some optional control and signal-conditioning configurations, all of which can readily be built from parts in most junk boxes. Note that trigger circuits connected directly to contact 2 of S1 must be positive going, while those connected to S2 must be negative going.

Please also note that when using the pulse stretcher or external trigger, that you should *never* allow the trigger pulse

(Continued on page 160)

HOURTUNE

Take one LCD watch, add it to this circuit, and you'll be serenaded by a different tune at the stroke of each hour

By Robert E. Damm

□ THE DEVELOPMENT OF THE INTEGRATED CIRCUIT HAS BROUGHT about many changes in our purchasing habits. Things that once were bought, maintained, and repaired when necessary are now, for the most part, disposable items. Take the black and white TV for example. With many of them selling for \$60 or less, it is more cost effective for the consumer to toss it rather than repair it when it becomes inoperable. The digital watch is another item that has fallen prey to the disposable syndrome—with very inexpensive models selling for under \$5, or assorted firms giving them away as an incentive to get you acquainted with their product.

Well, if I have an old LCD watch whose only purpose is to serve as a dust collector, why not pull it out and use it in this novel watch-controlled melody-generator project. We call it *HOURTUNE*. The project consists of four simple circuits: a trigger (which includes the LCD watch), timer, melody synthesizer, and amplifier circuits. The key circuit is the trigger circuit (which is controlled by the LCD watch). That circuit turns on the other three circuits once each hour, just long enough for one of the twelve melodies contained in the melody synthesizer to be played.

At the end of the tune, the circuit turns itself off for an hour to conserve its power supplies. Then, when the next hour arrives, it turns itself on again and plays a different melody etc. Let's see how HourTune does its thing.

A Look at the Circuit

A schematic diagram of the *HOURTUNE* circuit is shown in Fig. 1. The trigger circuit is made up of seven components; an LCD watch with a chime function, an optoisolator/coupler (U1), transistor (Q1, a 2N2222 general-purpose), a resistor (R10), two 5-volt reed relays (K1 and K2), and a switch (S1). The trigger circuit is powered by the plug-in wall transformer and the battery contained in the wrist watch.

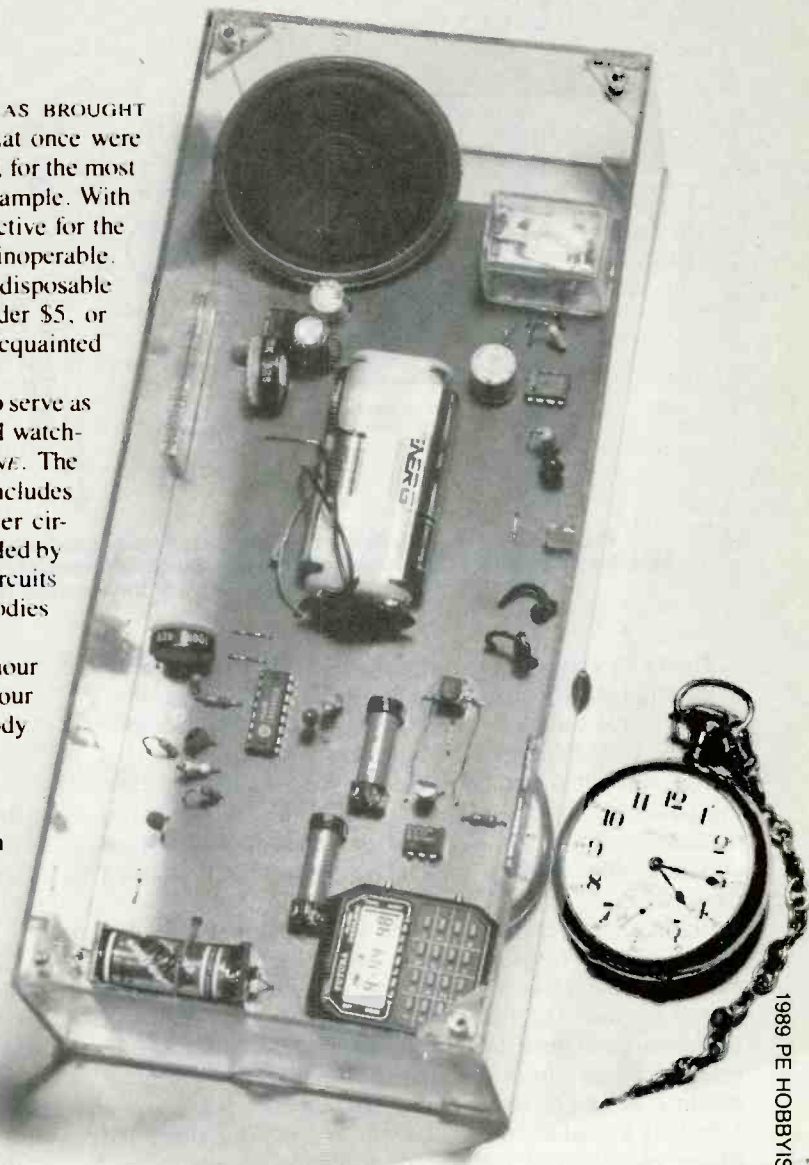

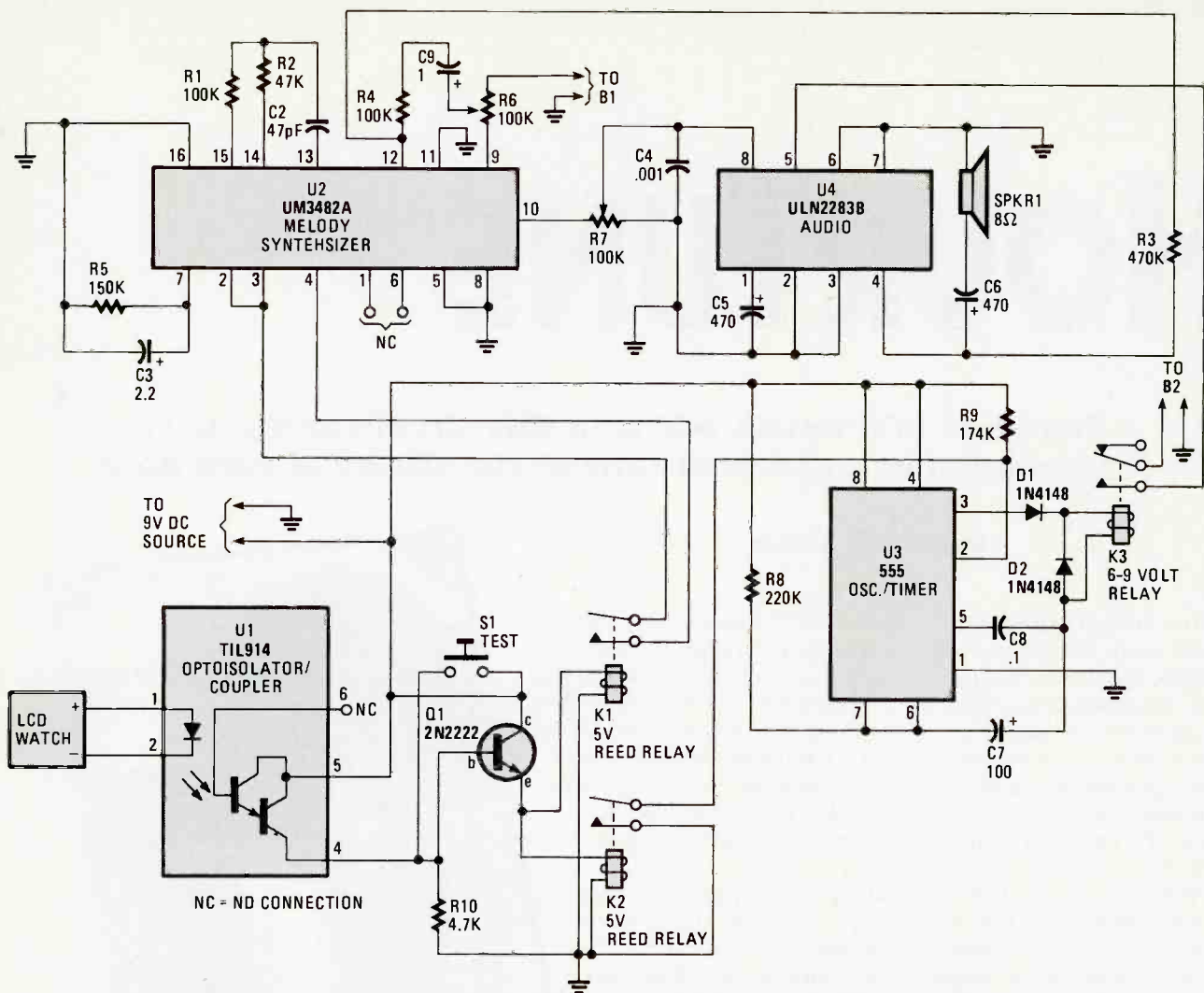

Fig. 1—HourTUNE, a wristwatch-controlled melody generator, is comprised of four subcircuits; a trigger circuit (which includes the LCD wristwatch), the melody circuit (consisting of U2 and a couple of support components), the timer (built around a 555 oscillator/timer), and the amplifier (a ULN2283B low-power audio amplifier chip).

The LCD watch's chime-triggering circuitry is connected to the input of an optoisolator/coupler (U1) so that the chime-trigger signal turns on U1's internal LED. Light radiation from the LED falling on the light-sensitive area of the U1's Darlington-output element causes it to turn on, thereby closing the contacts of reed relays K1 and K2. Relay K1 has its two contacts connected to U2 pins 2/3 and pin 4, which when closed, enables the chip and causes it to advance to the next tune.

Relay K2 has one contact tied to ground and the other connected to the trigger input (pin 2 of U3) of timer circuit, so that when the LCD watch outputs a chime-trigger signal timing begins. The timer—built around a 555 oscillator/timer—is configured to remain on for 29 seconds after it receives a pulse from the relay. The purpose of the timer circuit is to turn on the amplifier through relay K3.

Initially I used a nine-volt battery to power the timer and trigger circuits, but that proved unsuitable because battery life was short; lasting only about a week and a half—and that just ain't good enough. So, I decided in favor of a wall-mounted DC power pack, like the type used for video games, etc. The transformer used in the final version was salvaged from an old in-line amplifier (ARCHER 15-1117 Model PI-

001), with a rating of 9-volts DC at 10 mA. I also tried a charging transformer (taken from an old grass-shear) with a rating of 7.5 volts DC at 125 mA, and it worked fine.

The timer controls the amplifier circuit (which is built around U4, a ULN2283B low-power audio amplifier) through relay K3. When K3's contacts close, power is supplied to the +V input of U4, turning it on. The amplifier circuit (which has a low quiescent current drain) is powered by two "AA" penlight batteries.

Now for the final circuit; the Melody Generator UM-3482A (U2), which contains 12 tunes, is turned on by reed relay K1 and it is wired according to the general application which is packaged with the chip, except that pins 2, 3, and 4 are hard wired into a configuration that assures that each hour will change the tune and it will auto stop after one tune. The chip is powered by an N-type battery, B1.

The momentary pushbutton switch, S1, is used to re-cycle the tunes that you will hear and to test the circuit's operation. Since the LCD wristwatch gives a double pulse, each time the chime goes off, it causes the generator to play every second tune—in other words, you hear six of them over and over. All you need do is insert a tune when you wish by pressing S1, allowing you to hear the other six.

Fig. 2—If you decide to go the printed-circuit route, this full-scale template made for HOURTUNE can be lifted or copied from the page and used to etch your own printed-circuit board. The simplest method of producing the circuit board is to use Lift-It film to pluck the circuit pattern from the page. Then using the Positive Photo-resist method of printed-circuit preparation, you can etch your own circuit board.

PARTS LIST FOR HOURTUNE

SEMICONDUCTORS

- D1-D2—1N4148 small-signal silicon diode
- Q1—2N2222 transistor (Radio Shack # 276-2009)
- U1—TI914 optoisolator/coupler (Radio Shack # 276-139)
- U2—UM3482A melody generator (Radio Shack # 276-1797)
- U3—NE555 oscillator/timer (Radio Shack # 276-1728)
- U4—ULN2283B low-power audio amplifier (see text)

RESISTORS

(All resistors 1/4-watt, 5% fixed units unless otherwise noted.)

- R1-R4—100,000-ohm
- R2—47,000-ohm
- R3—470,000-ohm
- R5—150,000 ohm
- R6-R7—100,000-ohm, trimmer potentiometer
- R8—220,000-ohm
- R9—174,000-ohm
- R10—4700-ohm

CAPACITORS

- C1-C3—2.2- μ F, 16-WVDC, Tantalum
- C2—47-pF, ceramic disc
- C4—0.001- μ F ceramic disc
- C5-C6—470- μ F, 16-WVDC, electrolytic
- C7—100- μ F, 16-WVDC, electrolytic
- C8—0.01- μ F, mylar
- C9—1- μ F, 16-WVDC, Tantalum

ADDITIONAL PARTS AND MATERIALS

- B1—N-cell battery and holder
 - B2—AA-cell battery and holder
 - K1, K2—Relay, 5-volt reed-type (Radio Shack # 275-232)
 - K3-K6—Relay, 9-volt coil (Radio Shack # 275-004)
 - LCD1—LCD wristwatch (see text)
 - S1—Normally-open, momentary contact pushbutton switch
 - SPKR1—miniature 8-ohm speaker
 - T1—9-volt DC plug-in wall transformer (see text)
- Printed-circuit board material or preboard, etching solution, plastic case, wire, solder, hardware, etc.
- Note: All parts for HOURTUNE, except for the ULN2283B audio amplifier, are available from local or mail-order parts stores. The amplifier is available—by mail order, priced at \$1.40—from Circuit Specialist Co., PO Box 3047, Scottsdale, AZ 85257.

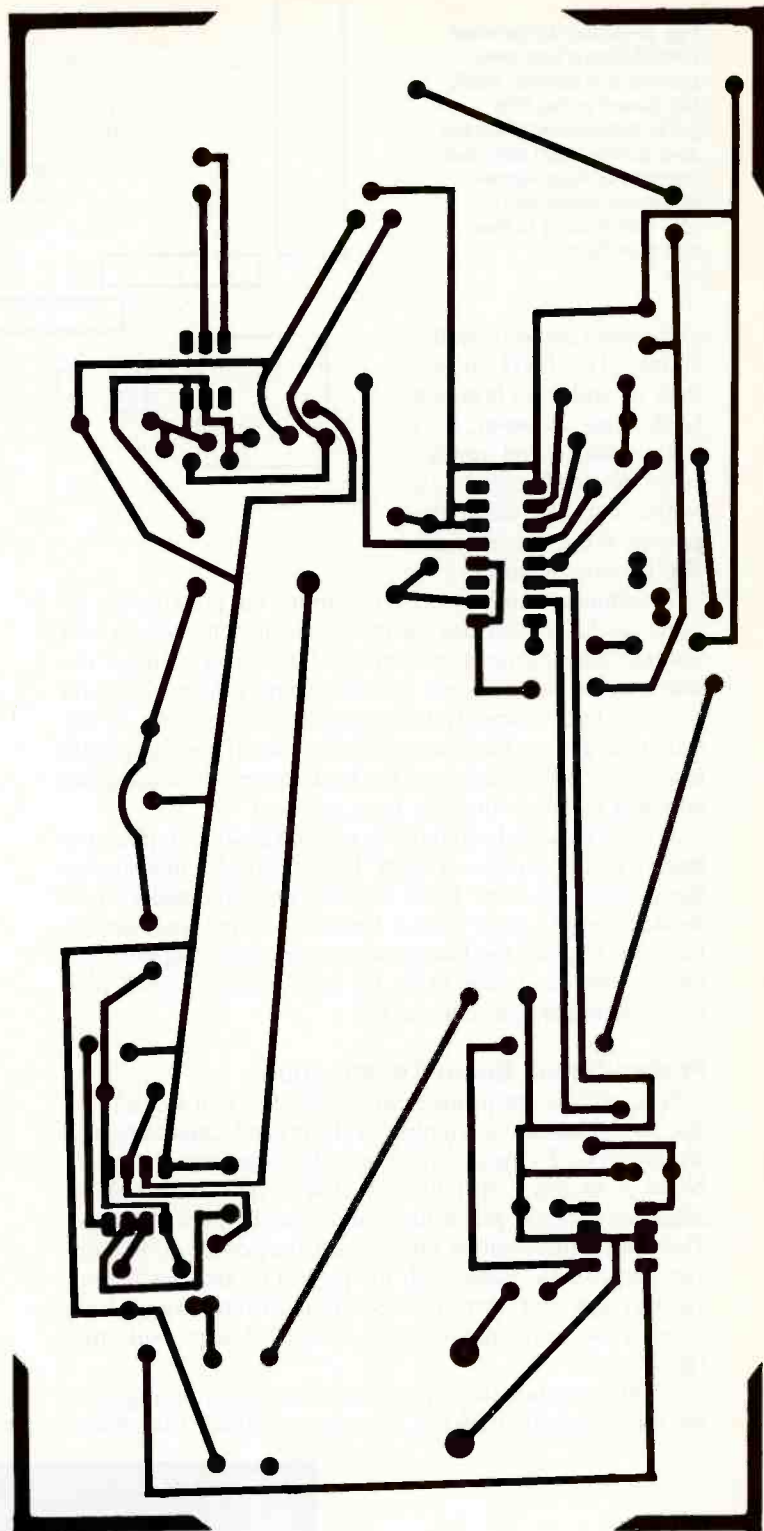

Watch Preparation

The first thing that must be considered before HOURTUNE can be started is the LCD wristwatch. The watch must have an hourly chime function—a feature that's incorporated into many inexpensive watches on the market today. So it should be no problem to find a suitable one. In fact, you probably have one lying around somewhere. The one I used for the project was sent to me by a vitamin company as an incentive when I purchased their product.

I also purchased ten watches from a west coast electronics company for \$0.39 each, and every one of them is suitable for the circuit even though they are factory rejects.

In preparing the watch, first remove the back and take out the piezo sounder disk. Carefully solder a length of wirewrap wire to each terminal that had previously made contact with the disk. Drill two small holes in the watch back, thread the wires through the holes, and close the case. Connect an LED

Fig. 3—Once the printed-circuit board has been etched and drilled, stuff the board using this parts-placement diagram as a guide. Start with the passive components—resistors, capacitors, etc—advancing to the semiconductors.

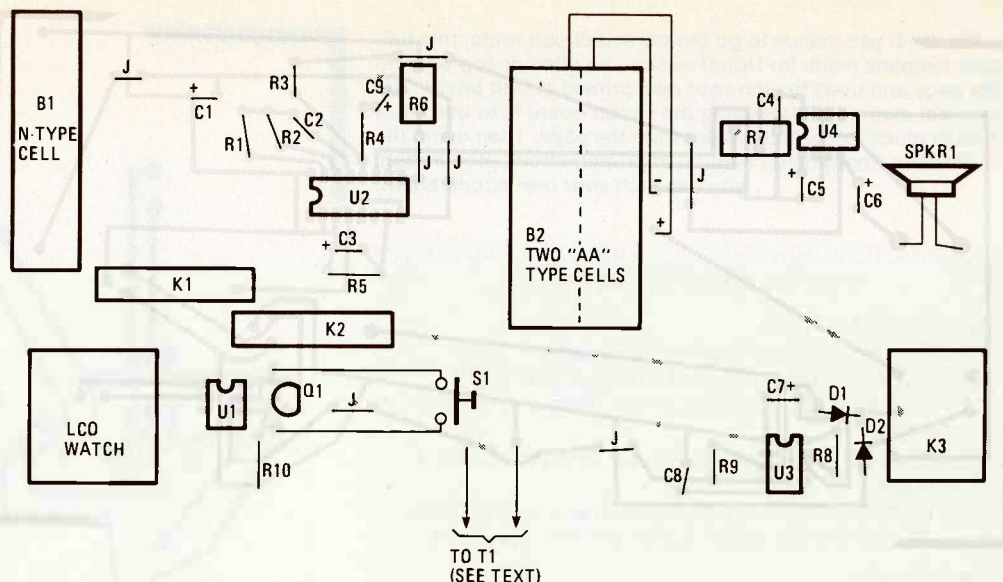

to the wires and activate the chime. The LED should flash regardless of how you hook it up. However, it is recommended that you reverse the leads and try it again, because when the polarity is correct, the flash will be more intense.

A voltmeter can be used to determine the polarity, but by using an LED, you can be more sure that the watch will operate the optoisolator/coupler. When you connect the watch to the board be sure that you connect the positive and negative leads correctly to the optoisolator/coupler. If the watch has a metal back be sure to use a small piece of plastic tape on the inside surface of the back to prevent shorting out now that the piezo disk has been removed.

If the watch has been lying around for a while, replace the battery while you have it apart. Remember also that strange things occur in some LCD watches when the battery gets weak, it might keep perfect time, but other functions go haywire. Replace the battery and everything straightens out again. Lay the watch aside for now and go ahead with confidence that you're home free.

Printed-Circuit Board Construction

Next prepare the printed-circuit board so that HOURSUNE can be assembled. A template of the printed-circuit board is shown in Fig. 2. The simplest method of producing the circuit board is to use Lift-It film (a clear acrylic film with an adhesive back) to pluck the circuit pattern from the page. Then using the Positive Photo-resist method of printed-circuit preparation, along with the pattern on the Lift-It film, you can etch your own circuit board. (Lift-It film is available at many electronic hobby stores, as well though mail-order suppliers.)

Another method (which you may find to your liking) is to use direct-etch dry transfers, which are available from Radio

Shack and by mail order, to lay the circuit out on a copper-clad slug (unetched board) using Fig. 2 as a guide. Or you could layout the components on perfboard, and use point-to-point wiring to complete HOURSUNE according to the schematic diagram (Fig. 1).

If you decide to go the printed-circuit route, stuff the board using Fig. 3 (the parts-placement diagram) as a guide. Start with the passive components; resistors, capacitors, etc. Then move on to the semiconductors. Don't forget to add the jumper connections (labeled J). Once that's done, begin mounting the battery holders (an N-type for B1 and a dual AA-type for B2), wristwatch, and speaker. Use a small piece of double-sided foam tape to attach the watch to the lower left-hand corner of the board and leave about three inches of wire coiled up underneath it, just in case you have to lift it a bit to change the battery or reset it.

Glue SPKR1 to the board in the upper right corner. Glue an N-type battery holder to the board in the upper left corner for B1. The battery holder for B2 can lay in the middle of the board, secured in place by drilling two holes through the board and using a length of wire to tie it down. Finally, cut a couple inches from a plastic drinking cup and place it over the speaker cone and it will greatly increase the volume.

With every thing now in place, power up HOURSUNE and take is for a test run. Press S1; you should hear a click from the relays, followed by a tune from SPKR1. If all seems OK, press S1 again to check that the circuit toggles to the next tune. If that checks out, box the circuit in a housing of your own choosing. Now you can play HOURSUNE. ■

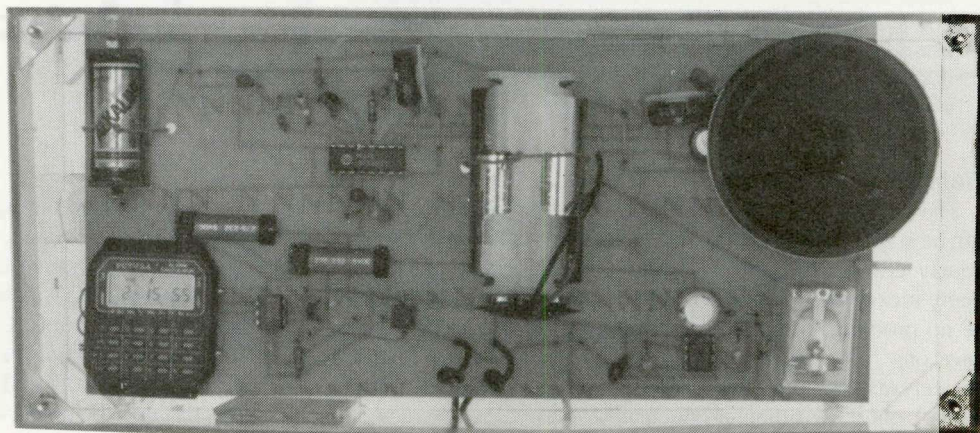

HourTune can be used to provide a melodic doorbell by connecting the doorbell switch in parallel with S2. For greater volume, a more powerful amplifier can be used to drive the speaker.



BACK IN THE EARLY DAYS OF RADIO, THE VACUUM TUBE was king of the regenerative circuits. Any replica of a golden oldie should have visible one or more vacuum tubes pouring out heat from a red glowing filament. Although the project described in this article, *Grandpa's Antique Radio*, may appear as a two-tuber, it actually performs by using solid-state devices. The vacuum tubes are there just for show. The regenerative (regen) circuit used in the radio is very old, but the radio operates with modern-day FET transistors and a single audio integrated-circuit chip. A combination of the old and the new bring back the antique radio of yesterday.

The Circuitry

The FET transistors, Q1 and Q2, and the LM386 low-voltage, audio amplifier (U1) provide comfortable earphone reception (refer to Fig. 1). Transistor Q1 comprises a broadband RF amplifier and isolation transistor. Besides amplifying the weak broadcast signals picked up by the antenna, the RF amplifier isolates the regeneration circuit—preventing RF noise from radiating directly into the antenna. The RF signal is transformer coupled via L1/L2 to the regeneration circuit. Coils L1 and L2 interact mutually as a transformer, and incorporate a ferrite core to raise the circuit's Q.

GRANDPA'S ANTIQUE RADIO

By Homer L. Davidson

Make and enjoy a radio that reflects the early 1920's

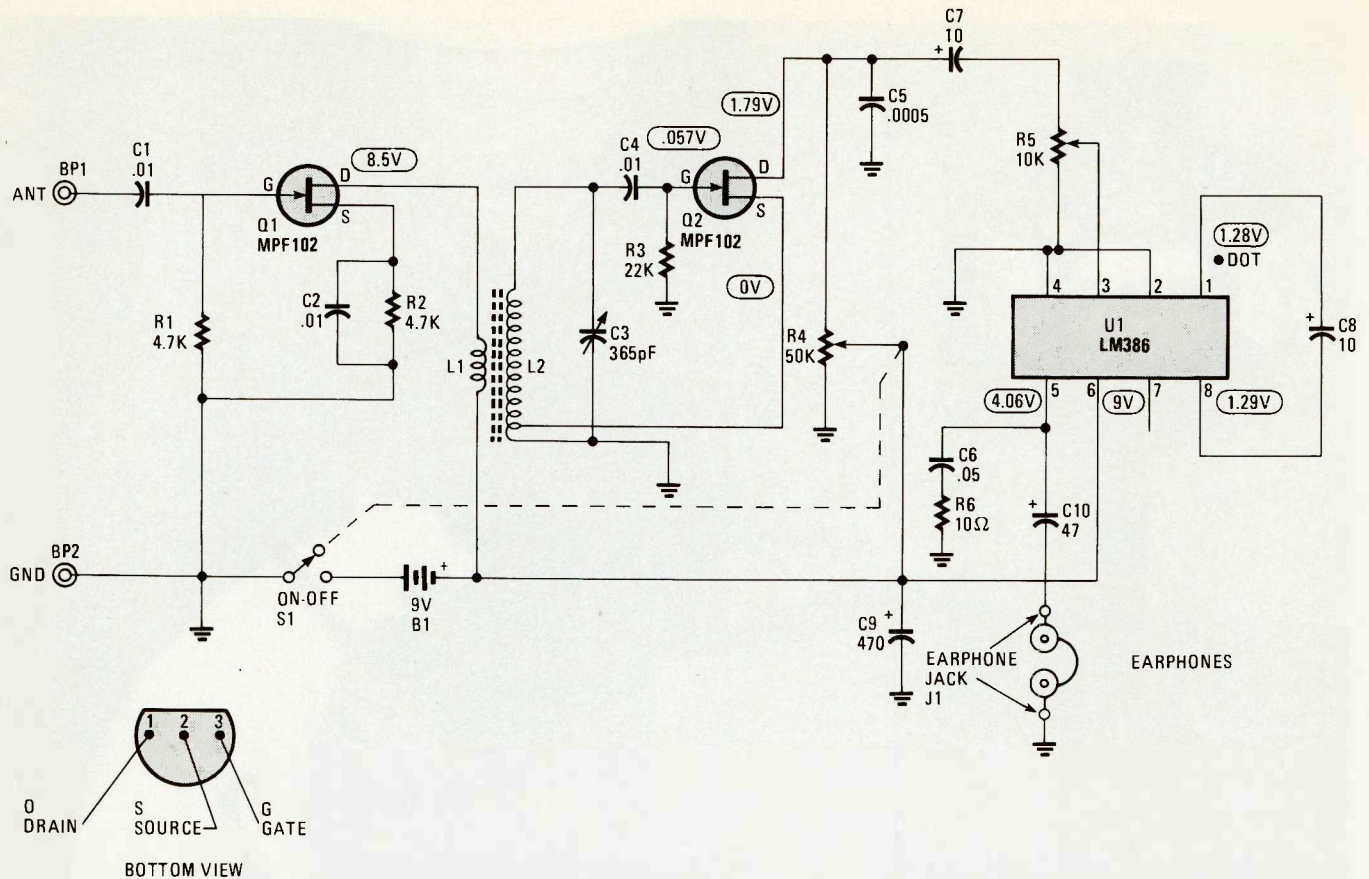

Fig. 1—Here is the schematic diagram of Grandpa's Antique Radio. It contains a regeneration circuit and modern solid-state devices. The RF and regen FET transistors (Q1 and Q2) amplify and detect the RF signal for the audio chip (IC1).

The regeneration circuit is centered about FET transistor Q2. Radio-frequency signals amplified by Q1 are coupled to coil L2. The tuned circuit is composed of L2 and tuning capacitor C3, which tunes the tank circuit and selects the desired station frequency. The gate bias for the detector stage of Q2 is developed by a grid-leak combination, consisting of C4 and R3. That combination should be called a "gate-leak," but it's too late in the radio game to coin new phrases.

Regenerative feedback is provided by connecting the source (S) terminal to the 6-turn tap of L2. The regeneration is controlled by varying the voltage on the drain terminal of Q2 with regen control R4. Now, the detected audio signal from the drain terminal is capacity-coupled by way of C7 to volume control R5.

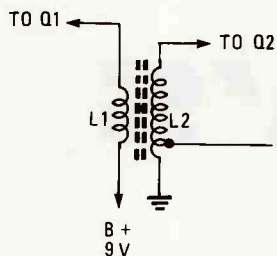

Fig. 2—Coils L1 and L2 are wound on a 1/2-inch diameter ferrite rod which may be cut to size from a longer rod. Mark a groove around the rod with a hacksaw or file and it will snap in two when tapped. Refer to text for coil winding information.

The controlled audio signal is applied to pin 3 of audio amplifier, U1. A stereo earphone jack, J1, is connected through electrolytic capacitor C10 to pin 5 of U1. Although Grandpa always used a pair of earphones (he called them cans), the LM386 power amplifier will drive a small PM

speaker. The small radio circuit, powered by a 9-volt transistor battery, has a current drain of 10.7 milliamperes. Most small battery-operated radios have an operating current drain of 8.5–20 milliamperes.

Winding the Coils

First, start winding L2 in the center of a AM-band ferrite rod with number 24 enameled wire. Refer to Fig. 2. Place a small piece of masking tape under the starting wire to hold it in place. Wind on approximately 73 turns and place a piece of masking tape over the winding while twisting the wire several times to make the tap connections. Now, wind on another six turns. A 3-inch rod should be able to hold those turns; however, you will find a slightly longer rod easier to work with. At the end of L2, place a layer of masking tape to keep the coil from unwinding. Clean off the enamel at the tap and solder a four-inch piece of hookup wire to the tap.

In the middle of L2, place a layer of masking tape. Wind 32 turns of number 28 enameled wire over the masking tape for the primary winding, L1. Secure both ends of the winding with masking tape. Both coils are close-wound (CW) and wound in the same direction. Leave four-inch connecting wires at each end of the coils.

The PC Board

A pre-drilled IC-LS1 perfboard was used as the PC board for mounting parts for Grandpa's Antique Radio. Of course, a regular perfboard will do. Here, a predrilled 2-13/16- × 3-3/4-inch perfboard was prepared by drilling two 1/2-inch holes to mount the regenerating and volume controls. Drill out the

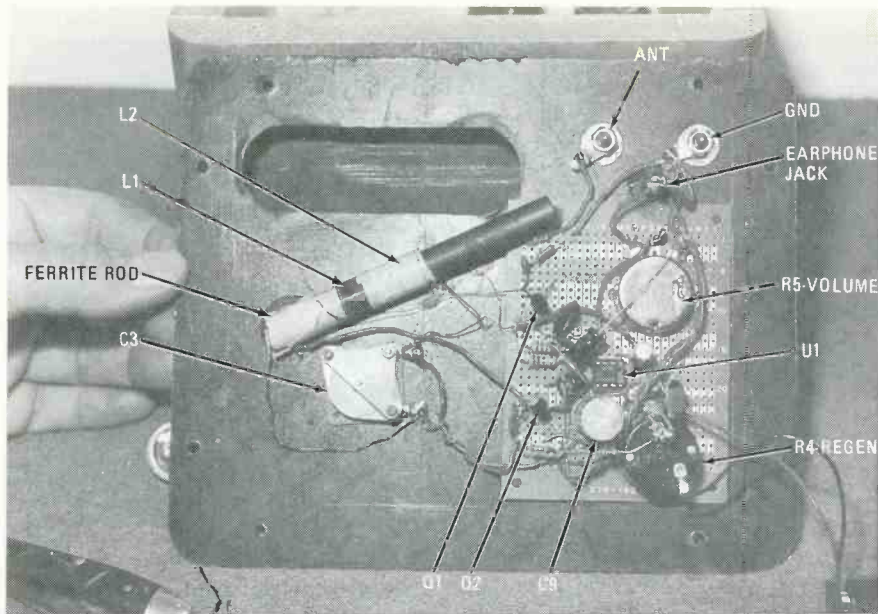

Although an IC-LS1 perboard was used to mount all small parts, a regular perboard may be used. The small parts are mounted into position as they are wired into the circuit.

Cabinet Construction

The top and bottom panels are cut from hard-tempered Masonite stock to look like a bakelite finish. All holes were drilled into the top panel before applying two coats of black automotive, spray-enamel paint. Cut out the 1-1/4- by 3-1/2-inch tube slot with a saber saw. Sand down the rounded corners of the slotted area. The two control holes must match exactly with the perboard as the control mounting nuts hold the perboard to the top panel.

perboard so both controls will fit flush with the top panel. Refer to the photos and Fig. 3. The shaft mounting nuts on the two controls will hold the PC perboard to the front panel.

The perboard is mounted 1/8 inch from the cabinet sides. Draw the cabinet sides on the bottom side of the front panel so the perboard holes will match those on the top panel. Lay the perboard on the bottom side of the top panel and center the two holes for the regen and volume controls.

Wiring Up the Radio

The mounting and wiring of the various small components is not critical provided you follow the author's layout somewhat. Refer to the author's unit shown in the photos. Place the DIP socket between the volume and regeneration control. Transistor Q1 is mounted to the left, close to the antenna and ground posts. Transistor Q2 is mounted next to the outside, near the tuning capacitor. All other small parts may be mounted as they are wired into the circuit.

Cut the cabinet sides from a piece of scrap, one-inch, white-pine lumber. If the scrap lumber is already painted, place it on the inside of the cabinet. Run a line of wood glue between the board ends and place two small finishing nails to hold the pieces together. Nail and glue the bottom panel to the cabinet.

From pin 4 of the U1 socket run a length of bare wire up the row of soldering holes for easy ground connections. Likewise, run a bare piece of hookup wire from pin 6 of the DIP socket down the soldered holes for the B+ connections. Be careful when soldering up the DIP terminals, so that excess solder does not establish a shorting solder bridge. Remove the excess solder with a piece of solder-wick mesh material.

The top panel is held to the cabinet with eight metal screws. Round off the corners of the cabinet and panels with a bench sander, if handy. Countersink the finishing nails so that the corners can be rounded off. Finish up with fine sandpaper on the side and corner areas. Spray two coats of metallic-silver automotive paint on the wooden cabinet. Two coats of black auto spray paint is applied to the front panel before it is mounted. Sand between coats with real fine sandpaper or steel wool.

Use a pocket-knife blade between the two rows of terminals to clean out solder from the adjacent terminal as the solder is heated. Keep the soldered connection close to the perboard, so the board fits tightly against the front panel.

Solder up two 3-inch pieces of hookup wire for the ground and antenna terminals. Likewise, solder another set of three-inch length pieces to tie the variable capacitor to the perboard. Now, set the perboard aside and finish up the front panel.

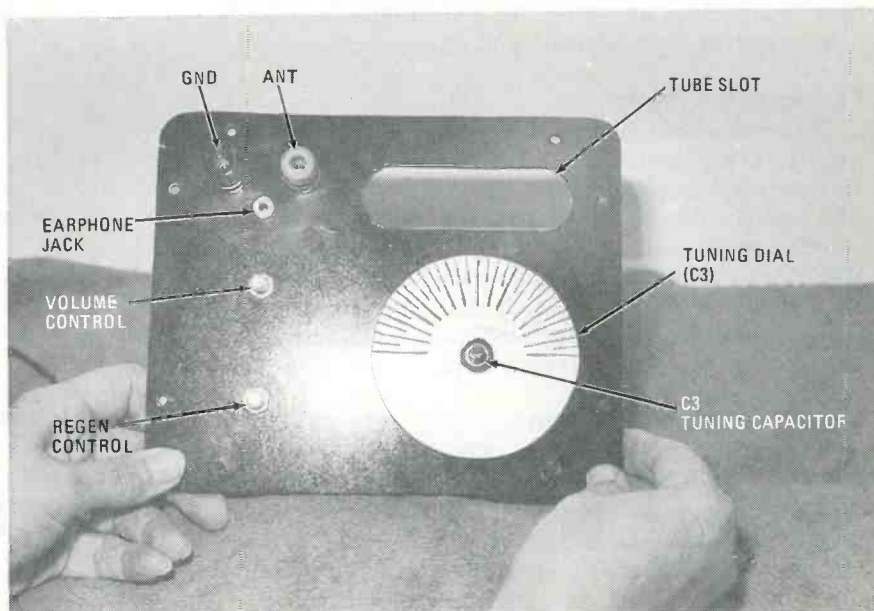

Shafts of both controls go through the perboard and top panel. All parts of the radio are mounted upon the back side of the top panel, which is fastened to the cabinet with flathead screws.

Connecting Together

Bolt the ground and antenna post in their respective holes on the front panel. Refer to the photos. Next, mount the miniature variable tuning capacitor. Fasten the perfboard to the top panel with the control nuts. The antenna ferrite coil is not glued into position until Grandpa's Antique Radio is operating.

Connect the two wires to capacitor, C3, with the ground wire going to the rotor terminal of the capacitor. Solder the

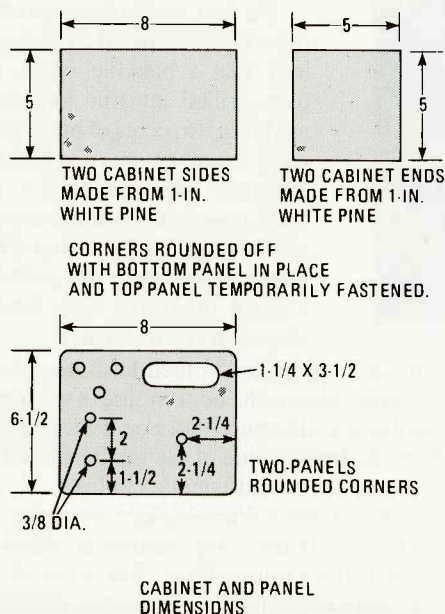

Fig. 3—Here are the cabinet's surface dimensions. Fasten top, and side panels to the cabinet and round off the corners together with a bench or portable sander. Drill out the ends of the slotted tube areas with a 1/4-inch circle cutter.

connections of L2 to C3 (as shown in Fig. 1) capacitor. Tie the ground and antenna wires to their respective posts. Connect the 9-volt transistor battery (B1) terminal to the on/off switch (S1, which is a part of the volume control, R5) terminals. Wire up the stereo headphone terminals to J1. Mount U1—be sure that pin 1 of U1 sits at the correct position in the socket. Now double check all wiring. An 8 to 39-ohm low-priced, light-weight, stereo headphone works nicely here.

Power Up the Radio

The antenna radio should be tested before the front panel is mounted to the cabinet. Plug in the earphones and battery. Turn the volume control full on. Now, rotate the regeneration (C3) control until a squeal is heard. For best results, a 50-ft. outside antenna and a good earth ground should be used. Rotate the variable tuning capacitor and notice several squealing stations on the band. Readjust the regeneration and volume control for normal earphone listening. Fasten the coil in position with rubber silicone cement.

Troubleshooting the Radio

Double check all wiring if the radio does not operate the first time. If a VOM or DMM is handy, take voltage and current measurements. Insert the DC 20-milliamper meter leads in series with one lead of the battery.

If the radio is dead and the meter indicates heavy operating current over 20 milliamperes, suspect a leaky transistor or

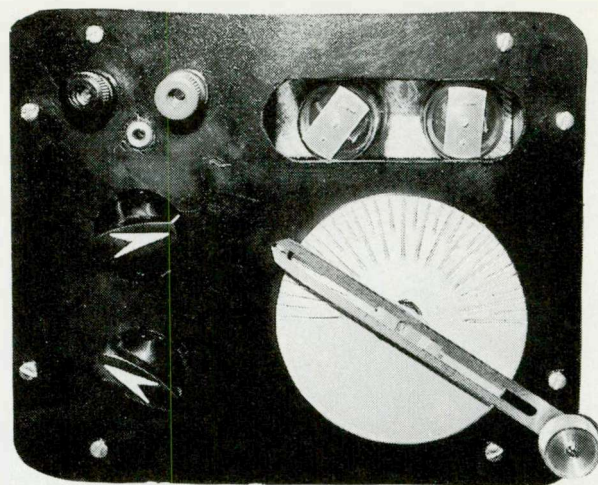

If antique knobs are not available, make some of your own. The round dial assembly was made from a piece of plastic with lines drawn through with a small soldering iron. Two coats of silver metallic spray paint makes it appear like a metal dial.

IC. This little radio pulls only 10.7 mA, with the volume clear down and 13.9 mA with a strong station turned in. No current indicates voltage is not applied to the correct IC or transistor terminals. Take critical voltage measurements on the IC and transistors. Compare your operating-voltage measurements with those found in the schematic diagram (Fig. 1).

Make sure that U1 is inserted into the socket with the polarization dot or slot near pin 1. Re-check the bottom view of each transistor connected with the circuit. If Q2 does not oscillate or make a squealing noise as the regeneration control is advanced, re-tap the coil at the 7th or 8th turn from the ground end of L2. For added volume, try reversing the terminals of L1.

Old Tube Mounting

To make the antique radio have a vacuum-tube operating

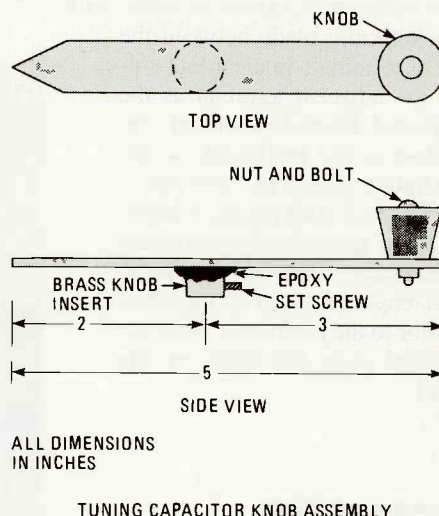
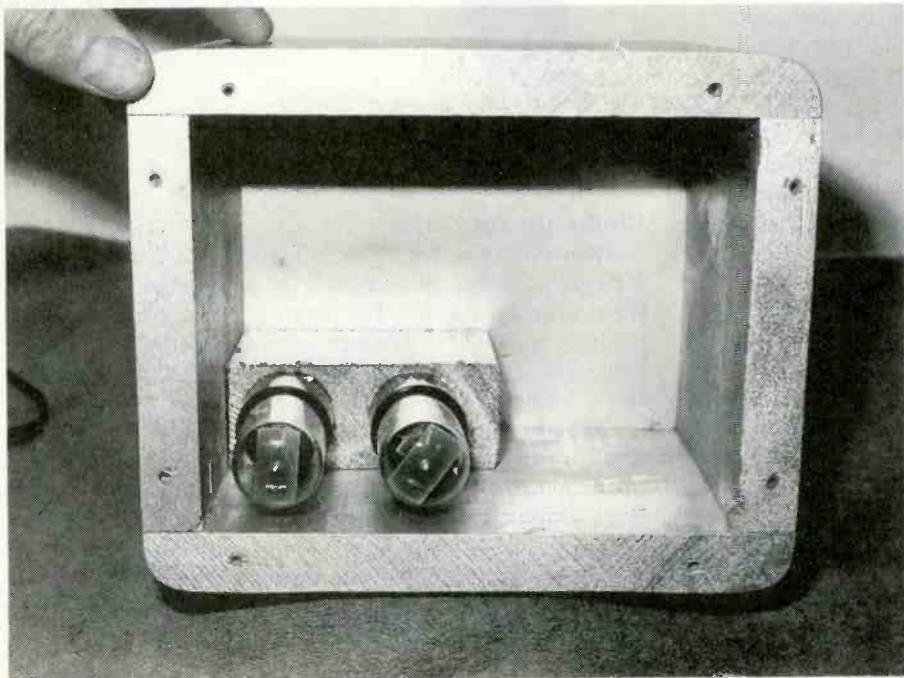

Fig. 4—The metal pointer was constructed from a discarded brass-plated lid support; use a piece of solid brass or copper. Drill a 1/8-inch hole to secure the small radio knob and epoxy the 1/4-inch shaft insert to the under side of the dial pointer to attach to the shaft to the tuning capacitor.

PARTS LIST FOR GRANDPA'S ANTIQUE RADIO

- B1—9-volt, transistor-radio battery
BP1, BP2—Multi-way binding post (one red, one black)
C1, C2, C4—.01- μ F, 100-WVDC, ceramic disc capacitor
C3—365-pF, miniature, variable capacitor (Coleco A1-233, Circuit Specialists A1-233, or equivalent.)
C5—.005- μ F, 100-WVDC, ceramic disc capacitor
C6—.05- μ F, 100-WVDC, ceramic disc capacitor
C7, C8—10- μ F, 15-WVDC, electrolytic capacitor
C9—470- μ F, 15-WVDC, electrolytic capacitor
C10—47- μ F, 15-WVDC, electrolytic capacitor
U1—LM386 low-voltage 7-watt, audio power-amplifier integrated circuit
J1—Earphone jack, miniature-type
Q1, Q2—MPF102 FET transistor (Radio Shack, Circuit Specialist, or equivalent.)
R1—4700-ohm, $\frac{1}{2}$ -watt resistor
R2—470-ohm, $\frac{1}{2}$ -watt resistor
R3—22,000-ohm, $\frac{1}{2}$ -watt resistor
R4—50,000-ohm, potentiometer with SPST switch (S1)
R5—10,000-ohm, audio-taper, potentiometer
R6—10-ohm, $\frac{1}{2}$ -watt resistor
R7—1000-ohm, $\frac{1}{2}$ -watt resistor
Perboard (Radio Shack 276-162), 8-pin IC socket, 8- to 30-ohm stereo headphones, 9-volt battery connector, hookup wire, cabinet material, scrap brass, white pine wood, flathead screws, paint, dummy tubes, knobs, etc.

appearance, two dummy tubes are mounted under the slotted area in the front panel. Cut a piece of white pine 2 \times 4 inches. Drill two large side-by-side tube mounting holes. The holes should be just large enough so that the prongs of the tubes will fit down inside. Cement the bottom side of the tubes into the mounting holes. Place the tubes directly under the slotted area. Cement the tube board to the bottom panel. If you wish, add a filament transformer to the project and power up the filaments of the vacuum tubes only! The glow



The radio pulls 10 mA with the volume turned down. If the current measurement is over 17–20 mA, suspect incorrect wiring or a leaky transistor or IC. Critical voltage and current measurements should help locate the defective component.

from the tubes with the attending heat will add the atmosphere Grandpa enjoyed years ago.

The Final Touches

Nothing can give Grandpa's Antique Radio that old-fashioned appearance more than radio knobs. If you can not come up with some antiquated knobs, simply make them. The dial of the main tuning capacitor was constructed of a piece of white plastic. (An aged yellow color would be better.) Lines were drawn within the plastic surface with a flat blade of a soldering iron. Grind the soldering-iron point flat on both sides. Use a metal ruler or straight edge to gouge various lines in the dial assembly. Sand or file down the raised edges. Place black paint in the grooved lines and wipe off the excess paint. Glue the dial in place. (See photos.)

The unique dial-knob assembly was constructed of brass-plated lid support or a flat piece of brass. See Fig. 4. Grind off the hinged support and put a black knob in its place. Select a knob with a brass insert and screw. Break and remove the plastic area of the knob. Epoxy the brass insert to the plated-brass piece. Grind down the end piece to a sharp point. Now, fasten the dial assembly to the shaft of the variable capacitor with the small knob screw.

Not only is Grandpa's Antique Radio easy to build, it's just plain fun with the added twist of the *good old days*—some sixty years ago. ■

The tubes are dummies in the author's model. If you wish, you can power up the tubes using a filament transformer and nothing else. The tubes will add color and heat like the old sets.

ELECTRONIC WIND CHIME— *HEAR MUSIC IN THE AIR. . .*

With this wind chime you can kick back and enjoy the gentle tinkling of the breeze; with the satisfaction of knowing you made it yourself. You build the instrument, and Mother Nature plays the tunes!

□HERE'S A MUSICAL DEVICE THAT YOU CAN BUILD, AND after a day of hard work or play, you can settle back and let Mother Nature's gentle breezes write and play the music for you. Our *Electric Wind Chime* music maker is a construction project that requires neither a special expensive IC, or any hard-to-find component; it can be built, with some junkbox searching, for only a few bucks. The Electronic Wind Chime is designed to hang indoors or outdoors where a mild breeze can make contact with the chime's paddle. Twelve different tones and their sequence, depend entirely on the whim of the flowing breeze.

How It Makes Music

A look at the circuit diagram in Fig. 1 will help to make the musical mystery clear. U1, a 555 timer, is connected in tone-generator fashion with R1, R2, and C1 through C6, setting the oscillator's tone frequency. Each of the six small reed switches are connected to a capacitor and diode pair, which set the oscillator's frequency and, at the same time, turn the power to the chimes circuitry on.

As shown in the photo, the wind paddle hangs down through the plastic pipe that S1 through S6 are mounted on. A doughnut magnet is attached to the upper end of the wind paddle and is spaced on the dowel to match up with the center of each of the vertically mounted reed switches. As long as the wind paddle remains motionless, all reed switches are normally open; but if a breeze moves the paddle far enough to activate one of the reed switches, power will be turned on and a tone will sound. Singularly activated reed switches account for six of the twelve different tones that the chime can produce; but if the magnet swings out far enough between two of the reed switches, both will close and a new lower tone will sound. That double closure produces the six additional tone outputs for a total of twelve.

A mini-toggle switch (S7) is included so that the chime's power can be turned off for storage or to stop the music. T1, a mini-transistor output transformer, is used to match the oscillator's output impedance to the speaker's low-impedance voice coil.

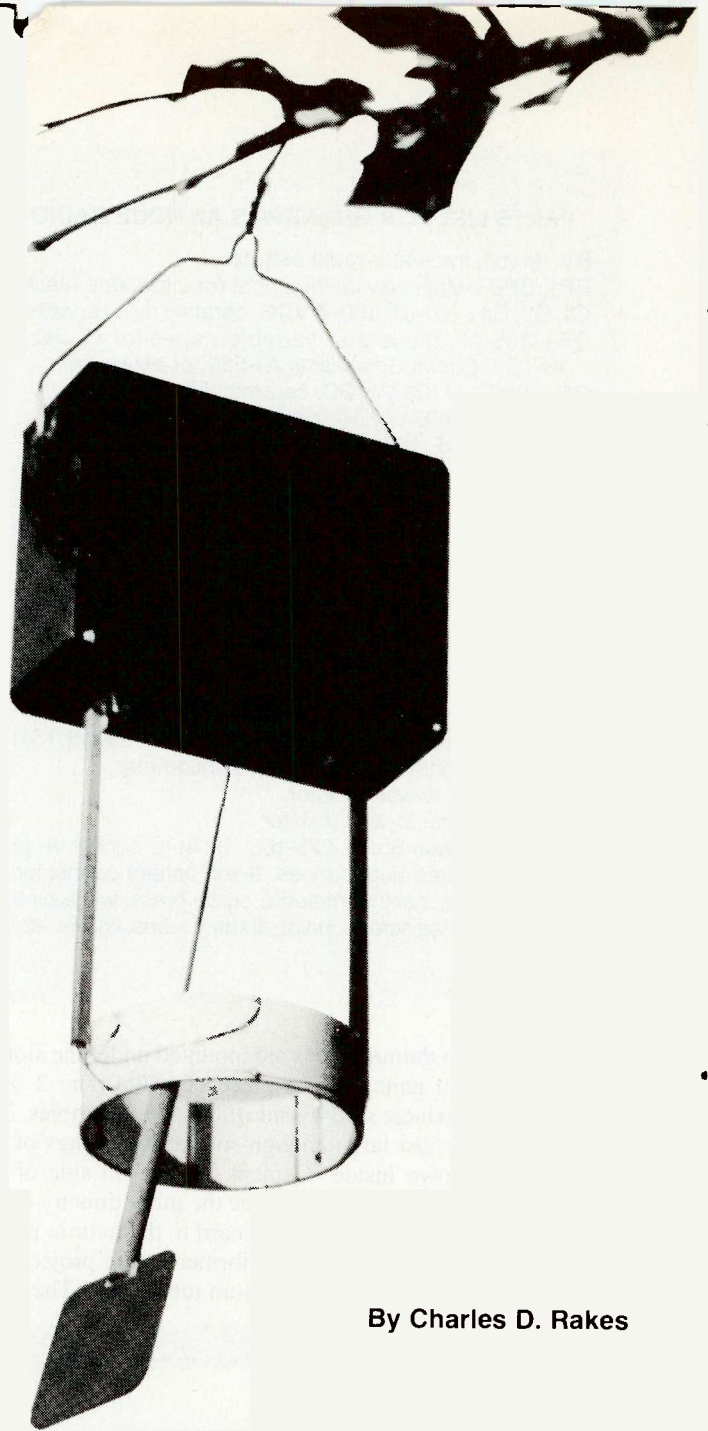

By Charles D. Rakes

Chime Up Your Own

The circuitry of the chime is housed in a $7 \times 5\frac{1}{4} \times 2\frac{1}{4}$ -inch plastic or Bakelite cabinet, but any similar enclosure of wood or metal will do. The majority of the circuit parts are mounted on a $2\frac{1}{2} \times 4\frac{1}{2}$ -inch section of perfboard. The six reed switches are mounted on a piece of $4\frac{1}{2}$ -inch plastic pipe cut to a length of 1½-inches (see Fig. 2).

Start construction by cutting a 12" section of ¼-inch square brass tubing into two equal parts. That type of brass tubing can be found in most hobby shops. Form two small 90° angle brackets from a piece of brass stock, and solder one to each of the brass tubes. Punch or drill a hole large enough to clear a 4-40 screw in the other side of the angle bracket. At the opposite end of each of the brass tubes solder a ¼-inch 4-40 flat-head screw, it will be used to secure the plastic pipe section in place.

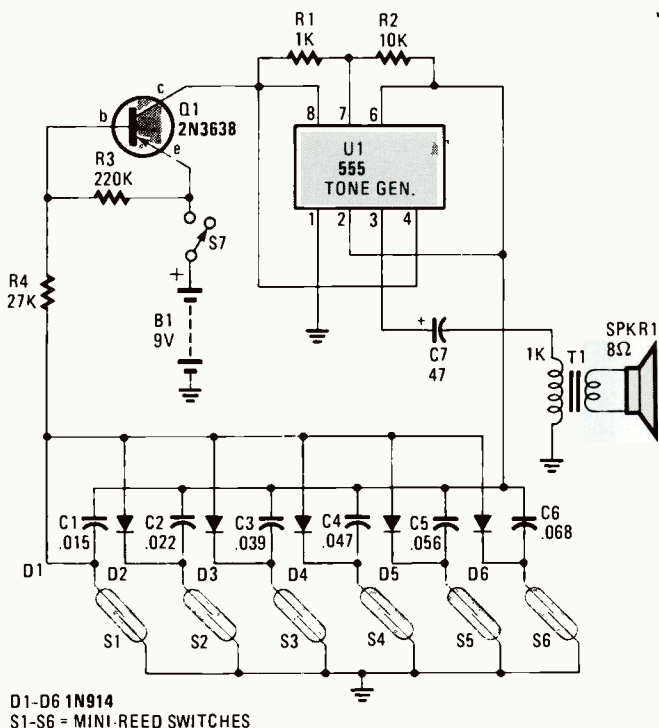

D1-D6 1N914
S1-S6 = MINI-REED SWITCHES

Fig. 1—The circuit uses little power and can be run off a 9-volt battery pack for a long time. As you can see, the circuit assembly is straightforward and inexpensive.

Cut off a 1½-inch piece of plastic pipe that will be used to mount the six reed switches. The switches are vertically mounted to the inside of the plastic pipe, equally spaced. Mark the piece of plastic pipe at six equally spaced locations around its circumference. Carefully bend both leads of a reed switch at a 90° angle so they point in the same direction. Bend all reed switches in like fashion, and position them parallel to the pipe's axis with equal distance between the top and bottoms of the pipe at the places marked. Drill two small holes to allow each lead of the switch to pass through to the outside of the plastic pipe. Push the leads through the inside of the pipe and bend them over to super glue to guarantee a permanent mount for each of the switches.

Mount the plastic pipe on the two brass tubes with the 4-40 hardware. Set the plastic pipe on a flat surface and position each of the brass tubes so that they are parallel to its axis and tighten them in place. The two brass tubes attached to the plastic pipe are mounted to the bottom of the plastic cabinet, so center them on the cabinet and mark the cabinet so that two mounting holes can be drilled. Also, while in that position, mark around each of the square tubes and drill a ⅜" hole in the center of the marked areas to match up with the openings of each of the brass tubes. These holes will be used to snake wire through later.

The perfboard, speaker, battery pack, and off/on switch can be positioned and mounted as shown in the photos, or any other workable arrangement. Actually the project is so uncomplicated that, if the reed switch and magnet arrangement are understood, almost any construction method, component layout, or cabinet choice can be used. Just suit yourself when building your Electric Wind Chime.

After completing the point-to-point component wiring of the circuit, attach the reed switch assembly to the cabinet with the 4-40 hardware. Connect all of the bottom leads of the

six reed switches together and run a wire up through one of the brass tubes and into the cabinet through one of the ⅜-inch holes. Connect it to the circuit common (battery negative). Attach a wire to the top terminal of each reed switch, and run three leads through one brass tube and the remaining three through the other, snaking them through the holes as before. Connect the six wires to the capacitor-diode pairs to match the schematic diagram.

The wind paddle is made by taking a 6½-inch length of wire cut from a coat hanger, a five-inch length of ⅞-inch diameter dowel, a doughnut magnet, and a small piece of circuit-board material all connected together as shown. Start by bending a nice "O" shaped hook in the top of the coat hanger wire, with an inner diameter of about ⅜-inch. Drill a hole about 1-inch deep in one end of the dowel a size smaller than the diameter of the hanger wire. Carefully work the hanger wire down into the hole and add a drop of Super Glue to the dowel where the wire meets the wood as added as-

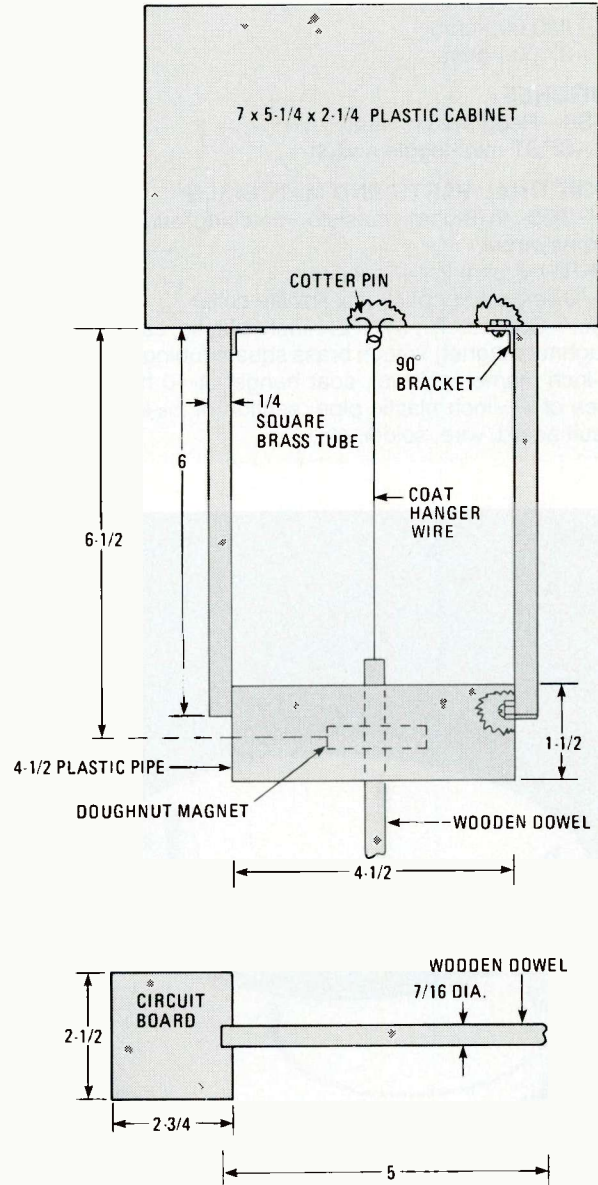

Fig. 2—The complete assembly of our model is shown here, but your wind chime need not be an exact copy. The cabinet type, size of hardware, and even the capacitor values can be up to you. Please note that the nuts and bolts used were all 4-40 size and that all dimensions shown are in inches.

PARTS LIST FOR THE ELECTRONIC WIND CHIME

SEMICONDUCTORS

D1-D6—1N914 silicon signal diode
U1—555 timer integrated circuit, 8-pin Mini-Dip
Q1—2N3638 PNP silicon transistor

CAPACITORS

(Select voltage rating for lowest cost)

C1—.015- μ F, mylar
C2—.022- μ F, mylar
C3—.039- μ F, mylar
C4—.047- μ F, mylar
C5—.056- μ F, mylar
C6—.068- μ F, mylar
C7—47- μ F, electrolytic

RESISTORS

(All resistors are $\frac{1}{4}$ -watt, 10% units)

R1—1000-ohm
R2—10,000-ohm
R3—220,000-ohm
R4—27,000-ohm

SWITCHES

S1-S6—Reed switch, small
S7—SPST mini-toggle switch

ADDITIONAL PARTS AND MATERIALS

T1—1000- to 8-ohm transistor-matching audio output transformer

SPKR1—8-ohm 2 x 4" speaker

B1—9-volt battery pack (six Penlite cells)

Misc.—Cabinet 7 x 5 $\frac{1}{4}$ x 2 $\frac{1}{4}$ -inch plastic cabinet, 1-doughnut magnet, $\frac{1}{4}$ -inch brass square tubing 12" long, $\frac{3}{16}$ -inch diameter dowel, coat hanger, 4-40 hardware, piece of 4 $\frac{1}{2}$ -inch plastic pipe, section of $\frac{1}{16}$ -inch thick circuit board, wire, solder, etc.



Be sure to bend and solder the leads for the reed switches before gluing them in place just in case one of them breaks. They should be evenly spaced around the plastic tubing and should not interfere with the mounting screws.

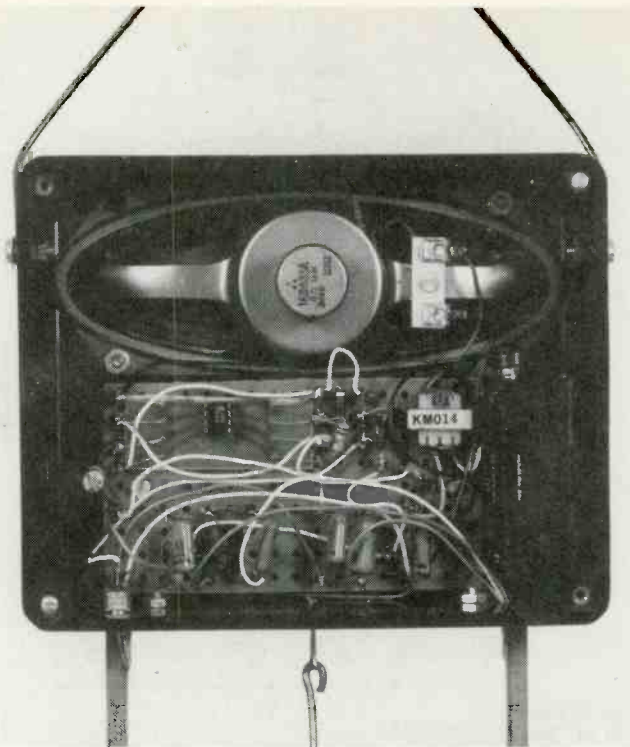

The assembly can be fitted neatly into almost any cabin you chose if you're inventive with the placement of the speaker and perf-board. The left-over portion of the coat-hanger can be used as a hook for the wind chime.

sure that the dowel and wire will stay put. Saw a $\frac{1}{2}$ -inch length slot in the opposite end of the dowel to hold the paddle in place. After inserting the paddle (circuit board) use a drop of super glue to hold it in the dowel.

In the center of the bottom of the cabinet (between the two brass tubes) drill a $\frac{1}{16}$ -inch hole. Place a small cotter pin through the hole with the round hook part sticking through the bottom of the cabinet. Hook the paddle assembly onto the cotter pin, which should swing freely in all directions, and mark the dowel at the centers of the reed switches. This should be done with the dowel moved toward the plastic pipe. This is to insure that the magnet will be placed high enough to activate a reed switch when it swings close to one.

The doughnut magnet should be positioned on the dowel over the center of the mark. If the hole in the center of the magnet is too small to pass over the dowel, then trim the dowel to a size where the magnet will just snugly fit in place, and once again use a drop of glue to hold it in place. Re-hook the wind paddle in place.

Most any method can be used to hang the completed chime, our choice was to use the remaining part of the coat hanger by attaching it to each side of the cabinet with the hook positioned over the center of the top of the cabinet. No matter how the chime is hung, it should be positioned in a balanced level condition so that the paddle and magnet are hanging straight down through the center on the 4 $\frac{1}{2}$ -inch section of pipe.

With the chime hanging in a breezy location turn the power on with S7, and you should begin to hear the fruits of your work playing a wind song just for you. If the tone frequencies are not in the range you would like to hear, just change the values of C1 through C6. Increase the values for lower tones and decrease the values for higher tones. Have fun! ■

ELECTRONIC DAZER

Never walk in fear with this one-evening project. It won't kill, but it's an effective way to say "Leave me alone!"

By Rick Duker

☐ THE *ELECTRONIC DAZER* IS A MODERN, PORTABLE, PERSONAL-protection appliance. It generates high potential energy to ward off vicious animals or other attackers. It is an aid to help escape from a potentially dangerous situation. The device develops about 2,000 volts. Higher voltages may be attained by adding additional multiplier stages, but it should be noted that those stages will also increase the overall size of the unit.

The Dazer is very compact, being built into a small plastic case. It is powered a single nine-volt battery, either NiCad or alkaline. The high voltage is applied to two electrodes which require only light contact to be effective. When touched with the Dazer, the victim will receive a stunning, but non-lethal jolt of electricity that will usually discourage any further encounters.

The Electronic Dazer is a power supply which consists of a micro-size regenerative amplifier/oscillator coupled to an energy multiplier section. It should not be confused with cheap induction-type cattle prods. The Dazer is more versatile than other high-voltage stun devices currently being sold. Those devices are basically high-voltage, AC generators which jam the nervous system. However, the Dazer may be used for heating and burning applications, or anywhere a high voltage DC supply is required.

How It Works

Referring to the schematic diagram in Fig. 1, the two power transistors Q1 and Q2, form a regenerative amplifier operating as a power oscillator. When Q1 turns on, Q2 turns on and that shorts the power supply across the primary of T1. That current pulse induces a high voltage in the secondary of T1. As C1 charges, Q1 turns on again and the cycle repeats itself. Therefore, a rapid series of DC pulses are generated and stepped up by T1 to approximately 300 volts at full battery

Fig. 1—As you can see, although the Dazer is not complex, it contains enough doubler circuitry to pack quite a punch. The oscillator does nothing more than send sharp current pulses through T1. The back EMF across the secondary winding is then pumped through the multiplier stage to produce the very-high output voltage across the electrodes.

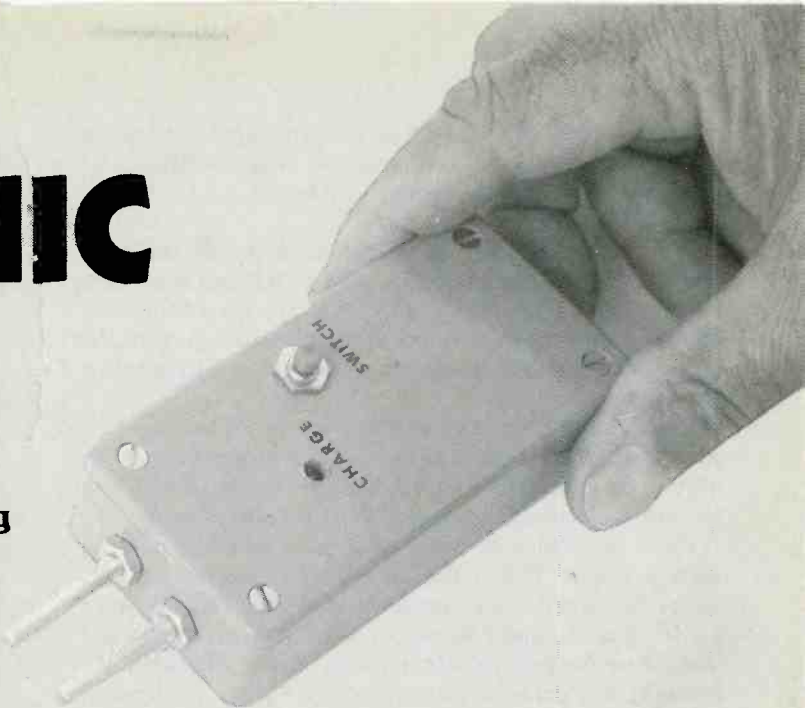

WARNING

THIS DEVICE IS NOT A TOY. We present it for educational and experimental purposes only. The circuit develops about 2000 volts at a respectable amperage. It can cause you pain and even damage if you become careless and touch its output terminals. The unit can also damage property as well so use it wisely.

You should never use the device on another person! It may not be against the law to possess such a device in your area, but if you use it on someone you may be deemed liable in a civil and/or criminal action suit. Don't just follow the golden rule after constructing the project, instead just don't do unto anyone.

Included in the article are a number of instructions on how to build, test, and operate the Dazer; all of them must be followed to the letter. Do not deviate from the procedure.

charge. That voltage is rectified and increased by the voltage multiplier section which consists of C2 and C9, and D1 to D8. The final output is approximately 2000 volts. The neon bulb NE1 is used as a charge indicator and indicates that the unit is charged and operating properly.

Construction

As with all projects start out by laying out and identifying. If you do not wish to make a printed-circuit board, then you

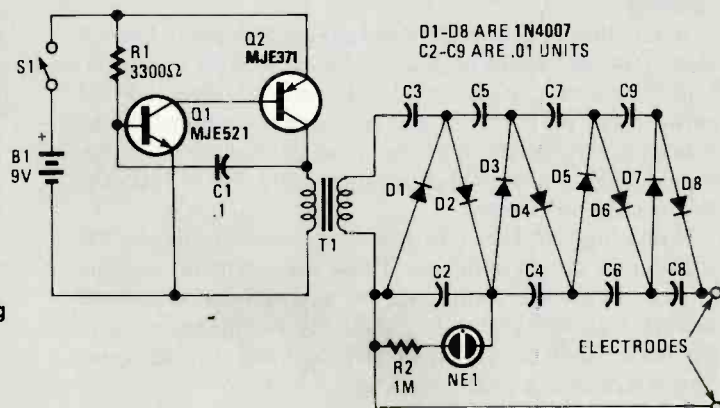

may use a perf board as long as you remember to keep the leads of all high-voltage components isolated. That is to prevent sparks from arcing across your board. A 4 x 7.5 cm of perfboard is suitable for that purpose.

The first components you should mount are the two transistors Q1, Q2, transformer T1, resistor R1, and neon bulb NE1. Solder them in place (for PC construction) being sure that the transformer and transistors are hooked up correctly. Apply a small amount of adhesive to the base of NE1 to hold it securely in place.

Mount D1 to D8 and C2 to C9 on the board and make all solder connections. Note proper polarity of the diodes. The off-board components come next. Solder in leads for S1, and the output electrodes. Also solder in the battery clip for B1.

Build the enclosure from some nonconductive material such as plastic. Drill holes for S1, NE1, and output electrodes. Be sure that the output electrodes are about a cm or greater apart. Connect the output wires to the electrodes and insert them through holes from inside of case. Thread on the retaining nuts and tighten them securely. Set the circuit board in the case and mount S1, securing with nut. That completes the construction.

PARTS LIST FOR THE ELECTRONIC DAZER

- C1—0.1- μ F monovac capacitor
- C2—C9—0.01- μ F 400 volt polyester capacitors
- D1—D8—1N4007 1-kV diode
- NE1—Type NE-2 neon bulb
- Q1—MJE521 NPN power transistor
- Q2—MJE371 PNP power transistor
- R1—3,300-ohm $\frac{1}{4}$ -watt resistor
- R2—1,000,000-ohm $\frac{1}{4}$ -watt resistor
- S1—SPST momentary-contact, pushbutton switch T1—1200 to 8-ohm audio power transformer

ADDITIONAL PARTS AND MATERIALS

9-volt battery clip, 10 x 5 x 2.5-cm plastic case, 7.5 x 4-cm perfboard or PC board, two $\frac{3}{32}$ x 1- $\frac{1}{4}$ bolts and nuts for electrodes, adhesive for mounting NE1, circuit board standoffs (optional), hookup wire, solder, etc.

The following are available from Quantum Research, 17919-77th Avenue, Edmonton, Alberta, Canada T5T 2S1:

- QV100K1—Complete kit without PCB (includes all above parts except those following the electrodes in the above list) \$40.00 (includes postage).
- QV100K2—Complete kit with PCB (includes all above parts except those following the electrodes in the above list) \$45.00 (includes postage)

Testing

Before inserting the battery and closing the case, a few test measurements should be made to ensure correct operation. With the ground clip connected to the battery, connect a VOM between the positive clip and the positive terminal of the battery. Set the meter for current reading, and press S1. You should measure a current of approximately 300 to 500 mA. NE1 should be glowing.

With a high voltage VOM, you should measure about 2000 volts on the output terminals. Those measurements indicate proper circuit operation. Let the unit run for about one minute. Transistors Q1 and Q2 should be warm, but not hot to the touch. Insert the battery in the holder and close the case. That wraps up the Electronic Dazer.

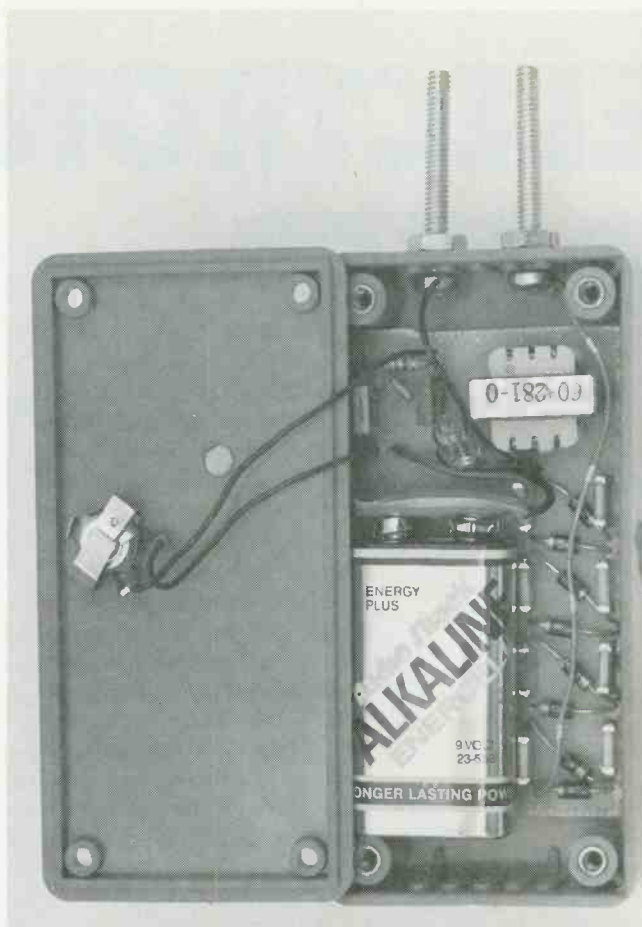

Good parts layout is the secret to any miniature project. If your layout causes the battery to come too close to the high-voltage components we suggest you insulate it with tape.

Operation and Use

Activate the unit by pressing S1. NE1 will light indicating the dazer is fully charged and ready to use. Notice also that only one pole of NE1 will glow indicating DC voltage present. It is important to remember that the device holds a charge even after S1 is off. To discharge, touch the electrodes to a metal object and note the healthy spark discharge.

The Electronic Dazer was designed as a self-defense weapon for use against vicious dogs or other attacking animals. The device is most effective when the electrodes contact an area of low resistance such as skin or flesh. Those include the snout or mouth since the resistance of those areas are much lower than areas of hair or fur. The electrodes could be pointed to penetrate these areas better. The dazer generates great stopping power. One contact will give a powerful jolt and should discourage any further attacks.

The device can burn and heat materials with low resistance. Those include flesh, moistened paper or wood, etc. That makes the unit potentially hazardous to humans. Remember, the dazer is not a toy but a quality electrical appliance and therefore must be treated accordingly. Use the utmost discretion with this device.

Another use for this device is as a high-voltage DC power supply. It may be constructed as a variable power supply if output taps are taken from various stages of the voltage multiplier section. Remember, always disconnect the battery and fully discharge the capacitors before working with the circuitry.



THE WATERBUGG ALARM

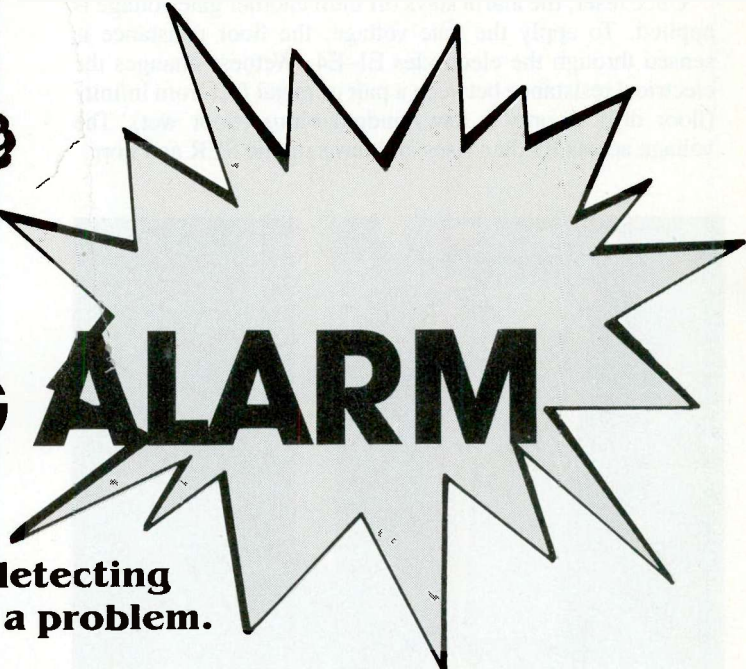

This inexpensive circuit helps prevent costly flood damage by detecting the condition before it becomes a problem.

By Dave Sweeney

□ BASEMENT WATER-DAMAGE COMES AS A SURPRISE BECAUSE a flood makes no noise as it oozes into an area and makes the padding underneath recreation-room carpeting soggy. Usually, the water leaks from the utility room—from the hot water heater as it ages and springs tiny leaks, or the clothes washer when a sock or handkerchief blocks the drain sink. Cold weather sometimes cracks a pipe—again creating quite a mess if no one discovers that water is dripping to the floor. After a while, the water flows under walls and into adjacent rooms, where the damage can become quite expensive; and if lights or appliances are present, an electrical hazard could evolve.

Moisture Sensing

To sense the presence of wetness on the floor, you can build a compact water sensor and alarm that uses almost no battery power while it monitors the surface, and sounds a loud pulsating alert at the first sign of wetness. The 5 inch by 5 inch plastic module sounds an alarm for hours to draw attention to the wet floor. Small, and using no external wires or sensors, the alarm hides under a hot-water heater, a kitchen sink, in the bathroom, or any other place where a wetness problem might occur.

Designed for *set it and forget it* operation, the *Waterbugg* incorporates waterproof packaging (nothing more than a readily available plastic enclosure) that keeps the electronic circuit high and dry for years. In addition, the circuit draws almost no current because the only power consumption is due to the leakage through a single, reverse-biased SCR (Silicon-Controlled Rectifier). Measured in microamps, current drain amounts to almost nothing as long as the floor remains dry. The biggest problem that you'll have to contend with is remembering to change the batteries after about two years, provided that you haven't suffered a wetness problem.

The parts for the Waterbugg will cost less than eight dollars, and you can put the circuit together in less than 90 minutes. Once built, the Waterbugg is easily tested outside the house by simply placing it on the sidewalk and tossing a glass of water toward the alarm. When the water wets the concrete under the plastic box, the alarm will sound. A reset button will stop the alarm and make it ready for the next time.

About the Circuit

Refer to Fig. 1. To sense wetness, the alarm depends on the switching action of SCR1—which conducts only in one direction and only after experiencing a positive voltage on its gate with respect to its cathode.

Once turned on, SCR1 stays on and disregards any change in the gate voltage. (Even if the leak stops, or if the flow changes direction, the alarm continues to indicate that a problem has occurred.) Switching SCR1 on, connects a piezo

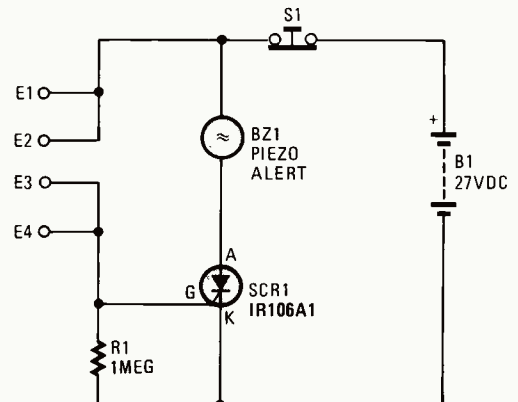

Fig. 1—The circuit, though consisting of very few components is capable of a variety of applications. For example, as it is, the circuit might be used as a continuity tester.

alert (BZ1) to three series-connected 9-volt batteries, applying 27-volts DC to BZ1. S1 (a normally closed, pushbutton switch) resets the circuit, by interrupting current through SCR1.

Once reset, the alarm stays off until another gate voltage is applied. To apply the gate voltage, the floor resistance is sensed through the electrodes E1-E4. Wetness changes the electrical resistance between a pair of metal feet from infinity (floor dry) to only a few hundred ohms (floor wet). The voltage across R1 then rises and turns on the SCR and horn.



The Waterbug can be placed anywhere that flooding is likely to occur; under a water-heating unit or in the laundry room, etc.

Construction

Since, the alarm will sit in an out-of-the-way place for extended periods of time, for continued effectiveness, the circuit requires rust-proof electrodes and a watertight case. The first requirement is fulfilled by metal strips cut from a thin sheet of aluminum (sold at hardware stores) and used for the Waterbug electrodes (E1-E4). Each 3-inch by 1/2-inch strip is folded after mounting to the plastic case (see photos). The case, impossible to tip over accidentally, rests on the four aluminum feet, which, in turn, solidly contact the floor despite irregularities.

The plastic case, readily available in supermarkets, is the type used to keep sandwiches fresh. And because it is air and moisture tight, it's just the thing for the floor environment; it

PARTS LIST FOR THE WATERBUG

- B1—27-volt DC (3 9-volt transistor-radio batteries)
- BZ1—Piezo alert alarm (Radio Shack 273-066)
- R1—1-Megohm, 1/4-watt, 5% resistor
- S1—Single-pole, single-throw, normally-closed push-button switch
- SCR1—IR106A1 (or similar) silicon-controlled rectifier

ADDITIONAL PARTS AND MATERIALS

Printed-circuit (or perfboard) material or barrier strip, aluminum sheeting, enclosure, epoxy, wire, solder, etc.



An ordinary plastic sandwich box—which can be found at drug and variety stores, or supermarkets—is used to house the series-connected batteries and components that make up the circuit.

also provides an easy-to-drill cabinet for the piezo alert and the reset switch.

The circuit itself can be put together by using any construction method desired—on a barrier strip or perfboard, using point-to-point wiring, or on a printed-circuit board. The choice is yours. After the R1 and SCR1 connections are soldered, epoxy them to the alert, and your project is ready for testing. Simply place the unit on the ground and toss a glass of water at it. As the water saturates the ground beneath the unit, placing a short across the E1/E2 and E3/E4 terminals, the alarm should go off. If it doesn't, check the wiring of the components—probably the only way to screw up the circuit is to wire the SCR the wrong way; that is, assuming that you haven't gotten hold of a defective component.

Other Uses

The circuit has other practical uses, the most obvious being, as a continuity tester (without modification). Or try removing the Piezo alert and connecting the Waterbug to an AC control circuit, that's attached to a water pump. In that way, when you're away from home and flooding occurs, the pump will be triggered into operation—preventing water damage. You can also connect the Waterbug to a magnetic switch, allowing the circuit to function as a door- or window-open indicator. Or add a mercury switch and you've got yourself a tilt indicator (very similar to the *Ultimate Burglar Alarm*, which appeared in the Sept/Oct issue of *Hands-on Electronics*). As you can see, the circuit's applications are limited only by your imagination. And best of all, it's cheap!

AC Power

Although the batteries will last their shelf life because no current is drawn until the alarm goes off, you might want to ensure the alarm's reliability by substituting a "117 VAC-to-24 VDC battery-eliminator" adapter for battery B1. The unloaded output from the adapter is about 27 volts, so the project will work just fine. ■

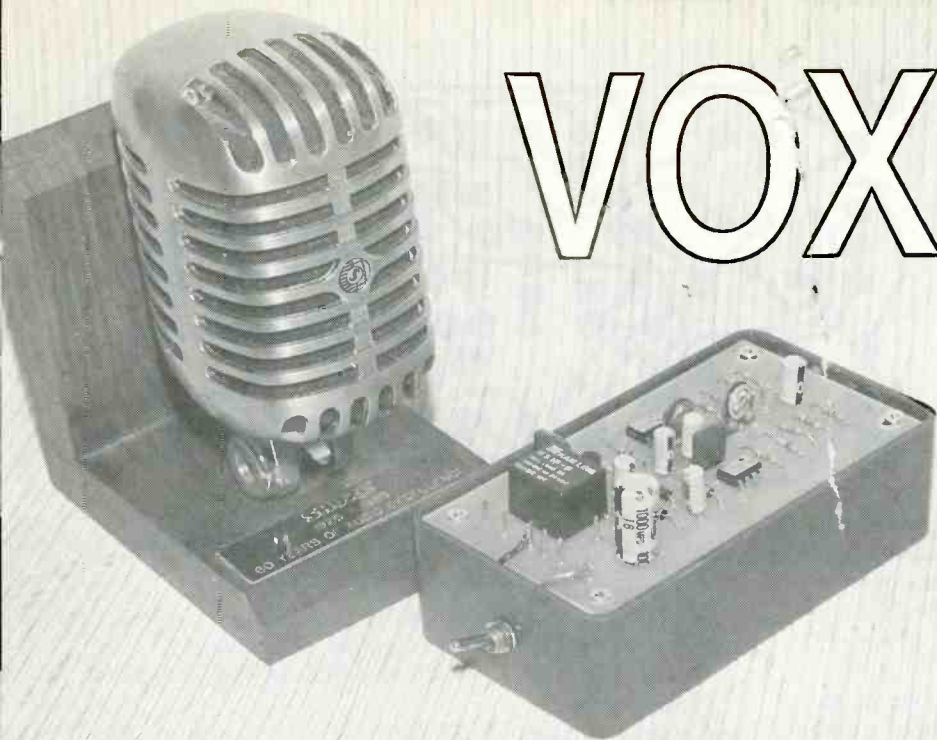

VOX BOX

Voice-operated relays (VOX) are a thing of the past now that semi-conductors have taken over! But VOX is too good a term and concept to relegate to antiquity!

By Jay Glowacki

THERE IS NO WAY TO PROVE BEYOND DOUBT THE TRUTH of the following statement: Radio amateurs popularized the *voice-operated relay* by use of those devices and the catchy name "VOX." Those early radio buffs were the first modern electronics experimenters; far be it for us, their successors and heirs, to allow the term VOX to fall into non-use.

Thus our plan is obvious. This article presents an easy-to-build voice-operated project—which we call the *VOX Box*—that can be used for a variety of purposes about the home and work area. VOX Box is a multi-functional voice-operated relay device. It can be used to control a tape recorder, switch on an amateur transmitter, or control a slide projector. It can be used with any low- or high-impedance microphone, or a high-level audio source such as a pocket tape recorder.

You may be familiar with the press-to-talk communications microphones used by PA system and amateur-radio

operators. The VOX Box avoids the need to depress the press-to-talk switch every time the announcer or operator speaks. When the VOX Box controls a tape recorder, it eliminates long gaps of background hiss when the program material is missing. I could continue on and on about the virtues and applications of the VOX Box, but then we will never get down to the construction details.

Circuit Description

The electronic circuit in VOX Box consists of three parts (see Fig. 1): a microphone preamplifier, a Schmitt trigger, and a relay driver. Input signals (MIC INPUT terminals) to the microphone preamplifier (U1) are amplified and fed to a THRESHOLD control (R8). When the preselected threshold voltage level is exceeded, the output of the Schmitt trigger (U2) immediately goes high. The signal from U2 is rectified and the voltage developed across C7 turns on the relay-

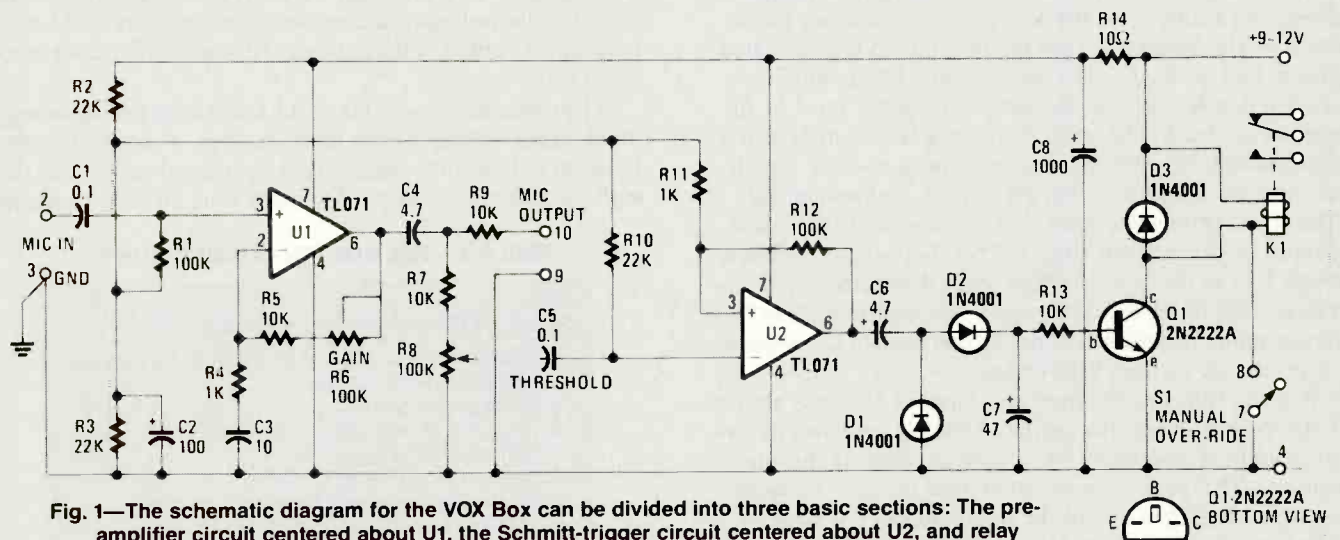
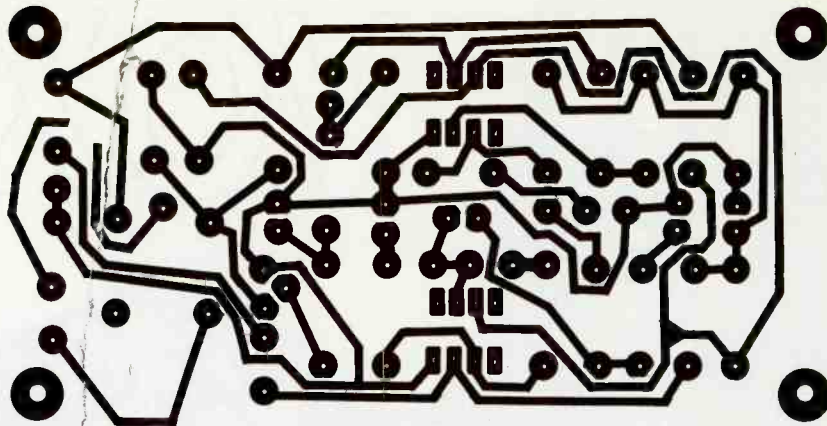

Fig. 1—The schematic diagram for the VOX Box can be divided into three basic sections: The pre-amplifier circuit centered about U1, the Schmitt-trigger circuit centered about U2, and relay driver/relay circuit centered about Q1 and K1. The microphone preamplifier circuit may not be needed in some applications and it may be omitted. Refer to Fig. 4 for details.

Q1: 2N2222A
E BOTTOM VIEW

Fig. 2—Copy this same-size template to make your printed-circuit board of the VOX Box. Should you decide to use a perfboard, insert flea clips where component leads would enter the PC board. Then hard wire everything.



energizer transistor (Q1). That transistor action passes pull-down current through the coil of relay K1. The changing of the relay STDP contacts can be used to either make or break an external AC or DC circuit.

The Bottom Line

The above is a simplified signal-flow discussion of the VOX Box circuit operation. You could skip ahead to the construction portion of this article or continue reading for a more detailed circuit analysis in the following paragraphs.

Chip U1, (a Texas Instrument TL071 integrated-circuit op-amp) functions as the microphone preamplifier. It is connected as an inverting amplifier with AC signal gain that is variable between 10 and 110. A potentiometer (R6) in the feedback circuit provides the means to vary the gain.

The preamplifier's frequency roll-off below 20 Hz is set by capacitor C3, which also sets the DC gain of the preamplifier at unity.

The MIC IN signal from the microphone is coupled by capacitor C1 to the non-inverting input of U1. A voltage divider consisting of R2 and R3 sets the bias to the non-inverting input of U1 and to both inputs of U2 to half the battery supply voltage so that those two op-amps can operate at the same bias voltage. Decoupling of the voltage divider is provided by capacitor C2.

The output signal from U1 is coupled by C4, R7, R8, and C5 to the input of the op-amp Schmitt trigger. The reason for selecting a large value capacitor for C4 is to provide adequate audio-signal coupling to the MIC OUTPUT terminals via resistor R9. The Schmitt trigger requires only a differentiated signal to kick it off, so C5's value is small by comparison. Potentiometer R8 adjusts the threshold signal level to the trigger as desired by the user. The microphone output signal passes through R9; that signal can be used to drive a high-level input on a tape recorder, PA system, transmitter, etc.

The signal from potentiometer R8 is coupled to the inverting input of the Schmitt trigger (U2). A positive feedback through R12 to the non-inverting input determines the hysteresis activity of the Schmitt trigger. For small signals to the inverting input, there is no AC output and pin 6 of U2 remains at its prior state—either high or low.

When the signal to the inverting input of U2 rises above .07-volt peak-to-peak, the output of the U2 switches to the stage's limiting condition—a *squareish* wave at the input frequency. The peak-to-peak amplitude of the "squared" wave is just less than that of the power supply's voltage.

The output signal from U2 is rectified by a half-wave, voltage-doubler consisting of diodes D1 and D2; capacitor C7

PARTS LIST

SEMICONDUCTORS

D1-D3—1N4001 1-A, 50-PIV silicone rectifier diode
Q1—2N2222A general-purpose NPN transistor
U1, U2—TL071 low-noise, BIFET op-amp, integrated circuit

RESISTORS

(All fixed resistors are 1/4-watt, 5% units unless otherwise noted.)

R1, R12—100,000-ohm
R2, R3, R10—22,000-ohm
R4, R11—1000-ohm
R5, R7, R9, R13—10,000-ohm
R6, R8—100,000-ohm trimmer potentiometer, PC mount
R14—10-ohm

CAPACITORS

C1, C5—0.1- μ F, Mylar
C2—100- μ F, 16-WVDC, PC-mount, electrolytic

is then charged. The voltage across C7 raises the bias supplied to transistor Q1, causing Q1 to turn on. The current passing through Q1 energizes the coil of relay K1, and the relay's armature (the movable part of the switching contacts) makes the external circuit.

Rectifier diode D3 reduces inductive kickback developed across the coil of K1 to almost zero. If spike quenching were not done, the voltage spike created to maintain the suddenly-interrupted current in the coil could destroy relay-driver transistor Q1.

If you were to measure the attack time (from first activating input-signal voltage rise to relay closing), it would measure between 8-14 milliseconds. The time interval varies with the audio signal's rising slope. The delay time for relay drop-out

TABLE 1—VOX BOX PIN CONNECTIONS

Pin No.	VOX Box Circuit Connection
1	Positive power-supply connection (9-12 volts DC)
2	Microphone input signal
3	Microphone ground
4	Negative power-supply connection
5	Armature on relay contacts
6	Normally-open relay contact
7	Manual override switch connection (gnd)
8	Manual override switch connection (hi)
9	Preamplifier output ground
10	Preamplifier output signal

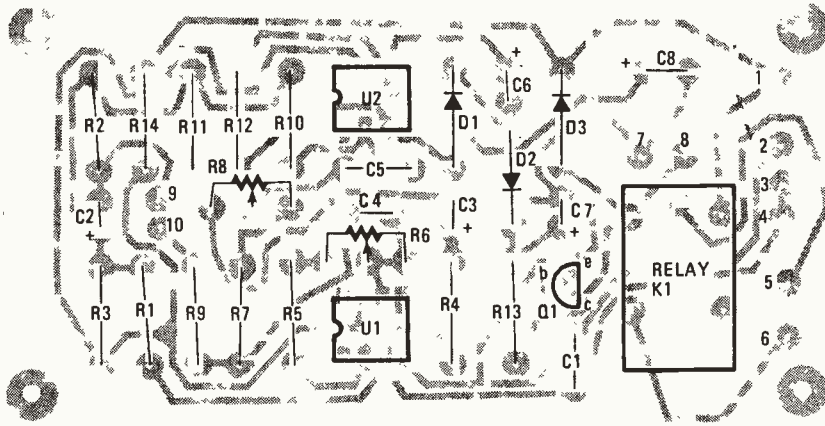

Fig. 3—The diagram locates parts on the printed-circuit board while showing an X-ray view of the board's foil leads in color. The relay purchased with the kit mentioned in the Parts List fits the predrilled holes in one position only.

FOR VOX BOX

- C3—10- μ F, 16-WVDC, PC-mount, electrolytic
- C4, C6—4.7- μ F, 16-WVDC, PC-mount, electrolytic
- C7—47- μ F, 16-WVDC, PC-mount, electrolytic
- C8—1000- μ F, 16-WVDC, PC-mount, electrolytic

ADDITIONAL PARTS AND MATERIALS

- K1—Relay, miniature, SPDT, 12-volt coil
- S1—switch, SPST, toggle (optional—see text)
- Printed-circuit board, PC pins, experimenter's plastic chassis box—4 $\frac{1}{8}$ -in. long \times 2 $\frac{1}{2}$ -in. wide \times 1 $\frac{1}{2}$ -in. high (see text), transistor-radio battery or wall power-plug pack, wire, solder, etc

A complete kit of parts, including a pre-etched printed-circuit board and all the necessary components, for the VOX Box is available (priced at \$15.00, plus \$2.00 shipping and handling) from Imtronics Industries Ltd., 11931 31st Court, St. Petersburg, FL 33702. Please allow 6 to 8 weeks for delivery.

(from last activating input-signal voltage rise to relay de-energizing and the releasing of the armature) should be adjusted to 1 to 5 seconds by potentiometer R8. People who pause a lot while speaking should have the latter setting. Rapid speakers require less relay drop-out time.

What causes transistor Q1 to drop-out the relay is the discharge of capacitor C7; that loss of charge reduces the DC bias on the base of Q1. The larger in value capacitor C7 is, the longer the time it takes to discharge through R13 and the base-to-emitter resistance of Q1.

Manual override is provided by a SPST switch (S1) wired across the relay-driver transistor, Q1. Closing S1 connects the coil of K1 directly across the power supply, keeping it energized until the power is removed or S1 is opened.

The method of powering the circuit is dependent on the materials on hand and the circuit's application. A surplus plug-in power-supply pack rated at 9–12-volts DC at 200 mA is more than adequate. (See our comment about battery use at the end of this article.)

Putting It Together

The best assembly method for the VOX Box is to use the pre-etched, printed-circuit board (see Parts List) and kit of parts that are available. Assembly time will be only one evening—this writer took three hours, which included picture taking and circuit measurements. Another way to go is to make your own circuit board and buy only those parts that are missing from your junkbox inventory. If that is the case, make your printed-circuit board from the same-size circuit pattern shown in Fig. 2.

The next obvious step is to mount the parts onto the board using a low-wattage soldering iron. Take care that the positioning of polarized parts, such as integrated-circuit chips, diodes, and electrolytic capacitors are done correctly. The relay pins permit mounting of K1 only one way (the correct way). Refer to Fig. 3 for parts-placement information.

The sequence of soldering parts to any printed-circuit board is simple to understand: First connect those parts that are rugged and not damaged easily. Those parts are resistors, capacitors, relays, terminals, most coils, sockets, jumpers, etc. The parts that are mounted last are diodes, transistors, integrated-circuit chips, and fragile parts that break easily. In some rare instances, large components are mounted last no matter how rugged they are, because they block access to mounting holes in the board for parts that are located underneath or near by. With that in mind, assemble the printed-circuit board by first mounting the resistors, terminal pins, diodes, potentiometers, capacitors, relay, transistor, and

(Continued on page 156)

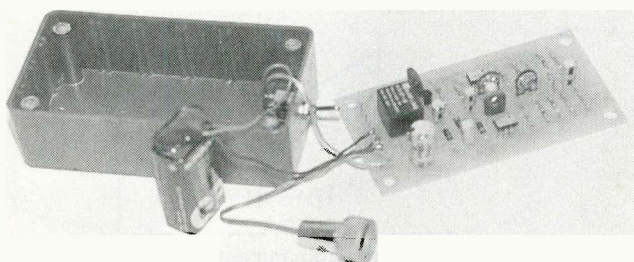

The VOX Box was mounted on a plastic box for testing purposes. The 9-volt DC transistor-radio battery resides inside the box and the power switch (not shown in Fig. 1) is on the box's side panel. The output from the preamplifier is not used, nor is the override switch S1 connected. The latter was not required—it is optional. The audio-type connector in the photo was used to connect and test the VOX Box circuit operation with several standard microphones.

ALL-BAND FIELD ST

An FSM is the most reliable indicator that a CB or amateur station is really putting

□ IN THIS AGE OF DIGITAL GIZMOS AND WHATSIT'S THAT measure everything with an accuracy out to the umpteenth decimal place, the old-fashioned FSM (*Field-Strength Meter*) is still the most-reliable indicator of RF energy for CB and amateur transmitters and antennas. The reason it's the most reliable indicator is because an FSM indicates *radiated RF energy*. It doesn't tell you anything about the standing-wave ratio, transmission-line losses, the transmitter's efficiency factor, or anything else other than how much relative RF energy is being sensed at the meter's location. If you can increase the amount of energy radiated from the antenna, the FSM's reading will similarly increase. If the energy leaving the antenna decreases, the FSM's reading will similarly decrease. If you're using a directional beam and you swing it around so that the FSM is now off the back of the antenna, the meter reading should decrease—or you have a **BIG problem** with your antenna.

If someone talks you into blowing a week's wages on a new kind of low-loss transmission line, and the FSM—at the reference location—indicates no, or very little change in field strength, figure you most likely would have been better off wasting the money on wine, women, and song.

Its Usefulness

Since an FSM is sensitive only to the relative amount of radiated RF, it's an ideal indicator for almost any kind of transmitter or antenna adjustment that affects how your rig gets out. For example, let's assume that you have purchased one of those new pocket-size, quick-mount mobile-CB antennas that claim to outperform any "full-length" antenna. If you just swap antennas, the best you can hope for is some good buddy saying something to the effect that your new signal *appears* to sound louder today than it did a few days ago. Since the ear

is a notoriously poor judge of signal strength, and also because a receiver's AGC (Automatic Gain Control) will automatically equalize moderate to strong signals, a signal report from anyone receiving your signal when it's stronger than a flea's whisper is worthless.

On the other hand, look what an FSM will do for you. If it's a super-sensitive model, such as the one shown in the photographs, you set it up well out of range of the antenna's "shock field." (Say a quarter to a half a block away). You leave your old antenna on the Detroit Iron, key the transmitter, and note the meter reading. (Use binoculars if your vision isn't all that good, or have someone else read the meter.) Next, you install the new antenna and tune it; first following the supplied instructions on adjusting the antenna for lowest VSWR, and then tweaking the antenna tuning adjustment for the highest (strongest) reading on the FSM. If the new antenna is truly a better performer, the FSM's reading should be higher than it was for the old antenna. If it isn't, either you have done something wrong, or have made a poor choice (a nice way of saying you've been "taken").

You will most likely be surprised to discover that the lowest VSWR might not correspond to the highest FSM reading. Within reason, always go for the highest FSM reading when adjusting an antenna or tuning a transmitter: Low VSWR readings and minimum RF-output current don't necessarily guarantee maximum RF output. As long as the antenna and final-amplifier parameters are within their safe or rated range, use an FSM indicator when optimizing RF output.

Two Kinds

There are basically two kinds of field-strength meters: tunable and untunable. Both types are available in amplified and unamplified models. Both types have their advantages and disadvantages. The basic tunable FSM circuit is shown in

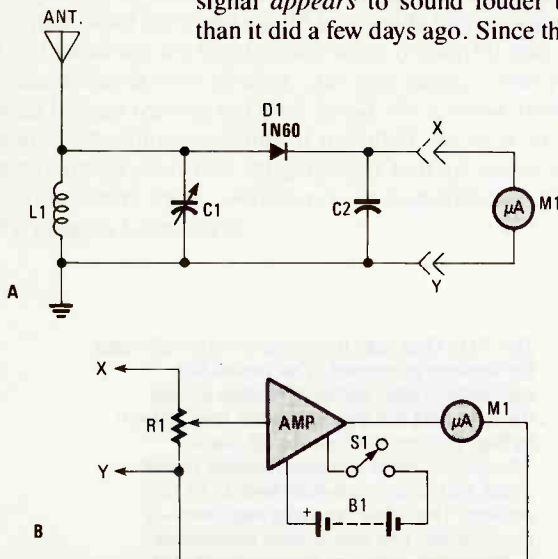

Fig. 1—The basic tuned FSM circuit is shown in 1A. The amplified meter in 1B sharply increases overall sensitivity.

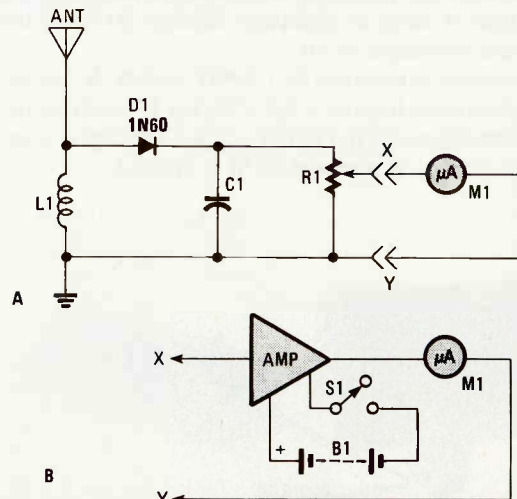

Fig. 2—An untuned field-strength meter is shown in 2A. An amplified version of the meter module is shown in 2B.

RENGTH METER

out the soup!

By Herb Friedman

Fig. 1A. Coil L1 and variable capacitor C1 comprise a tuned circuit at the operating frequency of the transmitter or RF source. Naturally, a high voltage (at extremely low current) is developed across L1-C1. The RF voltage is rectified by D1—which should be a germanium diode such as the 1N60 because its breakdown voltage is less than that of a silicon diode. The RF is filtered by C2, a small capacitor whose value is usually .001 μ F below 30 MHz, or 100 pF from 30 MHz to 148 MHz. The resultant DC appearing across C2, which is proportional to the amount of RF received by the antenna, is indicated by meter M1.

If the signal is so strong that the meter pointer is “pinned,” the sensitivity can be reduced by detuning C1. Unfortunately, in order to get any decent amount of sensitivity, meter M1 must be a 0–50 μ A or a 0–100 μ A model, both of which are rather expensive.

It's often much less expensive to use the circuit shown in Fig. 1B—a DC amplifier driving a less sensitive 0–200 μ A or a 0–500 μ A meter. The amplified meter is connected at the points labeled X and Y. The amplifier usually makes the overall sensitivity so great that tuning-control C1's adjustment becomes excessively critical, and literally breathing on its shaft will “pin” the meter. Instead, we use R1 as a “volume” control for the amplifier. It provides a broad range of adjustment.

Untuned FSM

A basic untuned FSM is shown in Fig. 2A. Essentially, the tuned circuit has been replaced by L1, an RF choke. (It's also possible to use a 10,000- or 20,000-ohm resistor instead of L1.) As you might imagine, the RF voltage developed across the choke is considerably less than that developed across a tuned circuit, so meter M1 must be extremely sensitive: 0–50 μ A is almost a universal value. But even with so sensitive a

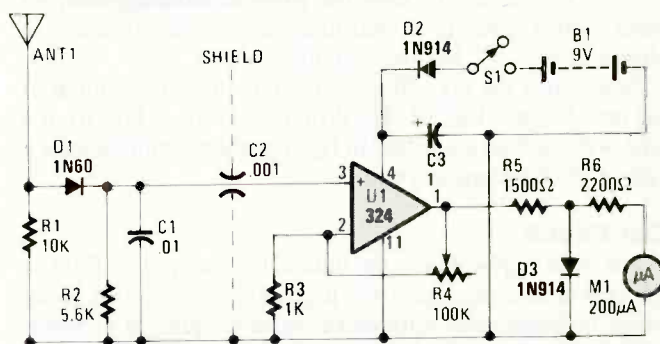
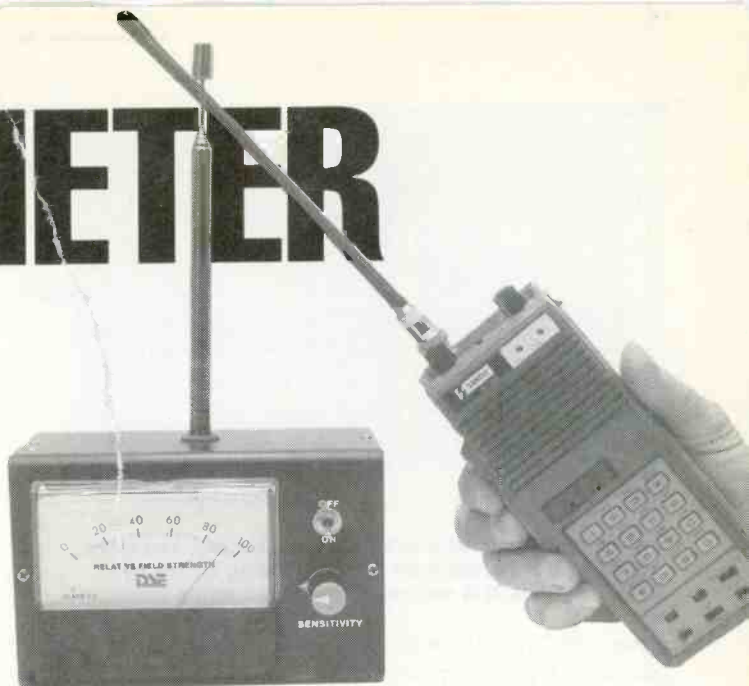

Fig. 3—This is the untuned, super-sensitive FSM. Capacitor C2 can be a conventional axial-lead ceramic capacitor instead of the feed-through type used in the circuit.



The Field-Strength Meter Kit is an old-fashioned type. Nothing is pre-assembled. Even the meter's special pre-calibrated scale must be installed by the builder.

PARTS LIST FOR THE ALL-BAND FIELD-STRENGTH METER

SEMICONDUCTORS

- D1—1N60 germanium diode
- D2, D3—1N914 silicon diode
- U1—LM324 quad op-amp, integrated-circuit

CAPACITORS

- (All capacitors rated 16-WVDC minimum.)
- C1—0.01- μ F ceramic disc
- C2—0.001- μ F feed-through, see text
- C3—1- μ F, Tantalum

RESISTORS

- (All fixed resistors are 1/8-watt, 10% units.)
- R1—10,000-ohm
- R2—560-ohm
- R3—1000-ohm
- R4—100,000-ohm trimmer, audio, or liner potentiometer
- R5—1500-ohm
- R6—2200-ohm

ADDITIONAL PARTS AND MATERIALS

- ANT1—Telescopic antenna
- B1—9-volt battery
- M1—200- μ A DC meter
- S1—SPST switch

Cabinet, wire, solder, printed circuit materials.

A complete kit of parts except for B1 (order #K-6321) is available for \$39.95 from Dick Smith Electronics, PO Box 8021 Redwood City, CA 94063. Phone 800/332-5373 for details and shipping information. Please allow 6-8 weeks for delivery.

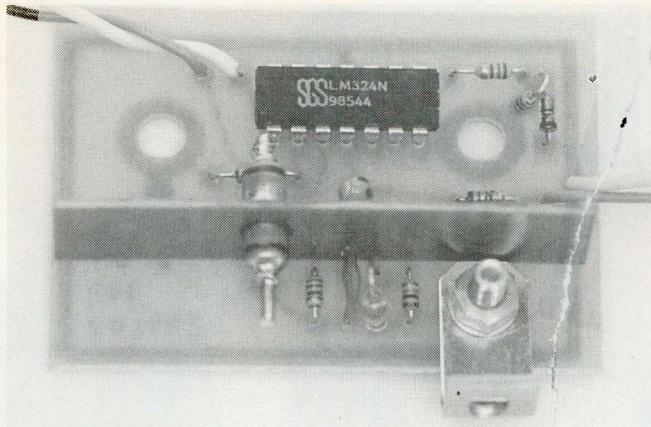

This is the completed printed-circuit assembly. The metal L-bracket at the lower right is the mounting for the telescopic antenna. It is secured to the board with a screw.

meter—the overall sensitivity is low, and the FSM is best used with relatively powerful RF sources.

Still, not having to tune the FSM is advantageous, so what's often done is to substitute an amplified meter, as shown in Fig. 2B, for the "barefoot" meter.

Notice that the Fig. 2B amplifier circuit is very similar to the one shown in Fig. 1B. The difference is R1. In Fig. 1B, it's part of the add-on amplifier. In Fig. 2B, the potentiometer is a part of the basic meter circuit.

Our Circuit

For most applications, the untuned but amplified FSM is the best choice because it has high gain, yet covers a broad range of frequencies without the need for plug-in or band-switched tuning coils. In fact, with a good amplifier design such as the one shown in Fig. 3, the FSM can almost sense that mythical flea's whisper—from 3 through 148 MHz no less—and yet, it is so immune to overload that, the meter pointer won't pin.

The key to the circuit is the amplifier, a type 324 quad op-amp, of which only one section is used. Why are we wasting three sections? Because, A) the 324 is cheap and easy to get; B) it's designed for a single-ended power supply (one, not two batteries); C) it will provide at least 20-dB DC gain; D) its output current is self-limiting—the pointer can't be pinned.

The photographs show an all-band FSM that uses the

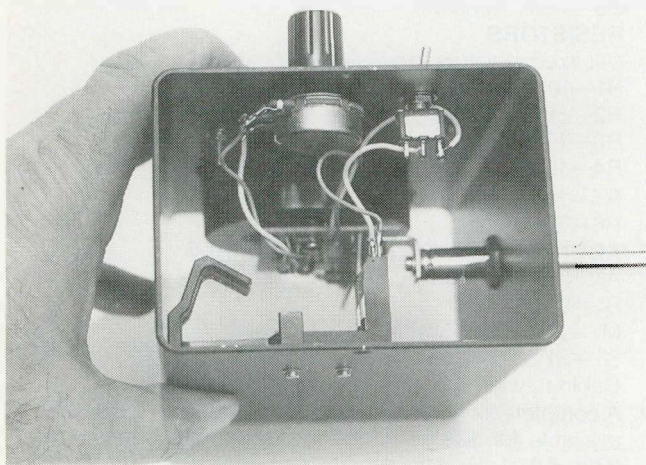

The printed-circuit assembly installs directly on the meter's terminal screws. The board is slightly narrower than the meter; it can slip through the meter opening in the cabinet.

circuit shown in Fig. 3. Other than using the specified integrated circuit (U1) and providing a small shield to separate the RF detector from the amplifier, just about anything goes in the way of parts and assembly. However, a large, sensitive meter, a metal cabinet, and a good-quality telescopic antenna will probably cost you more than the same project in kit form from Dick Smith Electronics, so we'll describe the assembly of Dick Smith's Model K-6321 Field Strength Meter. If you want to homebrew your own FSM simply use our circuit and photos as a guide. But you'll have to make your own printed-circuit board.

Construction

The kit comes completely knocked down; even the meter's scale and its mounting hardware are separate. The first step is to install the scale and put the meter aside; which sounds easier than it is because the clear faceplate doesn't snap off. (It's supposed to snap off, but ours didn't.) Very carefully, work a thin knife blade between the face and the meter's body dead center on the top edge. Rock the blade carefully—so you don't break the face. When you feel the face suddenly "give," it's loose. You can then remove the face, install the scale, and then snap the face back into position.

Next, assemble the printed-circuit board. It contains both the RF detector and the amplifier, and it mounts directly on the meter's terminals.

First, install a small shield across the length of the board, as shown. It's really a small strip of copper-clad board with a hole for feed-through capacitor C2. Small pins connect the copper foil of the shield through the top of the main board to the ground traces on the foil side. The feed-through capacitor must be soldered, as shown, to the shield. But if you're going to homebrew all the way and can't locate a feed-through capacitor, simply substitute an axial-lead ceramic type. Slip a short length of sleeving over one lead and pass that lead through the hole in the shield.

As shown in the photos, install the remaining board components, as well as a small metal L-bracket that will support the antenna. Connect the wires for sensitivity control R4 and for power switch S1 to the board, and then install the board on the meter's terminals. Make certain the board is installed so that the connections to the meter are the correct polarity. If the meter was supplied with a thin shorting wire across its terminals, be sure to remove the wire before installing the board.

Install the battery holder inside the cabinet, then slip the meter assembly into position. But before securing the meter, pass the antenna through a grommeted hole in the top of the cabinet and attach the bottom of the antenna to the L-bracket. Only when you have completely secured the antenna should the meter's mounting nuts be tightened. Then complete the remainder of the wiring to the panel-mounted components.

Meter Use

No adjustments are needed. Simply set power switch S1 to OFF, install the battery in its holder, and the meter is ready for you to use.

When you want to indicate the relative value of RF from an antenna, simply pull out the telescopic antenna, set S1 to ON, and advance R4 until you attain a convenient meter reading. Don't worry about a sudden increase in RF pinning the meter. Although the meter can read right up to the top of the scale, and perhaps even ease against the pointer's stop pin, it won't slam into the pin and damage the pointer, or knock the pointer's driving coil off its bearing. ■

SERIAL BUS SWITCH

for the Commodore-64

When you need to feed two computers to a single peripheral, flipping a switch is a lot easier than juggling cables.

By Mike Hinshaw

□ HAVE YOU EVER NEEDED TO USE YOUR PRINTER OR A serial disk drive on two computers instead of just one, and had to close down a program and turn off the computer to exchange the peripherals? If you have had this frustration, there is a solution. You can either spend up to \$100 and buy a commercially built two-circuit serial switch, or, for less than \$10, you can build your own.

As shown in Fig. 1, a *serial bus switch* for the Commodore-64 computer consists of three six-terminal DIN sockets and a six-pole, double-throw switch. (In actual fact however, a six-pole, double-throw switch consists of six individual two-position switches that are mechanically linked together.) The only "extra" components you'll need are a metal cabinet and a few extension cables for connecting to the sockets. While you can always purchase "factory-assembled" cables, you'll find it's much less expensive to make them up from about three feet of six-conductor cable and two six-terminal DIN connectors.

Can You Do Fine Soldering?

Before building the switcher you must know how to solder fine wires and small terminals, and know how to use an ohmmeter. If you don't know how to solder the confined terminals of a DIN connector, you'll need the help of a friend who does. Be careful when soldering because you can "blow" your computer with a bad connection.

Socket connections are best made using very fine wires, such as #28 or #30 (#30 is finer than #28). If the wires are too heavy they get in each other's way, and short-circuits may

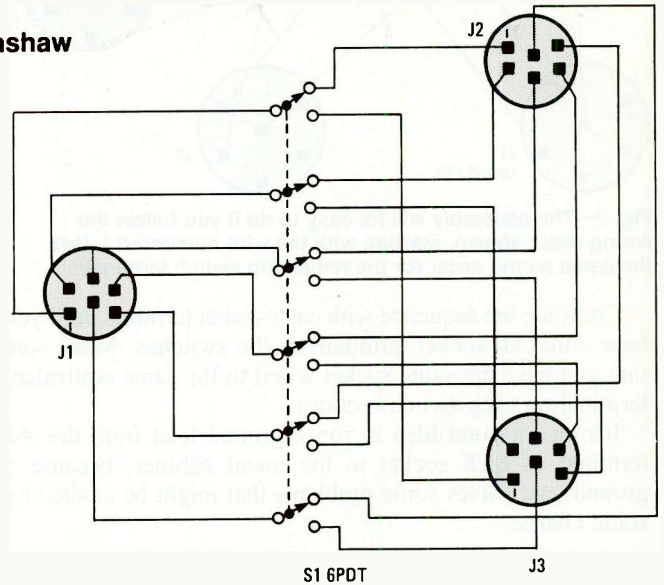

Fig. 1—Few parts are needed to make your own serial switcher. The 6PDT switch is actually three individual DPDT switches that are mechanically ganged together.

result. Also, fine wire is easier to thread into the switch terminals.

Make sure that you attach the wires to the correct switch terminals. To reduce the possibility of a wiring error, and to simplify troubleshooting if you do make an error, use color-coded wires if you can locate six different colors. Naturally, you should use *insulated* wires.

Since it's easy to make a mistake because all the sockets and switches look alike, a convenient numbered wiring order is shown in Fig. 2. To keep Fig. 2 from looking like a rat's nest, switch S1 is broken up into its three individual sections, labeled Sa, Sb, and Sc, and the wiring for only one side of the switch assembly is shown. Simply wire both sides the same way.

Keep in mind that you're working in close quarters, and things get tight. I found that the last two wires for each socket were a chore to connect due to the number of wires that were already in place. (Don't be surprised if the final product looks like a nest of worms.)

The best way that I found to minimize damage to previously-installed wires is to connect terminal 6 of J1 (the master socket) to the center terminal of the nearest switch section (Sa). Next, connect J2's center terminal to the right of the first switch connection. Finally, connect J3's center terminal to Sa's left switch terminal.

PARTS LIST FOR THE SERIAL SWITCH

J1, J2, J3—6-terminal DIN socket
 S1—6PDT push-on push-off switch
 Matching plugs, wire, solder, metal cabinet

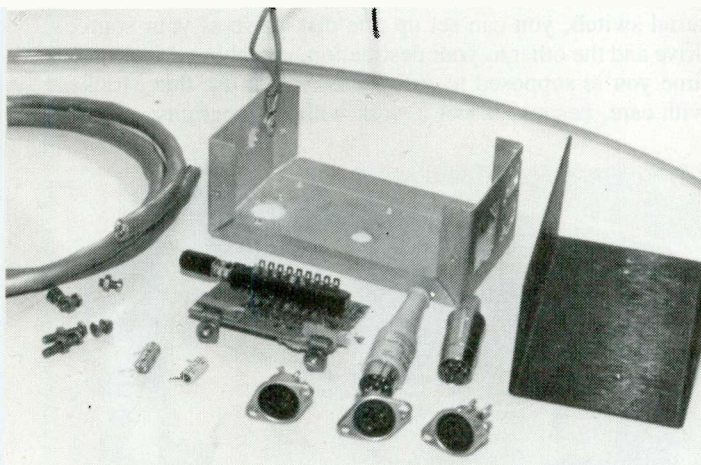

This is all that's needed to build the serial switchbox. The most expensive item is the cabinet, so try to salvage the box from an old project, as we have done here: the "extra" holes won't have any effect on the switching. Although the original design called for the two bypass capacitors shown, we determined they weren't needed, so they are not shown in the schematic. Do not try to "improve" things by installing bypass capacitors.

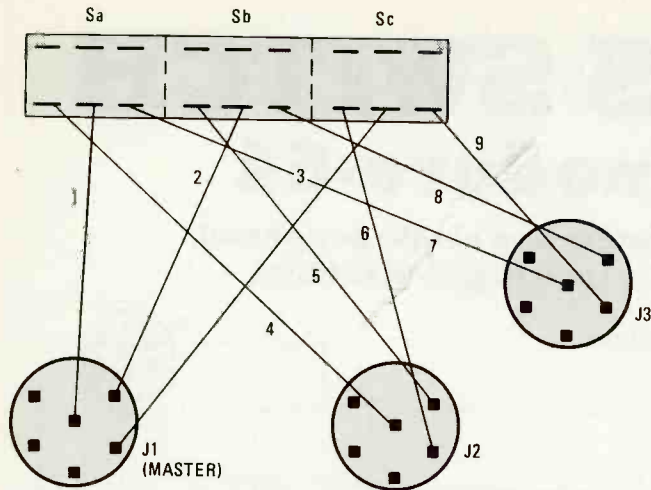

Fig. 2—The assembly will be easy to do if you follow the wiring order shown, starting with the wire numbered 1. Use the same wiring order for the remaining switch terminals.

Continue the sequence with each socket terminal until you have wired all socket terminals to the switches. Make sure that you have the same socket wired to the same equivalent terminal on each switch section.

It's also a good idea to run a ground lead from the #2 terminal of each socket to the metal cabinet, because a ground lead solves some problems that might be created by static charges.

Check the Connections

When the project is finished, check your solder joints for continuity with an ohmmeter and look for cold solder joints with a magnifying glass. Cold solder joints are usually dull, and often have rough surfaces. They are hard to find without actually testing your switch unless you inspect the joints with a magnifying glass. Defective joints often result in either bad data or weird error messages. When I wired my unit I had a couple of short-circuits and a number of cold-solder joints. Short-circuits can also *blow* your computer, and, at the very least, they will give you bad data.

As a final check of the connections, it's best to refer to Fig. 1 because it allows you to make sure that you have all your wires in the right places.

Make Your Own Cables

You need to build or buy at least one, and probably two, extra serial cables. The best way that I found to make a cable is to strip the wires in a six-lead cable and then put the boot for the connectors over the wires. Then connect all of the leads. Put the shielding back in place and slide the boot over the assembly. Check the cable with an ohmmeter, making sure that you have no short circuits, and that no connections are "open."

Checkout

The last step is to test your work in action. Using an extra cable, run a line from your peripheral to your switch, and then connect your computers to the two slave sockets (J1 and J2). Make certain that you have connected your peripheral to the common socket (the one that is not switched), so that a printer or disk drive is shared between two computers. You will need the extra cable or cables to interconnect the various devices. If you're going to use your switch regularly, keep the cables connected to the switch at all times so you won't wear

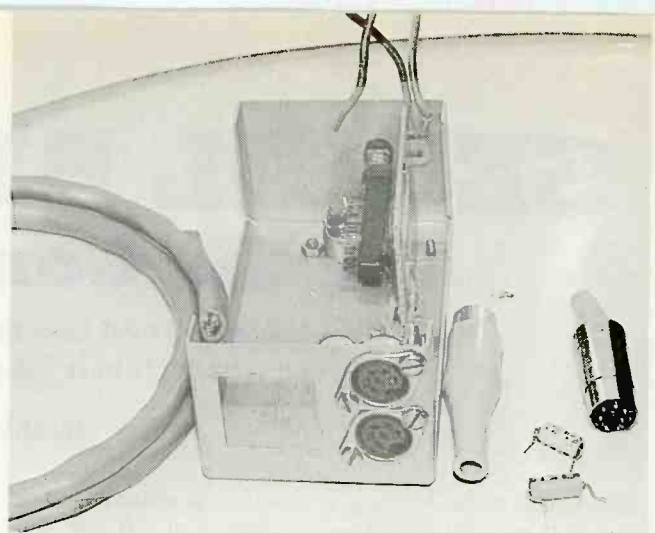

The almost-completed switcher. The two "free-floating" wires are grounds from the cabinet which will be connected to the ground terminals on sockets J1 and J2. Notice that the two capacitors have not been used.

out the sockets by constantly plugging and unplugging your system.

When you use the switch, brace it, either by holding it down or by mounting it on a solid object. You must activate the switch quickly and firmly, or you may reset one or both computers. There is a RESET line in the serial circuit, and if you take too long to operate the switch the RESET line will be grounded for long enough to reset your computer.

It's best to mount the switch to a solid object like your desk, and push the switch firmly and quickly each time you want to switch your computer. Never switch while any peripheral is in operation or you will reset the machines and lose all your data. If you practice, you will become proficient with the switch, and you should not have to reset your programs.

If you have two disk drives, the serial bus switch can also be used to make backup copies of your word processing data disks, just by resaving your data after you switch to your second disk drive. (This method will not work with any program that refers to the disk drive constantly, such as databases.) It is also possible to have two kinds of printers for different uses, such as dot-matrix and letter quality.

The serial bus switch also makes it easy to copy disks. Many good copy programs are set up for only one disk drive, and you really don't want to swap disks all the time. With the serial switch, you can set up one disk drive as your source drive and the other as your destination, switching drives each time you're supposed to switch disks. But use this "trick" with care, because it won't work with all programs. ■

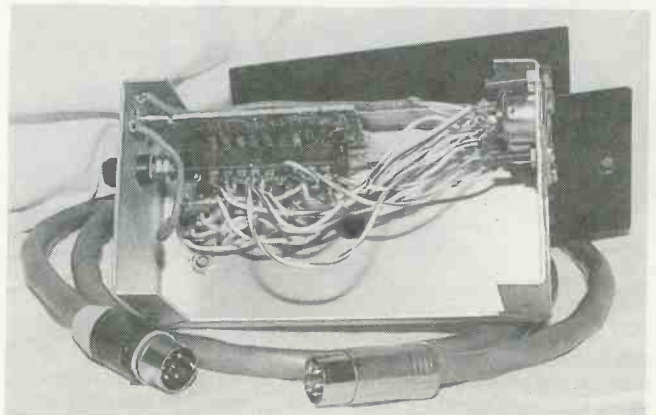

Finally, the completed switcher with its master input wire, which is made from a length of color-coded six-conductor cable.

●TORMENTOR●

Turn the tables on your persecutors and get sweet revenge as this simple circuit makes them climb the wall!

By Herb Friedman

□ NO MATTER HOW JUST OR RIGHTEOUS YOUR CAUSE MIGHT be, there are times when you just can't win! You can't even break even! An incompetent gets the raise or bonus you so justly deserved. You catch the blame for someone else's faults; or you get left out in the cold because someone is on the take. About the only satisfaction you can get at times like these is to even the score, and one of the most effective ways to even it up is with the *Tormentor*, a device certain to have your best, or worst enemy climbing the walls.

The *Tormentor* is a small, battery-powered, solid-state project that emits a brief *eeep!* every few minutes. Imagine sitting in a quiet room or car and every so often hearing an *eeep!* that seems to come from everywhere, but when you search, you can't find what caused the noise because it's gone. You go back to work, or sleep, or whatever, and "...eeep!

Think of the torment as 24 hours a day, day after day, your enemy is *eeeped!*

And if you want to really personalize the sound, you can change the output from an *eeep!* to a *foop!*, a *pfst!* or an *eeooooop!*

As shown in the photographs, the battery powered *Tormentor* is completely self-contained on a printed-circuit board. No power switch is needed or used because the intermittent sound results in a very low average current and the battery will last several months, possibly a year or more. If you want to silence the *Tormentor*, you simply unsnap the battery terminals until you're ready to get your revenge. Also, no cabinet is necessary because the entire project is contained on a printed-circuit board. If you want to use a cabinet, it can be put in any kind of enclosure, from a plastic box to a brown paper bag. The *eeep!*s will work their way through any kind of enclosure: plastic, metal or paper.

How It Works

Transistors pairs Q1/Q2 and Q3/Q4 form independent R-C oscillators. Refer to Fig. 1. The oscillation period of transistors Q1/Q2 is approximately one-half minute to several minutes. The time interval is determined primarily by R2 and C1. Transistors Q3/Q4's frequency, which is reproduced by the speaker (SPKR1), is determined primarily by R6 and C2, with a slight assist from R5. However, transistors Q3/Q4 cannot oscillate until Q3's base is forward biased. When power is first applied, the rush of current to charge capacitor C1 results in a voltage across the capacitor almost equal to the bias applied to Q1's base through resistor R1, and Q1 is cut off. Since there is no Q1 collector current, there is no voltage drop across R3. Since Q3's base and emitter are connected across R3, the potential at Q3's base is the same as at the emitter, so Q3 is also cut off and there is no oscillation, hence, no sound is heard from the speaker.



Meanwhile, C1 is discharging through R2, Q1's base-emitter and R3. See Fig. 1. Eventually, the voltage at Q1's base is determined by R1 so Q1 conducts, thereby causing Q2 to conduct. Q2's collector current causes a voltage drop across R3 which biases Q3 on, and Q3/Q4 oscillates, thereby producing a sound in the speaker.

However, at the instant Q2 conducts, the voltage drop across R3 causes C1 to charge through R1 and R2. In less than a second, the charge on C1's negative lead is almost equal, but opposite, to the bias through R1, so Q1 cuts off, disabling the Q3/Q4 oscillator. The result is a short burst of sound from the speaker at intervals of approximately 0.5 to several minutes depending on the values selected by the user for R2 and C1.

The sound quality emitted by the *tormentor* is determined primarily by R6, C2, and to a lesser extent by R5. Refer to Fig. 1. The values shown produce a *pfst!*. Decreasing the value of C2, or increasing the value of R2 (not more than $\times 2$) will raise the pitch and change the sound quality to *eeep!*. Increasing the value of C2 or decreasing the value of R6 will lower the frequency and change the sound quality to a *foop!*. Resistor R5 can be replaced by a jumper. As the resistance of R5 is increased the sound is generated with a slide: *eeep!* becomes and *eeooooop!*

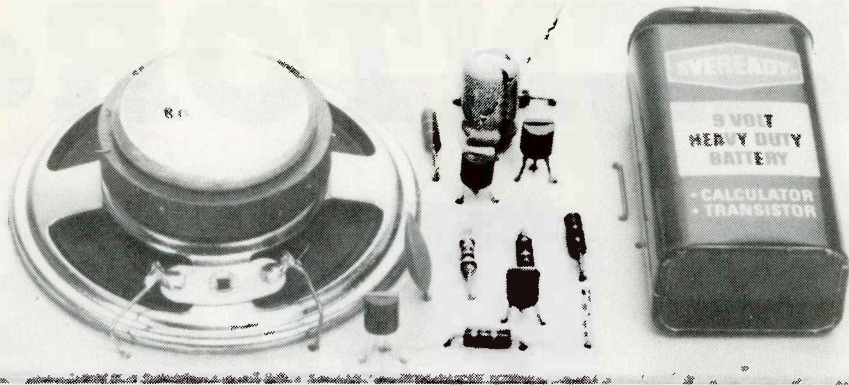

Here's the Tormentor completed and ready for application. The parts layout is not dense at all. Unsnap the battery terminal clip to power down the circuit.

A resistance of 270 ohms for R5 gives a nice lilt to an *eeep!*, while 1000 ohms produces an *eeeoop!*. For reliable operation, R5 should not be larger than 1000 ohms.

The values shown in the Parts List were selected for easy checkout and testing, providing an easily recognized sound every half minute. For maximum torment, we suggest lengthening the period between the burst of sound to two or more minutes by increasing C1's value to 100 or 200 μF —experiment to get the exact effect you want.

Construction.

The *Tormentor* is built on a $2\frac{3}{8}$ \times $4\frac{3}{4}$ -inch printed-circuit board, for which we provide a full-scale template. See Fig. 2. The component mounting holes are made with a #56, #57 or #58 drill bit. The two holes not connected to any foils are for a wire strap that secures the battery. Actually, the battery is secured by double-sided tape; the wire only helps the tape to keep the battery in position. Drill all the indicated holes first, then install all components except the battery and the speaker. Refer to Fig. 3.

The transistors aren't critical and just about any *silicon* general equivalents for the type specified in the Parts List can be used. Do not substitute germanium transistors for the silicon types. Their relatively high leakage current causes a continuous tone or unreliable sequencing. The optimum results are attained when Q1 and Q3 are complementary types for Q2 and Q4. But if you have any reasonable substitutes lying around, try them first; they will probably work okay.

The printed-circuit board's foil connections are for the EBC (emitter-base-collector) transistor lead arrangement (refer to the pin-out diagram in Fig. 1 and the parts-placement diagram in Fig. 3). If the transistors you use are ECB (emitter-collector-base) make certain you twist their leads so the base

PARTS LIST FOR TORMENTOR

SEMICONDUCTORS
 Q1, Q3—ECG-123A, NPN transistor (or equivalent)
 Q2, Q4—ECG-159, PNP transistor (or equivalent)

RESISTORS
 (All fixed resistors are 1/4-watt, 10% units)
 R1—1-Megohm
 R2—27,000-ohm
 R3—1800-ohm
 R4—100,000-ohm
 R5—Jumper (zero ohms) or 270-ohm (see text)
 R6—1000-ohm

ADDITIONAL PARTS AND MATERIALS
 B1—9-volt transistor-radio battery
 C1—30- μF , 10-WVDC, electrolytic capacitor (see text)
 C2—0.05- μF , 10-WVDC, disk or Mylar capacitor (see text)
 SPKR1—8-ohm, 2-inch PM speaker
 Misc.—Battery terminals, printed-circuit board materials, cement (see text), etc.

and emitter leads fit into the correct holes. Be careful not to introduce any shorts.

The printed-circuit template has been specifically drawn so the *flat* side of all transistors face the same direction. If the *flat* of one or more transistors face in a different direction, you have done something wrong.

Capacitor C1 is an electrolytic type so make certain that it is installed on the printed-circuit board with the correct polarity.

The value shown will provide a delay of approximately 0.5

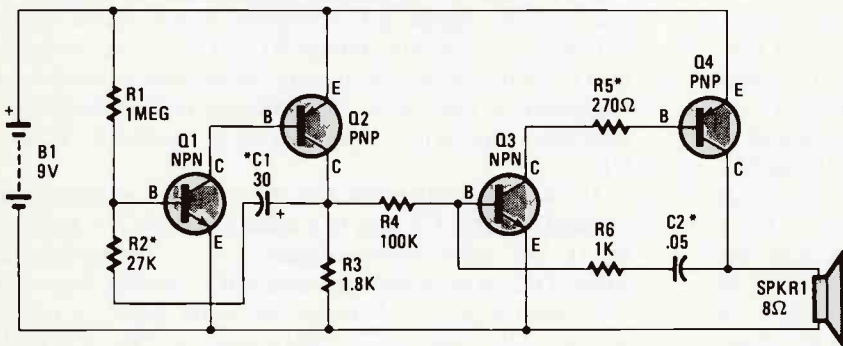

* = VALUES THAT DETERMINE ON-OFF TIME AND PITCH

NPN = ECG-123A
 PNP = ECG-159



BOTTOM VIEW

Fig. 1—The Tormentor consists of two simple oscillator circuits. It is simple enough to breadboard on a perfboard; however, you may be asked by friends to make several more. The printed-circuit layout may be duplicated inexpensively.

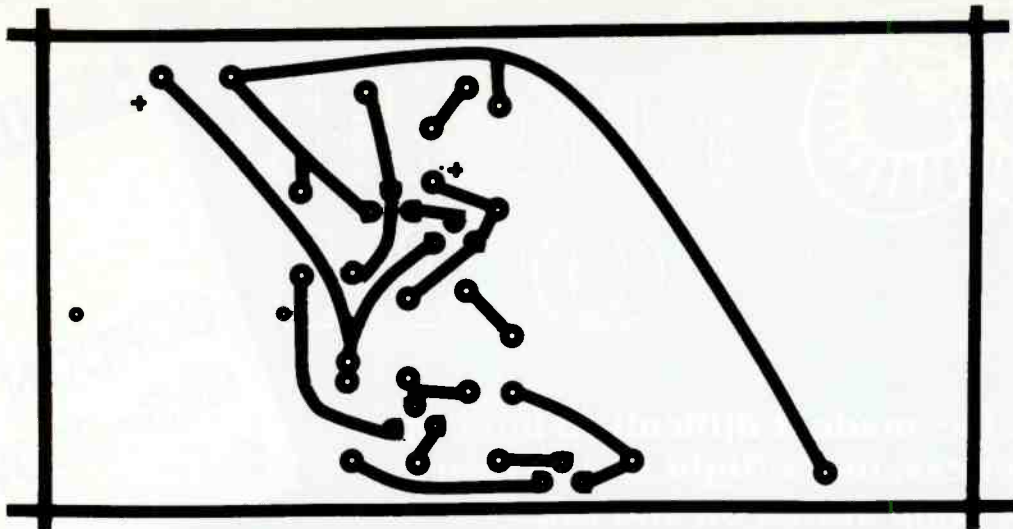

Fig. 2.—Same-size layout for the Tormentor's printed-circuit board. Should you decide not to mount the speaker on the PC board, you can then reduce the overall size of the layout.

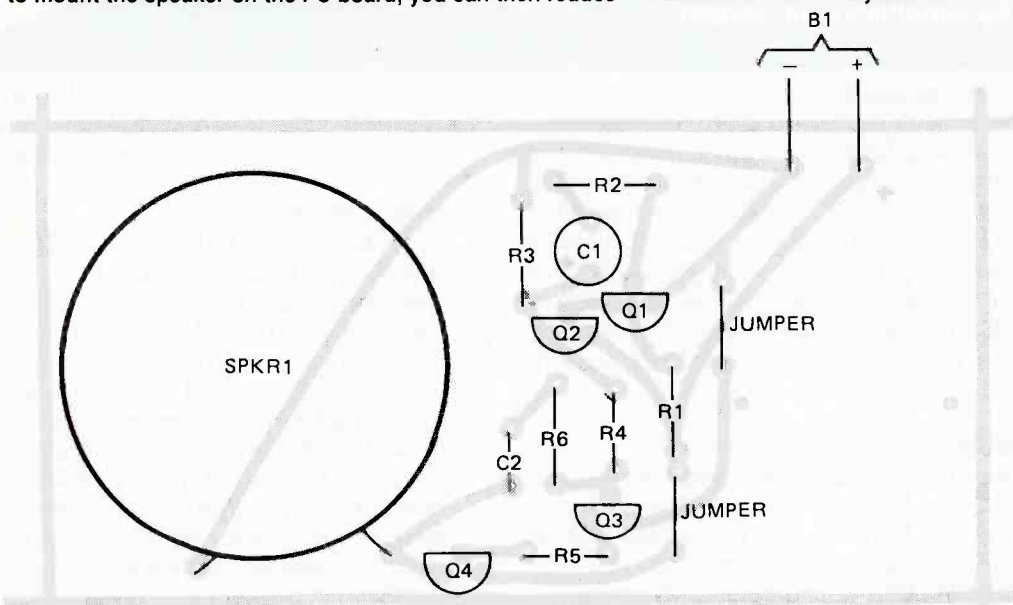

Fig. 3.—Shown here is the layout diagram of the Tormentor. The foil pattern is shown in an x-ray view.

minute between *eeep!*'s. Increase the value of C1 to increase the time between *eeep!*'s. 100 μF will provide a delay of almost 2 minutes; 200 μF will delay almost 4 minutes. To shorten the length of time the *eeep!* is heard decrease the value of R1, but try to go no lower than 500,000 ohms. If you think you'll be experimenting with different tone frequencies and time delays, leave a little extra length on the leads of the components indicated in the schematic diagram (Fig. 1) with an asterisk (*). Don't fold the parts' leads flat to the printed-circuit board when you solder them. That technique will permit you to remove them easily.

The speaker is the next to last component installed. The battery is last. The speaker is cemented face down on the component side of the printed-circuit board. If you use a good contact adhesive such as Barge (available from shoe repair shops) it will never come loose because Barge is what's used to glue soles and heels on shoes. Apply a thin bead of adhesive around the rim of the speaker, carefully position the speaker over the board, press it down, then remove the speaker and let the adhesive dry completely. Then very carefully position the speaker over the board directly in line with the adhesive ring and apply the speaker. You get only one

chance because the instant the speaker contacts the board it will be cemented and impossible to remove without damage, so get it right the first time.

Finally, place a strip or two of Scotch double-sided tape on one side of a 9-volt battery and press the battery to the board. If desired, you can back up the tape with a wire loop, passing the wire through the extra holes in the printed-circuit board.

Checkout

Start the *Tormentor* by installing the battery connecting clip on the battery terminals. The instant the battery terminals are applied, you should hear a tone that lasts for about a second or so. If C1 is very old the tone might last several seconds as the capacitor is reformed. If the tone continues and does not stop, check for proper installation of the transistors and C1. If the tone stops, simply wait for the next tone. It will seem like an eternity, but the tone should sound in about a half minute if you used the specified values. If several minutes go by and there is no tone, once again check the installation of the transistors, and C1 and C2.

If the *Tormentor* sounds off every few minutes, it's ready for use. Now whom do you dislike the most? ■



NIGHT OWL



When fate has made it difficult to light up the darkness, use a Night Owl to turn the lamp switch on and off.

By Jonathan Alan Gordon

THIS DEVICE IS LIKE HAVING YOUR OWN PERSONAL GENIE. It enables you to select any of five different transducers to operate a lamp. Now think a moment—Are you certain that there isn't a place in your own home for this "solution looking for problems?" Simply connect the Night Owl between the powerline and a lamp; place the Night Owl's remote-control switch on a table, a desk, by your bedside, or any other place that's easy to reach with your hand or foot, and simply touch it to turn the lamp on and off. And if you can't reach out, we'll show you how to control the lamp with a short breath of air.

Remote Controls

Figure 1 shows five kinds of remote-control devices that can be used with the Night Owl: The pedal switch, hand switch, cord switch, tape switch, and puff switch. All are basically normally open devices that close when activated. On closure, the Night Owl provides power to the lamp.

Safety First

Within the Night Owl is a transformer-isolated power supply that delivers the 10-VDC operating voltage for K1, the intermediate load-switching relay (see Fig. 1). In that way the user is safely isolated from both the AC line voltage and the relay's switching contacts.

The fact that no batteries are required is another *plus*,

guaranteeing you that once the Night Owl is plugged into the electrical outlet it will neither grow weak nor intermittent over time, nor need battery replacements.

How It Works

As shown in Fig. 1, the circuit is fairly straightforward. The power supply is comprised of a 117 to 12.6 volt, center-tapped transformer and a full-wave bridge rectifier using a capacitive filter. A regulated supply isn't used because the entire circuit draws no more than 20 mA, and the individual circuit components are very tolerant of voltage variations. When the full 20 mA of load current is drawn, the power supply's output is about 10 volts; while under no-load conditions the output rises only to about 12 volts. Considering that the CD4013 dual D flip-flop is CMOS and can work from 5 to 15 VDC, and that the 12 volt relay works fine from 8.4 to 12 volts, there's no need for regulation.

When remote switch S1 is depressed, V_{CC} (10 VDC) is applied to pin-3, U2's clock input. U2 is configured as a toggle flip-flop where the Q output, pin-1, changes state and latches on the rising edge of each clocking pulse. The complementary \bar{Q} output, pin-2, is fed back through a resistor (R2) and capacitor (C2) delay loop to the D(ata) input, pin-5, which effectively debounces the remote switch. The Q output is used in turn to switch relay-driver transistor Q1 on and off. When Q1 is *on*, relay K1 is energized and its SPST contacts apply power via SO1 to the associated lamp.

The Night Owl's relay is U.L.-rated at 125 VAC, 350-watts tungsten (meaning: standard incandescent lamps). Relays typically have four U.L. contact ratings: VA (volt-amperes), DC watts, inductive watts, and tungsten watts (for incandescent lamps).

Relay specifications in most general catalogs leave much to be desired. For example, Radio Shack's 275-247 SPST miniature relay has a listed contact rating of 3 A at 125 VAC, or 375 VA—a rating that tells you very little if you want to know how many 60-watt incandescent lamps the relay's contacts can safely handle. In fact, you'd have to guess the tungsten-watt rating.

Cabinet-mounting connectors allow the *Night Owl* to be plugged directly into the powerline, and the lamp directly into the *Night Owl*. The small jack at the base is for the remote control switch or control device.

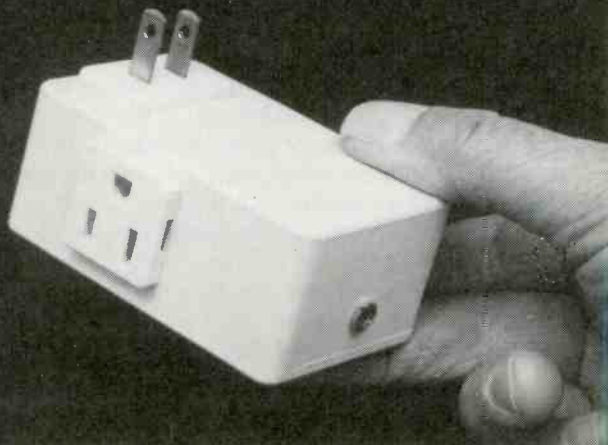

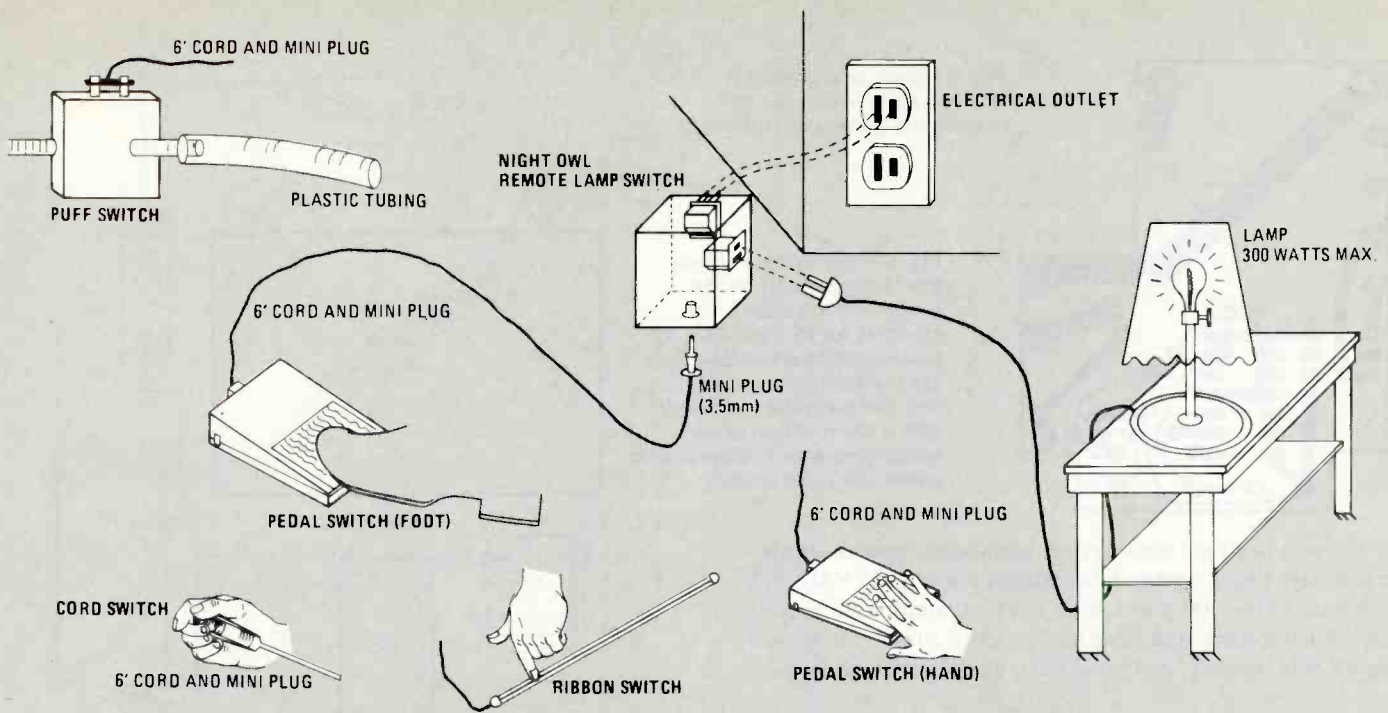

Fig. 1—Connect the *Night Owl* between the powerline and a lamp, and just about any type of switch can be used for a remote control.

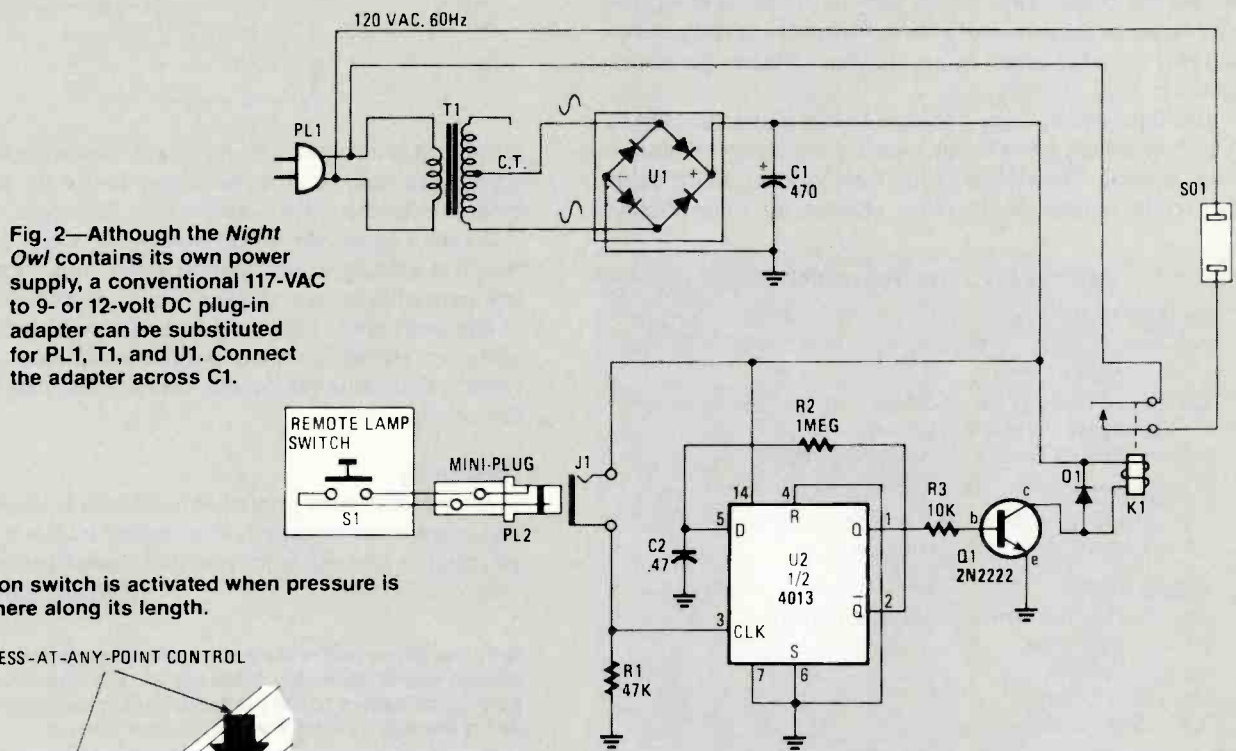

Fig. 2—Although the *Night Owl* contains its own power supply, a conventional 117-VAC to 9- or 12-volt DC plug-in adapter can be substituted for PL1, T1, and U1. Connect the adapter across C1.

Fig. 3—A ribbon switch is activated when pressure is applied anywhere along its length.

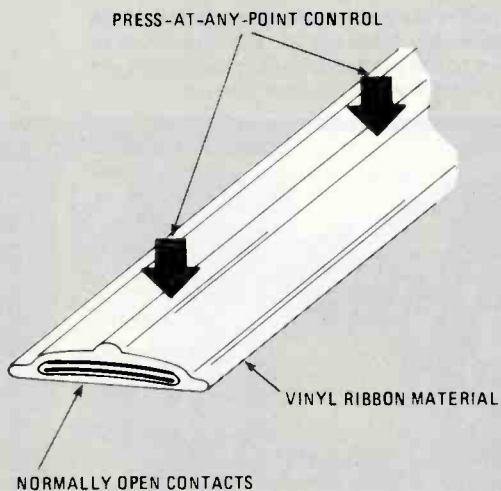
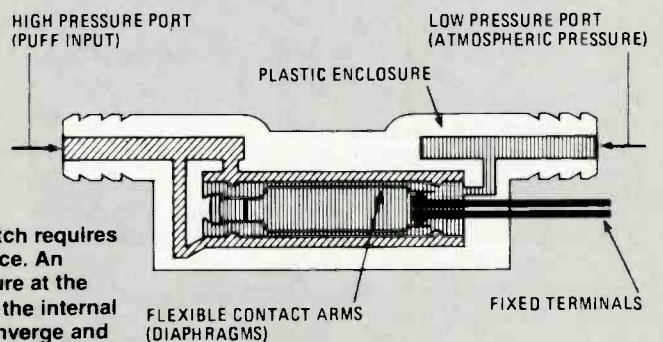

Fig. 4—A puff switch requires no mechanical force. An increase of pressure at the input port causes the internal diaphragms to converge and close the switch's contacts.



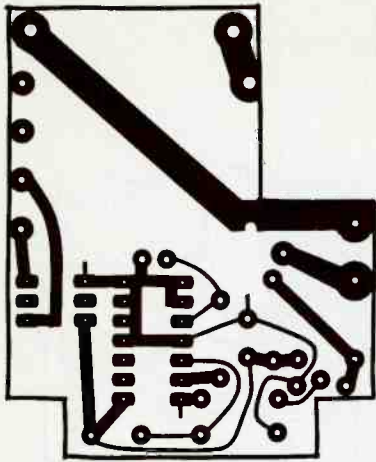

Fig. 5—Trace or photocopy this full-scale template when making the printed-circuit board.

Fig. 6—This is the stuffing (parts placement) on the printed-circuit board. The symbols for PL1 and SO1 are unconventional because they are chassis-mounted devices. You can substitute for them with a short length of wire terminated with a conventional power plug and socket.

Without any hard engineering data sheets, common experience says to use a relay with contacts rated at 125 VAC, 3-5 A for one or two 100-watt lamps, but 15 A contacts are needed for inductive loads and other heavy-inrush current loads such as TV sets, motors, electrical fans, and some computers.

Remote Lamp Switches

Figure 1 shows several of the switches that can be used to control the Night Owl. Some, such as the pedal (foot) and cord switches are commonly used. Others, such as the ribbon and puff switches might be new to you, so their operation is shown in Figs. 3 and 4.

The Tapeswitch, Corp.'s *Ribbon Switch* is shown in Fig. 3. A ribbon switch provides momentary contact press-at-any-point control. The ribbon is light-green vinyl and requires only eight ounces of finger-tip pressure to cause contact

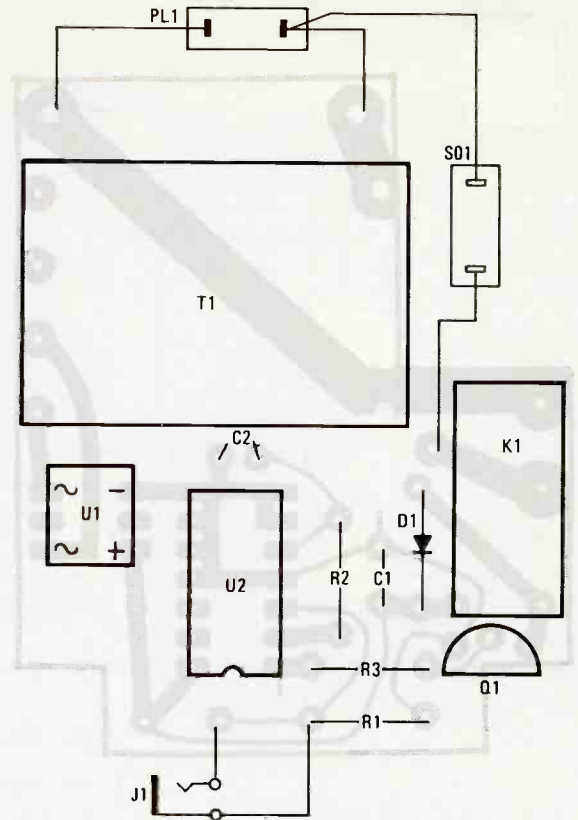

closure. It can be mounted for finger-tip control on a table or against the wall, or it can be positioned on the floor. In any case, use double-sided adhesive tape for secure attachment.

Figure 4 shows the World Magnetics, Corp. *Puff Switch*, which is actually a combination *differential pressure sensor* and momentary-contact switch. Only a light puff of air, such as one uses to blow bubbles in a glass of soda through a straw, will exert enough pressure to move the internal diaphragms inward, deflecting the flexible contacts and thus completing the circuit.

Assembly

A template for the printed-circuit board is shown in Fig. 5. The component mounting—the *stuffing* is shown in Fig. 6. If you want to save either construction time or component cost,

(Continued on page 162)

Only the power and remote connectors aren't part of the printed-circuit assembly. Make certain the wires from the power connectors to the printed-circuit connections are heavy enough to carry the lamp's rated current.

PARTS LIST FOR THE NIGHT OWL

SEMICONDUCTORS

- D1—Silicon diode, 200V-PIV, 1-A
- LED1—Light-emitting diode
- Q1—2N2222, NPN transistor
- U1—Bridge rectifier, 200-PIV, 1-A
- U2—4013 dual D flip-flop integrated circuit

CAPACITORS

- C1—470 μ F, 25-WVDC, electrolytic
- C2—0.47 μ F, 35-WVDC, tantalum

RESISTORS

- (All resistors are 1/4-watt, 10%, fixed units)
- R1—47,000-ohms
- R2—1-Megohm
- R3—10,000-ohms
- R4—1500-ohms

ADDITIONAL PARTS AND MATERIALS

- J1—2-conductor miniature phone jack
 - J2—3-conductor DIN socket
 - K1—SPST relay, 12-VDC; 125-VAC, 1-A contacts (see text)
 - PL1—Electrical snap-in plug
 - PL2—3-conductor DIN plug
 - S1—Remote switch, SPST, see text
 - SO1—Linecord snap-in socket.
 - T1—Transformer: AC-line, step-down, power; 12.6-volt, 180-mA center-tapped secondary winding, (Signal Transformer ST-2-12, or equivalent)
- Printed-circuit materials, solder, wire, plastic enclosure, tape, RTV silicon rubber.

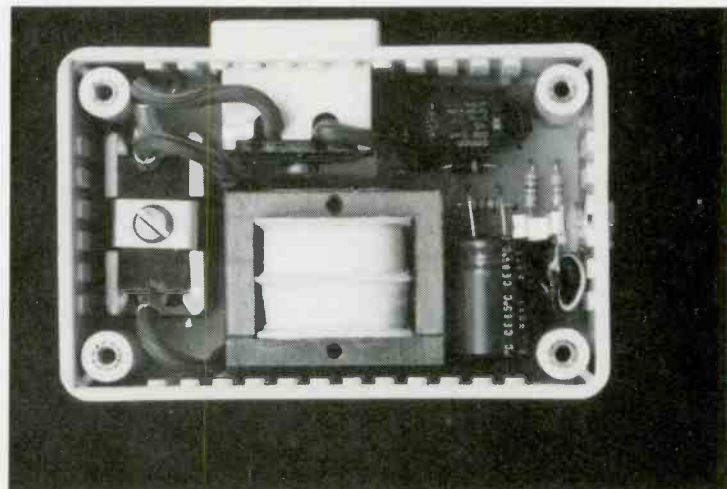



ECONOMY NiCd BATTERY CHARGER

**Here's a convenient and safe way to charge
both trickle and fast-charge NiCd batteries**

By Ladislav and Peter Hala

□ALTHOUGH THE TAPE AND RADIO WALKMAN, THE POCKET-TV, and battery-powered toys are becoming ever more popular, there is no getting around the fact that they are incredible energy consumers, and the cost of their upkeep skyrockets when you have to keep feeding them energy using common carbon-zinc or alkaline batteries. Also, the operating cost is especially high when you forget to switch them off before you fall asleep. But all these worries can be eliminated by substituting NiCd (nickel-cadmium) batteries for ordinary zinc and alkaline types.

Although the cost of NiCd's is some two to three times greater than that of the alkalines, they can be recharged up to 1000 times, thus saving you pocket-money. However, there is an additional cost one has to take into account: that of a battery charger.

Although there are a considerable number of commercially-available chargers in the marketplace, most are simply "trickle-chargers;" they charge the batteries at a very low rate

of current for a very long period of time. Few, if any, have a battery-test or condition indicator, none have an adjustable rate of charge, and none of the generally-available, low-cost chargers will fast-charge one of the new breed of fast-charge NiCd cells. (While you can always trickle-charge a NiCd designed for a much higher charging rate, the reverse isn't true. Normally, you cannot safely recharge a NiCd designed for trickle-charging.)

But for less than \$10 if you're a good shopper—less than \$20 if you're a poor shopper—you can build the Economy NiCd Charger, which has several *pro* features not found on the usual charger you're likely to find at your local electronic or auto-aid stores.

Special Features

The most-interesting feature of the Economy NiCd Charger is visual indication of: A) normal operation (green LED); B) standby or open battery circuit (orange LED); C)

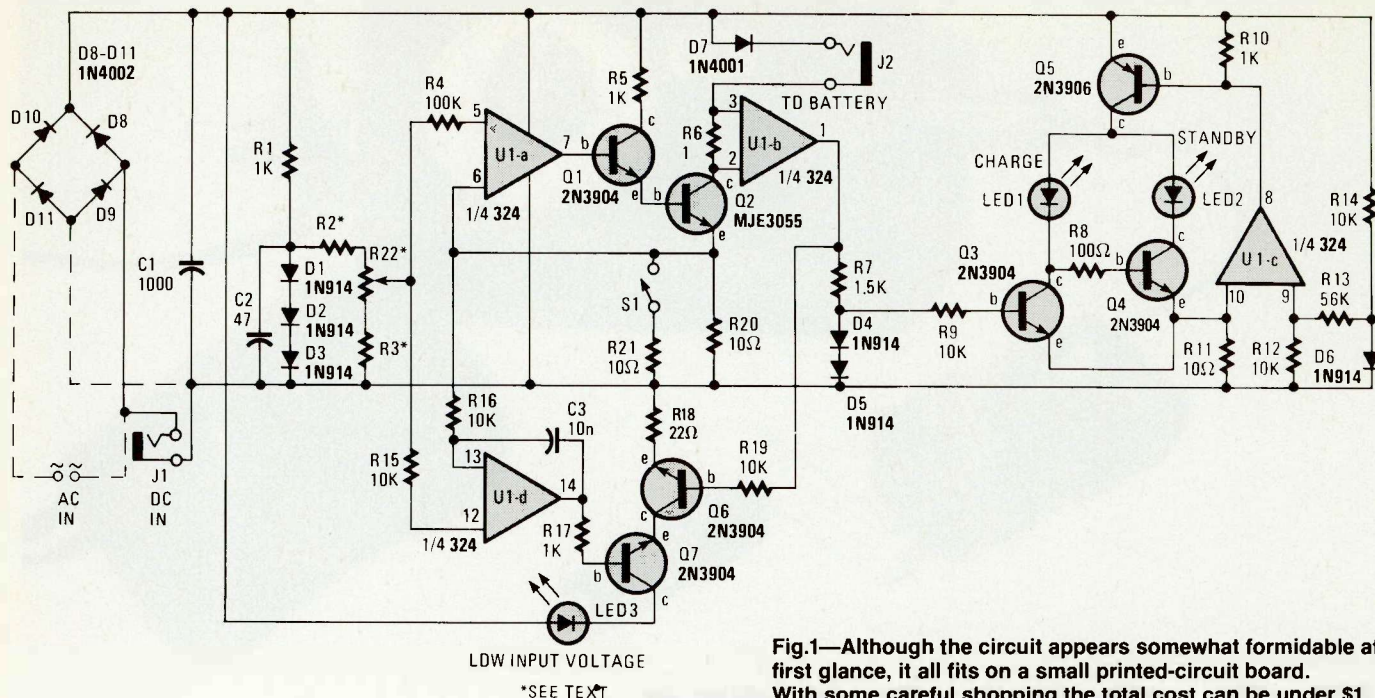

Fig.1—Although the circuit appears somewhat formidable at first glance, it all fits on a small printed-circuit board. With some careful shopping the total cost can be under \$1.

low input voltage (red LED).

Unlike many home-brew NiCd charger circuits that don't feature the ability to select various charge currents, the Economy NiCd Charger can adjust its charging current continuously in two ranges: either from about 2-mA to 150-mA, or from 4-mA to 300-mA. Another feature that most chargers lack is some kind of indication of whether or not there is an open circuit between the batteries and the charger—perhaps due to a poor connection. The Economy NiCd Charger indicates that the battery is connected or disconnected.

Another big plus for the economy charger is the power efficiency of power transistor Q2) and the power supply's transformer. Good efficiency has been achieved by using a commercial AC to DC adapter switchable from 3V to 12V, and by using a low-voltage detection circuit.

A special note about the power supply is in order. The normal power source is what is called a plug-in or *wall adapter*, which consists of a small plastic case that plugs into an electric outlet. The case contains a power transformer, a rectifier, and usually some amount of capacitive filtering. Its output is a low value of DC—usually between 3 and 12 volts, or switch-selectable within that range—and the DC output connects to J1, the charger's power socket.

Since transformer-adapters are available at rock-bottom prices on the surplus market, we have also made provision for their use. The transformer-adapters consist only of a low-voltage transformer in a plastic case that plugs into an electric outlet. Since the transformer-adapter's output is AC, the rectifier and filtering must be provided within the charger. That is done through the optional components D9, D10, D11, and C1. The transformer's secondary connects to the terminals indicated in Fig. 1 by the two small sinewaves and marked "AC IN."

About the Circuit

The heart of the charger is U1, an LM324 quad op-amp. It is a relatively inexpensive integrated circuit whose inputs can be swung down to, and below, the ground, thus allowing us to

compare voltages at ground potential.

Diodes D1 through D3 comprise a simple Zener diode of about 2.2V. Although the voltage varies only slightly with the input voltage, the variations are insignificant for the desired voltage stability. Since you can buy a package of fifty 1N914 diodes for under \$3, the choice of using 3 diodes is cheaper than using a 2.2V Zener diode. Besides, you will need more 1N914 diodes, so buying in bulk will save you some money.

Variable resistor R22 can be any value between 10,000 and 50,000 ohms. Consequently, you will have to calculate the values for R2 and R3 to give you a regulation range from about 0.02V to 1.5V. For example:

$$R2 = (E_D - E_{MAX}) \div (E_{MAX} \div R22)$$

where E_D is the voltage drop across D1–D3, and E_{MAX} is the maximum voltage setting of R22. R2 and R3 are determined by:

$$R2 \text{ (in ohms)} = \frac{1}{5}R22,$$

$$R3 \text{ (in ohms)} = V_{R3} \text{ (at the 0.02V level)} \div (R_{MAX} \div R22),$$

$$R3 \text{ (in ohms)} = \frac{1}{5}R22$$

(for a 10,000-ohm variable resistor this works out to be about 4700 ohms for R2 and 150 ohms for R3). The reason we use R3 is that at low charge currents the voltage drop across R6 is so small that it cannot be detected by U1b. Although the battery is charged with that low a current, the charging/no-charging detection circuit indicates open circuit. We improve the detectability simply by raising the value of R6, but by doing so the efficiency of the circuit decreases; therefore a compromise must be reached.

U1a, Q1, Q2, and associated resistors comprise a simple current source. The voltage drop detected across R20 (and R21 when S1 is closed) is compared to the preset voltage of R22. If the voltage on R20 is lower, U1a pushes the output towards the positive side; thus, Q1 and Q2 open more until sufficient current causes a preset voltage drop. Resistor R5 is needed to limit the base current through Q2 in case the batteries aren't connected. The quiescent base current is sufficiently small so as not to cause

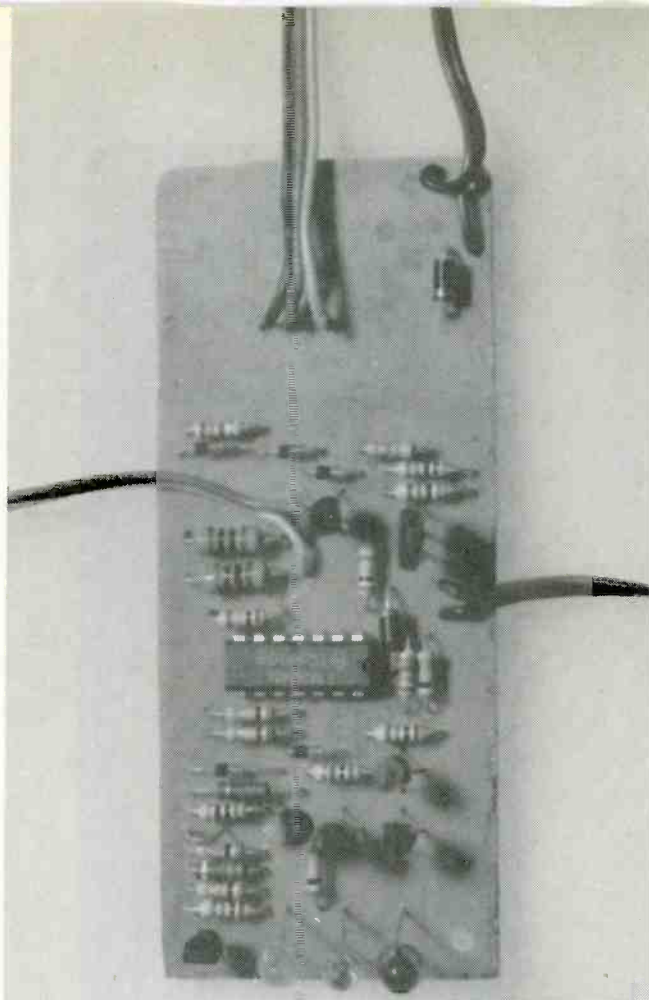

The printed-circuit board layout is clean and open. Small sections of ribbon cable have been used to connect the external hardware such as the input and output jacks, etc.

any harm to the transistor, but it's large enough to assure good regulation. Diode D7 protects the battery(s) against discharging if the circuit is switched off while the batteries are connected.

Detection

The charging/no-charging detection circuit is comprised of U1b, Q3, Q4, LED1, LED2, D4, D5, and their associated resistors. When no battery(s) are connected there is no voltage drop across R6 and the output voltage from U1b is zero; Q3 is thus turned off and Q4 is turned on through LED1 and Q6, thereby causing the *standby* LED (yellow) to illuminate. When the batteries become connected, a small voltage drop develops across R6. The output voltage of U1b then swings to almost $V+$ —which is then trimmed down to about 0.4 volt by D4 and D5—and is fed through R8 to Q3, causing Q3 to open and Q4 to close. Now the green *charge* LED illuminates, while the *standby* LED is switched off.

The current entering Q3 is relatively constant due to a constant voltage across D4 and D5. The constant current is especially important when we want to use a variable input voltage. If we did not have any control of Q3's base current the brightness of LED1, and therefore LED2, would change with the changing input voltage, giving us confusing results. To assure constant brightness over a large supply input-voltage range, we implemented a constant current source for the LED's comprised of U1d, Q5, D6, and their associated resistors. The circuit is very similar to the constant-current source used for charging, but here we control a PNP transistor. Since a LM324 op-amp doesn't swing its output to $V+$ completely, R10 is required to pull up the output of U1d so that Q5 can be closed.

Error Detection

The error circuit consists of U1c, Q6, Q7, and LED3. Whenever the preset value of R22 is larger than the maximum delivered current a voltage drop develops across U1c (and U1a as well). Then, a positive voltage of less than $V+$ appears at the output of U1c, which in turn opens Q7. But LED3 will illuminate only if both Q6 and Q7 are open, and Q6 will be open only when the battery(s) is in the circuit. To explain why we have to use such a complicated circuit we have to return back to the constant-current charging circuit. We mentioned that U1a opens Q1 and Q2 as much as possible whenever the the drop voltage across R20 is insufficient. That can occur in two cases: when batteries are disconnected or connected.

The first case can occur when R22 is set at a higher level than can flow through R5. Since we want to indicate low, insufficient input voltage only for the second case, Q6 must be used in the circuit.

Finally, D8 protects the whole circuit against any accidental reverse supply voltage. The diode can be left out if you use an adapter without a reverse-polarity switch. Since the diode voltage drop is between 0.7V and 1V, we are actually using 10.5 volts - 10 volts from the 12 volt input (in case diodes D7 and D8 are connected in the circuit). Therefore, if you do not worry about any damage, it would be much better to omit D8.

Now let's build the charger.

Construction

Assembly is simple and it should not take more than a long evening. All components except potentiometer R22, switch S1, and J1 and J2 are installed on a printed-circuit board, for which we provide the full-scale template shown in Fig. 2. Install the components in this order: First the resistors, then the capacitors.

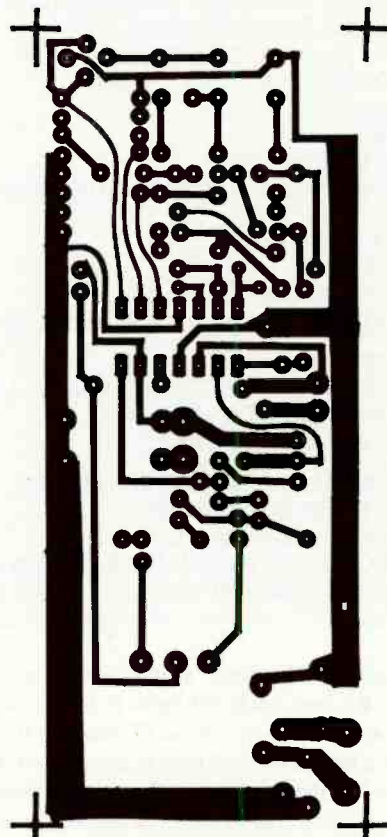

Fig. 2—This is a full-scale template for the printed-circuit board. There are a few extra holes, which are actually pre-made connections for the optional AC power source.

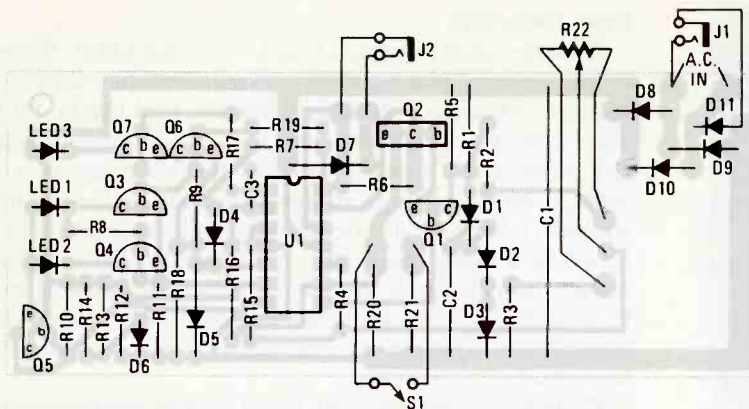

Fig. 3—When stuffing the parts on the printed circuit board, double-check that integrated-circuit U1 is positioned correctly, and that each diode is installed with the correct polarity.

PARTS LIST FOR THE ECONOMY NiCd BATTERY CHARGER

Semiconductors

- D1, D2, D3, D4, D5, D6—1N914 small-signal diode
- D7—1N4001 or 1N4002 silicon rectifier diode
- D8, D9, D10, D11—1N4002 silicon rectifier diode
- LED1—Light-emitting diode, orange or yellow
- LED2—Light-emitting diode, green
- LED3—Light-emitting diode, red
- Q1, Q3, Q4, Q6, Q7—2N3904 transistor
- Q2—MJE3055 transistor
- Q5—2N3906 transistor
- U1—LM324 op-amp integrated circuit

RESISTORS

(All resistors 1/4-watt, 10% unless otherwise stated.)

- R1, R5, R10, R17—1000-ohm
- R2, R3—10,000- to 50,000-ohm, see text
- R4—100,000-ohm
- R6—1-ohm
- R7—1500-ohm
- R8—100-ohm
- R9, R12, R14, R15, R16, R19—10,000-ohm
- R11—10-ohm
- R13—56,000-ohm
- R18—22-ohm
- R20, R21—10-ohm, 1/2-watt, 1%
- R22—10,000- to 50,000-ohm linear potentiometer

CAPACITORS

- C1—1000- μ F, 16-WVDC, electrolytic
- C2—47- μ F, 10-WVDC electrolytic
- C3—10-nF (.01- μ F), ceramic

ADDITIONAL PARTS AND MATERIALS

- J1, J2—Miniature phone jack
- S1—SPST miniature toggle switch
- AC to DC adapter, switchable 3 to 12-volts, plastic cabinet, printed-circuit materials, wire, solder, etc.

(If you are using a DC adapter as the power source, you can omit C1 and C2. We have included them in the circuit diagram and have made space for them on the PC board.) If you use an AC transformer-adapter, you will have to install diodes D9, D10, and D11 along with filter capacitors C1 and C3. Capacitor C3 was intended to protect U1d against oscillations, but the capacitor proved to be unnecessary.

Next, install the diodes and the LED's. Leave the LED's leads about 1-in. long so that you can place a potentiometer above the

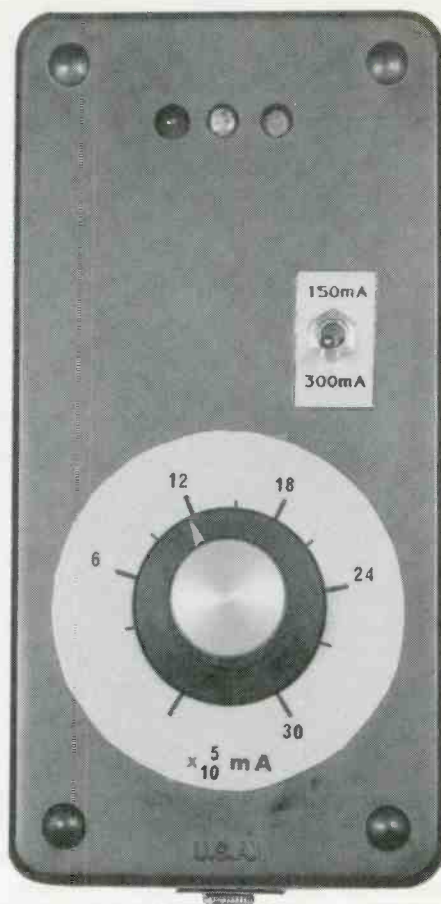

To prevent damage caused by overcharging, both the charge rate switch (S1) and the charge rate control (R22) should be clearly labeled and calibrated. You can use the supplied template for R22 if you don't need or want more precise values. However, check the overall calibration with a dummy load and a meter.

circuitry. Finally, install the transistors and the integrated circuit.

Pay particular attention to the orientation of the semiconductors and capacitors. Although the printed-circuit board was designed for transistors in a TO-92 case, we have provided additional traces and pads for those transistors whose lead configuration is similar to that of the TO-18; this way you won't have to cross their base lead under the case.

Finally, connect J1, J2, R22, and S1.

Check the connections carefully after all components are installed. Before applying power, make sure that switch S1 is in the 150-mA position, that potentiometer R22 is set for its minimum value, and that no battery is connected to the output. Then apply about 4.5-VDC to J1. The orange LED should be lit, indicating the *standby* (power on) state. Connect a 100 ohm, 10-watt resistor in series with an ammeter to output jack J2. That should cause the green LED to illuminate, indicating *charging*, while the orange LED should be turned off. If this doesn't happen, try increasing R22's value. If the LED's switch states then the value of R3 or R6 is too small and should be increased. If turning the potentiometer doesn't help, look for an open circuit or a bad component. If a red LED turns on after you connect the resistor and ammeter, then you have to check the value of R4. By turning the potentiometer towards the maximum value you should observe an increase in the current through the resistor until no further increase is possible. At this point the red LED should be on, indicating a low input voltage for the desired charging current.

TABLE 1—LED INDICATORS

Green LED1	Orange LED2	Red LED3	Operation	Troubleshooting
●	○	○	Normal operation- -Charging	
○	○	○	Standby (power on) in case batteries are not connected	Connect batteries.
○	●	○	No Charging in case batteries are connected —open circuit; -input voltage is lower than the battery voltage.	Look for an open circuit between the charger and batteries. Increase the input voltage.
●	○	●	Charging, but the input voltage is inadequate for the desired current.	Increase the input voltage or decrease the charge current.
●	●	●	Voltage across the output leads is the same as the battery voltage.	Increase the input voltage.

○ Indicates LED off ● Indicates LED on

By increasing the input voltage the red LED should be turned off. All possible LED combinations are listed in Table 1. One curious situation occurs when all LED's are lit. In this instance the battery has the same voltage as the maximum voltage that can be found across the output leads, so the circuit cycles between charging and non-charging states, causing the LED's to switch back and forth.

Calibrating the current scale is easy and it can be done in two ways: 1) According to the ammeter connected in series with the battery(s); 2) According to the voltage readings across R20.

To help you get the calibrations inside the ballpark, a full-size calibration template for R22 is provided in Fig. 4. Either trace the template or make a photocopy.

Applications

As mentioned earlier, you can charge your batteries at a constant current of about 2 mA to 300 mA. The range can be extended beyond 300 mA by decreasing the value of R21 (and R21), and by assuring that the power supply or power transformer and transistor Q2 can handle the maximum current. Higher charge current might also make it necessary to fit Q2 with a heatsink. Also, if you do not need to go down to 2 mA and do not need sensitive adjustment of the current up to 150 mA, you can eliminate switch S1 and connect resistors R20 and R21 with a jumper.

Consult the battery manufacturers' data or *spec* sheet when recharging any NiCd battery. If data isn't provided or available, you'll most likely find the recommended charging rate is printed directly on the battery.

Table 2 provides acceptable charging guidelines for commonly-available NiCd cells; the kind you'll find at Radio Shack and at mail-order electronic parts distributors. As a rule of thumb, the charge current should be about one tenth of the total current capacity applied for about 12 to 14 hours. That value is often described as *the 14 hour charging rate*; it is usually printed directly on the battery. For example, the battery's label might be imprinted "Charge rate is 40 mA for 14 hours."

For rapid or fast-charging, you can use up to one quarter of the total charge current for about 5 to 6 hrs. However, it is not recommended that batteries intended for a 12 to 14 hour *trickle-*

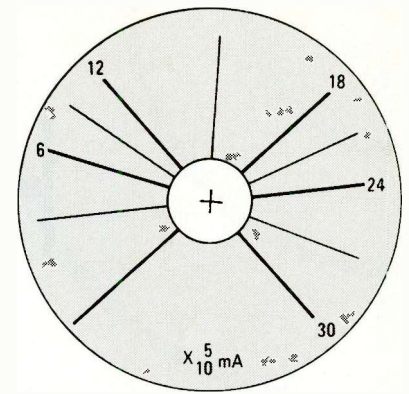

Fig. 4—Although you should determine your own calibration for various charging currents, this scale will put you well inside the ballpark if you use a linear potentiometer for resistor R22.

**TABLE 2
TYPICAL NiCd SLOW AND FAST CHARGING CURRENT**

Size	Volts	Current Capacity (Amp Hour)	Normal charge	Fast charge
AAA	1.25	0.150	15	40
AA	1.25	0.45	45	115
C	1.25	1.10	110	275
D	1.25	1.10	110	275
9-volt	7.2	0.065	6.5	17

charge be fast-charged because it's possible for the internal pressure to exceed allowable limits and blow the safety vent. A NiCd with an open safety vent becomes a "dead," or an un-rechargeable battery. If you need fast-charge batteries, get the fast-charge type: They are specially designed to vent excessive internal pressure.

Wide Range Power Source

Although the charger is intended for use with a DC power supply rated up to 12 volts, it can also be used with the higher-voltage adapter-type supplies commonly available in the surplus market.

If the supplied voltage is insufficient for a particular battery (made up of several series-connected NiCd cells), you can install another power jack in series with J1, so two supplies can be series-connected. In this way you can regulate the input voltage from 3 to 24 volts and charge up to 12 NiCd batteries. Of course, you would have to increase the voltage rating of C1 and possibly increase the value of R1 to 2200 ohms.

Bear in mind that a "high-voltage" power source made up of two series-connected supplies doesn't charge the batteries any faster, nor—as explained earlier—should the high-voltage source be used in an attempt to fast-charge what are normally trickle-charge batteries. The only purpose for series-connected supplies is to provide more voltage than the fully-charged rating of the NiCd power pack—whether the "pack" is factory-wired or *homebrewed*.

Finally, since the charger is, in fact, a constant-current source, it can be used as such in your experiments and applications. ■

HIDE-A-WAY STEALTH

Avoid being harassed for having a police radar

By J. L. Pearson

NO ONE THAT VENTURES OUT ON OUR INTERSTATE HIGHWAY system would say that the 55 mph speed limit is being observed. Anyone that does observe it soon creates a moving roadblock and would find it safer to drive with the flow of traffic. The result is a gold mine for state and local municipalities that choose to use radar speed traps as a revenue source. In addition, it has been demonstrated in a Florida court that erroneous readings were easy to produce. Erroneous radar speeding summonses have been estimated to be as high as 30%. The driver-defensive response has created a huge market for radar detectors. That, in turn, has made the devices a target of theft. In addition, a detector clearly visible on the dash out on the open road can result in harassment. In some areas, although contrary to the Communications Act of 1934, ordinances against detection devices are in effect. All those factors combine to make a remote or hidden detector a highly desirable item.

Remote detectors usually have the antenna and RF electronics in a black box mounted behind the grill, under the front bumper, or even disguised as an add-on road light. A small control box and remote alarm may then be hidden under or in the dash-board. Those work, but the low placement of the antenna may result in blockage of the incoming radar beam by intervening vehicles. The cost is usually high, and the units may not be easily switched from car to car.

We will describe a simple, inexpensive way to allow any good superhet radar detector to be mounted remotely. No changes are made to the detector unit. It may be easily switched from car to car and can be mounted in any of a variety of unusual locations.

Review of Radar

Before we describe our circuit and system in detail, let's take a quick look at some microwave and radar basics, and why radar detectors are effective. We apologize beforehand to the professional microwave engineers among our readers for the lack of complex formulae in the explanation that will be presented. We are going to take a simple, practical, hands-on approach.

In all systems, active radars transmit a signal and then listen for a returning echo from a "target." A good analogy would be a person at night standing on the shore of a lake shining a flashlight (transmitter) out over the water looking for someone in a boat. Although the person in the boat might spot the flashlight being directed toward him from miles away, the person on shore could only spot the boat when it was near enough to reflect sufficient light back to the searcher's eyes (receiver). That distance would depend on many variables, one of which is just how reflective the target boat actually was.



RADAR DETECTOR SYSTEM

detector with this super trooper snooper

In a similar manner, the speed radars in use today direct an unmodulated beam at the moving target. The returning echo is shifted in frequency by an amount that is related to the speed of the target (doppler shift). It is then compared to the transmitted frequency by a heterodyne process within the receiver portion of the speed radar. The resulting beat is within the audio range. That is processed by additional circuitry and read out in miles per hour.

How reflective a target is affects the radar detection range. It is entirely possible for a large, relatively distant, flat-surfaced, semi-trailer rig to return a stronger echo than a much closer Fiberglas sports car when both are in the beam simultaneously.

The actual RF frequency used depends on the type of radar response desired. It varies from less than 10 MHz for modern computer-controlled, "over the horizon" radars to the millimeter-wave range of 30 to 300 gigahertz (1 GHz — 1000 MHz) for airborne and precision radars. At the microwave frequencies used by speed radars (10.525 GHz & 24.150 GHz), the analogy to light is valid. Just as the flashlight, the radar emits a beam.

Carrying the analogy one step farther, visualize the lights of an oncoming car at night. You can see the scattered and reflected light from the car around a bend or over a hill. In the same manner, because of reflections from other cars, buildings, trees, etc., a detector in the target can "see" an oncoming radar beam around corners and over hills. The target can see the transmitter before the radar has a clear shot at the target.

A beam of light may pass through substances transparent to it, or be blocked, absorbed, or reflected by substances opaque to it. The same principle applies to a microwave beam. The trick is to know what materials are microwave transparent or opaque. Most plastics, epoxies, dry wood, and plastic foams are transparent to microwaves. Fiberglass, being epoxy plus glass strands, is used for covering many radar-antenna openings. Non-metallic paints usually have little effect also. Rubber sheeting or any compound containing carbon or metal particles act to absorb or block the energy.

Any metal surface will act as a reflector. Wire mesh from window screen or a chain-link fence usually will reflect, but the size of the mesh openings is a factor here. Metal films on plastic may be made thin enough to see through but can act as reflectors for microwave energy.

A good, practical example of the reflection of microwaves can be seen by taking a look at some microwave relay towers (see Fig. 1). The reflective coating on an ordinary, flat-glass mirror is an excellent reflector of microwaves just as it is of visible light. It consists of a thin film, usually aluminum, that has been deposited on one side of the glass.

Likewise, the thin, semi-transparent, metalized, reflective plastic window insulating material available at building supply and auto specialty stores is also a good radar reflector and is ideal for our project. We have used it in a number of installations over the last eight years. The use of substances transparent to microwaves may be noted by observing the big golf ball like radomes used to enclose the rotating antenna of some airport radars.

Remote Indicators

In our application we can use the reflective property of metalized film to reflect radar signals toward the detector

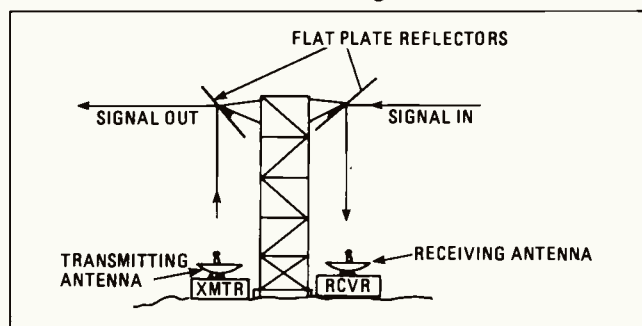

Fig. 1—To boost a microwave signal, a microwave mirror is used to reflect the signal into a receiver that feeds it into a transmitter whose signal is bounced off another mirror. Phone companies do that often for long distances.

even if it is hidden in the trunk. If no suitable spot can be found for trunk mounting, the suggestions for non-reflective mounts in Fig. 2 may be useful.

The detector unit we have used in all of our installations is Cincinnati Microwaves' *Escort*. It signals the driver with light and audio. A field-strength meter is provided on the detector, but the audio serves the same purpose by varying from a slow beep to a steady tone as the signal strength increases (distance closes). The tone has a different pitch for X-band and K-band radar, thus enabling one to determine just what kind of radar it is.

A working hidden detector, no matter where you place it, is useless unless we can tell when it detects something, so remote indicators are needed. We chose to use a microphone and amplifier at the hidden detector and a speaker under the dashboard to transmit the sound and alert the driver. A photocell monitors the detector signal light and lights a pilot lamp in the dash-mounted on/off switch. A volume control is provided on the circuit board for initial setup and could be located on the dash if desired. Experience has proven that the fewer adjustments available in a multi-user car, the better. Who wants a dash wired for hyper-drive anyway?

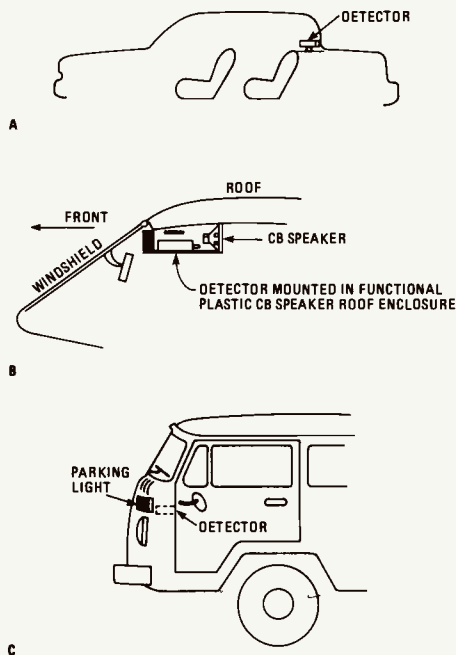
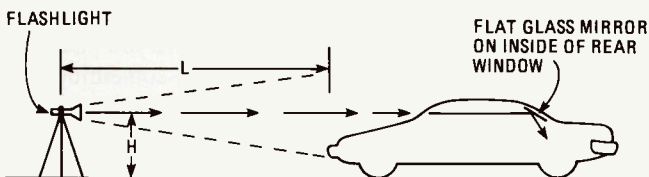

Fig. 2—If trunk mounting is not a possibility for your vehicle, the remote detector can be placed inside an add-on brake light (A), a fake roof-mounted CB enclosure (B), or even behind a forward-facing parking light (C).

Where to Mount It

Determining a good mounting spot in your vehicle is relatively easy. The slope of the rear window in most autos is just about right to reflect the signal down into the trunk through existing large holes in the horizontal, metal shelf behind the rear seat. The cloth-covered cardboard or plastic trim panel is usually considered to be transparent to radar and need not be cut.

The following night-time procedure will enable you to verify the proper locations for the detector and the metal film. Choose a dark spot and set up a flashlight about 20-ft. in front of the car (see Fig. 3), at the height of the center of the windshield. The beam should be level with the ground and shine through the windshield and rear window. Use a small, flat mirror placed against the inside of the rear glass to reflect the light beam down to the rear shelf. Mark the spot on the under side of the rear shelf where the reflected light falls with a spot of tape. If the spot will not allow for the mounting of the radar detector and remote circuitry move the mirror to another location and try again. By trial and error, it's usually possible to locate an opening in the metal (if any) under the shelf and a mirror placement that will be



H = APPROX HEIGHT OF WINDSHIELD CENTER
L = 20 TO 30 FEET SEE TEXT

Fig. 3—Using a camera tripod (or a friend with patience) is essential for determining the proper placement of the mirror and mounting bracket. Use a little tape to hold the mirror in place while marking the rear under shelf.

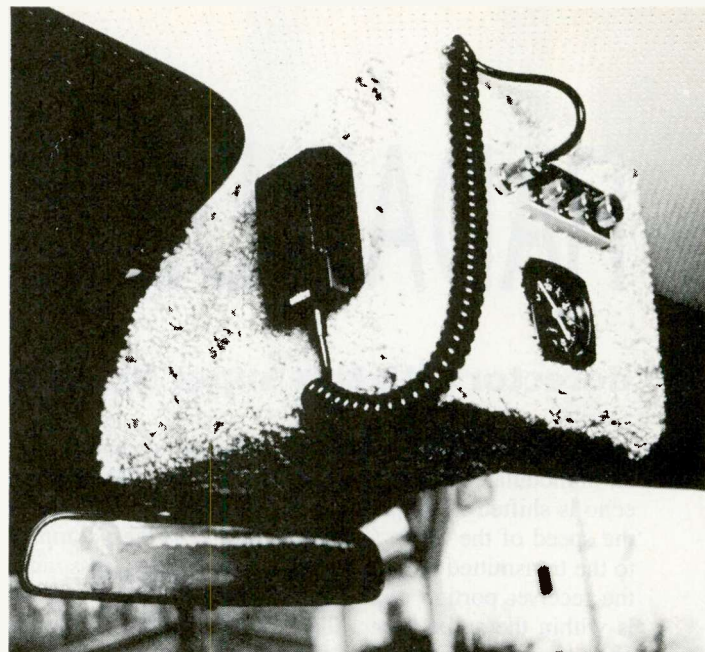

Suprise! Behind this CB/dash instrument enclosure is a cleverly concealed radar detector. The CB is functional, but the enclosure affords enough room for the detector.

satisfactory. The radar will be reflected in the same manner. Mark the location on the glass with a grease pencil for later installation of the reflective plastic material.

The specified reflective plastic sheet should be cut to shape and installed on the rear window according to the manufacturer's instructions. Keep it as small as possible and esthetically pleasing to avoid any conflict with vehicle regulations or your spouse. Although you can see through it, it has the additional benefit of decreasing the glare of following headlights at night time.

Remote Circuit Audio

The audio pickup and amplifier consists of MIKE1, U1, U2, and their associated components (see Fig. 4). MIKE1 is an electret condenser microphone. The unit specified comes with all coax and leads already attached. It requires a well-filtered DC voltage of a nominal 4.5 volts. That is provided by R1, R2, C1, and C2. The audio output of the mike element is coupled to U1 via C3. U1 is a variable attenuator that is controlled by a DC voltage applied to pin 2. As constructed, that control voltage is taken from a board-mounted, trimmer potentiometer (R3), which is set at installation time.

If a remote volume control is desired, R3 could be replaced by a dash-mounted potentiometer. The required leads would then be taken from the existing R3 board attachment points. Zip cord is ideal for that application because the potentiometer needs only two leads and a ground.

The output of U1 at pin 7 is input to the amplifier driver stage (U2, pin 6). Capacitor C6 is the interstage coupling capacitor. The remote-mounted speaker is directly driven by U2 via C9.

Light Sensor

The signal-alert light on the radar detector is monitored by the photo-resistive cell, SR1. The cell has a high dark resistance that falls to a few thousand ohms when illuminated. Trimmer potentiometer R9 and SR1 in series form a voltage divider. When the current through that series pair increases,

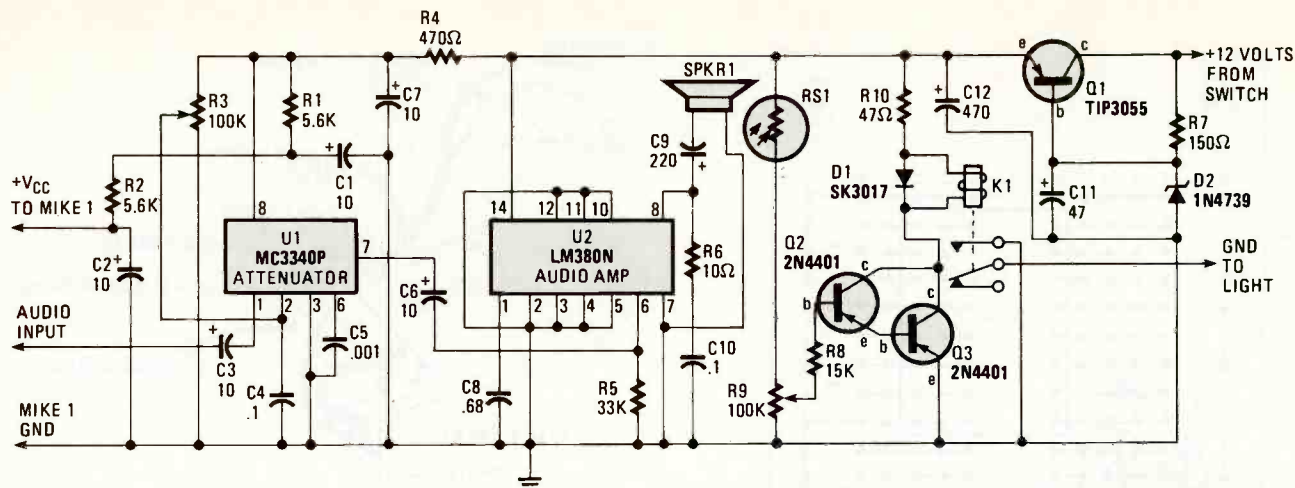

Fig. 4—Note that three wires run to the condenser mike in the remote circuit. That is because the mike requires external power to function properly.

a voltage is developed across R9. That causes the Darlington pair (Q2 and Q3) to conduct, actuating K1. As wired, the normally-open contact provides a ground to actuate the remote pilot light. Resistor R10 limits the current through the relay coil to the required value. D1 suppresses any spikes generated by K1.

Power Supply

The electrical system in the average auto provides an extremely dirty source of power. It may vary from about 10 to 15 volts, and all manner of nasty noise spikes abound. The regulator circuit shown has proven adequate to the task of taming that jungle. Resistor R7, capacitor C11, and Zener diode D2 provide a stable voltage to the base of the pass transistor Q1. The nominal 8.5 volts available at the emitter of Q1 is further filtered by C12. R4 and C7 decouple the stages for stable operation at all gain settings of R3. The nominal 4.5 volt mike element voltage and additional filtering are provided by R1, R2, C1, and C2.

Circuit Construction

The circuit may be built on the standard proto board specified (see Fig. 5). A drilled, etched, marked board and detailed manual are available for easier construction (see Parts List). The component leads will form the circuit runs in most cases. Where short jumpers are needed, #22, solid, bare hookup wire or the equivalent is used. The #22, stranded insulated wire is used for the remote leads and photocell connections. The shielded coax needed for the audio input is part of the mike element.

Note that C5 and a jumper between pins 3 and 12 of U2 are installed under the board. Note also that the Vcc bus foil is cut at column 12 so that the decoupling resistor, R4, may be installed as shown.

Mounting Bracket

Because of the wide variety of radar detectors and mount-

PARTS LIST FOR THE STEALTH RADAR DETECTOR

SEMICONDUCTORS

- D1—SK3017 silicon diode, 600-volt, 1-A, or equivalent
- D2—1N4739, 9-volt, 1-watt, Zener diode (Radio Shack 276-562 or equivalent)
- Q1—TIP3055, NPN silicon power transistor, $V_{cc} = 70$ volts, $I_c = 15$ -A (Radio Shack 276-2020 or equivalent)
- Q2, Q3—2N4401, NPN, silicon transistor (Radio Shack 276-2058 or equivalent)
- U1—SK3891, variable electronic attenuator, integrated circuit (Motorola MC3340P, or equivalent)
- U2—LM380N, audio-amplifier integrated circuit

CAPACITORS

- C1—C3, C6, C7—10- μ F, 16-WVDC, axial electrolytic
- C4, C10—.1- μ F, 50-WVDC ceramic disc
- C5—.001- μ F, 50-WVDC ceramic disc
- C8—.68- μ F, 15-WVDC, radial-lead, Tantalum
- C9—220- μ F, 35-WVDC axial-lead, electrolytic
- C11—47- μ F, 16-WVDC radial-lead, electrolytic
- C12—470- μ F, 35-WVDC axial-lead, electrolytic

RESISTORS

- (All are 1/4-watt, 5% units unless otherwise specified).
- R1, R2—5600-ohm
- R3, R9—100,000-ohm, PC-mount trimmer potentiometer (such as Radio Shack 271-338)

- R4—470-ohm
- R5—33000-ohm
- R6—10-ohm
- R7—150-ohm, 1/2-watt
- R8—15000-ohm
- R10—47-ohm, 1/2-watt

ADDITIONAL PARTS AND MATERIALS

- K1—5-volt, 75-mA, SPDT miniature relay (Radio Shack 275-246 or equivalent)
- MIKE1—Electret condenser mike element
- SR1—Cadmium sulfide photo resistor
- S1—SPST, illuminated rocker switch
- SPKR1—4- to 6-ohm speaker
- PC board (Dirijo PCRD-1 or proto board), 4 PC-board mount standoffs, # 24-gauge sheetmetal bracket (as required), sheetmetal screws, cable clamps, paint, epoxy, # 22 bare solid and insulated stranded wire, 4-conductor # 22 stranded wire, aluminized mylar sheet reflector as required (see text).

A drilled, etched, part-marked, PC board is available for \$4.95 (plus \$2 for shipping and handling) from Dirijo Corp., PO Box 212, Lowell, NC 28098. They also produce "The Radar Evader Manual" which deals with other radar evasion techniques and costs \$12.95 (plus \$2 for shipping and handling) if purchased separately, or you can pay \$15.95 (plus \$2 for S&H) to order them both.

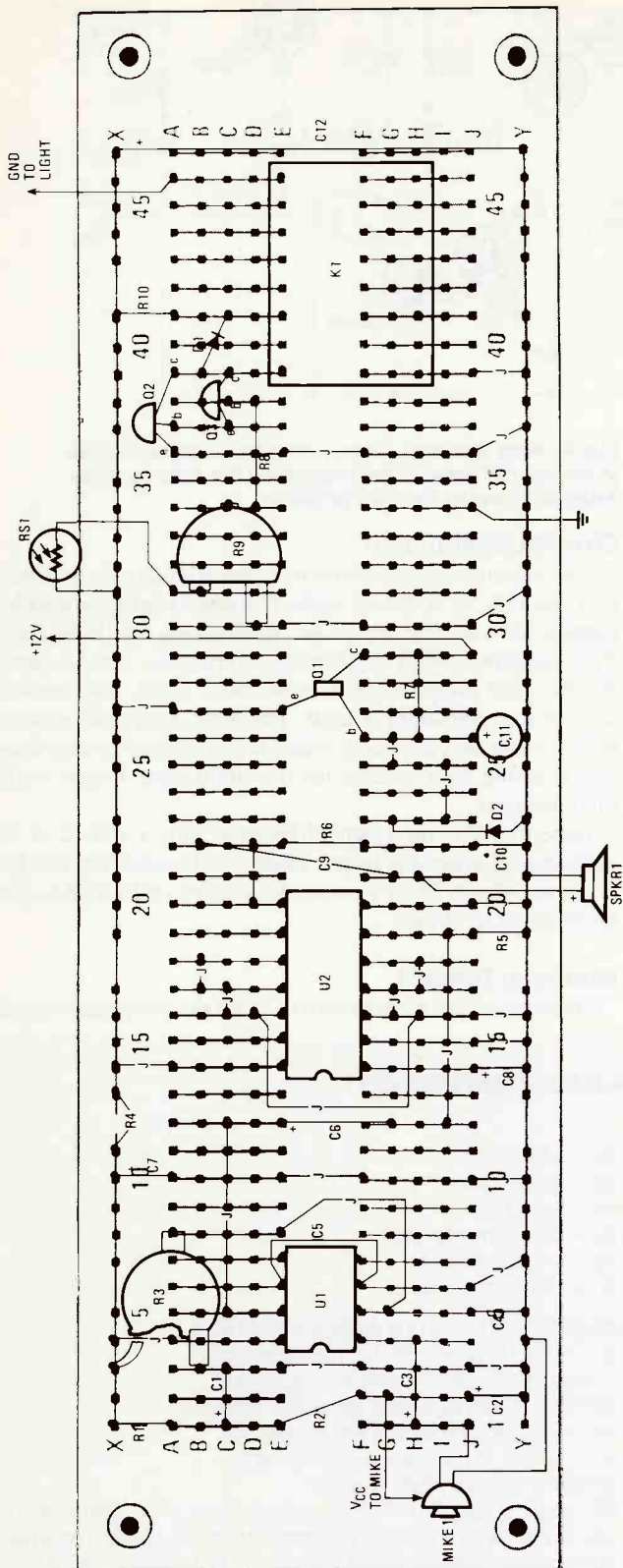

Fig. 5—Be sure to place the jumpers on the circuit board before placing the components on, as some of them can be run under components. An example of that is the one beneath R3. You may wish to run some components, like capacitor C5, under the board, but be sure C5 is connected as close to the pins of V1 as possible. Electrical noise in a car can creep into your circuit, so C5's placement is important.

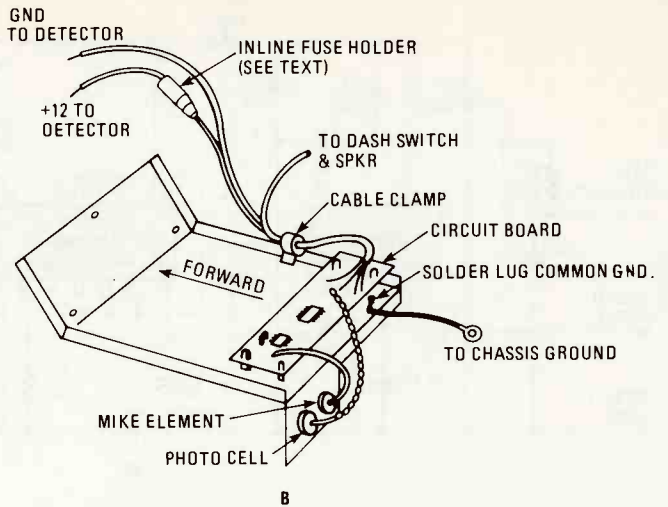

Fig. 6—If you don't have any sheet-metal working tools, you can place the sheet in a vice, cushioning it between two boards lined up at a bend line, and bend it by hand. If you wish you can hinge two pieces of wood to make a sheet-metal brake that will provide leverage.

ing positions available, a fits all mounting-bracket design has not been provided. We will, however, give some guidelines and a detailed drawing of a bracket similar to that shown in our trunk-mounted installation (see photo).

Some general attributes should be included in the design of your bracket:

- Provision must be made to support the photocell and the pickup mike element adjacent to the detector's warning light and speaker openings.
- Velcro attachment of the radar detector to the bracket is recommended if the detector is to be transferred to any other vehicles.
- A mounting for the circuit board is required.
- Some provision to vary the inclination of the mounting bracket is needed to allow "peaking" of the signal as mentioned in the installation section.
- The material used should be sturdy enough and secured to the auto structure to withstand the normal vibrations experienced in an automobile.
- Do not create a safety hazard by allowing sharp corners, edges, or other hazardous parts to be placed anywhere in the passenger compartment.
- Provide proper fuse protection for the detector and all other circuitry.

You should design your bracket so that the sensors are in front of their corresponding components on the detector. They can be held in place with epoxy.

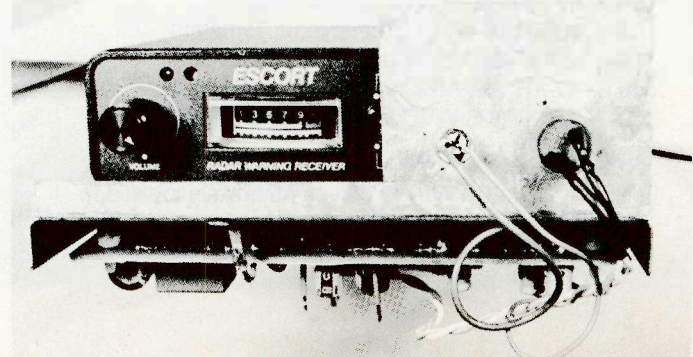

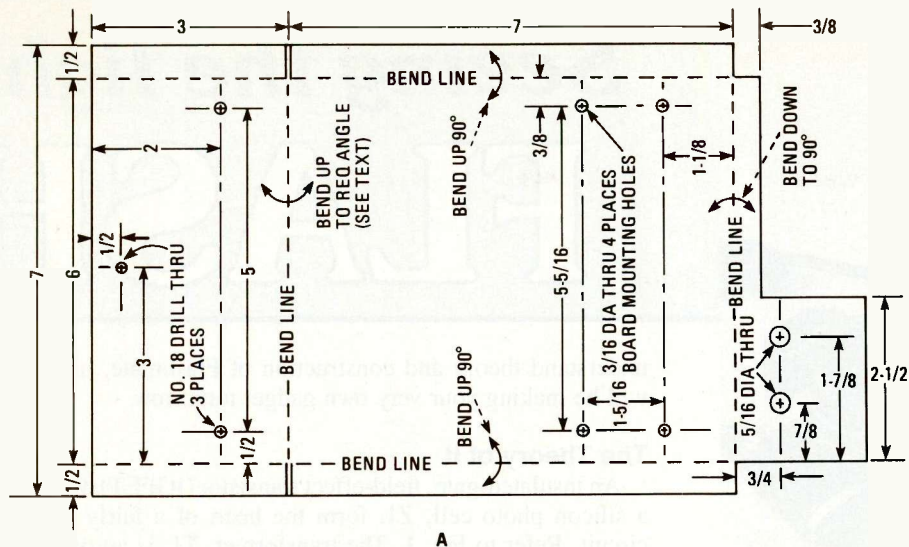

Fig. 7—The holes for sensor placement are, of course, dependant on your radar detector, and are shown here only as an example. When gluing the audio and photo-sensitive sensors in place be sure not to cover the sensors with epoxy.

The mounting bracket will vary with the make of the vehicle and the desired mounting location. Fabricate your bracket following the general outline shown in Fig. 6.

Installation and Testing

The installation procedure will vary with the make and model of your vehicle. In general, where any wires must pass through metal, they should be protected by rubber grommets. Run the needed wires through available wiring raceways when possible.

Be sure to provide a proper fuse at the +12-volt source so that the entire circuit is protected. The remote control panel and speaker placement are also vehicle dependent. Any 4-16-ohm small diameter speaker will do. The speaker can usually be glued to the under-dash structure using a silicone adhesive.

Add-on panels containing various switch and pilot light combinations are available at auto accessory or electric hobbyist stores. When possible, we have used the illuminated rocker switch specified in the Parts List and mounted it directly in the dashboard.

Since most speed cops are not very cooperative in providing test signals, and most hobbyists do not have microwave sources available, a good setup and test range can be provided by the microwave door openers in shopping centers and such. Their signal is identical to the X-band radar signal. They may be easily located by the false alarms they produce

The reflective film not only functions well for our application, but looks good also. When placed at the right height, it will help cut down the glare from headlights behind you.

in your detector. Intrusion detectors installed in many banks will also work, but the employees tend to panic at suspicious autos in their parking lots.

If you are not sure just how transparent or opaque to microwaves a substance may be, use the following procedure. Aim your detector toward the chosen signal source. Place the material in question over the antenna (usually the front)

of the detector and note the effect on signal strength. Most plastics, styrofoam, thin dry wood, cloth, etc., will have no noticeable effect. You may see some variations caused by reflections and standing waves that will exist in most practical environments. Please note that substances transparent to the X-band are usually OK at the higher K-band frequencies. The only real test of the K-band characteristics, however, is a working K-band radar or signal source.

After installation, the following setup procedure should be used. Aim your vehicle at the source. Get far enough away so that you have a weak signal indication. Adjust the angle of the mounting bracket for maximum signal strength. Set the detector volume control to maximum and adjust the level potentiometer (R3) on the circuit board for the desired volume inside the vehicle. The photocell sensitivity adjustment (R9) should also be set to allow the remote light to follow the action of the detector-alert light.

One potential problem could exist with the trunk mount, and that is blockage by rear-seat passengers. Our experience has been one of no degradation in apparent sensitivity. Perhaps all of our friends are airheads. A more likely explanation is that multiple reflections are present in the passenger compartment, and the microwaves have numerous paths to reach the rear reflector. The detector should now function with the same apparent efficiency as it did mounted on the dash or your sun visor. It will also be less of a temptation to a thief or provocation to law enforcement personnel. ■

Notice that no metal interferes with the radar detectors "view" of the reflective film. That allows it to receive the maximum signal from the metalized-film coating.

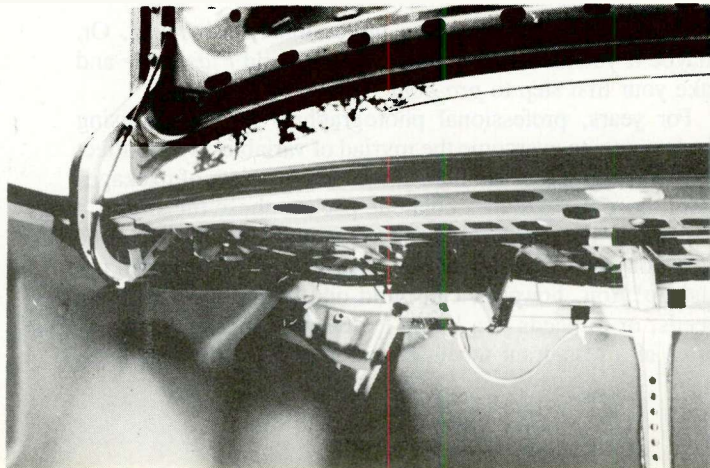

Seeing the light

FLASH



understand theory and construction of Flashmate, and you will be making your very own gadget tomorrow.

The Theory of It

An insulated-gate, field-effect transistor (IGFET), Q2, and a silicon photo cell, Z1, form the heart of a fairly simple circuit. Refer to Fig. 1. The transformer, T1, is an ordinary audio-output type, but it's reversed in the circuit. A sudden flash from a photoflash unit detected by Z1 sends a voltage pulse through the low-impedance winding of T1 via R1. That voltage pulse is stepped-up in T1's 500-ohm, primary winding before being rectified by Q1. Transistor Q1 is used as a diode; its emitter lead was snipped off close to the case. Q1 then charges C1 to a value proportional to the amplitude of the electrical pulse generated by the light from a flash unit.

Capacitor C1 controls the current flowing through Q2, which has a very high-input impedance. The current through Q2 is read by meter M1 (a 0-50- μ A DC unit) which has been calibrated in *f*-stops. The extremely high internal resistances of Q1 and Q2 will allow C1 to retain its charge for several minutes; more than enough time for you to take your reading of M1. The charge on C1 is shorted to ground and returned to zero volts by depressing RESET button, S1. Flashmate is ready to read the next photoflash.

Trim potentiometers, R7 through R14, are adjusted to values which will yield correct readings for corresponding film sensitivities, or exposure indexes. Depending on your age or photo experience, you may refer to the exposure indexes as ASA, ISO, or even EL. All are indicative of your film's *speed* and Flashmate must be calibrated to measure the proper exposure for each type of film you anticipate using, now or in the future.

Putting It Together

The main consideration in selecting a cabinet or plastic box, is having space enough to mount all the controls and meter along with the photo cell. Some thought to layout should be given to provide a practical configuration. Remember, the photo cell, Z1, must face the flash when it is fired, and since you would be near the camera, you would want the meter, M1, either facing you or upward for easy reading. Place some window material (clear plastic) over the photo cell to protect it from damage and dirt.

Wiring of Flashmate does not introduce any critical parts or lead layout. A printed-circuit board or a piece of perfboard will do the job. Take the easy way out—use perfboard.

Start by laying out the parts to be mounted on the panels of the box. Make sure you leave enough room to operate all switches. The perfboard can be cut to fit behind meter M1; mount it by the two contact posts of the meter. If you do this, indicate on the board next to the posts which is positive and which is negative.

YOU MAY HAVE A CAMERA THAT HAS ALL THE AUTOMATIC features a photobuff would ever ask for. Almost every shutterbug has one these days. But look ahead. In the future you may want to step up to studio photography with more than one electronic flash going off at a time. Then that little computer wheel on the back of the flash unit cannot pick the right *f*-stop for you. What if the unit has aged some or the batteries are not at full charge? What if you are using more than one flash unit and each one is a different type, and placed at different distances from the subject? Do you average their readings? Do you guess and bracket your exposures widely? Do you punt?

At today's film and processing prices, you are better off knowing the right *f*-stop on the first shot, with all the variables cranked into the equation. If you are a bad guesser like me, the smiling young lady in the yellow hut in the mall parking lot should be listed as one of your dependents come next April 15.

What you really need is a professional flash meter. Or, maybe if you are a smart cooky, you'll build *Flashmate* and take your first step to *pro-dom*.

For years, professional photographers have been using flash meters to overcome the myriad of variables which affect flash photography. The meters come in a variety of packages from those the size of a cigarette pack to those the size of a cigar box. They all have varying features, but they share one common denominator—a price tag of \$100 and up, and up, and up! You, however, can build one tailored to your own needs, or to needs you haven't even discovered yet, for the price of a restaurant meal. Take a hard look at the easy-to-

with... MATE

Know once and for all what to set your camera lens at no matter how many lights and reflectors you use!

By Frank I. Gilpin

Consideration is given to layout components and controls. The meter (M1) and ASA selector switch (S3) are on top of the front panel. Reset and Power switches (S1 and S3) are on side panel and the photo cell (Z1) is on the top panel. The exact layout can be made differently to suit the plastic or metal box you use and views you may have as to what is best for you.

Be cautious: The manufacturer of the IGFET, Q2, has wrapped a shorting wire around all four of its leads. Keep the wire in place until the transistor has been wired into the circuit completely to prevent the IGFET from self-destructing. Even a tiny static charge is enough to zap the unit into Never-Never Land.

Calibration

After the wiring of Flashmate is completed and double-checked, you will need to calibrate your device for the eight most-used ASA values. The schematic diagram in Fig. 1 indicates the most popular exposure indexes between 25 and 1,000, but you can substitute your own choices with wide latitude offered by the large values of trimmer potentiometers R7 through R14. Before you begin, set all trimmer potentiometers to their mid-range position.

To calibrate your finished unit, you'll need a reliable flash unit, a tape measure, and a long hallway, empty garage, or big room. The best kind of flash unit to use for calibration is the type which has an AC adaptor. That type is more likely to operate consistently at a full charge.

An easy method of putting the meter at a good working level is to set it on a stool such as a bar stool, or a short ladder.

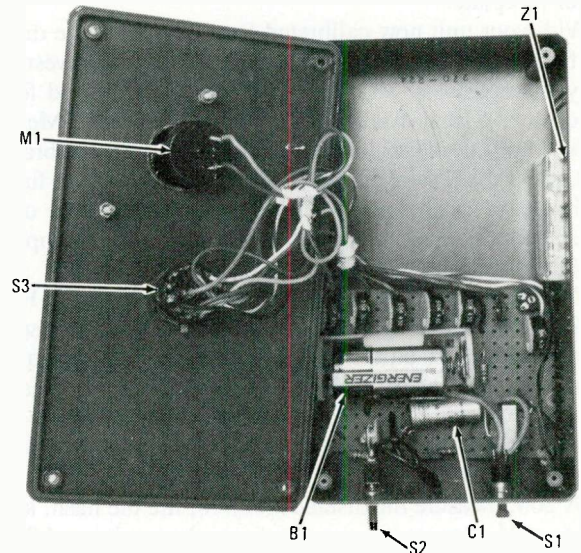

Set the computer dial on your flash to the highest ASA used on your meter, say 1,000. Read the distance required for an exposure at f -22. For most small electronic flash units it will be in the neighborhood of 25 feet. Measure to a spot 25-feet distant from Flashmate. Make sure the ready-light on the flash unit is lit and fire the flash at Flashmate after turning the unit on and setting ASA switch, S3, to its highest setting. The needle of meter M1 should have gone way upscale, possibly even pegged. Adjust R14 until the needle rests just inside the full-scale mark. Adjust R4 so that the final setting of R14 is close to the stop for minimum resistance. That initial setting will provide enough resistance range for adjustment of the remaining trimmer potentiometers.

You will, of course, have to remove the transparent cover from the meter face to mark the calibrations. Do this very gently so as not to damage or bend the sensitive needle and coil movement. With a sharp pencil, mark the first calibration of f -22. (Turn page)

With a sharp pencil, mark the first calibration of f -22. (Turn page)

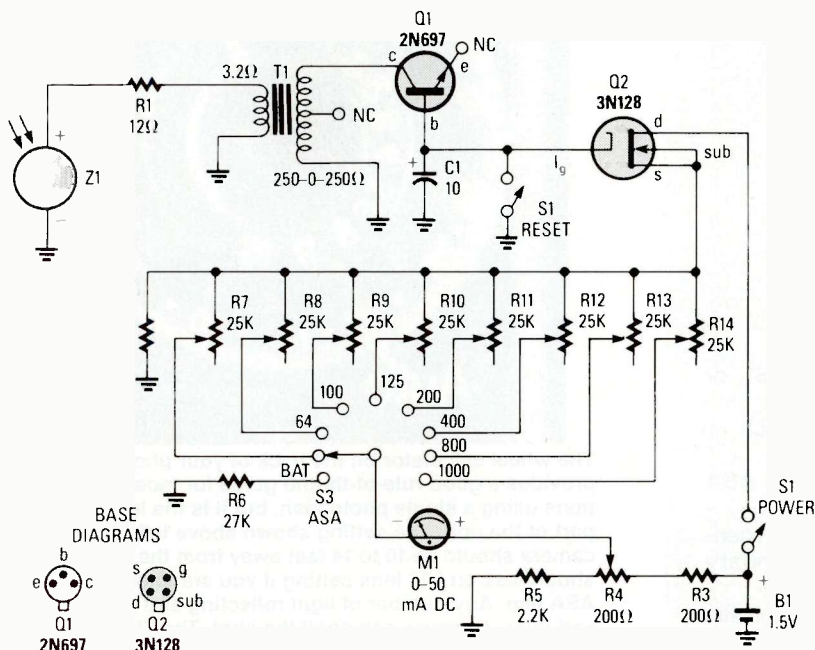

Fig. 1—You know a project will be accurate when everything is adjustable. You won't have to rely on the tolerance of the parts or how effective the circuit design handles the pulses created by Z1.

The Flashmate light meter is an evolved version of a unit designed for one ASA film speed and was one-quarter of the size. The final model, as featured here, was used for studio work. A smaller version might travel with you in your gadget bag for on-site sessions. The window at the top of the unit protects the photo cell from dirt and damage.

One neat technique is to cover the original meter faceplate with an adhesive-backed label big enough to cover the markings. Trim off the excess label with a sharp modeller's knife or razor blade. Make a small pencil mark at each calibration and make a note of its value on another piece of paper. Later, use transfer letters on those marks for a professional-looking meter faceplate.

With your unit now calibrated for *f*-22, check the dial on the flash unit once more. Set the ASA at the next lowest used on your meter, say 800. Note the distance required for an exposure at *f*-16; it would probably be about 21 feet. Measure 21 feet from the flash meter. Set S3 to the next calibration, 800, press the RESET button, S1. Then, from 21 feet, fire the flash unit at Flashmate. Adjust R13 until the needle of M1 rests about one half-inch or a little less from the first upscale calibration. Make that calibration *f*-16.

Things get very repetitive from here on. Reset the Flashmate and switch S3 to the next highest ASA, 400, and set the ASA on your flash unit to 400. Measure the distance required for an exposure at *f*-16; probably about 17 feet. Pop the flash at Flashmate from 17 feet and adjust R12 until the needle rests on the *f*-16 mark previously made on the meter faceplate.

Use the next setting on the flash meter, 200, set the flash for ASA 200, measure the distance for *f*-16, fire the flash, adjust R11 for *f*-16. Repeat this process for each remaining ASA on

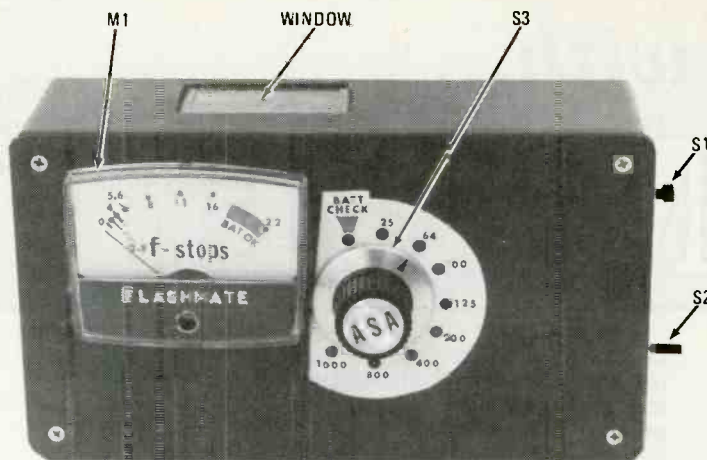

S3, adjusting potentiometers R10 through R7 until the needle reads *f*-16.

When you have adjusted each of the variable resistors, set ASA switch S3 to a mid-range, say 200 ASA. Measure off the distance for *f*-8 at 200 ASA, fire the flash and note the spot where the needle comes to rest and mark that *f*-8. Repeat this process at ASA 200 for *f*-5.6, *f*-4, *f*-2.8, and *f*-2 if there is room on the face, though it's unlikely you will ever use the last setting in the practice of your art.

The only remaining calibration is the voltage check. With a fresh C-type dry cell in Flashmate, switch S3 to BAT. An acceptable range is from full-scale, or *f*-22 to about two thirds of the way toward *f*-16. You can color this small range on the

(Continued on page 162)

PARTS LIST FOR FLASHMATE

SEMICONDUCTORS

- Q1—2N697 NPN silicon transistor (any similar type transistor will do)
- Q2—3N128 IGFET (ECG-220, Radio Shack 276-2036, or equiv.)
- Z1—Silicon photo cell, such as Radio Shack's 276-124 rated 0.2 amp at 0.42-volt DC

RESISTORS

- (All fixed resistors are 1/2-watt, 5% units)
- R1—12-ohm
 - R2—2700-ohm
 - R3—220-ohm
 - R4—200-ohm trimmer potentiometer
 - R5—2200-ohm
 - R6—27000-ohm
 - R7—R11—25,000 trimmer potentiometer
 - R12—10,000-ohm trimmer potentiometer
 - R13, R14—5,000-ohm trimmer potentiometer

ADDITIONAL PARTS AND MATERIALS

- B1—1.5-volt, C-size, dry-cell battery
 - C1—10-μF, 200-WVDC, electrolytic capacitor
 - M1—0-50-μA, DC meter (Radio Shack 270-1751, or equiv.)
 - S1—SPST, momentary-contact, pushbutton, switch
 - S2—SPDT, toggle switch
 - S3—1-pole, 12-position, non-shorting, rotary ASA switch (Radio Shack 275-1385 or equiv.)
 - T1—Miniature, audio-output transformer; 500-ohm center-tapped primary winding; 3.2-ohm secondary winding; turns ratio of 12.5 to 1
- Plastic cabinet, battery holder for B1, knob, clear plastic window, wire, solder, etc.

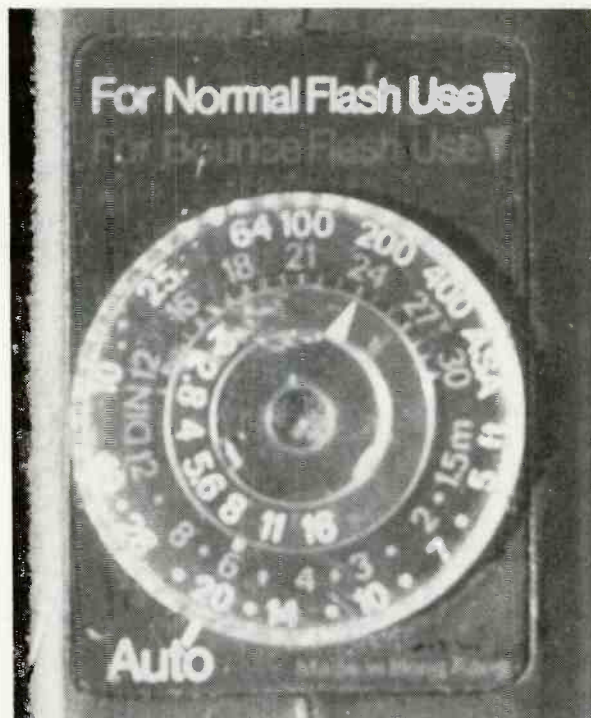

The wheel calculator on the back of your photoflash unit provides a good rule-of-thumb guide for most strobe situations using a single photoflash, but it is the least accurate part of the unit. The setting shown above tells you that the camera should be 10 to 14 feet away from the subject, you should use an *f*-16 lens setting if you are shooting with 200 ASA film. Any number of light reflecting and absorbing variables, however, can spoil the shot. The Flashmate will save the day by providing the correct camera setting for the shot.

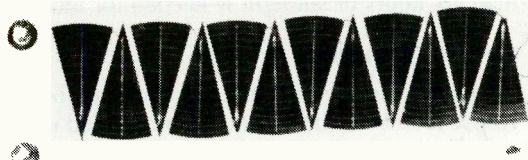

SOLAR POWERED HOUSE NUMBER

This solar-powered project acts like a lighthouse to nighttime visitors who may be unfamiliar with your area!

□SEARCHING FOR A PARTICULAR HOUSE ON A DARK, UNFAMILIAR street can be a frustrating business to your guests. Besides the embarrassment of ringing or knocking at the wrong door, the home owner may panic at the sight of an unfamiliar face—the next thing you know the *boys in blue* could be breathing down your guest's neck. However, you can nip that little problem in the bud by installing a *Solar-Powered House Number* (see photos), which is nothing more than an illuminated house-number that switches itself on at dusk and switches off six hours later.

Illuminated house numbers are a great idea but they invariably have one drawback—you have to remember to switch them on at dusk and off again before you retire. They also tend to be expensive. By contrast, the operation of our circuit is completely automatic and its illumination is independent of the main supply.

Two rechargeable batteries, which are topped off (charged up) during the day by a solar-cell array, provide power for up to 30 high-intensity LED's that backlight a number mask attached to a tinted plastic backing. The solar cells are wired in series and sandwiched between two sheets of acrylic plastic to protect them from the weather. The use of a solar-cell array dictated that the circuit be carefully designed to minimize power consumption.

The project is controlled by a light-dependent resistor (LDR), which is used to monitor the ambient light level. As dusk falls, the LDR's resistance increases to a certain critical level, at which the circuit triggers and illuminates the LED's. The LED's are driven in series pairs, a technique that enables two LED's to be driven with the same current as a single unit. A multiplexer ensures that no more than three LED pairs (out of a possible total of 19) are turned on at any given time.

Finally, we have the automatic dimmer (controlled by a second LDR) to gradually reduce the drive current to the display as it gets darker, while a timer switches the display off

after six hours to minimize battery drain. An optional *retrigger* switch can be included in the circuit to reset the timer circuit for six additional hours of operation if required.

Most of the components are mounted on two printed-circuit boards and housed in a plastic case that can be waterproofed.

Batteries

Initially, we had proposed a simple solar-charged battery circuit consisting of three or four small nickel-cadmium (Ni-Cd) cells and a preassembled solar panel costing about \$30. Unfortunately, both of those choices proved unsuitable. The solar panel simply lacked capacity and a Ni-Cd battery of suitable capacity turned out to be more expensive than we had anticipated.

The alternative was a sealed lead-acid battery (manufactured by Gates Energy Products). Such batteries are available in several sizes, with the smallest (see photo) equivalent in size to the familiar "D" cell. Strictly speaking, the battery is larger than necessary for this project—two such cells wired in series could run the circuit for at least a week without recharging. While that in itself is desirable, it also means that the preassembled solar-cell package lacks sufficient capacity to take full advantage of the batteries.

Another impressive specification of the Gates cells is their low internal resistance and consequent high discharge capability. The application manual lists the D cell as providing a maximum power transfer of 130W at 130 amperes! While that's of no particular advantage to the Solar-Powered Street Number, there are other situations where it could be used to advantage.

Solar-Cell Array

Having settled on the batteries, the next task was to devise a

The optional retrigger switch (S1) allows the timer to be manually reset for an additional six hours of operation at any point in the cycle. Diode D1 stops the clock at the end of the six-hour period by pulling pin 11 of U1 high, preventing U1 from commencing a second six-hour period at the end of the first. That's due to the fact that it will still be dark after the first six hours, which means that pin 12 (reset) of U1 will still be low.

The output of U2a also connects to the anode diode D3. Another diode (D2) is connected in series with pin 3 of U1, while the cathodes of D2 and D3 connect to a common control point. The polarities of D2 and D3 are such that whenever either of their inputs (anodes) is high, the control point is also high. At other times, the control point is held low by pull-down resistor R4. In order for the multiplexing and LED drive circuitry to be enabled, the control point must be low. It follows, therefore, that in the period between U2a being triggered (sunset) and U1 completing its count (Q14 high), the display is operating.

U3 (a 4017 decade counter) is used to multiplex the display. Because our circuit only calls for a five-way multiplexer, the pin-1 output of U3 is connected to pin 15 (reset) via R7. When pin 1 goes high, U3 resets almost immediately, so one of its five output lines (0 to 4) is high at any given time, while the circuit is operating.

U3 pin 15 (reset) is also connected to the anode of diode D4, which means that normal resetting can only occur when D4 is reverse-biased. At other times, the reset pin will be held low and U3 prevented from resetting. To appreciate the significance of that, it's necessary to consider the circumstances whereby D4 will be forward-biased.

The cathode of D4 is connected to pin 10 of U2b, whose inputs are connected back to the D3/D4 junction. Recall that when that control point is high, the multiplexing circuitry is disabled. Because U2b is connected as an inverter, a logic high at the control point is translated into a low on the cathode of D4. The diode is thus forward-biased, inhibiting the reset function of U3.

Clock pulses for U3 are supplied by U2d, a simple Schmitt oscillator with a nominal output frequency of 110 Hz. The oscillator is enabled when pin 4 of U2c, which has one of its inputs connected to the D2/D3 control point and the other to the pin-1 output of U3, goes high. Thus, the clock will be inhibited when both inputs to U2c are high, (i.e., when the D2/D3 junction is high and the number-5 count has been reached).

Normally, a number-5 count will reset the multiplexer. However, at the completion of the six hours, pin 3 of U1 goes high and prevents U3 from resetting. At the same time, the multiplexer clock is stopped (due to the multiplex inhibit and number-5 count), and so the 4017 stops counting. The pin 1 output of U3 remains high while all other outputs remain low, keeping all display drivers turned off.

The display drivers (Q2-Q6) are driven by the 0-4 outputs of U3 via 4700-ohm current-limiting resistors. Up to three LED chains—consisting of two LED's wired in series with a 27-ohm limiting resistor—can be driven by each transistor. The chains are connected between the collectors of their respective driver transistors and the collector of Q1, which forms part of the dimmer circuit.

Note that the LED's are purposely not numbered. That's because some will be omitted or included, depending on the number to be illuminated. Also, note that there is a jump in numbers from the display's limiting resistors to the biasing



The solar array uses two lead-acid rechargeable D-cell batteries, which have a capacity of 2.5 Ah. Then as day fades to night, the batteries are called on to provide power to the circuit.

resistors for the display drivers—a portion of the circuit has been omitted to save space.

The dimmer circuit consists of PNP transistor Q1, LDR2, R5, R6, and Q1. Q1 has its emitter connected to the positive supply rail and its collector to all of the LED anodes. The LDR simply provides base current for the transistor. During twilight, more base current is provided for the transistor so that the LED's operate at maximum brightness. As the level of ambient light falls, less base current is provided for Q1 and the LED's dim. R6 is adjusted after installation to provide a suitable minimum level of brightness, according to the installation.

Note that the drive current for Q1 is not derived from the negative supply rail, because that would result in a wasteful base current flowing during the day, when the LED's are not operating. Instead, the base current is derived from the pin-1 output of U3. When U3's operation is inhibited, pin 1 remains high and thus no current flows to the base of Q1. (Remember, for a PNP transistor to turn on, its collector must be more negative than its base, and its base more negative than its emitter.)

Construction

Construction can be divided into four main areas: the solar panel; the display; control electronics, and the preparation of the enclosure. Because the solar panel must be sealed after assembly and then left to dry, it should be attended to first. You should have the following parts handy before beginning: two pieces of acrylic plastic (about 195 x 60mm); 12 solar cells; 300mm of enamelled copper wire; four machine screws and nuts; eight washers; four solder lugs, and a 1N4001 diode (which is not included in the layout).

Having trimmed the two pieces of acrylic to size, clamp them together and drill a hole in each corner to accept the machine screws. That done, drill two smaller holes at one end of one sheet to provide access for the output wires.

The solar cells should now be connected in series using small lengths of the tinned copper wire. Two longer lengths (about 200mm and 40mm) are used for the output connections. Note: The cells are extremely brittle and will crack if mishandled. They can also be damaged by excessive heat, so treat them gently.

Once the cells are all interconnected, smear a dab of

silicone rubber compound on the back of each and lay them out on the lower piece of acrylic sheet, as shown in Fig. 2. Feed the output wires through their respective holes in the lower acrylic sheet and connect the positive lead to the anode of the 1N4001 diode. Next terminate the cathode and negative leads with solder lugs.

Construction of the solar-panel array can now be completed by running a fillet of silicone rubber compound around the edge of one of the acrylic sheets, inserting spacers—two small washers at each screw should do the trick—between the two sheets to avoid crushing the cells, and then fastening the two sheets together using machine screws and nuts.

We also used solder lugs to terminate the external leads, which should be added during the final assembly. Don't forget to seal the holes for the output wires from the cells.

The circuit itself is built on two printed-circuit boards: the control board measuring 73 × 44mm; and a display board, measuring 180 × 95mm, templates for which are shown Fig. 3 and Fig 4, respectively.

Begin by assembling the control board according to the layout diagram shown in Fig. 5. Note that the IC's are CMOS devices and therefore static and thermal sensitive, so be sure to solder their supply pins first to enable the internal static protection diodes. We used printed-circuit stakes (nine in all) to terminate the external wiring connections.

The display board has been designed to accommodate various LED combinations to form any one or two digit number. If you require a three-digit number, then you will have to wire the display using matrix board or Veroboard.

Because the number required will vary, the LED locations are represented by numbers on the parts layout diagram (see Fig. 6). To select a certain number, all you have to do is install LED's and wire links (jumper connections) at the locations indicated in Table 1.

For example, to make up the number 5, install high-efficiency LED's at locations 1, 2, 3, 4, 7, 9, 10, 14, 15, 16, and 18; dummy LED's at 2, 6, and 17; and links at L2 and L4

All the electronics (except for the solar-cell array) are mounted in a plastic project box. The solar array should be mounted away from obstructions.

(which is also the location of LED 19). The dummy LED's, by the way, are low-efficiency types. In use, they are simply blocked from view by the number mask on the display panel. Do not omit the dummy LED's. They are necessary because all LED's must be connected in series pairs to avoid variations in brightness.

All that remains now is to mount the various parts into the plastic zippy case. First, cut a piece of acrylic plastic to

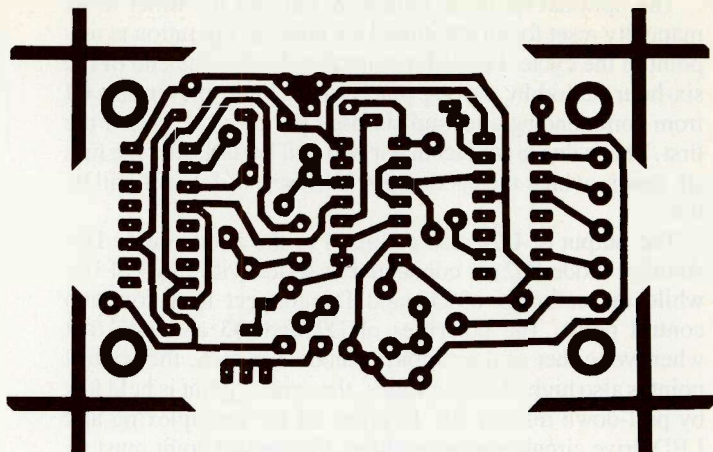
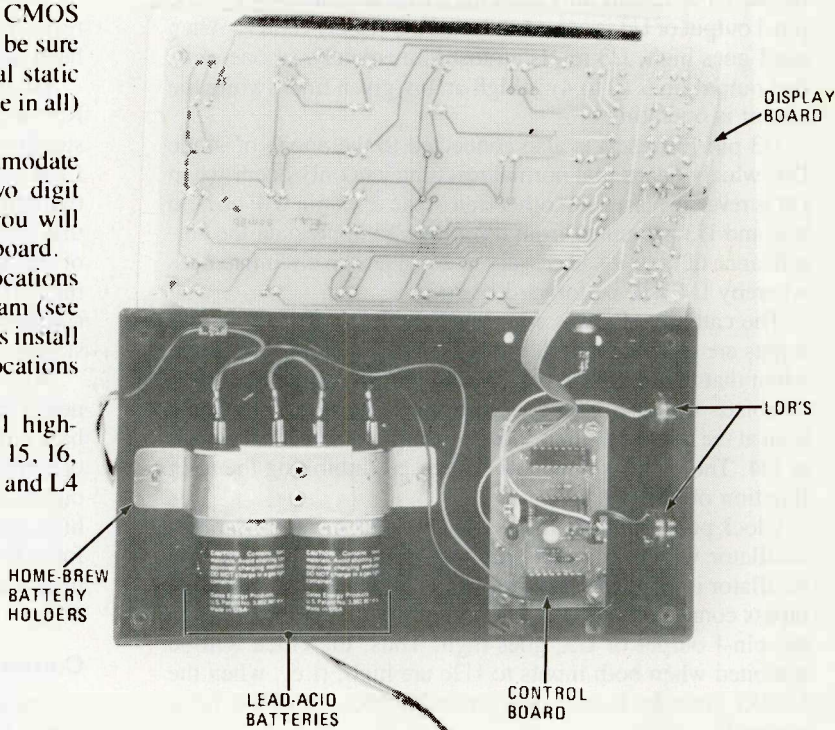

Fig. 3—This full-scale template of Solar-Powered House Number's control board (measuring 3 × 1 7/8 inches) can be copied from the page and used to etch your own printed-circuit board.



replace the original aluminium lid and attach to it a cardboard number mask representing your street number. The display board can then be mounted behind the number mask using 25mm screws as stand-offs. If you like, you can use a colored filter behind the mask to improve daytime visibility.

The control board is mounted to the base at one end of the case (see photos), and secured using machine screws and nuts. The two LDR's are mounted on the end of the case,

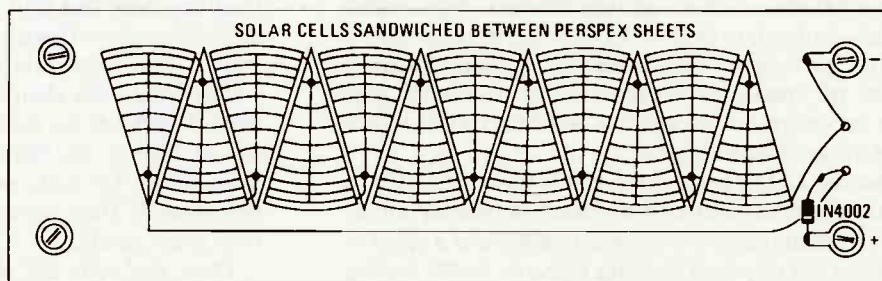

Fig. 2—The photocell array for the project is made from 12 photocell sections sandwiched between two pieces of clear acrylic plastic.

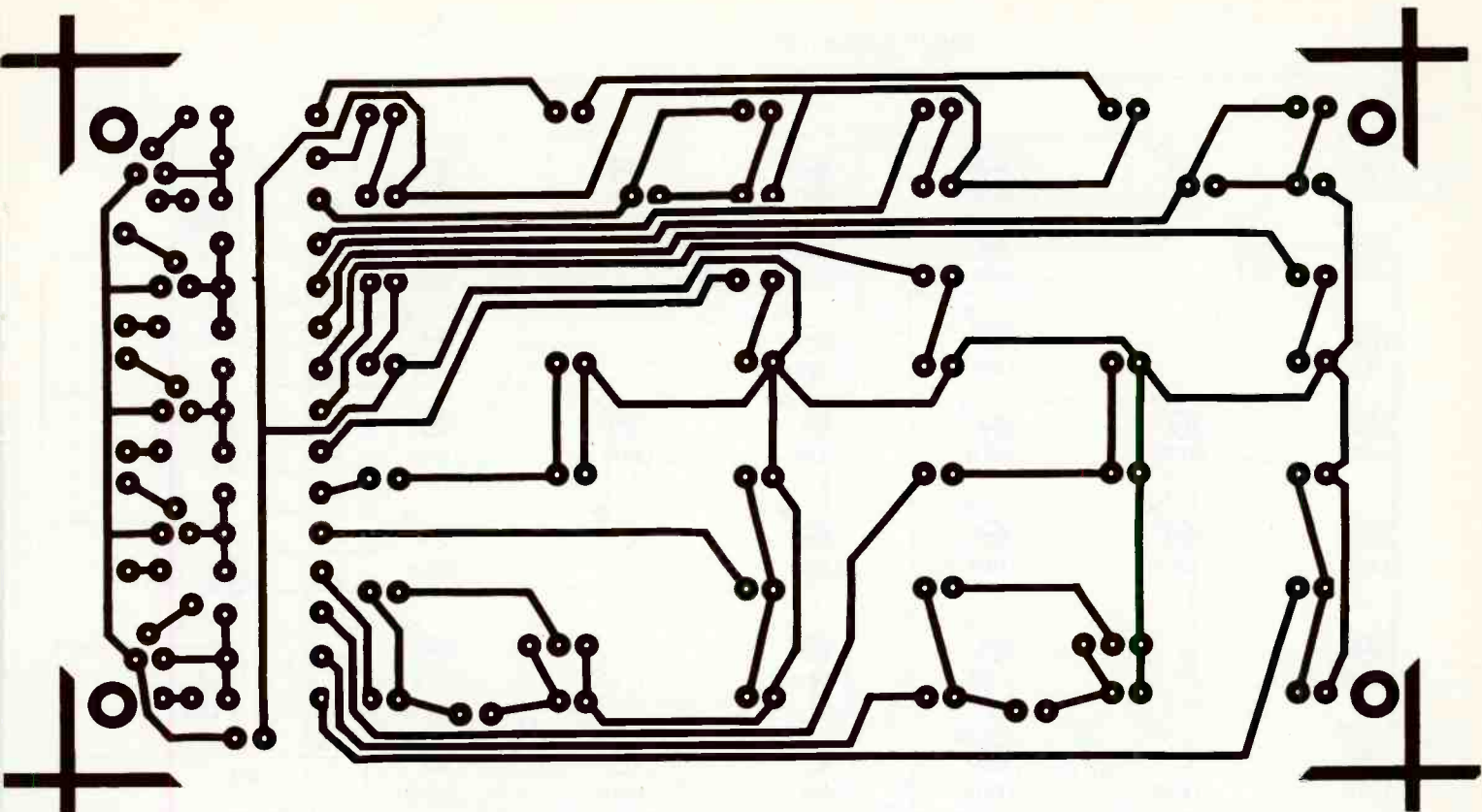

Fig. 4—The $7\frac{1}{8} \times 3\frac{3}{8}$ inch template of Solar-Powered House Number's display board is easily copied to a printed-circuit blank using the photo-resist method of printed-circuit preparation. But feel free to use the method that is easiest for you.

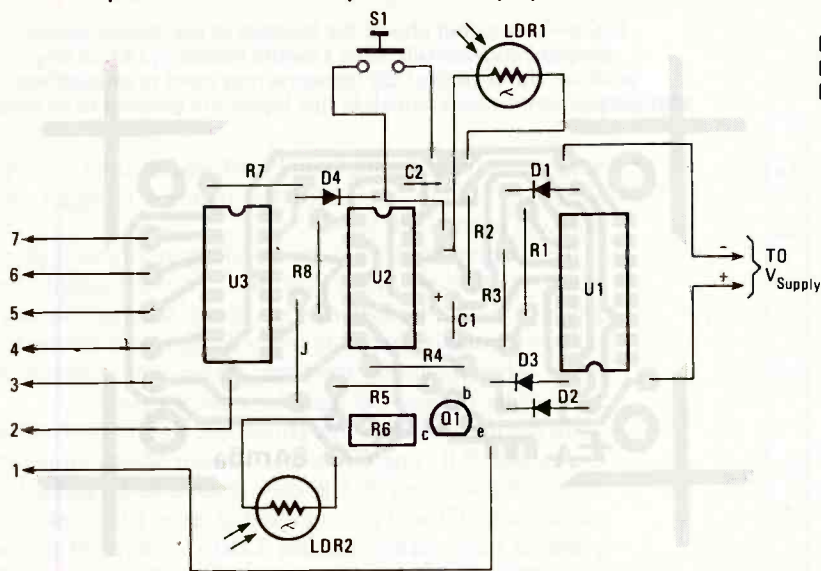

Fig. 5—The layout diagram of the project's control board leaves nothing to the imagination. Follow it and you should have no trouble.

ADDITIONAL PARTS AND MATERIALS

C1—2.2- μ F, bipolar electrolytic
 C2—0.001 ceramic disc
 S1—SPST normally-open pushbutton switch
 Printed-circuit materials, 12 solar cells (rated 0.45V/78-mA), 2 D-cell lead-acid batteries, silicone rubber sealant, scrap aluminum, enclosure, tinted plastic or bezel material, clear acrylic plastic, rainbow ribbon cable, hook-up wire, solder, hardware, etc.

PARTS LIST FOR SOLAR-POWERED HOUSE NUMBER

SEMICONDUCTORS

D1—D4—1N4148 small signal silicon diode
 LED1—LED19—High-efficiency/low-efficiency light-emitting diode (see text)
 LDR1, LDR2—ORP12 (resistance: dark, 10-megohm; light, 300-ohm) light-dependent resistor
 Q1—BC327 (or SK3200, ECG298) PNP silicon medium-power transistor
 Q2—Q6—BC338 (SK3854 or ECG293) NPN silicon medium-power transistor
 U1—4060 CMOS 14-stage, ripple-carry binary counter, integrated circuit
 U2—4093 quad, two-input NAND Schmitt trigger

U3—4017 decade counter/divider, integrated circuit

RESISTORS

(All resistors $\frac{1}{4}$ -watt, 5% fixed units unless otherwise noted.)
 R1—560,000-ohm
 R2—47,000-ohm
 R3—100,000-ohm
 R4, R7—1-megohm
 R5, R24—R28—4700-ohm
 R6—100,000-ohm trimmer potentiometer
 R8—10,000-ohm
 R9—R23—27-ohm

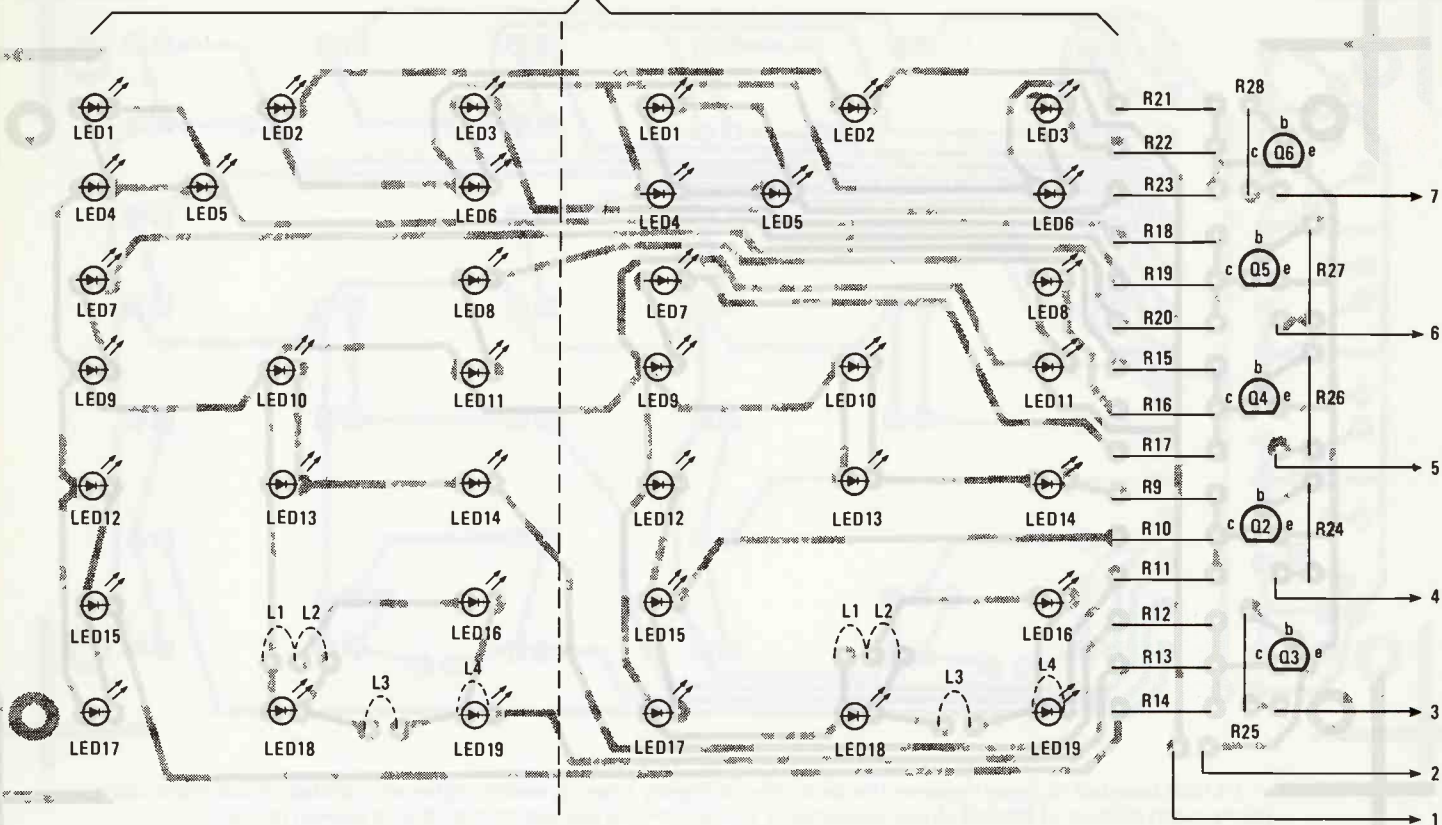

TABLE 1
DISPLAY ILLUMINATION GUIDE

Numeral	High-Efficiency LED's	Dummy LED's	L1	L2	L3	L4
1	3, 6, 8, 11, 14, 16, 19	13	•			
2	2, 4, 6, 11, 13, 15, 17, 18, 19	1, 10			•	
3	2, 4, 6, 8, 10, 14, 15, 16, 18	1, 11, 17		•		
4	2, 3, 5, 6, 7, 8, 9, 11, 12, 13, 14, 16, 19	1, 2*, 15	•			
5	1, 2, 3, 4, 7, 9, 10, 14, 15, 16, 18	2*, 6, 17		•		•
6	2, 5, 7, 9, 10, 12, 14, 15, 16, 18	1, 2*		•		•
7	1, 2, 3, 6, 8, 11, 14, 16, 19	2*, 4, 10	•			
8	2, 4, 6, 7, 8, 10, 12, 14, 15, 16, 18	1, 2*, 3, 9, 11		•		•
9	2, 3, 4, 6, 7, 8, 10, 11, 14, 16, 19	1, 2*, 9	•			
0	2, 4, 7, 6, 8, 9, 11, 14, 15, 16, 18	1, 2*, 3, 10		•		

*Install at second digit position.

Fig. 6—This layout shows the location of the display-board components. Consult Table 1 before installing LED at any position. Some of the LED locations may need to be outfitted with jumper connections, which in this layout are referred to as links (L).

adjacent to the printed-circuit board, and secured with epoxy adhesive. We also mounted the optional retrigger switch adjacent to the LDR's.

The battery holder can be manufactured from a piece of scrap aluminium. Make sure that it's of reasonably heavy gauge and that the batteries are firmly secured. Should the battery terminals happen to make contact with the holder, or some other mounting hardware, there will certainly be a spectacular display—at least for a few seconds.

To test the Solar-Powered House Number, temporarily alter the values of R1 and C1 so that a much shorter time period results. Substituting 56,000-ohm resistor for R1 and a .01-μF capacitor for C1 will give a period of about 10 seconds. Once power is connected, cover the LDR's or turn off the room light. The circuit should now trigger for the duration of the time interval, provided that the darkness continues. Turning the lights on should cancel the cycle immediately.

While the circuit is operating, try altering the level of light falling on LDR2. That should alter the brightness of the display. Calibration of the control, however, can only be carried out properly at the site where the unit is to be located.

Allow the circuit to go through one cycle, then press the retrigger switch. That should cause another cycle to commence. Resetting should occur after LDR1 is exposed to light, irrespective of whether the switch is fitted or not.

Provided that the circuit appears to be working properly, restore R1 and C1 to their normal values. The solar panel can now be connected, but make certain that the diode on the

(Continued on page 153)



By James H. Bran

With a feeder controller in your hunting gear, the game feeder loads itself

IT'S HUNTING SEASON ONCE AGAIN, AND LIKE A FLASH you grab your favorite hunting outfit and take off for the great outdoors. Crouched behind a clump of bushes, your outfit blending with the surrounding landscape, you wait for the game to arrive. Hours later, off in the distance, you hear scattered gun fire. Surely those hunters are having better luck than you are.

Then like a bolt from the blue, you realize that you've forgotten to set out your bait. Or perhaps some small critter—squirrel, or similar small beast—has been pilfering goodies from your feeder, so there's nothing left to attract the game. What ever! Off you go to your feeder just a few yards away, when just the prey you'd hoped to get in your sights shows on the scene. Startled by your presence, the game takes off for the high country.

And so your hunting excursion goes; each time you check the feeder, it's empty and as you attempt to restock it, the game gets a glimpse of you, sending it streaking into the underbrush. You quibble to yourself something to the effect that "I should have gone fishing."

The Game Feeder Controller provides an alternative to paying \$80 to \$100 for a similar factory-built timer equipped with a light-activated switch. Our device will turn on your feeder twice a day, once in the morning and again in the evening, and can be built for around \$20 or less (depending on how well your junkbox is stocked).

About The Circuit

The schematic diagram of the Game Feeder Controller is shown in Fig. 1. The circuit is built around an LM339 quad comparator, U1, which forms the basis of a Schmitt trigger, timer circuit, and a window comparator. One comparator within the LM339 (pins 1, 7, 6), plus LDR1, R4, R5, R6, and R8, is used as a Schmitt trigger. The timer circuit (which receives its input from the Schmitt trigger) consists of R9, R10, R11, R13.

The last two-fourths of U1 (pins 8, 9, 10, 11, 13, and 14) are wired as a window comparator. The two inputs to the window comparator are derived from the charge on capacitor C1—which is fed to pins 9 and 10 of U1. The other inputs are picked from two points along a voltage-divider network, consisting of R1, R2, and R3. Diode D1 is used as a blocking diode, forcing capacitor C1 to discharge through R10 and R13.

The window comparator looks for any voltage falling between one-third and two-thirds of the supply voltage. When the voltage falls between those two points, the output of the window comparator (pins 13/14) goes high. Transistors Q1, and Q2 are turned on, when the pins 13/14 junction goes high, energizing the relay, K1. The energized relay provides a DC path to ground, activating the motor, M1, which reloads the feeder. The timer circuit also provides immunity from triggering, due to lightning.

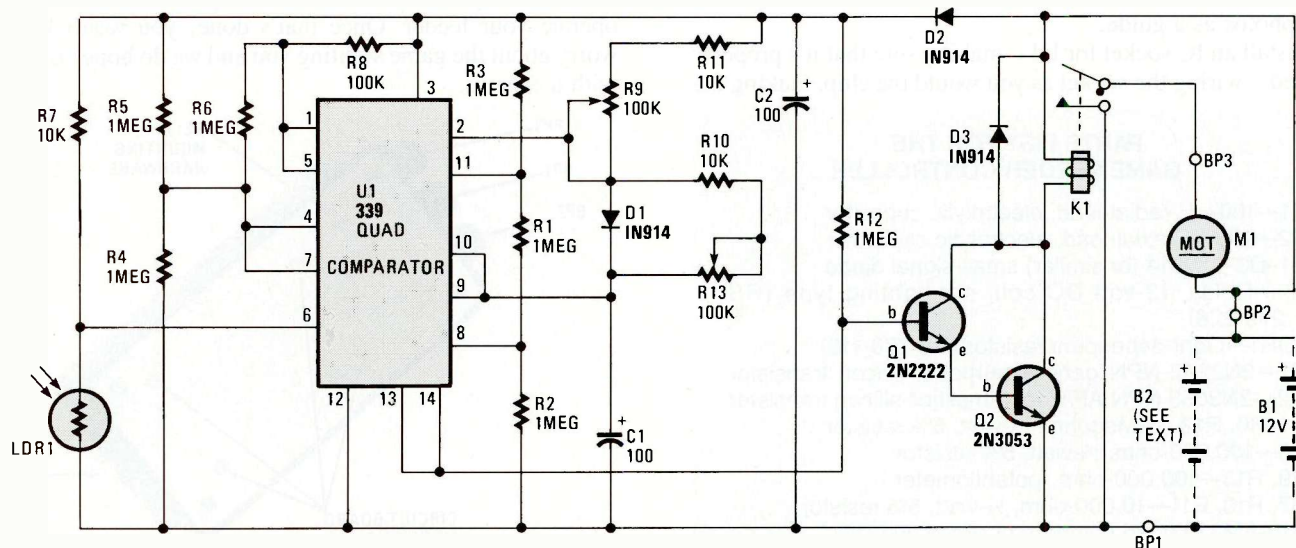
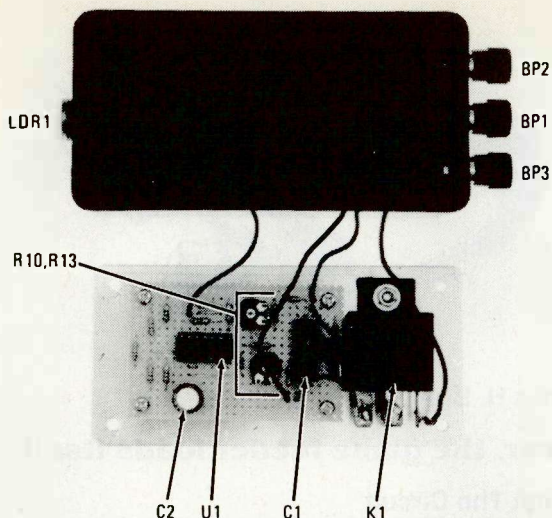

Fig. 1—The Game Feeder Controller circuit is built around an LM339 quad comparator, U1, which looks for any voltage falling between one-third and two-thirds of the supply voltage. When that occurs the output (pins 13/14) goes high, turning on Q1 and Q2, energizing K1, providing a path to ground to actuate the motor.



The author's prototype was built on a 2- $\frac{3}{4}$ by 1- $\frac{3}{4}$ inch piece of perfboard. The circuit-board/relay assembly was mounted to the top of the box. Four holes are drilled into the corners of the board and five into the cover (four for the board and one for the relay) to accommodate mounting hardware.

The on-time of relay K1 is determined by the charge cycle of C1, R11, and R9 or the discharge cycle of C1, R10, and R13. Changing the value of either a resistor or the capacitor, changes the timing cycle.

Construction

There is nothing critical about the circuit layout; therefore any construction technique can be used. If you wish, you can etch and drill your own printed-circuit board, using a layout of your own choosing. Or you might want to build the circuit on perfboard or experimenters board, using the appropriate interconnection technique—wirewrap, point-to-point wiring, etc. You might even consider laying out the circuit on a solderless breadboard. But, regardless of the construction method used, it's a good idea to use an IC socket for the comparator chip (U1).

In the author's case, the prototype was built on a 2 $\frac{3}{4}$ by 1 $\frac{3}{4}$ inch piece of bare (no copper) perfboard, using point-to-point wiring and cutoff resistor leads to accomplish the component interconnections on the underside of the board. If you decide to follow the lead of the author, use the layout in the photos as a guide.

Install an IC socket for U1—making sure that it's properly seated—wiring the socket as you would the chip, making the

PARTS LIST FOR THE GAME FEEDER CONTROLLER

- C1—100- μ F, radial-lead, electrolytic capacitor
- C2—100- μ F, axial-lead, electrolytic capacitor
- D1–D3—1N914 (or similar) small-signal diode
- K1—Relay, 12-volt DC coil, car-lighting type (RS 275-226)
- LDR1—Light-dependent resistor (RS 276-116)
- Q1—2N2222 NPN general-purpose, silicon transistor
- Q2—2N3053 NPN AF/video amplifier, silicon transistor
- R1–R6, R12—1-Megohm, $\frac{1}{4}$ -watt, 5% resistor
- R8—100,000-ohm, $\frac{1}{4}$ -watt, 5% resistor
- R9, R13—100,000-ohm, potentiometer
- R7, R10, R11—10,000-ohm, $\frac{1}{4}$ -watt, 5% resistor
- U1—LM339 quad comparator (RS 276-1712)
- Printed-circuit board or perfboard materials, IC Socket, PC-board standoffs, binding post, experimenter box, wire solder hardware, etc.

connections indicated in Fig. 1, and taking care to properly orient electrolytic capacitors C1, C2. When installing transistors Q1 and Q2, make sure that their biasing is correct before soldering their leads to the other wires.

Once the circuit is completely assembled, it can be housed in any plastic or metal enclosure that's large enough to accommodate the circuit-board assembly and power relay K1 (the experimenter box listed in the Parts List, for example). The circuit-board/relay assembly is mounted to the top of the enclosure, on spacers to prevent shorting. Drill holes into the board, and cover to accommodate the mounting hardware.

Next, drill five holes into the enclosure itself—two in the front panel (through which LDR1 is connected to the board) and three in the back panel to accommodate binding posts BP1–BP3 (two going to the power source and the last one serving as one of the motor connections)—for the off-board components. When mounting LDR1, run a thin bead of quick-set epoxy cement or silicone adhesive around the LDR outside the box to anchor it in place.

Using standard No. 18 hookup wire, connect the circuit board to the off-board components. First cut four 4- to 6-inch lengths of wire, stripping away about a quarter of an inch of insulation. Tightly twist the bare ends and tin them to prevent *bird caging*. Connect and solder to the appropriate points.

Calibration and Use

To calibrate the Game Feeder Controller, connect a 12-volt automobile battery to the circuit via BP1 and BP2. Now, connect the motor, M1, to BP3 (which is attached to the K1 contact) and to the positive post of the battery. Adjust R9 and R13 to their mid positions, and hold your hand over LDR1 until the motor starts and stops running. Then, remove your hand and the motor should cycle through another run. Now, this time, put your hand back over LDR1 and measure the amount of time that the motor runs.

On most feeders, the optimum run-time is four seconds. You can make changes in run-time by adjusting potentiometers R9 and R13. Adjust R9 for triggering by decreasing light, and R13, for increasing light. When choosing your battery, be sure it can handle the amount of current required by the motor. If the battery amperage isn't sufficiently large, the relay will drop out.

Well that just about does it, except for connecting it to operate your feeder. Once that's done, you won't have to worry about the game sighting you and we do hope you shoot with a camera. ■

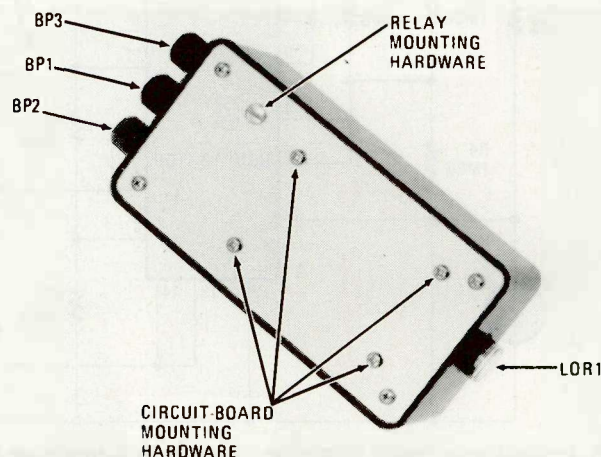

In the base of the project box five holes are drilled—two in one side, through which LDR1 is connected to the board, and three in the other to accommodate the binding posts, BP1–BP3.

THE TIME CAPSUL— UNMASK THOSE PHANTOM CAPACITORS

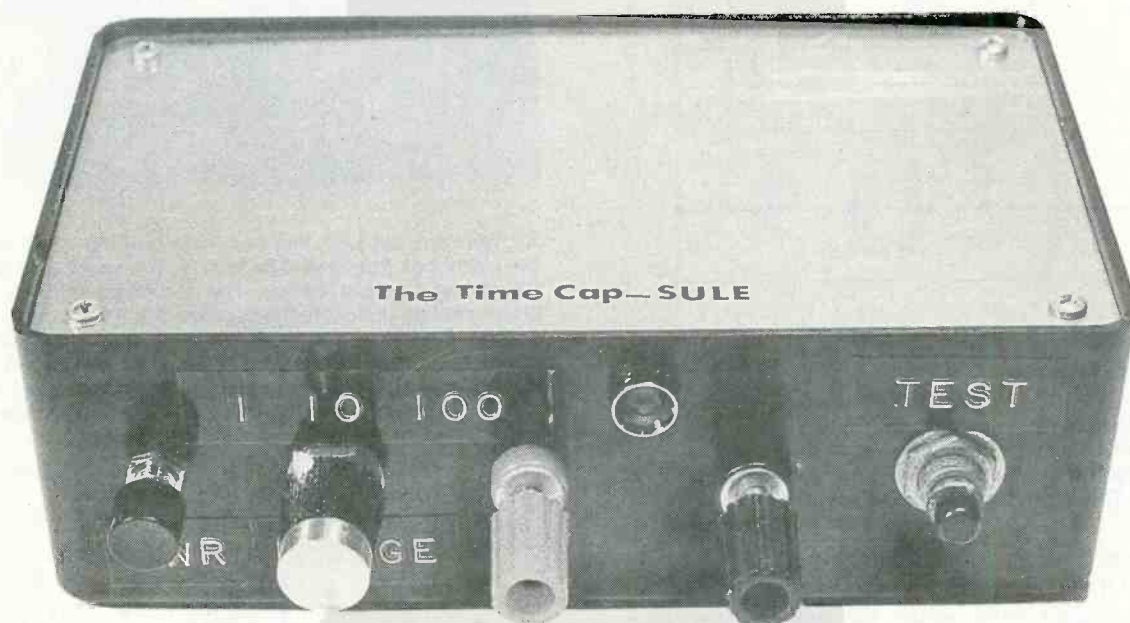

If your junk-box over-floweth, you most likely don't know the value of many of your capacitors. Well, now you can easily sort the large values.

By Frank I. Gilpin

□ WHETHER YOUR JUNK-BOX IS THAT, OR IS A COLLECTION OF neatly labeled boxes or jars containing clearly-identified parts, you can still put the Time CapSUL to good use on your workbench. This is not the Jules Verne model. The name is a point-stretching acronym meaning, "Timing Capacitance for Sorting Unidentified Large Capacitors".

There are many commercially-made capacitor checkers and some which can be built by the experimenter, but none so accurate, simple, or as much fun to use as the Time CapSUL. You can come up with this precision instrument in less than two evenings, and probably under \$20. It will test 1 to 10,000 microfarads with great accuracy and, if you wish, keep any family musician on the beat.

How's it Work?

The Time CapSUL is composed of two simple building-block circuits. The first (see Fig. 1) is a timing circuit using the familiar 555 IC operated as an astable oscillator (U1). Its cycling is determined by capacitor C4 and timing resistors R6, R7, and R8. When the voltage across C4 reaches about

two thirds of V_{CC} , it discharges rapidly through R6 and pin 7 of U1 until it reaches one third of V_{CC} before the cycle repeats. The frequency rate of the cycle can be varied by adjusting R8. The output pulse at pin three drives a small speaker through coupling capacitor C5. Since much of the circuitry for that section is contained in the IC itself, the unit's timing will be little affected by changes in the supply voltage.

Incidentally, the unit will deliver from about 40 to more than 220 beats-per-minute using the parts values shown in the schematic. That makes it a great candidate for a musician's metronome if you replace the miniature trimmer potentiometer R8 with a large, panel-mounted potentiometer. Use a stopwatch or sweep second hand to calibrate the panel according to the beats-per-minute table shown. Don't forget to carefully mark the 60 bpm spot on the dial so that the unit can still be used as a capacitor checker. The size or impedance of the speaker used is irrelevant, so pick one that best fits the case selected for the project.

The second section of the unit is also built around a 555 timer chip (U2) used in a monostable configuration (see Fig.

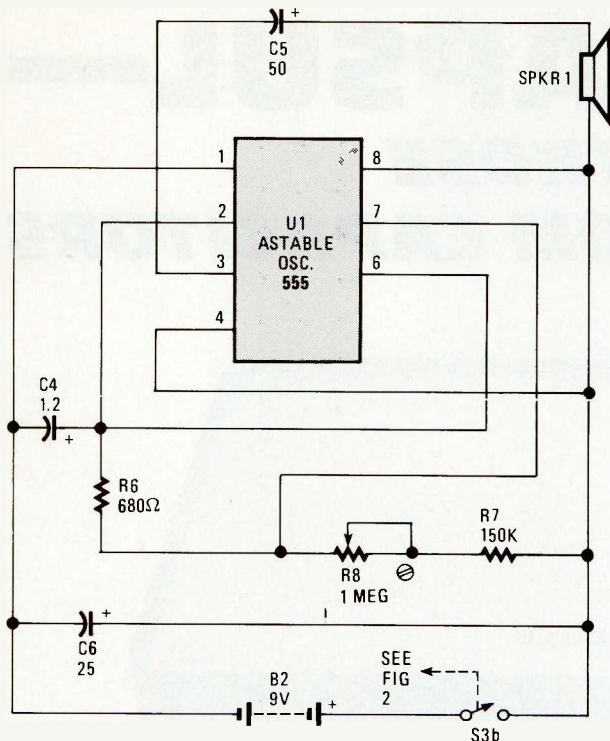

Fig. 1—Astable operation means that the 555 will trigger itself into operation after a specified low time and remain high for another specified time, and the cycle begins again. This output is feed to the speaker.

2). That section, however, uses the pulse at pin 3 of U2 to light an LED (LED1) through current-limiting resistor R2. The length of the output pulse equals the timing capacitance multiplied by the timing resistance. The timing resistance between pins 7 and 8 in that section is provided by switch-selected fixed resistors instead of a variable resistor. The capacitor under test becomes part of the timing circuit and determines the on-time of LED1. Range switch S1 will give you 1 μ F-per-second at setting A, 10 μ F-per-second at B, and 100 μ F-per second at C.

So few parts are needed, that the original unit was wired on a perf board instead of the more time-consuming and expensive printed-circuit board. You may use any technique you prefer. The layout is not overly critical, but keep the leads between the chips and other components as short as possible. It is also a good idea to use sockets for U1 and U2 to eliminate any possibility of heat damage during soldering. The timing section and the LED-indicator section are independent of each other and have no direct connections. They do share the same power switch, but use separate sections of it. If you cannot find the correct values for R3, R4, and R5, use two or more resistors in series to total the values required.

The only calibration necessary is to adjust R8 with the power on until, measured against a stopwatch or sweep

TABLE 1—DIAL CALIBRATION

Beats Per Minute	Tempo
40-60	Largo
60-66	Larghetto
66-76	Adagio
76-108	Andante
108-120	Moderato
120-168	Allegro
168-200	Presto
200-208	Prestissimo

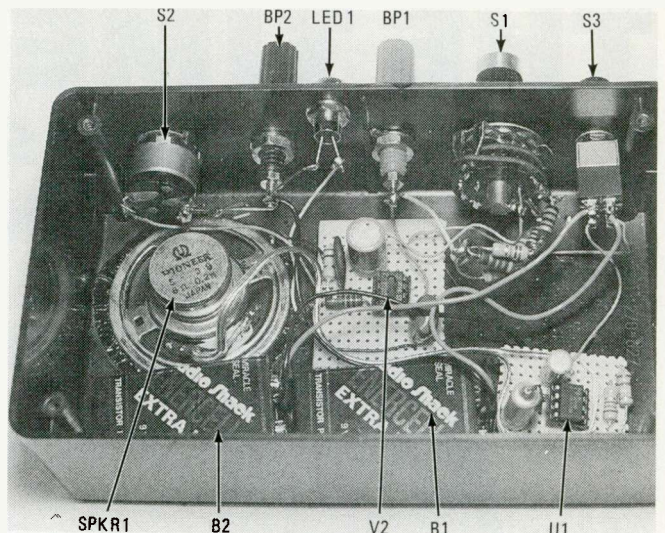

All switches, the LED, and multi-way binding posts mount on the utility-box front panel as shown. The speaker is epoxy-glued over a hole in the box. The perf board with the LED driver section is next to the speaker, and the speaker-driving IC section is to the far right. R3, R4, and R5 mount directly on range switch S1. The batteries and circuit boards are held securely in place with cabinet-sized foam rubber squeezed when the box cover is screwed down.

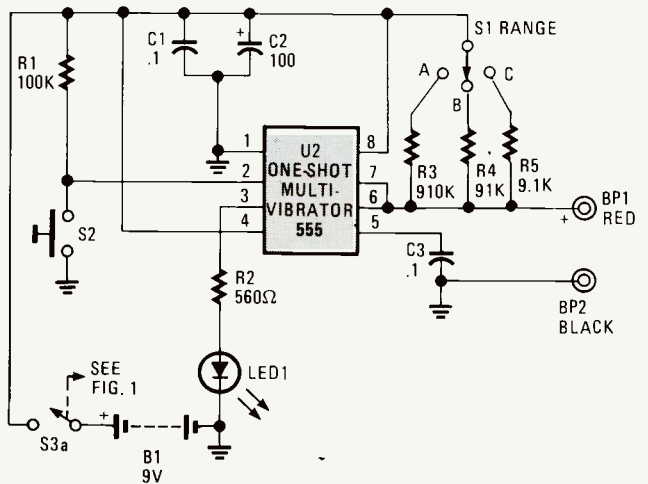

Fig. 2—Monostable operation allows the 555 to be triggered by input (a logic low) pulse, of any duration no matter how short, and it will output a high for a period of time determined by its resistor-capacitor network.

second hand, the speaker clicks at 60 beats-per-minute exactly. Get this as close as possible.

In the author's prototype, solid hookup wire was used to make the connections between the two perf boards and the panel-mounted components S1, S2, S3, J1, J2, and LED1. Flexible, stranded wire was used for the battery connectors. The small speaker, salvaged from an old pocket radio, was epoxy glued over a hole cut through the bottom of the enclosure. An enclosure-sized piece of two-inch-thick foam rubber was used under the cover to keep circuit boards and batteries firmly in place after the cover was screwed down.

Power-Up

To operate the assembled unit, turn on the power, set the range switch to the highest range ($\times 100$) and connect the

(Continued on page 152)

Forget the big bucks. You can assemble most of an IBM PC/XT from what other people throw away



BUILD THE POOR MAN'S IBM PC/XT

EVEN IF YOU HAVE ABSOLUTELY NO USE FOR A COMPUTER at this time, your future depends on your having one. Whether it's to prepare a better report for school, to learn word processing because most entry-level office jobs require the skill, to become adept at Lotus because many employers now require a knowledge of spread-sheets, or even if you're simply running a small business from the kitchen table that's outgrowing your shoebox record-storage system. Each day that you are without a personal computer you fall a bit behind of the rest of the crowd.

Now we all know that personal computers, particularly an IBM PC or one of its clones, doesn't come cheap, but you can probably assemble one yourself for just a fraction of a clone's retail price because much of the hardware you'll need might be tucked away at the back of some closet: stuff that you can get for free, or at little cost!

For example, a friend might have an original IBM disc controller left over after upgrading to a multi-function disc controller, while flea markets are a good place to find old style (but new for you) serial and parallel adapters. Maybe your office has converted to the new-style keyboard and the boss has a closet full of older IBM keyboards he'd like to throw out but he's too cheap. And then there are local dealers who might be "stuck" with a batch of monitors with old-fashioned cabinets that can't be easily sold because everyone wants a monitor in a cabinet with high-tech styling. Or maybe you, yourself, upgraded your original IBM for your mail-order business and you've got a drawer full of adapters that can be used to make up a separate computer so the kids can stop using your bit-blaster for their homework. And if you can't get the stuff free or at flea-market prices, there are mail-order dealers with warehouses full of "surplus" hardware; "surplus" being a euphemism for "no one wants it, so sell it cheap."

The photo at the top of this article gives you some idea of

what's possible. The computer itself has no name because it's built into a \$35 IBM-clone cabinet. The keyboard is an original IBM PC that no one wanted because it didn't have a separate numeric keypad or status lights for the CAPS LOCK, NUM LOCK, and SCROLL LOCK keys. The monitor is a razor-sharp NEC that was originally priced near \$200. It was purchased for less than \$50 from one of America's largest and most famous retailers because people just wouldn't buy such an old-fashioned cabinet. And the two disk drives on the front of the computer were originally used in an upgrade for a Radio Shack Color Computer.

OK, got the picture? We're going to show you the tricks of assembling your own IBM-clone.

The Motherboard

There are three things that you must buy, no matter what else you do. They are the cabinet, the motherboard, and a power supply. For those we recommend any reliable mail order dealer such as JDR, or any local dealer—which is preferable—who will meet JDR's price. There are two kinds of IBM-type computer cabinets. One is a copy of the original, having a chassis that slides out of a sleeve: a troublesome design if you're into changing adapters, experimenting, or anything else involving playing with the guts of the machine. The other kind has a flip-up cover; it's the type shown in the photos. That's the one we recommend, and it should cost you no more than \$35 to \$40.

The motherboard is the computer itself. Most, but not all, IBM-type motherboards sold by mail-order houses are clones of the IBM PC/XT. Some are PC/AT clones, others are some kind of unknown quantity that resemble an IBM PC/XT—but not necessarily. However, do not confuse them with a "turbo" PC/XT clone motherboard. The "turbos" are XT's that can be software or hardware switched to run about 30% faster than a conventional XT. The reason they must be switched is

This computer cabinet with a flip-up cover comes complete with all hardware, including the speaker and mounting brackets for the disk drives. Price is between \$35 and \$40.

that some software won't run at the higher speed. If you want to keep costs at rock-bottom stick to the straight PC/XT clone. They're now available for about \$100 and are the least trouble when it comes to accessories and software. Keep in mind that the true PC/XT clone, such as the JDR shown in the photos, has eight slots, not five or six, for plug-in adapter cards. (You will probably need at least six or seven slots if you're using "freebie" or flea-market hardware.)

You will also need something known as a BIOS: a ROM or an EPROM containing the input/output system for the computer. They simply plug into one of the empty sockets on the motherboard. Normally, they sell for about \$20-\$30, but some dealers will throw it in for free with the motherboard. (That's how we got ours.)

Then there's the power supply. The way some magazines tell it, no power supply is ever large enough. Nonsense. There's only so much that can fit into the cabinet. A 135-watt supply that usually sells for less than \$70 will handle two floppies, one or two hard disk drives, a 3.5-inch drive, and just about anything else you'll put in the computer. An IBM-type supply will have two power connectors for the motherboard and four (yes four) connectors for disk drives. (The original IBM PC power supply had only two disk drive connectors. Make certain yours has four.) Also, make certain it is a true IBM PC/XT type as shown in the photograph, with the power switch on the side and two power connectors arranged horizontally on the rear. That is the configuration for the standard PC/XT-type low-cost cabinet. Everything, from the fan intake opening to the mounting screws will fit together if you get an exact PC/XT-type power supply. Anything else won't fit the cabinet directly.

Cabinet Assembly

If your dealer is at all typical, the cabinet will come with an assortment of parts and not a word about how to put it together. Here are a few tips. There is probably a plastic



bracket for the supplied speaker. The speaker's magnet snaps into the bracket and there will be matching mounting holes for the bracket somewhere inside the left front of the cabinet. There will also be an assortment of metal plates for mounting and installing the disk drives. Don't expect to find a use for most of them. And keep in mind that two screws are all that are needed to support a drive.

If you have never seen the inside of an IBM computer don't do anything until you see one, and study how everything is arranged. If necessary, make a sketch or take some Polaroid pictures. That is necessary because while the inside of your clone will look like an IBM, much of it is mounted differently. You must know approximately what goes where in order to figure out what hardware to discard. (The clone-type cabinets are made for a variety of "dealer-assembled" hardware configurations, so a lot of extra hardware is supplied.)

Be extremely careful with the screws. They are metric, not ASA (American). Except for the disk driver, do not try to substitute ASA screws. They are a problem we'll get to later because the wrong mounting screw can destroy a disk drive. (No fooling; it's the famed "metric error"—meaning no metric-to-American conversion really works).

The cabinet assembly will be easier if you remove the large bracket that holds the disk drives; it's usually held by only four or six screws. While you're at it, remove the disk drive "dummies"—the four half-height plastic strips that fill the mounting spaces for the disk drives. Don't force them, they



The BIOS is usually, but not always, supplied as an extra-cost option. You simply plug it into the appropriate socket on the motherboard. This one comes free with the JDR motherboard.

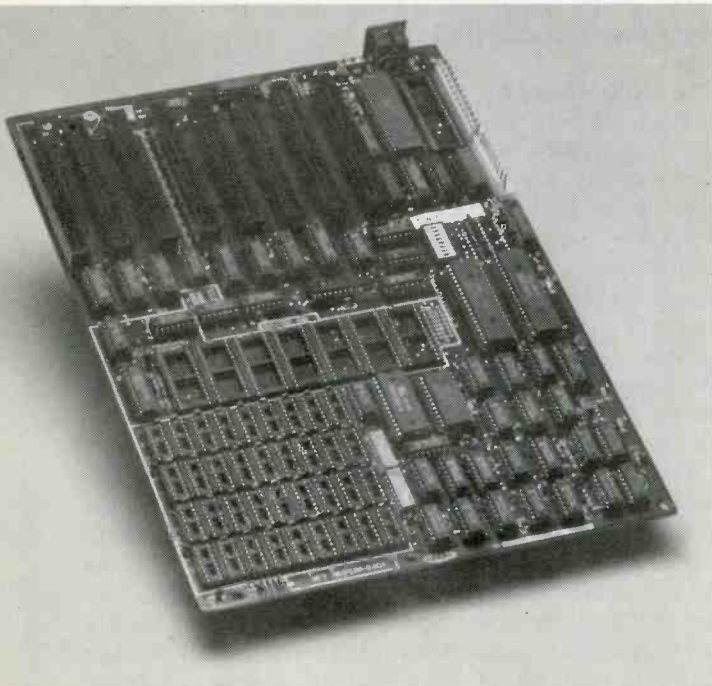

This PC/XT clone motherboard from JDR accepts 640K of RAM and has eight slots. Do not get a board with less than eight slots.

should pop free (you might need to use them later to cover unused openings). After the disk-drive bracket is removed, install the speaker and its shield. The shield is usually the bracket for the adapter-card support rails.

Prepare the Motherboard

The first step is to install the BIOS ROM or EPROM in what is usually socket A7. For that step you'll probably get more detailed instructions with the motherboard than you can possibly imagine. Then install the memory IC's. The motherboard has four empty rows of nine sockets each. Each row can accept 64K RAM sets (nine 4164 IC's) for a total of 256K, or two rows of 256K RAM sets (nine 41256's per row) and two rows of 64K. The RAM capacity is programmed by simply moving a plug on the motherboard; instructions for the plug are supplied with the board. Don't try to save a few dollars on RAM. The minimum acceptable memory in terms of new software is 512K, so we suggest you initially install two rows of 256K RAM's for a total of 512K. As shown in the photograph, that will leave two rows unused. You can install two rows of 64K RAM's at a later time, or you can fill up the full 640K now. The extra two rows of memory will cost slightly under \$20 additional.

The next step is to install the motherboard in the base of the cabinet. Use all standoffs, spacers, and insulators exactly as described in the documentation supplied with the motherboard. Leave all screws slightly loose until every mounting screw is installed. Then push the board to the front of the cabinet and tighten the hardware. The forward push is important because it provides the very slight clearance needed at the rear so the plug-in adapter mounting brackets will fit without damaging the motherboard.

Next, install the power supply making certain the power switch fits the cutout on the right side of the cabinet, and then reinstall the disk drive mounting bracket. Now for the moment of truth. The disk-drive bracket is meant to hold one or two full-height drives; up to four half-heights; or one or two half-height floppies, and one full or two half-height hard disk drives. If you believe you have no intention of ever using a hard-disk drive use full-height drives. They have a better reliability factor than the half-heights, and more important, no one wants them, so they are usually very inexpensive. Many users replace their two full-height drives with two half-heights so they have an empty compartment for a hard disk. If you can use a full-height drive you can buy one of the "discard" ones new for less than \$50, or even pick one up "almost new" for as little as \$35.

Mounting the Drives

Any double-sided 5-1/4-in. floppy drive advertised as IBM-compatible can be used. That includes drives used by Radio Shack, Zenith, and others. The two half-heights shown in the photos are manufactured by Teac, and were originally used by someone who had upgraded a \$100 Radio Shack Color Computer. Normally, however, you will get the lowest price on full-height disk drives. If you use full-heights, simply secure them with two screws passed through the bottom of the cabinet. If you use half-heights, install the bottom one first, using two mounting screws through the left hand bracket. Then attach the right-hand bracket to the drive. Then install the top drive.

The two rows of empty sockets on the motherboard are for rows of 64K RAM's. The two rows immediately to the right are filled with 256K RAM's, which provide a total of 512K memory.

Extra Care

But be extra careful. Although the mounting holes on the bottom of foreign drives might be ASA threaded, the sides often have two sets of holes: one metric, the other ASA. Unfortunately, in many drives the ASA holes are directly opposite the drives' circuit board and the mounting screw simply cracks the edge of the board along with a trace or two. It is an outright stupid design, and you must take extreme care that side-mounting screws do not damage the drive. If you use ASA (type 6-32) screws, make certain they are no longer than 1/4-inch. (By the way, you do not have the screw-damage problem with full-height, made-in-the-U.S. drives.)

A Working Computer

All you need now to get the computer up-and-running is a disk-drive controller and a monitor adapter. You will find that an IBM-type controller can now be purchased new for well under \$30 (\$10 at flea markets), or you can use a relatively low-cost, multi-function controller that also provides a parallel printer port, one or two serial ports, a game (joy-stick) port, and perhaps a clock. The multi-function board is an outstanding value because you get so much for well under \$100. But, and it's a *big BUT*, if you have any intention whatsoever of upgrading the computer in the future, get the cheap IBM-type controller even though the multi-function controller is a much better dollar value. The reason is that the IBM-controller has a connector on the back that was originally intended for two more floppy drives, so it is almost never used. However, the IBM 3.5-inch disk drive's cable plugs directly into that connector, as does one of the least expensive and most convenient tape backup machines (the Irwin). Since 3.5-inch disks will most likely be the standard size by next year, everything will be a lot easier if you have a controller with the external connector.

In addition to the disk controller, you'll need a monitor driver: what IBM calls an "adapter." There are three type of monitors available that work off two basic kinds of adapters. If you're looking to cut costs to rock-bottom, go for a Color/Graphics Adapter and a composite monochrome monitor. The Color/Graphic Adapter, usually called a CGA, allows you to use most word-processing software and all color graphics software. True, the composite monochrome monitor will display everything in shades of green or amber, but that beats not seeing anything at all. You can get an IBM-clone CGA card for about \$30 mail order, even less at flea markets;

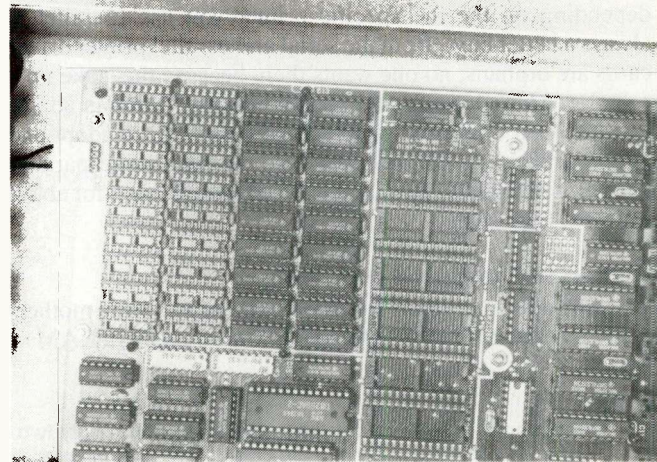

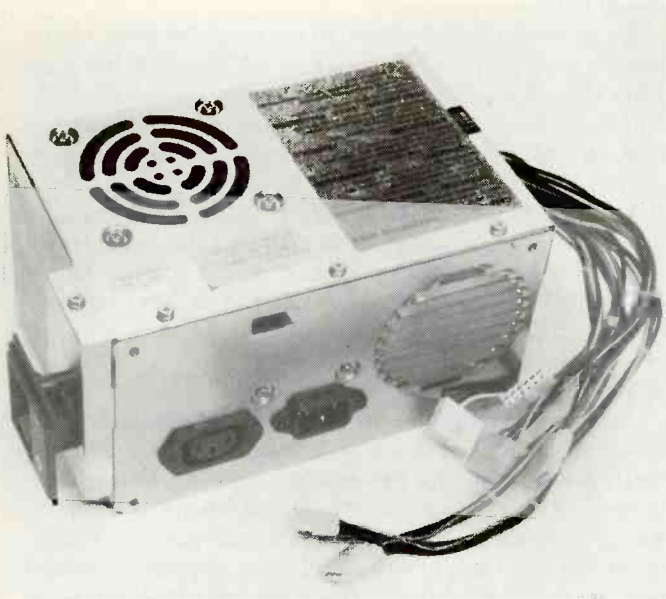

No, this is not an IBM power supply, it just looks like one. Notice that it has a total of six power connectors: two for the motherboard and four for disk drives. Do not get a supply with only two disk-drive power connectors.

or maybe there's one stuck away in an office or school closet, or maybe a friend has one he's not using because usually the CGA card becomes obsolete when someone upgrades to extended color graphics. (Again, try to pick up someone's Color/Graphic Adapter cast off.)

The Operating System

Use any version of PC/MS-DOS version 2.0 or higher that's available. If it's IBM's PC-DOS you won't have BASIC because PC-DOS looks for IBM's BASIC in ROM—which your clone won't have. If you have MS-DOS it will have GWBASIC, which emulates IBM's ROM BASIC in RAM. If you never intend to write or run a BASIC program, it won't make any difference whether or not BASIC is available to you. If you have to buy a version of DOS, get MS-DOS 3.1 or 3.2 (3.2 if you think you'll add 3.5-inch disk drives at a later time for added versatility).

Up and Running

With the cabinet, motherboard, 512K of RAM, two disk drives, a disk controller, and the monitor adapter, you've assembled a complete IBM-clone. If you want to add a printer at a later time, you'll need either a serial or parallel adapter, depending on the the specific printer you use (parallel is always a better buy). Both the serial and parallel printer driver cards are orphans; no one wants them because they take up a full slot. Many have been replaced by multi-function adapters. But your computer has plenty of free slots, so adopt one of the orphans. Last time I looked, an IBM-type parallel adapter was about \$15, while the serial adapter went for about \$25, not bad is it?

Setting the Switches

Finally, there's a small 8-section DIP switch on the motherboard that must be set to correspond to the amount of RAM in

Here's the budget-clone ready to go. Note that only two of the slots are used: for the disk controller and adapter.



Assembly will be easier if you install the motherboard and disk drives first. The power supply will fit in the large open space at the right. Notice that one complete disk-drive position is open. It can be used later for one or two hard-disk units.

the computer, the type of monitor, the number of disk drives, and whether a math-coprocessor (for extra high-speed math operations) has been installed. There's no reason to waste time going into it because every clone motherboard we've seen comes with notably clear and extensive instructions on how to set the DIP switch.

One last and final word on assembling your own clone. Try to get as much as you can locally, so that if anything is defective you can get a quick exchange. We have had nothing but success with mail-order dealers when it comes to expediting the original order, but getting a replacement for a defective component happens at a snail's pace. Oh, you get the part without any problem. It's just that replacements seem to go at the end of the shipping list. We have waited as long as six weeks to get a defective part replaced. (Remember, even the best shipper, UPS, takes at least six days from coast to coast.) So if you can, use local dealers. ■

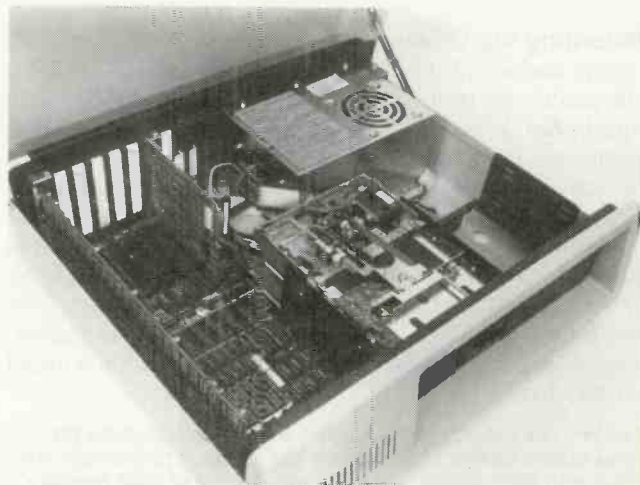

Build a SMOKE SECURITY ALARM

WITH THE CRIME RATE GOING OUT OF CONTROL, security alarms—running the gamut from simple buzzers for use on doors or windows to expensive whole-house systems that automatically dial a subscriber service—are a necessity today. And the cost of an alarm system that includes a few *bells and whistles* can be astronomical. But if you're among those who take pleasure in doing things for yourself, read on and see how you can build and install this home-brew system and pocket the savings.

This low-cost, battery-operated security alarm features unusually low standby power consumption of a few microwatts. The circuit drives either a piezo buzzer or operates in conjunction with a smoke alarm equipped with a normally-open electrical test button. The tripped alarm sounds for about eight minutes and may be altered for continuous alarm. And get this: the security alarm includes door exit and entrance time delays, a feature found only on better-grade systems.

Circuit Operation

Figure 1 shows the circuit for use with a smoke alarm. Figure 2 shows the modifications to the circuit for use with a piezo transducer or buzzer. Timer U1 is a CMOS version of the bipolar 555 timer. Capacitor C1 and resistor R1 determine the timing interval. When switch S1 is set to the ARM position, the circuit is on standby awaiting closure of remote switch S4 located on a door or window. (Additional window and door switches may be added in parallel with S4 as needed to cover the entire house.) When switch S4 is closed, capacitor C2 delivers a trigger pulse to the gate terminal (G) of the silicon-controlled rectifier (SCR1). The SCR switches from off to on and connects the ground terminal (Pin 1) of U1 to battery minus.

U1 is triggered when pin 2 is pulled low (below $\frac{1}{3} V_{cc}$). When SCR1 fires, capacitor C3 briefly holds pin 2 of U1 low, triggering U1. That causes the output of U1 at pin 3 to go high, which then turns on U2 (a 4N30 optoisolator/coupler),

Let your smoke detector
double as a security alarm

By Adolph Mangieri

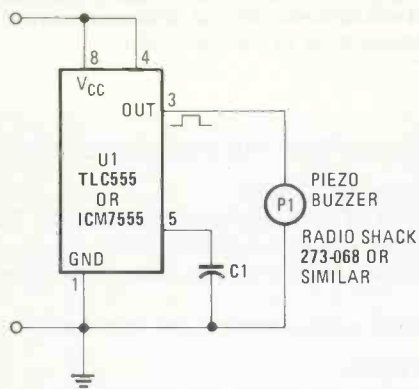

Fig. 2—If you decide to build the security circuit but do not intend to incorporate it into a smoke detector, follow this diagram to connect a piezo buzzer as the output device.

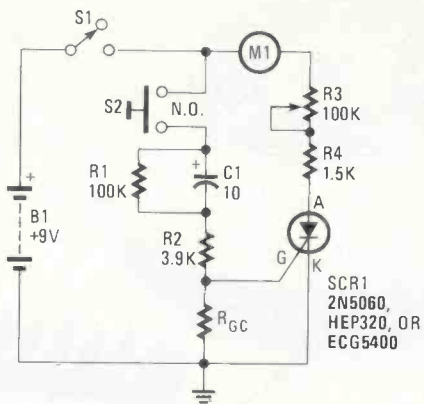

Fig. 3—This circuit can be used to check SCR holding current for various values of gate-to-cathode resistor.

Fig. 1—The author chose to build the security portion of his project—which consists of relatively few components—on perfboard. However, if you prefer printed-circuit construction, by all means feel free to go that route.

circuit, temporarily replace R1 with a 100,000-ohm resistor, set S1 to the DISARM position, and connect a DC milliammeter set to the 10-milliamper range in series with the battery. Next connect a jumper wire from SCR1's anode to its cathode. Set S1 ARM. Timer U1 should trigger immediately and M1 should indicate 1 to 2-milliamperes. When timing ceases, current drops to several hundred microamperes.

Set switch S1 to DISARM and remove the jumper across SCR1. Set S1 to ARM. Meter M1 should indicate zero. Close S4 to initiate timing. If SCR1 does not fire, use a smaller value resistor for R6. After U1 times out, the meter should indicate near zero. If not, SCR1 has not switched off because the holding current is too low. Decrease R7 to increase the holding current of SCR1.

Using a 470,000-ohm resistor for R1, verify that the time interval is about five to ten minutes. Using clip leads, connect the circuit to the smoke-alarm test button and verify the

operation of U2. If the alarm sounds with S1 set to DISARM, the transistors in U2 are too leaky. Try reducing resistor R5. If everything seems OK, install the circuit in the smoke alarm and make connections to the smoke alarm battery and push-to-test button.

The Earli-Gard smoke detector draws about 17-milliamperes when it sounds and the security-alarm circuit draws 1.2 milliamperes. On standby, the battery drain is one-half microampere or less (too low to measure). The circuit operates with supply voltages of 5 to 15 volts. Depending on supply voltage, re-size resistor R4 to obtain about one-milliampere of current into pin 1 of U2.

To provide a switch-selectable continuous or eight-minute sounding, install a single-pole switch in series with R1 and V_{cc}. Open the switch for continuous sounding. Use a 9-volt DC, wall-transformer power unit in place of the 9-volt battery for continuous alarm. For an invalid's bedside panic alarm,

Remove the cover from the smoke alarm to verify that the test button is a normally-open switch. Caution! Do not tamper with the smoke sensor. The smoke sensor (which is shielded by a slotted metal can) contains a small amount of low-level radioactive material.

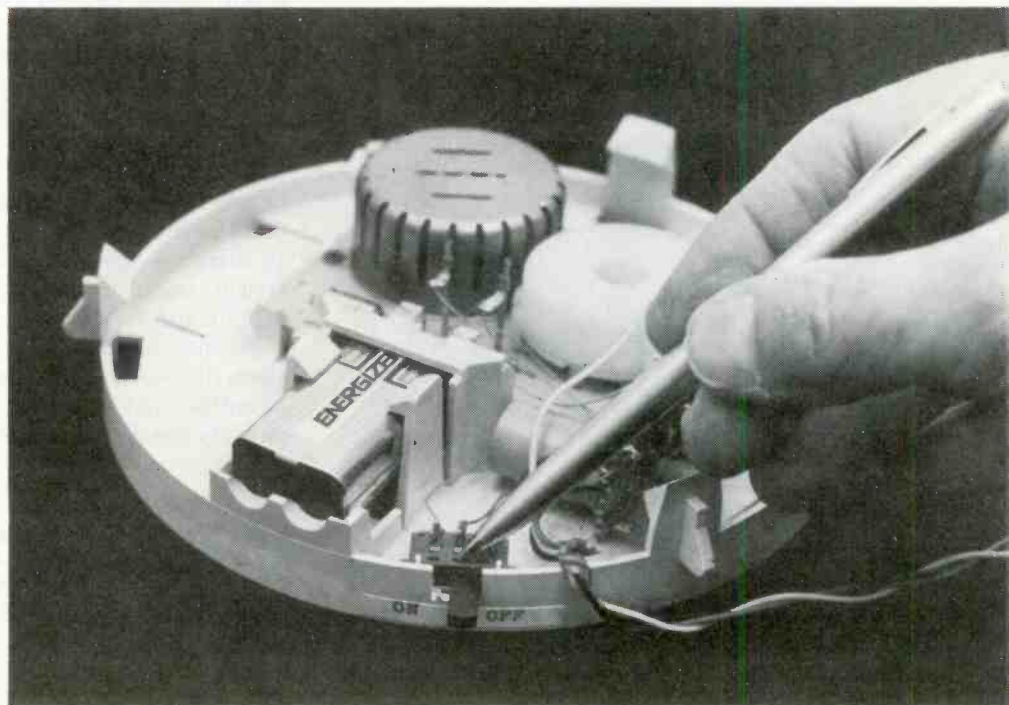

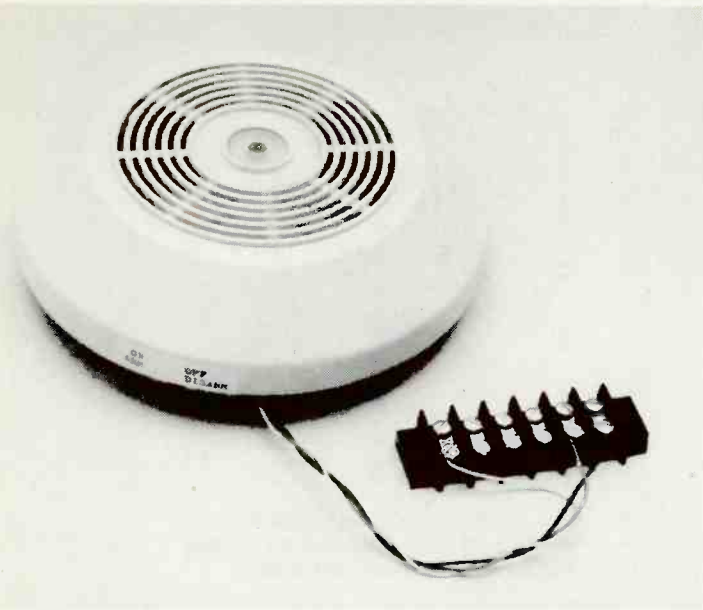

install S2 on the case of the alarm.

To check the exit time delay, press S3 and close S4 15-seconds later. If the alarm sounds, capacitor C2 is probably leaky. Throw S1 to DISARM and back to ARM. Repeat that test, now waiting 25-seconds before closing S4. The prototype alarm afforded about 45-seconds to exit and reclose a door. Install switch S3 on the smoke alarm or near the door.

If you are not using a smoke alarm, omit U2 and resistors R4 and R5. Connect a DC-operated piezo-electric buzzer from pin 3 to pin 1 of U1 as shown in Fig. 2. Install the components in a small plastic case.

Application

Remote switch S4 closes when an intruder opens a door or window. Use magnetic reed switches, which open when the magnet is engaged, such as Radio Shack part number 49-512. Normally-open computer keyboard switches and lever-actuated microswitches are easily installed for momentary closure when a door or window is opened. Additional switches are connected in parallel with S4 at terminals A and B in Fig.

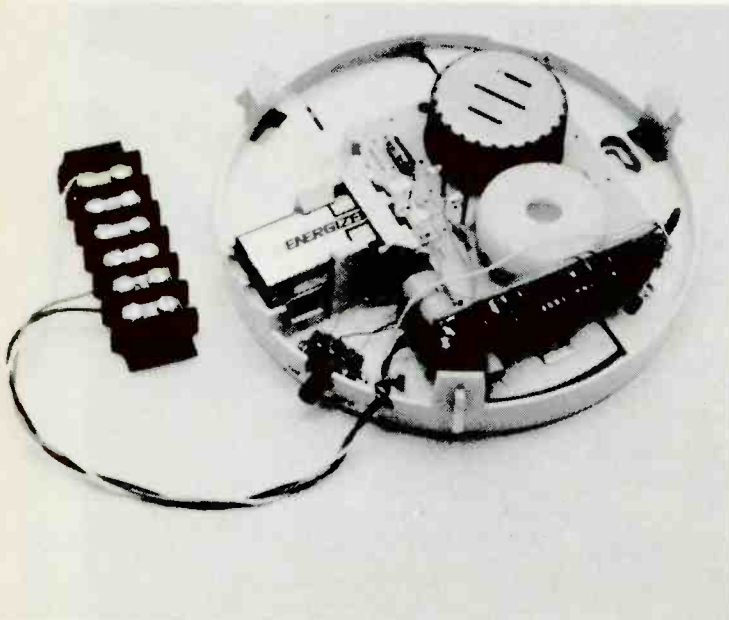

Once the project is completed, the best way to handle the connections between the Smoke/Security Alarm is to tie all points that will connect with the remote sensors to an ordinary barrier strip as the author did.

PARTS LIST FOR THE SMOKE/SECURITY ALARM

SEMICONDUCTORS

SCR1—HEP320, 2N5060, ECG5400, TCG5400, SK3950, silicon-controlled rectifier
 U1—TLC555 or ICM7555 oscillator/timer, integrated circuit
 U2—4N30 optoisolator/coupler, integrated circuit

RESISTORS

(All resistors are 1/4-watt, 5% fixed units.)
 R1—470,000-ohm
 R2—100,000-ohm
 R3—270,000-ohm
 R4—5600-ohm
 R5—1-Megohm
 R6—3900-ohm
 R7—1800-ohm
 R8, R9—10-Megohm

CAPACITORS

C1—470- μ F, 16-WVDC, electrolytic
 C2—6.8- μ F, 35-WVDC, Tantalum
 C3—10- μ F, 16-WVDC, electrolytic
 C4, C5—0.05- μ F, ceramic disc

ADDITIONAL PARTS AND MATERIALS

S1—Single-pole, double-throw toggle switch
 S2, S3—Normally-open pushbutton switch
 S4—Magnetic reed switch (see text)
 Smoke alarm, perfboard or printed-circuit materials, flea clips, enclosure, IC sockets, wire, solder, etc.

The following items are available from Circuit Specialist, PO Box 3047, Scottsdale, AZ 85257: 2N5060 (SCR) at \$0.60; 4N30 (optoisolator/coupler) at \$1.50; ICM7555 (oscillator/timer) at \$1.20, plus \$2.00 shipping and handling. Please allow 6 to 8 weeks for delivery.

1. The alarm is defeated if any of several paralleled switches is left closed. Use test button switch S2 to check for that condition and quickly reset and ARM the alarm.

When you enter a door and trip the alarm, close the door, flip S1 to DISARM and back to ARM for continued protection. If you prefer a door entry delay, install a normally-open key-operated switch outside of the door and connect it in parallel with the exit delay switch (S3) between terminal A and ground in Fig. 1. To enter the door, close and open the switch using the key and enter and close the door within 45 seconds. To disarm a door or window without disarming the entire system, install a single-pole single-throw switch in series with the trip switch.

Mounted at about eye level on a wall, the smoke/security alarm still provides early warning smoke detection. However, do not use a modified smoke alarm in place of an unmodified, properly installed smoke alarm. ■

If you look closely, you'll notice that instead of using two separate IC sockets for U1's 8-pin package and U2's 6-pin package, that the author mounted both chips in a single 16-pin DIP socket, separated by the leftover pin positions.



THE DIRTY LITTLE FM SNOOPER

By Ricky Shea

This snooper used as a fun gadget can bring many hours of enjoyment to the listeners and listeners!

NO, IT'S NOT JUST FOR SECRET AGENTS AND *BOUDOIR* bandits! The *Dirty Little FM Snooper* was designed for the amateur broadcaster, for weak-voiced stage singers, as a baby-sitter replacement, and countless other people with ethical applications. But, let's be honest: Wouldn't you like to know what the team is saying about you in the locker room? How's this party stopper: Broadcasting the gals comments in the powder room? What, the Devil you say? Exactly!

The Dirty Little FM Snooper is an FM transmitter that consists of a simple condenser microphone, which is used to modulate the output of a small, one-stage, FM transmitter. The transmitter radiates a continuous wave whose frequency is altered in sympathy with the sound waves striking the microphone. You need only an ordinary FM-broadcast receiver (88-108 MHz tuning range) to detect its output carrier. A pocket FM receiver with an earphone plug will do the job.

When you tune across the FM dial in your town, you will find one or more wide gaps where there are no broadcast signals. Your Dirty Little FM Snooper should be tuned to one of those gaps in the band so that you will pick up its minuscule signal loud and clear, and you won't cause any annoying interference to your neighbors. Don't worry too much about your neighbors. The power output of the transmitter is very low as specified by the FCC, so the Dirty Little FM Snooper's output should not get too far. If you do irritate the big guy next door, just tune to another gap in the band. If he's a beer drinker, tune to the lower educational portion of the dial—88-90 MHz.

Voice to FM Carrier

The Dirty Little FM Snooper's circuit is basically an RF

oscillator that operates at around 100 MHz. Refer to Fig. 1. The most important parts of the oscillator are transistor Q1 and the tuned circuit, which embraces the inductor L1 and the variable capacitor C5.

When the 9-volt transistor-radio battery, B1, is connected, a brief surge of current flows from the collector to the emitter of Q1, causing an alternating current (shock oscillation in the resonant LC circuit) to flow back and forth between L1 and C5. An oscillating voltage, therefore, appears at the junction of L1 and C5. The frequency of the oscillation depends on the

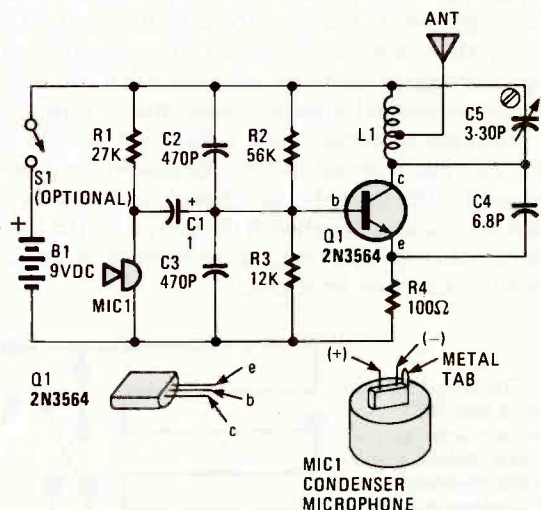

Fig. 1—The Dirty Little FM Snooper circuit is a one-stage, FM transmitter. The condenser microphone, MIC1, couples audio to transistor Q1 whose internal junction capacitance provides a variable capacitance to the LC-tuned circuit, thereby frequency modulating the output carrier.

values of L1 and C5, so that varying the value of C5 tunes the oscillations to the exact frequency desired.

The oscillating current in L1 and C1 would rapidly decay to nothing, but for the fact that the oscillating voltage is fed back via C4 to the emitter of Q1. That action makes the base-emitter current of transistor Q1 vary at the oscillation (resonant) frequency. That causes the emitter-collector current to vary at the same frequency, keeping the current flowing in the tuned circuit and continuing the oscillations. Some of the energy in the oscillating electric and magnetic fields of the tuned circuit is radiated as radio waves, partially by the circuit itself and mainly by the antenna.

Modulation Made Easy

But why do sound waves arriving at the microphone vary the frequency of those waves? They can do that because the frequency of the oscillations depends on the total capacitance in the oscillator circuit. Although tuning capacitor C5 accounts for the major part of the tuning capacitance, other parts of the circuit also make minor contributions. In particular, the capacitance between the base and the collector of Q1 has a small, but noticeable, effect on the oscillation frequency. That capacitance, which is known as the *junction capacitance*, is not a fixed value, but instead varies when the voltage on the base of the transistor varies. Sound waves striking the microphone induce a voltage that varies in time with the sound and that voltage is applied via C1 to the base of Q1, thereby frequency modulating the transmitter.

Solderman of the Board

It's unequivocally vital to use the printed-circuit board detailed in Fig. 2, because one of the indispensable components, the RF-inductor L1, is actually part of the board itself. You can make your own printed-circuit board from the template we supply or purchase one—details a bit later.

Begin by soldering the resistors onto the board, referring to Fig. 3 for their locations. Next, mount the fixed capacitors (C1, C2, C3, and C4), taking care that C1, the electrolytic or tantalum capacitor, is inserted with the correct polarity.

That leaves only two components to be mounted on the printed-circuit board: The variable capacitor, C5, shouldn't present any problems, because it can be installed without fear of polarity problems. However, there are three holes for two terminals; That's a problem you can solve quickly. Look at the flip (foil) side of the board and notice that two holes are electrically connected together. Once-upon-a-time C5 had three mounting terminals, now it has two! Be absolutely positive that one terminal of C5 connects to the lonesome solder pad on the printed-circuit board, and that the other terminal of C5 connects to one of the duo pads. The holes for C5's terminals may be a bit tight, so ream them out gently; only a millimeter may be required.

Fig. 2—The template for the Dirty Little FM Snooper's printed-circuit board also includes one part in the resonant circuit—tuning coil L1. The template is shown here same size.

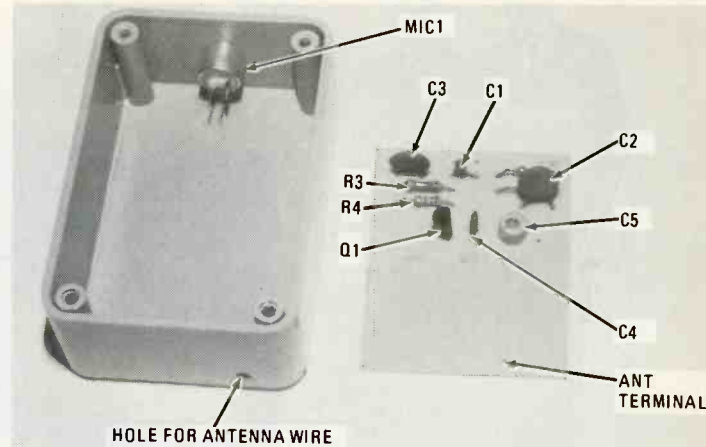
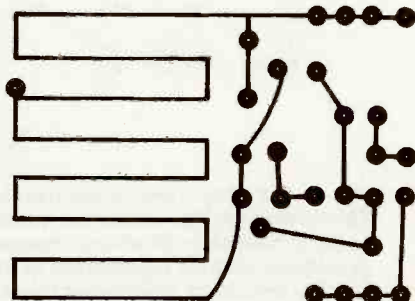

The printed-circuit board is shown here completely wired, except for battery and microphone connections. The time required to assemble the components onto the board was only 20 minutes. You will spend much more time preparing the plastic box and installing the microphone and printed-circuit board.

The other component, transistor Q1, must be oriented correctly before it is soldered to the printed-circuit board. Refer to the transistor terminal-identification drawing in Fig. 1. Seat the transistor in the board and solder in place.

Stop now and carefully inspect the board at this time. All the leads should be clipped close to the board, solder connections should be shiny and bright, and the parts in their correct locations as indicated in Fig. 3.

The Antenna

Since the Dirty Little FM Snooper is intended to be a short-range transmitter, only a small antenna is necessary. Excellent results were obtained with an antenna about 5-inches long, made from a piece of stiff wire soldered onto the printed-circuit board at point A on Fig. 3. Longer antennas will increase the range considerably, with the best range being achieved with an antenna about 24-inches long. However, apart from being unwieldy, such an efficient antenna is unwise—if the Dirty Little FM Snooper transmission is too powerful it will begin to interfere with other listeners of the FM band and thus it may actually corrupt the purpose for which it is being used.

Once all the parts are mounted on the PC board, you can connect the battery-clip leads now (for B1), and the microphone (MIC1) connections will follow.

You may decide to add a SPST, on/off switch (S1 in Fig. 1) in series with one leg of the battery's leads. That can be done any time after the project is completed.

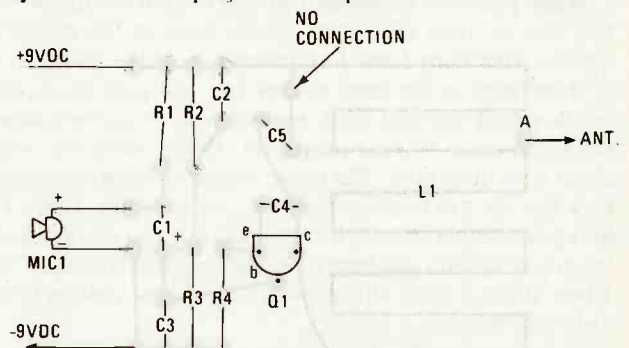

Fig. 3—The board layout for the Dirty Little FM Snooper is hassle free. Solder all—the parts to the board, then connect the external leads. Use the battery clip as a power switch.

Boxing the Snooper

If you are going to house the wired Dirty Little FM Snooper in a box, do not use a metal one. The box used by the author is a small experimenters box made of plastic and it came with an aluminum cover. Only two holes were drilled in the box; one for the condenser microphone, MIC1, and the other hole for the antenna wire to protrude. The hole for the microphone was hand reamed to an exact size so that the microphone slipped in easily and held in place. A drop of clear nail polish holds it in place. Do not force-fit the delicate microphone into the hole—it can be damaged.

Solder two uninsulated, solid, copper wires to the microphone terminals on the printed-circuit board and clip the length to one inch. Slip the board into the box as shown in the photo. With the microphone in place, the two added wires will be along side the terminals of the microphone. The wire that connects to ground (negative terminal of B1) connects to the metal tab and negative terminal of MIC1. The other wire connects to the positive terminal of MIC1. Refer to Figs. 1 and 3 for additional details.

Slip a ½-inch to 1-inch square of ⅛-inch foam that has self-adhesive *stick'um* on both surfaces under the printed-circuit board, and press down gently, securing the board to the box. Attach the battery clip to B1 and try to fit it into the box sideways—it just doesn't make it. Snip off the plastic vinyl covering on the clip and now the battery will fit snugly without need for any mounting arrangement.

Setting Up

Tune your Dirty Little FM Snooper to a point on the FM dial where there are no broadcast stations near by. With the radio microphone fairly close to your receiver and turned on, use a small non-metallic screwdriver to adjust the variable capacitor, C5. At some point you should hear a terrible "howl" through the receiver. The Dirty Little FM Snooper is

PARTS LIST FOR THE DIRTY LITTLE FM SNOOPER

CAPACITORS

- C1—1-μF, 16-WVDC, electrolytic (or tantalum)
- C2, C3—470-pF, ceramic
- C4—6-pF, ceramic
- C5—1-30-pF, trimmer

RESISTORS

- (All resistors are ½-watt, 5% units)
- R1—27,000-ohm
 - R2—56,000-ohm
 - R3—12,000-ohm
 - R4—100-ohm

ADDITIONAL PARTS AND MATERIALS

- B1—9-volt, transistor-radio battery
- L1—Center-tapped coil (part of printed-circuit board)
- MIC1—Condenser microphone
- Q1—2N3564 transistor
- S1—SPST slide switch (optional)
- Printed-circuit board, 3-¼ × 2½ × 1⅛-in., experimenters box (Radio Shack 270-230), battery-connector clip, clear nail polish, foam spacer, solid hookup wire, stiff antenna wire, solder, etc.

The printed-circuit board, parts mounted on it, and the microphone are available in kit form for \$9.50 plus \$2.00 for shipping and handling costs from Imtronics Industries, Inc., 11930 31st Court N., St. Petersburg, FL 33702. Please allow 6-8 weeks for delivery.

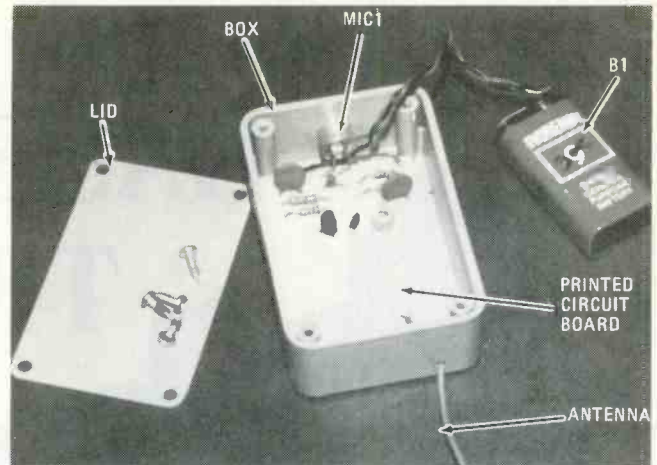

The completed Dirty Little FM Snooper is ready to be buttoned up and put to respectable use. Never use the project in an application that you would not want used in a similar way on yourself, your friends, or family. Be certain that everyone will laugh when what you have done has been revealed to them.

now transmitting on the same frequency that your FM receiver is tuned to. That condition sets up acoustic feedback, because the Dirty Little FM Snooper is too close to the FM receiver's loudspeaker. Turn the receiver off, leave C5 set in the same position, and move the receiver away from the Dirty Little FM Snooper. Now turn your FM receiver on again and get a friend to speak at the microphone. For complete clarity, you may need to alter the tuning of your receiver slightly.

If you do not own a non-metallic screwdriver, fabricate one from an old solid plastic stirrer used to make bar drinks. You can carve or file a blade that will turn the rotor of C1.

Power Consumption

The Dirty Little FM Snooper consumes power all the time it is on, whether there is any sound being transmitted or not, so batteries don't last too long. You can expect a 9-volt, transistor-radio battery to last about ten hours. Use a bigger battery or a 9-volt power supply (wall-plug module power supply) if you want continuous use for longer periods. The battery clip is used as an on-off switch.

Radio FM microphones like the Dirty Little FM Snooper are used extensively by stage performers and by professional eavesdroppers, but they do have more mundane uses as well. The Dirty Little FM Snooper can be used for any kind of remote monitoring of sounds. For example, you can use one to hear your phone or doorbell ringing when you're sitting out in the backyard, or to make sure you don't miss a word of your favorite TV program while you're in the kitchen. It makes for an excellent baby alarm, too, because the Dirty Little FM Snooper can go anywhere that baby goes. Just don't forget to bring an FM receiver with you. ■

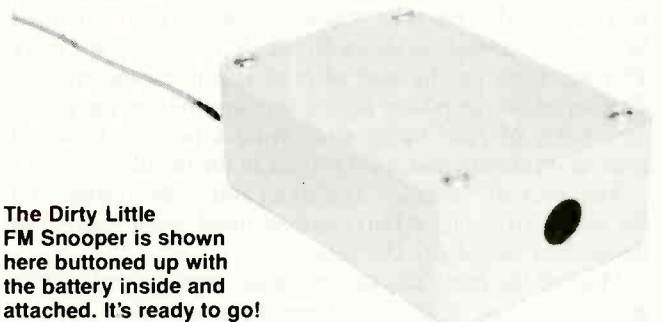

The Dirty Little FM Snooper is shown here buttoned up with the battery inside and attached. It's ready to go!

GASEOUS-STATE TRANSMITTER

Here's how Dad did it! Now you can do it in an hour's time!

By Larry Lisle, K9KZT

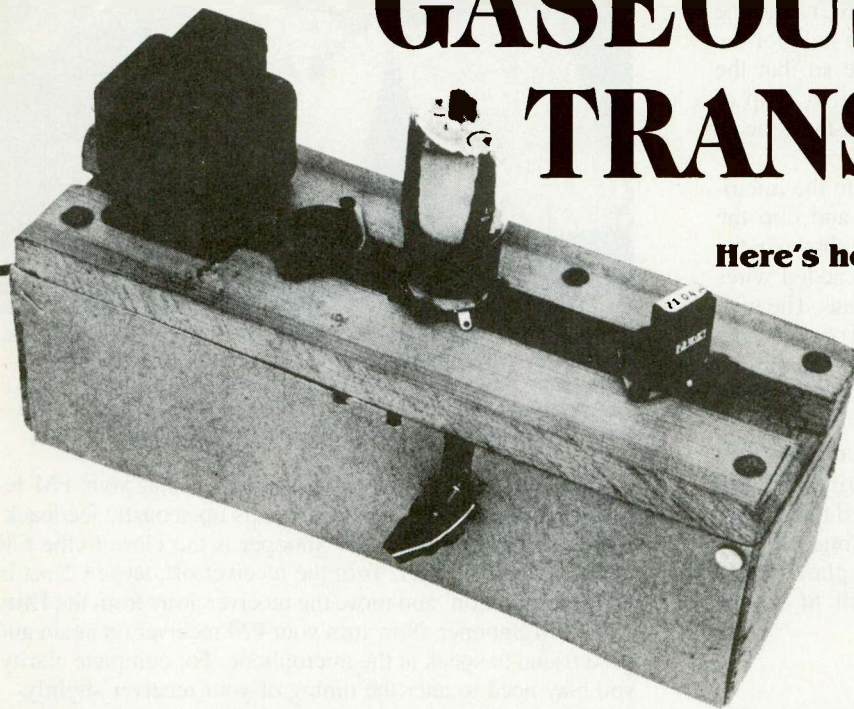

WHO SAYS A HAM TRANSMITTER HAS TO BE COMPLICATED, or expensive, or use hard-to-get parts! Here's a little RF rig that will really do the job on the 40-meter band, and won't strain your Visa Card or project-building abilities. I call it the *Gaseous-State Transmitter* for far out reasons. First, it's not solid state! Second, there's always some gas in any vacuum made on Earth. Third, and last reason, the electron flow in a vacuum tube is based on the gas equations of Poisson. If you didn't look at the photographs in this article, and still can't guess what it's all about, let me tell you. The Gaseous State Transmitter uses a vacuum tube—the famous 6L6 type. And, if you need a fourth reason, every so often I tire of solid-state gadgets and long for the old days.

I built the the Gaseous-state Transmitter shown in the photographs in an hour's time and have had many enjoyable amateur contacts in 42 states using Morse code—good, solid contacts too!

Designer's Thoughts

Although I've never seen a transmitter exactly like the Gaseous-state Transmitter, the device isn't exactly on the cutting edge of modern, electronic technology. The RF portion is housed in the time tested 6L6/GC vacuum tube used in a simple, crystal-oscillator circuit. It loafs along at a mere 25-watts input for the sake of good keying characteristics. The super-simple power supply was inspired by the *Economy Forty* of Fred Sutter who wrote a popular series of articles on simple transmitters back in the thirties.

The wooden "chassis" is also a child of the thirties and the cardboard panel (skirt) came to mind when looking at the back of an old AC-DC radio.

Most of the parts can be scrounged from an old 1950's or '60's TV set, or purchased new for about thirty dollars.

Availability of parts was a major consideration in designing the transmitter and all parts, but the variable capacitor and crystals, should be easy to get. The variable capacitor and crystals can be obtained at hamfests or by mail from advertisements in the back of the various ham magazines.

Some builders may question whether television interference (TVI) may be a problem without shielding and that is a valid consideration if you live in an apartment house centered in a weak, TV-signal area for instance. In that case I suggest you build the rig on an aluminum chassis and use the usual shielding and filtering procedure. For most people though, with the low frequency and low power used by this transmitter, TVI won't be a problem—it wasn't for me.

In case you're wondering whether a single capacitor can do an adequate job of filtering the power supply—it can. A 5 percent ripple is considered adequately low for the high-voltage supply of a CW transmitter—the Gaseous-state Transmitter has less than 1-percent ripple. But, if you want to over build, go ahead.

Finally, how about *chirp* or *drift*. There isn't any in this transmitter. Those problems were taken care of by running only 25-watts input, keeping the screen voltage low, omitting the usual capacitor between the bottom of the plate coil and ground, and not using *chirpy* crystals.

In the old days hams used to run 100-watts or more input to the earlier versions of the 6L6 vacuum tube—and used a hammer to keep the tubes from jumping out of the sockets—25-watts only tickles the 6L6/GC. A few crystals you may find will chirp. The solution's simple—don't use them! Surplus crystals are still cheap, especially when buying several at a time, so don't use those few that won't give you a signal of which you can be proud.

The modern, plated crystals don't work as well as the older FT-243 style, so use the latter (they're cheaper too!)

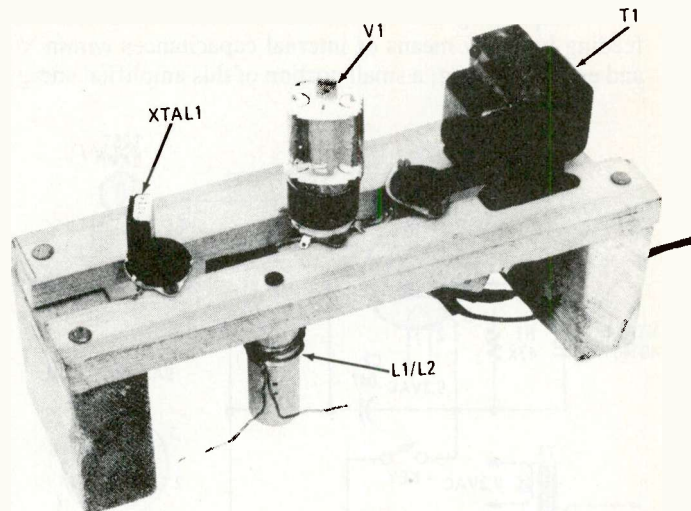
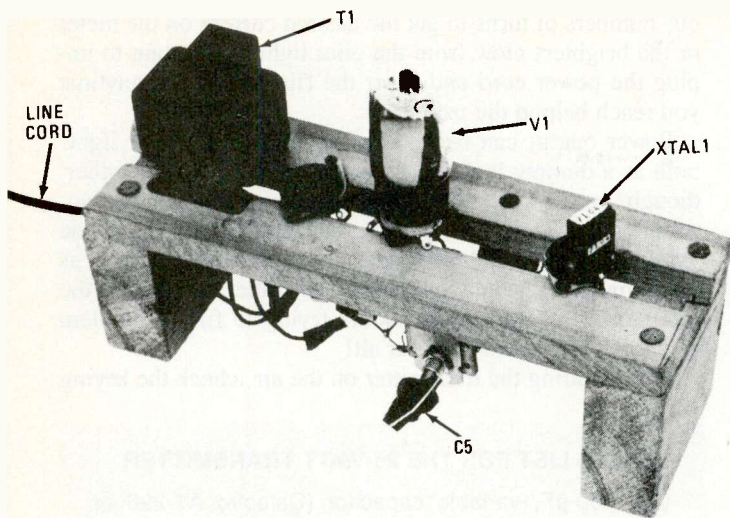

Here's the 25-watt Gaseous-state Transmitter you can build in an hour. It uses a 6L6/GC vacuum tube, a wooden chassis with cardboard side panels, and a power transformer scrounged from an old TV set to put a solid CW signal on the 40-meter band. Front and back views are shown. It's a project transmitter that even a beginner can build!

Shop Work Begins

The photographs show how the rig is put together. I used three octal sockets: One for the 6L6/GC vacuum tube, one for the RF crystal, and one as a set of tie points for the power supply.

Glue a 12-inch long furring strip on two 2 × 4 wood legs and hold in place with a nail at each end. Using the octal sockets as a spacing guide, glue and nail the second furring strip in place. You'll probably find it easier to partially wire the sockets before mounting them on the chassis and then connect things together.

Fabricate a small aluminum bracket to hold the variable capacitor, C1, by its shaft hardware. Secure the bracket to the wood chassis using small wood screws. Fasten the variable capacitor to the bracket.

The tank coil, L1, has 15 turns of #22 enameled wire wound on a short piece of a one-inch wooden dowel which is glued at one of the one-inch furring strips—do not nail the dowel rod in place. Use a brass screw—the smallest one that will do the job. The wood dowel has a permeability equal to air and the coil is, in fact, an open-air coil. A near-by iron nail or screw would upset the coils rating and function. If you can't find enameled wire, solid hook-up wire will work with slightly lessened efficiency. One good supply of enameled wire is inside a defective or surplus power transformer. Try to use a wire as close to the #22 size as possible.

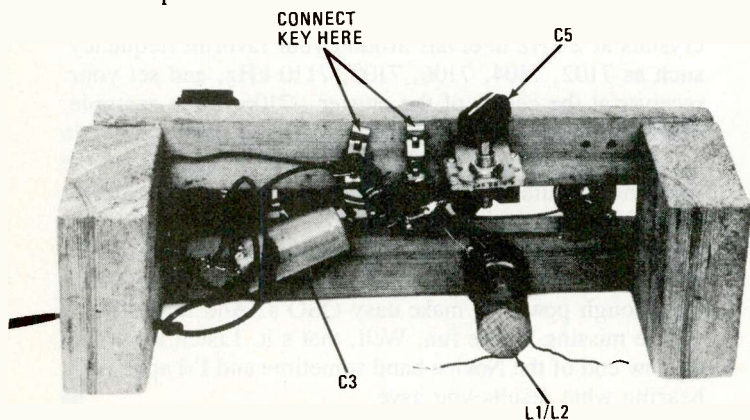

Some Old-Timer Tips

Fahnestock clips are used to connect the telegraph key and external multimeter. You could use the common multi-way binding posts that are so easy to get, but that would not have been done forty years ago.

The Gaseous-state Transmitter could be built much more compactly than it is shown in the photographs, and the wiring made more direct; but, it won't work any better, and it will be harder to build if you're a beginner.

The leads from the power transformer can be trimmed to the exact length if desired, but leaving them long doesn't hurt anything and you might want to use the transformer or other parts in another rig later.

There's nothing at all critical about assembling the Gaseous-state Transmitter. If you don't have the exact parts called for in the diagram, try using what you do have, or if you have some other ideas about construction, try them and see how they work. You could use a plywood panel and mount the variable capacitor on it, use an aluminum cake pan for a chassis, breadboard the rig, mount the tube upside down—try it and see! That's the advantage and fun of home-brew projects and simple RF transmitters.

Don't Become a Silent Key

Keep safety procedures always in mind! All high voltages should be kept out of reach whenever possible. Cover exposed high-voltage connections. Use a plastic bag over the key for added insulation. The high voltage used in the Gaseous-state Transmitter is dangerous.

About the Circuit

The Gaseous-state Transmitter uses one vacuum-tube, V1, as an electron-coupled oscillator. The crystal, XTAL1, is placed in the control grid-cathode circuit. The turn-on transient current flow within V1 shock oscillates the crystal so that it oscillates. The control grid regulates the current flow

Point-to-point wiring is what the transmitter's rat's nest is politely referred to—but it does the job! Three octal sockets are used; one as a tie point for the power supply, one to mount the vacuum tube, and one to mount the crystal.

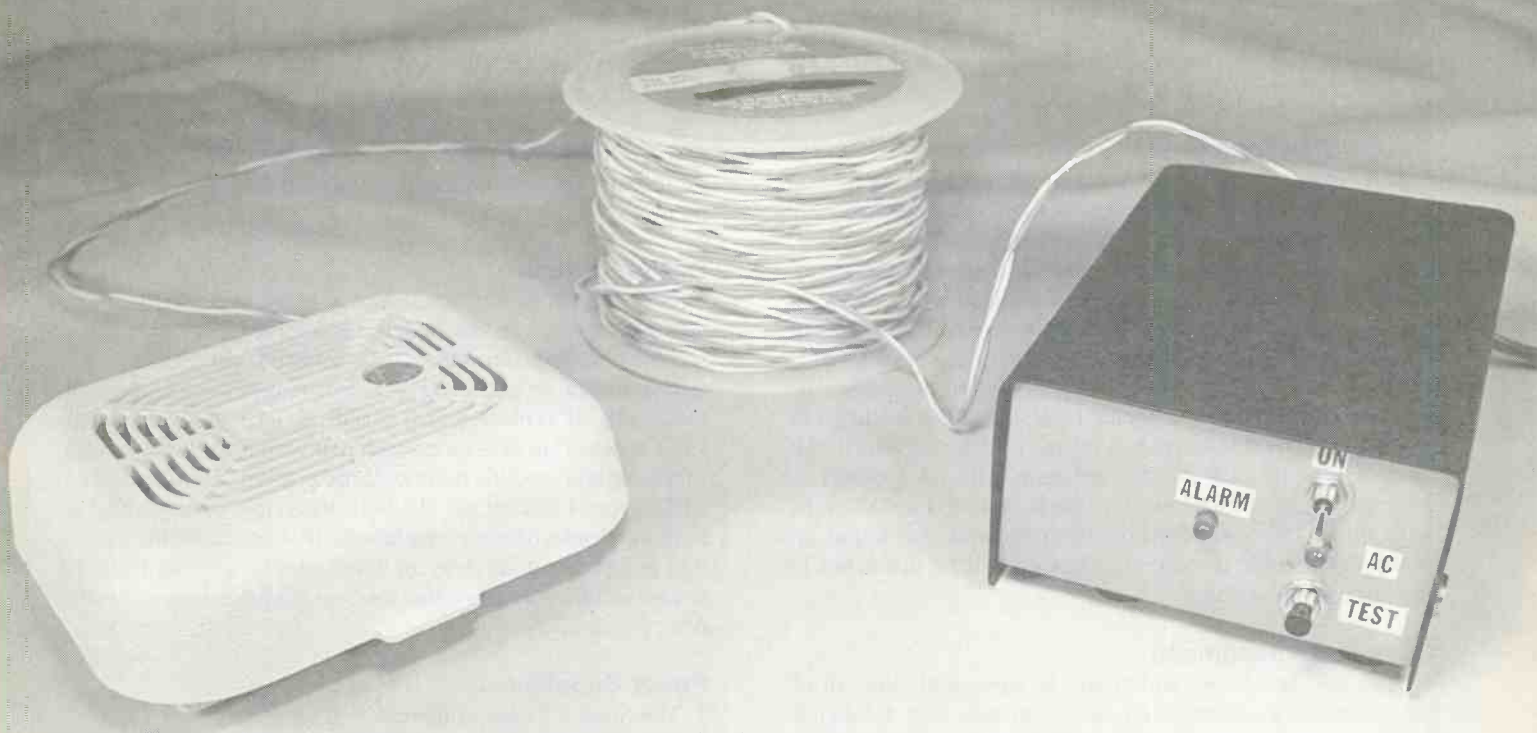

SMOKE BUSTER

Build our remote-sensor smoke detector!

By Richard J. Pearson

□ SYSTEMS THAT ALLOW THE REMOTE SENSING OF DANGEROUS conditions already exist and are available, but the quoted cost (not including installation) is in excess of \$200.00. Such a system can be built and installed for approximately \$40.00, and uses a standard “off-the-shelf” ionization-chamber type smoke detector as the sensor. In fact, any device containing normally open contacts (with closure affected during actuation) may be added to the system. An example of that application might be a temperature-actuated sensor.

Although UL-approved components are used, the system is not UL-approved and should not replace any existing protective devices the experimenter may have. The normal-operation test and fail-safe features of the smoke detector are retained. No modifications to the stock smoke detector are needed.

The primary source of power for the Smoke Buster is the AC powerline. A battery back-up sufficient for extended power failures is provided. LED status indicators, a test switch, and an audible alarm are present. We have attempted to make the design as fail-safe and reliable as feasible. We feel safe in stating that catastrophic failure cannot occur in the alarm system.

Smoke Detectors In General

Two basic techniques are used in the commonly available smoke alarms. They are: optical scattering of a light beam by smoke particles, and changes in the electrical conductivity of an *ionization chamber* due to smoke and/or combustion products.

The optical-scattering detection system directs light from a pulsed source through an optically-sealed chamber. The chamber is vented to permit room air to circulate through it. A photodetector mounted at 90° to the beam detects any light that may be scattered by smoke particles entering the dark chamber. That in turn actuates the alarm. In addition, a temperature sensor is usually incorporated to detect the heat from a clean-burning source of combustion.

In the ionization-chamber devices, an enclosed but ventilated chamber houses a small amount of radioactive material. The radioactivity causes the air between two closely spaced electrodes to ionize and become conductive. The small current that then flows is monitored. The presence of combustion products and/or smoke in the chamber results in a variation of the current flow between the electrodes. That in turn actuates the alarm. A discussion of the merits of the two methods is beyond the scope of this article; however, the ionization

**Here's a handy way to make your household
smoke detectors more useful and more reliable**

technique seems to be almost universally used in the low-priced, readily-available units.

Design Development

Our remote system was developed and tested using ionization-type detectors from a variety of manufacturers. We were unable to locate an optical-method unit for sale in our area; therefore, we have not tested, and do not recommend, attempting to use that type. The ionization-chamber devices are readily identifiable by a required disclosure on the outside of the box, which states, in effect, that a radioactive material is used and lists some pertinent NRC regulation numbers. The detectors were treated as "black boxes" and not modified in any way. Our remote alarm box connects to the existing 9-volt battery clip by a #22, twisted-pair wire. All power is provided by the Smoke Buster. We have tested installations with up to 150 feet of interconnecting wire and found no problem. Possible distance limitations will be discussed in the circuit explanation.

Observed Phenomena

With one exception, which will be discussed later, all of the commercial alarms were found to have the following characteristics: Standby current draw of 40-75 microamps; alarm-actuated current draw of 50-125 milliamps; a low-battery indication given by a "chirp" of the alarm horn at a regular interval of from 30 to 70 seconds; a 3-msec. wide, 15-milliamp pulse of current drawn from the supply at a 30- to 70-second repetition rate. The pulse is part of the battery test. When the internal resistance of the battery (or total series impedance of the battery circuit) exceeds approximately 75 ohms, the low-battery chirp starts. An alarm-test button was present on all units: Depressing the button activated the alarm if the unit was functional.

The one exception to the above parameters was an old smoke alarm installed years ago; it used a mechanical buzzer-

type horn rather than the newer piezoelectric transducer. The actuated current drawn was approximately 170 milliamps. The value of resistor R3 could be lowered to accommodate that style; however, since we have not tested them on a long-term basis, we recommend that only units of modern design be used.

Design Criteria

With the above characteristics in mind, a circuit was designed to feature: A smoke detector to give local alarm at the same time that the remote alarm is actuated; a smoke-detector test button to actuate both local and remote alarms; normal operation of remote-alarm circuitry indicated by status LED's; detection of open twisted-pair wire from smoke alarm to remote box; audible remote alarm with red *alarm-activated* LED; green LED for *AC OK* indication; low battery chirp at both the smoke detector and Smoke Buster; automatic detection of loss of smoke detector 9-volt supply; a backup supply in case of 117-VAC powerline loss; no modifications to smoke detector circuitry.

Power Supplies

The Smoke Buster contains three separate power sources. First, an alkaline battery provides the smoke alarm with its usual 9-volt supply via the twisted-pair wire. It also provides a bias voltage to a comparator circuit. No backup is used for the battery: Normal battery life is expected and battery aging will be indicated by the alarm-chirp feature. Catastrophic failure of that supply (unlikely) will cause the remote alarm to sound.

Second, a 15-volt supply of approximately 200-mA powered from the 117-VAC line provides the 1.2-mA current needed for the remote circuitry when in standby. When actuated, the current draw is approximately 40-mA. A green *AC, OK* LED indicates normal operation of the supply.

Third, a 12-volt backup is provided for the remote-alarm

PARTS LIST FOR THE SMOKE BUSTER

SEMICONDUCTORS

D1-D4—1N4004 1-A, 400-PIV, rectifier diode
LED1—Red light-emitting diode
LED2—Green light-emitting diode
U1—LM741 op-amp, (Radio Shack 276-007 or equivalent)
U2—7815 integrated-circuit, voltage regulator

CAPACITORS

(All capacitors are 35-WVDC, radial-lead, electrolytic units unless otherwise noted.)
C1—47- μ F
C2—10- μ F
C3—.047- μ F, 50-WVDC, ceramic disc
C4—100- μ F
C5—470- μ F

RESISTORS

(All fixed resistors are 1/4-watt, 10% units.)
R1—500,000-ohm, PC-board potentiometer (Radio Shack 271-339 or equivalent)
R2—180,000-ohm (see text)
R3—100-ohm (see text)
R4, R5—5600-ohm
R6—220,000-ohm

R7—1200-ohm

ADDITIONAL PARTS AND MATERIALS

B1—9-volt, alkaline battery
B2-B8—Size AA, alkaline batteries
BP1, BP2—2-position push terminal
BZ1—12-volt buzzer, (Radio Shack 273-055)
F1—3-AG
K1—Sensitive relay N.O. 12-mA (Radio Shack 275-004 or equivalent)
S1—SPST switch
S2—SPST, normally closed, pushbutton switch
T1—Power transformer; 117-VAC primary, 12.6-VAC secondary
AA, 8-cell battery holder, Proto Board (Radio Shack 276-170 or similar), 3 PC-board standoffs 3/8" high, AC line cord, line cord bushing (Radio Shack 278-1636 or similar), double-backed foam tape, 4 x 40 and 6 x 32 hardware, deluxe metal utility cabinet 4 x 2-3/8 x 5-7/8 (Radio Shack 270-252 or equivalent), wire: #22, stranded, twisted pair; #18 solid, insulated; #22 solid bare, #22 stranded, vinyl tubing, RTV silicone rubber, smoke alarm (see text), 5-lug tie-point, 9-volt battery clips, etc.

Get hands-on training for a high-paying career in today's booming electronic information industry as you build your own complete data communications system

Includes
XT-compatible
computer you
keep!

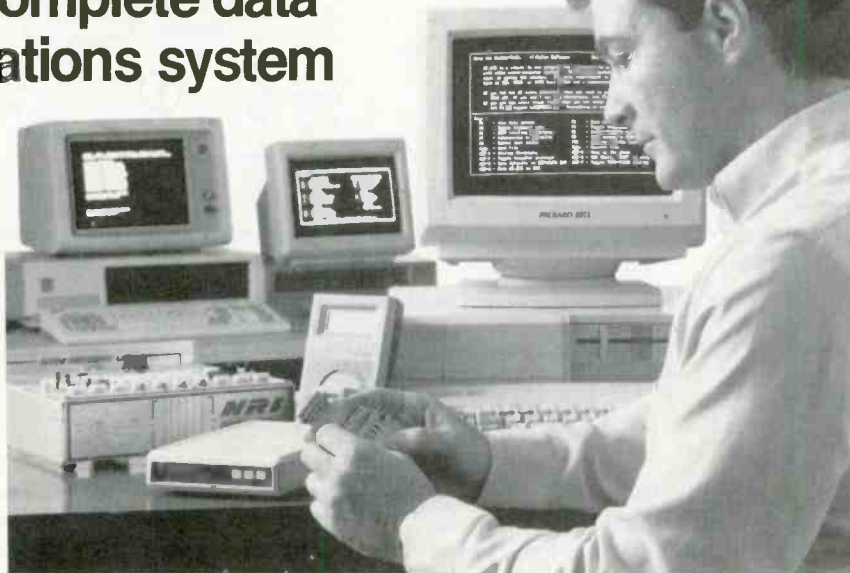

NRI's new Data Communications training gives you the high-tech, hands-on skills in demand in today's explosive new electronic information industry. Now with NRI, you actually build and go on-line with your own powerful data communications system, complete with IBM-PC/XT-compatible computer, 2400 baud modem, communications software, breakout panel, test instruments, and more!

It's a fact: The hot jobs in electronics today are in the electronic information industry. An explosion in new technologies is turning desktop computers into high-powered, high-speed data communications systems—making it possible for computers to talk to computers the world over.

Already, electronics technicians trained to install and service the new data communications equipment demand and get \$25,000, \$30,000, \$35,000 a year and more.

Now with NRI, you get hands-on data communications know-how, so you too can cash in on today's multibillion-dollar electronic information industry. NRI's ready to help you succeed now with new at-home training featuring a powerful data communications system you build, program, operate, and keep!

NRI trains you from the basics on up—giving you everything you need to get a fast start in data communications

Your NRI training starts with the electronics fundamentals you need to understand and service all data communications equipment. As you assemble your NRI Discovery Lab®, a complete breadboarding system included in your course, you perform experiments and demonstrations that show you electronics principles at work firsthand.

Quickly moving on, you use NRI's professional digital multimeter to take voltage, current, and resistance measurements, testing a variety of circuits you build on your

Discovery Lab—circuits just like those in today's data communications equipment.

And that's just the beginning. With a solid foundation in electronics behind you, you're ready to build your own powerful data communications system.

Breakthrough training includes 512K computer, 2400 baud modem, communications software, breakout panel, much more

At this point in your training, you're sent the new IBM PC/XT compatible Packard Bell VX88 computer. Following NRI's clearcut instructions, you easily master your computer's powerful operating functions, then move on to build your own complete data communications system.

You begin by programming the RS-232C communications interface built into your computer, giving the Packard Bell the power to transmit data over serial lines. Next you construct a high-quality breakout panel, an indispensable diagnostic tool you use to examine and test the internal workings of your interface.

Then, completing your state-of-the-art system, you power up the 2400 baud modem included in your course and take it through a series of comprehensive tests and demonstrations. In no time, you have a firm understanding of the data conversion system built into

your modem, and you're ready to put your system on-line with a world of electronic information.

Go on-line with the exclusive NRI network

Your NRI training continues by giving you exciting real-world experience in data communications.

Having completed your data communications system, you actually take it on-line to "talk" to your instructor and other NRI students, complete a final project by computer link, and leave messages on the NRI Bulletin Board.

Step by step, NRI gives you a complete hands-on understanding of the technology that's powering today's booming electronic information industry. Step by step, you get what it takes to start a high-paying career as today's in-demand data communications technician!

FREE 100-page catalog tells more

Send today for NRI's big, 100-page, full-color catalog describing every aspect of NRI's hands-on training in data communications, as well as at-home training in other fast-growing, high-tech career fields.

If the coupon is missing, write to NRI School of Electronics, McGraw-Hill Continuing Education Center, 4401 Connecticut Avenue, NW, Washington, DC 20008.

NRI School of Electronics

McGraw-Hill Continuing Education Center
4401 Connecticut Avenue, NW
Washington, DC 20008

For career courses approved under GI bill
 check for details

Check one catalog only

- Data Communications
- Computers and Microprocessors
- Robotics
- TV/Video/Audio Servicing

- Computer Programming
- Electronic Music Technology
- Cellular Telephone Servicing
- Security Electronics
- Digital Electronics Servicing
- Basic Electronics

Name _____ (please print) Age _____

Address _____

City/State/Zip _____ Accredited by the National Home Study Council 9-059

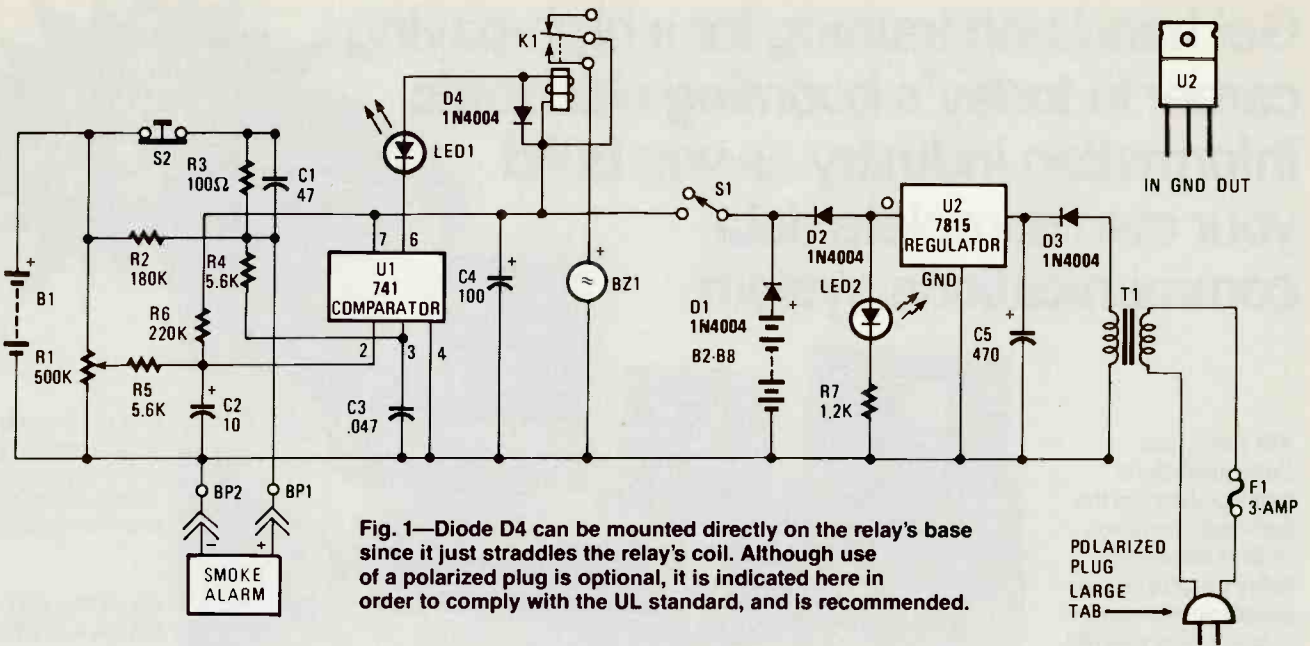

Fig. 1—Diode D4 can be mounted directly on the relay's base since it just straddles the relay's coil. Although use of a polarized plug is optional, it is indicated here in order to comply with the UL standard, and is recommended.

circuit. Failure of the AC power will allow the 15-volt bus to drop to 12 volts, but close regulation is not required by the circuit. That was done to keep the backup on-line current draw to a minimum.

Basic Theory and Circuit Operation

Circuit operation is simple (see Fig. 1). Current draw of the smoke alarm is sensed by the voltage drop across R3, which has a nominal value of 100 ohms. With the standby current being 50 microamps, for all practical purposes, the full 9-volt supply voltage appears via R4 at pin 3, the non-inverting input of the comparator. The 9-volt supply for the smoke alarm is also taken from that end of R3. When the alarm is actuated, the increased current draw results in a voltage drop of approximately 1.5 volts across R3. That falls below the comparison voltage on pin 2, which is set by R1 to 1/2 the total excursion, or a level of approximately 8.25 volt. The comparator output (pin 6) goes low, providing a current path through D4, the alarm LED, and the coil of K1, which are in series. D4 lights and K1 closes, thus activating the buzzer. The Smoke Buster may be silenced by turning S1 off. The smoke alarm can only be silenced by its normal reset or by disconnecting it from the remote box.

The low-battery chirp is initiated by the increasing internal resistance of an aging battery. Since R3 is in series with the battery, it would cause a false low-battery indication at all times. C1 is used to bypass R3 and provide a low-impedance path for the test pulse. As the battery ages and the alarm chirp starts, the resulting increase in the current-pulse width and

amplitude will also cause the remote-alarm buzzer to sound. Note that the contacts at S2 are not bypassed. Any excessive resistance that develops there would also be detected. A possible limitation to the length of the remote connecting wire may be imposed by the self-test feature. The effect of the increased shunt capacitance and series resistance of a long twisted pair is unknown. In any case, after installation be sure to repeat the low-battery simulation test given in the test and setup section of this article.

The open circuit (broken wire) test is provided by S2 and R2. Switch S2 is a normally-closed, momentary-contact switch in series with R3. When S2 is open, R2, which has a high value, effectively replaces R3 as the dropping resistor. If the circuit is intact, the normal 50- μ A current draw of the detector will drop the voltage enough to trigger the comparator and sound the remote buzzer. Note that that is a test of the Smoke Buster and smoke detector to the Smoke Buster circuit only. It does not test the smoke detector operation. That must be done using the smoke detector's test button and the procedure provided by the smoke detector's manufacturer.

Since the 9-volt battery provides both the reference voltage and the monitored voltage for the comparator circuit, a sudden loss of voltage from a loose battery clip or a broken wire could leave U1 in an indeterminate state. The divider network formed by R6, R5, and the setting of R1 insures triggering of the remote alarm if the 9-volts is ever lost. D1 and D2 isolate the 12-volt backup and the 15-volt supplies from each other. D3 is used as a half-wave rectifier to provide the DC input to the regulator chip (U2).

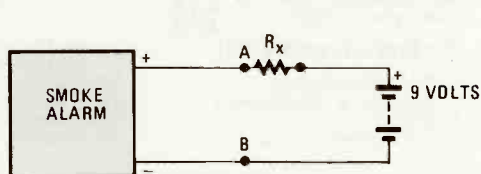

Fig. 2—Verifying the value for R2 is very important to ensure the proper functioning of the remote, and should be done before circuit-board assembly to avoid resoldering.

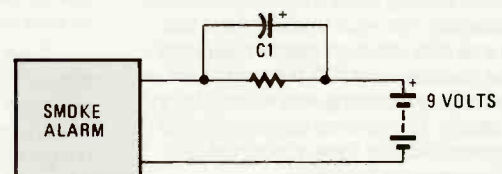
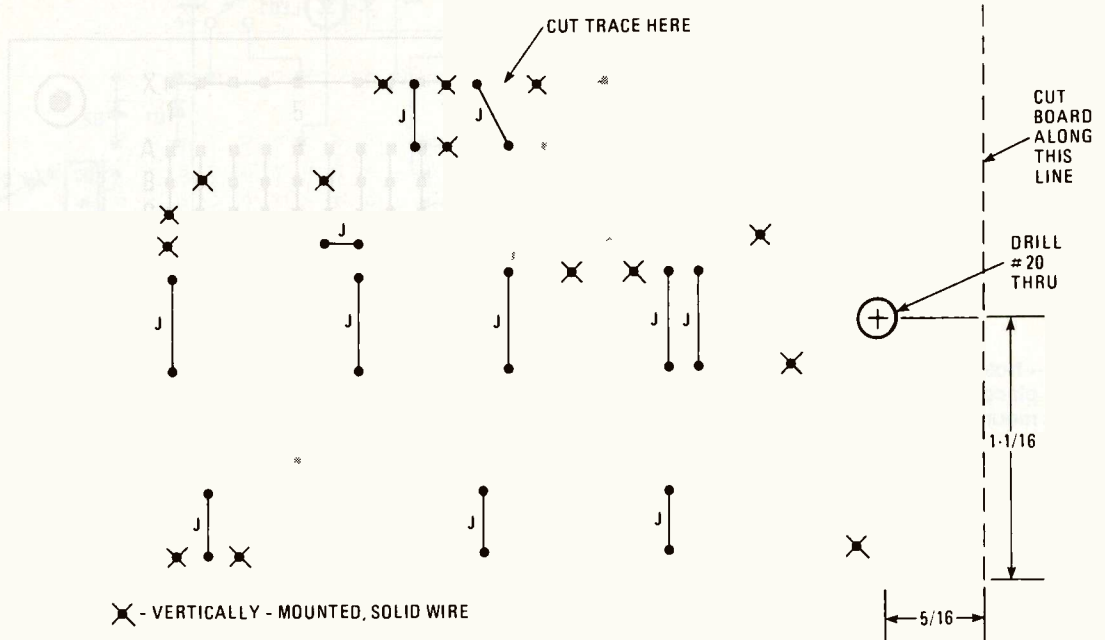

Fig. 3—The capacitor should be just high enough to keep the low-battery indication from occurring. For this test you must obviously be sure that the battery you use is in good condition.

Fig. 4—All jumper connections should be made before parts placement, as some jumpers will be beneath components. Mounting the solid wires in the locations shown will make testing and soldering the unit much easier. ▼



Construction

Before construction begins it is advisable to obtain the smoke alarm that you intend to use and verify the given values of R2, R3, and C1.

Using clip leads and a new alkaline, 9-volt battery, set up a bench test as shown in Fig. 2. In the standby mode a nominal 9 volts should be measured between points A and B. When the test button is depressed, the alarm should sound and the measured voltage should drop to between 7 and 7.5 volts. If necessary, alter the value of R3 to obtain the required voltage drop.

When allowed time to settle, most alarms will then give the low-battery chirp. Add C1 as shown in Fig. 3, and it should stop. We have noted variations in the value of C1 required by

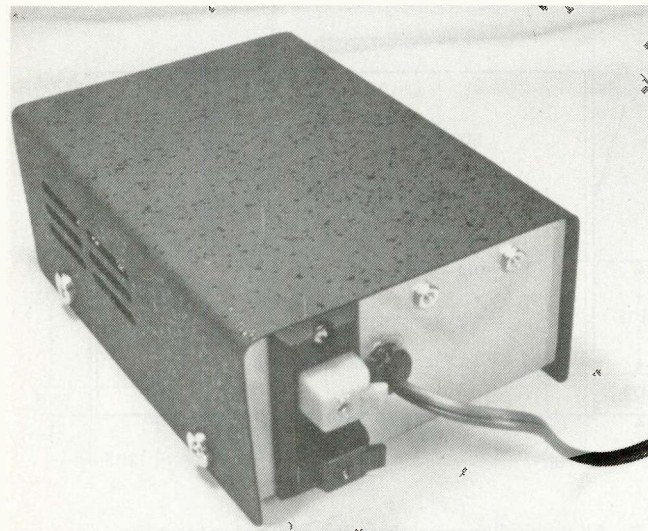

The two screws in the upper right are used to hold the buzzer in place. The strip on the left is used to connect the long zip-cord from the remote sensor to the remote power-supply box. Note that the AC line cord is fastened.

otherwise identical detectors and batteries. In some instances the value of C1 may need to be increased. Use only enough capacitance to eliminate the false *low-battery* indication. We also found many of the batteries supplied with the detectors to be in a discharged state right out of the box. Be sure that you are using a good battery.

The value required for R2 should also be verified at this time. The test setup should be as shown in Fig. 2 and the smoke alarm in the standby condition. The measured voltage from point "A" to ground should be less than six volts. If necessary, the value of R2 should be changed to achieve that voltage reading.

The circuit board used was a stock Radio Shack item modified as shown in Fig. 4. The coordinate system silk-screened on the board allows each hole to be easily identified. In most cases the component leads themselves form the runs. Short on-board jumpers are formed from solid, bare, #22 wire. The connections to off-board components are made using #22 stranded-wire (see Fig. 5). Since the technique of stranded wire soldering to small foil runs would try the patience of an archaeologist, we strongly recommend that #18, solid, insulated wire be used as shown for the stranded wire connection points. That method also allows easy test-clip lead and solder connections to be made after board installation. Note that some jumpers are partially covered by components and should be installed first as part of the board preparation. Use a small pencil-tip soldering iron and work neatly. Clean the flux and inspect for solder bridges before testing.

The sensitive relay is mounted as shown to the rear of the front panel using double-faced foam tape. To permit easy access to some solder points covered by the relay, install and wire it last.

Use appropriate sleeving on all bare relay wires. The unused lead should be removed or insulated and placed out of the way. Likewise, the unused transformer center tap (if any) should be taped.

Fig. 5—Note that diode D4 is not placed on the board, but is mounted directly on the relay. Mounting it somewhere between strips 10 and X reduces its effectiveness.

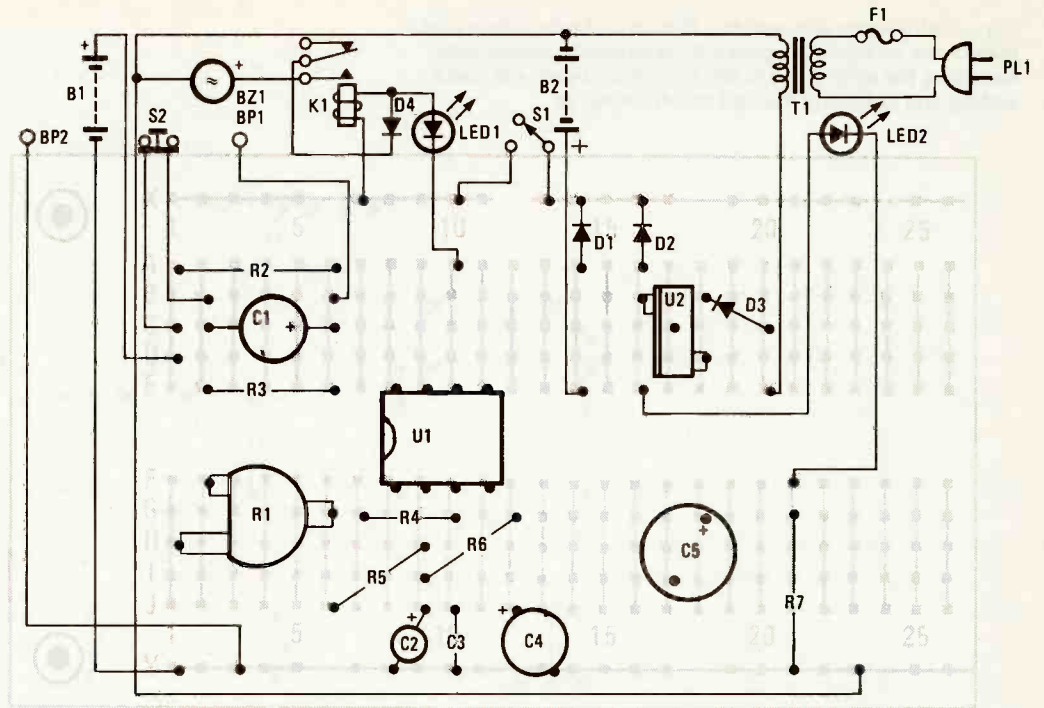

All circuit board and chassis modifications (see Fig. 6) should be made before starting assembly. With the exception of the relay, all chassis-mounted components should be installed before the final board installation and wiring. Note the proper positioning of the PC board standoffs as shown on the assembly drawing in Fig. 7. Also, be sure that the AC fuse is covered with sleeving (see Fig. 8), and all exposed terminals that carry 117-VAC have been completely covered with silicone rubber insulation as shown. It is advisable to wire and insulate the fuse, terminal strip, and transformer primary connections before installing the board.

The connection to a smoke detector's battery leads is made using a replacement 9-volt battery clip and leads. That will mate perfectly; however, one point must be noted: *When using*

the clip in that manner, the polarity of the leads will become reversed. Red should now go to the negative or ground and black to the positive 9-volt connection. Solder the twisted pair to the battery clip leads and use the appropriate shrink tube or electrical tape for insulation and structural support. When routing the wire from the detector to the Smoke Buster, avoid parallel runs with house wiring and avoid other noise sources such as fluorescent lights or electric motors.

Bench Setup and Testing

Temporarily connect the smoke alarm. Set R1 fully CCW. Connect the 9-volt battery. Do not connect the 12-volt backup yet. Plug the line cord into a suitable outlet and turn the remote-alarm switch on. Check for 15 volts at U1, Pin 7.

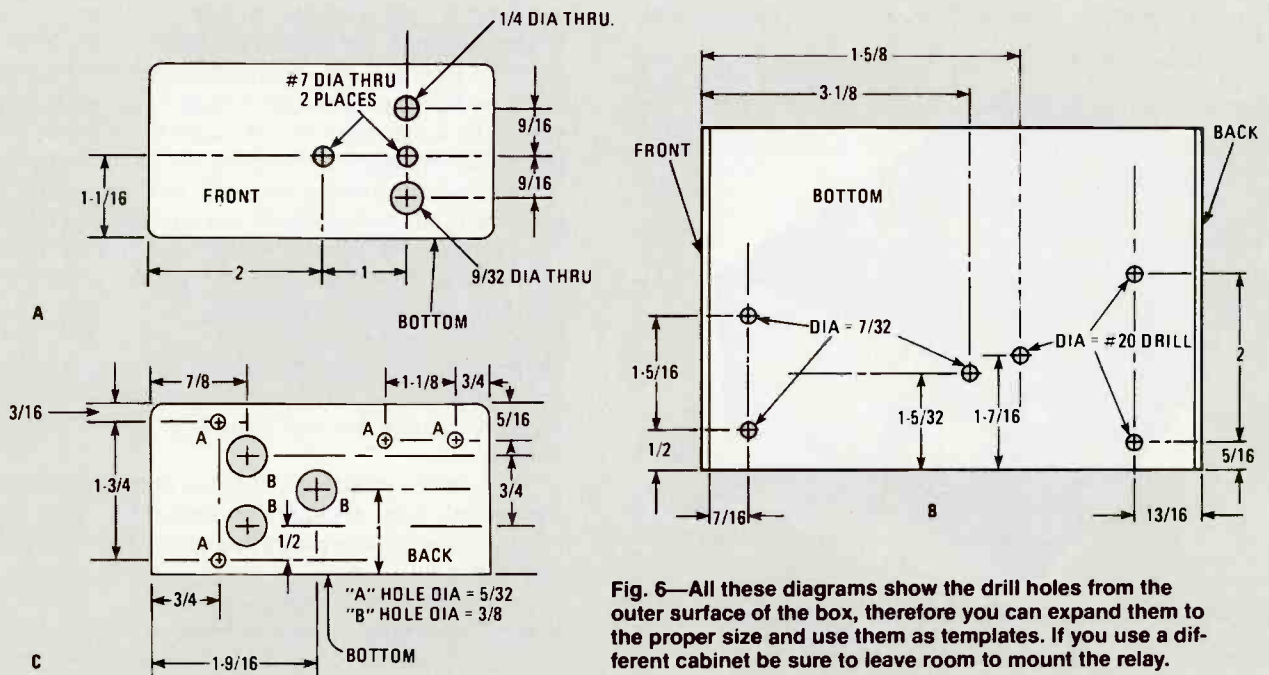

Fig. 6—All these diagrams show the drill holes from the outer surface of the box, therefore you can expand them to the proper size and use them as templates. If you use a different cabinet be sure to leave room to mount the relay.

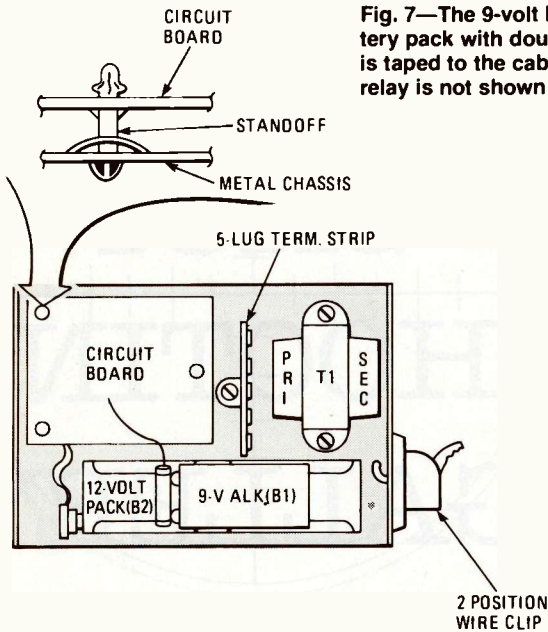

Fig. 7—The 9-volt battery is held on to the top of the battery pack with double-sided foam tape, and the battery pack is taped to the cabinet in like fashion. The placement of the relay is not shown here, but goes in the upper left corner.

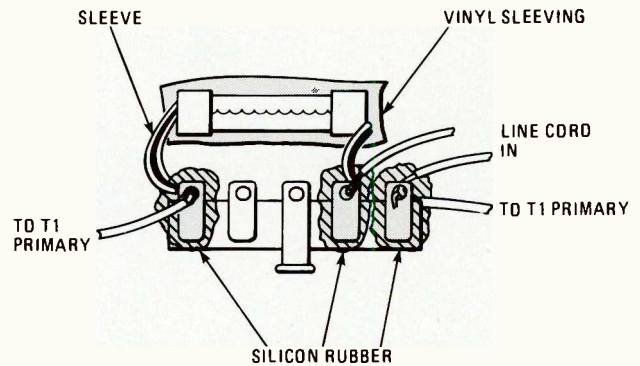
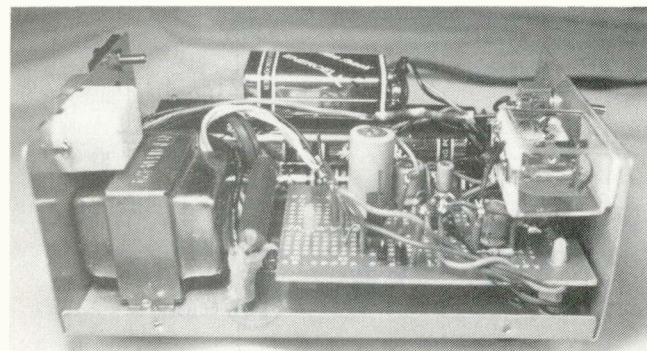

Fig. 8—The hot terminals are the only ones requiring silicon to protect you against shock. Be sure not to use the grounding center lug for your connections as it may expose the circuit and user to unsavory voltages.

Check the voltage at U1, Pin 3. It should be at the 9-volt level or very close. Using R1, set the voltage at U1, Pin 2 at .5 volts less than the voltage at U1, Pin 3 (8.5 volts nominal). Connect the 12-volt backup battery, remove the AC line cord from the receptacle and check U1, Pin 7 for a nominal 12 volts. Recheck the voltage at U1, Pin 2. It should be around .7 volts less than the U1, Pin 3 level (8.2 volts nominal). Monitor the voltage at U1, Pin 3. Depress the smoke alarm's test button. The alarm horn and the remote buzzer should sound, and the alarm indicator light should show from 1.5 to 2 volts less than in standby mode. Depress the remote box's test switch. The remote buzzer should sound, and the alarm light illuminate. The smoke-alarm horn will not sound. Disconnect one lead to the smoke alarm from the remote box and press the remote-test switch again. No alarm indication should be given. That is the broken-circuit indication. Restore the connecting wire and, using a jumper, short the remote output terminals together. The Smoke Buster's buzzer and light should sound. That is the short-circuit indication. Insert a 100-ohm resistor in series with either of the leads going to the smoke detector. After a short time, the low-battery chirp should begin. The remote-alarm LED should flash and the buzzer sound in time with the chirp.

NOTE: Restore the AC power and repeat the foregoing.

Remove the line cord from the AC receptacle, replace the cover, and, using an ohmmeter set on a high ohms range,



Note that the relay is fastened to the inside front panel of the cabinet with double sided foam in such a way as to avoid harming the components or the user.

check to ensure that no leakage path from the AC powerline to the chassis or remote output terminals exists.

Installation

The smoke detector should be positioned and installed according to the manufacturer's recommendations. The interconnecting #22 stranded, insulated twisted-pair wire should be run following good wiring practices. When the installation is complete, test the system on both AC and backup power.

Some smoke detectors will draw enough current during the battery-test pulse to cause the remote-alarm LED to flash. That indicates normal operation as long as the low-battery chirp is not present at the smoke detector. Increasing the value of C1 will eliminate that flash, but be sure to repeat the low-battery simulation using the series resistor to ensure that the remote unit will still respond to a valid low-battery chirp.

Since the Smoke Buster will trigger on any current draw greater than a threshold of approximately 7-mA in the sensor loop, other sensors could be added. They must be of the normally-open, closed-contact upon activation type, and draw no power while in the standby state. A suggested hookup is shown in Fig. 9. Remember, the remote box has no latching feature and will only sound as long as the contacts are closed.

Be sure to test both the smoke alarm and the Smoke Buster on a regular basis. The 12-volt, remote backup battery should be replaced on an annual basis or more often if an extended power outage is experienced.

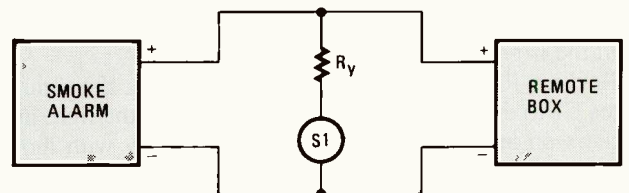
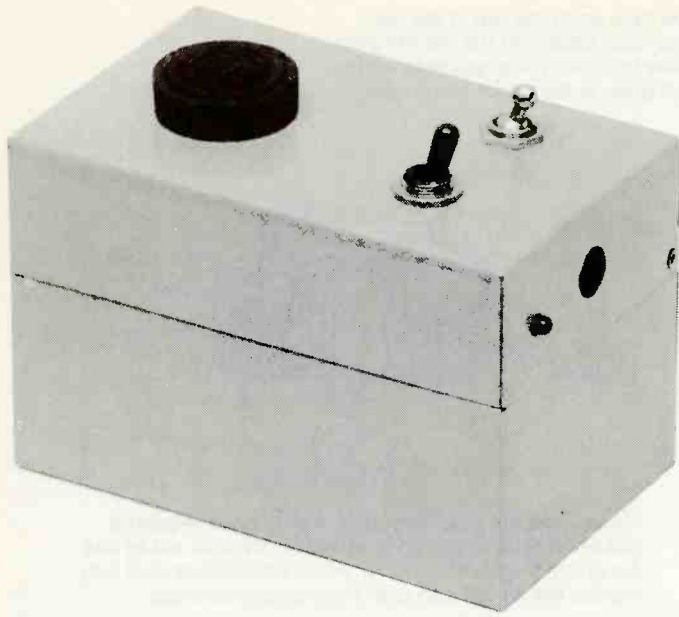

Fig. 9—Connecting extra heat-sensitive devices is possible but will have to be done as a test. To do this, set up the system as shown using a potentiometer for Ry, place a soldering iron close enough to the heat sensor to raise it to the temperature you wish triggering to occur at, then slowly lower the potentiometer resistance till the alarm sounds. Replace the pot with a resistor.



THE ONE SHOT SHOOTING GALLERY

This easy-to-build project is no shot in the dark. It'll let you practice some shoot'n if you can get it away from the kids.

By Evert Fruitman, W7RXV

WHO HASN'T ENJOYED A VISIT TO THE COUNTY FAIR and lingered at some of the action booths, particularly the shooting gallery? Several clay ducks later you walk off with a big stuffed toy. You had a good time plinking away at the targets, and wished that you could take home more of the fun. You can! The *One Shot Portable Shooting Gallery* makes a good rainy day project.

The One Shot gets its name from the way the light generator works: it gives just one burst of light per trigger squeeze. The target responds only to rapid light-level changes; therefore, it works well in normal room lighting. My children can pick off the target at 15–20 paces. I wish I could do as well.

How it Works

The *gun* is simply a two-cell penlight with a few additions. Two transistors are used to form a sensitive electronic switch. A small burst of current from a capacitor turns the switch on.

That connects the battery across the light bulb long enough for it to emit its one shot. Holding the trigger, (on/off switch) down connects R1 to the base of Q1. That allows C1 to dump its charge (see Fig. 1). Resistor R1, the 39,000-ohm resistor, passes too little current to recharge C1 with the switch on, and it can't supply enough current to keep the transistor turned on either. Make R1 too big and you wait too long between shots. Make it too small, and it will keep the light on as long as you hold the trigger down.

Resistor R2 adjusts the on time by changing the time it takes C1 to discharge. Make R2 too small and the light just flickers on and off as you trigger it. We'll play with those adjustments to get variable-length light bursts in the Outer-Space model.

Our Outer-Space model in Fig. 2 has one more resistor, switch, energy cell, and diode, than the Earth-bound model. The additional parts buy us more range, and two burst times. The longer burst—almost one second—lets us zero in on distant targets; the shorter time gives us the ability to blast away several times a second.

The basic operation remains the same as the circuit of Fig. 1. We put a switch and two resistors between the timing capacitor and the base of Q7. The smaller resistor (270 ohms), gives a shorter burst time.

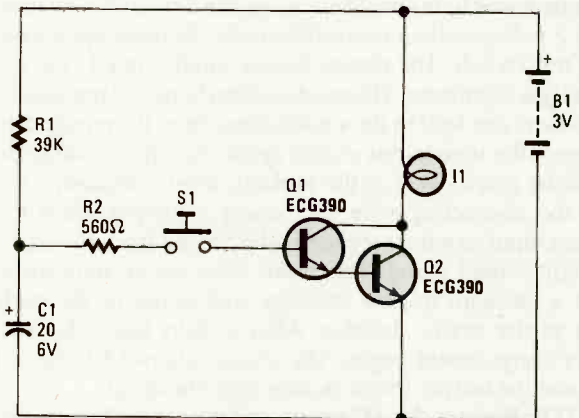

Fig. 1—This is nothing more than a transistor controlled flashlight. It emits one blip of light so that the user cannot just keep his/her finger on the trigger.

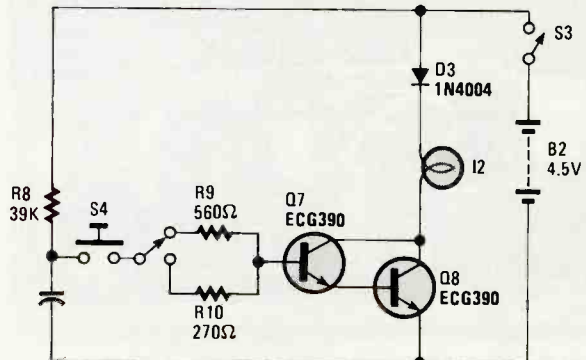

Fig. 2—This unit has selectable pulse times. Switching the low resistor into the circuit allows you to rapid fire.

The diode between the power and the lamp drops about 0.7 volts, which extends the lamps life. Without the diode the lamp would give bright light bursts, but for such a short time.

The extra battery does give us some benefits. The additional battery lets the timing circuit, R8 and C, rapidly charge up to the firing voltage.

Both systems use a small cheap plastic lens to focus the lamp output on the target. It concentrates the energy into a relatively small beam. That, coupled with sensitive photo transistor in the targets, gives either system a more than 20 foot range.

The Targets

You can use anything that reflects light for a target. But you can have more fun when the target tells you that you scored a hit. The portable, four-transistor target in Fig. 3., gives visual and audible announcements that you scored a hit. The more elaborate model in Fig. 4. includes a simple music synthesizer; you can use bells, whistles, or sirens, if you like.

Target Basics

The simpler target consists of a photo cell, a pulse amplifier, a pulse stretcher, an LED driver and an LED. As you can see in Fig. 3, the circuit is quite a bit simpler than it sounds.

The LED gives silent visual signals while a piezo buzzer gives audible announcements. The LED stays in the circuit all the time. A switch removes the noise maker for those times when silent practice suits the mood of the moment. You can customize the noise maker to get any effect you want.

Design vs. Sensitivity

Either a CdS photo cell or photo transistor (Q3) will work in this circuit. Although the transistor gives greater sensitivity, the circuit operates the same either way.

When light strikes the sensitive surface on the sensor, its resistance decreases. The brighter the light, the lower the resistance. The faster the light level changes, the faster the voltage changes across the cell and across R3. Capacitor C2 couples only relatively fast voltage changes to the next stage. That lets the target respond to pulses from the gun, even in a room with a rather high, but steady, light level. That also means that if you point the target at a TV screen or a fluorescent light, it will sound off. The cure for that costs some sensitivity, but nothing that you will miss.

The basic target in the card-file box, has enough sensitivity to respond to a television picture tube more than five feet away. The synthesizer version of Fig. 4, uses R12 and C5 to

desensitize itself. The circuit works the same as the system we will describe below for Fig. 3. With the addition of R12 and C5 though, the target has to be less than 24 inches from a TV to see the picture. despite that, it will still sound off when you hit it with a gun burst from 15-20 paces.

Earth-Bound Circuit

When Q3 detects a light burst, C2 adds a small current pulse to the base bias supplied by R4. That causes Q4 to conduct less. That allows the current from R5 to flow through diode D1 and charge C3. The diode forces C3 to discharge through R6 and Q5 after the pulse ceases.

When the voltage across C3 reaches about 1.2 volts, Q5-Q6, (the double emitter-follower hook-up known as a Darlington pair) turns on. When Q6 turns on, it connects R7 and LED1 across the battery. Resistor R7 limits the current to about 9 milliamps. You may adjust the current for a brighter light by changing the size of the resistor. Connecting the noise maker from the battery + to the collector of Q6 through a switch, lets you control the sound.

Diode D1 and capacitor C3 form a pulse stretcher. Rather than carry off dead pulses, that circuit lengthens the short pulses delivered by C2 to Q4. Without the stretcher, the short light burst from the gun would get little more than a quick flicker out of the LED, and a buzzer would give a quick tick. By making R6 bigger, you lengthen the on time for Q6, and therefore the light-on time.

Power Drain

Except for the time during which the target responds to your gun pulses, it draws little current, about one-tenth of a milliampere. Even the cheaper batteries would have a long life. If you use an extra-loud sound module, or a music synthesizer like that in Fig. 4, you will want to use heavy-duty batteries, or a plug-in power supply.

To add sound, you may use a commercial siren module or you may make a custom noise maker such as the simple synthesizer shown. For heavier loads such as a bell or a motor, use a relay with its coil connected between +V and the collector of Q6.

The Synthesizing Target

The synthesizer in the advanced model is just a non-symmetrical multivibrator. It changes frequency with changes in voltage as a pulse works its way through the circuit.

Until a pulse starts its journey through the unit, Q12 is

turned off. That lets current flow through LED2, R16, and R17, to keep Q14 turned on, (fully conducting). When a pulse works its way through to Q11, it turns on Q12 and LED2. That in turn delivers a short pulse through the switch Q13-Q14 to D2, C8, and R19, which supplies turn-on bias to Q15.

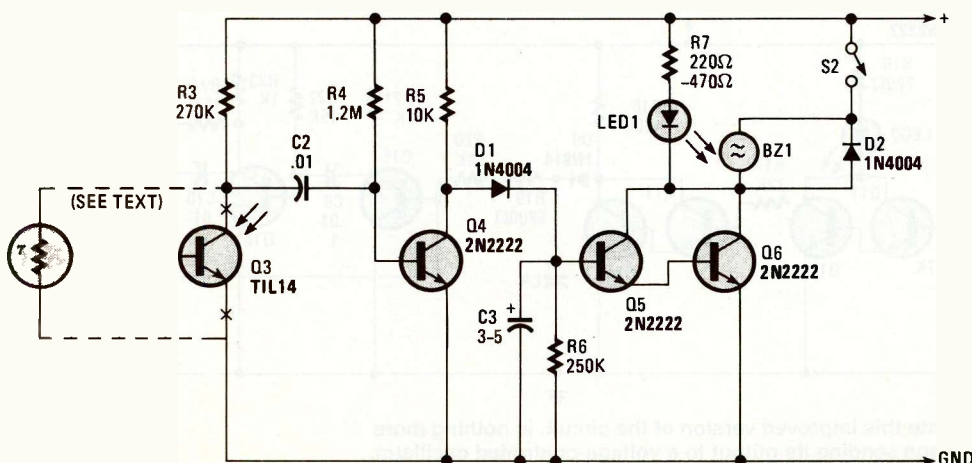
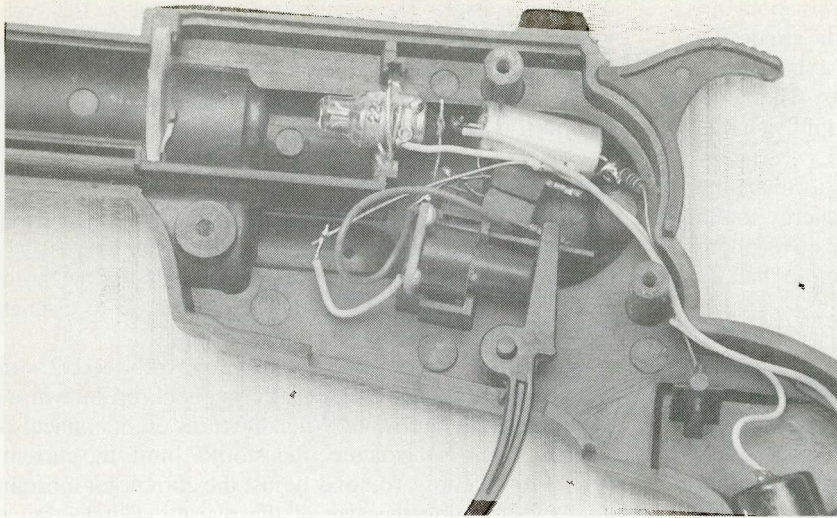

Fig. 3—Either a phototransistor or photoresistor (such as a CdS cell) can be used in the circuit as a light sensor. Its signal is stretched and fed to a switching circuit.



Selecting a bulb with an on-center filament is the most important step. No amount of adjustment can make up for a poor bulb, so chose it wisely.

plastic gun, then use the case for the Outer Space model. Start either one with the light bulb.

Look at the light bulb before you install it. Some of them have an off-center filament. That kind will shoot crooked. When you find a good bulb, center it at the focal point of the lens. Move the bulb closer to and farther away from the the lens until they are aligned. Connect two penlight cells to the bulb and point the lens and bulb assembly at a wall or other light-reflecting surface. As you adjust the lens, you should see a well-focused spiral pattern indicating proper alignment. Much of the range the instrument has, comes from proper lens alignment. It aligns easier than it sounds though.

Transistors Q15 and Q16 form a simple non-symmetrical multivibrator. It changes frequency with changes in voltage; that, coupled with its lack of symmetry, gives it a somewhat musical sound. The multivibrator can run only during the time that the second pulse stretcher (composed of C8, and R19) turns on Q15. Resistor R24 couples the signal from Q16 to Q17-Q18, another Darlington pair. They drive the loud-speaker.

While waiting for a pulse, R22 keeps Q16 turned on which keeps Q17-Q18 off. That reduces the standby power drain. The target draws about 13 mA during standby periods and about ten times that when loudly proclaiming a hit. Even heavy duty 9-volt batteries would have trouble supplying that much current. A small game-module power supply could handle that without trouble. I found it just about as easy to build a small plug-in power supply for the unit. It uses a transformer, four diodes, and a single filter capacitor. Add a fuse for protection and an on/off switch for convenience as in Fig. 5.

Gun Alignment

The gun I used came from the *as is* table at a Radio Shack store. It had the lens and switch in it. You can probably find a similar unit at a toy store.

My wiring does not always follow formal techniques as the cut-away view shows. The parts mount directly by their leads in the (plastic) shoot'n' iron. If wiring parts together by their leads doesn't appeal to you, or you can't find a suitable

Gun Wiring

Wire the transistors, resistors and other parts together. When you complete the gun, point it at a nearby wall and fire it. You should see a short, bright light burst. With only two cells and the slight voltage loss in the transistor switch, the bulb and batteries will live long.

If the Outer Space model is more to your liking, the parts can go into any housing, that gives room for the extra parts and allows you to adjust the distance from the lens to the bulb. If you can find a shorter focal-length lens, say one to two inches, you can use a short box.

Mount the lamp socket. Determine where the lens will sit and drill a hole in the case, centered on the lamp. Cement the lens in place. Then focus the lamp as mentioned before. After that, mount the switches, wire the boards, and install them.

Although the batteries in our Outer Space model give long life, you may want to add a flashing pilot light. It can consist of a cross-coupled flip-flop with an LED in one of the collector circuits (see Fig. 6). Since it uses non-electrolytic capacitors, it takes up little space. A pilot light would add little to the battery drain, and would give the system that ready-for-action look.

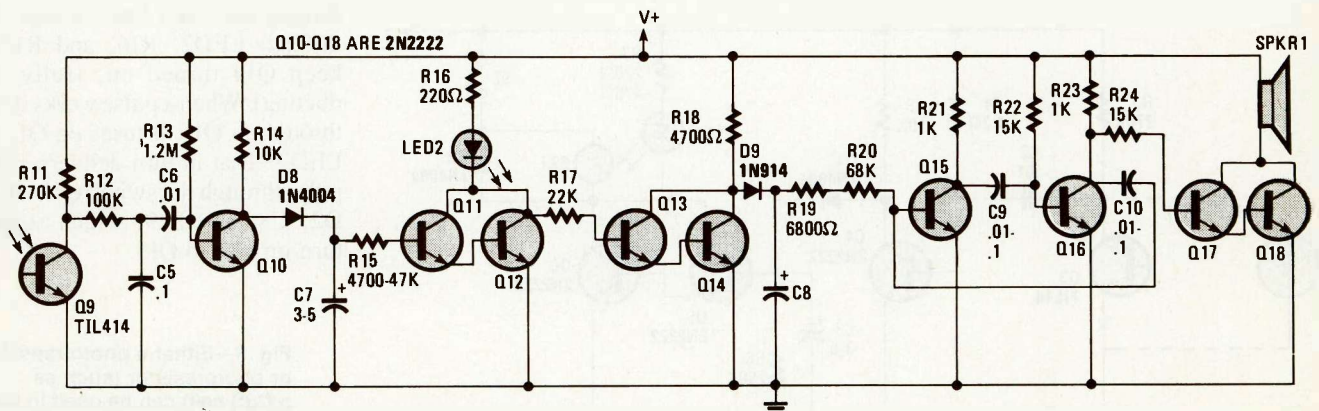

Fig. 4—The synthesizer added onto this improved version of the circuit, is nothing more than another pulse-stretching stage sending its output to a voltage-controlled oscillator.

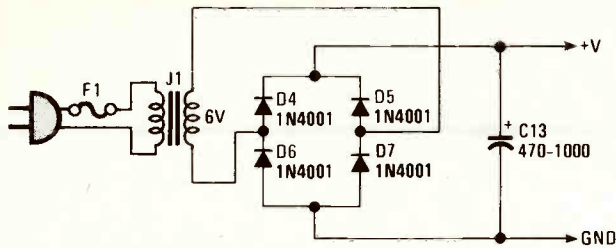

Fig. 5—The synthesizer model, or any souped-up version of the targets using external hit indicators which draw a lot of current, should make use of this power supply.

Target Construction

As the photo shows, the target could go in something smaller, but I used the first loose card file box that I found. They usually sell for about half the going rate for a project box. The photo sensor, whether photo conductive or photo transistor, needs shade from direct room lighting. I mounted the cell on the side of the piezo sounder which put it three to four inches away from the opening. Since the box had room to spare, I used up some of the older, larger toggle switches that don't lend themselves to miniature construction. The LED mounts by one lead to one side of the sound/silent switch. A dot of cement secures it in a hole in the side of the box.

The amplifier fits comfortably on a scrap of perfboard, which mounts by a short, stiff wire. Mount the switches and the noise module. Wire the board and attach the wires to the module and the switches. The battery clip can come from an old battery. An "L" shaped clamp holds the battery in place.

Sounding Off

The piezo sounders give a lot of sound for a small amount of current. Typically they have an oscillator built into their resonating cavity. You can buy just the piezo element and add your own oscillator, although in this case it seems to offer little economic advantage.

The sounder used here was left over from another project, but its cost prompted the simple synthesized musical sound system for the advanced version of the shooting gallery. A siren or other commercially-built noise module could prove simpler than building your own. It depends upon how much

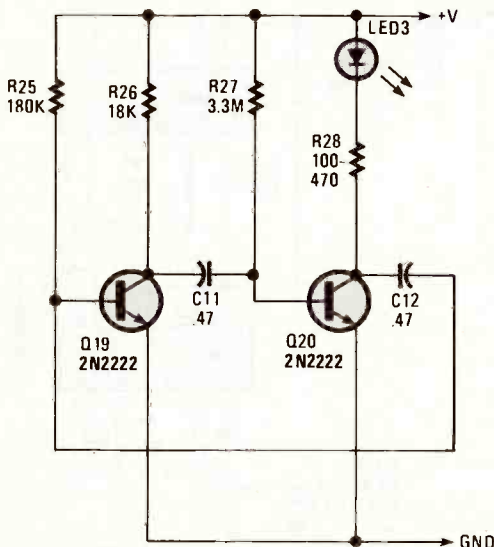

Fig. 6—You can add this flashing pilot light to your gun to give it pizz. It drains little power and tells you the unit is operating. It can make an unusual sight.

noise you want.

Unless you plan on using a game module power supply (6–12 volts at 150–200 mA should do it) build the power supply first, then check it out. It will deliver about 8–10 volts with no load. That will fall to 7–8 volts depending on the load.

Wire the main board next. When that checks out you can add the sound module or wire the synthesizer.

Check-Out Time

We already gave some check-out tips for the One Shot shoot'n' iron; some tips on checking on the other parts of the system may prove helpful. We will start with the light gener-

(Continued on page 154)

PARTS LIST FOR THE ONE SHOT

CAPACITORS

- C1, C4—20- μ f, 6WVDC electrolytic
- C2, C6—0.01- μ f
- C3, C7, C8—3–5- μ f
- C5—0.1- μ f
- C9, C10—0.01–0.1- μ f
- C11, C12—0.47- μ f
- C13—470–1000- μ f, 15WVDC

RESISTORS

(All fixed resistors are 10% 1/4-watt units.)

- R1, R8—39,000-ohm
- R2, R9—560-ohm
- R3, R11—270,000-ohm
- R4, R13—1,200,000-ohm
- R5, R14—10,000-ohm
- R6—250,000 (220,000 + 27,000)-ohm
- R7—220–470-ohm
- R10—270-ohm
- R12—100,000-ohm
- R15—4700–47,000 adjust as needed for desired effect
- R16—220-ohm
- R17—22,000-ohm
- R18—4700-ohm
- R19—6800-ohm
- R20—68,000-ohm
- R21, R23—1000-ohm
- R25—180,000-ohm
- R26—18,000-ohm
- R27—3,300,000-ohm
- R28—100–470-ohm

SEMICONDUCTORS

- D1–D9—1N4004 diodes or equivalent
- LED1, LED2—Any color light-emitting diode
- Q1, Q2, Q7, Q8—TIP33, ECG390, or equivalent
- Q3—TIL14 IR phototransistor, or equivalent (or CdS photocell; see text)
- Q4–Q6, Q9–Q20—2N3904, 2N222, or equivalent

ADDITIONAL PARTS AND MATERIALS

- BZ1—piezo buzzer with built-in oscillator
- I1, I2—#222, 2.5-Volt, 1/4-Amp. bulb
- SPKR1—2-in., 8-ohm speaker (for synthesizer)
- S1, S4—momentary-contact switch
- S2, S3—SPST switch
- S4—SPDT switch
- T1—12-Volt, center-tapped transformer (RS 273-1385 or equivalent)

Relay 275-230 or 275-244 needed only for high current loads, enclosure, plastic gun, lamp socket, small plastic or glass lens, misc. hardware etc.

Build the Digital Theremin

IT'S A COMMON MISCONCEPTION THAT ELECTRONIC MUSIC did not exist until Robert Moog introduced his synthesizer in the mid-1960's. Actually, experiments with electronics and music go back to pioneering efforts at the turn of the century. While much of the early work has faded from the pages of history, a few have managed to live on to this day.

One of the earliest efforts was the theremin. Named after its inventor, the theremin was developed in the Soviet Union in the early 1920's. It consisted of a box fitted with a pair of antennas. There was no keyboard to play, no strings to strum or bow. Instead, the theremin used the body capacitance of the performer to control the pitch and volume of the output signal. All the user had to do was wave his or her arms near the antennas to produce sound!

The biggest use of the theremin has been in untold numbers of grade-B horror pictures. The eerie gliding sounds that can be heard during the action came from the theremin. It has also been used in pop and rock music as well—Jimmy Page of Led Zeppelin used one in concerts for many years. While the original theremin used two antennas and a slew of tubes and tuned circuits, the use of integrated circuits makes the job considerably easier.

In this article, we'll describe the construction of a simple

theremin with under \$20 worth of parts. Experimenters with a junkbox will be able to do the job for even less money. The theremin is easily assembled and used, even by those without a musical background. Best of all, the theremin is lots of fun, especially at Halloween parties!

The Inside Track

In our design, the tubes and tuned circuits have been replaced by a pair of inexpensive and easy to find IC's, to produce the Digital Theremin. A block diagram of the circuit is shown in Fig. 1. The Theremin uses a pair of high-frequency oscillators for operation. While one oscillates at a fixed frequency, the second can be varied by the body capacitance of the user. The output of the two oscillators are mixed by a special circuit known as a balanced modulator.

The balanced modulator suppresses the original inputs and produces a complex signal that consists of the sum and difference frequencies of the two inputs. If one oscillator is operating at 100 kHz and the other is operating at 101 kHz, the output will be two frequencies at 201 kHz and 1 kHz. Since the upper range of human hearing is limited to 20 kHz or so at best, only the 1 kHz difference frequency would be audible when the balanced modulator is connected to an audio amplifier.

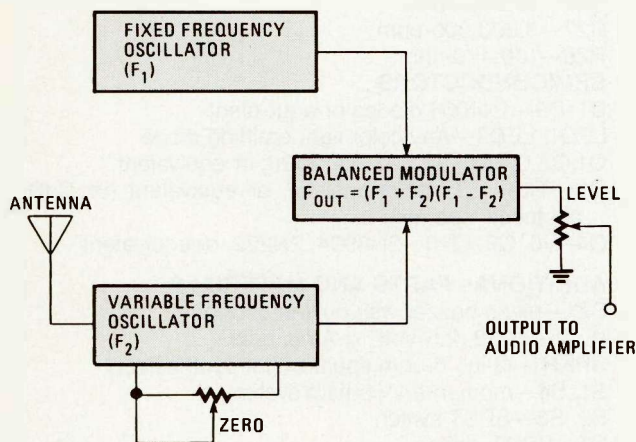

Fig. 1—The block diagram of the Digital Theremin shows a pair of high-frequency oscillators—one oscillating at a fixed frequency, and the other variable via body capacitance. The outputs of the oscillators are mixed by a balanced-modulator circuit, which suppresses the original inputs to produce a complex derivative, consisting of the sum and difference frequencies.

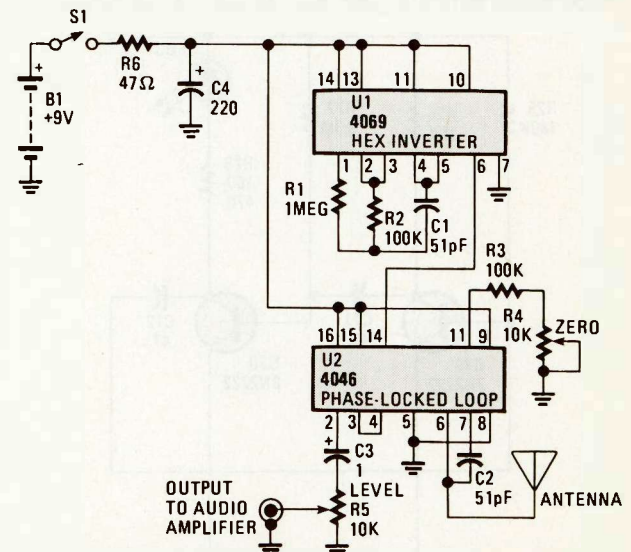

Fig. 2—The schematic diagram of the Digital Theremin shows U1—a 4069 hex inverter/buffer—used as a fixed-frequency oscillator, while U2 (CD4046, a phase-locked loop) serves as a variable-frequency oscillator.

Now you can produce those eerie sounds that lend a chilling effect to horror movies!

By C.R. Fischer

Straight to the Heart

The schematic diagram for our Digital Theremin is shown in Fig. 2. U1—which can be either a CD4069 or 74C04 hex inverter—is used as a fixed-frequency oscillator centered around 100 kHz. U2 contains the variable frequency oscillator and balanced modulator to complete the rest of the circuit. The CD4046 is a phase-locked loop and was originally designed for applications like frequency multipliers, but its hardware fills our needs perfectly. R3, R4, and C2 determine the center frequency of the on-chip oscillator.

The antenna forms a parallel capacitance with C2, which allows the frequency to be shifted several kilohertz by bringing a hand near the antenna. R4, the ZERO control, allows the variable oscillator to be set to the same frequency as the fixed oscillator. When the difference frequency is below 15 Hz, it is below the lower frequency limit of the ear. By setting both oscillators to the same frequency, the Theremin remains silent until the performer brings his or her hand near the antenna.

The oscillators are mixed by an exclusive OR gate inside the 4046. That gate acts as a digital balanced modulator, which produces the sum and difference frequencies as explained earlier. The output of the gate is then AC coupled by C3 to LEVEL control R5 and an output jack for connection to an audio amplifier or stereo receiver.

A 9-volt transistor-radio battery is used for power, con-

PARTS LIST FOR THE DIGITAL THEREMIN

- C1, C2—51-pF, silver mica capacitor
- C3—1- μ F, 25-WVDC electrolytic capacitor
- C4—220- μ F, 25-WVDC electrolytic capacitor
- R1—1-Megohm, 1/4-watt, 5% resistor
- R2, R3—100,000-ohm, 1/4-watt, 5% resistor
- R4—10,000-ohm, linear-taper potentiometer
- R5—10,000-ohm, audio-taper potentiometer
- R6—47-ohm, 1/4-watt, 5% resistor
- U1—4069 or 74C04 CMOS hex inverter/buffer, integrated circuit
- U2—4046 phase-locked loop, integrated circuit

ADDITIONAL PARTS AND MATERIALS

Printed-circuit or perfboard materials, general-purpose replacement antenna (Radio Shack No. 270-1401), aluminum case (Radio Shack No. 270-271), IC sockets, 9-volt transistor-radio battery, 9-volt-battery clip, wire, solder, hardware, etching solution (if needed), etc.

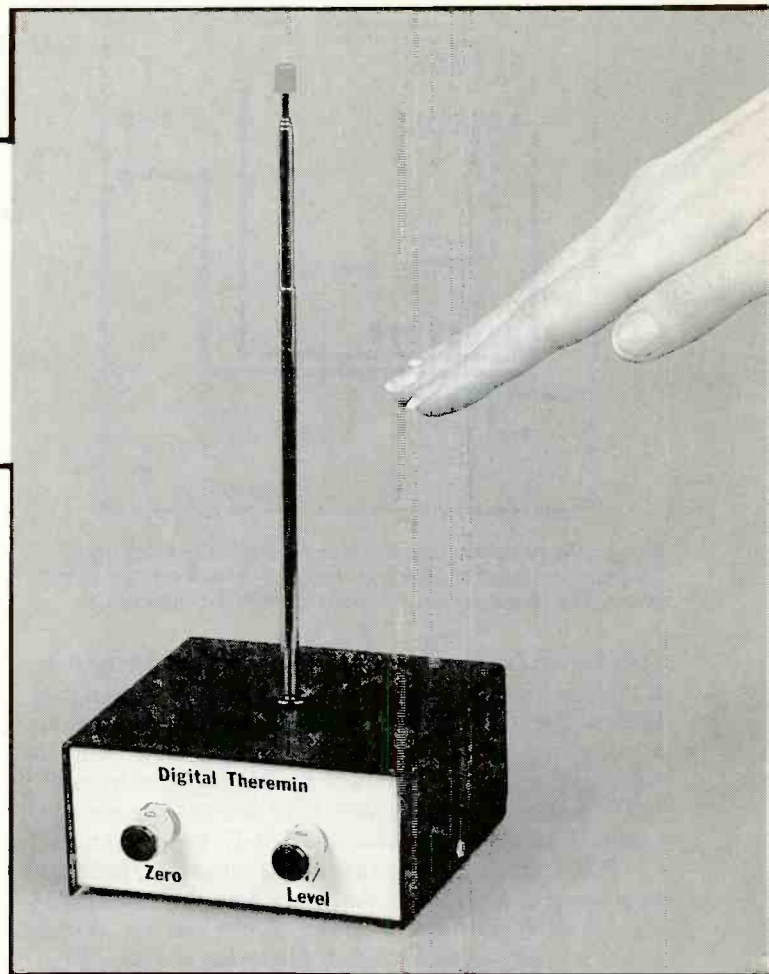

trolled by an on/off switch on the back of R5. Since the 4046 contains a 7.5 V Zener reference diode, it is used for voltage regulation along with R6 for current limiting and bypass capacitor C4.

Putting It Together

The circuit itself is simple, and can be built on a 2 \times 2-in. printed-circuit or perf board. A template for the Digital Theremin's printed-circuit board is shown in Fig. 3, and the

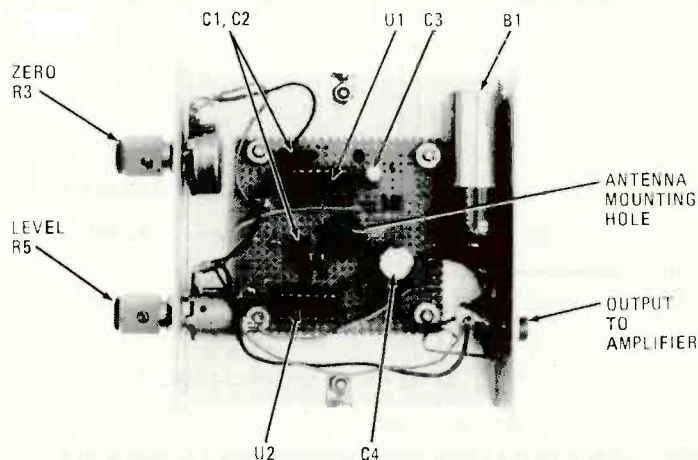

Although a printed-circuit template is provided to make the assembly of the Digital Theremin simple, the author's prototype is shown here mounted on perfboard. You'll note that the layout shown here is similar to the layout that's shown in Fig. 4.

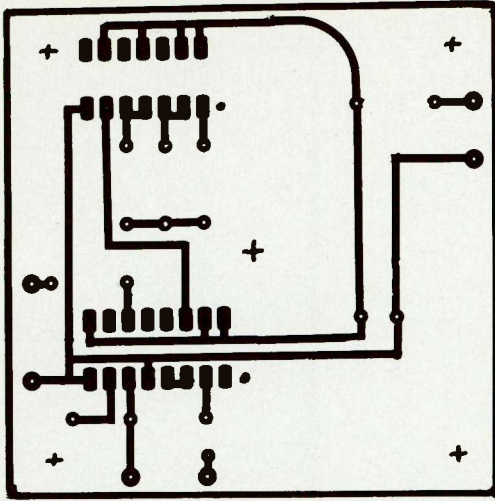

Fig. 3—The full-scale template can be copied or lifted from the page and used to etch your own 2 × 2-inch printed-circuit board. The layout for a printed-circuit board is not critical.

parts layout diagram is shown in Fig. 4. One important detail is that the Theremin should only be built into a metal case, because the metal forms a shield that greatly reduces any tendency for the oscillators to drift in frequency. Using the metal case makes calibration of the theremin much easier.

The author's prototypes were built into an aluminum case sold by Radio Shack (part number 270-271). For best results, C1 and C2 should both be silver mica capacitors, preferably with a tolerance of $\pm 5\%$. And since both chips are CMOS, the use of IC sockets or Molex Soldercons are strongly recommended. Aside from that, the layout and assembly of the board is not critical.

After the board is done, we have to deal with mounting the antenna and connecting it to the board. Since the antenna is covered with a thin layer of chrome, it isn't possible to solder a wire directly to the antenna itself. Included with the antenna used in the project (RS No 270-1401) is a pair of copper washers. Simply solder a short length of wire to one of the washers and secure it to the antenna with a 2-56 machine screw and nut (see Fig. 5).

Mounting the antenna to the board and the case is straightforward if you use several rubber grommets. A grommet with an inside diameter of 1/4-inch will hold the antenna shaft

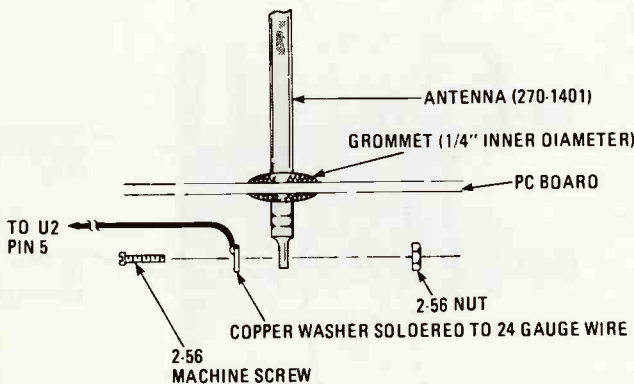

Fig. 5—Because the replacement antenna comes coated with a thin layer of chrome, soldering a wire lead to it won't work. It is therefore necessary to solder the lead to a washer and then use a screw and nut to attach the antenna to the wire. The other end of the wire lead is connected to pin 5 of U2.

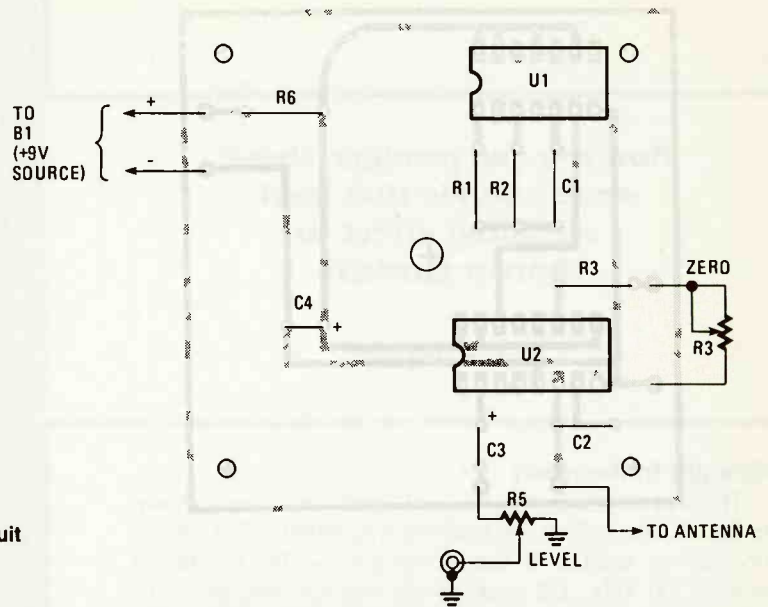
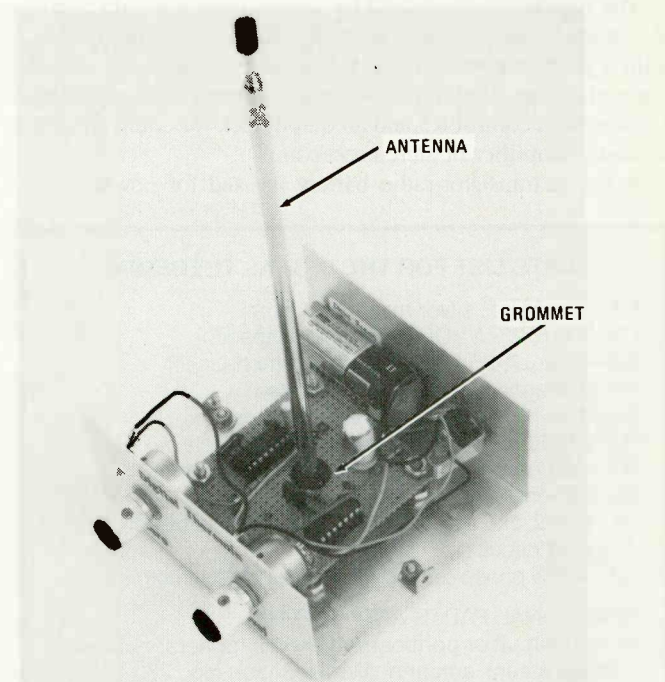

Fig. 4—If you've opted to go the printed-circuit route, this parts placement diagram will make assembly go a lot smoother.

firmly to the board. In the author's prototype, a hole was drilled in the top half of the case so that the top could be removed without disturbing the antenna. By using a slightly larger grommet for the lid, the case was protected from accidental shorts to the antenna, while still being able to be removed easily. A strip of electrical tape or insulating material should be mounted under the board to prevent the antenna from touching the bottom of the case. The printed-circuit board is held by four machine screws to the bottom half of the box, where the controls and the output jack are mounted.

(Continued on page 152)



The antenna, mounted through a hole in the board outfitted with a grommet for a tight and secure fit, is not connected directly to the circuit board. A strip of electrical tape or insulating material mounted under the board prevents the antenna from touching the bottom of the case.

Build a BINAURAL MIKESET



By Thomas Krehbiel

For true, lifelike reproduction, the recording must be binaural rather than stereo. Here's how to make your own binaural mikeset.

□ NO MATTER HOW MUCH WE EQUALIZE, EXPAND, TIME align, or otherwise tweak our stereo systems, the instant we start the music playing our ears tell us that we are hearing reproduced rather than live sounds. Stereophonic reproduction seldom delivers the illusion of reality that it promises. Binaural sound, stereo's often-overlooked first cousin, can come much closer to fooling our hearing; so close in fact, that more often than not, the sound is truly lifelike.

Binaural recordings are made with two microphones that are positioned to simulate a pair of human ears. That is a somewhat different than a stereo recording, which can be made from two mikes in separate rooms. The signals from the binaural mikes are recorded on a standard two-channel (stereo) tape recorder or deck. When the recording is played back through headphones the listener is effectively transported through space and time to where and when the original sound occurred. That happens because the sounds that arrived at the mike's electronic ears are fed directly into the listener's auditory system.

It's an effect that must be experienced to be fully appreciated and understood, but there are very few binaural recordings available commercially. The most practical way to become familiar with the capabilities of binaural reproduction is to make some binaural recordings yourself.

Binaural Microphones

Anyone who owns a stereo tape recorder and a pair of stereo headphones has two out of the three parts that make up a complete binaural recording and reproducing outfit. The third requirement is the binaural microphone set which serves as a surrogate listener.

There are two commercially-produced binaural microphone configurations. In the more common, the microphones are mounted in place of the ears in a dummy head. In the

other, the mikeset takes the form of a pair of headphones which the user places on his or her own head.

A headphone-style mikeset is handy for recording on-the-go, or for obscuring the fact that a recording is being made. (These days, most people take little notice of someone wearing headphones.) The primary problem with having the microphones built into a headset is that their placement changes whenever the wearer moves his or her head. If the wearer turns left the sound will be favored in the right microphone, and vice-versa.

Dummy-head mikesets are generally used in formal recording circumstances because they avoid the unusual effects that may occur when a binaural mikeset changes position during a recording.

Since both kinds of mikesets have their adherents, we'll show how to build both types of binaural mikesets using electret condenser-microphone capsules; the same kind of microphones usually built into portable cassette recorders. Although relatively inexpensive, the capsules are easy to obtain, have good frequency-response characteristics, and require only a simple power supply.

Construction

The first step is to build the power supply. For this you'll need a box large enough to hold a 9-volt battery, a terminal strip, two resistors, and input and output jacks. If you don't have anything suitable lying around the shop, use a Radio Shack model 270-231 Plastic Project Box.

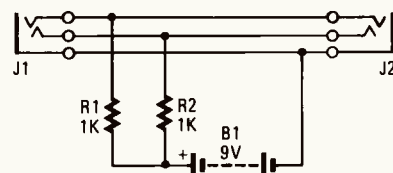

Fig. 1—A 9-volt battery and two resistors are all that are needed for the microphone power supply. Jacks J1 and J2 can be any kind of miniature or standard stereo phone jack.

PARTS LIST FOR BINAURAL MIKESSET

B1—9-volt transistor-radio battery
 J1, J2—Stereo phone jack (see text)
 MIC1, MIC2—Electret microphone capsule, Radio Shack 270-090
 P1—Stereo phone plug (see text)
 R1, R2—1000-ohm, ¼-watt, resistor
 Misc.—Styrofoam wig stand or miniature stereo headset (or both), battery holder, plastic project box, two-lug terminal strip, miniature shielded cable, hookup wire

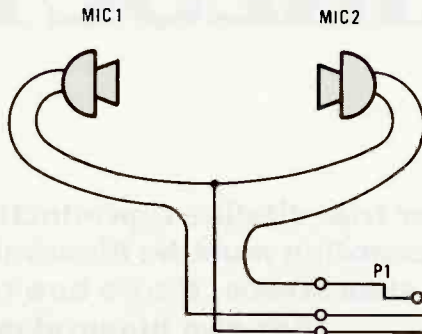
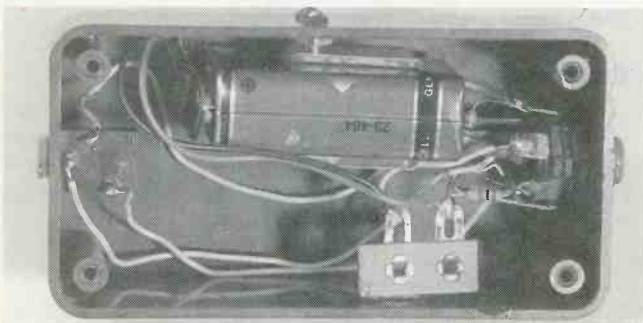

Fig. 2—Whether the microphones are installed in a headset or a dummy head, the wiring is the same. Make certain the common connection is wired to P1's sleeve.

Start by drilling appropriate holes in each end and then mount the input and output jacks. I used three-conductor phone jacks, one miniature and the other standard-sized, because that's what I had in stock. It really makes no difference whether standard or miniature jacks are used.

Mount a battery holder and a 2-lug terminal strip along the sides of the box. Connect the red wire from a battery clip to one of the terminal lugs; then connect one end of resistors R1 and R2 to that same lug. The other ends of the resistors go to the signal-carrying contacts of one of the jacks. It doesn't matter which one; use whichever one is easier to reach.

The black battery wire goes to the remaining terminal strip lug, and a length of wire runs from there to either J1 or J2's grounding lug. Next, run three wires from each of the lugs of one jack to the corresponding lugs of the other and solder all connections. Clip a 9-volt battery in place and close up the box.



Nothing is critical about the power supply; use any layout and any kind of suitable cabinet. The two-lug terminal strip serves only as a power source for the resistors.

There is no need for an on-off switch since the battery is disconnected when nothing is plugged into either jack.

It is also not necessary to identify one jack as *input* and the other as *output* because the power module is symmetrical.

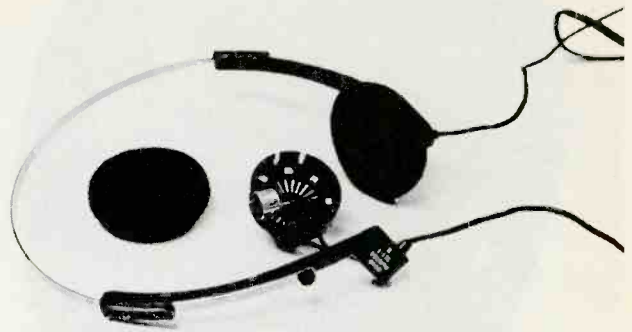

A microphone capsule fits neatly into the space that's left when the speaker element is removed from the earpiece of a miniature (lightweight) stereo headset.

Either jack may be used for the mikeset: the remaining jack connects to the recorder.

Installing the Capsules

(Note, the parts values shown are those required by the Radio Shack capsule given in the parts list. Other microphone capsules may require additional parts, different resistor values, or different battery polarity. If you substitute for the recommended capsule, be sure to follow its manufacturer's recommendations.)

Now you're ready to mount and wire the microphone capsules. To make the dummy-head version, you'll need a plastic-foam wig head to hold the mikes. A new one is fine, but you can find serviceable used heads at many thrift and second-hand stores at very low prices. A coat of flat-black spray paint gives a fresh appearance and covers minor scrapes.

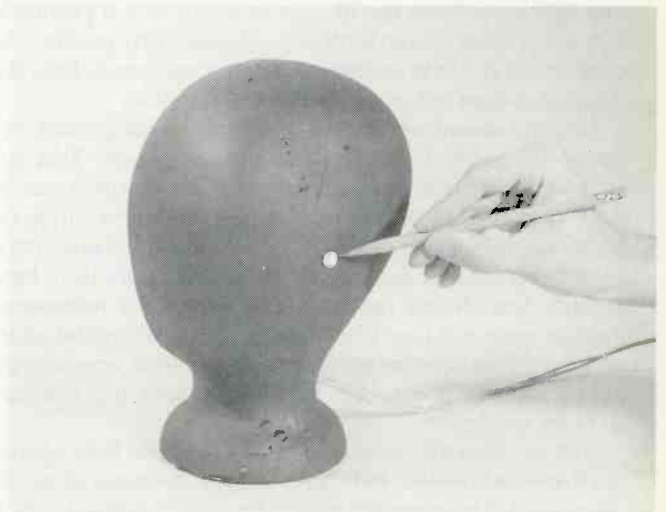

The white dot pointed to by the pencil is actually one of the small electret microphones which is mounted on the sides of the dummy head. A corresponding microphone is mounted on the opposite side of the foam form.

To prepare the wig head to receive the mikes, start by using a ¼-in. twist-drill bit to ream holes at ear level on both sides of the head. Do this by hand. If you make the holes just a bit smaller than the microphone capsules the capsules will be held in place securely without adhesives (by friction).

Solder a suitable length of flexible shielded cable to each of the capsules. Be sure to observe polarity.

(Continued on page 161)

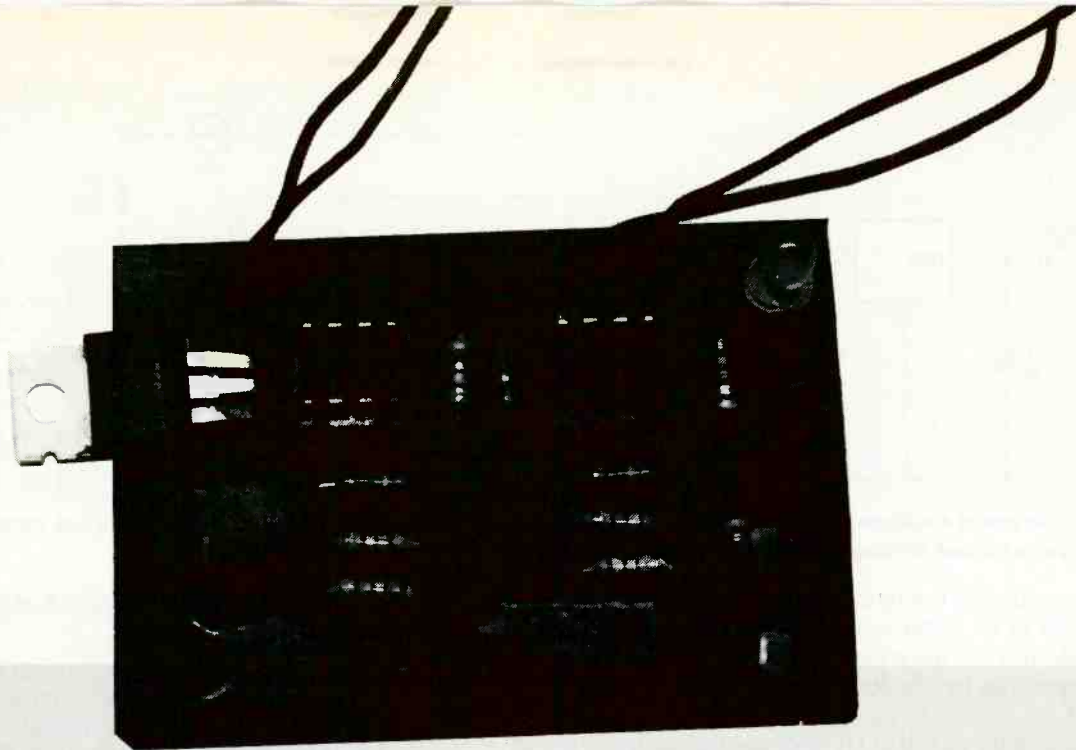

THE TEST-A-MATIC

**If you're hung-up on telephone-cable sorting,
then here's a project guaranteed to ring your bell!**

By Bob Grossblatt

□ ONCE UPON A TIME, THE ONE THING YOU DIDN'T DO WAS to mess around with the phone company—no matter what. All the telephone stuff in your house was only there temporarily. The phones, cable, even your number, was rented from Ma Bell. You were allowed to use it; but if they caught you just looking at it with a screwdriver in your hand, you had a good chance of losing your contact with the outside world.

A Brave New World

Well, things have changed. Extension cables, extra phones, modems, and a huge aftermarket of telephone add-ons, have been created as a result of forced divestiture and other legislation. As things stand now, the phone company will provide you with a line, a number, and permission to hang just about anything you want on the telephone outlet. The days of expensive buffer boxes and protective adapters are over. After 50 years, Ma Bell has finally realized that even if you plug the phone line into a 117-volt AC socket, the only damage will be to yourself.

Even though a whole slew of new standards have emerged for wire, plugs, and jacks, it's still necessary to ring out the lines and be sure of maintaining correct polarity. The former is important when you're running several lines together; and the latter is needed if the accessories you're connecting draw operating power directly from the phone line.

What Is Needed?

With new things to test, you can well expect new test equipment to be born. For the new need, the Test-A-Matic

was designed and made to *ring out* the telephone lines you install in your home, office, and shop. The Test-A-Matic is, among other things, nothing fancy. None of the parts are the least bit exotic, the layout isn't critical, and you can use any construction method you like. The circuit will work just as well if it's neatly laid out on a printed-circuit board or spread all over the room with alligator clips. But before we get into the circuit itself, let's take a look at what it will do for you.

There are two basic line tests that you can perform with the Test-A-Matic—line identification and polarity test. The line tester will actually do double duty, since it will indicate continuity. Checking the integrity of the copper is only half the job; you have to watch the polarity as well. In the old days of rotary dials, polarity wasn't a big deal—but DTMF phones are powered off the phone line and won't work unless you maintain the proper polarity. The Test-A-Matic is an easy and convenient way to make sure that you've wired everything properly before you actually connect any equipment to the line.

Operation

The complete schematic diagram is shown in Fig. 1. If you're already familiar with the 555, you won't have any trouble understanding how the circuit works. Both the 555's are set up as astable timers, and U1 is used to modulate the frequency of U2. Resistors R3 and R4, and capacitor C3 are chosen to generate a frequency of about 4 Hz for U1. The low frequency of U2 (determined mathematically by the values of R7, R8, and C4) is about 733 Hz; but the measured frequency

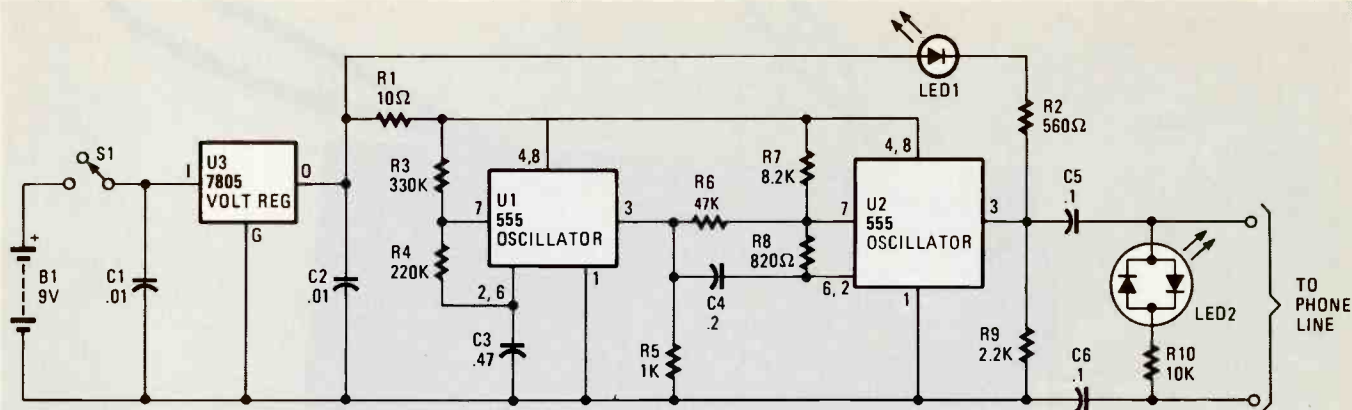

Fig. 1—If the use of a voltage regulator seems a bit drastic to you, try using a Zener diode rated close to five volts in parallel to the circuit, and a current-limiting resistor in series with the battery.

is higher, since the timing capacitor (C4) is set to discharge to the output of U1 rather than ground. Without going through the math, that has the effect of changing both U2's high and low frequencies by a factor related to the duty cycle of U1—about 3.

By having the output of U1 modulate the discharge threshold of U2, the output frequency of the Test-A-Matic will switch back and forth between approximately 710 and 2100 Hz at a 4-Hz rate. The result of all that is a very distinctive signal that can be easily identified when you're trying to ring out lines. Light-emitting diode LED1 is really only in the circuit to show that it's working. (If there's no speaker on the line, it's nice to be able to have an indication that the unit is working.)

The Test-A-Matic uses two separate 555's but you can cut down on the number of parts by replacing both of them with one 556 dual timer. All the rest of the components will remain the same. The circuit has to be powered by 5 volts; and one way to do it is, as shown in the schematic diagram (Fig. 1), by feeding a 7805 regulator chip with a nine-volt battery. When the circuit is operating it will draw about 100 milliamperes. That is much too much current to get directly from the phone line. If you want to power the Test-A-Matic from the phone line, replace the two 555's with 7555's, the CMOS version of the chips. That will cut the amount of operating current down to a maximum of about 15 millamps—well within the phone line's capacity.

PARTS LIST FOR THE TEST-A-MATIC

SEMICONDUCTORS

LED1—Light-emitting diode, jumbo red
 LED2—Light-emitting diode, tri-color
 U1—7805 5-volt regulator, integrated circuit
 U2, U3—555 timer integrated circuit

CAPACITORS

C1, C2—.01-μF, ceramic disc
 C3—.47-μF, Mylar
 C4—.2-μF, ceramic disc
 C5, C6—.1-μF, ceramic disc

RESISTORS

(All resistors are ¼ watt, 10% units.)

R1—10-ohm
 R2—560-ohm
 R3—330,000-ohm
 R4—220,000-ohm
 R5—1000-ohm
 R6—47,000-ohm
 R7—8200-ohm
 R8—820-ohm
 R9—2200-ohm
 R10—10,000-ohm

ADDITIONAL PARTS AND MATERIALS

S1—SPST, slide or toggle switch
 B1—9-volt, transistor-radio battery
 Battery clip, hookup wire, alligator clips, modular plug (see text), solder, etc.

While it may seem slicker to have the Test-A-Matic line powered, it turns out to be less than terrific in actual practice. By building the unit as shown, you can use it for things other than phone lines. As a matter of fact, it's nice to be able to ring out lines *before* they're tied into an active phone line.

Using tri-colored light-emitting diodes (LED2) is a handy way to make sure that the polarity of the phone line is correct. Since it's connected in the circuit after the two decoupling capacitors C5 and C6, it will be powered only by the voltage on the phone line. That means the Test-A-Matic can be turned off and you'll still be able to check line polarity.

Construction

When you assemble the Test-A-Matic, you should make sure that the tri-color light-emitting diode, LED2, is wired to be green when the polarity is correct and red when it's reversed. That isn't a hard and fast rule, but it's a lot easier to remember that green means correct, or "go." The easiest way

(Continued on page 153)

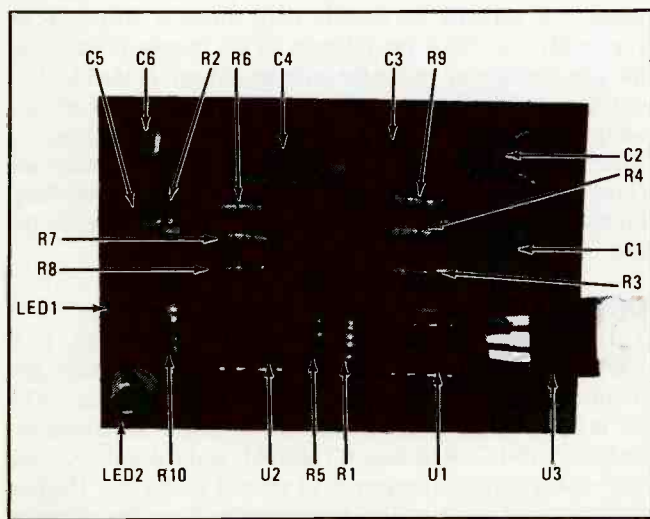

Parts location for the Test-A-Matic layout used by the author.



DIGITAL LOGIC PROBE

When you need to quickly check the input or output status of logic gates, a digital logic probe can save you lots of wasted energy.

□ NO ONE CAN DISPUTE THE USEFULNESS of a logic probe in detecting malfunctioning logic gates or other chips. "Why," you might ask, "do I need a logic probe?" Well, if you've been following the articles that appear here monthly, the answer would be agonizingly clear. Take, for instance, this scenario: You've just finished assembling a digital capacitance meter from a magazine article. You've conscientiously checked your work, looking for cold solder joints, solder bridges, mis-oriented components, and the like.

Confident of the integrity of your work, you crank the circuit up, only to find that *the darn thing doesn't work!* Your first thought is to call or write to the magazine and give them a piece of your mind, but you soon realize that that won't remedy the situation. So here you are....out \$35 to \$40 for parts and other supplies that you've purchased to complete this project.

Not one to say die, you venture into the mysterious logic labyrinth, armed only with your trusty digital multimeter. You check the power supply for the correct voltage and various pins (as best you can) of the IC's...all seems just fine. But, the circuit still doesn't work and you can't figure out why. It's times like those that you sure could use a logic checker, such as Tektron's *Digital Logic Probe*. The probe comes in kit form and is available from the

supplier given in the Parts List. While many such probes are commercially available ready-built, it's much more informative to build one yourself.

Circuit Operation

Figure 1 shows a schematic diagram of the Digital Logic Probe. The circuit, consisting of two chips—an LM324 quad op-amp, and a 4013 dual, D-type flip-flop—and a handful of assorted support components provides both logic-level indication and pulse detection. The Digital Logic Probe doesn't require its own power supply; instead it relies on the power supply of the CUT (Circuit-Under-Test).

The input to the probe (at probe tip) is fed along two paths: one flowing to the clock inputs of U2a and U2b; and the other feeding both the inverting input of U1c (which is set up as an inverting-mode integrator) and the non-inverting input of U1b (which is configured as a non-inverting unity-gain amplifier).

Through wire clip-leads connected to the points labeled V_{CC} and GND in Fig. 1, V_{CC} is applied to the active elements of the circuit and—via R1, and R2, as a reference voltage—to pin 10 of U1c. Now let's say, for example, that the probe is connected in a live circuit and the probe tip is touched to an output pin. Let's further surmise that that particular output is in a logic-low state.

That low, being below the reference set at pin 10, causes U1b's output (at pin 7) to go high. At the same time, that low is fed to pin 5 of U1b, which (because of its configuration) provides a low output at pin 8. LED1 and LED2 are connected in parallel with, and opposite in polarity to, each other across the outputs of U1b and U1c. With U1b outputting a low and U1c outputting a high, LED1 is forward biased and lights. LED2, being reverse-biased, remains dark.

Now let's suppose that the logic level on the same pin goes high. That high is applied to pin 5 of U1b, causing its output to be high. At the same time, that high (applied to pin 9) causes the output of U1c at pin 8 to go low (the inverting effect of its configuration). With U1b outputting a high and U1c outputting a low, LED2 is now forward-biased and lights, while LED1 is reverse-biased and goes dark.

The bias that's applied to pin 10 of U1c is also applied to pin 12 of U1d (which is configured in the inverting mode). Thus far, the pulse-detection lamp, LED3, has remained dark, because the first logic level sensed, a low, had no effect on the state of the flip-flop outputs. The second logic level that was sensed, a high, forces the \bar{Q} output of both flip-flops high, reverse-biasing both D2 and D3, which causes the output of U1d to be low, once again keeping LED3 off.

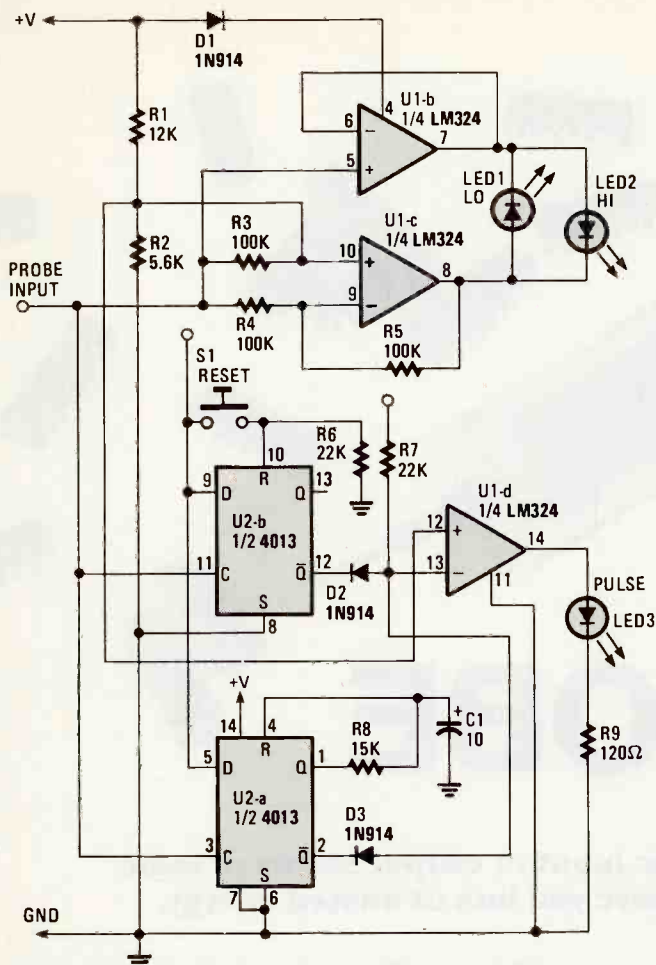

Fig. 1—The Digital Logic Probe, consisting of two chips—an LM324 quad op-amp, and a 4013 dual D-type flip-flop—and a handful of other assorted components, provides both logic-level indication and pulse detection. Its input is fed along two paths: one flowing to the clock inputs of U2a and U2b; and the other feeding both the inverting input of U1c and the non-inverting input of U1b. Because of the configurations of U1b and U1c, their outputs are always opposite in polarity to each other, causing either LED1 or LED2 to light.

Now, let's assume that a clock frequency is sensed at the probe input; LED1 and LED2 alternately light and, depending on the frequency of the signal, may appear constantly lit. That frequency, which is also applied to the clock input of both flip-flops, causes the \bar{Q} outputs of U2a and U2b to simultaneously alternate between high and low. Each time that the \bar{Q} outputs of the two flip-flops go low, the output of U1d is forced high, lighting LED3, indicating that a pulse stream has been detected.

Probe Assembly

The Digital Logic Probe is assembled on a printed-circuit board measuring 5-inches long and 3/4-inch wide. (The following instructions assume that you've purchased the kit from the supplier given in the Parts List, but they generally apply to all electronics construction.) Because of the tight spacing of the printed-circuit traces, extreme care must be taken during

component installation and soldering.

Using a low-wattage soldering iron, place and solder the passive components—resistors, capacitors—one at a time, checking for cold-solder joints, solder bridges, and misoriented components as you progress. Thus far, the only polarity-dependent components that you need worry about are two electrolytic capacitors.

Once all passive components have been installed, move on to the semiconductors, starting with the diodes (applying only enough heat to make a good solder joint, but not enough to toast the diode), checking the component's orientation prior to soldering—and for cold solder joints and solder bridges after soldering—the component in place. After that, install and solder the integrated circuits and LED's.

Next attach a red-jacketed (+) and black-jacketed (-) alligator clip lead, via insulated wire, to the appropriate points on the printed-circuit board. S1 has a

PARTS LIST FOR THE DIGITAL LOGIC PROBE

- (All resistors are 1/4 watt, 5% units.)
 C1—10µF, 16-WVDC electrolytic capacitor
 D1—D3—1N914 general-purpose, small-signal, silicon diode
 LED1—LED3—Jumbo red light-emitting diode
 R1—12,000-ohm resistor
 R2—5600-ohm resistor
 R3—R5—100,000-ohm resistor
 R6, R7—22,000-ohm resistor
 R8—15,000-ohm resistor
 R9—120-ohm resistor
 S1—Normally-open pushbutton switch
 U1—LM324 quad op-amp, integrated circuit
 U2—4013 dual, D-type flip-flop, integrated circuit
 Printed-circuit or perfboard materials, probe tip, length of twin-lead, alligator clips (red and black jackets), 3/4-inch clear acrylic tubing, hardware, solder, wire, etc.
Note: A complete kit of parts for the Digital Logic Probe is available from Tektron Equipment Corp., 230 Arvin Ave., Stoney Creek, Ontario, Canada, L8E 2L8 (Tel. 416/662-7820) priced at \$15.00 (including shipping and handling).

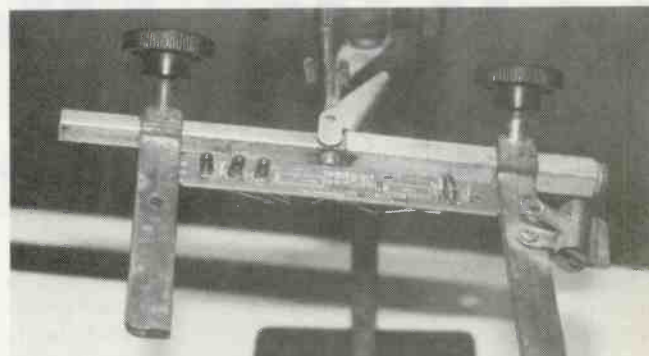

Using a low-wattage soldering iron install and solder all components to the printed-circuit board, beginning with the passive components, then moving on to the semiconductors—diodes and ICs first (applying only enough heat to make a good solder joint, but not enough to toast the diode). Afterward, install and solder the LEDs and integrated circuits.

somewhat unusual installation; instead of having its leads placed through holes in the board and soldered, the leads are first placed through the circuit-board supports and are then tack soldered to the end of the board where the clip leads are attached. To the other end of the board, mount the probe tip (as shown in Fig. 2), making sure that the printed-circuit board fits snugly into the groove in the PC-board separator.

Checkout and Use

With all of the assembly accomplished, check your work, being mindful of solder bridges, cold-solder joints, misoriented components, etc. Temporarily insert the probe's printed-circuit board into a length of acrylic tubing (about 3/4-inch inner diameter cut to about 5-inches long). Connect the power (red and black) leads to a live digital circuit, observing the proper polarity.

(Continued on page 154)

The coming generation...

FRIENDLY ROBOTS

By Harry Nelson

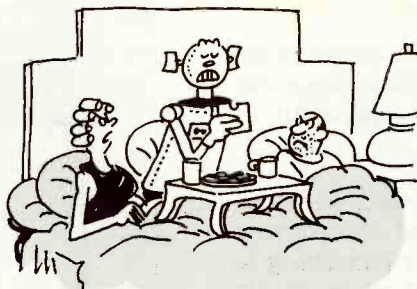

"When I said, 'We'll have breakfast in bed,' I meant my husband and me!"

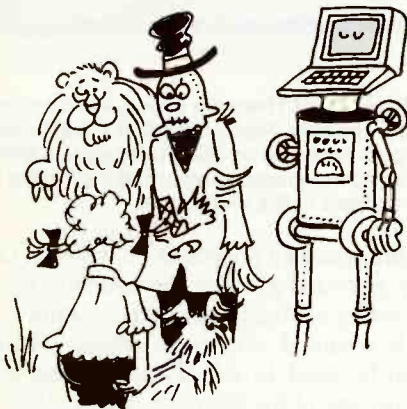

"You better ask the Tin Man, Dotty. He's the smart one!"



"Officer, Xyman is okay! It's my wife that's run amok."

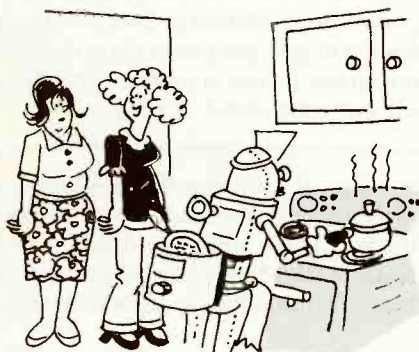

"Here's Shelli. Her specialty is anything that's deep fried."

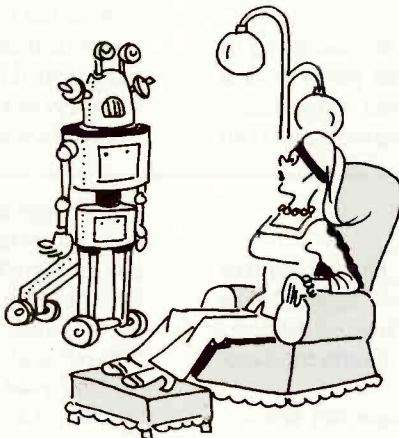

"Beep...I cannot answer the door, madam. It does not speak."



"Besides serving drinks, XDO-4 has an attachment to cut grass."



"It was you who told Robbo to wash the car and to use a bucket!"

Australia's
Dick Smith
is alive
and well
in Indiana



now available!

THIS MONTH'S GIANT ELECTRONICS CATALOG

The Dick Smith Electronics Catalog is the fun way to find the electronic things you need. Our new monthly Catalog is bigger - 192 pages crammed full of the things the other guys don't offer - and better - with more of our exclusive data pages including the new "feed back" section that invites your participation. The ever-growing DSE Catalog is as dynamic as Dick himself with a brand new issue each month to keep you up-to-date. Join the fun! Send us your name, address, and \$2 for this month's Dick Smith Electronics Catalog today!

BRUCE TUNNY, Catalog Subscriptions
P.O. BOX 468, GREENWOOD, IN 46142
Phone 317-888-7265 - Fax 317-888-7368

DICK SMITH ELECTRONICS

CIRCLE 19 ON FREE INFORMATION CARD

AMAZING SCIENTIFIC & ELECTRONIC PRODUCTS

PLANS

Build Yourself - All Parts Available in Stock

LC7 - BURNING CUTTING CO ₂ LASER	\$20.00
RUB4 - PORTABLE LASER RAY PISTOL	\$20.00
TCC1 - 3 SEPARATE TESLA COIL PLANS TO 1.5 MEV	\$25.00
IOG1 - ION RAY GUN	\$10.00
GRA1 - GRAVITY GENERATOR	\$10.00
EML1 - ELECTRO MAGNET COIL GUN/LAUNCHER	\$8.00

KITS

With All Necessary Plans

MFT3K - FM VOICE TRANSMITTER 3 MI RANGE	\$49.50
VWPM7K - TELEPHONE TRANSMITTER 3 MI RANGE	\$39.50
BTC3K - 250,000 VOLT 10-14" SPARK TESLA COIL	\$249.50
LHC2K - SIMULATED MULTICOLOR LASER	\$44.50
BLS1K - 100,000 WATT BLASTER DEFENSE DEVICE	\$69.50
ITM1K - 100,000 VOLT 20" AFFECTIVE RANGE INTIMIDATOR	\$69.50
PSP4K - TIME VARIANT SHOCK WAVE PISTOL	\$59.50
STAK - ALL NEW SPACE AGE ACTIVE PLASMA SABER	\$59.50
MVP1K - SEE IN DARK KIT	\$199.50
PTG1K - SPECTACULAR PLASMA TORNADO GENERATOR	\$149.50

ASSEMBLED

With All Necessary Instructions

BTC10 - 50,000 VOLT-WORLD'S SMALLEST TESLA COIL	\$54.50
LGU40 - 1MW HeNe VISIBLE RED LASER GUN	\$249.50
TAT30 - AUTO TELEPHONE RECORDING DEVICE	\$24.50
GVPI0 - SEE IN TOTAL DARKNESS IR VIEWER	\$349.50
LIS10 - SNOOPER PHONE INFINITY TRANSMITTER	\$169.50
IPG70 - INVISIBLE PAIN FIELD GENERATOR MULTI MODE	\$74.50

• CATALOG CONTAINING DESCRIPTIONS OF ABOVE PLUS HUNDREDS MORE AVAILABLE FOR \$1.00 OR USE OUR PHONE FOR "ORDERS ONLY" 603-673-4730.

PLEASE INCLUDE \$3.00 PH ON ALL KITS AND PRODUCTS PLANS ARE POST/AGE PAID. SEND CHECK, MO, VISA, MC IN US FUNDS.

INFORMATION UNLIMITED
P.O. BOX 716 DEPT. HO AMHERST, NH 03031

CIRCLE 18 ON FREE INFORMATION CARD

DIGITAL THEREMIN

(Continued from page 144)

Finally, be sure to scrape the paint out of the insides of the screw holes in the top of the case so that the shielding works on both halves. (An Xacto knife or reamer works well.)

Testing and Calibration

After assembly is complete, carefully inspect the Theremin for wiring errors, poor solder joints, and other potential problems. If everything looks good, hook the Theremin up to a receiver or audio amplifier with a patchcord, attach a battery to the clip, and apply power.

Slowly raise the volume using the LEVEL control. If all is well, a high-pitched squeal should be heard. Waving a hand near the antenna should cause the pitch to raise. Extend the antenna to its full length and adjust the ZERO control knob for a spot where no sound is heard unless your hand comes near the antenna. If the squeal does not *tune out* at any point, shorten the antenna length by a few inches and try again. When set properly, the Theremin will remain silent until the performer moves his or her hands to within several inches of the antenna shaft.

There are many factors that can influence the capacitance of the human body, and all of them can affect the Theremin's operation. Things like the antenna length, air humidity, the size, and dress of the performer, and the thickness of the user's shoe sole (and the color of the socks worn, no doubt) can all interact to necessitate a change in the ZERO control setting. With a little practice, the ZERO control can be correctly set in a few seconds.

Finally, the Theremin should be given a few moments to stabilize due to temperature change after the power is first turned on. If the Theremin is powered up and immediately zeroed, it will be sure to drift and need calibration again (and



This frontal view of the Digital Theremin shows the location of the panel-mounted controls. Also notice that the antenna, beside going through a grommet on the printed-circuit board, protrudes through a second grommet mounted top-center of the enclosure, lending support to the installation.

again). The best cure is to turn the power on with the LEVEL control all the way down and give the Theremin five minutes or so to warm up before calibrating the ZERO control.

The Theremin is a natural with audio special effects. A volume pedal can be used to add dynamics and create fadeouts, and almost any of the floor boxes for guitarists or synthesizers will change some aspect of the sound quality. The ethereal sound of the Theremin works very well with echo and delay effects.

Whether the Theremin is used as a special effect for rock bands or theater groups, or to enhance your next Halloween party, you'll find that it will give you plenty of unusual sound for a very modest investment in time or money. Not only is the Theremin interesting and educational, it's fun! ■

TIME CAPSUL

(Continued from page 116)

unknown capacitor across the binding posts, being careful to observe polarity. The unit will have started clicking audibly as soon as you've turned on the power switch. Now, on the beat, depress Test Switch S2. The LED will light. Count the beats until LED1 extinguishes.

For example, say you have a fairly large capacitor and you

are in doubt about its value. If you follow the above procedure and LED1 stays lighted for only a second or two, switch the Range Switch to the next lower range and depress the Test Switch again. If the LED stays lighted for 20 beats and you are set to the $\times 10$ range, it means the capacitor under test is a 200- μ F unit.

Trust your Time CapsUL to transport your old, unmarked capacitors to a useful and productive future. ■

PARTS LIST FOR THE TIME CAPSUL

SEMICONDUCTORS

U1, U2—555 timer IC
LED1—Jumbo red LED

CAPACITORS

(Capacitors are rated at 15 WVDC unless otherwise indicated.)

C1, C3—0.1 μ F ceramic disc, 35 WVDC
C2—100- μ F electrolytic
C4—1.2- μ F tantalum
C5—50- μ F electrolytic
C6—25- μ F electrolytic

RESISTORS

(All fixed resistors are 10%, 1/2-watt units)
R1—100,000-ohm
R2—560-ohm
R3—910,000-ohm
R4—91,000-ohm

R5—9100-ohm
R6—680-ohm
R7—150-ohm
R8—1-Megohm miniature trimmer potentiometer (see text)

ADDITIONAL PARTS AND MATERIALS

B1, B2—9-volt, transistor-radio batteries
BP1, BP2—Multi-way binding posts (one red, one black)
SPKR1—Miniature speaker (see text)
S1—Single pole, 3-position rotary switch (SP3P)
S2—Normally-open, momentary-contact pushbutton switch
S3—Double-pole double-throw (DPDT) switch; either toggle, slide, or push-on push-off (such as Radio Shack 275-1553)
LED Panel lamp holder, Radio Shack 276-080; cabinet, Radio Shack 270-627; battery clips, perf board, solder, wire, etc.

SOLAR POWERED HOUSE NUMBER

(Continued from page 112)

panel is installed with the correct polarity. If the lead-acid cells are heavily discharged, it may be advantageous to leave them charging for a few days before connecting them to the rest of the circuit. Otherwise, the circuit is ready for permanent installation.

Installation

The solar-cell array should be mounted on the roof of your house and tilted towards true north to ensure maximum solar illumination. Make sure that you choose a spot that will not be shaded by trees or other objects at any time during the day. If the solar cells are shaded, their output will be drastically reduced and the panel may not recharge the batteries.

Note that the optimum angle of inclination of the cells varies according to the latitude of your town or city. That needn't be exact, as a few degrees either way won't make all

THE TEST-A-MATIC

(Continued on page 148)

to identify the positive side of the phone line is with a voltmeter set to a scale capable of measuring at least 50 volts. Once you're sure which is the plus side of the line, connect the tri-color LED. If it lights green, you're in business; if it's red, just flip it.

It may seem to you that R10 is a bit large for a current-limiting resistor, but remember that there's 50 volts on the line. Making R10 smaller won't increase the output of the tri-color LED, but may lower the line voltage enough to trigger an off-hook condition. That will drop the line voltage to about 5 volts. It's nothing to worry about—but since it's avoidable, why not bother?

Building the Test-A-Matic is even easier than using it. Nothing is critical and you can use any method you prefer. If you want to change any of the frequencies, use the standard 555 formulas to work out new values to alter either the warble rate or frequency. Just remember that the former is set by U1 and the latter by U2. There are some components you should leave alone. R1 holds the operating current at about 100 milliamps and R9 provides U2 with a resistive load to make sure that the circuit will always start.

Ringing the House Down

Once you have the Test-A-Matic up and operating, clip it onto the phone line and turn it on. LED1 should be pulsing on and off and LED2 should be either red or green. If it's not working, check your circuit connections, make sure there's power going to the 555's, and so on. Because the circuit is so simple, possible problems are simple as well.

There's only one *no-no*, but it's an important one. Although 555's can operate over a wide range of supply voltages, the Test-A-Matic is designed to work properly with a 5-volt supply. You won't blow anything up if you feed it 9 volts—but it won't work, either. It's very important to use U3, the 7805. If the circuit is powered by anything more than 5 volts, it's operation will be erratic at best. Not only that, but you'll have trouble trying to figure out what's wrong.

Using the Test-A-Matic is straightforward. Just clip the leads to the line and turn it on. The warble produced has a lot of *oomph* behind it and, because of its distinctive sound, you'll be able to recognize it easily at the other end of the line.

TABLE 2—OPTIMUM INCLINATION FOR SOLAR-CELL ARRAY

San Francisco, CA	42°
Los Angeles, CA	38°
Dallas, TX	37°
Chicago, IL	47°
New York, NY	45°
Washington, DC	43°
Miami, FL	30°
New Orleans, LA	34°
Tacoma, WA	51°
Montreal, Canada	50°
Quebec, Canada	51°
Vancouver, Canada	53°

that much difference. Table 2 lists the optimum angle of inclination for various U.S. and Canadian cities.

Perhaps the best way of mounting the solar-cell panel is to attach it to the top of the TV antenna mast. The leads can then be run down the mast, adjacent to the antenna lead-in, and routed to the control unit. ■

If you're using it to ring out live phone lines, the tri-color LED will immediately show you if you have the proper polarity. The only addition that you might want to make to the circuit is to parallel another cable with the test leads. It's sometimes handy to have the Test-A-Matic's output connected to a modular connector so that you can easily plug it into a telephone wall outlet.

A Word to the Wise

A word of warning is in order: It only takes one break in the standard to throw the conventions out the window. It often happens that someone (even a phone-company installer), won't pay attention to the red and green standards so your modular pigtail won't give a true indication of the line. When in doubt, use the clip leads.

It doesn't take much in the way of time, energy, or money to put a Test-A-Matic together. You should be able to knock one off in a few hours without spending more than a couple of bucks. The amount of brain damage it can save you, however, is beyond measure. Take a little bit of time and build one. If you only use it once a year, it will be more than worth the effort. ■

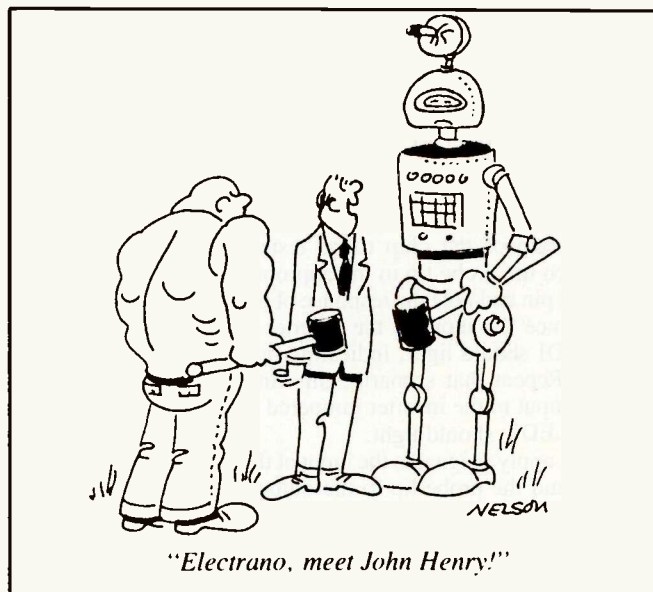

ONE SHOT SHOOTING

(Continued from page 141)

ator. A resistor connected momentarily from the base of Q7 to plus 3–4½ volts should cause the lamp to light. If it doesn't, check the diode to see that the band end (the cathode) goes to the amp. Be sure that the + side of C4 goes to the switch and R8 (39,000 ohms).

The target in Fig. 3 may be laid out on a piece of perboard just about the way it is drawn. That makes it easier to check out. Start with Q5, Q6, and the LED. Touch a resistor (1000- to 10,000-ohms) to the base of Q5 and the battery plus. The LED should light, and if you have it in the circuit, the sounder should also tell you that that part of the system is go. If you are not sure about the leads on the LED, connect about 470–1000 ohms to one side of it and the battery. If it doesn't light reverse the connections to the battery. If it still fails to light try another LED.

To check Q4 and the pulse stretcher, touch a resistor, about 100–1000 ohms, from the base of Q4 to its emitter. The LED and sounder should fire and fade out about a second or so after you remove resistor.

You may check Q3 by firing a light burst right into its input. If you get no response, try a small resistor (100–1000 ohms) momentarily across Q3. If that works check the emitter/ collector connections to Q3, they are probably reversed. A photoconductive cell will work with the leads connected either way.

Checking the Synthesizer

The target in Fig. 4 checks out about the same way; it just has a few more parts. You can turn on Q15–Q16 the synthesizer, and Q17–Q18 the speaker amplifier by touching a small resistor from battery plus to either R19 or R20. If you want to check Q17–Q18 by themselves, use at least a 15,000-ohm resistor from the base of Q17 to battery (power supply)

plus. Make and break the connection rapidly, that will produce loud clicks in the speaker.

The pilot light in Fig. 6 should run if the LED is good. The pilot light uses a basic building block, a multivibrator. With minor modifications it can be used as a music synthesizer. Another popular building block, the Darlington pair serves as the heart of the One Shot, the Outer Space model, and the switches in the targets. Feel free to experiment with those circuits and make your own applications of them.

When all systems are "GO," put the covers on them and your shooting gallery is ready to blast those rainy-day dol-drums into so much cosmic vapor. ■

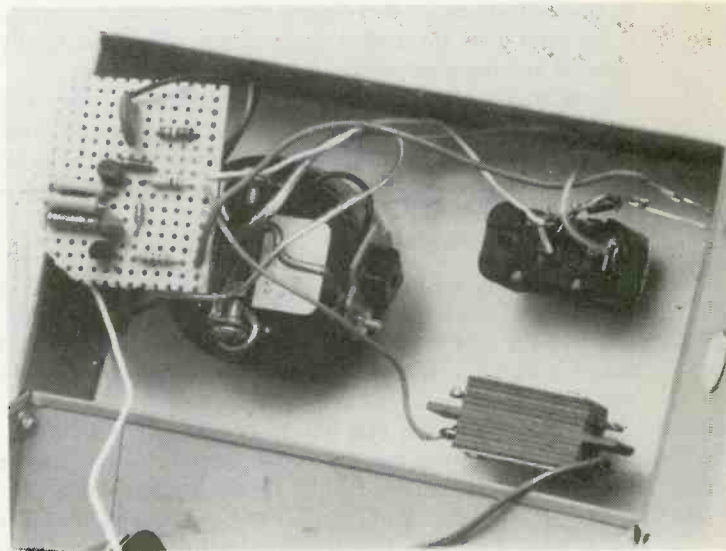

When connecting the panel-mounted components to the board, be sure that the starting and termination points coincide with the schematic diagram.

DIGITAL LOGIC PROBE

(Continued from page 150)

If you don't have a ready-built circuit that you can play with, but you do have a solderless breadboard, DC power supply handy, and some sort of TTL/CMOS-level signal source (preferably a function generator), and of course a logic chip, you can rig a test circuit with a predictable output.

Assuming that you've opted to rig a test circuit, apply power to the circuit, and place a jumper from the positive power source to the input of an inverter (or two inputs to a NAND gate), referring to a pin-out diagram of the chip to be tested. Then touch the probe tip to the appropriate output pin and note the response of the LEDs. Since the input to the inverter is high, LED1 should light, indicating output low. Repeat that scenario, this time with the input to the inverter jumpered to ground; LED2 should light.

Finally, apply a signal to the input of the inverter, and the probe tip to the output. LED1 and LED2 should alternately turn off and on (or may appear continually lit), while LED3 toggles on and off in time with the signal frequency. ■

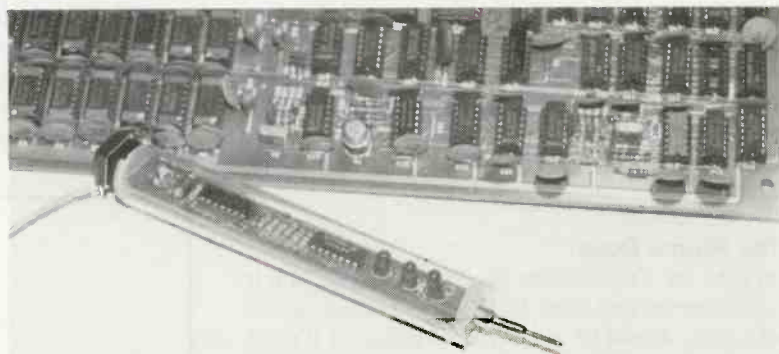

Connect the power (red and black) leads to a digital circuit, observing the proper polarity. Apply power to the circuit, and (referring to a pinout of the chip) touch the probe tip to an output pin and note the response of the LEDs.

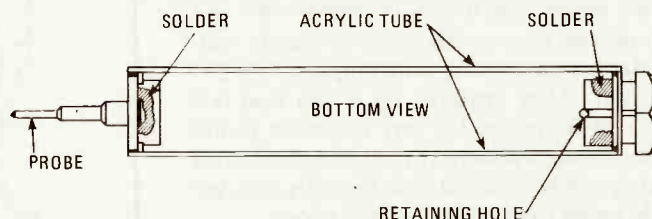

Fig. 2—The Digital Logic Probe Kit is assembled on a printed-circuit board measuring 5-inches long and ¾-inch wide. Red-jacketed and black-jacketed alligator-clip leads are used to pirate power from the circuit-under-test. S1 is installed with its leads first placed through the circuit-board support and tack soldered to one end of the board.

GET THE LATEST ADVANCES IN ELECTRONICS

WITH A SUBSCRIPTION TO

Radio- Electronics®



ENJOY THE WORLD OF ELECTRONICS EACH MONTH!

Now you can subscribe to the best electronics magazine. The only one that brings you articles on—electronics projects, technology, circuit design, communications, new products and much more.

Radio-Electronics looks to the future and shows you what new video, audio and computer products are on the horizon. What's more you'll find helpful, monthly departments such as Video News, Equipment Reports, Hardware Hacker, Audio Update, Drawing Board, Communications Corner. All designed to give you instruction, tips, and fun.

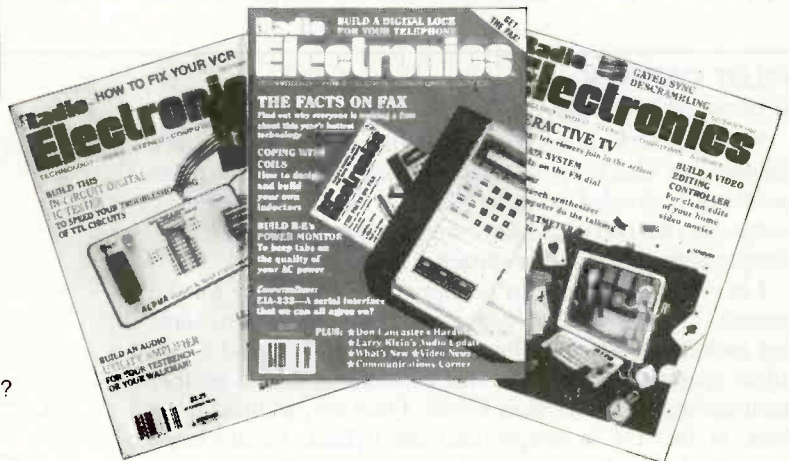

Radio-Electronics gives you exciting articles like:

- ISDN: The Telephone Network of Tomorrow
- The Facts on FAX
- A Digital Phone Lock
- How To Design Switching Circuits

PLUS: COMPUTER DIGEST! A New Kind of Magazine for Electronics Professionals.

- EIA-232 A real standard for serial interfacing?
- Build a synergy card for your PC
- '386 Power at a '286 price
- Build a biofeedback monitor
- More on Multiplexing

FOR FASTER SERVICE CALL TODAY

1-800-999-7139

DON'T DELAY SUBSCRIBE TODAY!

Just fill out the order card in this magazine and mail it in today.

BUILD THE VOX BOX

(Continued from page 81)

IC's. No provision is made to mount the override switch S1 on the circuit board. Should you decide that it is needed for your application, mount it on the box. Since the project is very light, use a toggle switch and not a slide switch—the former will be easier to operate with one finger.

The terminal pins are numbered from 1 to 10 in the schematic diagrams (Figs. 1 and 4) and the parts-placement diagram (Fig. 3). They are listed with their related circuit connections in Table 1.

Before the Test Flight

Check your work very carefully as you follow through to completion of the project. In particular, check the polarity and pin placement of the IC's, transistor, diodes, and electrolytic capacitors by comparing your work to Fig. 3.

If the VOX Box is to be controlled by signals with an amplitude of 100 millivolts or more, there is no need for the microphone preamplifier stage. Just omit all the components to the left of C4 *except* for resistors R2 and R3, and capacitor C2. Refer to the details given in Fig. 4. The impedance of the audio-signal source used as an input in Fig. 4 must be less than 5000 ohms. That output impedance is typical of many cassette and tape decks.

The threshold potentiometer, R8, may be replaced with a panel-mounting volume control of the same rating should you want to *spiff* up the VOX Box's appearance and utility.

To test VOX Box, connect the microphone and power supply, and set the R8 threshold control to maximum sensitivity. Connect an oscilloscope to the MIC OUTPUT and check the hum level in the event the preamplifier (U1) is used. Vary the setting of the GAIN control (R6) at high levels of amplification. If the hum is excessive, check the filtering capacity of the power supply. You may need 100- μ F, or more

to kill the ripple in the AC line-operated, power supply. If that doesn't work, then you must resort to a metallic enclosure. The VOX Box circuit should be grounded only at the microphone-input ground return.

Adjusting the two controls on the VOX Box is a simple procedure. The GAIN control (R6) is set to obtain the desired signal level at the MIC OUTPUT pin, while THRESHOLD control R8 is adjusted to provide reliable triggering. If you wire the circuit in Fig. 4 (not using the microphone output), set R8 to its mid-setting (50,000-ohms) and adjust R6 for reliable triggering.

Transistor battery operation is only possible for limited periods, because of the circuit's large current drain when the relay coil draws current. I used a transistor-radio battery during the test procedure and found that it provided sufficient power for about half an hour until I shut it down. How long will it operate under that type of power supply? It depends on the relay used and the total period it is on. Why not try it out and determine whether or not the VOX Box can be powered from a battery for the time intervals that you plan to use it. ■

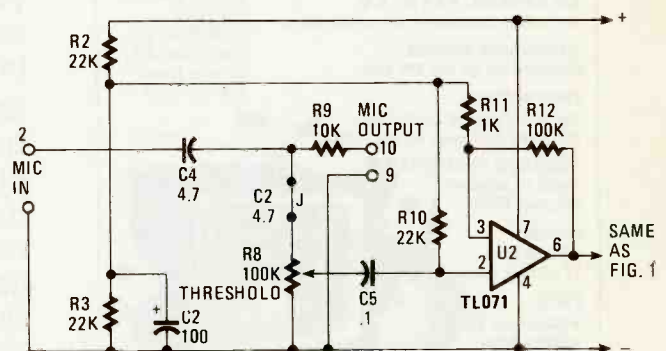

Fig. 4—Here is the revised partial schematic diagram of the unit with the preamplifier section omitted as described in text.

PILOT CARRIER

(Continued from page 40)

The project can now be used to calibrate an oscilloscope's timebase or check a counter's accuracy. If a 1 or 10 MHz oscillator is divided down to 1 kHz, it can be calibrated by comparing the two squarewave signals on a dual-trace scope. Simply adjust the trimmer capacitor for zero beat.

Let's take a moment to ponder some other uses for the project. Try replacing T1 with a magnetic telephone recording pickup and increase the values of C2, C12, and C7 to allow operation at 15 kHz. That provides access to another accurate signal source, your TV set. Place the pickup near the back of the TV to couple into the flyback transformer's magnetic field. The project will now lock onto the horizontal sync frequency broadcast by the TV station.

If the TV is tuned to a network originated program, the frequency is exactly 15734.265 Hz. All three networks use a rubidium atomic oscillator of 5 MHz from which all of the sync signals are derived. That master oscillator is compared and corrected to the National Bureau of Standards (NBS) in Boulder, Colorado.

Radio WWVB is broadcast by NBS at 60 kHz \pm 0.00001 Hz. Maybe you can use the project with a suitable antenna and preamp to decode their signal. Some experimenting and modifications of the project will be necessary to use that signal. ■

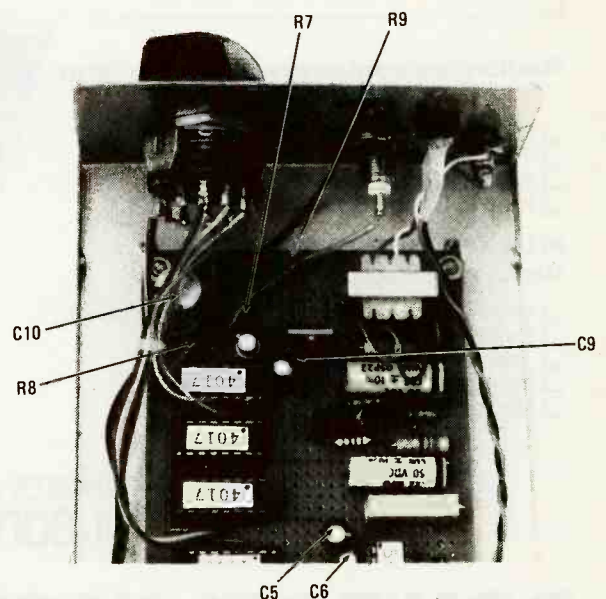

In the author's prototype, resistor R9 is not mounted to the perfboard, instead, one lead is soldered directly to J1's center (signal carrying) terminal—with its leads insulated from other components by tubing—and the other lead is connected to the junction formed by Q2 and R8.

“All I want is fair prices. Is that too much to ask?”



There is a way to get better prices on programming. The American Home Satellite Association. An organization created exclusively to protect and enhance your enjoyment of your satellite TV system.

With AHSA's group buying power you'll save on premium services, superstations and basic programming services. Enjoy savings on accessories, equipment, and programming guides, too.

A place to turn for help.

From locating satellite signals to locating a reputable dealer, the toll free AHSA "Helpline" has the answer. AHSA provides educational videotapes and informative books, too. At very special member prices.

Plus, 10 times a year, AHSA's official newsletter, *Sky Report*, will bring you the latest word on products, legislation, programming, and more. Not to mention reviews of new products and services.

You're not alone anymore.

With your voice behind us, AHSA is promoting legislation to guarantee fair access at reasonable prices. Addressing zoning and piracy issues. Even sending expert witnesses to Congressional hearings. Join other dish owners around the nation, and become a force to be reckoned with.

Rush my free information kit.

Name _____

Address _____

City _____ State _____ Zip _____

Sign me up right away and send my complete membership kit.

Check enclosed for \$36 (made out to AHSA)

Bill my VISA MasterCard

Card # _____

Exp. Date _____

Authorized Signature

X _____

30-day Money Back Guarantee



**American Home
Satellite Association**

Return completed coupon to:
American Home
Satellite Association, Inc.,
Suite 800, 500 108th Ave. NE,
Bellevue, WA 98004-5560
Or call Toll Free
1-800-321-AHSA (2472).

QRB

3-D OSCILLOSCOPE PATTERNS

(Continued from page 22)

starting with the layout of Fig. 5. It is important that the stereo viewer be properly constructed and positioned, and that you do not strain to see. Fusion occurs only when you relax your vision. Even then, psychologists tell us, perhaps 10% of the population does not normally see in stereo. However, an optometrist (after running some tests) once told me that I am *monocular*, meaning I don't see in stereo! This proved to me that the experts' tests are not always reliable.

The addition of a septum (a barrier between left and right fields of view) to the stereo viewer may be helpful in obtaining fusion. Refer to Fig. 7. The purpose of the septum is to make it physically impossible for the right eye to see the image intended for the left eye, and vice-versa, when looking through the stereo viewer. When you start seeing sinewaves in stereo, you are ready to view more-complex patterns.

Applications

To display a helix, inject a sinewave into the stereo adapter's H input and a cosinewave into the D input. A cosinewave can be obtained from the sinewave by use of an RC network as shown in Fig. 9 if you do not have a quadrature sinewave generator.

Adjust the scope's time-base controls to obtain a stationary sinewave pattern as you did in the setup procedure. Other helix displays can be produced by resetting the gain and timebase controls.

The circuit in Fig. 10 can be used to produce a bent sinewave pattern. That pattern is a plot of voltage vs. current vs. time of a sinewave of voltage across a network containing a diode.

Characteristic surfaces of other devices can be displayed, such as collector current vs. collector voltage vs. base current

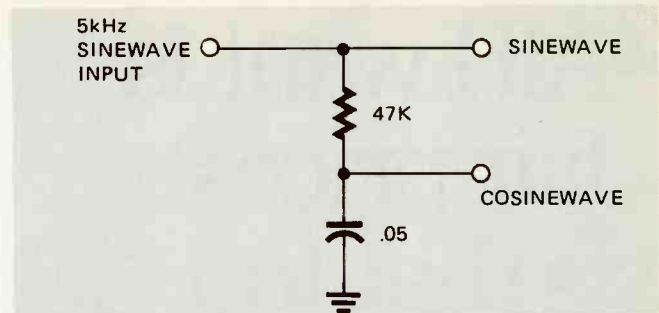

Fig. 9—This simple phase shifter will produce a cosinewave (a sinewave shifted by 90°) as long as the input sinewave is at 5 kHz. You may have to alter the value of the resistor to accommodate the components tolerances.

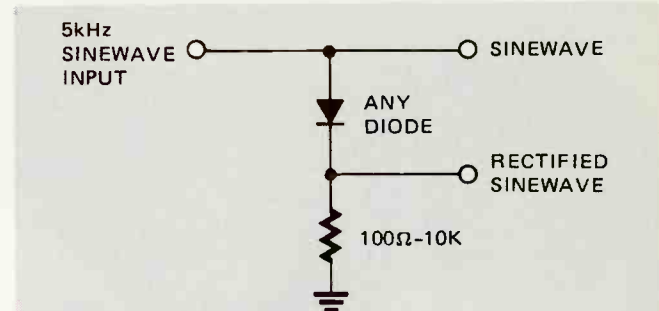

Fig. 10—Using a variable resistor in this circuit may be wise if the characteristics of the diode are unknown, or if you wish to set up a simple diode-test module.

of a transistor.

Three-dimensional Lissajous patterns and rasters can be displayed by injecting three sinewaves or sawtooth waves respectively. The variety of displays and uses for your stereo-oscilloscope is limited only by your imagination and the available instrumentation. ■

FISHING GUIDE

(Continued from page 51)

have reached the thermocline. Now make a note of the depth. (You tell the depth of the sensor by counting the number of marks on the cable that have descended into the water.)

Notice that the Hands-on Fishing Guide is not a fish finder—even lakes completely devoid of fish can have a thermocline and sometimes even ideal temperatures. The project doesn't tell you if there are fish down there, it only tells you where the fish in the lake, if any, have probably congregated.

One worthwhile tip here. Many bodies of water, (especially lakes) have what is known as a *drop-off*. That is, as its name implies, where the water becomes deeper very rapidly. Often the best place to fish is where the thermocline intersects the drop-off. It seldom is productive to fish in the middle of a lake, even in the thermocline region.

Sometimes, however, such as with salmon in the Great Lakes, the water temperature is more important than the thermocline region or drop-off. Other fish, such as lake trout and whitefish, move into the cold depths well below the thermocline. Also, some fish, like catfish, are basically bottom feeders. They pay little attention to thermoclines. Land-locked salmon, brook, brown and rainbow trout seem to prefer the bottom of the thermocline, or even just below it. Panfish, such as bluegills, seem to prefer the upper part of the thermocline. Note that Table 1 lists some popular fish, along with their preferred temperature ranges. Note that in early

TABLE 1
PLEASANT TEMPERATURES
FOR FISH

Type of Fish	Preferred Temperature Range (°F)
Largemouth Bass	67 - 77
Panfish	67 - 77
Smallmouth Bass	62 - 67
Muskellunge	62 - 72
Walleye	52 - 67
Perch	52 - 67
Northern Pike	52 - 67
Brown Trout	52 - 67
Puckerel	57 - 72
Coho Salmon	52 - 57
Brook Trout	52 - 62
Lake Trout	47 - 52

spring, many fish look for the warmest water available. Everything is relative, thus during April in the north, 50°F water temperatures might be looked upon as a semi-tropic paradise, to a sunfish.

Note that while the Hands-on Fishing Guide only measures water temperatures in a limited range, 32-77°F, at least one LED should always be on. Liquid water never gets colder than 32°F and LED10 will be lit for temperatures 77°F and above. ■

GEE WHIZ BADGE

(Continued from page 55)

not to overheat them while soldering. And they need not have to be soldered on both sides of the board. Battery connections to the Badge are made with clutch-clip pins available from any engraving shop.

The clutch pins are epoxied to the top of U2 and U3 (see Fig. 4). The positive and negative power leads are then brought up from the board and soldered to the base of the pins. The battery leads are then soldered to the clutch clasps that engage the pins. Be sure that you make your leads long enough to reach the inside pocket where you want to carry your battery. Painting around the positive pin and the mating clutch clip of the positive lead with red fingernail polish makes sure that it is polarized properly each time it is reconnected. When the pins are pushed through the shirt or coat—and the clutch clasps put on the pins from the back—power is applied through the clutch pins and hidden from view.

A 1/16-inch thick piece of badge plastic laminate (also obtained from an engraving shop) is cut to 1 1/2 by 2 1/2 inches. Using the printed-circuit board pattern, mark and drill the ten holes around the edge of the badge, through which the LED's

will project. The board can then be engraved with your favorite message and put over the circuit board with the LED's pushed through the holes. A small spot of silicon adhesive will secure the laminate to the circuit board. Be sure that you select good quality LED's to ensure that all the LED's flash with uniform brightness. The T1 size LED (available from Digi-Key Corp.) is a good choice for the LED—the color is up to you. A finishing touch is to paint the component side of the board with epoxy used for decoupage. The epoxy covers all the sharp corners of the solder connections and prevents the lead in the solder from discoloring the material of the garment on which the Badge is worn.

A kit of parts containing the printed-circuit board, two pieces of the 1 1/2-inch x 2 1/2-inch badge plastic (pre drilled for T1 LED's), and the two clutch pins and clips are available from the source shown in the Parts List. All other parts are standard and can be obtained at any electronics supply house.

You can have a lot of fun and meet a lot of different people who will just stare at the badge and say "GEE WHIZ". The best part is that you can say anything you want and you know it will be seen. The advertising space on your chest is one of the things that is truly yours alone and it's free for you and you alone to use. ■

SUPER STROBE

(Continued from page 62)

to last for any great length of time, as that will ruin the project.

In Fig. 9, we have a comparator configuration for a magnetic pickup. The pickup you should use is dependent on how much sensitivity you desire. Telephone pickup coils used to record phone conversations are fine for most applications.

As you can see in Fig. 10, even mechanical switches can be used if debounced as shown.

All of the circuits are simple and easy to apply, but they

represent just a few of the possibilities. Let your imagination be your guide!

There's nothing critical about construction of the project itself; however, be sure not to use a metal case or to allow metal hardware to come in contact with the high-voltage portions of the circuit. The circuit, if used improperly, can cause harm, for that reason it uses a common not a ground!

A perfboard can be used for the mounting of parts, or a PC board can be developed and used.

Low inductance bypass capacitors should be used between IC's along with at least one 10- to 47- μ F tantalum capacitor from +V_{dd} to the common. Wires to the LM311 comparators should be kept as short as possible to keep them from breaking in oscillation. However, LM311's are pretty stable as high-speed comparators go, and substituting other types may cause some problems.

Virtually any sensitive gate SCR that will switch the voltage will work as SCR1. The flashtube pulse transformer, plastic case, etc., can be purchased at most surplus outlets, or even Radio Shack for that matter. ■

PHONE SENTRY

(Continued from page 58)

page and used to adorn the project's enclosure, giving the Phone Sentry a professional, rather than homebrew, look. You may want to use an ordinary plastic box or aluminum chassis box for the same purpose and keep it out of sight. How you do it is your decision!

Check Out and Use

Remove the existing wire from the back of the telephone and put the short end of the cable from Phone Sentry in its place. The remaining end of the cable goes to the wall plate towards the outside line. Apply power and turn Phone Sentry on, lift the receiver and you should get a dial tone after a short delay. Call a friend and ask him or her to call you back. With D2, D3, D4, and D7 installed, the delay should be between 5-9 rings.

That's best checked by listening and counting the ringing of an extension phone. Your ring and what the caller hears as a ring are not synchronized. You may add or subtract diodes to tailor the ring delay to your specific needs. If you really want privacy, try installing D4, D7, and D6 for a delay of 9 to 13 ring cycles. Also inform the people close to you that you have the Phone Sentry in use, so they'll have to let the phone ring a little longer when calling you. After you explain to them what the Sentry does, they will probably want you to build one for them, too! ■

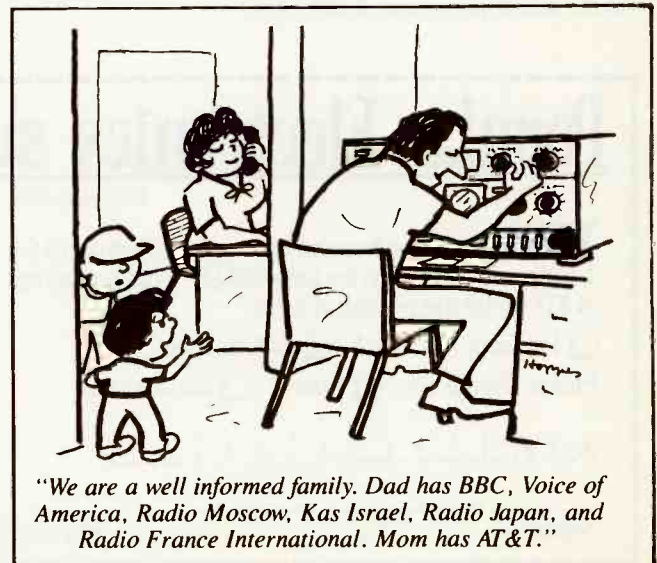

"We are a well informed family. Dad has BBC, Voice of America, Radio Moscow, Kas Israel, Radio Japan, and Radio France International. Mom has AT&T."

BINAURAL MIKESSET

(Continued from page 146)

Insert each cable into an ear hole and fish them both out the bottom. (Most wig heads have a tapering cavity inside. If yours doesn't, you'll have to provide the exit.) Make a hole at the back just above the base to feed the cables through so the set will sit nicely on a flat surface.

Press the capsules firmly into the ear holes until they are flush with the sides of the head. Strip the free ends of the wires, twist the shields together, and connect the wires to a plug that matches the jack arrangement at one end of the power supply box. That's all there is; the dummy-head mikeset is ready for use.

Headphone Mikeset

A handy way to make a headphone-type binaural mikeset is to rebuild a pair of miniature headphones. If you keep your eyes open you should be able to pick up a suitable pair for under \$5.00. All you have to do is remove the speaker elements and substitute mike capsules. Even a defective pair of phones will serve this purpose as long as the wiring harness and plug are still intact.

First, remove the foam covers from the earpieces. Gently stretch the foam and lift it away from the tiny teeth that hold it in place. Pry out the speaker elements and snip the wires attached to them.

Using a small, sharp knife, cut an opening in the plastic body of each earpiece to receive a mike capsule. The openings should be located so that the mikes will face forward when the set is placed on the head. Solder the original headphone wires to the microphone capsules, then secure the capsules in the earpiece openings with a dab of glue and replace the foam covers.

If you make a headphone mikeset, be sure to select a miniature three-conductor jack for at least one end of the power supply to match the plug supplied on the headset.

To use the mikeset, simply plug it into one end of the power

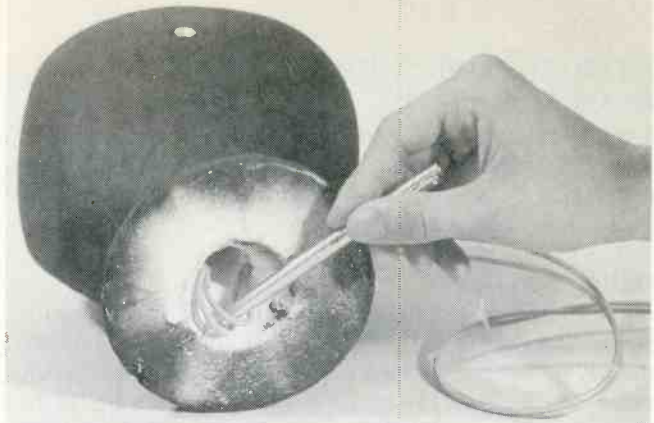

The wires from the microphone pass through the hollow center of the head. If your head doesn't have the space, you'll have to carve it out yourself with a long, thin knife.

supply box and feed the output from the other end into the mike inputs of your stereo tape recorder. For your first binaural experiment, I recommend taping household conversation and noise with the mikeset located at a usual seating location. After getting a number of minutes of sound on tape, listen to what you recorded through a pair of stereo headphones while seated right where the mike was placed.

You will also find that binaural sound is unsurpassed for making intelligible recordings of speech and conversation under difficult acoustic conditions. Try it at a conference, a lecture, or a party.

When you record live music, using a binaural mike eliminates any need for multiple mikes, mixers, and the like. Place the mikeset at a good location for live listening and tape the two channels. If you can, position the mikeset in "the best seat in the house." That would be wonderful, but you can make a realistic binaural recording even at lesser locations.

Recording music and speech is only scratching the surface. Other interesting binaural applications might be recording realistic sound effects, creating lifelike dramatic performances on tape, or (with the headphone-style mike and a battery-operated portable recorder) documenting a stroll down a city street or through the countryside. ■



\$350

■ NEW IDEAS is packed with 42 practical circuits for the Electronics Experimenter and Project Builder. In addition to the headlight alarm, the voltage freezer, and the remote telephone ringer, you get complete plans for a simple Tesla coil project that can generate 25,000-volts AC and draw one-inch sparks. Other interesting projects are: a sound-effects generator, a crystal tester, a stereo remote control, and much, much more! Each project was selected for its low cost of parts!

■ WANT TO EXPAND your knowledge of electronics? Build gadgets that only you can have on your block? Acquire a library of projects? NEW IDEAS is the gold mine of circuits you should own and read. You could start the first night building a project that will have others praising what it can do and admiring your building it.

■ THERE ARE PROJECTS for everyone—automotive, household, test equipment, audio and hi-fi, and projects just for fun.

NEW IDEAS—Circuits for Experimenters and Project Builders!

Please send one copy of NEW IDEAS at \$3.50. First Class postage and handling \$1.00 (U.S. and Canada only). All other countries: \$2.00 for sea mail, \$3.00 for air mail.

Please send _____ copies of New Ideas. Total cost is sum of copy price and First Class postage and handling cost multiplied by number of issues ordered.

Please print

Allow 6-8 weeks for the material to arrive.

Detach and mail today:

HANDS-ON ELECTRONICS
Reprint Department
500-B Bi-County Boulevard
Farmingdale, NY 11735

All Payment must be in U.S. Funds!

(Name) _____

(Street Address) _____

(City) _____

(State) _____

(Zip) _____

H187

NEW IDEAS

42 PROJECTS
COMPLETE PARTS LISTS
ONE-EVENING PROJECTS
EASY TO BUILD

SEEING THE LIGHT WITH FLASHMATE

(Continued from page 106)

meter faceplate to give you an indication of the dry cell's *health* in the future. Your calibration of Flashmate is now complete: However, you may want to repeat what you have done—practice makes perfect!

Putting It in Use

In use, Flashmate will sit where your model sits, facing the camera and lights. You set off the flash, or flashes (simultaneously or separately), then read the *f*-stop directly from the meter. You could set Flashmate in a chair or on a tripod at the location your model will occupy. Fiddle with lights and reflectors, take readings, wash away shadows with multiple bursts from your flash, use any combination of situations and lights, making notes on the Flashmate's readings. When your model arrives, you need only duplicate the setups read earlier from the meter and appear very professional without constantly taking readings. You can concentrate on creativity instead of hassling over those inscrutable little wheels on the back of your strobes. You can also throw away the old tape measure and forget guide numbers.

The chief advantage of Flashmate is that it will allow you to start making full use of your electronic flash. The computer wheels on the back of the flash unit are for full light, shot directly at your subject for the distances indicated by the settings. If you want to soften that harsh light and erase hard

shadows on your subject by bouncing the light off the ceiling or a wall (or more professionally, off an umbrella reflector). The light must travel farther and be scattered, so that at the model it appears that many small spots were shot off at the same time, rather than just one large one. Therefore, less of that light reaches the model (because some is misdirected away from the model and some is absorbed by the walls, floor, and ceiling) and the direct-flash setting is no longer valid.

Except in rare instances for special effect, more than one light is used in studio photography. At least two, usually three or four, lights are used whether the subject is a gorgeous model or a bowl of bananas. To use more than one flash unit or strobelight, you can use a multiple-flash adaptor which is a small p.c. (nothing to do with computers) connector with more than one synch cord socket on it. That adaptor can connect your camera to as many as four flash-unit synch cords.

More often in studios, the pro will use one main flash unit connected to the camera and several other flash units fitted with slave units. A slave unit is provided with an optical switch (some kind of solar cell) which sees the main flash go off and triggers the slave unit(s) to fire at the same time. In all those multiple flash situations, you need to measure the combined result at the point of focus: your model. Just the first few applications of Flashmate will save you enough cash (by not wasting film) to repay you for your Flashmate's parts. Good shooting, and may the Flashmate be with you! ■

BUILD A NIGHT OWL

(Continued from page 92)

you can substitute any 117-VAC to 9 (or 12)-VDC plug-in adapter.

Instead of using plug PL1 and socket SO1, you could substitute a 6-foot electrical extension cord. Just cut it into halves and use one end for plug PL1 and the other end for socket SO1. (If you look at the schematic shown in Fig. 2, you'll see that PL1 is for the electrical wall outlet, while SO1 is for the lamp fixture.

It's important to use an appropriate plastic enclosure (do

not use a metal box) and make certain that all the powerline connections to K1 are properly connected and terminated.

Lost and Found

Some people might find it difficult to locate a remote switch in the dark. For them, the optional *Illuminated Remote Switch* shown in Fig. 7 was designed. (The illuminated remote switch is shown within the dashed outline.)

As shown, a 3-terminal DIN connector is substituted for J1, while a matching DIN plug substitutes for PL2. V_{CC} is applied through pin-1 of the DIN connectors; pin-2 is used for the LED's ground return; pin-3 is used to apply the clock input for the toggle flip-flop. ■

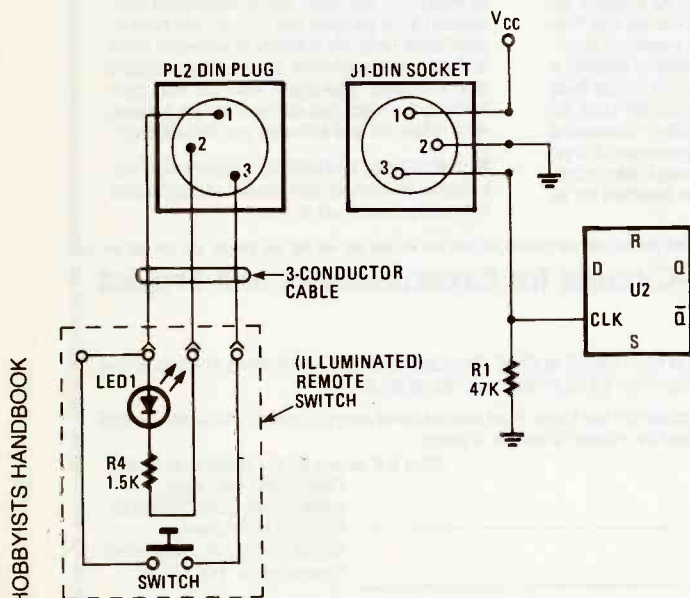
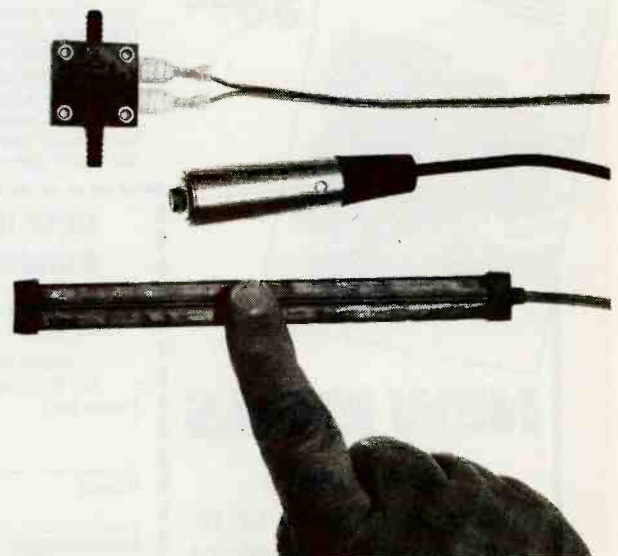

Fig. 7—If you want a remote control to be illuminated, assemble the switch as shown within the dotted box and substitute the 3-pin DIN connectors for PL2 and J1.



Some of the unusual switches that can be used with the *Night Owl* are the puff switch (top), cord switch (center), and the ribbon (or touch) switch (center).

SUMMERTIME, AND THE LIVIN' AIN'T EASY.



Especially for one person like yourself who's trying to do the work of three. So you not hire one or two of the thousands of young disadvantaged people looking for work this summer. Hiring them can also help you get as much as an 85% tax credit on the first \$3,000 in wages you pay to one of these summer employees. For further information, write the National Alliance of Business at P.O. Box 7207, Washington, D.C. 20044. And support your local summer-jobs-for-youth programs. Make living in the summertime easy.

LET'S GET ALL OF AMERICA WORKING AGAIN.

A PUBLIC SERVICE
OF THIS PUBLICATION & Ad
THE ADVERTISING COUNCIL COUNCIL

DM-3650-B LARGE LCD 3½
DIGIT MULTIMETER WITH CARRYING
CASE AND BAR GRAPH
THE BEST AT THE LOWEST
PRICE UNDER **\$110.00**
0.3% READING HAS A.C & D.C CURRENT
AND VOLTAGE HAS RESISTANCE,
CAPACITANCE AND FREQUENCY MAX
DISPLAY 3999 COUNTS W/AUTO POL IND
20 AMP CURRENT RANGE

DM-80 LARGE LCD 3¾ AUTO
RANGE DIGITAL MULTIMETER
TOP QUALITY AT THE LOWEST PRICE
A.C & D.C. CURRENT AND VOLTAGE 0.5%
ACCURACY RESISTANCE AND
FREQUENCY MAX DISPLAY 3999 COUNTS
WITH AUTO POL. IND. OVERRANGE
INDICATOR W/CASE AND LEADS AND
BATTERY 20 AMP CURRENT SCALE
PRICE UNDER **\$93.00**

DMR-2012 3½ DIGIT 28 RANGE
W/CASE & CAPACIT. UNDER **\$65.00**

DMR-2208 3½ DIGIT 38 RANGE
W/CASE .3% UNDER **\$63.00**

ALL UNITS EQUIPPED WITH HIGH IMPACT
CABINET AND WARRANTED FOR ONE YEAR.

AVAILABLE AT YOUR LOCAL
ELECTRONIC DISTRIBUTOR
OR NATIONWIDE CATALOG HOUSE.
516/845-7081. WRITE FOR FREE 10-PG.
COLOR CATALOG

EMCO ELECTRONICS
P.O. BOX 327 PLAINVIEW, N.Y. 11803
WE HAVE 37 UNITS IN OUR LINE
INCLUDING SCOPES. POWER SUPPLIES ETC

CIRCLE 23 ON FREE INFORMATION CARD

ELECTRONICS MARKET PLACE

FOR SALE

MONSTER bi-color LED, 12 flashing elements in 3" dome, \$12. Touch switch, stays on so long as in skin contact, 200ma, \$4.90. Sound activated switch, 10ua standby current, panel mountable, \$6.90. Mini DC converters: input 3v(DD3510) or 9v(DD9510), output 5.5v, 100ma, @\$5.90. 10% off 3 devices up, instructions included, postpaid, guaranteed. **PARAWING**, PO Box 65, Menlo Park, CA 94026.

WE buy and sell receiving, transmitting, and industrial tubes. Thousands in stock. **DH DISTRIBUTORS**, PO Box 48623, Wichita KS, 67201.

ENGINEERING software, PC/MSDOS. Hobbyists - students - engineers. FFT analysis, circuit design, mathematics, logic simulation, circuit analysis. Free catalog, (614) 491-0832, **BSOFT SOFTWARE**, 444 Colton Rd., Columbus, OH 43207.

LOW prices capacitors, IC's, transistors, switches. Special 27128A-25 \$3.25. 7805s or 7812s 20/\$5.00. Flyer SASE. **SANTECH ELECTRONICS**, 11 Revere Place, Tappan, NY 10983. (914) 359-1130.

DESCRAMBLERS. All brands. Special: Jerrold combo 400 and SB3 \$165. Complete cable descrambler kit \$39. Complete satellite descrambler kit \$45.00. Free catalog. **MJK INDUSTRY**, Box 531, Bronx, NY 10461-0531.

PLANS AND KITS

CIRCUIT boards for projects in this magazine about half price. **KLAY-CORP**, 106 Mark Drive, Syracuse, NY 13209-1808.

FM stereo transmitter. Transmit your VCR/CD/WALKMAN to any FM stereo radio. One chip does it all! Free schematic and info. Send a self addressed/stamped envelope to: **DJ INC.**, 847A Second Ave., Suite 113, New York, NY 10017.

SATELLITE TV

FREE catalog. Systems, upgrades, Houston, Uniden, Chaparral, etc. Save \$\$\$\$\$. **SKYVISION**, 2040 Collegeway, Fergus Falls, MN 56537. 1(800) 334-6455.



TUBES - 2000 TYPES DISCOUNT PRICES!

Early, hard-to-find, and modern tubes. Also transformers, capacitors and parts for tube equipment. Send \$2.00 for 24 page wholesale catalog.

ANTIQUE ELECTRONIC SUPPLY
688 W. First St. • Tempe, AZ 85281 • 602/894-9503



NEW HE NE LASER TUBES \$35

Dealer Inquiries Invited.
Free Catalog!

MEREDITH INSTRUMENTS: 6403 N. 59th Ave.
Glendale, AZ 85301 • (602) 934-9387
"The Source for Laser Surplus"

DIGITAL CAR DASHBOARDS

BUILD yourself complete electronic dashboards. Send \$1 (refundable) for details. **MODERN LABS**, 2900N Ruisseau, Saint-Elizabeth, QC, J0K 2J0, Canada.

CABLE-TV BOXES

Descramblers • Converters

FREE CATALOG

TRANS-WORLD CABLE CO.
12062 Southwest 117th Ct., Suite 126
Miami, Florida 33186
800-442-9333

MODERN ELECTRONICS Kits by Electronic Design Specialists: the Semi-analyzer, the Bus Line Tracer, the Teletester, the Programmable Light Controller, the A/C Sentry, more. Write for catalog.

EDS, Inc.
951 SW 82 Ave., N. Lauderdale, FL 33068.

BUY BONDS

DIGI LYZER IC TESTER

(Continued from page 45)

check out the more complex chips such as counters, registers, one shots, and flip-flops. The parts count for the unit is

minimal, and the cost is modest compared to its usefulness on your test bench. After you are thoroughly familiar with its operation, you can tackle that ash tray full of questionable chips that we all know you have hidden somewhere around your workbench. ■

PARTS LIST FOR THE DIGI-LYZER IC TESTER

RESISTORS

(All resistors 1/4-watt, 5% fixed units)

R1-R16—150-ohm
R17-R32—470-ohm
R33-R50—220-ohm

SEMICONDUCTORS

LED1, LED3, LED5, LED7, LED9, LED11, LED13, LED15, LED17, LED19, LED21, LED23, LED25, LED27, LED29, LED31—Light-emitting diode, red
LED2, LED4, LED6, LED8, LED10, LED12, LED14, LED16, LED18, LED20, LED22, LED24, LED26, LED28, LED30, LED32—Light-emitting diode, green
LED33, LED34, LED35, LED36, LED37, LED38, LED39, LED40, LED41, LED42, LED43—Light-emitting diode, yellow
U1-U6—4049 CMOS hex inverting buffer, integrated circuit

SWITCHES

PB1-PB16—Normally-open pushbutton switch, Digi-Key part No. P9951 (Digi-Key Corp., PO Box 677, Thief River Falls, MN 56701; 1-800/344-4539)

S1 to S11—Two-position slide switch, CK Part No. 1201
M2 CQE (C and K Components, 15 Riverdale Ave., Newton, MA 02158-1082; for nearest stocking distributor call: 1-800/243-8160)

S12—Single-pole, double-throw (SPDT) center-off switch

ADDITIONAL PARTS AND MATERIALS

B1-B6—Battery, "C" or "D" cell
SO1—Zero-Insertion Force (ZIF) socket, 14 pin, Part No. 214-3339 (Jameco Electronics, 1355 Shoreway Road, Belmont, CA 94002; Tel. 415/592-2503)
SO2—Zero-Insertion Force (ZIF) socket, 16 pin, Part No. 216-3340 (Jameco Electronics, 1355 Shoreway Road, Belmont, CA 94002; Tel. 415/592-2503)
Printed-circuit board (see below for supplier), enclosure, batteries, battery holders, hardware, wire, solder, etc.

Note: An etched and pre-drilled printed-circuit board is available priced at \$18.50 (including shipping and handling) from Electronic Enterprises, 3305 Pestana Way, Livermore, CA 94550.

ELECTRONICS LIBRARY

(Continued from page 10)

applications for students, hobbyists, or anyone with an interest in lasers. Arranged similarly to a textbook, the concise text

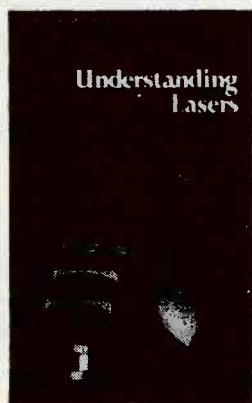

is accompanied by illustrations, and each chapter concludes with a summary and a self-quiz. A broad overview of lasers is followed by a review of the fundamental concepts of physics, quantum mechanics, and optics needed to understand laser technology. The book explains how lasers work, and describes the accessories—including lenses, prisms, and "active" optics that bend laser light—that help them work more effectively.

Subsequent chapters provide detailed coverage of the three laser families: gas, solid-

state, and semiconductor. Free-electron and X-ray lasers are discussed, and applications of lasers in medicine, industry, and communications are presented.

Understanding Lasers is available for \$17.95 from Howard W. Sams & Company, 4300 West 62nd St., Indianapolis, IN 46268; Tel. 800-428-SAMS.

CIRCLE 95 ON FREE INFORMATION CARD



"Let me get this straight, Byron, you invented a solar-powered umbrella?"

ADVERTISING INDEX

P-E HOBBYIST HANDBOOK magazine does not assume any responsibility for errors that may appear in the index below.

Free Information No.	Page
14	All Electronics6
18	Amazing Devices 151
—	American Home SAT Assoc. ... 157
10	CIE 17
11	C & S Sales 9
—	Command Productions 8
20	Cook's Institute 10
15, 16	Datak 5
19	Dick Smith 151
12	Digi Key C2
—	Electronic Book Club 3, C3
—	Electronic Tech. Today 53, C4
—	EIA 54
23	Emco 163
21	Jensen Tools 10
22	Mouser 8
—	NRI 35, 133
—	Panavise 7

SELECT 5 BOOKS for only \$395

(values to \$211.80)

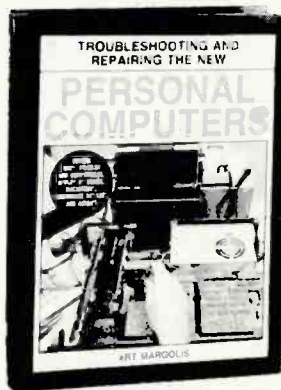
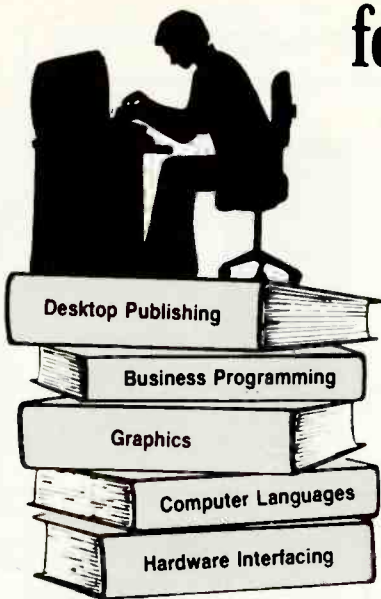

2809 \$26.95
Counts as 2

When it's new and important in business or personal computing, The Computer Book Club® has the information you need . . . at savings of up to 50% off publishers' prices!

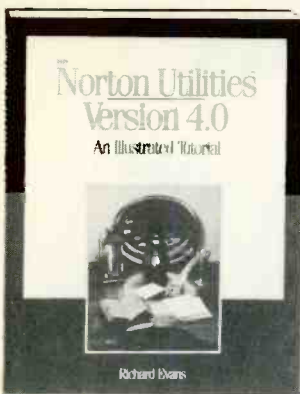

2929P \$15.95



1848P \$16.95



2870 \$24.95



2852P \$17.95



2807P \$14.95



2913P \$14.95



3032P \$12.95



2838 \$19.95



3119P \$21.95

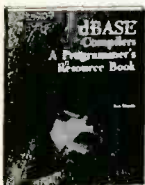

2943P \$18.95

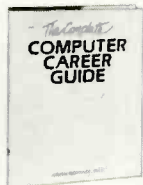

265 \$19.95



3030P \$17.95



9200P \$24.95



9829 \$45.00



3146P \$17.95

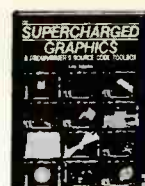

2959 \$29.95
Counts as 2



3031 \$24.95



2855P \$16.95



2856P \$18.95



3127P \$16.95



3116 \$27.95
Counts as 2



2841P \$15.95

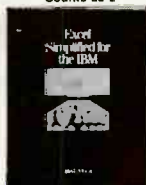

2968P \$19.95



9083 \$29.95
Counts as 2



9785 \$86.95



3109 \$28.95



3026 \$22.95

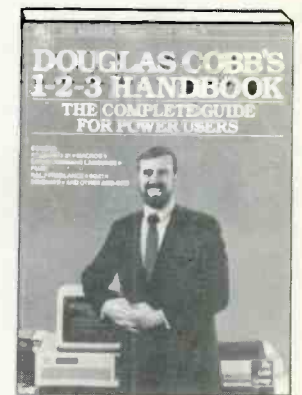

9779P \$22.95

Membership Benefits • Big Savings. In addition to this introductory offer, you keep saving substantially with members' prices of up to 50% off the publishers' prices. • **Bonus Books.** Starting immediately, you will be eligible for our Bonus Book Plan, with savings of up to 80% off publishers' prices. • **Club News Bulletins.** 14 times per year you will receive the Book Club News, describing all the current selections—mains, alternates, extras—plus bonus offers and special sales, with scores of titles to choose from. • **Automatic Order.** If you want the Main Selection, do nothing and it will be sent to you automatically. If you prefer another selection, or no book at all, simply indicate your choice on the reply form provided. As a member, you agree to purchase at least 3 books within the next 12 months and may resign at any time thereafter. • **Ironclad No-Risk Guarantee!** If not satisfied with your books, return them within 10 days without obligation. • **Exceptional Quality.** All books are quality publishers' editions especially selected by our Editorial Board.

All books are hardcover unless numbers are followed by a "P" for paperback. (Publishers' Prices Shown)
©1989 THE COMPUTER BOOK CLUB® Blue Ridge Summit, PA 17294-0820



The Computer Book Club®

Blue Ridge Summit, PA 17294-0820

Please accept my membership in The Computer Book Club® and send the 5 volumes listed below, billing me \$395 plus shipping and handling charges. If not satisfied, I may return the books within ten days without obligation and have my membership canceled. I agree to purchase at least 3 books at regular Club prices (plus shipping/handling) during the next 12 months and may resign any time thereafter.

Name _____
Address _____
City _____
State _____ Zip _____ Phone _____

Signature _____
Valid for new members only. Foreign applicants will receive special ordering instructions. Canada must remit in U.S. currency. This order subject to acceptance by The Computer Book Club®. PEHC489



2793P \$16.95



3c49 \$36.95
Counts as 2



2812 \$24.95



2997 \$25.95



9762P \$21.95



9810 \$24.95

Electronics Paperback Books

GREAT PAPERBACKS AT SPECIAL PRICES



BP238—GETTING THE MOST FROM YOUR MULTIMETER..... \$5.95. Covers basics of analog and digital meters. Methods of component testing (includes transistors, thyristors, resistors, capacitors and other active and passive devices)



BP146—THE PRE-BASIC BOOK..... \$5.95. A book on the BASIC programming for those who have not yet bought a computer as well as those who have trouble learning how to program.

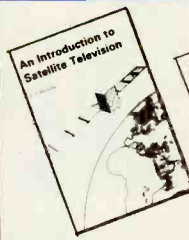

BP195—INTRODUCTION TO SATELLITE TV..... \$9.95. A definitive introduction to the subject written for the professional engineer, electronics enthusiast, or others who want to know more before they buy. 8 x 10 in.



PCP102—INTRODUCING DIGITAL AUDIO..... \$9.95. CD, DAT, and sampling. What is involved in the digital part of audio signals. Principles and practices of digital audio techniques



RFTD—RADIO'S FIRST TWO DECADES..... \$3.50. The story of radio's early days makes for fascinating reading. Spark-gap transmitters, KDKA's beginnings, and much more.



PCP103—PRACTICAL MIDI HANDBOOK..... \$9.95. Explains what MIDI (the Musical Digital Interface) can do and how you can put it to work. Covers Keyboards, drum machines, sequencers, mixers, guitars, and computer music.



BP178—TV DINKING FOR THE ENTHUSIAST..... \$7.95. Practical, authoritative intro to this unusual aspect of electronics. 8 1/2 x 11 in. 144 pp.



BP173—COMPUTER MUSIC PROJECTS..... \$6.95. Shows how to use your home computer to produce electronic music. Many circuits. Mostly jargon free.



BP136—SECRETS OF THE COMMODORE 64..... \$5.75. Masses of useful info and programming tips not found in any user's manual.



BP143—INTRO TO PROGRAMMING THE ATARI 800/800 XL..... \$5.95. Perfect complement to the Atari user's manual. Even shows how to use animated graphics.



BP131—MICRO INTERFACING CIRCUITS—BOOK 1..... \$5.75. Practical add-ons transform your computer into control or measurement equipment.



BP148—COMPUTER TECHNOLOGY EXPLAINED..... \$5.50. Explanations for computer terms often encountered. A dictionary for computer lingo.



BP152—INTRO TO Z-80 MACHINE CODE..... \$5.95. Speed up your programs. They may be harder to write, but fit worth learning how. Some demo programs are included.



BP108—ANTENNA PROJECTS..... \$5.50. Practical radio antenna designs that deliver good performance and are relatively simple and inexpensive to build.



BP144—FURTHER PRACTICAL ELECTRONICS CALCULATIONS AND FORMULAE..... \$9.00. Companion volume to the book's computer to the robot's motors and sensors.



BP125—25 SIMPLE AMATEUR BAND ANTENNAS..... \$5.50. All kinds of antennas for all kinds of amateur radio reception.



BP134—EASY ADD-ON PROJECTS FOR COMMODORE 64, VIC-20, BBC MICRO & ACORN ELECTRON..... \$6.95. Picture digitizer, light pen, model controller and more.



BP179—ELECTRONIC CIRCUITS FOR THE COMPUTER CONTROL OF ROBOTS..... \$7.50. Data and circuits for interfacing the computer to the robot's motors and sensors.

Quality Paperbacks



BP183—AN INTRODUCTION TO CP/M..... \$6.95. To run and use programs operations under CP/M you need this book.



BP127—HOW TO DESIGN ELECTRONIC PROJECTS..... \$5.75. How to use standard circuit elements to make custom electronic projects.



BP110—HOW TO GET YOUR ELECTRONIC PROJECTS WORKING..... \$5.75. How to find the faults in your projects, repair them and get them working.



BP121—DESIGN & MAKE YOUR OWN PC BOARDS..... \$5.75. Everything you need to know before you make printed-circuit boards for your projects.



BP85—ELECTRONIC SECURITY DEVICES..... \$5.50. Three basic sections. Switch activated alarms, infrared & ultrasonic systems, smoke, gas, water detection.



BP85—INTERNATIONAL TRANSISTOR EQUIVALENTS..... \$7.50. Locates possible substitutes for a popular user-oriented selection of modern transistors. Japanese, European and American types.



BP117—PRACTICAL ELECTRONIC BUILDING BLOCKS. Book 1..... \$5.75. Build the blocks and then combine them to form almost any custom project of your choice.

BP177—MICRO-PROCESSING SYSTEMS AND CIRCUITS..... \$5.95. Guide to the elements of micro-processing systems. Teaches all the fundamentals.



BP118—PRACTICAL ELECTRONIC BUILDING BLOCKS. Book 2..... \$5.75. Amplifiers for all kinds to add to the circuits from Book 1 of this series.

BP169—HOW TO GET YOUR COMPUTER PROGRAMS RUNNING..... \$5.95. Have you ever written your own programs only to find that they do not work? This book shows you how to find errors.



BP108—MODERN OP-AMP PROJECTS..... \$5.00. Includes a Slide Timer, AF Signal Gen, Mixer, Pre-amp, Scratch Filter, and much more.



BP59—SECOND BOOK FOR CMOS IC PROJECTS..... \$5.50. Multivibrators, amplifiers, triggers & gates, special devices including reaction timer, simple electronic organ, and more.



BP182—MIDI PROJECTS..... \$6.95. Details of how to interface many popular home computers with MIDI music systems.



Affordable Prices



BP128—20 PROGRAMS FOR THE ZX SPECTRUM & ZX81..... \$5.75. All programs run on both machines. Include flow charts and info on how to modify to run on other computers.



BP108—MODERN OP-AMP PROJECTS..... \$5.00. Includes a Slide Timer, AF Signal Gen, Mixer, Pre-amp, Scratch Filter, and much more.



BP165—ELECTRONIC SYNTHESIZER CONSTRUCTION..... \$6.95. Shows how to build a monophonic synthesizer. Section by section. Replaces BP81.



BP182—MIDI PROJECTS..... \$6.95. Details of how to interface many popular home computers with MIDI music systems.



BP85—SINGLE IC PROJECTS..... \$5.75. All projects in the book are based on one IC and are simple to construct. Great way to get started with IC's.



BP49—POPULAR ELECTRONIC PROJECTS..... \$5.95. A collection of a wide range of electronic projects and circuits for the experimenter.

BP97—IC PROJECTS FOR BEGINNERS..... \$5.50. Written especially for the less experienced experimenter. Complete parts layouts and wiring diagrams.



BP181—INTO THE QL ARCHIVE..... \$4.95. Presents the powerful database for the Sinclair QL. Step-by-step approach includes practical examples.



BP90—POPULAR ELECTRONIC CIRCUITS. Book 1..... \$5.95. More circuits for hobbyists. Audio, radio, test, music, household and more.



BP98—POPULAR ELECTRONIC CIRCUITS. Book 2..... \$5.95. More useful circuits. None of these projects duplicate those in Book 1 of this series.

CHECK OFF THE BOOKS YOU WANT

ELECTRONIC TECHNOLOGY TODAY INC.
P.O. Box 240, Massapequa Park, NY 11762-0240

Name _____
Address _____
City _____ State _____ Zip _____

PEH89

SHIPPING CHARGES IN USA AND CANADA

\$0.01 to \$5.00 \$1.25
\$5.01 to 10.00 \$2.00
\$10.01 to \$20.00 \$3.00
\$20.01 to \$30.00 \$4.00
\$30.01 to \$40.00 \$5.00
\$40.01 to \$50.00 \$6.00
\$50.01 and above \$7.50

SORRY, No orders accepted outside of USA and Canada

Total price of merchandise \$ _____
Sales Tax (New York State Residents only) \$ _____
Shipping (see chart) \$ _____

All payments must be in U.S. funds

Total Enclosed . . . \$ _____

Number of books ordered