

# EVERYDAY **ELECTRONICS** and computer **PROJECTS**

SEPTEMBER 1983

85p

## **STYLUS ORGAN** WITH VIBRATO AND DECAY

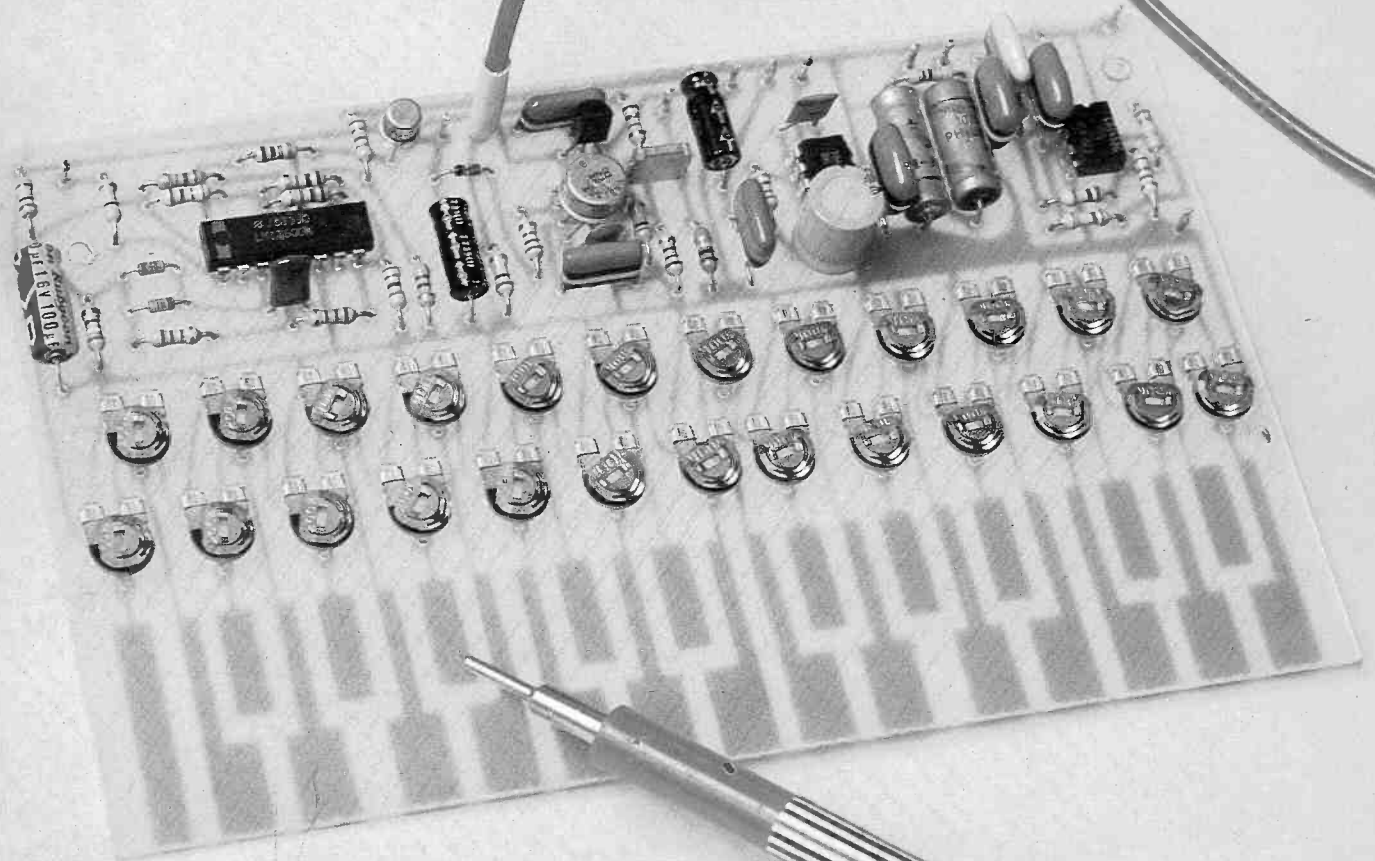
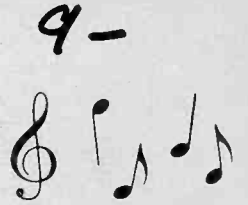

**A TO D CONVERTER FOR  
RM380Z COMPUTER**

**VOLTAGE DUALISER**

**DISTRESS BEACON FOR YACHTSMEN,  
FELL WALKERS AND MOUNTAINEERS**

electronize

# AUTO-ELECTRONIC PRODUCTS

## KITS OR READY BUILT

### TOTAL ENERGY DISCHARGE ELECTRONIC IGNITION

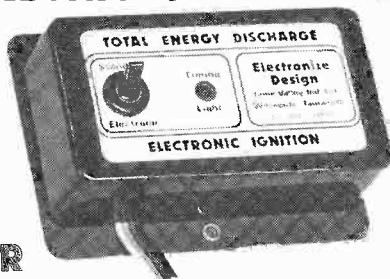

### IS YOUR CAR AS GOOD AS IT COULD BE ?

- ★ Is it **EASY TO START** in the cold and the damp? Total Energy Discharge will give the most powerful spark and maintain full output even with a near flat battery.
  - ★ Is it **ECONOMICAL** or does it "go off" between services as the ignition performance deteriorates? Total Energy Discharge gives much more output and maintains it from service to service.
  - ★ Has it **PEAK PERFORMANCE** or is it flat at high and low revs where the ignition output is marginal? Total Energy Discharge gives a most powerful spark from idle to the engines maximum (even with 8 cylinders).
  - ★ Is its **PERFORMANCE SMOOTH**, the more powerful spark of Total Energy Discharge eliminates the "near misses" whilst an electronic filter smoothed out the effects of contact bounce etc.
  - ★ Do the **PLUGS and POINTS** always need changing to bring the engine back to its best? Total Energy Discharge eliminates contact arcing and erosion by removing the heavy electrical load. The timing stays "spot on" and the contact condition doesn't affect the performance either. Larger plug gaps can be used, even wet or badly fouled plugs can be fired with this system.
  - ★ **TOTAL ENERGY DISCHARGE** is a unique system and the most powerful on the market - 3 1/2 times the power of inductive systems - 3 1/2 times the energy and 3 times the duration of ordinary capacitive systems. These are the facts:  
**Performance at only 6 volts (max. supply 16 volts)**  
 SPARK POWER — 140W, SPARK ENERGY — 36mJ  
 SPARK DURATION — 500µS, STORED ENERGY — 135mJ  
 LOADED OUTPUT VOLTAGE  
 50pF load — 38kV, 50pF + 500k — 26kV
- We challenge any manufacturer to publish better performance figures. Before you buy any other make, ask for the facts, its probably only an inductive system. But if an inductive system is what you really want, we'll still give you a good deal.
- ★ **ALL ELECTRONIZE** electronic ignitions feature:  
**EASY FITTING, STANDARD/ELECTRONIC CHANGEOVER SWITCH, STATIC TIMING LIGHT and DESIGNED IN RELIABILITY (14 years experience and a 3 year guarantee).**
  - ★ **IN KIT FORM** it provides a top performance system at less than half the price of comparable ready built units. The kit includes: pre-drilled fibreglass PCB, pre-wound and varnished ferrite transformer, high quality 2µF discharge capacitor, case, easy to follow instructions, solder and everything needed to build and fit to your car. All you need is a soldering iron and a few basic tools.

Most **NEW CARS** already have electronic ignition. Update **YOUR CAR**

### PROTECT YOUR CAR WITH AN ELECTRONIZE ELECTRONIC ALARM

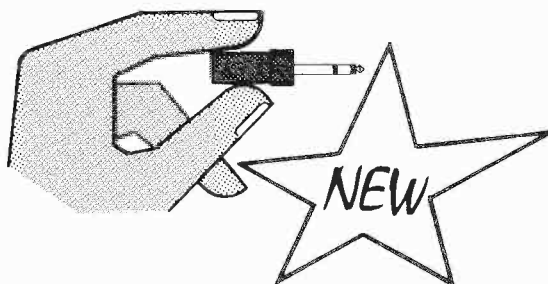

- ★ **2000 COMBINATIONS** provided by an electronic key - a miniature jack plug containing components which must match each individual alarm system. (Not limited to a few hundred keys or a four bit code).
  - ★ **60 SECOND ALARM PERIOD** flashes headlights and sounds horn, then resets ready to operate again if needed.
  - ★ **10 SECOND ENTRY DELAY** allows owner to dis-arm the system, by inserting the key plug into a dashboard mounted socket, before the alarm sounds. (No holes in external bodywork, fiddly code systems or hidden switches). Re-closing the door will not cancel the alarm, before or after it sounds, the key plug must be used.
  - ★ **INSTANT ALARM OPERATION** triggered by accessories or bonnet/boot opening.
  - ★ **30 SECOND DELAY** when system is armed allows owner to lock doors etc.
  - ★ **DISABLES IGNITION SYSTEM** when alarm is armed.
  - ★ **IN KIT FORM** it provides a high level of protection at a really low cost. The kit includes everything needed, the case, fibreglass PCB, CMOS IC's, random selection resistors to set the combination, in fact everything down to the last nut and washer plus easy to follow instructions.
- FITS ALL 12 VOLT NEGATIVE EARTH VEHICLES.  
 SUPPLIED COMPLETE WITH ALL NECESSARY LEADS  
 AND CONNECTORS PLUS TWO KEY PLUGS**

Don't Wait Until Its too Late ~  
Fit one **NOW!**

fill in the coupon and send to:

**ELECTRONIZE DESIGN** Dept C · Magnus Rd · Wilnecote · Tamworth · B77 5BY · tel 0827 281000

#### TOTAL ENERGY DISCHARGE (6 or 12 volt negative earth)

- Assembled ready to fit **£26.70** £19.95
- D.I.Y. parts kit **£15.90** £14.95

#### TWIN OUTPUT for cars and motor cycles with dual ignition

- Twin, Assembled ready to fit **£36.45** £29.95
- Twin, D.I.Y. parts kit **£24.55** £22.95

PLEASE SEND MORE INFORMATION

Goods normally despatched within 7 days.

Prices Include VAT.

P+P £1-00 (UK)

#### CAR ALARM

- Assembled ready to fit **£37.95**
- D.I.Y. parts kit **£24.95**

I enclose cheque/postal order OR debit my Access/Visa card

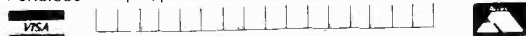

Name \_\_\_\_\_

Address \_\_\_\_\_

\_\_\_\_\_

\_\_\_\_\_ Code \_\_\_\_\_

C

# EVERYDAY ELECTRONICS and computer PROJECTS

VOL. 12 NO. 9 SEPTEMBER 1983

PROJECTS . . . THEORY . . . NEWS . . .  
COMMENT . . . POPULAR FEATURES . . .

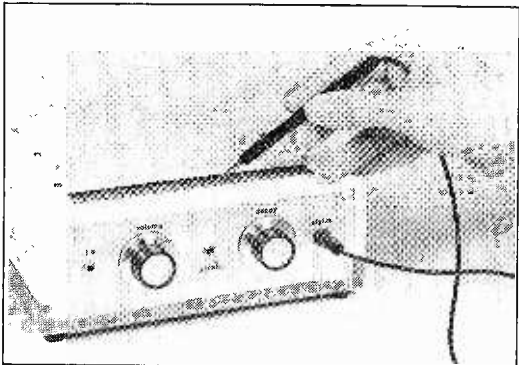
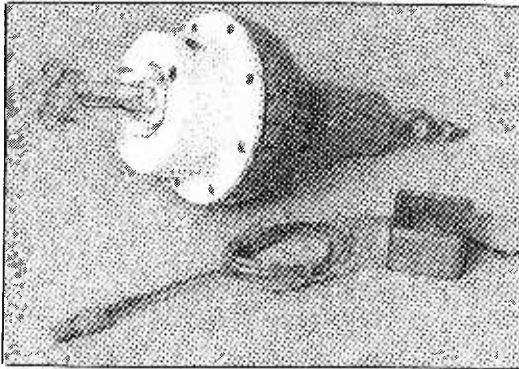

## PRICE INCREASE

As from next month the cover price of Everyday Electronics will be 90p. This increase of 5p is regretted but unavoidable if we are to maintain present standards and to offer a wide range of projects each month. We are sure readers will agree that considering the wealth of detailed information for the constructor contained within EE every month, the new price of 90p represents good value.

© IPC Magazines Limited 1983. Copyright in all drawings, photographs and articles published in EVERYDAY ELECTRONICS is fully protected, and reproduction or imitations in whole or in part are expressly forbidden.

## PROJECTS

- STYLUS ORGAN** by R. A. Penfold 554  
Two-octave instrument with vibrato and decay
- A-to-D CONVERTER FOR RM380Z COMPUTER**  
by A. A. Chanerley 559  
8-channel 8-bit wide Analogue-to-Digital Converter
- DISTRESS BEACON** by P. E. Hopkins 566  
Rescue aid for mariner or mountaineer
- HIGH SPEED ANALOGUE-TO-DIGITAL CONVERTER** by J. Adams & G. M. Feather 582
- SIGNAL CONDITIONING AMPLIFIER**  
by J. Adams & G. M. Feather 586
- TRAFFIC LIGHT SIMULATOR** by N. P. Naughton 602  
Teach your children road safety
- VOLTAGE DUALISER** by L. S. Cook 606  
8 + 8V power supply with overload protection

## SERIES

- ELECTRONICS AND THE ELECTRON** by J. B. Dance 576  
Part 5: Doped semiconductor materials
- MICROCOMPUTER INTERFACING TECHNIQUES**  
by J. Adams & G. M. Feather 580  
Part 3: Analogue-to-Digital Conversion
- COMPUTER AIDED EXPERIMENTS**  
by A. A. Chanerley 600  
Part 1: Investigation of diffraction patterns

## FEATURES

- EDITORIAL** 553  
Building For The Future
- COUNTER INTELLIGENCE** by Paul Young 564  
A retailer comments
- SHOPTALK** by Dave Barrington 565  
Product news and component buying
- CIRCUIT EXCHANGE** 578, 611  
A forum for readers' ideas
- FOR YOUR ENTERTAINMENT** by Barry Fox 579  
Video Facts; Teleprompting
- EVERYDAY NEWS** 590  
Special Schools Electronic Design Awards Report
- SEDAC 1983** 592  
The twelve winning designs
- SPECIAL REPORT** by G. P. Hodgson 598  
ZX81 Personal Computer
- BOOK REVIEWS** 604, 608  
A selection of recent releases
- RADIO WORLD** by Pat Hawker G3VA 605  
Political No-speak; Museum of Television; Japanese No-code
- READER'S LETTERS** 608  
Your news and views
- NEW PRODUCTS** 609  
Facts and photos of instruments, equipments and tools
- SQUARE ONE** 610  
Beginners' Page: Circuit Symbols

Our October 1983 issue will be published on Friday, September 16. See page 589 for details.

Readers' Services • Editorial and Advertisement Departments 553

Where on Earth can I obtain top quality Transistors, Ic's, Capacitors, Resistors, Cases, Cable, Fuses, Bulbs, Plugs, Sockets, Nuts, Bolts, Coils, Chokes, Test Instruments & Books, all at a price I can afford ?



But of Course !!!

Express Mail Order Service

Callers Most Welcome

# Twyford

ELECTRONICS LIMITED

22 STATION ROAD, TWYFORD, near READING, BERKS.

Telephone 0734 340333

We accept

Send large S.A.E. for your CATALOGUE PRICE 25P

### BUY NOW WHILE STOCKS LAST!

**TRANSFORMERS** British made transformers at very attractive prices.

Primary	Secondary	Current	1+	10+	100+
240v:	4.5-0-4.5v	400m/a	50p	45p	35p
240v:	6-0-6v	100m/a	58p	52p	43p
240v:	6-0-6v	500m/a	65p	60p	48p

(Postage & Packing: 45p per transformer or £1.60 per 10, £4.50 per 100)

These very high quality British made two pin European adaptors are ideal for driving Radios, cassette recorders, TV games, calculators etc. The adaptors fit in the UK shaver socket.

**EUROPEAN ADAPTORS**

REF	D.C. Voltage	Current	1+	10+	100+
EOB	4.5V	200m/a	50p	45p	32p
EM3	6V	200m/a	£1.00	80p	55p
EO9	6V	400m/a	£1.50	£1.25	85p

(Postage & Packing: 45p per adaptor or £1.60 per 10, £4.50 per 100)

Send now for our latest catalogue, 35p plus 30p P+P. Over 72 pages packed with complete range of components. Includes Special Offer list, order form and pre-paid envelope. Please add 15% VAT to the above prices.

**MARCO TRADING, DEPT. PE9,**  
THE MALTINGS, HIGH STREET, WEM, SHROPSHIRE, SY4 5EN.  
Tel: (0939) 32763

All orders despatched by return of mail.

### BENNING CROSS ELECTRONICS

67 Vicarage Road, Watford, Herts.  
Telephone WATFORD (0923) 36234

Export orders welcome - All deliveries within 7 days.  
Postage & Packaging 50p. Orders over £10 FREE  
No V.A.T. to add. Catalogue £1. Post FREE

**KITS**

No	Kit Description	Price
0	House Burglar Alarm Unit Very Loud + (Door-Window Switches 50p each)	£24.95
1	Electronic Continuity Tester	£6.45
2	Electronic Drill Speed Controller	£7.99
3	Ultrasonic Receiver Remote Switch	£8.95
4	Ultrasonic Transmitter Remote Switch	£8.95
5	Intercom Baby Alarm	£6.75
6	Electronic Metronome	£6.45
7	Sound Flash-Trigger	£12.25
8	B.F.O. Metal Locator	£7.95
9	Sound to Light Unit. Max 750 Watts	£6.95
10	Light Dimmer Module	£4.95
11	Variable Precision-Timer	£9.95
12	Model Train Speed Controller	£5.99
13	Electronic Touch-Switch	£8.95
14	3 Watts FM Transmitter. 85 to 115MHz	£7.95
15	250 MVV FM Transmitter. 100 to 106MHz	£3.50
16	Car Alarm Sensor Module. Built and Tested	£4.25
17	Siren Alarm Unit for above. Kit Speaker not incl.	£4.50
18	Deter Joynders. Engine Fault Simulator Kit	£2.25
19	General Purpose Alarm. Seat Belt Reminder etc. Kit	£4.95
20	Car Radio Aerial Booster FM/MVV. Built and Tested.	£4.95
21	Get ready for Winter. Ice Warning Alarm Kit	£3.95
22	Rear Window Heater Timer. Switches on when freezing, before you get into the car. Kit	£6.99
23	Towing a Trailer? Flasher Relay Kit with Warning Light. Output Relay, Warning Lamp, Cable and Connectors	£3.50 £1.99
23A	Relay Unit Only	
24	Relay as above. For cars fitted with Bulb Failure Devices. e.g. some Volvo's, Fiat's etc. Relay Unit only	£5.50
25	Zenon Timing Light Kit. Case and Cables not supplied	£9.95
26	Power Supply Module 240V AC in 9V 25mA out. 30x20mm	£1.25
27	Power Supply Module 240V AC in 12V 25mA out. 15 high + pins	£1.25
28	Remote Controlled Light Dimmer 300W. Complete Kit	£15.25

Many other kits available, send S.A.E. for lists.  
Ask for details:- Car Projects, Home Projects, Disco Lighting Projects, Games & Modelling Projects

**OR DETAILS IN CATALOGUE**

PCB's manufactured to your design, any quantity. S.A.E. with details please. Problems? Let us design your circuits. Details & your telephone number.

SPECIAL OFFERS		
	1 + 9	10 +
Memories 4116	65p	48p
TL209 L.E.D. Red	9p	7p
Green-Yellow	10p	8p
2N3055	40p	35p
BC108	9p	8p
NE555	16p	15p
741	14p	13p

### 16K RAM PACKS FOR ZX81 KIT ONLY £15.95

## BECOME A RADIO AMATEUR

Train now for the Radio Amateur Licence examination. No previous knowledge needed, only a few hours per week of home study for 3 to 6 months. Post coupon now for details or tel. 0734 51515 (24 hr service)

British National Radio & Electronics School Reading, Berks. RG1 1BR

FREE brochure without obligation from:-  
**British National Radio & Electronics School**  
READING, BERKS. RG1 1BR

ACCC

Name .....

Address .....

EE/9/84E BLOCK CAPS PLEASE





CALL IN AND SEE FOR YOURSELF

# AUDIO ELECTRONICS

ALL PRICES INCLUDE VAT

TEST EQUIPMENT CENTRES ALL MODELS ON DISPLAY OPEN SIX DAYS A WEEK

RETAIL • MAIL ORDER • EXPORT • INDUSTRIAL • EDUCATIONAL

## DIGITAL MULTIMETERS (UK C/P Free)



ALL MODELS 3 1/2 DIGIT UNLESS STATED



- HAND HELD** With free carry case
- KD25C 13 range 0.2A DC 2 meg ohm £24.95
  - KD30S 16 range 10A DC 2 meg ohm £29.95
  - KD30C 26 range 1A AC/DC 20 meg ohm £34.95
  - KD55C 28 range 10A AC/DC 20 meg ohm £39.95
  - 6010+ 28 range 10A AC/DC 20 meg ohm £34.40
  - 7030+ As 6010 but 0.1% basic £41.95
  - K0615 16 range 10A DC 2 meg plus Hfe tester £39.95
  - 189M 30 range 10A AC/DC 20 meg plus Hfe tester £69.95
  - H030 16 range 0.2A AC/DC 2 meg ohm £41.95
  - H030/8 As above plus cont. buzzer £44.50
  - H031 22 range 10A AC/DC 2 meg ohms plus cont buzzer £58.95
  - DM2350 = 21 range 10A AC/DC 20 meg ohm miniature hand held auto range £49.95
  - Beckman T100 34 range 10A AC/DC 20 meg ohm £56.35
- Beckman T110 As T100 plus Cont. test. etc.** £67.85
- Sifam 2200B 21 range 2A AC/DC 20 meg ohm** £39.95
- BENCH MODELS**
- TM353+ 27 range LCD 2A AC/DC £86.25
  - TM355+ 28 range LED 10A AC/DC £86.25
  - TM351+ 29 range LCD 10A AC/DC £113.85
  - \*Optional carry case £6.84
  - 2001 28 range LCD 10A AC/DC plus 5 range Cap. Meter with case £108.00
  - TM451 4% digit LCD every facility (0.02%) £171.00
  - 1503a 4% digit LCD every facility (0.05%) £171.00
  - 1503Ha 0.03% basic version of above £189.00
  - 1504 true RMS version £201.25
  - Sifam 2500 24 range LCD 2A AC/DC £99.95
  - Metrix (ITT) professional 3 1/2 + 4 1/2 digit OMM's standard & true RMS 4 models stocked £77.00 - £201.25

## FREQUENCY COUNTERS



- PFM200A MHz hand held pocket 8 digit LED £77.60
- 8110A 8 digit LED bench 2 ranges 100 MHz £77.00
- 8610B 9 digit LED bench 2 ranges 600 MHz £113.85
- 8000B 9 digit LED 3 ranges 1 GHz £178.00
- TF040 = 8 digit LCD 40 MHz £126.50
- TF200 = 8 digit LCD 200 MHz £166.75
- \*Optional carry case £6.84
- Pre-scalers - Extended range of most counters
- TP900 600 MHz £43.00
- TP1000 1 GHz £74.00

## SIGNAL GENERATORS (220/240v AC)



- FUNCTION:** All sine/square/triangle/TTL etc
- TG100 1 Hz - 100 KHz £90.00
  - TG102 0.2 Hz - 2 MHz £166.75
  - PULSE**
  - TG105 Various facilities 5 Hz - 5 MHz £97.75
  - AUDIO:** Multiband Sine/Square
  - LAG27 10 Hz to 1 MHz £90.85
  - AG202A 20 Hz to 200 KHz (List £94.50) £83.50
  - RF
  - SG402 100 KHz to 30 MHz (List £79.50) £69.50
  - LSG17 100 KHz to 150 MHz £79.35

## ELECTRONIC INSULATION TESTER

- YF 501 500 V/0-100m with carry case £63.00

## MULTIMETERS (UK C/P 65p)

- HM102 Z 20K/V 10A DC 22 range & cont. buzzer £13.50
- HM102Z 20 K/V 22 range & cont buzzer £14.95
- ETS500/5001 21 ranges, 50K/V, Range doubler, 10A DC. £18.95
- TMK500 23 ranges 30K/V, 12A DC plus cont. buzzer. £24.75
- NH56R 20K/V, 22 range pocket £10.95
- ETU102 14 range 2K/V pocket £6.50
- 830A 26 range 30K/V, 10A AC/DC overload protection, etc. £23.95
- 360TR 23 range 100K/V, Large scale 10A AC/DC plus Hfe £39.95
- AT1020 18 range 20K/V, Deluxe plus Hfe tester. £18.95
- YN 360TR 19 range 20K/V plus Hfe tester £15.95
- Matrix Professional multimeters in stock 3 models from £74.75

## VARIABLE POWER SUPPLIES (UK C/P £1.00)

- PP241 0/12/24V 0/1A £35.00
- PP243 3 amp version £59.95
- PS 1307S B/15V 7 amp twin meter £24.95

## DIGITAL THERMOMETER

- TK301 LCD -50 C to +750 with thermocouple £68.43

## AC CLAMP METER

- ST300 0/300A, 0/600 VAC, 0/1 Kohn 9 ranges With carry case (UK C/P 65p) £28.50

## LOGIC PROBES

- LP10 10 MHz £28.50
- DLP50 50 MHz with carry case and accessories £52.33

## OSCILLOSCOPES



- Full specification any model on request. SAE by post.
- HM Series HAMEG: SC THANDAR: CS TRI0: 3' CROTECH 'OT Safgan
  - SINGLE TRACE UK C/P £3.00
  - 3030 15 MHz 5mV, 95mm tube plus component tester C/P £3.00 £177.10
  - SC110A Miniature 10 MHz battery portable Post free £171.00
  - HM103 15 MHz 2mV, 6 x 7 display plus component tester C/P £3.00 £181.70
  - \*Optional carry case £6.84 AC adaptor £6.69 Nicads £12.50
  - DUAL TRACE (UK C/P £4.00)**
  - DT 520 Dual 20 MHz £241.50
  - HM203/4 Dual 20 MHz plus component tester £303.60
  - CS1562A Dual 10 MHz (List £321.00) £269.50
  - 3131 Dual 15 MHz - component tester £276.00
  - CS1566A Dual 20 MHz All facilities (List £401.35) £349.50
  - HM204 Dual 20 MHz plus component tester sweep delay £419.75
  - CS1820 Dual 20 MHz with extra facilities (List £508.30) £485.00
  - DX710 Metrix dual 15 MHz - component tester £304.75
  - OPTIONAL PROBE KITS**
  - X1 £7.95 X1 - X10 £10.50 X10 £9.45 X100 £16.95

## HIGH VOLTAGE METER

- Direct reading 0/40 KV 20K/Volt. (UK C/P 65p) £23.00

## DIGITAL CAPACITANCE METER

- 0.1 pF to 2000 mfd LCD 8 ranges OM6013 £52.75 (Carry case £2.95)

## TRANSISTOR TESTER

- Direct reading PNP, NPN, etc TC 1 (UK C/P 65p) £21.95

FREE CATALOGUE, SEND LARGE SAE (UK 20p)

**AUDIO ELECTRONICS** Cubegate Limited  
 301 EDGWARE ROAD, LONDON W2 1BN. TEL: 01-724 3564  
 ALSO AT HENRYS RADIO,  
 404/406 EDGWARE ROAD, LONDON, W2. TEL: 01-724 0323  
 HENRY'S COMPONENT SHOP, TEL: 01-723 1008

# SOLDERING/TOOLS

- ANTEX X5 SOLDERING IRON 25W £5.48
- SOLDERING IRON STAND £1.98
- SPARE BITS, Small, standard, large, 65p each For X5+X25
- SOLDER Handy size 99p
- SOLDER CARTON £1.84
- DESOLDER BRAID 69p
- HEAT SINK TWEEZERS 29p
- DESOLDER PUMP £6.48
- HOW TO SOLDER LEAFLET 12p
- LOW COST CUTTERS £1.89
- LOW COST LONG NOSE PLIERS £1.68
- WIRE STRIPPERS & CUTTERS £2.69
- PRECISION PETITE** £11.67
- 12V PCB DRILL £7.98
- DRILL STAND 50p
- GRINDING STONE 50p
- GRINDING WHEEL 50p
- SAW BLADE 85p
- BRASS WIRE BRUSH 50p
- BURR 50p
- VERO SPOT FACE CUTTER £1.49
- PIN INSERTION TOOL £1.98
- VEROPIPS (pk of 100) 0.1" 52p
- MULTIMETER TYPE 1 (1,000 opv) £5.48
- CROCODILE CLIP TEST LEAD SET, 10 leads with 20 clips 99p
- RESISTOR COLOUR CODE 21p
- CONNECTING WIRE PACK TYPE ED, 11 colours 40p
- ILLUMINATED MAGNIFIERS
- Small 2" dia. (5x mag) £1.14
- Large 3" dia. (4x mag) £2.40
- CAST IRON VICE £2.98
- SCREWDRIVER SET £1.98
- POCKET TOOL SET £3.98
- DENTISTS INSPECTION MIRROR £2.95
- JEWELLERS WEEGLASS £1.50
- PLASTIC TWEEZERS 69p

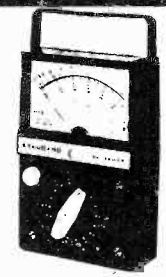

MULTIMETER TYPE 2. (YN360TR) 20K o.p.v. with transistor tester £14.75  
 AC + DC volts, DC current, 4 very useful resistance ranges. We've used it and we like it.



HELPING HANDS JIG £6.30  
 Heavy base. Six ball and socket joints allow infinite variation of clips through 360°. Has 2 1/2" diameter (2.5 magnifier attached), used and recommended by our staff.

PAIR OF PROBES WITH LEADS (incl.) 77p  
 Q MAX PUNCHES 3/8" £2.98; 1/2" £3.06; 5/8" £3.17; 3/4" 3.24.

- Speakers Min 8 ohm 87p; 64 ohm 89p; 80 ohm 98p.
- Crystal earpiece 65p
- Magnetic earpiece 15p
- Stethoscope attachment 69p
- Mono headphones £2.98
- Stereo headphones £4.35
- Telephone pickup coil 72p
- Min buzzer 6V 50p, 12V 65p. £6.40
- Euro breadboard £3.98
- 5 Dec breadboard £8.98
- Bimboard breadboard £4.20
- Verobloc breadboard £4.20
- PCB etching kit £4.98
- ZXB1 edge connector £2.25
- Ferrite rod 5 inch 59p
- PP3 clips 10p, PP9 clips 11p. £7.48
- 2 Station intercom 45p
- IC Sockets 8 pin 18p; 14 pin 17p; 16 pin 18p.
- Traditional Style Bell £1.75
- Public Address Mic 50K £4.40
- Mini Inset Crystal £1.29p
- Cassette Mic 45p
- Pillow Speaker 98p
- Horn Speaker 5 1/2" 8 ohm £6.75

# MAGENTA ELECTRONICS LTD.

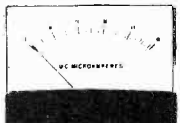

**METERS: 110 x 82 x 35mm**  
 30µA, 50µA, 100µA. £6.75. Post 50p.

**METERS: 45 x 50 x 34mm**  
 50µA, 100µA, 1mA, 5mA, 10mA, 25V, 1A, 2A, 5A 25V. £3.54. Post 30p.

**METERS: 60 x 47 x 33mm**  
 50µA, 100µA, 1mA, 5mA, 10mA, 100mA, 1A, 2A, 25V, 50V, 50-0-50µA, 100-0-100µA. £5.87. VU meters £5.87. Post on above meters 30p.

**Silicone grease 50g £1.32.**  
 Post 16p.

**NI-CAD BATTERY CHARGER**  
 Led indicators charge-test switch. For PP3, HP7, HP11 & HP2 size batteries. Price £5.85. Post 94p.

- UHF Aerial Amplifier 300-890MHz £6.03 post 57p
- 2 1/2" 8 ohm Speaker 46p post 21p
- 2 1/2" 64 ohm Speaker 56p post 21p
- Desoldering Pump £4.25 post 27p
- Resistance Substitution Box £3.97 post 17p

Vernier Dial 50mm Dia. £2.31 post 17p

Tape Head Demagnetizer £2.60 post 39p

Min. Buzzer 6 or 12V 63p post 21p

- TRANSFORMERS 240v Primary**
- 3-0-3v 100mA 82p
  - 6-0-6v 100mA 87p
  - 6-0-6v 250mA £1.21
  - 12-0-12v 50mA 87p
  - 12-0-12v 100mA 97p
  - 9-0-9v 75mA 87p
  - 9-0-9v 250mA £1.33
- Post on above transformers 48p.

- 9-0-9v 1A £2.00
- 12-0-12v 1A £2.50
- 15-0-15c 1A £2.95
- 6.3v 1 1/2A £2.00
- 6-0-6v 1 1/2A £2.20

Post on above transformers 94p.

All above prices include V.A.T. Send 80p for fully illustrated catalogue with 1983 price list. S.A.E. with all enquiries. Special prices for quantity quoted on request. For a new price list only send large s.a.e.

All goods despatched within 3 days from receipt of the order.

**M. DZIUBAS**  
 158 Bradshawgate, Bolton,  
 Lancs. BL2 1BA.

# E.E. PROJECT KITS

I.C.s  
TRANSISTORS RESISTORS  
CAPACITORS HARDWARE PCB's

# MAGENTA

Make us your No. 1 SUPPLIER OF KITS AND COMPONENTS FOR E.E. Projects. We supply carefully selected sets of parts to enable you to construct E.E. projects. Kits include ALL THE ELECTRONICS AND HARDWARE NEEDED. Printed circuit boards (fully etched, drilled and roller tinned) or Veroboard are, of course, included as specified in the original article, we even include nuts, screws and I.C. sockets. PRICES INCLUDE CASES unless otherwise stated. BATTERIES ARE NOT INCLUDED. COMPONENT SHEET INCLUDED. If you do not have the issue of E.E. which includes the project - you will need to order the instruction reprint at an extra 50p each. Reprints available separately 50p each + p. & p.

- STORAGE SCOPE INTERFACE FOR BBC MICRO August 83 less software £13.98  
PEDESTRIAN CROSSING SIMULATION BOARD August 83 no case £9.36  
HIGH POWER INTERFACE BOARD August 83 no case £9.44  
CAR INTRUDER ALARM August 83 £15.52  
TRI BOOST GUITAR TONE CONTROLLER July 83 £7.59  
AUTOMATIC GREENHOUSE WATERING SYS-TEM July 83 £9.98  
USER PORT I/O BOARD less cable + plug £9.54  
USER PORT CONTROL BOARD July 83 less cable + plug £22.86  
PULSE GENERATOR July 83 £34.97  
BINARY BANDIT GAME July 83 less case £9.98  
PROM PROGRAMMER Jun. 83 less software, TRS80 £40.99 Genie £41.58  
TRANSISTOR TESTER Jun. 83 £28.31  
ENVELOPE SHAPER Jun. 83 less case £11.21  
REAL TIME CLOCK Jun. 83 less software and cases

- Apple II £30.98 BBC £35.99 less power plug  
MODEL TRAIN CONTROLLER May 83 £25.17  
GUITAR HEADPHONE AMPLIFIER May 83 £27.20  
MW PERSONAL RADIO less case, May 83 £6.93  
LABORATORY AMPLIFIER May 83 £30.98  
MOISTURE DETECTOR March 83 £4.97  
CAR RADIO POWER BOOSTER April 83 £10.98  
FUNCTION GENERATOR April 83 £41.98  
FLANGER SOUND EFFECTS April 83 £21.98  
NOVELTY EGG TIMER April 83 less case £4.98  
ZX SPECTRUM AMPLIFIER April 83 £8.98  
DUAL POWER SUPPLY March 83 £25.98  
MULTISTATION INTERCOM March 83 master + 1 slave £43.02  
Extra slave £5.46  
BUZZ OFF March 83 £4.10  
CAR THERMOMETER March 83 £29.98  
SPEECH OSCILLATOR Feb. 83 £10.98  
PUSH BIKE ALARM Feb. 83 £11.32  
MOTOR BIKE ALARM Feb. 83 £14.46  
DOUBLE DICE Jan. 83 £10.82  
ELECTRONIC V/I METER Dec. 82 £11.38  
ZX TAPE CONTROL Nov. 82 £6.48  
PHOTO FINISH Nov. 82 £5.89  
SINE WAVE GEN Oct. 82 £14.65  
G. P. PRE-AMP Oct. 82 £5.64  
LIGHTS ON ALERT Oct. 82 £4.25  
CONTINUITY CHECKER Sept. 82 £4.97  
SOUND SPLITTER Sept. 82 £4.77  
SOUND RECOMBINER Sept. 82 £3.70  
SCREEN WASH DELAY Sept. 82 £4.48  
INSTRUMENT PRE AMP Aug. 82 £7.82  
TWO TONE DOORBELL ALARM Aug. 82, less case and bell transformer £8.82  
CB ROGER BLIPPER Aug. 82 £8.47  
2-WAY INTERCOM July 82 no case £4.11  
ELECTRONIC PITCH PIPE July 82 £4.91  
REFLEX TESTER July 82 £7.07  
SEAT BELT REMINDER Jun. 82 £3.73  
EGG TIMER Jun. 82 £4.98  
TWO TONE TRAIN HORN WITH REMOTE TRIGGER OPTION May 82 £11.26  
CAR LED VOLTMETER less case, May 82 £2.89  
LIGHTNING CHESS BUZZER May 82 £6.20  
V.C.O. SOUND EFFECTS UNIT Apr. 82 £11.56  
CAMERA OR FLASH GUN TRIGGER Mar. 82 £12.41 less tripod bushes  
POCKET TIMER Mar. 82 £3.71  
GUITAR TUNER Mar. 82 £15.63  
SIMPLE STABILISED POWER SUPPLY Jan. 82 £24.58  
MINI EGG TIMER, Jan. 82 £3.94  
SIREN MODULE Jan. 82 less speaker £5.57  
MODEL TRAIN CHUFFER Jan. 82 £8.27  
GUITAR ADAPTER Dec. 81 £3.76  
ELECTRONIC IGNITION Nov. 81 £25.98  
SIMPLE INFRA RED REMOTE CONTROL Nov. 81 £16.98  
PRESSURE MAT TRIGGER ALARM Nov. 81 £6.27 less mats

- EXPERIMENTER CRYSTAL SET Nov. 81 less aerial £5.99  
Headphones £2.98 extra  
CAPACITANCE METER Oct. 81 £23.51  
SUSTAIN UNIT Oct. 81 £12.76  
"POPULAR DESIGNS" Oct. 81 £4.57  
TAPE NOISE LIMITOR £2.52  
HEADS AND TAILS GAME £3.95  
PHOTO FLASH SLAVE £3.46  
FUZZ BOX £7.29  
OPTO ALARM £6.78  
SOIL MOISTURE UNIT £5.81  
ICE ALARM £7.89  
0-12V POWER SUPPLY Sept. 81 £17.98  
CMOS CAR SECURITY ALARM Sept. 81 £9.08  
CMOS DIE Sept. 81 £7.99  
CMOS METRONOME Aug. 81 £8.23  
COMBINATION LOCK July 81 less case £19.58  
BURGLAR ALARM SYSTEM Jun. 81 less bell, loop & Mic's £40.98  
LIGHTS REMINDER AND IGNITION LOCATOR E.E. May 81 £5.66  
SOIL MOISTURE INDICATOR E.E. May 81 £6.61  
GUITAR HEADPHONE AMPLIFIER E.E. May 81 £4.23  
PHONE BELL REPEATER/BABY ALARM E.E. May 81 £5.66  
INTERCOM April 81 £22.23  
SIMPLE TRANSISTOR & DIODE TESTERS Mar. 81 Ohm meter version £2.73  
LED version £2.73  
MINI SIREN Mar. 81 £8.04  
LED DICE Mar. 81 £8.44  
LED FLASHER Mar. 81 £4.29  
MODULAR TONE DOORBELL Mar. 81 £6.64  
POWER SUPPLY Mar. 81 £53.47  
THREE CHANNEL STEREO MIXER Feb. 81 £18.69  
SIGNAL TRACER Feb. 81 £8.17 less probe  
NI-CD BATTERY CHARGER Feb. 81 £13.61  
ULTRASONIC INTRUDER DETECTOR Jan. 81 less case £53.47  
2 NOTE DOOR CHIME Dec. 80 £10.32  
LIVE WIRE GAME Dec. 80 £11.70  
GUITAR PRACTICE AMPLIFIER Nov. 80 £12.82 less case  
Standard case £3.88 High quality case £8.33  
SOUND TO LIGHT Nov. 80 3 channel £21.34  
TRANSISTOR TESTER Nov. 80 £11.63 inc. test leads  
AUDIO EFFECTS UNIT FOR WEIRD SOUNDS Oct. 80 £13.11  
BICYCLE ALARM Oct. 80 £10.35 less mounting brackets

- \*\*\*\*\*  
FUN WITH ELECTRONICS  
Enjoyable introduction to electronics. Full of very clear full colour pictures and easy to follow text. Ideal for all beginners - children and adults. Only basic tools needed. 64 full colour pages cover all aspects - soldering - fault finding - components (identification and how they work).  
Also full details of how to build 6 projects - burglar alarm, radio, games, etc. Requires soldering - 4 pages clearly show you how.  
COMPONENTS SUPPLIED ALLOW ALL PROJECTS TO BE BUILT AND KEPT.  
Supplied less batteries & cases.  
\*\*\*\*\*  
FUN WITH ELECTRONICS  
COMPONENT PACK £15.78  
BOOK EXTRA £1.25.  
Book available separately.  
\*\*\*\*\*

## BOOKS: ELECTRONICS & COMPUTING

- First Book of Hi-Fi Loudspeaker Enclosures 95p  
28 Tested Transistor Projects £1.25  
50 Projects Using IC CA3130 £1.25  
A Practical Introduction to Digital IC's £1.25  
How to Build Advanced Short Wave Receivers £1.95  
Essential Theory for the Electronics Hobbyist £1.95  
50 (FET) Field Effect Transistor Projects £1.75  
How to Design and Make Your Own PCB's £1.95  
Fun with Electronics £1.25  
50 Simple L.E.D. Circuits £1.50  
How to Make Walkie-Talkies £1.95  
Projects in Opto-Electronics £1.95  
Mobile Disobey Handbook £1.35  
Electronic Projects for Beginners £1.95  
Popular Electronic Projects £1.95  
Electronic Security Devices £1.95  
50 Circuits Using 7400 Series IC's £1.75  
Second Book of CMOS IC Projects £1.50  
Beginners Guide to Digital Techniques 95p  
Transistor Radio Fault-Finding Chart 50p  
Electronic Household Projects £1.75  
Electronic Test Equipment Construction £1.75  
Practical Computer Experiments £1.75  
Radio Control for Beginners £1.95  
Popular Electronic Circuits - Book 1 £1.95  
Electronic Synthesiser Projects £1.75  
Electronic Projects Using Solar Cells £1.95  
International Transistor Equivalents Guide £2.95  
Simple L.E.D. Circuits - Book 2 £1.95  
Easy Electronics - Crystal Set Construction £1.75  
Electronic Projects for Cars and Boats £1.95  
Popular Electronic Circuits - Book 2 £2.25  
How to Identify Unmarked IC's 65p  
Multi-Circuit Board Projects £1.95  
International Diode Equivalents Guide £2.25  
The Art of Programming the 1K X81 £1.95

- The Art of Programming the 16K ZX81 £2.50  
The Art of Programming the ZX Spectrum £2.50  
Semiconductor Data Book Newnes £6.95  
Basic Electronics. Theory and practice £7.98  
Microprocessors for Hobbyists £4.75  
Burglar Alarm Systems £5.55  
Electronics, Build and Learn £3.90  
Electronic Projects in Music £5.98  
Electronic Projects in Photography £3.90  
Electronic Projects for Home Security £3.90  
Questions and Answers Electronics £2.70  
Electronic Projects in the Car £3.90  
20 Solid State Projects Car and Garage £4.80  
110 Electronic Alarm Projects £5.98  
Computing is Easy £4.25  
ZX81 Users Handbook £5.75  
ZX81 Basic Book £5.75  
50 CMOS IC Projects £1.35  
52 Projects using IC741 £1.25  
IC555 Projects £1.95  
IC LM3900 Projects £1.35  
Single IC Projects £1.50  
Electronic Games £1.75  
A Microprocessor Primer £1.75  
Remote Control Projects £1.95  
Electronic Music Projects £1.75  
Power Supply Projects £1.75  
VMOS Projects £1.95  
Digital IC Projects £1.95  
How to use Op-Amps £2.25  
Audio Projects £1.95  
Electronic Timer Projects £1.95  
Model Railway Projects £1.95  
IC Projects for Beginners £1.95  
Mini Matrix Board Projects £1.95  
Aerial Projects £1.95  
Modern Op-Amp Projects £1.95  
The Pre-Computer Book £1.95

- Handbook of Integrated Circuits (IC's) Equiv. & Substitutes £1.95  
Solid State Short Wave Receivers for Beginners £1.25  
Beginners Guide to Building Electronic Projects £1.95  
First Book of Transistor Equivalents and Substitutes £1.50  
Second Book of Transistor Equivalents and Substitutes £1.75  
Chart of Radio, Electronic, Semi-conductor and Logic Symbols 50p  
How to Build Your Own Metal and Treasure Locators £1.50  
50 Circuits Using Germanium, Silicon and Zener Diodes £1.50  
50 Projects Using Relays, SCR's and TRIACS £1.95  
Electronic Music and Creative Tape Recordings £1.95  
Practical Electronics Calculations and Formulae £2.95  
How to Build Your Own Solid State Oscilloscope £1.95  
Practical Construction of Pre-amps, Tone Controls, Filters & Attn. £1.95  
Beginners Guide to Microprocessors and Computing £1.75  
Counter, Driver and Numerical Display Projects £1.75  
An Introduction to BASIC Programming Techniques £1.95  
30 Solderless Breadboard Projects - Book 1 £2.25  
How to Get Your Electronic Projects Working £1.95  
Practical Electronic Building Blocks - Book 1 £2.25  
Practical Electronic Building Blocks - Book 2 £1.95  
Elementary Electronics. Sladdin. Excellent theory and 35 constructional projects. Uses S-Dec. First steps to CSE level. £3.98  
Interfacing to Microprocessors and Microcomputers £5.75

- AY3-8912 i.c. £5.98  
ZX81 edge connector £2.25  
ZX81 edge plug £1.50  
ZX Spectrum edge connector £2.55

SINCAIR  
SOUND BOARD KIT  
AS JUNE 83 H.E.  
complete (less case)  
£18.98  
Reprint extra 45p.

### ZX SPECTRUM AMPLIFIER

250mW output. Volume control. Internal speaker. Very simply connected using load/save lead. Puts real power even into the simplest "Beep" commands. Adds a real "zing" to musical programs and games. Requires PP3 battery - not supplied. Very low current drain. Supplied ready built complete with demo software and instructions.

ORDER AS: ZX SPECTRUM AMPLIFIER (SAE) £6.98

### ZX SPECTRUM SUPER AMPLIFIER

250mW output. Now add synthesizer quality to those "Beep" commands. Super circuit with adjustable ATTACK, SUSTAIN and DECAY envelope controls. Plus variable ECHO. Generates a wide range of special effects. Five graduated controls. Internal speakers. Very smart case. Requires batteries - not supplied. Very low current drain. Ready built complete with demo software and instructions.

ORDER AS: ZX SPECTRUM SUPER AMPLIFIER (SSAE) £17.98

### TEACH-IN 82

All top quality components as specified by E.E. FREE COMPONENT IDENTIFICATION SHEET. Follow this educational series and learn about electronics. List 1 & 2 £27.98 List 3 £5.98 ALL 3 TOGETHER £33.48 WOODEN CASE KIT £11.98

### INTRODUCING ELECTRONICS

INTRODUCING ELECTRONICS 6 part series E.E. Oct. 82-Mar. 83. No soldering. Connections via screw terminal blocks. Very clear drawings showing how to connect components. Covers the basis of electronics. Components (less batteries) parts 1-6 £6.98. Reprints 45p each extra

### ADVENTURES WITH DIGITAL ELECTRONICS

Entertaining and instructive. Includes details of some digital IC's and 8 projects, shooting gallery, 2 way traffic lights, electronic adder, computer space invaders game etc. No soldering. Adventures with Digital Electronics Book £2.25 Component pack including Breadboards £42.50 less batteries

### ADVENTURES WITH MICROELECTRONICS

Similar to 'Electronics' below. Uses I.C.s. Includes dice, electronic organ, doorbell, reaction timer, radio etc. Based on Bimboard 1 bread board. Adventures with Microelectronics £2.98 Component pack £29.64 less battery.

### ADVENTURES WITH ELECTRONICS

An easy to follow book suitable for all ages. Ideal for beginners. No soldering, uses an S-Dec Breadboard. Gives clear instructions with lots of pictures. 16 projects - including three radios, siren, metronome, organ, intercom, timer, etc. Helps you learn about electronic components and how circuits work. Component pack includes an S-Dec breadboard and all the components for the projects. Adventures with Electronics £2.85. Component pack £18.98 less battery.

### 30 SOLDERLESS BREADBOARD PROJECTS

Book 1 by R. A. Penfold  
Clear verbobic layouts and circuit diagrams. Includes fuzz box, radio, metronomes, timers transistor checker, switches, etc. Introduction gives basic information on components including resistors, capacitors, I.C.s transistors, photocells etc. Ideal for beginners as well as those with some experience. Complete kit including verbobic, book and components (less batteries) £24.75. Less book £22.50, less verbolic £20.25. Book only £2.25.

### MORE KITS AND COMPONENTS IN OUR LISTS

FREE PRICE LIST  
Price list included with orders or send see (9 x 4) CONTAINS LOTS MORE KITS, PCB's & COMPONENTS

### ELECTRONICS CATALOGUE

Illustrations, product descriptions, circuits all included. Up-to-date price list enclosed. All products are stock lines for fast delivery.  
Send 80p in stamps or add 80p to order.  
Free to Schools/Colleges requested on official letterhead.

MAGENTA gives you FAST DELIVERY OR QUALITY COMPONENTS & KITS. All products are stock lines and are new & full specification. We give personal service & quality products to all our customers - HAVE YOU TRIED US?

### MAGENTA ELECTRONICS LTD.

EP54, 135 HUNTER ST., BURTON-ON-TRENT STAFFS, DE14 2ST. MAIL ORDER ONLY. 0283 65435, Mon-Fri 9-5. Access/Barclaycard (Visa) by phone or post.

Add 50p p&p to all orders. Prices include VAT. See all enquiries. Official orders welcome. OVERSEAS: Payment must be sterling. IRISH REPUBLIC and BFPO. UK PRICES. EUROPE: UK PRICES plus 10% ELSEWHERE: write for quote.





# BI-PAK BARGAINS

## TRIACS - PLASTIC

4 AMP - 400V - T022 - TAG 136G	
1 OFF	100 OFF
40p	£3.75
8 AMP - 400V - T0220 - TAG 425	£30.00
60p	£5.75

## MINIATURE FM TRANSMITTER

Freq: 95-106MHz. Range: 1/2 mile  
Size: 45 x 20mm Add: 9v batt. **ONLY £5.50**  
Not licenced in U.K.  
ideal for: 007-M15-FBI-CIA-KGB etc.

## PROGRAMMABLE UNIJUNCTION TRANSISTOR

PUT case T0106 plastic MEU22 Similar to 2N6027/  
6028 PNP Silicon  
Price: 1-9 10-49 50-99 100+  
Each 20p 18p 15p 13p  
Normal Retail Price £0.35 each.

## VALUE PACKS

Pak No.	Qty	Description	Price
VP1	300	Assorted Resistors Mixed Types	£1.00
VP2	300	Carbon Resistors 1/4 Watt Pre-Formed	£1.00
VP3	200	1/4 Watt Min Carbon Resistors Mixed	£1.00
VP4	150	1/2 Watt Resistors 100 ohm - 1M Mixed	£1.00
VP5	200	Assorted Capacitors All Types	£1.00
VP6	200	Ceramic Caps Miniature - Mixed	£1.00
VP7	100	Mixed Ceramics Disc. 1pf - 56pf	£1.00
VP8	100	Mixed Ceramic Disc. 68pf - 015pf	£1.00
VP9	100	Assorted Polyester/Polystyrene Capas	£1.00
VP10	60	C280 Type Caps Metal Foil Mixed	£1.00
VP11	100	Electrolytics - All Sorts	£1.00
VP12	60	Bead Type Polystyrene Min Caps	£1.00
VP13	50	Silver Mica Caps Ass. 5.6pf - 150pf	£1.00
VP14	50	Silver Mica Caps Ass. 180pf - 4700pf	£1.00
VP15	50	High Voltage Disc. Ceramic 750v - 8kv Mixed	£1.00

## VALUE PACKS

Pak No.	Qty	Description	Price
VP16	50	Wirewound Res. 9W (avg) Ass. 1 ohm - 12K	£1.00
VP17	50	Metres PVC Covered Single Strand Wire Mixed Colours	£1.00
VP18	30	Metres PVC Covered Multi Strand Wire Mixed Colours £1.00	£1.00
VP19	40	Metres PVC Single/Multi Strand Hook-Up Wire Mixed	£1.00
VP20	6	Rocker Switches 5 Amp 240v	£1.00
VP21	20	Pcs. 1 - 2 & 4 mm Plugs & Sockets Matching Sizes	£1.00
VP22	200	Sq. Inches Total Copper Clad Board Mixed Sizes	£1.00

## VALUE PACKS

Pak No.	Qty	Description	Price
VP23	20	Assorted Slider Pots. Mixed Values	£1.00
VP24	10	Slider Pots. 40 mm 22K 5 x Log 5 x Lin	£1.00
VP25	10	Slider Pots. 40 mm 47K 5 x Log 5 x Lin	£1.00
VP26	20	Small .125" Red LED'S	£1.00
VP27	20	Large .2" Red LED'S	£1.00

## TRANSISTOR CLEARANCE

All Sorts Transistors. A mixed Bag NPN-PNP Silicon & Germ. Mainly Uncoded You To Sort Pack Includes Instructions For Making Simple Transistor Tester. Super Value. Order No VP60 **£1.00**

## SEMICONDUCTORS FROM AROUND THE WORLD

**100** A collection of Transistors, Diodes, Rectifiers & Bridges SCRs, Triacs, I.C.'s & Opto's all of which are current every-day useable devices.

Guaranteed Value Over £10 Normal Retail Price.

Data etc in every pack. Order No. VP56 **Our Price £4.00**

## VALUE PACKS

Pak No.	Qty	Description	Price
VP28	10	Rectangular 2" Green LED'S	£1.00
VP29	30	Ass. Zener Diodes 250mW - 2W Mixed Vts. Coded	£1.00
VP30	10	Ass. 10W Zener Diodes Mixed Vts. Coded	£1.00
VP31	10	5 Amp SCR'S TO-66 50-400v Coded	£1.00
VP32	20	3 Amp SCR'S TO-66 Up To 400v Uncoded	£1.00
VP33	200	Sil. Diodes Switching Like IN4148 D0-35	£1.00
VP34	200	Sil. Diodes Gen. Purpose Like OA200/BAX13/16	£1.00
VP35	50	1 Amp IN4000 Series Sil. Diodes Uncoded All Good	£1.00
VP36	8	Bridge Rects. 4 x 1 Amp 4 x 2 Amp Mixed Vts. Coded	£1.00
VP37	8	Black Instrument Type Knobs With Pointer 1/2 Std	£1.00
VP42	10	Black Heatsinks To Fit TO-3, TO-220 Ready Drilled	£1.00
VP43	4	Power-Fin Heatsinks 2 x TO-3 2 x TO-66 Size	£1.00
VP44	1	Large Power Heatsink 90 x 80 x 35 mm Drilled For Up To 4 TO-3 Devices	£1.00
VP45	50	BC107/8 Type NPN Transistors Good Gen. Purpose Uncoded	£1.00
VP46	50	BC177/8 Type PNP Transistors Good Gen. Purpose Uncoded	£1.00
VP47	10	Silicon Power Trans. Similar 2N3055 Uncoded	£1.50

## BI-PAK SOLDER - DESOLDER KIT

Kit comprises: DRÖER ND. VP80  
1 High Quality 25 watt General Purpose Lightweight Soldering Iron 240v mains incl 3/16" (4.7mm) bit.  
1 Quality Desoldering Pump High Suction with automatic ejection knurled anti-corrosive casing and Teflon nozzle  
1.5 metres of De-Soldering braid on plastic dispenser  
2 vds (1.83m) Resin Cored Solder on Card  
1 Heat Shunt tool tweezer Type  
Total Retail Value over £12.00  
**OUR SPECIAL KIT PRICE £9.95**



## BI-PAK PCB ETCHANT AND DRILL KIT

Complete PCB Kit comprises  
1 Expo Mini Drill 10,000RPM 12v DC incl 3 collets & 3 x Twist Bits  
1 Sheet PCB Transfers 210mm x 150mm  
1 Etch Resist Pen  
1 jib pack FERRIC CHLORIDE crystals  
3 sheets copper clad board  
2 sheets Fibreglass copper clad board  
Full instructions for making your own PCB boards  
Retail Value over £15.00  
**OUR BI-PAK SPECIAL KIT PRICE £9.95**  
ORDER NO. VP81



## BI-PAK'S OPTO SPECIAL

A selection of large and small sized LED's in various shapes, sizes & colours, together with 7 Segment Displays both anode & cathode plus photo transistors emitters and detectors. Cadmium Cell ORP12 and Germ. photo transistor OCP71 included. In all a total of 25 Opto pieces valued over £12 Normal Price

Order No. VP57  
**Our Super Value Price Just £5.00**



## DIGITAL VOLT METER MODULE

3 x 7 segment displays Basic Circuit. 0-2v - instructions provided to extend voltage & current ranges Operating voltage 9/12v. Typ. Power Consumption 50mA  
O/No. VP99 **Once only price £9.95**

## SINGLE SIDED FIBREGLASS BOARD

Order No	Pieces	Size	Sq. Ins	Price
FB1	4	9 x 23"	100	£1.50
FB2	3	11 x 3"	100	£1.50
FB3	4	13 x 3"	156	£2.00

## DOUBLE SIDED FIBREGLASS BOARD

Order No	Pieces	Size	Sq. Ins	Price
FB4	2	14 x 4"	110	£2.00

## SILICON BRIDGE RECTIFIERS

Comprising 4 x 1/2 Amp rectifiers mounted on PCB. VRM - 150 vits IFM - 1.5 Amps

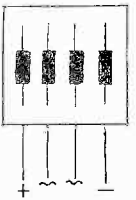

Size: 1 inch square  
10 off £1.00  
50 off £4.50  
100 off £7.50

ORDER NO: 4R1 B Rect.

## HYBRID LED COLOUR DISPLAYS

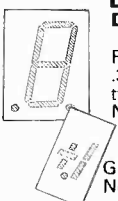

Red, Green, Yellow - .37/.5/.6 inch Mixed types and colours  
**NUMERIC & OVER-FLOW** Common Anode/Cathode.  
GaAsP/GaP. Brand New, Full Data incl.

10 pieces (our mix) **£4.00**  
Normal Retail Value Over £10.00  
Order No. VP58

## IC BARGAINS

VP40	30	Assorted 74 Series TTL I.C.'s Gates, Flip-Flops & M.S.I.'s + Data Book. All New, Normal Retail Value Over £6.00. Our Price	<b>£2.50</b>
VP41	30	Assorted CMOS I.C.'s CD4000 Series. Pack Includes: 00/09/12/14/18/21/23/25/28/30/35/44/68 AY/AE Types Plus Data Sheet Value Over £8.00. Normal retail	<b>£2.50</b>

YOU MAY ORDER any ONE TYPE of the above CMOS at £2.00 per 25 pieces. ORDER AS VP41 + type number required.

## RATCHET SCREWDRIVER KIT

Comprises 2 standard screwdriver blades 5 & 7mm size. 2 cross point size 4 & 6. 1 Ratchet handle. 5-in-1 Kit **£1.45 each.** O/No 329B

## INTRUSION ALARM

The DOOR BIRD DB 2000 alerts you before your door is opened. Just hang on the inside door knob - alarm is activated as soon as the outside door knob is touched.

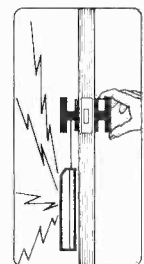

**ONLY £3.95**

## OUR GREAT NEW CATALOGUE

Presented with a Professional Approach and Appeal to ALL who require Quality Electronic Components, Semiconductors and other Accessories ALL at realistic prices. There are no wasted pages of useless information so often included in Catalogues published nowadays. Just solid facts i.e. price, description and individual features of what we have available. But remember, BI-PAK's policy has always been to sell quality components at competitive prices and THAT WE STILL DO.

We hold vast stocks "in stock" for fast immediate delivery, all items in our Catalogue are available ex stock. The Catalogue is designed for use with our 24 hours "ansaphone" service and the Visa/Access credit cards, which we accept over the telephone.

To receive your NEW 1983 BI-PAK Catalogue, send 75p PLUS 25p p&p to:-

## SILICON NPN! Type Transistors

TO-92 Plastic Centre Collector Like BC182L - 183L - 184L  
VCBO 45 VCEO 30 IC200mA Hfe 100-400  
All perfect devices - uncoded. ORDER AS SX183L

50 off	100 off	500 off	1000 off
£1.50	£2.50	£10.00	£17.00

Silicon General Purpose NPN Transistors  
TO-18 Case. Lock fit leads - coded CV7644 similar to BC147 - BC107 - ZT89 ALL NEW VCE 70v IC500mA ORDER AS CV7644

50 off	100 off	500 off	1000 off
£2.00	£3.80	£17.50	£30.00

Silicon General Purpose PNP Transistors  
TO-5 Case. Lock fit leads coded CV9507 similar 2N2905A to BFX30 VCEO IC600mA Min HFE 50. ALL NEW. ORDER AS CV9507

50 off	100 off	500 off	1000 off
£2.50	£4.00	£19.00	£25.00

## VP38 100 Silicon NPN Transistors - All Perfect. Coded Mixed. Types With Data And Evt. Sheet No Rejects Real Value

**£3.00**

## VP39 100 Silicon PNP Transistors - All Perfect. coded Mixed. Types With Data And Evt. Sheet No Rejects Real Value

**£3.00**

2N3055 The best known Power Transistor in the world - 2N3055 NPN 115w. Our Bi-Pak Special Offer Price  
10 off **£3.50**  
50 off **£16.00**  
100 off **£30.00**

B0312 COMPLIMENTARY PNP POWER TRANSISTORS TO 2N3055. Equivalent MJ2955 - B0312 - T03. Special price **£0.70** ea  
10 off **£6.50**

# BI-PAK

Send your orders to Dept. EE9 BI-PAK PO BOX 6, WARE, HERTS.  
SHOP AT 3 BALDOCK ST., WARE, HERTS.  
TERMS: CASH WITH ORDER. SAME DAY DESPATCH. ACCESS, BARCLAYCARD ALSO ACCEPTED. TEL (0920) 3182. GIRO 389 7006.  
ADD 15% VAT AND 75p PER ORDER POSTAGE AND PACKING.



Use your credit card. Ring us on Ware 3182 NOW and get your order even faster. Goods normally sent 2nd Class Mail. Remember you must add VAT at 15% to your order.  
Total Postage add 75p per Total order.



Here's a selection from our vast stocks. Full price list free on request. Orders by phone quoting credit card no. or by mail order. Callers welcome. All products first grade franchised source. All in-stock items dispatched same day. Official orders welcome from Govt Dept's, schools, etc. Please add 60p p&h + 15% VAT. Overseas orders no VAT but allow £2.00 min p&h. Quantity discounts negotiable.

TRY US NOW - WE'VE GOT WHAT YOU NEED.

Table of electronic components including Resistors, Wire & Cable, Diodes, Thyristors, Diacs, Transistors, and various other parts with their respective specifications and prices.

Table of electronic components including Diodes, Thyristors, Diacs, Transistors, and various other parts with their respective specifications and prices.

LOGIC

MEMORIES

CMOS

LINEAR ICs

SCRs, TRIACS, DIACS

THYRISTORS

TRICAPS

TO220 CASE

DIACS

ZENER DIODES

BRIDGE RECTIFIERS

SWITCHES

Step-by-step fully illustrated assembly and fitting instructions are included together with circuit descriptions. Highest quality components are used throughout.

# Sparkrite

BRANDEADING ELECTRONICS  
NOW AVAILABLE IN KIT FORM

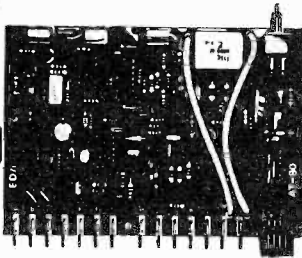
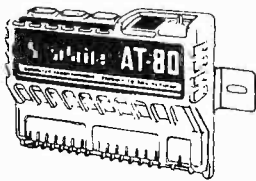

## AT-80 Electronic Car Security System

- Arms doors, boot, bonnet and has security loop to protect fog/spot lamps, radio/tape, CB equipment
- Programmable personal code entry system
- Armed and disarmed from outside vehicle using a special magnetic key fob against a windscreen sensor pad adhered to the inside of the screen
- Fits all 12V neg earth vehicles
- Over 250 components to assemble

## VOYAGER Car Drive Computer

- A most sophisticated accessory
- Utilises a single chip mask programmed microprocessor incorporating a unique programme designed by EDA Sparkrite Ltd.
- Affords 12 functions centred on Fuel, Speed, Distance and Time
- Visual and Audible alarms warning of Excess Speed, Frost/Ice, Lights-left-on
- Facility to operate LOG and TRIP functions independently or synchronously
- Large 10mm high 400ft-L fluorescent display with auto intensity
- Unique speed and fuel transducers giving a programmed accuracy of + or - 1%
- Large LOG & TRIP memories, 2,000 miles, 180 gallons, 100 hours
- Full Imperial and Metric calibrations
- Over 300 components to assemble
- A real challenge for the electronics enthusiasts!

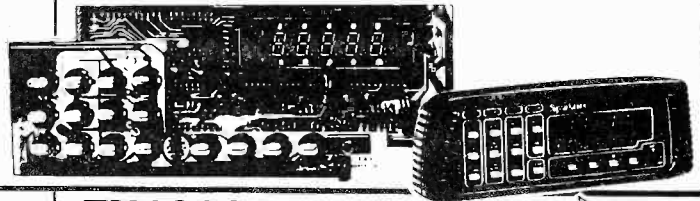

## SX1000 Electronic Ignition

- Inductive Discharge
- Extended coil energy storage circuit
- Contact breaker driven
- Three position changeover switch
- Over 65 components to assemble
- Patented clip-to-coil fitting
- Fits all 12v. neg. earth vehicles

## TX1002 Electronic Ignition

- Contactless or contact triggered
- Extended coil energy storage circuit
- Inductive Discharge
- Three position changeover switch
- Distributor triggerhead adaptors included
- Die cast weatherproof case
- Clip-to-coil or remote mounting facility
- Fits majority of 4 & 6 cyl. 12V. neg. earth vehicles
- Over 145 components to assemble

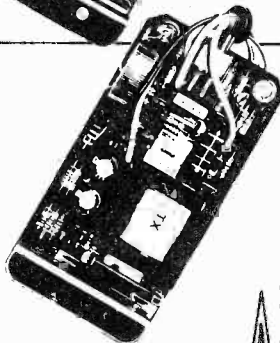

## SX2000 Electronic Ignition

- The brandleading system on the market today
- Unique Reactive Discharge
- Combined Inductive and Capacitive Discharge
- Contact breaker driven
- Three position changeover switch
- Over 130 components to assemble
- Patented clip-to-coil fitting
- Fits all 12v neg. earth vehicles

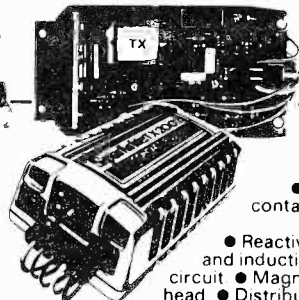

## TX2002 Electronic Ignition

- The ultimate system
- Switchable contactless
- Three position switch with Auxiliary back-up inductive circuit
- Reactive Discharge. Combined capacitive and inductive.
- Extended coil energy storage circuit
- Magnetic contactless distributor triggerhead
- Distributor triggerhead adaptors included
- Can also be triggered by existing contact breakers
- Die cast waterproof case with clip-to-coil fitting
- Fits majority of 4 and 6 cylinder 12v neg. earth vehicles
- Over 150 components to assemble

All SPARKRITE products and designs are fully covered by one or more World Patents

## SPECIAL OFFER

"FREE" MAGIDICE KIT WITH ALL ORDERS OVER £45.00

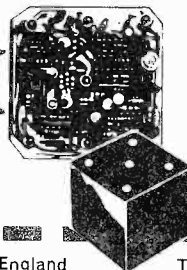

## MAGIDICE Electronic Dice

- Not an auto item but great fun for the family
- Total random selection
- Triggered by waving of hand over dice
- Bleeps and flashes during a 4 second tumble sequence
- Throw displayed for 10 seconds
- Auto display of last throw 1 second in 5
- Muting and Off switch on base
- Hours of continuous use from PP7 battery
- Over 100 components to assemble

Sparkrite, 82 Bath Street, Walsall, West Midlands.

SPARKRITE 82 Bath Street, Walsall, West Midlands, WS1 3DE England

Tel: (0922) 614791 Allow 28 days for delivery

	SELF ASSEMBLY KIT
SX 1000	£12.95
SX 2000	£19.95
TX 1002	£22.95
TX 2002	£32.95
AT 80	£32.95
VOYAGER	£64.95
MAGIDICE	£9.95

PRICES INC. VAT POSTAGE & PACKING

NAME \_\_\_\_\_ EE/9/83  
ADDRESS \_\_\_\_\_

I ENCLOSE CHEQUE(S)/POSTAL ORDERS FOR

£ \_\_\_\_\_ KIT REF \_\_\_\_\_

CHEQUE NO \_\_\_\_\_

PHONE YOUR ORDER WITH  
SEND ONLY SAE IF BROCHURE IS REQUIRED



BRANDEADING BRITISH ELECTRONICS  
CUT OUT THE COUPON NOW!

# EVERYDAY ELECTRONICS and computer PROJECTS

VOL. 12 NO. 9 SEPTEMBER 1983

## Editor

F. E. BENNETT

## Assistant Editor

B. W. TERRELL B.Sc.

## Production and News Editor

D. G. BARRINGTON

## Projects Editor

G. P. HODGSON

## Technical Sub-Editor

R. A. HOOPER

## Art Editor

R. F. PALMER

## Assistant Art Editor

P. A. LOATES

## Technical Illustrator

D. J. GOODING Tech. (CEI)

## Secretary

JACQUELINE DOIDGE

## Editorial Offices

KING'S REACH TOWER  
STAMFORD STREET  
LONDON SE1 9LS  
Phone: 01-261 6873

## Advertisement Manager

R. SMITH  
Phone: 01-261 6671

## Representative

R. WILLET  
Phone: 01-261 6865

## Classified Supervisor

B. BLAKE  
Phone: 01-261 5897

## Make-Up and Copy Department

Phone: 01-261 6615

## Advertisement Offices

KING'S REACH TOWER  
STAMFORD STREET  
LONDON SE1 9LS

## BUILDING FOR THE FUTURE

WHERE are all the girls? This was one question raised at the SEDAC '83 Presentation Ceremony last June. For although two school-girls were amongst the students of the twelve-finalist teams, no girls' school, as such, had entered this National Competition for schools sponsored by Mullard and this magazine.

Handling a soldering iron and pliers might be considered an inappropriate pursuit for girls—until one remembers their older sisters who in their thousands are employed in industry assembling electronic equipments.

Perhaps the computer has more appeal to the younger members of the fair sex? But here we discover an equally depressing situation. Girls, it is proved by national statistics, are not so eager as boys to get their fingers onto computer keyboards and four times as many boys as girls take A-level computer science. Strange again, when one considers the similarity between typewriters and computers from the users stand-point, and the overlapping that already occurs in the business office where secretaries and typists are becoming involved quite naturally with word processors and even microcomputers.

This lack of interest in computer science by girls is indeed serious and it is worrying national bodies such as the Engineering Council, the Equal Opportunities Commission and the Microelectronics Education Programme. Naturally there are exceptions to the rule, and we are pleased to show students of one London girls' school carrying out experiments with a computer, see *Computer Aided Experiments*, page 600.

Electronics and computers represent the two major growth areas in our economy—and significantly both areas are healthy despite the impoverished state of many older industries. The message for the future is there—but somehow it is not being received, or at any rate acted upon, by all those entrusted with the education of our children. It's the old story: the humanities all too often take precedence over the sciences. Many SEDAC finalists told us that the initiative to enter the Competition came from themselves and much (sometimes all) of the project work was done outside school, the school authorities taking a belated interest only when their students had won through to the final stage.

We do not have to accept passively this situation. Self-help is after all a virtue strongly advocated by our government, and it can be applied very effectively here. Wise and responsible parents do counsel their children in career matters and those who follow electronics, whether professionally or as a hobby, will appreciate the opportunities arising from electronics in general and microcomputers in particular. A home study course in electronics could initiate a youngster into the "mysteries" of the subject and infuse genuine interest leading to more extensive study.

Our twelve-part series *Teach-In 84* will meet this need very satisfactorily. We commend it to all parents, and of course to the younger people themselves. *Teach-In 84* starts next month. It could make a lot of difference to the job prospects of lots of young people due to enter the labour market in the next few years.

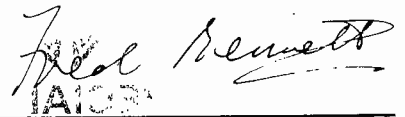

Fred Bennett  
AICD

## Readers' Enquiries

We cannot undertake to answer readers' letters requesting modifications, designs or information on commercial equipment or subjects not published by us. All letters requiring a personal reply should be accompanied by a stamped self-addressed envelope.

We cannot undertake to engage in discussions on the telephone.

## Component Supplies

Readers should note that we do not supply electronic components for building the projects featured in EVERYDAY ELECTRONICS, but these requirements can be met by our advertisers.

All reasonable precautions are taken to ensure that the advice and data given to readers are reliable. We cannot, however, guarantee it and we cannot accept legal responsibility for it. Prices quoted are those current as we go to press.

## Back Issues

Certain back issues of EVERYDAY ELECTRONICS are available worldwide price £1.00 inclusive of postage and packing per copy. Enquiries with remittance should be sent to Post Sales Department, IPC Magazines Ltd., Lavington House, 25 Lavington Street, London SE1 0PF. In the event of non-availability remittances will be returned.

## Binders

Binders to hold one volume (12 issues) are available from the above address for £4.60 inclusive of postage and packing worldwide. Please state which Volume.

## Subscriptions

Annual subscription for delivery direct to any address in the UK: £12.00. Overseas: £13.00. Cheques should be made payable to IPC Magazines Ltd., and sent to Room 2613, King's Reach Tower, Stamford Street, London SE1 9LS.

# STYLUS ORGAN

## WITH VIBRATO AND DECAY

BY R. A. PENFOLD

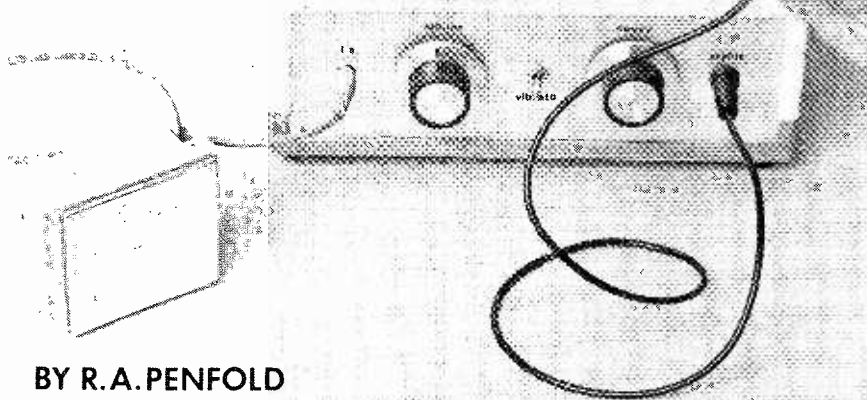

THE Stylus Organ is basically a conventional instrument which covers two octaves (including sharps or flats), one octave either side of middle C. It has a switchable vibrato oscillator, the use of which gives a more "rich" and pleasant sound. An unusual feature which can further enhance the sound, is a simple envelope generator circuit, and this gives a fast attack time with a decay time which can be varied from a fraction of a second to several seconds.

With a long decay time, the envelope shaper has little effect in normal use since changes from one note to the next occur before the volume of each note decays significantly. The unit then operates as an "ordinary" stylus organ. With a fairly short decay time, the character of the sound produced changes completely, and a sort of percussive sound is obtained.

The unit has a built-in amplifier but requires an external loudspeaker having an impedance of 8 ohms or more (although there is room to fit a small internal speaker). Construction is quite simple due to the use of a single printed circuit which forms the "keyboard" and accommodates all the components apart from the controls and the battery.

### SYSTEM DESCRIPTION

Fig. 1 shows the Stylus Organ in block diagram form. A voltage controlled oscillator (v.c.o.) is used to generate the basic sound, and the "keyboard" provides a series of 25 voltages which give the v.c.o. 25 different operating frequencies thus generating the required two

octaves of notes. A low frequency oscillator can be used to vary the v.c.o. control voltage very slightly so that notes are modulated either side of their normal frequency, and this gives the vibrato effect.

The output of the v.c.o. is fed to the amplifier output stage via a voltage controlled amplifier (v.c.a.), and under quiescent conditions the control voltage to the v.c.a. is zero so that the v.c.o. is cut off from the amplifier. However, the stylus is connected to a pulse generator circuit which produces a brief pulse each time a new note is played, and after shaping to produce a gradual decay over the desired period of time, this pulse is fed to the control input of v.c.a.

Thus the v.c.a. couples the tone signal straight through to the amplifier at the beginning of a new note, but it then

steadily reduces the amplitude of the signal during the course of each note as the control voltage diminishes. The effect of this envelope shaping can be seen by referring to the oscillograph (waveform shown on a scope) on page 558.

### THE CIRCUIT

The circuit diagram of the Stylus Organ is shown in Fig. 2. One section of IC2, an LM13600N dual transconductance op-amp, is used as the basis of the v.c.o. A transconductance amplifier is similar in many ways to an ordinary op-amp, but there are also substantial differences. The two main differences are that the differential input voltage to the device controls the output current, and *not* the output voltage, and there is a third input to the device. This input is called the "amplifier bias" input, and the bias current fed to this input controls the gain of the device.

In this circuit, the transconductance amplifier is used as a combination of a trigger circuit and a constant current generator. C5 is charged and discharged from the transconductance op-amp in IC2a at a rate which is determined by the bias current fed to pin 1 of the device via R10. This produces a roughly triangular waveform at the output of IC2a, and the operating frequency is controlled by the bias current applied to IC2a. R10 is used in series with the amplifier bias input so that the bias current is roughly proportional to the input voltage, and the required voltage rather than current controlled operation is obtained.

The output impedance of a transconductance amplifier is generally quite high, but the LM13600N incorporates a Darlington pair emitter follower buffer stage for each section of the device, and these can be used at the output of each amplifier to give a low output impedance. R12 is the discrete load resistor for the buffer stage for IC2a.

### KEYBOARD

The keyboard voltages are provided by 25 preset potentiometers (VR1 to VR25) which are connected across the supply rails. Each preset must be adjusted to give the correct note, but IC3 gives a well

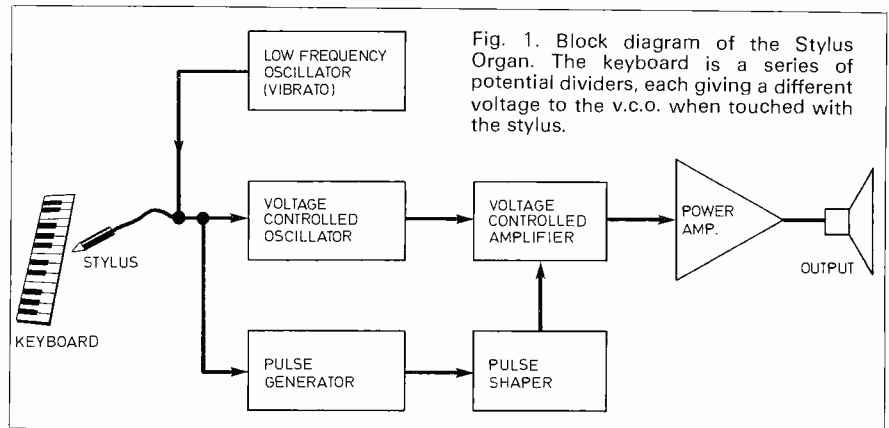

Fig. 1. Block diagram of the Stylus Organ. The keyboard is a series of potential dividers, each giving a different voltage to the v.c.o. when touched with the stylus.



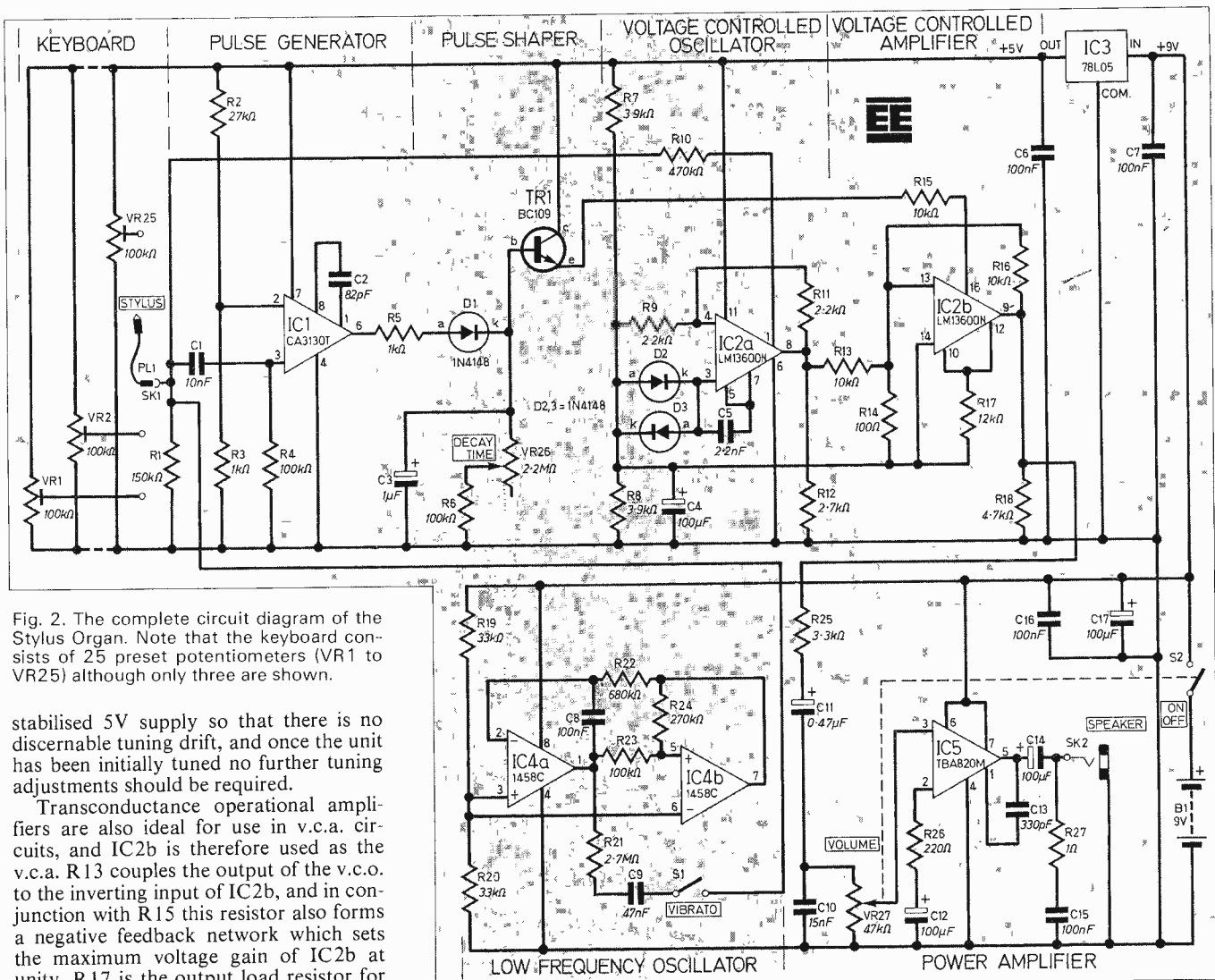

Fig. 2. The complete circuit diagram of the Stylus Organ. Note that the keyboard consists of 25 preset potentiometers (VR1 to VR25) although only three are shown.

stabilised 5V supply so that there is no discernable tuning drift, and once the unit has been initially tuned no further tuning adjustments should be required.

Transconductance operational amplifiers are also ideal for use in v.c.a. circuits, and IC2b is therefore used as the v.c.a. R13 couples the output of the v.c.o. to the inverting input of IC2b, and in conjunction with R15 this resistor also forms a negative feedback network which sets the maximum voltage gain of IC2b at unity. R17 is the output load resistor for the transconductance op-amp IC2b and R15 is used in series with the amplifier bias input to give voltage rather than current controlled operation, and it also limits the bias current to a safe level.

TR1 is used as an emitter follower buffer stage which boosts the input impedance at the control input of the v.c.a. from about 10 kilohms to several megohms. This is essential as the pulse shaper circuit has an output impedance which can be as high as a couple of megohms, and without TR1 excessive loading on the pulse shaper would occur.

IC1 is used as the pulse generator. The non-inverting input of IC1 is biased to the negative supply rail by R4, but the inverting input is given a small positive bias by R2 and R3. The output of IC1 is therefore low under quiescent conditions. When the stylus is connected to one of the keyboard presets this produces a small positive pulse which is coupled by C2 to the non-inverting input of IC1. This momentarily takes the non-inverting input to a higher potential than the inverting input so that the output briefly goes fully positive. A large but very brief pulse is therefore generated at the output of IC1 at the beginning of each note.

This pulse is fed by way of R5 and D1 to C3, and the latter is rapidly charged to almost the full supply voltage. C3 discharges more slowly since D1 prevents it from discharging through the low impedance of R5 and the output stage of IC1. Instead C3 discharges through the high resistance of VR26 and R6, and VR26 enables the decay time to be adjusted from about 0.2s at minimum resistance to around 5s at maximum resistance.

#### VIBRATO AND AMPLIFIER

The vibrato oscillator and output amplifier stages of the unit operate direct from the 9V battery supply and not via the 5V regulator. IC4 is a dual op-amp and this is used in the standard triangular/square-wave oscillator configuration. In this application, a triangular waveform is ideal as it gives a smooth variation in the operating frequency of the tone generator, and the square-wave output from IC4 is therefore ignored. R21 and C9 couple the triangular signal to the stylus, and S1 can be used to disconnect the oscillator when the vibrato effect is not required. If desired, the depth

of the vibrato can be changed by altering the value of R21. A lower value gives increased depth, a higher value gives a weaker vibrato effect.

The amplifier uses a TBA820M audio power amplifier i.c. (IC5), and this gives an output power of up to about 500mW r.m.s. into an 8 ohm impedance loudspeaker. A high impedance loudspeaker could be used, but the maximum output power available would be substantially reduced.

VR27 is the volume control and this also acts as the input bias resistor for IC5. R25 and C10 form a simple low-pass filter which attenuate the higher harmonics on the output from the v.c.o. and give the unit a more musical sound. R26 controls the voltage gain of IC5, and the specified value gives a modest but more than adequate gain of about 28dB (25 times). C13, C15 and R27 are needed to aid good stability. S2 is the on/off switch and this is ganged with volume control VR27.

The quiescent current consumption of the circuit is about 10mA, but the current drain can rise to several times this figure when the unit is used at high volume.

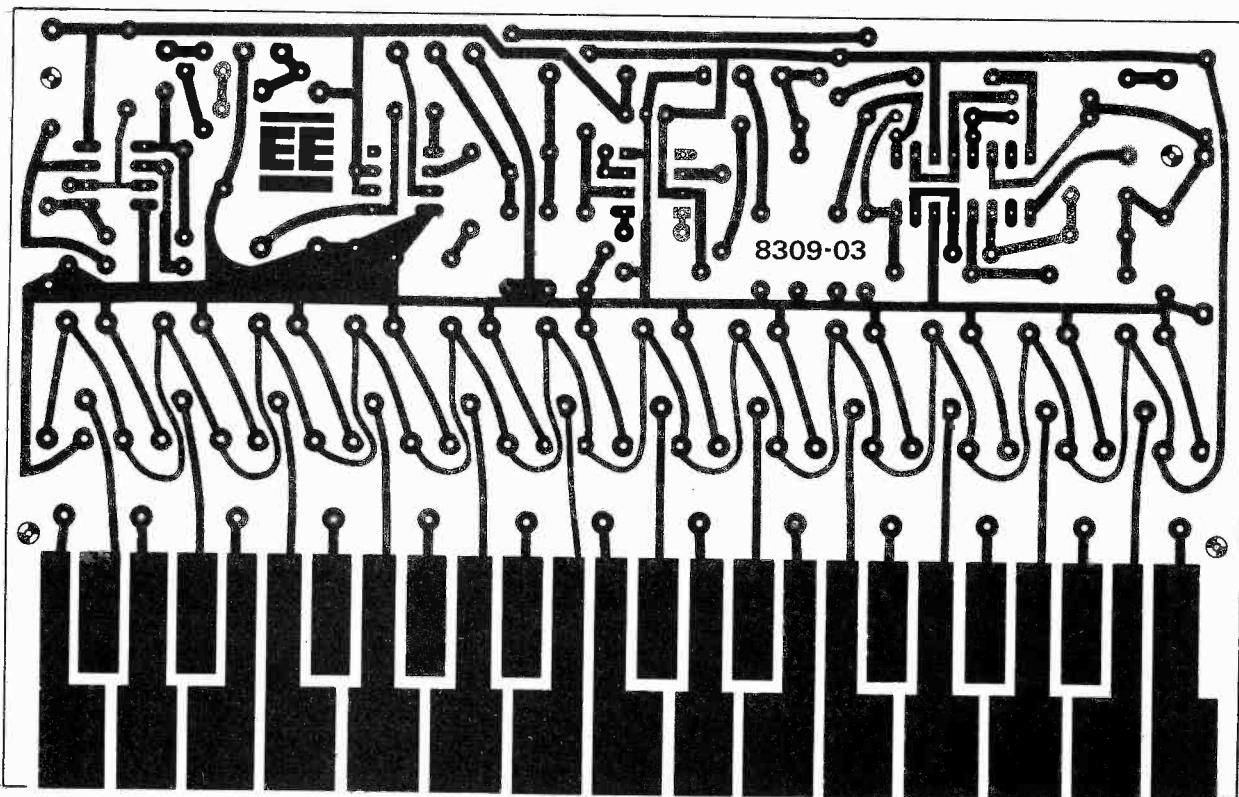

Fig. 3. The full-size artwork of the p.c.b. This board is available from the *EE PCB Service*, Order code 8309-03.

## CONSTRUCTION

### PRINTED CIRCUIT BOARD

Details of the printed circuit board are shown in Fig. 3, and this is constructed using the normal techniques. In order to give the completed unit a neat finish great care should be taken when applying the resist to the "keyboard" area of the board. Using rub-on transfers there should be no problems in producing good results, and reasonable results should be obtained using a resist pen if the outline of each "key" is drawn in with the aid of a ruler and then the outline is carefully filled in. In other respects the printed circuit board is straightforward. Alternatively, the board is available from the *EE PCB Service*, Order code 8309-03, see page 565.

Note that IC1 is a CMOS device and needs the normal handling precautions for MOS devices. If a CA3130E is used for IC2 this can be fitted into an 8-pin d.i.l. i.c. socket, and it should not be fitted into place until all the other components have been mounted on the board. The layout is shown in Fig. 4.

If CA3130T (TO-99 metal can) version is used, this could be soldered into place using a soldering iron having an earthed bit, and again it should be the last component to be fitted to the board and it should be handled as little as possible. Be careful to connect IC1 properly as it has the opposite orientation to IC4 and IC5, and it could be destroyed if the unit is switched on while it is connected incorrectly.

## COMPONENTS

Approx. cost  
Guidance only **£30.00**

### Resistors

R1	150k $\Omega$
R2	27k $\Omega$
R3,5	1k $\Omega$ (2 off)
R4,6,23	100k $\Omega$ (3 off)
R7,8	3.9k $\Omega$ (2 off)
R9,11	2.2k $\Omega$ (2 off)
R10	470k $\Omega$
R12	2.7k $\Omega$
R13,15,16	10k $\Omega$ (3 off)
R14	100 $\Omega$
R17	12k $\Omega$
R18	4.7k $\Omega$
R19,20	33k $\Omega$ (2 off)
R21	2.7M $\Omega$
R22	680k $\Omega$
R24	270k $\Omega$
R25	3.3k $\Omega$
R26	220 $\Omega$
R27	1 $\Omega$
All $\frac{1}{4}$ W carbon $\pm 5\%$	

### Capacitors

C1	10nF polycarbonate
C2	82pF miniature plate ceramic
C3	1 $\mu$ F 63V axial elect.
C4,14,17	100 $\mu$ F 10V axial elect. (3 off)
C5	2.2nF mylar
C6,7,8,15,16	100nF polyester (5 off)
C9	47nF polyester
C10	15nF polyester
C11	0.47 $\mu$ F 63V axial elect.
C12	100 $\mu$ F 10V radial elect.
C13	330pF ceramic

See  
**Shop  
Talk**  
page 565

### Semiconductors

D1,2,3	1N4148 silicon (3 off)
TR1	BC109 silicon <i>n</i> p <i>n</i>
IC1	CA3130T CMOS op-amp
IC2	LM13600N dual transconductance op-amp
IC3	78L05 5V, 100mA regulator
IC4	CA1458C dual op-amp
IC5	TBA820M audio power amplifier

### Miscellaneous

VR1-25	100k $\Omega$ 0.1W miniature preset horizontal mounting (25 off)
VR26	2.2M $\Omega$ lin. carbon potentiometer
VR27/S2	47k $\Omega$ log. carbon potentiometer with s.p.s.t. switch
S1	s.p.s.t. miniature toggle
SK1	4mm banana socket
SK2	3.5mm jack socket
PL1	4mm banana plug
B1	9V PP6 battery

**Printed circuit board:** single-sided size, 163 x 102mm, *EE PCB Service*, Order code 8309-03; Verobox size, 205 x 140 x 75mm (type 202-21035F); battery clip (same as PP3 type); control knob (2 off); test prod (for stylus); 7/0.2mm wire; mounting hardware; Veropins.

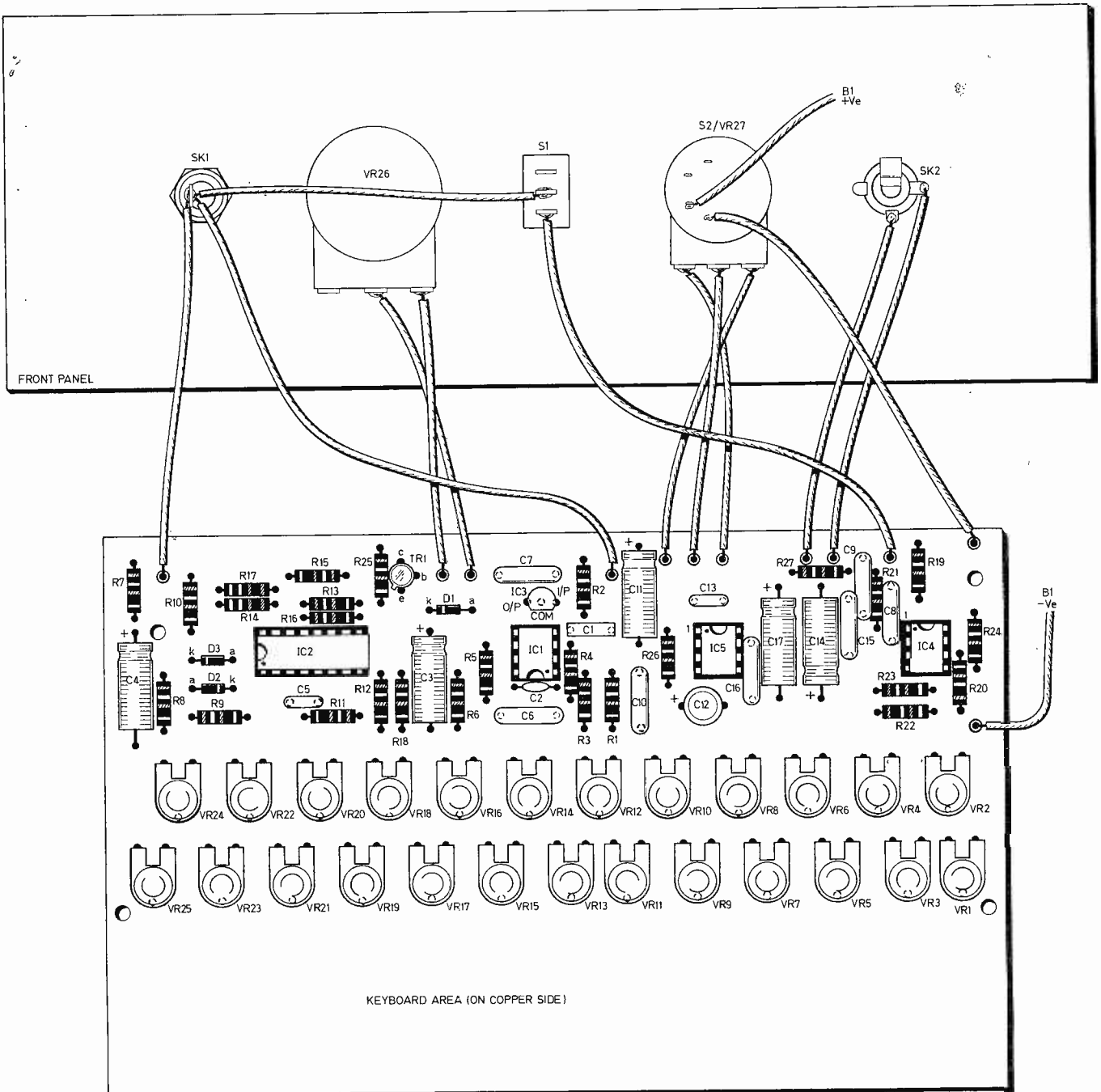
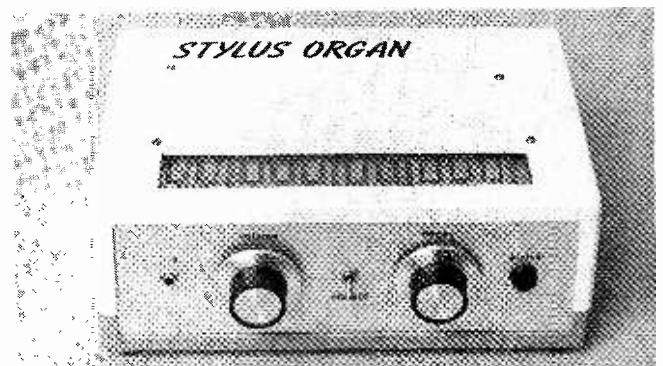
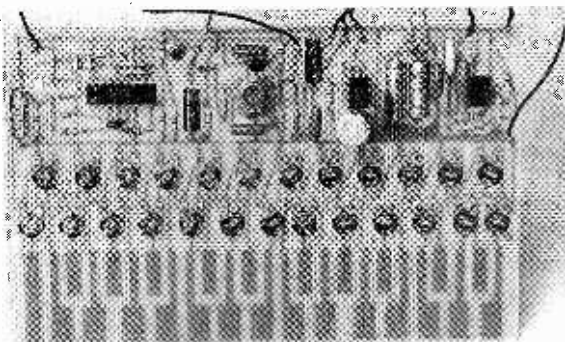
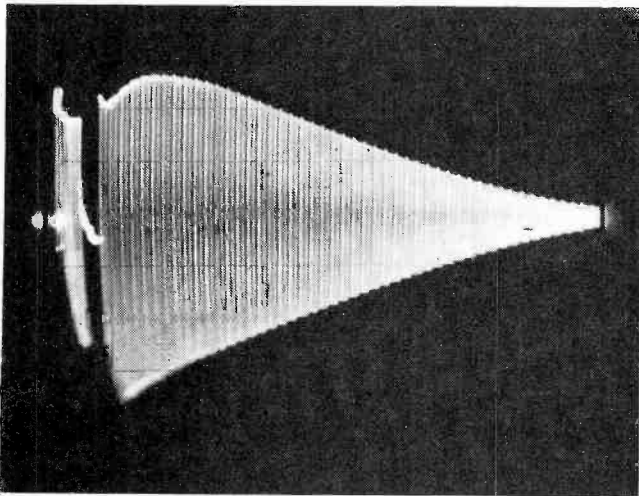
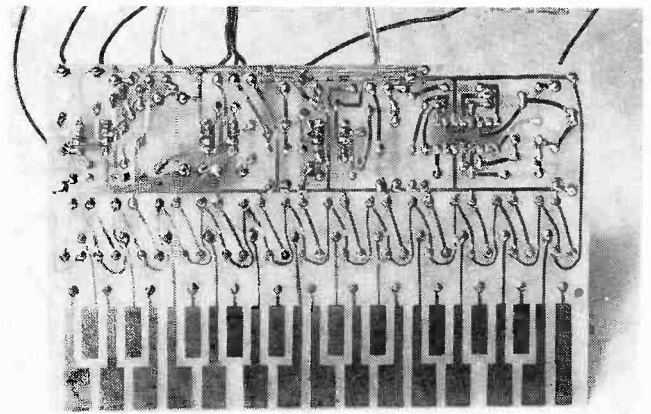

Fig. 4. The printed circuit board assembly and front panel wiring diagram. Note that the wires must be long enough to reach the front panel when the p.c.b. is mounted to the top of the case (see photograph over page). IC1 is shown as an 8-pin d.i.l. device but the TO-99 metal can version can also be used.





Oscillograph showing the rapid attack and slow decay provided by the envelope shaper. The section of the trace on the extreme left shows the rapid decay of the previous note when the stylus has been removed before the signal has decayed naturally.



The track-side of the p.c.b. showing the keyboard area. This is polished but not coated as good electrical contact is required with the probe tip.

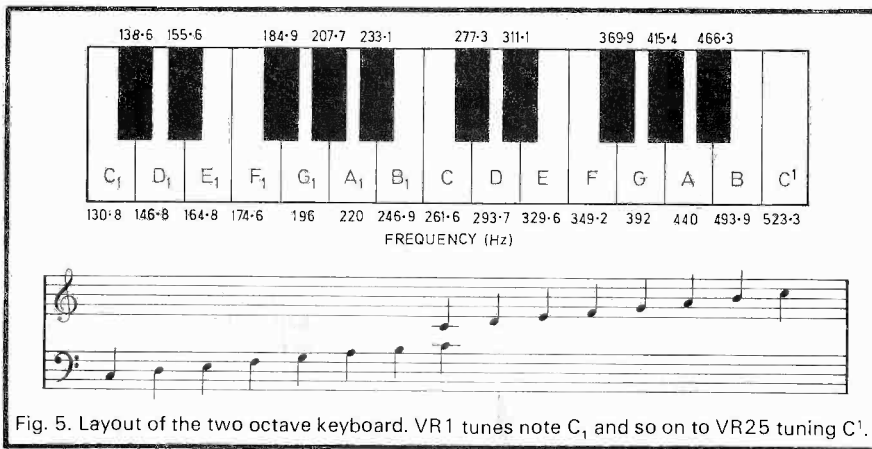

Fig. 5. Layout of the two octave keyboard. VR1 tunes note C<sub>1</sub> and so on to VR25 tuning C'.

### CASE

A Verocase of outside dimensions 205 × 140 × 75mm makes a convenient housing for this project. The three controls and the two sockets are mounted on

the front panel, and the printed circuit board is mounted on the underside of the top panel with its copper side facing upwards. A cut-out measuring 150 × 28mm is made in the top of the case and the

View inside the case top. Note that the p.c.b. is spaced slightly off the case with four additional nuts on the mounting screws.

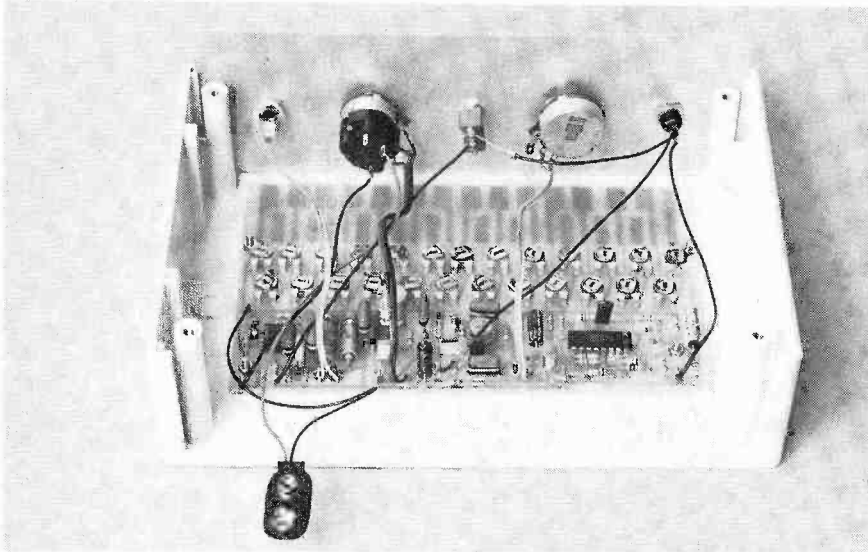

circuit board must be accurately mounted so that the "keyboard" is accessible through this cut-out. This cut-out can be made using a fret-saw, a coping saw, or a miniature file.

If an internal loudspeaker is required, there is sufficient space to fit a miniature type (up to 58mm in diameter) on the front panel in place of SK2, or a larger type on the base.

### ADJUSTMENT

The output of the Stylus Organ is coupled to any loudspeaker having an impedance of 8 ohms or more, and a fairly efficient loudspeaker (such as used with small music centres and similar equipment) is ideal. The output will also drive any normal type of earphone or headphone. A test prod is probably the best thing to use as the stylus, but it is also possible to use a small jack plug, a wander plug, or something of this nature.

The only adjustment required is to set the 25 preset potentiometers to give the appropriate notes. As mentioned earlier, the keyboard covers an octave either side of middle C, and is tuned using a piano or similar instrument to provide reference notes. The presets can be adjusted in any order. A layout of the keyboard is shown in Fig. 5 and the corresponding frequencies of the notes are given to aid tuning if using a frequency meter. When tuning the unit, adjust VR26 for maximum decay time (that is, fully clockwise) and switch out the vibrato effect.

After the instrument has been in use for some time it will probably be found that there is a noticeable change in frequency during each note, and this simply indicates that the battery voltage is becoming inadequate under maximum loading, and that a fresh battery is required. A PP6 9V battery is adequate, but if it is likely to receive a great deal of use and a low impedance loudspeaker is being used, it would probably be more economic to use a larger battery such as a PP9 type. There is plenty of space in the case to accommodate a larger battery. □



# A TO D CONVERTER FOR RM380Z COMPUTER



BY A.A. CHANERLEY B.Sc. M.Sc.

**T**HIS article describes the construction and use of a general purpose 8-channel, 8-bit wide Analogue-to-Digital Converter, tailored here for use with the Research Machines 380Z microcomputer. It will be used as the basis for the first six parts of our *Computer Aided Experiments* feature, see page 600.

Providing software is developed, it is possible to use this ADC with other computers fitted with a user port by connecting the appropriate cable connector.

## ANALOGUE-TO-DIGITAL CONVERSION

The computer, mainframe or micro, can only respond in any meaningful fashion to digital signals which are transmitted in either serial or parallel form. The 380Z has two ports for input and output signals. One is the printer port, and the other is the input/output user port; both are sockets at the back of the 380Z.

The signals they receive are in parallel form, eight input lines, each line capable of being in either a high state (logic 1) or low state (logic 0). The collective states of the eight lines, for example, 10101111 are called the binary word or byte. The maximum value of a byte is 255 in decimal corresponding to all eight lines high (11111111) or 0 in decimal corresponding to all eight lines low (00000000). Any intermediate combination of the "bit" pattern will correspond to a number between 0 and 255; for example, 00000011 is decimal 3.

In physical situations quantities such as temperature, pressure, light intensity and sound intensity vary in a continuous manner, altering gradually in response to some external event. Before a computer can measure any of the above quantities they must first be converted into an electrical signal.

This is possible by using a transducer. A microphone is a suitable transducer for converting the changing sound intensity from a person's speech into an electrical signal which changes exactly in step with the sound intensity.

This is only the first step, however. The computer will only respond in a meaningful fashion to digital signals and therefore it is necessary to convert the gradually changing (analogue) electrical signals from the transducer into a suitable digital input for the computer to work on; this is done electronically by the Analogue-to-Digital Converter (ADC) described here. The complete set-up is illustrated in Fig. 1.

## CIRCUIT DESCRIPTION

The complete circuit diagram of the Analogue-to-Digital Converter (ADC) is given in Fig. 2. As can be seen, the component count is very low, using only two integrated circuits and a few discrete devices.

The main component, IC2, is a 7581 which is an 8-bit 8-channel memory buffered data acquisition system in CMOS. It is capable of receiving eight separate analogue signals, each signal having a maximum value of +10V per channel when used in the unipolar mode, and -5V to +5V when in bipolar mode.

The design described here is unipolar mode in order to simplify construction and keep cost to a minimum.

The 7581 i.c. has a multiplexer, digital-to-analogue converter (DAC), registers, a comparator and control logic all on the one chip. It stores each analogue channel in succession and stores the latest result in eight 8-bit RAM locations which are on-board. Each channel is then selected by software.

Each channel takes 80 clock cycles for a complete conversion, or 640 cycles for all eight channels. With a 1MHz clock, that is 80µsec per channel and 640µsec for all eight channels.

There is also a status pin (pin 12)

*A. A. Chanerley is Head of Physics at La Retraite High School for Girls, London.*

which goes low when a channel conversion is complete thereby giving interrupt facility for real-time applications. This function however is not included in this design and those interested in such applications should consult the technical data sheet for the 7581. The block diagram of the 7581 internal circuitry is shown in Fig. 3.

### POWER SUPPLY

Requirements for this chip are +5V (supply) and -10V reference, and a 1MHz clock. The latter is provided by the two gates IC1a and IC1b with components R1, R2 and C1. IC1c acts as a buffer for this arrangement.

All power requirements are provided by the 380Z, +5V direct and -10V derived from the -12V available on the user port by means of Zener diode D1 with series limit resistor R3. When used with other computers these supplies may not be available and will need to be derived externally. Sufficient space exists in the specified case for such circuitry.

The 8-bit digital output is connected to the 380Z user port socket data-in lines DI0 to DI7 via a 25-pin D-type connector PL1 where +5V, -12V and 0V are also picked up. The user port also has

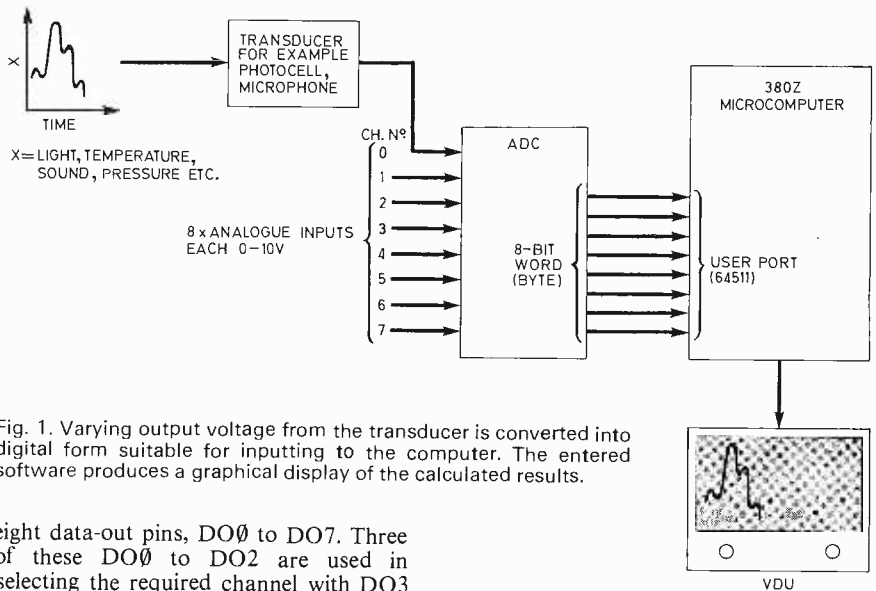
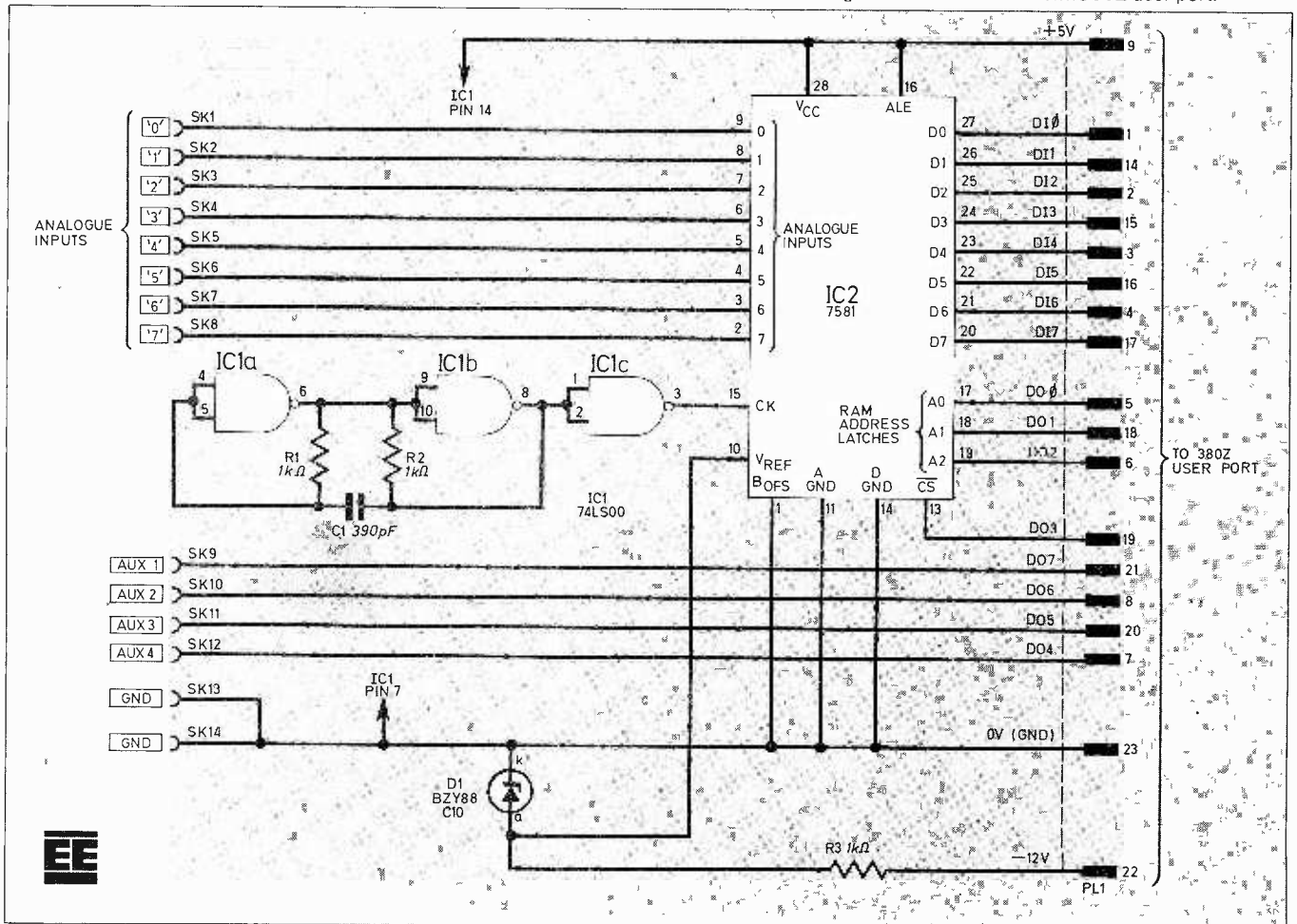

Fig. 1. Varying output voltage from the transducer is converted into digital form suitable for inputting to the computer. The entered software produces a graphical display of the calculated results.

eight data-out pins, DO0 to DO7. Three of these DO0 to DO2 are used in selecting the required channel with DO3 providing the necessary decoded CS. The other four data-out lines are available to the user at SK9 to SK12 so that the computer may be used to control other equipment such as motors that may be required in A-to-D experiments for such purposes as transducer position and movement.

The digital outputs may be read by the 380Z through a PEEK(64511) statement, with the data-out signals controlling A0, A1 and A2 which select the appropriate RAM location in the 7581 holding the experimental data, through a

Fig. 2. Complete circuit diagram of the 8-channel Analogue-to-Digital Converter configured for use with the RM380Z user port.



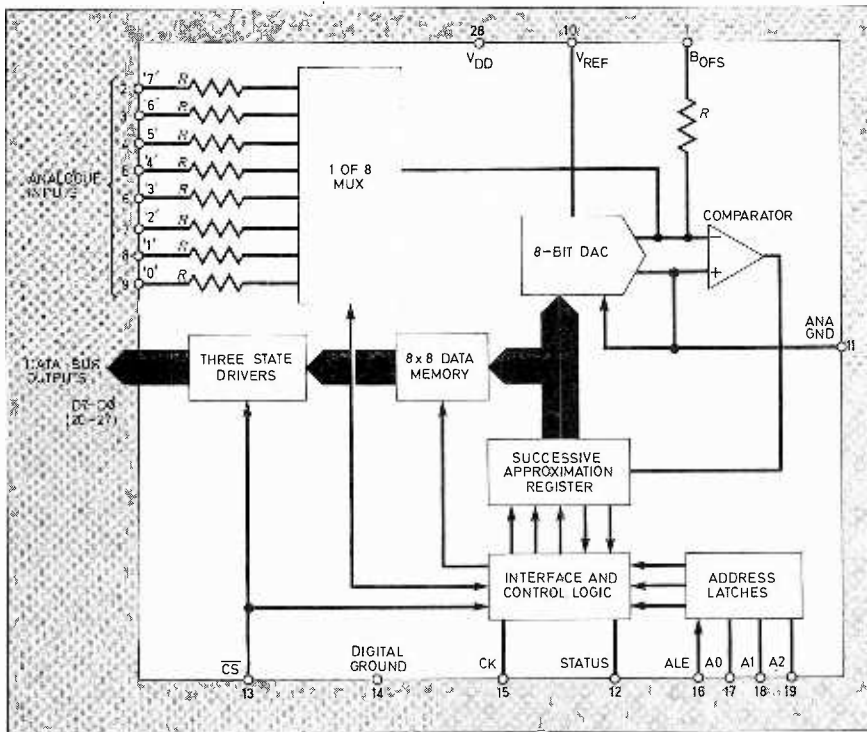

Fig. 3. Internal block diagram of the 7581 A-to-D converter i.c.

Table 2. Data-in pins on the user port

PL1 Pin No.	Data Line No.	Decimal Value
1	D0	1
14	D1	2
2	D2	4
15	D3	8
3	D4	16
16	D5	32
4	D6	64
17	D7	128

### DATA-IN

Table 2 shows the data-in pins which connect to the digital outputs of the 7581 on the circuit diagram, and constitutes the 8-bit word (byte) which corresponds to the converted analogue data. All pins high gives 255 (1 + 2 + 4 + 8 + 16 + 32 + 64 + 128); this is equivalent to the maximum analogue input of 10 volts. All pins low is of course 0 volts. Any intermediate bit pattern corresponds to intermediate analogue voltage between 0V and 10V.

These pins are read by the PEEK (64511) statement, which follows the appropriate POKE64511,XX command.

POKE64511,XX statement where XX takes on values from 0 to 7 depending on the analogue channel selected.

### TEST ROUTINE

```

10 POKE64511,8:REM clear data lines: GRAPH 1: GRAPH 0
20 INPUT X:REM select channel number
30 POKE64511,X:REM initialize selected channel
40 Y=PEEK(64511):REM read value of digital output from 7581
50 PLOT 40,50,STR$(Y)+" ":REM print data at grid ref 40,50
60 GOTO 30:REM go back for next value of data
  
```

### DATA-OUT

Table 1 shows the bit pattern associated with the data-out pins. Each pin is controlled by the POKE statements shown. For example, pins 5, 18, 6 are connected to A0, A1, A2 of the 7581 chip and these address the RAM locations, corresponding to the analogue inputs, inside the chip.

So that POKE64511,00 selects analogue channel 0 with pins 5, 18, 6 all low. Then the statement POKE64511,01 selects the analogue channel 01, with pin 5 high, and pins 18 and 6 low. POKE64511,03 statement selects channel 03, with pins 5 and 18 high and pin 6 low, that is, 011 in binary which is 3 in decimal, and so on.

The logic levels for these pins, 6, 18 and 5 for all eight channels are: 000, 001, 010, 011, 100, 101, 110 and 111 corresponding to channels 00, 01, 02, 03, 04, 05, 06 and 07.

Pins 21, 8, 20 and 21 correspond to the auxiliary outputs on the unit marked AUX1 to AUX4. Using the appropriate POKE statement these pins can be made high (or low) to activate external circuitry.

Table 1. Data-out pins on user port

PL1 Pin No.	Data Line No.	Bit Pattern	Basic Statement	To
5	D0	00000001	POKE64511,2 <sup>0</sup>	A0
18	D1	00000010	POKE64511,2 <sup>1</sup>	A1
6	D2	00000100	POKE64511,2 <sup>2</sup>	A2
19	D3	00001000	POKE64511,2 <sup>3</sup>	CS
7	D4	00010000	POKE64511,2 <sup>4</sup>	AUX4
20	D5	00100000	POKE64511,2 <sup>5</sup>	AUX3
8	D6	01000000	POKE64511,2 <sup>6</sup>	AUX2
21	D7	10000000	POKE64511,2 <sup>7</sup>	AUX1



# A TO D CONVERTER

## RM380Z COMPUTER

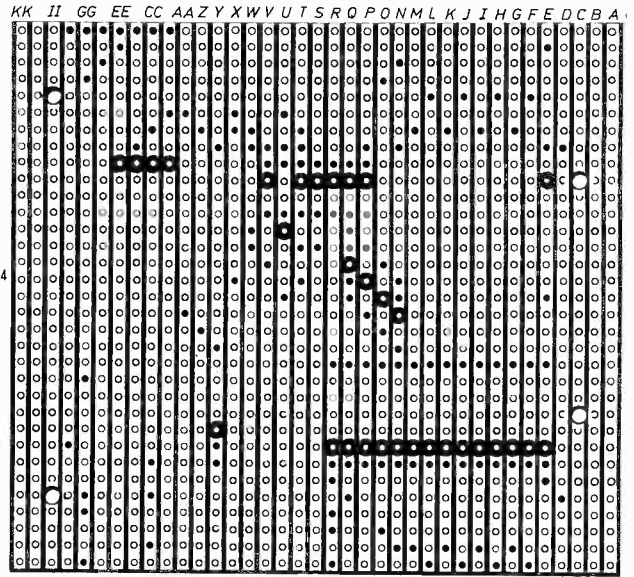
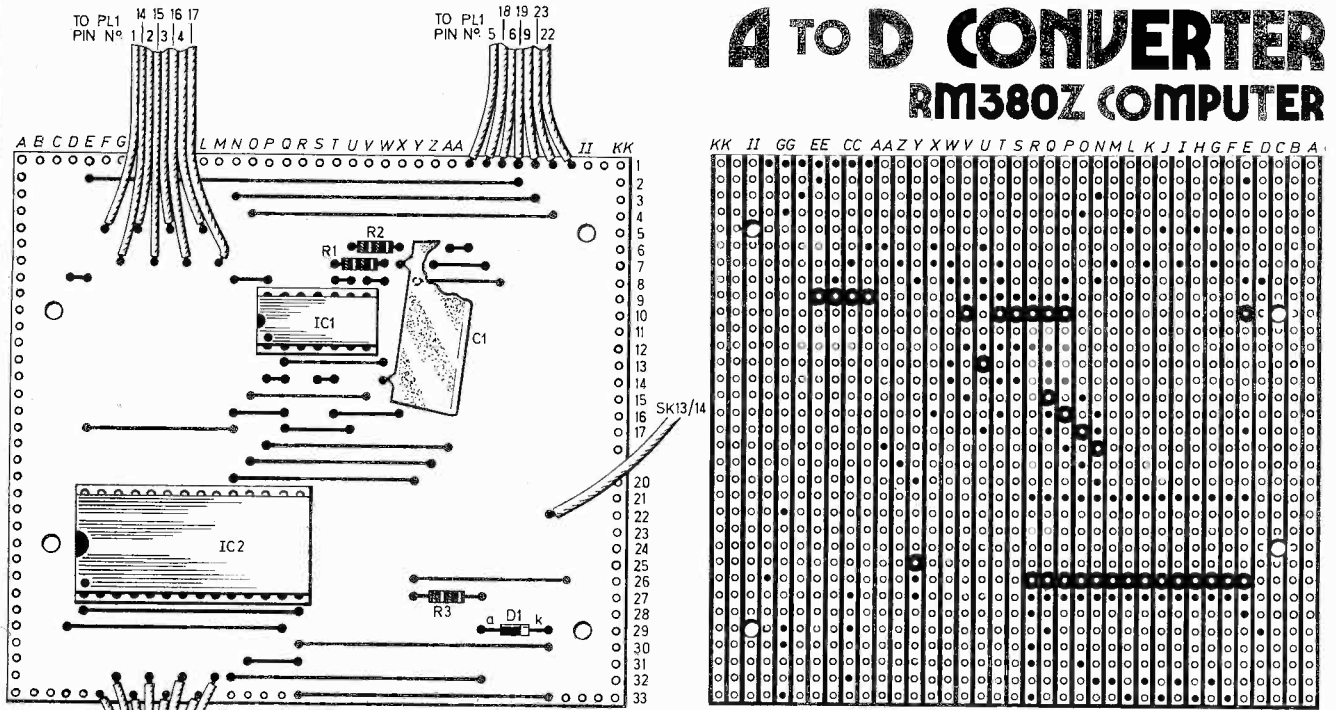

Fig. 4. Layout of the components on the topside of the stripboard with interconnection details to sockets and PL1. Above shows breaks to be made in the copper tracks on the board underside.

### COMPONENTS

#### Resistors

- R1 1k $\Omega$
- R2 1k $\Omega$
- R3 1k $\Omega$
- All  $\frac{1}{4}$ W carbon  $\pm 5\%$

See  
**Shop  
Talk**  
page 565

#### Capacitor

- C1 390pF silvered mica

#### Semiconductors

- IC1 74LS00 TTL low power Shottky quad 2-input NAND
- IC2 7581 8-channel 8-bit analogue-to-digital converter i.c.
- D1 BZY88C10 10V 400mW Zener diode

#### Miscellaneous

- SK1-14 4mm insulated panel mounting sockets (8 black, 4 red, 2 green)
- PL1 25-way, D-type vertical sub-miniature plug with cover

Stripboard: 0.1 inch matrix, size 37 strips x 33 holes; 20-way colour-coded ribbon cable (not i.d.c. type) length as required; Vero plastic box 202-21031G or similar, size 188 x 110 x 60mm; self-adhesive rubber feet (4 off); snap-fixing plastic stand-off pillars 6mm high (4 off); d.i.l. sockets: 28-pin, 14-pin (1 off each); wire for on-board links.

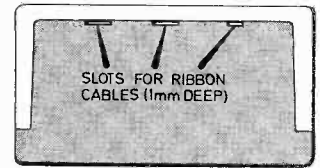
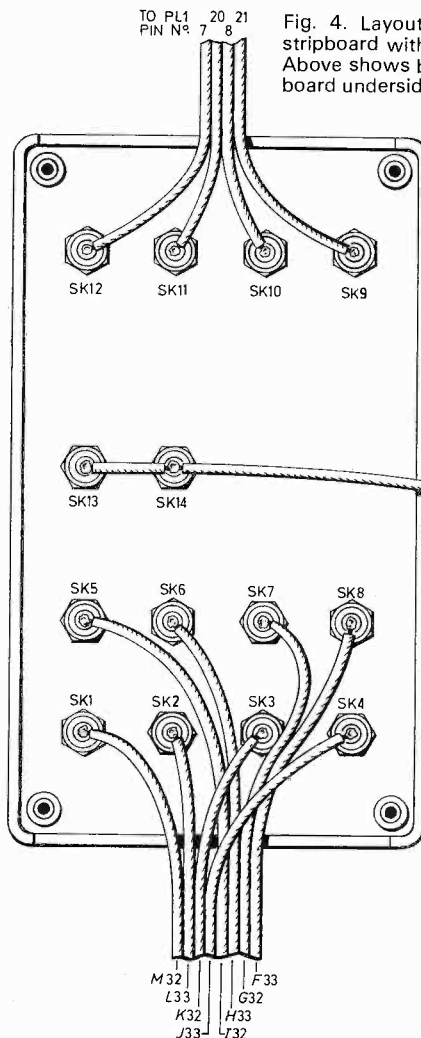

END VIEW OF BOX

Fig. 5. Position of the top panel mounted sockets and interwiring details to the board and PL1. Top right shows position of the recesses to be made in the case to allow the exit of the three ribbon cables.

**COMPONENTS**  
approximate  
cost **£27**



# CONSTRUCTION

## CONSTRUCTION

The Analogue-to-Digital Converter is constructed on 0.1 inch pitch stripboard, size 37 strips × 33 holes. This board size differs in strip count from that seen in the photographs as we have increased its size to provide a different board fixing method than that used in the prototype. This larger board requires a wider case than that seen and the next size up in the same style is specified in the components list.

The analogue inputs are made in 4mm panel mounting sockets. The four sockets labelled AUX are not essential. They provide access to user port signal lines DO4 to DO7 and were included by the author for work he has in mind for the future. There is space in the case for fitting further sockets or circuitry if the user so wishes, perhaps from another outlet from the 380Z that could be useful in A-to-D experiments.

The layout of the components on the topside of the stripboard is shown in Fig. 4. A number of breaks in the copper strips on the underside need to be made. Use a spot-face cutter or a small (3mm) diameter twist drill to make these breaks. Drill the four board fixing holes as shown to suit the fixing hardware. We suggest 6mm high snap-fixing plastic stand-off pillars which require a 3.8mm diameter hole in the board with a 5mm diameter hole drilled in the case. Use the drilled board as a template to drill pilot holes in the case base and then enlarge to 5mm. In this way, the two sets of fixing holes are

correctly aligned and so exert minimal strain on the board.

Continue by mounting the i.c. sockets followed by the numerous link wires. You should use plastic covered single core wire or tinned copper wire sleeved at positions where the conductors run close. Next solder in the resistors, capacitor and Zener diode paying attention to orientation of this device.

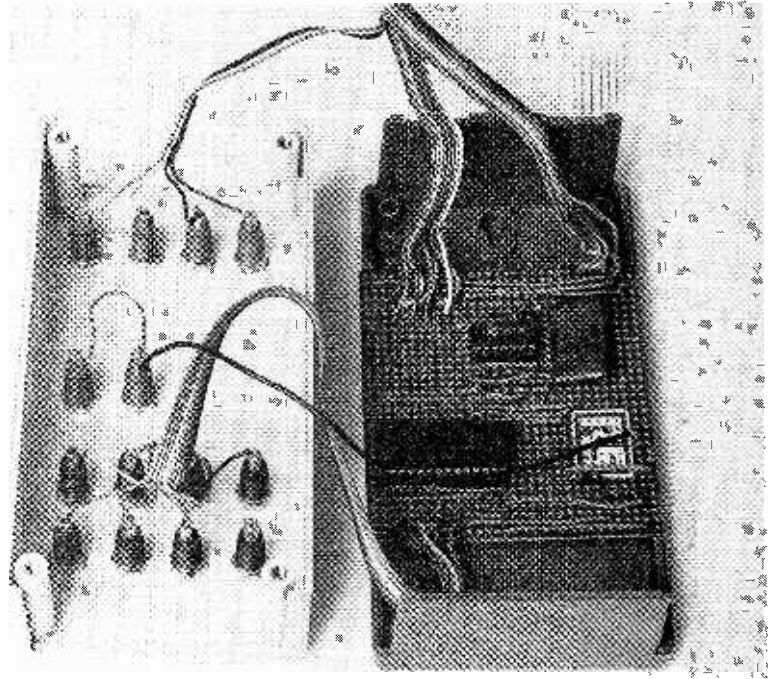

The completed prototype with separated case sections.

Table 3. 380Z user port pin assignment details

Pin No.	Function	Pin No.	Function	Pin No.	Function
1	DI0	11	*	21	DO7
2	DI2	12	*	22	-12V
3	DI4	13	*	23	0V
4	DI6	14	DI1	24	*
5	DO0	15	DI3	25	*
6	DO2	16	DI5		
7	DO4	17	DI7		
8	DO6	18	DO1		
9	+5V	19	DO3		
10	+12V	20	DO5		
					* Not specified

Fig. 6. View of the connectors on the 380Z microcomputer rear panel (not to scale) clearly showing the user port socket with pin numbers.

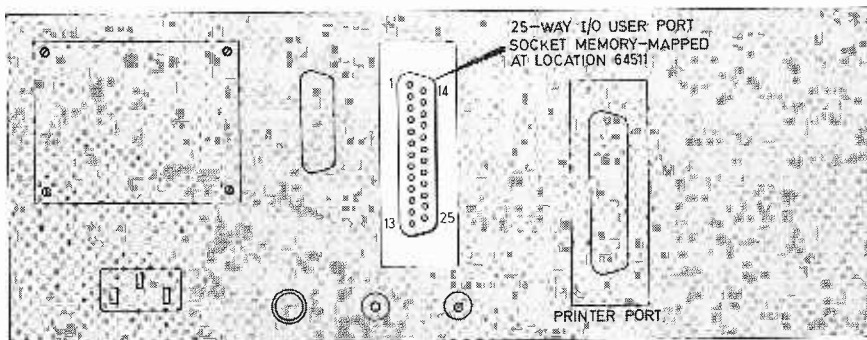

## CABLES

The ribbon cable connecting the board to the sockets and PL1 was soldered directly to the board tracks. Another idea is to use Veropins for this connection which will then allow the board to be positioned in the case before wiring up. Fit the Veropins now if you choose this method. Thoroughly check your construction before proceeding.

Prepare the lid of the case to accept the 4mm sockets SK1-SK14, see Fig. 5. When fitted, wire up SK1-SK8 to the board. Ribbon cable (8-way) was used for this in the prototype. Connect GND sockets to the board using stranded plastic covered wire. The easiest way to run the ribbon cables out of the case is to file three small recesses in one of the case end edges (lower section): two at 10 × 2mm and one at 5 × 2mm. When the lid is finally assembled, the lid will grip the cable firmly. It would be a good idea to fit self-adhesive ribbon cable grippers about 10mm below the recesses to align the cables with their respective outlets.

Fit the i.c.s in their sockets paying special attention to orientation and then push the board onto the plastic stand-off pillars which you have already positioned in the case.

There are two ribbon cable groups that connect the board to PL1. Solder sufficient lengths of 8-way and 7-way cable to the board and a similar length of 4-way cable from SK9-SK12 to reach the user port via PL1. Feed the cables out through their recesses after being fitted in their grippers.

Identify each of the wires and, with reference to Fig. 6 and Table 3, connect them to PL1 to complete the assembly. Screw on the lid and the unit is ready for testing.

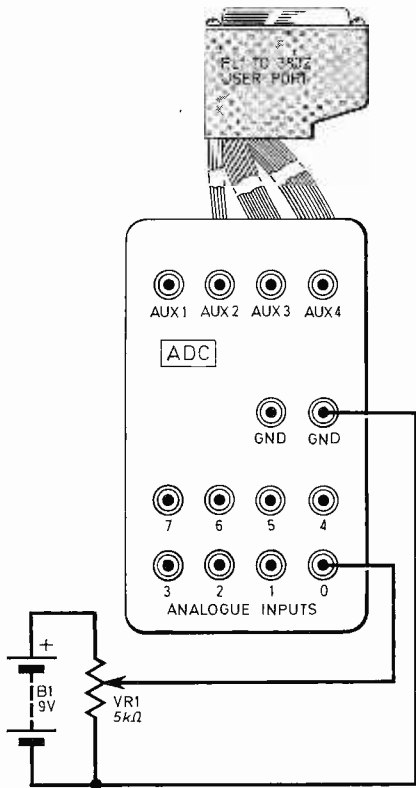

Fig. 7. Simple test circuit for checking out the ADC unit. Use the "Test Routine" software given earlier.

## TEST CIRCUIT

A simple test circuit which consists of a 9V battery whose voltage is divided by a 5 kilohm potentiometer is shown in Fig. 7. By twirling the wiper and thus altering the voltage at the wiper, the value of the data byte printed at grid reference 40,50 on the v.d.u. will be seen to vary between 0 and 230, corresponding to 0V and a maximum of 9V in this case; 255 is for a maximum of 10V, so the scale factor is easily calculated ( $=9/230$ ).

The equation giving the relationship between the input voltage and the binary output is:

$$V = kN$$

where  $V$  = analogue input voltage  
 $N$  = 8-bit binary output  
 $k$  = a constant

In this particular case

$$N = 255$$

when  $V = 10V$

and therefore the value of

$$k = 10/255$$

This, of course, can be written into the programme, so that the software will plot the actual value of the voltage in line 50 of the Test Routine rather than the decimal equivalent of the data byte.

If the above test was successfully carried out, you now have a useful instrument for use with a 380Z microcomputer in the science laboratory for many experiments. With suitable software, experimen-

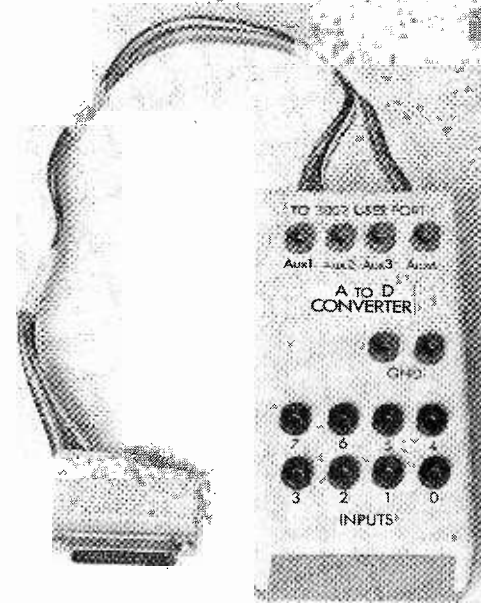

tal results may be collected, stored, plotted and analysed. For ideas of its use see *Computer Aided Experiments*, page 600, a new series starting this month. □

# COUNTER INTELLIGENCE

BY PAUL YOUNG

## Ion Tonic

I would like to begin by thanking the readers who were kind enough to write to me on the subject of Ionisers (see May '83 issue). Their letters were all most enlightening, but the letter I found the most useful, came from Mr. C. Hyde of Beds.

With his letter he kindly enclosed the circuit of a simple apparatus which would give an indication as to whether the negative ions were flowing, see Fig. 1. This could be mounted on a small piece of wood.

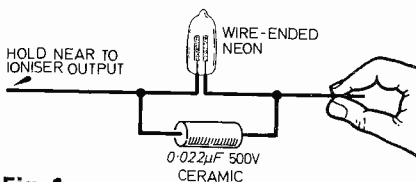

Fig. 1

The bare wire at one end is held between the thumb and index finger, and the bare wire at the other end is brought near the source of the negative ion emission. The neon lamp will flash intermittently, and the closer it gets to the source, the faster it flashes.

It could be constructed for a few pence and is particularly useful for gauging when the needles from which the ions flow need cleaning. I can confirm that the needles do become corroded in time and then the flow slows down. The best way to rectify this is to polish them with some fine emery cloth or sandpaper.

One reader told me that the Cockcroft Walton circuit tended to produce too much Ozone and therefore some of the commercial machines use a different circuit. I must confess I have not noticed it myself, although it always seems to be present when there is a high voltage discharge. It is a rather penetrating pungent smell which tends to irritate the membranes of the nose and throat.

Another reader successfully disposes of the "Placebo" argument by pointing out that negative ions have been proved beneficial to animals. The thought had never struck me before, that it is useless giving a placebo to an animal.

Lastly a reader from Jersey pleads for a simple constructional article for an Ioniser. Well, Mr. Yates, I have some good news for you. I have it on the highest authority that you can expect to see such an article in EVERYDAY ELECTRONICS in the next two to three months.

## Wide Interest

The other day, I was idly contemplating the difference between two contrasting professions, the Antique Dealer and the Electronic Engineer. Now before everyone starts muttering, "What on earth does old Paul Young know about Antiques?" I will have you know that my aunt had an Antique shop in North Road, Highgate Village, for many years. She also had a stall in the Caledonian Market every Friday. Now please keep this to yourselves, I wouldn't want it broadcast, but I sometimes used to look after the stall in the hope of extra cash.

All this is by the way, but to me the interesting thing is this. The field of Antiques is fairly limited. Even so, in the case of my own relations, and no doubt this was repeated throughout the trade, they decided there was so large an area to be covered that the only satisfactory way to achieve it was by specialisation. Consequently, my aunt was an expert on China, my uncle Pictures, my cousin Furniture.

By contrast, the field of Electronics is expanding in all directions at the speed of light. I, and even colleagues who are considerably younger are almost overwhelmed by the speed of progress and the magnitude of the task of keeping abreast of modern practice.

I think all of us, have long realised, that the only hope is specialisation in a very narrow sector, and this, dare I say it, could become extremely dull and boring. I am glad to note that EVERYDAY ELECTRONICS is not proceeding along these lines, but keeping its interests wide and varied.

Long may this policy continue. All the same, there are times when I wish I had taken up Antiques.

# SHOP TALK



BY DAVE BARRINGTON

## Comptalk

While industry's attention has been firmly focused on "Office of the Future" systems, **Maplin Electronics** have just introduced, what they call, "Shopping of the Future" for its customers. It is now possible for orders to be placed directly with their computer by means of a customer's home or personal computer.

All the customer needs, apart from his home computer, is a modem kit and interface unit. A modem kit, £39.95, and a ZX81 interface, £19.95, are available now. Before long, it is hoped, that most popular microcomputer systems will be able to join the electronic shopping club.

Apart from the "interrogation" equipment, the prospective customer will need to be equipped with a Maplin catalogue product code number, a credit card number plus a conveniently sited telephone.

Having dialled directly into the Maplin computer system, the user will be able to access the stock file and place his order. The user's screen will display stock availability, the current price and total amount to be charged to the credit card account.

For more details of the Maplin Computer Shopping Service write to: **Maplin Electronic Supplies Ltd., Dept EE, PO Box 3, Rayleigh, Essex SS6 8LR.**

## Constructor's Aid

Sometimes we hear from readers who, having seen an article in our pages, rush out purchase the components and then find, through one reason or another (usually lack of time), that they are unable to complete the project. Then there is

### EE PRINTED CIRCUIT BOARD SERVICE

Printed circuit boards for certain EE constructional projects are now available from the EE PCB Service, see list right. These are fabricated in glass-fibre, and are fully drilled and roller tinned. All prices include VAT and postage and packing. Remittances should be sent to: EE PCB Service, Everyday Electronics Editorial Offices, King's Reach Tower, Stamford Street, London SE1 9LS. Cheques should be crossed and made payable to IPC Magazines Ltd.

**Readers are advised to check with prices appearing in current issue before ordering.**

the reader who has built his project but has difficulty in getting it to work.

When we receive letters from readers in this vein, we have to write back regretting that we are unable to accept and "troubleshoot" individuals models. We can only advise, from the information contained in the letter and about circuits published in EE, as best we can but this can only be in general terms as we cannot take into account the standard of construction.

Most faults are usually traced back to bad soldering, missing links or neglecting to make all the necessary cuts in copper strips. Always check the wiring against the circuit—we are not immune against errors ourselves.

We have just heard that **Webb Logic Systems** have spare capacity in their workshops and are prepared to undertake the task of sorting out readers' problems with any published design. They claim they will build, test and/or repair any partially or completed projects.

The average cost for the complete assembly of most projects is in the region of £10 to £20. But they do reserve the right to make exceptions to the costing in cases of (in their assessment), complex and poorly submitted models.

We have not seen the service in action, but feel sure that readers will welcome this facility. For more information readers should write to: **Webb Logic Systems Ltd., Dept EE, Gainsborough House, 15 High Street, Harpenden, Herts AL5 2RT.**

## Distress Beacon

The instrument case for the pocket version of the *Distress Beacon* is available direct from Lascar Electronics Ltd., Dept EE, Module House, Whiteparish, Salisbury, Wilts.

The NiCad PP3 equivalent batteries were obtained from Ambit. Suitable equivalent are also stocked by various advertisers.

Other components likely to prove difficult to locate are the mercury switch, Xenon tube, diac and triac. The Xenon tube and transformer, diac and triac are available from Maplin. Several advertisers stock mercury switches and it should be possible to adapt these for this design.

## A/D Converter

The D-type connector for the *A/D Converter* is available from Bi-Pak, Maplin, Electrovalue, Cricklewood and Rapid Electronics.

The 8-channel 8-bit analogue-to-digital i.c., type 7581, is stocked by RS Components, Order code 303-545. RS Components will *not* supply to the general public but must be ordered through a local recognised stockist.

## Stylus Organ

The semiconductor devices appear to be the only item that could cause any purchasing problems for the *Stylus Organ*.

The dual transconductance amp. type LM13600N, seems to be only listed by Cricklewood, Maplin and Rapid Electronics. However, all components for this project are stocked by Maplin.

## Microcomputer Interfacing Techniques

As far as components for this month's constructional projects, for the *Microcomputer Interfacing Techniques* series, go we cannot foresee any problems for the *Signal Conditioning Amplifier*. However, the ZN449 only seems to be available from JEE Distribution Ltd., Dept EE, 43 Stathville Road, London, SW18 4QX.

## Computer Aided Experiments

The photodiode, with integral amplifier, used in the *Computer Aided Experiments* was obtained from RS Components and carries the stock number, 308-067. This device is only available from a recognised RS dealer.

We do not expect any component buying problems for the *Traffic Light Simulator* and the *Voltage Dualiser* projects.

PROJECT TITLE	Order Code	Cost
Eprom Programmer, TRS-80 (June 83)	8306-01	£9.31
Eprom Programmer, Genie (June 83)	8306-02	£9.31
Eprom Programmer, TRS-80 & Genie (June 83)	8306-03	£1.98
User Port Input/Output <i>M.I.T. Part 1</i> (July 83)	8307-01	£4.82
User Port Control <i>M.I.T. Part 1</i> (July 83)	8307-02	£5.17
Storage Scope Interface, BBC Micro (Aug 83)	8308-01	£3.20
Car Intruder Alarm (Aug 83)	8308-02	£5.15
Electronic Die (Aug 83)	8308-03	£4.56
High Power Interface <i>M.I.T. Part 2</i> (Aug 83)	8308-04	£5.08
Pedestrian Crossing Simulation <i>M.I.T. Part 2</i> (Aug 83)	8308-05	£3.56
High Speed A-to-D Converter <i>M.I.T. Part 3</i> (Sept 83)	8309-01	£4.53
Signal Conditioning Amplifier <i>M.I.T. Part 3</i> (Sept 83)	8309-02	£4.48
Stylus Organ (Sept 83)	8309-03	£6.84
Distress Beacon (Sept 83)	*8309-04	£5.36
Distress Beacon Pocket Version (Sept 83)	8309-05	£3.98

\*Set of four boards.

M.I.T.—Microcomputer Interfacing Techniques, 12-Part Series.

# DISTRESS BEACON

FOR MARINE USE  
PLUS A POCKET VERSION  
FOR FELL WALKERS  
& MOUNTAINEERS

BY P. E. HOPKINS

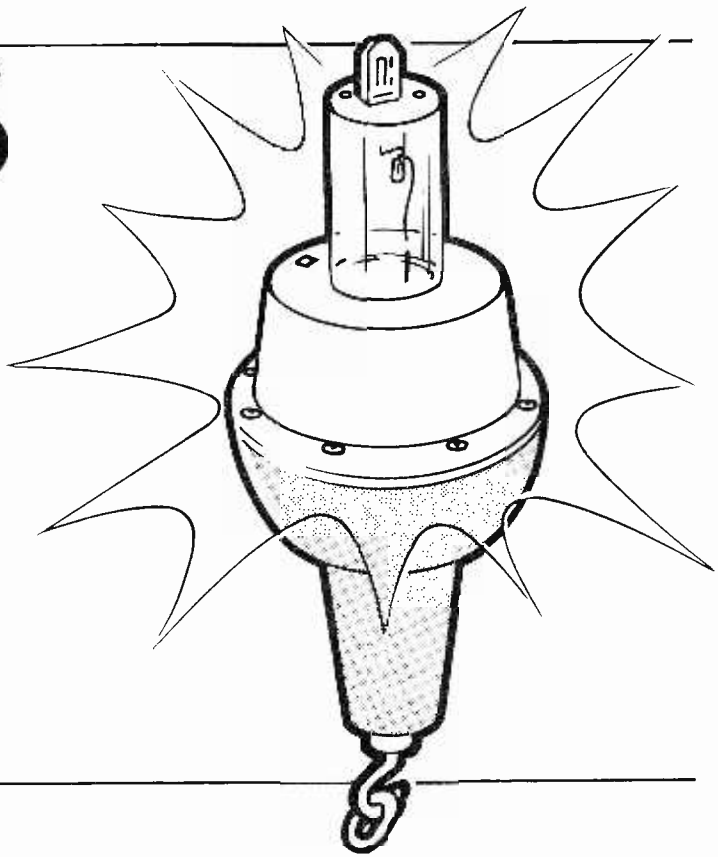

**M**AN OVERBOARD at night is a distressing experience both for crew as well as victim. Time is the essence, and quick positive action essential in order to avoid loss of life.

With the Distress Beacon mounted in an accessible position, and easily located by the small flashing light on the lamp housing, all that needs to be done is to toss it overboard. Immediately on hitting the water, the beacon is activated, emitting a powerful flash of light and providing a reference point both for swimmer and helmsman. A spiral rescue pattern working inwards to the beacon should soon effect a speedy rescue.

The beacon is totally sealed to prevent water entering, and is powered by nickel-cadmium cells, inductively charged from an external circuit, thus eliminating leakage or corrosion problems associated with connectors.

Constructors may prefer to use a casing of their own design, however, details are included of the moulding techniques as used in the original, and those that have had no previous experience in glass-fibre moulding may be delighted to discover how easy it really is using readily available moulds from off any supermarket shelf.

## POCKET BEACON

For fell walkers, climbers and hikers, a pocket version of the Distress Beacon is also described. It is designed to fit into a calculator-type case and can be attached to an anorak or rucksack.

So if the user should become lost in darkness or mist, or fall injured and be unable to return, the Beacon will attract the attention of the rescue party.

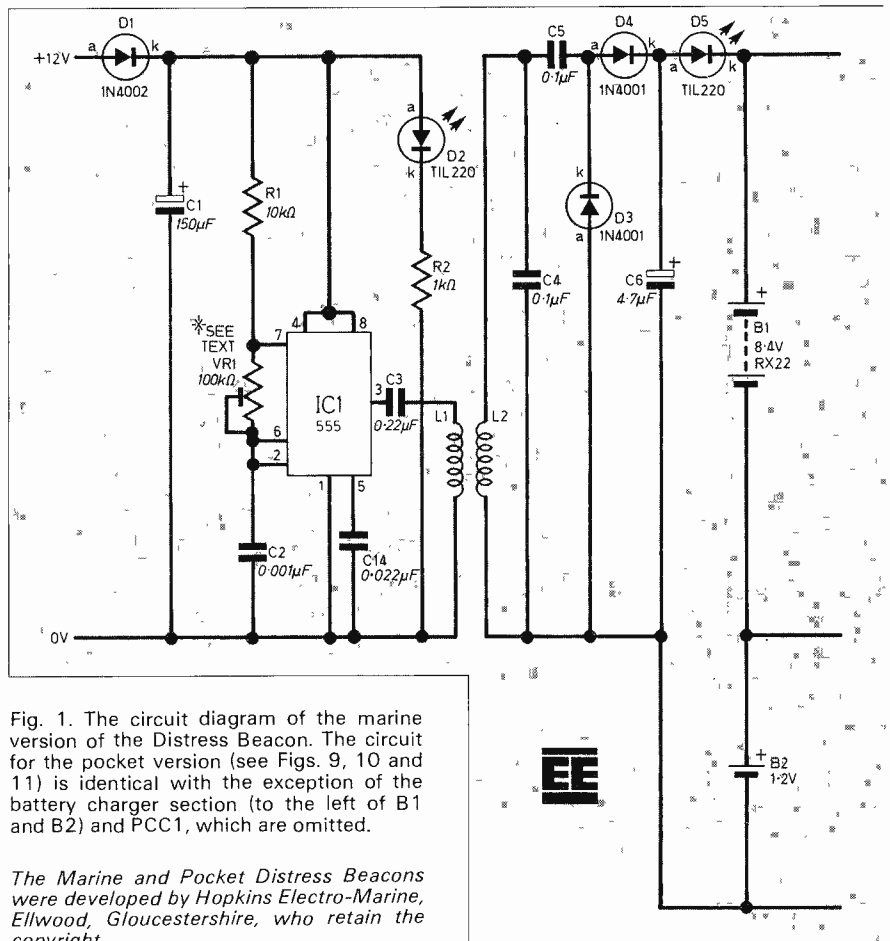

Fig. 1. The circuit diagram of the marine version of the Distress Beacon. The circuit for the pocket version (see Figs. 9, 10 and 11) is identical with the exception of the battery charger section (to the left of B1 and B2) and PCC1, which are omitted.

*The Marine and Pocket Distress Beacons were developed by Hopkins Electro-Marine, Ellwood, Gloucestershire, who retain the copyright.*



The circuit description for this version is identical with the exception of the battery charger section, as this is unnecessary, for the Pocket Beacon can use standard alkaline cells in place of ni-cads. The constructional details are given in a separate section.

## CIRCUIT DESCRIPTION

A single transistor oscillator based around TR1, working at a frequency of 20kHz converts the 8.4V battery supply via the secondary winding (S) of T1 and voltage doubler formed by D7, D8, C9 and C10 to a peak rail voltage in the order of 350V under no load conditions (see Fig. 1).

This peak voltage is, in reality, never achieved since current is constantly being bled via R5 to charge capacitor C11. At the same time, current is drawn from the h.t. supply through R6 and R7 to charge C12, and also through R10 to charge C13.

When the potential across C12 reaches a point approaching 80V (by which time C11 has charged up to 240V) the diacs (D9, D10) conduct, providing a trigger pulse to the gate of the triac, CSR1.

The triac turns on and shorts C13 to ground, and the rapid discharge through the primary of the trigger transformer (T2) induces a 3kV pulse in the secondary, which is fed to the glass envelope of

SPECIFICATIONS	
<b>Power Supply:</b>	<b>BEACON</b> Internal ni-cad rechargeable batteries. PP3 equivalent 8.4 volts for xenon supplies, HP16 equivalent ni-cad for l.e.d. flasher supply, or button type cell if available for considerable weight saving
<b>Current Drain:</b>	50mA peak
<b>Standby:</b>	(Upright during daylight) 0.5mA
<b>Inverted:</b>	(Day or night) xenon supply (B1) zero mA. (B2) l.e.d. flasher supply 0.5mA
<b>Flash rate:</b>	<b>Xenon</b> Approx. every 7 seconds over a period of 2 hours on a fully charged battery
<b>Energy Output of Light:</b>	0.5 Joules
<b>Supply:</b>	<b>CHARGER</b> 12V d.c.
<b>Current Drain:</b>	60mA nominal
<b>Frequency of operation:</b>	6.5kHz
<b>Charge rate:</b>	5mA nominal
<b>Efficiency:</b>	10% max.

the xenon tube (LP1). The normally non-conductive xenon gas is sufficiently energised by the high voltage pulse into a state of conduction, and the full charge held by C11 is able to discharge through the column of gas causing further excitation of the xenon atoms and the intense emission of light energy.

Once C11 has been discharged, the h.t. rail is reduced to zero volts, at which

no longer operate under daylight conditions. To test the completed unit, it is therefore necessary to mask PCC1 with a piece of opaque tape.

When the beacon is not in use, it is hung upside-down. An l.e.d. (D6) located at the top of the lamp housing, and run by the LM3909 (IC2) produces regular flashes of light, making the beacon easy to find at night should an emergency oc-

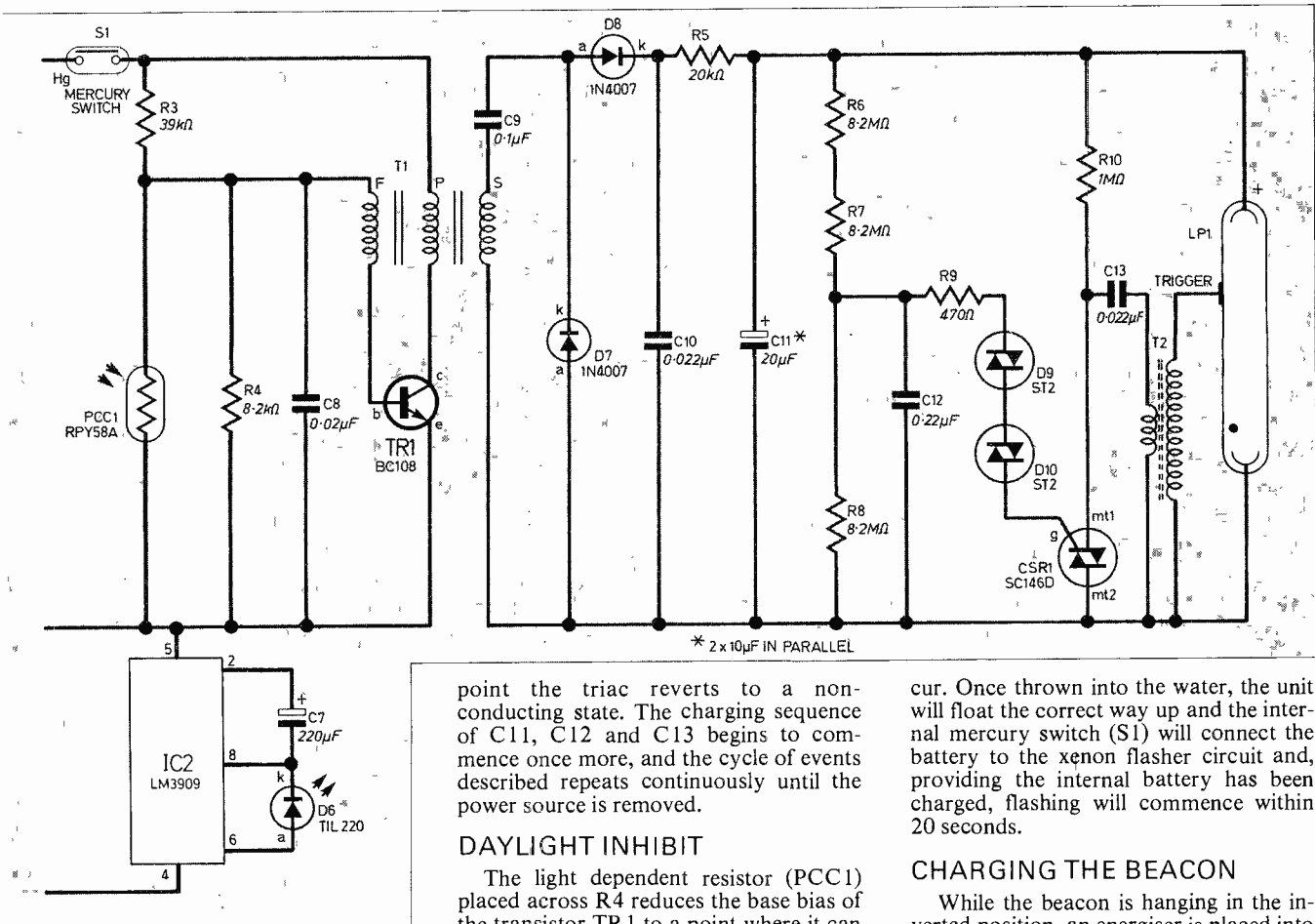

point the triac reverts to a non-conducting state. The charging sequence of C11, C12 and C13 begins to commence once more, and the cycle of events described repeats continuously until the power source is removed.

### DAYLIGHT INHIBIT

The light dependent resistor (PCC1) placed across R4 reduces the base bias of the transistor TR1 to a point where it can

cur. Once thrown into the water, the unit will float the correct way up and the internal mercury switch (S1) will connect the battery to the xenon flasher circuit and, providing the internal battery has been charged, flashing will commence within 20 seconds.

### CHARGING THE BEACON

While the beacon is hanging in the inverted position, an energiser is placed into

## Resistors

R1	10k $\Omega$
R2	1k $\Omega$
R3	39k $\Omega$
R4	8.2k $\Omega$
R5	20k $\Omega$
R6,7,8	8.2M $\Omega$ (3 off)
R9	470 $\Omega$
R10	1M $\Omega$
All $\frac{1}{4}$ W carbon $\pm 5\%$	

See  
**Shop  
Talk**

page 565

## Capacitors

C1	150 $\mu$ F 16V miniature elect.
C2	0.001 $\mu$ F $\pm 5\%$ polystyrene
C3,12	0.22 $\mu$ F polystyrene (2 off)
C4,5,9	0.1 $\mu$ F polystyrene (3 off)
C6	4.7 $\mu$ F 35V tantalum
C7	220 $\mu$ F 6.3V miniature elect.
C8	0.02 $\mu$ F miniature ceramic
C10,13,14	0.022 $\mu$ F polystyrene (3 off)
C11	2 x 10 $\mu$ F 450V(=20 $\mu$ F) miniature elect. (in parallel, see text)

## Semiconductors

D1,3,4	1N4001 (3 off)
D2,5,6	TIL220 0.2in red l.e.d. (3 off)
D7,8	1N4007 (2 off)
D9,10	ST2 diac (2 off)
TR1	BC108 npn silicon
CSR1	SC146D triac
IC1	555 timer
IC2	LM3909 l.e.d. flasher

## Miscellaneous

VR1	100k $\Omega$ miniature preset
LP1	xenon tube (Maplin YQ62S)
T1	see separate list
T2	trigger transformer (Maplin YQ63T)
B1	RX22 8.4V ni-cad (PP3 equivalent)
B2	1.2V ni-cad cell (see text)
S1	mercury switch
L1	} see separate list
L2	

**Printed circuit boards:** *EE PCB Service*, Order code 8309-04; raw materials for casing (see separate list); small case for charger, 35 x 35 x 20mm; battery connector; 7/0.2mm wire; small-bore aluminium tube; spacer, 15mm long; eye-hook; foam pads; silica gel in muslin bag; FX2238 ferrite core plus bobbin (for T1); silicone rubber; assorted screws (non-corrosive); 40 s.w.g., 36 s.w.g. and 30 s.w.g. enamelled copper wire.

## Transformer (T1)

### Windings

Primary 12 turns 30 s.w.g. enamel wire (marked P)  
Feedback 3 turns 30 s.w.g. enamel wire (marked F)  
Secondary 240 turns 36 s.w.g. enamel wire (marked S)

Wind first the primary and feedback windings alongside each other. Mark the start and finish of each winding, and cover this first layer with one turn of the paper tape. Next wind on the secondary. Care must be taken to lay the windings neatly, otherwise the bobbin will not enter the cores. When complete, finish off with one layer of paper tape to hold the windings in place and add fine bore plastic sleeves to the start and finish of the three windings. Assemble the bobbin and cores holding them together with a screw and nut, and immerse the transformer in hot paraffin wax.

## Inductors

### Energiser (L1)

250 turns 40 s.w.g. wire wound over a length of 10mm on a 20 x 6mm diameter ferrite rod (Fig. 6)

### Receptor (L2)

220 turns of 36 s.w.g. wire wound over a length of 10mm on a glass-fibre tube (Fig. 7)

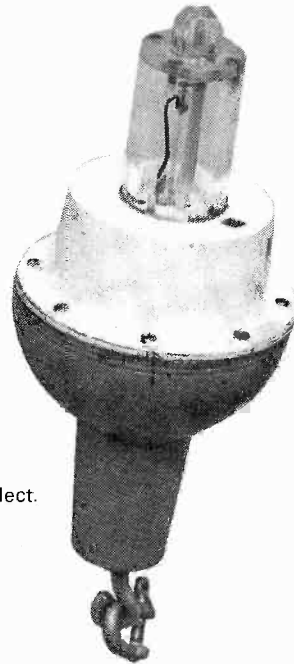

COMPONENTS  
approximate  
cost **£18.00**  
excluding case

a receptor. In the charger, a 555 timer running at a frequency of 6.5kHz provides pulses that are fed to the energiser coil, L1, producing an alternating magnetic field.

This field induces an alternating current in the receptor coil, L2, which is rectified to produce the d.c. potential necessary for charging the ni-cads. An l.e.d. (D5) will light, indicating that charge is being transferred into the beacon.

## CHARGER CIRCUIT

A 555 timer (IC1) running in the astable mode at 6.5kHz provides pulses which are fed via C3 to the energiser coil, L1. The signal from L1 passing through the beacon shell induces a resonant field in the tuned circuit formed by the receptor coil L2 and capacitor C4. The voltage produced across L2 is further increased by the doubler network formed by D3, D4, C5 and C6 to provide the charging potential required to the ni-cads B1 and B2.

The in-line l.e.d. (D5) indicates that charge is passing into the batteries, which for the cells specified will be reached in a little over 24 hours. The nominal charging rate for the ni-cads is 15mA—which is the maximum permissible current once the cells reach full charge.

Since the charger unit described here delivers well below this figure, it may be left on charge for considerable periods without risk of damage to the batteries. This ensures that the beacon is always at peak operational performance. A very slight warming of the energiser coil is normal when the charger is in use.

# CONSTRUCTION

## CIRCUIT CONSTRUCTION

Few problems should be encountered in the circuit construction, providing miniature components are used wherever possible in order to save space and weight. Perhaps the most tedious job is cutting out two identical discs of circuit board, 65mm in diameter. A complete set of p.c.b.s for the marine version of the Distress Beacon is available from the *EE PCB Service*, Order code 8309-04.

The transformer (T1) winding details are given under the components listings, and as can be seen from the first p.c.b. layout (Fig. 2), connections into the p.c.b.1 will be found to be straightforward. The secondary windings marked G and S have to be connected to p.c.b.2 with short, well insulated leads, before the two boards are screwed together.

The two low-voltage windings are connected as follows: Feedback (finish), Primary (finish), Feedback (start), Primary (start), as viewed from left to right on the component overlay drawing.

Ensure that the mercury switch (S1) is mounted in such a way that battery, B1,

# DISTRESS BEACON

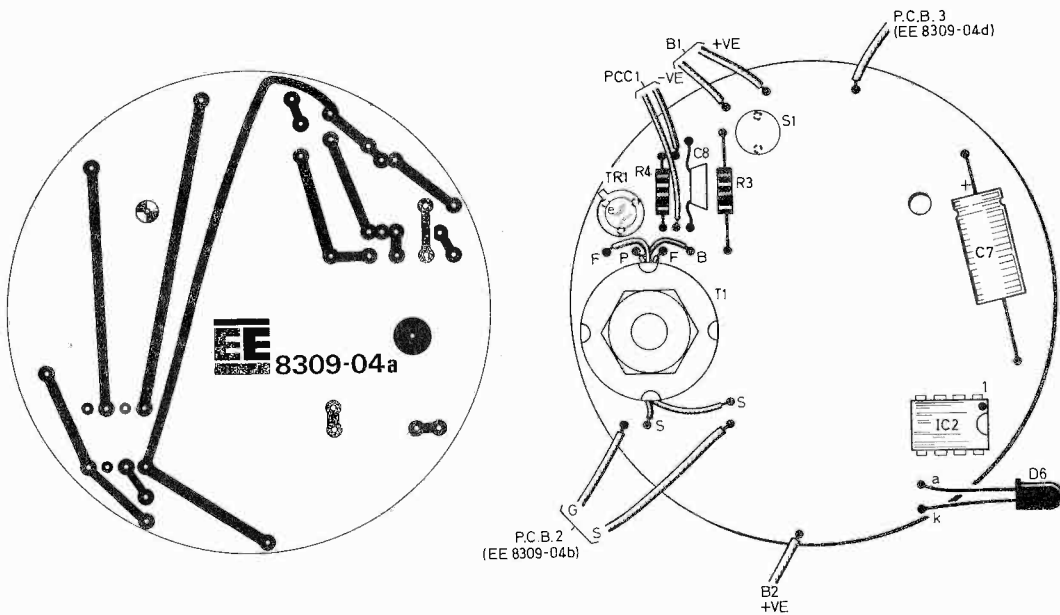
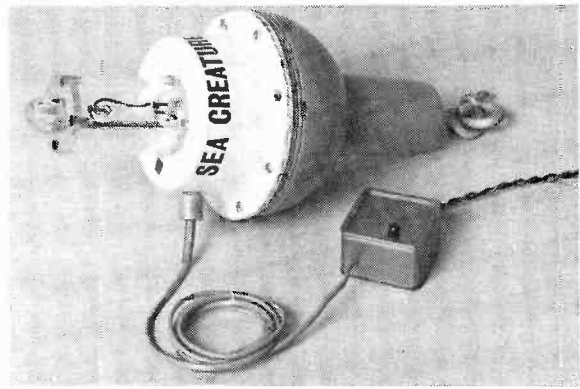

Fig. 2. The component layout and full-size artwork of p.c.b.1. Note that D6 is mounted at the top of the Beacon housing. Battery B2 is located on the space in the centre of this board.

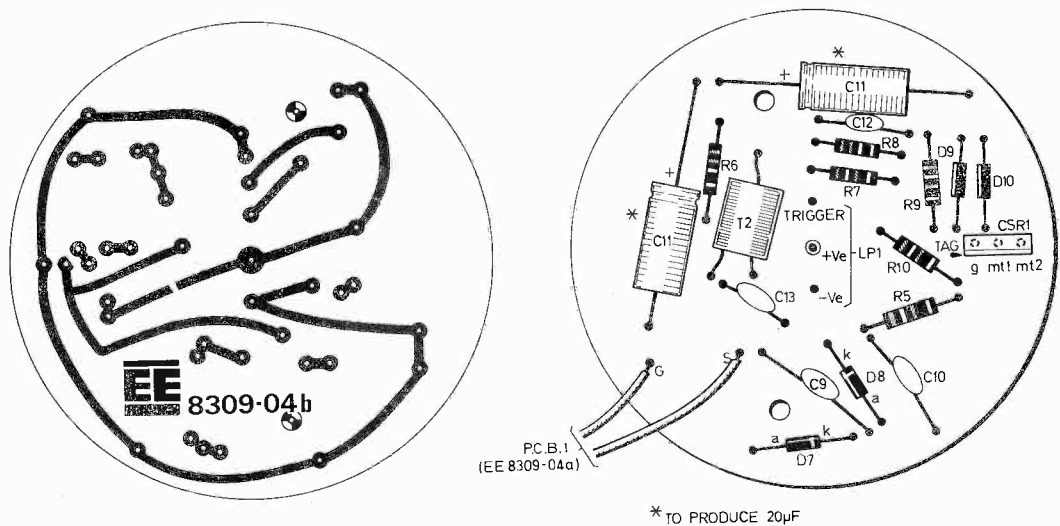

Fig. 3. The component layout and full-size artwork of p.c.b.2. The xenon tube, LP1, is mounted onto stiff wire supports in the holes indicated (see also Fig. 4).

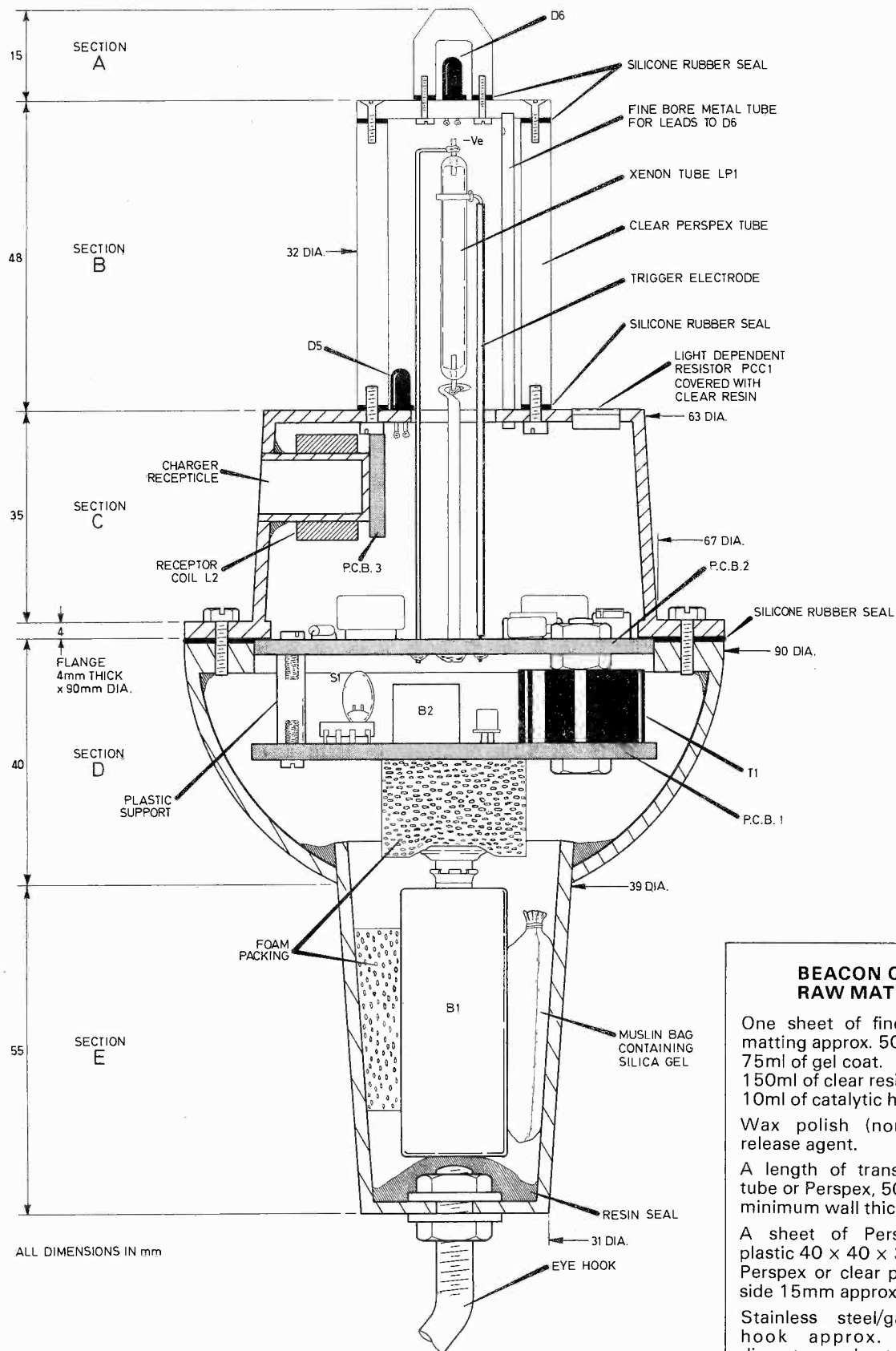

Fig. 4. A cross-section through the Distress Beacon housing giving all key dimensions and component locations. This diagram is drawn actual size.

### BEACON CASING RAW MATERIALS

One sheet of fine glass strand matting approx. 500 x 500mm.  
75ml of gel coat.  
150ml of clear resin.  
10ml of catalytic hardener.

Wax polish (non-silicone) or release agent.

A length of transparent plastic tube or Perspex, 50 x 32mm and minimum wall thickness 5mm.

A sheet of Perspex or clear plastic 40 x 40 x 3mm thick.  
Perspex or clear plastic block of side 15mm approx.

Stainless steel/galvanised eye hook approx. 5mm shaft diameter, and cut if necessary to a length of 40mm.



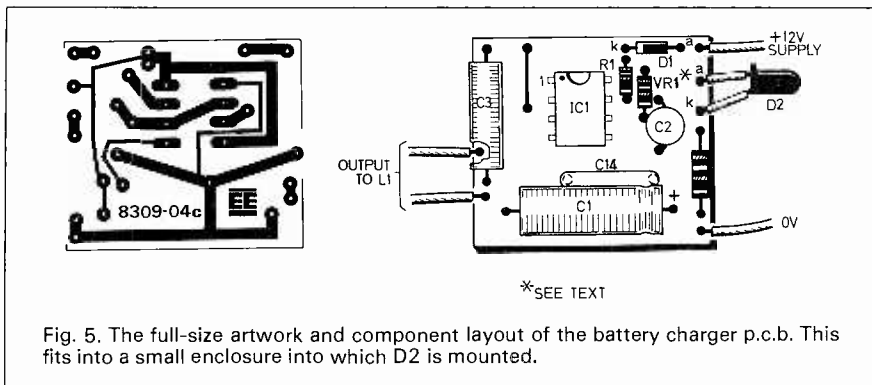

Fig. 5. The full-size artwork and component layout of the battery charger p.c.b. This fits into a small enclosure into which D2 is mounted.

is switched on only when the beacon is in the upright position. Note also that the light dependent resistor (PCC1) is not mounted on the printed circuit board, but is located as shown in Fig. 4 in the upper half of the beacon casing.

The battery, B2, that operates the l.e.d. flasher should be mounted on p.c.b.1 and soldered into position. The current consumption of IC1, the LM3909, is so low that a button-sized ni-cad may be used with a considerable weight saving.

As shown in Fig. 4, the two circuit boards are mounted on top of one another, and the screw that secures the potcore of T1 should be of sufficient length to pass through both p.c.b.s in order to bolt the two boards together. A plastic support drilled to take a self-tapping screw at each end should be positioned at a convenient place on the opposite side of the two boards in order to keep them parallel. Ensure that none of the components on p.c.b.1 are touching the printed track of p.c.b.2.

Three in-line holes at the centre of p.c.b.2 mark the position of the xenon tube supports which also serve as power connectors. A strip of brass 50mm long and 0.8mm thick was used as the central positive supply support, and a length of stiff wire cut to the correct length and with a 90 degree bend at the top end for the negative supply support. The trigger supply wire should be well insulated to minimise voltage losses en route to the glass envelope.

The l.e.d. (D6) supply which runs to the top of the lamp housing was positioned through a fine bore aluminium tube obtained from a model shop. The purpose of this tube is to keep the l.e.d. supply neatly stored away from the high voltage wires supplying the xenon.

### TESTING

On completion of the circuit boards p.c.b.1 and p.c.b.2, connect up the battery, B2, and check that the l.e.d. flasher is operational. Next, with the PPC1 masked with opaque tape or temporarily disconnected, connect B1 and check that the current drain is between 40 and 50mA. Current in excess of this probably indicates a fault in the oscillator or h.t. winding of T1.

With a testmeter across C11, the voltage should steadily rise to 240V d.c., by which time the xenon should have fired. If no voltage exists across C11, disconnect R5 and check to see if there is a voltage across C10 in the order of 300V d.c. If not, check that the diodes D7 and D8 are properly positioned, and that the h.t. connections between the two boards are sound.

Should the voltage across C11 reach 240V without the xenon firing, the circuit should be switched off before the voltage rating of the capacitor is exceeded. Check the triac (CSR1) connections, trigger transformer and polarity of the xenon supplies.

### CHARGER CONSTRUCTION

Construction of the charger p.c.b. is straightforward, and the layout is shown in Fig. 5. The prototype was housed in a miniature "Twinings Tea" sample caddy, reduced in height to measure 20 x 35 x 35mm. Any case of similar dimensions can be used.

Considerable care must be taken, however, in winding the coils L1 and L2 in order to minimise losses.

### ENERGISER COIL

Following the dimensions given in Fig. 6, wind one turn of thin sticky paper onto a 20mm long by 6mm diameter ferrite rod. Starting 2mm from one end of the rod, wind on 250 turns of 40 s.w.g. enamelled wire in neat layers over a length of 10mm of rod.

Referring to Fig. 6A, pass the energiser feed wire through the base of a small plastic cap (as used to seal pill tubes). Slip in place a short length of plastic sheath and strip and tin the ends of the wire.

Prepare a small quantity of resin, and pour into the plastic cap as shown in Fig. 6B. When the resin has set, position the wires so that they are parallel and able to accommodate the diameter of the ferrite rod which should be placed in position by means of a further blob of resin (Fig. 6C).

When sufficient time has elapsed for the resin to harden, solder the coil ends to the feed wire, and pour a further quantity of resin into the cap to cover the first three millimetres of the ferrite (Fig. 6D).

Lastly, the exposed length of ferrite and coil windings have to be covered in a regular layer of resin. One way to do this is to find a short length of plastic tube of 8 to 9mm internal diameter, coat the inside with a layer of resin, and coat the ferrite and coil.

Slip the plastic tube over the ferrite until the resin has set hard, and then carefully remove both the plastic tube and the plastic cap. The energiser coil will have a regular finish as in Fig. 6E.

### RECEPTOR COIL

Find a former with an outside diameter of no more than 0.5mm greater than the

Fig. 6. The step-by-step construction of the energiser coil, L1, shown in cross-section. Note that the windings must be completely enclosed in resin.

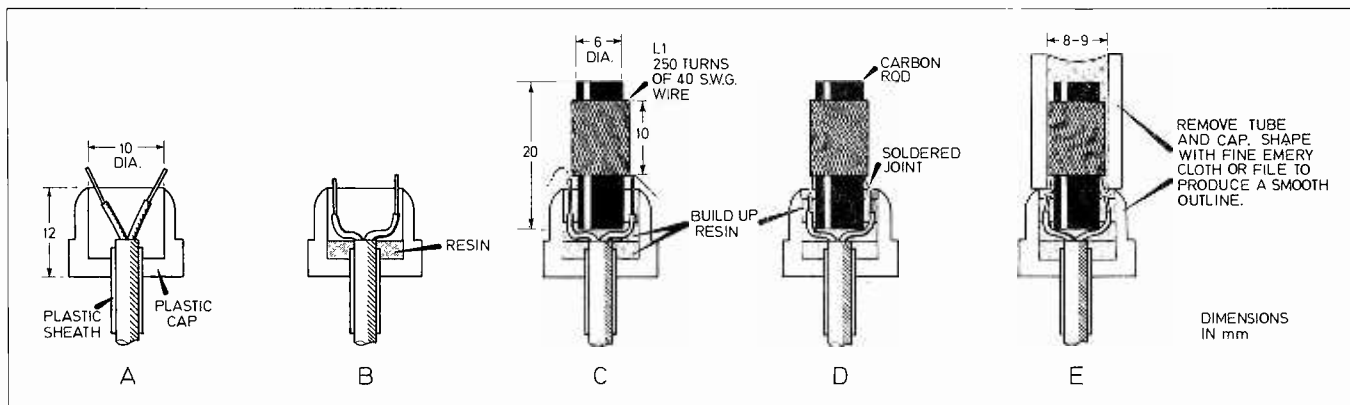

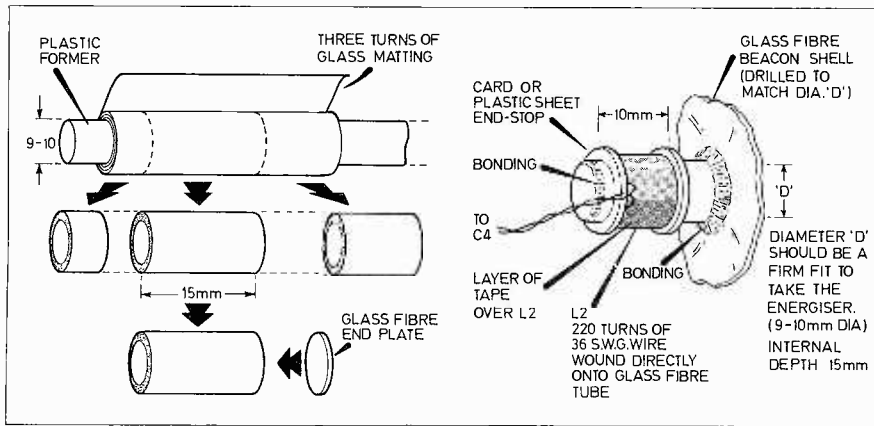

Fig. 7. The constructional details of the receptor coil, L2. Note that it should be tested before bonding to the Beacon shell.

diameter of the completed energiser (disregarding the enlarged region where the supply lead enters). Clean and polish the surface with furniture polish, and apply a thin regular layer of gel coat. When the gel has hardened, apply three turns of fine glass matting and resin (Fig. 7). When set, ease out the former and cut off the ends to form a tube 15mm in length.

Using a waste fragment of glass-fibre from the beacon casing, cap one end of the tube as shown by applying gel coat to both surfaces, thus effecting a waterproof seal.

Starting 2mm from this join, wind onto the tube 220 turns of 36 s.w.g. enamelled wire in compact layers over a distance of 10mm. Cardboard stops glued into position on the tube will locate the winding within these limits.

At this stage the coil should be checked before it is permanently bonded against a hole drilled through the beacon casing. Space inside the beacon is very limited and care should be taken to select miniature components for the receptor board which, only if space permits, should be bonded to the receptor coil, otherwise it will have to be located elsewhere inside the beacon shell. The layout of the receptor coil p.c.b. is shown in Fig. 8.

For testing purposes, temporarily link receptor coil (L2) to receptor board and

link batteries B1 and B2 in circuit observing correct polarity. Place energiser coil into the receptor tube and connect charger board to a 12V d.c. supply. D5 should light indicating that charging has commenced. Check that current drawn by the charger board is between 40 and 60mA, and that the charging current into the battery is 5mA,  $\pm$  1mA.

VR1 on the charger board should be set for maximum resistance, that is, 100 kilohms. Reduce this value slightly to see if the efficiency of coupling is improved. When the best position for VR1 has been found it may be replaced by a resistor of fixed value.

Excessive currents drawn by the charger board may be trimmed by a low value resistor placed in series with the supply—typically 20 to 30 ohms. Further adjustments to compensate for the variation in the properties of the inductors L1 and L2 may be effected by slightly altering the value of the tuning capacitor C4.

## BEACON CASING

Glass-fibre is not in itself waterproof, and thus the outer surface of the beacon is coated in a layer of gel coat, which is obtainable in a variety of colours. You will find that most small boat repair yards will not only be willing to supply gel coat

in the small quantities required, but will also supply you with the rest of the materials for moulding the beacon, providing that you are suitably equipped with an assortment of clean jam jars.

A catalyst has to be mixed in with both gel coat and resin in order to initiate the hardening process. The catalyst contains the toxin Styrene, and should be handled with utmost care, and only used in the recommended proportions as given by the supplier. Usually mixing proportions are in the order of one part hardener to fifty parts of resin/gel coat.

Except for the lamp housing (Section B, Fig. 4), which should be made from clear Perspex or plastic tube, the rest of the beacon was moulded with the following items:

- Section C—"Chambourcy" cheese-cake container.
- Section D—Top cover of an "Airball" air freshener.
- Section E—A "Blue Flush" W.C. treatment container.

Should any of the above be unavailable, the great variety of plastic lids and caps found on supermarket shelves should provide a near equivalent.

## MOULDING

Each container should be washed, dried, and polished with wax polish. Next, a thin layer of gel coat, with hardener added, was applied using a small glue brush to the inside of the container. When the gel coat had started to harden, a second thin layer was applied on top.

Fine glass matting was then applied in small strips, each strip being firmly pressed onto the gel coat by means of a stippling action with the glue brush dipped into resin. Three layers of glass matting and resin should be sufficient to give the required strength and rigidity.

When the three sections C, D and E have been moulded, a circular hole should be cut through the centre of the base of section D, and the rim of section E bonded in place using glass matting and resin. Seal any cracks on the outside about the joint with gel coat, and cover with Sellotape until cured.

A lip must be formed around the internal circumference of the top of section D, and this may be achieved by trimming an inverted "mousse" container mould, and inserting it into the glass-fibre shell to form a trough, 5mm in depth, between the mousse mould and shell. Into the formed trough, a mixture of resin and glass-fibre should be poured until it is flush with the rim of the casing. When set, the mousse mould should be removed, and the newly formed lip ground smooth using an abrasive sheet placed on a flat surface.

## FLANGE

A flange has to be formed onto section C in order that it may be bolted to section D when the beacon is completed. Using two plastic or Formica sheets, apply gel coat to one surface, and when set, lay down glass matting and resin until a

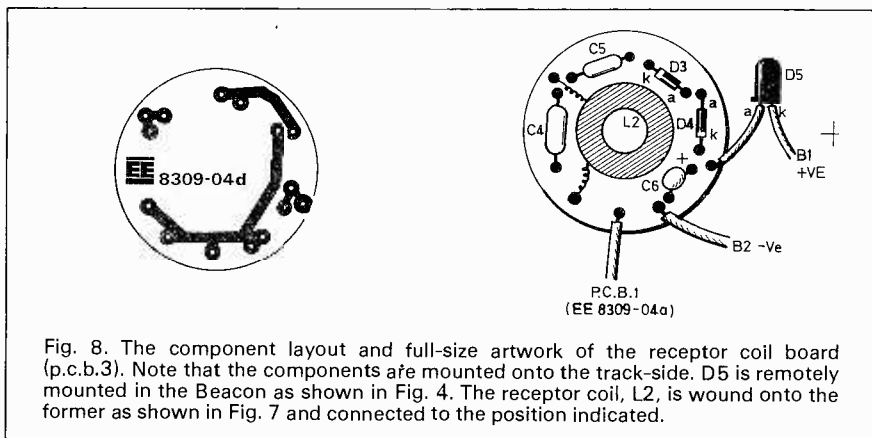

Fig. 8. The component layout and full-size artwork of the receptor coil board (p.c.b.3). Note that the components are mounted onto the track-side. D5 is remotely mounted in the Beacon as shown in Fig. 4. The receptor coil, L2, is wound onto the former as shown in Fig. 7 and connected to the position indicated.

depth of 4mm has been achieved. Apply gel coat to one surface of the second plastic/Formica sheet and place firmly, gel coat downwards, on top of the first sheet to form a gel-glass-fibre-gel sandwich.

When cured, the plastic sheets may be removed and the flat glass-fibre sheet cut with a small saw to form the flange to be bonded to section C.

Eight screw holes should be marked and drilled at equal intervals around the middle of the flange, and corresponding holes in the lip of section D.

Four holes should be drilled in the top of section C, and corresponding holes carefully drilled in the base of the clear plastic tube of the lamp housing. Four more holes are required at the other end of the lamp housing, and a small disc of Perspex or plastic cut and drilled to fit. The l.e.d. flasher (section A) is cut from a 15mm block of clear plastic, drilled to accommodate the l.e.d. and securing bolts, and polished using a 400 grade abrasive sheet followed by Brasso-type metal polish.

The base of section E should be drilled to take an eye-hook cut to a length of 40mm and with a shaft diameter of 5mm. This should be secured with a nut and washer on each side of the glass-fibre shell, the thread being first dipped in gel coat, and sealed on the inside of the beacon with a further amount of gel coat as illustrated in Fig. 4.

Assemble the complete beacon casing to ensure that a good fit has been achieved between the mating surfaces. Non-rust screws should be selected with regard to the thickness of materials through which they have to pass, and threads must be tapped with utmost care.

## FINAL ASSEMBLY

During the final assembly of the beacon, all mating surfaces and screw threads are coated in silicone rubber to ensure total sealing against water.

Cut a small slot in the centre of section C just large enough for the xenon tube to pass through into the lamp housing, also a hole for the PCC1 as positioned in Fig. 4. Bond PCC1 into position using clear resin on the external surface to permit passage of light, and back with a small layer of resin and glass matting on the underside of section C to give mechanical rigidity.

Bolt section B to C, using silicone rubber to seal. Drill a 3mm diameter hole adjacent to the internal wall of the lamp tube through the top of section C. Insert a 54mm length of small-bore metal tube through this hole, so that it passes up to the top of the lamp tube.

Install D6 into the clear plastic l.e.d. housing and screw into position on the 32mm diameter plastic disc that seals the top of the lamp tube. Solder a couple of thin wires onto the l.e.d. leads, insulate the solder joints with a little plastic sleeving, and pass the two wires down the fine metal tube previously positioned within the lamp tube. Screw l.e.d. housing assembly onto the top of the lamp tube

and feed through any excess wire from the l.e.d. assembly down into section C.

Drill a small hole through p.c.b.2 at any convenient position, away from parts of the circuit bearing high voltage, and pass the lead wires from the l.e.d. and PCC1 through this hole. Insert xenon through the hole in the centre of section C, solder D6 and PCC1 wires to their positions on p.c.b.1. Add small blobs of silicone rubber to the perimeter of p.c.b.2 and place the circuit board against the protruding flange of section C.

Check that B2 is connected and that D6 is operational. Connect battery B1 and place it into the base of section E, along with a small bag of silica gel to absorb any moisture that may build up inside the beacon once sealed. Add a small quantity of foam packing, if necessary, to prevent movement within the battery compartment.

Connect charger wires to the batteries, cover PCC1 and check that xenon flashes when the lamp housing is vertical. Connect up external charger circuit, insert energiser coil into the recess in the beacon shell and check that the charging l.e.d. (D5) operates.

Glue a piece of foam rubber to the base of p.c.b.1 so that it helps support the circuit assembly. Smear silicone rubber onto the two mating surfaces of sections C and D, working the sealer well down into the eight screw holes, and screw the two sections together.

Hang the beacon in an inverted position and allow the silicone rubber seals to harden, during which time the charger may be inserted and the beacon is ready for use within 24 hours.

## NOTE ON BATTERY SUPPLIES

Considerable difficulty was experienced in obtaining ni-cad cells of suitable size and capacity. Varta are able to supply the 170 DK, of which eight are required (seven for xenon, one for l.e.d. flasher). However, since Varta impose a £30 small order charge, it was found to be more economical to obtain a couple of PP3 ni-cad equivalents. One "PP3" was used to power the xenon, the other was broken up and one cell\* removed to power the l.e.d. flasher.

\* Equivalent to Varta 100 DK0.

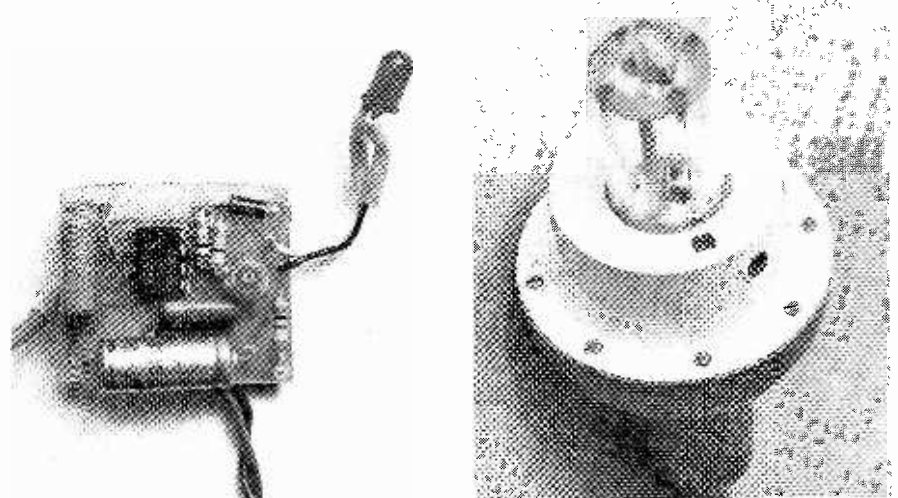

The charger p.c.b. (above left) is mounted into a small plastic case. The top view of the Distress Beacon (above right) shows the light dependent resistor and the receptacle for the charger coil. Below, the shape of the charger coil can be seen.

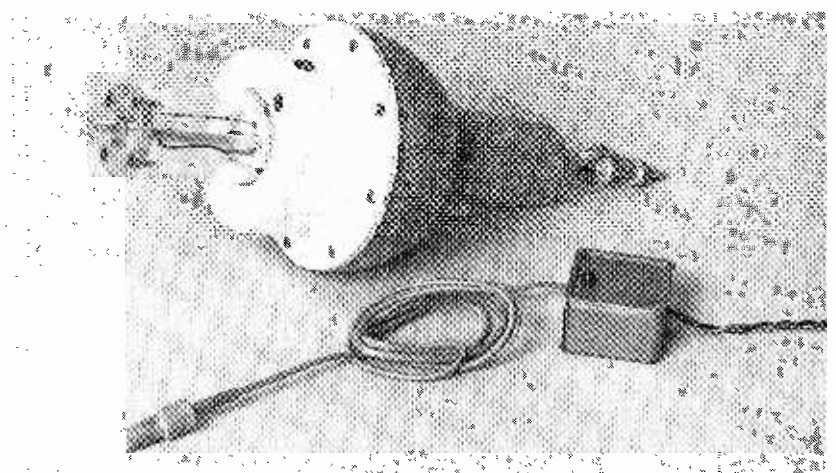

# POCKET DISTRESS BEACON



THE pocket Distress Beacon is designed for non-nautical applications and as such, does not need to be in a sealed case. Therefore, the inductively coupled charger and the rechargeable batteries are not required and replaceable alkaline batteries (the Duracell type) can be used.

Referring to the main circuit diagram in Fig. 1; all the circuit to the left of the batteries B1 and B2 is omitted (that is, D1 to D5, C1 to C6, R1 and R2, L1 and L2, VR1 and IC1). S1, the mercury switch, is replaced with a normal slide switch and the light dependent resistor PCC1 is also left off. All other components are used and, for convenience, the references are unchanged on the constructional diagrams.

## P.C.B. ASSEMBLY

Preparation of the printed circuit board shown in Fig. 9 is fairly straight-

forward, the only special precautions necessary are in the mounting of the pot-core for T1 and the two electrolytic capacitors forming C11.

These components need to be mounted in cut-outs in the p.c.b. due to the height restrictions imposed by the Lascar instrument case (as used for small hand-held instruments) employed in the design.

The pot-core of T1 is held together with a nylon screw. A nut is not used to secure the two halves together, but instead the end of the screw is passed through a spring steel clip (as used in the motor trade for securing self-tapping screws), and holding the pot-core firmly, the excess length of the nylon screw is trimmed, and the remaining stub melted over the clip with a hot iron.

The transformer was thoroughly sprayed with "Holts" ignition sealer to maintain interwinding insulation under

damp conditions, and it is suggested that when complete, the whole circuit board is treated with several coats of sealer also.

Resistors, diodes and diacs should be inserted into the p.c.b. first as the capacitors will have to have their wire ends pre-formed in order that they may be mounted horizontally above neighbouring components.

The board is available from the *EE PCB Service*, Order code 8309-05.

## LAMP REFLECTOR

The curved reflector for the xenon tube was made from a 1mm thick sheet of plastic 70 x 40mm. This was gently heated in hot water until pliable, then set into shape by pressing over the side of a spent 55mm aerosol can.

When cool, the plastic sheet will retain its shape, and a 34mm wide strip of aluminium foil may be glued into position as shown in Fig. 10 to form the reflective surface.

Fig. 10 shows the dimensions of the xenon tube terminal supports which are passed through the reflector sheet, and glued into position. Ensure that the aluminium foil does not come into contact with the xenon tube supports otherwise the power supply to the tube may be shorted out.

## POWER SUPPLIES

A 9V alkaline PP3 will fit snugly into the case in the space provided by Lascar. (Note: It was found that some makes of battery were too wide, and it was impossible to close the case completely. Allowing

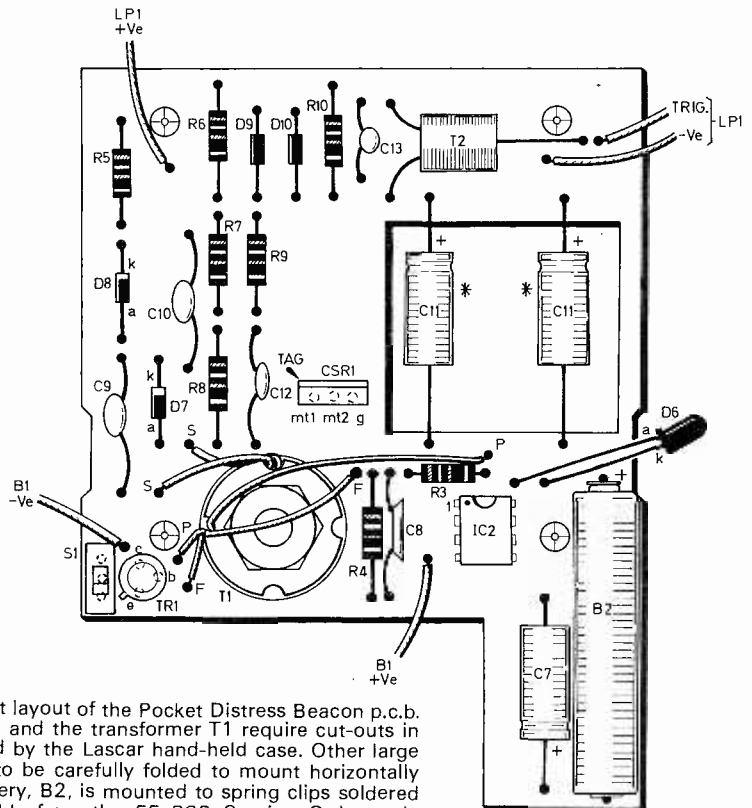
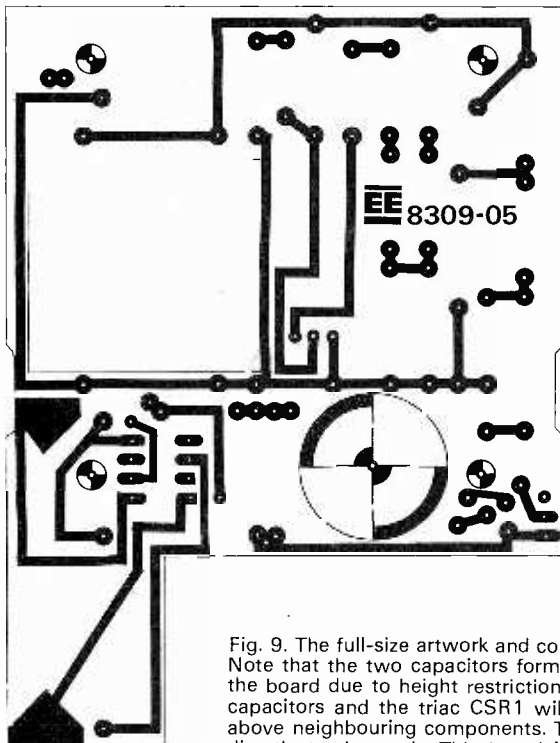

Fig. 9. The full-size artwork and component layout of the Pocket Distress Beacon p.c.b. Note that the two capacitors forming C11 and the transformer T1 require cut-outs in the board due to height restrictions placed by the Lascar hand-held case. Other large capacitors and the triac CSR1 will have to be carefully folded to mount horizontally above neighbouring components. The battery, B2, is mounted to spring clips soldered directly to the p.c.b. This board is available from the *EE PCB Service*, Order code 8309-05.



for production spreads, Duracell and Berc were found to fit well.)

The positive wire from the battery clip is soldered to a point indicated on the layout diagram, Fig. 9, and the negative to the miniature slide switch terminal is also shown.

The l.e.d. flasher is powered by a 1.5V battery (size AAA) and spring terminals should be soldered directly to the p.c.b. in order that the battery may be replaced easily.

The supply to l.e.d. D6 is taken from points located on the p.c.b. near to IC1. A small hole drilled through the mid-point of the top section of the case as shown in Fig. 11 is used to locate D6. This continuously flashing l.e.d. serves to locate the unit quickly if dropped or misplaced.

A lanyard should also be fixed to the casing, and this may be achieved by passing a length of nylon or polythene cord through a small hole drilled just below the casing catch. The end of the cord is then heated with a flame and flattened into a disc so that it will lie neatly between the battery and casing wall, and cannot be pulled out.

## REFLECTIVE STRIP

A Perspex or clear plastic sheet should be cut to fit the case to protect the xenon tube. There is plenty of room to bond and seal, with silicone rubber, the window to the inside surfaces to the case. To this window, on either side of the xenon tube, reflective strips (as used on disco equipment and "custom" cars) are glued into position and act as a signal device under sunny conditions.

Amber reflective plastic sheet, as used for car rear number plates, is stuck to the upper main surface of the case. The rear surface of the pocket beacon is covered with Velcro, and the fixing patch of the fluffy nylon should be sewn to a suitable area of the wearer's anorak or rucksack.

It is advised that the mating surfaces of the casing halves are covered with sticky tape to prevent moisture entering, and a rubber gasket cut to fit over the slide

switch, and positioned between the switch and internal casing.

## OPERATION

In case of difficulties encountered while climbing or walking, the unit described will only be of use if used sensibly. Depending upon the quality of components used, and the care taken in winding T1, battery life will be found to be between three and five hours in the continuous flashing mode.

All walkers and climbers should always leave details of their itinerary with a friend or official so that action may be taken should they become overdue, and under such circumstances the pocket beacon used at regular intervals of time will remain usable far in excess of the three to five hours continuous running.

At temperatures below freezing, the beacon should be kept in a pocket until required to prevent the battery voltage

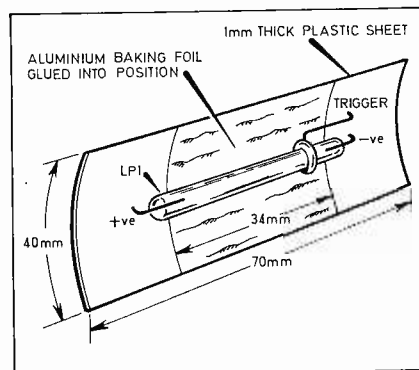
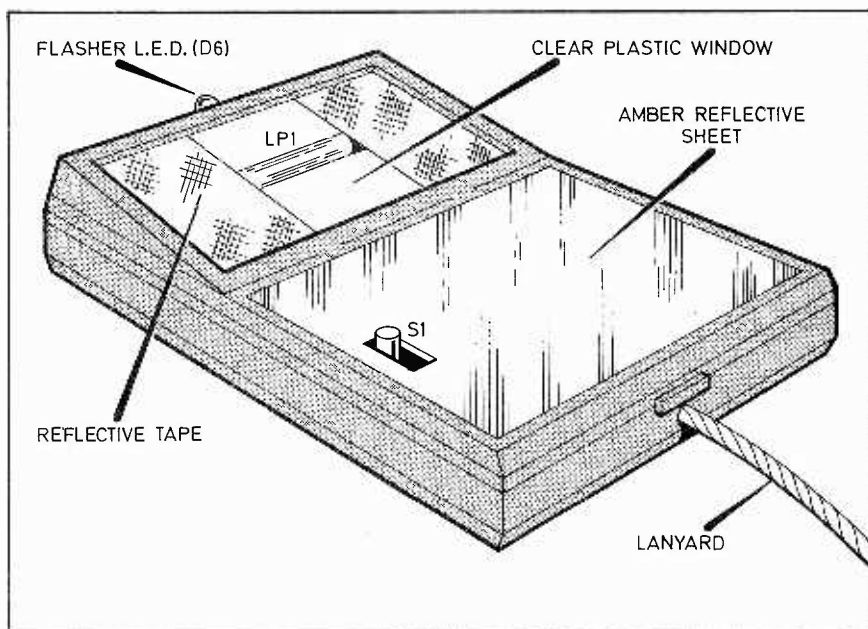

Fig. 10. Constructional details of the xenon tube reflector. The tube supports should be formed from well insulated, stiff wire.

from falling to a point where the unit would become inoperative. It is wise to carry a spare battery for your beacon at all times—as well, of course, for your conventional torch. □



# Is Your Youngster's Future Worth 90p per Month?

Electronics and computer-based industries offer many job opportunities to the technically trained. Your son or daughter's career prospects could be enhanced if they have a knowledge of electronics.

Our twelve-part series *Teach-In 84* has been planned with this object in view. An ideal home-study course with practical experiments, easily performed without soldering.

Make sure of your copy of *EVERYDAY ELECTRONICS* by placing a firm order with your Newsagent NOW!

# ELECTRONICS and the ELECTRON

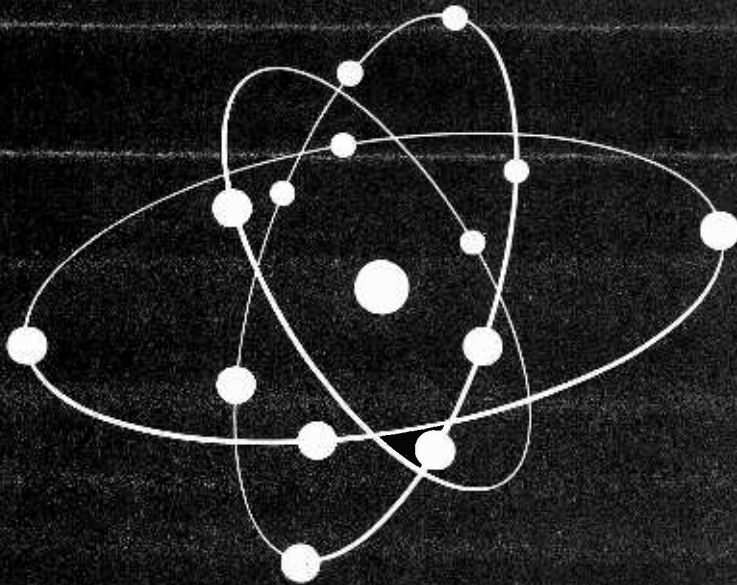

## Part 5 DOPED SEMICONDUCTOR MATERIALS BY J. B. DANCE

LAST month we discussed the mechanism by which conduction occurs in pure semiconductor materials. Conduction in such materials is known as "intrinsic conduction". In practical devices pure or intrinsic semiconductor materials are seldom used. Such devices employ semiconductor materials containing very small amounts of impurity elements which modify their properties considerably.

This month we shall consider how conduction occurs in semiconductor materials containing small amounts of doping elements as impurities. There are two main types of such materials, the one being known as *n*-type in which the charge carriers are the negative electrons and the other is known as *p*-type in which the charge is carried by positive holes.

### *N*-TYPE MATERIAL

Let us first consider a silicon crystal lattice similar to the one we discussed last month but, as shown in Fig. 5.1, one of the atoms of silicon (Si) has been replaced by an atom of arsenic (As). When the arsenic has formed the four bonds to

neighbouring silicon atoms, it still has an electron left over which is not taking part in the bond formation.

This extra electron present in the arsenic atom is not so firmly attached to the arsenic atom as any of the other electrons in the lattice. In other words only a small amount of thermal energy needs to be acquired by the electron to enable it to leave the arsenic atom and to wander through the crystal lattice. Thus this electron can lead to conduction in the crystal.

The conductivity of silicon can be greatly increased by the addition of very small amounts of elements such as arsenic. Even one part of arsenic in ten million parts of silicon or germanium can greatly affect the electrical properties of the material. The number of electrons provided by the impurity atoms is usually far greater than that provided by movement of electrons from the valency band to the conduction band.

The impurity atom in Fig. 5.1 provides an electron without creating a hole, since the arsenic atom has its full complement of four electrons in chemical combination after the extra electron has departed.

Conduction in materials of this type is therefore almost entirely by negative electrons, the small number of holes providing a very small contribution.

Silicon doped with arsenic is known as *n*-type material, since negative charge carriers (electrons) carry the current. The arsenic atoms are known as "donor" atoms, since they donate electrons to the silicon lattice.

### *N*-TYPE ENERGY BANDS

The energy band diagram of an *n*-type material is shown in Fig. 5.2. It should be noted that this is rather similar to the energy band diagram for a pure semiconductor material, but there are two important differences. The first is the presence of the donor band just below the conduction band.

Only a small amount of energy is required to lift an electron from the donor band into the conduction band. This results in the second difference in the energy band diagram, namely that there are many more electrons in the conduction band than in the case of the pure semiconductor material.

### *P*-TYPE MATERIAL

Another type of semiconductor material is shown in Fig. 5.3, in which the central atom of silicon (Si) has been replaced by an impurity atom of boron (B). The boron atom has only three valency electrons as opposed to the four of silicon. There is therefore a hole or vacancy by the boron atom which can be filled by an electron from the valency band of another atom.

As shown in Fig. 5.3, an electron can move from a neighbouring silicon atom to fill the hole by the boron atom, in which case the boron atom will have four chemical bonds to neighbouring atoms instead of the three shown in Fig. 5.3. In addition, the silicon atom which donates the electron to the boron will have a hole left by it and an electron from another silicon atom can fill this hole. Thus this movement of electrons can be considered as a movement of a hole, as discussed last month.

Silicon or another semiconductor material containing atoms of an element like boron as an impurity, is known as *p*-type material, since conduction is considered to occur by the movement of positive holes (although it is actually the movement of many negative electrons which causes the conduction).

### *P*-TYPE ENERGY BANDS

The energy band diagram of a semiconductor material containing impurity atoms such as boron, is shown in Fig. 5.4. The energy band gap of the material is essentially unchanged, but a new acceptor band has appeared just above the valency band. This acceptor band can accept electrons from the valency band and leaves holes in the latter which greatly increases the conductivity.

It should be noted that boron is only

one example of an acceptor type of impurity atom which produces *p*-type material; another example is indium. Similarly, arsenic is one example of a donor impurity atom which produces *n*-type material; others are antimony and phosphorus.

### CARRIER RECOMBINATION

When electrons and holes meet in a semiconductor material, the electron normally fills the hole. Thus electrons and holes are continually being removed as fast as they are created by thermal or other energy.

If a semiconductor material contains both *p*- and *n*-type impurities, the two types produce opposite effects and more or less neutralise one another. If there are more *p*-type impurity atoms than *n*-type, the material will be *n*-type.

In a *p*-type material the number of free electrons will be far less than in the pure intrinsic material. This is because there are a large number of holes in *p*-type

material and any electron moving through the material will probably combine with a hole very quickly and be removed.

Similarly, in *n*-type material the number of free electrons is large, so any hole moving through the material will quickly be removed as it meets one of the electrons. The product of the hole and the electron concentration is constant for a given semiconductor material at a given temperature, no matter what impurities are present provided that the impurity concentration is small.

### SEMICONDUCTOR JUNCTIONS

A semiconductor junction device may be made by employing *p*-type material on one side of the junction and *n*-type material on the other side. However, this type of junction must be fabricated as a single crystal—it is quite useless bringing a piece of *n*-type and a piece of *p*-type material together.

As soon as a *pn* junction is formed, holes from the *p*-type material and electrons from the *n*-type material diffuse across the junction. The electrons from the *n*-type material fill some of the holes in the *p*-type near the junction, whilst the holes from the *p*-type combine with some of the electrons in the *n*-type.

This flow of charge results in the type of picture shown in Fig. 5.5. The passage of positive charges to the *n*-type and negative charges to the *p*-type, results in the *n*-type material having a positive potential with respect to the *p*-type material.

### JUNCTION POTENTIAL

There is therefore a potential across the semiconductor junction. Any more positive holes from the *p*-type material which tend to approach the junction are repelled away from the junction region by the positive charge of the *n*-type. Similarly, any electrons in the *n*-type moving towards the junction are repelled back in the *n*-type region by the negative charge of the *p*-type.

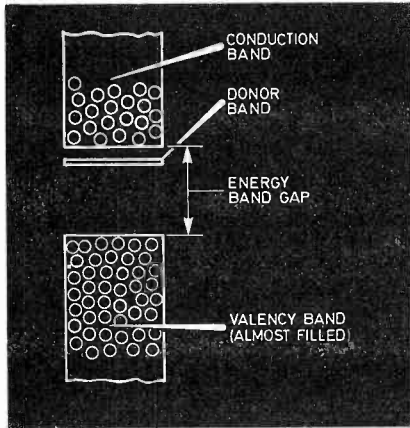

Fig. 5.2. Energy band diagram of an *n*-type semiconductor material.

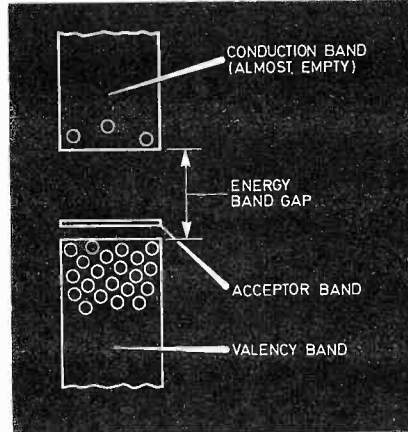

Fig. 5.4. Energy band diagram of a *p*-type semiconductor material.

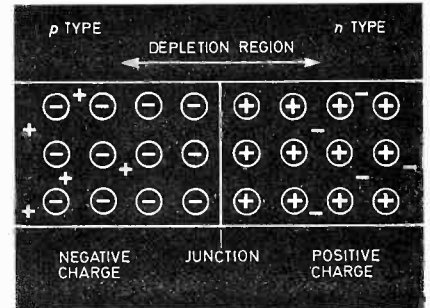

Fig. 5.5. A *pn* semiconductor junction. The charges shown encircled are fixed in position by chemical bonds, whilst the others are free to move.

Fig. 5.1. A silicon lattice containing an *n*-type impurity atom.

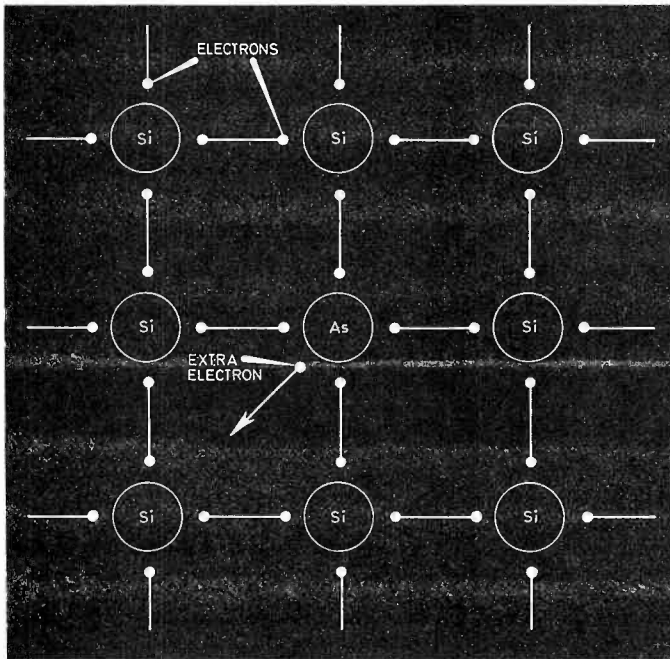
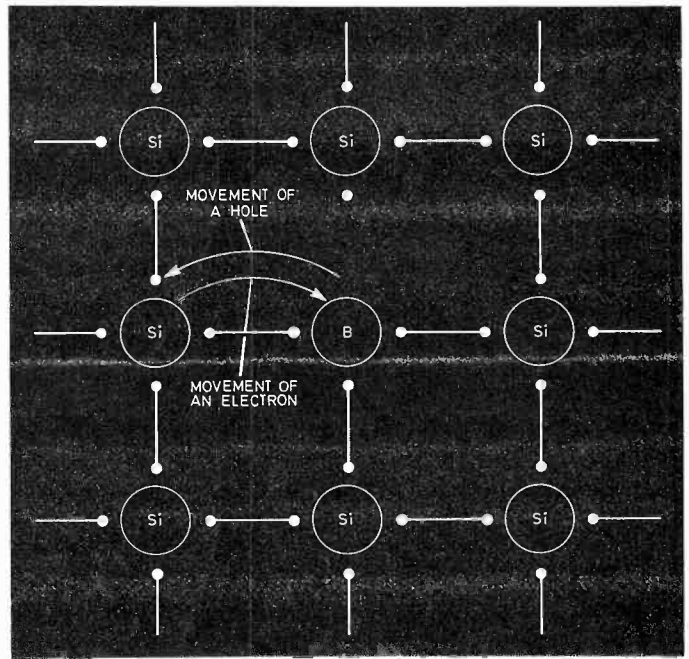

Fig. 5.3. A silicon lattice containing a *p*-type impurity atom.



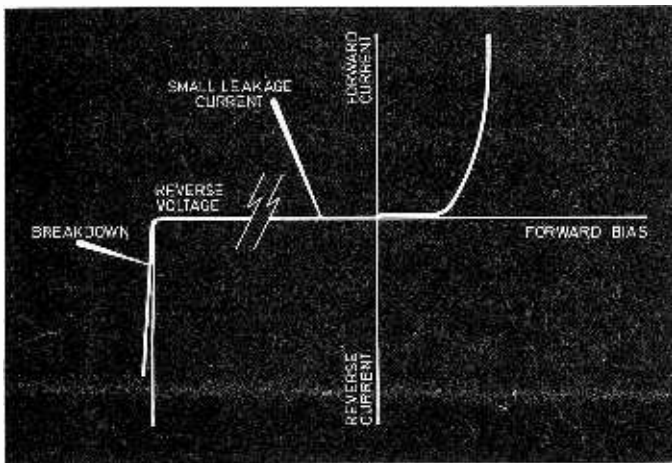

Fig. 5.6. Semiconductor junction diode characteristic showing the rapid increase of forward current with forward voltage. The reverse breakdown can be made to occur at quite high voltage.

There is therefore a region on each side of the junction which is depleted of charge carriers; this is known as the depletion region.

### RECTIFICATION

If a potential is applied across the *pn* junction of Fig. 5.5 so that the *p*-type material is made more negative and the *n*-type more positive, the electrons in the *n*-type material and the holes in the *p*-type material will be repelled even further from the junction so that the depletion region is increased in depth.

As no charge carriers are present in the junction region when a voltage of this polarity is applied, no current can flow and the diode is biased in the reverse direction. Actually a very small current (known as the leakage current) flows, since the *n*-type material does contain a

very low concentration of holes whilst the *p*-type material contains a small concentration of electrons.

The increase in the depth of the depletion region with reverse bias, results in a decrease in the capacitance across the junction, since the depletion region acts as an insulating region between the *p*-type and *n*-type materials, whilst these materials act as the plates of a capacitor. Thus a reverse biased junction diode can be used as a semiconductor variable capacitor the value of which is controlled by the applied reverse bias.

### FORWARD BIASING

If, however, a voltage is applied to the junction diode in the other direction, that is with the *p*-type positive and the *n*-type negative, a different type of behaviour can be observed. The electrons in the *n*-

type material are attracted towards the junction and the holes in the *p*-type material are attracted towards the junction also.

If the applied forward bias is not great enough to overcome the natural junction potential of the unbiased diode (about 0.55V in silicon) the diode will not conduct. When the forward voltage exceeds this value, however, the charge carriers are attracted across the junction and a forward current flows. The size of this forward current increases very rapidly with increasing voltage as shown in Fig. 5.6.

It can be seen that the reverse current remains very low until the junction undergoes breakdown, after which the reverse current rises very rapidly with voltage.

The small reverse current which flows before the breakdown voltage is reached is due to minority carriers (that is electrons in the *p*-type and holes in the *n*-type). The concentration of these charge carriers increases rapidly with temperature and therefore the leakage current also increases rapidly with temperature. The leakage current is much smaller in silicon than in germanium diodes owing to the larger energy band gap.

### OTHER DEVICES

Semiconductor junctions are present in almost all semiconductor devices. For example, two junctions are present in junction transistors (either *npn* or *pnp*), so many of the principles we have discussed can be applied to junction transistors. □

# CIRCUIT EXCHANGE

## AUTO WATER FEEDER

FEEDING water to plants can be automatically done using the circuit shown. When the soil moisture level falls

to a pre-determined value, determined by R1, the relay RLA is turned on. The relay can be used to fire an alarm or activate an electrically-operated valve, which feeds water to the plant.

The probes are two thick wires or rods 120mm long, the upper ends of which are fixed to a piece of non-conducting board of suitable size (say, 40 × 20mm). The rods should be straight and parallel with a separation of 15mm from each other.

J. Sreekumar,  
Cochin,  
India.

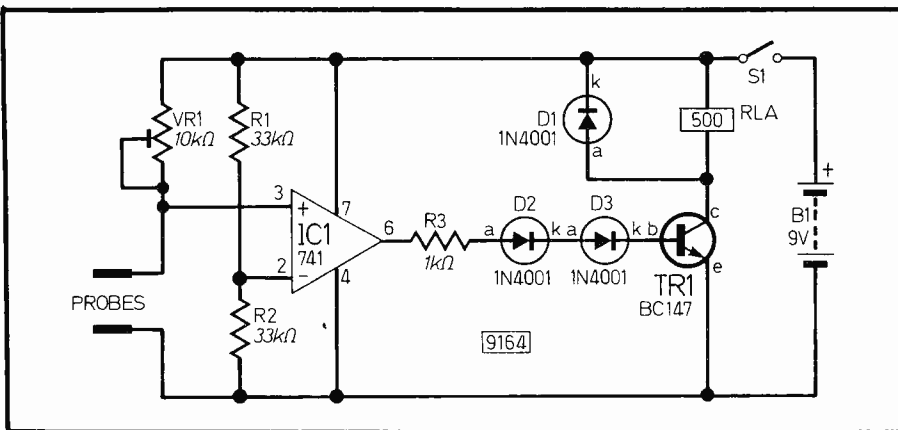

# PRACTICAL ELECTRONICS

## PROJECTS

- Computer Memory Error Correction Board
- 555/741 Tester
- Guitar Active Tone Controls
- Ground Communication System
- Logic Analyser Part 2

## Plus

- UK Satellite TV System Explained
- Microfile looks at the Z8000

and all the regulars including **BAZAAR** (free readers' advertisements), **SPACEWATCH**, **INGENUITY UNLIMITED**

**ON SALE NOW**

**MORE ON PAGE 611**



# FOR YOUR ENTERTAINMENT

BY BARRY FOX

## Video Facts

Sound is now becoming a major selling point in video. But much of what is written, and advertised, glosses over important facts. Here's what you should know if you are buying or renting a new video recorder and want good sound.

As I've previously explained, it's well nigh impossible to get genuine hi fi stereo sound from a domestic video cassette recorder. The stereo tape tracks are so narrow (around 0.25mm wide) and the tape speed so low (around 2.5cm/s, or half audio tape cassette speed) that it's a wonder that we can get anything at all.

The VHS manufacturers all use the Dolby B system, to improve signal-to-noise ratio. Some manufacturers, for instance National Panasonic, started to use the Dolby C system to cut tape hiss even further. But, unlike Dolby B, Dolby C isn't really compatible.

In other words although a Dolby B recording sounds reasonable when replayed on a machine without Dolby B circuitry, a Dolby C recording sounds distinctly odd. So Dolby C isn't finding favour.

Likewise the Sony Beta format noise reduction system, BNR or Beta Noise Reduction, isn't popular. It's more like DBX than Dolby, and thus cuts hiss quite dramatically. But like all powerful noise reduction systems, it can sometimes be heard breathing or pumping. Background hiss comes and goes with pulsating speech or sound.

It's a great pity that the Beta manufacturers, for political rather than technical reasons, wouldn't use Dolby. The inadequacy of BNR is why it's still difficult to get pre-recorded Beta video tapes with stereo sound.

Some of the software companies have been so unhappy with BNR that they've held back on Beta stereo releases. Thorn-EMI, for instance, took a decision to delay on Beta stereo releasing even though the company's catalogues had already been printed to advertise some films as available in Beta stereo.

Secretly the software companies are banking on the British launch of Beta hi fi. This system, now on sale in the US, puts genuine hi fi stereo sound into the video waveform as an f.m. signal. Expect a Beta hi fi launch in Europe later this year, or early next year, when it will give a shot in the arm to the Beta system.

## Double Take

Meanwhile the VHS manufacturers have launched two-speed machines. These can run the tape at half speed to double the recording and playing time available from a single cassette.

This means that a VHS recorder can now offer up to eight hours continuous playing time from a single, standard VHS cassette. This move is, of course, meant to compete with the V2000 format, which offers up to eight hours from a single cassette, but with the need to flip it over halfway through like an audio cassette.

The half speed machine is cleverly designed. You only need to switch the speed when you are recording, and you can do so even halfway through a programme. On replay the machine senses the speed at which the tape was recorded, and automatically switches replay speed accordingly.

There's just a short break up of the picture on screen. The snag of course is that because tape speed is halved, to around one quarter the speed of audio cassette tape speed, sound quality is very poor.

## Simulcasts

Anyone buying a stereo machine will eventually want to tape simulcasts with it.

## Teleprompting

If you thought that some politicians at the last election hustings were unusually sincere and eloquent, there's something you should know. There's a gadget, made by an American company called Q-TV, which lets a public speaker look an audience straight in the eye, while reading from a script displayed on a television screen.

The system is invisible unless you know how to spot it. Watch out for the plain glass sheet that's in front of Prime Minister Margaret Thatcher next time you see her eloquently talking into the middle distance. Actually, it's a two-way mirror that lets the audience see her, while she reads text from a video screen.

Teleprompting is an old idea. Actors have found that it's often impossible to learn a script in the short time available for a TV performance. In the early days, the words were written on idiot boards, large notices propped up around the studio.

Some actors depended entirely on this kind of help. If you remember the old Tony Hancock programmes, you may also remember seeing his eyes wander round the set until they fell on the nearest prompt board.

Then came Autocue, a clever system that lets an actor look straight at the camera, while reading a script. Peter Dimmock of the BBC was experimenting with it 30 years ago, but a commercial system was slow to arrive.

Before transmission the script is typed or written on a long roll of anti-glare paper. In a corner of the studio, or hidden back room, the paper is unrolled in front of a video camera, and this camera output fed to a TV monitor underneath the studio camera. This is shooting through a two-way mirror angled so that it sees only the scene to be televised, but an actor looking at the camera sees only a reflected image of the prompt screen.

Now, all television studios rely heavily on Autocue systems. Although actors still learn their words for drama productions, the announcers and link men and women you see on news and current affairs programmes are

Because we have no stereo sound with television in Britain, and are unlikely to have it for several years, the TV stations sometimes team up with f.m. radio stations to transmit separate stereo sound and pictures.

You can record a stereo video tape of a simulcast by feeding the sound in from a stereo hi fi system while taping the picture off-air through the video recorder's own tuner. But to do this easily you need a simulcast switch, which temporarily disconnects the mono sound tuner inside the video recorder.

The VHS stereo machines sold by JVC and Ferguson have this feature, but others don't. For instance, to tape simulcasts with the Sony C9 Beta stereo recorder or the Grundig V2000 stereo recorder you need to plug and unplug extra wires before and after each recording. This is a clumsy approach, especially on the Grundig machine, where the plugs are on the rear of the machine.

Philips promise a V2000 stereo recorder late this year with a simulcast switch. It's coming late on the market because the Philips factory is having to make special models for Britain with this feature.

almost always reading their words from an Autocue screen on the camera.

Once in a while the Autocue goes wrong, for instance the roll of text jams, or the operator runs it through at the wrong speed, or there's a technical failure. That's when you'll see a look of panic in the link person's eye, while they switch to ad-libbing or try to read from a script on the desk in front of them.

## Audience Contact

The Q-TV system was developed to give business speakers and politicians the equivalent of Autocue, but at public meetings where there's no life-saving TV camera with Autocue to gaze at. The script, or often just a list of crucial statistics and facts, is again typed on anti-glare paper, in an ordinary typewriter or word processor.

Behind the scenes the speaker's assistant moves from page to page to suit what's being said out front, while a closed circuit TV camera displays an image of the text pages on a TV monitor hidden underneath the speaker's table. This screen image is reflected up by a two-way mirror which is set at an angle in front of the speaker's eyes.

If the audience sees anything, it's just a plain glass plate a few feet in front of the politician's eyes. But the politician sees the prepared text running through on a television screen. So he or she can pretend to look straight at the audience, while quite literally pulling facts and figures out of the air.

The Q-TV system was developed in America, because over there they learned early about the need to simulate eye-to-eye contact with an audience. It's now used by firms like 3M, RCA, Con Edison, General Motors and Ford, to help their public speakers look more sincere.

President Reagan uses one and that's how Margaret Thatcher found out about the idea. Now an enterprising British firm is importing the system for any politician over here who sincerely wants to look sincere.

# MICROCOMPUTER INTERFACING TECHNIQUES

INCLUDING MANY USEFUL CONSTRUCTIONAL PROJECTS  
PART THREE: ANALOGUE-TO-DIGITAL CONVERSION

BY J. ADAMS B.Sc., M.Sc. & G.M. FEATHER B.Sc.

PHYSICAL quantities in the world outside the microcomputer are generally analogue in nature; that is, they vary in a continuous way. In the previous article electrical signals representing analogue quantities, such as light intensity, have been recognised by the microcomputer when the particular value achieves some predetermined threshold level.

If the actual magnitude of such a quantity is to be "logged" by a microcomputer then the analogue electrical signal developed by a transducer is often conditioned before being converted into a digital form which the microcomputer can accept. This is illustrated in Fig. 3.1.

## TRANSDUCER

The transducer senses the magnitude of the quantity to be measured and produces a corresponding analogue electrical representation.

As an example, a temperature sensing device could be employed which produces a 0 to 1V output voltage which varies with temperature over a temperature range of say 0 to 100 degrees Celsius.

## SIGNAL CONDITIONING

The analogue signal obtained from the transducer will convey the signal's information content but it may require amplification before it can be presented to an analogue-to-digital converter.

Signal conditioning circuits, often employing operational amplifiers, are generally present in data acquisition systems.

## ANALOGUE-TO-DIGITAL CONVERTER

An analogue-to-digital converter (ADC) is a device which will convert a suitable analogue input into a corresponding digital output code.

## SUCCESSIVE APPROXIMATION CONVERTERS

Various techniques exist for the conversion of the analogue signal obtained from a suitable transducer/conditioning circuit into a digital form which can be recognised by a microcomputer.

The successive approximation ADC offers one of the best combinations of ease of application and economy allied with speed of conversion and resolution.

The technique resembles, in some respects, the way in which many physical quantities are measured—by trial and error.

This analogy can be employed to give some understanding of the working of a successive approximation ADC.

Consider the determination of an unknown mass by comparison with known

masses using a beam balance as shown in Fig. 3.2.

When the trial masses equal the unknown mass, the pointer will be at zero deflection. The trial masses are arranged to be related by powers of 2:  $M/2$ ,  $M/4$ ,  $M/8$ ,  $M/16$ , and so on.

Measurement is started by placing the largest trial mass on the left-hand pan; if  $M_x > M/2$ , the pointer moves towards the right and the result of this test determines whether we increase the trial mass or make another trial with the next smallest mass. In the successive approximation ADC, the test is made with a trial voltage (developed from an accurate fixed reference voltage) and the result will set a bit in a register to logic 0 or 1, depending on the result.

The trial process is continued until the scale is balanced, each decision setting a less significant bit in the register to a 0 or 1, so building up the digital representation of the analogue quantity.

Converters offering resolution to 6, 8, 10 and 12 bits are available but 8-bit devices offer a satisfactory compromise between resolution and conversion time (the Ferranti ZN448 can perform more than 110,000 conversions per second with a resolution of 1 part in 256, or about 0.4 per cent).

All internal operations of the ADC are run sequentially by the system clock

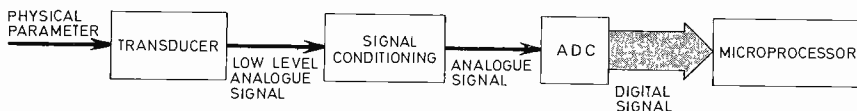

Fig. 3.1. Analogue-to-Digital Converter (ADC) and data acquisition.

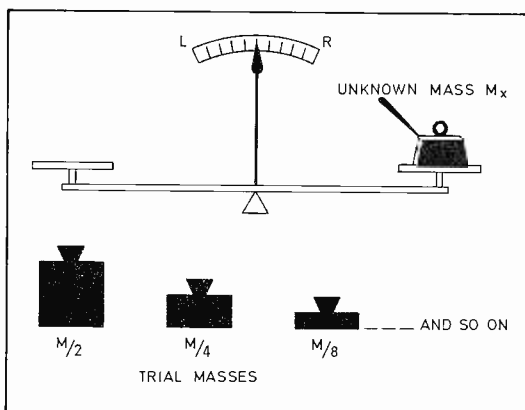

Fig. 3.2. Successive approximation balance analogy.

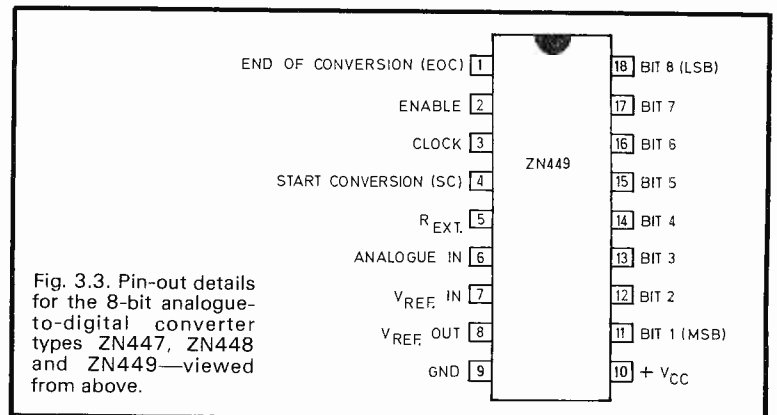

Fig. 3.3. Pin-out details for the 8-bit analogue-to-digital converter types ZN447, ZN448 and ZN449—viewed from above.

which hence determines the overall conversion time. A complete conversion occupies nine clock cycles so, for example, a ZN448 running at a clock frequency of 900kHz will give a conversion time of 10 $\mu$ s and therefore a conversion rate of 100,000s<sup>-1</sup>.

### OPERATING PROTOCOL

To use any type of ADC, a precise sequence of operations must be adhered to. A simplified description of this is given below for the successive approximation type.

#### STEP 1 START CONVERSION

An output pulse from the microcomputer instructs the ADC to initiate a conversion. (This arrangement is sometimes referred to as "convert on command".)

#### STEP 2 END OF CONVERSION

An output signal from the ADC instructs the microcomputer that the conversion has been completed.

The digital representation of the analogue quantity is, at this moment, stored in the output latches of the ADC, but the actual output lines are, in many converters, tri-state configured. That is, unless instructed to do so, the ADC will not output the digital information on to its output lines—they will remain in a high impedance state, effectively disconnected from the microcomputer so as not to interfere with other signals which might be present on these lines.

This is important when the lines are required for other purposes such as channel multiplexing, software control of signal conditioning amplifier gain, and so on.

#### STEP 3 ENABLE TRI-STATE

An output signal from the microcomputer instructs the ADC to make available at its output lines, the data present in its output latches.

The microprocessor is now in a position to read the binary code presented by the ADC.

#### STEP 4 DISABLE TRI-STATE

The enable output signal from the microcomputer reverts to its original state, sending the bus lines to a high impedance state. The cycle is now complete and the ADC awaits the next start conversion pulse before repeating the sequence.

### HIGH SPEED SINGLE CHANNEL BIPOLAR CONVERTER

The ADC employed in this project is a successive approximation Ferranti ZN449 device in a standard 18-pin d.i.l. package as shown in Fig. 3.3. The 8-bit binary code presented by the ADC to the microcomputer will hence allow the resolution of an input analogue voltage in 256 discrete steps. This "8-bit" resolution is simply the number of bit outputs that the ZN449 possesses and implies nothing about the accuracy of the device.

The device offers a fast conversion rate (up to approximately 110,000 conversions per second), an on-chip clock and reference voltage, tri-state outputs and +1 l.s.b. resolution.

Conversion time lasts for nine clock cycles giving the same maximum conversion rate as that for the ZN448.

### CIRCUIT DESCRIPTION FOR BIPOLAR OPERATION

The complete circuit diagram of the High Speed Analogue-to-Digital Converter is shown in Fig. 3.4.

The A-D device, IC2, requires, in addition to the usual +5V supply, a negative rail which in the circuit given, stands at about -3.5V. This could, of course, be derived from a second battery but in the circuit, Fig. 3.4, uses IC1 as a simple multivibrator, the output of which is rectified and smoothed by the D1, D2, C2, C3 network; this provides the necessary negative supply.

ADCs may be wired to give either "unipolar" or "bipolar" operation. In the unipolar case, only positive input voltages (that is, those which make  $V_{IN}$  positive with respect to ground) will produce a digital output. The design used in the project employs the bipolar technique in which the input voltage is offset by  $+V_{REF/2}$  so that the voltage at the input to the device itself will always be positive, even when  $V_{IN}$  goes down to  $-V_{REF/2}$ . The offset voltage is derived from  $+V_{REF}$  by the resistor network R1, R2, and VR2.

Bipolar operation is useful in that it allows the converter to sample values of an alternating voltage. As both positive and negative voltage ranges are encountered it is necessary to provide a method of digital coding to represent this. The coding most widely employed is referred to as "offset" binary. The line connected to the m.s.b.—the line with the greatest "weighting"—is used to indicate the sign of the voltage. When the m.s.b. (bit 7) is set and the line goes high then the input

Fig. 3.4. Circuit diagram of a single-channel high speed Analogue-to-Digital Converter (ADC).

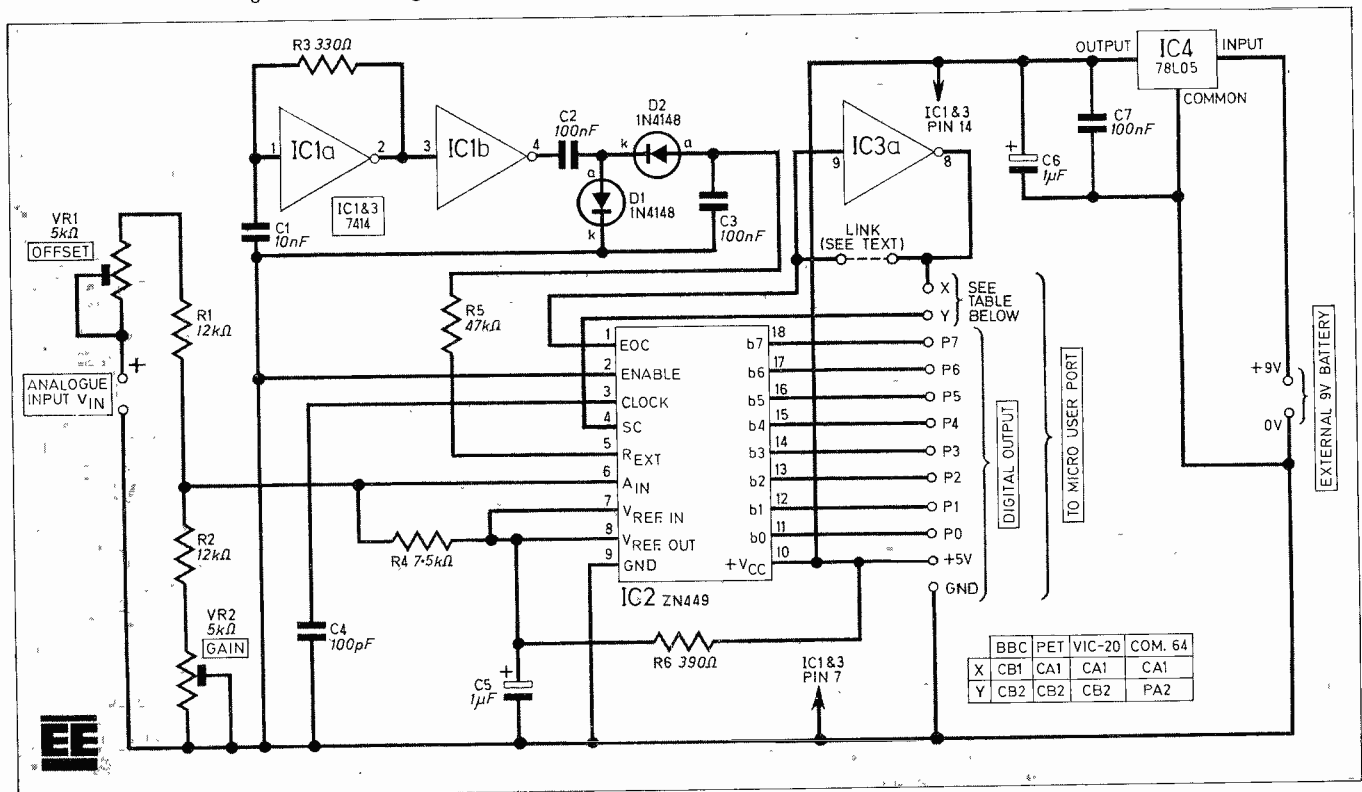

voltage to the ADC is positive, whereas if the m.s.b. is clear and the line goes low then the input voltage is negative.

Table 3.1 below indicates the logic coding for bipolar operation.

VR1 and VR2 provide for adjustment of the output for inputs of plus and minus

Table 3.1

Analogue Input	Digital Output
+(FS - 1 l.s.b.)	11111111
+(FS - 2 l.s.b.)	11111110
+1/2 FS	11000000
+ 1 l.s.b.	10000001
0	10000000
-1 l.s.b.	01111111
-1/2 FS	01000000
-(FS - 1 l.s.b.)	00000001
-FS	00000000

FS = Full Scale.

(±) full scale. A detailed description of the setting-up procedure is given. The resistor values given produce an analogue input voltage range of -5V to +5V.

In the design, the eight data lines (which are connected to P0-P7) are used solely for the purpose of applying the output of the ADC to the user port and, although the ZN449 does have tri-state outputs, the tri-state enable pin is kept at logic 0 (ground) so that the output latches are always enabled.

### READING CONVERTED DATA

During a conversion, invalid data will thus be present on the output lines and the microcomputer must not read the data available until the conversion is complete. When operating in Basic, this does not present a problem since the con-

version is completed well before the machine is ready, but for machine code operation it is necessary to employ the end of conversion (EOC) signal generated by the ADC to instruct the microcomputer to read the then valid data.

The EOC signal can be applied to the edge-sensitive handshake line as was discussed in the first article in this series. Readers should note that the Commodore 64 microcomputer requires a negative going edge-sensitive handshake and constructors intending to use this machine should include the inverter, IC3, in the EOC line. For the other machines, the LINK should be included and IC3 should not be fitted.

IC4 is a 78L05 5V regulator and need only be fitted if a 5V supply is not available at the user port. In this case, an external 9V supply for the board may be used; a PP9 battery will allow many hours of operation.

# HIGH SPEED ANALOGUE-TO-DIGITAL CONVERTER BOARD CONSTRUCTION

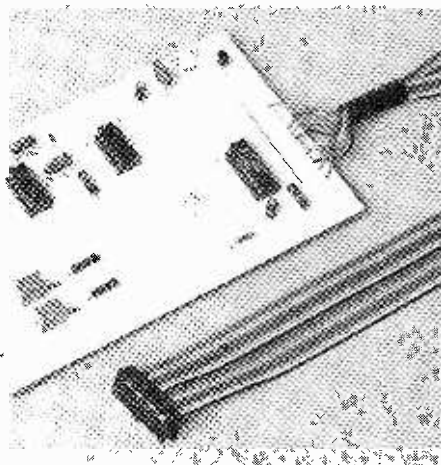

## CONSTRUCTION OF ADC

All the components are accommodated on a single-sided printed circuit board, size 150 x 95mm. The full-size master p.c.b. pattern to be etched is shown in Fig. 3.5. This p.c.b. is available through the *EE PCB Service*, Order code 8309-01; see page 565 for further details.

The layout of the components on the topside of the board is shown in Fig. 3.6. The 12 leads from the board to the user port connector are soldered directly to underdrilled oval areas on the track pattern after feeding through 1.3mm diameter holes near to the board edge. This acts as a strain relief mechanism for the soldered connection.

Begin assembly by soldering in the i.c. sockets, followed by the link wire, Veropins, resistors, presets, capacitors and finally the semiconductors. Pay attention to the orientation of IC4, the two diodes and the electrolytic capacitors.

The p.c.b. has been designed to be used with the BBC Micro, PET, VIC-20 and Commodore 64 computers. The latter requires a negative going edge-sensitive

handshake. This is provided by the inverter in IC3. This i.c. should not be inserted if the board is to be used with the other three machines, but a link wire must be fitted between IC3 socket positions 8 and 9. This is the "dotted" link in Fig. 3.4.

There is no +5V supply rail available on the PET computer user port, but IC4 with C6 and C7 provide a suitable +5V supply for the on-board components when a 9V battery such as a PP9 is connected. These components may be omitted if building this project for any of the other computers mentioned above.

Finally, connect the user port cable to the p.c.b. according to Figs. 3.6 and 3.7.

## SETTING UP PROCEDURE

The ADC board should be connected to the microcomputer via ribbon cable and appropriate user port plug as shown in Fig. 3.7. If necessary, an external battery may be added.

The simple Basic program TEST, appropriate to the particular microcomputer, should now be loaded into the

microcomputer. When run, the screen will display a number in the range 0 to 255. (This is the decimal value of the 8-bit binary number at the outputs of the ADC.)

It is first necessary to apply -4.98V (-5V will do) to the analogue input and adjust the offset control VR1 until the display just flickers between 0 and 1.

The input connections should now be reversed and the gain control VR2 adjusted until the display flips between 254 and 255. The first step should now be repeated.

Finally, the analogue input terminals should be short-circuited, when the display should read 128. If this is not the case, then repeat the whole procedure.

## STORAGE OSCILLOSCOPE

With the very fast conversion rate offered by the ZN449 periodic waveforms of frequency up to a few kilohertz may be sampled several times per cycle and stored in immediate access memory (RAM) for subsequent display at a convenient time.

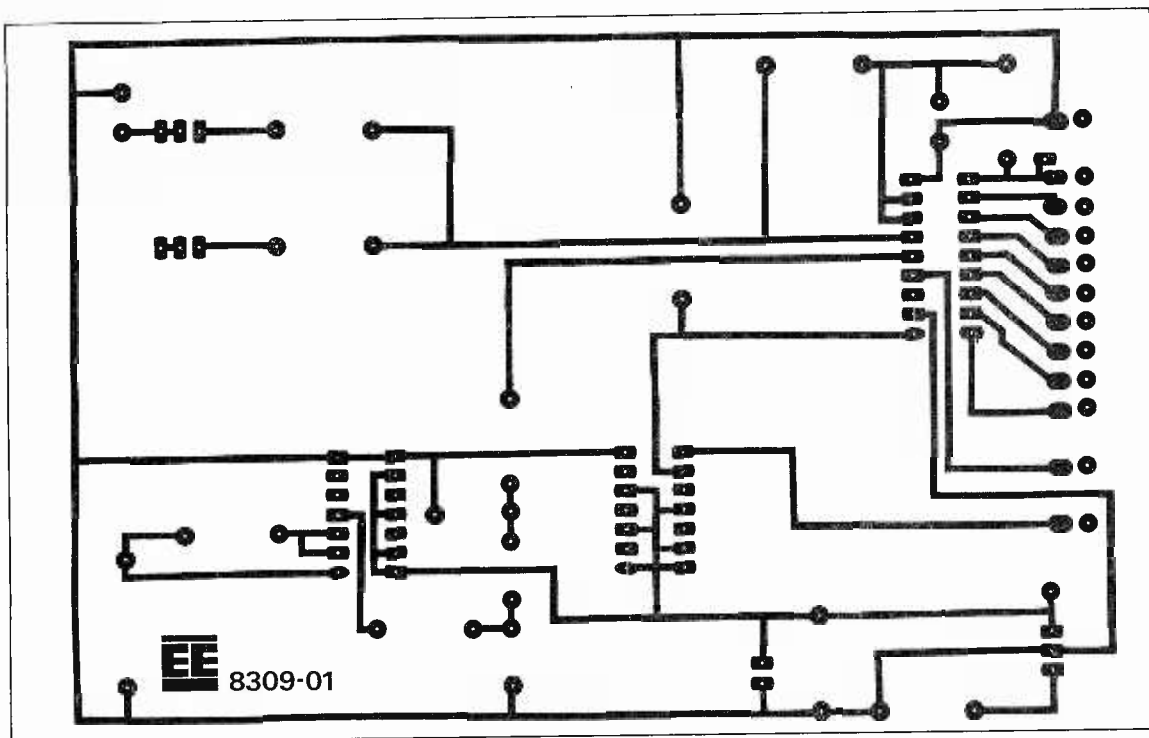

Fig. 3.5. Master pattern (actual size) to be etched for the ADC board. This board is available through the *EE PCB Service*, Order code 8309-01.

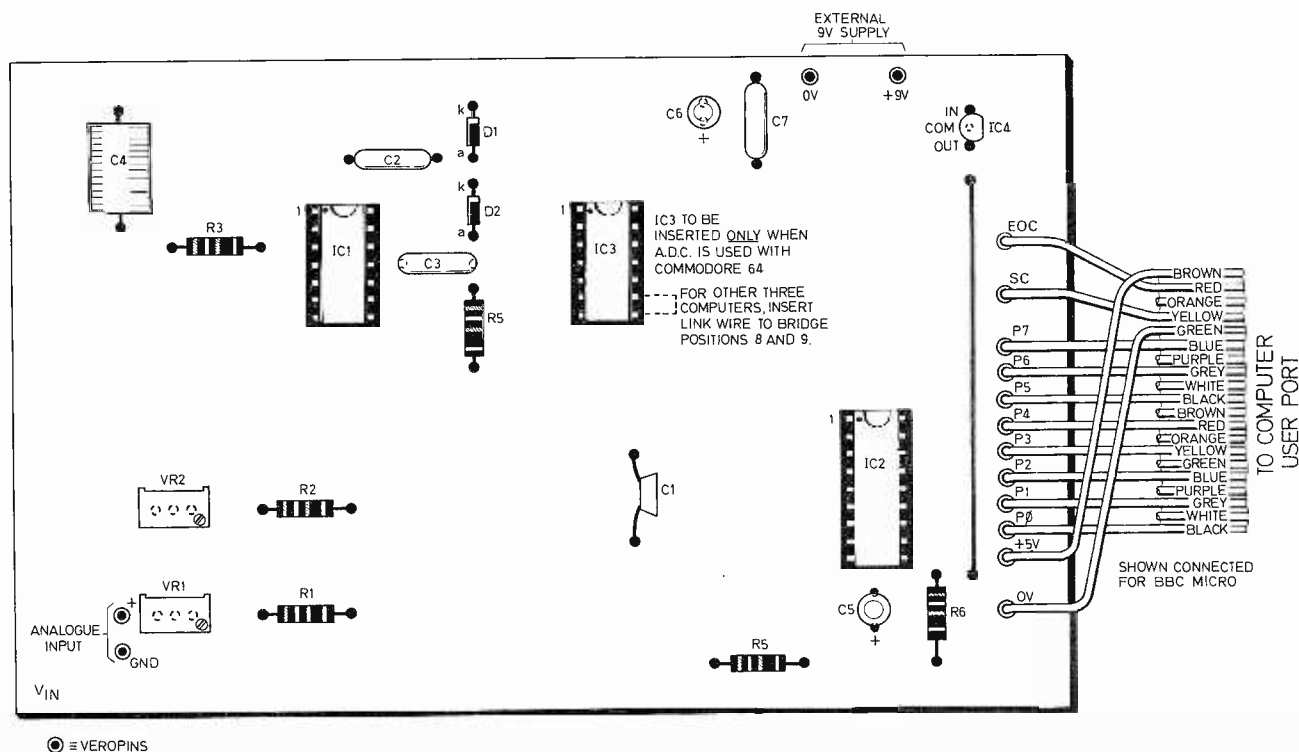

Fig. 3.6. Layout of the components on the topside of the p.c.b. with interconnection details to the user port connector.



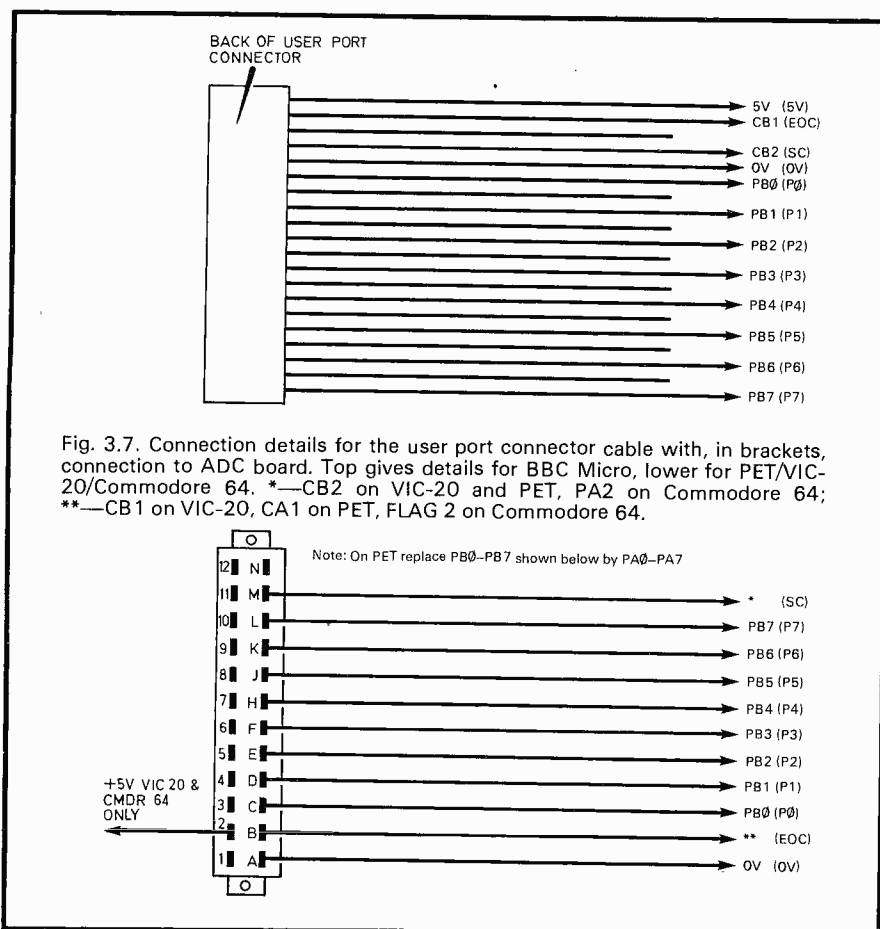

Fig. 3.7. Connection details for the user port connector cable with, in brackets, connection to ADC board. Top gives details for BBC Micro, lower for PET/VIC-20/Commodore 64. \*—CB2 on VIC-20 and PET, PA2 on Commodore 64; \*\*—CB1 on VIC-20, CA1 on PET, FLAG 2 on Commodore 64.

## ADC TEST ROUTINES

```
5 REM BBC TEST PROGRAM
10 ?65122=0
20 ?65132=?65132AND160
30 ?65120=0
40 PRINT ?65120
50 GOTO 30
```

```
5 REM PET TEST PROGRAM
10 POKE 59459,0
20 POKE 59468,PEEK(59468)OR192
30 POKE 59468,PEEK(59468)OR32
40 POKE 59468,PEEK(59468)AND223
50 POKE 59468,PEEK(59468)OR32
60 PRINT PEEK(59457)
70 GOTO 30
```

```
5 REM VIC-20 TEST PROGRAM
10 POKE 37138,0
20 POKE 37147,PEEK(37147)AND227
30 POKE 37148,PEEK(37148)OR192
40 POKE 37148,PEEK(37148)OR32
50 POKE 37148,PEEK(37148)AND223
60 POKE 37148,PEEK(37148)OR32
70 PRINT PEEK(37136)
80 GOTO 40
```

```
5 REM COMMODORE 64 TEST PROGRAM
10 POKE 56579,0
20 POKE 56578,PEEK(56578)OR4
30 POKE 56576,PEEK(56576)OR4
40 POKE 56576,PEEK(56576)AND251
50 POKE 56576,PEEK(56576)OR4
60 PRINT PEEK(56577)
70 GOTO 30
```

This opens up the attractive possibility of using the system as a relatively inexpensive storage oscilloscope. For this very fast application of the ADC, machine code software is essential, and normally involves incrementing an index register and storing perhaps 256 digitised points in contiguous memory locations using indexed addressing.

Even non-periodic waveforms, such as one-shot impulses, can be sampled at great speed if the storage of results occurs only when the analogue signal exceeds a "trigger" level.

One very interesting arrangement is to connect a high output crystal/ceramic microphone to the ADC via the signal conditioning amplifier described in this article. Instantaneous values of a speech waveform can then be sampled and stored before being displayed either on a VDU or printer.

Further use of this board, including another constructional project for fast data logging, will be dealt with later in this series. Software will be available through the *EE Software Service* for those wishing to implement machine code software with their ADC board.

## COMPONENTS

### Resistors

R1,2	12k $\Omega$
R3	330 $\Omega$
R4	7.5k $\Omega$
R5	47k $\Omega$
R6	390 $\Omega$

All  $\frac{1}{4}$ W carbon  $\pm 5\%$

See  
**Shop  
Talk**

page 565

### Capacitors

C1	10nF
C2,3	100nF polyester type C280 (2 off)
C4	100pF ceramic plate
C5,6	1 $\mu$ F 6V elect.
C7	100nF polyester type C280

### Semiconductors

IC1	7414 TTL hex Schmitt inverter
IC2	ZN449, 448 or 447 8-bit analogue-to-digital converter
IC3	7414 TTL hex Schmitt inverter
IC4	78L05 100mA voltage regulator
D1,2	1N4148 small signal silicon

### Miscellaneous

VR1,2	5k $\Omega$ cermet multiturm preset ( $\frac{1}{8}$ inch square)
-------	--

**Printed circuit board:** single-sided size, 150 x 95mm, *EE PCB Service*, Order code 8309-01; 14-pin d.i.l. sockets (2 off); 16-pin d.i.l. socket; single-sided Veropins (4 off); self-adhesive rubber feet (4 off); ribbon cable and connector to suit computer used.

Approx. cost  
Guidance only **£13** excluding cable/connector

## SIMPLE EXPERIMENTS WITH THE ADC

### Joystick Potentiometer

The simple potentiometer circuit of Fig. 3.8 should be set up and the output connected to the analogue input terminals of the ADC. Rotation of the potentiometer spindle should cause the digital value displayed on the screen to vary over a range of approximately 25 to 230 corresponding to analogue inputs of  $-4.5$ V to  $+4.5$ V. It is left to the reader to devise a simple program in which this digital value of the analogue voltage can be used to control the y (or x) coordinate of a plotted point.

### Optical Intensity Measurement

The circuit of Fig. 3.9 employs an ORP12 light dependent resistor (l.d.r.) in a simple potential divider arrangement. When fully illuminated, the resistance of the l.d.r. falls to a value of about 100 ohms; the output voltage from the potentiometer will then be approximately

equal to the supply voltage, 4.5V. When dark the l.d.r. resistance increases to approximately 100kΩ, thus decreasing the voltage across R1 to almost zero. As this transducer provides a positive analogue input to the ADC the digital output representation is limited to the range 128 to 255, inclusively.

The output voltage and optical intensity are not related linearly, but if a photometer is available, the arrangement may be calibrated. The authors have employed this technique in colorimetric applications.

### Simple Temperature Measurement

In the temperature measurement application, a thermistor forms part of a potential divider arrangement, the positive output voltage of which depends upon the temperature of the thermistor. The circuit is shown in Fig. 3.10.

As with the previous case, the output voltage is not proportional to the temperature of the thermistor. A calibration curve, Fig. 3.11, is given for the particular type used, and can be held in immediate access memory (RAM) as a calibration table. The software solution to non-linearity involves searching the table until the largest input value corresponding to a particular temperature reading is found.

### SOFTWARE

The eight lines available at the user port must be configured for input if the microcomputer is to accept the eight bits of digital information from the ADC. This is achieved by clearing each bit in the data direction register for the port.

BBC Model B	VIC-20	PET	Comodore 64
765122=0	POKE37138,0	POKE59459,0	POKE56579,0

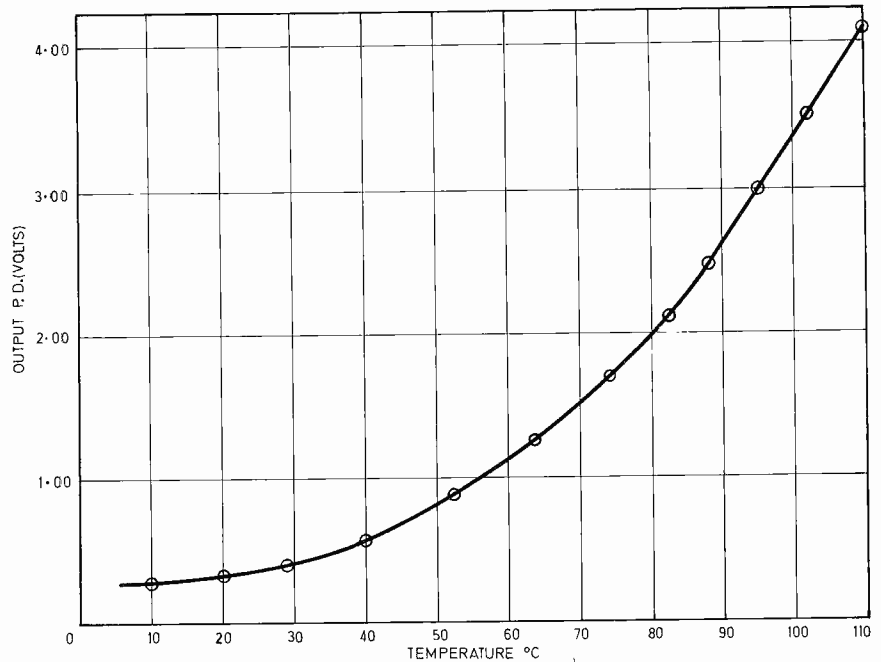
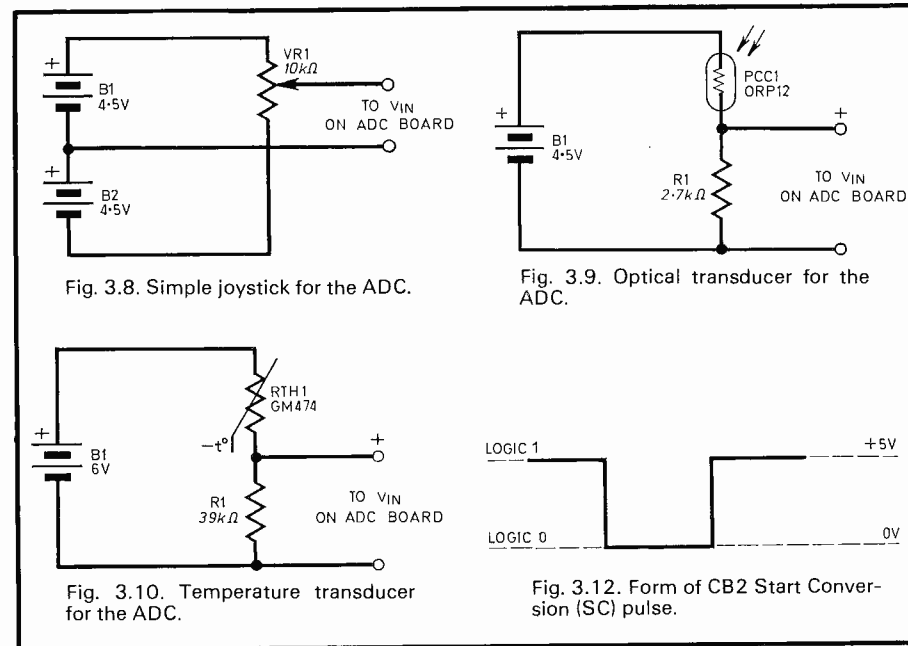

Fig. 3.11. A calibration curve constructed for the GM474 thermistor (29KO series).

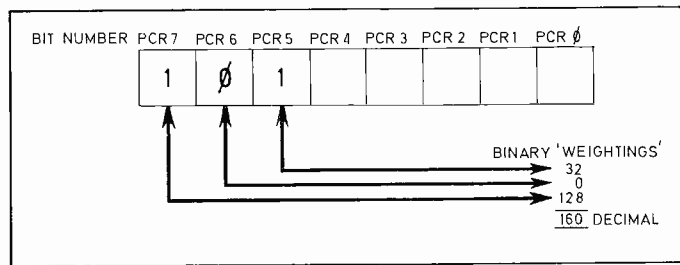

Fig. 3.13. The Peripheral Control Register (PCR) in pulse output mode. The three most significant bits control the mode of operation of the CB2 line.

The start conversion (SC) pulse, necessary to initiate the conversion process, can be obtained in a variety of ways but it is often appropriate to put the ADC entirely under microprocessor control and derive the pulse from an output line available at the microcomputer. The shape of the pulse necessary to start conversion for the ZN449 is illustrated in Fig. 3.12.

### BBC Model B Microcomputer

Pin 4 (CB2) at the user port can act as an output line under program control and is ideal for sending a start conversion pulse from the microcomputer to the ADC.

The simplest way that this may be accomplished is to set up the CB2 line in pulsed output mode. This line will then go low for one cycle if the I/O register for the port is written to.

This is a "dummy" operation as the port is configured to receive information from the ADC and the eight lines will not actually output data.

To allow the CB2 line to act in pulse output mode it is necessary to use another memory-mapped register within the 6522 VIA called the Peripheral Control Register (PCR). Three bits (PCR7, PCR6 and PCR5) are used to establish any one of the eight different modes of

operation of the CB2 line. In pulse output mode the bits are configured as shown in Fig. 3.13. Once this has been achieved by

```
?65132=?65132AND160
```

then any write to the I/O register, for example, ?65120=0 will send a one-shot negative pulse from pin 4 to the start conversion pin of the ADC and initiate conversion.

### PET

Pin M (CB2) at the user port can act in much the same way as the BBC Micro CB2 line. The three bits PCR7, PCR6, PCR5 in the Peripheral Control Register (PCR) are again used to characterise the mode of operation of the line. The register is located at memory address 59468. In this case two further modes of operation will be used to send the start conversion (SC) pulse to the ADC. Manual output mode is first selected by setting bits PCR7 and PCR6 in the PCR. This can be achieved as follows:

```
POKE59468,PEEK(59468)OR192
```

Note that the logical OR operator is used to ensure that only bits PCR7 and PCR6 are set. This must be done independently of the other bits in the register which are used for other purposes.

Once this mode has been selected, the CB2 line will reflect the state of bit PCR5, that is, if PCR5 is set then the CB2 line is held high, but if PCR5 is clear then the CB2 line is held low.

The following coding illustrates how a

start conversion pulse can be fashioned by manipulating the contents of the PCR with logical operations.

```
10 POKE59468,PEEK(59468)OR192:REM CB2 MANUAL OUTPUT MODE
20 POKE59468,PEEK(59468)OR32:REM CB2 HIGH
30 POKE59468,PEEK(59468)AND223:REM CB2 LOW
40 POKE59468,PEEK(59468)OR32:REM CB2 HIGH
```

### VIC-20

The start conversion pulse can again be derived from the CB2 line at pin M. The Peripheral Control Register is located at memory address 37148. For example:

```
10 POKE37147,PEEK(37147)AND227:REM DISABLE SHIFT REGISTER
20 POKE37148,PEEK(37148)OR192:REM CB2 MANUAL OUTPUT MODE
30 POKE37148,PEEK(37148)OR32:REM CB2 HIGH
40 POKE37148,PEEK(37148)AND223:REM CB2 LOW
50 POKE37148,PEEK(37148)OR32:REM CB2 HIGH
```

### COMMODORE 64

The Commodore 64 has no CB2 line available at the user port. Bit 3 of Port A (PA2) is, however, brought out at pin M. To configure this line for output it is necessary to set the corresponding bit in the Data Direction Register for the port located at memory address 56578.

The start conversion pulse can then be derived by setting, clearing and re-setting bit 3 in the I/O register for the port. This can be achieved as follows:

```
10 POKE56578,PEEK(56578)OR4:REM PA2 OUTPUT
20 POKE56576,PEEK(56576)OR4:REM PA2 HIGH
30 POKE56576,PEEK(56576)AND251:REM PA2 LOW
40 POKE56576,PEEK(56576)OR4:REM PA2 HIGH
```

## SIGNAL CONDITIONING AMPLIFIER

The electrical signals from some transducers may be too small to feed into A-to-D Converter circuitry to obtain satisfactory results. A simple signal conditioning amplifier which will give boost to the transducer signal by factors of  $\times 10$  and  $\times 100$  is shown in the circuit diagram of Fig. 3.14.

The circuit is based around a differential operational amplifier i.e., IC1, the much used 741. This is arranged in the "non-inverting" mode. R1 sets the input impedance at 75 kilohm. Negative feedback consists of R3 or R4 with R2 which sets the gain of the amplifier.

The gain is equal to:

$$\frac{R_2 + R_3}{R_2} \text{ with S1 in upper position}$$

$$\frac{R_2 + R_4}{R_2} \text{ with S1 in lower position}$$

Substituting in the given circuit values gives gains of 100 and 10, respectively (actually the gains are 101 and 10.1, but the rounded off figures are good enough ones to work with, bearing in mind the resistor tolerances).

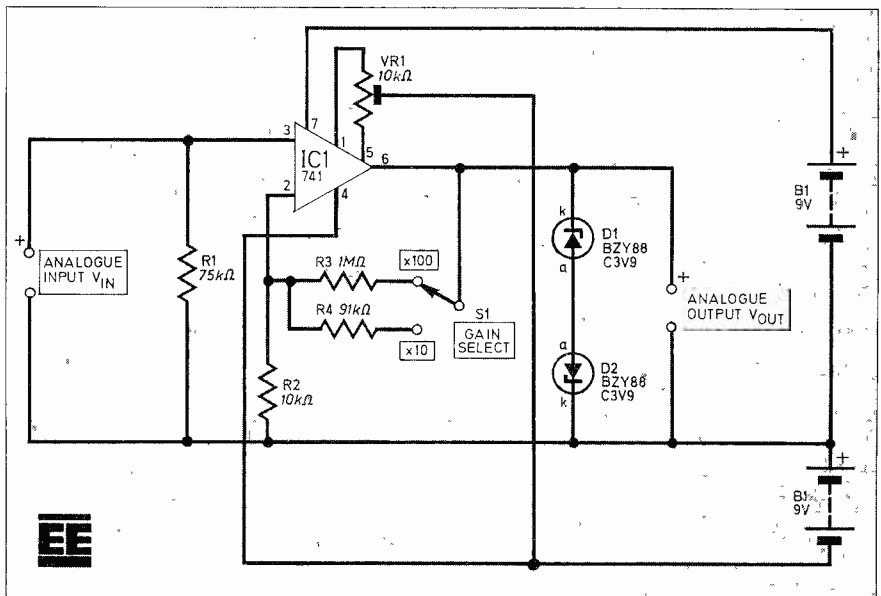

Fig. 3.14. The circuit diagram of a Signal Conditioning Amplifier for use with the ADC.

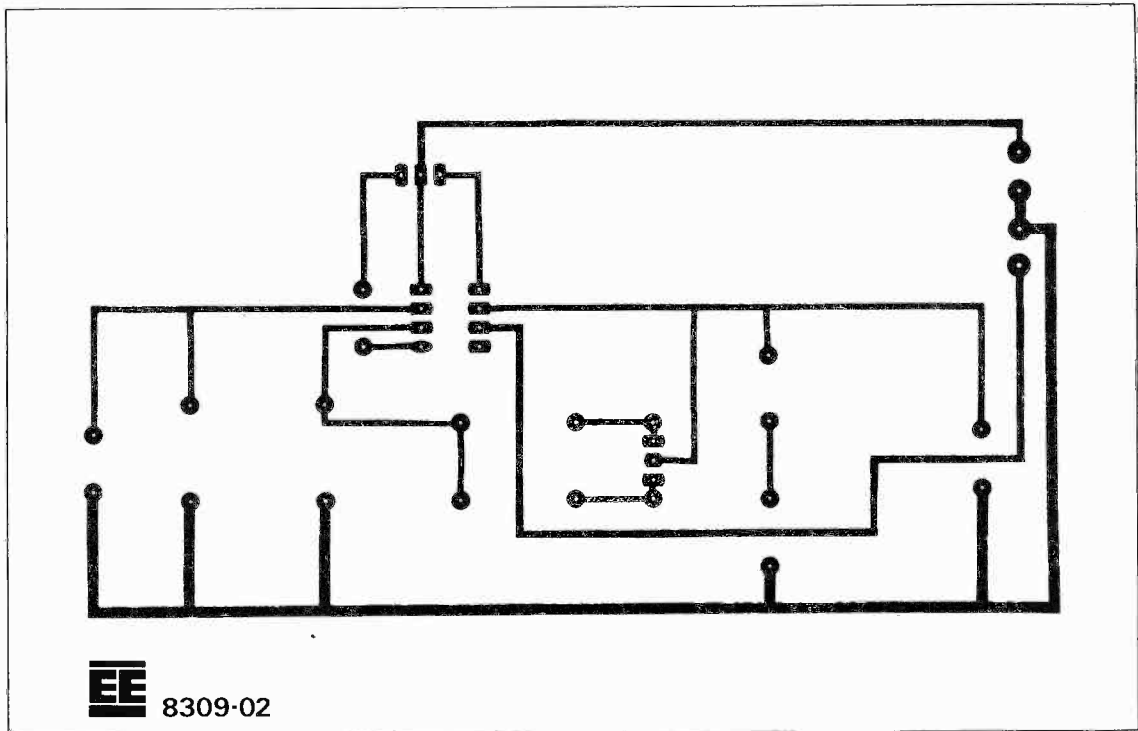

Fig. 3.15. Master pattern (actual size) to be etched for the Signal Conditioning Amplifier. This board is available through the *EE PCB Service*, Order code 8309-02.

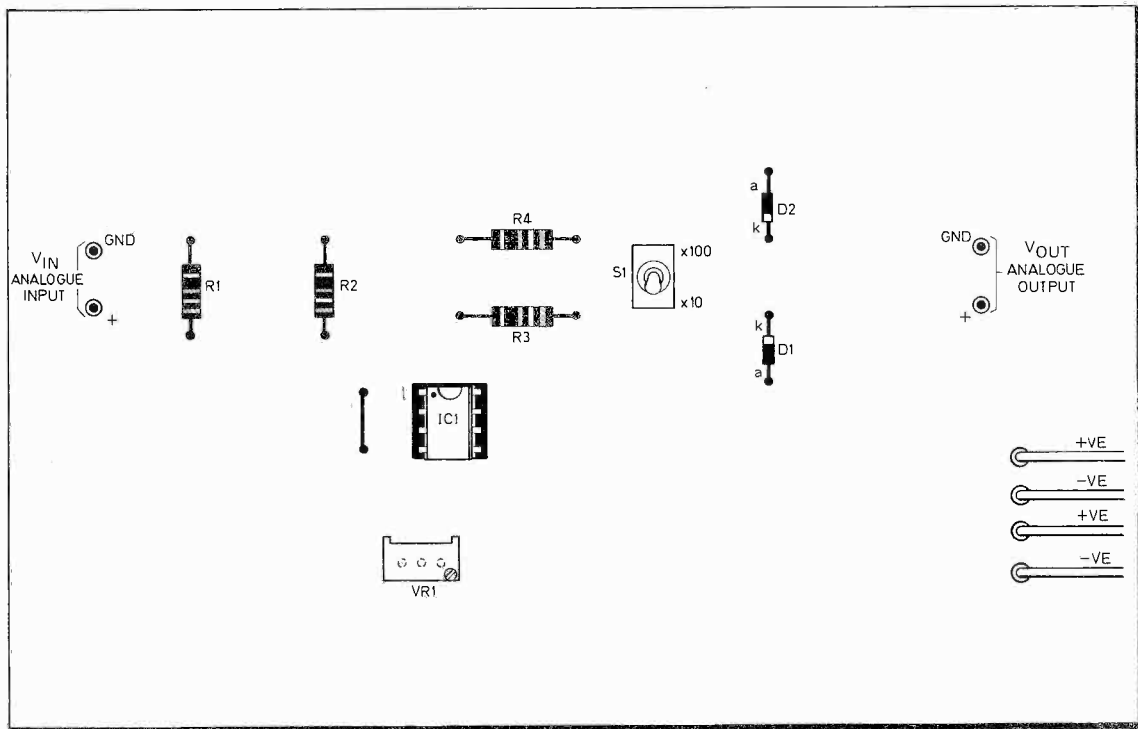

Fig. 3.16. The layout of the components on the topside of the printed circuit board.

## COMPONENTS

### Resistors

R1	75k $\Omega$
R2	10k $\Omega$
R3	1M $\Omega$
R4	91k $\Omega$
All $\frac{1}{4}$ W carbon $\pm 5\%$	

See  
**Shop  
Talk**  
page 565

### Semiconductors

D1,2	BZY88C3V9 3.9V 400mW Zener diode (2 off)
IC1	741 op-amp (8-pin d.i.l.)

### Miscellaneous

B1,2	9V type PP9 (2 off)
VR1	10k $\Omega$ cermet multiturn preset ( $\frac{3}{8}$ inch square)
S1	miniature s.p.d.t. p.c.b. mounting type

**Printed circuit board:** single-sided size, 125 x 95mm, *EE PCB Service*, Order code 8309-02; single-sided Veropins (4 off); PP9 battery clips (2 pairs); 7/0.2mm insulated wire for batteries; 8-pin d.i.l. socket; self-adhesive rubber feet (4 off).

Approx. cost  
Guidance only **£7.50**

The input signal is applied to the "+" input of IC1 and appears amplified at its output, pin 6, the amount of amplification determined by S1 position. Zener diodes D1 and D2 limit negative and positive excursions of the amplified signal to a safe level for inputting to the ADC board. The maximum output will be  $\pm 3.9$ V, the value of the Zener diodes.

The power supply for the circuit needs to be a split type ranging from  $\pm 6$ V to  $\pm 15$ V;  $\pm 9$ V was selected as this is readily available in battery form. Two PP9 batteries will give long service.

### CONSTRUCTION

The components are mounted on a single-sided printed circuit board, size 125 x 95mm; the full-size master pattern to be etched is shown in Fig. 3.15. This board is available through the *EE PCB Service*, Order code 8309-02.

The printed circuit board has been designed to accept a miniature p.c.b. mounting single-pole two-way toggle type having in-line pins. Two sets of fixing holes have been provided to allow switches with pins on a 0.1 and 0.2 inch pitch to be used.

Order of component assembly is unimportant. Check that the diodes are correctly orientated and that the i.c. is inserted the right way round in its socket. Component layout is shown in Fig. 3.16.

The power supply leads from the two batteries can be soldered directly to the board or via a p.c.b. screw terminal block as provision has been made for this connector to be fitted. This connection differs from that seen in the photograph which is fitted with three battery leads only.

Thoroughly check your assembly after plugging in the i.c. and when satisfied connect the two batteries and then short together the two input Veropins. Attach a voltmeter across  $V_{OUT}$  and adjust VR1 for zero deflection on the meter. Remove the shorting link and the unit is ready for use.

The sensor signal should connect to  $V_{IN}$  on the amplifier board with its  $V_{OUT}$  connected to the  $V_{IN}$  of the ADC board. Set S1 to the required gain so that the output signal is maximised without clipping (the Zener diodes are not activated). □

### Next month:

Digital-to-Analogue  
Techniques

# EVERYDAY ELECTRONICS SOFTWARE SERVICE

The EE Software Service provides an easy and reliable means of program entry for our computer-based projects. All programs have been tested by us and consist of two good quality copies of the working program on cassette tape. Certain program listings are also available.

All prices include VAT, postage and packing. Remittances should be sent to Everyday Electronics Software Service, Editorial Offices, King's Reach Tower, Stamford Street, London SE1 9LS. Cheques should be crossed and made payable to IPC Magazines Ltd.

PROJECT TITLE	CASSETTE CODE	CASSETTE COST	LISTING CODE	LISTING COST
ZX81 SPEED COMPUTING SYSTEM (Feb 83)	T001	£2.95	L001	£2.95
REAL-TIME CLOCK (Apple) (May 83)	T002	£2.95	L002	£2.95
REAL-TIME CLOCK (BBC) (May 83)	T003	£2.95	L003	£2.95
EPROM PROGRAMMER (TRS-80 & GENIE) (June 83)*	T004	£3.95	N/A	—
STORAGE SCOPE INTERFACE (BBC) (Aug 83)	T005	£2.95	—	—

\* Includes Command List with examples.





# OCTOBER FEATURES

## SPECIAL OFFER

EAGLE KEW 7S MULTIMETER AS  
USED IN THE TEACH-IN '84  
SERIES. HANDY 2000 OHMS/V  
INSTRUMENT. VALUABLE ASSET  
FOR ALL ENTHUSIASTS.

## TEACH-IN '84

A TWELVE-PART HOME STUDY COURSE IN THE PRINCIPLES AND PRACTICE OF ELECTRONIC CIRCUITS. ESSENTIALLY PRACTICAL, EACH PART INCLUDES EXPERIMENTS TO DEMONSTRATE AND PROVE THE THEORY. USE OF A PROPRIETARY BREADBOARD ELIMINATES NEED FOR SOLDERING AND MAKES ASSEMBLY OF CIRCUITS SIMPLE. THE IDEAL INTRODUCTION TO THE SUBJECT FOR NEWCOMERS. ALSO A USEFUL REFRESHER COURSE FOR OTHERS. KITS OF COMPONENTS FOR TEACH-IN '84 AVAILABLE FROM OUR REGULAR ADVERTISERS.



## ELECTRONIC PENDULUM



THIS YEAR'S SEDAC WINNING PROJECT. A VALUABLE CONTRIBUTION TO PHYSICS STUDIES. USED IN ASSOCIATION WITH BBC MICRO.

## HOME INTERCOM

Use of i.c. audio amplifier in main station unit provides good quality reproduction. Volume control. Call facility at remote station.

## IMMERSION HEATER TELL-TALE

An electronic aid for reducing energy costs. Feels the hot-water tank electronically at four levels and operates a corresponding display of l.e.d.s.

## SHORT WAVE RADIO

A simple t.r.f. circuit using ready-made coils covering 1.5MHz to 30MHz in three tuning ranges. Provides an inexpensive introduction to short-wave listening.

EVERYDAY  
**ELECTRONICS**  
and computer PROJECTS

OCTOBER 1983 ISSUE ON SALE FRIDAY, SEPTEMBER 16

## SEDAC '83 RESULTS

- \* FINAL SWINGS TO NOTTINGHAM
- \* NORFOLK ATTRACTS SECOND PRIZE
- \* LANCS TEAMWORK SECURES THIRD PRIZE

Excitement and tension was almost up to Final's Day on the Centre Court at the Second Schools Electronic Design Award Competition (SEDAC), sponsored jointly by Mullard Ltd., and EVERYDAY ELECTRONICS. The final judging and presentation of prizes took place in Mullard House, London, over two days—28 and 29 June.

Schools from the length and breadth of Britain took part in the second national contest to help encourage the technologists of the future put their ideas into reality.

The three winners were selected from twelve finalists whose models were on display at Mullard House. At the presentation on 29 June, Ivor Cohen, Managing Director of Mullard and Michael Paton, Managing Director of Youth & Practical Group, IPC Magazines, shared the honour of presenting prizes to the winning teams.

Opening his address at the prize-giving ceremony, Ivor Cohen made the point that "standards this year are so high that his technical judges were worried about their jobs!" This he observed was with some justification.

In his welcoming speech, Michael Paton also praised the high standard of papers and practical skills of ALL finalists.

However, he did voice his disappointment at the lack of "competitive spirit" shown by Girls' Schools—who failed to participate. This was despite special invitations going out to one hundred Girls' Schools throughout the country.

### JUDGING PANEL

Scrutiny of Papers (Stage 1) and evaluation of working models (Stage 2) was performed by a panel of four judges representing the two sponsoring parties. The panel members were:

Andy Beer	Technical Manager, Power Control Devices, Mullard Ltd.
Terry Giles	I.C. Product Specialist, Mullard Ltd.
Fred Bennett	Editor, <i>Everyday Electronics</i>
Brian Terrell	Assistant Editor, <i>Everyday Electronics</i>

The judges wish to record their admiration for the high standards throughout, both in the written work and in the practical realisation of the designs. All students participating deserve the highest commendation and were a credit to their schools.

## HIGHLY SUCCESSFUL SECOND YEAR FOR NATIONAL SCHOOLS CONTEST



The proud winner of the 1983 Schools Electronic Design Award Competition, Martin Cragg of Roland Green School, receiving the SEDAC Trophy from Michael Paton of IPC Magazines with Ivor Cohen of Mullard keeping a watchful eye on the proceedings.

### Winning Entries

The **first prize** of £300, the SEDAC Trophy and selection of components worth £200 were awarded to Martin Cragg (15), of Roland Green School, Welford, Nottingham, for his Electronic Pendulum.

**Second prize** of £200 plus components to the value of £200 was awarded to Robert Rowe (16), of Wymondham College, Norfolk, for his Digital Gauss Meter.

**Third prize** was won by Michael Lawrie (15) and Lorna Wilkinson (13), of Hollins High School for their Environmental Data Recorder.

The Remaining nine runners-up received component packs valued at £100. The runners-up were: Mill Hill School, London; Ousedale School, Newport Pagnell; Parkview School, Barrow-in-Furness; Princess Margaret Royal Free School, Windsor; Ridings High School, Winterbourne; Skegness Grammar School, Skegness; Skinners' School, Tunbridge Wells; Thomas Alleyne's High School, Uttoxeter; Whitecross School, Lydney.

All twelve finalists received a signed certificate to mark their achievements in reaching the finals of the 1983 SEDAC competition.

Winding up the ceremony the sponsors announced that the competition would be run again in 1984. Although it may widen its scope into other fields where electronics can be of benefit. Is this an inducement to attract the girls? Or are they too shy?

Contestants and teachers expressed their appreciation in the way the competition was organised by the joint sponsors. They were particularly grateful to Jackie Doidge, SEDAC Secretary, and Ron Powell, Mullard, for the efficient way they organised travel and accommodation for all finalists.

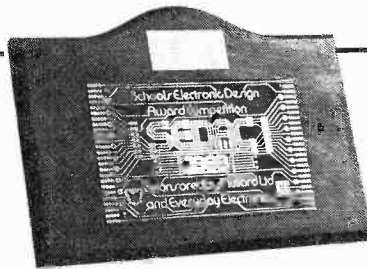

## SEDAC TROPHY

A specially designed trophy was awarded to the winner of the Schools Electronic Design Award Competition.

As a fitting symbol of contemporary electronics this trophy is in the form of a high grade glass-fibre printed circuit board. The copper tracks are gold plated.

The p.c.b. is mounted on a polished wooden base and this carries a small brass plate engraved with name of school and title of winning project.



Martin with the SEDAC Trophy awarded to the outright winner of the schools competition.

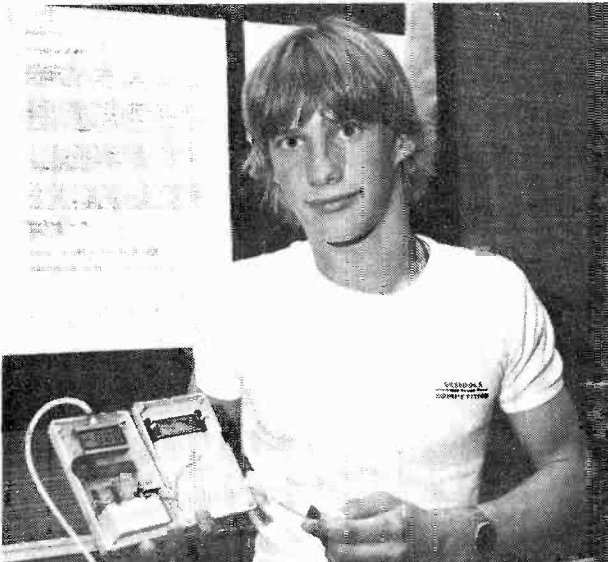

Robert shows off the Digital Gauss Meter which won 2nd prize.



Michael and Lorna receiving their 3rd-place awards from Ivor Cohen of Mullard.

## A VISITOR'S VIEW

The SEDAC 83 final was a close run event, as the standard of all the projects was high indeed.

It was interesting to note that seven out of the 12 finalists had decided to construct computer-based projects, emphasising the changing trend in schools today. Many of the competitors agreed that they were now geared towards computing rather than learning about the physical side of electronics.

The winner of SEDAC 83 was the Electronic Pendulum, entered by Martin Cragg (15) from the Roland Green School, Nottingham. The object of this project was to determine a value for "g", the acceleration due to gravity, using a pendulum linked to a BBC Microcomputer. In the three months it took to design the project a few problems were encountered by Martin, when dealing with the computer software and also the suspension of the pendulum, but these were all ironed out in time for the final. Ironically, Martin, who had hoped to get an apprenticeship in electronic engineering was turned down by Plessey at Beeston.

The runner-up of SEDAC 83 was the Digital Gauss Meter, entered by Robert Rowe (16), from Wymondham College, Norfolk. This instrument was constructed for the accurate measurement of small amounts of magnetic flux. It provides a fast and easy-to-use system at a budget price. The unit was designed specifically for an Engineering Design 'O' Level, but it was then decided to enter it for SEDAC 83. This was one of the few entries that is being turned into a commercial proposition, having been spotted by Scientific Systems Ltd., of Swindon.

The third prize winner, the Environmental Data Recorder, was entered by Michael Lawrie (15) and Lorna Wilkinson (13), from Hollins County High School, Lancashire. This was the only project amongst the finalists in which a girl participated in the technical design, and was again built especially for SEDAC 83.

The recorder was constructed

for field work and is a portable, water and weatherproof unit which reads analogue information from sensors, converts these to digital form and stores the information in a memory. The results can then be graphically displayed later, back in the laboratory via a computer and television screen.

It was a stimulating experience to walk around and examine the projects and to "chat-up" all the finalists.

Nearly all the competitors seemed keen to pursue a career in the electronic or computing fields, except Lorna from Hollins County High School, who thought she would rather pursue acting on the stage!

Reaching the final of SEDAC 83 was a great event for the competitors. The two-night's accommodation in a nearby hotel at the sponsors expense made this a pleasant and memorable trip to the capital. As one teacher clearly pointed out, his pupils had never been to London before and had been thrilled at the prospect of sight-seeing in the capital.

Talking to the competitors, it became apparent that a couple of the schools involved, although eager to take credit for their pupils success, were not very eager to give financial backing, in effect limiting the competitors to what they could personally afford in the way of components. In total contrast, it is pleasing to report that the competitors from Hollins County High School were provided with pocket money by the Parent Teachers Association. It was a general feeling amongst the contestants that the schools had not been a driving force behind them to enter the competition, and it was on their own initiative that they had managed to succeed.

Many people commented on how well the competition had been organised. It was thought by one or two participants that SEDAC 83 seemed a better run event than some Government backed schools competitions that they had previously entered.

# Electronic Design Award

# THE 1983 TWELVE WINNING DESIGNS



**B**IOLICAL and environmental science studies are difficult to carry out when the quantities to be measured change slowly. Experiments may take days or weeks to be completed and when field work is being done the problems are even greater.

This project is a portable, water- and weather-proof unit designed to read analogue information from sensors. The unit may be used to determine temperature changes, oxygen content, light levels and may also be used with other sensors.

The data is stored digitally in a memory having already been converted from analogue-to-digital by an 8-bit converter. The results are

**Environmental Data Recorder**  
Hollins High School, Accrington

Michael Lawrie (15)  
Lorna Wilkinson (13)  
Mr. J. S. Hagan (teacher)

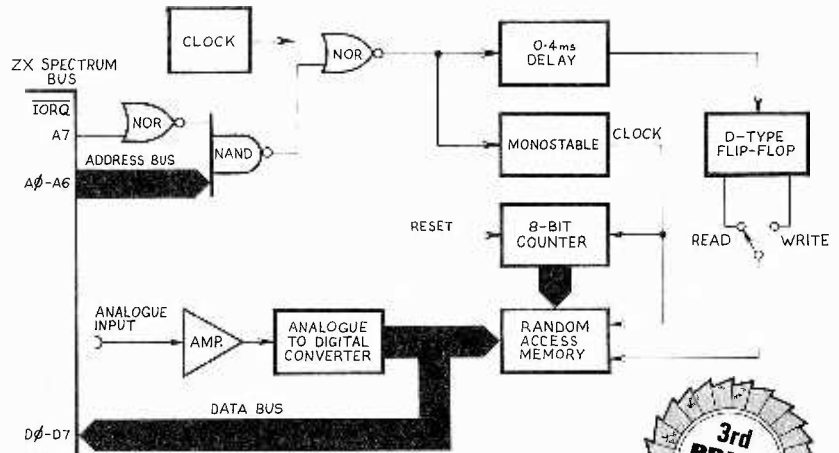

then graphically displayed back in the laboratory via a computer and a television screen. As the project is designed as a portable unit it was decided to use rechargeable batteries as a power supply.



**T**HE purpose of the Logic Gate Demonstrator is to provide a visual demonstration of the operation of the five common logic gates, AND, OR, NAND, NOR and EX-OR such that the truth tables of these gates can be easily understood.

The project is intended for use in a class of about 20 pupils and therefore the display has to be of a size which will be easily visible and clear to the pupils. The display board of dimensions, 44cm by 60cm uses 6V indicating lamps.

**Logic Gate Demonstrator**  
Mill Hill School, London

G. Chelliah (16)  
Dr. W. D. Phillips (teacher)

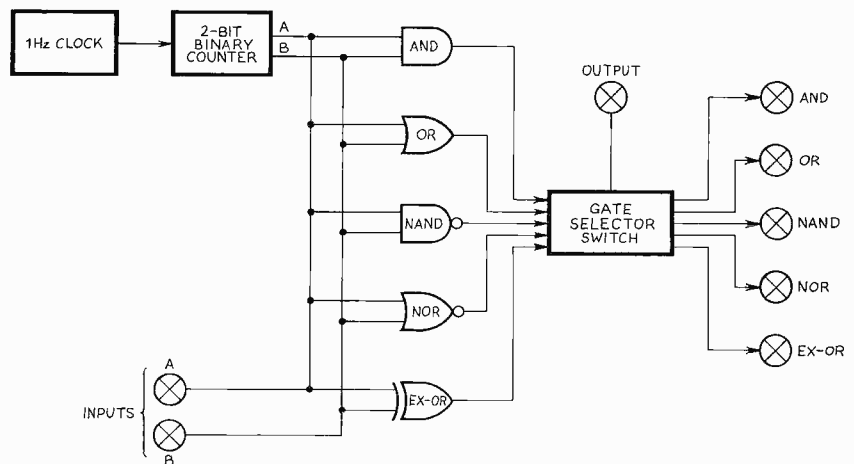

The circuit design consists of a multi-vibrator producing pulses at approximately 1Hz. These pulses are then fed to a 2-bit binary counter which drives the inputs of the

five logic gates. The output to be displayed is selected by means of the gate selector switch and at the same time the corresponding indicator lamp is illuminated.



**T**HE Compu-Colorimeter is designed to use a computer to record data for experiments determining rates of chemical reactions. The



**T**HIS project allows the ZX81 and ZX Spectrum to control external pieces of equipment and also to monitor external equipment. The unit provides eight input lines and eight output lines, and these may be used individually or in groups.

The port is input/output mapped as opposed to being memory mapped which means

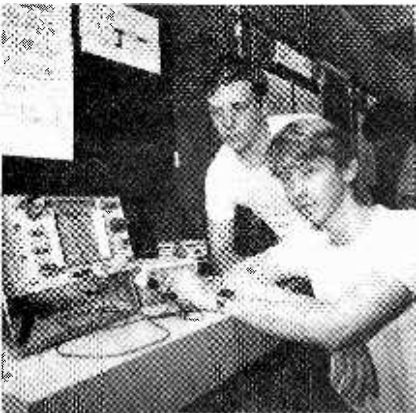

**D**URING experiments in the physics laboratory which require the measurement of waveforms lasting no longer than a few milliseconds, it occurred that it would be easier and more accurate if the waveform were frozen on the oscilloscope screen.

## Compu-Colorimeter

Ousedale School, Newport Pagnell

Mark Cole (17)

Mr. W. G. Thomas (teacher)

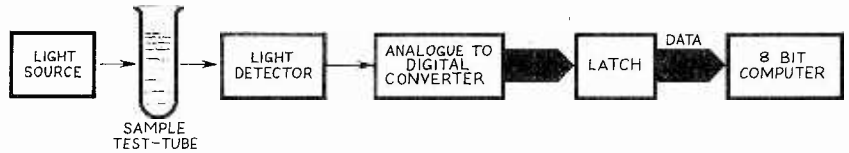

electronics have been kept simple, and complex Basic and Z80 Assembly language programs developed to process the data.

Operation consists of a light source which passes through a filter to obtain optimum wavelength and then through a test-tube containing the reacting solutions and on to a light dependent resistor. As the reaction commences, the colour of the solution changes and varying amounts of light fall on the light detector.

The equipment contains two separate compartments, optically sealed so light can only pass through the test-tube containing the reaction.

The voltage at the output of the detector is proportional to the light intensity, and is converted to a digital number and set up in a latch to be read by the computer's 8-bit input port. The software inputs data at set intervals, stores it, calculates results and displays them graphically.

## ZX Input/Output Port

Parkview School, Barrow-in-Furness

M. Cowperthwaite (16)

Mr. S. J. Redding (teacher)

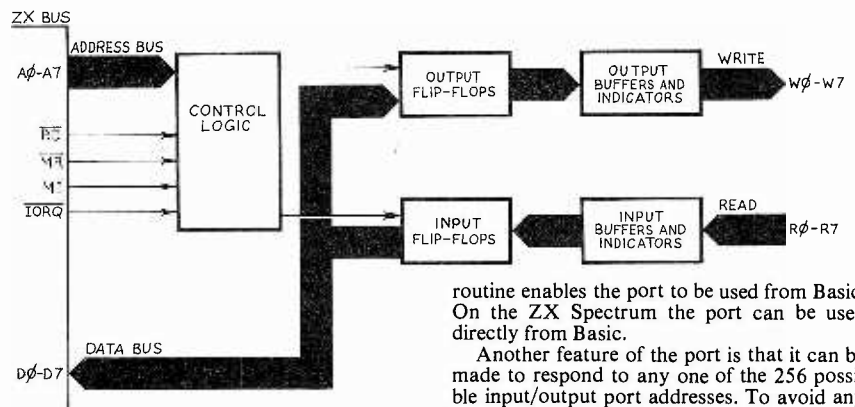

that the unit is compatible with any memory mapped device.

When using the ZX81, the port, being input/output mapped, cannot be used directly from Basic. However, a short machine code

routine enables the port to be used from Basic. On the ZX Spectrum the port can be used directly from Basic.

Another feature of the port is that it can be made to respond to any one of the 256 possible input/output port addresses. To avoid any clashes between the port and other input/output mapped devices (ZX printer), a d.i.l. switch is built into the circuit. Hence, the port can be made compatible with virtually any other piece of hardware just by altering a few switches.

## Storage Oscilloscope

Princess Margaret Royal Free School, Windsor

Ron Hejdeman (17)

Andrew Wilding (17)

Mr. G. Mort (teacher)

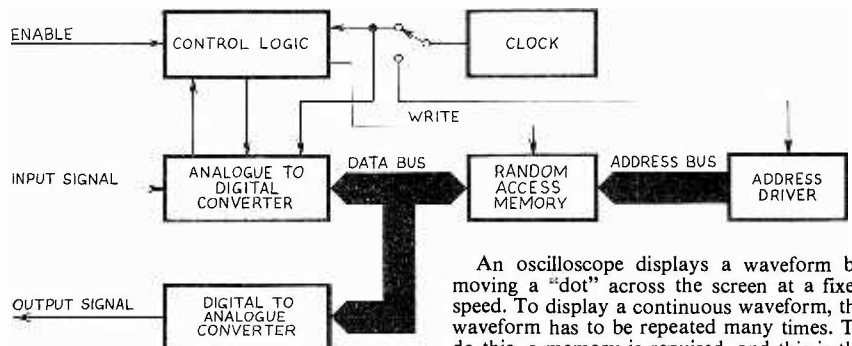

An oscilloscope displays a waveform by moving a "dot" across the screen at a fixed speed. To display a continuous waveform, the waveform has to be repeated many times. To do this, a memory is required, and this is the basis of this design.

To enter the waveform into the memory, it has to be converted into binary using an analogue-to-digital converter. And to convert it back to a voltage for the oscilloscope, a digital-to-analogue converter is employed. Logic is used to synchronise all functions.

There is a type of oscilloscope which can do this, known as a storage oscilloscope, however, these are expensive, therefore an unviable proposition for schools. As a result, an alternative was designed to convert a normal oscilloscope into a storage instrument.





## Telephone Interface for Micros

David Omar (16)  
Julian Danton (16)

The Ridings High School, Winterbourne

Mr. P. S. Maund (teacher)

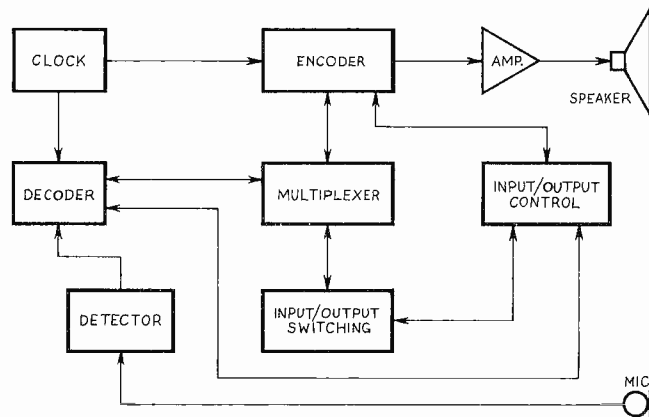

THE unit was designed as a general purpose telephone interface for any 8-bit microprocessor. The memory of the computer is converted into an audio signal, which is then passed down a telephone line and converted back to a digital signal. This signal is then stored in the memory of the receiving computer.

The main design considerations were operation, speed and synchronisation. Transmitting clock pulses was discarded as it halved the

speed of data transmission, this meant an accurate clock was needed. The accurate clock pulse is provided by a crystal oscillator.

The units only requirements are a  $\pm 5V$  power supply, a suitable interface with two 8-bit programmable ports and suitable software.



## Electronic Pendulum

Martin Cragg (15)

Roland Green School, Wilford

Mr. L. Haywood (teacher)

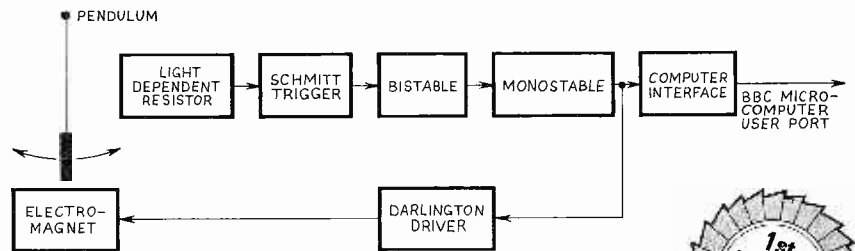

THE object of this project is to determine a value for "g", the acceleration due to gravity, using a pendulum linked to a BBC Microcomputer. Experimental time is reduced and a fairly accurate value of "g" may be determined. It can also be used to show how errors can be reduced by increasing the number of pendulum swings.

A pendulum is kept swinging at a constant amplitude by an electromagnet housed below the pendulum. A pulse from a light dependent

resistor placed just above the electromagnet is obtained by the pendulum preventing light falling on it. This pulse is then fed into a bistable, which causes the bistable to change state and remain so, until a second pulse is supplied. As soon as the bistable has changed state a pulse is supplied to a monostable causing it to change state. The output from the monostable causes a large current to flow in two transistors wired as a Darlington pair.

After a short delay the monostable will

return to its stable state and the Darlington pair will energise the electromagnet giving a kick to the pendulum. The computer keeps count of the number of pendulum swings and then calculates "g".



## ALL THE WINNERS!

The twelve '83 finalists  
outside Mullard House  
on Presentation Day

**WHO WILL BE IN THE  
PICTURE NEXT YEAR?**

Everyday Electronics, September 1983

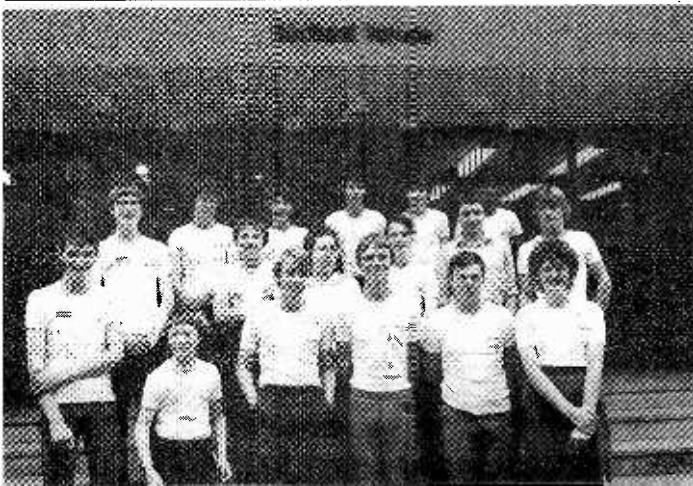



**T**HIS unit is designed to replace the mercury thermometer. Its main application will be for classroom demonstrations due to the large digital display and the ability to remember temperatures taken every  $2\frac{1}{2}$  seconds.

The temperature sensor is a constant current generator whose output is directly proportional to the Kelvin temperature. This current is converted to a voltage and the next stage converts this voltage to time. The output is ANDed with the clock and the result is a number of pulses equal to the Kelvin temperature.



**T**HE unit was designed as an aid to increasing the accuracy of experiments where a precipitate is timed as it forms. The design improves on the crude methods of timing used in schools at present and should be of value in work at all levels of chemistry. Throughout the design, emphasis has been put on the accuracy of about half a second, and the cost which schools would be able to afford.

## Digital Thermometer with Memory

Paul Thorlby (15)  
Paul Rock (16)

Skegness Grammar School, Skegness

Mr. G. W. Payne (teacher)

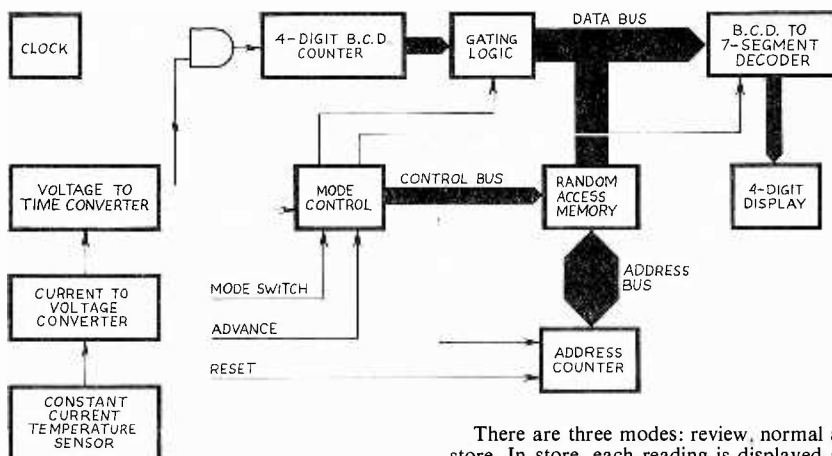

These are counted by a 4-digit b.c.d. counter. The control logic, routes each reading to and from the memory, display and counter via a data bus.

There are three modes: review, normal and store. In store, each reading is displayed and remembered. In review, the measuring apparatus is disabled and readings taken from the memory, and in normal, the memory content is safeguarded and the unit displays readings, but does not record them in the memory.

## Precipitation Reaction Timer

David Lewis (16)  
Duncan Reed (17)

Skinner's School, Tunbridge Wells

Mr. L. T. Goldsmith (teacher)

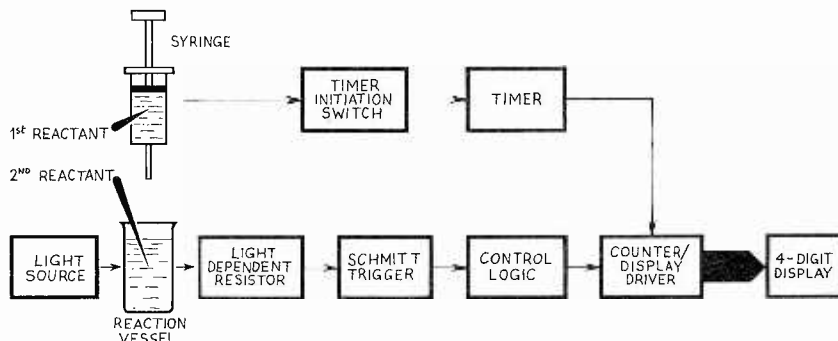

The timer itself consists of a light shining through the reaction vessel onto a light dependent resistor (l.d.r.). As the precipitate thickens the resistance of the l.d.r. increases and this increase is used to control a switching circuit, which in turn stops a 4-decade counter timing the reaction.

The time in seconds and tenths of seconds is displayed on four 7-segment l.e.d. displays. The timer is started on the addition of the second reactant, the first having been placed in the reaction vessel. The timer is housed in a plastics case which contains all the electronics and the reaction chamber.

MULLARD and EVERYDAY ELECTRONICS are pleased to announce next year's Schools Electronic Design Award Competition—SEDAC '84.

★ Scholars and teachers are urged to give thought now to their school's participation in this challenging National Contest.

## AWARDS FOR WINNERS

The SEDAC TROPHY to the outright winner  
Valuable cash prizes to the first three winners

Boxes of electronic components and technical data booklets to all twelve finalists—plus a certificate and one year's subscription to Everyday Electronics

and All-Expenses-Paid Two-Day visit to London.

**FULL DETAILS NEXT MONTH**



**T**HIS project is intended for use in the chemistry laboratory and is a device which extends the capabilities of a pH meter by linking it to a Research Machine 380Z using Control Basic.

Precise measurements can now be carried out to a great degree of accuracy instead of using a colour change with an indicator, or a measurement on an analogue meter, as numerical representation can be given. Graph plots may also be provided by the computer during chemical reactions.



**T**HE circuit is a complete unit for interfacing the ZX81 in a school science laboratory. The unit has its own power supply, supplying 1A to the circuit, and also the external circuitry if connected.

The circuit has seven defined parts; a selection system for selecting which part of the circuit is being used; the expansion port which enables timers and meters to be connected; analogue-to-digital and digital-to-analogue converters; a ROM port equipped with an EPROM Programmer for +5V rail EPROMs; a



**T**HIS instrument is designed for accurate measurement of small amounts of magnetic flux in the range  $\pm 2000$  gauss. It provides a cheap and easy to use system, within a school's budget.

The device uses a Hall effect transducer for detection of a magnetic field, this being moun-

### Computer Interface for Analogue pH Meter

Thomas Alleyne's High School, Uttoxeter

Stephen Bailey (16)

Mr. A. H. Orme (teacher)

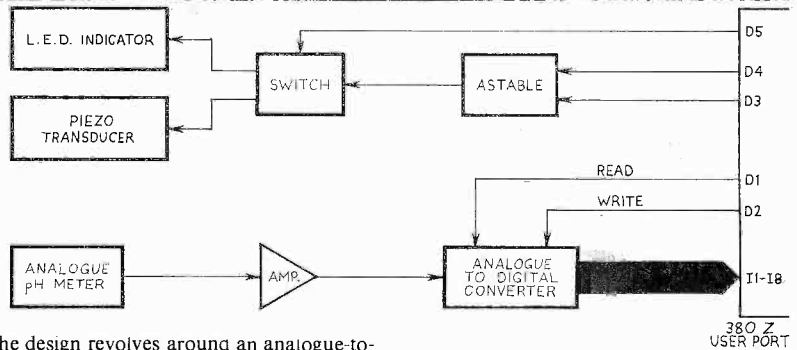

The design revolves around an analogue-to-digital converter which converts the varying analogue voltage from a normal pH meter and digitises it, so that it can be used by the 380Z. Before this stage there is a variable gain amplifier and buffer which obtains full graphical range from the 380Z.

The final part of the proposed project is the audible feedback oscillator which alerts the

operator that a certain pH value is about to be reached by producing two tones. A visual indicator is also provided if it is more suitable in certain conditions.

All major controls such as sampling rate and warning system switching are software based therefore maintaining the flexibility of the whole system.

### ZX81 Expansion System

Whitecross School, Lydney

Peter Jarvis (14)

Katy Jarvis (18)

Mr. M. C. Jarvis (teacher)

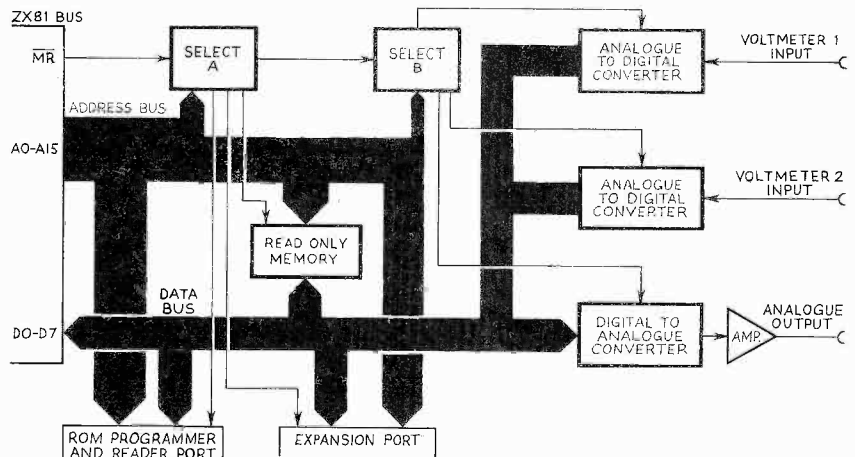

### Digital Gauss Meter

Wymondham College, Wymondham

Robert Rowe (16)

Mr. J. Edwards (teacher)

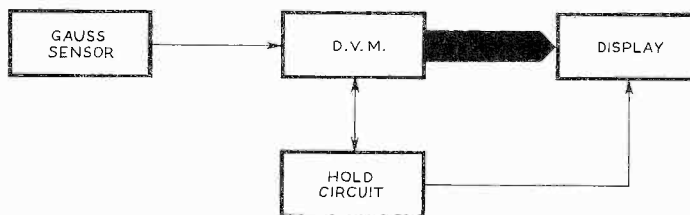

ted in a probe. The sensor gives a differential output, dependent on the strength and polarity of the magnetic field. This is fed into a digital voltmeter i.c. The sensor is biased to be linear up to  $\pm 3000$  gauss.

The d.v.m. gives a  $3\frac{1}{2}$  digit liquid crystal display of the differential voltage applied to its input. A hold feature was essential to freeze

the display as small movements of the probe resulted in large changes in the magnetic field.

The 7106 d.v.m. i.c. employed in the design does not have an internal hold facility, so an external circuit was added. This uses an external clock and multiplexer, the latter necessary to prevent the display being destroyed by a constant d.c. drive voltage across it.

## ADDITIONS TO OUR LIST

### RADIO MOBILE CAR RADIO SPEAKERS

9" x 4" 4 ohm 5 watt — £1.70, 6" x 4" 3 ohm 4 watt — £1.35; 6" x 4" 4 ohm 4 watt — £1.15, 6" x 4" 16 ohm 4 watt — £1.15; 5" round 8 ohm 10 watt — £2.50, 5 1/2" round extra thin for door or back shelf. In fact these are only 1/8" thick 16 ohm 5 watt — £1.75; 5" round 16 ohm 5 watt chassis size 5 1/4" square (approx.) — £1.15; 5" round 4 ohm 5 watt with built in tweeter — £1.15; 9" x 3" 8 ohm £1.15.

**IMPORTANT NOTE:** The speaker prices above do not include postage but 10 or more speakers are post free — otherwise add £1.50 per order.

### STABILISED POWER SUPPLY (Mains Input)

By LAMDA (USA) — Ideal for computer add-ons, d.c. output. Regulated for line volts and load current. Voltage regulation .1% with input variations up to 20% — load regulation 1% from no load to full load — or full load to no load. Complete in heavy duty case — Models available: 5v — 6A £1.25, 5v — 9A £2.3, 12v — 1.5A £1.25, 15v — 1.2A £1.25, 24v — 2A £2.3.

### PREPARED APPLIANCE LEADS

Buy these, they will save you time and money. Prices are for small quantities but if you are buying £100 lots or more — halve the prices. Twin circular, white .5mm length 54" — 23p; 3 core circular, white 99" — 1.25mm — 5.7p, Twin circular black 77", 5mm — 23p; 3 core circular, black 89", 5mm — 35p, 84", 5mm 46p; Twin circular black 114" 1.25mm — 69p. Twin circular white 200", 75 fitted 2 pin continental plug one end — 57p; 3 core circular white 54", .75mm core sizes fitted continental two pin and earth plug one end and new type 3 flat pin appliance connector at other end — 75p.

### MINIATURE TOGGLE SWITCHES

As used on TV cameras and other lightweight equipment. American made by the Arrow Company.  
Arrow ref. TCH3E Single pole changeover, centre off — 46p.  
Arrow ref. TSH3PCL Single pole changeover PCB mounting — 46p.  
Arrow ref. TCB6M Double pole changeover, centre off — 69p.

### REED RELAY KIT

High inductance coil, moulded to take 4 reeds, operated by three volts DC or 12 ma. Could be used to close 4 circuits, or with the external magnets supplied, you could have two normally open, i.e. two changeovers. An exceptional bargain at 99p for the coil — 4 reeds and 2 magnets.

### ROCKER SWITCHES

Standard size fit 11.5 x 28mm cut out. Single pole on/off — 23p; Single pole changeover 28p; Single pole changeover with centre off — 30p; Single pole on/off with neon — 46p, for double width cut out DpSt 36p, DpDt 46p.

### NICAD BATTERY CHARGERS

This, although intended to charge button cells, brings leads from the contacts and then it will suit almost any Nicad battery, charge rate approximately 15mA but easy to vary.

### MIXER MOTOR

If this had a case around it, it would be a complete mixer as it has a speed control switch giving three changes of main speed and it also has a gear box with two sockets for paddles. Three lower speeds are available from these sockets. £3.45 — post 60p.

### LOW VOLTAGE SWITCH

Approx 1 1/2" diameter, the cover unscrews to enable the switch to be fixed and to keep the contacts covered, contacts look capable of up to 10 amps. 23p.

### PILOT BULBS

Standard round 11mm 6.5v .3a by Philips. Box of 10 price 50p.

### 12 volt MOTOR BY SMITHS

Made for use in cars, etc., these are series wound and they become more powerful as load increases. Size 3 1/2" long by 3" dia. They have a good length of 3/8" spindle — Price £3.45.  
Ditto, but double ended £4.25.  
Ditto, but permanent magnet £3.75.



### EXTRA POWERFUL 12v MOTOR

Made to work battery lawnmower, this probably develops up to 4 h.p., so it could be used to power a go-kart or to drive a compressor, etc. etc. £7.95 + £1.50 post.  
(This is easily reversible with our reversing switch — Price £1.15).

### MAINS MOTORS

We have very large stocks of motors from 2 watts to 1/4 hp. Most at a price well below cost, let us know your requirements. Some new ones just arrived.

67 R.P.M. Motor: 1/10 hp, reversible mains operated split phase motor with gear box — shaft fitted with chain sprocket £11.50 plus £2 post.

100 R.P.M. Motor: 1/16 hp. Mains driven reversible motor with gear box, 3/8" shaft from gear box — Very powerful £16.50 plus £3 post.

BALANCED MOTOR: Disc or tape drive motor 1500rpm reversible — mains operated. 3" dia 2 1/2" long with good length 3/8" spindle £4.60 plus 80p post.

### CROSSOVER NETWORKS

2-way: 4 or 8 ohm — power input up to 25W, crossover frequency 2kHz with wiring dig. 87p each.

3-way: 4 or 8 ohm — power input up to 60W, crossovers at 700kHz and 3500kHz with wiring diagram. £1.15.

### — BARGAIN OF THE YEAR —

### The AMSTRAD Stereo Tuner.

This ready assembled unit is the ideal tuner for a music centre or an amplifier, it can also be quickly made into a personal stereo radio — easy to carry about and which will give you superb reception.

Other uses are as a "get you to sleep radio", you could even take it with you to use in the lounge when the rest of the family want to view programmes in which you are not interested. You can listen to some music instead.

Some of the features are: long wave band 115 — 270 KHz, medium wave band 525 — 1650KHz, FM band 87 — 108MHz, mono, stereo & AFC switchable, tuning meter to give you spot on stereo tuning, optional LED wave band indicator, fully assembled and fully aligned. Full wiring up data showing you how to connect to amplifier or headphones and details of suitable FM aerial (note ferrite rod aerial is included for medium and long wave bands. All made up on very compact board.

Offered at a fraction of its cost: **only £6.00** + £1.50 post + insurance.

## THIS MONTH'S SNP

A PRESTEL UNIT, complete except for 6 plug-in IC's — so far as we know



the unit would work once the missing IC's are fitted. Price: £19.75 + £2.00 Post. Contains all the items listed below.

### VIEWDATA EQUIPMENT

ORACLE VB 100 PCB This is the heart of many viewdata systems, including the Prestel Unit which we are currently selling. This board uses 25 I.C.'s, 5 transistors, 2 crystals and very many other components. It has a TV aerial input and a TV UHF modifier (AZTEC UM 1233). We offer this board, now, unused and complete except for 6 of the 25 I.C.'s at £5.75. The plug in holders for the missing I.C.'s are on the board wired ready to receive them.

**MINIKEY SERIES KL** This is an American made membrane keyboard with silver contacts as used on Prestel to dial into the British Telecom phone system. It is really miniature, only 60mm x 65mm x 5mm thick. It has 16 press buttons, giving standard 0-9 numbers and ABCD facilities. There are two other buttons engraved asterisks. This is an extremely well made board. £4.60.

**TELEPHONE LINE TERMINATION UNIT** As used with Prestel but undoubtedly suitable for other applications. Important components are phone line isolation transformer and 3 Clare Reed Relays. All mounted on a pcb with 1 I.C. and other components P.C.B. size approximately 7" x 1 1/2" — £3.45.

**VOLTAGE STABILISED POWER SUPPLY** As used with Prestel, this has a mains input transformer with a 13v - 0 - 13v 20 watt mains transformer. Rectifiers and semi-conductors all mounted on P.C.B. size approximately 4 1/2" x 2". The stabilised DC output from this is — 27v — 12v — 0 — +0 +12v +27v. Price £4.60.

**INSTRUMENT CASE** As used with the Prestel unit this comprises an aluminium chassis and a moulded front plastic cover secured to the chassis by self-tapping screws. Overall size approx 12" x 10" x 2 1/2" deep. On the front is fitted the minkeyboard as described above and although originally intended for Prestel, this case should have other uses including telephone answering machine, etc. Price £5.75 + £1.50 post.

### X-RAY EQUIPMENT

Beautifully made by the American GEC Company. We have a whole range of spares, all unused. X-RAY TROLLEY This could be motorised, mains or battery driven with self retractable flex lead, so it could be used for carrying other mains operated equipment which need to be manoeuvred easily in a relatively confined space. Switching and breaking is done from the handle and there is ample room and capacity for heavy transformers and smaller equipment. The overall size of this trolley is approx. 3' x 2' x 3'6". Price £69.  
X-RAY HEAD This comprises the x-ray tube in a radiation proof housing with plug in lead connectors. The tube enclosed in the housing is a hospital size tube and unused and new. Price £69.  
EHT TRANSFORMER & RECTIFIER UNIT We estimate that the output voltage of this is probably 30 or 40 kV. Completely enclosed in an oil filled container, size 13" x 14" x 15". There are four rectifier sections, each using 20 EHT rectifiers connected in series these plug in for ease of replacement. The unit is powered by a 600 cycle supply. Price £69.  
600 CYCLE SUPPLY UNIT Mains operated through a step down transformer, this contains all the electronic components to operate the equipment. Price £57.50.

### MINI MONO AMP

on p.c.b., size 4" x 2" (app.) Fitted volume control and a hole for a tone control should you require it. The amplifier has three transistors and we estimate the output to be 3W rms. More technical data will be included with the amp. Brand new, perfect condition, offered at the very low price of £1.15 each, or 10 for £10.00.



## 50 THINGS YOU CAN MAKE

Things you can make include: Multi range meter, Low ohms tester, A.C. amp meter, Alarm clock, Soldering iron minder, Two way telephone, Memory jogger, Live line tester, Continuity checker, etc. etc., and you will still have hundreds of parts for future projects. Our 10Kg parcel contains not less than 1,000 items — panel meters, timers, thermal trips, relays, switches, motors, drills, taps, and distats, tools, the mosts, coils, condensers, resistors, neons, earphone/microphones, nicad charger, power unit, multi-turn pots and notes on the 50 projects.

**YOURS FOR ONLY £11.50 plus £3.00 post.**

### MINI-MULTI TESTER

Deluxe pocket size precision moving coil instrument, jewelled bearings — 2000 o.p.v. mirrored scale. 11 instant range measures: OC volts 10, 50, 250, 1000, AC volts 10, 50, 250, 1000, DC amps 0 — 100 mA.



Continuity and resistance 0 — 1 meg ohms in two ranges. Complete with test probes and instruction book showing how to measure capacity and inductance as well. Unbelievable value at only £6.75 + 60p post and insurance.

**FREE** Amps range kit to enable you to read DC current from 0 — 10 amps, directly on the 0 — 10 scale. It's free if you purchase quickly, but if you already own a Mini-Tester and would like one, send £2.50.

## J. BULL (Electrical) Ltd.

(Dept. EE), 34 - 36 AMERICA LANE, HAYWARDS HEATH, SUSSEX RH16 3QU. Established 30 YEARS

MAIL ORDER TERMS: Cash, P.O. or cheque with order. Orders under £12 add 60p service charge. Monthly account orders accepted from schools and public companies. Access & B/card orders accepted day or night. Haywards Heath (0444) 454563. Bulk orders: write for quote. Shop open 9.00 — 5.30, noon to Fri, not Saturday.

## EXTRACTOR FANS

Mains operated — ex-computer. Woods extractor 5" — £5.75, Post £1.25 6" — £6.95, Post £1.25 5" Plannair extractor £6.50, Post £1.25.

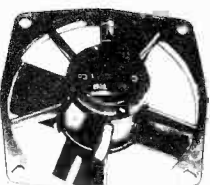

4" x 4" Muffin 11.5v. £4.50, Post 75p. 4" x 4" Muffin 230v. £5.75, Post 75p. 9" American made £11.50, post £2.00. 12 volt 60p extractor £6.90, post £1.50.

## AUTO & ISOLATION TRANSFORMERS

2 KW ISOLATION TRANSFORMER 230v in 230v out with tapped primary and secondary, facilities any voltage changes that might be needed. This is a very heavy transformer, American made but not encased. The terminals are along the top on insulation board panels. Both primary and secondary are split so this could also be used as a 2KW isolation step down transformer. £57.50 Carriage at cost depending upon the distance. This is approx half the regular price.

2 KW AUTO TRANSFORMER Similar type of transformer to the above but has only the one winding. £28.50 + carriage £3.  
1 KW ISOLATED AUTO TRANSFORMER It is not generally realised that many of the American made tools intended for 115v, if used on building sites and similar damp conditions must be isolated from the mains for safety reasons, as in many cases the insulation of this equipment is not good enough for 230v. We have American made isolated auto transformers, completely enclosed in sheet metal case with carrying handle with 230v lead and 110v American type plug. Price £46.00 + £4.50 post.

300 WATT AUTO TRANSFORMER completely encased, lead for the 230v input, American type plug for the 115v output £6.90 + £1.50 post.

100 WATT AUTO TRANSFORMER not enclosed terminals, output primary with tappings for voltage adjustments. Made to rigid specification for the GPO £4.60 + £1 post.

AMERICAN 2 PIN FLAT SOCKETS for use with these auto transformers — £2.30 each.

## 3M FACSIMILE EQUIPMENT

— send or receive a document in 4 minutes. This equipment is used for sending letters and almost any data through the telephone system — "Mail by Phone". The machines we have are the 3M 600BB with autofeed complete with ansafonettes and connector box. We have three sets of the equipment, it is not old, in fact it was used only for about a year (1980-81), believed to be in good order and certainly in a very good condition — cost new over £10,000. We will accept £500 the lot — buyer to examine and take away on an "as seen" basis.



## VENNER TIME SWITCH

Mains operated with 20 amp switch, one on and one off per 24 hrs, repeats daily automatically correcting for the lengthening or shortening day. An expensive time switch but you can have it for only £2.95. These are without case but we can supply a plastic case — £1.75. Also available is adaptor kit to convert this into a normal 24 hr. time switch but with the added advantage of up to 12 on/off per 24 hrs. This makes an ideal controller for the immersion heater. Price of adaptor kit is £2.30.

## IONISER KIT

Refresh your home, office, shop, work room, etc. with a negative O.N. generator. Makes you feel better and work harder — a complete mains operated kit, case included. £11.95 plus £2.00 post.

## OTHER POPULAR PROJECTS

- R C Bridge Kit £9.95
- 3 Channel Sound to Light — with fully prepared metal case. £14.95
- Ditto — made up £25.00
- Big Ear, listen through walls £9.50
- Robot controller — receiver/transmitter £9.50
- Ignition kit — helps starting, saves petrol, improves performance £13.95
- Silent sentinel Ultra Sonic Transmitter and receiver £9.50
- Car Light 'left on' alarm £3.50
- Secret switch — foats friends and enemies alike £1.95
- 3 — 30v Variable Power Supply £13.80
- 2 Short & Medium wave Crystal Radio £3.99
- 3v to 16v Mains Power Supply Kit £1.95
- Light Chaser — three modes £17.50
- Mullard Unix Hifi stereo amplifier with speakers £16.75
- Radio stethoscope — fault finding aid £4.80
- Mug stop — emits piercing squak £2.50
- Morse Trainer — complete with key £2.99
- Drill control kit £3.95
- Drill control kit — made up £6.95
- Interrupted beam kit £2.50
- Transmitter surveillance kit £2.30
- Radio Mike £6.90
- FM receiver kit — for surveillance or normal FM £3.50
- Seat Belt reminder £3.00
- Car Starter Charger Kit £14.00
- Soil heater for plants and seeds £16.50
- Insulation Tester — electronic megger £7.95
- Battery shaver or fluorescent from 12v £6.90
- Matchbox Radio — receives Medium Wave £2.95
- Mixer Pre-amp — disco special with case £16.00
- Aerial Rotator — mains operated £29.50
- Aerial direction indicator £5.50
- 40 watt amp — hifi 20hz — 20kHz £9.50
- Microvolt multiplier — measure very low currents with ordinary multimeter £3.95
- Pure Sine Wave Generator £5.75
- Linear Power output meter £11.50
- 115 Watt Amplifier 5Hz 25KHz £13.50
- Power supply for one or two 115 watt amps £17.50
- Stereo Bass Booster, most items £8.95





THE Sinclair ZX81 has, almost single handedly, been responsible for the boom in home computing and this familiar little "black wedge" can now be purchased for less than £40, a reduction of some 40 per cent on the original price. Still a best-seller in spite of the introduction of its big brother, the Spectrum (see *Special Report*, June '83 issue), the diminutive 1K ZX81 is as readily available from the high street chain store as it is from the computer specialist.

So what do you get for your money? The package comes complete with the computer console, a 9V mains power pack, a 1.2m long aerial lead to connect to a TV set, a pair of leads to hook up to a cassette recorder and the 210-page BASIC programming manual. Also included is a software catalogue listing all currently available Sinclair software tapes and introductory leaflet.

So all you need to supply is a 3-pin mains plug and a UHF television set (that is, one that receives BBC2 in the UK) and you can start computing.

### SETTING UP

The first chapter of the manual covers the initial setting-up procedure and this is a simple matter. The television set is connected to the ZX81 via the aerial socket and the mains power pack is plugged in. The TV has to be tuned-in (using a spare channel button on push-button sets or just a little way past BBC2 on rotary controls) and this is achieved when a little "K" appears in a black square in the bottom left-hand corner of the picture.

I initially found a slightly fuzzy picture when working on a large colour TV set—as well as it being slightly inconvenient crouched on the floor in front of it. Hardly the ideal working position! However, this is a criticism of the television and not the computer for when used with a portable black and white set, the picture was pin-sharp. And a far more comfortable work station is created with the whole set-up on a table top.

The 40-key keyboard measures only 150 x 50mm and is of membrane construction. That is, it has no moving parts, you simply touch the required key. Now this technique has recently come in for quite a lot of bad press and a whole multitude of full-size, moving-key keyboards have sprung up as add-ons.

I personally found this criticism a little unjust for, with practice, it is possible to

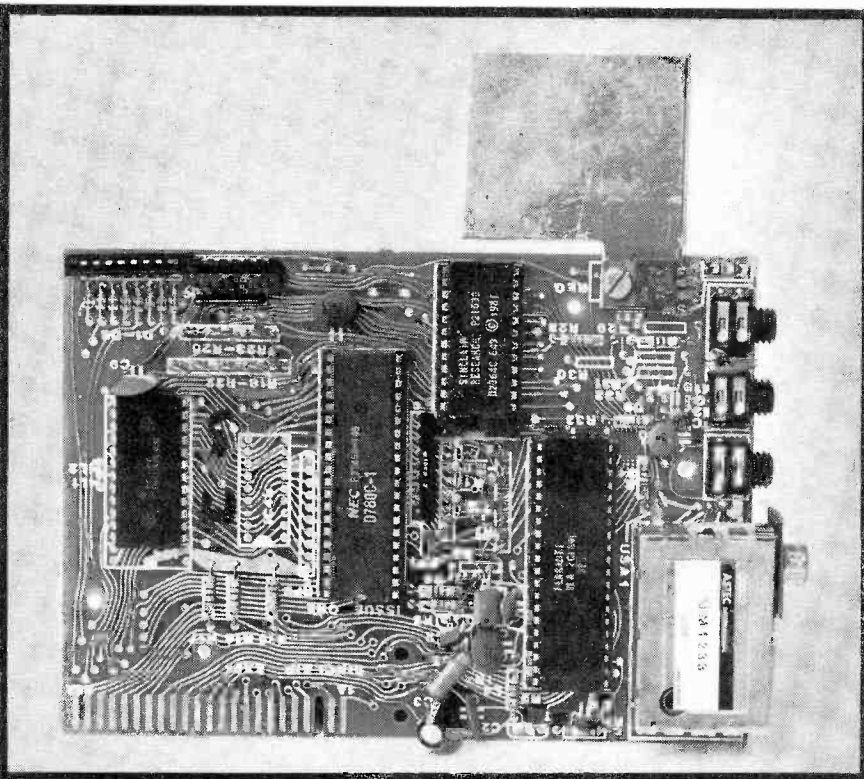

(Top) The ZX81 package comes with computer, 9V power pack (excluding mains plug), programming manual and leads for TV and cassette. (Above) The p.c.b. showing the finger set to connect the printer and extra memory.

# SPECIAL REPORT

# ZX81 PERSONA



become quite proficient with the original membrane version. It does of course mean that you have to look at the keyboard and not the screen when entering data, but how many of us can touch-type anyway?

## MEMORY

One of the most important parts of a computer is the memory in which it stores data and instructions in order to carry out the programs. The unexpanded ZX81 has 1K bytes of user memory and this is known as RAM (Random Access Memory). This means that it has 1024 (1024 and not 1000 because 1K is equal to  $2^{10}$  bytes in binary) memory locations for system management.

This is not a great deal by modern standards but certainly enough to introduce the user to programming techniques. It is, of course, expandable by 16K with the add-on RAM pack.

The ZX81 uses BASIC as its programming language and the central processor or "brains" of the computer (in this case, the popular Z80A processor) does not directly understand BASIC instructions. So a further memory is required to interpret the BASIC and provide instructions the processor can understand.

This additional memory is known as the ROM (Read Only Memory) and the ZX81 has 8K bytes of ROM. The contents of the ROM cannot be changed by the user whereas the RAM can be altered at will but RAM is lost when the power supply is disconnected whereas ROM is not.

## PROGRAMMING

The ZX81 BASIC programming manual assumes no prior knowledge of computer programming and starts at absolute basics (excuse the pun!). Within minutes, the user is operating the ZX81 as a calculator and becoming familiar with the way to enter a problem and execute the answer.

But a simple calculator the ZX81 is not, and it very soon becomes apparent that it is capable of handling far more complex problems. The next few chapters introduce the BASIC functions, variables and strings used in programming.

By chapter eight (and it is advisable to follow chapters in numeric order) the beginner is actually running a simple program concerning the varying price of vegetables! The following chapter has you running a few more serious

programs, for example extracting square roots, and it starts to fall into place.

As previously stated, the ZX81 uses Sinclair BASIC and this language uses "keywords" for all instructions. Now BASIC follows normal English as closely as possible and, for example, the language uses the PRINT command to literally "print" a result on the screen.

The ZX81 has all these keywords as single key entries and to use the same example, if the program requires a result to be displayed, the first pressing of the "P" key will give the PRINT command, without the need to spell the keyword in full. All subsequent pressings of this key will give the single character "P" until a new line of program is started.

All new lines of program are given a number and the computer will automatically place these lines in order. The normal standard is to number the lines 10, 20, 30 and so on in multiples of ten so that if an additional unforeseen line is required (and this is usually the case, even with experienced programmers), it can be added between two previous lines and the ZX81 will insert it at the correct location.

The ZX81 is not particularly fast and it can take a number of seconds, even minutes, to execute a program. However, it does have two modes of operation, FAST and SLOW. Under normal circumstances, it operates in SLOW mode and displays all operations as they happen. If the FAST mode is requested, it blanks out the screen during a program run (and as the display takes up memory space, it also takes up time) and consequently, the program runs much faster.

## GRAPHICS

The display of the ZX81 has 22 lines of 32 characters making a total of 704 picture elements. Each of these picture elements is sub-divided into four portions, each known as a pixel. Each individual pixel can be addressed by its coordinates (using the PLOT command) resulting in a graphics screen area of 42 by 64 pixels. Note that the bottom two lines of the screen cannot be used for either PRINTing or PLOTting.

As such, the display is fairly low resolution and only in black and white. The standard graphics characters do, however, include a set of symbols that allow the pixels to show a kind of chequered pattern that gives the effect of a half-tone, so quite effective pictures can

be generated for games.

The display can also be animated by instructing the computer PLOT and then UNPLOT pixels, giving the effect of movement.

Now, assume you have mastered the fundamentals of programming and wish to save a program. Switching off the machine will erase all that is in the RAM so the program will have to be stored on cassette tape. The ZX81 has a cassette interface to do just this and the procedure is fairly simple.

All that is required is a normal mono cassette recorder (a stereo recorder will work but better results are obtained on cheaper, mono machines) and a blank tape. The computer is connected to the recorder via the two leads supplied. These leads come with 3.5mm jack plugs at either end so if your recorder uses different connectors, a special lead will be required.

The program can now be stored with the SAVE command, or entered from tape into the memory with the LOAD command. It does not always work reliably and often requires a fair amount of experimentation with record and volume levels but once mastered, is essential for the serious user of the ZX81.

## IN CONCLUSION

The final chapters of the manual go into the more serious aspects of programming, including using machine code (this is the language that the Z80A processor understands), PEEKing and POKEing and the organisation of the memory. But it still leaves you wanting for more information so as to fully exploit the capabilities of the ZX81.

I also feel that you will very soon be needing the services of the 16K RAM Pack and quite possibly, the ZX Printer so this is worth bearing in mind when considering buying. Overall, it is a very good starting point (and a very cheap one, too) and over a million users can't be a bad recommendation.

In so far as add-on extras go, it is probably one of the best computers served. With software houses offering programs on games, educational and business subjects and independent manufacturers supplying keyboards, extra memory, high resolution graphics and interfaces, the humble ZX81 could soon become the heart of a sophisticated system. □

# AL COMPUTER

BY G.P. HODGSON

THIS six-part series describes experiments interfaced to the 380Z microcomputer using the Analogue-to-Digital Converter described on page 559, but could easily be adapted for use with other such devices. The software will be given for each experiment.

All these experiments have, at some time or other, been demonstrated in the classroom in a teaching situation and have proved very successful. These are not simulations but actual experiments performed by the teacher or pupil.

The results clearly demonstrated the advantage of supporting difficult physical ideas with almost instant experimental results, rapidly analysed and plotted. Measurable physical quantities were no longer the dreary abstract graphs which have to be learned from book or blackboard, but they actually came alive on a v.d.u. as the experiment was being performed, thus enabling the teacher to concentrate more on physical principles and interpretation of results and then in a separate experimental session to concentrate on the practical aspects of any given experiment.

# COMPUTER AIDED EXPERIMENTS

## USING THE RM380Z MICROCOMPUTER

BY A. A. CHANERLEY B.Sc. M.Sc.

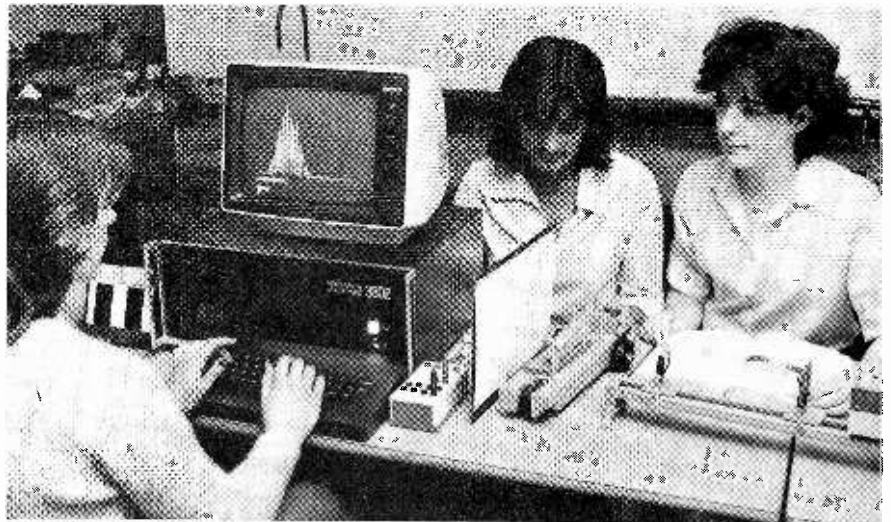

The experiment being carried out by lower sixth form pupils at La Retraite High School for Girls, London.

### 1. INVESTIGATION OF DIFFRACTION PATTERNS

THIS experiment employs the 380Z microcomputer to automatically store and plot the intensity distribution of the light pattern produced as a result of diffraction/interference from single and multiple slit light sources.

An optical sensor is made to scan the interference pattern produced and the resulting analogue electrical signal developed by this transducer is fed to an analogue-to-digital converter. We are using the unit described on page 559 in this experiment, although others could of course be used. The ADC is connected to the user port of the 380Z.

Under software control the digitised data is read in by the computer and the detected intensity pattern graphically displayed on the v.d.u. wired to the 380Z.

A monochromatic light source is required for this experiment which in this case is provided by a low power helium-neon laser. As can be seen in the photograph the laser sits on a special stand which also accommodates the slit(s) and a lens. The light pattern is observed on a vertical white screen.

#### OPTICAL SENSOR

An integrated optical transducer is used as the sensor. It contains a high efficiency photodiode combined with a high gain low noise amplifier. The internal circuitry for this electronic sensor is shown

in Fig. 1.1. It requires a split power supply of between  $\pm 2.5V$  and  $\pm 18V$  which is simply provided here by two PP1 6V batteries.

Under dark conditions there is zero output from the device. When light falls on the photodiode junction the output voltage rises, the level of the output being proportional to the intensity of the light received.

The connection details of this device are given in Fig. 1.2 where it is shown soldered to suitable lengths of plastic covered wire to be terminated in 4mm plugs to suit the specified ADC unit. Sleeving must be used, as shown, to prevent possible shorting of the pins.

Set up the experiment and connect the sensor to the ADC, and batteries, as shown in Fig. 1.3. Set the apparatus to produce a well defined image on the screen.

#### MOVING SENSOR

A means must be found for sweeping the sensor across the light beam. It can, and has successfully been carried out by hand, but a better method was found using the trolley normally found in the apparatus for velocity measurement. The sensor was fitted here, to the vertical metal mounting plate of a solderless breadboard system and held at the correct height with Blu-Tack. This

assembly was secured to the trolley which was then pushed at an even rate across the beam. This method was used to produce the double-slit interference pattern shown in Fig. 1.4.

The software for this experiment is shown opposite under LASER. The other routines STORE, POKER and GRAPH provide the facilities described in their respective REM statements.

SAVE "LASER" will copy the typed-in program onto disc and give it the filename LASER. LOAD "LASER" will transfer the LASER routine from disc to user RAM. These routines may also be saved/loaded on/from tape using the CSAVE and CLOAD commands respectively.

The six experiments are:

1. Investigation of diffraction patterns
2. Naphthalene cooling/heating curves
3. Voltage transfer characteristic of the bipolar transistor
4. Capacitor charge/discharge with variable time constant
5. Ohmic and non-ohmic resistances
6. I-V characteristic of a *pn*-junction

The theory behind this experiment is beyond the scope of EVERYDAY ELECTRONICS and readers requiring this information are referred to school and college text books on Physical Optics.

# COMPUTER AIDED EXPERIMENTS SOFTWARE: EXP. 1

## LASER

```

10 REM: this programme reads the light
20 REM: input from the A-to-D via the
30 REM: 380Z user port relocates the
40 REM: results and plots them.
50 GRAPHJ: GRAPHO
60 CALL "RESOLUTION", 0, 2: REM: HR-graphics
70 CALL "PLOT", 0, 0, 3
80 FOR I = 1 TO 300
90 POKE 64511, 0: REM: set channel.
100 Y=PEEK(64511): REM: read channel.
110 PLOT 70, 50, STR$(Y)+ " "
120 REM LIMITS OF SCREEN ARE 318, 191
130 CALL "LINE", I, Y*2, 3: REM: plot results
140 POKE(&6000+I), Y: REM: relocate results
150 FOR Z=1 TO 200: NEXT Z
160 NEXT I
170 PRINT "PRESS C TO CLEAR GRAPHICS"
180 G=GET()
190 IF G > 90 THEN G=G-32
200 IF G=67 THEN CALL "RESOLUTION", 0, 2

SAVE "LASER"

```

## STORE

```

10 REM: this programme stores the
20 REM: relocated data to disk file
30 CREATE#10, "LAS.DAT"
40 FOR V=&6000 TO (&6000+300)
50 BYTE=PEEK(V)
60 PRINT #10, V, ";", BYTE
70 NEXT V
80 CLOSE#10

SAVE "STORE"

```

## POKER

```

10 REM: this programme returns
20 REM: the data to memory
30 REM: locations for replotting.
40 OPEN#10, "LAS.DAT"
50 FOR V=&6000 TO (&6000+300)
60 INPUT#10, ADDR, BYTE
70 POKE ADDR, BYTE
80 NEXT V
90 CLOSE#10

SAVE "POKER"

```

## GRAPH

```

10 REM: this programme replots the
20 REM: data returned by the previous
30 REM: programme.
40 GRAPH 1
50 CALL "RESOLUTION", 0, 2
60 FOR I=2 TO 300
70 Y=PEEK(&6000+I)
80 CALL "LINE", I, Y*4, 3
90 NEXT I

SAVE "GRAPH"

```

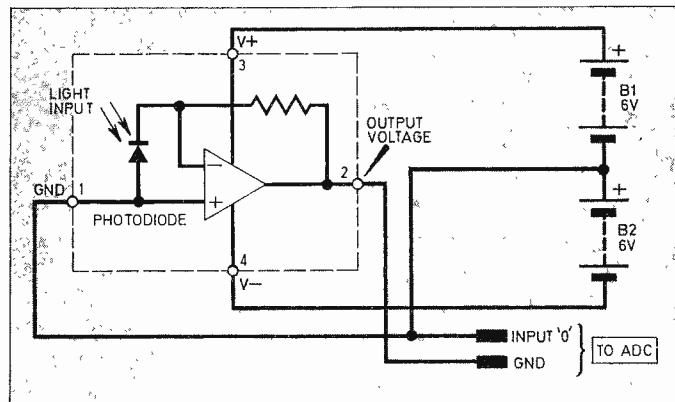

Fig. 1.1. Circuit diagram of the sensor and its battery power supply.

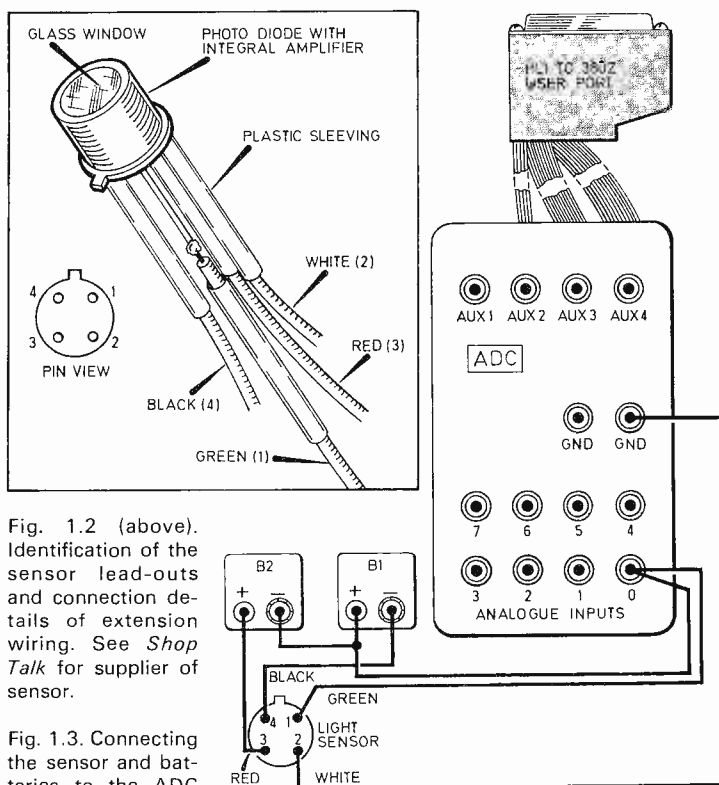
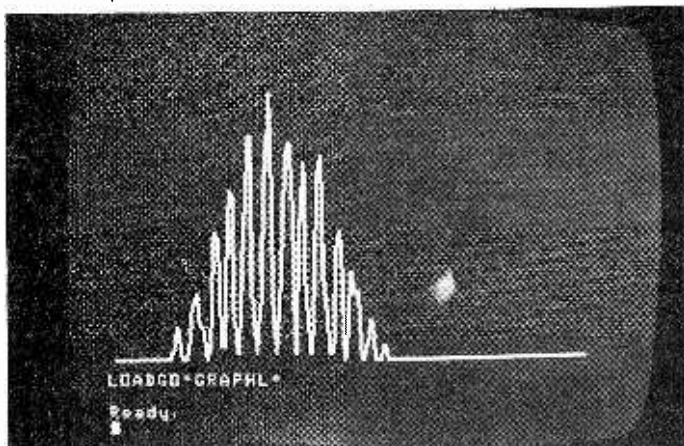

Fig. 1.2 (above). Identification of the sensor lead-outs and connection details of extension wiring. See *Shop Talk* for supplier of sensor.

Fig. 1.3. Connecting the sensor and batteries to the ADC unit.

Fig. 1.4. Photograph of a double-slit interference pattern obtained from an experiment.





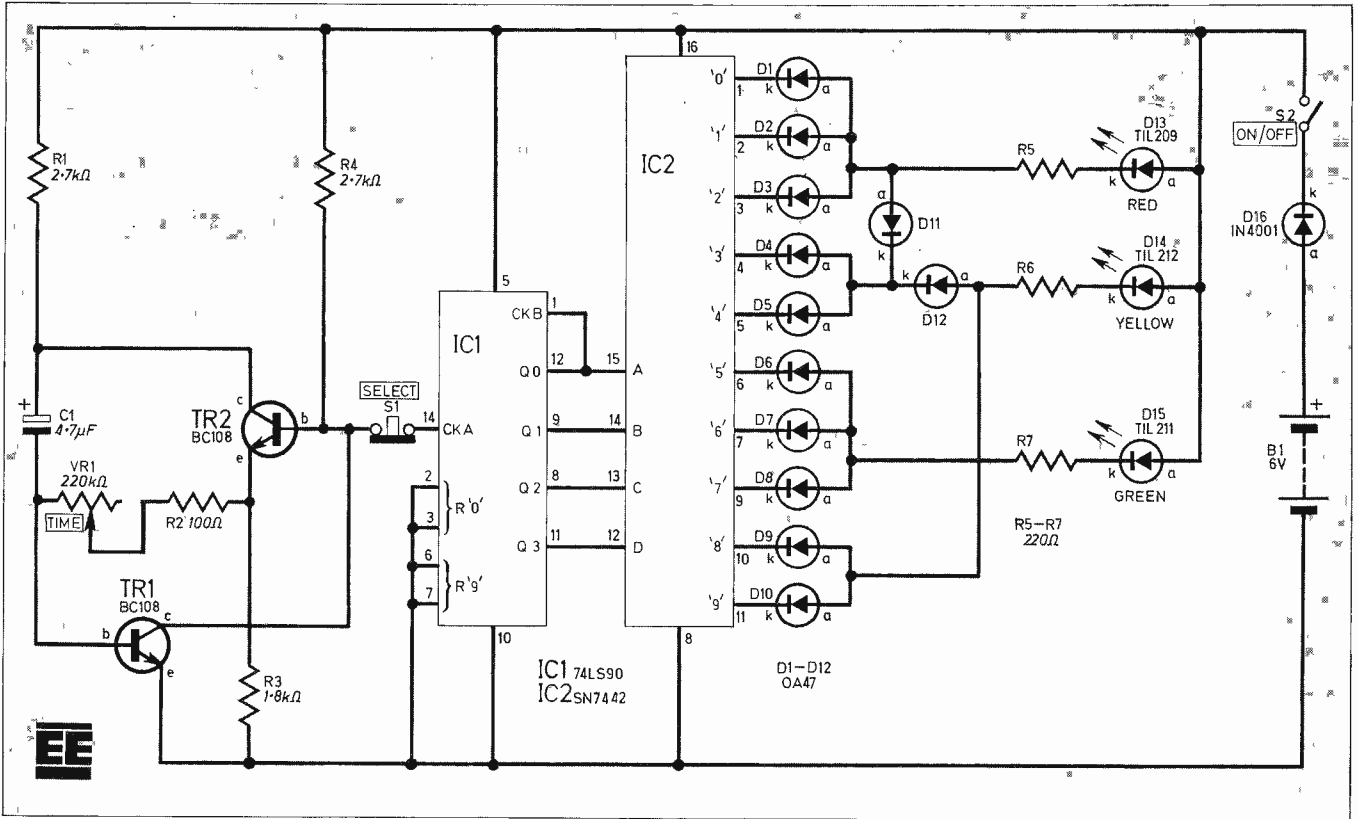

Fig. 1. The complete circuit diagram for the Traffic Light Simulator. A yellow light emitting diode (D14) is used for the "Amber" light sequencing. The circuit uses a low power TTL Schottky device (IC1) and the unit draws less than 40mA.

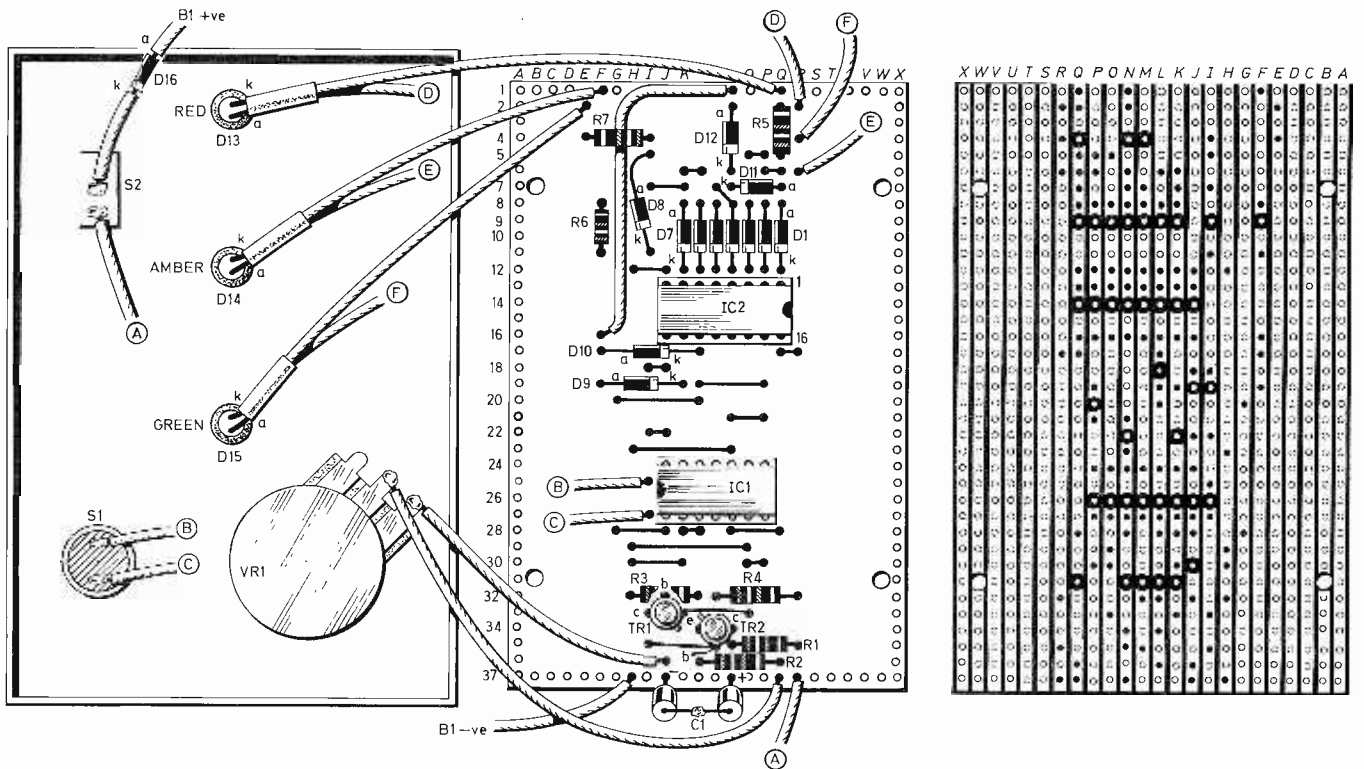

Fig. 2. Layout of components on the topside of the stripboard and interwiring to the front panel of the case. The underside of the board detailing breaks in the copper strips is shown far right.



## COMPONENTS

### Resistors

R1 4 2.7k $\Omega$  (2 off)  
 R2 100 $\Omega$   
 R3 1.8k $\Omega$   
 R5 6.7 220 $\Omega$  (3 off)  
 All  $\frac{1}{4}$ W carbon  $\pm$ 5%

See  
**Shop  
 Talk**  
 page 565

### Capacitor

C1 4.7 $\mu$ F 16V tantalum

### Semiconductors

D1-12 OA47 germanium (12 off)  
 D13 TIL209 0.12in red i.e.d.  
 D14 TIL212 0.12in yellow  
 i.e.d.  
 D15 TIL211 0.12in green i.e.d.  
 D16 1N4001 silicon  
 TR1,2 BC108 *npn* silicon (2 off)  
 IC1 74LS90 TTL low power  
 Schottky decade counter  
 IC2 7442 TTL b.c.d. to decimal  
 decoder

### Miscellaneous

VR1 220k $\Omega$  lin. control  
 potentiometer  
 B1 6V battery pack (HP7  $\times$  4)  
 S1 push-to-break  
 S2 single pole toggle  
 Stripboard: 0.1 inch matrix size  
 24 strips by 37 holes; aluminium  
 case, 102  $\times$  76  $\times$  38mm (AB8);  
 battery clip; connecting wire.

Approx. cost  
 Guidance only

**£8.00**

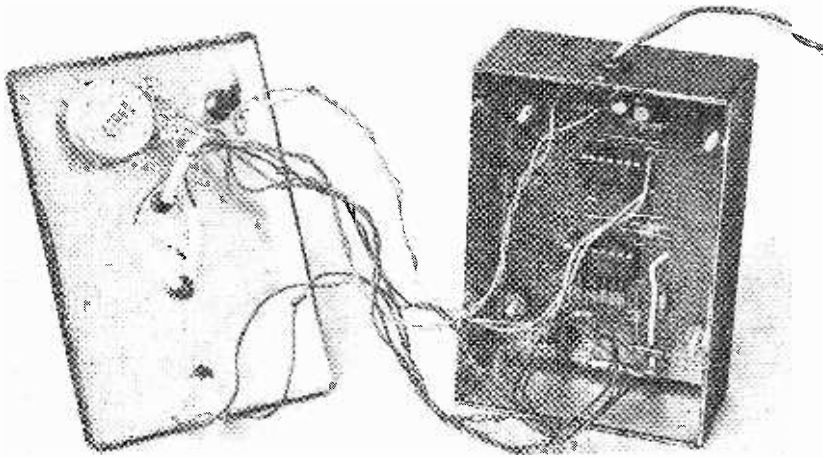

Completed unit showing circuit board mounted on spacers in the base of the case.

therefore rises and TR2 will now conduct. The capacitor then discharges through TR2, VR1 and R2, developing a diminishing voltage across VR1 and R2 which will hold TR1 off.

A voltage of opposite polarity, developed across R3 restarts the cycle by turning TR1 on again. The charging current of C1 continues the new cycle after TR2 (and therefore the initiating voltage) turns off. VR1 controls the frequency and R2 is simply a value high enough to sustain oscillation when VR1 is at a minimum.

## CONSTRUCTION

The prototype unit was constructed on a piece of 0.1 inch matrix stripboard, 24 strips by 37 holes, as shown in Fig. 2. It is

helpful to mount the i.c. holders first (after all track breaks have been made), these will then act as reference points for positioning the other components.

Attach sufficient lengths of flying leads to reach the i.e.d.s to be fitted to the lid of the case. Drill the lid of the case to accept the three i.e.d.s and fit these in position and hold secure with fixing clips. The two switches and VR1 may be fitted next.

## CASE

The prototype stripboard was mounted in a standard aluminium box having dimensions of 102  $\times$  76  $\times$  38mm. Although any case of similar dimensions should be suitable. Remember to take into account the size of a 6V battery pack when selecting the case.  $\square$

# BOOK REVIEWS

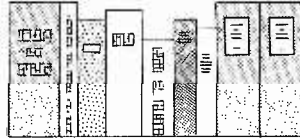

## OPERATIONAL AMPLIFIER EXPERIMENTAL MANUAL

**Author** G. B. Clayton  
**Price** £13.00 hard cover  
 £6.95 limp  
**Size** 220  $\times$  145mm. 130 pages  
**Publisher** Butterworth & Co. Ltd.  
**ISBN** 408 01240 4 (hard)  
 408 01239 0 (limp)

PRIMARILY intended as a companion to the authors text "Operational Amplifiers, 2nd Edition" (ISBN 0 408 000370 7), this manual can still stand alone as a guide to operational amplifier experiments for the serious student. It is designed to give the student a broad understanding of the practical applications of operational amplifiers.

A total of 21 different experiments are listed, ranging from basic resistive feedback configurations to complex phase-sensitive detector systems, each one using the same test board, the constructional details of which are given in the introduction.

An appendix suggests a method of using a personal computer to investigate op-amps.

As operational amplifiers are the most frequently used and versatile active devices in analogue electronics, an appreciation of their capabilities and limitations is essential for the designer.

G.P.H.

## PRACTICAL ELECTRONIC BUILDING BLOCKS BOOK 1 & BOOK 2

**Author** R. A. Penfold  
**Price** £1.95 Limp edition  
**Size** 180  $\times$  110mm. 94/110 pages  
**Publisher** Bernard Babant  
**ISBN** 0 85934 092 9 & 0 85934 093 7

ALL electronic circuits are built in various stages and contain a distinctive base circuit. Book 1 contains three chapters dealing with Oscillators, Monostable Multivibrators and Miscellaneous Circuits.

The basic building blocks for various electronic circuits are explained with the aid of good, clear diagrams.

A book that will provide the beginner to electronics with a good insight into circuit designs.

Book 2, a continuation of Practical Electronic Building Blocks Book 1, is designed to provide a number of useful electronic circuits with which a reader may build projects.

This book deals with circuits that process signals rather than generate them. The book contains three chapters, Amplifiers, Filters and Miscellaneous Circuits.

R.A.H.

# RADIO WORLD

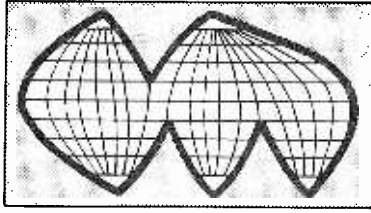

BY PAT HAWKER G3VA

## Political No-speak

Most radio amateurs are anxious to keep international politics firmly out of their hobby and like to think that freely talking to peoples of all nations plays a small but useful role in creating friendships across frontiers. But occasionally there are problems.

Several years ago, when the powerful Russian "woodpecker" radar was seriously affecting operations in some h.f. bands, a few amateur operators in North America made it clear that they would not contact amateur stations in the USSR until the interference-creating, over-the-horizon radar closed down. Most amateurs, however, recognised that no matter how much they disliked the woodpecker there was no hope that Russian amateurs would be able to influence their Defence ministries.

Indeed, the Russian amateurs were among those who suffered most from the woodpecker installations. It is as though we were to blame the Russian amateurs for the deliberate jamming of western h.f. broadcasts.

Then there was the period in the 1950s when, under the Stalin government, Russian amateurs were forbidden to talk to amateurs in western countries. A ban that disappeared early in the Khrushchev era.

Following an espionage scandal involving a serving member of the RAF, some restrictions were placed on the British Services amateur radio clubs. I am not sure to what extent these were ever enforced in seeking to limit contact with Eastern bloc stations.

My reasons for recalling these events is that it now seems that some East European amateurs have recently been declining to talk to amateurs in South Africa. Whatever one may think of a government, the idea of refusing to talk via amateur radio to its citizens seems totally against the traditions of a hobby that has always prided itself as constituting "a world-wide fellowship which knows no boundaries of race, class or creed".

## MASH Millions

The three big American commercial TV networks—ABC, CBS, NBC—are continuously locked in battle over the TV ratings. Particularly with the added requirement of being able to show that despite the growth of cable they can still attract larger audiences than ever.

In the current "all-time" list of the top ten television audiences (NTI household audience estimates) half of the programmes were transmitted in the first three

months of this year. On February 28 the final episode of MASH attracted an audience of over 50-million people for CBS, almost nine-million more than the previous best set by the "Who shot J.R.?" episode of Dallas in November 1980.

Four of the ten top audiences (No. 3, 4, 9, 10) were Super Bowl football games in 1983, 1982, 1980 and 1979. Part 8 of "Roots" (No. 5) gave ABC an audience of almost 36.4-million in 1977. Advertising time during Super Bowl matches can cost over £3800 per second.

## Museum of Television

A new National Museum of Photography, Film and Television has opened in Bradford, West Yorkshire, as the first phase of a £10-million project. At present the museum exhibits are devoted mainly to photography and film, but it is planned to set up a major television gallery in 1984-85.

The museum is closely associated with the Science Museum and has been funded jointly by the London Museum and Bradford Metropolitan Council. It includes a 340-seat theatre equipped to show 70mm, 35mm and 16mm film and there are also a number of computer-controlled multi-slide projectors.

Bradford seems to have stolen a march on Alexandra Palace where for several years there has been much talk of setting up a television museum in the part of the building (which escaped the fire a few years ago) that formed the original BBC high-definition TV studios in 1936.

In March this year three of the four episodes of "The Thorn Birds" mini-series gave ABC audiences of 35.4-million (Part 2), 35.99-million (Part 3) and 35.9-million (Part 4). Thorn Birds, not yet screened in the UK, is an American-made series lasting ten hours based on Colleen McCullough's novel about family life in the outback of Australia.

To obtain on three successive nights three places (6, 7 and 8) in the all-time "top ten" ratings is a remarkable achievement that suggests that in the face of cable competition American TV production is learning the lessons of the old Hollywood film epics. And those who dismiss so much American TV as rubbish should ponder on the fact that the intelligently-made MASH should have finished its long run on such a remarkably high peak, while "60 Minutes", a CBS weekly hard-hitting current affairs programme, figures prominently in the weekly "top ten" lists.

## Japanese No-code

Among the small but vocal minority of British enthusiasts who have been arguing in favour of amateur-radio h.f. licences free from the mandatory Morse test, Japan is frequently held up as an example of how international regulations can be circumscribed. The ITU's Radio Regulations insist on Morse proficiency below 50MHz but leave it to national authorities to decide if transmissions are unlikely to cause interference in other countries, and therefore escape the international rules.

For over a decade a codeless radio-telephone class licence permitting operation on h.f. bands (other than 14MHz) with a power output limit of 10 watts has been available in Japan. The result has been an enormous increase in the size of the domestic amateur radio market. Almost one million Japanese amateur operator licences have been issued: considerably more than the combined total of Europe and North America!

While this has undoubtedly enabled the Japanese communications industry to become the dominating force in the world market, the state of the hobby in Japan is less healthy than might appear from that one million figure.

## High Drop-Out Rate

In the first place in Japan, as in the USA, a distinction is made between an "operator" licence and a "station" licence. The Japanese "operator" licence is a lifetime issue. The number of Japanese "station" licences is just over half-a-million, of which about 95 per cent are the low-power "radiophone" licences.

There is a marked tendency for newcomers to lose all interest after about a year, with far less commitment to the hobby than in other countries arising from the limited value of the h.f. facility in view of the low-power of legal transmissions and the fantastic mutual interference. In effect, Japan turned its amateur radio licence into a substitute for a Citizens Band operation, though insisting that applicants receive some technical instruction.

The core of the Japanese amateur movement has thus remained with the small minority who have the higher grades of licence requiring a Morse test. Membership of the Japanese JARL national society has a very high drop-out rate, particularly among younger members, with new members being drawn increasingly from the over-30 age group.

Japan is now creating a new form of short-range "Personal Radio Service" on 903MHz with 79 simplex f.m. channels and a transmitter power of 5 watts. Perhaps an admission that you cannot combine CB and true amateur radio licences.

# VOLTAGE DUALISER

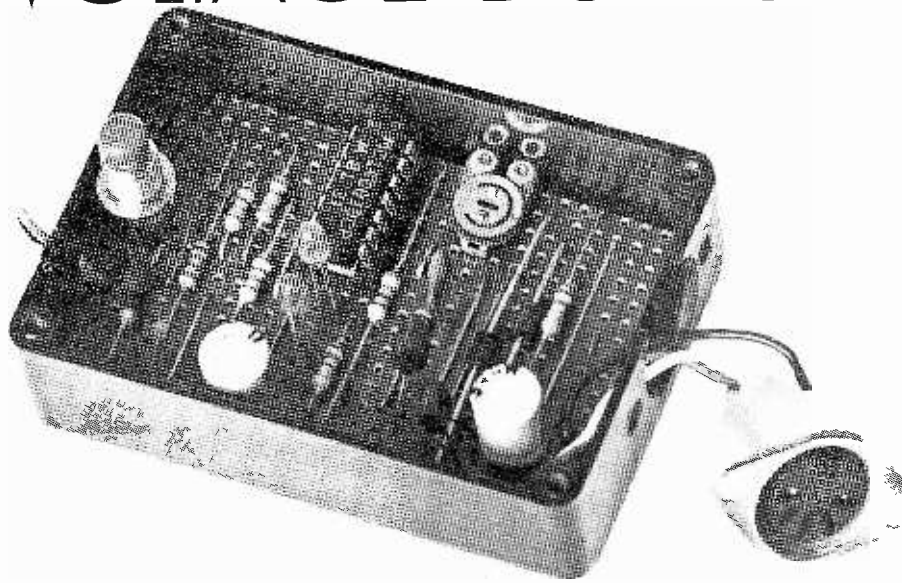

BY L.S. COOK

SOME electronic circuits demand a power source that will supply a positive and negative rail. In such a case, the circuit described here could be a useful extension to the existing power supply unit (p.s.u.), provided the latter can produce at least 135mA at 9V. The output from the Voltage Dualiser is approximately plus and minus 8V (or a total of 16V) at up to 60mA, the voltage varying a little with the current being drawn.

Electronic overload protection and indication have been incorporated into the design as a p.s.u. is unlikely to match the requirements in this respect.

Operational amplifiers frequently employ a dual supply, and voltmeter pre-amplifiers based on high input-impedance op-amps, are becoming increasingly important in view of the smaller currents encountered these days.

The Voltage Dualiser is not suitable for audio or radio frequency applications since the square-wave generated produces a high-pitched whistle at audio (and considerably more than that at radio) frequencies.

## CIRCUIT DESCRIPTION

The complete circuit diagram is shown in Fig. 1 and is essentially a form of

voltage doubler. When the switch (S1) is depressed momentarily, pins 2, 5 and 13 of IC1 are taken low causing IC1a and IC1b, with R2, R3 and C1 to produce a square-wave at pin 11 of IC1b.

This square-wave will then switch on TR2 and TR3, alternatively via buffers IC1c and IC1d thus steering current through l.e.d.s D1 (green) and D2 (red), and charging reservoir capacitors C2 and C3. When TR3 is off, l.e.d. D2 draws current from C2, similarly C3 supplies D1 when TR2 is switched off. Diodes D3 and D4 prevent C2 and C3 from discharging through TR2 and TR3 as well as isolating the source from the high voltage output.

With VR1 suitably set and no overloading the emitter-base potential of TR4 is sufficient to hold this transistor on and then a current is supplied from its collector to the base of TR1, via D1 which will become illuminated. TR1 is now held on. Pins 4 and 10 of IC1 are equipotential, so D2 does not illuminate.

## OVERLOAD

In the event of an overload, the output voltage drops, as does the emitter-base potential of TR4. The transistor TR4 and TR1 are then cut off and D1 is extinguished.

Pins 2, 5 and 13 of IC1 are taken high round the circuit resulting in the oscillator, TR2 and TR3 being switched off and D2 being illuminated. This means that pin 10 is now high and pin 4 is now low. The resistor R1 grounds the base of TR1 to stabilise this transistor.

## CONSTRUCTION

## CIRCUIT BOARD

All the components apart from SK1 are mounted on 0.1in matrix stripboard,

Fig. 1. Complete circuit diagram for the Voltage Dualiser.

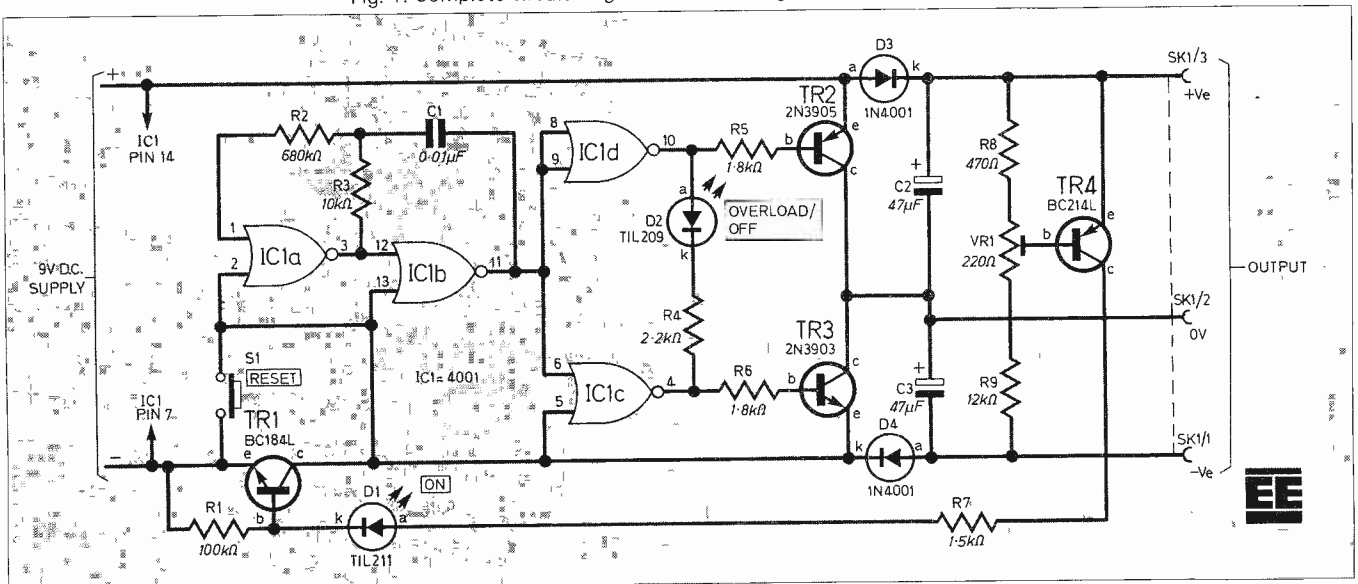

25 strips by 17 holes, as shown in Fig. 2. The first step is to make the 13 breaks in the copper tracks as shown.

The switch S1 is soldered directly to the stripboard making sure that it will project by a suitable amount through the lid of the case. The remaining components may now be soldered to the board. Thoroughly check the positioning of all the components, making sure that the polarities of C2 and C3 are correct.

Having soldered all the components to the board, the holes in the lid of the case for S1, D1 and D2 may be determined. No specific input connector is suggested as this will depend on individual needs.

## OUTPUT SOCKET

The output socket used in the prototype is a 3-pin DIN socket and is wired as shown in Fig. 2. It is not necessary to use this type of socket and may be left to personal choice.

The case chosen for this project was a Verobox measuring 72 x 50 x 24mm, although any box of similar size will be suitable.

## TESTING

Connect a 9V supply to the circuit and the red l.e.d. (D2) should light but then should extinguish, the green l.e.d. (D1) should now light up. The setting of VR1, to operate the cut-out at the appropriate point is quite critical and can be carried out by placing a 120 ohm resistor across one-half of the output (test each half in turn). Adjust VR1 so that the cut-out circuitry is just, and only just, activated. With a 150 ohm resistor similarly placed the unit should remain on.

Measure the output voltages for each half, they should each be about 1V below that of the supply, the drop occurring across the semiconductors. If further tests are needed the voltages at pins 4, 10 and

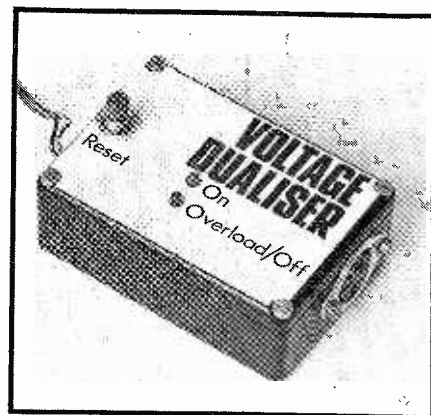

11 of IC1 can be measured. With the output on they should all register about 4 to 4.5V and with the output off, pin 10 should be at just under 9V and pins 4 and 11 at zero.

## COMPONENTS

### Resistors

H1	100kΩ
R2	680kΩ
R3	10kΩ
R4	2.2kΩ
R5,6	1.8kΩ (2 off)
R7	1.5kΩ
R8	470Ω
R9	12kΩ
All	1/4W carbon ±5%

See  
**Shop  
Talk**

page 565

### Capacitors

C1	0.01μF ceramic
C2,3	47μF 10V elect. radial leads (2 off)

### Semiconductors

D1	TIL211 3mm green l.e.d.
D2	TIL209 3mm red l.e.d.
D3,4	1N4001 silicon diode (2 off)
TR1	BC184L <i>nnp</i> silicon
TR2	2N3905 <i>npn</i> silicon
TR3	2N3903 <i>npn</i> silicon
TR4	BC214L <i>npn</i> silicon
IC1	4001B CMOS quad 2-input NOR gate

### Miscellaneous

S1	miniature push-to-make switch
VR1	220Ω lin. miniature horizontal preset
SK1	3-pin DIN socket
PL1	3-pin DIN plug

Stripboard, 0.1 inch matrix 25 strips by 17 holes; plastics box, 72 x 50 x 24mm (Verobox 202-21024B); 14-pin d.i.l. holder; 6BA nuts, screws and washers; tinned copper wire; 7/0.2mm connecting wire.

Approx. cost  
Guidance only **£6.00**

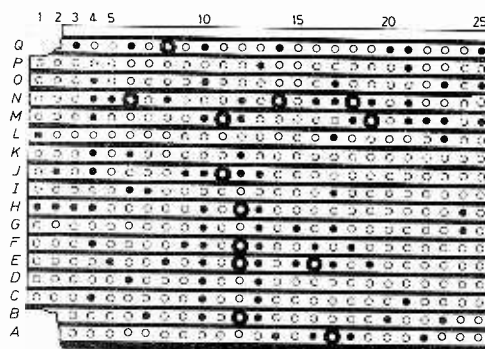
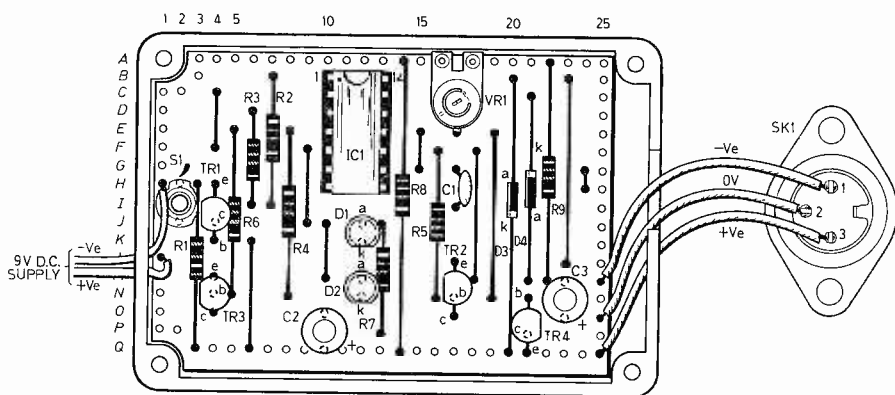
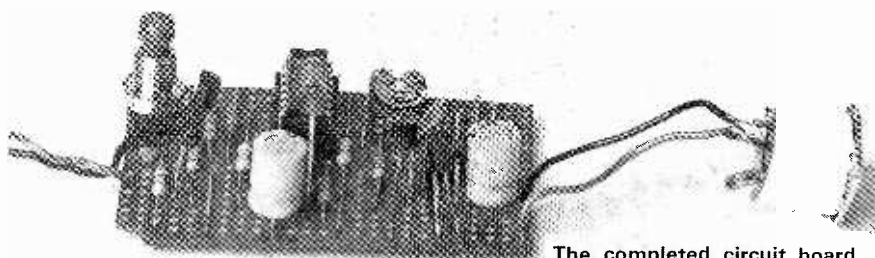

Fig. 2. The circuit board mounted in the case showing component layout and interwiring. (left): The underside of the stripboard detailing breaks in the copper tracks.



The completed circuit board with output leads wired to a DIN socket.

# LETTERS

## EE Excels

Sir—Many thanks for publishing my letter concerning the formation of the "National Electronics Correspondence Club". (See July issue.)

I have received a number of enquiries to date, entirely due to EVERYDAY ELECTRONICS and hope the response continues enabling me to contribute in a small way to the furtherance of the electronics hobby, as you are successfully doing in a larger way.

I wish you continued success with your publication, which, in my opinion excels to cover all of the various specialised subjects within electronics.

E. Foley,  
Levenshulme,  
Manchester.

## Exam Time

Sir—The Walsall Education Dept. have been operating courses to sit the Amateur Radio Exam No.765 at Barr Beacon School for several years.

The examination can be taken at the school in December, March and May, and the new enrolment starts 22 September at 7.00pm.

Those with adequate education in electrical theory may also sit the December and May exam. Courses are also provided for the beginner.

The teaching technique has been modified to suit CB enthusiasts who require more facilities.

F. A. Fear G8CVR,  
Aldridge,  
Walsall.

Sir—The Hendon College Science and Technology is offering a part-time evening course for persons wishing to take the City & Guilds 765 Radio Amateur's course.

Attendance is required on one evening per week for one year.

No special qualifications are required for admission since the course will start from basics, although candidates intending to take the examination in May 1984 will have a better chance of success if they possess some background in electricity.

Enrolment commences on 13 September at the Williams Building, The Burroughs, Hendon, NW4 4BT.

Chris Holford,  
Hendon,  
NW4 4BT.

Sir—No educational requirements nor is there an upper age limit for entrance to the Radio Amateurs Examination (R.A.E.) course being run by Brixton College for Further Education. The only requirement is an enthusiasm for Amateur Radio is essential.

Students attend for one evening a week from 6.30pm to 9.00pm. Students sit for the R.A.E. in the following May and the course then continues with a Morse class to the standard of the British Telecom Morse test.

Enrolment commences on 5 September at Brixton College, Ferndale Road, London, SW4 7SB.

R. McEwan Reid,  
Brixton,  
London.

## Resist-ance

Sir—I have two questions. First, I would like to know that when a speaker is said to be 50 ohms, does it mean that if an ohmmeter is connected across the speaker leads, it will read 50 ohms?

Secondly, how do you transfer a printed circuit board layout from the page to a piece of copper clad board? Your help will be highly appreciated.

E. Ali,  
Bahrain,  
Iran.

To answer your first enquiry, all loudspeaker specifications quote a nominal

input impedance. As a speaker contains a voice coil (that is, an inductive component) the impedance is not purely resistive and so varies considerably with frequency. A peak in the impedance occurs at the main bass resonant frequency of the speaker and the nominal quoted value of a speaker indicates the impedance at the first dip following this peak!

All this may sound a little complicated, but it is quite important when matching loudspeakers to high-quality hi fi amplifiers where the typical value is in the region of 8 ohms.

However, in the case of a 50-ohms speaker, the variation of the impedance due to the inductance of the coil will be far less and the d.c. resistance (that is, when measured with an ordinary ohmmeter) will be a good indication of the speaker impedance. So it is fairly safe to say that the ohmmeter put across the leads of a 50-ohms speaker will read about 50 ohms.

Your second enquiry requires a little more discussion. There are several methods of producing p.c.b.s from diagrams in EE. All current boards are available from the EE PCB Service but some constructors may wish to make their own.

In the UK, readers can purchase special kits, an example being the Electrolube CM100, to photographically reproduce the layout and transfer it to the copper. But these are expensive and I am unsure of the availability overseas.

A simple method is to lay the page over the copper clad board and mark the positions of all pad centres with a sharp point. This also helps to locate the drill when drilling the holes at a later stage. To avoid damaging the magazine pages, a photocopy of the layout can be used as the template.

The layout can then be carefully copied with an etch-resistant pen or dry-print transfers and crepe tapes. Alternatively, the track layout can be traced through using carbon paper and then the etch-resist applied. Before etching the board in ferric chloride, it is always wise to thoroughly check the layout as it is easier to take copper off than to put it back later!

# BOOK REVIEWS

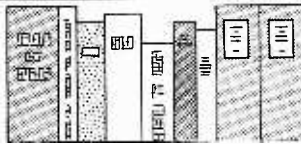

## ELECTRICAL INSTALLATION

**Authors** A. O. Akintante, J. M. Hyde  
**Price** £3.25 limp  
**Size** 210 x 260mm. 146 pages  
**Publisher** Macmillan Education Ltd.  
(Introduction to Technology series)  
**ISBN** 0 333 34680 7

FUNDAMENTALLY, Electrical Installation is a textbook providing a theoretical introduction, with practical applications, for students taking City and Guilds courses. It meets all the needs of the major examining boards and uses SI units, I.E.E. regulations and British Standards throughout.

Many students and apprentices in allied engineering disciplines or those just interested in the generation, supply and distribution of electrical energy should also find benefit in this

book. The text is presented in a clear and highly illustrated way and no previous knowledge is assumed. Examples and exercises from old exam papers are included in each section.

The nine sections cover subjects ranging from safety and workshop processes through transmission, distribution, wiring and earthing of electrical systems, to installation, maintenance and metering. The final chapter discusses contract planning and there is two appendices containing electric motor data. G.P.H.

## BASIC & PASCAL IN PARALLEL

**Author** S. J. Wainwright  
**Price** £1.50 Limp edition  
**Size** 180 x 110mm. 60 pages  
**Publisher** Bernard Babani  
**ISBN** 0 85934 101 1

AN unusual type of computer book which deals with the two computer languages, Basic and Pascal. The book takes the two languages and develops the idea of programming in both languages simultaneously.

The book contains eight chapters, the most useful being The Development of a Computer Program. Each new topic is easily explained, with program listings in both Basic and Pascal, so that program construction may be compared.

A useful book that will provide relative newcomers to computing with a useful program construction guide. R.A.H.



NEW · NEW · NEW · NEW  
**PRODUCTS**  
 NEW · NEW · NEW · NEW

## CLEANING STICK

A GLASS-FIBRE "stick", ideal for removing the protective coating found on the copper tracks of some p.c.b.s, is announced by Eraser International.

Available in both fine and coarse, the BR1 Fyberglass Cleaning Brushes are manufactured from pure spun glass and are also suitable for use on gold edge connectors, commutator cleaning and general oxidation removal.

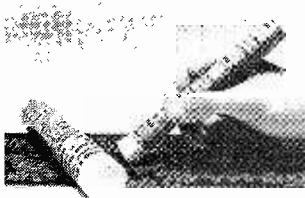

Further information can be obtained from:

*Eraser International Ltd.,  
 Dept EE, Unit M,  
 Portway Industrial Estate,  
 Andover, Hants SP10 3LU.*

## ELECTRONIC CONTROL SOLDERING IRON

A MAINS voltage electronically controlled temperature soldering iron has just been marketed by Light Soldering Development.

The EC50 incorporates an electronic temperature control circuit module mounted inside the handle. This operates in response to a thermistor fitted inside the bit-mount.

Power to the 50W heating element is controlled by a triac operated by a zero-voltage switching i.c., to minimise spiking and r.f.i. The iron is fully earthed so that it may safely be used on sensitive equipment and components.

A feature of the design is that the low voltage supply for the control module is obtained by means (for which a patent is pending) which does not involve fitting a dropper resistor in or near the handle. It is claimed that

this problem previously prevented a mains iron of this type being made to run with a sufficiently cool handle.

The control circuit provides a proportional control band, so that power to the heating element is only fully on or off outside a temperature band centred on a preset value. Within this proportional band, power supplied in regular pulses of equal interval but of a length which varies according to the difference between "actual" and "set" temperatures.

Access is provided to the temperature control potentiometer, and settings may be varied from approximately 280°C to 400°C. Standard setting is 370°C.

For details of prices and nearest stockists, write to:

*Light Soldering Developments Ltd.,  
 Dept EE, Spencer Place,  
 97/99 Gloucester Road,  
 Croydon, CR0 2DN.*

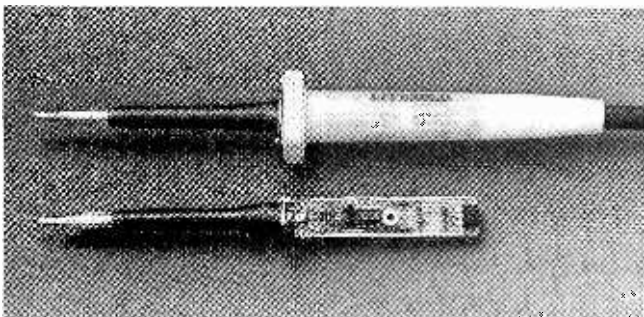

## MEMO PAD

A BRITISH designed electronic memo pad which can carry out the functions of a calendar, diary, address book, note pad and expense account log has been marketed in the UK by Domicrest Ltd. Called the Biztek Pad it will retail for £69.95.

Comprising a potential memory of 4000 characters, the Biztek Pad combines a 43-key keyboard with a large liquid crystal display with 16 alphanumeric characters, 20 numeric and clock digits and 45 special symbols.

When used as a conventional note pad, the unit will record messages consisting of words and/or figures in its internal memory and display them again on demand. For example, the fluctuations of a company's share

simply by keying in the first few characters of the person's name and pressing the recall button.

Appointments or personal engagements such as weddings, birthdays and anniversaries may be stored and by adding a date and a time, and utilising the alarm function, the pad can be programmed to sound the alarm at the appointed time. The necessary reminder can then be recalled to appear on the screen.

For the expense account log, the user keys in the relevant wording, enters the amount and presses the appropriate key to display one of the following: Auto, Entertainment, Hotel, Meal, Mileage, Phone or Travel.

Additional functions of the "memo pad" are a calculator, stopwatch and a permanent calendar and time display. A memory save switch ensures that

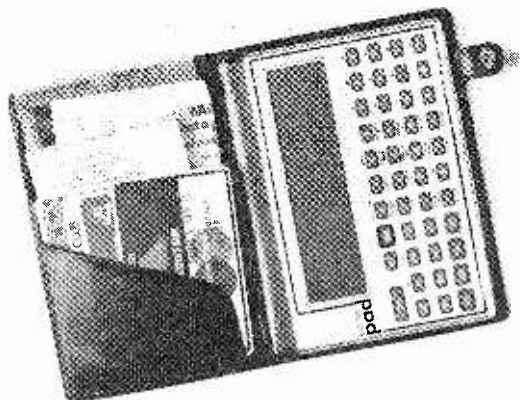

price, a shopping list or a cricket score card can be stored and recalled instantly.

As an address book it will store names and addresses and phone numbers which can be displayed

stored items are not "lost" when the batteries are changed.

*Domicrest Ltd.,  
 Dept. EE, Domicrest House,  
 31-37 Hoxton Street,  
 London, N1 6NJ.*

## HEAD TESTER

TWO video head testers have just been introduced to the Leader range of test equipment marketed by Thandar Electronics.

Designated LHC-909V (VHS) and LHC-909B (Beta), the tester will measure the amount of wear in video heads. Both units are priced at £45 plus VAT.

For more information and local stockist contact:

*Thandar Electronics Ltd.,  
 Dept EE, London Road,  
 St. Ives, Huntingdon,  
 Cambs PE17 4HJ.*

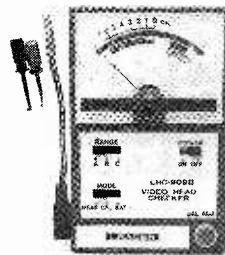



# CIRCUIT EXCHANGE

This is the spot where readers pass on to fellow enthusiasts useful and interesting circuits they have themselves devised. Payment is made for all circuits published in this feature. Contributions should be accompanied by a letter stating that the circuit idea offered is wholly or in significant part the original work of the sender and that it has not been offered for publication elsewhere.

## BLEEPER CIRCUIT

THIS circuit is simply two transistors TR1, TR2 switching each other on and off; but with the bleeper WD1 in circuit you do not notice this action as the capacitors C1, C2 keep the bleeper on until the power is pulsed to the opposite transistor.

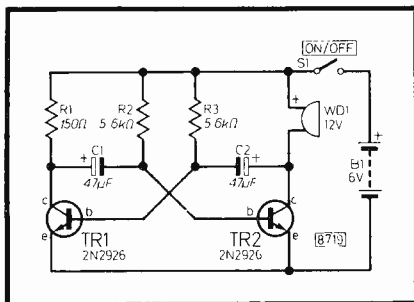

The transistors can be almost an *npn* silicon type like BFY51, 2N2926, BC108, BC107 and BC109. The circuit can work on 3–6 volts and the bleeper is a *Bleptone* 12V type. It can be used as a burglar alarm or a siren. (The bleeper tone can be changed by fitting a capacitor of a few hundred microfarads across the output to the bleeper.)

Martin Gill,  
Romford,  
Essex.

The thyristor now behaves like a common-place silicon diode. Even if the gate current is removed CSR1 will still remain on until the so-called "holding current" is reduced below a certain level. This can be attained by disconnecting the power supply (that is, a PP3 9V battery), using S1. The warning device used was a 6V solid state buzzer.

S. D. Stares,  
Totton,  
Hampshire.

## ALARM CIRCUIT

I HAVE designed a simple, but nevertheless, very effective alarm circuit based upon the operation of the thyristor or SCR. When the two probes "X" and "Y" are connected the gate of CSR1 is made positive with respect to the cathode, and this in turn switches it on.

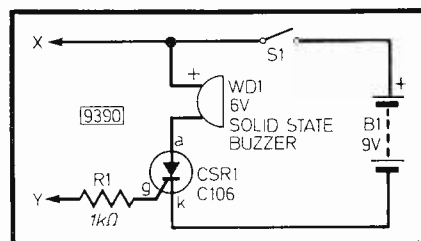

## JEE DISTRIBUTION LTD.

43 Strathville Road London SW18 4QX  
Tel: Sales 01-870 0075

BS9000 & CECC Approved

267 Hanworth Road Hounslow, Middx.  
Tel: 01-570 6502

### HOBBY KITS

	£ each
K2 Babyphone	5.85
K3 Stab. Power Supply	11.50
K4 Stereo Pre-Amp	8.90
K5 Stereo Amp 2×10W	12.50
K8 Stereo Pre-Amp with tone and vol. controls	11.40
K11 3W FM Transmitter	9.25
K14 Single Channel Receiver	12.50

### EAGLE MULTIMETERS

KEW 7N Analogue 2,000 opv	£5.25
EM10 Analogue 10,000 opv	£13.95
MM20 Analogue 20,000 opv	£21.95

### DIGITAL

TS 1,000 3½ Digit LED	£42.00
Logic Probe ELP 200	£19.95
Logic Probe EL 150	£11.95

### D.I.L. BREADBOARDS (Re-usable)

75 sq. cm. 550 sockets	each £5.70 BIM1
150 sq. cm. 1100 sockets	each £17.86 BIM2
Low cost Blob Boards 0.1" 120 mm centres, 10"×6" type 4V10	each £1.95

### MAINS TRANSFORMERS –6.0VA

0–4.5V : 0–4.5V wire-in	each £2.95
0–12V : 0–12V wire-in	
0–9V : 0–12V PCB	each £2.95
0–12V : 0–15V PCB	

P20C Post. all R. values	each 25p
Cermet Trimmers	each 20p
Control Knobs ¼" 0–9	each 45p
LED's with Panel Clips 3mm	18p
LED's with Panel Clips 5mm	25p
Soldering Iron EOW	each £16.45

### CAPACITORS

Electrolytic - Axial - Radial  
High Stability Polyeste. 001 to .47 μF  
Solid Tantalum Bead 0.1 to 100 μF  
Disc Ceramic Low Voltage

### RESISTORS

½ watt Carbon Film 5%  
½ watt Carbon Film 5%  
½ watt Metal Film 1%  
½ watt Metal Film 1%

### SEMI CONDUCTORS

Diodes, Transistors 1/C's  
Available from stock –  
FERRANTI, MULLARD, TEXAS,  
NATIONAL, SYGNETICS.

Visit or phone for a wide range of Electronic Components

## TECHNICAL TRAINING IN ELECTRONICS, TELEVISION AND AUDIO

### IN YOUR OWN HOME – AT YOUR PACE

ICS can provide the technical knowledge that is so essential to your success, knowledge that will enable you to take advantage of the many opportunities open to the trained man. You study in your own home, in your own time and at your own pace and if you are studying for an examination ICS guarantee coaching until you are successful!

### City & Guilds Certificates

#### Radio Amateurs

Basic Electronic Engineering (Joint C&G/ICS)

### Certificate Courses

TV and Audio Servicing  
Radio & Amplifier Construction  
Electronic Engineering\* and Maintenance  
Computer Engineering\* and Programming  
Microprocessor Engineering\*  
TV, Radio and Audio Engineering  
Electrical Engineering\* Installation  
and Contracting \*Quality for IET Associate Membership



Approved by CACC



Member of ABCC

### POST OR PHONE TODAY FOR FREE BOOKLET

Please send me your FREE School of Electronics Prospectus.

Subject of Interest \_\_\_\_\_

Name \_\_\_\_\_

Address \_\_\_\_\_

**ICS**

Post to: ICS  
Dept L629  
160 Stewarts Road,  
London SW8 4UJ



01-622 9911  
(All Hours)

**XK113 MW RADIO KIT**  
Based on ZN414 IC, kit includes PCB, wound aerial and crystal earpiece and all components to make a sensitive miniature radio. Size: 5.5 x 2.7 x 2cms. Requires PP3 9V battery. IDEAL FOR BEGINNERS. **£5.00**

**HOME LIGHTING KITS**

These kits contain all necessary components and full instructions & are designed to replace a standard wall switch and control up to 300w of lighting.

- TDR300K Remote Control Dimmer **£14.30**
- MK6 Transmitter for above **£ 4.20**
- TD300K Touchdimmer **£ 7.00**
- TS300K Touchswitch **£ 7.00**
- TDE/K Extension kit for 2-way switching for TD300K **£ 2.50**
- LD300K Rotary Controlled Dimmer **£ 3.50**



**THE JUPITER ACE MICROCOMPUTER**

**NOW available in stock**

uses FORTH which executes about 10 times faster and requires less program memory than a comparable program using basic. Features 8K ROM, 3K RAM, built in speaker, 40 key keyboard and a 32 x 24 line-flicker free display on TV. Comes supplied complete with leads, mains adaptor, a comprehensive easy-to-follow manual on Forth programming + FREE cassette containing 5 sample programs.

- JUPITER ACE SOFTWARE**
- J3 SPACE INVADERS **£3.90**
  - J4 SWAMP MONSTERS **£3.90**
  - J5 DOT MAN **£3.90**
  - J14 ASTRO & ELYTRAP **£4.35**

**ONLY £75.00** (+ £2.00 carriage + VAT)

- DRAGON 32** £143 + £7 carriage
- ORIC 1 (48K RAM)** £143 + £2.50 carriage

**COMPONENT PACKS**

- PACK 1 650 Resistors 47 ohm to 10 Mohm - 10 per value **£4.00**
- PACK 2 40 x 16V Electrolytic Capacitors 10µF to 1000µF - 5 per value **£3.25**
- PACK 3 60 Polyester Capacitors 0.01 to 1µF/250V - 5 per value **£5.55**
- PACK 4 45 Sub-miniature Presets 100 ohm to 1 Mohm - 5 per value **£2.90**
- PACK 5 30 Low Profile IC Sockets 8, 14 and 16 pin - 10 of each **£2.40**
- PACK 6 25 Red LEDs (5mm dia.) **£1.25**

**3-NOTE OOR CHIME**

Based on the SAB0600 IC the kit is supplied with all components, including loudspeaker, printed circuit board, a pre-drilled box (95 x 71 x 35mm) and full instructions. Requires only a PP3 9V battery and push-switch to complete. AN IDEAL PROJECT FOR BEGINNERS. Order as XK 102.

**£5.00**

**LCD 3 1/2 DIGIT MULTIMETER**  
16 ranges including DC voltage (200 mv-1000 v) and AC voltage, DC current (200 mA-10 A) and resistance (0-2 M) + NPN & PNP transistor gain and diode check. Input impedance 10M. Size 155x88x31 mm. Requires PP3 9v battery. Test leads included **ONLY £29.00**

**ELECTRONIC LOCK KIT XK101**

This KIT contains a purpose designed lock IC, 10-way keyboard, PCBs and all components to construct a Digital Lock, requiring a 4-key sequence to open and providing over 5000 different combinations. The open sequence may be easily changed by means of a pre-wired plug. Size: 7 x 6 x 3 cms. Supply: 5V to 15V d.c. at 40µA. Output: 750mA max. Hundreds of uses for doors and garages, car anti-theft device, electronic equipment, etc. Will drive most relays direct. Full instructions supplied. **ONLY £10.50**

Electric lock mechanisms for use with latch locks and above kit **£13.50**

**DISCO LIGHTING KITS**

**DL 1000K**  
This value-for-money kit features a bi-directional sequence, speed of sequence and frequency of direction change, being variable by means of potentiometers and incorporates a master dimming control. **£14.60**

**DLZ100K**  
A lower cost version of the above, featuring unidirectional channel sequence with speed variable by means of a pre-set pot. Outputs switched only at mains zero crossing points to reduce radio interference to a minimum. **Only £8.00**

Optional opto input DLA1 Allowing audio ("beat") -light response. **60p**

**DL3000K**  
This 3 channel sound to light kit features zero voltage switching, automatic level control & built in mic. No connections to speaker or amp required. No knobs to adjust - simply connect to mains supply & lamps. **Only £11.95**

**FREE GREEN CATALOGUE yet?**

Have you got your NO?! Send S.A.E. 6" x 9" TODAY!! It's packed with details of all our KITS plus large range of SEMICONDUCTORS including CMOS, LS TTL, linear, microprocessors and memories; full range of LEDs, capacitors, resistors, hardware, relays, switches etc. We also stock VERO and Antex products as well as books from Texas Instruments, Babani and Elektor.

**ALL AT VERY COMPETITIVE PRICES. ORDERING IS EVEN EASIER - JUST RING THE NUMBER YOU CAN'T FORGET FOR PRICES YOU CAN'T RESIST.**

**5-6-7 8-9-10** Answering service evngs & weekends

and give us your Access or Barclaycard No. or write enclosing cheque or postal order. Official orders accepted from schools, etc.

**OVM/ULTRA SENSITIVE THERMOMETER KIT**

This new design is based on the ICL7125 (a lower power version of the ICL7106 chip) and a 3 1/2 digit liquid crystal display. This kit will form the basis of a digital multimeter (only a few additional resistors and switches are required - details supplied), or a sensitive digital thermometer (-50°C to +150°C) reading to 0.1°C. The basic kit has a sensitivity of 200mV for a full scale reading, automatic polarity indication and an ultra low power requirement - giving a 2 year typical battery life from a standard 9V PP3 when used 8 hours a day, 7 days a week



**Price £15.50**

**FAST SERVICE · TOP QUALITY · LOW LOW PRICES**

**TK ELECTRONICS**  
11 Boston Road London W7 3SJ

Add 65p postage & packing +15% VAT to total Overseas Customers; Add £2.50 (Europe), £6.00 (elsewhere) for p&p Send S.A.E. for further STOCK DETAILS Goods by return subject to availability. 9am to 5pm (Mon to Fri) 10am to 4pm (Sat)

**ALL PRICES EXCLUDE VAT**

**OPEN** TEL: 01-567 8910 ORDERS 01-579 9794 ENQUIRIES 01-579 2842 TECHNICAL AFTER 3PM

**NORTHERN PRACTICAL WOODWORKING EXHIBITION**

Sponsored by Practical Woodworking Magazine  
Belle Vue, Manchester September 7-10, 1983  
September 7-9, 10am-7pm September 10 (Saturday) 10am-6pm

Features included in price of admission

- ★ Machinery and demonstrations for the woodworking enthusiasts and newcomers
- ★ Craft Market Place
- ★ A FREE Sotheby's valuation on your interesting wooden possessions
- ★ Major display of carving by T. H. Kendall

Admission prices: Adults £2.00  
Children under 16 and Senior Citizens £1.50  
Party rates: Adults £1.50 Children £1.00  
(Group of 20 or more \*Plus 1 free ticket for teacher or organiser).

For further information contact the Exhibition Manager, Northern Practical Woodworking Exhibition, Reed Exhibitions, Surrey House, 1 Throley Way, Sutton, Surrey SM1 4QQ.

See August and September issues of Practical Woodworking Magazine for 50p reduction voucher

**HOW DARE THEY!**

If you see an advertisement in the press, in print, on posters or a cinema commercial which makes you angry, write to us at the address below. (TV and radio commercials are dealt with by the I.B.A.)

The Advertising Standards Authority. If an advertisement is wrong, we're here to put it right. ASA Ltd, Brook House, Torrington Place, London WC1E 7HN

**TITAN TRANSFORMERS**  
DUNCOMBE STREET, GRIMSBY, SOUTH HUMBERSIDE DN32 7EG.

**INVERTERS**  
12/24 volt DC input from car battery to 240 volt AC output at 100, 250, 500 and 1000 VA. Plus, powerlift, autocharger, powersaver, powermonitor, autochangeover and battery isolator as optional extras.

**TRANSFORMERS**  
12/24 volt Range  
30/60 volt Range  
Autotransformers, safety isolating equipment P.C.B's etc.

**BATTERY CHARGERS** - 2 volt.

**ADAPTORS**  
6 volt to 7.5 volt to 9 volt switchable. 300MA regulated  
6 volt to 7.5 volt to 9 volt switchable. 250MA unregulated

Send SAE for prices and info. by return. Mail Order Prompt Service

# MASTER ELECTRONICS NOW! The PRACTICAL way!

YOUR CAREER..YOUR FUTURE..YOUR OWN BUSINESS..YOUR HOBBY  
THIS IS THE AGE — OF ELECTRONICS!  
the world's fastest growth industry...

There is a world wide demand for designers/engineers and for men to service and maintain all the electronic equipment on the market today — industrial — commercial and domestic. No unemployment in this walk of life!

Also — the most exciting of all hobbies — especially if you know the basic essentials of the subject. . . .

A few hours a week for less than a year — and the knowledge will be yours. . . .

We have had over 40 years of experience in training men and women successfully in this subject.

Our new style course will enable anyone to have a real understanding of electronics by a modern, practical and visual method. No previous knowledge is required, no maths, and an absolute minimum of theory.

You learn by the practical way in easy steps, mastering all the essentials of your hobby or to start, or further, a career in electronics or as a self-employed servicing engineer.

All the training can be carried out in the comfort of your own home and at your own pace. A tutor is available to whom you can write personally at any time, for advice or help during your work. A Certificate is given at the end of every course.

You will do the following:

- Build a modern oscilloscope
- Recognise and handle current electronic components
- Read, draw and understand circuit diagrams
- Carry out 40 experiments on basic electronic circuits used in modern equipment using the oscilloscope
- Build and use digital electronic circuits and current solid state 'chips'
- Learn how to test and service every type of electronic device used in industry and commerce today. Servicing of radio, T.V., Hi-Fi, VCR and microprocessor/computer equipment.



**British National Radio & Electronics School** Reading, Berks. RG1 1BR

**FREE!**

COLOUR BROCHURE



Please send your brochure without any obligation to

NAME \_\_\_\_\_

ADDRESS \_\_\_\_\_

\_\_\_\_\_

\_\_\_\_\_

I am interested in:

- COURSE IN ELECTRONICS as described above
- RADIO AMATEUR LICENCE
- MICROPROCESSORS
- OTHER SUBJECTS please state below

OR TELEPHONE US  
0734 51515 OR  
TELEX 22758  
(24 HR SERVICE)



BLOCK CAPS PLEASE

EE/9/841

POST NOW TO

**British National Radio & Electronics School** Reading, Berks. RG1 1BR



# Worth more than just a look in '83

1982 saw the first Electronic Hobbies Fair and immediately established itself as the foremost consumer electronics exhibition – the biggest attendance and the largest number of exhibitors.

The 1983 Fair will be bigger and even more exciting – offering visitors everything from resistors, I C's to home computers, transmitting and receiving units, and peripheral equipment, video games, musical instruments, radio control models. . . . In fact, whatever your particular electronic hobby you'll find this show will have something to excite you.

There will be plenty of other attractions too including radio and TV transmission; Robotics,

radio controlled models and demonstrations by local and national organisations. Again British Rail will be offering cheap-rate rail fares from all major stations in the country direct to the Alexandra Palace – a special bus will be waiting to ferry you direct to the show. Your ticket also includes admission to the Exhibition.

Alternatively, for those wishing to travel independently ticket prices at the door are £2.00 for Adults, £1.00 for children. Party rates are available on request (minimum 20 people).

For more information contact the Exhibition Manager, Electronic Hobbies Fair, Reed Exhibitions, Surrey House, 1 Throley Way, Sutton, Surrey SM1 4QQ. Tel: 01-643 8040.

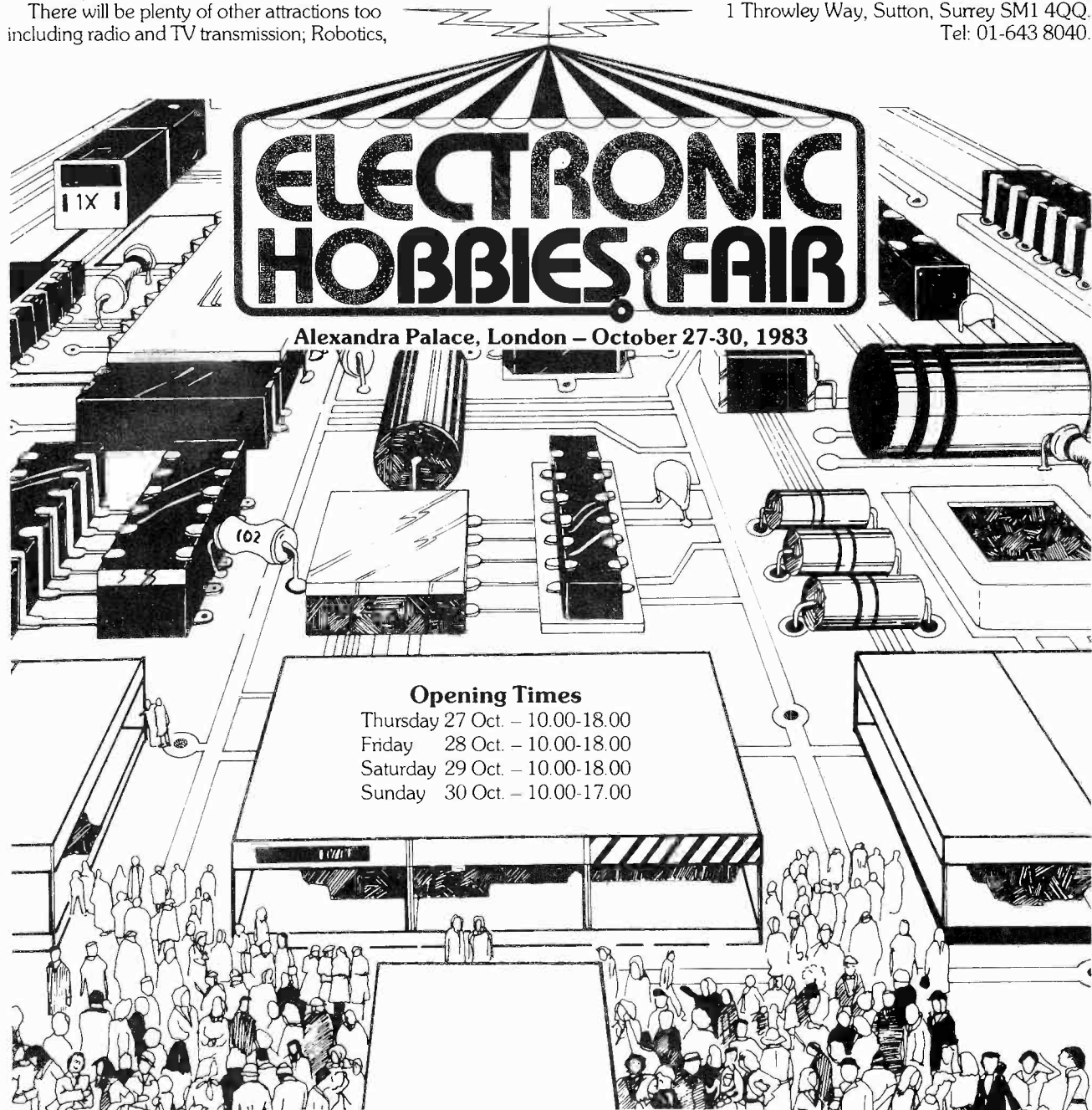

Alexandra Palace, London - October 27-30, 1983

### Opening Times

Thursday 27 Oct - 10.00-18.00  
Friday 28 Oct - 10.00-18.00  
Saturday 29 Oct - 10.00-18.00  
Sunday 30 Oct - 10.00-17.00

**Sponsored by Everyday Electronics, Practical Wireless and Practical Electronics**

Published approximately the third Friday of each month by IPC Magazines Ltd., Kings Reach Tower, Stamford St., London SE1 9LS. Printed in England by Chapel River Press, Andover, Hants. Sole Agents for Australia and New Zealand—Gordon and Gotch (A/Sia) Ltd. South Africa—Central News Agency Ltd. Subscriptions: Inland £12.00, Overseas £13.00 per annum payable to IPC Services, Oakfield House, Perrymount Road, Haywards Heath, Sussex. Everyday Electronics is sold subject to the following conditions namely that it shall not, without the written consent of the Publishers first given, be lent, resold, hired out or otherwise disposed of by way of Trade at more than the recommended selling price shown on cover, and that it shall not be lent, resold, or hired out or otherwise disposed of in a mutilated condition or in any unauthorised cover by way of Trade, or affixed to or as part of any publication or advertising, literary or pictorial matter whatsoever.

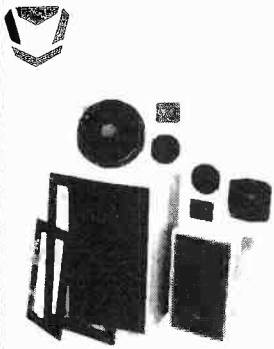

### MULLARD SPEAKER KITS

Purposely designed 40 watt R.M.S. and 30 watt R.M.S. 8 ohm speaker systems recently developed by MULLARD'S specialist team in Belgium. Kits comprise Mullard woofer (8" or 5") with foam surround and aluminium voice coil. Mullard 3" high power domed tweeter. B.K.E. built and tested crossover based on Mullard circuit, combining low loss components, glass fibre board and recessed loudspeaker terminals. **SUPERB SOUND AT LOW COST**. Kits supplied in polystyrene packs complete with instructions. 8" 40W system — recommended cabinet size 240 x 216 x 445mm. Price £14.90 each + £2.00 P & P. 5" 30W system — recommended cabinet size 160 x 175 x 295mm. Price £13.90 each + £1.50 P & P.

Designer approved flat pack cabinet kits, including grill fabric. Can be finished with iron on veneer or self adhesive vinyl etc. 8" system cabinet kit £8.00 each + £2.50 P & P. 5" system cabinet kit £7.00 each + £2.00 P & P.

### STEREO CASSETTE TAPE DECK MODULE

Comprising of a top panel and tape mechanism coupled to a record/play back printed board assembly. Supplied as one complete unit for horizontal installation into cabinet or console of own choice. These units are brand new, ready built and tested.

**Features:** Three digit tape counter. Autostop. Six piano type, record, rewind, fast forward, play and stop and eject. Automatic record level control. Main inputs plus secondary inputs for stereo microphones. Input Sensitivity: 100mV to 2V. Input Impedance: 8K. Output level: 400mV to both left and right hand channels. Output Impedance: 10K. Signal to noise ratio: 45dB. Wow and flutter: 0.1%. Power Supply requirements: 18V DC at 300mA. Connections: The left and right hand stereo inputs and outputs are via individual screened leads, all terminated with phone plugs (phone sockets provided). Dimensions: Top panel 5 1/2" x 11 1/2". Clearance required under top panel 2 1/2". Supplied complete with circuit diagram and connecting diagram. Attractive black and silver finish.

Price £26.70 + £2.50 postage and packing. Supplementary parts for 18V D.C. power supply (transformer, bridge rectifier and smoothing capacitor) £3.50.

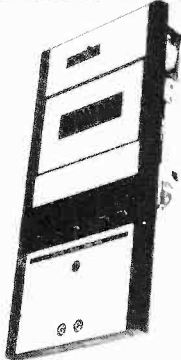

### LOUDSPEAKERS

THREE QUALITY POWER LOUD-SPEAKERS (15", 12" and 8". See Photo). Ideal for both Hi-Fi and Disco applications. All units have attractive cast aluminium (ground finish) fixing escutcheons. Specification and Prices.

15" 100 watt R.M.S. Impedance 8 ohms 50 oz. magnet 2" aluminium voice coil. Res. Freq. 20 Hz. Freq. Resp. to 2.5KHz. Sens. 97dB. Price £34.00 each + £3.00 P&P.  
12" 100 watt R.M.S. Impedance 8 ohms 50 oz. magnet 2" aluminium voice coil. Res. Freq. 25 Hz. Freq. Resp. to 4 KHz. Sens. 95dB. Price £24.50 each + £3.00 P&P.  
8" 50 watt R.M.S. Impedance 8 ohms 20 oz. magnet 1 1/2" aluminium voice coil. Res. Freq. 40 Hz. Freq. Resp. to 6 KHz. Sens. 92dB. Black Cone. Price: £9.50 each. Also available with black protective grille. Price: £9.99 each. P&P £1.50.

12" 85 watt R.M.S. MCKENZIE C1285GP (LEAD GUITAR, KEYBOARD, DISCO) 2" aluminium voice coil, aluminium centre dome, 8 ohm imp., Res. Freq. 45Hz., Freq. Resp. to 6.5KHz., Sens. 96dB. Price: £22.00 + £3 carriage.

12" 85 watt R.M.S. MCKENZIE C1285TC (P.A., DISCO) 2" aluminium voice coil. Twin cone, 8 ohm imp., Res. Freq. 45Hz., Freq. Resp. to 14KHz. Price £22 + £3 carriage.

15" 150 watt R.M.S. MCKENZIE C15 (BASS GUITAR, P.A.) 3" aluminium voice coil. Die cast chassis. 8 ohm imp., Res. Freq. 40Hz., Freq. Resp. to 4KHz. Price: £47 + £4 carriage.

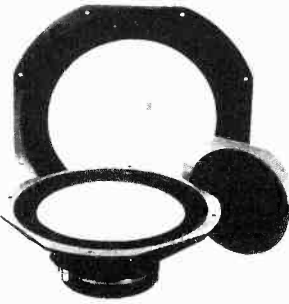

### OMP 80 LOUDSPEAKER

The very best in quality and value. Ported tuned cabinet in hard-wearing black vinylite with protective corners and carry handle. Built and tested, employing 10in British driver and Piezo tweeter. Spec: 80 watts RMS: 8 ohms: 45Hz-20KHz. Size: 20in x 15in x 12in. Weight: 30 pounds.

Price: £49.00 each  
£90 per pair  
Carriage: £5 each £7 per pair

### BK ELECTRONICS

Prompt Deliveries  
VAT inclusive  
prices  
Audio Equipment  
Test Equipment  
by  
Thandar  
and  
Leader

### PANTEC

HOBBY KITS. Proven designs including glass fibre printed circuit board and high quality components complete with instructions.

FM MICROTRANSMITTER (BUG) 90/105MHz with very sensitive microphone. Range 100/300 metres. 5 x 46 x 14mm (9 volt) Price: £7.99p

DIGITAL THERMOMETER -9.9 C to +99.9 C. LED display. Complete with sensor. 70 x 70 mm (9 volt) Price: £27.60p  
3 WATT FM TRANSMITTER 3 WATT 85/115MHz varicap controlled. professional performance. Range up to 3 miles 35 x 84 x 12 mm (12 volt) Price: £12.49p

SINGLE CHANNEL RADIO CONTROLLED TRANSMITTER/RECEIVER 27MHz Range up to 500 metres. Double coded modulation. Receiver output operates relay with 2amp/240 volt contacts. Ideal for many applications. Receiver 90 x 70 x 22 mm (9/12 volt) Price: £16.49 Transmitter 80 x 50 x 15 mm (9/12 volt) Price £10.29 P&P All Kits +50p. S.A.E. for complete list.



3 watt FM Transmitter

### BSR P256 TURNTABLE

P256 turntable chassis • S shaped tone arm • Belt driven • Aluminium platter • Precision calibrated counter balance • Anti-skate (bias device) • Damped cueing lever • 240 volt AC operation (Hz) • Cut out template supplied • Completely manual arm. This deck has a completely manual arm and is designed primarily for disco and studio use where all the advantages of a manual arm are required.

Price £31.35 each. £2.50 P&P

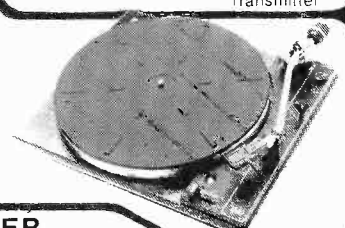

### OMP POWER AMPLIFIER MODULE

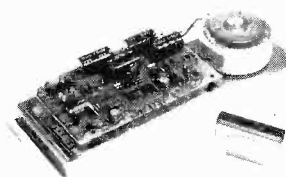

New model.  
Improved specification

NEW OMP100 Mk II POWER AMPLIFIER MODULE Power Amplifier Module complete with integral heat sink, toroidal transformer, power supply and glass fibre p.c.b. assembly. Incorporates drive circuit to power a compatible LED Vu meter. New improved specification makes this amplifier ideal for P.A., instrumental and Hi-Fi applications.

**SPECIFICATION**  
Output Power:— 110 watts R.M.S. Loads:— Open and short circuit proof 4/16 ohms. Frequency Response:— 15Hz - 30KHz -3dB. T.H.D.:— 0.01%. S.N.R. (Unweighted):— -118dB ±3.5dB. Sensitivity for Max Output:— 500mV @ 10K. Size:— 360 x 115 x 72 mm Price— £31.99 + £2.00 P&P. Vu Meter Price:— £7.00 + 50p P&P

OEM'S CONTACT BARRY PEARNE Tel. 0702 52752

### HOME PROTECTION SYSTEM

Better to be 'Alarmed' than terrified. Thandar's famous 'Minder' Burglar Alarm System. Superior microwave principle. Supplied as three units, complete with interconnection cable. **FULLY GUARANTEED.**

**Control Unit** — Houses microwave radar unit, range up to 15 metres adjustable by sensitivity control. Three position, key operated facia switch — off — test — armed. 30 second exit and entry delay.

**Indoor alarm** — Electronic swept freq. siren. 100dB output.

**Outdoor Alarm** — Electronic swept freq. siren. 98dB output. Housed in a tamper-proof heavy duty metal case.

Both the control unit and outdoor alarm contain rechargeable batteries which provide full protection during mains failure. Power requirement 200/260 Volt AC 50/60Hz. Expandable with door sensors, panic buttons etc. Complete with instructions.

SAVE £128 Usual price £228.85  
BKE's PRICE £99.p&p£4

S.A.E. for colour brochure.



SAFGAN DT-520 DUAL TRACE OSCILLOSCOPE. New British model. 12 month guarantee. 20 MHz Band Width. Specification: \* CH1, CH2 5mV/div 20V/div \* Time Base: 1 Sec/div 100ns/div \* XY Facility. Matched XY inputs \* Trigger Level control ± slope selection \* Auto normal, TV Triggering \* Z Modulation \* CAL out put 1V 1KHz \* Sweep output 0.9V \* Graticule blue led 10 x 8 cm (5" C.R.T.) Very sharp trace. \* Size: H235mm, W177mm, D360mm \* Weight: 6.5 Kgs \* Supply: 200-240 V. 40-60Hz. \* Price: £241.50 — FREE Secunior Delivery Probes. X1 £8.05. X1/X10 Switched £10.93

FREE SECUNIOR DELIVERY



### PIEZO ELECTRIC TWEETERS MOTOROLA

Join the Piezo revolution. The low dynamic mass (no voice coil) of a Piezo tweeter produces an improved transient response with a lower distortion level than ordinary dynamic tweeters. As a crossover is not required these units can be added to existing speaker systems of up to 100 watts (more if 2 put in series). **FREE EXPLANATORY LEAFLETS SUPPLIED WITH EACH TWEETER.**

TYPE 'A' (KSN2036A) 3" round with protective wire mesh, ideal for bookshelf and medium sized Hi-Fi speakers. Price £4.29 each.

TYPE 'B' (KSN1005A) 3 1/2" super horn. For general purpose speakers, disco and P.A. systems etc. Price £4.99 each.

TYPE 'C' (KSN6016A) 2" x 5" wide dispersion horn. For quality Hi-Fi systems and quality discos etc. Price £5.99 each.

TYPE 'D' (KSN1025A) 2" x 6" wide dispersion horn. Upper frequency response retained extending down to mid range (2KHz). Suitable for high quality Hi-Fi systems and quality discos. Price £7.99 each.

TYPE 'E' (KSN1038A) 3 1/2" horn tweeter with attractive silver finish trim. Suitable for Hi-Fi monitor systems etc. Price £4.99 each.

TYPE 'F' (KSN1057A) Cased version of type 'E'. Free standing satellite tweeter. Perfect add on tweeter for conventional loudspeaker systems. Price £10.75 each. P&P 20p ea. (or SAE for Piezo leaflets).

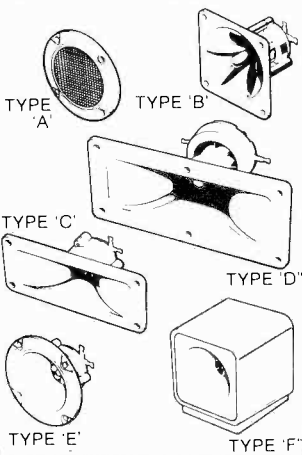

# B.K. ELECTRONICS

UNIT 5, COMET WAY, SOUTHEND-ON-SEA, ESSEX, SS2 6TR

★ SAE for current lists. ★ Official orders welcome. ★ All prices include VAT. ★ Sales Counter. ★ All items packed where applicable in special energy absorbing PU foam. ★ Please phone 0702 52752 ★

# MAKE ALL THE RIGHT CONNECTIONS

with a **MAPLIN MODEM KIT**

Exchange programs with friends, leave or read messages from the various Billboard services, talk to computer bureaux, or place orders and check stock levels on Maplin's Cashtel service. A Maplin Modem will bring a whole new world to your computer and vastly increase its potential.

Now you can exchange data with any other computer using a 300 baud European standard (CCITT) modem and because the Maplin Modem uses this standard, you could talk to any one of tens of thousands of existing users.

Some computers need an interface and we have kits for the ZX81, VIC20/Commodore 64, Dragon and shortly Spectrum and Atari, whilst the BBC needs only a short program which is listed in Projects Book 8.

A Maplin Modem will add a new dimension to your hobby.

Order As **LW99H (Modem Kit) excluding case. Price £39.95.**  
**YK62S (Modem Case). Price £9.95.**

Full construction details in *Projects Book 5*.



## Maplin's Fantastic Projects

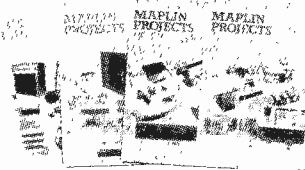

Full details in our project books. Price 70p each.

In **Book 1 (XA01B)** 120W rms MOSFET Combo-Amplifier ● Universal Timer with 18 program times and 4 outputs ● Temperature Gauge ● Six Vero Projects.

In **Book 2 (XA02C)** Home Security System ● Train Controller for 14 trains on one circuit ● Stopwatch with multiple modes ● Miles-per-Gallon Meter.

In **Book 3 (XA03D)** ZX81 Keyboard with electronics ● Stereo 25W MOSFET Amplifier ● Doppler Radar Intruder Detector ● Remote Control for Train Controller.

In **Book 4 (XA04E)** Telephone Exchange for 16 extensions ● Frequency Counter 10Hz to 600 MHz ● Ultrasonic Intruder Detector ● I/O Port for ZX81 ● Car Burglar Alarm ●

Remote Control for 25W Stereo Amp.

In **Book 5 (XA05F)** Modem to European standard ● 100W 240V AC Inverter ● Sounds Generator for ZX81 ● Central Heating Controller ● Panic Button for Home Security System ● Model Train Projects ● Timer for External Sounder.

In **Book 6 (XA06G)** Speech Synthesiser for ZX81 & VIC20 ● Module to Bridge two of our MOSFET amps to make a 350W Amp ● ZX81 Sound on your TV ● Scratch Filter ● Damp Meter ● Four Simple Projects.

In **Book 7 (XA07H)** Modem (RS232) Interface for ZX81/VIC20 ● Digital Enlarger Timer/Controller ● DXers Audio Processor ● Sweep Oscillator ● CMOS Crystal Calibrator.

In **Book 8\* (XA08J)** Modem (RS232) Interface for Dragon ● VIC Extenderboard ● Synchime ● Electronic Lock ● Minilab Power Supply ● Logic Probe ● Doorbell for the Deaf.

\*Projects for Book 8 were in an advanced state at the time of writing, but contents may change prior to publication (due 13th August 1983).

## NEW MAPLIN STORE OPENS IN MANCHESTER

Our new Manchester store offering the full range of Maplin's electronic components, computers and software will be opening 16th August, 1983. Part of the new store will be a self-service area where you can browse around and choose the parts you want. Counter service will be available as well. Upstairs you will find our computer demonstration area with displays of hundreds and hundreds of different software packages for Atari, BBC, Commodore 64, Dragon, Sord M5, Spectrum and VIC20.

You will find us at 8, Oxford Road opposite the BBC, between Piccadilly and the University complex. We're just a few steps from



Manchester's Oxford Road station and about five minutes walk from the city centre. There is excellent parking on meters in the adjacent side roads and we're about five minutes drive straight in from junction 10 on the M63 at the start of the M56.

Call in and see us soon!

## Great Projects From E&MM

Our new book "Best of E&MM Projects Vol. 1" brings together 21 fascinating and novel projects from E&MM's first year.

Projects include Harmony Generator, Guitar Tuner, Hexadrum, Syntom, Auto Swell, Partylite, Car Aerial Booster, MOS-FET Amp and other musical, hi-fi and car projects.

Order As **XH61R. Price £1.**

## ★ 1983 CATALOGUE ★

Over 390 pages packed with data and pictures and all completely revised and including over 1000 new items. On sale in all branches

of W.H. Smith. Price £1.25. Or send £1.50 (including p&p) to our mail-order address.



## LEARN ROBOTICS

- with *Hero 1*; the new robot who sees, hears, speaks and detects movement!

This remarkable microprocessor-controlled robot is the perfect robotics training system for industry, home and schools. Hero 1 can see, hear, speak, detect moving and stationary objects and determine their distance, pick up small objects, move in any direction and can learn from your instructions.

Hero 1 is a superbly documented Heathkit kit.

Order As **HK20W (Robot Kit) Price £1,599.95.**

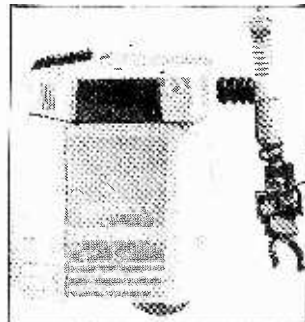

**MAPLIN**  
ELECTRONIC SUPPLIES LTD

Mail Order, P.O. Box 3, Rayleigh, Essex S66 8LR, Tel: Southend-on-Sea (0702) 552311.  
Shops at: 159-161 King Street, Hammanmith, London W5. Tel: 01-748 0926.

284 London Road, Westcliff-on-Sea, Essex. Tel: (0702) 554000.

Lyndon Square, Perry Barr, Birmingham. Tel: 021 356 7292.

8 Oxford Road, Manchester. Tel: 061 236 0291 (Opens 16th Aug. 1983)

All shops closed Mondays.

All prices include VAT & carriage. Please add 50p handling charge if total order value is under £5.