

WINTER EDITION

\$1.25

1975

POPULAR
ELECTRONICS

ELECTRONIC EXPERIMENTER'S HANDBOOK

HOW TO BUILD:

- 1-Digit Electronic Clock
- Anti-Mildew Ventilator
- Antenna Tuner for SWL's
- Auto Dwell/Tachometer
- Direct-Reading
Capacitance Meter
- Hi-Fi Automatic Switch
- Rechargeable Flashlight
- COSMOS Illuminated Die
- Keyless Vehicle Alarm
- Alpha Brain Wave Monitor
- Electronic Wind Chimes
- 3-Channel Color Organ

ALL WITH COMPLETE PLANS

PLUS...

- Fuses for Electronics
- Special Workbench Tools
- Model Rocketry for
Experimenters

A SCIENCE FAIR PROJECT

*Check your
Psi Quotient
with this*

ESP TESTER!



BUILD & TEST CIRCUITS AS FAST AS YOU THINK!

NEW Proto Board

Breadboard Assemblies

- Saves time
- Prevents expensive mistakes
- No soldering or patch cords
- Interconnect components with #22 solid hook-up wire
- 6 Models to choose from!

Each has one or more 5-way binding posts

Aluminum base is perfect ground plane and solid surface

All are compatible with digital/linear ICs, in TO5s, DIP packs and discrete components

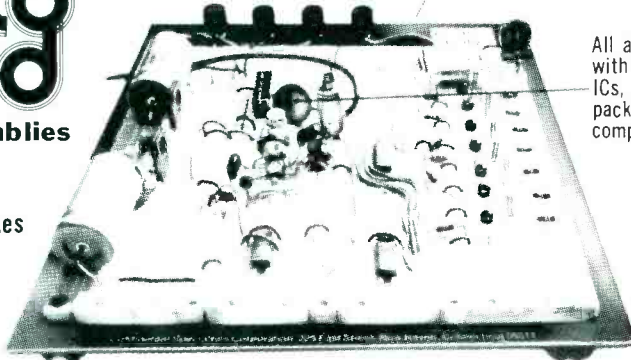

Rubber feet prevent scratching

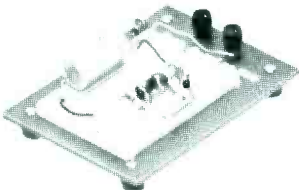

Proto Board 100. 10 IC capacity breadboard kit, includes all components down to nuts, bolts, screws and instructions.

19⁹⁵

Proto Board 203. Built-in regulated short-proof 5V, 1-AMP power supply. 2 extra floating 5-way binding posts. 24-14 pin DIP capacity. 9 3/4" long x 6 1/2" wide x 2 3/4" high. All metal construction.

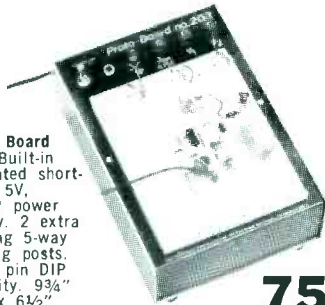

75.

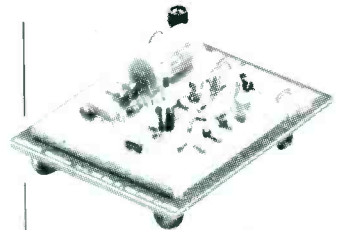

Proto Board 101. 10-14 pin DIP capacity. 5.8" long x 4.5" wide.

29⁹⁵



39⁹⁵

Proto Board 102. Compact 12-14 pin DIP capacity. 7" long x 4 1/2" wide.

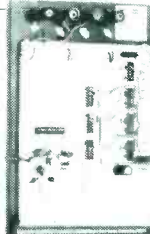

Proto Board 103. 2,250 solderless ground points. (4) 5-way binding posts. 24-14 pin DIP capacity. 9" long x 6" wide.

59⁹⁵

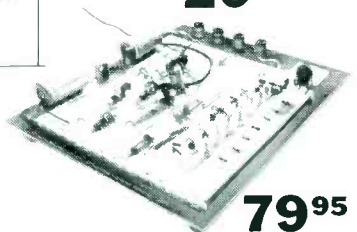

Proto Board 104. 3,060 solderless tie points. (4) 5-way binding posts. 32-14 pin DIP capacity. 9 1/2" long x 8" wide.

79⁹⁵

ORDER TODAY! Available at local distributors or directly from CSC. Send for FREE selection guide with applications, photos, specs and more. Phone charges accepted on BankAmericard, Master Charge, American Express. Dealer inquiries invited.



Continental Specialties Corporation

44 Kendall Street, New Haven, CT 06512

Telephone: (203) 624-3103

CANADA: Available thru Len Finkler, Ltd., Ontario

CIRCLE NO. 1 ON READER SERVICE CARD

**You get the same 25"
DIAGONAL
hobby-kit color TV from
three different schools.**

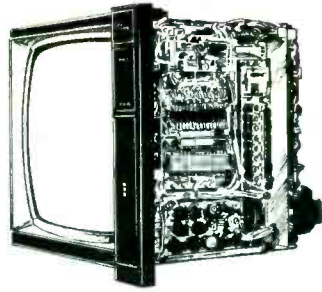

**You get
this designed-
for-learning
25" color TV
DIAGONAL
only with NRI training.**

No other home-study school gives a TV like the one you build with NRI's Master Course in Color TV/Audio Servicing. At least three give you a hobby kit bought from outside sources, not even originally designed to train people for TV servicing. So their lessons and experiments are "retro-fitted" to the set as it comes.

There's only one way a student can (1) get the feel of commercial circuitry, (2) learn bench techniques while building a set from the "ground" up, (3) do over 25 "in-set" experiments, and (4) end up with a solid-state TV with wood-grain cabinet and all the modern features for top performance. And that's by learning on a set engineered from the beginning to give this combination of advantages, the exclusive NRI 25" diagonal color TV.

NRI passes the savings on to you

This unique TV doesn't cost you more . . . it costs you less. Because NRI eliminates the middle man. No



outside sources for TV kits, no salesman's commission. We sell by mail only. We pass along the savings in the form of lower tuition fees, exclusive extras like a console TV cabinet and a solid-state table radio, and complete instruments. You get professional triggered sweep oscilloscope, TV pattern generator, digital multimeter, and more. There are courses costing \$800 more than ours that don't even give as much.

More know-how per dollar

What counts is the quality of training you get for the money you spend. In our 60-year history, almost a million students have come to NRI. We're fully approved for the G.I. Bill. So we must be teaching something right.

Like designing "bite-size" lessons to ease understanding and speed learning . . . personally grading tests . . . a full-time staff of engineer/instructors . . . "real-life" kits and experiments . . . and programs oriented to full or part-time professional careers.

Widest choice of career opportunities

NRI offers five TV/Audio Servicing courses so you can tailor your training to your budget. Or you can study opportunity fields like Computer Electronics, Mobile Radio, Communications, and others. Send for our free catalog with full descriptions, lesson plans, and career futures. No obligation, no salesman will call. See for yourself why NRI experience, selection, and exclusives give you something no other school can.

MAIL CARD FOR FREE CATALOG
No salesman will call.

If card is missing, write to:



NRI SCHOOLS
McGraw-Hill Continuing Education Center
3939 Wisconsin Avenue,
Washington, D.C. 20016

1975 **ELECTRONIC** POPULAR **EXPERIMENTER'S** **ELECTRONICS** **HANDBOOK**

WINTER EDITION

COLOR CODE CHARTS	7
CHECK YOUR PSI QUOTIENT WITH THIS ESP TESTER	9
<i>You can run sophisticated scientific experiments or just use the machine as a party ice-breaker.</i>	
DIFFERENTIAL-TEMPERATURE BASEMENT VENTILATOR	17
A WHEATSTONE-BRIDGE SUBSTITUTION BOX	20
SOLDER & SOLDERING	25
PRECISION LAB POWER SUPPLY	28
ADJUSTING YOUR TV SET FOR BEST COLOR	33
REFLEX ENCLOSURE DIMENSIONS	36
BUILD A PINK NOISE GENERATOR	37
DESIGN YOUR OWN VOLTAGE REGULATOR	40
LOW-COST CONVERGENCE GENERATOR	41
SOLID-STATE CIRCUITS FOR THE EXPERIMENTER	48
SWITCHING LOGIC QUIZ	52
WHAT MAKES THE TRANSISTOR TICK?	53
PRACTICAL EXPANDED-SCALE MILLIOHMETER	57
A X10/X100 INSTRUMENT SENSITIVITY BOOSTER	61
BUILD A RECHARGEABLE FLASHLIGHT	66
AN ALPHA BRAIN WAVE FEEDBACK MONITOR	70
<i>You may be able to learn to relax—through electronics—by inducing an "alpha state."</i>	
SPECIAL TOOLS FOR THE ELECTRONICS WORKBENCH	76
MODEL ROCKETRY	80
BUILD A 175-MHz PRESCALER	85
BUILD AN ENLARGER TIMER	88

TRONIC EXPERIMENTER'S HANDBOOK: Published semi-annually by Ziff-Davis Publishing Company
Park Avenue, New York, New York 10016. William Ziff, President; Hershel B. Sarbin, Senior Vice President
Secretary, and Treasurer; Philip Sine, Senior Vice President.
Copyright © 1974 by ZIFF-DAVIS PUBLISHING COMPANY. All rights reserved.

FLASH TUBES: OPERATION & APPLICATIONS	Richard M. Fisher	90
STAGE LIGHTING FOR THE AMATEUR	Steven E. Margison	93
LOW-COST ELECTRONIC THERMOMETER	James R. Squires	96
FUSES FOR ELECTRONICS	Bussman Mfg. Div.	97
THE HOW AND WHY OF THE SCR	Joseph H. Wujek	103
BUILD THE MONODIGICHRON	Michael S. Robbins	107
	<i>An electronic clock that uses one-digit readout and displays hours/minutes in sequential form.</i>	
AUTOMATIC AMPLIFIER SWITCH	Tommy N. Tyler	112
ELECTRONIC CIRCUIT ANALOGY QUIZ	Robert P. Balin	114
ELECTRONIC WIND CHIMES	John S. Simonton Jr.	115
SIMPLE COMPRESSOR-EXPANDER	Craig Anderton	120
DIRECT-READING CAPACITANCE METER	Dale Hileman	121
	<i>Measures from 15 pF to 10 μF in five ranges—plus useful options to 100 μF.</i>	
A PREAMPLIFIER FOR YOUR SCOPE	Imre Gorgenyi	125
BUILD A LIGHT PROBE	Forrest Mims	128
ANTENNA TUNER FOR SWL's	Carl C. Drumeller	130
DWELL/TACHOMETER INSTRUMENT	Edward N.J. Marguerit	131
VERSATILE IC TIMER	Walter W. Schopp	136
BUILD THE DECID-O-TRON	Lewis J. Newmire	138
VEHICLE ALARM SYSTEM	Frank J. Di Elsi	141
DESIGN YOUR OWN COLOR ORGAN	Daryl Slaviero	144
BUILD A COSMOS DIE	Michael S. Robbins	146
	<i>You can work with COSMOS units, learn a lot, yet play games with this "six-sided die."</i>	
SINGLE-FILAMENT TAIL LIGHT CONVERTER	Marvin Beier	149
TEST YOUR SEMICONDUCTOR KNOWLEDGE	William R. Shippee	150

Cover Photo: Conrad Studios
 For details on how to build the
 "ESP Tester," see page 9.

The Publisher has no knowledge of any proprietary rights which will be violated by the making or using of any items disclosed in this Handbook.

EDGAR W. HOPPER, *Publisher*

ARTHUR P. SALSBERG, *Editorial Director* ● **STANLEY NEUFELD**, *Assoc. Publisher*

P. B. HOEFER, *Managing Editor* ● **EDWARD I. BUXBAUM**, *Art Director*

JOSEPH E. HALLORAN, *Adv. Director* ● **JOHN J. CORTON**, *Adv. Sales*

ANDRE DUZANT, *Technical Illustrator* ● **LINDA BLUM**, *Adv. Service Mgr.*

FURMAN H. HEBB, *Group Vice President, Electronics & Photographic*

1975 POPULAR ELECTRONIC EXPERIMENTER'S HANDBOOK

WINTER EDITION

Ziff-Davis Publishing Company
William Ziff
President

W. Bradford Briggs
Executive Vice President

Hershel B. Sarbin
Senior Vice President
Secretary and Treasurer

Philip Sine
Senior Vice President

Phillip T. Heffernan
Vice President, Marketing

Frank Pomerantz
Vice President, Creative Services

Arthur W. Butzow
Vice President, Production

Edward D. Muhlfeld
Vice President, Sports Division

George Morrissey
Vice President

Sydney H. Rogers
Vice President

Sidney Holtz
Vice President

Lawrence Sporn
Vice President, Circulation

Edgar W. Hopper
Vice President, Electronics Division

Jerry Schneider
Vice President & Administrative
Director, Annuals

Ziff-Davis Publishing Company
Editorial, Circulation, and Executive Offices
One Park Avenue, New York, New York 10016
212 725-3500

Midwestern Office
The Pattis Group
4761 W. Touhy Ave., Lincolnwood, Ill. 60644
312 679-1100

Gerald E. Wolfe, George B. Mannion

Western Office
9025 Wilshire Blvd., Beverly Hills, Calif. 90211
213 273-8050, BR 2-1161
Western Adv. Manager, Bud Dean

Japan
James Yagi, Oji Palace Aoyama
6-25, Minami Aoyama, 6-Chome, Minato-ku
Tokyo 407-1930/6821



1975 ELECTRONIC EXPERIMENTER'S HANDBOOK is published semi-annually by the Ziff-Davis Publishing Company, One Park Avenue, New York, N.Y. 10016. Also publishers of Stereo Review, Popular Electronics, Communications Handbook, Tape Recording, & Buying Guide and Stereo Directory & Buying Guide

LEDS

-MV10B Visible red SPECIAL	5 for \$1.00
-MV50 type red emitting	6 for 1.00
-MAN 3 type	\$1.45 ea.—3 or more 1.00
-MAN 4 type	2.25 ea.—3 or more 2.00

TTL

7400-S .23	7451-.27	74157-1.55	8000 SERIES
7401-.23	7453-.27	74161-1.65	
7402-.23	7454-.40	74163-2.50	
7403-.23	7470-.45	74164-2.50	8090-S .35
7404-.25	7472-.41	74165-2.50	8091-.55
7405-.24	7473-.47	74166-1.75	8092-.55
7406-.50	7474-.47	74170-3.00	8093-.55
7407-.50	7475-.90	74173-1.75	8094-.55
7408-.25	7476-.47	74176-.85	8095-.55
7409-.25	7480-.50	74177-.85	8096-.55
7410-.23	7482-1.75	74180-1.05	8097-.55
7411-.90	7483-1.15	74181-3.75	8098-.55
7413-.89	7484-1.10	74182-1.00	8121-.90
7416-.45	7486-.47	74190-1.50	8123-1.60
7417-.45	7488-3.00	74192-1.80	8130-2.25
7418-.25	7490-1.00	74193-1.50	8200-2.70
7420-.23	7491-1.15	74194-1.50	8210-3.25
7421-.27	7492-.95	74195-1.05	8214-1.60
7423-.32	7493-.95	74199-2.75	8220-1.60
7425-.27	7494-.97		8280-.75
7426-.31	7495-.95		8288-.90
7427-.32	7496-.95		
7429-.40	74100-1.50		
7430-.33	74107-.47		
7432-.26	74121-.95		
7437-.45	74122-.47		
7438-.34	74127-1.05		
7440-.27	74125-.60		
7441-1.10	74126-.90		
7442-1.05	74141-1.15		
7443-1.10	74145-1.15		
7444-1.15	74150-.95		
7445-1.10	74151-1.20		
7446-1.25	74153-1.80		
7447-1.25	74154-1.20		
7448-1.25	75155-1.30		
7450-.25	74156-1.30		

CD 4001-.65 8520-1.20

CD 4002-.65 8551-1.75

CD 4009-1.50 8554-2.70

CD 4010-.65 8570-1.00

CD 4011-.65 8600-.85

CD 4013-.65 8810-.75

CD 4012-.65 8812-1.10

CD 4013-1.60 8820-1.50

CD 4015-1.50 8822-2.70

CD 4023-.65 8830-.60

CD 4025-.65 8831-2.70

CD 4027-1.35 8832-2.70

CD 4030-.65 8836-.60

CD 4030-.65 8837-1.50

CD 4030-.70 8838-1.50

CD 4030-.65 8880-1.35

SPECIALS

7400-7401-7403-7404-7410-7420	5 for \$1.00
R-2307CP Current-Controlled Oscillator	\$3.15
R-25K Waveform Generator Kit	\$28.00
R-1310P Stereo Demodulator	\$4.10
NE555V	\$1.00 each
NE556V	\$1.85 each
LM309K 5V 1A regulator	\$1.25 each
723 Regulator	\$1.50 each
741 operational Amp	\$.39 each
LM 311-comparators	\$1.00 each
NE 565 Phase Locked Loop	DIP OR TO-5 \$2.00 each
NE 566 Function Generator	MINI DIP OR TO-5 \$2.00 each
NE 567 Tone Decoder	MINI DIP OR TO-5 \$2.00 each
7489 64 bit RAM TTL	\$2.75 each
8223 Programmable ROM	\$4.50 each

LINEAR

LM300 Pos V Reg (super 723)	TO-5	\$.85
LM301 Hi performance AMPL	TO-5 or MINI DIP	.40
LM302 Voltage Follower	TO-5	.85
LM305 Positive Voltage Regulator	TO-5	1.00
LM307 Op AMP (super 741)	TO-5 or MINI-DIP	1.40
LM308 Micro Power Op Amp	TO-5 or MINI-DIP	1.15
LM309H 5V Regulator	TO-5	1.15
LM309K 5V 1A Regulator	TO-3	1.70
LM311 Hi perf. Voltage Comparator	TO-5 or MINI-DIP	1.15
LM380 2 Watt Audio AMPL	DIP	1.60
LM709 Operational AMPL	TO-5 or DIP	.40
LM711 Dual Differential Comparator	DIP	.39
LM723 Voltage Regulator	DIP	.65
LM739 Dual Hi Performance Op AMP	DIP	1.15
LM741 Comp. Op AMP	TO-5 or MINI-DIP	.55
LM747 Dual 741 Op AMP	TO-5 or DIP	.90
LM1458 Dual Comp. Op. Amp	MINI-DIP	.65
LM3900 Quad Amplifier	DIP	.65
LM7905 Precision Timer	MINI-DIP	.95
LM7524 Core Memory Sense AMPL	DIP	1.75
LM7525 Core Memory Sense AMPL	DIP	.90
LM7535 Core Memory Sense AMPL	DIP	.90
LM9601 Retriggerable One Shot	DIP	.75
LM75451 Dual Peripheral Driver	MINI-DIP	.49
LM75452 Dual Peripheral Driver	MINI-DIP	.49
LM75453 (LM351) Dual	MINI-DIP	.65
LM320K Minus 5, 12 or 24 V.V.R. TO-3		\$1.25

Satisfaction guaranteed. All items are fully tested.
\$5.00 minimum order. FIRST CLASS MAIL—NO EXTRA CHARGE
California residents—add 6% sales tax.
WHOLESALE OUTLETS—Write for special discounts.

JAMES

Electronics

P.O. Box 822 BELMONT, CA. 94002
(415) 592-8097

CIRCLE NO. 8 ON READER SERVICE CARD

COLOR CODE CHARTS

COLOR BAND SYSTEM

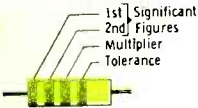

Resistors With Black Body Color Are Composition, Non-Insulated. Resistors With Colored Bodies Are Composition, Insulated. Wire-Wound Resistors Have The 1st Digit Color Band Double Width.

RESISTOR CODES (RESISTANCE GIVEN IN OHMS)

COLOR	DIGIT	MULTIPLIER	TOLERANCE
BLACK	0	1	±20%
BROWN	1	10*	±1%
RED	2	100	±2%
ORANGE	3	1000	±3%*
YELLOW	4	10000	GMV**
GREEN	5	100000	±5% (EIA Alternate)
BLUE	6	1000000	±5%*
VIOLET	7	10000000	±12 1/2%*
GRAY	8	.01 (EIA Alternate)	±30%*
WHITE	9	.1 (EIA Alternate)	±10% (EIA Alternate)
GOLD		.1 (JAN and EIA Preferred)	±5% (JAN and EIA Preferred)
SILVER		.01 (JAN and EIA Preferred)	±10% (JAN and EIA Preferred)
NO COLOR			±20%

*GMV = guaranteed minimum value, or -0 - 100% tolerance.
 ±3, 6, 12 1/2, and 30% are ASA 40, 20, 10, and 5 step Tolerances.

BODY-END-DOT SYSTEM

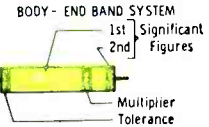

DISC CERAMICS (5-DOT SYSTEM)

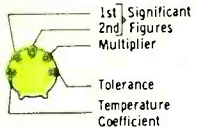

DISC CERAMICS (3-DOT SYSTEM)

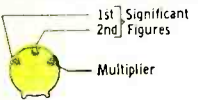

CERAMIC CAPACITOR CODES (CAPACITY GIVEN IN pF)

COLOR	DIGIT	MULTIPLIER	TOLERANCE		TEMPERATURE COEFFICIENT PPM/°C	EXTENDED RANGE SIGNIFICANT FIGURE	TEMP. COEFF. MULTIPLIER
			10 pF or LESS	OV 10MM			
BLACK	0	1	+2.0 pF	±20%	0(NP0)	0.0	-1
BROWN	1	10	+1.0 pF	±1%	-33(N033)		-100
RED	2	100		±2%	-75(N075)	1.0	-100
ORANGE	3	1000		±2.5%	-150(N150)	1.5	-1000
YELLOW	4	10000			-220(N220)	2.2	-10000
GREEN	5		+0.5 pF	±5%	-330(N330)	3.3	-1
BLUE	6				-470(N470)	4.7	-10
VIOLET	7				-750(N750)	7.5	-100
GRAY	8	.01	+0.25 pF		-30(P030)	General	-1000
WHITE	9	.1	+1.0 pF	±10%	General		-10000
SILVER					Purpose Bypass & Coupling		
GOLD					+100 (P100, JAN)		

Voltage ratings are standard 500 volts for some manufacturers, but 1000 volts for other companies.

HIGH CAPACITY TUBULAR CERAMIC INSULATED OR NON-INSULATED

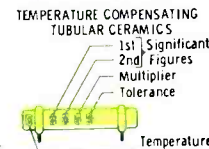
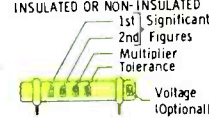

MOLDED-INSULATED AXIAL LEAD CERAMICS

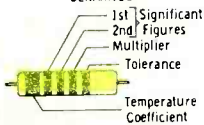

TYPOGRAPHICALLY MARKED CERAMICS

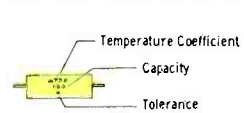

JAN LETTER	TOLERANCE	
	10 pF or LESS	OVER 10 pF
C	±0.2 pF	
D	±0.5 pF	
F	±1.0 pF	±1%
G		±2%
J		±5%
K		±10%
M		±20%

EXTENDED RANGE T.C. TUBULAR CERAMICS

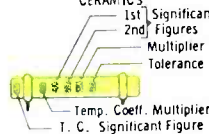

MOLDED CERAMICS

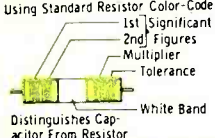

BUTTON CERAMICS

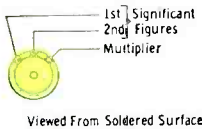

STAND-OFF CERAMICS

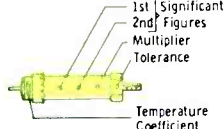

FEED-THRU CERAMICS

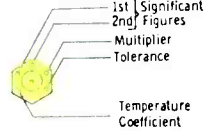

MOLDED MICA CAPACITOR CODES (Capacity Given In pF)

COLOR	DIGIT	MULTIPLIER	TOLERANCE	CLASS OR CHARACTERISTIC
BLACK	0	1	±20%	A
BROWN	1	10	±1%	B
RED	2	100	±2%	C
ORANGE	3	1000	±3%	D
YELLOW	4	10000		E
GREEN	5		5% (EIA)	F (JAN)
BLUE	6			G (JAN)
VIOLET	7			H (EIA)
GRAY	8			I (EIA)
WHITE	9			J (EIA)
GOLD		.1	5% (JAN)	
SILVER		.01	10%	

Class or characteristic denotes specifications of design involving Q factors, temperature coefficients, and production test requirements. All axial lead mica capacitors have a voltage rating of 300, 500, or 1000 volts, *or ±1 n pF whichever is greater.

MOLDED PAPER CAPACITOR CODES (Capacity Given In pF)

COLOR	DIGIT	MULTIPLIER	TOLERANCE
BLACK	0	1	±20%
BROWN	1	10	
RED	2	100	
ORANGE	3	1000	
YELLOW	4	10000	
GREEN	5	100000	5%
BLUE	6	1000000	
VIOLET	7		
GRAY	8		
WHITE	9		10%
GOLD			5%
SILVER			10%
NO COLOR			20%

MOLDED PAPER TUBULAR

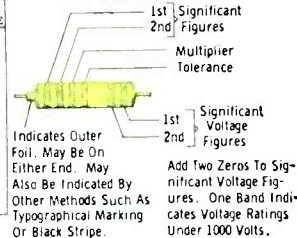

CURRENT STANDARD JAN AND EIA CODE

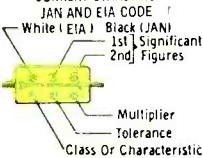

BUTTON SILVER MICA

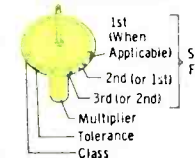

MOLDED FLAT PAPER CAPACITORS (COMMERCIAL CODE)

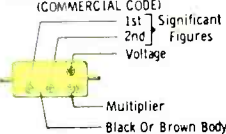

MOLDED FLAT PAPER CAPACITORS (JAN CODE)

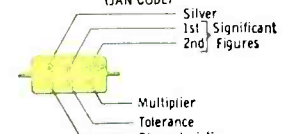

THE EASIEST MONEY YOU'LL EVER MAKE...BELIEVE IT OR NOT! IT'S TRUE

**"I MADE \$35,000 IN JUST 1 DAY
AT HOME IN BED WITH THE FLU"**

**By simply putting my successful money method
in action I'm making thousands of dollars
every week whether I work or not...**

**I WILL QUICKLY TEACH ANY MAN OR WOMAN
MY PROVEN "EASY MONEY SECRET" OF
STARTING FROM SCRATCH AND MAKING A
FORTUNE PRACTICALLY OVERNIGHT!**

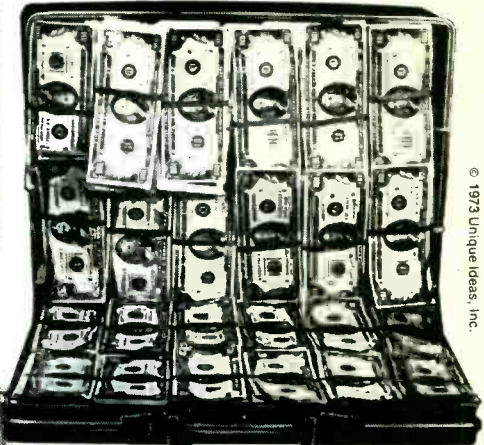

© 1973 Unique Ideas, Inc.

My briefcase crammed with thousands of dollars to be deposited in my bank.

**OFFICIAL PROOF OF RESULTS
CERTIFIED NOTORIZED AND DOCUMENTED
LEGAL SWORN AFFIDAVIT:**

TO WHOM IT MAY CONCERN:

As the Accountant for Unique Ideas, Inc., Mr. Ernie Tucker, Pres., I attest to the fact that he earned Thirty Five Thousand Dollars in a single day and presently averages in the thousands every week.

Personally I've always found him to be both a Successful and Honest Man. I certify that all of these statements are true.
Certified Public Accountant's Name Available upon Request.

Bank Reference: Chelsea National Bank Notary Public
825 Seventh Ave 1973
New York, N.Y. 10019 Harry Shalita Dec. 3

ONE HUNDRED DOLLARS

**AN HONEST NO NONSENSE WAY TO RICHES
IT ACTUALLY WORKS FOR YOU**

No equipment to buy or lease, no hustling your friends to buy junk merchandise and no books or correspondence course required.

**DEFINITELY NOT A CON GAME, FRANCHISE,
INVESTMENT SCHEME OR GIMMICK**

YOU DON'T NEED MONEY TO MAKE MONEY

Obviously you were not born rich so what? 85% of the men and women who are rich today started with very little money and had only average education, so why not be honest with yourself and stop using lame excuses, stand up and face the fact that the only real difference between you and thousands of rich Americans is that they discovered the right moves to make and you did not!

YOU GET RICH MAKING "THE RIGHT MOVES"

I've proven this to be true despite the fact that I was born poor and barely squeaked through high school. I still made a fortune in just a short period by making the right moves and I'll show you exactly how I did it.

But why am I so anxious to reveal to you my secret money making method? Surely there's more to it than because I enjoy helping others share in the rich good life as I have but frankly I expect to profit at least two hundred thousand dollars, maybe more, from the publishing of these ads in nationally famous magazines and newspapers.

STOP WASTING PRECIOUS YEARS

I should know, I wasted more good years than I care to remember, before I finally discovered the secret of making money. I stayed up to my neck in debt, bounced around from one eight hour dead end job to another. Just working, waiting and wishing for a great fortune to fall in my lap. I got married, became a proud father at a young age. I worked in a toy factory for a short time and peddled cosmetics from door to door, but everything I tried my hands at failed because I didn't know the right moves to make. This only happened to me twelve years ago. No doubt there are millions who are suffering this agonizing torment now.

REVEALING: THE RICH MAN'S SECRET MONEY MAKING METHOD

It's true that most rich persons keep

their money making secrets to themselves, seldom sharing it with others, but fortunately I met several unusually fair minded rich men who were so impressed with my ambition to get rich that they agreed to teach me the secret money making techniques that their many years of making millions had taught them, providing I would virtually work for them at least one year. I eagerly jumped at the opportunity to gain this valuable knowledge and said yes to their generous proposition. So for one year I listened and watched very closely, until I learned from A to Z how these financial wizards made thousands of dollars every single day. I'll always be most grateful to these men for teaching me their fast and easy money making secrets. It didn't even matter that I was practically penniless when I first put these methods into action.

SUDDENLY IT STARTED MAKING MONEY FOR ME

At first it was unbelievable... I paid off all my bills and my wealth continued to multiply. Huge sums of cash poured in so fast that I was forced to employ a full time bookkeeper and retain a corporation attorney, accountant and a tax expert to help manage my prosperous financial affairs.

We had investments, property, stocks, money in the bank and can afford most anything we want. My family and I enjoyed our wealth and success. We were very proud of our accomplishments and it was our secret of making the right easy moves that made it all happen.

THIS IS YOUR CHANCE DON'T BLOW IT

It's a better chance than I had. If you're really serious I'm willing to share my secret. Surely I can afford to give it to you free of charge, but I won't, why should I give you something for nothing? Instead I'm going to ask you to send me ten dollars for sharing my secret. What's more, I want you to know that I intend to make a fair profit

from the information I mail you, why not? If I can show you how to make more money than you ever made in your life why should you care if I make a profit? Remember what I'm giving you for only ten dollars cost me 12 years to master. Even more important you get certified and documented proof beyond the slightest doubt that my method can make a fortune, this is why I can offer you the strongest legally binding guarantee possible!! A guarantee so incredible that you'll probably think it sounds too good to be true.

UNUSUAL \$1000 GUARANTEE

This is a legal and binding guarantee from me to you. The information I'll send you can actually put thousands of dollars in your pocket. But this is my pledge to you, after just 10 days if you don't agree my secret method is worth at least \$1000.00 in cash to you (one hundred times the ten dollars you pay) send it back and I'll rush a full refund, including your 84 postage. You take absolutely no-risk —not even the price of a stamp.

GET READY TO GET RICH

Every single day my method can bring you more cash. You'll never again need to borrow, budget or ask anyone for credit. You'll be proudly independent. You can enjoy those luxuries you've always dreamed about, but never could afford. Sound impossible? But it's not, you only need a serious belief in my proven method, very small capital and enough ambition to give it a try. Remember "nothing ventured nothing gained" and there's absolutely no way you can lose.

JOIN THOUSANDS WHO ENJOY THE RICH GOOD LIFE:

Ed K. says: "I never earned over one hundred dollars a week in my life until I

made 2 thousand dollars the first month using your money making method. I'm glad I took a chance. Sincerely, Ed K., N.Y. You can easily learn what I taught him and now his money worries are over, so why not take advantage of this rewarding opportunity. Any news of good fortune travels fast, already thousands of just average men and women have benefited from my concept, you will too. But I will not promise you'll make as much money as fast as I have, yet, it's possible you'll make a lot more even faster.

YOU CAN LIVE HIGH ON THE HOG AND DO LESS WORK...

I'll show you how to stop breaking your back to make ends meet and start using your head to get easy riches. If you're seriously fed up with being treated like a hard working stiff while others enjoy the rich good life, then don't pass up this opportunity—you risk absolutely nothing—not even the price of a stamp.

MAKE THE RIGHT MOVE NOW

RUSH ORDER COUPON

Ernie Tucker, Pres.
Unique Ideas, Inc. Dept. PEE-W
1674 Broadway
New York, N.Y. 10019

Yes count me in on your \$1000 guarantee offer. I enclose \$10. Rush your proven easy money method. I understand that it has been officially certified, notorized and documented. If I don't agree it can actually put \$1000 or more in my pocket within 10 days I can return it for a full refund, including my 10¢ postage. There is no risk on my part.

Name.....
Address.....
City.....
State..... Zip.....

CIRCLE NO. 12 ON READER SERVICE CARD

BY MITCHELL WAITE

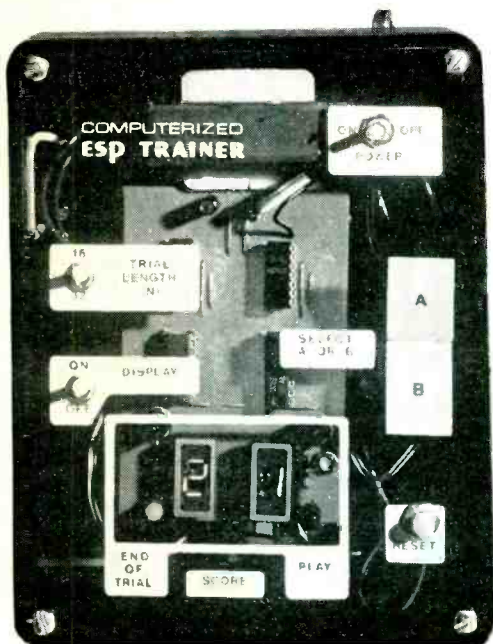

Check your Psi Quotient with this ESP TESTER!

YOU CAN RUN SOPHISTICATED TESTS OR USE THE MACHINE AS A SURE-FIRE PARTY GAME

DID you know that electronics technology is being used to confirm extra-sensory-perception (ESP), among other psychic phenomena? Using digital logic, radioactive decays, and computer programs, scientists are showing that:

- A possible link exists between business success and ESP.
- Mind may influence matter even at microscopic levels.
- ESP communications may be just around the corner.

The ESP tester described here is actually a random-number generator and a testing circuit that records and displays your hits and misses. It uses inexpensive TTL logic and a simple transistor as a random-noise source. Thus, your experiments with this device guarantee that the target selection is totally beyond any known physical effect and that recording error is eliminated. With it, you can actually conduct an unbiased investigation of ESP, as well as play some entertaining games.

In Parapsychology it has become standard

to use a "two-tailed" distribution. This, in effect, doubles all probabilities. The reason it's called two-tailed is that both halves of the probability distribution are used rather

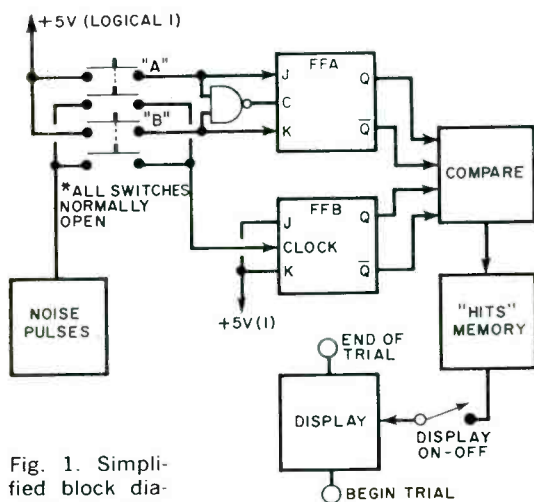

Fig. 1. Simplified block diagram of unit.

choose odds of 20 to 1 as good indicators of the truth of a statement of theory. If such odds are repeated a large number of times, we have the beginnings of a theory. Parapsychologists use odds of 100 to 1 as evidence of Psi. Probabilities between a 100:1 and 20:1 are considered suggestive but inconclusive. Anything over 100:1 is considered significant enough to repeat the experiment. Whether to multiply your resulting probabilities by two or use 20:1 or 100:1 depends on how you plan to use the results.

There is one additional technique becoming popular in analyzing for Psi. It's called the variance differential effect (VDE). Mainly, the VDE gives us a way of measuring the resulting fluctuations in scores as they vary about the mean. For instance, look at these results from a test using the ESP machine with "n" on 16: 0, 16, 0, 16 and 8, 8, 8, 8. In the first case, the scores vary greatly about the mean and have a large VDE. The normal analysis, however, would tend to cover up the large variations and

Fig. 2. Schematic and parts list. See Fig. 4 for diagram of power supply.

PARTS LIST

R1, R2—1000 ohm, 1/4-watt resistor
 R3, R4, R21, R22—2000 ohm, 1/4-watt resistor
 R5—3900 ohm, 1/4-watt resistor
 R6, R7—68 ohm, 1/4-watt resistor 10%
 R8, R24, R25—220 ohm, 1/4-watt resistor 10%

R9, R11, R12, R17, R20—100,000 ohm, 1/4-watt resistor
 R10—1 megohm, 1/4-watt resistor
 R13, R16, R19—10,000 ohm, 1/4-watt resistor
 R14, R15, R18—27,000 ohm, 1/4-watt resistor
 C1, C2—1.0 μ F, 10-volt electrolytic capacitor
 C3, C4, C5, C7, C8, C16—10 μ F, 10-volt electrolytic capacitor
 C6, C9, C10, C11, C17—0.05 μ F disc or Mylar capacitor

D7—1N4001 silicon diode (or equiv.)
 Q1—2N2712 transistor (see text)
 Q3, Q4, Q5—2N697 transistor (or equiv.)
 IC1, IC2, IC3—Monostable multivibrator (SN74121)

IC4—Dual JK flip-flop (SN7473)
 IC5, IC8—Quad two-input "and" gate (SN7400)

IC6, IC7—4-bit binary counter (SN7493)
 IC9, IC10—BCD counter (SN7490)

IC11, IC12—BCD-to-7-segment decoder/driver (SN7417)

IC13, IC14, IC15—711C op-amp (mini DIP or TO-5 package)

DIG1, DIG2—Minitron incandescent display (Series 90 in 16-pin DIP package)

Available from Solid State Systems, Inc., P.O. Box 617, Columbia, Missouri 65201

LED1—Light-emitting diode (red or yellow diffused lens)

LED2—Light-emitting diode (green diffused lens)

S1, S2—Spdt switch (Archer 275-016 or equiv.)

S3, S5—Spdt miniature toggle switch

S4—Spst normally open pushbutton switch

Misc.: Phenolic enclosure (Calcraft K4-668); fuse holder; line cord; 1 1/2 x 6-32 screw and four nuts; 1 1/2 x 6-32 spacer; wire; solder; Molex connectors (optional); plastic tabs for switches.

Note: The following are available from Circuit Craft Corporation, Box 38, San Rafael, Cal. 94901: etched and drilled PC boards (EEH-1) at \$15.00 (1 lb); drilled and silk-screened panel and case (FEH-2) at \$7.50 (2 lbs); complete kit of parts (EEH-3) at \$79.50 (4 lbs). Add sufficient amount to cover shipping according to weights given. California residents please add 6% sales tax.

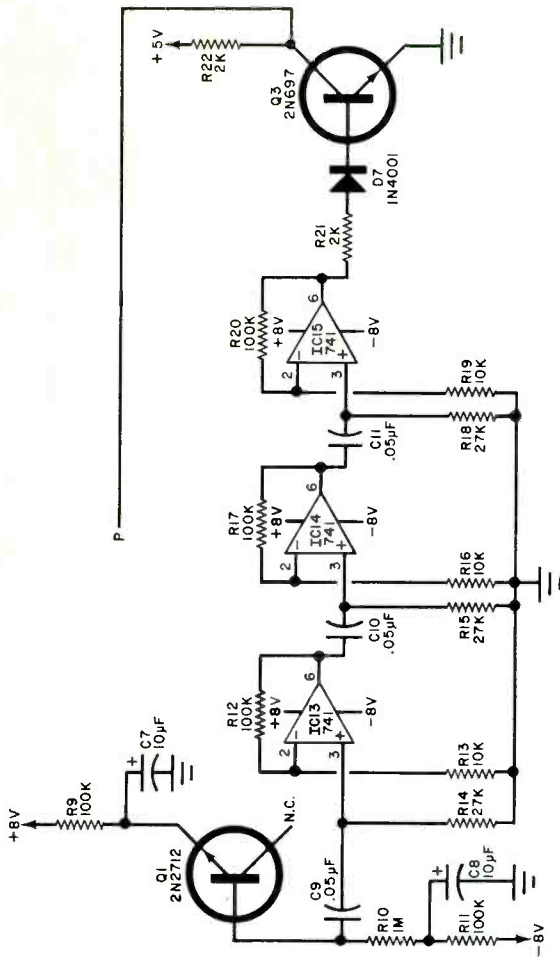

give an average of 8, which is at chance. The second set has a very low VDE and is obviously not the kind of patterns indicative of random events.

Theory of Operation. Referring to the simplified block diagram of Fig. 1, a reverse-biased transistor junction provides the source of noise or randomly distributed frequencies. Such noise pulses are the result of unpredictable quantum actions inside the junction and are considered one of Nature's most elementary random processes. The randomness gives us a nondeterministic number generator since there is no way we can predict when the next noise pulse will occur.

When either the "A" or "B" switch is depressed, two things happen simultaneously. A digital logic "1" is latched (stored) in the Q or \bar{Q} of the flip-flop labeled A (depending on which switch is pressed) and the noise pulses toggle flip-flop B a random number of times and leave it resting with a "1" in either its Q or \bar{Q} . After all this action has settled down (50 milliseconds in our device) the contents of the two flip-flops are compared and if they are the same, you are given a "1" and the "score" counter increments by one (so does the display, if it's turned on). If the contents of the flip-flops are different, you guessed wrong, and are given nothing (the counter stays the same).

The idea, of course, is to make the number on the display as large or as small as you can. An internal counter counts the number of switch depressions and after a preset number (16, 32, 64, 128) the "A" and "B" switches lock up and an "End of Trial" LED comes on. The number on the display can then be assigned a probability value.

With circuitry doing everything but guessing, there's no chance that the results are due to bias or skill on a strictly physical level. With some simple statistics, the results can be used to show objectively whether or not ESP—PK or precognition—is occurring.

Circuit Description. In the schematic of Fig. 2, along with the complete block diagram of Fig. 3, we can divide the circuit into seven parts: (1) the "A" and "B" switch inputs; (2) the random-number generator; (3) the memory which counts every switch depression; (4) the memory which counts the hits; (5) the display; (6) the automatic reset flip-flop and LED's; and (7) the power supply.

Depressing S1, the "A" switch, causes monostable multivibrator IC2 to go high (logical "1") for 25 milliseconds. This "on" time is controlled by R3 and C3. Likewise, pressing S2, the "B" switch, causes mono

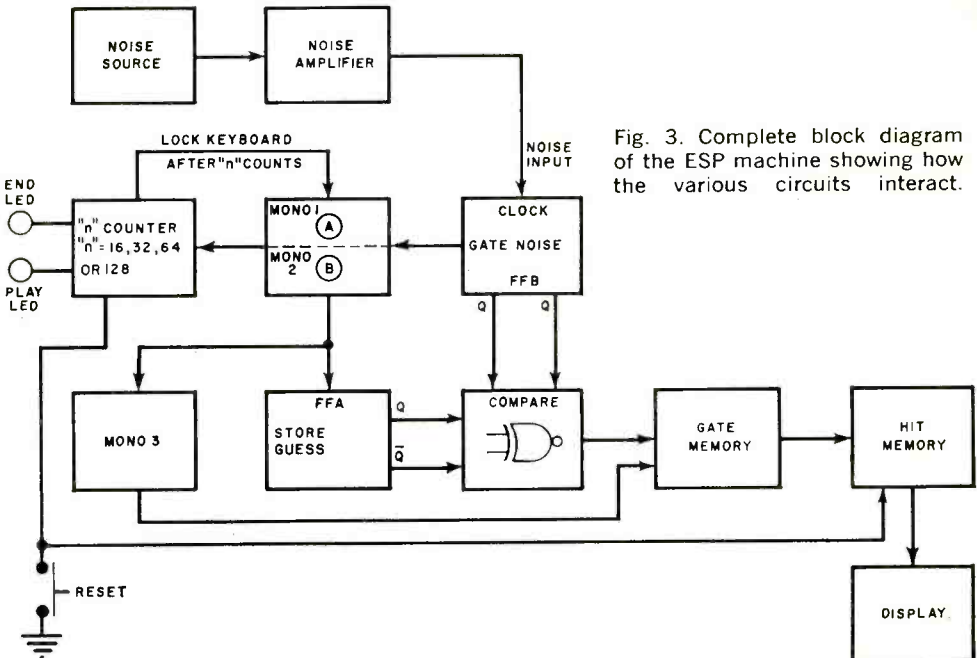
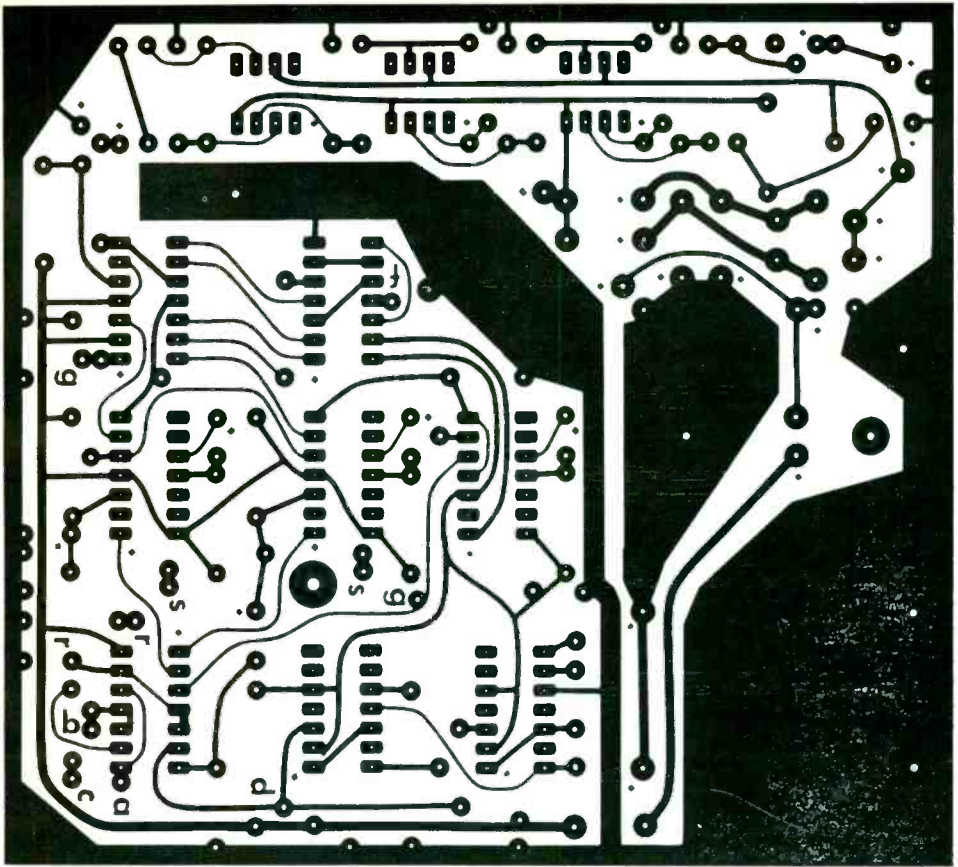
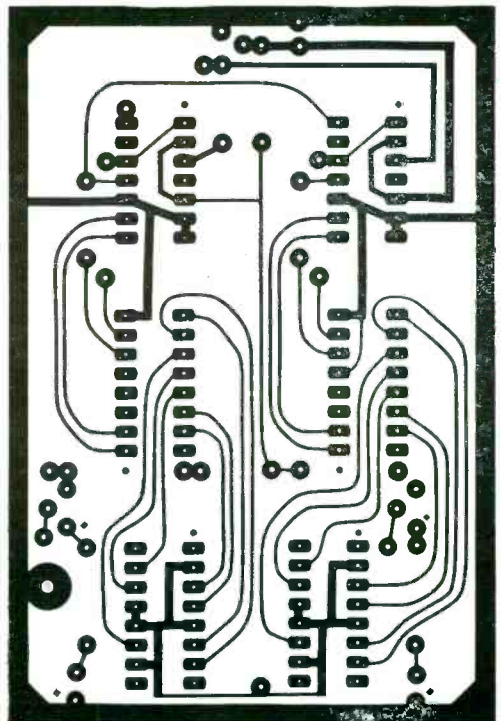

Fig. 3. Complete block diagram of the ESP machine showing how the various circuits interact.



Printed-circuit board with the logic, "n" counting, and linear amplifiers circuits, plus power supply. See p. 16 for parts layout.

Board for the two-digit display, the "Hits" memory, and instruction LED's.



IC1 to go high for 25 milliseconds. If *S1* were pressed, causing *IC2* to go high, then a high is stored in the *Q* of flip-flop *IC4B*. If *S2* were pressed, the high is stored in the \bar{Q} of flip-flop *IC4B*. A signal to either input of *IC8A* does three things: it causes flip-flop *IC4B* to latch, it causes flip-flop *IC4A* to unlatch, and it causes *IC3*, the third monostable, to trigger. During the 25 milliseconds that flip-flop *IC4A* is unlocked, noise pulses will cause it to toggle a random number of times, leaving its *Q* or \bar{Q} with a logical "1" in it. Because the clock input receives a burst of random noise, there is no way the system will favor a particular state.

CONDUCTING AN ESP EXPERIMENT

The most fun in ESP is finding out who has it. With this ESP machine you can discover which people have the ability to influence random events and, by relating how they score to the experimental studies, you can draw some interesting conclusions.

Obviously, the greater the number of tests performed, the more valid the results. The catch is that long tests tend to cancel out Psi in general. Therefore, one should design experiments that keep up the subject's interest. The most interesting results occur, it seems, during psychologically heightened but pleasing conditions. Parties make an especially good setting for whipping out the machine.

A good run, one that will show variance differential effects, might have "n" set to 16 and consist of a total of 28 runs of 16 trials. Total trials will then be 28×16 or 448. Breaking the 28 runs into quarters of seven runs each, with a break in between, helps keep interest high. You can average seven runs in each quarter or wait until all runs are completed.

Tell participants that the device is an electric coin flipper and the idea is to guess how the "coin" will land by pressing either an "A" or a "B" switch. Show them that

repeated random pressings of either switch produce a "score" on the display. The score, barring any Psi effects, should be close to $n/2$ or an average of 8, most of the time. Tell them the goal is to produce as high or as low a number as possible on the display. Ask the subjects to take their time and feel out each guess.

Inform the participants that the display can be shut off if it interferes with the test. Each time the "End of Trial" LED comes on, record the number on the display. Repeat this seven times. Then add all the scores you've recorded and divide by seven. This will be your first quarter average. Repeat the process three more times. Examine quarter-to-quarter scores. Does the score start high, drop down, then rise again toward the end? Compute the CR_{diff} or differential critical ratio by subtracting the lowest average score from the highest average score. Is the VDE high or low? Save the results from each person's test. After a large number of tests you can pool your data and take a look at the gross Psi effects.

Some people will want to press a single switch all time time, "willing" the number on the display to change. This is a perfectly acceptable test for PK.

Other Uses for the ESP Machine

One can find all kinds of ways to use the ESP machine. For example, it makes an excellent home entertainment game of chance if the display switch is used. By shutting off the display, players can compete at guessing the score. Here's just a partial list of games; use your imagination for others:

1. High score wins. Display on or off. Stop after $\frac{1}{2}n$ is reached, that is, after half way.

This is an option, however, and rules of your own may be substituted.

2. Low score wins. Like above, but going for the low score.

3. Closest score to $\frac{1}{2}n$ wins. In other words, the person coming closest to chance prediction wins.

4. Largest differential score wins. Play two runs. Subtract scores. Largest difference wins.

The outputs of *IC4A* and *IC4B*, the two flip-flops, are monitored by *IC5*, an exclusive-NOR configuration of NAND gates. According to the truth table for exclusive-NOR, only coincidences between outputs will give an output, that is, if both Q's are a "1" we get an output or if both are "0" we still get an output.

Therefore, after 25 milliseconds the flip-flop with the noise has changed states about 1000 times, the output of the exclusive-NOR has gone high every time a coincidence occurred and is now resting with its output high or low. Now we need some way to convey to the "Hits" memory whether we have a hit or a miss. *IC3* is a mono used to lock up the display while the random numbers are being generated. It does this by sending a low to gate *IC5D* for 50 milliseconds when it is triggered by the "A" or "B"

switches. Now, 25 milliseconds after the exclusive-NOR has made its comparison, *IC3* goes back to its normally high state. If the output of the exclusive-NOR gate is high, then *IC5D* will go low when this mono returns high. This is a "Hit" condition and causes the memory counter, *IC9* and *IC10*, to go up by one count. If, however, when *IC3* goes back to being high, the output of *IC5C* is low, then the output of *IC5D* will either go high, or stay high if it was already. Both conditions signify a "Miss" and don't affect the counter. All these operations take place within 50 milliseconds, which is about two times faster than you can hit the switch. No provision has been made for pressing both switches together and it isn't recommended. There is no real reason to press the switches at high speed anyway.

We need some way to show when a cer-

tain number of switch depressions have been made. This will constitute "n." We use IC6 and IC7 to do this. They are 4-bit binary counters which can count from 16 to 256. Our display, however, can only count to 99 so any "n" which might give a score larger than this is out. Further, a count under 16 doesn't give sufficient probabilities. Thus, we are left with four trial lengths: 16, 32, 64, and 128. Sixteen has been found to be a very comfortable setting since it is short enough to eliminate boredom, but long enough to give probabilities that exceed 65,536:1. Switch S3 allows us to choose two of the four "n"s.

When the output of counter IC7 falls low, the desired count has been reached and a low trigger pulse is sent to reset flip-flop IC8. This causes LED1 to come on, signaling the end of that part of the test. It also causes monostables IC1 and IC2 to lock up. It does this by feeding a low to the Schmitt inputs of these IC's. With these inputs low, pressing S1 or S2 will have no effect and the number displayed will be the total number of "Hits."

Pressing S4, the "Reset" button, puts a low at the input to reset flip-flop IC8C, causing the flip-flop to change states. Now

the "End" LED goes out and the "Play" LED comes on. At the same time all the counters are reset to zero and you are ready for another run. If at any time within a run you want to start over, simply hit the "Reset" button.

The noise source consists of a reverse-biased transistor emitter-base junction. The transistor used in the prototype was a 2N2712 which has a reputation for breaking down easily, however, not all 2N2712's will do this. Out of five tried, four worked. The ultimate frequency of the noise pulses will depend on the bandpass of the amplifiers through which they pass. In this circuit, the overall frequency is about 300 to 70,000 Hz. At 70,000 Hz, and with a 25-millisecond sample period, the flip-flop will be toggled about 1000 times. This is fast enough to guarantee a high degree of randomness. R10 sets the bias current of the Q1 noise transistor while R9 and C7, along with R11 and C8, block any 120-Hz in the power supply from entering the noise source. IC13, IC14, and IC15 are then non-inverting op-amps, each with a gain of 10. Noise from the diode junction reaches about 6 volts peak-to-peak at the output of IC15. From here the noise signal is rectified to remove

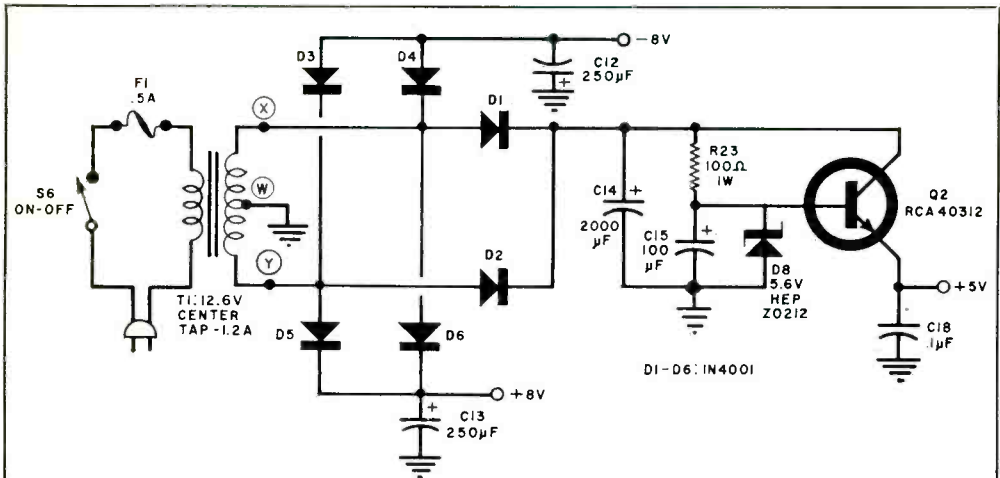

Fig. 4. Schematic of power supply. PC board construction is suggested.

PARTS LIST

R23—100 ohm, 1-watt resistor 10%
 C12, C13—250 µF, 10-volt electrolytic capacitor
 C14—2000 µF, 10-volt electrolytic capacitor (two 1000 µF units can be used)
 C15—100 µF, 10-volt electrolytic capacitor

C18—0.1 µF disc capacitor
 D1, D2, D3, D4, D5, D6—Silicon diode (1N4001 or equiv.)
 D8—5.6-volt zener diode (HEP Z0212)
 Q2—npn transistor (RCA40312 or equiv.)
 T1—12.6V, 1.2 A (c.t.) transformer
 F1—0.5 A fuse
 S6—Spst miniature toggle switch

negative components and fed to Q3 where it is converted to the 5-volt logic level.

The power supply consists of a series-pass regulated stage for the 5-volt logic and a non-regulated ± 8 volts for the op-amps. NOTE: The transformer in the supply may get hot unless adequate ventilation is provided.

Construction. Building this circuit is easier if you do it in sections. Circuit boards are almost a "must," since wiring could be complex. The circuit is split into two sections; the logic for comparison, for "n" counting, and the linear amplifiers are all on one board, along with the power supply. Another board holds the two-digit display and "Hits" memory, along with the instruction LED's.

Begin by building the power supply (Fig. 4). After all parts are in place you should test the supply with a 20-ohm load resistor. Ripple should be less than 10 millivolts peak-to-peak. Next build the ± 8 volt supplies, along with the noise amplifiers. The output of the noise amplifier should oscillate between 0 and 5 volts.

Next, install the logic circuitry and the twelve jumpers, being very careful of pin locations on the IC's. Use the parts layout guides shown below to get the various components in the right places.

Probabilities (odds against) for "n" = 16

ODDS

SCORE	NORMAL	BINOMIAL
	(high number runs)	(short number runs)
16	322,580:1	65,536:1
15	4255:1	4166:1
14	740:1	551:1
13	161:1	117:1
12	44:1	36:1
11	15:1	15:1
10	6.3:1	8.5:1
9	3.2:1	5.8:1
8	1:1	5.24:1
7	3.2:1	5.8:1
6	6.3:1	8.5:1
5	15:1	15:1
4	44:1	36:1
3	161:1	117:1
2	740:1	551:1
1	4255:1	4166:1
0	322,580:1	65,536:1

After finishing the logic board, move to the display board and install all of its components, followed by jumpers and then LED's. Test to see that the display will reset by grounding the reset input after feeding it some counts. It should return the display to zero.

Finally, hook up all switches and you are ready to go. A professional-looking panel can be made of smoked plexiglass. ♦

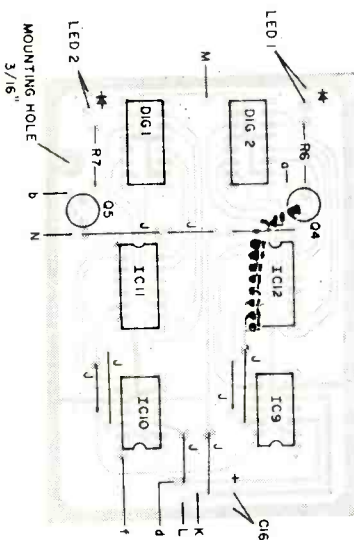

Parts location guides for (above) display board and (right) balance of ESP tester.

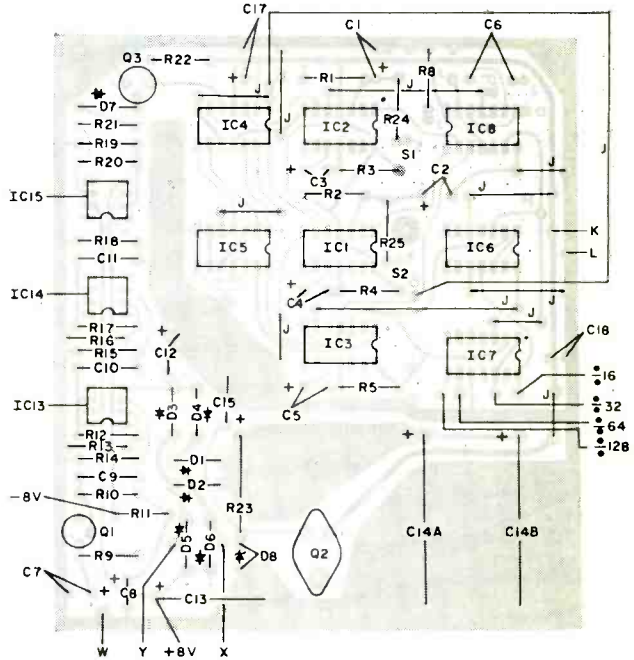

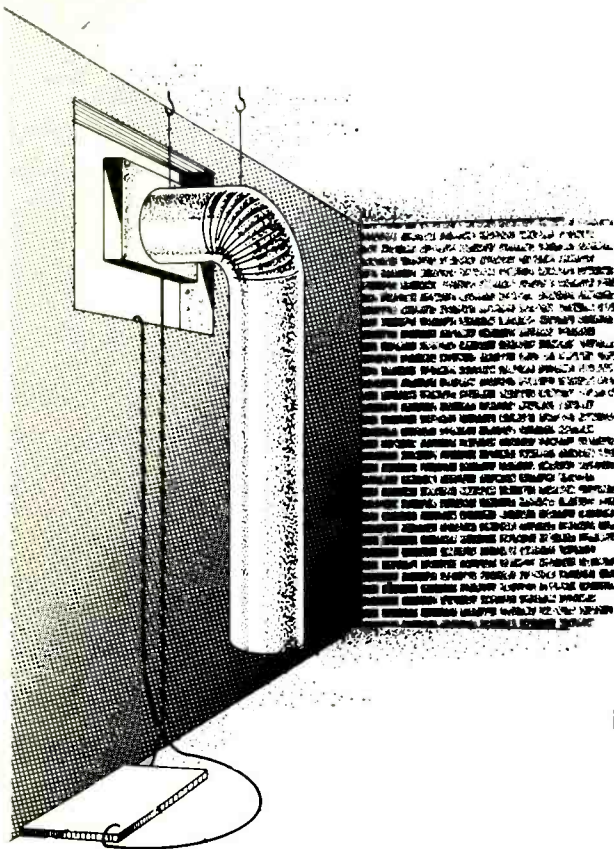

DIFFERENTIAL-TEMPERATURE BASEMENT VENTILATOR

KEEPS OUT MILDEW AND MOLD

BY JIM ASHE

FORTUNATE indeed is the home owner who can say that his cellar stays completely dry year round. When the weather is hot and humid outside and relatively cool and humid in the basement, moisture, mold, and mildew usually start to collect. The situation can be greatly improved by equalizing the temperature differences.

The project described here consists of a ventilating system to draw the cool, damp air from the floor of the basement and replace it with warmer air from outside. The system includes an electronic differential circuit which senses the temperature difference between inside and outside and turns on the ventilating fan when necessary.

A typical small axial fan, mounted in a 6" diameter stove pipe can move about 100 cubic feet of air per minute. Assuming a 50' x 20' x 7' basement, it will take the fan about 70 minutes to change the air. Of course, using a larger fan or having a smaller basement will change the time. For maximum benefit, the ventilator should be run every day.

How It Works. The circuit used to detect the temperature difference is shown in Fig. 1. Essentially it consists of an operational amplifier (IC1) whose output state is determined by the voltage drop across a pair of germanium temperature-sensing diodes, D1 and D4. This voltage drop is dependent not only on the current flowing through the diodes but also on the ambient temperatures surrounding them. The integrated circuit is connected as a differential amplifier whose output is coupled to a Schmitt trigger consisting of Q1 and Q2. The trigger circuit converts the relatively slow action of the output of the op amp (due to the slowly changing voltage across the diodes) to a fast-acting switch. The trigger, although it is a form of multivibrator, does not change the frequency of operation. Since such a circuit is regenerative, its action is fast; and slow input signals become sharp, decisive outputs.

Although it is possible to connect the motor control relay to the collector circuit of the Schmitt trigger (Q2), some added

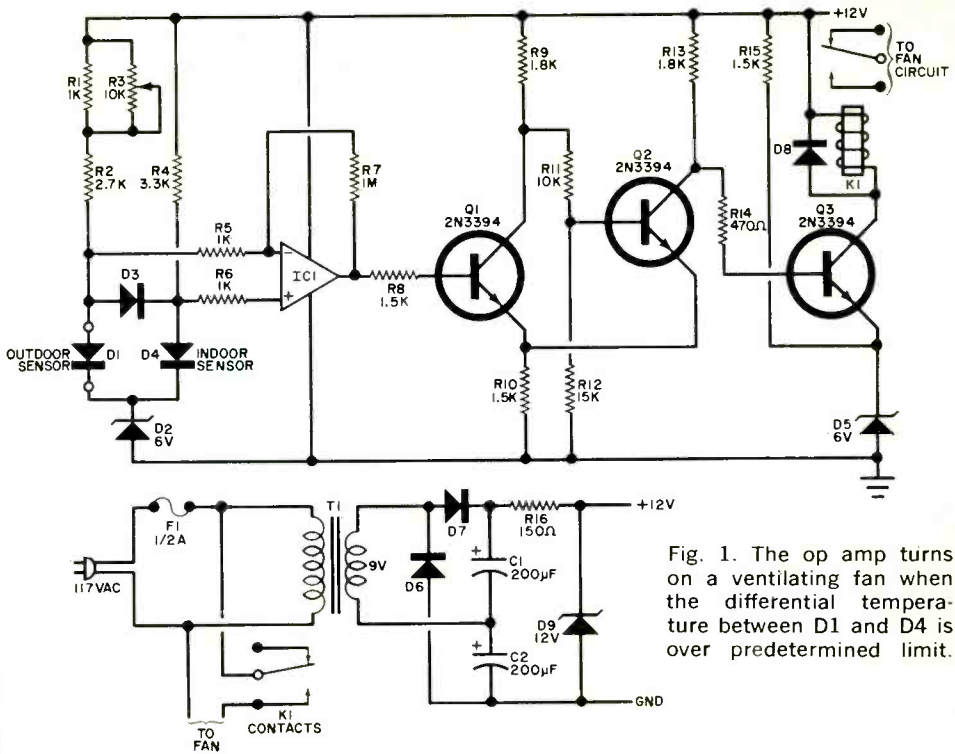

Fig. 1. The op amp turns on a ventilating fan when the differential temperature between D1 and D4 is over predetermined limit.

PARTS LIST

C1, C2—200- μ F, 15-volt electrolytic capacitor
 D1, D4, D8—Germanium signal diodes (HEP 134, D1 and D4 matched. See text.)
 D2, D5—11EPZ0214 6-volt, 400-mW zener diode
 D3, D6, D7—Silicon diode (HEP 154 or equiv.)
 D9—11EP105 12-volt, 1-W zener diode
 F1— $\frac{1}{2}$ A fuse and holder
 IC1—Operational amplifier (741 or similar)
 K1—500-ohm, low-current dc relay
 Q1, Q3—2N3394 transistor
 R1, R5, R6—1000-ohm, $\frac{1}{2}$ -watt resistor
 R2—2700-ohm, $\frac{1}{2}$ -watt resistor

R3—10,000-ohm potentiometer
 R4—3300-ohm, $\frac{1}{2}$ -watt resistor
 R7—1-megohm, $\frac{1}{2}$ -watt resistor
 R8, R10, R15—1500-ohm, $\frac{1}{2}$ -watt resistor
 R9, R13—1800-ohm, $\frac{1}{2}$ -watt resistor
 R11—10,000-ohm, $\frac{1}{2}$ -watt resistor
 R12—15,000-ohm, $\frac{1}{2}$ -watt resistor
 R14—470-ohm, $\frac{1}{2}$ -watt resistor
 R16—150-ohm, 1-watt resistor
 T1—Filament transformer; secondary: 9 V at 100 mA
 Misc.—Length of two-conductor cable, chassis, stovepipe and elbow, 117-volt axial fan, socket for IC1 (optional), mounting hardware.

working margin is included by using the trigger to drive a biased power stage, Q3, which has the relay in its collector circuit. The emitter of Q3 is biased by R15 and zener diode D5, so that Q3 is either on or off. When the positive-going signal from Q2 occurs on the base of Q3, it turns on very fast, energizing the relay.

The amplifier compares voltages across the two diodes, D1 and D4. Diode D3 acts as a safety diode if the circuit happens to have power applied when D1 is not in the circuit. This is necessary to protect the op amp. Feedback resistor R7, in conjunction with the 1000-ohm input resistor produces a

stage gain of 1000 in the op amp. To reduce temperature sensitivity, R7 can be replaced by a smaller resistor to reduce circuit gain.

Zener diode D2 clamps the input circuit at 6 volts, since the op amp cannot accept signals near ground or close to 12 volts. Most operational amplifiers do not have this problem as they are operated by either a positive or a negative supply.

Diodes D1 and D4 should be as alike as possible and should be checked by measuring their forward voltage drop. This is done by connecting a resistor in series with the diode and power source and measuring the diode drop very carefully. Final adjustment

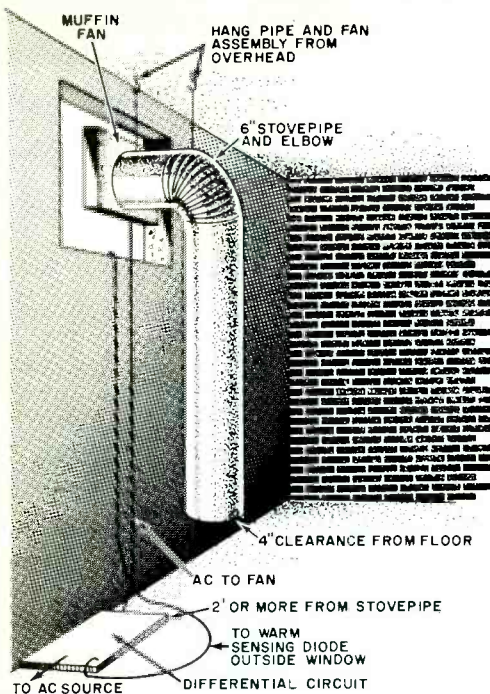
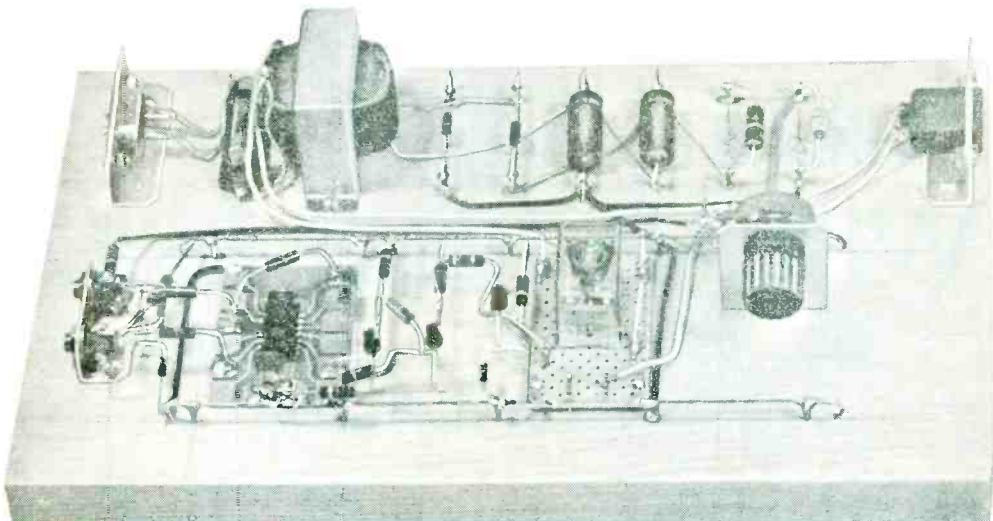

Fig. 2. Diagram shows how to install the fan (in stovepipe) in a basement window, to draw out cool, damp air.

of the bridge will be made by $R3$. Reducing the value of $R3$ raises the $D1$ current simulating a falling temperature outdoors or a rising temperature indoors.

The electronic circuit for differential temperature sensing can be easily assembled on a breadboard as shown here. It should be positioned two feet from pipe.



Construction. The circuit can be constructed on perf board or a printed circuit board. There is nothing particularly critical about the circuit. Diode $D4$ is mounted on the circuit board in such a way that air can circulate around it. Diode $D1$ is mounted outside the basement window and connected by a length of ordinary two-conductor cable. Do not place $D1$ where it will get direct sunlight, since the excessive heating will produce false results.

The mechanical arrangement is shown in Fig. 2. A suitable length of 6" stovepipe with an elbow is the main element. The axial fan is mounted to the end of the elbow as shown and the entire assembly is suspended so that the fan is in the window (remember it exhausts the basement air) and the bottom of the stovepipe is about 4" from the floor. Keep the electronic circuits, especially $D4$, at least two feet away from the bottom of the stovepipe so that the moving air will not cool the diode and produce a false indication in the differential circuit.

Calibration. With $D1$ and $D4$ close to each other, allow them to stabilize for an hour or so. Then set $R3$ a little bit beyond where the relay opens. The two diodes are now temperature matched. If a large fan is required, and the current demand is more than the $K1$ contacts can tolerate, use $K1$ to drive a power relay or a simple SCR or triac controller. ♦

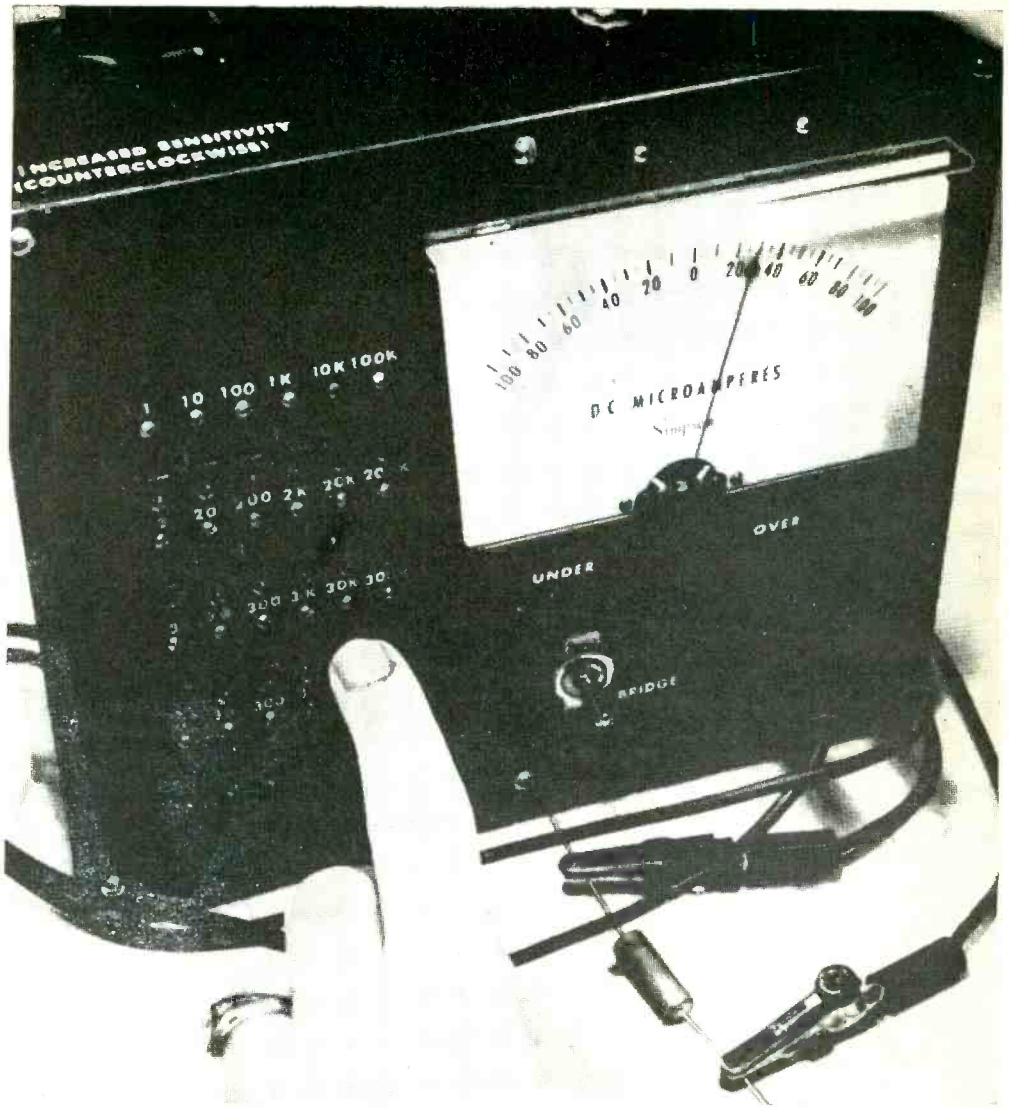

Build a WHEATSTONE BRIDGE

*999,999 Resistance Values
to Measure or Substitute*

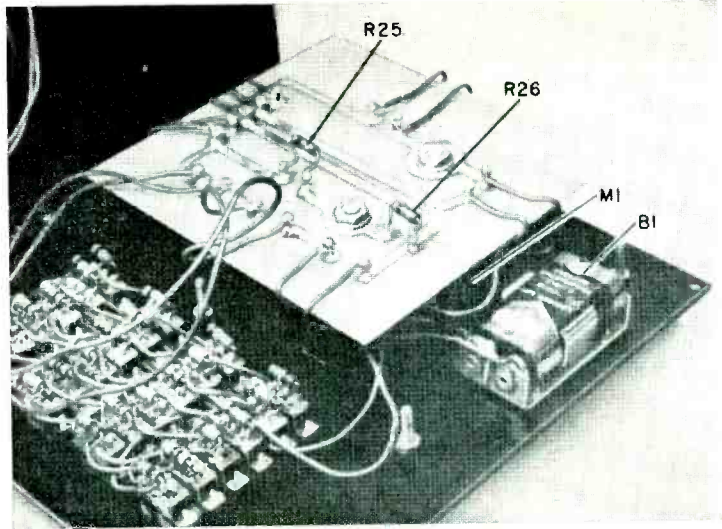

A PC board, mounted directly on meter terminals, is used to hold two bridge circuit resistors as well as provide connection points for the circuit wiring.

Here is a versatile project that will serve the experimenter or technician in two ways: It can be used as a test instrument to measure any resistance value from 1 ohm to 1 megohm; and it can provide substitute resistors over the same ohmic range to be plugged into any circuit.

MURPHY's "Law of Resistors" states that you never have the value of resistor needed to test a particular circuit and that, when measuring a resistance value (using a VOM), the needle invariably goes to the crowded, difficult-to-read, end of the scale.

If you have these problems, you will want to build the combination Wheatstone bridge/resistance substitution box described here. At the flip of a switch, you can get resistance substitution values from 1 to 999,999

quite a few parts. As the schematic in Fig. 1 shows, this bridge/resistance box has only four resistors and four spdt switches in each decade. Not only does this represent a monetary saving, it also means that construction is simplified.

Note that the resistors in each decade are in a 1—2—3—3 arrangement. Thus in the first decade, you can obtain any value from 0 through nine by switching in the required values and shorting the others out. The same is true of all the other decades. Since the decades are in series, ohmic values from 0 to 999,999 are obtainable.

The Wheatstone bridge, whose simplified schematic is shown in Fig. 2A, is an electronic balance circuit. If R_1 , R_2 and R_3 are known, then R_x must have a resistance such that there is no voltage difference between points A and B in order to get a null indica-

SUBSTITUTION BOX

tion on the meter. When R_x is either higher or lower than the required balancing value, the meter will deflect to one side or the other by an amount proportional to the difference.

Conventional resistance substitution boxes have nine resistors and a 10-position switch for each decade. For six decades, a total of 54 resistors and six switches is required—

tion on the meter. When R_x is either higher or lower than the required balancing value, the meter will deflect to one side or the other by an amount proportional to the difference. If R_2 and R_3 are made equal and R_1 is adjustable, the value of an unknown resistance at R_x can be determined by adjusting R_1

until the meter reads zero and reading the resistance of R_1 .

As shown in Fig. 2B, potentiometer R_{27} controls the voltage applied to the bridge and provides a means of increasing or decreasing the sensitivity of the meter. The direction of meter movement is determined by the respective polarities of the meter and the battery. When the instrument is com-

plete, attach a known resistance to terminals $J1$ and $J2$ and determine the direction of deflection caused by too much or too little resistance. It is customary to make the left side of zero "too little" (or "under") and the right side "too much" (or "over"). Mark the meter to indicate which side is which. The scale itself does not actually have to be marked except for an indication at zero.

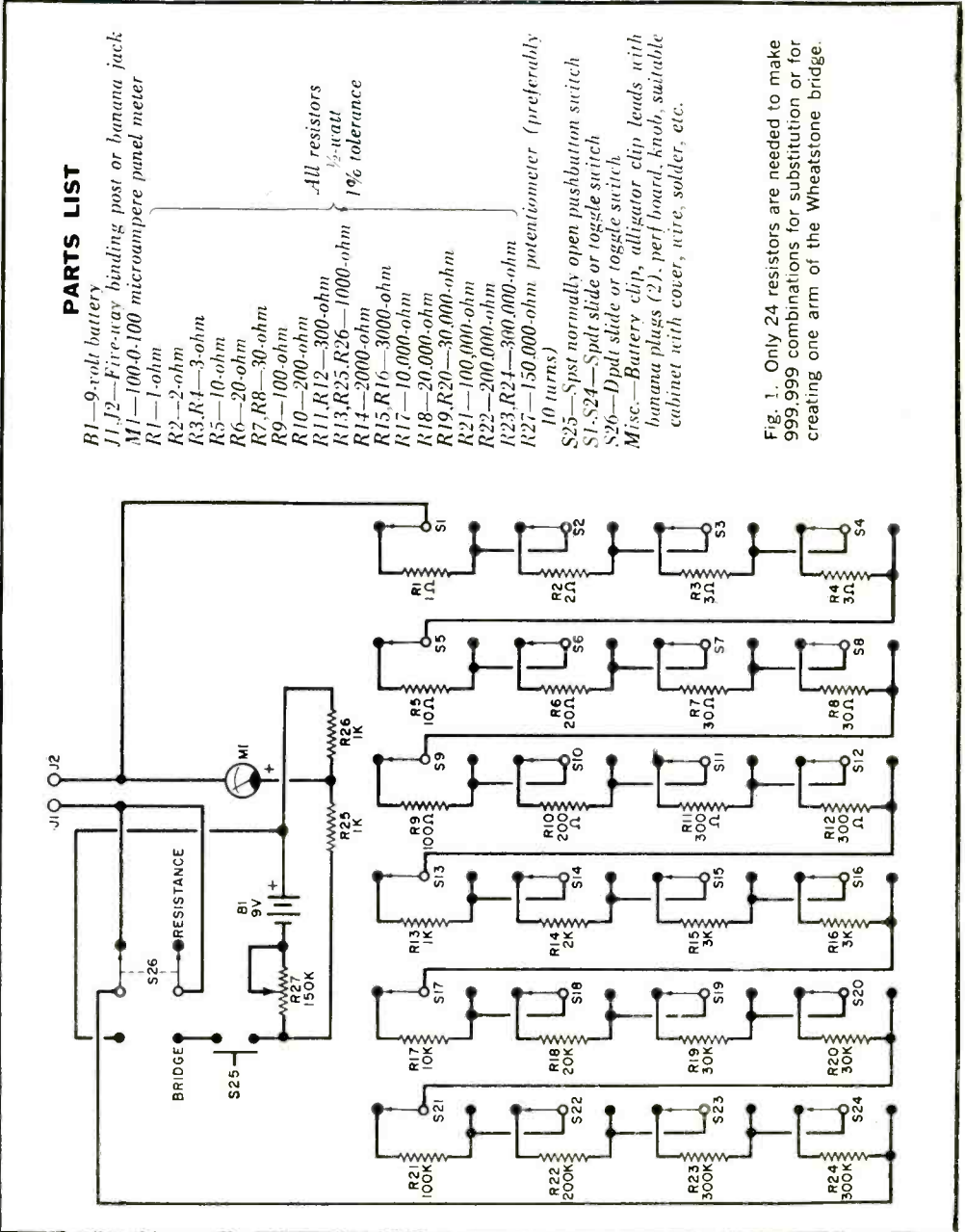

Fig. 1. Only 24 resistors are needed to make 999,999 combinations for substitution or for creating one arm of the Wheatstone bridge.



Any size zero-center microammeter may be used and the meter scale may be left "as is," or marked as "over" and "under" on the right and left sides. The meter scale divisions are not used.

Construction. The prototype was assembled in a large plastic case as shown in the photos. With the 24 switches mounted on the front panel, the precision resistors are connected directly to the switch terminals. In the prototype, the sensitivity control R_{27} and the bridge power switch S_{25} were mounted on the top of the cabinet with all other controls on the front. The battery is clip-mounted inside the chassis and the two

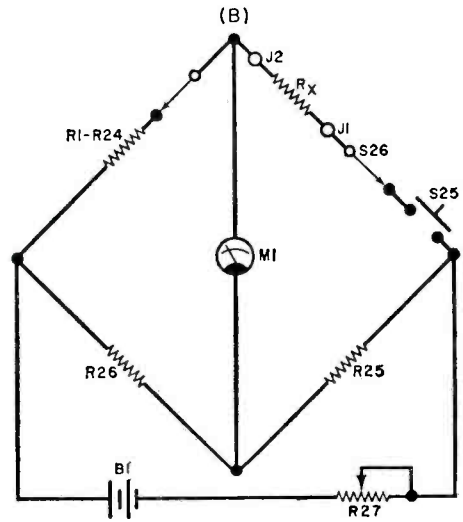
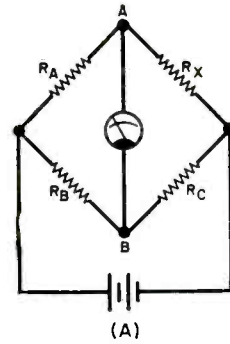
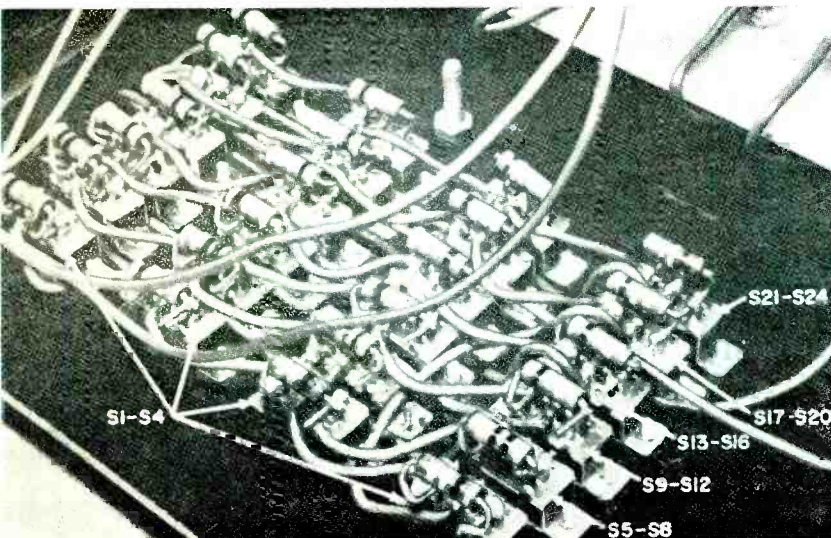

Fig. 2. The classical Wheatstone bridge is illustrated at A, while B shows how it is created in the bridge-substitution box project.



The bulk of the work is in cutting the holes to mount the 24 switches in the selector circuit. Be careful when drilling plastic as it shatters very easily. If there is any doubt, use a metal cover for the plastic container.

COMPUTER BOARD GRAB BAG

8 to 10 lbs. of exotic computer boards, containing every conceivable type of component. Transistors, diodes, integrated circuits, linear and digital, relays, zeners, precision resistors & capacitors. Resistors heat sinks and much more. Satisfaction guaranteed.
 STOCK NO. X9801 \$5.00 per set 3/13.00

HIGH POWER TRANSFORMERS

Hard to find high power transformer. 64 volts @ 6.0 amps. ct., 18 volts @ 8.0 amps. ct., 32 volts, @ 6.0 amp. & 400 volts @ .150 A. ct. Great for all those 250 watt power amplifiers.
 STOCK NO. X9905 11.95 ea. 2/22.00 5/50.

3 1/2" LIQUID CRYSTAL WRIST WATCH DISPLAY

The AEO129 Liquid Crystal Display specified in Jan. '74 POPULAR ELECTRONICS article! Build This Electronic Digital Wristwatch.

We supply reprint of article, and data sheets.
 STOCK NO. B 5192 With Socket \$19.75

MINIMUM ORDER \$5.00. Include sufficient postage; excess refunded. Send for latest 56 page catalog with exciting values.

DELTA ELECTRONICS CO.
 BOX 1, LYNN, MASSACHUSETTS 01903

CIRCLE NO. 4 ON READER SERVICE CARD

BE CHOOSEY. YOU CAN AFFORD TO WITH EICO

The more you know about electronics, the more you'll appreciate EICO. We have a wide range of products for you to choose from, each designed to provide you with the most pleasure and quality performance for your money. If you prefer, you can "Build-it-Yourself" and save up to 50% with our famous electronic kits.

For latest EICO Catalog on Test Instruments, Automotive and Hobby Electronics, Burglar-Fire Alarm Systems and name of nearest EICO distributor, check reader service card or send 50¢ for fast first class mail service.



Over 3 million Eico instruments in use since 1945.

EICO

283 Marit Street, Brooklyn, N.Y.

CIRCLE NO. 6 ON READER SERVICE CARD

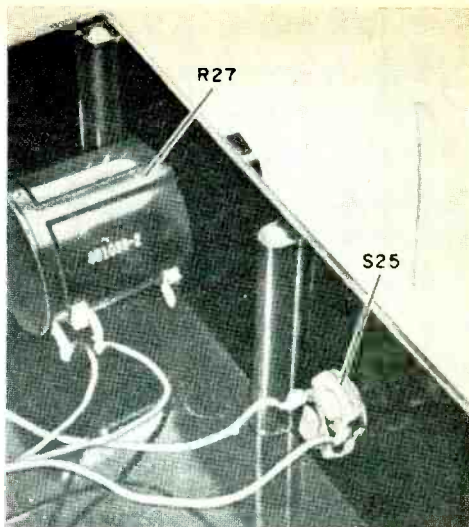

Author's prototype has a 10-turn potentiometer for close resolution but a conventional pot may be used instead.

resistors associated with the bridge ($R25$ and $R26$) are mounted on a small piece of perf board which is then attached to the meter terminals. The complete system is wired as shown in Fig. 1. When it is finished, use some form of rub-on letters to identify the various controls and the switches.

Operation. To use as a substitute resistor, place $S26$ in the RESISTANCE position and set the appropriate switches on the front of the instrument to total the desired value. The resistance is available across $J1$ and $J2$.

To use the Wheatstone bridge, place $S26$ in the BRIDGE position and set $R27$ for maximum resistance. Connect the unknown resistor to $J1$ and $J2$ with appropriate test leads. Depress pushbutton switch $S25$ and operate any of the resistor switches. Note the direction and amount of meter movement. If the meter reads "too little," increase the resistance; if "too much," decrease the resistance. Continue adjusting the known resistance until a null is obtained on the meter. As the needle is brought nearer zero, adjust potentiometer $R27$ to obtain greater sensitivity.

Once you get the hang of operating this bridge we venture to predict that it will be in use often and prove to be one of the handier items on your bench. Despite its seeming complexity, it is easy to build if you follow directions. ♦

BY DENNIS BERNIER

Director of Research & Development
Kester Solder Division, Litton Systems, Inc.

Solder & Soldering



*How to make reliable
soldered connections and insure
that your circuits will perform.*

IN electronic assemblies, solder is used to join metals more often than any other type of fastener. While much thought is usually given to choosing the correct electronic components and circuit layout, too often little attention is paid to choosing the proper soldering materials and learning the techniques for making reliable soldered connections. The failure of an expensive piece of electronic equipment can frequently be traced to a defective solder joint, a costly error made by an assembler with an inadequate understanding of soldering principles.

Soldering of electrical connections involves both scientific techniques and practical experience. The science of solder metallurgy and the chemistry of fluxes are carefully researched in solder manufacturers' laboratories, resulting in high-quality products for every soldering application. The user of soldering materials should become familiar with the requirements for making reliable soldered connections and develop the necessary skills in using the proper solder, flux, and soldering equipment.

The word "solder" is derived from the Latin "solidare," meaning "to make firm." Soft-soldering refers to joining metals at temperatures below 700° F, a low enough temperature to allow the use of simple tools and easy-to-learn techniques.

Solder Alloys. Although there are hundreds of solder alloys made from many different metals, the most common solders consist of a mixture of tin and lead. Fig. 1 indicates the melting point (solidus) and flowing point (liquidus) of several compositions of tin and lead.

When tin is added to lead, or lead to tin, the melting point of the original metal is lowered. The 63/37, tin/lead, composition is called the eutectic alloy since it melts and flows at the same temperature (361° F). The other tin/lead alloys melt with a "plastic range," where the solder is not completely melted and is in a pasty condition. The high-lead-content alloys (60-100%) are applicable in the plumbing industry because these alloys can be used to fill wide gaps. For electrical soldering, however, only the alloys near the eutectic composition

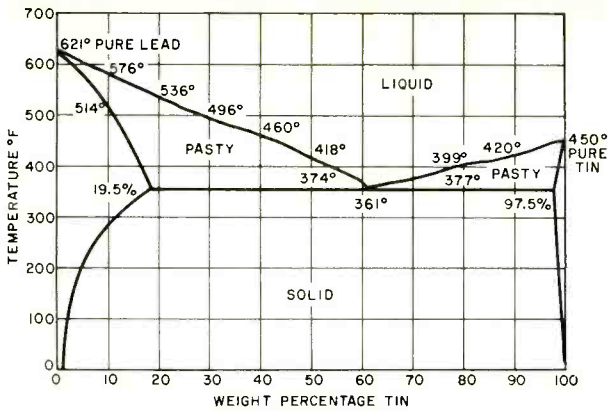

Fig. 1. Tin-lead diagram showing the melting and flowing points of several compositions of tin and lead solders.

(63/37) have the required low temperature and wetting properties.

Other special alloys are used; for instance, when soldering to silver, a solder with 2-5% silver can be used to prevent silver from dissolving into the solder. The choice of alloy is also dependent on the soldering temperature. It is recommended that soldering be done with the lowest melting solder alloy possible, to avoid heat damage to electronic components. Fig. 2 indicates the most common solder alloys and their melting temperatures.

Metal Solderability. Solderability is simply defined as a clean metallic surface. Removal of all dirt from surfaces to be soldered is essential. The soldering flux will remove only oxidation. Other dirt, such as wax, oil, grease, or epoxy on component leads, should be removed prior to fluxing and soldering.

Metals which do not oxidize, like gold and platinum, are the easiest to solder. But, because of their high cost and rapid dissolution in solder, these metals are best avoided for soldering. More common solderable metals used in making electronic components are copper, brass, nickel, cadmium, tin, and solder-plating—all of which form oxides or tarnish which a mild flux can remove.

Soldering requires that the melted solder dissolve small amounts of the solderable metal, such as copper, and form a new intermetallic compound between the solder and the solderable metal. This intermetallic layer is what holds the solder joints together.

Soldering Flux. When a metal surface, like copper, is exposed to air, the oxygen in the air will tarnish or oxidize the copper surface. This oxidation occurs even more rapidly when the surface is heated. So, the soldering flux must be able to remove a small amount of oxidation already on the surface and prevent oxidation during heating. *Only a clean surface is a solderable surface.* When the solder melts at elevated temperatures the heated metal surface must be clean for the solder to bond properly. The flux causes the solder to "wet" and spread out on the surface.

There are three types of flux: inorganic acid, organic, and rosin. For most electronic soldering applications only the rosin or resin (activated rosin) types can be used since the other types are acidic and too corrosive. Liquid fluxes are used for automated soldering or to assist in removing stubborn oxides when hand soldering. The most effective solder for hand soldering is one with a flux core. During rapid heating with the iron, the flux and solder are introduced to the joint simultaneously to complete the connection. The activated rosin flux is preferred because of its improved oxide-removal properties. For most applications, the rosin and resin fluxes which leave residues that are hard, non-sticky, non-conductive, and non-corrosive, need not be removed after soldering. If removal is desired, a flux-residue remover is recommended for the job.

Soldering Technique. Besides choosing the best soldering materials, care should

be taken to use a soldering iron which supplies the right amount of heat. The key word is *heat* and not *temperature*. The proper size soldering iron tip will have enough mass to rapidly heat the connection so that the flux-cored solder can be applied before excessive oxidation has built up on the metal surface. Too little heat will cause a cold solder joint, a case where the solder has solidified before dissolving the base metal to form the proper bond. Too much heat, on the other hand, may cause the solder to form too thick an intermetallic layer, causing a brittle joint.

A soldering-iron tip should be kept tinned at all times; that is, it should have a coating of molten solder. A copper tip will dissolve in the solder and eventually wear away, requiring re-shaping with a file and re-tinning. Copper tips are often iron-plated to prevent this erosion, but an iron-plated tip is more difficult to keep tinned than an all-copper one.

One common error is applying the flux-cored solder on the hot soldering iron tip. This procedure burns away the flux before the solder melts, thus preventing wetting of the metal being soldered. The flux-cored

ALLOY	MELTING TEMP. ° F
63/37 tin/lead	361
60/40 tin/lead	361-374
50/50 tin/lead	361-418
40/60 tin/lead	361-460
62/36/2 tin/lead/silver	354-372
96/4 tin/silver	430
95/5 tin/antimony	450-464
10/88/2 tin/lead/silver	514-576

Fig. 2. The most common solder alloys and their melting temperatures.

solder should only be melted on the heated metal surface so that there will be an adequate amount of flux on the hot metal to prepare the way for the solder.

The requirements for reliable soldering are: (1) solderable metal surfaces; (2) proper flux; (3) correct solder alloy; and (4) sufficient heat.

If all these requirements are met, soldering will become a simple, inexpensive method for joining metals rather than a tedious, esoteric task to be performed only by experts. ♦

COLUMBIA 4 CHANNEL SQ

Solid state SQ 4 channel adapter, 2 amps built in. Decodes 4 channel or synthesizes 4 channel. **\$35.00**

LED READOUTS \$20!

The price is not a mistake. We have some hobby variety with some segments out. Ukinbuyem for as low as **5 for \$1.00**

PHOTO STROBE

For use with most Instamatic cameras. With nicad battery and built-in charger. Never buy flash cubes again. **\$9.95**

AM—FM RADIO

For console installation, w/face plate, no knobs. Stereo amplifiers for tape or turnable playback. **\$15.00**

Pair of matching speakers w/xfmrs for above **\$5.00**

Please add postage for above.
Free Catalog

JOHN MESHNA JR.
PO Box 62, E. LYNN, MASS. 01904

CIRCLE NO. 10 ON READER SERVICE CARD

Now... the most enjoyable, do-it-yourself project of your life—a Schober

Electronic Organ!



You'll never reap greater reward, more fun and proud accomplishment, more benefit for the whole family than by assembling your own Schober Electronic Organ.

You need no knowledge of electronics, woodwork or music. Schober's complete kits and crystal-clear instructions show you — whoever you are, whatever your skill (or lack of it) — how to turn the hundreds of quality parts into one of the world's most beautiful, most musical organs, worth up to twice the cost of the kit.

Five superb models, with kit prices from \$575 to around \$2,300, each an authentic musical instrument actually superior to most you see in stores.

Get the full story FREE by mailing the coupon TODAY for the big Schober color catalog, with all the fascinating details!

The *Schober* Organ Corp., Dept. EH-9
43 West 61st Street, New York, N. Y. 10023

Please send me Schober Organ Catalog.

Enclosed please find \$1.00 for 12-inch L.P. record of Schober Organ music.

NAME _____

ADDRESS _____

CITY _____ STATE _____ ZIP _____

CIRCLE NO. 11 ON READER SERVICE CARD

PRECISION LAB POWER SUPPLY

BUILD THIS REGULATED SUPPLY
WHICH DELIVERS UP TO 30 V AND 1.2 A

BY C. R. BALL, JR.



EVERY electronics hobbyist and service technician needs a bench power supply. To obtain best results, the supply should be completely variable, from zero to the maximum voltage used in semiconductor circuits (usually 30 volts), and be capable of delivering enough current to carry normal loads (at least 1 ampere). In addition, the supply should have excellent regulation (both with power-line variations and load changes), minimum ripple and noise, automatic current limiting, and provisions for avoiding damage in case of inadvertent shorts.

The power supply described here meets these requirements. Its output is 0-30 volts with a line or load regulation of 0.02% or 1 mV; 0-1.2 A with line or load regulation of 0.2% or 1 mA. Transient recovery time is less than 25 microseconds, and ripple and noise are less than 0.25 millivolt rms. Cost is less than \$80.

Theory of Operation. The complete schematic of the power supply is shown in Fig. 1. However, its operation can be better understood by referring to the block diagram in Fig. 2. The ac power is applied

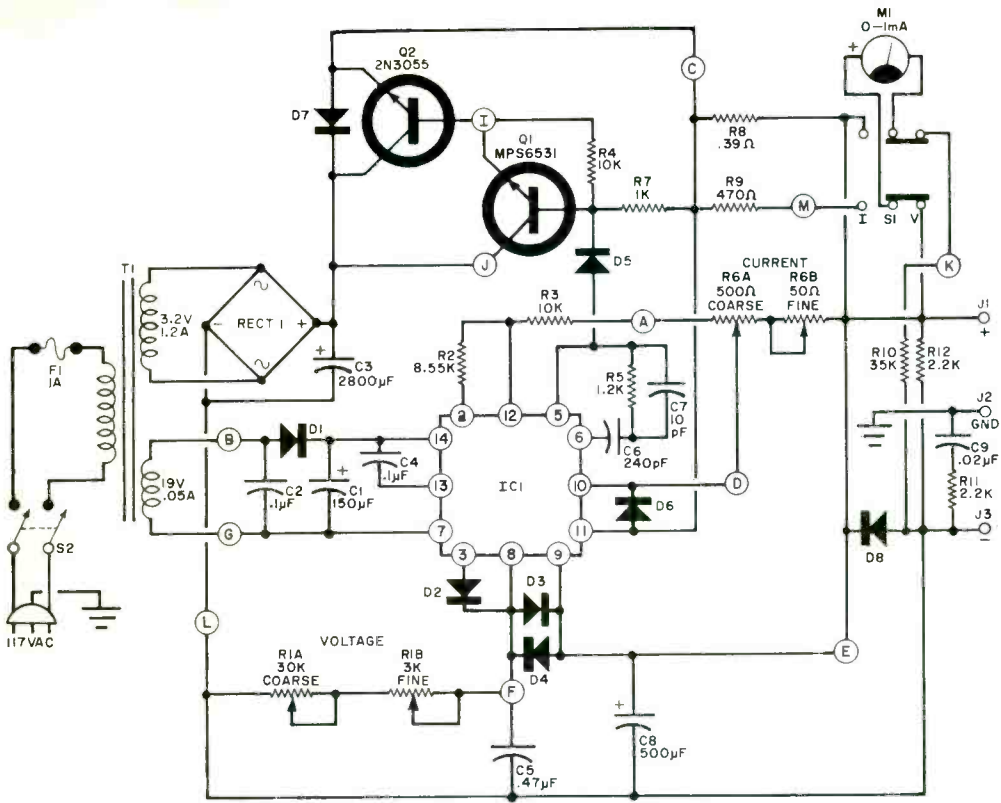

Fig. 1. The use of a special integrated circuit gives this power supply its excellent electrical characteristics. Circled letters indicate connections to board if you decide to duplicate prototype.

PARTS LIST

- C1—150- μ F, 50-volt electrolytic capacitor
 C2, C4—0.1 μ F, 50-volt disc capacitor
 C3—2800- μ F, 50-volt electrolytic capacitor
 D5—0.47- μ F, 50-volt Mylar capacitor
 C6—240-pF, 500-volt polystyrene capacitor
 C7—10-pF, 500-volt polystyrene capacitor
 C8—500- μ F, 50-volt electrolytic capacitor
 C9—0.02- μ F, 600-volt disc capacitor
 D1-D8—Diode (Mallory PTC205 or M2.54)
 F1—1A slow-blow fuse and holder
 IC1—Integrated circuit (Bevo 670-003)
 J1-J3—Five-watt binding post
 M1—0.1-mA meter (requires scale modification)
 Q1—Transistor (Motorola MPS6531 or HEP736)
 Q2—Transistor (Motorola 2N3055)
 R1—Dual concentric control, 30,000-3000 ohms
 R2—8550-ohm, $\frac{1}{2}$ -watt 1% metal film resistor
 R3, R4—10,000-ohm, $\frac{1}{2}$ -watt 5% resistor
 R5—1200-ohm, $\frac{1}{2}$ -watt 10% resistor

- R6—Dual concentric control, 500-50 ohms
 R7—1000-ohm, $\frac{1}{2}$ -watt 10% resistor
 R8—0.39-ohm, 10-watt 10% resistor
 R9—470-ohm, $\frac{1}{2}$ -watt 1% resistor
 R10—35,000-ohm, $\frac{1}{2}$ -watt 1% resistor
 R11, R12—2200-ohm, $\frac{1}{2}$ -watt 10% resistor
 RECT1—Bridge rectifier (Varo VS248)
 S1, S2—Dpdt switch

T1—Power transformer; secondaries: 32V at 1.2A and 19V at 0.05A (Bevo #101-050)

Misc.—Suitable chassis, heat sink (Delco 7281353), power transistor mounting hardware and insulator, silicone grease, capacitor mounting bracket, edge connector (Amphenol 143-010-03), three-wire line cord, wire, solder, etc.

Note—The following are available from Bevo Inc., P.O. Box 686, Salem, VA 24153: two PC boards (PS30A) at \$4.95; IC1 (670-003) at \$8.25; meter with special scale (650-004) at \$10.50; transformer (101-050) at \$9.70; complete kit of parts including all hardware, nameplates, wire harness, etc. (PS30K) at \$79.50.

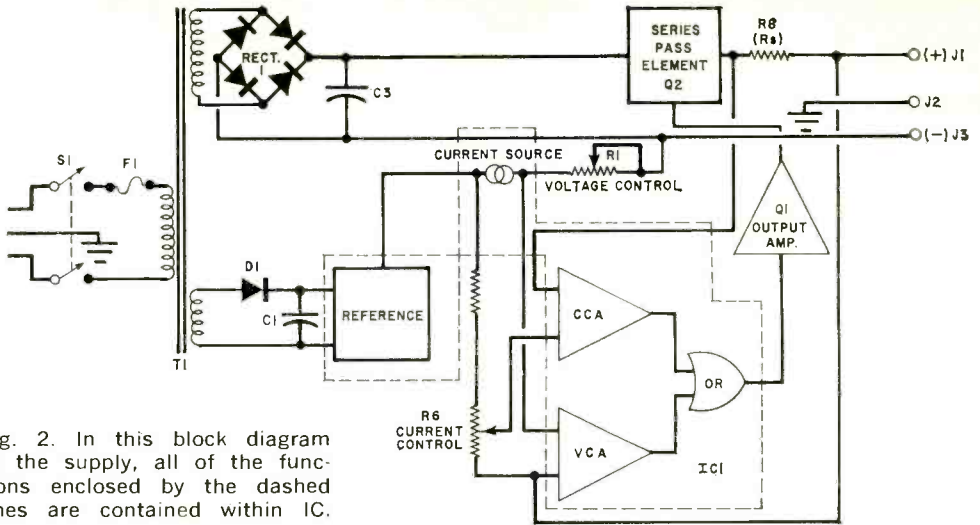
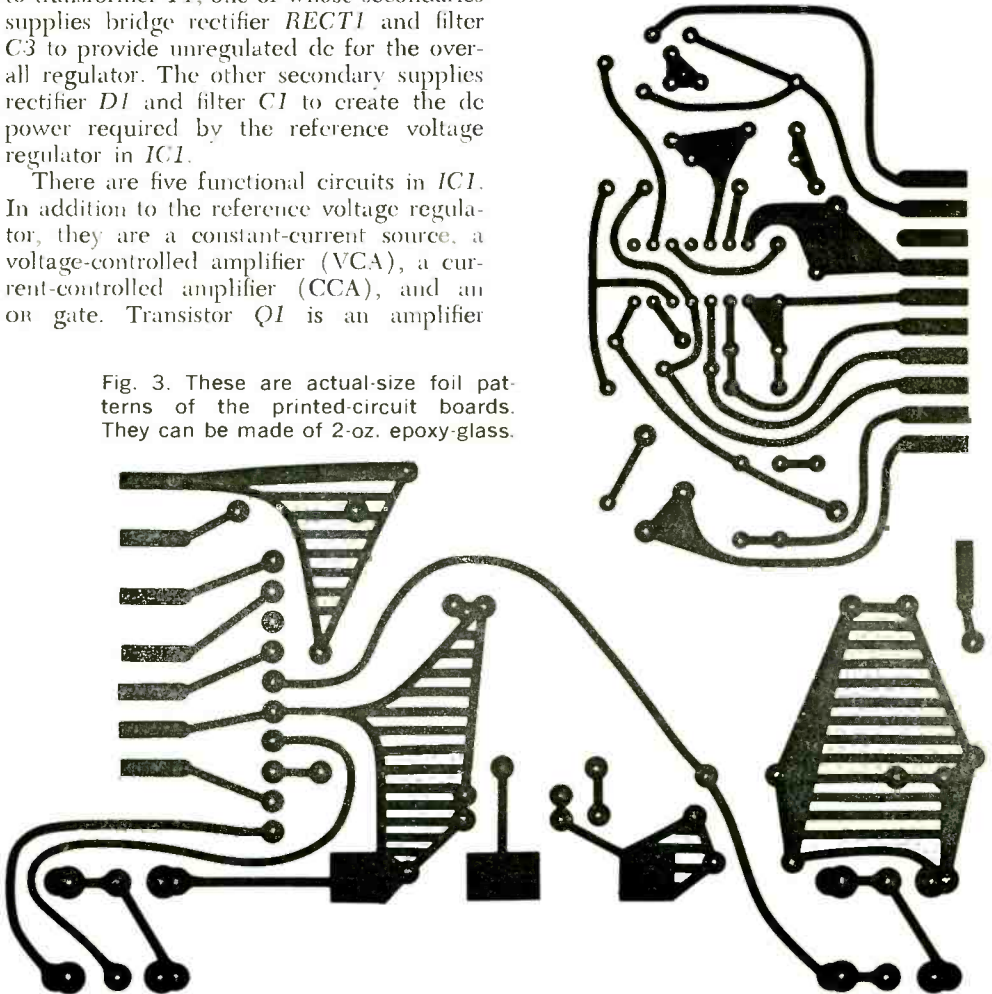

Fig. 2. In this block diagram of the supply, all of the functions enclosed by the dashed lines are contained within IC.

to transformer *T1*, one of whose secondaries supplies bridge rectifier *RECT1* and filter *C3* to provide unregulated dc for the overall regulator. The other secondary supplies rectifier *D1* and filter *C1* to create the dc power required by the reference voltage regulator in *IC1*.

There are five functional circuits in *IC1*. In addition to the reference voltage regulator, they are a constant-current source, a voltage-controlled amplifier (VCA), a current-controlled amplifier (CCA), and an or gate. Transistor *Q1* is an amplifier

Fig. 3. These are actual-size foil patterns of the printed-circuit boards. They can be made of 2-oz. epoxy-glass.



driven by the output of the on gate; and Q2 is the main series pass regulator.

The reference voltage regulator provides a stable reference voltage for the constant current portion, against which variations in other parameters are compared. The VCA functions as a voltage-error sensing amplifier. One input to this differential amplifier is connected to the positive output of the supply, which is compared to a reference voltage derived from a known current passing through a variable resistance (the voltage-control potentiometer). The preset resistance of the potentiometer multiplied by the known current flowing through it determines the reference voltage. Since the VCA tries to maintain the voltage between its two inputs at zero, any difference between them produces a change in the VCA output, thus causing either an increase or a decrease in the drive to Q2.

The CCA operates in a similar fashion, except that its inputs are derived from either side of a current-sensing resistor (Rs). Therefore, any difference between the voltage set by the current-control potentiometer and the voltage across Rs causes a change in the output of the CCA to increase or decrease the drive to Q2.

The on gate determines whether the voltage or current control sets the output of the power supply. If either the VCA or CCA calls for a change in drive to Q2, then that amplifier is in control. Output amplifier Q1 provides the necessary gain to drive Q2.

Fig. 4. How components are mounted on boards. The small one plugs into the edge connector on the big board.

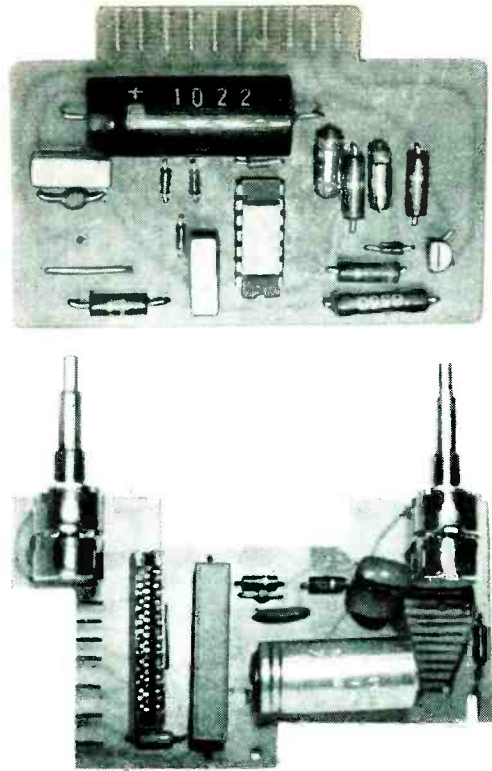
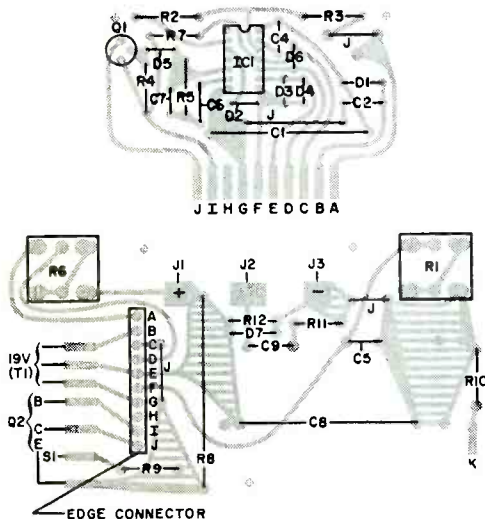

Fig. 5. Completed boards should look like these. The two dual potentiometers mount big board to chassis front.

Construction. The power supply can be assembled in almost any manner, but the "mother-daughter" PC board approach used in the prototype represents an easy assembly procedure and also allows for variations in the circuit, if desired. Foil patterns for the two boards are shown in Fig. 3. They should be fabricated on 2-oz epoxy-glass board and joined by a 10-pin edge connector.

The components are installed on the boards as shown in Fig. 4. The layout of the large board is such that several points are provided for the same connection of some components to allow for variations in size among manufacturers. Observe the polarities of polarized capacitors and semi-conductors. Dual potentiometers R1 and R6 should be mounted close to the board before soldering since they provide support for the front end of the large board. Clip off the excess potentiometer terminal lengths after soldering. The completed boards are shown in Fig. 5.

The boards and other components are

mounted in a suitable chassis as shown in the photograph. The heat sink for $Q2$ is mounted on the rear apron using thermal insulation (cork, rubber, etc.) between heat sink and metal chassis. When mounting $Q2$, use generous amounts of silicone grease and the insulator washers provided with the transistor.

The photographs show how the various controls, the meter, and output jacks are mounted on the front panel. Remember that the two power controls also support the mother board (with spacers and mounting hardware). The line cord is brought out through a grommeted hole in the back of chassis. The large filter capacitor ($C3$) is secured in a clamp mounted on the chassis, while the power transformer is mounted along the back of the chassis.

The scale of the meter must be modified to indicate from zero to 35 volts with each 5-volt step identified. On the current scale, each 0.2-ampere step should be marked from zero to 1.5 amperes.

Checkout and Use. Before putting the supply in operation, recheck all wiring and interconnections. Be especially careful with $Q2$ making sure that it is insulated from the heat sink and chassis and that it is properly connected.

Turn on the power and set $S1$ to the VOLT position. Set the concentric current

PROJECT EVALUATION HIRSCH-HOUCK LABORATORIES

The ripple was well within specs, typically from 135 to 250 microvolts depending on load and output voltage. The line regulation was excellent, with no perceptible change in output from 105 to 125 volts input. (We could detect as little as 1 millivolt if it had existed, since we used a stable reference voltage to buck out the supply voltage and a Triplet VOM on its 0.3-volt scale as a null meter.)

Load regulation was not as good as claimed. At 5 volts output, the 0.02% regulation would have corresponded to 1 millivolt, a barely detectable level. We measured a change of 18 millivolts from no load to 1.2 amperes, indicating a source resistance of 0.015 ohm. Good, but not as rated.

No measurements were made in the constant-current mode, but the constant-voltage to constant-current transition seemed to occur smoothly and as intended.

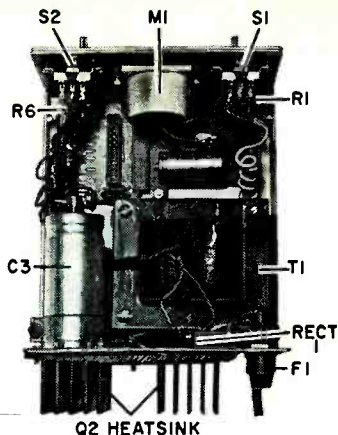

This shows completed supply except that the small board is not plugged into edge connector so that it doesn't hide other parts.

controls ($R6$) to about midrange; and rotate the concentric voltage controls ($R1$), noting that the meter indicates between zero and approximately 30 volts. Place $S1$ in the AMP position, short the output terminals ($J1$ and $J3$) and rotate the current controls. The output current should vary between zero and 1.2 amperes.

Set the current control about midrange, remove the short between $J1$ and $J3$ and connect a 15-ohm, 30-watt resistor across the output terminals. Place $S1$ in the VOLT position and slowly turn up the voltage control until the meter comes to a stop. Note both the voltage and current at this point. This is called the voltage-current transition point. Now, increase the voltage and note that the current does not change. (The system is now in current-regulation mode.) Rotate the voltage control back to the point where the voltage just starts to decrease. Then rotate the current control toward maximum and note that the voltage does not change. (The system is now in voltage-regulation mode.) If all these checks work properly, the supply is ready for use.

If you want to limit the current flow in an external circuit, short $J1$ and $J3$ and set the current control to the desired level. Remove the short and connect the supply to the circuit. No matter what happens in the circuit, the maximum current flow will be limited. As the voltage is brought up to the required value, the circuit current can be read off the meter. The supply can also be used for constant current by presetting the current and varying the voltage. ♦

adjusting your TV set for best color

Procedure used to get like-new picture

BY DAVID J. WATERS

A NEW color-TV receiver, once properly set up, is capable of producing sharp, clear color pictures because the three beams from the electron guns strike the centers of their respective color dots on the picture tube screen. Light coming from each dot under these conditions is a pure color, uncontaminated by the other two colors.

As the months go by, however, things begin to happen to the sharp, pure color. Tubes begin to age and other components like capacitors and resistors begin to drift off value. The aging and drifting worsen as time goes by. Fortunately, all color TV receivers are designed to permit adjustments that will satisfactorily compensate for component deterioration and other causes of color imperfection. In this article, we will discuss how to make some basic adjustments.

Purity Test and Adjustment. One of the major causes of loss of color clarity is a loss of purity. To test for color purity, tune your receiver for the best possible color picture, working with the fine tuning, aft (if any), tint, color, brightness, and contrast. Tune through all channels, looking for areas of color "blotches" common to all channel settings. If you note any such areas, color purity must be re-established.

Degaussing is the procedure used for re-

storing color purity. The only tool needed is a degaussing coil with a 10'-12' line cord and a momentary-action power switch.

Plug the coil's cord into an ac receptacle so that you can bring the coil right up to the front of the picture tube and also back away 8' or 10' directly in front of the tube. With the TV receiver turned off, hold the degaussing coil parallel to the center of the picture tube and begin making small circular movements with the coil. While the coil is in motion, activate and hold the power switch and continue to describe ever widening circles until you have covered the entire screen area of the picture tube. Then, still depressing the power switch, back away from the receiver about 8' or 10' and let go the switch.

A word of caution: A degaussing coil develops a powerful electromagnetic field that can destroy the speaker or the convergence magnets, as well as ruin a non-antimagnetic watch. So, do not bring a degaussing coil near the speaker or the rear of the receiver, and remove your wristwatch.

After you have completed degaussing the picture tube, turn on the receiver and tune in a color broadcast. Carefully recheck all areas of the picture for color impurity. If any such areas still exist, degauss the picture tube again.

While you are examining the picture, take careful note of how the colors are converged. Do this with the color control set to a "natural" level—not to saturation. If the colors are improperly converged, the outlines of figures against a background of contrasting color will reveal color "fringing." The fringe may be red, green, or blue and, if present, indicates that reconvergence is necessary. Note, however, that some mis-convergence is normal for all dot-triad picture tubes, especially at the corners and extreme top, bottom, and sides. So, if, at a normal viewing distance, the color fringing cannot be noticed, there is no need to re-converge the beams.

A note of warning is in order before proceeding. *Unless you are familiar with the procedures to follow when working around high voltages, do NOT perform the following steps—have a TV technician do them. Once the back is off of a powered receiver, dangerously high voltages are present at various locations; so, if you do not know what you are doing, don't gamble on getting a bad shock.*

Regardless of the need for convergence, purity adjustments must be made. Turn off the power from the receiver and remove its back. Turn the color control fully counter-clockwise. Then plug a cheater cord into the receiver's safety interlock and the other end into an ac outlet. Turn on the power and allow the receiver to warm up until a full raster appears on the screen. Prop a mirror up at a convenient distance and angle in front of the TV screen so that you can readily see the screen image while working behind the receiver.

Being careful to touch nothing else, go to

the back of the receiver and set the BLUE SCREEN, RED SCREEN and GREEN SCREEN controls fully counter-clockwise and the BLUE DRIVE and GREEN DRIVE controls to $\frac{1}{4}$ clockwise.

Referring to Fig. 1, loosen but do not remove the three wing-nuts located on the yoke assembly at the back of the picture tube. Grasping two of these nuts, ease the yoke backward (toward you) until a red "blob" of color appears approximately in the center of the screen. (You may have to advance the RED SCREEN control.) Center the blob with the tabs on the blue lateral assembly. Then slide the yoke forward (away from you) until the red area *just fills* the screen and tighten the wing-nuts.

Set the NORMAL/SERVICE switch to SERVICE and the KINE BIAS switch to the lowest setting that will permit the following two steps to be performed. Adjust the RED SCREEN control until a low-intensity red line appears horizontally across the face of the tube. Back off on the control until the line just disappears. Repeat these two steps with the BLUE SCREEN and GREEN SCREEN controls. Then set the NORMAL/SERVICE switch to NORMAL and alternately adjust the DRIVE controls for neutral grey shades in the black and white picture on the screen. Note that the white areas appear at your viewing distance to be white and not reddish, greenish, or bluish.

Color Convergence. Having determined that your receiver requires convergence, place a color bar/dot generator atop the receiver cabinet (or any convenient location if this is not practical), plug it into an ac outlet, and connect its r-f output cable to

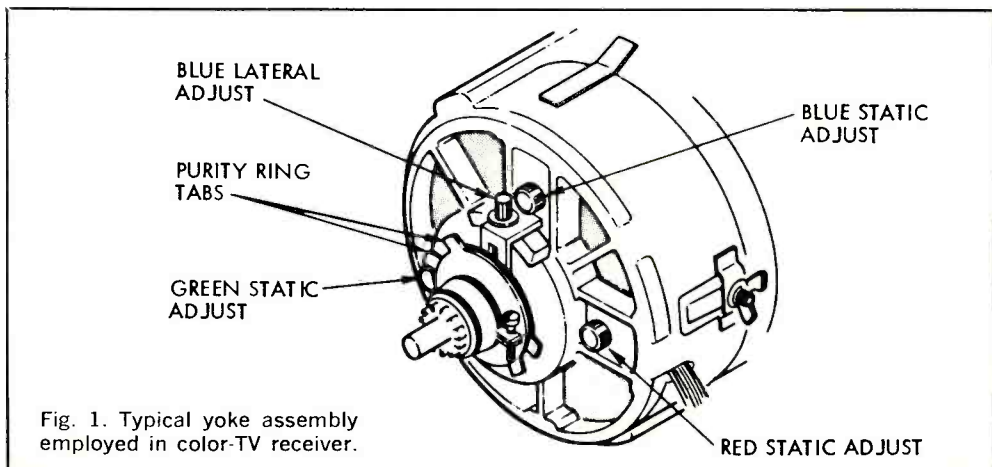

Fig. 1. Typical yoke assembly employed in color-TV receiver.

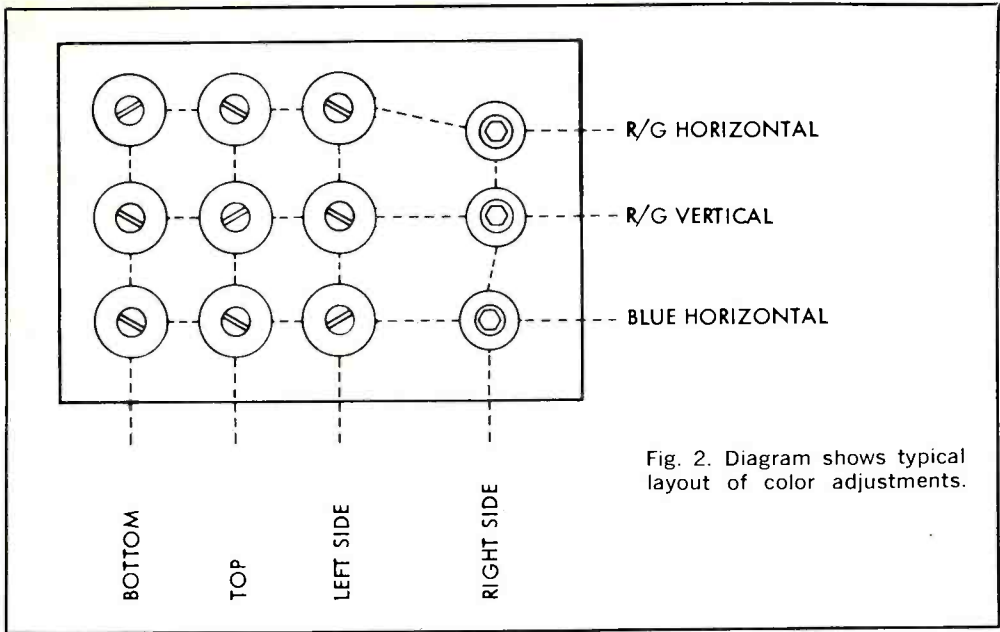

Fig. 2. Diagram shows typical layout of color adjustments.

the receiver's antenna terminals after first removing the lead-in cable. Tune the receiver to a vhf channel within the generator's range. Set the generator's pattern control to **DOTS** or **CROSSHATCH** and tune the channel control for a sharp, flutter-free display on the face of the picture tube.

Set the pattern control for **COLOR BARS** and adjust the **COLOR** and **TINT** controls on the receiver so that the fourth bar from the left is reddish-purple and the third bar is red. A green bar should appear at the extreme right on the screen. Switch to **DOTS**.

Locate the three static convergence controls on the yoke of the picture tube and adjust them so that the red, green, and blue dots merge into white dots in the *center* of the screen. Note that the blue control moves the blue dots up and down and the red and green controls move their respective dots diagonally in opposite directions. If the red and green dots converge and the blue dots are at the proper height but to the left or right, move the blue dots horizontally by operating the blue lateral control.

The dynamic adjustments are a bit more complicated to make since they interact, and each set is predominantly in control of only one quadrant of the picture tube's screen. Locate the convergence board and note the 12 controls with which you will be working, matching their locations with the layout drawing in Fig. 2. The three controls on the right are slug-tuned coils for which

you will need the appropriate tool for tuning.

The dynamic adjustment procedure is accomplished mainly through trial and error. Converging the dots at the bottom of the screen causes the convergence at the top to deteriorate, and vice versa. Accordingly, a little adjustment at a time (first one, then the other) will usually produce satisfactory results. In most cases, a compromise in misconvergence at the extremities will have to be made in order to keep the convergence in the all-important center of the screen as near to perfect as possible. You may also find that, to maintain perfect center convergence, you have to go back to the static (yoke) adjustments for touchup. Note, however, that perfect convergence will be obtained in only about $\frac{1}{2}$ to $\frac{3}{4}$ of the entire area of the picture screen. It will be progressively worse at the farthest extremes as mentioned earlier. This need not be an inconvenience, however; since, at normal viewing distance, the small error will appear to be slight, if not nonexistent. ♦

Editor's Note: The instructions for adjusting for color given here are generalized. Not all sets have the same adjustments or require the same procedure. If you can obtain the service data for your particular set, follow the instructions given there.

Reflex Enclosure Dimensions

BY E. G. LESCAULT

DESIGNING your own reflex speaker enclosure is really very simple (see "Rally Round The Reflex," PE, Nov., 1969) if you don't have to juggle numbers. The nomograph on this page lets you determine the optimum enclosure dimensions—without mathematics—for a given enclosure volume in cubic feet. The scale calibration marks are set up to provide direct readout of length, width, and depth in inches for a given volume, all

the while preserving the optimum 1:1.44:2.08 dimension ratio.

To use the nomograph, simply lay a straight edge down so that it intercepts the appropriate cubic-foot figure in the Volume column and the other three columns for the most convenient dimensions. For example, the line drawn across the nomograph indicates a length of 33", width of 22 $\frac{3}{4}$ " and depth of 15 $\frac{3}{4}$ " for a 7 cu ft enclosure volume. ♦

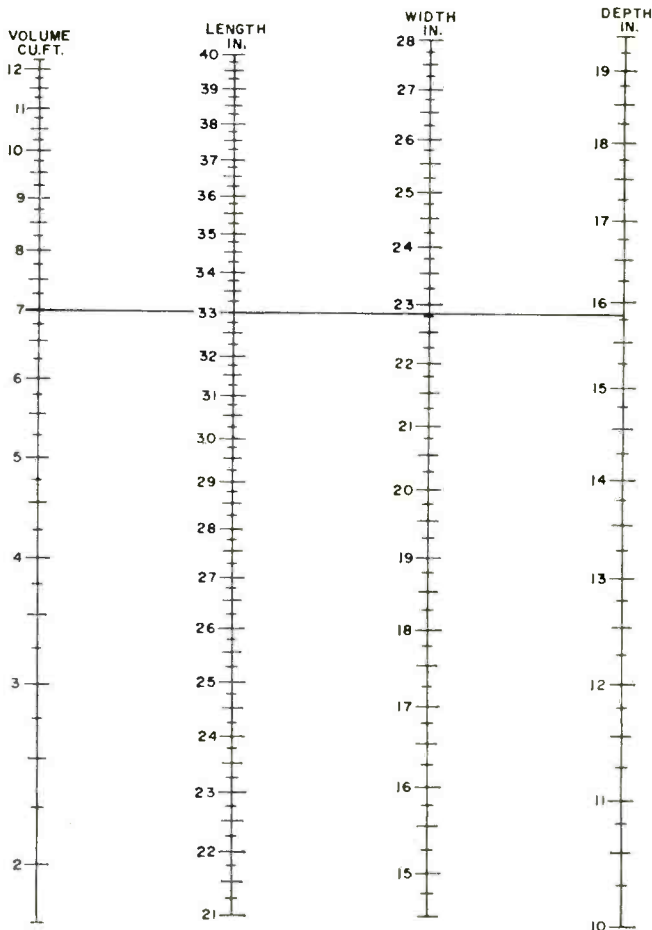



BUILD A PINK NOISE GENERATOR

CUT OUT NOISE POLLUTION AND KEEP YOUR COOL

Here is a unique device that masks disturbing noises by substituting the gentle "rushing" sound of pink noise. Self-contained, the pink noise generator can be assembled in less than an hour. Its masking effect should not be underrated.

EVERY FAN of spy movies knows that the best way to keep hidden mikes from picking up top-secret information is to repeat the information only while you've got a shower running. Why? Because the sound of the shower covers up the conversation. Probably any sound, such as jack hammers or rock and roll music would do, but a real pro spy will settle only for a shower because it simulates a thing called pink noise.

Pink noise is a special case of a large general class of signal called white noise. Whereas white noise is a Gaussian (equal probability) distribution of all possible frequencies, pink noise is a distribution which is weighted toward the audio spectrum.

Besides being able to mask outside sounds, white noise has some other interesting properties. For instance, many people find a rain storm relaxing; and, while other effects such as the high concentration of ionized air may contribute, at least part of the general feeling of well-being can be traced to the sound of the falling raindrops—a type of pink noise. The same is true of the sound of the ocean.

Some years ago a group of dentists experimented with the use of pink noise in-

BY JOHN S. SIMONTON, JR.

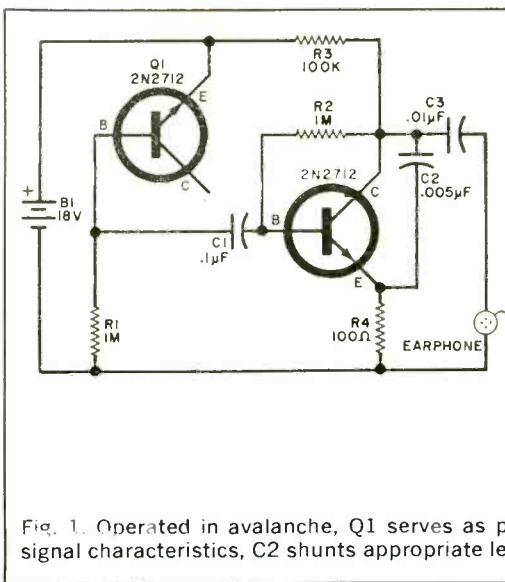

PARTS LIST

- B1—Two 9-volt transistor batteries connected in series
 - C1—0.1- μ F disc capacitor
 - C2—0.005- μ F disc capacitor
 - C3—0.01- μ F disc capacitor
 - Q1, Q2—2N2712 transistor (see text)
 - R1, R2—1-megohm, $\frac{1}{2}$ -watt, 10% tolerance resistor
 - R3—100,000-ohm, $\frac{1}{2}$ -watt, 10% tolerance resistor
 - R4—100-ohm, $\frac{1}{2}$ -watt, 10% tolerance resistor
 - Visc.—Crystal earphones (2); printed circuit board (optional); plastic or Bakelite case; hookup wire; solder; etc.
- Note—The following items are available from PAIA Electronics, Inc., P.O. Box 14359, Oklahoma City, OK 73114: etched and drilled printed circuit board for \$1.00; complete kit of parts, including PC board but not including batteries for \$6.95.

Fig. 1. Operated in avalanche, Q1 serves as pink noise source. To preserve constant-level signal characteristics, C2 shunts appropriate levels of high frequencies away from earphone.

stead of local anesthetics. The results were questionable but in some patients the noise seemed to create a definite reaction on the nervous system so that pain sensations were blocked. Finally, several rock and roll groups mix a little pink noise in with their recordings to add body to the sound—which may be why so many of them are unintelligible.

The point of all this is that, if you must work in a noisy environment and sometimes have trouble concentrating or if you're just "up tight," you might want to try the "Chatter Jammer," an inexpensive, shirt-pocket-size generator of pink noise that not

only keeps the noise out but will probably soothe your nerves as well.

Theory of Circuit Design. As can be seen from the schematic diagram of Fig. 1, the circuit of the Chatter Jammer is very simple. Transistor Q1 is a silicon type that has a low emitter-to-base breakdown voltage rating. The base-emitter junction is reverse biased by the two series-connected 9-volt batteries that make up B1. In this setup, the base-emitter junction is operated in an avalanche condition.

Resistor R1 in the base circuit of Q1 limits the current flow through the junction and also serves as the load resistor for the shot noise which results from the avalanche process. The random ac voltage fluctuations produced by the avalanche effect are coupled into a single common-emitter amplifier stage, Q2, through capacitor C1. Once the signal is amplified, it is coupled through C3 to the crystal earphones where it can be heard as a "rushing" sound similar to the sound you would hear if you held a seashell to your ear.

Capacitor C2 shunts some of the high-frequency signal amplitude away from the earphone. As a result, all sound frequencies reaching the earphone are at one signal voltage level, giving the sound its "pink" characteristic.

Construction. There are only a dozen parts that make up the circuit of the Chatter Jammer, including the earphones and

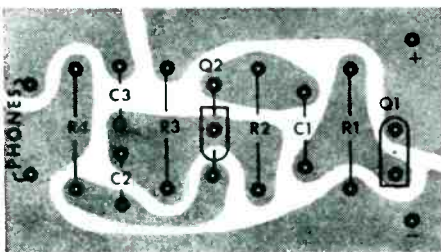
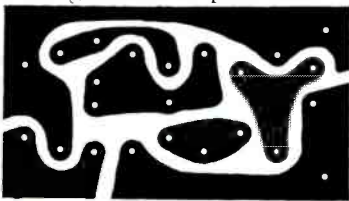

Fig. 2. PC board etching and drilling guide at top is shown full size. Directly above is component placement and orientation diagram.

battery pack. Add to this the fact that there are no high frequencies involved that could cause assembly problems, and you can readily see that just about any method of construction can be used. A printed circuit board, however, makes the project more compact and rugged. So, if you make your own circuit board, use the etching and drilling guide and components placement diagram of Fig. 2.

During construction, there is one point that you should be aware of. There is the remote possibility that the first transistor you try for *Q1* might not be a good noise source. Some transistors may not avalanche at all, while others may produce a very "grainy" sound. About 95 percent of all 2N2712 transistors will give the proper results; so, if you buy two for the project, at least one and probably both will work fine.

A power switch is not used on the Chatter Jammer for a very good reason. The current drain of the project's circuit is in the low-microampere region which means you will obtain essentially shelf life from the batteries even if the project is left on at all times.

Since the life of most 9-volt transistor batteries is so long, there is no reason why you should not simply solder leads from the batteries into the circuit instead of using battery clips that add to the project's cost. If you use stiff wire for the power leads, the leads can also support the circuit board.

The whole circuit, including board and batteries, fit neatly into a 3 $\frac{1}{2}$ " \times 2 $\frac{1}{2}$ " \times 1 $\frac{1}{2}$ " plastic or Bakelite box (see photos). First

drill a small exit hole for the earphone leads in one end of the box. Pass the leads of two crystal earphones through the hole and tie a knot about 2" from the free ends of the leads. Solder the leads to the appropriate points on the circuit board. (Note: Two earphones are used with the Chatter Jammer to increase the project's effectiveness. The addition of the second earphone will not affect the life of the battery supply.) A thin piece of Styrofoam can be cut to fit inside the case to keep the battery pack from working loose.

How To Use. Once the Chatter Jammer is operating properly, the only operation involved is to plug the earphones into your ears. You should immediately hear a rushing sound. Don't be surprised if it takes a minute or so to get used to the sound and feel of the earphones. After a short time, you will not be conscious of the rushing sound, nor will you be disturbed by extraneous sounds.

Musicians can try using the Chatter Jammer as a noise source by leaving the earphones off and connecting the output of the project to an unused high-impedance input on their instrument amplifiers. For a really strange effect, try passing the pink noise through a variable passband amplifier.

After you have used the Chatter Jammer for a while, you will be resorting to it whenever conditions prevent concentration or relaxation. It's sort of like having your own soothing rain sounds wherever and whenever you seem on edge. \blacklozenge

To keep batteries in place and prevent circuit board from rattling, place a piece of rigid foamed plastic, cut to size, under circuit board as shown.

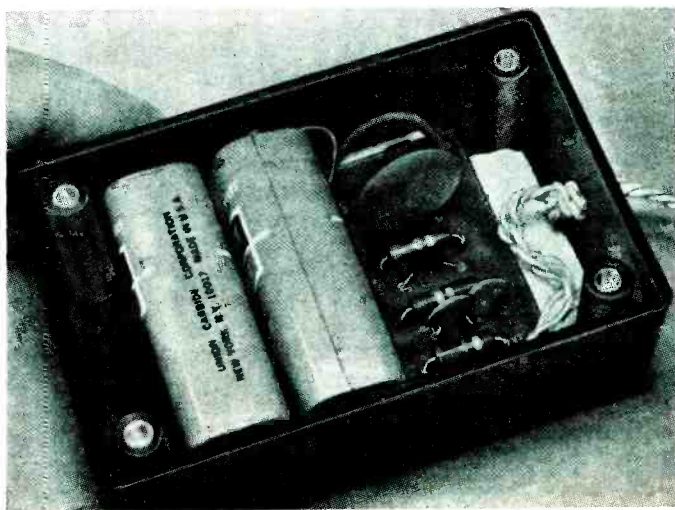

DESIGN YOUR OWN VOLTAGE REGULATOR

PUT A ZENER DIODE TO WORK

BY KEITH SCHUETTEL

MOST electronics experimenters have a single power supply that is usually used for all types of projects. The only problem is that the voltage may not be correct for every possible application.

Now, with just a resistor and a zener diode, coupled with a minimum of pencil work, you can make a fixed voltage source that is also well regulated. Of course, the power supply must be capable of delivering slightly more voltage than the expected regulated output level.

Simple Circuit. The circuit to be used is shown in the schematic. Essentially, it consists of a resistor and a zener diode feeding the output load. The zener diode is a semiconductor device that attempts to maintain a constant voltage (V_z) across itself and it accomplishes this by drawing the proper amount of current to maintain the voltage. The maximum current through the zener is determined by the power rating (P_z) of the diode and is calculated from

$$I_{Zmax} = (P_z/V_z)(0.9)$$

The 0.9 factor is included as a safety measure to avoid overheating.

Essential circuit is resistor and zener diode.

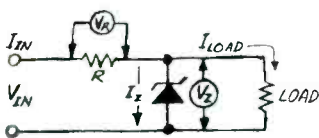

REQUIRED:

$$V_{IN} = 12V$$

$$V_z = V_{OUT} = 9V$$

$$I_{LOAD MIN} = 0$$

$$I_{LOAD MAX} = 150 \text{ mA} \\ (0.150 \text{ A})$$

$$P_z = V_z(I_{LOAD MAX} - I_{LOAD MIN}) 1.25 \\ = 9(0.150 - 0) 1.25 \\ = 1.69 \text{ WATTS} \quad \text{USE 2-WATT ZENER}$$

$$I_{Z MAX} = (P_z/V_z) 0.9 = (2/9) 0.9 \\ = 0.2 \text{ A}$$

$$R = (V_{IN} - V_z) / (I_{Z MAX} + I_{LOAD MIN}) \\ = (12 - 9) / (0.2 + 0) = 15 \Omega$$

$$P_R = (V_{IN} - V_z)(I_{Z MAX} + I_{LOAD MIN}) \\ = (12 - 9)(0.2 + 0) = 0.6 \text{ WATT} \quad \text{USE 1 WATT}$$

The resistor limits the current flow. The voltage drop across the resistor is equal to the difference between the input voltage and the output voltage or $V_{in} - V_z$. If V_z (the output voltage) is to be constant, and V_{in} is constant, then the voltage drop across the resistor must be kept constant. This will occur only if I_{in} is constant or $I_{in} = I_{load} + I_z$. Thus, the function of the zener diode is to control I_z so that $I_z + I_{load}$ remains constant under all load conditions.

The zener will function properly as long as the variation in load current is less than 90% of I_{Zmax} . When the load current is maximum, the zener current will be minimum and vice versa. It is a good practice to assume a minimum load current of zero if there is any chance that the load will be removed entirely. If this precaution is not taken, the zener diode may be destroyed.

The component values for the zener circuit are determined as follows:

1. Choose a zener diode having the desired voltage.

2. Determine the zener power rating from

$$P_z = V_z(I_{load max} - I_{load min}) (1.25)$$

The 1.25 protects the zener against overheating and assures a minimum zener current that will be more than 10% of the maximum current. This is necessary for proper operation.

3. Maximum zener current is determined from the formula given above.

4. The value for the resistor is determined for the case when zener current is maximum and load current is minimum or

$$R = V_R/I_{in} = (V_{in} - V_z) / (I_{Zmax} + I_{load min})$$

5. The minimum wattage of the resistor is calculated from

$$P_R = V_R I_{in} = (V_{in} - V_z)(I_{Zmax} + I_{load min})$$

A typical example is shown worked out in the drawing. Other values can be "plugged in" to achieve various ratings. ♦

LOW-COST CONVERGENCE GENERATOR

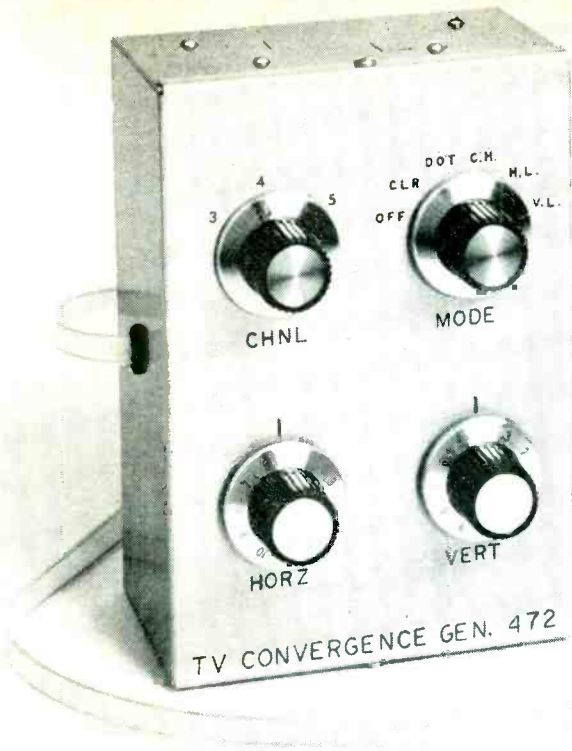

Produces a clear pattern, dots, crosshatch, or vertical and horizontal lines, using RTL logic.

BY MICHAEL S. CHING

CONVERGENCE is that wonderful process by which the TV technician makes your color TV picture look like new again. It is actually a relatively simple set of checks and adjustments that are first made when the set is built and, of course, whenever the picture tube is replaced. However, component aging and mechanical shocks, particularly in portables, result in a gradual loss of the original adjustments. The change often takes place so slowly that many people don't notice the symptoms—color splotches, color fading, color fringes around figures on black and white, etc.

These problems can be easily detected and possibly corrected when you use the

convergence generator described here. (Note that the generator is intended primarily as an aid in keeping the purity and convergence adjusted in an otherwise normally operating set. It is not meant to replace more complex color test equipment required to repair a malfunctioning set.) The generator is used simply by connecting it to the set's antenna terminals. The required adjustments can be made without removing the chassis from the cabinet.

How It Works. The generator circuitry can be divided into four major sections which use a combination of digital and linear techniques: sync oscillators, video, video/sync mixer, and r-f. An overall block diagram is shown in Fig 1.

The sync oscillator section consists of two UJT oscillators and their respective monostable multivibrators (one-shots). The circuit containing Q1, IC1A and IC1B (Fig. 2) produces horizontal sync pulses 6 to 9



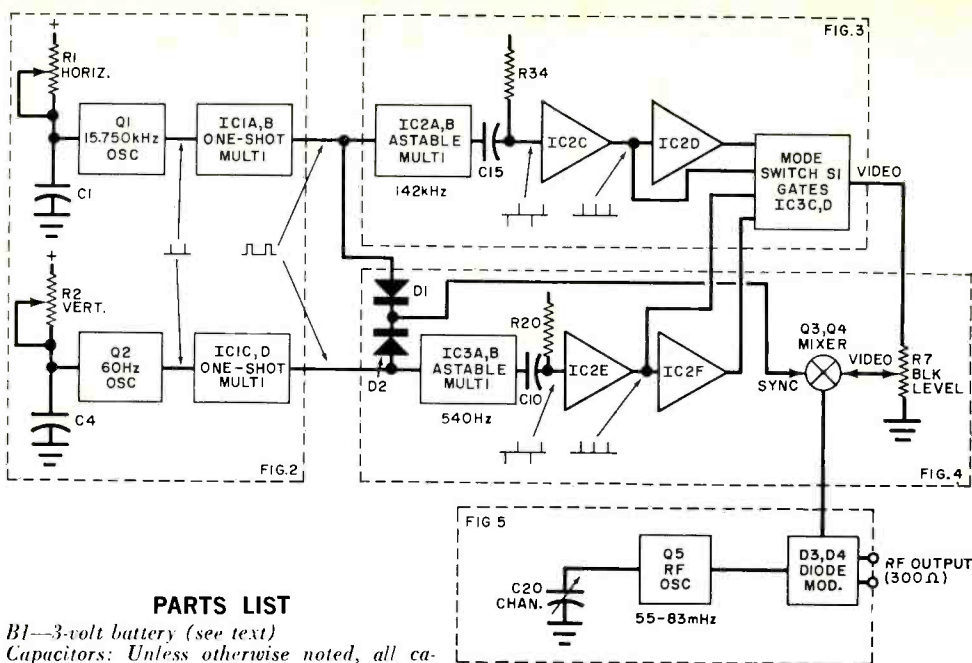

PARTS LIST

B1—3-volt battery (see text)

Capacitors: Unless otherwise noted, all capacitors are 10% polyester types, such as Sprague 225P or similar high-grade equivalent.

C1,C10,C24—0.0047- μ F

C2,C5,C7,C16—0.01- μ F

C3,C23—0.0022- μ F

C4—0.47- μ F

C6—0.22- μ F

C8,C9—0.033- μ F

C11,C19,C28—0.001- μ F

C12,C13,C14—100-pF mica (no substitute)

C15—10-pF mica (no substitute)

C17—200- μ F (minimum), 6-V electrolytic

C18—68-pF disc ceramic

C20—2.4-24.5-pF miniature variable (Johnson Type U, #189-569-1, or similar)

C21—33-pF disc ceramic

C22—10-pF disc ceramic

C25—7-45-pF ceramic trimmer (Centralab Type 825 or similar)

C26,C27—0.1- μ F

D1-D4—Silicon diode (1N914 or similar)

IC1,IC3—Integrated circuit (HEP570, MC724P)

IC2—Integrated circuit (HEP573, MC789P)

L1—5 turns of #20 bare wire, $\frac{1}{4}$ " diam. by $\frac{3}{8}$ " long. Tap 4 turns from collector end as described in text.

Q1,Q2—JIT (HEP310)

Q3-Q5—Transistor (2N3904, 2N4124, HEP55)

Resistors: Unless otherwise noted, all resistors are 10% carbon, $\frac{1}{4}$ or $\frac{1}{2}$ watt.

R1,R2—50,000-ohm potentiometer

R3,R4—500,000-ohm trimmer, horizontal mounting

R5,R6—25,000-ohm trimmer, horizontal mounting

R7—500-ohm trimmer, vertical mounting

R8,R14—1000-ohm

R9,R15—100-ohm

R10,R12,R17—4700-ohm

R11—5100-ohm

R13—15,000-ohm

R16—3900-ohm

R18—6800-ohm

R19,R34—39,000-ohm

R20,R24—22,000-ohm

R21—10,000-ohm

R22—47-ohm

R23,R25,R30—330-ohm

R26,R29—1500-ohm

R27,R28—680-ohm

R31—470-ohm

R32—27,000-ohm

R33—33,000-ohm

S1—4-pole, 6-position non-shorting rotary switch (Centralab PA-2011 or similar)

Misc.—Suitable chassis (7" x 5" x 3" will do but will not hold optional size D cells); 14-pin DIP sockets (3); TO-18 or TO-5 socket (5) (PC board is designed for 0.280" pin.); battery holder (2) for 3 penlite (AA) cells (Keystone #171) or optional holder for 2 size D cells (Keystone #176).

Fig. 1. This is the logic flow diagram of the convergence generator. The boxes in dashed lines show the four major sections: at left, the sync oscillators; upper right, horizontal drive; below that, the vertical drive; and, lower right, the r-f section. Some typical waveshapes are also shown to indicate circuit operation.

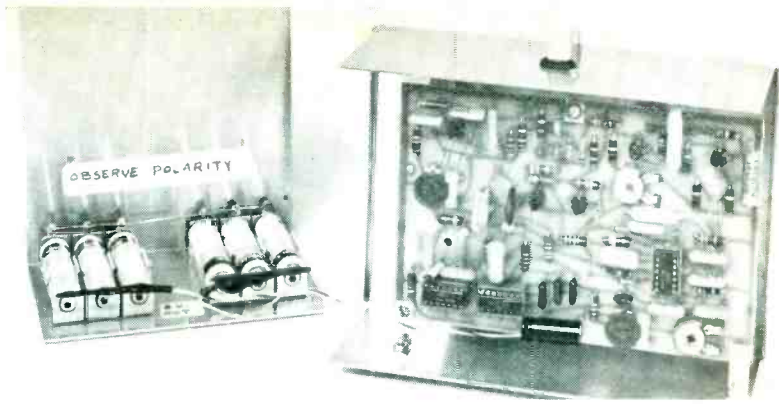

Six AA cells, wired to provide three volts, were used in the prototype.

microseconds wide at a pulse repetition frequency of 15.750 kHz. Capacitor $C1$ charges through resistors $R1$ and $R10$. When the voltage across $C1$ reaches the peak point voltage of the UJT (about 2.4 volts), the UJT makes a rapid transition into the negative resistance region, resulting in the discharge of $C1$ through the emitter- $B1$ junction. The positive spike appearing at base one is coupled to the IC dual-NOR gate one-shot for shaping into a pseudo-horizontal sync pulse. The output of a NOR gate is high (about 2.9 V) only if both inputs are low (less than 0.4V). For all other input conditions, the output is low (less than 0.3 V). When two NOR gates are connected as shown in Fig. 2, gate $IC1A$ is biased on (output low) and gate $IC1B$ is biased off (output high). A positive pulse from the UJT causes the output of $IC1B$ to switch to the low state, pulling terminal 13 of $IC1A$ down through capacitor $C3$. With both inputs of $IC1A$ now low, its output is high. The one-shot remains in this state until $C3$ has charged to above 0.4 V (6 to 9 microseconds), at which time the one-shot returns to its original state. This sequence is repeated for each triggering spike from the UJT, 15,750 times per second.

The vertical sync oscillator is similar to the horizontal except that the output pulses are about 0.5 millisecond wide with a pulse repetition frequency of 60 Hz.

The video section consists of horizontal and vertical astable multivibrators, RC differentiators, and logic gates. The horizontal astable ($IC2A$ and $IC2B$ in Fig. 3) is

synchronized to the horizontal frequency through $C11$, $R3$, and $C12$. Its output is thus fixed at an integral multiple of the horizontal line frequency of 15.750 kHz. Potentiometer $R5$ and resistor $R32$ set the output frequency by controlling the charging current to $C14$. For the component values shown in Fig. 3, the nominal frequency is

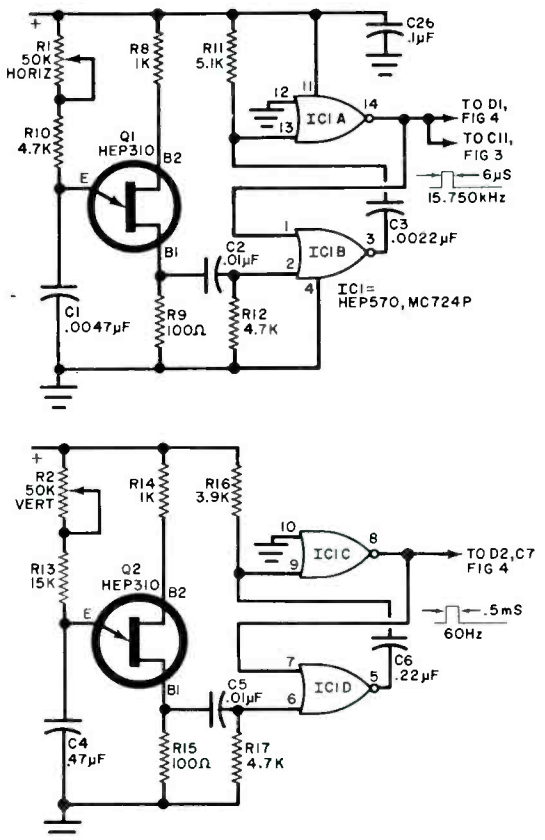

Fig 2. Horizontal and vertical oscillators feed one-shot multivibrators.

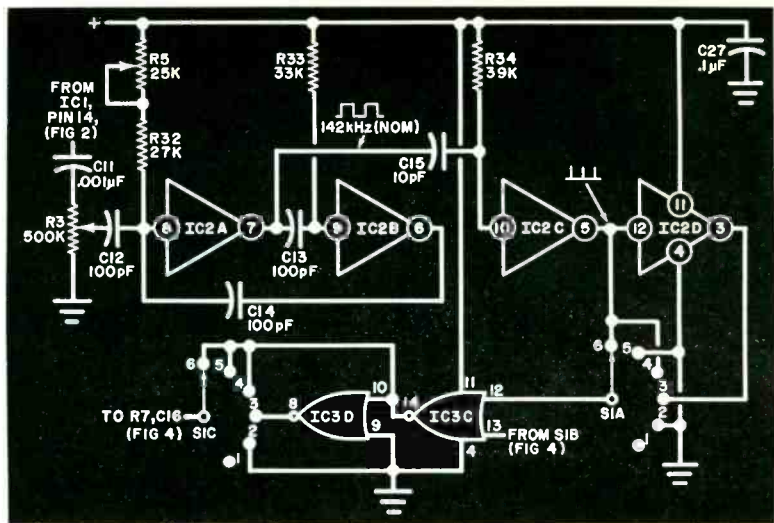

Fig. 3. Horizontal astable output determines width of vertical lines.

142 kHz (nine cycles between horizontal sync pulses). The 142-kHz rectangular pulses are differentiated by *C15* and *R34*. The resulting spikes are shaped and inverted by *IC2C*. The width of the output spikes from *IC2C* determines the width of the vertical lines on the TV screen.

A second inversion for the dot pattern is performed by *IC2D*.

The vertical astable (Fig. 4) is similar except that it is synced to nine times the frequency (540 Hz) of the vertical oscillator. The rectangular, 540-Hz pulse train is differentiated by *C10* and *R20* before shaping and inversion by *IC2E*. The width of the pulse from *IC2E* determines the width of the horizontal lines on the TV screen.

Generation of the actual video waveform associated with each of the five display modes is accomplished by sections of *S1* and NOR gates *IC3C* and *IC3D*. The video output waveform is then combined with the sync pulses at the common-collector junction of *Q3* and *Q4* (Fig. 4).

The sync pulses are added to the video waveform to produce a composite wave with negative-going sync pulses and positive-going video spikes. Diodes *D1* and *D2* comprise a diode gate so that either horizontal or vertical sync pulses can turn on *Q3*. With *Q3* saturated, its collector is at a potential less than 0.3 V. In the absence of either horizontal or vertical sync pulses, *Q3* is cut off and the collectors of *Q3* and *Q4* rise to a voltage determined by the setting of *R7*. (Thus *Q4* is biased in its linear region.)

When the video logic signal is high, *Q4* is biased to produce approximately 1.5 V at its collector. When the logic signal is low, *Q4* is cut off and its collector rises to 3.0 V. If the resulting composite video waveform were applied to the appropriate stage in the receiver's video amplifier section, the generator's test pattern would appear on the screen. However, to preclude the need to make internal connections to your set, the generator contains an r-f section.

The r-f section consists of an oscillator and a diode modulator (Fig. 5). Oscillator *Q5* is operated in the tapped Hartley configuration. The frequency is adjusted by *C20* and trimmed by *C25*. The r-f output is coupled by *C19* to the diode modulator.

With a high signal (3 volts) applied through *R31*, the output terminal has a low ac impedance to ground through *D4* (forward biased) and *C22* and a high impedance to the r-f oscillator due to diode *D3* (which is reverse biased).

When the modulating waveform goes low (less than 1.5 volts), diode *D4* is cut off and diode *D3* conducts. This allows the flow of radio-frequency current from the oscillator to the output terminal. The negative modulation convention used in American TV broadcasting translates an increase in the r-f amplitude into a decrease in brightness of the trace. In this way, the complex modulating signal is converted into a black-and-white pattern on the TV screen.

Construction. A printed circuit board us-

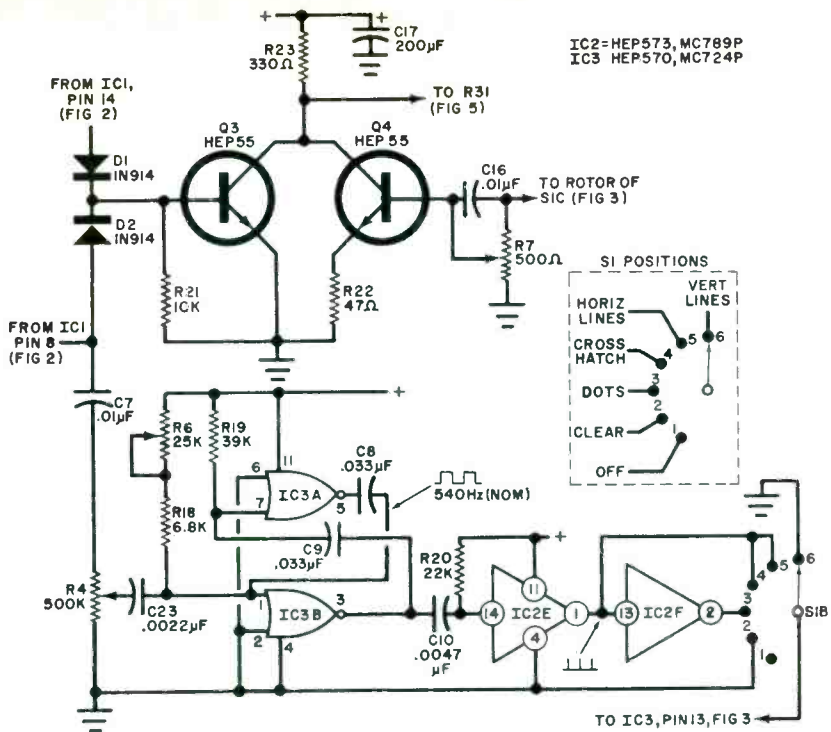

Fig. 4. A 540-Hz oscillator driven by vertical determines horizontal line width.

ing the pattern shown in Fig. 6 is recommended. The dots for diodes *D1* to *D4* designate the cathode ends. Diode cathodes can be identified by the end marked with a line or a dot. Be sure to observe polarities, especially on *C17*. Sockets should be used for all the semiconductors and IC's. Use heat sinks for *D1-D4* when soldering.

Note that *R1* and *R2* are wired so that resistance decreases in the clockwise di-

rection. Use minimum-length leads of about #22 solid wire. Use short lengths of stranded wire to connect the battery holder. In the prototype, two triple penlite-cell holders were used. These are OK for light usage of the generator (about ½ hr each time). If you expect heavier usage, two D cells will be needed—in an optional holder.

To wind *L1*, use any 1-watt carbon resistor as a form and five turns of #20 bare

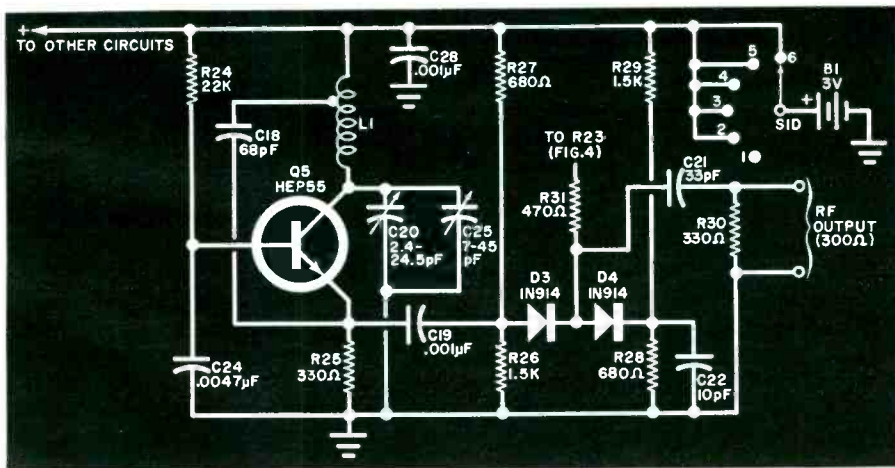
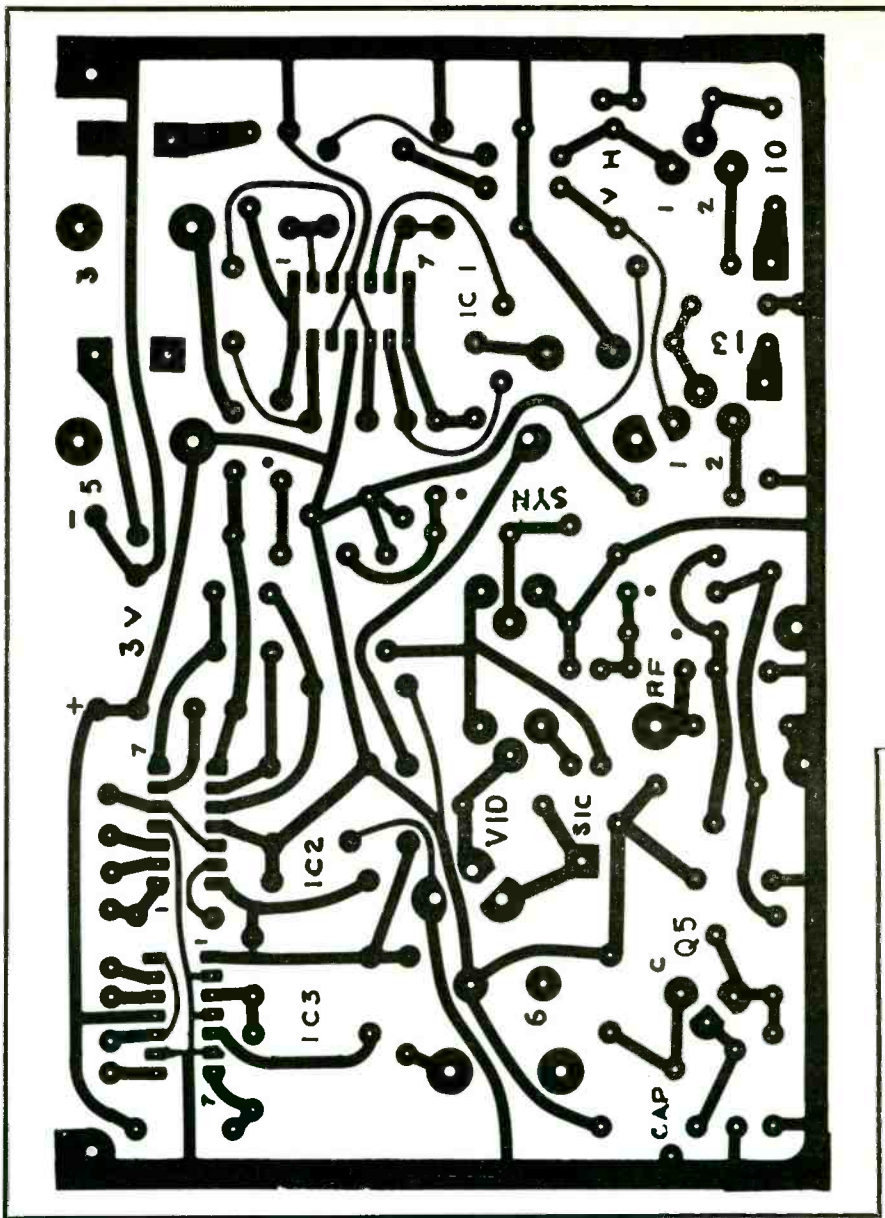

Fig. 5. Output of r-f oscillator and dual-diode modulator circuit drives the TV set.



wire (close-wound, with one turn touching the other). Then carefully spread the coil until the ends are $\frac{3}{8}$ -inch apart. Bend the end leads to the proper angle and remove the resistor before mounting the coil. Before the coil is soldered to the board, solder one lead of *C18* to the coil, four turns from the end connected to the collector of *Q5*. Note that this lead of *C18* does not go through the board, but directly to the coil.

The stationary plates of *C20* are connected to the collector of *Q5*; and the rotating plates to the ground bus on the

board. These two points are marked "CAP" in Fig. 6. Capacitor *C25* is soldered directly across *C20*.

Operation. Before turning on the generator, check the battery polarity and voltage. There should be 3.0 V between the positive side of the battery and ground on the board. To check the completed generator, connect it to either a black-and-white or a color TV set. (Because of the very low r-f power output and the dc blocking capacitor *C21*, the generator cannot damage the

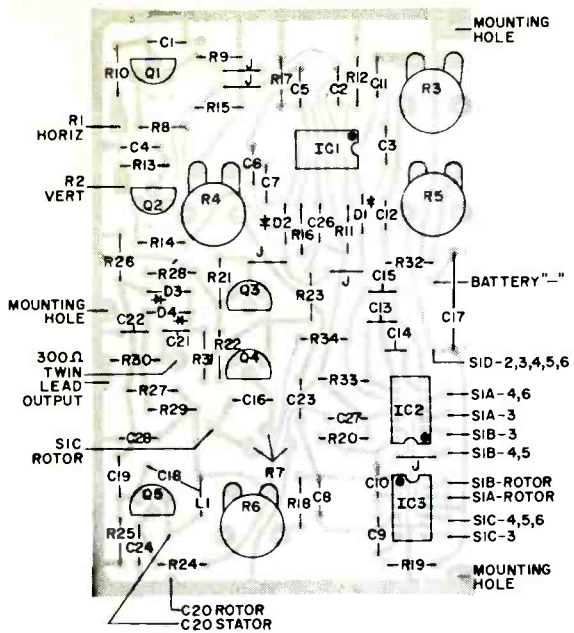

Fig. 6. The actual-size foil pattern (at left) and component installation (above).

TV set, even if the generator is not properly adjusted.)

Before getting into the operation of the generator, let's summarize the front panel controls and their functions. First, there is the **MODE** switch (*S1*). Besides turning the power on and off, it is used to select one of five displays: clear white screen (**CLR**), dot array (**DOT**), crosshatch (**CH**), horizontal lines (**HL**), and vertical lines (**VL**). The **CHNL** control varies the r-f carrier frequency over the range of three vhf channels (18 MHz). The **HORIZ** control varies the frequency of the horizontal sync oscillator about a nominal 15.750 kHz. The **VERT** control varies the frequency of the generator's vertical sync oscillator about a nominal 60 Hz. When adjusting either the **HORIZ** or **VERT** control, you may find more than one setting which results in sync of the pattern. Use the setting that results in the most stable display.

Make the following preliminary potentiometer adjustments:

1. Set *R7* about $\frac{2}{3}$ up from the grounded end. This potentiometer sets the black level of the composite TV signal.
2. Set *R4* fully counterclockwise.
3. Set *R3* fully clockwise.
4. Set *R5* and *R6* to midrange.

5. Disconnect the vhf antenna from the set and attach the generator to the antenna terminals on the set.

6. Turn on the TV set and put it on either channel 2 or 3, whichever is unused in your area. Turn the generator **MODE** switch to **CLR**.

7. With the plates of *C20* (**CHNL** control) fully meshed, adjust trimmer *C25* until the test signal from the generator appears on the screen with little or no buzzing from the set. This should be a clear raster—a completely white screen. Whether it is or not, continue to the next step.

8. Turn the **MODE** switch to the **HL** position. Adjust the **VERT** control to stop any vertical motion of the test pattern. Adjust the **HORIZ** control to eliminate any diagonal lines or "tearing" of the pattern. You should now see horizontal lines.

9. Touch up the adjustment of the **CHNL** control to eliminate any noise and to provide the clearest display. You may now prefer to decrease the TV's brightness control and increase the contrast to get white horizontal lines on a black background.

10. Trimmers *R4* and *R6* are used to set the stability and number of horizontal lines, respectively, though there will be some interaction between them. Adjust them for 9 or 10 horizontal lines and the best stability. Use the **VERT** and **HORIZ** controls to maintain vertical and horizontal sync as necessary.

11. Turn the **MODE** switch to the **VL** position. If vertical lines do not appear, touch up the **HORIZ** control.

12. Trimmers *R3* and *R5* are used to set the stability and number of vertical lines. Adjust them for 9 or 10 vertical lines and the best stability.

13. Turning the **MODE** switch to the **CH** position should now produce a 9 by 9 or 10 by 10 crosshatch pattern. Touch up the adjustment of the **CHNL**, **HORIZ**, and **VERT** controls as necessary. Trimmer *R7* may be reset slightly to provide the best balance between sync stability and pattern contrast.

14. Turning the **MODE** switch to **DOT** or **CLR** should produce a 9 by 9 (or 10 by 10) array of dots or a clear raster, respectively.

Always turn the **MODE** switch off when not using the generator.

Once the potentiometers on the board and *C25* have been set, the cabinet can be closed. Mark the positions of the **HORIZ** and **VERT** dials where sync was obtained for future use. ♦

SIMPLE SOLID- STATE CIRCUITS for the Experimenter

BASIC APPROACH ENABLES
ANYONE TO "ROLL HIS
OWN" AMPLIFIER

BY JIM HUFFMAN

YOU DON'T have to be a mathematical genius to design a simple solid-state amplifier. All you have to do is follow some basic rules, cut-and-try a little, test the circuit, and there it is! The mathematics involved in complete, top-level circuit design require the knowledge of a graduate engineer; but, unless the circuit is critical, there are some shortcuts that can be used by the serious electronics experimenter. These shortcuts yield "ballpark" figures that work well with components having 5% or 10% tolerances.

To explain what we mean by shortcuts and simplicity, we will use as an example the design of a microphone preamplifier. In this design, math is at the high school level, and Ohm's Law is the most complicated formula involved. All the designer has to

do is "plug in" the numbers necessary for his particular application.

Preamplifier Design. Suppose you want a microphone preamplifier that will match a low-impedance dynamic mike to a modulator or power amplifier with an input impedance of one megohm. (In other words, you want to make the dynamic mike "look" like a crystal mike.) Note, however, that the procedure described here could be used for matching an input device of any impedance to any circuit impedance simply by changing the necessary figures and using the appropriate transistor.

The design is accomplished in eight easy steps:

- 1. Write down all the pertinent facts about the circuit (see Fig. 1). It was de-

CIRCUIT FACTS:

1. MUST USE A 9-VOLT POWER SUPPLY
2. INPUT IMPEDANCE IS 3000 OHMS (DYNAMIC MIKE)
3. OUTPUT IMPEDANCE MUST BE 1 MEGOHM
4. FREQUENCY RANGE FROM 100 TO 3000 Hz

Fig. 1. Write down basic circuit facts.

termined (by tests) that the output of a crystal mike hits a maximum of 0.5 volt (roughly that of a crystal phonograph pick-up). The dynamic mike was connected to a VTVM, and a no-load output voltage of 0.1 volt was measured when speaking loudly, so a normal level of 0.05 volt was used. Thus, the voltage gain required of the amplifier is about 10 (0.5/0.05). Since these are very rough approximations, a final voltage gain of at least 20 was decided upon.

SEMICONDUCTOR FACTS:

2N697
SILICON
NPN
 $\beta = 40-120$ AT 150 mA
 $V_{CE} = 40$ VOLTS
 $f_T = 40$ MHz
 $Q_{PER. FREQ} = \frac{40}{\beta(HIGH)} = \frac{40}{120} =$
0.33 MHz (COMMON EMITTER)

Fig. 2. Consider transistor characteristics.

- 2. Write down all available facts about the transistor. Since we have a 2N697 in our junk box, we decide to try it (see Fig. 2). The 2N697 is silicon, so it is stable with temperature. It is an npn and has a beta between 40 and 120 when the current is 150 mA. Usually, we use the lowest beta

$$Z_{IN} \geq 3000 \Omega$$

$$Z_{OUT} \leq 1 \text{ MEGOHM}$$

$$\text{VOLTAGE GAIN} \geq 10$$

- CAN'T USE → 1. COMMON COLLECTOR (EMITTER FOLLOWER) - NO GAIN
 CAN'T USE → 2. COMMON BASE - LOW INPUT Z
 3. COMMON EMITTER
 4. COMMON COLLECTOR - $M \geq$

Fig. 3. These are circuit parameters.

figure, but since the 150 mA specified for the 2N697 is considerably more than we need, we use a beta of 50. Since we are using a nine-volt supply and the breakdown voltage, V_{CE} , is 40, the device should be safe.

The gain-bandwidth product, f_t , for the 2N697 is 40 MHz. Dividing this value by the highest beta (120) gives a maximum frequency of 330 kHz, when the device is used in the common-emitter configuration. This is well above the 3-kHz maximum frequency required.

• 3. Decide on a configuration, using the facts in Fig. 1. The parameters selected are shown in Fig. 3. The input impedance may be hard to achieve with a common-base amplifier; and since the voltage gain is less

Fig. 4. Two circuit configurations.

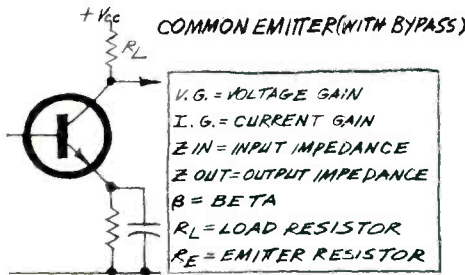

$$V.G. \cong (R_L / Z_{IN}) \beta$$

$$I.G. \cong 0.9 \beta$$

$$Z_{IN} \cong \beta (26 / I_E (\text{MAX}))$$

$$Z_{OUT} \cong R_L \quad (A)$$

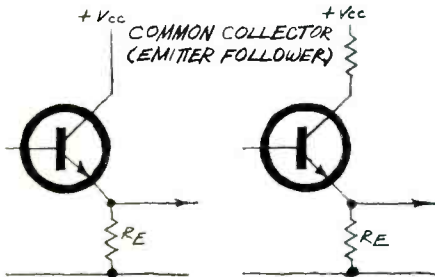

$$V.G. \cong 1$$

$$I.G. \cong 0.9 \beta$$

$$Z_{IN} \cong \beta R_E$$

$$Z_{OUT} \cong Z_{IN} / \beta \quad (B)$$

than unity, the common-collector approach can't be used. The common emitter (Fig. 4A) looks good except that the desired input impedance is higher than that normally associated with a common-emitter circuit. So we have to add another stage (emitter follower) to raise the input impedance (Fig. 4B).

• 4. Now we can draw a preliminary design, such as that shown in Fig. 5. The battery supply is included, capacitors are marked for polarity, and components are numbered for reference.

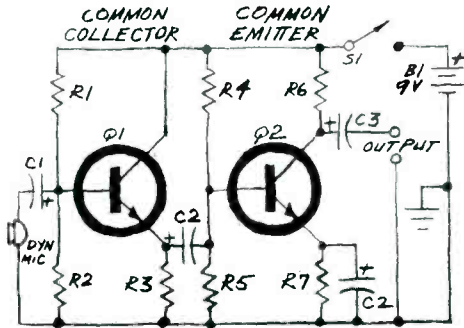

Fig. 5. Draw basic circuit diagram.

Note that single-battery bias is used. This bias method provides better results as far as temperature stability and other factors are concerned. Also, contrary to some beliefs, this is the easiest system to design.

• 5. Calculate the data as shown in Fig. 6, using the data supplied in Fig. 4A for the common emitter stage and Fig. 4B for the emitter follower.

The most critical parameter for the emitter follower is the output impedance. The latter is approximately equal to the input impedance divided by beta, or 3000/50. So the output impedance (or the emitter resistance) should be 60 ohms or more. This is easy to achieve since the input impedance of the next stage is probably greater than 60 ohms. The actual emitter resistor is R_3 , and to avoid as little loss as possible, we choose it to be ten times the 60 ohms decided on for the emitter resistance. Thus, $R_3 = 600$ ohms or more. The "or more" tells us which way to go if we have to use other than a 600-ohm resistor.

For stability, R_2 should be about 10 times R_3 or 6000 ohms.

The value of R_1 depends on the value of bias current chosen. Since the stage is a voltage amplifier, and since a 9-volt supply is used, there should be about 4 volts across R_3 (including a 1-volt drop across the

transistor). Thus, the voltage at the base of the emitter follower should be four volts when there is no input signal. To achieve this drop across R_2 , R_1 has to be 7500 ohms.

For the common emitter stage, R_7 is a non-critical value in most cases and can be "picked out of the air." If the wrong value is chosen, we will find out later in the design. A good value to choose for R_7 is 1000 ohms.

In this stage, as before, R_5 is 10 times R_7 or 10,000 ohms.

The value for R_6 , which must be chosen before R_4 can be determined, will be approximately equal to the output impedance of the amplifier. The modulator or power amplifier input is a voltage amplifier because of the high impedance. Since the output of the preamp is required to be a voltage generator, the output impedance can be much less than the input impedance of the modulator or power amplifier. The stage need not transfer maximum power, only maximum volts, so the impedances need not match. Essentially, the entire output voltage from the common emitter stage will be felt at the input of the amplifier if the output impedance is less than about 1/10 of the input impedance of the amplifier. In fact, 1/100 would be a better figure, so R_6 is chosen to be 10,000 ohms. Normally, at

Fig. 6. Determine the resistor values.

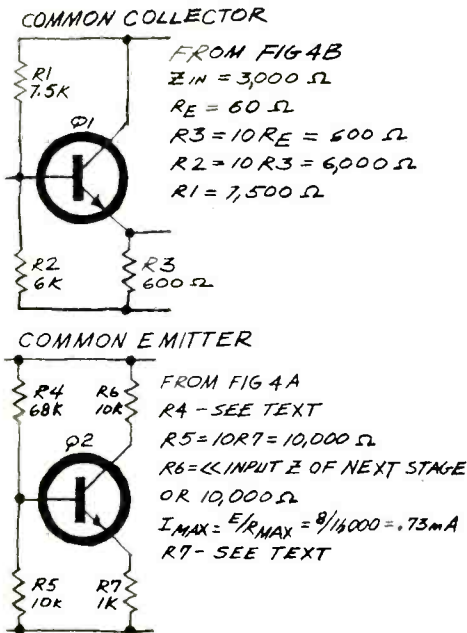

this time, R_6 would be considered in regard to the desired voltage gain. A quick check shows that the 10,000-ohm value provides a gain of over 20.

To make sure that the output of the amplifier is class A (and since Q_2 is a current amplifier,) the bias through R_6 is chosen to be half of its maximum value. The maximum current through R_6 will be

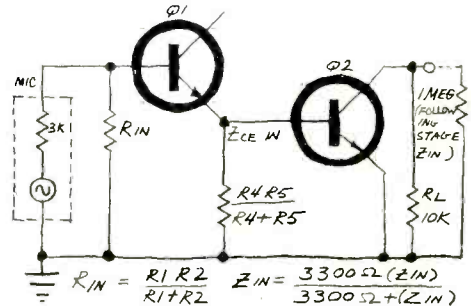

Fig. 7. Convert to equivalent ac design.

about 0.73 mA (1-volt drop in the transistor) or about 0.36 mA at the class A bias point.

Resistor R_4 is selected to provide the 0.36-mA bias current. There should be about 0.36 volt across R_1 with bias current flowing. Since this is a small voltage, we must take into account the 0.8-volt drop at the base-emitter junction of the transistor. Thus the voltage at the base of the transistor must be $0.8 + 0.36$ or 1.16. Resistor R_4 is chosen to provide 1.16 volts across R_4 . This turns out to be about 68,000 ohms.

• 6. To calculate the ac values, redraw the circuit showing all bypassed resistors as shorts to ac and the input impedance of the following stage as resistors (Fig. 7). Note that R_1 and R_2 in parallel form R_{in} which is in parallel with Z_{in} of the emitter follower to form the amplifier input impedance. Since the input impedance of the emitter follower is dependent on the input impedance of the common emitter, we must determine the latter from Fig. 4A. Since $I_b = 0.36$ mA and beta is 50, the input impedance is 3600 ohms. The latter is in parallel with R_4 and R_5 , the bias resistors. The parallel value of R_4 and R_5 is approximately 8800 ohms, which, in parallel with 3600, comes to about 2560 ohms.

The 2560 ohms is paralleled by the emitter follower's own R_3 so the emitter sees about 500 ohms. The emitter follower input impedance becomes 500 times the beta or 25,000 ohms.

The input impedance of the entire amplifier is R_{IN} (3600) in parallel with 25,000 or 3000 ohms, which is what is desired. If the values were found to yield an overall input impedance which was not 3000 ohms, the components would have to be adjusted appropriately.

The voltage gain of the amplifier depends on the gain of the common emitter stage, which, from Fig. 4A, is about 140. Thus the amplifier meets the gain requirement of at least 20.

Capacitor values are chosen so that the response at 100 Hz is -3 dB. So, we lump the impedances associated with a particular capacitor and solve for an equivalent X_C . Since the input impedance is 3000 ohms, $X_{C1} = 3k$ and $C1$ is $0.5 \mu F$ ($X_C = 1/2\pi fC$). Keep in mind that, if you cannot hit this value, a larger capacitance will only lower the response and probably won't be undesirable.

Bypass capacitor $C4$ is associated with a 1000-ohm resistor and its value will be close to $2 \mu F$. Capacitor $C3$ and the 10,000-ohm output impedance combine for a value of $0.2 \mu F$; and the reactance of $C2$ must be 500 ohms so its value is about $3 \mu F$.

Insert all of the above figures into the circuit as shown in Fig. 8.

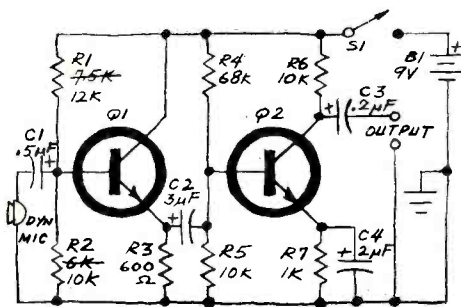

Fig. 8. This is the final circuit layout.

• 7. Breadboard the circuit. When substituting resistor values, keep the same ratio between the values and increase or decrease until you come close to something you have. For instance, assume you do not have a 7500- or 6000-ohm resistor for $R1$ or $R2$. You know the values can go up, so find the ratio of $R1/R2$ —which is 1.25. An increase in both values will merely raise the input impedance, which is not objectionable. Thus, as shown in Fig. 8, $R1$ and $R2$ were changed to 12k and 10k, respectively, since they were readily available.

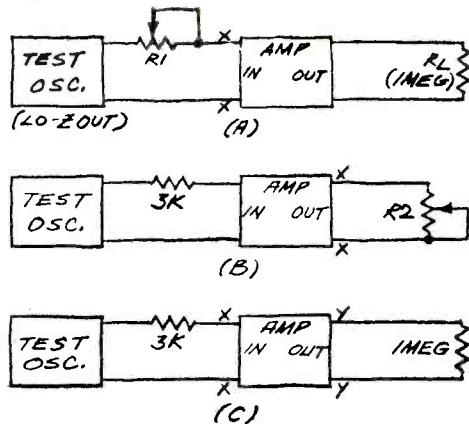

Fig. 9. Testing input/output impedances.

If you want to change the value of $R3$, you will have to go higher, since lowering its value would lower the 3000-ohm input impedance. Keep in mind that, in some applications, the impedance may not be allowed to be different from that calculated.

Now we can build the circuit, apply power and check the voltage levels at the emitters of both transistors. This tells us whether the bias values are correct. It also tells us whether or not the circuit will operate. Then we connect it to the other devices (mike and power amplifier) to see if the whole thing works.

• 8. You may not wish to perform this last step, but if you have an audio generator, use the hookups shown in Fig. 9 to measure the important parameters of the circuit. Figure 9A is used to measure input impedance. Adjust $R1$ until the voltage at the input is half its maximum value. (The value of $R1$ should be greater than the estimated input impedance of the amplifier.) Then remove $R1$ and measure its rotor-to-end resistance.

This value will be approximately the same as the input impedance of the amplifier.

The output impedance is measured in the same way by adjusting $R2$ in Fig. 9B. The voltage gain is found by using the circuit in Fig. 9C and dividing the output by the input. Frequency response is found by adjusting the frequency until two points are obtained at which the output is 0.707 times the maximum. These are the upper and lower 3-dB power-loss points.

Now the design is complete. The checks should show any values that need adjusting. Parts can now be purchased, printed circuit boards can be etched, etc., etc. ♦

Switching Logic Quiz

BY ROBERT P. BALIN

Switching circuits do only what they are logically designed to do. Understanding this logic is very important in designing electronic circuits. In the switching circuits below, the lamp symbols may represent lamps or some other device or decision. Switches which simply apply and remove power in a practical circuit are not shown. Match the statements (1-10) to the circuits (A-J).

1. Scientists must be in complete agreement before they can fire a missile. **E**
2. A code is used to indicate whether the front, rear, or both doors are open. **I**
3. When the darkroom light is on, the warning light outside is off, and vice versa. **B**
4. Either one or both of the operators can start

the motor. **G**

5. Since the pilot might get excited and push the wrong button, they are wired so that, regardless of which is pushed first, the canopy is blown off, and the second ejects him from the plane. **C**

6. Only the fastest gun can hit his target.

7. The decision will be made by a simple majority of the voters.

8. You can turn on the light before you climb the stairs and extinguish it from the top.

9. Let me know if an odd number of those present want to go ahead.

10. We want an indicator lamp to light when the amplifier is on. **D**

(Answers on page 95)

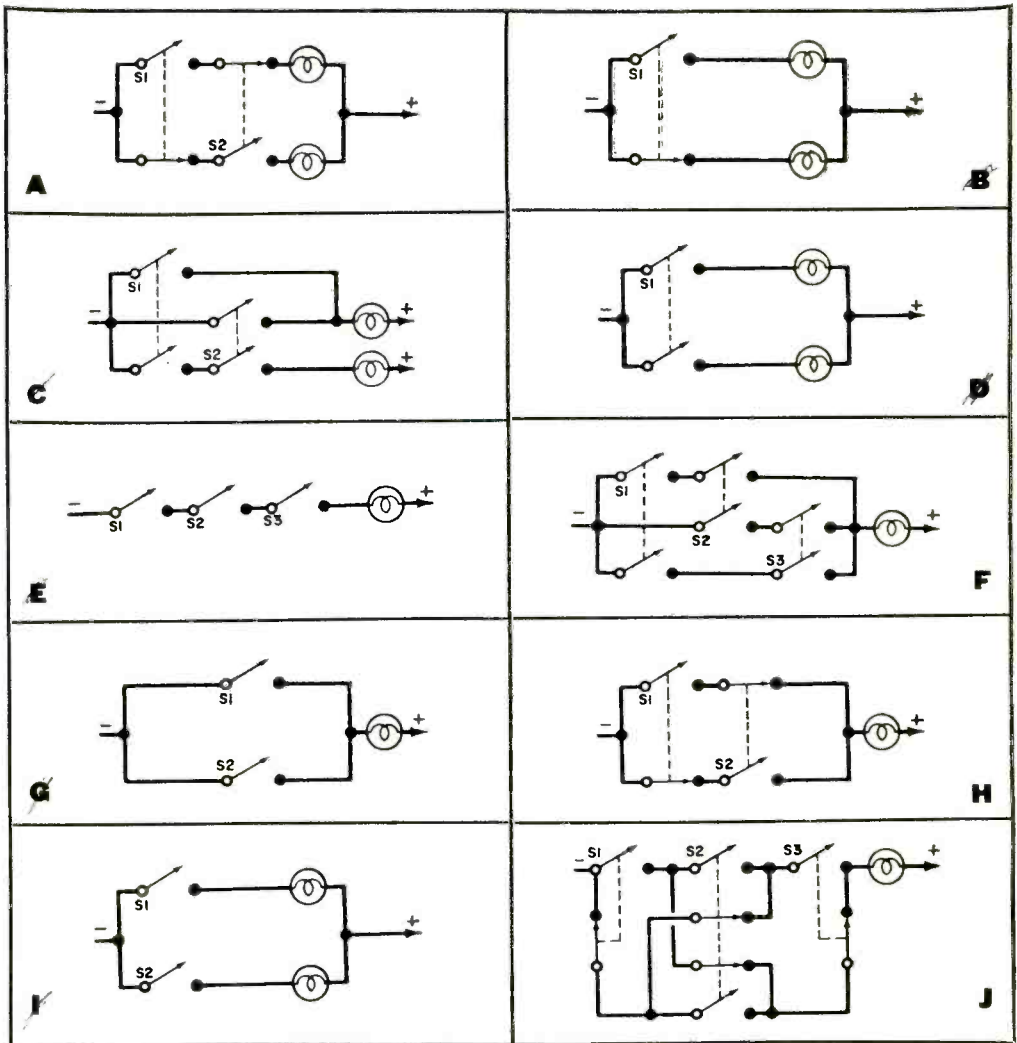

What Makes the TRANSISTOR Tick?

UNDERSTAND TRANSISTORS WITHOUT MATH

BY ROBERT B. WOOD

THE TRANSISTOR is, without a doubt, the most important component known to modern electronics technology. It can be found, in discrete form or as one of many transistors in integrated circuits, in every electronic device that typifies our modern technology. The sophistication of electronic computers, communications and telemetry systems, electronic diagnosis equipment in medicine, and many consumer items can be traced directly to the transistor.

But as complicated in use as the transistor appears to be, understanding its physical makeup and how it operates is really simple. What frightens most beginners to the study of solid-state devices is the high technical and mathematical levels most tutorial works employ in explaining the devices. Many times, a better understanding of transistor theory can be obtained from a non-mathematical treatment—a device employed in the following pages.

Germanium and silicon are the basic crystal materials from which all transistors are made. Because they have most of the properties of metals, which conduct electricity from one point to another in the conductor,

but under ordinary circumstances are non-conductive in the manner of insulators, germanium and silicon are borderline substances. They are, consequently, neither conductors nor insulators according to the common definitions.

In nature, an atom containing four electrons in its outermost electron ring is a stable, or electrically inert, structure. Since electrons are the primary current carriers in the conduction of electricity, it is easy to see that any atom with a full outer electron ring is, by definition, an insulator, incapable of giving up an electron to serve in the current carrying process.

In their pure states, germanium (Ge) and silicon (Si) crystals are electrically inert and behave in the manner of an insulator. However, Ge and Si can be transformed into current carriers simply by adding minute amounts of impurities to the pure crystalline substances through a process known as "doping." The addition of impurities does not by any means transform Ge and Si into good conductors in the manner of metals such as silver and copper. Instead, the doped crystals behave like a poor conductor, conducting only small

amounts of current. Hence, they have come to be termed *semiconductors*.

To understand why a semiconductor does not perform in the traditional manner of a conductor, it is best to compare it to copper, the second-best conductor available. Each copper atom has only one electron in its outer ring. This electron is loosely bound to the nucleus of the atom and, under electrical influence, is relatively free to wander as a conductor of current. In Ge, on the other hand, due to the privileged electron of the impurity, there may be only one so-called "free" electron per million atoms.

Now, when a copper conductor is subjected to electrical influence, electron swarms are free to circulate. This is not true when a doped Ge or Si crystal is subjected to the electrical influence. Although the free electrons do circulate, there are no dense swarms of them since they are very few and far between.

The type of impurity added to the pure Ge and Si crystal determines whether the semiconductor will be n- or p-type. Although the following analysis will focus attention on Ge, it should be understood that the discussion applies equally well to Si.

To make n-type Ge, which has electrons as the principal current carriers, a small amount of arsenic or phosphorous (to mention just two elements currently in use) is scattered throughout the crystal. Each of these impurities has five electrons in its outermost electron ring. Now, if only four electrons are required for a stable electron configuration, arsenic and phosphorous have one extra electron apiece left over for current-carrying purposes.

The p-type Ge, on the other hand, has impurities such as boron, aluminum, or indium added. In the uncharged state, each of the impurity elements has only three electrons in its outermost ring. So, to attain stability, it must "borrow" an electron from a neighboring Ge atom.

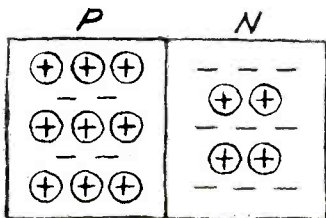

Fig. 1. Typical pn junction representation.

Once the Ge atom gives up an electron, it has one more proton in the nucleus than there are electrons in the electron rings. Hence, it becomes a positive charge known as a "hole." The word "hole" derives from the fact that there is a vacancy in the Ge atom into which electrons can fall.

From our discussion thus far, it is easy to see that in p-type Ge, holes are the principal current carriers. (Although in reality it is the electron that carries the current; but the holes appear to do the moving.) In the n-type Ge, electrons are the principal current carriers.

The simplest semiconductor device, the diode, can be represented by the diagram in Fig. 1. The diode consists of a sandwich of n- and p-type material. Where the two

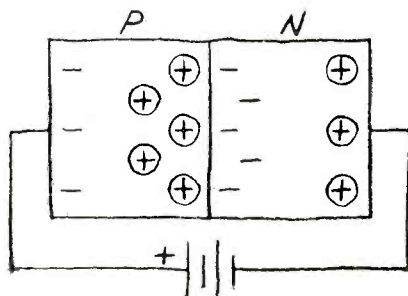

Fig. 2. Pn junction is shown forward-biased.

types of material touch, we have a junction which is responsible for providing both transistor and diode action.

The hole carriers, which are circled plus signs, predominate in the p-type material. The electron carriers, which are represented by minus signs, predominate in the n-type material. Note that in both types of material, the current carriers are in a pronounced minority.

With no voltage applied to the diode, no voltage difference exists between the two types of material and the current carriers stay put. Now, connect a battery across the diode as shown in Fig. 2, and observe what happens.

The positive pole of the battery repels the holes and attracts the electrons in the p-type material. Likewise, the negative pole of the battery repels the electrons and attracts the holes. The repelled charges move toward the junction where some of the holes and electrons combine and become neutral Ge atoms. For every atom thus "neutralized,"



Fig. 3. Supermarket checkout counter can be used to explain "hole" flow in transistor.

an atom in the p-type material loses an electron to the positive pole of the battery and thus begins its migration toward the junction.

With the battery connected to the diode as shown, the semiconductor is forward biased. In this condition, the continuous hole replacement and drift toward the junction process makes up the current flow. The process will continue until the battery is disconnected or it runs down.

As mentioned earlier, holes are only apparent current carriers. It is the electron that still carries the current through the semiconductor material to provide current flow. During the interchange, no atom of Ge leaves its place in the crystal.

To simplify the process of hole movement, let us make an analogy to a supermarket checkout station. In Fig. 3, we see four customers at the checkout counter. One customer has already checked and vacated the position in front of the cashier, thus creating a hole. The next customer moves up to the counter, in turn, creating a hole behind him, and so on down the line until all four customers have moved up one position. The checkout counter remains where it is, just as the Ge atom remains put in the semiconductor. Only the customers have moved, just as only the electrons in the semi-

conductor move. The vacated space made by each customer as he moves up only *appears* to have moved, just as the holes in the semiconductor appear to move.

With the hole movement problem cleared up, let us reverse the polarity of the battery to obtain the setup shown in Fig. 4. Here, the holes attracted by the negative post of the battery move away from the junction in the p-type material, and the electrons attracted by the positive post of the battery move away from the junction in the n-type material. No current flows, and the semiconductor is said to be back, or reverse, biased, allowing a minute amount of current to flow in the reverse direction. If an alternating voltage were applied to the junction instead of dc, the current would flow each time the junction is forward biased and cease when the junction is reverse biased.

In a vacuum tube rectifier, half of the ac cycle is neatly and cleanly eliminated because of the large distance between the anode and cathode of the tube—compared with the contact made between the n and p parts of a semiconductor diode. In the latter, the minute reverse current flow resulting from the privileged carriers does not allow complete rectification. A small portion of the unwanted half cycle gets through, but it does not hamper effective rectification and, in most cases, can be disregarded.

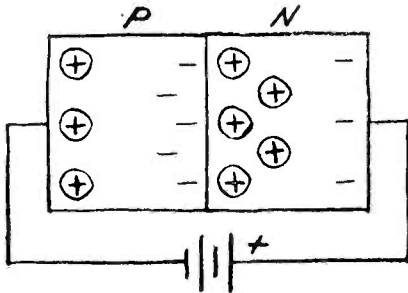

Fig. 4. Junction is shown in reverse bias.

The transistor can be viewed as two diodes connected back-to-back as illustrated at the upper left in Fig. 5. Each diode consists of a block of n-type and a block of p-type material (remaining drawing at top of Fig. 5). In the transistor, the center block is shared by each of the outer blocks in turn to make up the diodes.

There are two basic types of transistors. One is an npn with a block of p-type material sandwiched between two blocks of n-type material; the other is a pnp, with

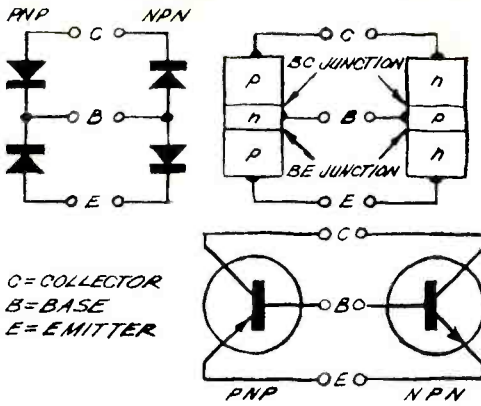

Fig. 5. Three methods of drawing transistor.

two blocks of p-type material separated by a block of n-type material. Schematic symbols for each type are shown at the bottom of Fig. 5. Note that in the schematic representations the arrow on the emitter always points toward the n-type material (direction of hole flow)—toward the base in the pnp transistor and away from the base, or the emitter itself, in the npn transistor.

The center block in the transistor is known as the base, while the outer two blocks are the emitter and collector. In the practical transistor, the base is much thinner than are the emitter and collector blocks. This is done to aid in the amplifying ability of the transistor.

In Fig. 6, we see both types of transistors connected in amplifier configurations. In both cases, the base-emitter junction is forward biased in the direction of easy current flow, while the base-collector junction is reverse biased to oppose the free flow of current. Hence, the emitter and collector are said to be connected series-aiding, with control of the majority carriers from the former to the latter directly dependent on the base drive.

Bear in mind that the transistor is a *current* amplifier. This means that a base drive

signal in the form of a voltage must first be converted to a current by passing it through base resistor R_B . Once converted to a current and applied to the base, it allows current to flow across the base-emitter junction. The current traversing the junction is limited by the value of R_B and the level of the potential supplied by input drive battery B_1 . As long as current circulates through the base-emitter junction, there will be current flow through both junctions.

The collector current, resulting from the flow of majority carriers from the emitter through the base, is many times larger and directly proportional to the base current that initiates it. Because the base region is narrow, most of the carriers moving through the emitter and into the base are propelled into the collector. In practical transistors, 92-99 percent of the carriers from the emitter reach the collector. Hence, almost all of the current from the emitter flows through the collector (on the order of hundreds of milliamperes), while it is controlled by a very small base current (usually on the order of only tens or hundreds of microamperes). That's amplification!

The amount of current that flows through the collector is controlled by the degree to which the base is biased by B_1 (our base-drive signal), the collector potential supplied by B_2 , and the load resistor R_L . If we fix the value of R_L and the voltage of B_2 and substitute a variable-voltage input signal for B_1 , we can easily vary the output from zero to maximum. Hence, it is possible to use the amplifier for audio and r-f purposes.

The output signal from the amplifier is in the form of a voltage. As the current passes through the transistor and R_L it causes a voltage drop across each. The voltage drop across the transistor, from emitter to collector, is the output signal. It is necessary for R_L to be in the circuit so that a voltage drop can be developed across the transistor. ♦

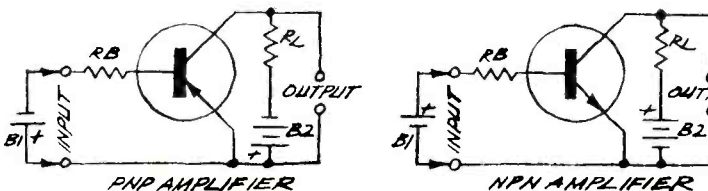

Fig. 6. Biasing arrangement for npn transistor is same as for pnp, except battery polarities.



A Practical Expanded Scale Milliohmmeter

MEASURING THE ALMOST UNMEASURABLE

This test instrument was developed to measure what most electronic experimenters are inclined to think of as inconsequential resistances. However, the less-than-1-ohm losses are important factors in detecting hi-fi ground loops, poor contacts in high amperage circuits, corrosion, etc. The circuit is a simple, easily balanced bridge. Provision is made in the instrument for long storage and battery protection.

CONVENTIONAL home and field-type VOM's are not designed to resolve accurately resistance readings between zero and one ohm. Even the very best multimeters employ a logarithmic scale, with 10 ohms as an average center-scale reading when the range switch is in the times-one position. And you need a very sharp eye, indeed, to differentiate between readings of, say, 0.27 and 0.05 ohm on a multitap transformer.

Commercially available milliohmmeters

BY DAVID R. CORBIN

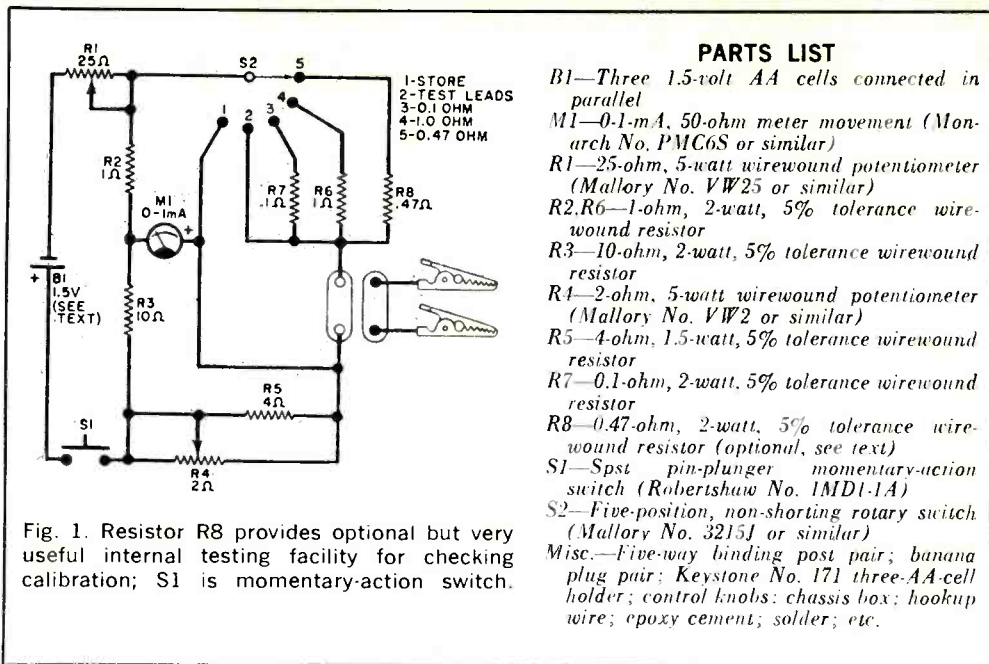

Fig. 1. Resistor R8 provides optional but very useful internal testing facility for checking calibration; S1 is momentary-action switch.

PARTS LIST

- B1—Three 1.5-volt AA cells connected in parallel
- M1—0-1-mA, 50-ohm meter movement (Monarch No. PMC6S or similar)
- R1—25-ohm, 5-watt wirewound potentiometer (Mallory No. VW25 or similar)
- R2, R6—1-ohm, 2-watt, 5% tolerance wirewound resistor
- R3—10-ohm, 2-watt, 5% tolerance wirewound resistor
- R4—2-ohm, 5-watt wirewound potentiometer (Mallory No. VW2 or similar)
- R5—4-ohm, 1.5-watt, 5% tolerance wirewound resistor
- R7—0.1-ohm, 2-watt, 5% tolerance wirewound resistor
- R8—0.47-ohm, 2-watt, 5% tolerance wirewound resistor (optional, see text)
- S1—Spst pin-plunger momentary-action switch (Robertshaw No. 1MD1-1A)
- S2—Five-position, non-shorting rotary switch (Mallory No. 3215J or similar)
- Misc.—Five-way binding post pair; banana plug pair; Keystone No. 171 three-AA-cell holder; control knobs; chassis box; hookup wire; epoxy cement; solder; etc.

are expensive instruments, costing \$175 and more. However, with modern solid-state equipment in which biasing resistors in the 0-1-ohm range are common, a milliohm-meter is almost a must for measuring such values. By eliminating unnecessary ranges and maintaining accuracy to within practical limits, it is possible to build a milliohmmeter for less than \$20.

The milliohmmeter described in this article has two very useful ranges—0-1 ohm and 0-0.1 ohm. The scale is very nearly linear (it would take very expensive and elaborate equipment to show that it is not), but is actually a tiny portion of a logarithmic curve, expanded to cover the full swing of the meter pointer.

Theory of Circuit Design. As shown in Fig. 1, the circuit of the milliohmmeter consists of a resistive bridge, one side of which is made up of the test leads (and resistance being measured). Closing S1 causes current to flow from B1 via R1 to the bridge.

With S2 in position 2 and the test leads shorted together, R4 is adjusted to ten times the lead resistance, balancing the 1:10 ratio of the R2-R3 side of the bridge. The meter will now indicate zero, regardless of the setting of R1. If the test leads are disconnected, with S1 closed, the bridge will be heavily unbalanced in a direction such that current

will flow from R2 through the meter to R4, swinging the meter pointer off-scale.

For calibration purposes, S2 must be switched to R6 for the 1-ohm range or R7 for the 0.1-ohm range. If S2 is in position 3, R7 is placed in series with test leads, unbalancing the bridge circuit and moving the meter pointer by an amount determined by calibration potentiometer R1. Potentiometer R1 is then adjusted to produce a full-scale pointer deflection.

Setting S2 to position 2 and placing a 0.1-ohm resistor across the leads will also cause a full-scale deflection of the meter pointer (assuming that the setting of R1 remains undisturbed). Hence, it is possible to compare the standard internal resistances of R6 and R7 with the values of resistance being measured and obtain direct readings in ohms.

Resistor R5 is used to smooth the operation of R4 and help balance the bridge. An optional feature of the circuit is R8 which provides a useful internal resistance for checking calibration.

Construction. Assembling the milliohmmeter should present no problems, since there is nothing critical about the circuit. As shown in Fig. 2, all components, except the battery bank and its holder, mount directly to the front panel. To simplify

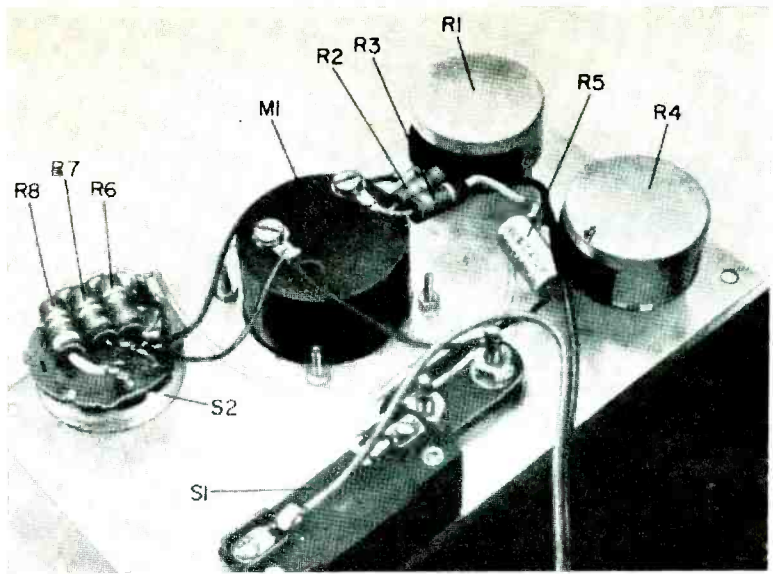
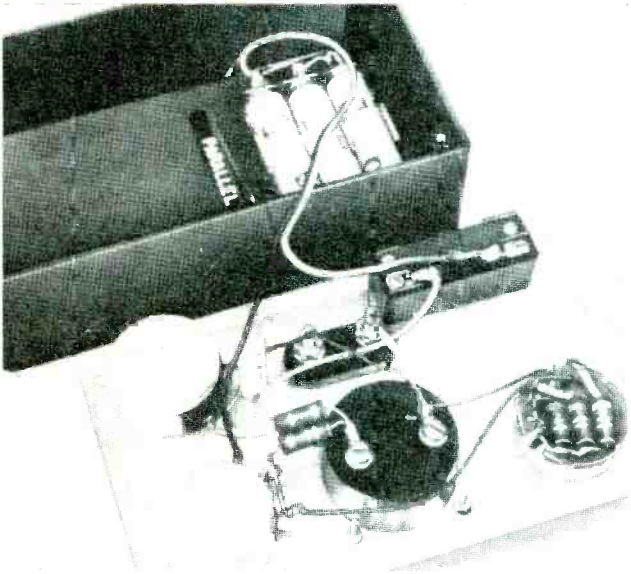

Fig. 2. The simplicity of the circuit allows all components to connect directly to the control and meter lugs.



The battery supply for the circuit is mounted in place with the aid of three AA-cell holders and machine hardware.

mounting, a hard-set epoxy cement bonding is used between the top of the housing of switch *S1* and front panel and between the battery holder bank and case. The meter movement, binding posts, function switch (*S2*), and potentiometers fasten in place with the hardware supplied.

Since there are only a few components, wiring by the point-to-point method is easy. Note, however, that the bank of three batteries that make up *B1* must be connected in *parallel* with each other. Also, when mounting the binding posts, make absolutely cer-

tain both are insulated from the front panel.

Once the circuit is wired up as illustrated in Fig. 2, assemble the case. Now, make your test leads. Probe-type leads are useless for the milliohmmeter. What are needed for the test ends of the cables are strong spring-loaded clips that will lock solidly onto the leads of the components under test. This is necessary because in dealing with resistance measurements in the fraction of an ohm range, contact resistance becomes an important factor in accurate calibration and test readings.

PRINTED CIRCUITS

FAST — EASY
with DATAK's

DIRECT ETCH SET

EASY—patterns rub down directly on the copper board and connect with rub-down lines or tapes supplied.

FAST—safe new etchants will etch a 2 oz. copper board in 30 minutes.

ACCURATE— $\pm .002$ " print tolerance so parts and connectors mate with no errors.



Circuit Made With ER-1

COMPLETE ER-1 SET contains hundreds of dry transfer DIP, flatpack, TO-5, IC, and transistor patterns; $\frac{1}{16}$ " and $\frac{1}{32}$ " etch resist tapes; 4 copper clad boards; $\frac{1}{4}$ lb. dry etch; tray and instructions. \$5.95 ppd.

IN STOCK AT ALLIED AND OTHER DISTRIBUTORS
WRITE FOR FREE CATALOG listing this and many other dry transfer marking sets.

The DATAK Corporation

65 Seventy-first Street • Guttenberg, New Jersey 07093
CIRCLE NO. 2 ON READER SERVICE CARD

SOLDERING + DESOLDERING + RESOLDERING = SOLDERABILITY

ELEMENTARY TO ELITE
WORLD'S MOST PRACTICAL SOLDER HANDLING TOOLS

meets industries demands.....

with a COMPLETELY PORTABLE SOLDERING/DESOLDERING/RESOLDERING SYSTEM

EDSYN
1505B ARMINIA STREET
VAN NUYS, CALIFORNIA 91406
PHONE (213) 989-2324
TELEX NO. 85-1489 EDSYNLX VAN

NEW FANOVISION
144 Page Manual
SolderABILITY TECHNIQUES

* NOTE: FANOVISION Manual will be sent FREE with purchase of \$7.95 (or more) of any EDSYN Products. Limit one FREE MANUAL to a customer.

CIRCLE NO. 7 ON READER SERVICE CARD

It is not necessary to use any special type of test lead cable, nor are the lengths of the cables critical. The instrument is designed so that, in zero-adjust nulling and full-scale deflection calibration, the test lead becomes part of the bridge circuit and are "nulled out" regardless of their specific resistances. (It may seem strange that you have to consider test lead resistance, but the meter will easily demonstrate that if a null is obtained using only one lead, the meter will indicate half-scale deflection with both leads—and after calibration will give the resistance in milliohms of the lead not used in the nulling procedure!)

How To Use. First, short together the alligator clips on the test leads. It is best to clip the leads together in the same manner as they would be clipped to the leads of the component under test. This will assure good contact resistance. If you merely hold the clips together with one hand, you will find adjustments difficult to make because of the varying pressure you exert on the clips. Especially noticeable on the 0.1-ohm range will be the "jumpy" movement of the meter pointer.

Next, set *R1* to maximum resistance and *S2* to the TEST LEADS position. Depress *S1* and adjust null control *R4* for a zero meter reading. Then release *S1* and set *S2* to the desired range position. Again, depress *S1*. Now, adjust the setting of calibration control *R1* for a full-scale pointer deflection.

Release *S1*. Set *S2* to the TEST LEADS position. Your meter is now ready to measure resistance values in the range for which it was calibrated.

When storing the milliohmmeter, set *S2* to the STORE position. This reduces the chance of damage or off-scale readings should the PRESS-TO-TEST switch be accidentally depressed. As with any type of electronic equipment, batteries should be removed altogether for prolonged storage.

Aside from checking the values of less-than-one-ohm resistors, the milliohmmeter is a handy item to have available for other tests. It can be used to check corrosion in automotive wiring connections, a serious source of IR losses even if only a few milliohms of resistance is involved. Other uses include troubleshooting motors, generators, and starters, measuring the cold resistance of incandescent light bulbs, winding bias and motor control resistors from hookup wire, and checking for resistance in power distribution systems and ground circuits. ♦

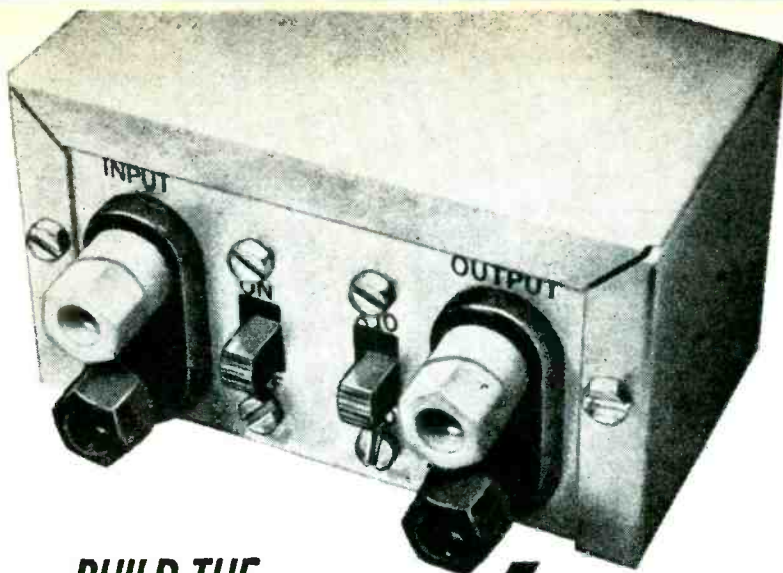

BUILD THE
X10 / X100
INSTRUMENT SENSITIVITY BOOSTER

EXTEND THE RANGE OF YOUR SCOPE OR VTVM

BY JAMES BONGIORNO

MOST low- and medium-priced oscilloscopes have input sensitivities between 10 and 15 millivolts per scale division. This means that, if you are probing for very low-level signals (such as 100 to 200 microvolts of noise in a preamp), even a wide-open gain control on the scope may not help.

Of course, you can always build a one-transistor preamplifier which simply boosts the scope's input sensitivity, but you may run into more problems than you solve. The bandpass of an amplifier for this purpose must be at least as good as that of the scope. The amplifier should not introduce any noise of its own; it must not clip the signal; and it should have good rise and fall times, very low harmonic distortion, and a high enough input impedance to avoid loading the circuit under test. Obtaining

these qualifications in a better preamplifier is not impossible. What you need is the X10 /X100 Instrument Sensitivity Booster.

The specifications in the Table show just how good the Booster is; and a glance at the circuit in Fig. 1 will prove that this is not just an everyday preamp but a carefully designed, highly useful instrument "add on."

The Booster can also be used to extend the range of old VTVM's that do not have the very low voltage scales required for semiconductor voltage measurements.

Construction. It is best to build the Booster on a printed circuit board, using the full pattern and component layout shown in Fig. 2. Since the board is small and spacing is close, take care not to make

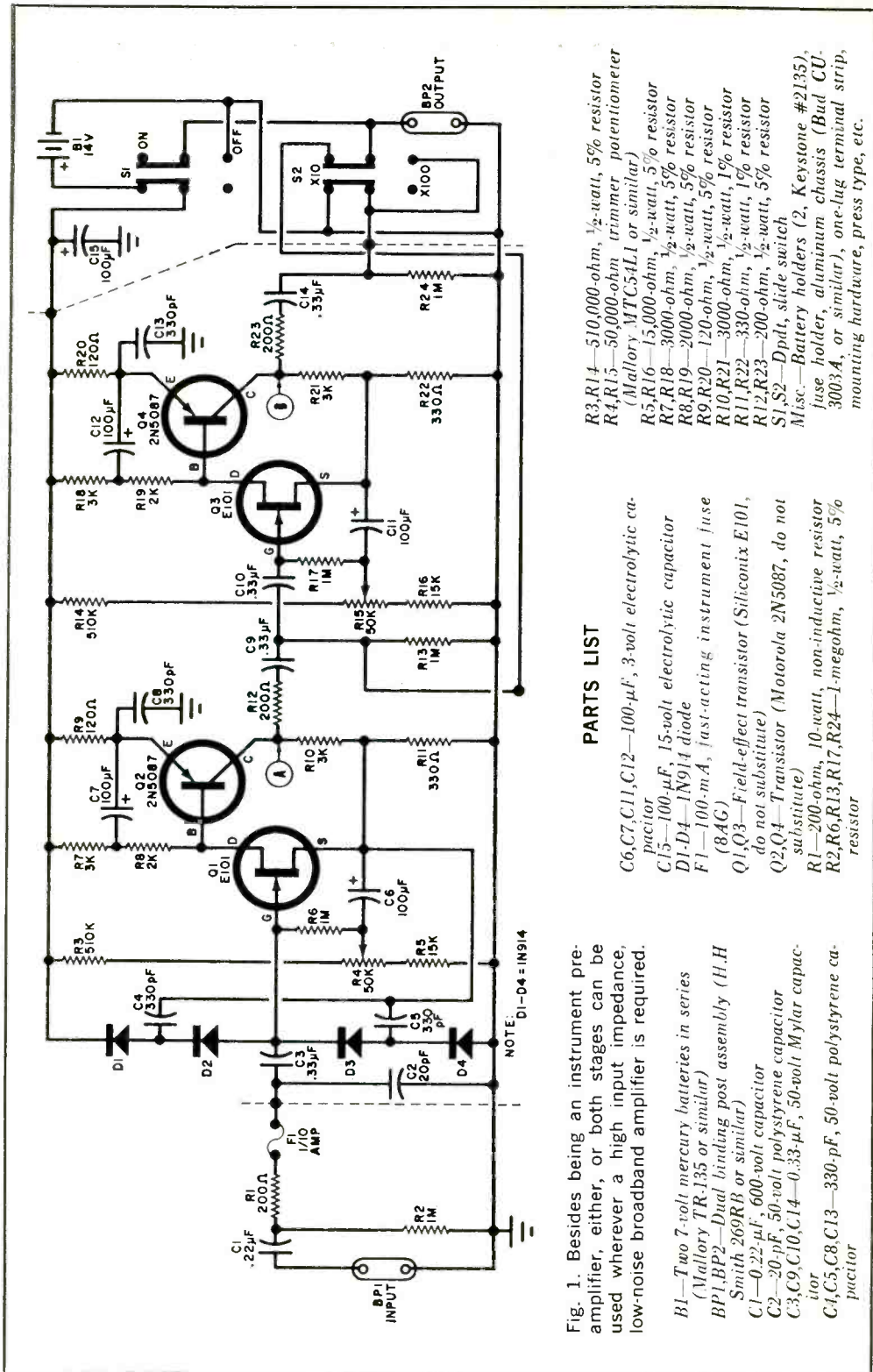

Fig. 1. Besides being an instrument pre-amplifier, either, or both stages can be used wherever a high input impedance, low-noise broadband amplifier is required.

- B1—Two 7-volt mercury batteries in series (Mallory TR-135 or similar)
 BP1, BP2—Dual binding post assembly (H.H. Smith 269RB or similar)
 C1—0.22- μ F, 50-volt polystyrene capacitor
 C2—20-pF, 50-volt polystyrene capacitor
 C3, C9, C10, C14—0.33- μ F, 50-volt Mylar capacitor
 C4, C5, C8, C13—330-pF, 50-volt polystyrene capacitor

PARTS LIST

- C6, C7, C11, C12—100- μ F, 3-volt electrolytic capacitor
 C15—100- μ F, 15-volt electrolytic capacitor
 DI-D4—IN914 diode
 F1—100-mA, fast-acting instrument fuse (84C)
 Q1, Q3—Field-effect transistor (Siliconix E101, do not substitute)
 Q2, Q4—Transistor (Motorola 2N5087, do not substitute)
 R1—200-ohm, 10-watt, non-inductive resistor
 R2, R6, R13, R17, R24—1-megohm, 1/2-watt, 5% resistor

- R3, R14—510,000-ohm, 1/2-watt, 5% resistor
 R4, R15—50,000-ohm trimmer potentiometer (Mallory MTC54L1 or similar)
 R5, R16—15,000-ohm, 1/2-watt, 5% resistor
 R7, R18—3000-ohm, 1/2-watt, 5% resistor
 R8, R19—2000-ohm, 1/2-watt, 5% resistor
 R9, R20—120-ohm, 1/2-watt, 5% resistor
 R10, R21—3000-ohm, 1/2-watt, 1% resistor
 R11, R22—330-ohm, 1/2-watt, 1% resistor
 R12, R23—200-ohm, 1/2-watt, 5% resistor
 S1, S2—Dpdt, slide switch
 Misc.—Batteries holders (2, Keystone #2135), fuse holder, aluminum chassis (Bud CU-3003A, or similar), one-lug terminal strip, mounting hardware, press type, etc.

NOTE: DI-D4 = IN914

solder bridges between adjacent foil lines. Also note that, if you duplicate the prototype shown here, $R4$ and $R15$ are mounted on the foil side of the board. They can be mounted on the component side if you prefer another mechanical arrangement.

A $4" \times 2\frac{1}{4}" \times 2\frac{1}{4}"$ aluminum two-piece chassis can be used to hold the PC board plus the batteries, switches, and input-output connectors. As shown in the photographs, the battery clips are mounted on the bottom of the U-shaped chassis with 2-inch PC board mounting screws between the clips and $3\frac{1}{4}"$ apart. The dual binding posts, one for the input and the other for the output, and the two switches are mounted on one long side.

After securing the two PC board mount-

ing screws, place a nut on the screw nearest the input jacks and about 1" above the chassis bottom. Place a one-lug terminal strip (ungrounded) on the screw, and secure it in place with a lockwasher and nut. With the batteries in place in their clips, place $C1$ in position on top of the batteries and solder one end to the "hot" input connection (BPI) and the other end to the one-lug terminal strip along with one end each of $R1$ and $R2$. The other end of $R2$ is soldered to the ground battery clip connector along with the negative end of $C15$. The other end of $R1$ is connected, through fuse $F1$, to the input terminal of the PC board.

Before permanently securing the board in place, temporarily short capacitor $C2$

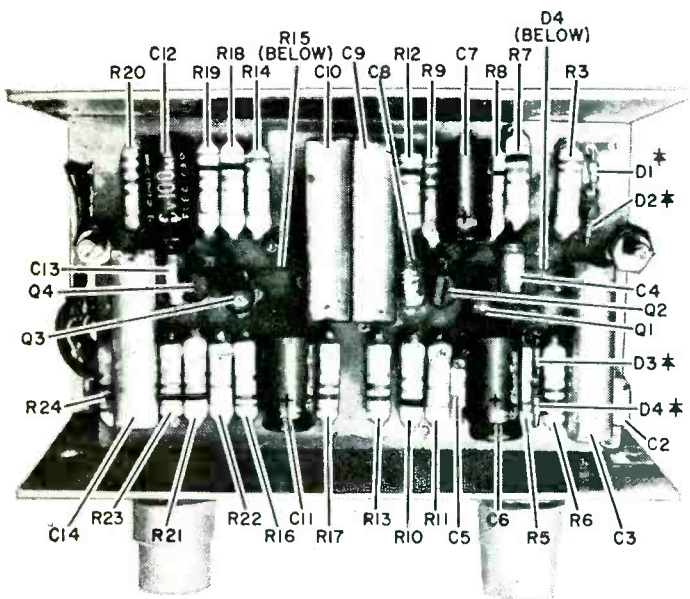
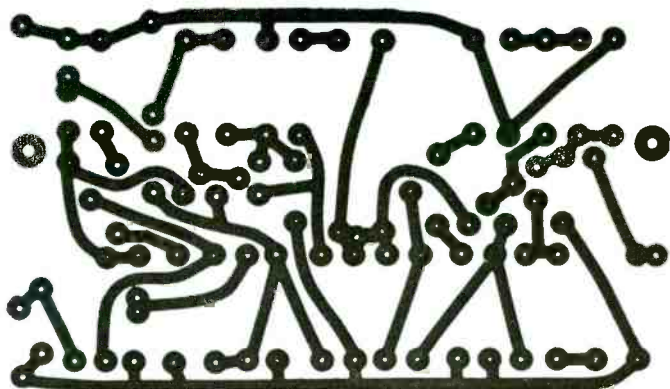
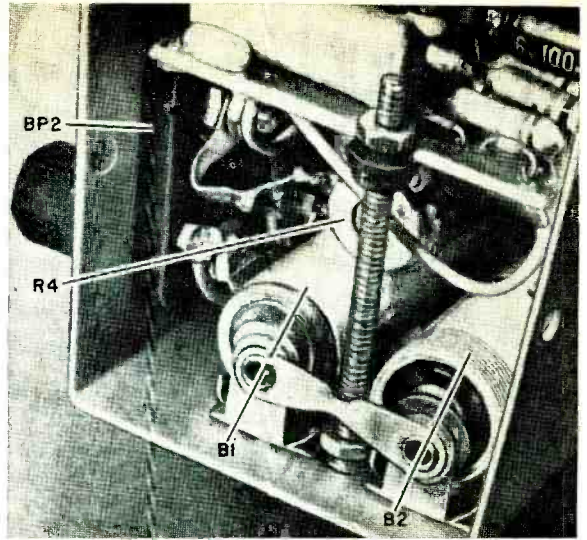

Fig. 2. The actual size printed-circuit foil pattern (right) can be used to make a compact arrangement. Components are installed as shown above. Booster may be installed in the actual instrument if a suitable power source can be made available.



The circuit board is mounted on a pair of long screws using nuts and washers to keep the board in place. The batteries mount in clips secured to the base of the chassis. Note that in the original prototype, both potentiometers are located on the under (foil) side of board.



and resistor *R13* to ground. Connect the battery power, and wait a few seconds for the voltage to stabilize. Connect a dc voltmeter between test point A and ground (see Fig. 1) and adjust *R4* until the meter indicates exactly 7.2 volts. Do the same at test point B using *R15* to make the voltage adjustment. Remove the two temporary shorts.

Wire the complete circuit as shown in Fig. 1. Then mount the PC board on the two long screws, using a nut below and above the board to secure it in place. All grounds should be made to the same grounded battery clip where the negative end of *C15* is connected.

Although 1% resistors are specified for the gain-determining elements (*R10*, *R11*,

The off-board components forming the input to the circuit are supported by a terminal strip affixed to a supporting screw. Use one point as common ground.

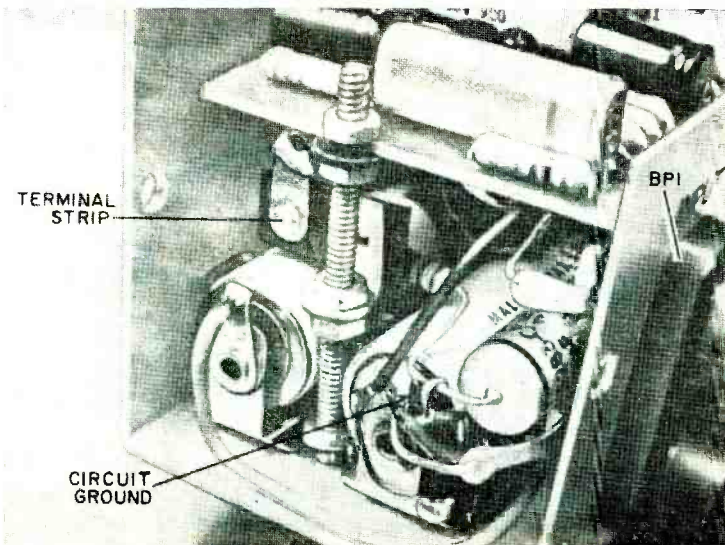

R21, and R22), they may be trimmed if desired to obtain more exact multiplication ratios. Do not substitute for Q1 and Q3 as this particular FET has exactly the characteristics required for best operation of the circuit.

Operation. Since the overall noise at the input is less than 7 microvolts, the Booster can be used to trace very low-level signals; and it can be used at frequencies up to 10 MHz. If you use a scope having an input capacitance of less than 10 pF, measurements to 10.7 MHz (FM i.f.) may be obtained by using a suitable probe. Sensitivity is high enough in the X100 range to view a signal as low as 70 microvolts with a 20-dB noise margin.

Since the rise time is fast (50 nanoseconds or less), the Booster can be used with all types of electronic systems. However, remember that it is an unterminated preamplifier and should be used with a high-input-impedance scope.

HOW IT WORKS

The Booster contains two similar stages of amplification, each having a gain of 10 (20 dB). Two stages were used to get the high gain as well as extend the frequency response. If only one stage were used, there would be less feedback and the frequency range would be to only 700 kHz rather than 7 MHz.

The inputs to both stages use a FET with naturally high input impedance and are connected in the bootstrap mode to further increase the input impedance. The FET also has a lower noise level than a bipolar transistor, especially when the source impedance is high. The actual frequency response is determined by the two bipolar transistors in the circuit.

Resistor R1, fuse F1, diodes D1-D4, and capacitors C4, C5, and C15 form the ac input protection circuit. Any positive input voltage that exceeds the 14-volt battery level causes D1 and D2 to be forward biased. As the voltage increases so does the voltage drop across R1 (current also increases). Capacitor C15 bypasses this ac current to ground to protect the battery. When the current reaches about 200 mA (depending on the amount of overvoltage and the time constant), the fuse blows.

On the negative excursions, any voltage more negative than about 2 volts, forward biases D3 and D4, shunting the signal to ground. Capacitors C4 and C5 bootstrap the protection diodes at high frequencies so that their capacitance does not shunt the input impedance.

TECHNICAL SPECIFICATIONS

Gain: X10 or X100, optional switching
Frequency response: 3.5 Hz to 7 MHz (-3 dB)
Maximum output level (before clipping): 3.5 volts rms
Input impedance: 1 megohm in parallel with less than 10 pF
Equivalent wideband input noise: less than 7 microvolts, input shorted
Rise time (unloaded): 50 nanoseconds or less
Fall time (unloaded): 70 nanoseconds or less
Harmonic distortion up to 20 kHz (X10 position):
 less than 0.5% at 3 volts rms output;
 less than 0.15% at 1 volt rms output;
 less than 0.05% at 0.3 volt rms output
Maximum dc input: 600 volts
Maximum input level: total dc and peak ac should not exceed 600 volts.

The connections to the input and output of the preamplifier must be made carefully to avoid degradation of the signal. The best method is to use short pieces of wire to make all connections to the scope. Do not use coaxial cables as the preamp will not drive coax properly at high frequencies.

Dc input protection is provided by C1 which should have a rating of 600 volts dc or more. Remember, however, that the total input voltage should not exceed 600 volts—the dc level plus the peak ac signal. ♦

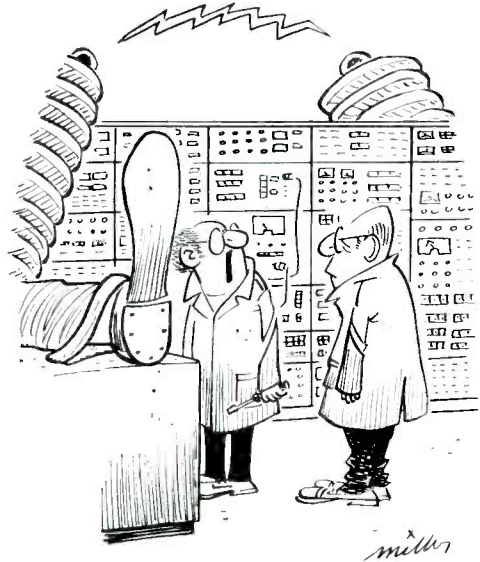

"So why should the experimenter have to start from scratch when we can give it to him in kit form?"

Build a RECHARGEABLE FLASHLIGHT

CONVERT YOUR BATTERY-EATING FLASHLIGHT
TO A MODERN RECHARGEABLE

BY JOHN McNARNEY

NOW that you can get low-cost, rechargeable nickel-cadmium batteries (1.25 volts), why not take advantage of them and build a flashlight that can be recharged from either the 117-volt ac power line or a 12-volt vehicle supply? The recharging circuit shown here provides either fast, slow (overnight), or trickle charge.

Provision is made for two power inputs: *J1* for ac and *J2* for dc. In ac charging, connector *P1* is connected to *J1*. In this case, be sure that dc plug *P2* is not connected to *J2*. Transformer *T1* and rectifier diodes *D1* and *D2* provide a dc source of 3 volts. A jumper in *P1* connects the common return line. The charging current applied to the cells is determined by how much of *R1* is in the circuit. When *S2* is in position C, only a few milliamperes flow, providing a trickle charge. In position B, the resistance of *R1* is cut to permit the manufacturer's specified overnight charging current to flow, while position A connects the cells directly to 3 volts. The current flow in the last case is a few hundred milliamperes (must be measured when the circuit is built) and can be used to operate the flashlight from an ac source. The current must not exceed the cell rating. A Buss HKP fuse holder and fuse in the ac line is suggested.

In dc charging, the 12-volt supply is applied to *J2* through *P2*. In this case, the two cells are connected between one end of *R1* and a slide so that 3 volts is present across the cells. Switch *S2* must be in position C for dc charging.

There are two approaches that can be taken to construction. One is to build the entire flashlight in a small enclosed chassis with a flashlight head (lamp and reflector) on one end and *J1* and *J2* installed and identified on the side of the enclosure.

The second approach is to mount a small two-contact jack on an existing flashlight case (that will hold the nickel-cadmium cells instead of the D cells normally used) and connect the two jack terminals to the cells by soldering. Make sure that this jack is keyed so that its associated plug can be installed in only one way—the nickel-

cadmium-cells can be damaged by application of reverse polarity. The rest of the components can then be installed in a small enclosure with a cable connected to the flashlight when recharging.

The only component requiring selection and adjustment is *R1*. This resistor can be between 75 and 100 ohms and should be rated at least 10 watts. One slider should be at the 90% point and is connected to position B to *S2*. The other slider should be set at the point where 3 volts is applied to the cells when the dc connector is in place and 12 volts is applied to the circuit.

Using the manufacturer's specifications, select a value for *R1* that will allow a trickle charge to pass through the cells when *S2* is in position C and the charger is on ac. The dc power supply cable can be fabricated from a 12-volt automotive inspection light cable with a 4-pin connector. ♦

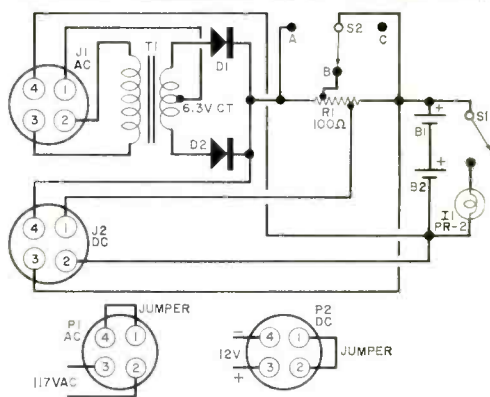

PARTS LIST

- B1, B2*—1.25-volt rechargeable nickel-cadmium cells (Eveready C2T, N56T, Burgess CD7L, Edmund 40,986, or any equivalent that will charge from the available voltage)
- D1, D2*—Silicon rectifier diode
- I1*—2.38-volt flashlight bulb (PR-2)
- J1, J2*—4-pin connector socket
- P1, P2*—4-pin connector plug
- R1*—100-ohm, 10-watt wirewound resistor with two slide contacts
- S1*—Spst slide switch
- S2*—Single-pole, three-position switch
- T1*—6.3-volt CT filament transformer

5 GREAT NEW KITBUILDING PROJECTS FROM HEATH:

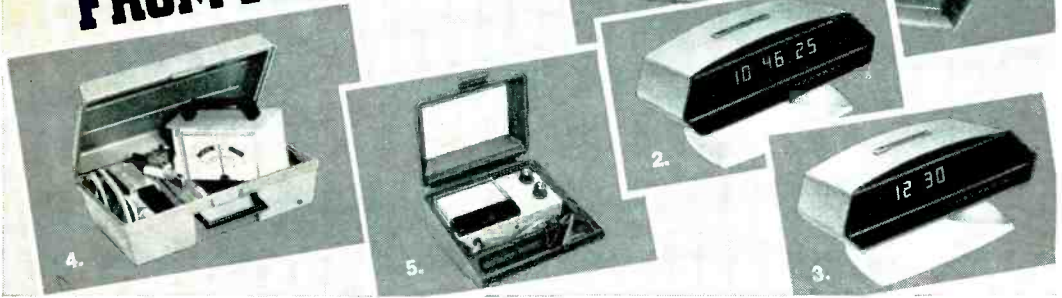

1. Digital technology comes to TV with the new Heathkit GR-2000 Color TV—so advanced it's like nothing you've ever seen before! It has on-screen digital channel numbers and an optional digital clock. A programmable digital counter silently selects channels. Up to 16. No blank channels. Intermix any UHF and VHF, even repeat channels if you wish. The long-life all-electronic pushbutton varactor tuning eliminates noisy mechanical tuners and corroding contacts. The unique new fixed-filter I.F. amplifier never needs instrument alignment—so color pictures retain their brilliance and clarity year after year. Its new 100% solid-state chassis has more integrated circuits than any other TV. Its new 25" (diagonal) matrix picture tube is the most advanced available. The Heathkit GR-2000 Digital Color TV may be the most rewarding kit-building experience of your life. Kit GR-2000, 669.95*, less cabinet.

2. New Heathkit Digital Electronic Alarm Clock. Like no other clock you've ever owned...with features as new as tomorrow! Wakes you with an electronic "beep" and shuts off at a touch—no fumbling for knobs or switches. And if the power goes off, you still get to work on time—the clock has its own emergency battery supply. Other features are a 24-hour alarm cycle with AM indicator light to aid in setting; 7-minute repeatable snooze cycle; 12 or 24-hour time format; automatic brightness control. Kit GC-1092A, 82.95*.

3. New Heathkit Digital Electronic Calendar/Clock. In this unique timepiece, we swapped the alarm feature for the date—and held the same low kit price featured in its alarm clock twin. Reads out the time in hours, minutes & seconds, with big orange digits. Plus, it gives you the month and day, either automatically for 2 seconds out of every 10, or anytime at the touch of an electronically activated control. It also features 12 or 24-hour format, automatic brightness control, and built-in fail-safe reserve battery supply. Kit GC-1092D, 82.95*.

4. New Heathkit Exhaust Gas Analyzer. A timely kit for the week-end mechanic and the professional alike. Checks exhaust gas of cars for pollution level and measures air/fuel mixture to help you tune for top economy. Also a great training aid in automotive mechanics classes for demonstrating results of proper anti-pollution system adjustments. Easy to assemble, simple to use. Kit CI-1080, 59.95*.

5. New Heathkit Tune-up Meter. Successor to the popular Heathkit ID-29—now with new, extended 0-20 VDC range. Checks dwell on 4-cycle-3, 4, 6 & 8 cylinder engines with conventional ignition. Two rpm ranges. Reads voltage from 0-20 VDC. Use on 6 or 12V systems, either ground. No batteries required. Kit CM-1073, 29.95*.

HEATHKIT ELECTRONIC CENTERS —
Units of Schlumberger Products Corporation.
Retail prices slightly higher.

ARIZ.: Phoenix; CALIF.: Anaheim, El Cerrito, Los Angeles, Pomona, Redwood City, San Diego (La Mesa), Woodland Hills; COLO.: Denver; CONN.: Hartford (Avon); FLA.: Miami (Hialeah), Tampa; GA.: Atlanta; ILL.: Chicago, Downers Grove; IND.: Indianapolis; KANSAS: Kansas City (Mission); KY.: Louisville; LA.: New Orleans (Kenner); MD.: Baltimore, Rockville; MASS.: Boston (Wellesley); MICH.: Detroit; MINN.: Minneapolis (Hopkins); MO.: St. Louis; NEB.: Omaha; N.J.: Fair Lawn; N.Y.: Buffalo (Amherst), New York City, Jericho, L.I., Rochester, White Plains; OHIO: Cincinnati (Woodlawn), Cleveland, Columbus; PA.: Philadelphia; R.I.: Providence (Warwick); TEXAS: Dallas, Houston; WASH.: Seattle; WIS.: Milwaukee.

See them all at your nearest Heathkit
Electronic Center...or send for your
FREE Heathkit catalog below.

Heath Company, Dept. 110-9
Benton Harbor, Michigan 49022

Please rush my FREE '75
Heathkit Catalog.

Name _____

Address _____

City _____ State _____ Zip _____

Prices & Specifications subject to
change without notice.

*Mail order prices; F.O.B. factory. CL-523

CIRCLE NO. 5 ON READER SERVICE CARD



Build an
**ALPHA
BRAIN
WAVE
FEEDBACK MONITOR**

*You may be able to
learn how to relax
through electronics*

BY MITCHELL WAITE

THERE is nothing quite so pleasant as being able to relax completely whenever you want to. Unfortunately, today's quick pace rarely leaves us the time to truly relax.

Perhaps for that reason, scientists have come up with an electronic approach to relaxation that might revolutionize the art of "calming down." Drawing on knowledge of general psychology, eastern meditation techniques, and, in particular, clinical electroencephalography, researchers in the field of alpha-wave feedback have progressed rapidly in the last few years and made many significant gains.

Unlike the older forms of meditation, alpha-wave feedback requires neither an avatar or guru. Researchers have found that the minute brain-wave frequency band between 7.5 and 13 Hz is continuously produced in meditative stages of Yoga and Zen. This is called the "alpha state." The assumption is that the length and intensity of alpha-wave production is an impartial measurement of the ability to reach a special state of "relaxed awareness," found in certain types of meditation.

People who produce continuous alpha seem to experience a generally heightened sense of well-being, with a parallel increase in clarity. Thus, alpha feedback allows one to prepare for demanding mental tasks by previously clearing the mind of distracting thoughts and ideas. It is precisely for this reason that some businesses are investigating alpha feedback. Researchers are also suggesting that the "pain" of education can be lessened if these procedures are used in attention control. There is the possibility, they say, that recall can be improved and mental blocks avoided during examinations, by the use of alpha feedback.

Basic Approach. In alpha feedback, high-gain, low-noise amplifiers detect the micro-volt signals of the brain and use them to modulate a sound or other stimulus. The person training for increased alpha completes the feedback loop by listening to the rise and fall of a tone as the brain waves come and go. Thus, by learning to produce just the elusive 7.5-to-13-Hz modulation, a person can experience the alpha state.

Actually, all brain waves have charac-

teristic mental correlates. For example, deep sleep produces the long slow waves between 2 and 4 Hz; problem solving and daydreaming give rise to the theta rhythms (3.5 to 7.5 Hz); while tension, worry, or surprise produce the beta frequencies (13 to 28 Hz). There is also evidence that creative and spontaneous moods occur most often when the frequencies between alpha and theta are active. This has led some researchers to speculate that creativity and insight might be facilitated by learning how to increase frequencies.

The important thing is to find out more of all this for yourself. With the circuit described, you may be able to influence and enjoy all of the brain-wave states. In addition, the project can be used to listen to such body signals as scalp tension and heart rate.

About the Circuit. Because of the rapid increase in the popularity of biofeedback, a large selection of feedback monitors have appeared on the market. Their complexity ranges from a device for alpha feedback using only one IC to research laboratory equipment costing thousands of dollars. The latter include such features as strip chart recorders, multi-channel amplifiers, highly controllable filters, percent time indicators, etc.

The circuit shown in Fig. 1 incorporates functions usually found only in more sophisticated equipment. For example: because the different brain waves are very close in frequency, a switchable 4-pole bandpass filter is used. Each filter is tuned to the center frequency of the theta, alpha, and beta bands. These filters obviously make recognition of a particular brain wave much easier and faster.

Another critical parameter of a feedback machine is its ability to reject strong common-mode interference—such as 60-Hz hum or erroneous signals from electrode movement—while presenting a high input impedance. An inexpensive solution to this problem is to use a single low-noise op amp in the differential mode. This solution is not completely satisfactory because of the inevitable tradeoff among input impedance, balance, and common mode rejection. Here we use an instrumentation amplifier for the front end, with two low-bias op amps (IC1 and IC2) providing an almost infinite input impedance and excellent common mode rejection.

Electrodes, which couple the microvolt signals to the amplifier, are critical in two respects. They should not generate short-term voltages (tiny noise spikes) or long-term voltages (offset or drift). A number of low-cost commercial machines use an inert material such as stainless steel for electrodes. The difficulty with these electrodes is that they produce some noise spikes and (more seriously) generate a slow voltage offset, which (if the input stage is direct coupled) can eventually saturate the output. A better approach is found in laboratory applications where silver electrodes coated with a layer of chloride are used. Though these electrodes are free of noise and have no long-term voltage drifts, the chloride surface must eventually be replaced so the electrodes are disposable types. However, with proper cleaning, they will last for some time. The least troublesome approach is to use pellet-type Ag/Ag-Cl electrodes which, due to their special construction, last indefinitely.

Another more general consideration in designing an EEG monitor is the type of modulation used to produce the audio feedback. Most models use the amplified, filtered brain wave either to amplitude- or frequency-modulate a fixed tone. In the monitor described here, a unique combination tone-threshold control can be adjusted to produce either AM, FM, or a combination of the two.

It is also necessary to determine what aspects of the brain-wave envelope shall vary the tone. The two most common methods use either a direct or integrated waveform to modulate the audio. With the mode selector switch, S2, in the DIRECT position, the instantaneous waveform passing through the filter frequency modulates an adjustable tone. This mode creates an effect in which one seems to be tuning directly to the thought of the brain. If the continuous tone is objectionable, the oscillator can be set just below its threshold point so that only the peaks of the filtered waveform trigger the tone. The latter method integrates the filtered waveform over a fixed period of time.

In this monitor, depending on the setting of the threshold control (R42), the tone can be made absent when no signal is present. When the threshold is exceeded, the frequency of the tone is proportional to the envelope of the signals. This mode is better for biofeedback training since the

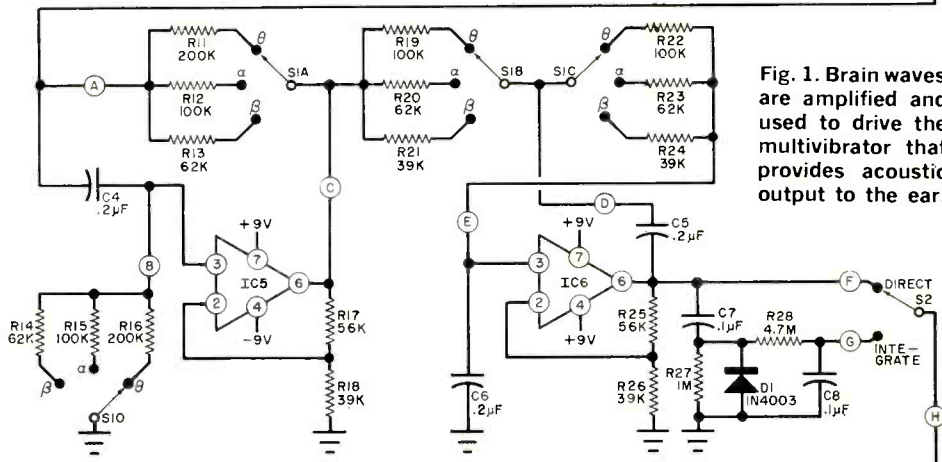
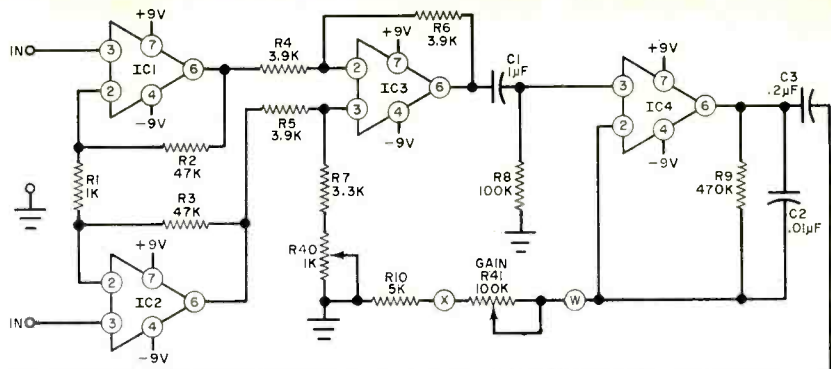
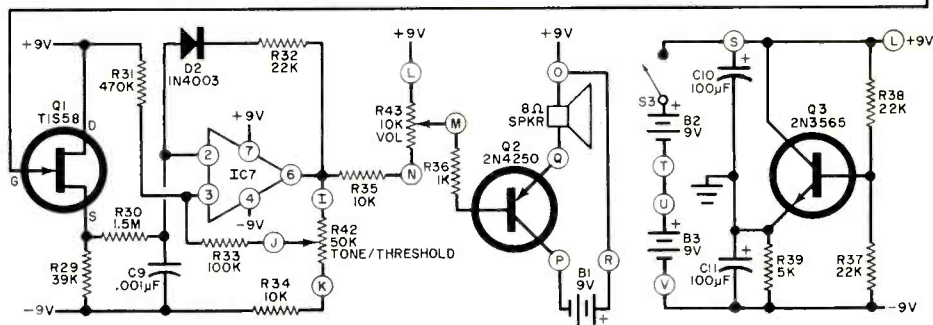

Fig. 1. Brain waves are amplified and used to drive the multivibrator that provides acoustic output to the ear.



PARTS LIST

- B1,B2,B3—9-volt battery
- C1—1- μ F, 10% Mylar capacitor
- C2—0.01- μ F disc capacitor
- C3,C6—0.2- μ F, 10% Mylar capacitor
- C7,C8—0.1- μ F, 10% Mylar capacitor
- C9—0.001- μ F, 10% Mylar capacitor
- C10,C11—100- μ F, 2-volt electrolytic capacitor
- D1,D2—1N4003 silicon diode
- IC1,IC2—N5556 op amp (Signetics, do not substitute)
- IC3-IC7—741 op amp
- Q1—TIS58 field effect transistor
- Q2—2N4250 transistor
- Q3—2N3565 transistor
- R1,R36—1000-ohm, $\frac{1}{4}$ -watt, 5% resistor

- R2,R3—47,000-ohm, $\frac{1}{4}$ -watt, 5% resistor
- R4-R6—3900-ohm, $\frac{1}{4}$ -watt, 5% resistor
- R7—3300-ohm, $\frac{1}{4}$ -watt, 5% resistor
- R8,R12,R15,R19,R22,R33—100,000-ohm, $\frac{1}{4}$ -watt 5% resistor
- R9,R31—470,000-ohm, $\frac{1}{4}$ -watt, 5% resistor
- R10,R39—5000-ohm, $\frac{1}{4}$ -watt, 5% resistor
- R11,R16—200,000-ohm, $\frac{1}{4}$ -watt, 5% resistor
- R13,R14,R20,R23—62,000-ohm, $\frac{1}{4}$ -watt, 5% resistor
- R17,R25—56,000-ohm, $\frac{1}{4}$ -watt, 5% resistor
- R18,R21,R24,R26,R29—39,000-ohm, $\frac{1}{4}$ -watt, 5% resistor
- R27—1-megohm, $\frac{1}{4}$ -watt, 5% resistor
- R28—4.7-megohm, $\frac{1}{4}$ -watt, 5% resistor
- R30—1.5-megohm, $\frac{1}{4}$ -watt, 5% resistor

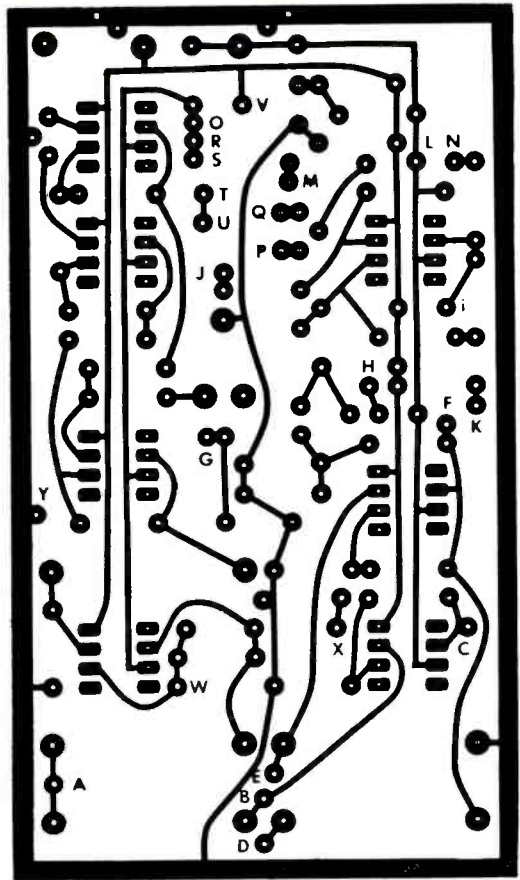
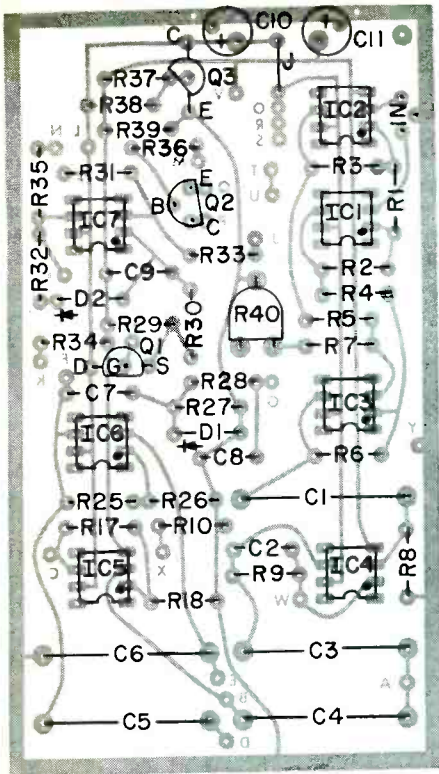

Fig. 2. Actual size foil pattern is at right with component layout above.

tone gives a direct indication of the desired result.

This monitor also has an audio amplifier with speaker and volume control (*R43*), so that a group can listen or the volume can be reduced to a quiet level.

How It Works. Integrated circuit *IC1* and *IC2* amplify the differential signal between

the two input leads while providing unity gain for the common mode signal. The residual common mode signal is removed by *IC3* and can be nulled to zero by trimmer *R40*. The signal is then coupled through *C1* to *IC4* and further amplified. The gain of this stage can be varied from about 5 to 95 by the setting of *R41*.

Integrated circuit *IC5* forms a two-pole

R32, R37, R38—22,000-ohm, 1/4-watt, 5% resistor

R34, R35—10,000-ohm, 1/4-watt, 5% resistor

R40—1000-ohm trimmer potentiometer (PC type)

R41—100,000-ohm miniature potentiometer

R42—50,000-ohm miniature potentiometer

R43—10,000-ohm miniature potentiometer with attached switch for *S3*

S1—4-pole, 3-position shorting rotary switch

S2—Spdt switch

S3—Spst switch on *R43*

SPKR—Miniature 8-ohm speaker

Misc.—Four feet of 2-conductor shielded flexible cable, metal enclosure, battery connectors (3), knobs (4), rubber grommet,

headband, electrode cream, electrodes, earclip, mounting hardware.

Note—The following are available (postpaid, but insurance extra) from Extended Digital Concepts, Box 9161, Berkeley, CA 94709: #EH2, etched and drilled PC board at \$5.95; #EH3, *IC1* and *IC2* at \$6.49; #EH4, set of stainless steel electrodes at \$1.98; #EH5, set of disposable Ag/Ag-Cl electrodes at \$3.98; #EH6, set of reusable Ag/Ag-Cl electrodes at \$14.95; #EH1, complete kit of parts including sets of disposable and stainless steel electrodes, drilled and etched board, drilled and painted enclosure, elastic headband, electrode cream, and earclip at \$68.95. Calif. residents, add 6% sales tax.

Photograph of prototype shows how components were assembled in box.

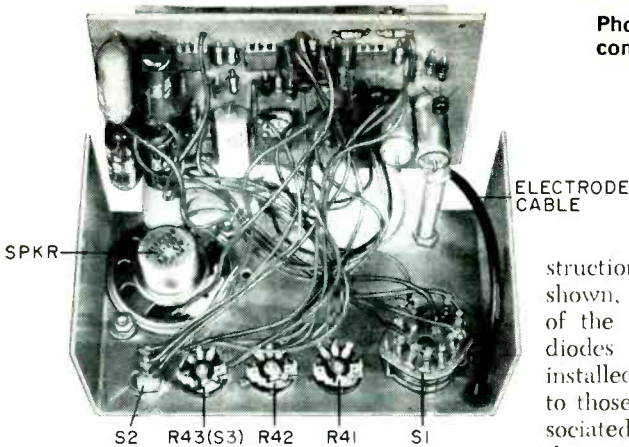

active filter which rejects signals lower than the frequency determined by capacitors $C3$ and $C4$ and $R11$ through $R16$. Conversely, $IC6$ removes signals higher than its selected frequency. The net effect is a filter which passes only a narrow band of low frequencies.

With $D1$ as a shunt rectifier and $C8$ and $R28$ as a smoothing filter, the signal is passed to $Q1$, a FET operating as a source follower with unity gain. Integrated circuit $IC7$ is connected in a multivibrator circuit and is normally saturated with the output voltage near the positive supply voltage. When $C9$ charges through $R30$ to a voltage higher than the level provided by the voltage divider made up of $R31$, $R33$, $R42$, and $R34$, $IC7$ saturates due to positive feedback. Capacitor $C9$ then discharges through $D2$ until $IC7$ flips back to its previous state. The signal from $Q1$ varies the charge on $C9$ and thus modulates the tone.

Transistor $Q2$ is a source follower which provides a low impedance to drive the speaker without overloading the multivibrator. A separate battery ($B1$) is used for the speaker to avoid feedback.

Transistor $Q3$ is a source follower which creates a low-impedance ground about half way between the plus and minus supply voltages. This also permits the use of a single-pole switch ($S3$) to turn the monitor on and off. It is not necessary to disconnect $B1$ because its drain is negligible with $S3$ open.

Construction. The use of a PC board (foil pattern shown in Fig. 2) makes con-

struction easy. Mount the components as shown, observing the notch and dot code of the IC's. Also make sure that the two diodes and three transistors are properly installed. The lettered terminals correspond to those on the schematic. The resistors associated with $S1$ are connected directly to the terminals on the switch. Use fine solder and a low-power soldering iron.

The circuit board and batteries can be installed in any small enclosure. The three potentiometers ($R41$, $R42$, and $R43$) and the two switches ($S1$ and $S2$) should be mounted on the front panel, with a small grommited hole also on the front panel for the shielded cable. The speaker is cemented to the front panel with a few holes drilled in the panel for the sound to come through.

Prepare the electrode cable by removing about 12" of the outer insulation from the cable. Unwind the shield and twist it into cable form. Solder this shield lead to the earclip. Remove about $\frac{1}{8}$ " of insulation from the two insulated leads and carefully solder them to the electrodes. When soldering to stainless steel, first lightly sand the metal surface with fine sandpaper.

Testing. Install fresh batteries, turn the circuit on, and adjust the tone/threshold control ($R42$) until a tone is heard in the speaker. Set the bandpass switch ($S1$) to its lowest range (3.9-7.9 Hz) and the mode control ($S2$) to direct. Using a small amount of electrode cream, clip the ground lead to an earlobe. Saturate the electrodes with cream, and steadily hold one electrode in each hand. The circuit should pick up your heartbeat, amplify it, and send it through the speaker. This is a noticeable beep, about one a second. The pulse signal is about 1 millivolt (10 times greater than alpha-wave level) so turn the gain control down. If you cannot hear your pulse, check the wiring.

If you have a signal generator and scope, the circuit may be further analyzed by clipping one input and the ground lead to the signal generator ground and feeding an attenuated signal into the other input lead.

The dc output of all op amps should be near zero.

Balancing the Amplifier. Potentiometer R40 is used to trim the gain of one side of the differential amplifier to make both gains exactly the same. When they are equal, common mode rejection is maximum. The best procedure is to feed a common mode signal of 3 to 4 volts into both inputs tied together, across a 10,000-ohm resistor. Put a scope or ac VTVM on the output of IC1 and adjust R40 for the smallest signal. If you do not have a scope or signal generator, hook the electrodes through the 10,000-ohm resistor to ground and touch the common leads. You will hear 60-Hz noise from your body. Adjust R40 for minimum noise or the clearest tone.

Use of the Monitor. First, a note of caution. The monitor, like most commercial machines of this type, is battery operated. This is to prevent a shock in the rare event that the 60-Hz power line shorts to the inputs. Therefore, for complete safety, avoid hooking the monitor to any ac-operated equipment such as scopes, battery eliminators, etc. When ac devices are hooked up to an EEG monitor in a laboratory, light coupling devices or fused fail-safe systems are used.

If you are sure the monitor is picking up EKG and properly balanced, you are ready to try EEG feedback. Place a small bit of electrode cream on the earclip and attach it to either earlobe. Wrap an elastic or soft cloth band around the head, aligned so that it is over the eyebrows and at the widest part at the back of the head. Pin the cloth to hold it on. Put a small amount of cream on each electrode and place one under the band just above the left or right eyebrow. Place the other in line with the first at the rear of the head. Spread the hair apart and add a little more cream. The electrodes will function best when they float above the scalp with electrode cream bridging the gap. With the electrodes placed in this manner, you should be picking up mostly what is called occipital alpha. In more advanced stages of meditation, alpha production increases in the frontal areas of the brain. You can experiment with this by placing both leads on the forehead.

Sit or lie down in a quiet, comfortable place. Turn the monitor on, place the band-

pass switch in the alpha range (7.9-13.0 Hz), with mode in DIRECT, turn the gain all the way down, and adjust the tone and volume to a pleasing level. Blink your eyes and listen for a beep. Slowly turn the gain up. If the electrodes are correctly placed, no hum will be heard. Now, with the eyes open and focused on an object, adjust the gain for a fairly steady tone. Because you are producing mostly beta and the band-pass is on alpha, you should not hear the beta frequencies. Now close the eyes and listen for a rhythmic modulation of the tone. Do not *try* to produce this rhythm; let the mind go and just listen for it. The occasional fluttering of the tone will be the alpha waves.

Notice the types of thoughts that block the alpha. After you are sure you are producing alpha, switch S2 to INTEGRATE and adjust the threshold/tone control so that, when the eyes are open, there is no tone. Shut the eyes and practice increasing the number of times the tone is on (percent time training). Later try increasing the frequency of the tone (amplitude training).

In laboratory training, a usual alpha session lasts 10 to 15 minutes a day for about two weeks. If you stick to it, you may eventually notice a feeling of well-being and relaxation after each session. To experiment with the other brain-wave bands, simply repeat the procedure with the filter switched to the desired band. Try lowering the dominant alpha frequency toward theta in the direct mode and notice if spontaneous thoughts or ideas come more easily.

When you have finished using the monitor, carefully wipe the cream off the electrodes. If you are using stainless steel electrodes, sand them lightly and clean them with alcohol.

One final note: alpha-wave feedback has produced results similar to meditation, but it works much faster. It is still, however, a subtle effect and requires diligence and experimentation to obtain worthwhile results. ♦

Editor's Note: This article describes an easily constructed project for experimentation. There have been many claims made for brain-wave monitors—some highly exaggerated. We make no such claims, other than that the circuit operates properly.

BY FRANK H. TOOKER

Special Tools for the Electronics Workbench

What tools you need, where
to get them, and how
they are used

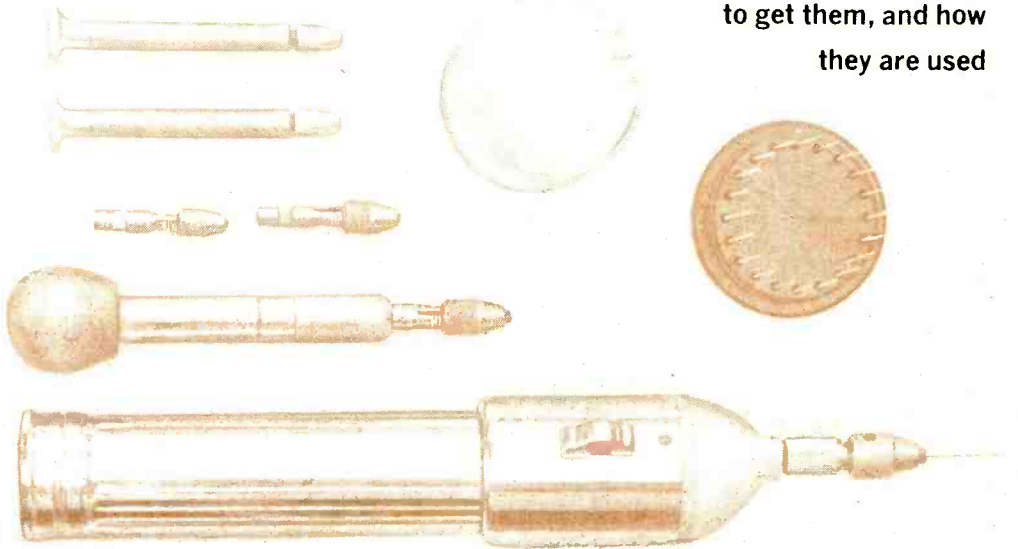

Shown are (top left) Moody pin vises, X-acto drill set (top right) and pin vise with interchangeable collets (center), electric drill (bottom).

TOOLS play an important role in the pursuit of the electronics hobby. Having the right tool for the job not only makes things easier, but it also usually makes for a neater and better performing project. But having the right tool does not necessarily mean that the user knows how to use it. Nor does knowing that a specialized tool is needed mean that the hobbyist will know where to find it.

While this article is concerned primarily with having the right tool for a given job, some attention is given to locating tools and how to use them. Emphasis is given to those tools of a

special nature—those not ordinarily found on the electronics workbench but necessary to performing certain special operations.

General Purpose Tools. Printed circuits are used almost universally these days, and fine drills are needed for making the numerous small holes in a PC card. The average drill set contains drills from No. 1 to No. 60 (0.228"-0.040" in diameter). All well and good, but for the most part, what are needed are drills much smaller in diameter than these. The most suitable ones for PC card work lie in the range of No. 61 to No. 80.



Fig. 1. To properly use battery-powered drill, when working on printed circuit boards, hold it perpendicular to work surface and apply minimal force.

You may never have heard of such drills, but if you plan to do PC jobs, you will need them—or at least enough of them to fill your needs.

X-acto Inc., famous as manufacturers of good hobby tools, make a set of fine drills. They are contained in a neat little stand, with drill size and diameter clearly labelled. The whole is topped by a clear plastic dome cover. You can buy X-acto drill kits from such dealers as Auto World Inc., 701 N. Keyser Ave., Scranton, PA 18508; E & H Model Hobbies, 160 W. Cheltenham Ave., Philadelphia, PA 19144; or from most well-stocked hobby department stores.

Individual drills, sizes 50 through 80, are available from America's Hobby Center, 146 West 22 St., New York, NY 10011 at 25¢ each plus shipping and handling. The size most frequently used for component lead holes in PC cards is a No. 67 drill.

Do not make the mistake of using the very fine drills in an ordinary $\frac{1}{4}$ " electric hand drill. You will only break one drill after another if you attempt to do so. For hobbyist/experimenter work, these drills are best used in a hand-held collet, otherwise known as a pin vise, or in a small battery-powered electric drill.

Shown on the opposite page are various drilling devices. The small pin vises—made by Moody—shown at the upper left are available from E & H Model Hobbies; the larger one, shown center with three interchangeable collets, is made by X-acto Inc.; the battery-powered electric drill, bottom, is available from America's Hobby Center and from Auto World Inc. Some or all of these items might also be available locally from major hobby centers.

A pin vise is useful where only two or three holes have to be made in soft materials such as plastic or for drilling holes in thin metal. For operations that require drilling many holes, the battery-operated drill is your best bet. Figure 1 shows the proper method of using the electric drill when working on PC boards. The two-handed operation allows precise positioning of the drill point and rapid transit from one hole location to another. Prick punch the center point of the hole, position the work about 15 in. below eye level, and make certain the area is well lighted before you begin. Also, when performing the actual drilling, apply only enough pressure to insure that the drill point bites into the work.

Batteries last a surprisingly long time in the drill; so, you may want to use the drill for such diverse operations as deburring and wire brushing the copper foil on a PC board before soldering.

You cannot very well use an ax to sharpen a pencil. It is equally impractical to use an ordinary hacksaw for working on miniature electronic assemblies. The saw shown at the left in Fig. 2 is undoubtedly the finest available for the equivalent of a hacksaw, and no other saw can do what this one does. It is called a "Zona" saw. It has very fine teeth and a blade thickness of only 0.008"—extremely thin by any standards.

The Zona saw is made of Swedish steel, a material that is tough rather than brittle. It will cut through anything from plastic to soft brass with surprising ease and speed. The blades themselves are replaceable.

There are three grades of Zona saws available. The No. 200 (shown) has 32 teeth/in., is $\frac{4}{8}$ " long, and makes a $\frac{3}{8}$ " deep cut. The No. 300 is coarser;

its blade has 24 teeth/in., is 0.015" thick by 6½" long, and cuts to a ⅞" depth. The No. 500 is a "big" saw; its blade has 32 teeth/in., is 0.010" thick by 6½" long, and cuts to 1¾"

A Zona saw will handle perhaps 75 percent of all cutting chores in electronics.

Specialized Tools. Shown at the right in Fig. 2 is a particularly useful tool. In fact, it is the only tool known to this author that will loosen epoxy-cemented parts. With this tool, a miniature component can be removed from a chassis or PC card to which it is cemented without damaging either component or its mounting. The tool, a hot knife, is a soldering-iron-like device that is fitted with a chuck and a special stainless steel blade instead of a soldering tip.

The hot knife cuts thermoplastic quickly, easily, and accurately. The ease and neatness with which it works is truly amazing. Some of the jobs that can be performed with the hot knife are cutting and shaping styrofoam blocks used for thermal insulation in temperature-controlled crystal oscillators, acoustic

DIAMETERS OF FINE DRILLS	
Drill Size	Diameter (in.)
61	0.039
62	0.038
63	0.037
64	0.036
65	0.035
66	0.033
67	0.032
68	0.031
69	0.0292
70	0.028
71	0.026
72	0.025
73	0.024
74	0.0225
75	0.021
76	0.020
77	0.018
78	0.016
79	0.0145
80	0.0135

insulation cutting for some speaker enclosures, and making clear plastic dial windows.

A couple of important points should be borne in mind when using the hot knife. First, make certain that the tool tip is up to temperature before attempting to make a cut. And, secondly, once you begin to cut, continue without hesitation until you are finished; if you stop, even for a second, you will produce a plastic blob that will mar the appearance of the work. Always clean the knife blade of any adhering plastic before allowing it to cool.

Do not attempt to use an ordinary hobby knife blade in the hot knife. Ordinary blades cannot bear up to the high operating temperatures without deteriorating.

Hot knives are available from such suppliers as Auto World Inc. and America's Hobby Center.

We have saved the best for last. Shown in Fig. 3 is the most unique, most diversified, and most useful and applicable tool to be found on any workbench. Compared to other power tools, its most unique feature is that it is so easy to make special accessories to fit it. Not only that, but this tool, plus the battery-operated electric drill discussed earlier, can make 95 percent of the average items used in miniature equipment—from scratch—including the cabinet that you use to house your electronic projects.

Fig. 2. Shown here left to right are Swedish steel Zona saw, replacement Zona saw blades, and hot knife tool.

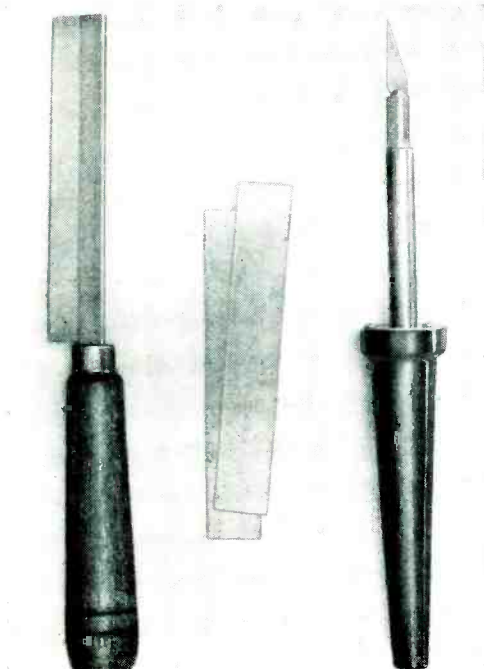

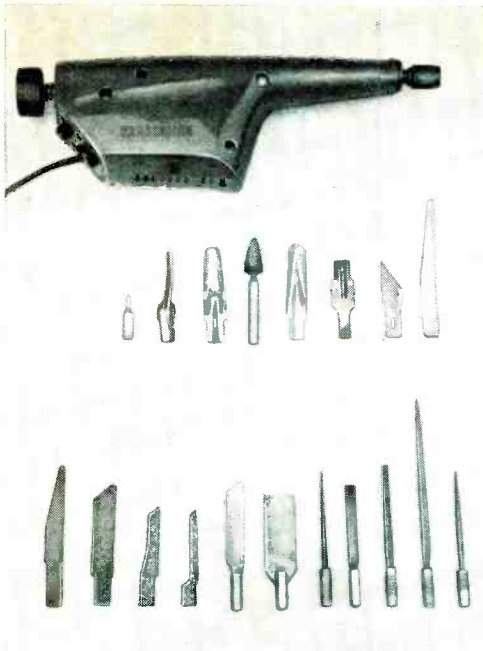

Fig. 3. Vibrator tool and accessories provided with it are shown arrayed above a row of homemade accessories.

This amazing tool is a reciprocating vibrator of the type used by jewelers for engraving jewelry. But it is much more powerful than the usual variety, and its stroke is continuously adjustable from zero to a full $\frac{1}{2}$ ". It has two operating speeds—3600 and 7200 strokes/min. The slow speed is of special value to the electronics hobbyist and experimenter; the high speed is used for engraving.

Shown immediately below the vibrator in Fig. 3 are the accessories that are supplied with the tool. Using these accessories, the vibrator tool will engrave, gouge, cut-carve, saw, and grind. The tool's chuck will also accept a large number of X-acto accessories.

The eleven accessories shown in the bottom row were home made, designed specifically for use in electronics work. The four items at the left end of the row are saws, made from lengths of ordinary hacksaw blade and contoured on a bench grinder. Their shank ends were shaped to fit the chuck of the vibrator, while the cutting ends were shaped to fit special job requirements.

The fifth accessory is also a saw, but

this time it is fabricated from a section of a Zona saw blade. It is slimmed, force-fitted, and soldered into a slot at the end of a $\frac{3}{4}$ "-long by $\frac{1}{4}$ "-diameter soft-brass shank. The accessory shown was made from a 0.008"-thick, 32 teeth/inch Zona blade.

The five accessories at the right end of the row are files. Intended primarily for working on metal parts, they are made from short or shortened Swiss needle files. The handles of each were cut off at the required length. Then the handle stubs were force-fitted into holes drilled in soft-brass shanks of the same dimensions used for the Zona blade.

The most valuable feature of the vibrator tool is that accessories, like the homemade files and saws, can be accommodated quickly and easily. If a particular file or saw is needed for a special application, it can be fashioned in a matter of minutes.

The accessory in the center of the row is a sander. It consists of a $1\frac{1}{4}$ " x $\frac{3}{4}$ " x $\frac{1}{2}$ " piece of mild-steel plate that was force-fitted and soldered into a slot cut across one end of a soft-brass shank. Normally, one side of the plate has a piece of medium-grit sandpaper cemented to it, while the other side has fine-grit paper.

The way you use the vibrator tool is of considerable importance. Bear down lightly, and move the tool slowly back and forth, all the while you are making a cut. If you hold the tool stationary or bear down too hard, you are likely to get nowhere.

The vibrator tool discussed here and shown in Fig. 3 is available from Sears Roebuck & Co., 4640 Roosevelt Blvd., Philadelphia, PA 19132.

No attempt has been made in this article to discuss such everyday, common tools as screw and nut drivers, soldering irons and guns, etc. These tools are all readily available from hardware stores and electronics parts dealers. Furthermore, they are so familiar to the hobbyist and experimenter that they need neither introduction nor instructions on their uses. One point, however, is an underlying credo of *all* tools: Use the correct tool at all times. Do not "substitute" one tool for another. Each tool was designed for a specific function; use it for that function and only that function. ◆

MODEL rocketry is currently one of the fastest growing of hobbies. Unlike slot-car racing and other fads that have come and gone in the recent past, model rocketry promises the hobbyist the type of permanence that has continued to draw new adherents to airplane modeling for decades. And it holds the key to new areas for experimentation for the electronics enthusiast.

With today's micro-technology and light-weight components, quite a sophisticated electronics package can be put together to make up the useful payload (weighing only a few ounces) of a typical model rocket. Enterprising electronics/rocket hobbyists are lofting (jargon for launching) live mice thousands of feet into the air and telemetering back to earth their temperatures, pulse rates, and breathing rates via tiny radio transmitters. Other experimenters are using similar transmitters to conduct meteorological (weather) studies, and still others are studying the performance of the rocket itself by means of simple accelerometers and sensors designed to monitor velocity and roll rate.

Getting Started in Rocketry. Model rocketry demands only a small cash outlay to get into the hobby. Simple kits for assembling a rocket, sans engine, are available for less than \$1, while rocket engines can be obtained for as little as 25¢ or less.

The beginner to model rocketry is advised to confine his first effort to a kit-built rocket to learn what goes into the design and fabrication of a rocket. As he gains experience, he can graduate to designing and building his own creations, making use of sturdy paper tubes, balsa and plastic nose cones and fins, and other accessories available from hobby shops. Most manufacturers of items for rocketry publish booklets and other literature detailing how to design rockets from scratch. Books on the subject often go into greater detail.

A typical home-made rocket consists of a 12-in. (or longer) paper tube that is 1 in. in diameter and is fitted with three 1/16-in. thick balsa stabilizer fins and a commercial balsa nose cone. A plastic dry-cleaning bag and some cord are often used to make a parachute, while an engine restraining block can be made from a sawed-off section of used rocket engine. The total cost for the materials might average about 75¢, depending on how much use can be made of make-do or salvage items.

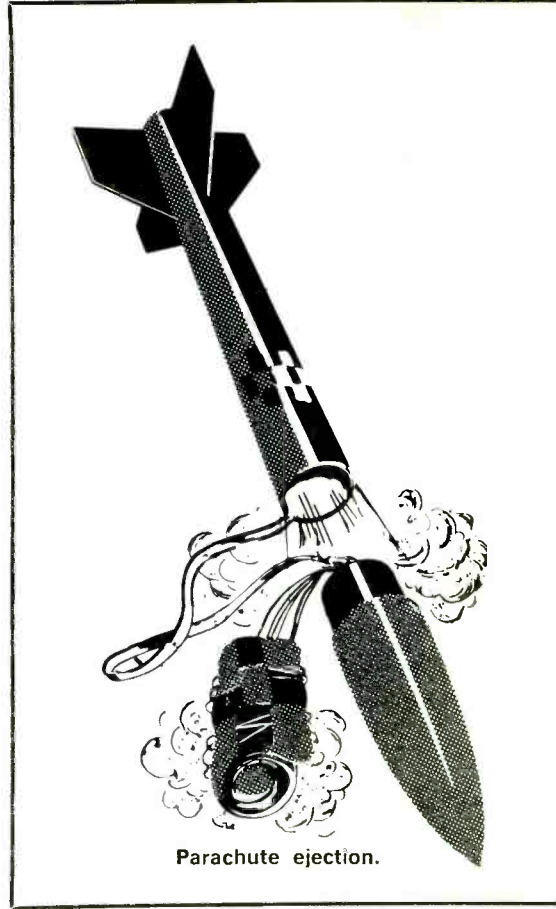

Parachute ejection.

A simple launch stand made from a 36-in. length of stiff piano wire, a metal flame deflector, and a base plate are used for lofting model rockets. One or two lugs cut from a plastic drinking straw and glued to the side of the rocket can be slipped over the piano wire to guide the rocket until its velocity is sufficient to provide aerodynamic stabilization from the fins.

For safety and efficiency, the rocket engine is ignited electrically from a remote location. The igniter is usually made from a 2-3-in. strand of Nichrome wire coated with a flammable plastic. The wire is inserted into the engine's throat and held in place with tape or wadded tissue. The free ends of the ignition wire go to a pair of clip leads that trail off to a spring-loaded normally open switch and 6-volt automotive or lantern battery.

When switch contact is made, the Nichrome wire heats rapidly, igniting the plastic which, in turn, ignites the engine

MODEL ROCKETRY for the Electronics Experimenter

*An exciting hobby and
an interesting
application of electronics*

BY FORREST MIMS

almost instantly. At lift-off, the rocket takes only a few seconds to attain a velocity of several hundred miles/hour. The engine burns out quickly, and the rocket coasts for most of its flight toward apogee (maximum altitude). Most engines have a slow-burning powder charge that produces a trail of white smoke. After this tracking charge burns out, a small explosive charge blows off the nose cone and ejects the parachute that returns the rocket back to earth.

Most hobbyists limit rocket lengths to 18 in., but more advanced hobbyists build rockets that sometimes exceed 36 in., weigh up to 1 pound, and use power plants capable of more than 20 pounds of peak thrust. There are dozens of types of rocket engines from which to choose, ranging from miniature ones for ultra-small rockets to brute-power ones for "muscle" rockets. The most popular engines provide an average thrust of about 1 pound for a burn time of 0.24 to 1.70 seconds. Engines are also available

without the parachute-eject capability for use in multi-stage rockets.

The most powerful rocket engines available are made by Centuri Engineering (see box) under the name Enerjet. While most engines employ a low-impulse compressed black powder charge, the Enerjet uses a high-impulse composite propellant (fuel-and-oxidizer mixture). These core-burning engines provide an average thrust of about 15.1 pounds for 1.2 seconds, enough to send a 1-pound rocket and payload to an altitude well in excess of 1000 ft. Truly professional engines, the Enerjets have epoxy casings and machined graphite nozzles.

Enter Electronics. The launch of a "bare-bones" rocket provides little scientific data. The real fun comes when a rocket is equipped with instrumentation, telemetry, live payloads, and rocket cameras. Estes was one of the first and is currently the largest of the manufacturers of model rocket supplies and engines. Their Transroc transmitter weighs only 1.3 ounces, including battery, but it can be used in a wide variety of applications.

The Transroc transmitter can be used to telemeter temperature or roll-rate information or as a homing-signal beeper for locating downed rockets. It can also be used with a crystal microphone to send back to earth such sounds as the roar of the engine, the rush of air past the fuselage during the coasting phase, the noise of the chute's ejection, and the sound of the chute cords' rubbing against each other on the way down. Other transmitters and modules are available from Astro-Communications, Prime Recovery Systems, and Microdyne Electronics.

Besides telemetry, a simple transmitter system can be quite useful as a tracking beacon (also helps locate lost kids!) for downed rockets. A rocket only a few feet long and 1 in. in diameter can get lost fairly easily during launch, especially on a windy day. The optimum recovery system consists

Warning: Before launching rockets, check your local authorities for maximum altitudes permitted in your area and any other safety conditions that may apply. Also, remember that a rocket engine is potentially very dangerous and extreme care must be used when storing, transporting, setting up, and igniting.

of a miniature transmitter (in the rocket), a receiver, and a loop antenna.

Tracking is the basic application of the telemetry transmitter. Roll rate, for example, can be measured by connecting a photocell to a transmitter so that variations in its resistance cause an audio tone to vary in frequency. The photocell is mounted in the payload section in a manner that permits light to enter from only one side so that each revolution results in the transmission of a complete tone cycle to a ground receiver as the cell alternately faces toward and away from the sun. A tape recorder can be



A wide variety of rocket engines are available for model rockets. Larger ones shown here are capable of supplying more than 20 pounds of thrust, while smaller ones have thrust of a few pounds. All engines are equipped with an exploding powder charge for parachute ejection. The larger units have machined graphite nozzles; smaller ones have ceramic or clay nozzles.

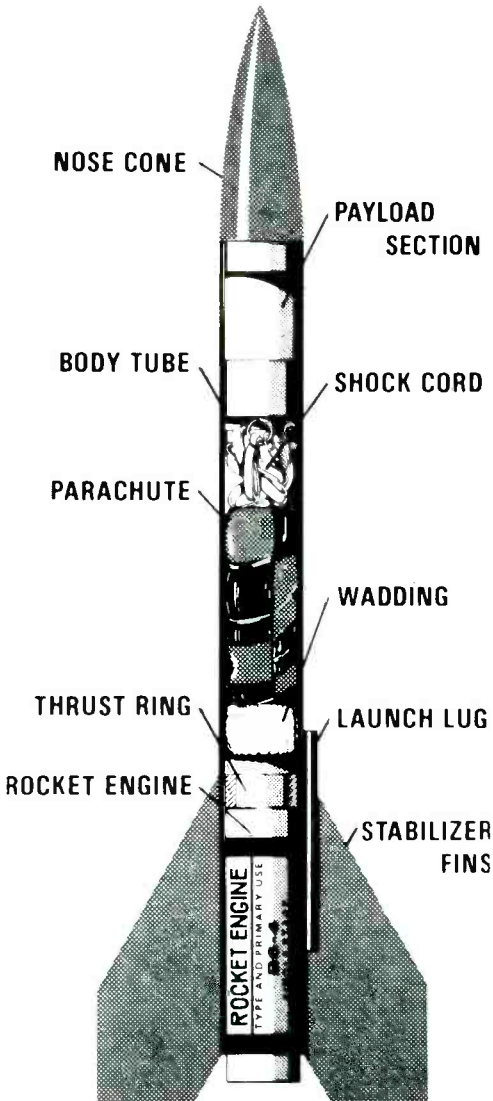

A model rocket is a real flying model of a research or space booster rocket.

used to record the signal for later study.

A slide-type potentiometer with its wiper attached to a spring or rubber band and a small weight can be used to measure acceleration. As the rocket accelerates, the wiper contact slides back and changes the modulation of the transmitter. As the rocket slows down, the spring or rubber band returns the wiper to the neutral position. To calibrate the accelerometer potentiometer, a number of small weights are hung from it to pull against the spring; with each weight addition, a frequency measurement is made and logged.

Velocity can also be measured if care is used in designing an appropriate sensor. One technique you might want to try is a pressure-sensitive device that consists of two thermistors in a bridge circuit (one inside the rocket, the other outside). Another is a small propeller that sends back one pulse for each revolution made. Velocity sensors are calibrated in homemade wind tunnels or are mounted on the outside of a car and monitored at a range of highway speeds for the results yielded. If acceleration is known with respect to time, velocity can be calculated and used to calibrate or check a velocity sensor.

Sensors can also be used to monitor the pulse and breathing rates of animal payloads. For example, a roll-rate sensor that employs a photocell can be arranged so that

it responds to variations in light intensity effected by the moving thorax of a breathing mouse. Light can be supplied by a small lamp mounted on the side of the mouse opposite the photocell. A similar technique can be used to monitor pulse, the photocell and light source being placed on opposite sides of the mouse's tail or ear. Blood flow variations during each heartbeat attenuate the light getting through and modulate the transmitter.

Transmitters are not the only electronic payloads that can be launched in a model rocket. Perhaps the simplest of all payloads is the solid-state light flasher that permits a rocket to be launched at night for a very unusual and spectacular sight. A night launch provides an inexpensive, yet reliable, method of obtaining useful scientific data about the flight characteristics of a model rocket. The usual technique is to photograph the rocket's flaming trail with a camera set for time exposure so that the trail leaves a distinct track across the film. When the engine burns out, the light flasher can be seen and recorded on the film. Also, if the flash rate is known, it is possible to measure the rocket's velocity by counting the number of flashes during a given portion of the flight.

Even the flame trail can be used to obtain velocity and acceleration data. To do this, a strobe disc is placed in front of the camera's lens so that, when the disc is rotated at a fixed speed, the flame trail's track on the film is divided into a series of

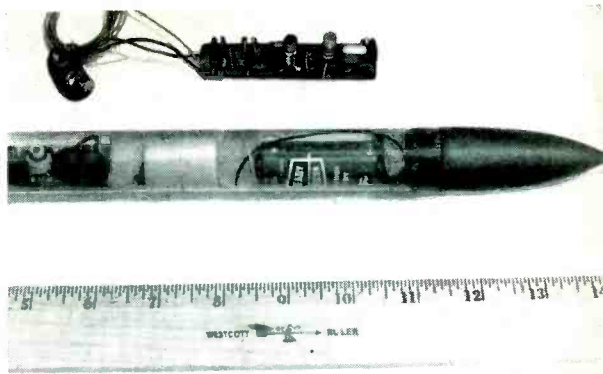

Here are two telemetry transmitters marketed by Micro Instrumentation and Telemetry Systems, Inc. (MITS). Unit above rocket payload capsule is a relatively inexpensive kit, while the one mounted in capsule is a factory-built unit. Both operate in Citizens Band.

streaks. By using simple photometries and knowing the time duration of each streak, it is possible to measure velocity, acceleration, and altitude at various points along the flame trail.

The flasher also facilitates rapid recovery of the rocket during night launches. The darker the night, the faster the recovery.

Photography In Rocketry. Of equal importance with instrumentation in model rocketry is photography. Simple single-frame still cameras, activated by the force of the parachute-ejection charge, were developed in the late 1950's. Several years ago, Estes Industries introduced the Camroc, a single-shot plastic camera. This simple but sturdy camera has since been used to take high-altitude photos of landscapes, housing developments, agricultural areas, etc., and in a lot of serious amateur scientific work.

An even more exciting development came in 1970 when Estes introduced their Cineroc super-8 color movie camera. This 3-ounce camera is powered by two miniature penlight cells and accepts a cassette of color film made especially for the camera. A moving picture taken from a model rocket in flight is truly spectacular.

The film begins with an out-of-focus hand that moves off the screen. A few seconds later, a puff of smoke below the fins signals ignition. A moment later, a large cloud of smoke and a tinge of flame signal lift-off. The rocket rises with startling speed; the launch rod is gone in an instant, and



Several companies produce telemetry equipment for model rockets. Shown is Transroc, a kit operating on the Citizens Band with range of several miles paired with superhet receiver.

then the launch crew and spectators come into view, only to rapidly disappear from the screen as the rocket zooms up to apogee. The most exciting part of the flight occurs when a two-stage rocket is used to loft the Cineroc. The first stage can be seen in intimate detail as it separates from the second stage in a burst of smoke and flame. The drifting, tumbling first stage, its top spouting orange and yellow fire, is reminiscent of NASA film clips that show stage separation of full-size rockets.

MODEL ROCKET MANUFACTURERS

Below are some of the larger companies that make model rockets, engines, and electronic telemetry and photographic equipment. On request, they will forward information about their products and general literature on rocketry.

Astro-Communications
3 Coleridge Place
Pittsburgh, PA 15201

Centuri Engineering Co.
Box 1988, Phoenix, AZ 85001

Estes Industries, Inc.
Box 227
Penrose, CO 81240

Microdyne Electronics
P. O. Box 477
Bozeman, MT 59714

Prime Recovery Systems
P. O. Box 84
Lansing, MI 48901

The National Association of Rocketry offers membership to anyone interested in model rocketry. The association sponsors a variety of conventions and launches. Model rocketeers compete in contests similar to those held for model aircraft hobbyists. The association also sponsors competition in research and development. For more information, write to:

National Association of Rocketry
Box 178, McLean, VA 22101

The Southwest Research Association (SRA) sponsors an annual summer study program at the University of New Mexico with emphasis on both theoretical and experimental model rocketry. Study topics include advanced mathematics, computer programming, aerodynamics, electronics, telemetry, and experimental design. Students are required to plan and execute an original research project involving some aspect of model rocketry. For more information, write to:

James P. Miller, Chairman SRA
Math Department
University of New Mexico
Albuquerque, NM 87106

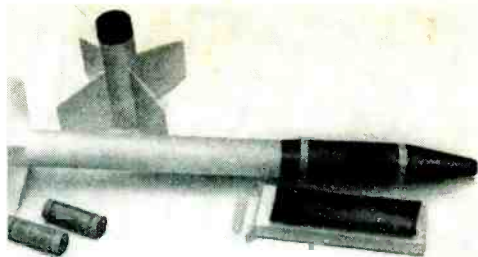

One of the most spectacular developments in model rocketry is the Cineroc movie camera shown here. Constructed of sturdy black plastic, camera has enough 8-mm color film to record over 20 seconds of high-speed rocket flight. Camera shown here is mounted on a carrier rocket. The stubby, four-finned section to the rear is rocket's first stage booster. In front are two engines and plastic encased film holder.

The camera can be rigged to its parachute so that it points upward, downward, or at any intermediate angle. The upward shot is an interesting sequence of the parachute unfurling, popping open, and slowly oscillating back and forth on the way down. Downward shots produce dramatic views of the earth as the natural oscillations of the chute continuously change the view. Some downward shots have even been known to produce a touch of nausea for the ground-bound observers when the film was shown.

Model rockets, engines, and launch stands are relatively inexpensive. Rockets can be assembled from raw materials, purchased as kits, or bought ready to fly. Instrumentation costs can range from a few dollars for a light flasher to about \$20 for the Cineroc color movie camera. A low-cost walkie-talkie receiver can be used to pick up the signals from most commercial model rocket telemetry transmitters (a few operating outside the CB channels, but most on the CB band); and any portable tape recorder will enable the experimenter to preserve the telemetry signals. An inexpensive Polaroid camera can be used to photograph night-time launches.

You can find out more about model rocketry by writing to some of the manufacturers listed in the box or by visiting a hobby shop that caters to rocketry enthusiasts. After you have launched a few rockets of your own, you will almost certainly want to go on to instrumentation and photography. Good luck and safe flying. ♦



BUILD A

175-MHz PRESCALER

EXTEND YOUR 20-MHz DIGITAL FREQUENCY
COUNTER TO WORK AT 175 MHz

BY DANIEL MEYER

DIGITAL readout frequency meters capable of indicating to about 20 MHz are now becoming widely available at reasonable prices. There are a few that can reach 50 MHz, but if you have to go higher than that, the price really starts to climb.

However, by taking advantage of the latest developments in IC's, it is very easy to build a new divide-by-ten front end for less than \$35. This will permit the use of limited-range counters at frequencies up to 175 MHz.

The new type of IC uses what is called emitter-coupled logic (ECL), which operates considerably faster than the TTL types now used in most counters. The high operating speed is obtained by never letting the internal transistors be driven into saturation. This eliminates the storage time delays that slow down TTL and DTL types. There are flip-flops available that can be used for counting speeds over 500 MHz. Although the Fairchild ECL-9528 dual flip-flop used here is specified for 160 MHz, in testing the Prescaler circuit, no samples were found that would not operate to 175 MHz.

Theory of Circuit Design. A schematic of the Prescaler circuit is shown in Fig. 1. The input high-frequency signal is suitably attenuated in *R1* and applied to the first IC through *C1* and *R2*, which provide

dc isolation and overload protection for the IC. Resistors *R3*, *R4*, and *R5* are used to bias the input gate to the mid-point of its switching levels and to provide an input impedance approximating 50 ohms—the optimum value.

Diodes *D6* and *D7* clip any signal that goes positive or exceeds the supply voltage in amplitude. The first flip-flop (half of *IC1*) simply divides by two and passes the signal to the next three flip-flops (second half of *IC1* and both halves of *IC2*) which are connected to form a synchronous divide-by-five circuit. The output signal is amplified by *Q1* to provide sufficient drive for almost any type of counter.

Construction. It is best to assemble the Prescaler on a printed circuit board having the foil pattern shown in Fig. 2. Be sure to observe the terminal markings on the semi-conductors and use a low-power soldering iron and fine solder to avoid thermal damage. The input and output connectors, transformer *T1* and filter capacitor *C4* are mounted on the metal chassis as shown in the photographs. The circuit board is mounted on four spacers.

Testing, Adjustment, and Use. Apply a signal with frequency over 20 MHz and a level between 0.5 and 2 volts rms to the in-

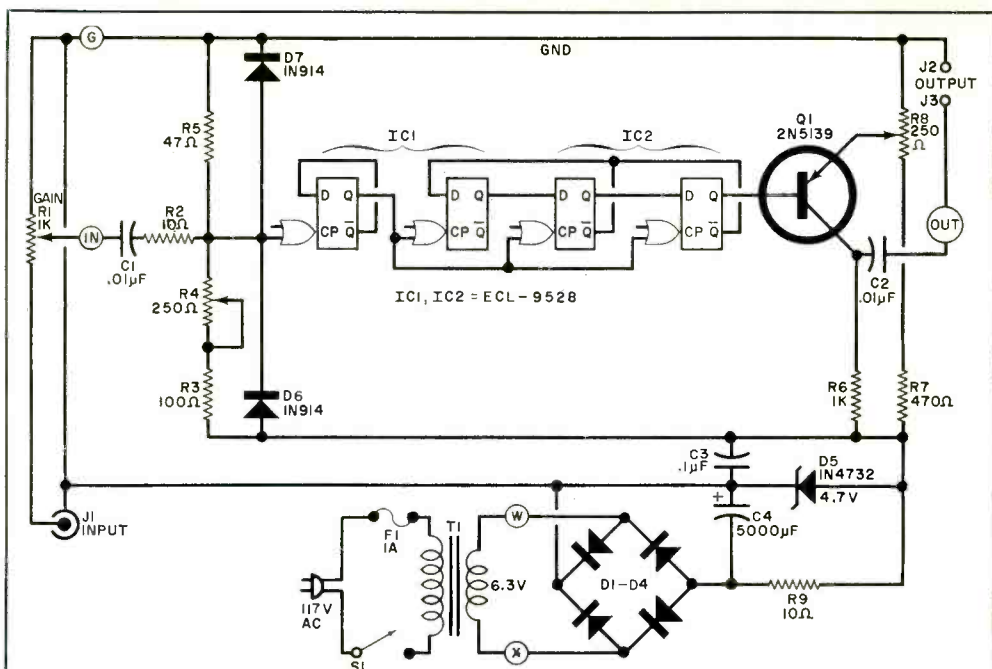

Fig. 1. The Prescaler is essentially a high-frequency divide-by-ten circuit which enables a 17.5-MHz frequency counter to indicate up to 175 MHz.

PARTS LIST

C1,C2—0.01- μ F disc ceramic capacitor
 C3—0.1- μ F disc ceramic capacitor
 C4—5000- μ F, 10-volt electrolytic capacitor
 D1-D4—1A silicon rectifier diode
 D5—4.7-volt zener diode (1N4732 or similar)
 D6,D7—1N914 diode
 F1—1A fuse and holder
 IC1,IC2—Dual flip-flop (Fairchild ECL-9528)
 J1—BNC connector
 J2,J3—Five-way binding post (one red, one black)
 Q1—2N5139 transistor
 R1—1000-ohm potentiometer with S1 attached
 R2—10-ohm, $\frac{1}{2}$ -watt resistor
 R3—100-ohm, $\frac{1}{2}$ -watt resistor

R4,R8—250-ohm PC potentiometer
 R5—47-ohm, $\frac{1}{2}$ -watt resistor
 R6—1000-ohm, $\frac{1}{2}$ -watt resistor
 R7—470-ohm, $\frac{1}{2}$ -watt resistor
 R9—10-ohm, 1-watt resistor
 S1—Spst switch on R1

T1—Transformer: secondary: 6.3V, 600mA
 Misc.—Suitable two-piece chassis, line cord, grommet, knob, board spacers, mounting hardware, capacitor clamp, etc.

Note—The following are available from Southwest Technical Products Corp., Box 32040, San Antonio, TX 78216; drilled and etched PC board #177 at \$2.37, postpaid; complete kit of all parts including punched chassis a \$33.75, plus postage and insurance for 2 lb.

This photo shows how prototype Prescaler was assembled in small chassis.

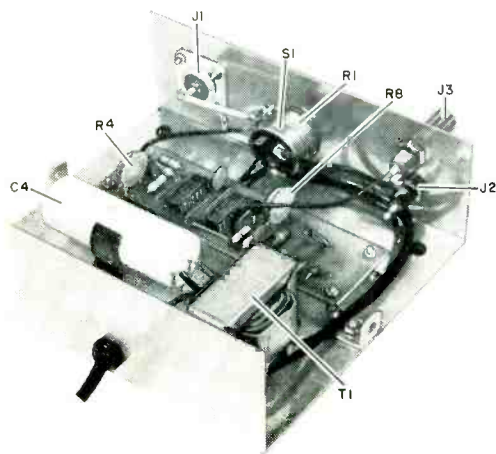

put. Connect the output to an oscilloscope. Turn on the Prescaler (via S1 on R1) and adjust R1 until a pulse waveform is displayed on the scope. If it is not possible to do this, leave R1 at maximum and adjust R4 and R8 to obtain the desired display. Then adjust R1 to reduce the input level and set the two controls on the board to produce an output with as low an input signal as possible. It is best to adjust these controls with an input signal of about 100 MHz since the adjustments are slightly frequency dependent. The adjustments may be broad at low frequencies, becoming more critical as the frequency is increased.

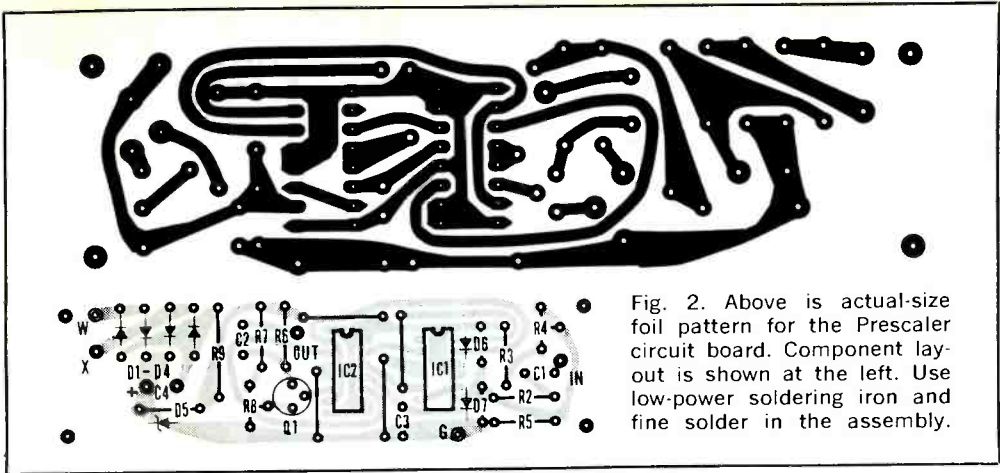

Fig. 2. Above is actual-size foil pattern for the Prescaler circuit board. Component layout is shown at the left. Use low-power soldering iron and fine solder in the assembly.

In using the Prescaler and connecting an external signal to the input, always set *R1* for the minimum useful signal. Even with the protective diodes, a very large voltage level at the input could destroy the IC's.

When connecting the Prescaler output to a counter, note that *J2* is the ground connector. Set the frequency counter to the kHz position and remember that, with

the Prescaler added, all values will indicate one digit to the right. That is, with an input of 15 MHz, a conventional five-digit counter will indicate 15000 kHz. With the Prescaler added, the indication will be 01500 kHz. An input frequency of 175 MHz will show up as 17500 on the kHz range. If your frequency counter has a MHz range, it may be used, but you must still keep track of the decimal point mentally. ♦

SIMPLE THUMP AND RUMBLE FILTER

IF YOU do a lot of home or on-location tape recording using a microphone, you know how annoying and amateurish your tape can be when the sound played back is loaded with "thumps" and rumbling noises. Even one thump or short rumble roll can be a downright nuisance. However,

there is a simple method of practically eliminating any of these noises. All you need is a square of soft foam plastic (not the rigid kind used for arranging floral decorations or the type used in many kitchen sponges that turn rock hard when dry). Cut the foam plastic to about 6" × 6". For best

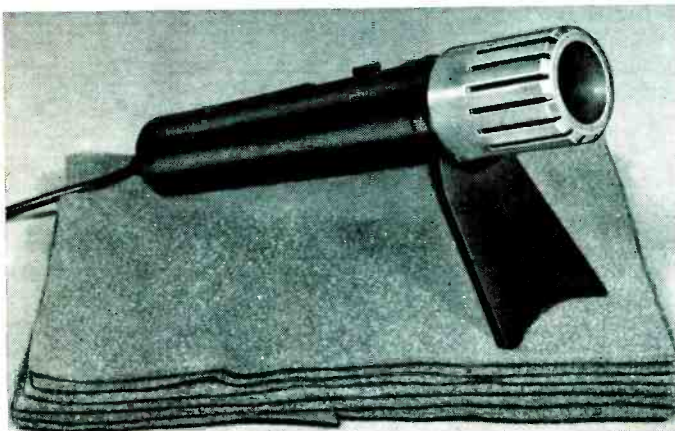

results, the foam plastic should be 1/4" to 3/8" thick. Just set the plastic foam pad on a solid surface, and place the recording microphone on the pad. You're ready for your next taping session. You'll be pleasantly surprised at how little background noise the mike picks up.

—Frank H. Tooker

IF YOU are guessing at enlarger exposures to save time, chances are you probably are wasting quite a bit of projection paper. On the other hand, you may be spending too much time running test strips to avoid wasting the paper.

In either case, you will want to consider building an adapter for your VTVM or TVM that indicates exposure times from 1 to 100 seconds using the ohms scale on the meter. You have to add one connector and one lead within the meter, but this will not affect conventional operation.

With linear operation for maximum versatility, the 10,000:1 range of the meter adapter covers almost any situation. You can use the adapter for integrated light or the spot method. A variable-sensitivity control permits programming the meter to accommodate different paper speeds and alternate modes of operation. The meter also provides a direct readout of negative contrast.

Theory of Operation. The adapter can be used with any VTVM or TVM having a 10 at the center of the ohms scale and an RX1 megohm range. The basic ohmmeter circuit usually includes a range resistor (*R* in the schematic) selected by the ohms-range switch.

The resistance of *PCI* decreases in direct proportion to the applied light level. The photoresistor called for in the Parts List has a very high dark resistance, fast response, and a flat color temperature response over a wide range, so substitutions should be made accordingly. Potentiometer *R1* and resistor *R2* are connected across the ohmmeter range resistor to provide the variable sensitivity. It is this that makes possible the calibration of the meter for direct readout of exposure time on the ohms scale. Pushbutton switches *S1* and *S2* facilitate the zero and full-scale meter adjustments.

Construction. The adapter can be mounted directly on the cover of a small plastic case, with *R1* at the center and the two switches on the bottom corners. Mount *J1* at another corner, while the three-wire cable should exit through a grommeted hole at the fourth corner. With an ohmmeter, check that resistance variation of *R1* is smooth for its entire range. A 0-100 dial plate is used in conjunction with a marked knob to set *R1* to any desired point. Index the pointer to zero with *R1* set fully counterclockwise.

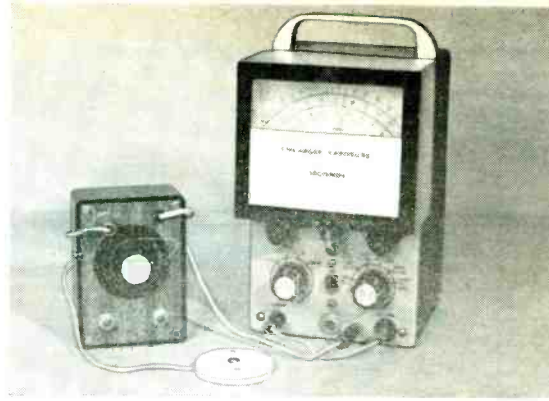

Photosensitive resistor *PCI* is mounted between two small pieces of insulating material such as plastic or insulation board with the sensitive surface exposed through a hole. After connecting the cable to *PCI*, and closing the "sandwich," paint the enclosure (not the sensitive *PCI* surface) white.

If you want to illuminate the meter face for darkroom operation, use cardboard or sheet metal to form a slip-on meter hood as shown in the photo. To illuminate the meter face, use a #49 pilot lamp, tinted red and in series with a 72-ohm resistor, connected in parallel with the existing meter pilot lamp. Or you can use an external transformer to provide the necessary power for the lamp.

Checkout. You can verify cell linearity and meter scale tracking using the enlarger aperture control to change light levels by known ratios. Set the meter to OHMS in the RX1 megohm range. When the meter is warmed up, depress *S1* to zero the meter. Release *S1* and depress *S2* to set the meter to full-scale.

PARTS LIST

- J1*—Miniature phono jack
- PL1*—Miniature phono plug
- PCI*—CdS high-speed linear photoresistor (Clairx (L705HL, or similar)
- R1*—5-megohm audio taper potentiometer
- R2*—47,000-ohm, 1/2-watt resistor
- S1*—Spst, normally open pushbutton switch
- S2*—Spst, normally closed pushbutton switch
- Misc.—Small plastic case with cover, 0-100 dial plate, pointer knob, length of three-conductor flexible cable, length of two-conductor flexible cable, plastic for *PCI* mount, rubber grommet, optional meter hood and illuminator.

BUILD AN

ENLARGER TIMER

PUT YOUR VTVM TO WORK
IN THE DARKROOM

BY ADOLPH A. MANGIERI

With $R1$ set to maximum resistance and with enlarger and all darkroom lights off, the meter should indicate near infinity after the cell stabilizes. Avoid exposing the cell to strong room light during calibration and use. If necessary, position the meter so that stray light from the illuminator has little or no effect on meter indications.

Place a normal contrast negative in the enlarger. For a 35-mm negative, allow about 14 inches between lens and easel. Move the lens aperture lever from maximum to $F/5.6$ to take up any backlash. With $R1$ set at about $\frac{3}{4}$ rotation, position the cell so that the meter indicates 4 seconds. Move the lens aperture lever to $F/8$ and $F/11$ and observe meter indications of about 8 and 16 seconds. Similarly, with lens at $F/5.6$ and meter initially set to 16 seconds, move the lever to $F/8$ and $F/11$ and observe indications of about 32 and 64 seconds.

Calibration and Application. To calibrate the exposure meter, find and record the setting of $R1$ for the projection papers in use by means of conventional test prints. Record paper data and $R1$ settings in a notebook.

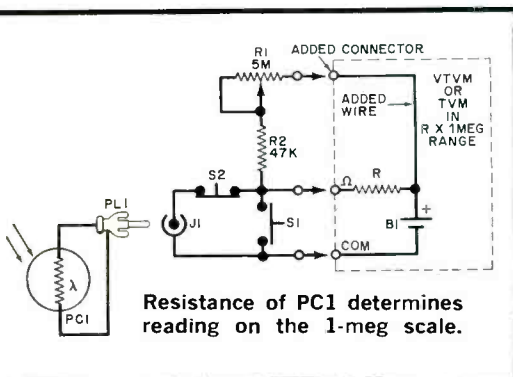

Select a negative of normal contrast and make the best possible print by the conventional test-strip method. Let's assume the best print was exposed for 15 seconds at $F/8$.

For the integrated light method, place the cell at the center of the projected image. Hold a ground glass plate at the enlarger lens to scatter the light. Adjust $R1$ until the meter indicates 15 seconds and record the setting. To use the meter at any print magnification or lens aperture, set $R1$ as recorded, use the light scatterer, and expose for the indicated time.

Next, set the lens aperture to $F/5.6$ or one stop larger. Find a second setting of $R1$ for a meter indication of 15 seconds. To use the meter at this setting of $R1$, measure the exposure time at a chosen aperture, close down one F stop, and expose for the measured time. Or, you may halve the indicated time and expose at the same aperture. Similarly you can calibrate $R1$ for measurements at two stops larger and close down two stops before exposing at the measured time. If needed, use these alternate calibration points to accommodate large blowups of dense negatives. They are also useful with enlargers having unusually small lamps.

A second mode of operation bases exposure time on a single spot measurement at the shadow area of the print. Reset lens aperture to that of the test print ($F/8$). Place the cell at the bright portion of the image and adjust $R1$ for an indication of 15 seconds. It's best to avoid measurements at blocked-up blacks which appear as blank areas on the negative.

As an aid in selecting paper contrast grade, check negative contrast as follows. Place the cell at the bright portion of the image. Adjust lens aperture and $R1$ until the meter indicates 1 second (reference point). Position the cell at the dark portion of the image and note the indication, say 12 seconds. Directly, negative contrast is 12. By test prints, establish your own correlation between prints contrast measurements and required paper contrast grade. Negatives with contrasts of 8 to 16 will print on normal contrast paper.

You may prefer to devise other calibration procedures. For portraits, calibration can be based on measurements at important areas such as the subject's face. Or, you can base calibration on the average of highlight and shadow measurements. ♦

flash tubes

UNDERSTANDING
AND GETTING THE
MOST FROM STROBES

OPERATION & APPLICATIONS

IT IS a simple device, the flash tube; but it is often regarded with awe—perhaps because many people don't understand just how and why it operates. A flash tube is nothing but a sealed glass or quartz tube, filled with an inert gas (such as xenon) and

tube and connected to a high-voltage pulse source. When a trigger pulse occurs, some of the xenon in the tube is ionized, allowing some electrons to flow through the gas. When this occurs, the remainder of the gas in the tube is ionized and the capacitor discharges quickly through the tube. The result is a flash of bright light.

The flash tube remains in the conducting state until the storage capacitor is fully discharged. Series resistor $R1$ prevents the power supply from providing enough current to keep the gas ionized after the flash. This avoids what is called "holdover", which can destroy the tube when it occurs.

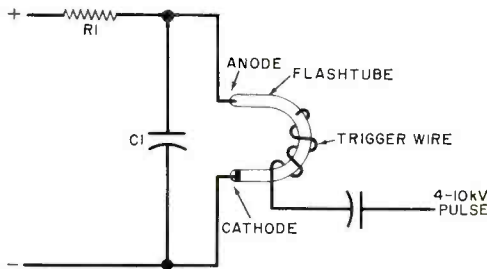

Fig. 1. In basic flash-tube circuit, $C1$ discharges through tube, after a trigger pulse partially ionizes gas.

Determining Flash Duration. When the flash tube is in the conducting state, it has a very low resistance (about 6 ohms for a tube of short length) and this value is used to determine the flash duration. An approximate equation is $T = RC/2$, where T is the flash duration in seconds, C is the value of the storage capacitance in farads, and R is the equivalent resistance of the tube in ohms. The equivalent resistance of the tube depends largely on the distance between the cathode and anode electrodes, so the longer the tube, the higher the resistance.

For conventional photographic work, a flash duration of approximately 1 millisecond is required. For this application, then, a high capacitance and high flash-tube resistance are required.

When the xenon is ionized, an electron of a xenon atom is raised from its "ground" (lowest) state to some excited state. The atoms can only remain in the excited state for approximately 9 nanoseconds. When the atoms return to the ground state they radiate energy in the form of light or photons. According to Planck's Law ($E = hv$), the

having an electrode at both ends. The tube is unique in that it can provide a white light of high intensity for a very short time, which makes it ideal for use in vehicle and obstruction warning lights, high-speed photographic accessories, ignition timers and stroboscopes. It is also useful because it comes in a range of sizes: from a 1-inch tube for portable electronic flash attachments to 15-inch water-cooled units for pumping high-energy lasers.

So, how about the circuit that provides the driving voltage for a flash tube? It is also simple; a typical one is shown in Fig. 1. A high-voltage dc source (300 to 3000 volts) puts a charge on capacitor $C1$ through series resistor $R1$. A thin wire (called the trigger) is wrapped around the

frequency of the photons is directly proportional to the energy state of the atoms. Since the excited atoms are in discrete, or "quantized" energy states, the resultant photons are of discrete frequencies.

Flash tubes are usually manufactured in three styles: linear, U-shaped, and helical. Parameters are generally specified according to: minimum-to-maximum voltage across the tube, minimum trigger voltage required to start gas ionization, maximum energy per flash, maximum average power dissipation per tube, and usable lifetime of tube. These parameters are determined by the tube's physical construction: arc length, tube diameter, type of electrodes, and gas pressure.

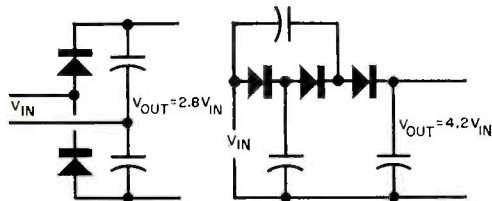

Fig. 2. To attain necessary high voltage, doubler and tripler circuits are used in the tube power supplies.

The amount of light energy released can be determined by knowing the potential energy stored in the capacitor. This can be found from the equation $E = \frac{1}{2}CV^2$, where E is the energy in joules or watt-seconds, C is the value of the capacitor in farads, and V is the voltage across the capacitor.

The total power dissipation of the flash tube is equal to the energy per flash times the number of flashes per second. However, the designer must be willing to trade off maximum energy per flash for the maximum number of flashes per second so that he does not exceed the power dissipation of the tube. If maximum ratings are exceeded, the shock waves in the gas could cause the tube to crack or shatter.

Energy Supplies. Between 300 and 600 volts dc are required to power the most common types of flash tubes. A voltage doubler (or tripler) such as that shown in Fig. 2 will serve the purpose well. Since the capacitor must discharge quickly, its internal resistance increases the flash duration and generates heat within the capacitor. Special flash-type capacitors are available, but conventional electrolytic capacitors may

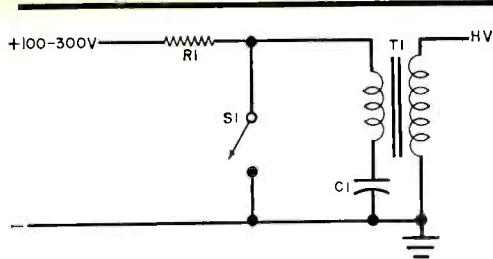

Fig. 3. When S1 is closed, C1 discharges through primary of transformer producing the high-voltage spike.

be used. (However, the latter require replacement since the heat eventually vaporizes some of the electrolyte.)

Like most light sources, the lifetime of a flash tube is limited. Each time the tube is flashed, ions bombard the cathode and cause some of the cathode material to be atomized and deposited on the inner surface of the tube. This deposited material forms a black area near the cathode; and, as the cathode element is used up, the black area grows. Eventually, the point is reached where the flash tube either does not fire or fires erratically. Depending on the tube's cathode structure, the operational life is between 5000 and 1,000,000 flashes. Of course, operating a flash tube below its maximum rating greatly increases its useful life.

Trigger Circuits. The basic trigger circuit is shown in Fig. 3. When switch S1 is open, the high-voltage dc charges capacitor C1

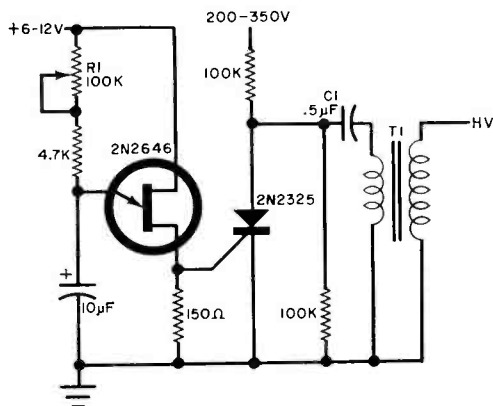

Fig. 4. Here, a UJT is used to control an SCR, which acts to discharge C1 through the primary of transformer.

through series resistor $R1$. When $S1$ is closed, the charge stored in $C1$ rapidly discharges through the primary of step-up transformer $T1$, generating a pulse on the secondary of 4000 to 6000 volts. An automatic pulser, using a UJT to trigger an SCR is shown in Fig. 4.

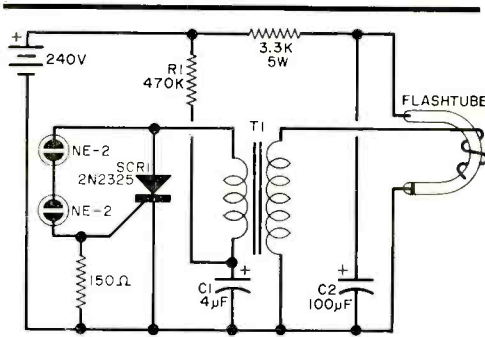

Fig. 5. In battery-operated flasher, two neon lamps flash over to turn on SCR. $C1$ and $R1$ set the firing rate.

The design of a portable strobe can be greatly simplified if a high-voltage battery is used instead of the line-operated supply. A #491 battery, rated at 240 volts, is used in the circuit shown in Fig. 5. This battery will last for several hours of flashing.

The triggering rate is determined by the time constant of $R1C1$. As the charge on $C1$ approaches 240 volts, the combined ionization voltage of the series-connected neon lamps is eventually reached so that they turn on, thus triggering $SCR1$. This

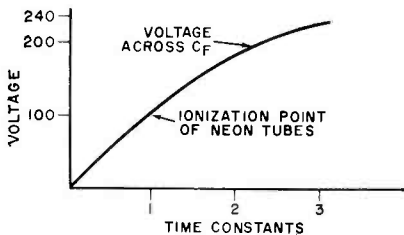

Fig. 6. Voltage across capacitor increases with time constant until the firing point of neon tubes is reached.

causes $C1$ to discharge rapidly through the primary of $T1$. The pulse on the secondary of $T1$ triggers the flash tube.

The energy input to the tube is $E = \frac{1}{2}CV^2$ or $\frac{1}{2}(100 \times 10^{-6})(240)^2 = 2.88$ joules. The

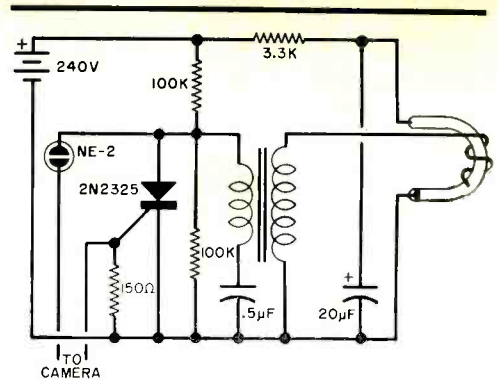

Fig. 7. Typical electronic flash for camera. Closing camera leads causes SCR to conduct, thus triggering tube.

time constant of $R1C1$ is 0.47×4 or 1.88 seconds. As shown in Fig. 6, after a period of about 1 time constant, the voltage on the neon lamps is sufficient to turn them on, thus firing the SCR.

A typical camera strobe circuit is shown in Fig. 7, while Fig. 8 illustrates an ignition timer lamp.

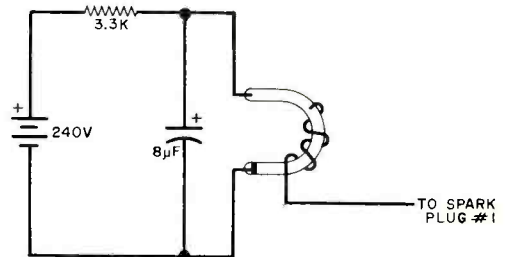

Fig. 8. In this simple engine timing light, the high-voltage pulse at the spark plug triggers the flash tube.

Caution. There is some medical evidence that exposure to strobe rates of from 6 to 10 flashes per second could cause an epileptic fit, even in a person without a previous history of epilepsy. Therefore, extreme caution must be used in building and operating strobes—not only by the builder but by any other observers as well.

From the electrical standpoint, caution must be used due to the high voltages involved in most strobe circuits. Be sure that all capacitors are fully discharged before making any circuit modifications or other changes in a piece of strobe gear. ♦

BY STEVEN E. MARGISON

Stage Lighting for the Amateur

CONTROLS 1500 WATTS PER CHANNEL
WITH PRESET STORAGE,
CROSS FADING, AND SUBGROUPING

WHETHER it's the graveyard scene in "Our Town" or "June Is Busting Out All Over" in "Carrousel," one of the main concerns of the amateur (community, off-off-Broadway, etc.) producer is the lighting effects. Fortunately for everyone, the days of the cumbersome, creaky rheostats are gone—replaced by the era of silicon controlled rectifiers, Triacs, and other semiconductor devices.

Many little theatre groups now use the General Electric Triac modules, which are available in capacities of 6, 10 or 15 amperes. As in all things, however, there are improvements and circuit variations that can be made to enhance the overall effect. Here are some of the modifications that can be made.

The circuit in Fig. 1 shows the basic wiring of the GE Triac assembly (except that *R2*, *D1*, and *D2* have been added). The added components prevent the "snap on" effect which usually occurs when the dimmer is first energized.

In Fig. 1, the usual potentiometer control has been removed from the circuit, and the circuit shown in Fig. 2 is connected to the terminals marked A and B. The use of the circuit in Fig. 2 provides a master control function and permits safe remote operation

since the controls are powered by low-voltage dc.

Master Control System. The heart of the control circuit is a photocell-lamp combination. When the lamp is illuminated, the resistance of the photocell goes down, and vice versa. Transistor *Q1* can handle up to 3 amperes so that it can control as many as 25 dimmers. Potentiometer *R4* is the master control while *R3* and *R6* are trimmers for initial setup. Switch *S1* is used to turn the control off and to select either independent or master control.

Potentiometer *R7* is the actual dimmer control, while *R8* and *R9* are trimmers. Potentiometers *R4* and *R7* are mounted on the front panel; other controls are within the cabinet. Transistor *Q2*, preset by *R1*, is used to set the voltage on the independent line to the same value as the voltage on the master line.

To insure long life, transformer *T1* and *RECT1* should be selected to give more power than required. For instance, a 10-dimmer system requires a 1-ampere transformer; but a 1.5-ampere unit is better. The current rating of the transformer (at 10 volts) can be found by multiplying the number of dimmers by 0.1.

Initial Adjustment. Adjustment is not critical, but it does require some patience to get the best results. Always adjust one trimmer at a time, and use a lamp load equal to about 60% of the dimmer's rated capacity. Use the following procedure:

1. Turn off all *SI*'s and set all controls to zero.

2. Set *R3* and *R6* for maximum resistance and *R4* for full intensity.

3. Connect the positive lead of a dc voltmeter to the emitter of *Q1* and negative lead to ground. Apply power.

4. Adjust *R3* to get a voltage indication of 5.5.

5. Set *R4* to minimum and adjust *R6* to get a 2.5-volt indication. Repeat steps 4 and 5 until *R4* varies the voltage between 2.5 and 5.5.

6. Set *R4* for full intensity. Set *R9* for maximum resistance and *R8* at 50%. Connect load to dimmer under adjustment and *SI* to MASTER position.

7. Set *R7* to maximum and adjust *R9* until the lamp no longer increases in intensity.

8. Set *R7* slightly off zero and adjust *R8* until the dimmer just begins to hum. Leave this setting for about 30 seconds. If the dimmer drifts either up or down, readjust *R8* until the humming is sustained, but as low as possible.

9. Repeat steps 7 and 8 for each of the other dimmers. Make sure that dimmers not being adjusted are off.

10. Set *R4* for maximum and any other dimmer to maximum (*SI* on MASTER) and read the voltage as in step 3. Move the positive voltmeter lead to the emitter of *Q2* and adjust *R1* for the same reading. Be sure to have one dimmer set to INDEPENDENT when making this adjustment.

Readjustments should not be necessary unless parts are replaced. However, if the unit receives a great deal of use, readjustment after the first 100 hours may be necessary to correct for component aging. On rare occasions, *R8* may not have enough resistance to bring the blackout point of the dimmer below 1 or 2 on the knob scale. If this happens, insert a 150-ohm, 1-watt resistor in series with *R8* and proceed with the adjustment. Since *PC1* never operates above 50% of its rated voltage, it should last many years, but a few spares should be kept on hand. The *R7* controls may get slightly warm during use, but this is normal. ♦

SWITCHING LOGIC QUIZ ANSWERS

(Quiz is on page 52)

- 1—E In this series AND circuit, all of the switches must be in the "yes" or closed positions before the missile can be fired (lamp lights).
- 2—I In this inclusive OR parallel circuit, each branch provides an indication of the condition of one of the doors (switches).
- 3—B In this exclusive OR parallel circuit, only one lamp or the other, but not both, can be on at any one time.
- 4—G In this inclusive OR parallel circuit, the operator of either switch, or both operators simultaneously, can turn on the motor.
- 5—C Closing either switch removes the canopy first (lights the same lamp), and closing the remaining switch then ejects the pilot (lights the other lamp).
- 6—H The first switch to be closed causes its corresponding lamp to be energized at least momentarily and prevents the remaining lamp from operating by opening its series switch. In a draw (simultaneous closing of both switches), neither lamp can operate.
- 7—F Any two of the three switches, or all three can operate the lamp, but any single switch cannot.
- 8—A Closing either switch can turn on the lamp, and the remaining switch can then turn it off. Control of the lamp can take place in any sequence from either direction.
- 9—J In this "odd parity" circuit, any one or all three of the switches can be used to operate the lamp, but no combination of two switches can.
- 10—D In identical parallel branches, one circuit contains the amplifier and the other the indicator lamp.

Low-Cost Electronic Thermometer

INDICATES LOCAL OR REMOTE TEMPERATURES
FROM FREEZING TO 302°F

BY JAMES R. SQUIRES

ELECTRONIC thermometers have proven to be not only more accurate than the old-fashioned mercury types; they are also far more versatile. They can have more than one sensor and the sensors can be mounted almost anywhere within reason with a cable connected to the readout.

A circuit for a good, low-cost electronic thermometer is shown below. The unit has both local and remote sensing and can operate between 32° and 302°F in two ranges.

Thermistors are used as the temperature sensing elements so keep in mind that these devices have a thermal hysteresis effect. That is, if you measure the ambient temperature, then immerse the thermistor in boiling water, after cooling, it will indicate slightly higher than the ambient.

The two scales on the thermometer (X1 and X10) are equivalent to currents of 1 mA and 10 mA through the meter, as determined by the setting of S2. The X1 range is roughly equivalent to a temperature range of 0° to 50°C (32° to 122°F), while the X10 range covers 0° to 150°C (32° to 302°F).

In the circuit, most of the components are in series. The value of R3 is chosen so that the 1-mA meter will indicate 10 mA. For the meter used in the prototype, a value of 17.8 ohms was required for R3. Odd values of resistance for R3 can be made by paralleling higher values.

Any method of construction can be used (perf board, point-to-point wiring, etc.). Local thermistor TDR1 can be mounted so that it just protrudes (about 1/8") from the chassis. The remote sensor is attached to the end of a length of two-conductor cable, with P1 on the other end. The remote sensor is not necessary, of course, if you don't want to use it.

With S2 in the X1 position, plug the remote sensor into J1, depress S1 and adjust R2 until the meter indicates about half scale. Remove the remote sensor, and adjust R1 for a center scale indication with the local sensor. Hold the local sensor between

your thumb and forefinger and note that the meter indicates upscale. Do the same with the remote sensor. The two changes should be similar in value and any deviation will be due to slightly different resistance-temperature curves of the two thermistors.

The meter scale is calibrated by immersing the thermistors in ice water (32°F) and adjusting the appropriate potentiometer for the proper indication on the meter. Use boiling water (212°F) for the upper mark. To calibrate the remainder of the scale, keep the two thermistors in the hot water, along with a good mercury thermometer. Stir the water, and mark the other points on the scale as the water cools. Switch S1 should be operated only when a temperature measurement is to be made. This conserves the battery and minimizes any self-heating of the thermistors due to current flow. ♦

Resistance of either thermistor determines current flow through the meter.

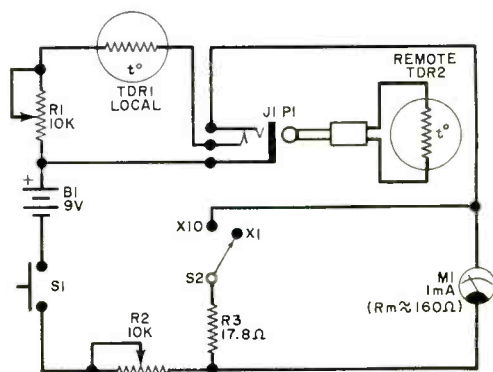

PARTS LIST

- B1—9-volt battery
- J1—Miniature phone jack, normally closed
- M1—1-mA meter
- P1—Miniature phone plug to fit J1
- R1, R2—10,000-ohm potentiometer
- R3—See text
- S1—Normally open pushbutton switch
- S2—Spdt switch
- TDR1, TDR2—Thermistor (Fenwall GB41P2)
- Misc.—Suitable chassis, two-conductor cable, mounting hardware, etc.

Fuses For Electronics

Types of fuses and where they are used.
How to select the right fuse for your circuit.

BY BUSSMAN MFG. DIVISION
McGraw-Edison Co.

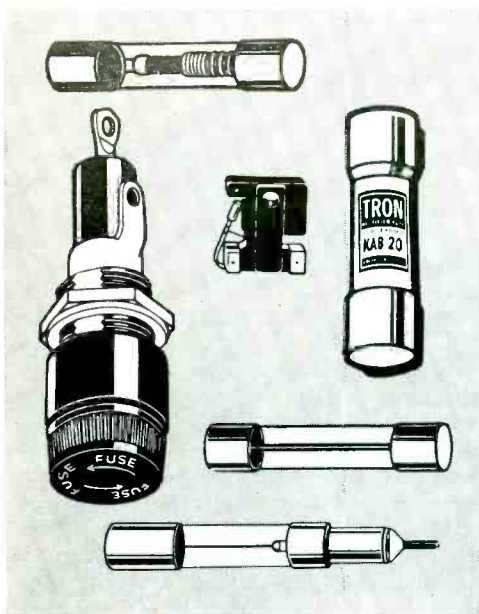

FROM a strictly mechanical point of view, fuses may be placed into two general categories. The first category is the "clip-in" fuse, which must be placed into some kind of fuseholder or a pair of clips to perform its normal function. The other category includes those fuses that have leads soldered to the end-caps and are generally referred to as "pigtail" fuses. Pigtail fuses can be soldered directly into an electronic circuit or printed circuit board, without a fuse-holding device.

Time-Delay Fuses. One of the most popular fuses in use is the so-called "time delay" fuse (sometimes referred to as "slow-blow"). This is a general-purpose fuse with the abil-

ity to pass harmless transient currents and yet blow with sustained overloads or short circuits. It is usually constructed with a solder-alloy heat sink that can dissipate the heat generated by momentary transient currents and is spring operated when the current last long enough to cause the solder alloy to melt. This type of fuse is sensitive to ambient temperature and must be derated when applied in an extremely warm location in order to carry the load current.

Fast-Acting Fuses. Another very popular fuse is the "fast-acting" (or "normal blow") fuse. This is usually applied in circuits where there are no transient or surge currents to hamper its operation. This fuse generally has a single-element, wire link construction, without any heat sinks to absorb momentary overcurrents. Fast-acting fuses thus blow very quickly on overloads and must be applied very carefully with regard to the amount of full load current. Quite frequently these fuses are used to provide short-circuit protection only and, therefore, can be sized at approximately 250-300% of the full load current. Ambient temperature has very little effect on the performance of these fuses.

"Very fast-acting" fuses are becoming increasingly popular for use in circuits that require extremely fast operation to protect critical components, such as meters or semiconductor rectifiers. Electronic equipment that has very little ability to withstand overcurrents requires this kind of protection. This fuse is constructed similarly to the "fast-acting" fuse except that the link is usually surrounded by a special filler material and the fuse body is made of ceramic or phenolic material. The very fast-acting

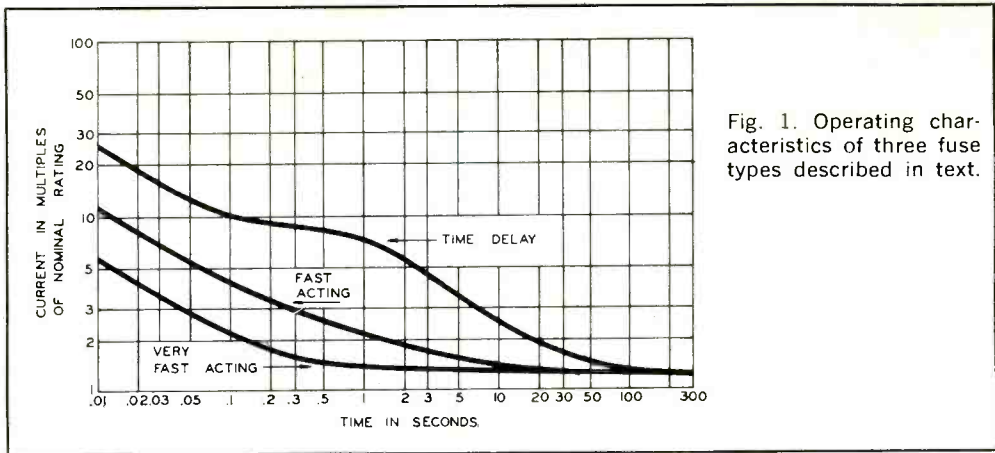

Fig. 1. Operating characteristics of three fuse types described in text.

fuse is essentially insensitive to ambient temperature.

Comparing Fuse Characteristics. Figure 1 shows the operating characteristics of the three types of fuses mentioned above. Consider that all three types carry a one-ampere full load rating but, as can be observed, the blowing time for each is considerably different for a given overload current. For example, when the over-current is 200% (2 amperes), the time-delay fuse takes 18 seconds to blow while the fast-acting fuse opens in approximately 1.4 seconds. A 2-ampere current, through a very fast-acting one-ampere fuse, causes the fuse to blow in 0.13 second.

It can be seen from the above that a knowledge of the circuit in which a fuse is applied is important. Will the circuit develop transient currents? How fast must the fuse operate when a short occurs? These and many other questions should be considered when initial circuit design is undertaken.

There are many fuses today which have been developed to meet special needs. Usually, the fuse dimensions or physical construction have been altered so that a special mounting means can be employed or so that an indicator can be built into the fuse to signal when it has blown.

These fuses have particular applications and are not considered to be general-purpose fuses. The fuses covered here are general-purpose types readily available on the market.

Criteria for Selecting Fuses. There are many considerations that should be given to fuse selection. Voltage and current ratings

are the two most popular (often the only) parameters that are investigated when selecting a fuse. Other criteria that must be examined include short-circuit current rating, fuse characteristics, application temperature, fuseholders and mechanical dimensions of the fuse.

Voltage Rating. Select a fuse with a voltage rating equal to or greater than the voltage of the circuit. The standard fuse voltage ratings which are available for electronic fuses are 32, 125, and 250 volts. Keep in mind that a fuse with a higher voltage rating can always be used on a lower voltage circuit. For example: a 250-volt fuse can be used in a 125-volt circuit. The reverse procedure, however, can be very dangerous and *should always be avoided*. All 125- and 250-volt fuses have the voltage rating stamped on the end caps. If there is no voltage rating stamped on the cap, then it should be considered to be a 32-volt fuse unless reference to its symbol can be made elsewhere.

Automotive circuits use 32-volt fuses, while 125-volt fuses are often applied in the

Time-Delay Fuses		Fast-Acting or Very Fast-Acting Fuses	
Ambient Temperature °C	% Rated Current	Ambient Temperature °C	% Rated Current
40	95	40	98
60	85	60	95
80	75	80	92

input circuit of power supplies. Fuses rated at 250 volts, for example, may be applied in the B+ circuit of a TV receiver.

Current Rating. Once the voltage rating is determined, a fuse with an ampere rating greater than the expected circuit full load current should be selected. The generally accepted procedure is to choose a rating about 25% greater than the full-load current of the circuit, because fuses are built to carry their rated current in open air at room ambient; whereas they are usually applied in some type of enclosure and the enclosure temperature is often higher than room ambient.

An important point to remember is that the voltage rating described above does not in any way affect the *ampere* rating. A one-ampere, 125-volt fuse and a one-ampere 250-volt fuses have identical current-carrying capacities. Only the ability of the fuse to open a short-circuit current is affected by its voltage rating.

Another frequent mistake made in selecting the ampere rating of a fuse concerns the current waveshape. Many electronic circuits

have unusual waveshapes, such as those in rectifier circuits. The object of a rectifier circuit is to produce a dc voltage from an ac source; thus, the normal thought would be to select a fuse for the dc circuit on the basis of the dc current that is flowing. This would be acceptable if the rectifier wave were perfect; however, we know that in practical circuits, we do not need a perfect dc current and it is difficult to produce. Since the dc wave is not perfect, there is an rms value of that wave which, in many cases, exceeds the dc current value. Consequently, the fuse must be selected for the rms value. An example of this is the case of a simple half-wave rectifier with a one-ampere dc output and an rms value of the wave shape of 1.57 amperes.

The general rule to follow is to select a current rating based on the rms value of the current. Only when the rms value equals the dc value is it acceptable to pick the fuse size based on dc current.

Short-Circuit Current Rating. Should a severe short circuit occur in an electronic circuit, it is mandatory from a safety stand-

TABLE II—ELECTRONIC FUSE SELECTION CHART

Buss Catalog Symbol	Ampere Range Available	Voltage Rating	Characteristics	Dimensions Inches	Typical Application
AGX	1/500 to 2	250 or less	Fast-Acting	1/4 x 1	Meters,
AGC*	1/500 to 3 4 to 30	250 or less 32 or less	Fast-Acting " "	1/4 x 1 1/4 "	Metering
ABC	1/4 to 20 25 to 30	250 or less 125 or less	" " " "	" "	Circuits, Instruments
MDL	1/100 to 1** 1-2/10 to 2-8/10** 3 to 30	250 or less 125 or less 32 or less	Time-Delay " " " "	" " "	Power supplies,
MDX	1 1/4 to 2 3 to 7**	250 or less 125 or less	" " " "	" "	B+ Circuits,
MDA	1/100 to 20 25 to 30	250 or less 125 or less	" " " "	" "	Moto* & transformer
FNM	1/10 to 10 12 to 15 20 to 30	250 or less 125 or less 32 or less	" " " " " "	13/32 x 1 1/2 " "	Circuits
BAF	1 to 15 20 to 30	250 or less 125 or less	Fast-Acting " "	" "	Meters, Instruments, Etc.
BAN	1 to 30	250 or less	" "	"	
GBB	1 to 10	130 or less	Very Fast-Acting	1/4 x 1 1/4	Semi-conductor circuits
KAW	1/2 to 30	130 or less	" " "	13/32 x 1 1/2	

*Pigtail Type would be GJV.
**Pigtail Type would be MDV.

point that the fuse clear the fault without rupturing. It is for this reason that fuses are given a *short-circuit* rating that goes along with their *voltage* rating and must never be exceeded.

A normal 125-volt circuit load current could be two amperes full load but, when a short occurs in the circuit wiring, the current might increase to 1000 or 2000 amperes. The fuse, in turn, must be able to open the circuit safely under this condition. Generally, short-circuit currents with magnitudes in the thousands of amperes are the exception rather than the rule in the case of low-energy electronic equipment. For most electronic devices, if a fuse of the proper voltage rating is selected, it will have an adequate short-circuit rating.

Temperature. How many times have you checked a troublesome circuit and found that the current was less than the fuse rating? Did you happen to check the temperature to which the fuse was being subjected as well? The effect of ambient temperature on fuse performance can be appreciable, especially where time-delay fuses are involved.

Table I shows the effect of temperature on the current-carrying ability of the various types of fuses previously discussed. If a time-delay fuse were to be selected for operation in an 80°C ambient and the circuit current were 375 milliamperes, then the ampere rating of the fuse should be at least $\frac{1}{2}$ ampere. If the same temperature and current conditions were to be imposed on a fast-acting fuse, the fuse rating should be at least $\frac{4}{10}$ ampere.

There are many applications where operating temperatures can be considerably higher than room temperature, especially in circuits where the components are enclosed by a cabinet or case, as in radios, TV's, power supplies, and amplifiers.

Time-Current Characteristic. Once the voltage and current ratings are decided upon, a major consideration is the time-current characteristic of the fuse. The circuit determines to a great extent whether a time-delay, fast-acting, or very fast-acting fuse is the correct choice. If harmless transient currents might occur, a time-delay fuse would be needed. If the circuit is a bridge rectifier, a very fast-acting fuse would be recommended.

Dimensions. Fuse dimensions are usually considered in initial design and can be critical when space is a factor. The most

common electronic fuse dimensions are $\frac{1}{4}$ " x 1", $\frac{1}{4}$ " x $1\frac{1}{4}$ ", and $1\frac{3}{32}$ " x $1\frac{1}{2}$ ". A wide variety of mountings with a number of special features (if desired) are made for these fuse sizes.

Fuseholders. The most popular fuseholder for mounting on a chassis inside an enclosure is the ordinary Bakelite (phenolic) fuseblock which has fuse clips and wire terminals attached. For mounting the fuse in an enclosure or panel, the "panel-mounted fuseholder" is extensively used. This fuseholder has the advantage of being accessible from outside the enclosure.

Panel-mounted fuseholders with lamps to indicate a blown fuse are also available. These are particularly helpful where many fuses are used in the same area.

The pigtail fuse is, of course, the least expensive from a fuseholder point of view. However, a blown pigtail fuse is more difficult to remove from the circuit.

Table II is a quick reference chart of fuses giving their voltage and current ratings, operating characteristics, dimensions, and some of their more typical applications. ♦



"Now, exactly what do they mean by a 'Female Connection'?"

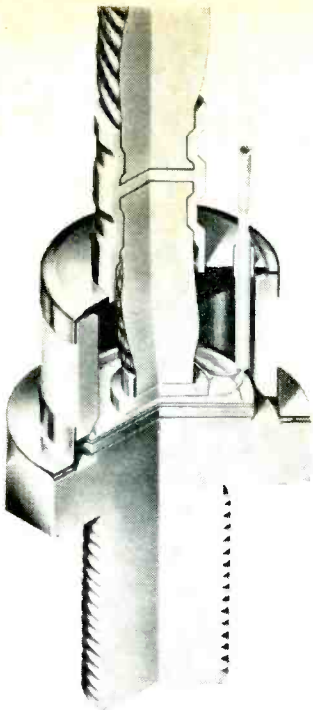

The HOW and WHY of the SCR

PRINCIPLES OF OPERATION AND
APPLICATIONS OF THE
SILICON CONTROLLED RECTIFIER

BY JOSEPH H. WUJEK

WHEN the semiconductor industry began to expand in the 1950's, transistors and solid-state diodes and rectifiers quickly replaced their vacuum-tube counterparts in many applications. Then as now, the *complete* transition from tubes to semiconductors was not possible because of the limitations of the latter. In 1957, however, an important step toward the goal of total replacement by semiconductors was taken when General Electric Co. introduced the silicon controlled rectifier, or SCR.

Briefly, the thyatron permits the control of power in switching applications with only a small energy loss in the control circuit. By applying a signal to a control grid, the thyatron is made to conduct between a pair of electrodes (anode and cathode) and remains conducting with no further excitation at the control grid. In fact, in normal operation, the grid ceases to control the thyatron once conduction begins. To stop conduction, the anode must go from a high positive potential to near zero as in the phase reversal of a 60-Hz power line.

The SCR performs in an analogous manner; and, in addition to the inherent improvements in reliability and simplicity afforded by semiconductors, some of the kindred devices of the SCR can function as turn-on/off systems to control bidirectional

currents, an impossible task for the thyatron and other vacuum tubes.

How It Works. The operation of the SCR is perhaps best understood by examining the device's pnpn junction, shown in equivalent form by the two transistors in Fig. 1. Assume that the control (gate) electrode is connected so that its voltage is the same as, or slightly negative with respect to, the voltage on the cathode. Transistor Q_2 is cut off and only leakage current flows in the circuit. If the gate voltage is made positive with respect to ground, the base-emitter junction of Q_2 becomes forward biased and Q_2 begins to conduct. Moreover, Q_1 also becomes forward biased and conducts. As Q_1 starts conducting, its collector current aids in turning on Q_2 , just as collector current from Q_2 assists in turning on Q_1 .

This mutual aid is a form of regeneration, or positive feedback. A point is reached at which the switching action "runs away" from the control input and becomes self-sustaining. In regeneration, Q_1 and Q_2 are operated at saturation, and the voltage drop from the collector of Q_2 to ground is the sum of the 0.7-volt base-emitter drop of Q_1 and the 0.2-volt collector-emitter drop of Q_2 . (The voltages are for silicon transistors only.) Thus, the switch exhibits a low voltage drop and requires no control input power to sustain conduction.

To turn off the circuit, the current in

Cutaway view of an SCR, shown above, courtesy of International Rectifier Corp.

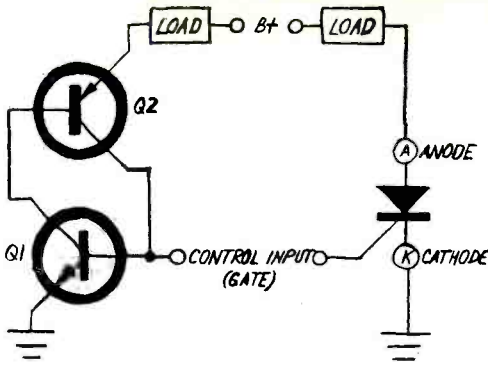

Fig. 1. The transistor circuit at left is equivalent to actual SCR at right.

the transistor bases must be internally reduced to a level at which the current gain of Q1 and Q2 is insufficient to supply the required currents. Since it is not practical to get into the transistor junctions, the current in the emitter-collector branch is reduced. This is accomplished automatically if the supply voltage is derived from an ac

source. (The SCR is primarily an ac device, although in dc applications it will serve as a "latch," or memory switch, and remain conducting until the anode current is reduced or interrupted.)

The point at which the anode current of an SCR is sufficient to keep the device conducting is called the holding current. The peak voltage (anode positive with respect to cathode) at which the SCR does not undergo breakdown for given conditions of bias between the gate and cathode is the peak forward blocking voltage; this is usually specified with the gate connected to the cathode through a low resistance.

The peak reverse voltage with the anode negative with respect to the cathode is also specified with the gate connected to the cathode through a low resistance.

Leakage currents increase with temperature increases and roughly double for every 10° C rise. In Fig. 1, the transistors cannot distinguish between currents caused by leakage or from a triggering pulse. Hence, care must be exercised in determining the tem-

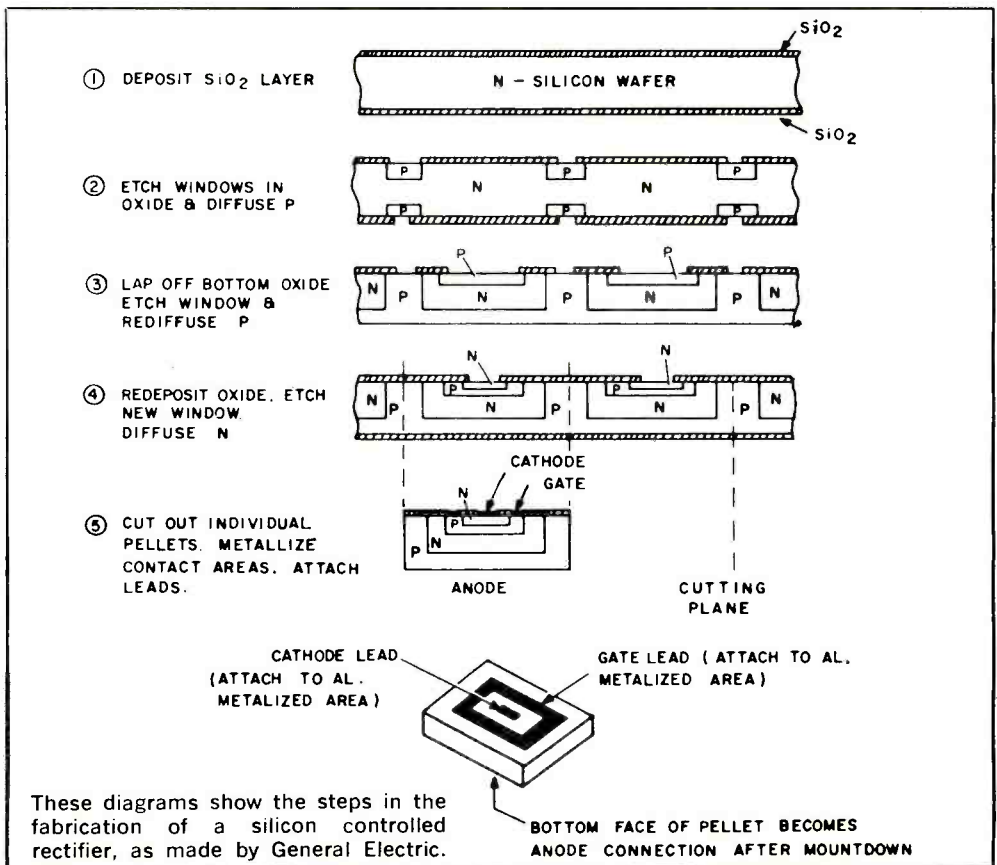

These diagrams show the steps in the fabrication of a silicon controlled rectifier, as made by General Electric.

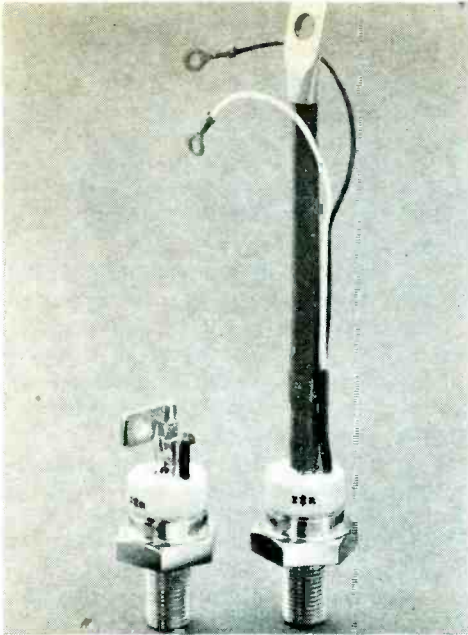

Typical SCR packages for International Rectifier Corp. units, which have current ratings from 50 to 100 amps.

perature environment and external circuit conditions to prevent thermal turn-on.

Other unwanted turn-on mechanisms are the device's built-in junction capacitances which provide paths for current when the anode-cathode voltage is changing. Current through a capacitor is proportional to the voltage rate of change with time. A fast changing voltage can introduce sufficient current to trigger the SCR. This parameter is specified as the "critical time rise" and usually is given in $V/\mu s$.

The forward and reverse breakdown voltages have already been mentioned. Unless some means of externally limiting the current is used, these breakdown voltages will destroy an SCR. Except where severe transient voltages are present, the breakdown voltages will present no problems if the specified ratings are not exceeded.

Parameters & Characteristics. If the SCR is to be intelligently employed, it is essential that the user be familiar with the device's various parameters and characteristics. These specifications are given in the manufacturer's data sheets. In choosing an SCR, first check the maximum allowable ratings, including the maximum current handling capacity

which may be stated as average current or rms current or both. To use either specification, the current waveform through the SCR must be known.

The peak surge current, usually specified for a 60-Hz half-wave excursion, is the current the SCR can handle on a low duty-cycle basis, permitting the SCR to cool off between surges. These currents can be as much as 10 times greater than the rms current. Such ratings are useful when the SCR is employed in "crowbar" operation to discharge a capacitor bank.

Power ratings for the entire SCR, as well as for the gate circuit are often stated. These ratings depend on ambient and case temperatures. Maximum voltage and current in the gate circuit are sometimes specified.

Finally, temperature limits for storage and operation are given. The low-temperature limit is dictated primarily by the differences in thermal expansion between the chip and surrounding materials. The upper limit is set by considerations of damage to the crystal substrate.

When using the SCR as part of a circuit, the peak reverse and peak forward blocking figures specified are the currents that flow at given sets of bias conditions when the SCR is not conducting. These currents can be viewed as leakage and must be stated for a given temperature or temperature range. An SCR's leakage is on the order of 0.1 percent of its forward current. Hence, an SCR rated at 100 amperes forward current cannot be used to control a 50-mA load since the leakage current will be about the same as the current being controlled.

The gate trigger voltage and current are specified for given anode-to-cathode voltages and gate-to-cathode resistances. They are temperature-dependent and often graphically plotted for SCR's not to trigger. The minimum values for firing at given temperatures also appear on the plots. This information specifies the voltage and current required for triggering the SCR, as well as the bias conditions to be maintained in the blocking state.

The peak on voltage is the drop between the anode and cathode for a given load current and temperature. It is generally in the range of 1 to 2 volts. The holding current specifies the level to maintain to prevent the SCR from turning off.

The turn-on and turn-off times are stated for SCR's intended for high-speed switching. The operating conditions must be specified

if these parameters are to be useful. Some fast SCR's have low-current switching times in tens of nanoseconds.

Design Considerations. Once the SCR is inserted between the power source and the load, a means must be provided for triggering it. When used to control ac, one of the simplest ways of triggering is to use the phase control method. The negative alternation takes care of the turn-off. Then all that is necessary to drive the SCR into conduction is application of a pulse to the gate when the anode is positive with respect to the cathode. A phase control triggering scheme in its simplest form is shown in Fig. 2. By choosing the appropriate resistance and capacitance values for the network, the time, or phase, relationship of the gate with respect to the anode-to-cathode voltage can be determined. Household lamp dimmers often are designed this way and may employ two SCR's back-to-back to control both ac alternations.

Because the phase between the gate and anode-to-cathode voltages determines the time the SCR conducts, the average current

through the SCR is dependent upon this relationship. The firing angle can also be derived from an isolated source like an error signal in a feedback system. When more current is needed, the error signal "tells" the trigger circuit to advance the gate voltage to turn on the SCR earlier in the cycle. This results in an increase in average current flow since the SCR conducts for a longer period of time.

A transformer provides good isolation between the trigger circuit and the load. The control signal might be a dc voltage, such as the on/off conditions of a switch or logic circuit. A simple oscillator can be used to furnish the gate pulses, controlled by a simple AND gate.

If moderate or high currents are to be controlled, the fast turn-on of the SCR can generate high-frequency noise that will be radiated into space and passed along ac power lines. These noise spikes may interfere with radio and TV reception and cause malfunctions in interference-sensitive equipment. Filters can be used in the power line to reduce this noise, but a different means exists for drastically reducing or eliminating the noise.

If the time at which the anode voltage crosses through zero and begins its swing toward positive (with respect to the cathode) can be sensed, a trigger pulse can be provided at that instant. The SCR then starts conducting early in the positive alternation and the current (in a resistive load) follows the sine wave of voltage rather than suddenly jumping from leakage level to a high forward level (see Fig. 2). Several manufacturers offer IC's designed specifically as zero-voltage detectors to use in this application.

Applications. Apart from the familiar lamp dimmer switch and speed controls for certain types of ac motors, the SCR is used in the home to provide continuous (as opposed to stepped) control of heat in electric kitchen ranges. In industry, the SCR is used to control power in battery chargers, power supplies, and machine tools. Welders, power regulators, and temperature control systems have been designed using the SCR as a power control element. Among the most popular of automotive electronic ignition systems available is the SCR-fired system and its variations. And new applications for the SCR are continuously being discovered. ♦

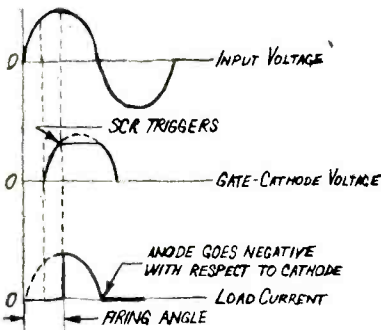
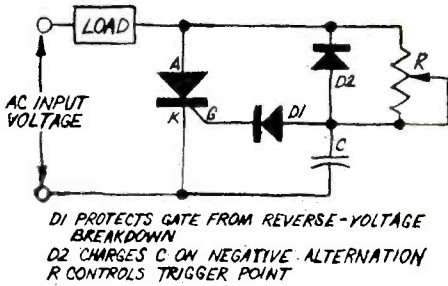

Fig. 2. Schematic of a typical pulse triggering circuit to turn on SCR. Waveforms below show voltages and current and indicate the firing angle.

BUILD THE MONODIGICHRON

This unique electronic clock uses only a one-digit readout and displays hours and minutes in sequential form.

BY MICHAEL S. ROBBINS

THE Monodigichron is a true electronic digital clock featuring sequential display of tens of hours, hours, tens of minutes and minutes on one seven-segment readout device. Instead of displaying all four digits continuously in a static presentation, the Monodigichron dynamically flashes the hours and minutes in sequence at a rate of about fifteen times per minute.

The circuit uses the latest LSI-MOS integrated circuit for positive synchronization to the 60-Hz power line frequency. Two pushbuttons (fast and slow) are provided for initial time setting.

The large, bright, incandescent readout tube allows the Monodigichron to be read in total darkness as well as in brightly lit rooms. The display is all electronic and therefore completely silent. Because the readout is a bright filamentary type, any color filter may be used.

Power for the clock is supplied by a molded, plug-in transformer which is U. L. approved.

Circuit Design. A block diagram of the clock circuit is shown in Fig. 1, while the schematic is in Fig. 2. As in most ac digital clocks, the time base is the 60-Hz power-line frequency which is applied to a shaping circuit (*D10*, *D11*, *R9*, *R10*, and *C2*) for squaring and removal of transients. An array of flip-flops within *IC2* counts the 60-Hz input and provides one output pulse for every 60 input pulses (1 Hz). A binary coded decimal counter (BCD) totals the 1-Hz pulses and provides four output lines for display of the seconds count. (Though the seconds are not displayed in the clock described here, they are counted in the IC.) A fifth line provides one pulse every 10 seconds for the tens-of-seconds BCD count-

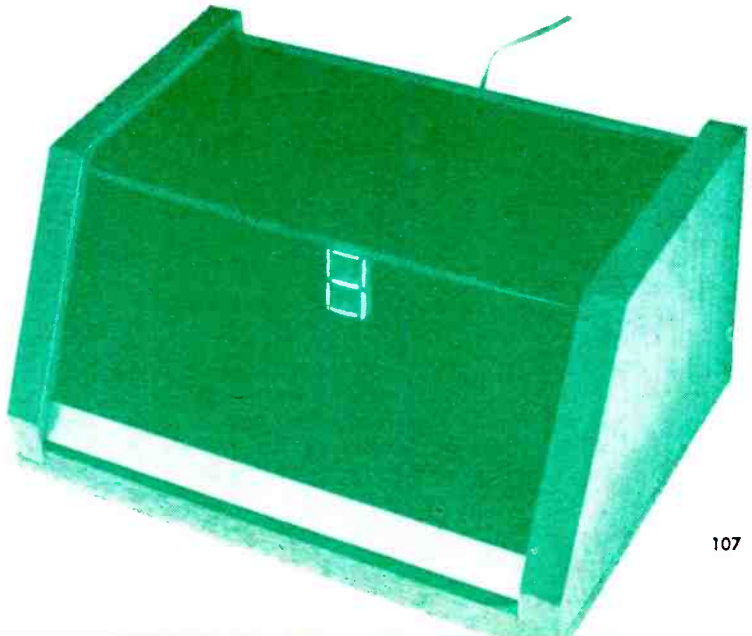

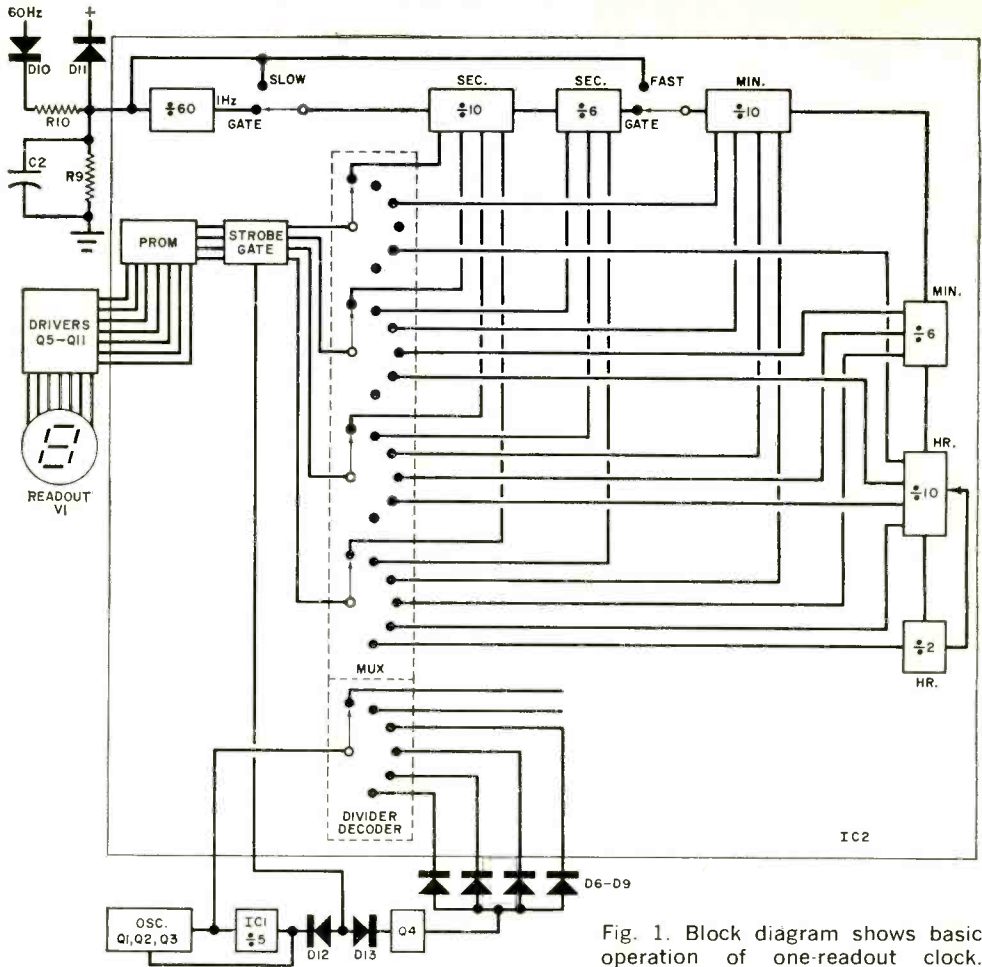

Fig. 1. Block diagram shows basic operation of one-readout clock.

er. An output and reset are incorporated to return these counters to zero on the next pulse after counting to 59 seconds. This output line also provides a one-pulse-per-minute signal for the minutes counter.

A third BCD counter counts and decodes the minutes and provides a one-pulse-per-ten-minutes output for the fourth counter. The tens-of-minutes counter provides an output pulse (one per hour) and resets on the next pulse after counting to 59 minutes.

The one-per-hour pulse is applied to a fifth BCD counter for counting and decoding. The output of this counter operates a flip-flop for the tens-of-hours count. Gating is built into these last two counters so that they will reset to one o'clock after twelve. High order zero blanking is incorporated to display 1:00 instead of 01:00.

Fig. 2. Most of the circuit is contained in the IC's and 7 driver units.

PARTS LIST

- C1—1- μ F, 15-volt electrolytic capacitor (low-leakage type)
- C2, C4—0.01- μ F, 16-volt disc ceramic capacitor
- C3—2000- μ F, 15-volt electrolytic capacitor
- D1—5.1-volt, 1-watt zener diode
- D2-D5, D14—Rectifier diode (1N4001 or similar)
- D6-D13—Switching diode (1N914 or similar)
- IC1—7490 TTL decade counter (Use National or Signetics only)
- IC2—Digital clock IC (National Semiconductor MM5314N)
- Q1, Q5-Q11—Npn transistor (MPS5172 or similar)
- Q2—JFET (MPF102)

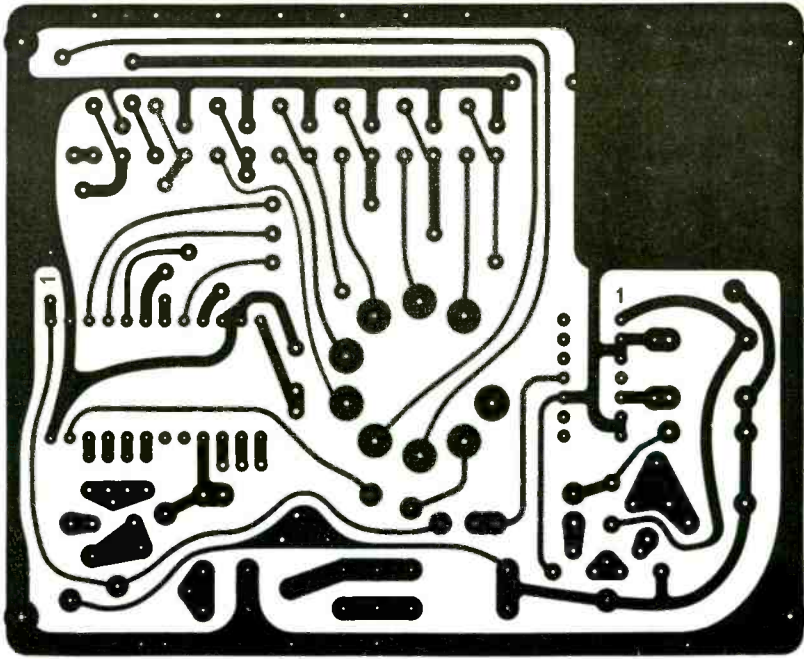
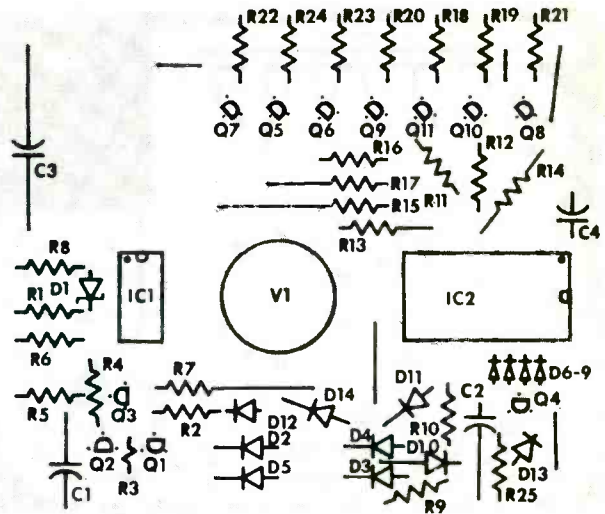

Fig. 3. The actual-size foil pattern above can be used to make a printed circuit board with parts placed as at right.



"Hurry-up" logic is built into the circuit to speed up the counting process when it is necessary to set the time. An externally operated switch (*S2*) bypasses the first divide-by-60 divider, increasing the count speed by a factor of 60. Another switch (*S1*) bypasses the first three dividers, increasing the count speed by a factor of 3600. These two switches are used to set the clock.

Since only one digit is displayed at a time, some means is required to sequentially switch the hours and minutes lines to

the display tube. This is accomplished by feeding the count outputs of all six counters to an internal output multiplexer (MUX). The MUX is essentially an electronic four-pole, six-position switch, which is continuously being operated through its six positions in the following order: seconds, tens of seconds, minutes, tens of minutes, hours, and tens of hours.

The speed and position of the MUX are controlled by its associated multiplex divider/decoder and an external oscillator

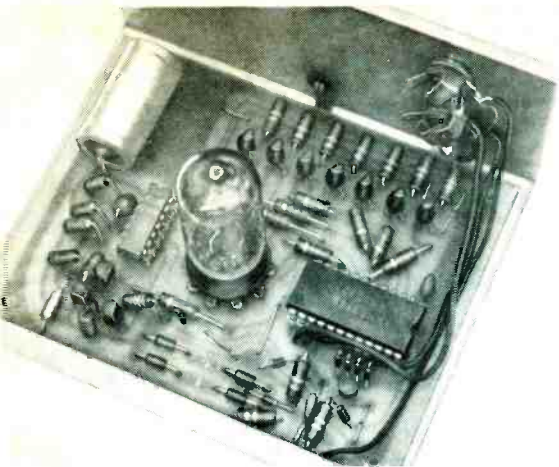

This photo shows how the parts were assembled in the author's prototype.

connected to its input. The BCD output of the MUX is fed to an on-off (output strobe) gate and then to a programmable read-only memory (PROM). The PROM is programmed during manufacture of the IC to translate the various BCD data into the seven-segment code required by the display tube.

The outputs of the MUX decoder (six but only four are used here) can be used to find out what position the MUX is in. Only one of the six is on at a time.

From the preceding description of the LSI-MOS integrated circuit, it will be noted that the multiplexer operates backwards from the desired sequential display order. Instead of going from tens of hours down to seconds, it sequences from seconds up to tens of hours. It also has the ability to display six digits, and we want only four. In this clock, the circuits external to the IC reverse the apparent direction of the MUX and eliminate the seconds and tens-of-seconds displays.

Unijunction transistor Q3 operates as a free-running relaxation oscillator providing pulses about 12 milliseconds apart to drive the multiplex divider/decoder. The period of this oscillator is determined by C1 and the parallel combination of R4 and R5. These pulses are also fed to IC1, operating as a divide-by-five circuit. On every fifth pulse, FET Q2 disconnects R4, leaving only R5 to charge capacitor C1. This increases the length of the interval between pulses 5 and 6 from about 12 milliseconds to about 750 milliseconds. The time periods or in-

tervals between oscillator pulses are the times when the BCD outputs of the MUX have information to display.

By gating the outputs through Q4 with the MUX output from the individual switches, the strobe gate blanks the seconds and tens-of-seconds displays. Additional gating (D12) is employed to blank the display during the short intervals between 5 and 10, 10 and 15, 15 and 20, etc.

Transistors Q5 to Q11 are display drivers for the individual incandescent filaments of the readout tube. The common end of all seven filaments (pin 2) is connected to the positive side of the power supply through D14.

The power supply consists of a plug-in power transformer, four silicon rectifier diodes (D2 through D5) in a bridge configuration and filter capacitor C3.

Construction. Although the Monodigichron can be built on a piece of perf board, a printed circuit greatly simplifies construction and reduces errors. A foil pattern is shown in Fig. 3, with a parts placement diagram. Normal precautions should be taken with the close conductor spacing on the PC board. A low-power soldering iron and fine solder should be used. If a large iron must be used, a small tip made out of #14 or #12 bare copper wire should be used. Observe the polarities of diodes, capacitors, and transistors.

Although IC2 is relatively rugged, it is recommended that no soldering be done directly to the IC pins or to the board after the IC has been installed. Molex pins are suggested to form sockets for the two IC's. Do not apply power to the board until the IC's have been installed.

The cabinet for the Monodigichron can be of any size and shape. The prototype cabinet is made of 3/4" walnut with 1/16" smoked grey plexiglass and brushed aluminium.

Operation. A final check should be made of the circuit and construction before plugging the transformer into an ac outlet. If everything is OK, plug in the transformer. The clock will immediately start doing strange things. Ignore them. Depress the fast set button (S1) and hold it for a full minute. Release the button and observe the display for a few minutes. Depress S1 and S2 one at a time for short periods to get a feel for their operation. Then use them to set the clock and let it run. ♦

AUTOMATIC AMPLIFIER SWITCH

CONVENIENT ACCESSORY FOR YOUR AUDIO SYSTEM

BY TOMMY N. TYLER

IF YOU have put together a hi-fi system using separate components, the chances are that you may already have been bugged by the nuisance of having to switch on the main amplifier each time you want to operate the turntable, the tape recorder, or the FM tuner (or whatever you have). Also, if you are as absent-minded as most of us, you have probably forgotten more than once to switch off the amplifier after the last record—finding the amplifier still on a day or two later.

Here is a simple device you can add to your hi-fi system to control the power to the main amplifier automatically whenever one of the “front end” components (such as the turntable) is switched on or off. The automatic amplifier switch, whose schematic is shown in the diagram, can be built in one evening from a handful of components. The cost should be only about \$7.

Circuit Operation. Diodes *D1* through *D4* are connected in series with sockets *SO1* through *SO4* to the ac line. A load connected to either of these sockets will cause a voltage drop across *D1* and *D2* or *D3* and *D4*, depending on the instantaneous polarity of the power line. This voltage is applied through *R1* to the gate of triac *Q1*, causing full line voltage to be applied to controlled socket *SO5* where the main amplifier is connected.

The circuit operates reliably for any load of 5 watts or more connected to any one of sockets *SO1* through *SO4*. With a smaller load, the limited triggering current available to *Q1* will retard its firing angle so that full power is not delivered to *SO5*.

Note that any suppression capacitors larger than about 0.01 microfarad installed across the power switches of equipment plugged into the controlling sockets may have to be removed if they supply enough reactive current to trigger *Q1*. Such capacitors are sometimes found in turntables to suppress the noise generated when the motor is switched off; but they are not indispensable.

The effect of reactive current can also

be minimized by using a triac that requires relatively high gate current for triggering. To find out easily whether or not you will have a problem with reactive current, plug the turntable or other device into *SO1* and attach a 40-to-100-watt lamp to *SO5*. If the lamp glows when the turntable is switched off, check for suppressors across the power switch.

Putting fuses in the circuit is optional. An overload or short circuit applied to *SO1* through *SO4* could ruin one or more of the diodes; but neither *Q1* nor the load connected to *SO5* would be harmed. Conversely, an overload at *SO5* would damage *Q1*; but none of the diodes nor the units connected to the input sockets would be affected.

Component Selection. Diodes *D1* through *D4* are power rectifiers with sufficient current ratings to carry the maximum current of all the controlling devices connected to *SO1* through *SO4* simultaneously, in case

Simple circuit has 4 diodes and triac.

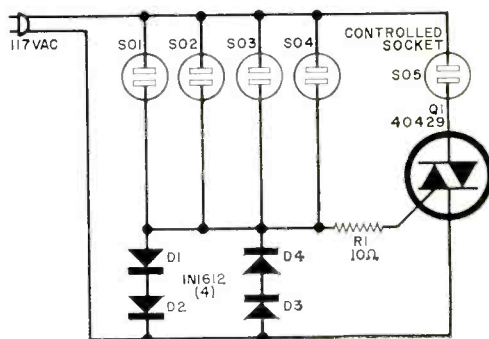

PARTS LIST

- D1-D4*—50-PIV, 5-ampere silicon diode (1N1612 or similar)
- Q1*—200-volt, 6-ampere triac (RCA40429, SK3506)
- R1*—10-ohm, $\frac{1}{2}$ -watt resistor
- Misc.—Chassis-mounted ac receptacle (5), mounting bracket, mounting hardware, suitable chassis, line cord, grommets, etc.

they are all turned on at one time. Since the diodes are connected in series and back-to-back, they never receive more than a couple of volts in the reverse direction. Therefore, silicon diodes (or silicon power transistors connected as rectifiers) with the lowest PIV rating can be used. Be sure the rectifiers are silicon or the forward voltage drop won't be enough to trigger *Q1*. Triac *Q1* must have a current rating only high enough to handle the main amplifier load connected to the controlled socket.

Construction. Since the amount of wiring and components required is small, a wide variety of construction methods is possible. If only one controlling socket is needed, the unit can be built inside a standard wall outlet box. Another technique would be to use a multiple power outlet box.

The prototype was constructed in a 4" x 2 3/8" x 1 3/8" box, which is about the minimum size for handling four controlling input sockets. Use insulated mounting hardware for the diodes and triac and check carefully for leakage to the chassis to make sure there is no shock hazard. Use an ohmmeter to check for leakage. Make sure bare leads or terminals can't come in contact with the chassis.

Test the circuit by connecting a 100-watt lamp to *SO5*. With a small load applied to one of the controlling sockets (*SO1* through *SO4*), the lamp should turn on to full brightness. If the lamp is dim, it might indicate a defective triac, which is firing only on alternate half cycles; in which case you will need an oscilloscope for further troubleshooting. With a little imagination, you can probably think of several more uses. ♦

GET PC BOARD BLANK CLEANER FROM PHOTO SUPPLY HOUSE

Before applying the resist, most people clean the copper surface of their PC board blanks with an abrasive scouring powder that leaves a surface over which it is difficult to apply the resist evenly. A better cleaner, 28-percent acetic acid (not glacial acetic acid, which is too strong), can be obtained from any photography supply house. Add to the bottle of acetic acid a half teaspoon of table salt and gently shake until the salt has completely dissolved. Now, wearing rubber gloves, wet a large wad of cotton with the solution and rub the copper surface vigorously until it is clean. Thoroughly rinse the PC blank under running water and pat dry with a lint-free cloth. —Garry H. Barnett

A COMPLETE SET OF

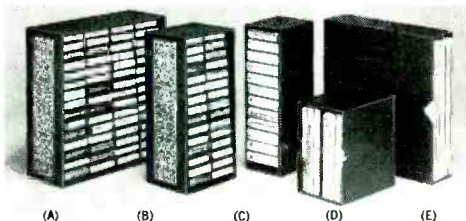

- (A) 60-unit cassette case. 13 1/2" high x 12 3/8" deep x 5 1/2" wide.
 - (B) 30-unit cassette case. 13 1/2" high x 6 1/2" deep x 5 1/2" wide.
 - (C) 12-unit cartridge case. 13 1/4" high x 6 1/2" deep x 4 1/4" wide.
- Units A, B and C have tilted compartments to prevent spillage and include pressure sensitive labels for titling.
- (D) 6-unit 7" reel case. 8" high x 7 1/2" deep x 5" wide. Holds reels in original boxes.
 - (E) 20-unit 12" record case. 13 1/4" high x 12 1/2" deep x 3 1/2" wide. Holds records in original jackets.

Here's the ideal solution to the problem of keeping your records and tapes stored conveniently and attractively. Now you can keep them side-by-side on your bookshelf or cabinet, easy to identify and readily available.

Sturdily constructed and covered in a handsome leatherette, the outer case is elegantly embossed in gold and comes in your choice of three popular decorator colors — black, brown and green — lending themselves readily to the decor of any room.



CHARGE YOUR STORAGE CASE ORDERS TO YOUR AMERICAN EXPRESS OR BANKAMERICARD ACCOUNT



ZIFF-DAVIS PUBLISHING COMPANY, DEPT. 23
One Park Avenue, New York, N.Y. 10016

EEHW-75

- My remittance in the amount of \$ _____ is enclosed for the cases indicated
- Charge: American Express BankAmericard

Account # _____

Signature _____

- _____ 60-unit Cassette Cases @ \$15.95 each; 3 for \$45.00
- _____ 30-unit Cassette Cases @ \$11.95 each; 3 for \$33.00
- _____ 12-unit 8-Track Cartridge Cases @ \$7.95 each; 3 for \$22.00
- _____ 6-unit 7" Reel Cases @ \$5.25 each; 3 for \$15.00
- _____ 20-unit 12" Record Cases @ \$5.95 each; 3 for \$17.00

Add 50¢ per unit ordered for postage and handling. Outside U.S.A. add \$1.00 per unit ordered. Payment must be enclosed with order if not charged.

Check color choice for back of case (sides in black only):

- Brown Green Black

Print Name _____

Address _____

City _____

State _____ Zip _____

Electronic Circuit Analogy Quiz







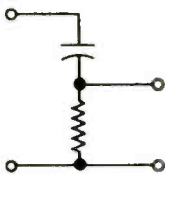
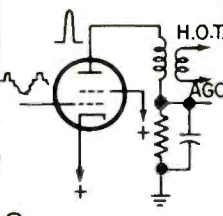

BY ROBERT P. BALIN

Electronic circuits perform functions that are similar in many respects to those of common mechanical devices. For example, a rectifier circuit produces unidirectional current while a ratchet and pawl produce unidirectional motion. If you can see an analogy between them, you probably have

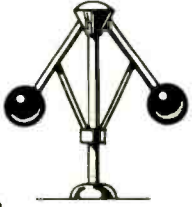
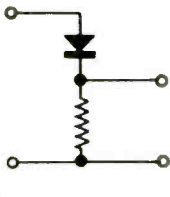
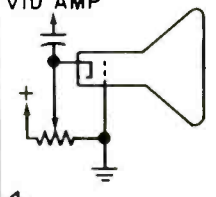
a good understanding of their operating principles.

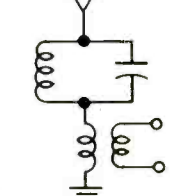
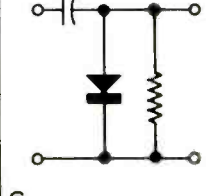
To test your ability to identify analogies, try to match the electronic circuits (1 to 8) on the left below to the related mechanical devices (A to H) which are depicted on the right below.

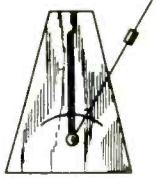
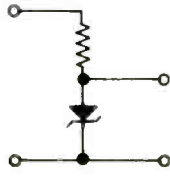
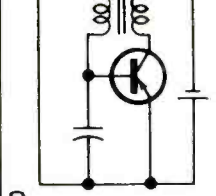
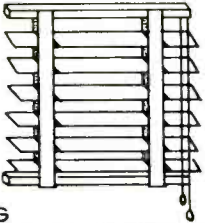
(Answers below. No peeking.)

<p>1</p> 	<p>2</p> 	<p>A</p> 	<p>B</p> 
<p>3</p> 	<p>4</p> 	<p>C</p> 	<p>D</p> 
<p>5</p> 	<p>6</p> 	<p>E</p> 	<p>F</p> 
<p>7</p> 	<p>8</p> 	<p>G</p> 	<p>H</p> 

1. High-pass filter
 2. Agc keyer circuit
 3. Clipper circuit
 4. Brightness control
 5. Wave trap
 6. Clamping circuit
 7. Regulator circuit
 8. Oscillator circuit
 A. C-clamp
 B. Centrifugal governor
 C. Hedge clippers
 D. Drain trap
 E. Lock and key
 F. Metronome
 G. Venetian blinds
 H. Flour sieve

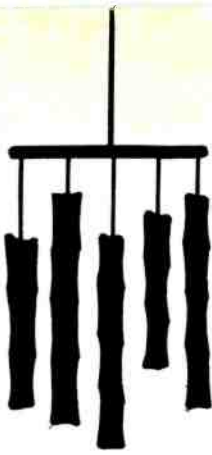

ELECTRONIC Wind Chimes

THE TINKLING SOUND OF A SUMMER BREEZE
THROUGH YOUR AMPLIFIER SYSTEM

BY JOHN S. SIMONTON, JR.

WITHOUT stretching a point too much, you could call wind chimes the original background music with no power other than the wind.

Now, you can build a set of electronic wind chimes that doesn't rely on the wind for power so you can use it indoors or out, windy days or still.

How It Works. The operation of the wind chimes as a system can easily be understood by referring to Fig. 1, which shows one of the three identical channels that make up the complete unit. The principal operational divisions are a random voltage generator, a comparator, and a ringing oscillator. The output of the random voltage generator is compared to the voltage developed across *C* as it charges through *R* and a pulse is generated at the comparator output whenever the random voltage is within about a half volt of the capacitor voltage. Each pulse from the comparator triggers the associated ringing oscillator and simultaneously discharges *C* slightly so that the voltage across this capacitor never reaches the supply level.

The complete schematic is shown in Fig. 2. The three random voltage generators are made up from transistors *Q1* through *Q6* which are wired to form 3 separate astable

multivibrators. The time constants of these astables have been selected so that their combined periods and duty factors produce a long-duration, pseudo-random pattern. The outputs of these astables are summed by resistive networks (*R13*, *R14* and *R15*; *R16*, *R17* and *R18*; *R19*, *R20* and *R21*) to produce three different randomly varying voltages. Each of these voltages is smoothed by a capacitor (*C10*, *C11* and *C12*) and applied to the base-2 terminal of a unijunction transistor. The emitter of each UJT connects to a capacitor (*C13*, *C14* and *C15*) which is charged through a resistor from the supply (*R22*, *R24* and *R26*).

At some random time the voltage at the emitter gets close enough to the base-2 voltage to allow the UJT to fire. This causes the capacitor to discharge through the emitter/base-1 junction and a pulse to develop across the base-1 resistor (*R37*, *R38* and *R39*).

The ringing oscillators are parallel-T types consisting of a transistor gain stage (*Q10*, *Q11* and *Q12*) with a parallel-T notch filter in the feedback loop. A trimmer potentiometer (*R46*, *R47* and *R48*) in each T adjusts the loss of the network so that the circuit can be set just below the point of oscillation. Each pulse from the UJT kicks the circuit into the rapidly decaying oscillation characteristic of a chime. The outputs of the three individual oscillators are mixed in a resistor matrix (*R49*, *R50* and *R51*) and capacitively coupled to the output.

Zener diode *D1* is used to eliminate voltage variations resulting from battery aging which would otherwise change the gain (and consequently sustain) characteristics of the ringing oscillators.

Resistors *R54*, *R55* and *R56* couple some

Fig. 1. When random voltage exceeds charge on *C*, the comparator output triggers the ringing oscillator circuit.

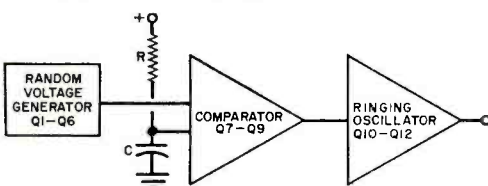

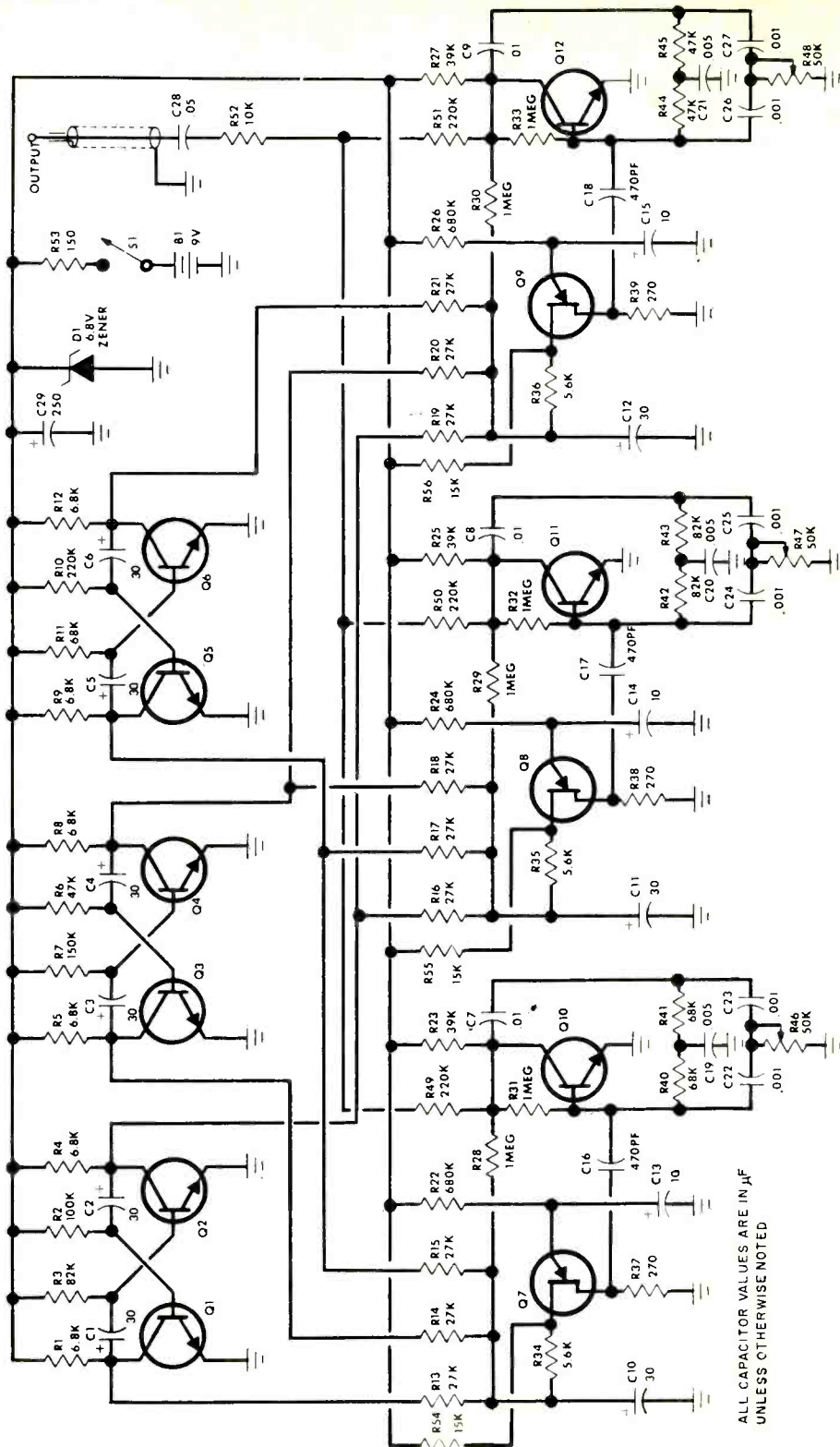

ALL CAPACITOR VALUES ARE IN μF UNLESS OTHERWISE NOTED

Fig. 2. The voltages from the three random-voltage generating multivibrators (Q1-Q6) are compared in the UJT circuits (Q7-Q9). When the UJT fires, it triggers its tone generators. Outputs of three tone generators are mixed in resistors.

of the random voltage generator output directly to the ringing oscillators in such a way that, when the random voltage is high, the gain and sustain duration of the oscillators is increased. This squelching action allows the sustain on some of the strikes to be considerably longer than would otherwise be possible because of the danger of the circuit breaking into continuous oscillation.

Assembly. Any assembly technique from point-to-point wiring to perf-board may be used for the wind chimes but etched circuit boards will produce the most trouble-free and professional looking unit with the

least hassle. Circuit boards may be etched using the full size layouts shown in Fig. 3 or purchased from the source listed. Note that two PC boards are used to keep the project small. One board mounts the three multivibrators, while the other board contains the remainder of the circuit. Spacers are used between the boards.

Assembly of each board is relatively straightforward. Observe the polarity of all electrolytic capacitors and the zener diode, use care in installing the transistors to make sure that they are properly oriented. As with most printed circuit construction, use a small soldering iron rated at no more than 35 watts and just to be on the safe side heat-sink the leads of the transistor and diode while soldering them in place. Some of the pads on the PC board are close together so be particularly careful of solder bridges.

Mount the components on the circuit boards following the parts placement diagrams. Epoxy can be used to fasten a battery clip to the larger board so that it holds the battery in the position indicated. Roughen both mating surfaces with sand paper before gluing and note that the clip must be positioned so that the battery can be inserted from the side. Save the mounting of resistors *R49*, *R50* and *R51* for last and when you get to these parts note that one of the leads of each resistor passes completely through the PC board they mount on and mates with the connecting points marked "X" on the lower board.

For convenience we will at this point designate the smaller of the two boards the tone board and the larger of the two the RVG (random voltage generator) board. Solder lengths of #22 insulated wire to points "A", "B", "C", "D", "E" and "G" on the tone board. Make sure that these wires are long enough to reach to the corresponding points on the RVG board when the two are placed one above the other. Fasten the two circuit boards together (tone board above the RVG board) using 1" stand-offs and 4-40 × 1/4" machine screws. Orient the two boards so that the long leads from resistors *R49*-*R51* pass through the "X" holes on the RVG board. Trim the leads from the tone board to proper length and solder them to the corresponding points ("A" through "G") on the RVG board.

Finish assembly by hooking up the battery connector and switch to the "+" and "-" points on the RVG board and using a

PARTS LIST

- B1*—9-volt transistor battery
C1-*C6*, *C10*-*C12*—30- μ F, 10-volt electrolytic capacitor
C7-*C9*—0.01- μ F disc capacitor
C13-*C15*—10- μ F, 10-volt electrolytic capacitor
C16-*C18*—470-pF disc capacitor
C19-*C21*—0.005- μ F disc capacitor
C22-*C27*—0.001- μ F disc capacitor
C28—0.05- μ F disc capacitor
C29—250- μ F, 10-volt electrolytic capacitor
D1—6.8-volt zener diode
Q1-*Q6*—2N5129 transistor
Q7-*Q9*—2N4871 UJT
Q10-*Q12*—2N2712 transistor
R1, *R4*, *R5*, *R8*, *R9*, *R12*—6800-ohm, 1/2W, 10% resistor
R2—100,000-ohm, 1/2W, 10% resistor
R3, *R42*, *R43*—82,000-ohm, 1/2W, 10% resistor
R6, *R44*, *R45*—47,000-ohm, 1/2W, 10% resistor
R7—150,000-ohm, 1/2W, 10% resistor
R10, *R49*, *R50*, *R51*—220,000-ohm, 1/2W, 10% resistor
R11, *R40*, *R41*—68,000-ohm, 1/2W, 10% resistor
R13-*R21*—27,000-ohm, 1/2W, 10% resistor
R22, *R24*, *R26*—680,000-ohm, 1/2W, 10% resistor
R23, *R25*, *R27*—39,000-ohm, 1/2W, 10% resistor
R28-*R33*—1-megohm, 1/2W, 10% resistor
R34-*R36*—5600-ohm, 1/2W, 10% resistor
R37-*R39*—270-ohm, 1/2W, 10% resistor
R46-*R48*—50,000-ohm PC trimmer potentiometer
R52—10,000-ohm, 1/2W, 10% resistor
R53—150-ohm, 1/2W, 10% resistor
R54, *R55*, *R56*—15,000-ohm, 1/2W, 10% resistor
S1—Spst switch
Misc.—Circuit boards, wire, solder, 1" and 1/4" standoffs, battery connector and clip, 4-40 hardware, case, phono plug, etc.
Note—The following are available from PAIA Electronics, Inc., Box 14359, Oklahoma City, OK 73114: set of etched and drilled circuit boards (3721pc) at \$3.50 postpaid; complete kit of parts including PC boards but less case (3721K) at \$17.95 postpaid; case as shown (3711c) at \$2.50 plus postage for 1 lb.

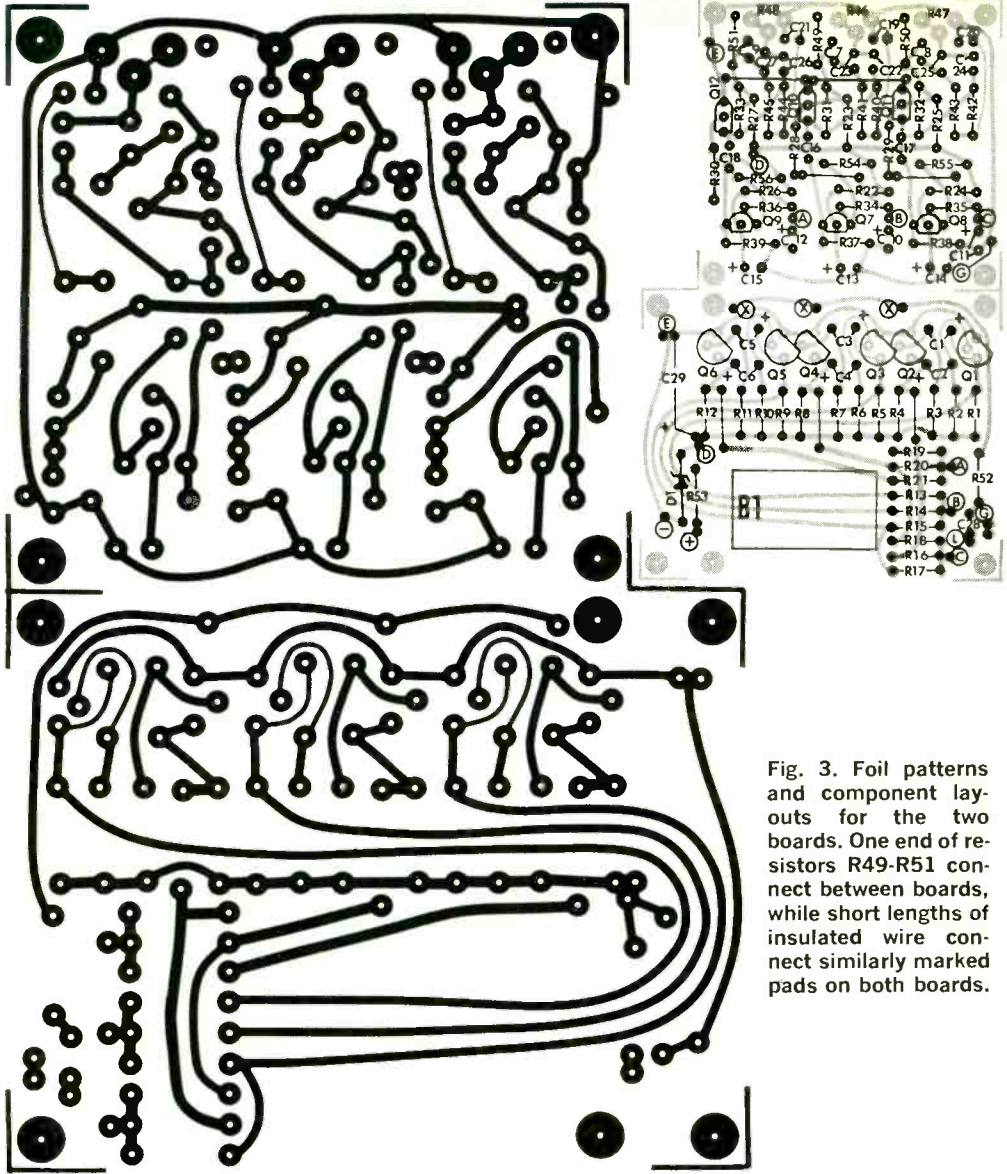

Fig. 3. Foil patterns and component layouts for the two boards. One end of resistors R49-R51 connect between boards, while short lengths of insulated wire connect similarly marked pads on both boards.

length of RG-174/U or similar thin coax or audio cable to make the connection between RVG board points "G" (coax shield) and "L" and whatever type of plug matches the amplifier you will be using.

Testing and Operation. The unit is now ready to test. Check over all connections and component parts and snap a fresh 9-volt battery into the battery connector and clip the battery into the battery holder.

Plug the output into one of the auxiliary inputs of a hi-fi or musical instrument am-

plifier and turn on the amplifier and wind chimes. Rotate the adjusting discs of trimmer controls R46, R47 and R48 fully clockwise as viewed from the closest edge of the circuit board.

These potentiometers act as sustain controls for the three chimes and regulate the tone between a dull "thunk" and a ringing chime-like tone. One at a time, turn the trimmers from the extreme counterclockwise limits of their rotation. For some part of each trimmer's rotation, a constant tone should be heard from the amplifier and this

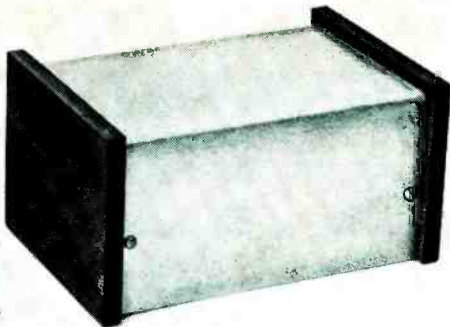
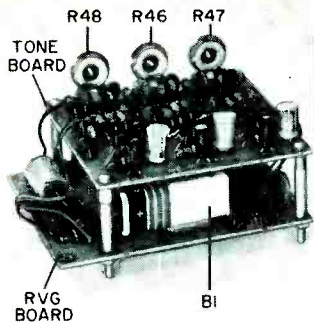

Note how the smaller tone board is mounted over the random voltage generator board. Prototype was mounted in case as shown at the right.

tone should increase in pitch as the control is rotated counterclockwise. At some point before the extreme counterclockwise limit is reached, the tone should cease. After the effect of each trimmer is tested, return it to its clockwise limit. Do not pay any attention to the dull strike tones that you hear at this point.

Once satisfied that all oscillators are operating properly, you can proceed to preliminary adjustments. Beginning with *R46*, advance the trimmer counterclockwise until the point is reached at which the oscillator begins to produce a steady tone and then back off until the tone just stops. At this point you will be listening for two things: a random pattern and the sustain of the oscillator. You will hear a number of dull sounding strikes generated by the other two oscillators which at this stage are detuned but you should also hear a single ringing tone being generated by the oscillator associated with *R46*. Listen to this tone for a few minutes to make sure that the strikes are random. If sustained oscillation occurs while you are listening, back off on the trimmer very slightly.

When satisfied with the setting of *R46* proceed in a like manner to *R47* pausing to assure yourself that the strikes are random and that no sustained oscillation occurs. When satisfied with *R47* proceed to *R48*.

The wind chimes may be mounted in any convenient case. The case illustrated was made of sheet aluminum folded into a U measuring about 5" x 2½" x 3¼". The ends of the U were sealed with walnut blocks having a rabbet cut around each edge. The

ends are held in place by #4 wood screws. Holes in the back of the case allow the output coax to pass through and mount the slide switch. When completely assembled, the slide switch is positioned in the open space above *C29*. The circuit board fastens to the flat aluminum base plate with 4-40 hardware and ¼" stand-offs and the bottom plate in turn attaches to the wood ends with #4 wood screws which also hold 4 rubber feet in place.

Modifications. Ringing chime-like tones are not the only possible sound. By turning the sustain trimmers clockwise, tones, resembling the percussive resonance of bamboo rods or solid wood blocks can be produced. Or for really strange sounds, the trimmers can be turned counterclockwise past the range in which continuous oscillation occurs.

After listening to the chimes for a while you may decide that you would like them better if the strikes were closer together or farther apart. This can be achieved without-destroying the random pattern by varying the values of *R22*, *R24* and *R26*. The practical limits for these resistors are from 470,000 ohms to 2.2 megohms with strike being more closely spaced as the resistance decreases.

The pitch of the oscillators may be changed by varying the value of the resistors in the T filter; *R40* and *R41*, for example. Practical limits are from about 47,000 to 150,000 ohms with the pitch increasing as the resistance is lowered. The two resistors need not be identical. ♦

SIMPLE COMPRESSOR-EXPANDER

"SNAPS UP" ANY PROGRAM MATERIAL

TWO very useful techniques for the audio experimenter are compression and expansion. The compression of the dynamic range of program material (tape, records, or off the air), permits maintaining a constantly high modulation level; while expansion, when used with the compressed material, restores the dynamic realism. You can also use the expansion mode in reproducing conventional program material with some surprising results in many cases.

Creating these effects can be costly and complex; but it need not be if the circuit shown here is used. Although simple in form, this circuit works surprisingly well. It gives a slight, though measurable, amount of distortion, a certain amount of loss (since it is a passive circuit), and some (almost unnoticeable) delay. Nevertheless, in all but the most critical audio applications, the circuit will prove very useful.

As shown in the accompanying diagram, an *LED* is attached to the speaker terminals (via a limiting resistor and volume control) of the audio system to sample the program

material. Diode *DI* and resistor *R1* protect the *LED* against drawing excessive current. Volume control *R2* is used to vary the sensitivity of the circuit. The exact value of *R1* is determined experimentally—with a high-power audio system, a correspondingly high value of *R1* is required to prevent the *LED* from burning out.

The audio modulated light from the *LED* falls on the sensitive surface of a photoresistive cell, *PC1*. To prevent ambient light from becoming a factor, both the *LED* and *PC1* are enclosed in a light-tight tube.

With *S1* switched to **EXPAND**, *PC1* is connected across the high end of the *R3-R4* voltage divider. The output signal at *J2* is then a function of the resistance ratio of *R3* to *R4*. When audio-modulated light from the *LED* strikes *PC1*, which is connected in parallel with *R3*, the composite resistance lowers thus increasing the audio output level. With *S1* on **COMPRESS**, *PC1* and *R5* are in parallel with *R4* and when *PC1* is illuminated by the modulated light from the *LED*, the composite resistance is lowered thus lowering the audio level at *J2*. This, in effect, compresses the signal.

The amount of expansion depends on the resistance values of *R3* and *R4*. A higher value for *R3* means a greater expansion range is possible. Compression depends on the resistance of *R5*. As this value is decreased, the compression effect is increased.

Applications. The circuit can be used as the volume control between the preamp and the power amplifier in an audio system, between the tape deck and preamp, etc.

It can also be used in musical instrument amplifiers to extend the signal-to-noise ratio on expansion or prevent speaker blowout on compression; in PA systems; and in making tape recordings so as to add several dB of signal-to-noise improvement.

By using a switch with a neutral center position for *S1*, the signal can be left unaffected. Two of these units can be connected to a stereo system, to put new life into overly-compressed recordings. ♦

An LED samples audio output of system.

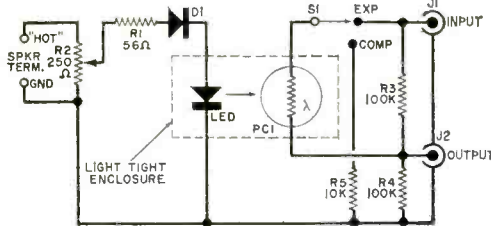

PARTS LIST

- DI*—50PIV, 1A silicon diode
- J1, J2*—Phono connectors
- LED*—Light-emitting diode (Radio Shack 276-026 or similar)
- PC1*—General-purpose cadmium-sulfide cell (Radio Shack 276-116 or similar)
- R1*—56-ohm resistor (see text)
- R2*—250-ohm, 2-watt potentiometer
- R3, R4*—100,000-ohm, 1/2-watt resistor (see text)
- R5*—10,000-ohm, 1/2-watt resistor (see text)
- S1*—Spdt switch
- Misc.—Opaque tube for light-tight enclosure, suitable chassis, knob, etc.

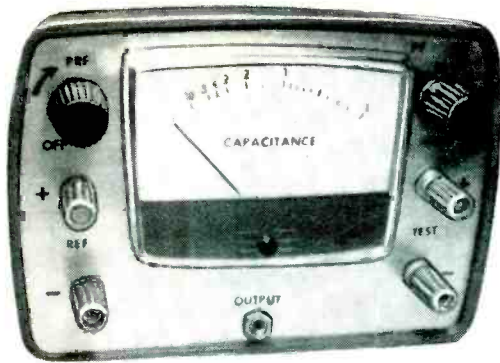

Direct- Reading Capacitance Meter

MEASURES FROM 15 pF to 10 μ F IN FIVE RANGES—
PLUS OPTIONS TO 100 μ F

BY DALE HILEMAN

MOST electronics experimenters have boxes filled with all types of fixed capacitors; and, in most cases, the values are clearly marked. However, there may still be quite a number of perfectly good units whose identification has either rubbed off; or they may have special factory codings that can't be deciphered.

To determine unknown capacitance values, try building the direct-reading capacitance meter described here. (It can also be used as a pulse generator with controllable repetition rate and pulse width.) Capacitance can be read directly from 15 pF to 10 μ F in five ranges; and capacitances larger than 10 μ F can be measured by indirect means.

Power is provided by an 8.4-volt mercury battery. The battery has a rated life of 500 mA-hr; but since, in this case it provides only 2 or 3 mA, 200 hours of service can be expected.

How It Works. As shown in the schematic, the capacitance meter consists basically of a free-running multivibrator ($Q2$ and $Q3$) with $Q4$ driving the meter. Clamp $Q1$ minimizes the effect of changing battery voltage. One of the cross-coupling capacitors in the multivibrator is the unknown, while the other is of a known precision value to which the unknown is compared. The unknown is connected to terminals $J4$ and $J5$, while the precision value ($C1$ through $C4$) is selected

by switch $S1A$. The "off" times of $Q2$ and $Q3$ are determined by the unknown and fixed capacitance values, respectively.

The output of $Q3$ is coupled by emitter follower $Q4$ to integrator $R12$ and $C5$, which forms a low-pass filter for $M1$ so that the meter reading is proportional to pulse rate or duty cycle (pulse width/pulse spacing). Thus, if the fixed and unknown values are equal, the duty cycle is 0.5 and the meter reads about midscale. As the capacitance of the unknown is increased or decreased, the duty cycle decreases or increases proportionately and the meter reading drops or rises accordingly. The extremes at which valid readings may be obtained represent fixed-to-unknown ratios of 0.1 and 10, which points on the meter scale are equidistant from the point representing a ratio of 1.

Since these relationships hold true over a wide range of capacitance values, to switch ranges, it is only necessary to change the fixed value by a convenient whole number. Accordingly, five decade ranges are provided. In the lowest capacitance range, fixed capacitor $C4$ provides an output pulse width of about 60 microseconds. With each step of $S1$, the fixed capacitor is 10 times larger and the output pulse width is 10 times wider—except in the 1- μ F position. A capacitance of 1 μ F in the fixed-value position would result in a pulse width of 0.6 second, too long to be smoothed by the integrator. So the pulse width is held at 60 ms and the

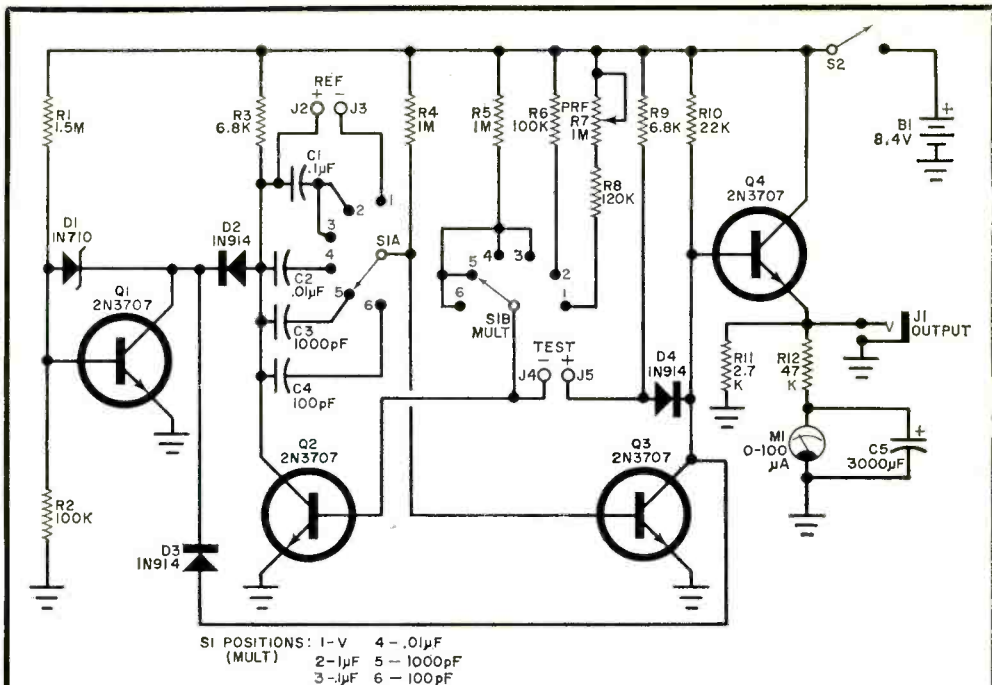

PARTS LIST

B1—8.4-volt mercury battery (Burgess H146X or similar)
 C1—0.1-µF 1% paper or Mylar capacitor
 C2—0.01-µF, 1% paper or Mylar capacitor
 C3—1000-pF, 1% mica capacitor
 C4—100-pF, 1% mica capacitor
 C5—3000-µF, 3-volt electrolytic capacitor
 D1—1N710 zener diode
 D2-D4—1N914 diode
 J1—Phone jack
 J2,J5—Binding post, red
 J3,J4—Binding post, black
 M1—0-100-µA meter
 Q1-Q4—2N3707 transistor
 R1—1.5-megohm, ¼-watt, 10% resistor
 R2—100,000-ohm, ¼-watt, 10% resistor
 R3,R9—6800-ohm, ¼-watt, 5% resistor
 R4,R5—1-megohm, ¼-watt, 5% resistor (matched)
 R6—100,000-ohm, ¼-watt, 10% resistor (see text)

R7—1-megohm audio taper potentiometer (with S2 attached)
 R8—120,000-ohm, ¼-watt, 10% resistor
 R10—22,000-ohm, ¼-watt, 10% resistor
 R11—2700-ohm, ¼-watt, 10% resistor
 R12—47,000-ohm, ¼-watt, 10% resistor (see text)
 S1—2-pole, 6-position rotary switch
 S2—Spst switch (on R7)
 Misc.—Battery connector, perf board with clips, knobs (2, with indices), suitable chassis, mounting hardware, etc.
 Needed for calibration:
 Four 0.01-µF, 1% paper or Mylar capacitors
 One 0.05-µF, 1% paper or Mylar capacitor
 One 0.1-µF, 1% paper or Mylar capacitor
 One 1-µF, 1% paper or Mylar capacitor
 Needed for test (optional):
 One 100-pF, 1% mica capacitor
 One 15-pF, 1% mica capacitor

Meter circuit is basically a free-running multivibrator which compares capacitances.

charging time is reduced tenfold when S1B switches from R5 to R6, the latter being selected during calibration.

When S1A is in position 1, a reference capacitor can be connected externally to J2 and J3 to determine pulse width. At the same time, S1B connects potentiometer R7 to the charging circuit so that the pulse repetition rate can be adjusted. The rate range is then determined by the value of a capacitor connected to J4 and J5. Resistor R8 sets the upper limit of the rate range. It may be

selected as described under calibration or as required to suit the needs of the user. But it should be no smaller than 27,000 ohms.

Potentiometer R7 is connected to provide higher repetition rate with clockwise rotation. If the builder is satisfied with the opposite direction of control, connecting R8 to the counterclockwise terminal will spread out the high end of the rate range, if R7 has a normal audio taper.

Diode D4 isolates the collector circuit of Q3 from the charging circuit of the unknown

capacitor to improve the rise time of the output pulse.

Clamp *Q1* stabilizes the meter reading with changing battery voltage by holding the peak collector voltage of *Q2* or *Q3* to 5.7 volts. The clamp is coupled to the two collectors through isolation diodes *D2* and *D3*. Zener diode *D1*, though rated at 6.8 volts, actually begins conducting at about 4.7 volts and does not rise above this value because the zener current required to institute the regulating action is so small. The additional volt is accounted for in the forward drop of *D2* and *D3* in series with *Q1*. It is the conduction of *Q1* that provides the shunt regulating action.

Construction. The capacitance meter can be constructed in any enclosure and most of the circuitry can be assembled on perf board mounted on the meter terminals. To minimize stray capacitance effects, certain resistance values that might have been adjustable—specifically *R6* and *R12*—are individually selected. Long leads should be left on these resistors to minimize value changes due to soldering heat. If, however, you want to use potentiometers use 25,000 ohms for *R6*, in series with 91,000 ohms fixed; and for *R12*, a 50,000-ohm potentiometer in series with 27,000 ohms fixed.

Sometimes a 2N3707 or 1N710 may prove troublesome, so the builder is advised to obtain a few extra of both, preferably from a different supplier, to reduce the probability of drawing each lot from a marginal batch.

In the prototype, all common connections, except *J1*, were made to a ground bus which was connected to the chassis at the emitter of *Q3*. No ground loops were apparent from the direct connection of *J1* to the chassis.

Calibration. Capacitors needed for calibration are given in the Parts List. Before starting calibration, note the following:

1. The terminal voltage of a new Burgess Type H146X 8.4-volt mercury battery is over 9 volts. Although the capacitance meter is quite stable with changing voltage, it is advisable to turn the instrument on for about 15 minutes so that the battery voltage settles down to 8.4.

2. Be sure the instrument is not in a draft from air conditioning or windows since the slightest breeze will affect needle position.

3. After changing each capacitance value,

allow plenty of time for the needle to settle down as the RC constant of the integrator is quite high. Then, using the eraser end of a pencil, very gently tap the instrument once. Even the best D'Arsonval movements tend to stick a little with dc applied, and a tap will free the needle.

4. Mark each calibration point on the meter face lightly, in pencil, deferring final art work until satisfied with performance.

5. When replacing the meter cover, be especially careful to ensure that the mechanical zero adjustment finger properly engages its slot.

Calibrate as follows:

1. Set meter mechanical zero at mid-position.

2. Turn *S1* to the .1- μF position and connect an 0.01- μF calibration capacitor to *J4* and *J5*.

3. Select a value for *R12* that places the needle at full scale.

4. Remove meter cover and mark this point .1.

5. Successively increase calibration capacitance in 0.01- μF steps marking each point, and ending with 0.1 μF , to be labeled 1.

6. Add 0.05 μF for a total of 0.15 μF and mark this point. Remove the capacitors.

7. Place *S1* on .01 μF and connect a 0.01- μF capacitor to *J4* and *J5*. The needle should return to the last point marked in step 5.

8. Successively increase calibration capacitance in 0.01- μF steps, marking each point and ending with 0.05 μF (points to be labeled 2 through 5). Remove capacitors.

9. Connect a 0.1- μF capacitor to *J4* and *J5* and mark this point 10. Remove capacitor.

10. Place *S1* on 1 μF and connect a 1- μF capacitor to *J4* and *J5*. Select a value for *R6*

Perf board is mounted on meter terminals.

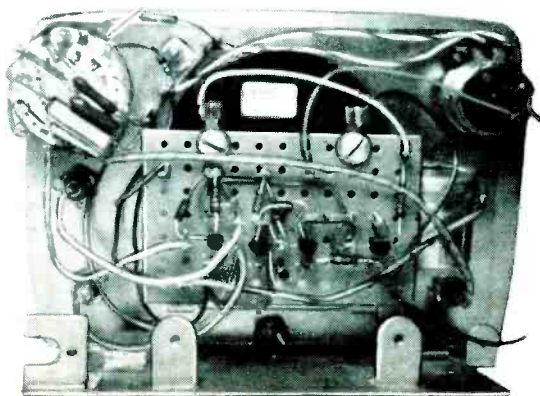

that places the needle exactly at the last point marked in step 5.

11. Turn off power. Allow needle to settle, and mark this point.

12. Double check the calibration by measuring a number of capacitance values on different ranges. If satisfied, remove meter face and perform final art work.

Different methods of measuring capacitance above 10 μF can be used, but here is one method of measuring values from 10 μF to 100 μF that does not require removing the meter cover. Although they are not included in the Parts List, a number of capacitor values in the 10-to-100- μF range will be needed. The selection of values and tolerances are left to your discretion. One 10- μF capacitor is required for the reference. Electrolytics should be thoroughly formed. Voltage ratings should be at least 6 volts. Be sure to observe polarities. The procedure is as follows:

1. Connect a 10- μF capacitor to *J2* and *J3* and 100 μF to *J4* and *J5*. Put *S1* on position 1.

2. Turn power on and set *R7* to its minimum resistance. The needle should swing back and forth across almost the entire scale.

3. Select a value for *R8* that places the left end of the swing as nearly as possible to 10. Then adjust *R7*, if necessary, to attain exactly this swing. Label this point 100 on *R7*. Remove the 100- μF capacitor.

4. Successively connect the large-value calibration capacitors to *J4* and *J5*. In each case, adjust *R7* to set the swing as described in step 3. Then label the corresponding point on *R7* with the capacitance value.

Operation. To measure capacitance values in the range of 15 pF to 10 μF , turn on the power, turn *S1* to the appropriate position, and connect the unknown to *J4* and *J5*.

Depending on your luck in selecting the 2N3707's, the instrument will indicate accurately to 10 pF. A value below 10 pF, however, may yield a spurious reading, usually just to the left of .1 on the meter. Unless you are sure that an unknown is above 10 pF, therefore, disregard any indications below 15 pF.

If the instrument has been calibrated for larger capacitors, use the following procedure (being sure to observe polarity):

1. Connect a 10- μF capacitor to *J2* and *J3*. Preferably use the same capacitor that was used in calibration.

2. Turn *S1* to position 1.

3. Connect the unknown to binding posts *J4* and *J5*.

4. Adjust *R7* to place the left end of the needle swing at 10. Read the unknown value from the *R7* calibration.

Values over 100 μF can be measured with a stop watch, timing the period between upward swings of the needle. Any such measurements, however, should be considered only as estimates because capacitors with very large values usually leak; and leakage affects the time constant.

As an optional feature, the multivibrator output pulses are available from *J1* so that the unit can be used as a pulse generator. Pulse spacing is determined by the value of a capacitor connected to *J4* and *J5*, while pulse width depends on the setting of *S1*. For variable (\bar{V}) prf, use position 1 of *S1*, where pulse width is determined by a capacitor connected to *J2* and *J3* and pulse spacing adjusted by changing *R7*.

In Case of Trouble. Any small drift that may occur due to aging of parts or imperfect performance of the circuit should be compensated for by adjusting the meter mechanical zero, or in case of larger errors, by changing the value of *R12*.

If inaccurate readings are obtained, especially on low capacitance ranges, either the common lead is not connected to the chassis base or there is a marginal transistor in the multivibrator. To evaluate the performance of the multivibrator, proceed as follows: Set *S1* to 100 pF and connect a 100-pF capacitor to *J4* and *J5*. Connect a scope to *J1* and measure pulse width. It should be about 60 μs . Now replace the 100-pF capacitor with one of 15 pF. The pulse width should not change. If it does, try replacing *Q2* or *Q3*.

If accuracy varies with battery voltage, the cause is probably a marginal zener diode at *D1*. The 1N710 was not designed for this application but is used here because the more suitable low-current types are more expensive. Using the oscilloscope, check the peak output voltage of the pulse at *J1*. If it is higher than 5.3 volts, the regulating action will suffer at lower battery voltages; so try replacing *D1*. If the peak voltage is 5.3 volts or less but the problem persists, try replacing *Q1*. The meter indication should remain steady over a range of battery voltages from 7.2 to 9 volts. If the circuit is operating properly, more nearly perfect results may possibly be obtained by selecting the value of resistor *R1*. \blacklozenge



A PREAMPLIFIER *for your* SCOPE

BUILD THIS

X10 AMPLIFIER TO INCREASE SCOPE USEFULNESS

FREQUENTLY, when using an oscilloscope to check low-level signals, we wish that our scope had more gain. Suppose, for instance, that the scope's maximum vertical sensitivity is 50 mV (peak-to-peak) per inch or centimeter. With a typical low-capacitance probe (10 megohms, 8-35 pF) which has an attenuation of 10:1, one scope division may represent half a volt. Of course, the gain can be increased by using a straight-through probe instead of the low-capacitance probe. Unfortunately, this may be impractical with a high source impedance or at high frequencies.

So how do we get higher gain? We use a scope preamplifier. The low-cost preamp whose schematic is shown in Fig. 1 can be used to fill the probe-sensitivity gap. It has a voltage gain of 10 and a bandwidth of about 5 MHz; and it can be used with any scope. The integrated circuit used was developed for the 45-MHz i-f range in TV and

has high gain and low noise. With careful layout and choice of components, the bandwidth can easily be extended to 30 MHz or more. The IC also has automatic gain control, which can be adjusted.

How It Works. The input connector (*J1*) should fit the probe you are going to use with the preamp. The output connector (*J2*) is a BNC type, which should be used on the scope vertical input if it is not already there. If your scope uses a pair of banana jacks, now is the time to upgrade it with a good shielded coaxial connector.

The input stage is a field-effect transistor. It may be necessary to add extra capacitance (*C2A*) at the input, as discussed later under "Alignment." The signal at the source of *Q1* is connected to the input of *IC1* through *C3*. Resistors *R4* and *R5* are the load resistors for the IC, and the output signal is taken from the non-inverting output at pin 8.

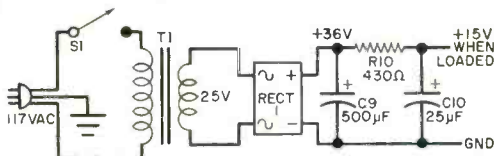

Fig. 2. The 15-volt, 85-mA supply to be used if not available elsewhere.

wiring is without pins. The IC socket is mounted on the non-foil side of the board after first drilling the necessary holes. With the exception of pins 3 and 7, all holes should have the copper cleared from around them. Use a larger bit (manually) to do the scraping. Note that IC1 only uses pins one through four and 11 through 14 of a conventional 14-pin in-line socket. Solder socket pins 3 and 13 (IC1 pin 7) to the foil. All the other components are mounted on the foil side using point-to-point wiring of the component leads and the foil as ground.

The completed board is mounted with standoffs in a 4" × 2 1/8" × 1 1/8" metal enclosure. Before installing the board, drill holes for input jack J1, selector switch S1, and the power leads and coaxial cable. The last two holes must be fitted with grommets.

The power supply shown in Fig. 2 is optional if the required 15 volts at 85 mA is available elsewhere. However, if this supply is used, do not turn it on unless it is connected to the amplifier. Without D2, the supply can reach about 36 volts, which might damage electrolytic capacitor C10.

Alignment. Using a 10:1 probe as the in-

put to the preamplifier, supply power and connect the probe to a source of 1 volt, peak-to-peak, at about 1 kHz. Adjust R6 to obtain a 1-volt peak-to-peak indication on the scope.

Now connect the probe to a 0.5-volt peak-to-peak square wave and place S1 in the DIRECT position. You should see a 50-mV square wave on the scope. Adjust the probe frequency-compensation trimmer capacitor for sharp corners without overshoot. Switch S1 on the preamp to the X10 position and adjust C2 to obtain a clean square wave without overshoot. If C2 cannot be adjusted for the desired effect, add another small capacitor (C2A) in parallel—try 33 pF. In some cases, the scope vertical input compensation trimmer may also have to be adjusted.

If you now replace the 10:1 probe with a direct probe, a 50-mV signal will produce a 0.5-volt deflection on the scope. The direct output of a magnetic cartridge (approximately 5 mV) can be seen easily on the 50-mV input position of the scope's vertical input.

Do not allow the dc voltage at the input of the preamplifier to exceed the voltage rating of C1 and do not apply more than 1 volt, peak-to-peak, to the probe if S1 is in the X10 position.

If desired, the preamp can be built directly into the scope, with the scope's vertical gain switch changed accordingly, although the circuit was originally designed as an outboard unit and works well as a separately housed scope preamp. ♦

The power supply is in one chassis (left) and the preamplifier in another. Note how component leads in the preamp are soldered together for mounting.

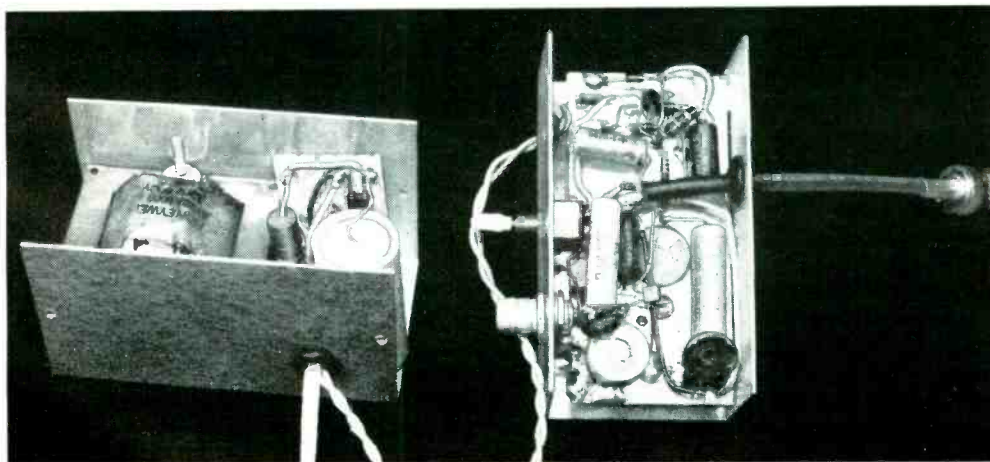

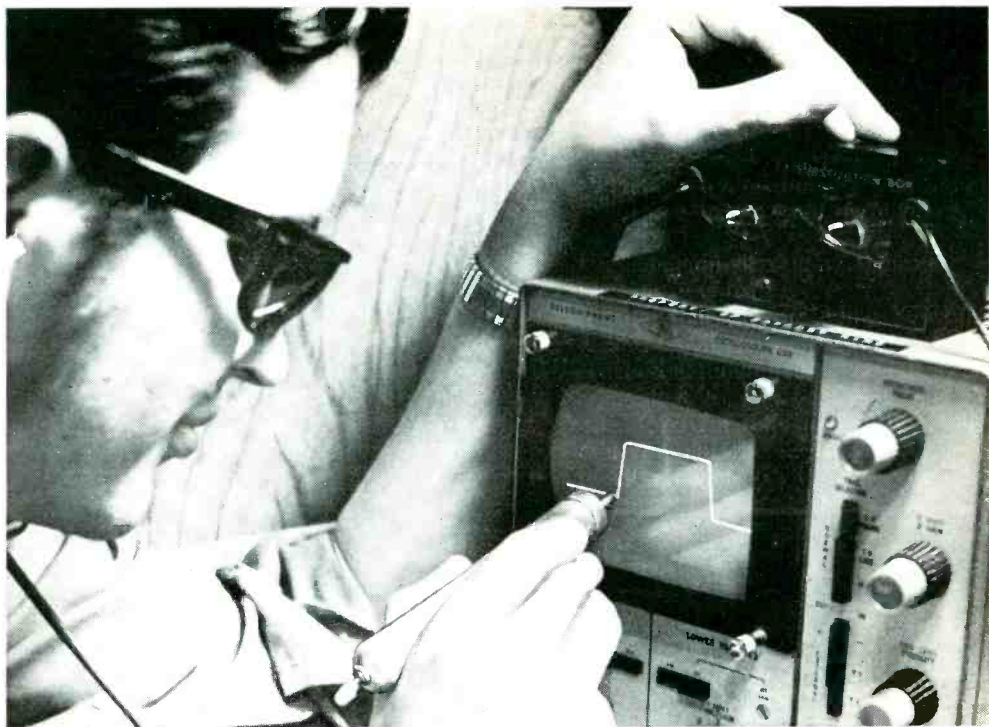

Build a LIGHT PROBE

ELECTRONIC HELP FOR THE BLIND

BY FORREST MIMS

IF YOU have a blind relative or friend, here is a chance to provide him with a simple-to-use light probe that will enable rapid location of pilot lights on a panel, switchboard, or multi-extension telephone; orient his position with respect to the sun; or even "read" the hands on a conventional clock.

A blind person can use the probe to detect the presence or absence of artificial illumination within a room; and it could even be employed to read the waveforms on a scope.

The circuit (Fig. 1) consists of a simple two-transistor audio oscillator whose output frequency is dependent on the amount of

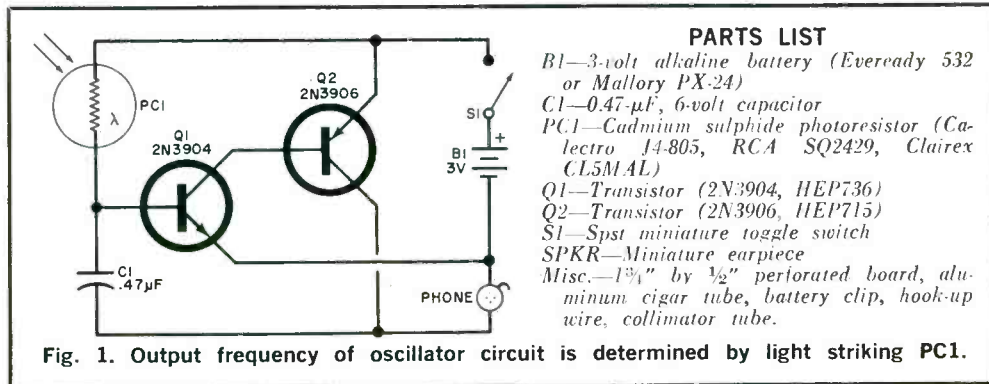

Fig. 1. Output frequency of oscillator circuit is determined by light striking PC1.

light striking the sensitive surface of a photoresistor (*PCI*). The prototype has a frequency range of up to 5500 Hz, depending on the amount of light striking *PCI*.

Construction. As shown in the photograph, all components except for the battery and on-off switch are mounted on a $1\frac{1}{2}$ " by $\frac{1}{2}$ " piece of perf board. The photoresistor is mounted at one end, at right angles to the board. Before mounting the miniature earphone which is to act as the speaker, remove the plastic sound guide (the part that goes in the ear), cut the leads to about one inch, and remove a small portion of the insulation. Push the leads through a hole in the board, press the earpiece close to the board and solder the two leads in place to secure the earpiece. A drop of cement may be used to form a secure mount.

The final assembly is best made in an aluminum cigar tube measuring $5\frac{1}{4}$ " by $\frac{3}{8}$ ". Lay the finished perf board assembly beside the tube and mount a battery clip (for the 3-volt alkaline battery) and switch *SI* so that *SI* will protrude through the round end of the cigar tube (see photograph). Use heavy wire for this installation so that the entire assembly can be easily inserted or removed from the tube.

Use a sharp punch and miniature file to form the mounting hole for *SI* at the round end of the tube. Do not use a drill for this hole, unless you have a small hobby-type drill, as the aluminum tube is very thin and can distort very easily. Another hole, this one about $\frac{1}{8}$ " in diameter, should be made in

the wall of the tube, directly opposite where the speaker will be located when the assembly is in the tube.

The assembly must be made so that the sensitive surface of the photoresistor is close to the open end of the tube. You can either make a small hole in the cigar tube cap to allow the outside light to strike the photoresistor, or you can use a discarded clock gear wheel having a hollow axle as a light guide. The axle can be inserted from the inside of the cap and the gear wheel cemented to the cap as the support.

Operation and Use. To test the probe, turn on *SI* and aim the probe at different light sources around the room. There will be many different tones heard as the probe sweeps the room. If you find that the probe is too sensitive and cuts off at relatively low light levels, use a small piece of polarizing material on the interior of the light hole in the cap and another small piece covering the photoresistor. (Be sure that the cement does not cover the sensitive surface.) The light input can then be controlled by rotating the cap to cross the polarizers.

The light probe can be modified for special applications. For example, a miniature lamp mounted near the cap can be used to illuminate dark areas to improve the probe's ability to "read" clock hands or meter pointer positions. A blind electrical engineering student has successfully used the prototype with a narrow-bore light collimator (tube) to read the waveforms displayed on a CRT and the panel lights on a computer board. ♦

Components, except for battery and switch, are mounted on a small piece of perf board and entire assembly is inserted in aluminum cigar tube with light collimator in cap.

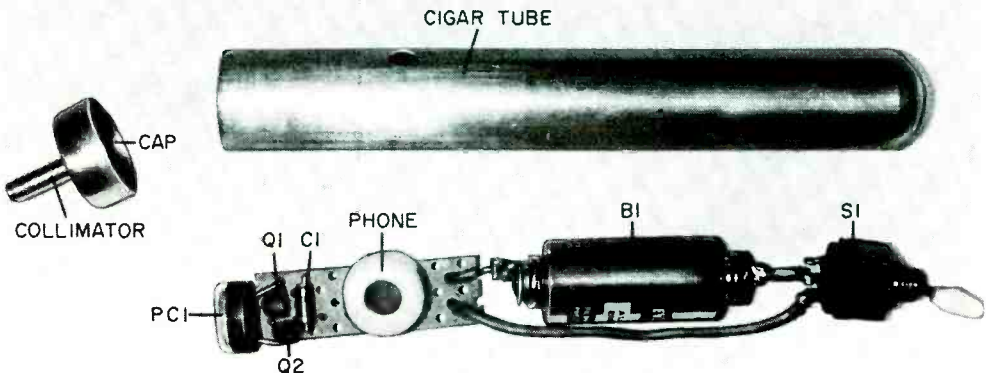

ANTENNA TUNER FOR SWL's

**LOW-COST FRONT END INCREASES SIGNAL STRENGTH
AND IMPROVES SELECTIVITY**

BY CARL C. DRUMELLER

SHORTWAVE receivers for serious listening are usually designed for use with a low-impedance antenna input; but the doublet antenna, which is normally used for low-impedance feedlines, works best over a narrow band of frequencies. So, if you have a general coverage (0.55 to 30 MHz) receiver, it is desirable to have a low-impedance input over a wide frequency range. For this, you need an antenna tuner.

The circuit shown here provides a low-impedance input over a wide frequency range and also improves receiver selectivity. The additional selectivity occurs before the first active stage (tube or transistor) of the receiver and thereby lessens the effects of image interference, cross modulation, and intermodulation. By omitting the 0.5-to-1.8-MHz range where most receivers perform quite well and by deleting the 15-to-30-MHz range where an amplifying preselector is often needed, the tuner design is very simple.

The tuner consists of a tapped coil ($L1$) and a variable capacitor ($C1$). The latter can be switched so that it is either in series or parallel with the coil. Connected to a random-length, end-fed antenna, the circuit can be tuned for resonance at the frequency of the incoming signal—with a low-impedance output. Its tuning is not critical, but it provides enough front-end selectivity to reduce appreciably the image interference. The apparent "gain" results from a resonant antenna and matched receiver input, which boosts the signal strength. Since it is passive, the tuner does not provide any actual gain, the increase in signal strength resulting from more selective use of the signal power.

The tuner is mounted in a small metal enclosure with the three operational controls on the front panel. Switch $S1$ is used to select either series or parallel tuning of $L1$, while $S2$ is used to vary the inductance. The antenna input and receiver output con-

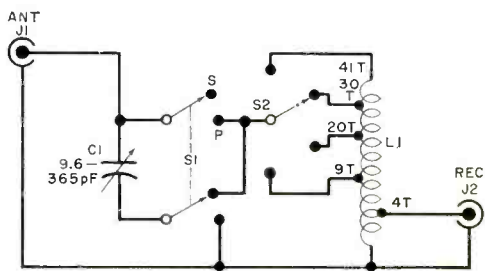

Circuit resonates at desired frequency and provides low-impedance output.

nectors ($J1$ and $J2$) may be conventional phono connectors or BNC-type devices.

The shaft of $C1$ must be cut down and an insulated extension shaft must be attached. This is because, when $S1$ is in the series mode, the capacitor shaft must be above ground. The shaft also reduces the effect of body capacitance. The capacitor and inductor can be mounted on a small piece of perf board with spacers to stand the assembly off the front panel. The insulated shaft should protrude through the front panel for tuning.

Inductor $L1$ consists of 41 turns of #26 enamelled wire covering $1\frac{1}{4}$ " of a $1\frac{1}{4}$ " diameter plastic form (possibly a plastic pill container), tapped at 4, 9, 20, and 30 turns. The first tap, at 4 turns, is used to feed $J2$.

To use the tuner, connect a random-length antenna to the center portion of $J1$ and the receiver to $J2$. Be sure a good ground exists between tuner and receiver and between receiver and ground.

Tune in a fairly strong station between 1.8 and 15 MHz and try each position of $S2$ with $S1$ in series and parallel. Tune $C1$ through its entire range until you notice a distinct increase in signal strength. Work your way across the various bands, adjusting the antenna tuner for a maximum signal at each point. Record each switch position with frequency for future use. ♦

DWELL/TACHOMETER INSTRUMENT

*Tune up your car
the professional way*

TO MAINTAIN the performance and smooth running of an internal combustion engine, it is necessary to recalibrate it or tune it at regular intervals.

One aspect of the tuning procedure requires that the gap between the contact breaker points in the primary circuit be within certain limits. There are two ways of doing this. The first is a static method which simply measures the gap between the points when they are fully opened; the second is a dynamic method and is more accurate since it relates point gap to dwell angle.

The dwell angle is the number of degrees rotated by the distributor rotor with the points closed.

Dwell Angle. A simplified primary ignition circuit for a 4-cylinder engine is shown in Fig. 1. When the contacts (or points) are closed, energy from the battery is stored in the ignition coil primary (in the form of a magnetic field). As the engine rotates, the distributor rotor pushes the contacts apart, thus breaking the circuit. The energy which was stored in the primary is now transferred to the secondary and the large emf produced is used to produce a spark across one of the 4 spark plugs.

A mechanical adjustment provided on the distributor can be used to alter the distance (or gap) between the point contacts when they are fully opened. Hence, the time during which the contacts remain closed will change as the gap is altered. For example, if the gap is increased, the contacts will remain open longer.

A dc voltmeter connected between the fixed contact and ground would indicate the average (area above equals area below) voltage value (e) of the waveform. Thus, the dc voltmeter can give an indication of the gap between the points. However as the gap is directly proportional to the time the points remain closed, the meter scale can also be calibrated to read dwell angle in degrees.

In the case of a 4-cylinder engine, the period is equivalent to one quarter of one complete cycle or 90° . Suppose the points always remained closed. In this case no voltage would be generated and zero deflection of the meter would correspond to 90° of dwell. If the points were closed for half a period, the meter would read $e = E/2$ giving 45° of dwell on the scale. Hence if E is known, the meter scale can be calibrated linearly in degrees of dwell. To obtain consistently accurate readings, it is essential that E remain constant when the instrument is used on different engines. This is obtained by connecting a shaping circuit between the distributor and the voltmeter. The shaping circuit also removes the

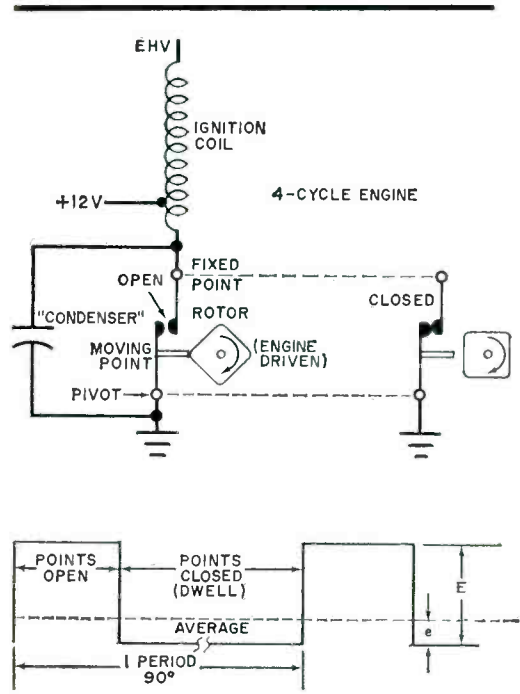

Fig. 1. Simplified ignition circuit and waveforms for a 4-cylinder engine.

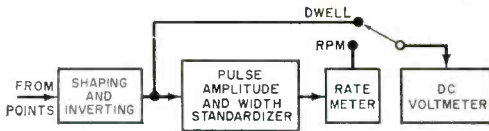

Fig. 2. Block diagram of the dwell-tachometer instrument. The voltmeter is switched to read dwell or rev/min.

large amount of ringing typically found in ignition circuits.

Note that the preceding also applies to 8- and 6-cylinder engines. In the case of an 8-cylinder engine the period would be equivalent to one eighth of one cycle or 45°. Hence if the same scale is used, zero deflection of the needle would indicate a dwell angle of 45°. For a 6-cylinder engine,

zero deflection corresponds to 60°. When the waveform of Fig. 1 is inverted, two advantages are immediately obtained: the meter scale is "reversed." (The 90-, 60-, or 45-degree markings are at full-scale deflection.) This means that a typical dwell indication will be in the upper third of the meter scale instead of in the first, hence greater meter accuracy; and, easier calibration of the instrument.

Engine Revolution. By counting the number of times the voltage *E* of Fig. 1 is generated per unit time, and taking into consideration the number of cylinders in the engine, the number of revolutions per minute (rpm) can be calculated. For example, in a 4-cylinder, 4-cycle engine, the points

Fig. 3. Schematic of the meter. Designed for negative ground systems, it tests 94% of US cars.

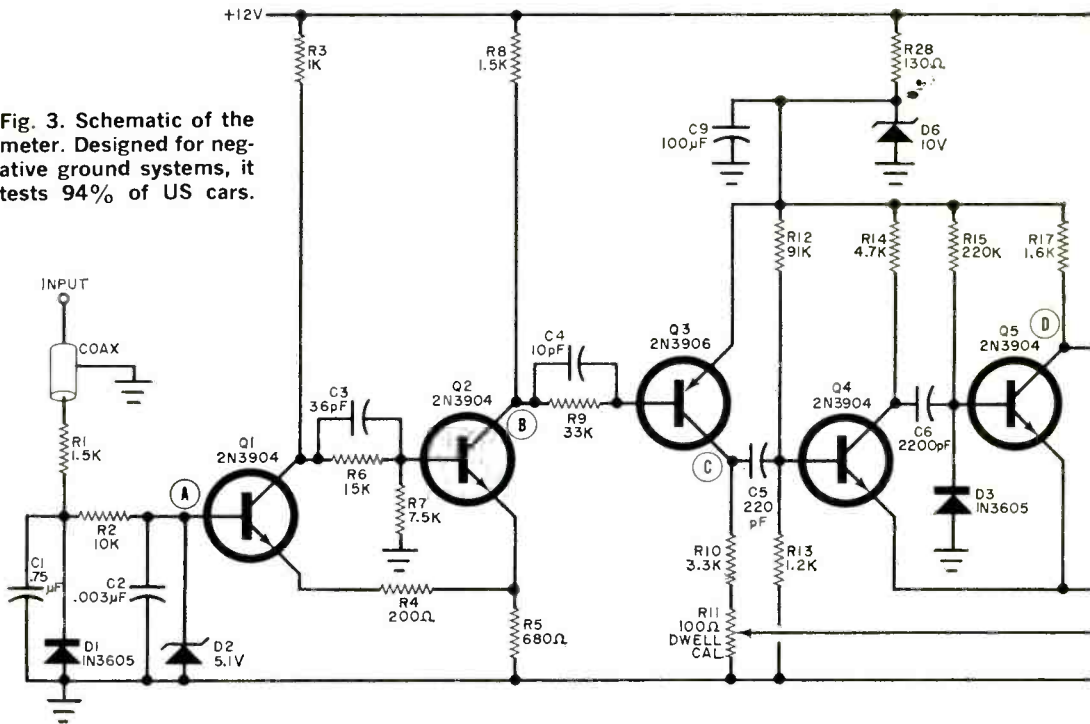

PARTS LIST

- C1—0.75- μ F capacitor
- C2—0.003- μ F capacitor
- C3—36-pF capacitor
- C4—10-pF capacitor
- C5—220-pF capacitor
- C6—2200-pF capacitor
- C7—(A) 62 pF, (B) 91 pF, (C) 120 pF (see text)
- C8—1- μ F, 25-volt electrolytic capacitor
- C9, C10—100- μ F, 25-volt electrolytic capacitor
- D1, D3, D4, D5—1N3605 diode

- D2—5.1-volt zener diode ($\frac{1}{4}$ M5.1Z or similar)
- D6—10-volt zener diode ($\frac{1}{4}$ M10Z or similar)
- M1—0-1 mA meter
- Q1, Q2, Q4, Q5, Q7, Q8—2N3904 transistor
- Q3—2N3906 transistor
- Q6, Q9—FET (MFE2097 or similar)
- R1, R8—1500-ohm, $\frac{1}{4}$ -watt resistor
- R2—10,000-ohm, $\frac{1}{4}$ -watt resistor
- R3—1000-ohm, $\frac{1}{4}$ -watt resistor
- R4—200-ohm, $\frac{1}{4}$ -watt resistor
- R5—680-ohm, $\frac{1}{4}$ -watt resistor
- R6—15,000-ohm, $\frac{1}{4}$ -watt resistor

open once (and hence produce 1 voltage pulse) for every two revolutions of the crankshaft. The same dc voltmeter can be used to measure engine rpm if a rate meter is connected between the meter and the shaping circuit thus becoming a "tachometer."

The block diagram of a combined dwell angle and tachometer instrument is shown in Fig. 2.

To obtain accurate rpm indications, the input pulses to the rate meter must have constant amplitude and constant width, hence the need for the pulse-width standardizer.

Circuit Details. The instrument to be described, and shown in Fig. 3, is designed

to operate with engines where the negative terminal of the battery is connected to ground. Over 94% of U.S. automobiles manufactured since 1956 fall into this category, while over 60% of imported cars also have negative ground electrical systems.

Converting the complex waveform from the distributor into a relatively clean one is accomplished by processes of limiting, integration and regeneration. Networks *R1C1* and *R2C2* form a pair of integrating networks. Diode *D1* removes most of the negative components of the waveform while zener diode *D2* limits the positive swing to 5.1 volts.

The double integration necessary to remove the ringing from the distributor waveform produces a rather slow-rising and even

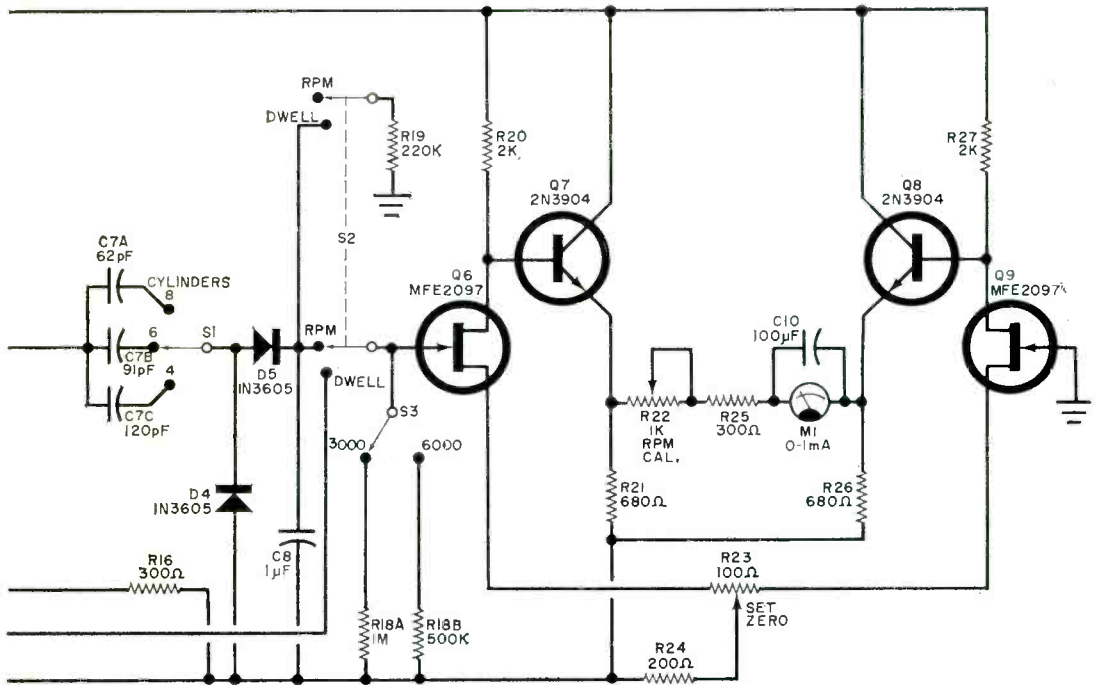

- R7—7500-ohm, 1/4-watt resistor
- R9—33,000-ohm, 1/4-watt resistor
- R10—3300-ohm, 1/4-watt resistor
- R11, R23—100-ohm trimmer potentiometer
- R12—91,000-ohm, 1/4-watt resistor
- R13—1200-ohm, 1/4-watt resistor
- R14—4700-ohm, 1/4-watt resistor
- R15, R19—220,000-ohm, 1/4-watt resistor
- R16, R25—300-ohm, 1/4-watt resistor
- R17—1600-ohm, 1/4-watt resistor
- R18—(A) 1 megohm, (B) 500,000-ohm, metal film, 1% resistor

- R20, R27—2000-ohm, 1/4-watt resistor
- R21, R26—680-ohm, 1/4-watt resistor
- R22—1000-ohm trimmer potentiometer
- R24—200-ohm, 1/4-watt resistor
- R28—130-ohm, 5%, 1/4-watt resistor
- S1—Single-pole, three-position rotary switch (see text)
- S2—Dpdt switch
- S3—Spdt switch (see text)
- Misc.—Suitable chassis, knobs, mounting hardware, etc.

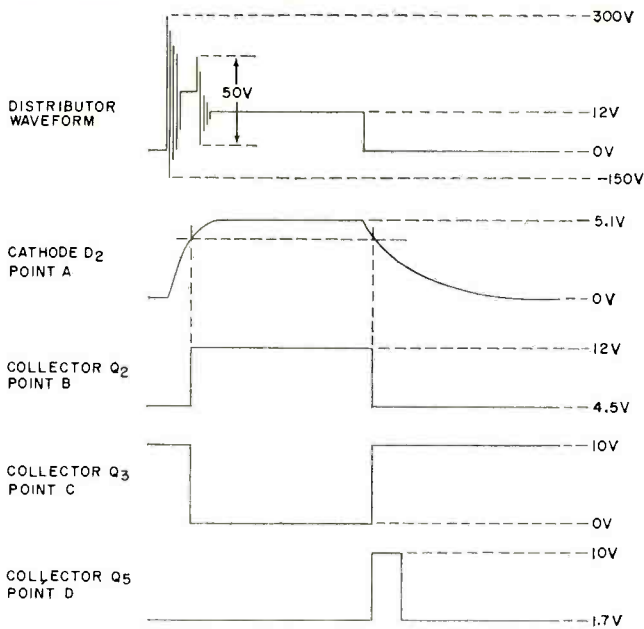

Fig. 4. Typical waveforms found on a 4-cylinder engine. To see ringing and steep rise times, a high-quality scope is needed.

slower-falling waveform as shown in Fig. 4. To overcome this, a waveform regenerator, or Schmitt trigger circuit, consisting of $Q1$ and $Q2$ and associated components is used; $Q1$ is normally off and $Q2$ on. The value of $R4$ is chosen to reduce the hysteresis gap to 0.4 volt. Transistor $Q1$ turns on when the voltage on its base reaches 4.2 volts and turns off again at 3.8 volts. The cut-in and cut-off levels chosen, together with the small hysteresis gap, produce a waveform at the collector of $Q2$ with the exact duty cycle of the distributor waveform. The rise time of the waveform at the collector of $Q2$ is 100 nanoseconds.

Transistor $Q3$ acts as an inverter driven either into saturation or cut off depending on the state of $Q2$, hence the excursions of the collector of $Q3$ are well defined. A fraction of the output from $Q3$ is tapped off by variable resistor $R11$ and sent to the meter circuit for dwell measurements. The full output from $Q3$ is differentiated by $C5$ and $R13$ to provide the trigger signal to switch on $Q4$.

The pulse width standardizer ($Q4$ and $Q5$) is a monostable multivibrator energized from a regulated supply.

Normally $Q4$ is off and $Q5$ conducting, $Q4$ being brought into conduction by the trailing edge of the waveform from the collector of $Q3$. The astable time of the

multivibrator is determined by $R15$ and $C6$. With the values shown, the output pulse has a width of 90 microseconds and an amplitude of 8.3 volts. Diode $D3$ protects the base-emitter junction of $Q5$ against reverse breakdown when $Q4$ comes into conduction.

The rate meter circuit consists of $C7$, $D4$, $D5$, $C8$ and $R18$. Each pulse from the monostable multivibrator dumps some charge into $C8$ via $C7$ and $D5$, thus a dc voltage builds up on $C8$ which is measured by the voltmeter. With the components shown in Fig. 3, a dc voltmeter having a sensitivity of 0.1 volt full scale, connected across $R18$, can be linearly calibrated to indicate RPM with a full-scale deflection of 3000. This assumes that the input resistance of the voltmeter is considerably higher than the value of $R18$. If more than one rpm scale is required, a switch ($S3$) can be connected as shown in the diagram to introduce different values of $R18$ into the circuit. Another switch ($S1$) can also be used to select different values of $C7$ so that the same rpm scales can be used for 4-, 6-, or 8-cylinder engines.

The dc voltmeter consists of FET differential amplifier $Q6$ and $Q9$ and provides the necessary high input resistance to avoid loading the rate meter. A pair of emitter followers, $Q7$ and $Q8$, provide the low

impedance necessary to drive meter *M1*. The FET's and associated transistors should be placed physically close to each other to achieve optimum temperature compensation. The gain of the differential pair is approximately 10 and *R23* is used to balance the currents in the two halves of the circuit to produce zero meter deflection for zero volts input. Potentiometer *R22* is adjusted to calibrate the rpm scales while *C10* is used to smooth the meter needle fluctuations when measuring dwell angle at low rpm.

The regulated power supply enables the instrument to operate directly from the engine's 12-volt battery. Zener diode *D6* acts as a 10-volt regulating element providing the necessary constant supply voltage for *Q3*, *Q4* and *Q5*, thus making the accuracy of the instrument independent of normal battery voltage fluctuations.

Construction. Almost any type of construction may be used, PC or perf board. Remember that vibration comes into play during automotive use, so take appropriate care in mounting components. In the prototype, a 4" by 2½" board having plated-through holes 0.3" apart was used. All components except the switches and meter were mounted on the single board. The overall size of the project is determined by the meter used.

If the instrument is to be used on only one type of vehicle (say 8 cylinders), then *S1* can be eliminated and the required value of *C7* is used. If only one rpm range is needed, then *S3* can be eliminated after selection of appropriate *R18*. The only switch actually on the front panel will then be rpm/dwell selector *S2*.

The only critical components are the capacitors selected for use as *C7*. These must be of high quality, therefore silver mica or polystyrene capacitors are used.

Another item worth special mention is the meter. Electrically, it must have a full-scale deflection of not more than 1 mA to give the correct indications with the values shown in the diagram. Of course, if a more sensitive meter is available, it can be used provided the values of *R22* and *R25* are changed to match the full-scale deflection. The physical shape and size of the meter are not critical, they depend on individual preference or on what is available. However, because the meter is the bulkiest item in the instrument, it should be chosen

first as it will determine the cabinet size. Always keep in mind that the meter does undergo some physical vibration in use, so a taut-band type is preferred. Another word is in order regarding the meter scales. Preferably there should be two linear scales, say 0-1 and 0-3. The 0-1 scale is used with a $\times 100$ factor to give 0-100 degrees dwell. The 0-3 scale is used with either a " $\times 1000$ " or " $\times 2000$ " factor to provide the 0-3000 and 0-6000 rpm readings. Readers with a steady hand may want to open their meters and mark their own scales.

Waveforms. The waveforms shown in Fig. 4 will be found useful when troubleshooting the circuit. They were observed with a 50-MHz oscilloscope using a 10-megohm, 7-pF probe. The amplitudes given for the distributor waveform are approximate since they vary with different types and makes of engines. The distributor ringing waveshape shown is fairly typical for all engines. Note that the amplitude and width of the pulses appearing at the collector of *Q5* are independent of engine characteristics and performance; only the number of these pulses per unit time is significant.

Calibration. Only two adjustments are required to calibrate the instrument after completion. The component values used in Fig. 3 will provide two rpm scales, 0-3000 and 0-6000. Should different full-scale ranges be desired, the values of *R18A* and *R18B* can be determined empirically. A sine wave generator capable of delivering at least 15 volts peak or a square wave generator capable of delivering at least 12 volts peak is necessary. If the frequency of the generator is not known accurately, a frequency counter will also be needed.

Connect the dwell/tach to a source of about 14 volts dc; switch to the rpm mode and connect the output of the audio generator to the input of the instrument. Adjust the audio generator amplitude for either 15 or 12 volts peak and the frequency to 100 Hz. This frequency corresponds to 3000 rpm and, for 4-cylinder engines, is equal to twice the full scale rpm desired divided by 60. Adjust *R23* to obtain full scale deflection.

For dwell calibration, disconnect the audio generator from the instrument, switch *S2* to "dwell" mode. Meter should now indicate full scale. If not, adjust *R11* to obtain an exact full-scale deflection. ♦

Versatile IC Timer

*From 10 microseconds to 1000 seconds
using one IC and four components*

BY WALTER W. SCHOPP

THERE are timers that are initiated by the closing of a switch and there are timers whose cycles are started by the opening of a switch. There are circuits that energize a relay to close contacts and circuits to de-energize a relay—sometimes during the same timing cycle. Described here are circuits that perform many of these basic timing functions, all using a low-cost easy-to-apply integrated circuit. Some of the circuits are operated by switches, some by touch plates. In all cases, once the cycle has been started the timing can not be affected by further

triggering until the cycle has been completed.

The integrated circuit is a Signetics type 555. It is available from suppliers such as Poly-Paks, Solid-States Sales, etc. The power supply for the timers can be obtained from a battery or an unregulated supply of 10 to 18 volts.

The accuracy of most timing circuits is affected by voltage variations in the supply because the charging rate of the timing capacitor varies with respect to the fixed trigger point of the device (transistor or FET) used

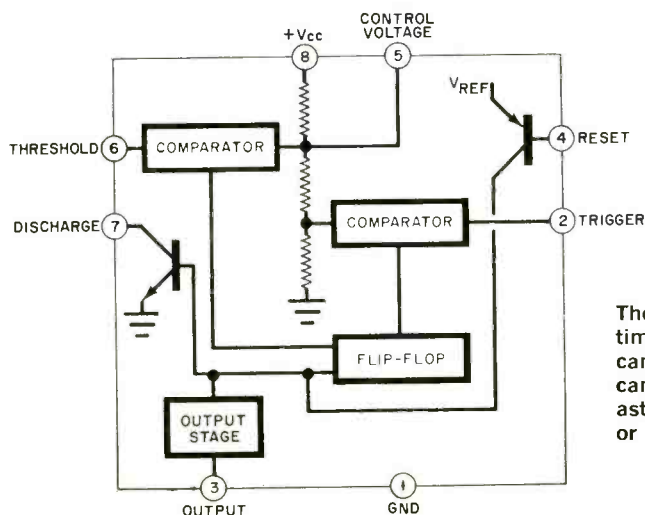

The internal circuitry of the 555 timer IC. Besides timing, the IC can be used as an oscillator and can operate in both monostable and astable modes. The output can sink or source 200 mA or drive TTL.

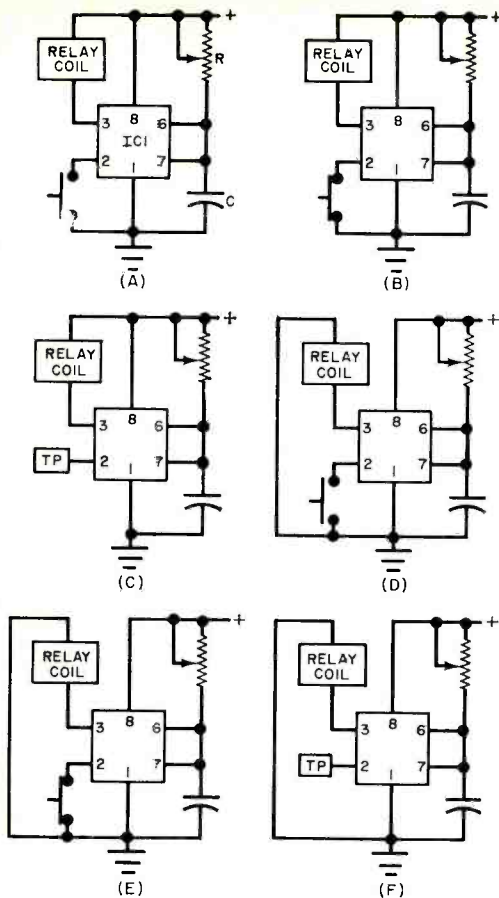

Typical timing circuits: (A) Relay normally energized. Time cycle initiated by closing normally open switch. Relay de-energized during time cycle. (B) Relay normally energized. Time cycle initiated by opening normally closed switch. Relay de-energized during time cycle. (C) Relay normally energized. Time cycle initiated by contact on touch plate. Relay de-energized during time cycle. (D) Relay normally de-energized. Time cycle initiated by closing a normally open switch. Relay energized during time cycle. (E) Relay normally de-energized. Timing initiated by opening switch. Relay energized during time cycle. (F) Relay normally de-energized. Time cycle initiated by touch plate. Relay energized during time cycle.

at the input of the timer. In the circuits presented here, the charging rate of the timing capacitor and the threshold trigger point of the comparator are both directly proportional to the supply voltage. This means that the power supply voltage has little effect on the timing accuracy.

Timing cycles varying from microseconds to hours can be obtained by changing the time constant of the resistor/capacitor circuit. The chart shows the values to use for R and C for different time delays.

The relay used in these circuits can be any low-current sensitive relay such as Sigma 4F-5000 or 11F-2300-G-SIL. ♦

Required R and C for timing intervals from 10 microseconds to 1000 seconds.

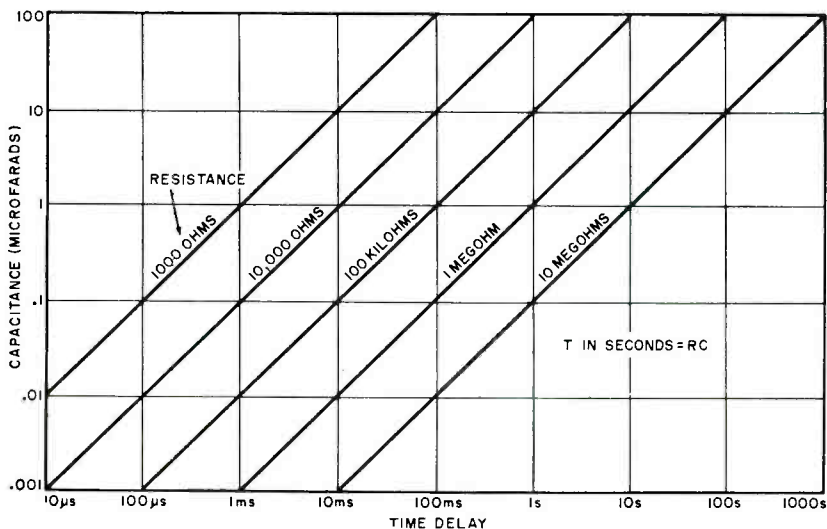



BY LEWIS J. NEWMIRE

BUILD THE

DECID-O-TRON

LET ELECTRONICS HELP YOU MAKE DECISIONS

EVEN top-flight executives sometimes have trouble making decisions. If they don't have a flippable silver dollar handy—or a solid-state Ouija board with alpha-

numeric readout—they just may need a "Decid-O-Tron." This battery-powered device can be used any time or any place to help the undecided take the fatal step.

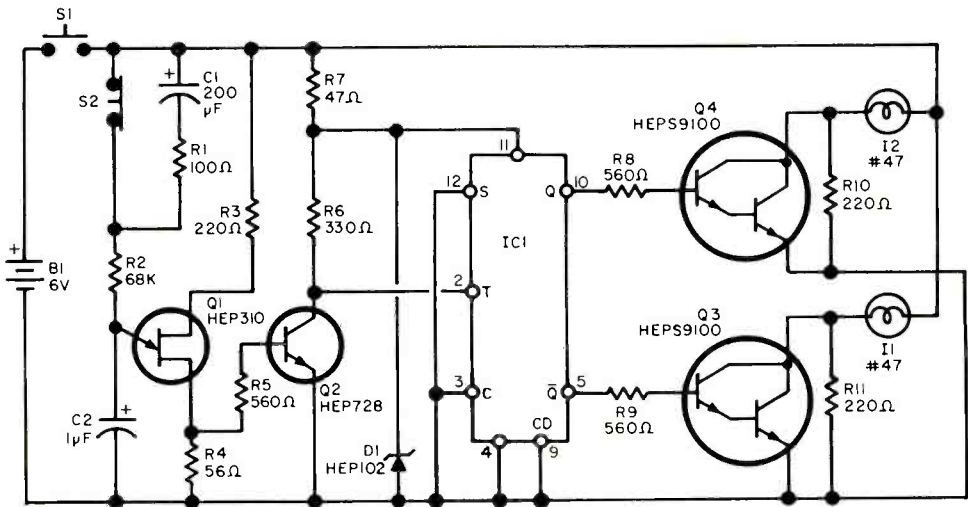

PARTS LIST

- B1—1.5-volt C cell (4 needed)
- C1—200- μ F, 15-volt electrolytic capacitor
- C2—1- μ F, 50-volt electrolytic capacitor
- D1—3.6-volt zener diode (HEP102)
- I1, I2—#47 lamp
- IC1—RTL JK flip-flop (Motorola MC-723P)
- Q1—Unijunction transistor (HEP310, 2N2160)
- Q2—Transistor (HEP728)
- Q3, Q4—Dual transistor (HEPS9100)
- R1—100-ohm, $\frac{1}{4}$ -watt, 10% resistor
- R2—68,000-ohm, $\frac{1}{4}$ -watt, 10% resistor

- R3, R10, R11—220-ohm, $\frac{1}{4}$ -watt, 10% resistor
- R4—56-ohm, $\frac{1}{4}$ -watt, 10% resistor
- R5, R8, R9—560-ohm, $\frac{1}{4}$ -watt, 10% resistor
- R6—330-ohm, $\frac{1}{4}$ -watt, 10% resistor
- R7—47-ohm, $\frac{1}{4}$ -watt, 10% resistor
- S1—Spst normally open pushbutton switch (black)
- S2—Spst normally closed pushbutton switch (red)
- Misc.—Suitable chassis (Harry Davis 260) with cover, battery holders, lamp socket with lens (one red, one green,) mounting hardware, etc.

Fig. 1. Decisions are made by random toggling of flip-flop through operation of S2.

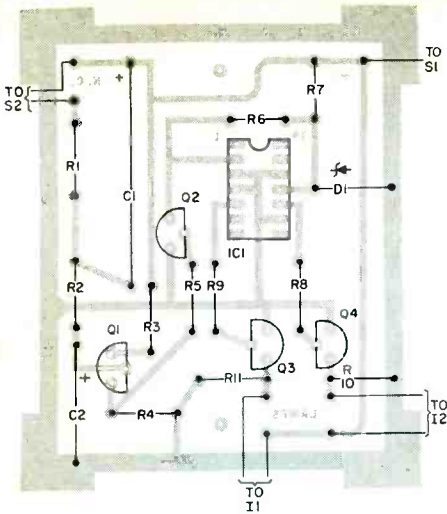
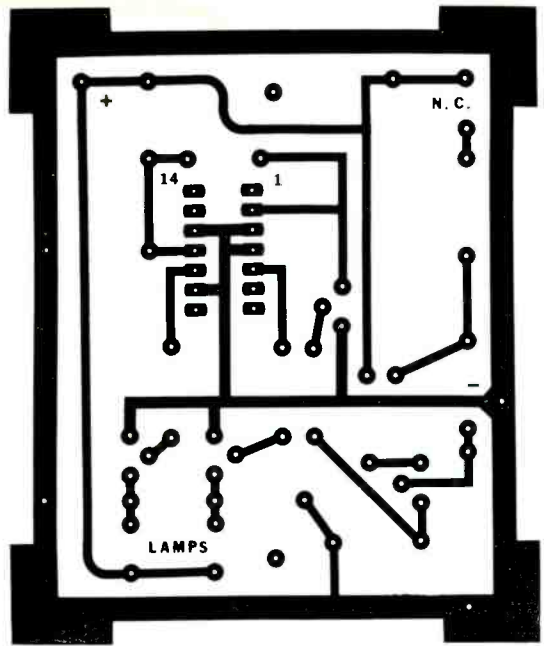

Fig. 2. Actual size foil pattern (at right) and component layout (above). Observe polarities on semiconductors.



How It Works. The heart of the circuit (Fig. 1) is *IC1*, a JK flip-flop whose outputs can be in one of two stable states: high or low. Each output controls a lamp driver (*Q3* or *Q4*) and since only one flip-flop output is positive at any one time, only one lamp can be lit at one time.

With pushbutton switch *S1* closed, UJT *Q1* operates as a conventional relaxation oscillator. This signal drives *Q2* into saturation, causing its collector voltage to drop at each pulse applied to its base. This negative-going pulse toggles the flip-flop.

If *S1* is kept closed, and pushbutton switch *S2* is opened, capacitor *C1* starts to charge up and the voltage across *R2* is reduced. This lowers the charging current for timing capacitor *C2* and reduces the frequency of oscillation to the point where it stops. This is what provides the "decision."

Resistors *R10* and *R11* are used to reduce the stress on *Q3* and *Q4* and the filaments of *I1* and *I2*. This is necessary since the lamps have high inrush currents when cold; resistors limit current to about 20 mA.

Construction. Although any type of construction can be used, the best method is to fabricate a PC board using the foil pattern and component layout shown in Fig. 2.

Mount the board in a suitable chassis with the lights and pushbutton switches on the front panel as shown in the photograph

of the prototype. Use different colored lenses for lamps and pushbuttons.

The battery holders are mounted in the bottom of the chassis with short lengths of insulated wire to connect the PC board to the other components.

Operation. With *S1* depressed for some short interval of time, the two lamps should alternate. In this mode, the circuit is unable to make a decision. With *S1* still depressed, press *S2*. After a few moments, the two lamps will alternate slower and slower until, finally, only one lamp remains lit.

Is the output random? We asked the Decid-O-Tron that very question; and 50% of the time it said, "Yes." ♦

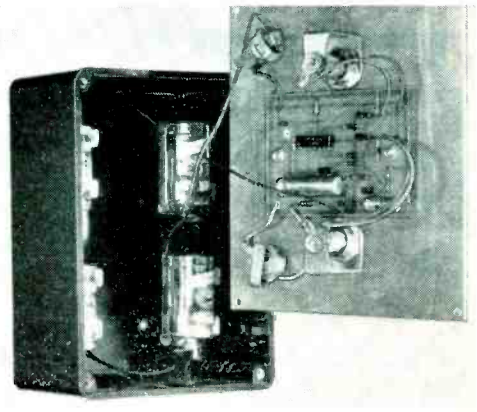

NOW...

understanding
more about music
can be as easy
as listening
to your
favorite
recordings.

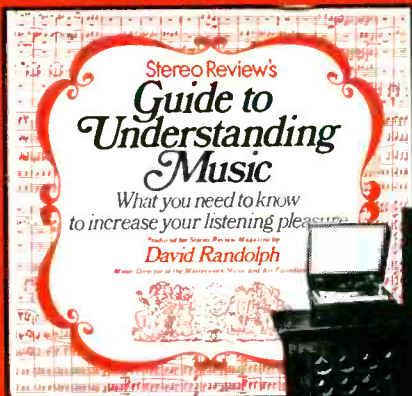

Stereo Review is proud to announce an important new set of recordings created to help you expand your understanding of music.

This unique four-disc album is interesting, easy to comprehend, and instructive. It is the first project of its kind to approach the understanding of music through its basic elements:

rhythm...melody...harmony...texture

If you have wanted to know more about music — or simply to enjoy it more — Stereo Review's GUIDE TO UNDERSTANDING MUSIC will be the most rewarding step you can take in that direction.

Written and narrated exclusively for Stereo Review by David Randolph, Music Director of the Masterwork Music and Art Foundation, this fascinating set of stereo records will help you become a more sophisticated, more knowledgeable listener — and a more completely satisfied one as well. It will give you an "ear" for music you never thought you had.

In the GUIDE TO UNDERSTANDING MUSIC, David Randolph first discusses, by means of recorded narration, how the composer uses and unites all the basic musical elements. After each musical point is made in the narration, a musical demonstration of the point under discussion is provided. Thus you become a part of the creative musical process by listening, by understanding, by seeing how music's "raw materials" are employed by composers and performers to attain their highest level of expressivity and communication through musical form.

FOUR LONG-PLAY STEREO RECORDS

- Record I** — The Elements of Music
1. Rhythm 3. Harmony
2. Melody 4. Texture
- Record II** — Sense and Sensation in Music
(The Instruments of the Orchestra)
How Music Is Unified
- Record III** — Form in Music
Words and Music
- Record IV** — Can Music Tell a Story or Paint a Picture?
The Interpretation of Music

The GUIDE TO UNDERSTANDING MUSIC contains **OVER 200 MUSICAL EXAMPLES** which have been carefully chosen from among thousands of recordings by major record companies as the best illustrations of musical points made in the recorded narration. In addition, supplementary musical demonstrations were specially recorded for this album.

FREE BOOKLET INCLUDED

The accompanying booklet is a valuable complement to the album. It presents David Randolph's straightforward professional approach to music, and shares the insights and understanding of his many years of experience in bringing music to

listeners... as well as advice on how you can make the best use of the album.

If you already have some knowledge of music, the *Guide to Understanding Music* can expand and enrich that knowledge. If you've always wanted to understand music but have been discouraged because it looked too difficult and time-consuming, the *Guide to Understanding Music* can show you how easily and quickly you can make yourself at home with any music.

First Time Ever Offered

The *Guide to Understanding Music* has been several years in the planning and production stages to assure that it would be as complete, as up-to-date, and as effective a presentation of its subject as possible. The exclusive four-disc recording is now ready, available for the first time through Stereo Review. The special low price is just \$19.98, postpaid, for all four 33 $\frac{1}{3}$ rpm stereo long-play records, a price made possible by the availability of the consultative and production facilities of Stereo Review and its staff. Under ordinary auspices, a work of this nature and importance would cost much more.

Records, Ziff-Davis Service Division \$95 Broadway, New York, N.Y. 10012. EEH-W-75

Yes, I want to enrich my musical background:

- Please send the *Guide To Understanding Music* @ \$19.98 postpaid.
 Please send _____ (3 or more) *Guide To Understanding Music* @ \$17.98 per album, postpaid.

My check (or money order) for \$ _____ is enclosed.

CHARGE: American Express BankAmericard



Account # _____ Address _____

Signature _____ City _____

Print Name _____ State _____ Zip _____

ENCLOSE PAYMENT WITH ORDER IF NOT CHARGED

SPECIAL SCHOOL AND LIBRARY OFFER

Of particular importance is the role the GUIDE TO UNDERSTANDING MUSIC can play as a teaching tool for music departments in schools throughout the country. Orders for 3 sets or more are available to schools and libraries at the SPECIAL DISCOUNT PRICE of only \$17.98 per album, a savings of 10% of the regular price of \$19.98. This special quantity price is also available to individuals and organizations who may have a need for more than one album. Schools may submit orders on standard purchasing forms. Individuals and organizations are requested to use the coupon on this page and enclose payment with order.

VEHICLE ALARM SYSTEM

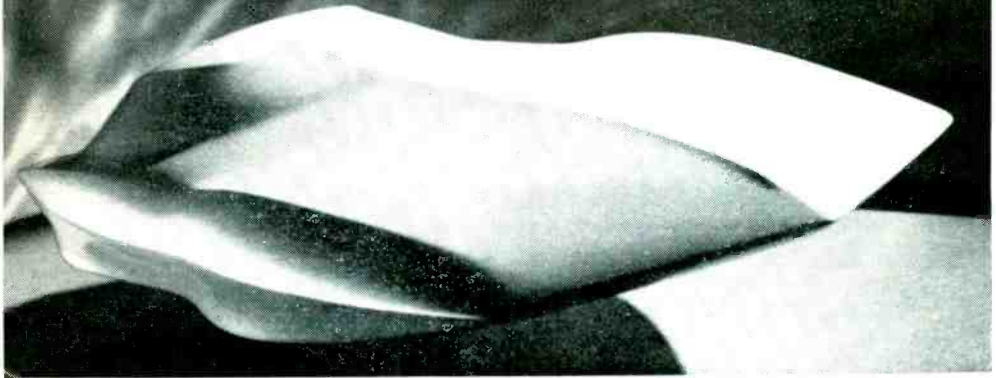

KEYLESS SYSTEM OFFERS THREE OPERATIONAL MODES

BY FRANK J. DIELSI

WITH automobile thefts increasing—in spite of the best efforts of Detroit in providing locking steering columns and buzzer warning systems on the ignition—it is apparent that a reliable alarm system is necessary to protect not only the vehicle but its contents as well.

Most available alarm systems require the installation of an outside "pick proof" lock with an additional key that has to be carried around and separate switches installed at each door, the trunk, and the hood. Unfortunately, many of these systems are still vulnerable because the vehicle battery can be disconnected simply by reaching under the car and cutting the cable.

The alarm system described here eliminates all of these problems. It is operated by the switch on the door which turns on the dome light or by switches on the hood and trunk if present. Installation is very simple since only one wire of the car's electrical systems has to be modified. The

alarm has a self-contained battery that is continuously trickle-charged; and the arming switch can be hidden in any convenient location in the car. When armed, the alarm disables all other electrical systems in the car including the starter, ignition, and lights; but it does not draw any current until triggered. To prevent triggering the alarm by the driver, an adjustable 3- to 8-second time delay is used, allowing ample time to arm the system before leaving the car and disarm it upon returning. It would take much longer than that for an intruder to analyze the system and find the switch—even if he knew that the car was protected by an alarm.

The driver also has the option of 3 modes of siren operation to suit different situations. In mode A, when the door, hood, or trunk is opened, after the initial delay, the siren sounds for 60 seconds and then goes on and off at approximately 7-second intervals until the door is closed, the arming

switch is turned off, or the batteries are exhausted. If the door is closed after the siren starts, it sounds for 60 seconds only and then stops and is ready to sound again when a new threat occurs.

In mode B, after the initial delay, the siren sounds for 60 seconds only and then stops whether the door remains open or is

closed. If the door is closed, the alarm resets. This mode is suitable for parking in crowded areas where a 60-second siren is sufficient to frighten off an intruder without creating excessive noise.

In mode C, after the initial delay, the siren sounds continuously until the arming switch is turned off or the batteries are exhausted, whether the door remains open or closed. If the owner is within hearing range, mode C can be used.

How It Works. The system (see Fig. 1) was designed for use with a negative-ground battery system, but it can be changed for use with a positive ground by reversing the polarities of all the diodes and the auxiliary battery.

Thermostatic relays are used because they are simple and inexpensive. They are temperature compensated and unaffected by mechanical vibrations.

When the arming switch (S1) is on and a door is opened, the current from the car battery will flow to terminal 1 through F1, D1, K1 heater, D4, and the variable time-delay control, R1, to terminal 2 where the circuit is through the normal vehicle wiring of the dome light and door switch to ground. If the car battery is disconnected, the current will be supplied by the auxiliary battery through F2 and D3. Most of the battery voltage of this series circuit will appear across the heater element of K1 because it has a much higher resistance of about 70 ohms in relation to about 2 ohms cold resistance of the dome light. After the delay interval, the normally open contacts of K1 close and K2 is energized. Relay K2 locks in through one set of contacts and supplies voltage to the siren through the other set. If terminal 6 is connected to 5 (mode A) the heater of K3 is energized. After 60 seconds, the contacts of K3 open to de-energize K2, turning off the siren and the heater of K3. When the heater of K3 cools (about 7 seconds), its contacts close, energizing K2, the siren and K3's heater. Since the heater hadn't completely cooled, the contacts will again open in about 7 seconds. This cycle continues until the door is closed to turn off K1. Relay K2 remains locked in until the contacts of K3 open to reset alarm.

In mode B, terminals 6 and 7 are connected together. After K1 and K2 are energized, K3 will operate after 60 seconds to de-energize K2. If K1 is still on, the K3

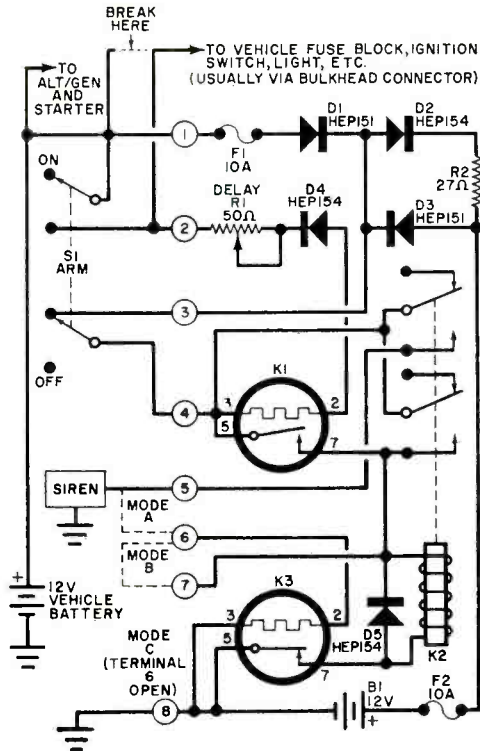

PARTS LIST

- B1—Eight rechargeable alkaline D cells
- D1, D3—HEP151 diode
- D2, D4, D5—11EP154 diode
- F1, F2—10A, 3AG fuse and holder
- K1—12V, normally open, 2-second delay thermostatic relay (Amperite 12NO2)
- K2—Dpdt, 12V dc relay (Line MK02D or similar)
- K3—12V, normally closed, 60-second delay thermostatic relay (Amperite 2C60)
- R1—50-ohm, 2-watt potentiometer (Ohmite CLU5001 or similar)
- R2—27-ohm, 2-watt resistor
- S1—Dpdt, 20A slide or toggle switch
- Misc.—Battery holders, suitable chassis (Bud CU729HG or similar), octal sockets for K1 and K3, 8-terminal barrier strip, 12-volt siren, mounting hardware, wire, etc.

Fig. 1. Alarm system has three modes of operation for different parking situations. Connection to vehicle's system is shown by the broken line.

Fig. 2. Circuit can be mounted in any enclosure which will fit conveniently in vehicle. The arrangement shown here used 4 x 5 x 6 in. box. Hide the unit as carefully as possible and try to conceal wiring.

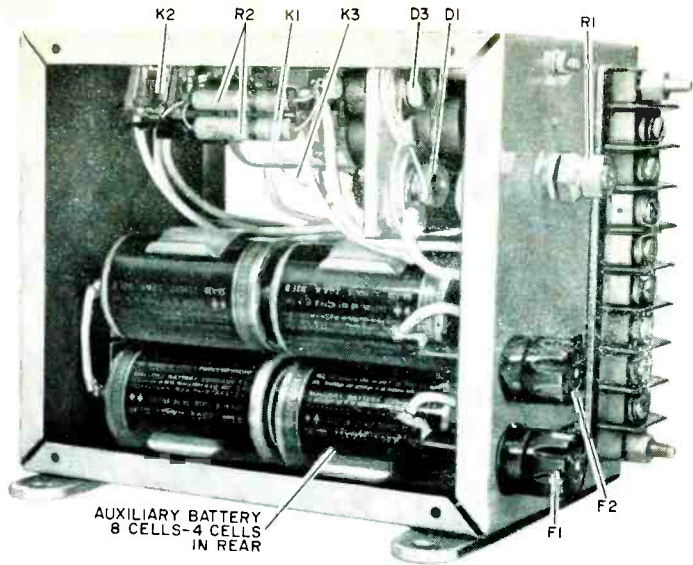

heater will stay on, keeping *K2* and the siren off. If the door is closed, the *K1* contacts open but *K2* is locked in until the 60-second delay of *K3* is completed. Then *K2* is de-energized and the alarm is reset.

In mode C, *K3* is never energized so that once *K1* is energized, *K2* locks in and the siren sounds continuously.

Diode *D1* prevents the auxiliary battery from discharging into the car's electrical system when the car's battery voltage is below that of the auxiliary battery (during cranking interval). Diode *D3* protects the auxiliary battery from overcharge while *D4* keeps the car battery from holding *K1* closed after the arming switch is turned off. Diode *D5* protects contacts of *K3* from inductive surge when *K2* is de-energized.

The eight rechargeable D cells in the auxiliary battery can operate a 4-ampere siren for about 15 minutes and should have a useful life of at least 50 discharge-charge cycles. The charging circuit through *R2* limits the charge current to 150 mA with an alternator voltage of 14.5 volts and auxiliary battery voltage of 8.8 volts. When the auxiliary battery is charged up to 12 volts, the trickle current from the alternator is limited to about 35 mA. The fully charged auxiliary battery does not draw any current from the car's battery because the 0.6-volt difference between the batteries is less than the 1.5-volt drop across *D1* and *D2*. At 8.8 volts, the auxiliary battery will charge at about 80 mA from the car's battery.

Construction. The complete unit, including the 8-cell auxiliary battery can be enclosed in a 4" x 5" x 6" box as shown in Fig. 2. The layout is not critical and can be changed to suit the space and mounting conditions of the car. The two stud-mounted diodes (*D1* and *D3*) are mounted with insulating washers on a 1/8-inch aluminum panel that also holds the sockets for relays *K1* and *K3*. Switch *S1* should be connected to terminals 1 and 2 with No. 12 (or larger) wire and to terminals 3 and 4 with No. 16 wire.

Installation. Hide the alarm unit as well as possible and disguise the wiring so that it looks like normal car wiring. The original car horns are not recommended for the alarm because their location makes them very vulnerable. Two small sirens can possibly be hidden in different locations instead of one large siren.

To test the auxiliary battery, remove fuse *F1* and turn on the alarm with the door open.

The only part of the car's normal wiring that has to be changed is the single wire that connects the battery to the headlight switch, ignition switch and fuse block. This wire can usually be found at the bulkhead connector or tie point on the horn relay. The normal connections to the alternator voltage regulator and starter solenoid should remain on the battery side of the alarm system. ♦

Design Your Own Color Organ

PICK YOUR OWN CHANNEL FREQUENCIES USING THIS SIMPLE DESIGN METHOD

BY DARYL SLAVIERO

CHANGING colored lights that keep time with the music—the color organ—are a natural accompaniment for a good stereo system. The possibilities are even greater with the newest quadraphonic systems—surround sound and surround light!

There are many types of multi-lamp color organs, ranging from simple LC or RC passive filter circuits to active filters driving SCR's or triacs. The passive filter is the less expensive but consumes audio power. Active filter circuits are preferable but they are often costly. They need not be, however, if you use the simplified circuit design

described here. If new parts are used in this design, a three-channel color organ should cost less than \$30. It will be less if some of the parts are available in the junk box.

How It Works. The circuit shown in Fig. 1 is for one channel only. Simplified design information will be given to add any number of channels for any center frequency within the audio range by changing three capacitors and adjusting a potentiometer.

The audio input signal is coupled to the color system through transformer *T1* and drives transistor *Q1*, a frequency selective amplifier. The amplitude of the output of this stage depends on the input frequency, if the input amplitude is held constant. However, the higher the input level is set (by *R1*), the more often the channel lamp will come on.

The output of *Q1* drives an SCR (or triac) through *Q2* which is used to buffer the output of *Q1* from the relatively high load of the SCR. Thus, although about 10 mA may be required to drive the SCR, only about 0.1 mA is required at the input to *Q2*. The SCR is turned off by using ac as the supply. Each time the ac voltage passes through zero, the SCR turns off and waits for the next trigger signal from *Q2*.

FILTER CALCULATIONS

Assume for *Q1*: $V_{CE} = 10 \text{ V}$, $I_C = 3 \text{ mA}$,
 $V_{CC} = 20 \text{ V}$, $\beta = 100$.

$$R4 = (V_{CC} - V_{CE}) / I_C = (20 - 10) / 0.003 \\ = 3333 \text{ ohms (use 3.3 kilohms)}$$

$$R3 = (V_{CE} - 0.6) / (I_C / 100) \\ = 9.4(100) / 0.003 = 313,333 \text{ ohms} \\ \text{(use 330 kilohms)}$$

$$C1, C2, C3 = 20 / f \\ = 20 / 80 = 0.25 \mu\text{F} \\ = 20 / 400 = 0.05 \mu\text{F} \\ = 20 / 1000 = 0.02 \mu\text{F} \\ = 20 / 4000 = 0.005 \mu\text{F}$$

Fig. 1. Active filter (Q1) is buffered by Q2 and drives the SCR to energize lamp connected to socket.

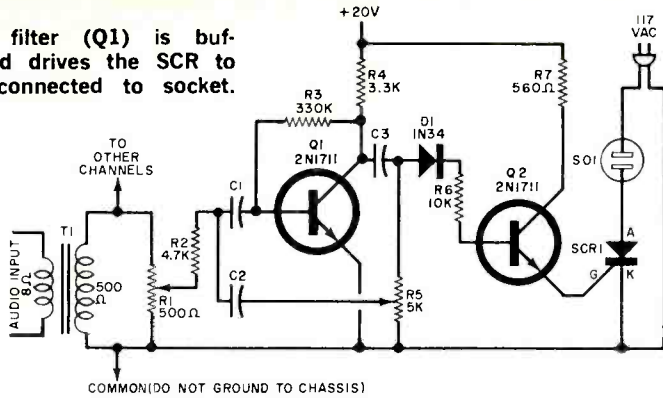

PARTS LIST

- C1-C3—See text
- D1—Small-signal diode (1N34 or similar)
- Q1-Q2—2N1711 transistor (see text)
- R1—500-ohm linear potentiometer
- R2—4700-ohm resistor
- R3—330,000-ohm resistor (see text)
- R4—3300-ohm resistor (see text)

- R5—5000-ohm linear taper potentiometer
- R6—10,000-ohm resistor
- R7—560-ohm resistor
- SCR1—2.5 amperes, 200 PIV (see text)
- SO1—117-volt panel receptacle
- T1—Audio transformer: 8/500 ohms
- Misc.—Suitable chassis, terminal strips, knob for R1, mounting hardware, etc.

Circuit Design. Almost any npn transistor can be used for Q1 and Q2 as long as the one for Q1 has a minimum beta of 50 and for Q2 a minimum beta of 100. The SCR should have sufficient power rating to operate the lamps to be used. If lamps with voltage ratings other than line voltage are used, the rating of the SCR may have to be changed. For very large loads, transistor Q2 should have a high output and R6 and R7 may have to be decreased in value to provide the extra drive.

Simplified calculations for the important elements of the active filter are shown in the box. Calculations for R3 and R4 are used if a transistor other than the 2N1711 is used. These equations also show a simple method of calculating the required value of the filter capacitors (C1, C2, and C3). The examples shown are for 80 Hz, 400 Hz, 1 kHz and 4 kHz, though any other center frequency can be selected. A typical 20-volt power supply is shown in Fig. 2.

Operation. For each stage of the color organ (as shown in Fig. 1.), when power is applied but without an input signal, potentiometer R5 is adjusted until the filter just starts to oscillate and the associated lamp is turned on. Then R5 is backed down until the lamp goes off. If desired, once the correct setting of R5 has been determined, the resistance values measured from the rotor to the ends can be used to determine fixed resistors to substitute for the potentiometer.

The channel is then fed a signal from the 8-ohm output of an audio amplifier.

If very high volume is required from the speaker, insert a resistance between 47 and 100 ohms in series with the input of T1 to remove the distorting effects of saturation of the transformer.

Lamp Power. If 117-volt line power is used for the lamps, an isolation transformer of the necessary wattage is suggested to prevent accidental shocks. In units such as this, where the power is ac, it is always best not to use a metal chassis; but if you do, make sure that all wiring is connected to insulated lugs of terminal strips. Under no conditions should the metal chassis be used as a common return.

If low-voltage lamps are used, a suitable heavy-duty filament transformer is ideal. Make sure that the total lamp wattage does not exceed the ratings of the SCR (or triac) and the transformer. ♦

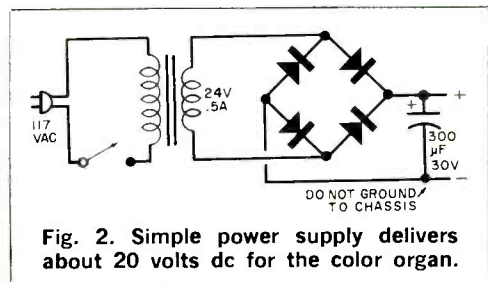

Fig. 2. Simple power supply delivers about 20 volts dc for the color organ.

BUILD A COSMOS DIE

BY MICHAEL S. ROBBINS

Learn to use this latest extremely low-power logic

WHERE power supply requirements are concerned, today's digital integrated circuits are amazingly economical. For example, RTL gates use 3.6 volts with each gate requiring about 13 mA; DTL gates use a 5-volt supply and require about 4 mA per gate; and TTL uses 5 volts at 5 mA per gate. The new COSMOS gates, however, require only 0.02 microampere at 5 volts and can operate between 3 and 15 volts.

COSMOS is an acronym for complementary-symmetry metal-oxide semiconductor. RCA actually calls their units COS/MOS, while Motorola calls theirs MCMOS. The technology involved is an outgrowth of that used to produce the more familiar metal-oxide field-effect transistor (MOSFET).

Besides taking very little power, the individual COSMOS elements are so small that more of these devices can be packed on a single chip than conventional bipolar devices. As an example, consider the complexity of a whole calculator on one chip or a complete clock on a single chip. One standard COSMOS device, the RCA CD4020AE, contains 14 flip-flops and, with a 16.384-kHz input, will divide down to 1 Hz. Power consumption of this chip is less than 0.5 mA at 5 volts.

Electronic experimenters will want to work with COSMOS units to get to know how they operate and learn some of their many uses. One way to get started is to build the random-digit generator shown in Fig. 1. To make the project more interesting, this circuit forms the equivalent of a six-sided die by randomly displaying digits 1 through 6 on a small seven-segment LED readout. Two COSMOS IC's and a single bipolar transistor are the only active elements.

Circuit Operation. The 15-kHz oscillator drives a single-chip counter-driver which ordinarily would indicate from 0 to 9. However, at the seventh input pulse (which would attempt to cause the LED readout to go from 6 to 7), a reset pulse is gener-

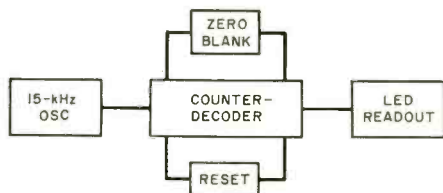

Fig. 1. Circuit includes a 15-kHz oscillator driving a counter-decoder.

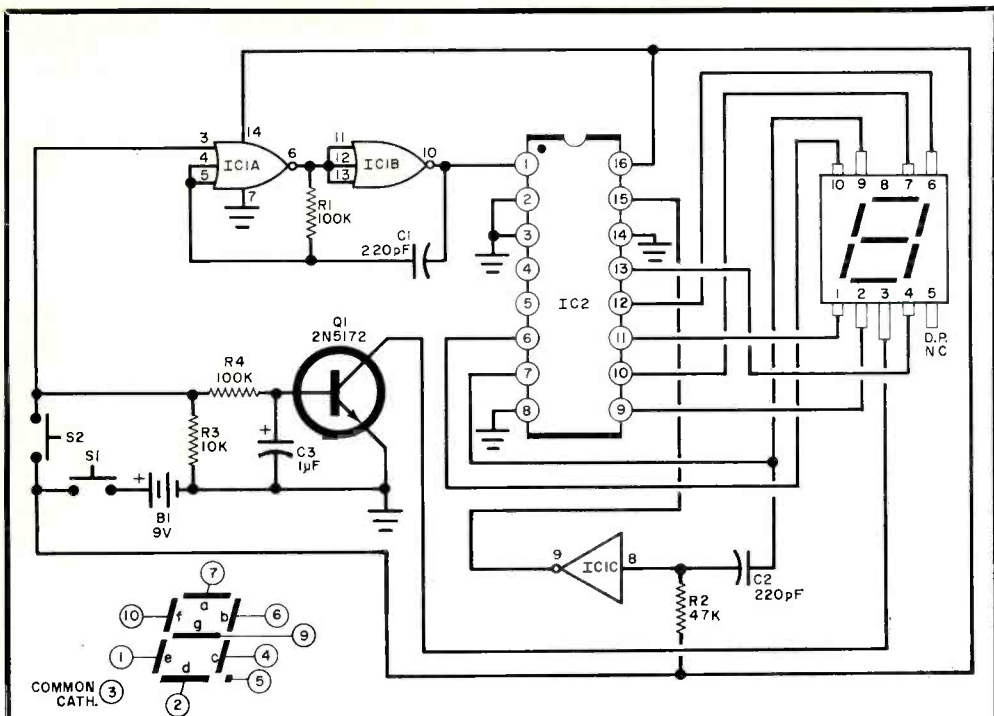

Fig. 2. Actual circuit for a single die. Two gates of IC1 form the 15-kHz oscillator. Its inverter provides a reset signal. IC2 drives the LED readout, turned on by Q1 biasing.

PARTS LIST

B1—9- or 12-volt transistor battery
 C1, C2—220-pF disc ceramic capacitor
 C3—1- μ F, 10-volt miniature electrolytic capacitor
 IC1—COSMOS dual 3-input NOR gate plus inverter (RCA CD4000AE)
 IC2—COSMOS decade counter/decoder (RCA CD4033AE)
 LED1—Seven-segment miniature LED read-

out (Monsanto MAN-3M)
 Q1—2N5172 transistor
 R1, R4—100,000-ohm, $\frac{1}{4}$ -watt resistor
 R2—47,000-ohm, $\frac{1}{4}$ -watt resistor
 R3—10,000-ohm, $\frac{1}{4}$ -watt resistor
 S1, S2—Single-pole, normally open pushbutton switch
 Misc.—Case, battery connectors, battery holder, wire, hardware, etc.

ated to reset the counter to zero. This reset, plus the blanking circuit forces the counter decoder to limit the display to the digits 1 through 6.

The actual circuit is shown in Fig. 2. IC1A and IC1B, in conjunction with R1 and C1, form the 15-kHz oscillator. Inverter IC1C provides the reset. When the center bar of the LED display (segment g) goes off as the display attempts to go from 6 to 7, the voltage present at segment g suddenly drops to zero. This pulse is differentiated by C2 and R2 and causes the inverter to reset the counter (via pin 15). IC2 is a COSMOS decade counter that takes pulses

at its pin 1 input and converts them to the correct signals to drive the 7-segment readout.

The common-cathode terminal of the LED readout (pin 3) is connected to transistor switch Q1. When normally open push-button switch S1 is closed, power is applied to the oscillator and IC2 causing the counter to cycle through its 1-to-6 sequence. When S2 is closed, the 15-kHz oscillator is stopped so the counter-driver holds whatever digit it has reached. Simultaneously, S2 biases Q1 on completing the LED circuit. This causes the LED to glow to indicate the random digit.

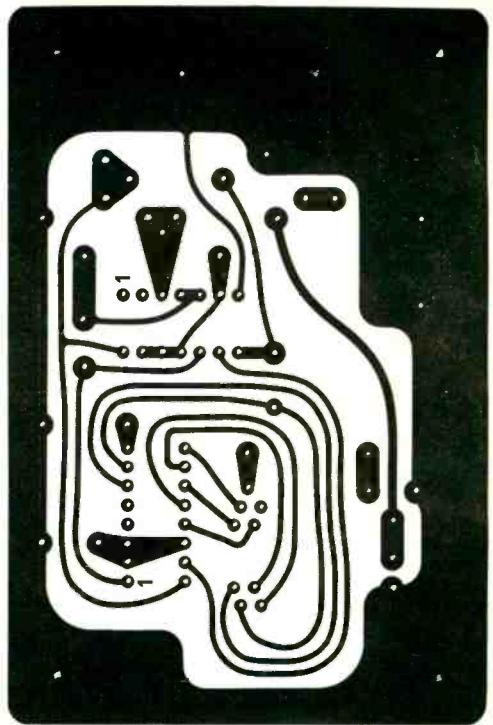
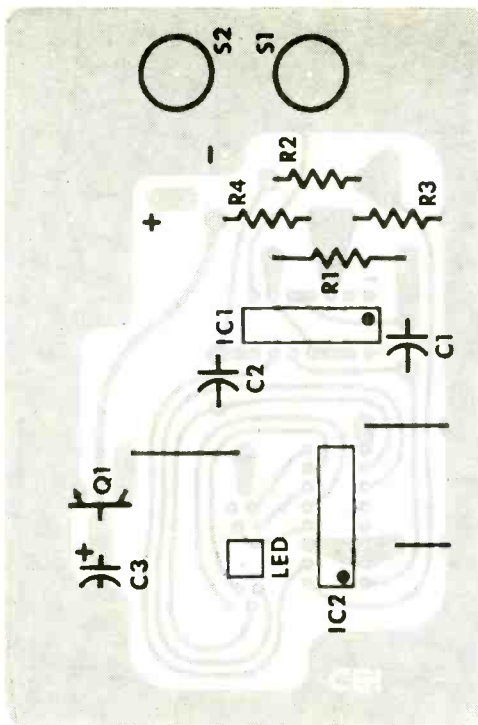

Fig. 3. Actual size foil pattern for a single die and the component installation. Take care in handling COSMOS IC's. They can be damaged by static electricity.

Construction. The components for a single die can be mounted on a PC board such as that shown in Fig. 3. Sockets may be used for the IC's, and Molex pins for the LED, though they can be soldered in place. Care should be used when handling the IC's. Although they have built-in diode protection, the oxide gate-insulating layer can be destroyed by static electricity. Contact with the foam plastic conventionally used to

package transistors should be avoided. The black foam used to pack MOS devices is conductive and will not cause any harm. It is suggested that the soldering iron used have a three-wire line cord and a grounded tip. The plastic housing the LED readout has a low melting temperature, so take care if soldering this component in place.

The completed board, or pair of boards if you want a set of two dice, can be mounted in any suitable chassis, with only the LED readout exposed through a cut-out and the pushbutton switches mounted on the front panel. If you are making a pair of dice, a single switch can be used for *S1*. Any 9-to-12-volt battery may be used as the power source.

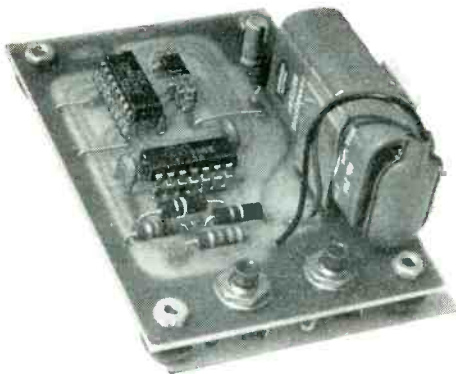

Photo shows how components, including battery and switches, mount on board.

Operation. Depressing *S1* starts the oscillator and counter and should be kept depressed during the entire operation. When *S2* is depressed, the oscillator stops and the LED will indicate the random digit. Due to the reset system used, on occasion the LED will not display a digit. This is a "no dice" condition and if it occurs, *S2* should be released, left open for as long as desired, and then depressed again. ♦

Single-Filament Tail Light Converter

BY MARVIN BEIER

MUST YOU RESTRICT your trailer hauling to daylight hours because you don't have the safety lights required by law for night hauling? If so, a simple converter circuit, installed in your trailer lamp circuit, can allow any single-filament trailer light to operate as tail and brake lights, four-way safety flashers, and individual turn signal indicators.

The converter circuit, shown in the schematic diagram, consists of two 10-watt resistors and two 25-volt, 5-ampere silicon diodes. These few components can be housed in a 4" x 2" x 2" metal utility box, which can then be bolted in any convenient location near the trailer lights. Connections to and from the converter circuit should be through a screwtype barrier block.

The cables from your car brake and tail

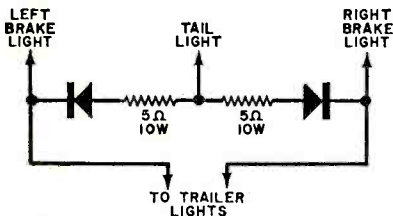

Only "hot" lead hookups are shown: circuit must be completed by connecting a cable between the trailer and car chassis.

lights and to the trailer lights should be #16 or heavier wire. Use spade lugs on the ends of the wires that connect to the barrier block.

Once installed between the car and trailer lights, the converter operates as follows: with the car lights turned on, current flows through the tail light lead and both pairs of resistors and diodes to the trailer lights. The brilliance of the trailer lights is somewhat subdued as a result of the voltage drops across the resistors.

Now, when the car brake is operated, current flow bypasses the resistors and diodes, going directly to the trailer lights via the left and right brake-light leads. Here, full current is delivered, and the trailer lights operate at full brilliance. The diodes are in reverse bias, preventing current from circulating through the diode/resistor circuit.

When the directional signal or four-way safety lights are operated, the trailer lights again glow at full brilliance. Each lamp can operate singly since the diodes again restrict the current flow in one direction.

You will notice from the schematic diagram that only one connection is shown to each of the trailer lights from the car. The diagram assumes that the trailer and car grounds are coupled together to complete the circuit. ♦

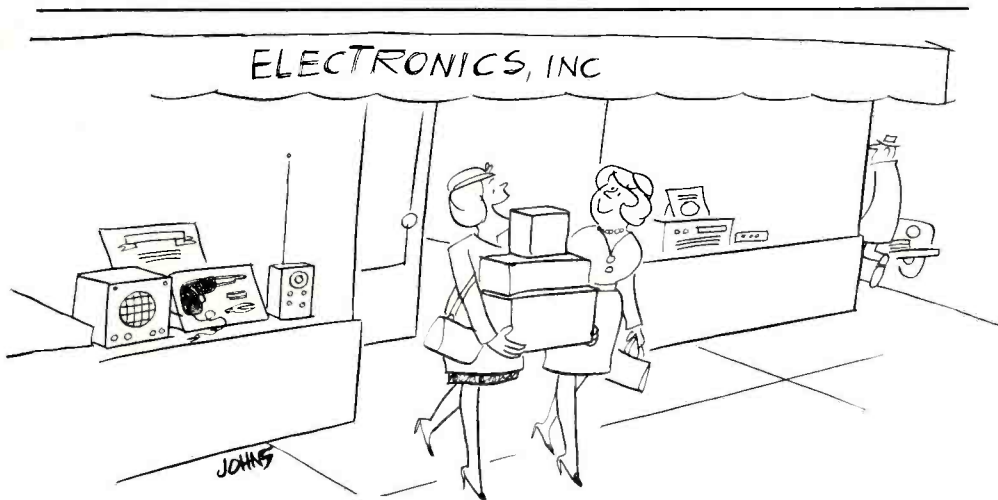

"I'll say one thing for Charles—He's no problem on birthdays and Christmas."

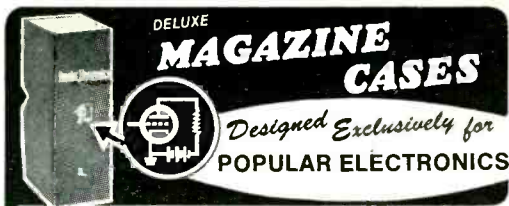

● The ideal way to save your valuable copies, keep them well protected and make it easy for you to refer to any issue at any time. Both decorative and attractive enough to enhance the decor of any room, each case holds a full year's copies. Constructed of reinforced fiberboard, these durable cases are covered in a rich-textured leatherette. The gold embossed back adds to its elegance and makes each case a welcome addition to your bookshelf or cabinet.

Magazine cases are available for any of your favorite magazines. They're only \$4.50 each, 3 for \$12.50, in any combination of titles ordered. Add 50c per case for postage and handling. Outside U.S.A. add \$1.00 per case ordered.

**CHARGE YOUR AMERICAN EXPRESS
OR BANKAMERICARD ACCOUNT**

Ziff-Davis Pub. Co., Dept. 23, 1 Park Avenue, New York 10016

My remittance in the amount of \$ _____ is enclosed. Please send magazine cases for the titles indicated below.

CHARGE: American Express BankAmericard

Account # _____

Signature _____

TITLE **EEHW-75** QUANTITY

Check One: All Black Maroon Back, Black Sides

Print Name _____

Address _____

City _____ State _____ Zip _____

PAYMENT MUST ACCOMPANY ORDER

ELECTRONIC EXPERIMENTERS HANDBOOK WINTER 1975 ADVERTISERS INDEX

READER SERVICE NO.	ADVERTISER	PAGE NO.
3	Cleveland Institute of Electronics	151, 152, THIRD COVER
1	Continental Specialties Corp	SECOND COVER
2	Datak Corporation, The	60
4	Delta Electronics Co.	24
6	EICO	24
7	Edsyn	60
5	Heath Company	67, 68, 69
8	James Electronics	6
9	Lafayette Radio Electronics	FOURTH COVER
10	Meshna, John Jr.	27
	NRI Schools	1, 2, 3
11	Schober Organ Corp., The	27
12	Unique Ideas, Inc.	8

TEST YOUR KNOWLEDGE OF SEMICONDUCTORS

BY WILLIAM R. SHIPPEE

- Transistor H_{FE} remains steady regardless of temperature.
(a) True (b) False
- Which of these elements used to dope semiconductor materials is an acceptor or p type?
(a) Phosphorous (b) Arsenic
(c) Antimony (d) Indium
- In a class A output stage, dissipation is always highest when there is no ac power output.
(a) True (b) False
- Mesa and planar epitaxial transistors give high-speed switching and good saturation characteristics at relatively high voltage ratings.
(a) True (b) False
- The configuration used most often for a transistor switching circuit is:
(a) Common collector (b) Common base
(c) Common emitter
- Many mesa and planar transistors exhibit negative resistance after breakdown voltage is reached.
(a) True (b) False
- Voltage feedback from the collector of a transistor stage tends to increase the output impedance of that stage.
(a) True (b) False
- Below (top) is schematic symbol for:
(a) Unijunction (b) SCR
(c) Tetrode (d) Npn transistor
- Below (left) is schematic symbol for:
(a) FET (b) SCR
(c) SCS (d) Npn transistor
- Below (right) is schematic symbol for:
(a) Symmetrical zener (b) SCS
(c) Npn transistor (d) SCR

(Answers below)

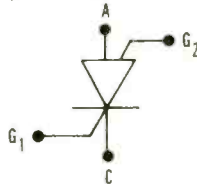
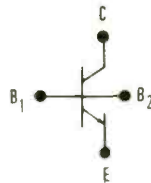

1 9 2 4 3 A 4 A 5 C 6 A 7 B 8 C 9 A 10 B

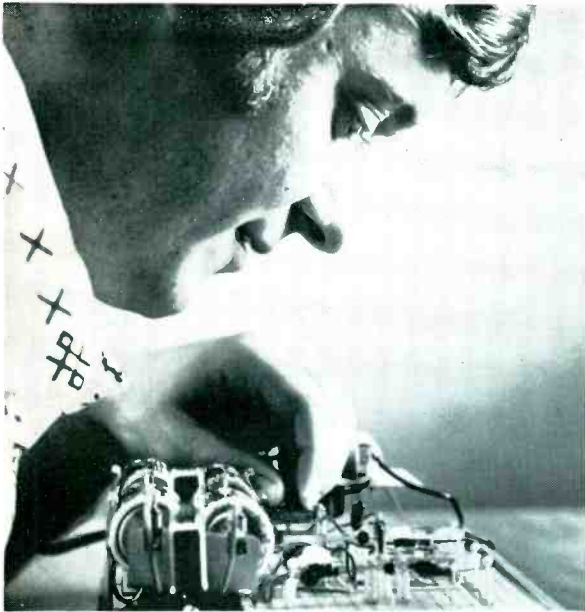

You Learn to Make Money ...with CIE's Electronics Laboratory!

Now you can learn Electronics by performing more than 200 practical, skill-producing experiments...with authentic industrial components...at home...in your spare time.

You learn by doing! This 161-piece Laboratory includes the up-to-date equipment you'll need — such things as an IC (integrated circuit), printed circuit board, FET (field effect transistor), photovoltaic cell, DC motor, microphone, multimeter, soldering iron and power supply.

You put theory into *practice* right in your own *home*... in your spare time...while you go right on pulling down your present pay. It's CIE's exciting space-age "Electronics Technology with Laboratory" program... a unique combination of CIE's special AUTO-PROGRAMMED® Lessons and laboratory equipment. It is the *practical* way to learn Electronics!

Prepare for a High-paying Career

You see, when you "learn by doing," you're *ready to do*...you're *armed* with the know-how to meet the challenges of a high-paying career in Electronics... prepared to go after an exciting, relevant job in a growing field such as medical technology, pollution control, radio and TV broadcasting, computers...just to name a few. Once you have some experience, you can make \$12,000 a year or more.

But that's not all! When you successfully complete your Electronics Laboratory course, you'll get a CIE Diploma. And, you'll be able to pass the Government FCC examination or be *entitled to a full refund of all tuition paid!* CIE's Money-Back Warranty is valid during the completion time allowed for your course.

Send today for CIE's 2 FREE BOOKS about opportunities in Electronics. For your convenience, we will try to have a representative call. Mail reply card or coupon to CIE...or write: Cleveland Institute of Electronics, Inc., 1776 E. 17th St., Cleveland, Ohio 44114.

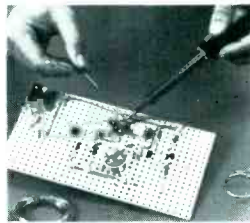

You learn how to construct circuits and connect them with a soldering iron, which is part of your CIE laboratory equipment. This "hands on" experience is extremely valuable.

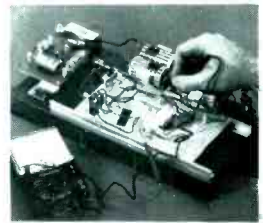

Testing and troubleshooting are an important part of your learning experience. Your laboratory has a precision multimeter to diagnose electronic troubles quickly and accurately.

APPROVED UNDER G.I. BILL

All CIE career courses are approved for educational benefits under the G.I. Bill. If you are a Veteran or in service now, check box for G.I. Bill information.

CIE Cleveland Institute of Electronics, Inc.

1776 East 17th Street, Cleveland, Ohio 44114
Accredited Member National Home Study Council

Please send me your 2 FREE BOOKS — The CIE school catalog, "Succeed in Electronics" and "How To Get a Commercial FCC License."



Name _____
(Please Print)
Address _____
City _____
State _____ Zip _____ Age _____

Veterans and Servicemen:
 Check here for G.I. Bill information.

EH-16

free

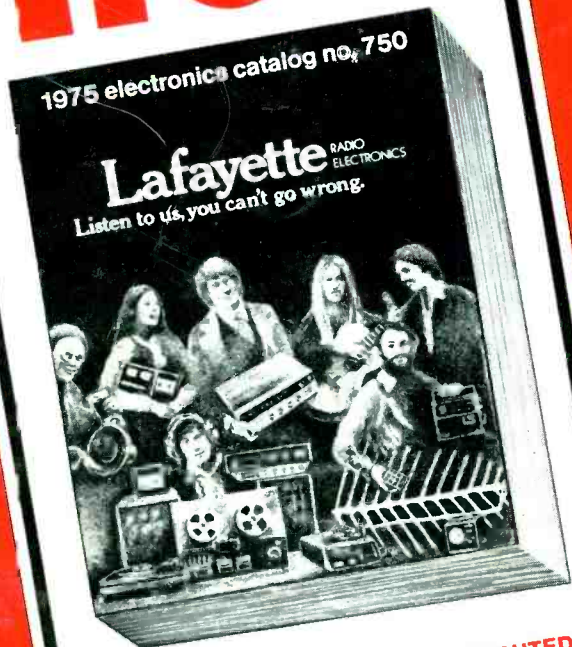

**IT'S THE ONLY NATIONALLY DISTRIBUTED
FULL-LINE CATALOG WITH A MAJOR
SHOWING OF THE NEWEST NAME-BRAND
ELECTRONICS PRODUCTS
FOR 1975!**

**SEND FOR IT
TODAY!**

The "NEW LOOK"

1975 LAFAYETTE RADIO ELECTRONICS CATALOG

If you're interested in electronics you NEED this catalog! Completely re-designed for easier-than-ever ordering, with the newest and best Lafayette and national-brand products for '75. And you get the same quality and service that has made Lafayette a leader for 55 years. Iron-clad guarantees! Lowest Prices! Professional Service! State-of-the-art Equipment! Pick and choose from over 18,000 quality electronics products! Now, more than ever, we're your "Single-trip" shopping center for everything in electronics.

SAVE ON EXCLUSIVE LAFAYETTE PRODUCTS PLUS THE BEST MAJOR BRAND NAMES

- Stereo and 4-Channel Music Systems
- Tape Recording Equipment • Car Stereo and Accessories • CB and Ham Gear • Police/Public Service Receivers • Car Stereo and Accessories • Antennas • Cameras • TV • PA and Test Equipment • Music Instruments and Amplifiers • Books • Electronic Calculators • Security Systems • PLUS PARTS, TUBES, BATTERIES, HARDWARE — ALL YOU NEED FOR QUALITY LIVING THROUGH ELECTRONICS

Lafayette

Listen to us, you can't go wrong.

STORES COAST TO COAST Check Your Yellow Pages or Shop by Mail

NEW! Bigger Pages
NEW! More Full Color
NEW! Easier-to-Read Type

free
MAIL TODAY!

Lafayette Radio Electronics
111 Jericho Tpke., Syosset, L.I., N.Y. 11791

09094

Send me your FREE 1975 Catalog.

Send a 1975 Electronics Catalog to my friend.

Name _____ Apt. _____

Name _____ Apt. _____

Street _____

Street _____

City _____

City _____

State _____ Zip _____

State _____ Zip _____

CIRCLE NO. 9 ON READER SERVICE CARD