

POPULAR ELECTRONICS

# 1978 ELECTRONIC EXPERIMENTER'S

# HANDBOOK<sup>®</sup> \$1.95

INCLUDING HOBBYIST MICROCOMPUTER SECTION

## FULL CONSTRUCTION PLANS FOR:

- A Digital Logic Probe...
- Auto Ignition Timing
- Light ... Photo Enlarger
- Controller ... Single-IC
- Weather Receiver...
- Minivolts Meter
- ... Night Cycling
- Safety Lights...
- HO Train Speed
- Control ... Low-Cost
- Metal Detector...
- Solid-State TV
- Camera ... Audio
- Companer ... AND MORE!

**PLUS:** Complete Home Computer Buying Directory

**BUILD A HOME ELECTRONIC BASEBALL GAME**  
 FEATURES CURVES, FASTBALLS, AND CHANGEUPS TO CHALLENGE THE "BATTER."

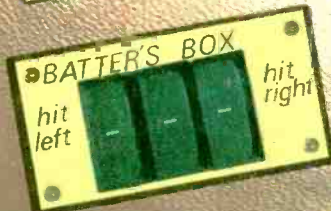
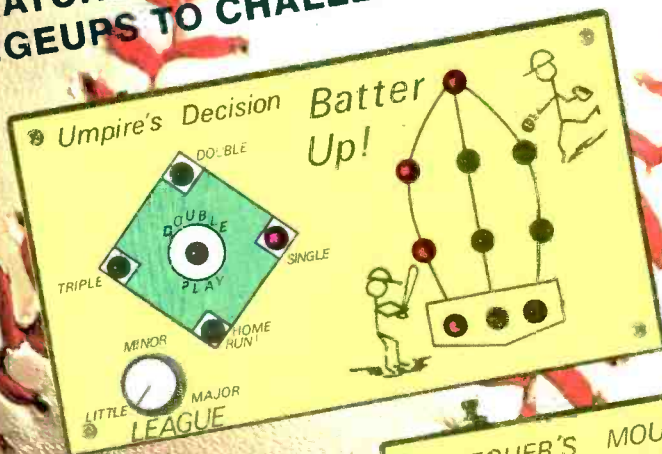

**A PERSONAL MICROCOMPUTER FOR \$100!** Includes video graphics chip.

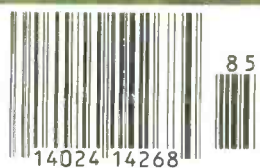

Electronics Exp. Hdbk

# SWTPC announces first dual minifloppy kit under \$1,000



Now SWTPC offers complete best-buy computer system with \$995 dual minifloppy, \$500 video terminal/monitor, \$395 4K computer.



### \$995 MF-68 Dual Minifloppy

You need dual drives to get full benefits from a minifloppy. So we waited to offer a floppy until we could give you a dependable dual system at the right price.

The MF-68 is a complete top-quality minifloppy for your SWTPC Computer. The kit has controller, chassis cover, power supply, cables, assembly instructions, two highly reliable Shugart drives, and a diskette with the Floppy Disk Operating System (FDOS) and disk BASIC (A floppy is no better than its operating system, and the MF-68 has one of the best available.) An optional \$850 MF-6X kit expands the system to four drives.



### \$500 Terminal/Monitor

The CT-64 terminal kit offers the premium features: 64-character lines, upper/lower case letters, switchable control character printing, word highlighting, full cursor control, 110-1200 Baud serial interface, and many others. Separately the CT-64 is \$325, the 12 Mhz CT-VM monitor \$175.



### \$395 4K 6800 Computer

The SWTPC 6800 comes complete with 4K memory, serial interface, power supply, chassis, famous Motorola MIKBUG® mini-operating system in read-only memory (ROM), and the most complete documentation with any computer kit. Our growing software library includes 4K and 8K BASIC (cassettes \$4.95 and \$9.95; paper tape \$10.00 and \$20.00). Extra memory, \$100/4K or \$250/8K.

**Other SWTPC peripherals** include \$250 PR-40 Alphameric Line Printer (40 characters/line, 5 x 7 dot matrix, 75 line/minute speed, compatible with our 6800 computer and MITS/IMSAI); \$79.50 AC-30 Cassette Interface System (writes/reads Kansas City standard tapes, controls two recorders, usable with other computers); and other peripherals now and to come.

#### Enclosed is:

- \_\_\_\_\_ \$1,990 for the full system shown above (MF-68 Minifloppy, CT-64 Terminal with CT-VM Monitor).
- \_\_\_\_\_ \$995 for the Dual Minifloppy
- \_\_\_\_\_ \$325 for the CT-64 Terminal
- \_\_\_\_\_ \$175 for the CT-VM Monitor
- \_\_\_\_\_ \$395 for the 4K 6800 Computer

\_\_\_\_\_ \$250 for the PF-40 Line Printer  
 \_\_\_\_\_ \$79.50 for AC-30 Cassette Interface  
 \_\_\_\_\_ Additional 4K memory boards at \$100  
 \_\_\_\_\_ Additional 8K memory boards at \$250  
 \_\_\_\_\_ Or EAC # \_\_\_\_\_ Exp. Date \_\_\_\_\_  
 \_\_\_\_\_ Or MC # \_\_\_\_\_ Exp. Date \_\_\_\_\_  
 Name \_\_\_\_\_ Address \_\_\_\_\_  
 City \_\_\_\_\_ State \_\_\_\_\_ Zip \_\_\_\_\_



Southwest Technical Products Corp.

219 W. Rhapsody, San Antonio, Texas 78216  
**London:** Southwest Technical Products Co., Ltd.  
**Tokyo:** Southwest Technical Products Corp./Japan

# Chances are, someone you know just bought a professional 3½ digit DMM kit for less than \$70.



Thousands of people have already bought the Sabtronics Model 2000 . . . for two main reasons. First, its incredible accuracy, range and professional features. And second, the incredibly low price of \$69.95.

People everywhere appreciate this bench/portable multi-meter. They depend on its basic DCV accuracy of 0.1% ±1 digit, its readings to ±1999 and its five functions giving 28 ranges, overload protection and 100% overrange.

The 2000 is automatically appealing to hobbyist and professional alike. With automatic overrange indication, automatic polarity, even automatic zeroing.

Best of all, it's easy to assemble. All the parts you'll need, including the high-impact case, come right along with the clear, step-by-step instructions.

The result is a professional quality 3½ digit DMM that you could have paid a lot more than \$69.95 for . . . possibly receiving a lot less. But this one's from Sabtronics, specialists in digital technology.

Maybe you should order yours before you turn the page.



Made in U.S.A.

**sabtronics**   
INTERNATIONAL INC.

P.O. Box 64683 Dallas, Texas 75206 (214) 369-7310

## GUARANTEE:

Our guarantee to you; examine the 2000 DMM kit for 10 days. If you're not satisfied, return it unassembled for a full refund of purchase price.

## SPECIFICATIONS:

DC volts in 5 ranges: 100µV to 1000V  
AC volts in 5 ranges: 100µV to 1000V  
DC current in 6 ranges: 100nA to 2A  
AC current in 6 ranges: 100nA to 2A  
Resistance: 0.1Ω to 20MΩ in 6 ranges  
AC frequency response: 40Hz to 50KHz  
9mm (.36") LED display  
Input impedance: 10MΩ  
Size: 8"W x 6.5"D x 3"H  
(203W x 165D x 76H mm)

Power requirements: 4 "C" cells (not included)

To: Sabtronics International, Inc. EH78  
P.O. Box 64683, Dallas, TX 75206

Please send me \_\_\_\_\_ Sabtronics Model 2000 DMM kit(s) at \$69.95 each. \_\_\_\_\_ subtotal

Shipping and handling, \$5.00 per unit\* \_\_\_\_\_ subtotal

Texas Residents Add Sales Tax \_\_\_\_\_

TOTAL enclosed \_\_\_\_\_

Name \_\_\_\_\_

Street Address \_\_\_\_\_

City \_\_\_\_\_

State \_\_\_\_\_ Zip \_\_\_\_\_

\*USA only Canada \$6 50. All other countries, \$10 00 (surface mail)



POPULAR ELECTRONICS

# 1978 ELECTRONIC EXPERIMENTER'S HANDBOOK

SOLID STATE COMPONENTS CHART .....	5
BATTER-UP! .....	7
<i>A home electronic baseball game of skill and quick reactions.</i>	
THREE-WAY POWER SUPPLY .....	14
HOW TO PROGRAM READ-ONLY MEMORIES .....	20
<i>Experimenter's guide to programmable ROM's.</i>	
LOW-COST COMPANDER .....	24
BUILD A MUSCLE FEEDBACK MONITOR .....	28
<i>New biofeedback technique helps to reduce tensions.</i>	
IC DIGITAL LOGIC MEMORY PROBE .....	32
TWO PROJECTS ADD SAFETY TO NIGHT BIKING	
ALTERNATELY FLASHING TAILLIGHTS .....	38
"ALWAYS-ON" BIKE LIGHTS .....	39
AUTOMATIC PHOTO ENLARGER CONTROLLER .....	40
<i>Selects proper exposure time and cuts down on photo paper waste.</i>	
LOW-COST METAL DETECTOR .....	43
BUILD THE MINIVOLTER .....	45
AN IGNITION TIMING LIGHT FOR IMPROVING GAS ECONOMY .....	47
HOW PHASE-LOCKED LOOPS WORK .....	50
<i>Theory and applications of a circuit revitalized by IC technology.</i>	
"TUG-OF-WAR" .....	56
<i>An electronic game project to challenge your reflexes.</i>	
TWO SINGLE-IC AM RECEIVER PROJECTS	
1 THE SIMPLEST AM/WWV RECEIVER .....	61
2 AN FAA WEATHER RECEIVER .....	63
LOW-COST REMOTE CONTROL OF APPLIANCES AND LIGHTS .....	65
BUILD A SINE-WAVE INVERTER .....	67
SIMPLE TESTERS FROM "JUNKBOX" PARTS .....	71
SOLID-STATE PHOTOCELLS FOR HOBBYISTS .....	73
<i>How light-sensitive semiconductors are used in practical circuits.</i>	
IC SPEED CONTROLLER FOR HO MODEL RAILROADS .....	75
BUILD THE TRANSISTOR IDENTOMETER .....	77
HOME FREEZER THAW ALARM .....	80
HOME COMPUTER BASICS .....	82
BUILD CYCLOPS .....	87
<i>First all solid-state TV camera for experimenters.</i>	
BUILD A PERSONAL MICROCOMPUTER FOR \$100 .....	92
<i>Elf II microcomputer trainer based on COSMAC 1802 microprocessor.</i>	
DIGITAL ELECTRONICS/MICROCOMPUTER PRODUCT DIRECTORY	
MICROCOMPUTERS .....	99
COMPUTER PERIPHERALS .....	108
COMPUTER MODULES .....	112
DIRECTORY OF MANUFACTURERS .....	119

COVER PHOTO: Conrad Studios

ELECTRONIC EXPERIMENTER'S HANDBOOK is published annually by Ziff-Davis Publishing Company at One Park Avenue, New York, New York 10016. Hersel B. Sarbin, President; John R. Emery, Senior Vice President-Finance and Treasurer; Charles B. Seton, Secretary.

COPYRIGHT © 1977 BY ZIFF-DAVIS PUBLISHING COMPANY. ALL RIGHTS RESERVED.

Material in this publication may not be reproduced in any form without permission. Requests for permission should be directed to Jerry Schneider, Rights & Permissions, Ziff-Davis Publishing Co., One Park Ave., New York, NY 10016

The Publisher has no knowledge of any proprietary rights which will be violated by the making or using of any items disclosed in this Handbook.

JOSEPH E. MESICS, *Publisher* • ARTHUR P. SALSBERG, *Editorial Director* • IVAN BERGER, *Senior Editor*  
EDWARD I. BUXBAUM, *Art Director* • PATRICIA GIRRIER-BROWN, *Production Editor* • GARY GARCIA, *Assistant Editor*  
ANDRE DUZANT, *Technical Illustrator* • JOSEPH E. HALLORAN, *Adv. Director* • JOHN J. CORTON, *Adv. Sales*  
LINDA BLUM, *Adv. Service Manager* • EDGAR W. HOPPER, *Publishing Director*

# Radio Hut

Money back guarantee. NO COD'S. Texas residents add 5% sales tax. Add 5% of order for postage and handling. Orders under \$15.00 add 75 cents. Foreign orders add 10% for postage.

For your convenience, call your BankAmericard or Master Charge orders in on our Toll Free Watts Line: 1-800-527-2304. Texas residents call collect: 1-214-271-8423.



P.O. Box 38323E  
Dallas, Texas 75238



## 60Hz CRYSTAL TIME BASE

This kit enables a MOS clock circuit to operate from a DC power source. Ideal for car, camper, van, boat, etc. 60Hz output with an accuracy of .005% (typ.). Low power consumption 2.5 mA (typ.). Small size will fit most any enclosure. Single MOS IC oscillator/divider chip 5-15 volts DC operation.

ONLY \$5.95 each

2 for \$10.00

### SOCKETS

14 pin low profile	.22
16 pin low profile	.25
18 pin low profile	.30
28 pin low profile	.69
40 pin low profile	.89

### LS

74LS00	.26	74LS145	1.00
74LS02	.26	74LS151	.70
74LS03	.26	74LS153	.70
74LS04	.30	74LS155	.69
74LS05	.32	74LS156	.76
74LS08	.26	74LS157	.95
74LS09	.26	74LS158	.85
74LS10	.26	74LS160	.85
74LS11	.35	74LS161	.85
74LS13	.58	74LS162	.85
74LS14	1.05	74LS163	.85
74LS15	.26	74LS168	.85
74LS20	.24	74LS169	.85
74LS21	.35	74LS170	2.00
74LS22	.35	74LS173	1.10
74LS26	.35	74LS174	1.00
74LS27	.35	74LS175	1.00
74LS30	.34	74LS190	.95
74LS32	.35	74LS191	.95
74LS37	.33	74LS192	.95
74LS38	.38	74LS193	.95
74LS40	.34	74LS194	.95
74LS42	.80	74LS195	.85
74LS43	.85	74LS196	.85
74LS44	.26	74LS197	.85
74LS45	.26	74LS251	.85
74LS47	.75	74LS253	.85
74LS74	.49	74LS257	.85
74LS76	.49	74LS258	.85
74LS96	.45	74LS260	.26
74LS90	.85	74LS266	.26
74LS92	1.00	74LS279	.55
74LS93	1.00	74LS290	.75
74LS109	.49	74LS293	.75
74LS112	.49	74LS295	.95
74LS113	.40	74LS298	.95
74LS114	.40	74LS365	.55
74LS125	.55	74LS366	.55
74LS126	.65	74LS367	.55
74LS132	.00	74LS368	.55
74LS133	.35	74LS390	1.75
74LS136	.39	74LS393	1.45
74LS138	.85	74LS670	3.25
74LS139	.85		

### RESISTORS OVER 50,000,000 IN STOCK

*330 ohm	22K ohm
470 ohm	27K ohm
1K ohm	33K ohm
1.2K ohm	39K ohm
2.2K ohm	43K ohm
3.3K ohm	47K ohm
4.7K ohm	82K ohm
6.8K ohm	100K ohm
10K ohm	150K ohm
20K ohm	220K ohm

All resistors are PC lead, but they are not pulloffs. The leads are about 1/4". 100 minimum order for each value.  
NO MIX 100/.99  
\*Value in 1/8W only. 1/4W unless otherwise specified. Most are 10% tolerance.

### CMOS

CD4000	.19	CD4040	1.00
CD4001	.19	CD4041	.69
CD4002	.19	CD4042	1.05
CD4006	1.20	CD4043	.60
CD4007	.19	CD4044	.60
CD4009	.47	CD4046	1.50
CD4010	.47	CD4047	1.89
CD4011	.19	CD4049	.49
CD4012	.19	CD4050	.49
CD4013	.32	CD4051	1.25
CD4014	.78	CD4053	1.25
CD4015	.78	CD4056	1.15
CD4016	.32	CD4066	.78
CD4017	.95	CD4071	.19
CD4018	.95	CD4081	.23
CD4019	.45	CD4507	1.00
CD4020	.97	CD4508	2.80
CD4021	.97	CD4510	1.10
CD4022	.97	CD4512	1.10
CD4023	.19	CD4516	1.10
CD4024	.75	CD4518	1.10
CD4025	.19	CD4520	1.10
CD4027	.45	CD4528	.87
CD4028	.89	74C02	.25
CD4029	.99	74C04	.32
CD4030	.35	74C107	.79
CD4035	.99		

ORDER BY PHONE. Charge your order to BankAmericard or Master Charge.

USE OUR TOLL FREE WATTS

# 1-800-527-2304

### RADIO HUT GUARANTEE

If you are not satisfied with any of our products NO MATTER WHAT THE REASON we offer you a full money back guarantee if the product or products are returned within 14 days after you receive them.

CIRCLE NO 20 ON FREE INFORMATION CARD

POPULAR ELECTRONICS

# 1978 ELECTRONIC EXPERIMENTER'S HANDBOOK®

## ZIFF-DAVIS PUBLISHING COMPANY

Hershel B. Sarbin  
President

Philip B. Korsant  
Executive Vice President

Furman Hebb  
Executive Vice President

John R. Emery  
Senior Vice President, Finance and Treasurer

Phillip T. Heffernan  
Senior Vice President

Edward D. Muhlfeld  
Senior Vice President, Sports Division

Philip Sine  
Senior Vice President

Frank Pomerantz  
Vice President, Creative Services

Arthur W. Butzow  
Vice President, Production

Lawrence Sporn  
Vice President, Circulation

George Morissey  
Vice President

Sydney H. Rogers  
Vice President

Sidney Holtz  
Vice President

Albert S. Traina  
Vice President

Paul H. Chook  
Vice President, Market Planning

Edgar W. Hopper  
Vice President

Robert N. Bavier, Jr.  
Vice President

Charles B. Seton  
Secretary

Jerry Schneider  
Vice President & Administrative Director, Annuals

William Ziff  
Chairman

W. Bradford Briggs  
Vice Chairman

Ziff-Davis Publishing Company  
Editorial and Executive Offices  
One Park Avenue, New York, New York 10016  
212-725-3500

Midwestern Office  
The Patis Group 4761 West Touhy Ave.  
Lincolnwood, Illinois 60646, 312-679-1100  
Gerald E. Wolf, Thomas Hockney  
Michael Neri

Western Office  
9025 Wilshire Boulevard, Beverly Hills, Cal. 90211  
213-273-8050, BRadshaw 2-1161  
Western Advertising Manager, Bud Dean

Japan  
James Yagi, Oji Palace Aoyama  
6 Chome, Minato-Ku, Tokyo 407-1930/6821  
582-2851



1978 ELECTRONIC EXPERIMENTER'S HANDBOOK is published annually by the Ziff Davis Publishing Company, One Park Avenue, New York, N.Y. 10016. Also publishers of Stereo Review, Popular Electronics, Citizens Band Handbook, Tape Recording and Buying Guide, Stereo Directory and Buying Guide, and Communications Handbook.

ELECTRONIC EXPERIMENTER'S HANDBOOK

DELUXE  
**MAGAZINE CASES**

*Designed Exclusively for*  
**YOUR FAVORITE ZIFF-DAVIS MAGAZINES**

The ideal way to save your valuable copies, keep them well protected and make it easy for you to refer to any issue at any time. Both decorative and attractive enough to enhance the decor of any room, each case holds a full year's copies. Constructed of reinforced fiberboard, these durable cases are covered in a rich-textured leatherette. The gold embossed back adds to its elegance and makes each case a welcome addition to your bookshelf or cabinet.

Cases are available for your favorite magazines

Only \$5.95 each, 3 for \$15.50 in any combination of titles, including all postage and handling charges. Outside U.S.A. add \$1 per case.

CHARGE YOUR ORDER TO YOUR AMERICAN EXPRESS, BANKAMERICARD, MASTER CHARGE OR DINERS CLUB ACCOUNT.



Ziff-Davis Serv. Div., Dept. JJ, 595 B'way, N.Y. 10012  
Please send the Magazine Cases indicated below:  
TITLE \_\_\_\_\_ QUANTITY \_\_\_\_\_

CHECK:  All Black  Maroon Back, Black Sides  
 ENCLOSED IS \$ \_\_\_\_\_ EEH-78

CHARGE:  BankAmericard  Master Charge  
 American Express  Diners Club

Account # \_\_\_\_\_ Exp. Date \_\_\_\_\_  
Master Charge Interbank # \_\_\_\_\_  
(4 numbers over your name)

Signature \_\_\_\_\_  
Print Name \_\_\_\_\_  
Address \_\_\_\_\_  
City \_\_\_\_\_ State \_\_\_\_\_ Zip \_\_\_\_\_  
Residents of Calif., Col., Fla., Ill., Mich., Mo., N.Y. State, D.C. and Tex. add applicable sales tax.

# SOLID STATE COMPONENTS CHART

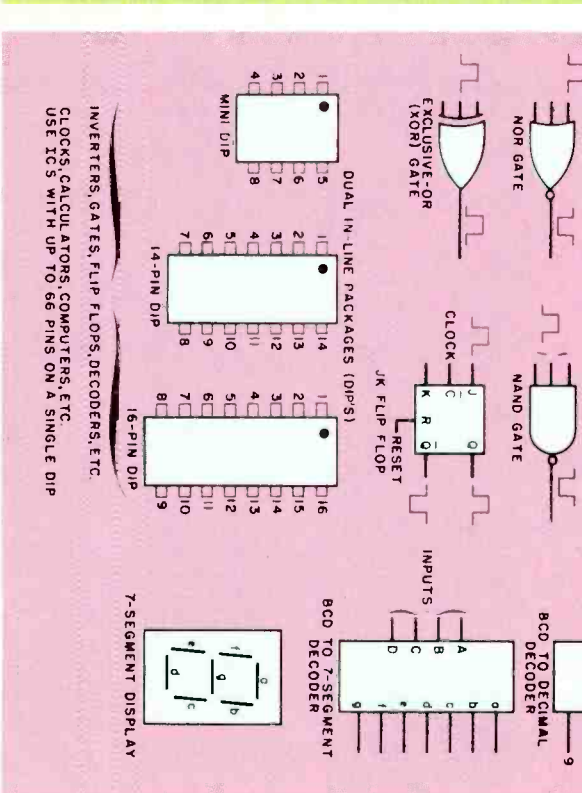
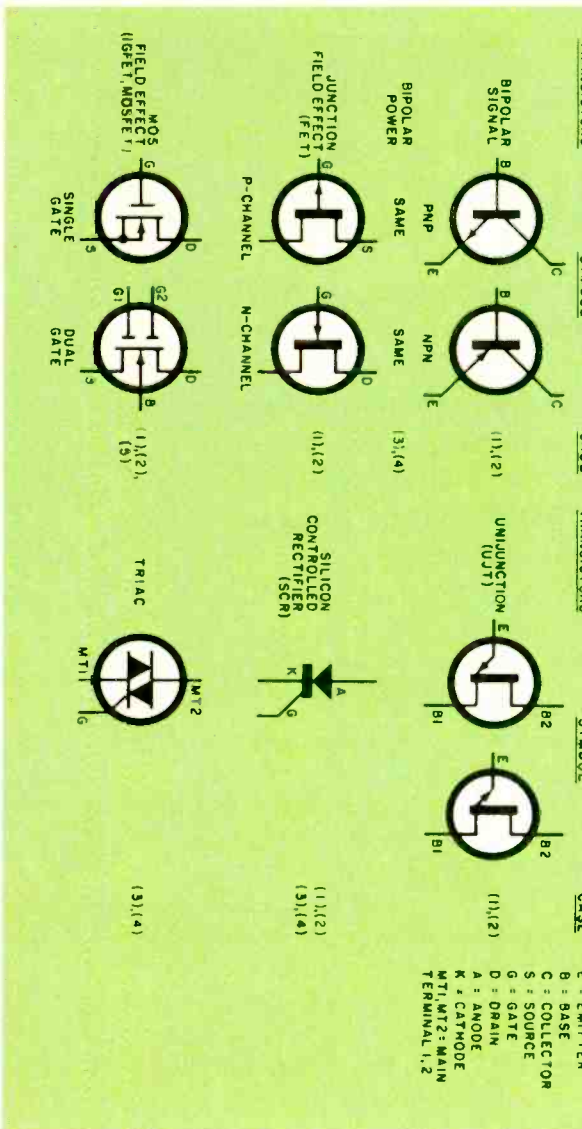
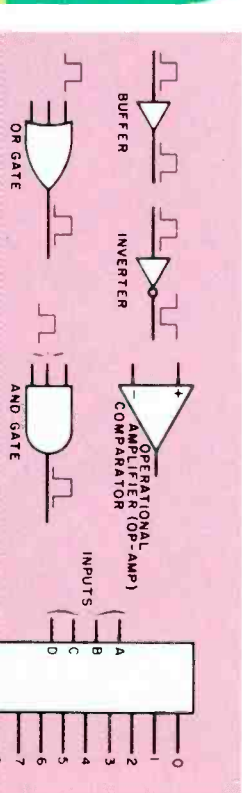
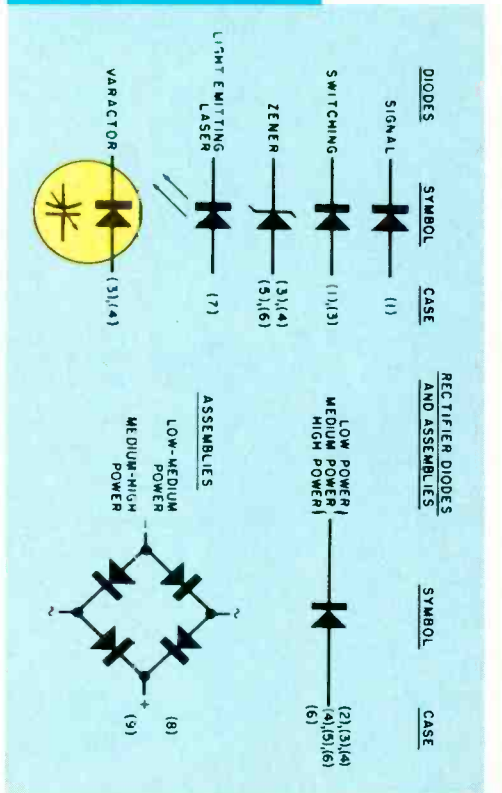
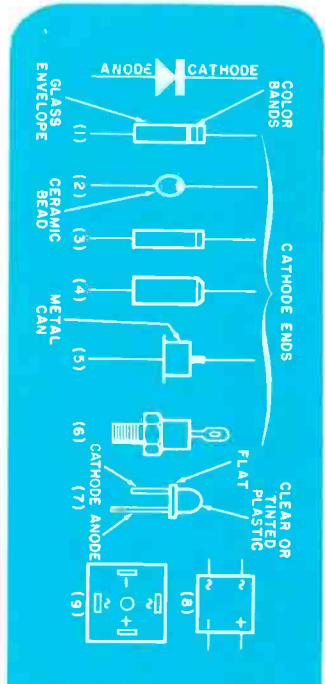

# BASIC in ROM Computers by Ohio Scientific

If you're just getting into personal computing and are buying your first machine, you're probably confused by the myriad of companies and products available.

However, there is one simple guideline you should follow when choosing your first computer. Be sure that it is capable of giving you full floating-point BASIC the instant you turn it on. Machines with full 8K BASIC in ROM cost as little as \$298.00. Why should you settle for anything less?

## Challenger IIP



The Challenger IIP from Ohio Scientific is the ideal personal computer complete with BASIC in ROM and plenty of RAM (4K) for programs in BASIC.

Complete with an audio cassette interface, the Challenger IIP uses a full computer keyboard, not a calculator keyboard.

In addition, the Challenger IIP comes complete with a full 64 character-wide video display, not a 40 character display. The user simply connects a video monitor or home TV set via an RF converter (not supplied) and optionally, a cassette recorder for program storage.

The Challenger IIP comes complete with a 4 slot backplane and case for only **\$598.00**. Fully Assembled.

## Model 500

The Model 500 is a fully populated 8 x 10 P.C. Board with 8K BASIC in ROM, 4K RAM, serial port and Ohio Scientific Bus compatibility for instant expansion. All you need is a small power supply (+5 at 2 amps and -9 at 500 MA) and an ASCII terminal to be up and running in BASIC. And all for only **\$298.00**.

## Super Kit

The Super Kit is a 3 board set with a 500 board (like the Model 500) without the serial interface.

The ROMs are configured for use with the included, fully assembled 440 video board to provide a full BASIC computer and terminal.

The Super Kit also includes a fully assembled 8 slot backplane board which gives you 6 open slots for expansion.

To be up and running in BASIC simply plug the boards together, supply power (+5 at 3 amps and -9 at 600 MA), add an ASCII parallel keyboard plus a video monitor or TV set via an RF converter (not supplied).

Total price for the "kit" **\$398.00**.

- Send me the Fall '77 Catalog. I enclose \$1.  
 I would like to order directly from this advertisement.  
 (Please allow up to 60 days for delivery)

NAME \_\_\_\_\_

ADDRESS \_\_\_\_\_

CITY \_\_\_\_\_ STATE \_\_\_\_\_ ZIP \_\_\_\_\_

**To order:** Payment by:

BAC (Visa) \_\_\_\_\_ MC \_\_\_\_\_ Money Order \_\_\_\_\_

Credit Card Account # \_\_\_\_\_

Interbank # (Master Charge) \_\_\_\_\_

Model 500 Boards @ **\$298.00** \_\_\_\_\_

Challenger IIP @ **\$598.00** \_\_\_\_\_

Super Kit @ **\$398.00** \_\_\_\_\_

Ohio Residents add 4% sales tax \_\_\_\_\_

TOTAL CHARGED OR ENCLOSED \_\_\_\_\_

Order directly from: Ohio Scientific, 11679 Hayden St.,  
 Hiram, Ohio 44234 or your local OSI dealer

All orders shipped insured UPS unless otherwise requested.

# OHIO SCIENTIFIC

11679 Hayden • Hiram, Ohio 44234

CIRCLE NO 19 ON FREE INFORMATION CARD



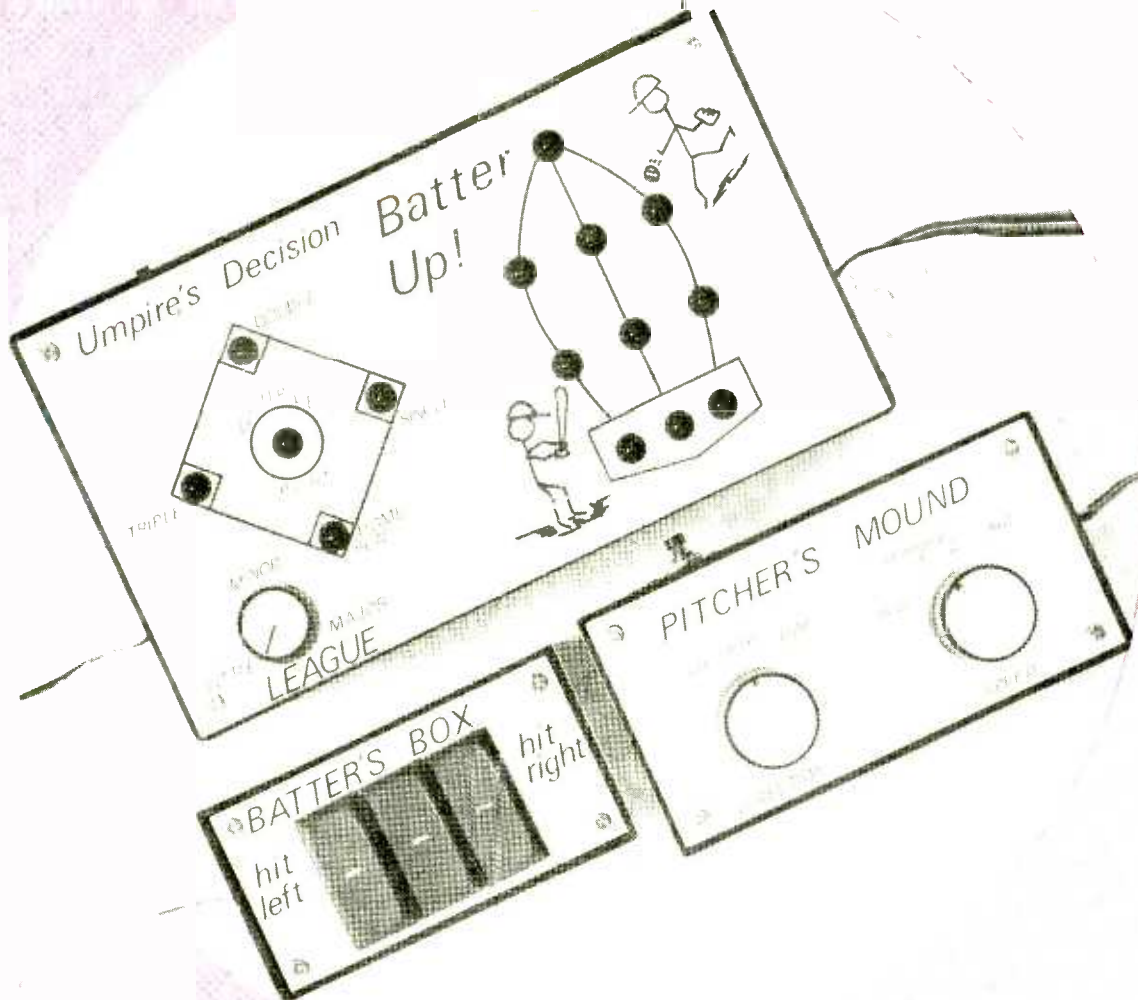

## Build

### *A game of skill and quick reactions*

BY JAMES J. BARBARELLO

**T**HE "Batter Up" electronic game described here simulates the game of baseball. It incorporates sufficient variations in "pitching" speed and changeups to play the game without outgrowing it. The strategy is to outfox your opponent by determining which pitch is his weakness.

The circuit makes use of the familiar 555 IC timer, which works properly with

a power supply of from 5 to 15 V d.c. Low current drain—due in part to LED blanking—allows standard-type batteries to provide many hours of play.

**Game Operation.** The game is played by two people who alternate as Pitcher and Batter. The pitcher's arsenal consists of a left curve, right curve, and straight balls. Each can be slow, fast, or one of two changeups (a total of 12 different pitches). The "ball" is thrown and travels its pitcher-determined route to end up over home plate. The batter must decide from which direction the ball is coming and "hit" it as it passes over home plate by depressing a switch cor-

responding to that direction (i.e., left, center, or right bat). If the batter "swings" too early or too late, it's a strike. If the batter hits the ball and keeps the bat depressed, a hit will be displayed. The type of hit (single, double, etc.) is chosen essentially at random, but the batter's chances for each type of hit are the same as an average .300 major-league hitter.

To make the game more realistic (and interesting), the batter can also hit into a double play (counts as one out if no men are on base). If the batter tries to cheat and depress more than one bat simultaneously, more than one home plate LED will light, indicating that a foul ball is to be counted. A control on the playing field allows the players to decide if they wish to play in the Little, Minor, or Major leagues. You can also add an option that provides an audible signal (a short beep) each time someone gets a hit.

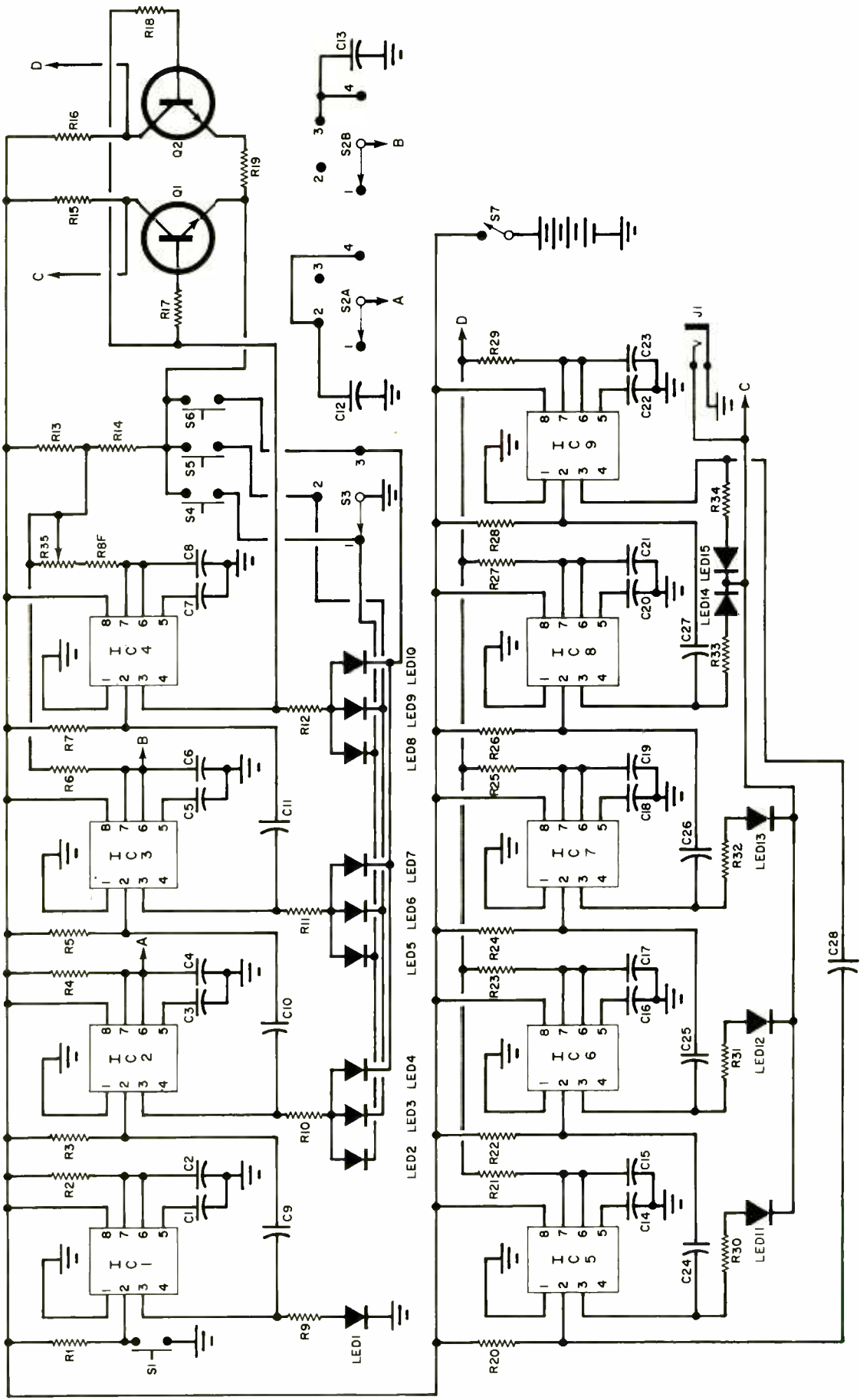

Fig. 1. Shown is complete schematic diagram for Batter Up.

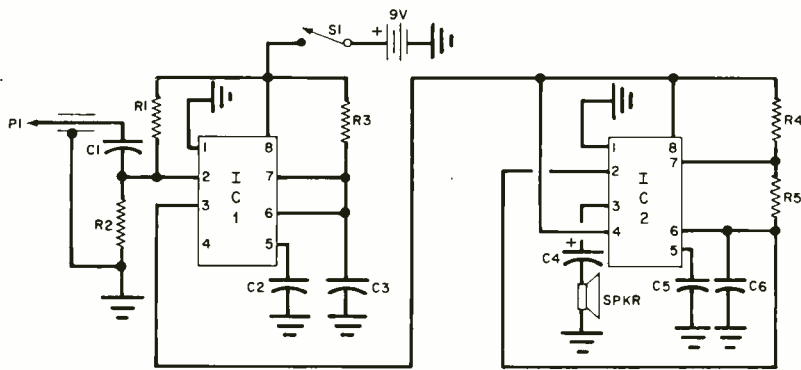

Fig. 2. Audible hit indicator option. When IC1 is on, the tone is heard from IC2 in the form of a ¼-sec. beep.

### PARTS LIST

- B1—9-V battery
  - C1, C2, C5, C6—0.01  $\mu$ F, 25-V disc ceramic capacitor
  - C3—0.1  $\mu$ F, 25-V disc capacitor
  - C4—2.2  $\mu$ F, 16-V electrolytic capacitor
  - IC1, IC2—NE555V IC timer (or equiv.)
- The following resistors are ¼-W, 10% tolerance.
- R1, R2—100,000 ohms
  - R3—2.2 megohms
  - R4—47,000 ohms
  - R5—4800 ohms
- S1—S.p.s.t. switch
  - Spkr.—2" dynamic speaker (Radio Shack 40-245 or equiv.)
  - P1—Miniature phone plug
  - Misc.: Suitable enclosure (Radio Shack 270-230 or equiv.); 9-V battery clip; tape or epoxy; printed circuit board; hook-up wire; solder, etc.

**About the Circuit.** The circuit is composed of a number of timers in the monostable (one shot) mode. Basically, a trigger input causes an output pulse whose width is determined by the value of a timing resistor and capacitor.

### PARTS LIST

- B1-B4—1½-volt "C" cells
  - C1-C14, C16-C22, C24-C28—0.1  $\mu$ F, 25 V disc capacitor
  - C15, C23—0.01  $\mu$ F, 25 V disc capacitor
  - IC1-IC9—NE555V IC timer (or equiv.)
  - LED1-LED15—TIL-32 LED (or equiv.)
  - Q1, Q2—2N5129 (or equiv.)
- The following resistors are ¼-W, 10% tolerance unless otherwise noted:
- R1, R3, R5, R7, R20, R22, R24, R26, R28—100,000 ohm
  - R2, R4, R6, R8—470,000 ohm
  - R9-R12, R30-R34—220 ohm
  - R13-R19—10,000 ohm
  - R21—86,000 ohm
  - R23, R25—390,000 ohm
  - R27—68,000 ohm
  - R29—220,000 ohm
  - R35—2 megohm, ½-W linear-taper pot
- S1—S.p.s.t. momentary pushbutton switch (normally open)
  - S2, S3—S.p., 3-section, 12-pos. rotary switch
  - S4, S5, S6—Momentary pushbutton switch, normally open (Poly Paks 92CU1749, specify "-")
  - S7—S.p.s.t. switch
  - J1—Miniature phone jack (if Sound Option is used)
- Misc.—4"  $\times$  2¼"  $\times$  2½" enclosure (Radio Shack 270-231 or equiv.); 7¾"  $\times$  4¾"  $\times$  2¾" enclosure (Radio Shack 270-232 or equiv.); 5 1/16"  $\times$  25%  $\times$  1¾" enclosure (Radio Shack 270-233 or equiv.); four "C" cell battery holder (Radio Shack 270-390 or equiv.); 12-conductor flat cable (3 feet); solder; printed circuit board; etc.
- Note—The following are available from J.A.L. Associates, P.O. Box 107, Eatontown, N.J. 07724: Etched and drilled main pc board (specify B-UP) \$8.95; etched and drilled set of three pc boards (main, Batter's Box, and Sound Option, specify B-PKG) \$10.60. Price includes shipping. Allow 3 to 6 weeks for delivery. N.J. residents add 5% sales tax.

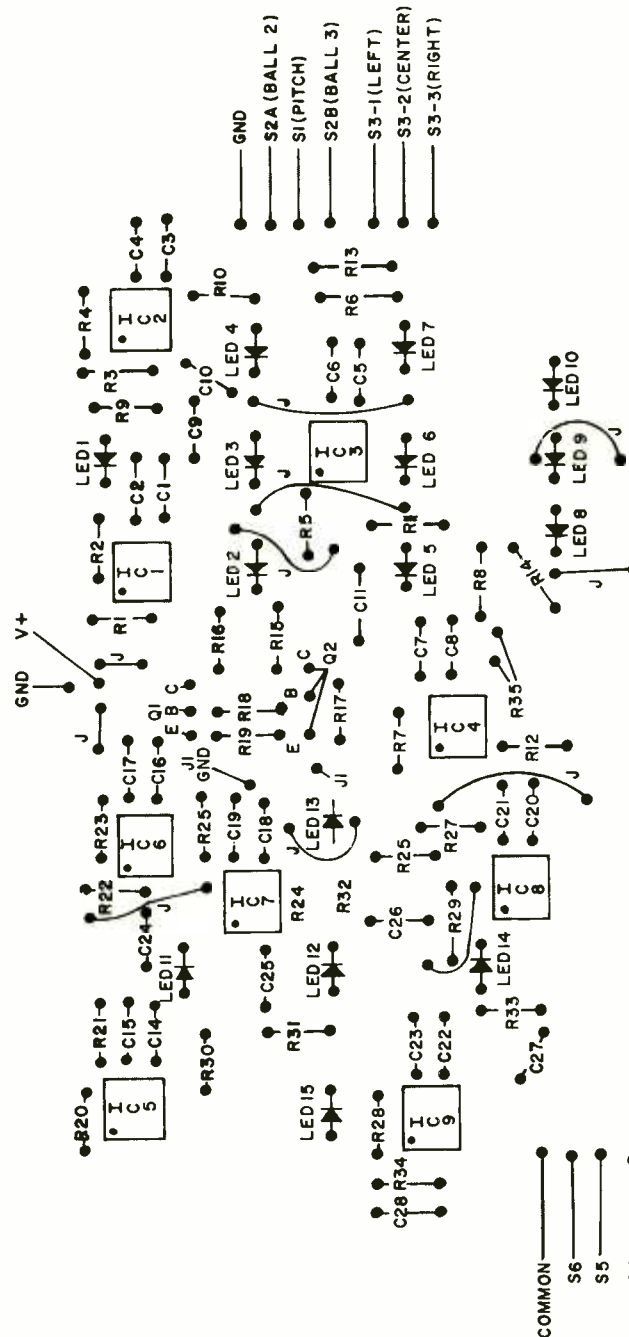
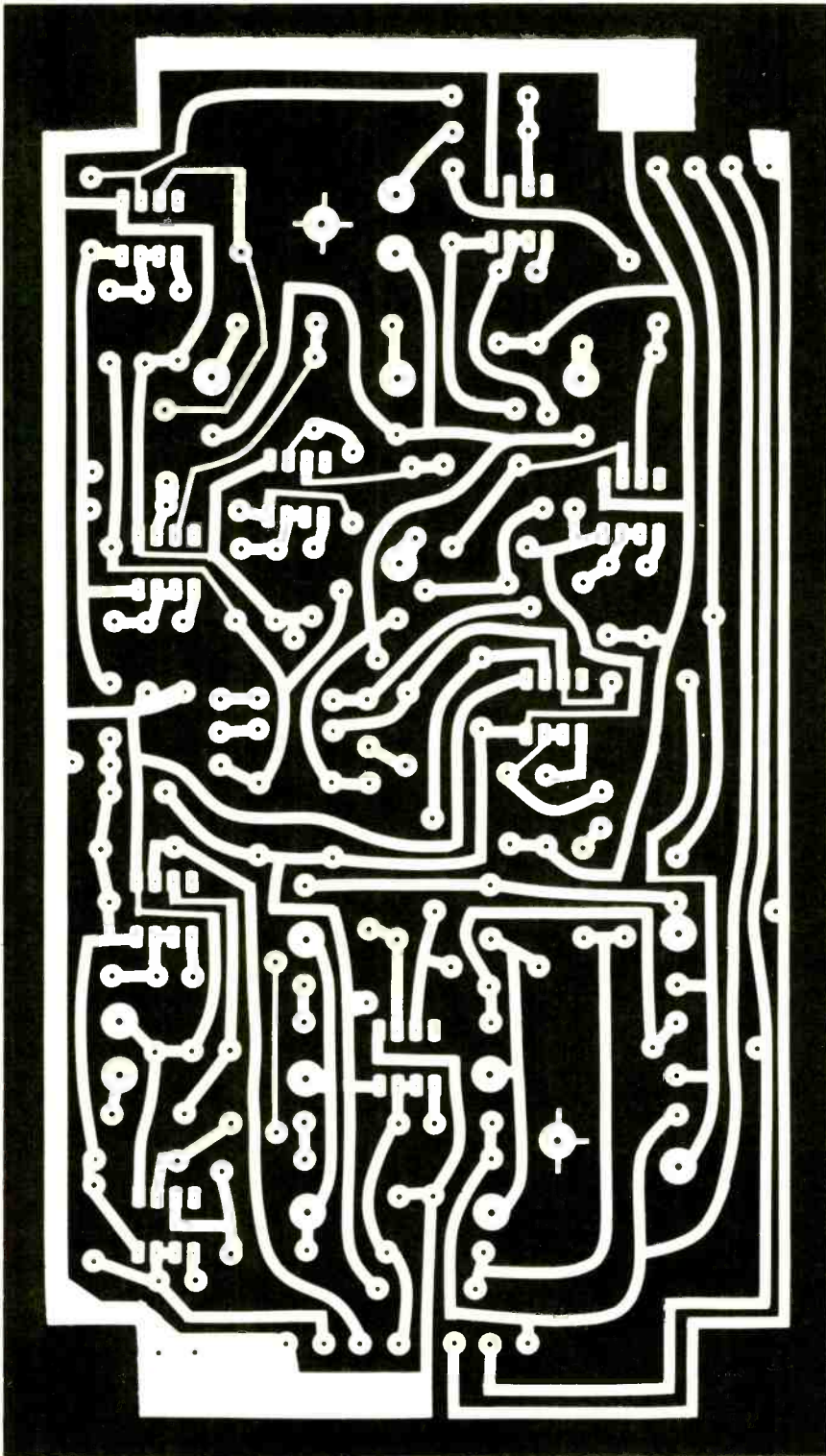

Fig. 3. Component placement guide for Batter Up. Etching and drilling guide is on page 10.



*Etching and drilling guide for main pc board of Batter Up.*

The schematic diagram for Batter Up is shown in Fig. 1. When *S1* is momentarily depressed, it triggers *IC1*, which produces a 0.05-second-wide pulse at pin 3. The pulse is capacitively coupled to pin 2 of *IC2*. The negative edge of the pulse triggers *IC2* and the process proceeds down the line. Switch *S3* grounds the cathodes of one of the three LED banks and one side of either *S4*, *S5* or *S6*. The grounded LED bank will light in sequence. The switch corresponding to the lighted LED bank must be depressed in order to ground voltage divider *R13-R14* and stop the sequence. As an example, assume *S3* is in position 1. When *S1* is momentarily depressed, *LED1*, *LED2*, *LED5*, and *LED8* will light in turn. If *S4* is depressed before *C6* charges up to two-thirds of the supply voltage, the sequence will stop at *LED5*, which will remain lighted as long as *S4* is closed. Depressing *S4* after *LED8* is extinguished has no effect. Depressing *S4* after *IC4* is triggered and before *C8* reaches two-thirds of the supply voltage (while *LED8* is on), *LED8* will stay on and the junction of *Q2* and *R19* will be grounded. Transistors *Q1* and *Q2* will now saturate, causing point *C* to go to ground and point *D* to go to half of the supply voltage. These two voltages are routed to the ring counter made up of *IC5* through *IC9*. The ring counter is initiated when power is applied, but since the LED cathodes are at *V+*, they do not light. When the voltages at points *C* and *D* are applied to the ring counter simultaneously, the voltage at point *D* halts the counting. Point *C* then grounds the cathodes of the LEDs, causing the LED corresponding to the one timer in the high state to light.

The time constants associated with the ring counter stages produce the following probabilities of occurrence (expressed as percentages): single—66.67%; double—13.34%; triple—3.34%; home run—10%; and double play—6.67%. The probabilities are independent of each other and of previous occurrences. The rate of counting makes the selection process sufficiently random.

The pitching adjustment for Little, Minor, or Major League is made with *R35*. The charging time for *IC4* is adjustable from 0.05 second (charging resistor = 470 k) to 0.275 second (charging resistor = 2.47 meg.). Thus, the time the home plate LED is lighted is 5½ times longer in the Little League than it is in the Majors. Potentiometer *R35* is continuously variable so that adjustment to times between the indicated positions is possible. This potentiometer only ad-

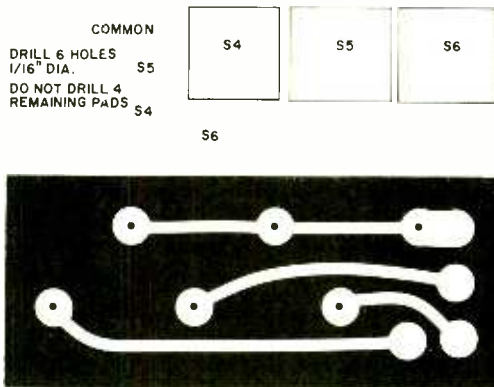

Fig. 4. Etching and drilling guide and parts placement for Batter's Box. Note that switches are mounted on pc board.

Inter-unit wiring is best done with a 3-foot length of flat cable (12-conductor is satisfactory). This cable is extremely flexible and will not interfere with play. A 7-conductor piece and a 4-conductor piece are also required (both can be obtained from the 12-conductor piece).

The Batter's Box includes switches S4, S5, and S6. Calculator switches have been chosen as they seem to be best for most people's reactions. A rectangular cutout  $\frac{1}{2} \times \frac{15}{16}$  ( $1.3 \times 2.4$  cm) is made in the top plate. The switches mount on the pc board, as shown in Fig. 4. This arrangement holds them in place. The cable enters the case through a hole drilled on one of the short sides and the four leads are soldered to the undrilled pads. Once wired, the pc board can be secured to the top plate with tape or a few dabs of epoxy. The case is  $4 \times 2\frac{1}{4} \times 2\frac{1}{4}$  ( $10.2 \times 5.7 \times 5.7$  cm). Lettering is the same as for the playing field.

The Pitcher's Mound uses a 12-position, 3-section, single-pole rotary switch and is wired as shown in Fig. 5. Again, the cable enters the  $5\text{-}1/16 \times 2\frac{5}{8} \times 1\frac{5}{8}$  ( $12.9 \times 6.7 \times 4.1$ -cm) case through a hole drilled in one of the short sides.

**Sound Option.** If you plan to add the sound option, mount a miniature ( $\frac{1}{8}$ " or 3.2-mm) phone jack in the playing field box next to the batteries and under the main pc board. Connect it to the sound option pads on the main board. A separate 9-volt battery is used to power the option. Suitable printed circuit etching and drilling, and parts placement guides are shown in Fig. 6. A 2" (5.1-cm) speaker is used. It can be taped or epoxied to the  $3\frac{1}{4} \times 2\frac{1}{8} \times 1\frac{1}{8}$  ( $8.3 \times 5.4 \times 2.9$ -cm) case top plate after it has been drilled and lettered. A miniature phone plug can be mounted directly in the bottom side of the case to mate with the playing field jack.

**Use.** Although it may appear to be easy to get a hit, advancing the League setting increases the difficulty. Only the basic rules for a hit, strike, foul, out, etc. must be understood before play can begin. You will soon notice how analogous Batter Up is to actual baseball in terms of pitcher strategy, batter's hand-eye coordination, and overall competitive spirit generated during play.

As with any other battery operated device, the game should be turned off when not in use to preserve battery life. When the LED's become dim and pitching cannot be initiated with the pitch switch, it is time to change the batteries.

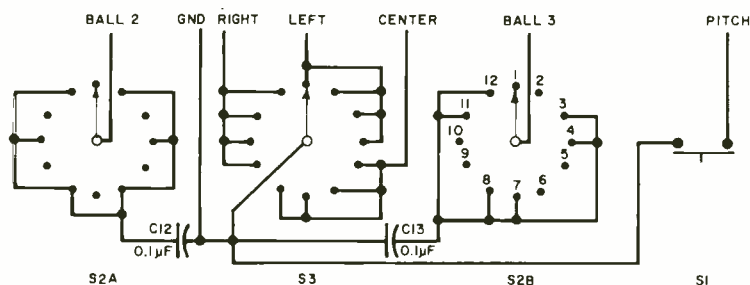

Fig. 5. Shown is switch wiring guide for Batter's Mound.

justs the "on" time for IC4-generated fast balls; slow balls still travel at the same speeds. The league selection allows everyone—from small children to the super-star—to play the game and be challenged by it.

A simple, but useful, option is an audible hit indicator. In Fig. 2, IC2 is an oscillator operating at about 2.5 kHz. Power is applied to the oscillator only when pin 3 of IC1 goes high. (Timer IC1 is a one-shot with an "on" time of about  $\frac{1}{4}$  second.) When a hit occurs, point C is grounded. This negative step is integrated to a pulse by C1 and C2, triggering IC1. When IC1 is on, the tone is heard from IC2 in the form of a  $\frac{1}{4}$ -second beep.

**Construction.** Batter Up has been configured as three separate enclosures: a pitcher's mound, a batter's box, and a playing field. Each enclosure is a standard Bakelite box. Printed-circuit construction makes assembly easy, but

the components could also be mounted on a perforated board. If you choose perf-board, you can use the components placement diagram as a guide.

The playing field box is  $7\frac{3}{4} \times 4\frac{3}{8} \times 2\frac{3}{8}$  ( $19.7 \times 11.1 \times 6$  cm). The top plate is drilled in accordance with the photo of the prototype. All lettering can be transfer type, while linework and figures can be made with an indelible-ink felt-tip pen. Once the marking is completed, a light coat of spray varnish will protect it from marring. All LED's can be mounted directly on the main pc board. Suitable etching and drilling, and component placement guides are shown in Fig. 3. The pc board is mounted in the box on machine-screw standoffs so that the LED's protrude about  $\frac{1}{8}$ " (3.2 mm) above the top plate. The battery holder is mounted under the pc board and the power switch on the side of the case. Two holes are drilled—one on each of the short sides of the case—for the wires going to the Batter's Box and Pitcher's Mound.

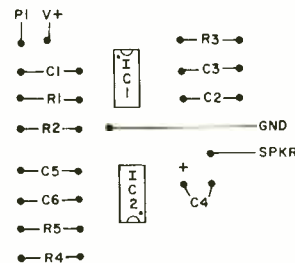
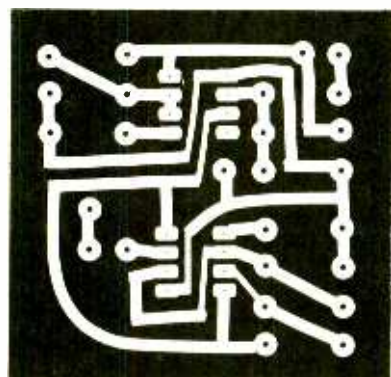

Fig. 6. Etching and drilling and parts placement guides for Sound Option.

# EVERY PROJECT IS ANOTHER REASON

Design and test circuits as fast as you can think — with CSC Proto-Board<sup>®</sup> Solderless Breadboards.

As quick as pushing in or pulling out components, you can design, test, and modify all kinds of circuits, with CSC Proto-Boards. Sockets are *already mounted*, on sturdy metal ground/baseplates with non-marring feet. They're great for a wide variety of audio and digital projects, and you save money by using components over and over again.

**PB-101**—940 solderless tie points: ten 14-pin DIP capacity. 140 five-point terminals plus 8 bus lines of 30 tie-points each. 4.5"W x 5.8"L x 1.4"H (114 x 147 x 35mm); 9 oz. (.26 Kg) Price: \$29.95

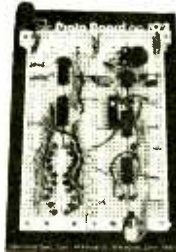

**PB-102**—1240 solderless tie points: twelve 14-pin DIP capacity. 188 five-point terminals plus 6 bus lines of 40 tie-points each and 2 bus lines of 30 points. 4.5"W x 7"L x 1.4"H (114 x 178 x 35mm); 10 oz. (.31 Kg). Price: \$39.95

**PB-6 Kit**—630 solderless tie points: six 14-pin DIP capacity. Economical way to get Proto-Board speed and convenience. 94 five-point terminals plus 4 bus lines of 40 tie-points. Comes with pre-assembled sockets, four 5-way binding posts, base-plate, all hardware. 10 minute assembly with pliers and screwdriver. 6"L x 4"W x 1.4"H (152 x 102 x 34mm); 7 oz. (.20 Kg). Price: \$15.95



**PB-100 Kit**—760 solderless tie points: ten 14-pin DIP capacity. 140 five-point terminals plus 2 bus lines of 30 tie-points each. Comes with pre-assembled sockets, two 5-way binding posts, base-plate, all hardware. 4.5"W x 6"L x 1.4"H (114 x 152 x 35mm); 7.5 oz. (.21 Kg). Price: \$19.95

## EXTRA LARGE CAPACITY FOR MORE COMPLEX CIRCUITS!

**PB-103**—2250 solderless tie points: twenty-four 14-pin DIP capacity. 354 five-point terminals plus 14 bus lines of 50 tie-points each, plus 2 bus lines of 40 points. 6"W x 9"L x 1.4"H (152 x 229 x 35mm); 1.25 lb. (.57 Kg). Price: \$59.95.



**PB-104**—3060 solderless tie points: thirty-two 14-pin DIP capacity. 472 five-point terminals plus 14 bus lines of 50 tie-points. 8"W x 9.8"L x 1.4"H (203 x 248 x 35mm); 1.75 lb. (.79 Kg). Price: \$79.95.

## Now, breadboard in any direction! With EXPERIMENTOR<sup>™</sup> sockets, the breadboarding system that gives you more flexibility for less dollars!

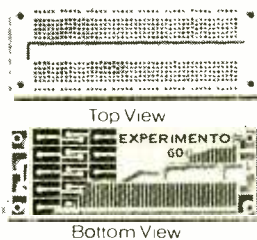

Arrange EXPERIMENTOR sockets to suit your circuit instead of rearranging your circuit to fit the breadboard.

Discover the ease and convenience of solderless breadboarding. CSC EXPERIMENTOR<sup>®</sup> sockets let you design, assemble and modify circuits as fast as you can push in or pull out components.

- **Large Capacity**—Large sockets have 550 solderless tie points (94 five-point terminals) plus two 40-point bus strips.
- **Full Fan-Out**—A CSC exclusive. The only solderless breadboard sockets with full fan-out capabilities for microprocessors and other larger (0.6") DIP's.

- **Snap-together in a domino pattern**—Arrange EXPERIMENTOR sockets to suit your circuit. Expand or contract at will.
- **Simple Mounting**—Vinyl insulated backing lets you mount EXPERIMENTOR sockets anywhere without shorting. Mount to any flat surface with 4-40 flat head screws or 6-32F self-tapping screws for behind-the-panel mounting.
- **Accepts All Standard Components**—Sockets conform to 0.1" grid and are DIP compatible. Accepts IC's, diodes, resistors, capacitors, transistors, etc. Use #22-30 solid AWG wire interconnections.

\*U.S. Pat. No. D235 554

All Prices Shown are Manufacturer's Recommended List. Prices and Specifications Subject to Change Without Notice.

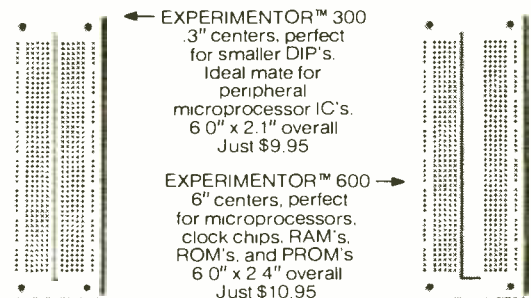

Model	SPECIFICATIONS			TIE POINTS			Price
	Length	Width	Center Channel	5 Tie Points Terminals†	Bus Strips†		
300	6.0"	2.1"	3"	94 (470)	2 (80)	\$9.95	
600	6.0"	2.4"	6"	94 (470)	2 (80)	\$10.95	
350	3.5"	2.1"	3"	46 (230)	2 (40)	\$5.50	
650	3.5"	2.4"	6"	46 (230)	2 (40)	\$6.25	
Quad	6.0"	0.75"	—	—	4 (160)	\$4.00	

Both units are .375" deep  
† Number in parentheses refers to total number of tie-points

CALL OR WRITE FOR FULL LINE CATALOG AND THE NAME OF YOUR CSC DEALER.

# IN THIS BOOK TO READ THIS AD.



## Proto-Boards with Built-In Regulated Power Supplies!

For extra  
convenience  
and  
breadboarding  
speed!

**PB-203**—Same capacity and layout as PB-103 plus short-proof, fused 5VDC 1A regulated power supply. Ripple and noise are a low 10mV at 0.5A. Has on-off toggle switch and pilot light plus four 5-way binding posts (2 for power). 9.75"L x 6.6"W x 3.25"H (248 x 168 x 83mm) weighs 5 lb (2.27 Kg). For 117VAC, 50/60Hz (220VAC available at slightly higher cost). Price \$80.00.

**PB-203A**—All PB-203 features plus separate regulated +15VDC and -15VDC, 0.5A supplies, with internally and independently adjustable output voltage. Same size as PB-203; 5.5 lb. (2.5 Kg). For 117VAC, 50/60 Hz (220VAC, 50/60 Hz at slightly higher cost). Price: \$129.95.

All Prices Shown are Manufacturer's Recommended List.  
Prices and Specifications Subject to Change Without Notice.

## LOGIC PROBE LP-1.

Compact, self-powered, multi-family probe with pulse stretching and latching (memory) capability for DTL, TTL, HTL, and CMOS.

By means of unique circuitry that combines the functions of a pulse detector, stretcher and memory, the LP-1 makes one-shot, low-rep-rate, narrow pulses—nearly impossible to see, even with a fast scope—easily detectable and visible. Input events—positive and negative level transitions, pulses, etc.—are automatically detected by the LP-1's specially-designed input circuits. Pulses as narrow as 50 nanoseconds are stretched to 1/3 second and by simply setting the PULSE MEMORY switch to the MEMORY position, single-shot as well as low-rep-rate events can be stored indefinitely.

To insure long trouble-free service, the LP-1 incorporates a rugged, high-impact plastic case, built-in strain relief power-cable, reverse polarity and over-voltage protection. Price \$44.95.

### HIGHLIGHTS

- HI and LO LED's blink on and off, tracking "1" and "0" states at square wave frequencies up to 100Hz.
- PULSE LED blinks on for 1/3 second during pulse trains.
- With square waves of up to 100KHz both HI and LO LED's will be activated. PULSE LED will blink continuously at 3Hz rate to indicate level transitions.
- With duty cycles of less than 30%, LO LED will light, in addition to PULSE LED blinking at 3Hz.
- With duty cycles of more than 70%, HI LED will light, in addition to PULSE LED blinking at 3Hz.
- Input impedance is 100,000 ohms for minimum circuit loading.
- Maximum input signal frequency is 10MHz.

## MEET MAX-100

CSC's 100 MHz 8-digit Audio /CB /RF/Digital counter. At \$134.95, nothing else does so much for so little.

- \* MAXimum frequency range—20Hz-100MHz
- \* MAXimum CB performance—ideal for CB applications
- \* MAXimum visibility—big, bright, 0.6" 8-digit LED display
- \* MAXimum accuracy—crystal-controlled timebase
- \* MAXimum operating ease—automatic, no controls to set
- \* MAXimum range of applications—use for audio through ultrasonic through RF: AM, FM and digital
- \* MAXimum portability—completely self-contained
- \* MAXimum versatility—use with clip-lead cable, in-line tap, mini-whip antenna, etc.
- \* MAXimum flexibility—choice of four power sources



MAX-100 is a portable, high-precision frequency counter that sets new standards in performance and value. In a compact, portable case, it gives you *continuous readings* from 20Hz to a *guaranteed 100MHz*, with 8-digit accuracy. Fast readings with 1/6-sec. update and 1-sec. sampling rate. Precise readings, derived from a crystal-controlled time base with 3ppm accuracy. High-sensitivity readings from signals as low as 30 mV, with diode overload protection up to 200V peaks.

Input signals over 100MHz automatically flash the most significant digit. And to indicate low-battery condition and extend remaining battery life, the *entire* display flashes at 1 Hz. Price: \$134.95

## SPECIFICATIONS

**Range:** 20 Hz to 100 MHz, guaranteed **Gate time:** 1 sec.  
**Resolution:** 1 Hz **Accuracy:** ± 1 count + time base error.  
**Input Impedance:** 1 MΩ/56pF **Coupling:** AC. **Sine Wave Sensitivity:** 30 mVRMS @ 50 MHz **Internal Time Base Frequency:** 3 579545 MHz x tal osc. **Stability:** ± 3 ppm @ 25°C **Temp-Stability:** Better than 0.2 ppm/°C. 0-50°C  
**Max. Aging:** 10 ppm/year **Display:** Eight, 6" LED digits.  
**Lead-zero blanking:** decimal point appears between 6th and 7th digit when input exceeds 1 MHz. **Overflow:** with signals over 99,999,999 Hz, most significant (left hand) digit flashes, allowing readings in excess of 100 MHz. **Display update:** 1/6-second plus 1 sec. gate time **Low Battery Indicator:** When power supply falls below 6.6 VDC, all digits flash @ 1 Hz  
**Power:** 6 AA cells (internal). **External:** 110 or 220 VAC Eliminator/charger. Auto cigarette lighter adapter; 7.2-10VDC ext. supply. **Bat. Charging:** 12-14hr **Size (HWD):** 1.75" x 5.63" x 7.75" (4.45 x 14.30 x 19.69cm.) **Weight:** Less than 1.5 lb. (0.68Kg) w/batteries

CONTINENTAL SPECIALTIES CORPORATION



70 Fulton Terrace, Box 1942, New Haven, CT 06509  
203-624-3103 TWX 710-465-1227  
West Coast: 351 California St., San Francisco, CA 94104  
415-421-8872 TWX 910-372-7992

# THREE-WAY POWER SUPPLY

*Two 0-15 volts at 750 mA and one 50 volts at 1 ampere supplies have both voltage and current limiting.*

BY J.R. LAUGHLIN

HERE IS a power supply package incorporating a number of features which make it not only unique but extremely useful. First of all, the package includes three separate power supplies. Two of these are identical and are designed to supply independent operating voltages for transistor and integrated circuits—one can be used as the positive supply, the other negative. Each has an output capability of up to 15 volts at 0.75 ampere, and the adjustable output voltage is regulated to 0.1% or better. These two supplies are completely isolated from one another, which makes it possible to stack them for higher output voltage or to operate them at different ground levels. (Parallel operation of the two supplies is not recommended since the very least voltage difference between them causes undesirable interaction between the two.) The supplies are generously over-rated and can be operated at maximum capacity on a continuous basis without overheating.

The third supply is similar to the other two except that it has a higher output voltage and current capabilities. This supply is also very well regulated, is adjustable, and will supply up to 50 volts at one ampere. The lower limit of voltage output is approximately 8 V. This characteristic is intrinsic in the design. No attempt was made to incorporate an adjust-to-zero output capability because of the added complexity and lack of need to operate very near zero. (The minimum output of the other two supplies is about 1.5 V.) This supply is handy for performing odd jobs in conjunction with the circuit under test, such as powering a small motor, heater, etc. or part of the circuit that requires higher power. It can also be used as a battery charger at 24 or 36 volts.

All three supplies have adjustable current-limiting circuits and output-voltage limiting capability. The current limiting can prevent destructive conditions in case of accidental shorting or overloading of a circuit. This feature also lends itself to operation of the supplies as constant-current sources, with the current level being adjustable over a wide range. Over-voltage limiting was added as a result of the destruction of IC's due to adjustment of previous supplies to too high a voltage level.

Each supply has its own meters for continuously monitoring its voltage and current output so there is no need

to switch back and forth. The current meters are dual-range due to the wide range of currents available. Each supply also has an indicator light that goes on when either current or over-voltage limiting occurs.

**Circuit Operation.** The two low-voltage supplies are identical, using an integrated circuit as the regulating device (Fig. 1). The IC drives a power transistor,  $Q4$ , to provide the output current. The IC contains a very stable voltage-reference source and a sensitive error-detecting amplifier. Regulation is accomplished by comparing the output to the reference and any discrepancy is corrected by the error amplifier. Adjustment of the output voltage is accomplished by varying the amount of the output that is fed back to the error amplifier (pin 4) through  $R17$ . The reference voltage is on pin 6 of the IC. It is divided by  $R2$  and  $R3$  and applied to the second input to the error amplifier (pin 5).

Current output level is monitored by  $Q1$  with feedback through  $R7$ . The setting of  $R15$  determines the amount of feedback. When the feedback is sufficient for  $Q1$  to turn on, a signal is supplied to pin 2 of the integrated circuit to adjust the output.

Voltage output is monitored by  $Q2$  with feedback through  $R9$ . The setting of  $R16$  determines the amount of feedback and when it is sufficient to turn on  $Q2$ ,  $Q1$  also turns on, supplying the limiting signal to the IC. Whenever this signal is supplied to the IC, it sends a signal to the base of  $Q3$ , which turns on limiting indicator  $I1$ .

Instead of an IC, the high-voltage supply uses transistors throughout (Fig. 2). The voltage reference is provided by zener diode  $D2$ . Comparison of the reference to the output level from  $R15$  is made by  $Q2$ . The current output is monitored by  $Q4$  with feedback determined by  $R17$ . If  $Q4$  is turned on,  $Q5$  is turned on to change the output (through  $Q3$ ) and also to

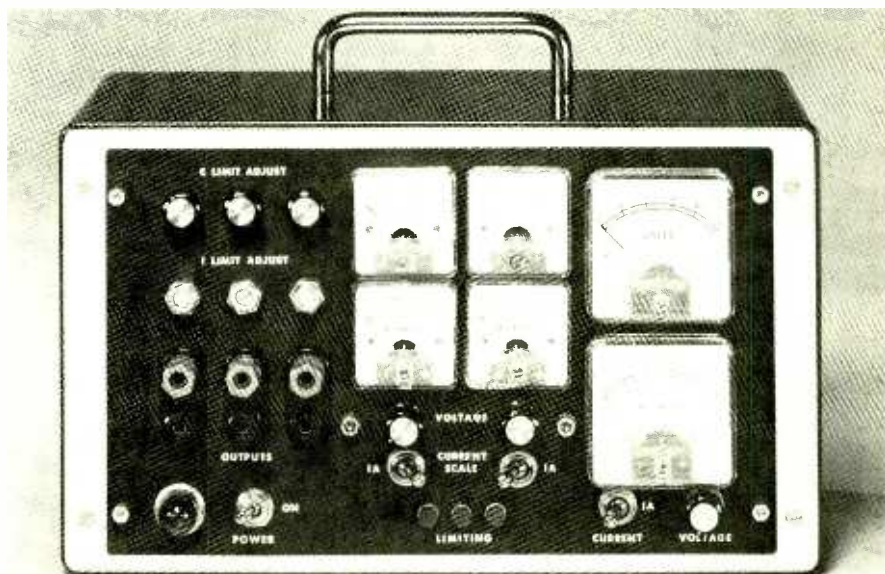



## PARTS LIST\*

- C1—10- $\mu$ F, 20-volt electrolytic capacitor
- C<sub>1/4</sub>—0.01- $\mu$ F ceramic capacitor
- C3—100-pF ceramic capacitor
- C4—4- $\mu$ F, 20-volt electrolytic capacitor
- C5—20- $\mu$ F, 20-volt electrolytic capacitor
- I1—28-volt, 40-mA lamp (Dialco 507-3917-1471-600 or similar)
- IC1—IC voltage regulator (723)
- J1, J2—5-way connector (red, black)
- M1—100-mA meter (Monarch PMC75 or similar)
- M2—0-15-volt meter (Monarch PMC115 or similar)
- Q1—Transistor (HEP715, 2N5367)
- Q2—Transistor (HEP709, 2N5249)
- Q3—Transistor (HEPS9100, 2N5308)
- Q4—Transistor (HEP703, 2N3055)
- Resistors—All 1/2-watt, 10% tolerance unless otherwise noted.
- R1, R3—1500-ohm
- R2—3900-ohm
- R4, R5, R7, R9—1000-ohm
- R6—22,000-ohm
- R10—100-ohm
- R11—470-ohm
- R12—1-megohm
- R13—0.3-ohm
- R14—Meter shunt (see text)
- R15—10-ohm wirewound potentiometer
- R16—250,000-ohm carbon potentiometer
- R17—10,000-ohm, 10-turn potentiometer
- S1—Spst switch
- \*Two of each required

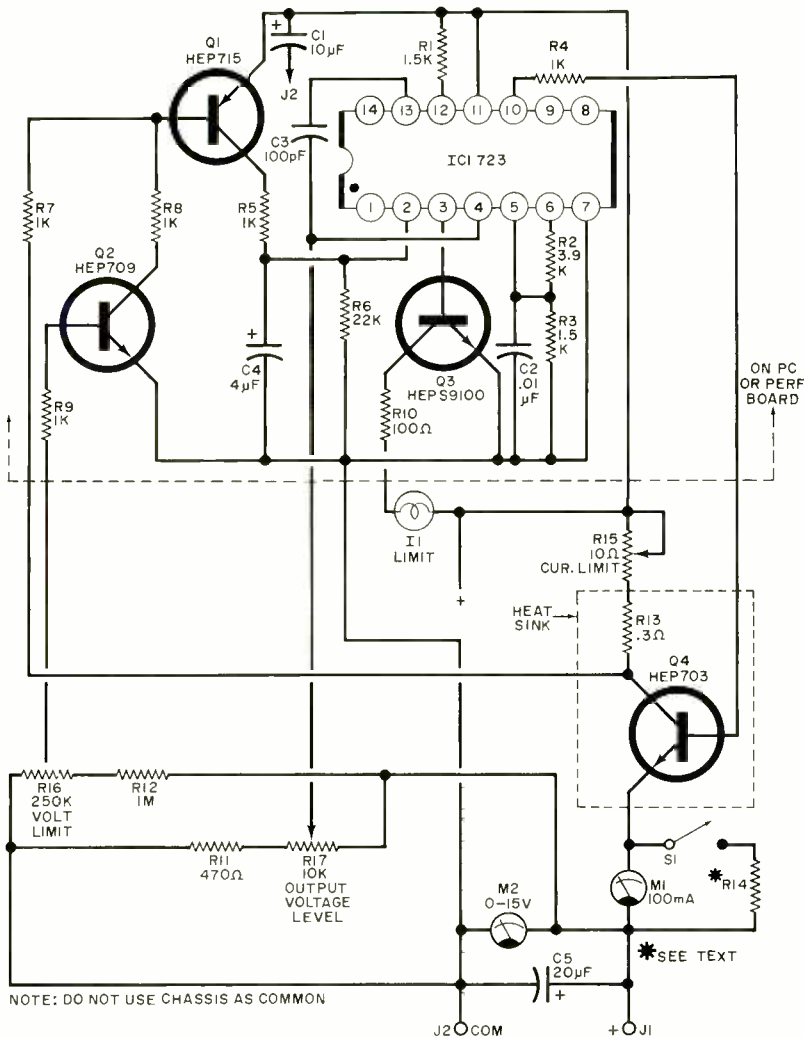

Fig. 1. Low-voltage supply (of which there are two) uses an IC regulator. Automatic voltage and current limiting circuits activate the indicator lamp I1.

turn on Q6 and energize the indicator light. Voltage output is monitored by Q7 with feedback from R16. When Q7 turns on, Q4 turns on as for current limiting.

Conventional transformer and full-wave rectifier circuits are used to power each supply as shown in Fig. 3. The individual transformers provide complete isolation between the supplies. Note that each supply is independent and their commons are not connected to chassis ground.

**Construction.** Any type of enclosure can be used for the three-way supply. In this case a Bud CU-7127 cabinet was used and the bottom plate was constructed of 1/8" aluminum, drilled for the three large capacitors. The power supply rectifiers were mounted on their own small board under the bottom plate. In the prototype a two-sided PC board was used for the electronics of all three supplies. The board was mounted in an 18-pin double readout card connector. It might be preferable to assemble each regulator on a separate board for ease of con-

struction, installation, and future maintenance.

The rear-panel heat sink should be made of aluminum at least 1/8" thick and preferably 1/4". The output transistor for the high-voltage supply was mounted on a separate heat sink at-

tached to the rear panel to increase the surface area.

The current meters require shunts for 1-ampere operation (R12 and R14). These shunts can be wound easily by hand using #28 enameled copper wire and a 1-watt carbon resistor (any val-

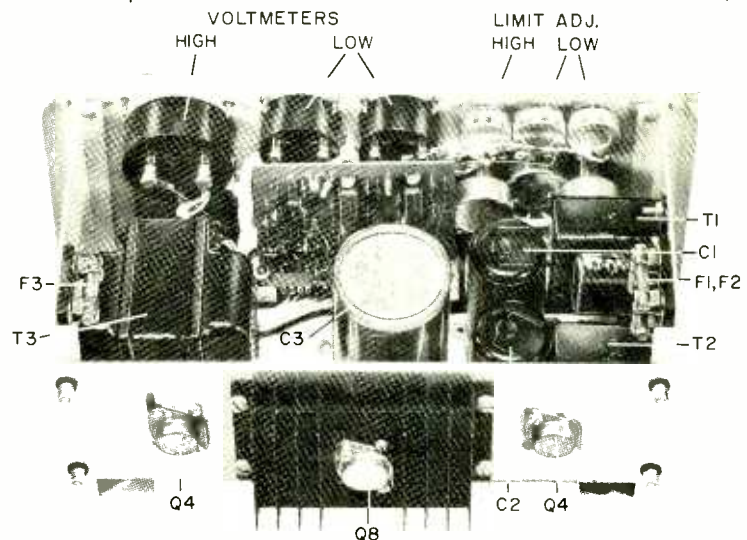

Arrangement of component in prototype of triple power supply. Three electronic regulators are mounted on double-sided circuit board.

## PARTS LIST

- C1,C2—10- $\mu$ F, 20-volt electrolytic capacitor  
 C3—20- $\mu$ F, 50-volt electrolytic capacitor  
 D1—15-volt zener diode (HEPZ0225)  
 D2—6-volt zener diode (HEPZ0214)  
 I1—28-volt, 40-mA lamp (Dialco 507-3917-1471-600 or similar)  
 J1,J2—5-way connector (red, black)  
 Q1—Transistor (HEPS9100, 2N5308)  
 Q2,Q5-Q7—Transistor (HEPS0001, 2N5550)  
 Q3—Transistor (HEPS3021, MPSU03)  
 Q4—Transistor (HEP710, 2N5400)  
 Q8—Transistor (HEP241, 2N5069)  
 Resistors—All  $\frac{1}{2}$ -watt, 10% tolerance unless otherwise noted.  
 R1,R2—3300-ohm  
 R3,R8-R10—1000-ohm  
 R4-R6—10,000-ohm  
 R7—470-ohm, 1-watt  
 R11—0.3-ohm  
 R12—Meter shunt (see text)  
 R13—270,000-ohm  
 R14—470-ohm  
 R15—10,000-ohm, 10-turn potentiometer  
 R16—10,000-ohm carbon potentiometer  
 R17—10-ohm wirewound potentiometer  
 S1—Spst switch

Fig. 2. The 50-volt supply is all transistor and also has current and voltage limiting.

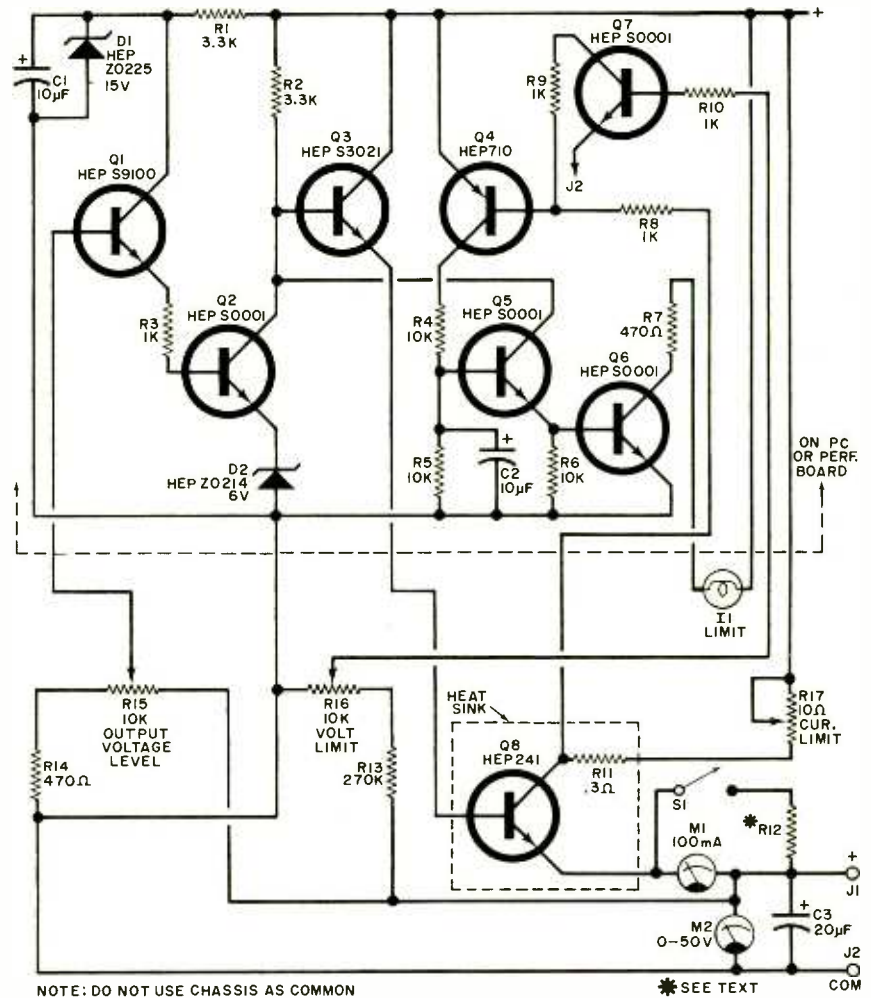

ue) for the form. Of course, shunts can be purchased for most high-quality meters, but it is possible to wind the shunts for less expensive models.

The ammeter shunts should be

mounted directly from the ammeter terminals to the shunt switch terminals. The 0.3-ohm resistors (R11 and R13) can be mounted on the bases of the transistor sockets.

The C5 capacitors in the low-voltage supplies and C3 in the high-voltage supply should be mounted directly on the output binding post behind the front panel. Use tie-points to hold R11 and R12 in the low-voltage supplies and R13 and R14 in the high-voltage supply.

**Checkout.** Check the rectifier circuits before connecting all the rest of the circuits. If the rectifiers are all right, connect the regulator circuits.

It is strongly suggested that, when first testing the high-voltage supply, a Variac (or similar source) be used to provide a low voltage input at the start.

An oscilloscope should be used to detect any tendency of the supplies to oscillate. This should be done at several current and voltage output levels. Regulation can be observed by using various values of load resistors on the supplies. The low-voltage supplies should regulate to within about 0.2% or better from zero to full load. The current-limiting circuit will hold the output current to the preadjusted level regardless of the value of the load. ♦

ELECTRONIC EXPERIMENTER'S HANDBOOK

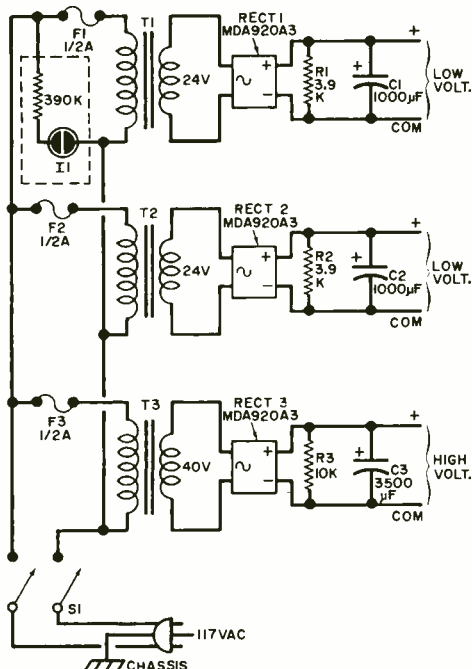

Fig. 3. The three independent power supplies are conventional bridge-rectifier circuits.

## PARTS LIST

- C1,C2—1000- $\mu$ F, 50-volt electrolytic capacitor  
 C3—3500- $\mu$ F, 75-volt electrolytic capacitor  
 F1-F3— $\frac{1}{2}$ -ampere 3AG fuse and holder  
 I1—117-volt neon lamp assembly  
 RECT1-RECT3—MDA920A-3 bridge rectifier  
 R1,R2—3900 ohm, 2-watt resistor  
 R3—10,000-ohm, 1-watt resistor  
 S1—Dpst switch  
 T1,T2—Transformer, 24-V, 1-A (Triad F46X or similar)  
 T3—Transformer, 40-V, 1-A (Triad F92A or similar)  
 Misc.—Suitable cabinet (Bud CU7127 or similar), aluminum panel  $\frac{3}{16}$ " thick (Bud PA3102 or similar), heat sink  $3" \times 4" \times 1"$ , mounting hardware, line cord, power transistor insulators, terminal strips, capacitor mounts, knobs, etc.



# NRI CAN TURN YOUR CB INTEREST INTO PART-TIME INCOME OR A CAREER

## Career opportunities are opening up fast for the man trained in communications.

The field of communications is bursting out all over. In Citizens Band alone, class "D" licenses grew from 1 to over 2.6 million in 1975, and the FCC projects about 15 million U.S. CB'ers by 1979. That means a lot of service and maintenance jobs . . . and NRI can train you at home to fill one of the countless career jobs available in design, installation and maintenance of communications equipment. Start training now, the NRI way, to get your all important FCC Radiotelephone License and qualify for one of these openings.

## Learn on your own 400-channel, digitally-synthesized VHF transceiver

The NRI Complete Communications Course teaches you at home to service and adjust all types of two-way radio equipment (including CB), using the one unit that is best equipped to train you for CB, Commercial and Amateur communications: a digitally-synthesized 400-channel VHF transceiver

and AC power supply. This 2-meter transceiver gives you "Power-On" training. Then we help you get your FCC Amateur License with special instructions so that you can go on the air.

## More know-how for your dollar

The complete program includes 48 lessons, 9 special reference texts, and 10 training kits. Included are: your own electronics Discovery Lab, a new Antenna Applications Lab, an Optical Transmission System, CMOS Digital Frequency Counter, and TVOM. The course covers AM and FM Transmission Systems; Radar Principles; Marine, Aircraft, and Digital Electronics; and Mobile Communications. You must earn your first class radio-telephone FCC license or you get your money back.

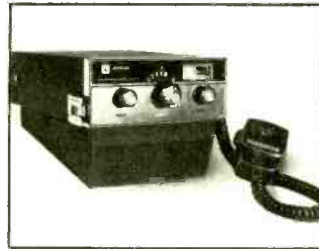

## CB Specialist Course also available

NRI offers a specialized course in CB Servicing. You get 37 lessons, 8 reference texts, your own CB transceiver, AC power supply and multimeter . . . for hands-on training. Also included are 14 coaching units to make it easy to get your commercial radiotelephone FCC license, enabling you to test, install and service communications equipment.

## Widest choice of courses with Quadraphonic Audio and Color TV Servicing

NRI offers five TV-Audio servicing courses as well as career courses in Digital Computer Electronics; Marine and Aircraft Electronics; Mobile Communications, and more.

## Over a Million have enrolled with NRI

Send for the free NRI catalog and discover why more than a million people like yourself have chosen the NRI way as the right way to get ahead. Read how you learn at home from bite-size lessons, progressing at your own speed to your FCC license and then into the communications field of your choice. There's no obligation, and no salesman will call.



If card is missing, write to:

**NRI**  
McGraw-Hill  
NRI SCHOOLS  
McGraw-Hill Continuing  
Education Center  
3939 Wisconsin Avenue  
Washington, D.C. 20016

# HOW TO PROGRAM READ-ONLY MEMORIES

*An experimenter's guide to programmable ROM's—  
what they are and practical applications for them.*

BY ROBERT D. PASCOE

**P**ROGRAMMABLE read-only memories are unique among the digital integrated circuits readily available to experimenters. What makes it unique is that it is user programmable. You decide what you want the PROM to do and program it to do just that. The only "tools" you need are a pair of regulated power supplies, some switches, and a resistor. The programming procedure itself is outlined later on in this article.

The PROM is one member of the standard ROM family of memories. Once it is programmed, its memory is nonvolatile, which means that, if power is removed from and then reapplied to the PROM, the stored information remains intact. By contrast, a RAM (random-access memory) has a volatile memory: if power is interrupted, when it is again applied, whatever information was stored in the memory will be erased.

The ROM (and PROM) can be made from bipolar transistors, in which case it is called a bipolar ROM. It can also be made from metal oxide semiconductor devices, which makes it a MOS-ROM. Whichever type it is, the ROM is a digital device that "remembers" information on the standard binary format of 1's and 0's. The logic levels remembered by the bipolar

ROM are the same as those used in TTL circuits, whereas the levels remembered by the MOS-ROM are determined by the supply voltage required by the device itself.

**Organization.** An important characteristic of the ROM is its organization. The ROM remembers quantities of binary "bits" that are organized into "words." Each word has a certain number of bits. For example, one type

of ROM can remember 256 bits of information organized into 32 words of eight bits apiece (32 words  $\times$  8 bits = 256 bits).

Some of the more commonly available ROM's can remember 256, 1024, 2048, or 4096 bits in a single IC chip. With the various types of ROM's, the manufacturer determines how the total number of bits is organized in the chip.

The organization of the bits deter-

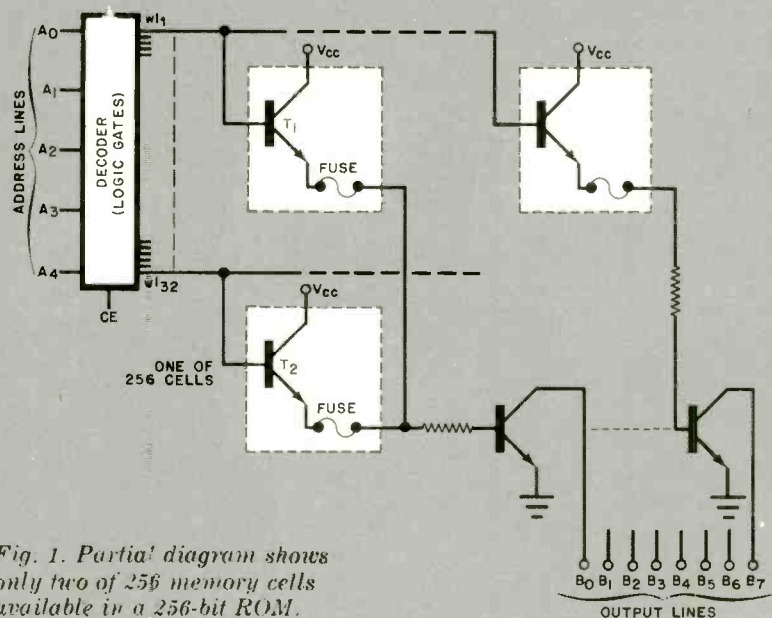

*Fig. 1. Partial diagram shows only two of 256 memory cells available in a 256-bit ROM.*

## SOME APPLICATIONS FOR PROM'S

**T**HERE are countless applications for the ROM. Some of the more traditional ones use the ROM as lookup-table (trigonometry, logarithms, etc.) memories in calculators; as micro-instruction systems in computers; and character generators for displaying alphanumeric characters on a CRT screen. The following are examples of what you can do with an 8223 PROM:

**Character Generator.** A seven-segment display device can be used to create the numerals 0 through 9, a number of upper- and lower-case letters of the alphabet, and some mathematical punctuation—all with a single 8223 PROM chip. Because the display has only seven segments, it cannot form all 52 upper- and lower-case or even all 26 upper- or lower-case letters.

In Fig. A is shown the logic diagram for an alphanumeric/punctuation generator. Beside it is the "truth table" we used for generating the 32 possible characters. Note that the entire memory storage capability is "used up" in this truth table. (This truth table

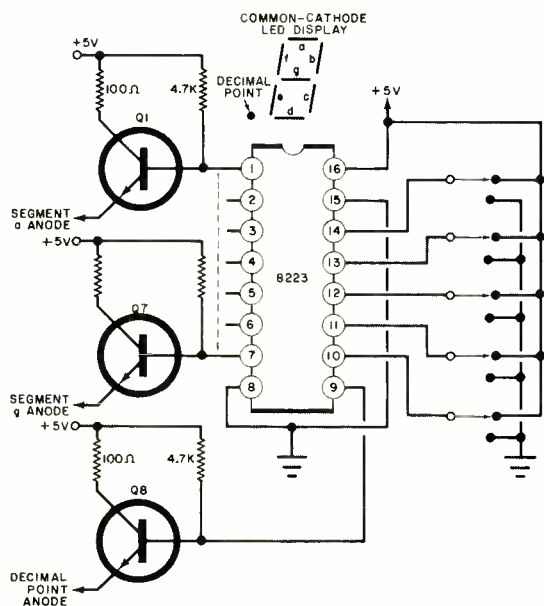

Fig. A. Once PROM is programmed according to truth table at right, it can generate numbers, letters, etc., on 7-segment display device.

assumes a buffering transistor between the outputs of the 8223 and segments of the display. The display can be either an RCA 2100 incandescent or common-anode LED display. For common-cathode LED displays, all  $B_{10}$  through  $B_7$  logic levels must be reversed.)

All eight output lines from the 8223 PROM are used, with one output assigned to each segment of the display and a final one for

Figure Displayed	Address ( $A_4-A_0$ )	Outputs ( $B_7-B_0$ )	Segments on
0	00000	00111111	abcdef
1	00001	00000110	bc
2	00010	01011011	abdeg
3	00011	01001111	abcdg
4	00100	01100110	bcfg
5	00101	01101101	acdfg
6	00110	01111101	acdefg
7	00111	00000111	abc
8	01000	01111111	abcdefg
9	01001	01101111	abcdefg
.	01010	10000000	decimal point
-	01011	01000000	g
=	01100	01001000	dg
A	01101	01110111	abcefg
b	01110	01111100	cdefg
C	01111	00111001	adef
c	10000	01011000	deg
d	10001	01011110	bcdeg
E	10010	01111001	acdefg
F	10011	01110001	aefg
G*	10100	00111101	acdef
H	10101	01110110	bcefg
h	10110	01110100	cefg
i*	10111	00010000	e
J	11000	00011110	bcde
L	11001	00111000	def
n*	11010	01010100	ceg
o	11011	01011100	cdeg
P	11100	01110011	abefg
r*	11101	01010000	eg
U	11110	00111110	bcdef
u	11111	00011100	cde

\*These letters are only approximations, included only to use up the PROM's program capability.

mines the number of address (input) and output lines that will be available in a given ROM. Address input pins are the means by which a specific word in the memory is accessed or selected. If a particular ROM is organized with 32 words of eight bits per word, each word can be addressed with five input address lines ( $2^5 = 32$ ). The address 00000 would be for word one, 00001 for word two, 00010 for word three, and so on until 11111 would be for word 32. The number of output pins for a small memory is determined by the number of bits used per word in the memory's organization. In our example, the ROM would have eight output pins.

The address lines for a ROM are usually denoted by the legends  $A_{10}$ ,  $A_9$ ,  $A_8$ , etc., while the output lines would

be denoted by  $B_{10}$ ,  $B_9$ ,  $B_8$ , etc. For a five-address-line input and eight-line output ROM, the address pins would be labelled  $A_4$ ,  $A_3$ ,  $A_2$ ,  $A_1$ , and  $A_0$ , and the output pins would be labelled  $B_7$ ,  $B_6$ ,  $B_5$ ,  $B_4$ ,  $B_3$ ,  $B_2$ ,  $B_1$ , and  $B_0$ .

Illustrated in Fig. 1 is a basic 256-bit (32-word by eight-bit) bipolar ROM. The address lines are fed to logic gates that decode the 32 possible combinations of 1's and 0's that appear on the five address lines. These 32-word lines are denoted by the legends  $w_1$  through  $w_{32}$ . For the particular ROM shown, there are eight output transistors whose collectors are labelled  $B_0$  through  $B_7$ . The memory "cells" are denoted by the legends  $T_1$  and  $T_2$ . There are 256 of these basic memory cells for a 256-bit ROM.

The output lines from the ROM

would be either high (logic 1) or low (logic 0), depending on whether or not a conduction path exists between the memory cell and the output transistor in each line. As an example, if a 0 is to be stored at  $B_0$  in word 32, the  $T_2$  resistance link (fuse symbol) must be present. If, on the other hand, a 1 is to be stored at  $B_0$  of word 32, the fuse must be electrically removed (blown) from the circuit.

Most ROM's have a pin labelled CE, for "chip enable," that permits the output to be isolated from the rest of the circuitry inside the IC. So, if a 1 is placed at CE (while the address is being changed), the outputs will be at the logic-1 level. The placement of this specific binary information into the ROM is called "programming." The means of programming is determined

the decimal point. To use up the entire storage capability of the PROM, the entire 00000 through 11111 series was used on the address lines ( $A_0$  through  $A_4$ ). We will discuss later how to perform the actual "programming" procedure for the PROM.

An extension of the single-character generator is the word generator. Here, we have several PROM's and an equal number of displays, each programmed with identical information. Depending on the number of PROM's and displays desired, this system can be used to generate words, strings of numbers, identification and license numbers, etc. You simply set the address lines of each PROM to generate the character you want.

**Model RR Track Patterns.** The PROM can also help an HO model railroader remember track patterns for his train layout. As an example, suppose an HO train layout has eight track switches and 10 possible track configurations. A PROM can be used to remember the positions of the various switches for the 10 possible track patterns, as shown in Fig. B. The outputs of the PROM would be connected to the track switches through electronic switches (driver transistors). This ensures that the output voltage levels of the PROM are converted to the proper voltages and currents needed to move or position the track switches.

The PROM must be programmed with the appropriate binary codes. The words  $w_1$  through  $w_{10}$  can then be the various track patterns that the train can have. The one-shot multivibrator's output is coupled to the CE input of the PROM so that the switches do

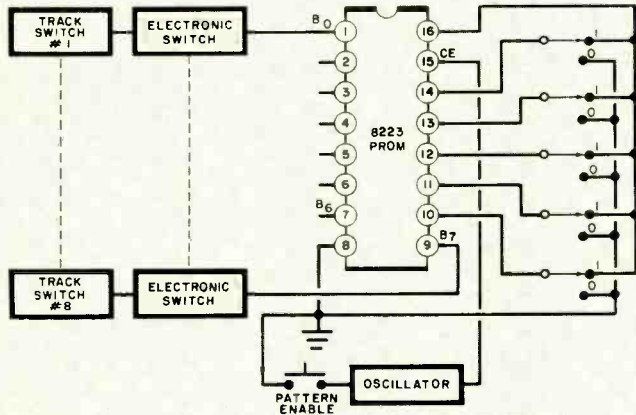

Fig. B. In model-railroad system, PROM would be programmed to control all possible combinations of switches on track.

by the type of ROM. The two major types of ROM's are the custom-programmed and the field-programmable ROM.

With custom-programmed ROM's, the manufacturer places the binary information (links or no links) into the memory as specified by the user. Custom programming of ROM's can be very expensive when only small quantities are ordered. To reduce the high cost of small quantities of ROM's, manufacturers offer the field-programmable ROM or PROM.

The PROM is an ordinary ROM that has all of its on-chip fuses intact. A 256-bit PROM would have 256 of these fuses, one for each bit of memory. The user can program information into the PROM simply by blowing selected on-chip fuses. The fuses are blown

open by passing a specific amount of current through them for a specified period of time. (The Signetics 8223 is an example of a 256-bit PROM. It is readily available from a number of surplus-parts suppliers for about \$3.00. This PROM is organized into 32 words of eight bits per word.)

**Erasable PROM's.** ROM's are usually thought of as having permanent binary information programmed into their memories. Once information is programmed into an ordinary ROM, it cannot be altered. Recently, however, a new type of PROM—the erasable PROM—has become available. This type of PROM permits information stored semi-permanently to be erased and new information to be programmed in.

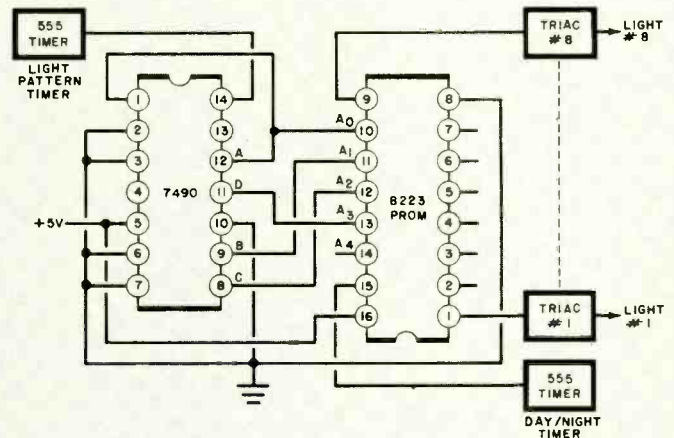

Fig. C. Clocked by timer circuit, 7490 counter delivers a 4-bit input to PROM, which controls triacs to turn lights on and off.

not have voltage across their coils continuously. With the PROM remembering the various track positions for the eight switches, you need only select the pattern you wish and push a button to initiate the selection of that pattern.

**Intruder Deterrent.** When you go away from home for a day or longer, you probably use mechanical timers to turn on and off house lights to make it appear that someone is home. A PROM can be used for this purpose and is much more effective in deterring intruders than are mechanical timers.

Shown in Fig. C is a system, built around a PROM, for turning on and off house lights in a certain sequence. Suppose that there are eight lights located throughout the house. The lights can be controlled by individual triacs, with the triacs controlled by the outputs from the PROM.

Assume that 10 light patterns are to be used in the evening hours. Word one can be a basement and a living room lights-on command, word two can be a living room and a kitchen lights-on command, and so on.

The various patterns of lights (words) can be selected by changing the address inputs, which are connected to a 7490 decade counter. A 555 timer can be used to change the outputs, of which there are a possible 10, of the 7490. This, in turn, changes the lighting sequence for the house. With this arrangement, various lights in the house can be changed every so often to give the appearance that someone is home and moving from room to room.

One type of erasable PROM, the 2048-bit MM5203, is made by National Semiconductor Corp. It can be erased by concentrated shortwave ultraviolet light. (It is available, surplus, for about \$9.00. The MM5203 is housed in a 16-pin dual in-line package (DIP) with a quartz top that is transparent to shortwave UV light. The 2048 bits are organized as either 256 words of eight bits per word or 512 words of four bits per word.

The advantage of the erasable PROM, as opposed to the nonerasable PROM, is that it can be used over and over again for different programs. The unwanted information is simply erased by directing UV light through the IC's quartz "window" and reprogramming as desired.

Another type of erasable PROM

## PREPARING A PROGRAMMING AND ADDRESSING TRUTH TABLE FOR PROM'S

Because the PROM is a logic element, programming and addressing it must conform to the rules of logic. To do this, a truth table must be drawn up for the programming procedure. This same truth table is also used for addressing the ROM after programming has taken place so that stored information can be retrieved.

There are two approaches you can use when working up your truth table. The first is an arbitrary table, used mainly for demonstration purposes. Since you would key in the address codes by manually setting switches, you can use any address system that suits your fancy. The truth table accompanying the diagram in Fig. A is an example of the arbitrary approach.

For more practical applications, address code selection would be under the control of the digital system in which the PROM is to be used. In this case, the programming truth table for both input and output codes must conform to those required by the system. A typical example is a BCD-to-7-segment decoder.

Let us assume a 7490 decade counter's encoded output is to be used to drive a seven-segment LED display. All decoding can be accomplished with a PROM. The PROM will then feed inverter/buffer transistors, which in turn will power the display's segments. The truth table, with the 7490's DCBA output lines feeding the 8223's  $A_3, A_2, A_1, A_0$  address lines respectively, would be:

$A_3, A_2, A_1, A_0, B_7, B_6, B_5, B_4, B_3, B_2, B_1, B_0$

NO.	D	C	B	A	g	f	e	d	c	b	a
0	X	0	0	0	X	0	1	1	1	1	1
1	X	0	0	0	1	X	0	0	0	0	1
2	X	0	0	1	0	X	1	0	1	1	0
3	X	0	0	1	1	X	1	0	0	1	1
4	X	0	1	0	0	X	1	1	0	0	1
5	X	0	1	0	1	X	1	1	0	1	0
6	X	0	1	1	0	X	1	1	1	1	0
7	X	0	1	1	1	X	0	0	0	0	1
8	X	1	0	0	0	X	1	1	1	1	1
9	X	1	0	0	1	X	1	1	0	1	1

The DCBA in the heading represents the outputs from the 7490, while the gfedcba represents the display segments controlled. The X's are don't-care states, since there is no input to the  $A_3$  input nor output termination for the  $B_7$  output lines of the 8223 PROM.

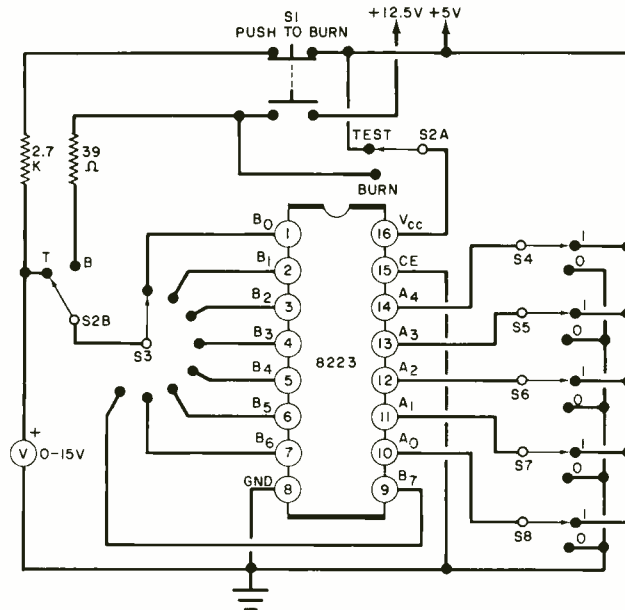

Fig. 2. In this programming setup, both power supplies must be regulated. Once PROM is programmed, its memory can be checked as described in the text.

—this one not so readily available to experimenters—is the Nitron Company's NC7010 EAROM. This device can be erased electrically in one second. It can be erased and reprogrammed up to a million times. The NC7010 is organized as 512 words of two bits per word.

**How to Program a PROM.** The 8223 PROM used in the applications described is shipped with all of its outputs at a logic-0 level. This means that all of its on-chip fuses are intact. If a logic 1 is to be written into the PROM's memory, the fuses must be blown. The procedure for blowing selected fuses is called programming. It can be performed with the circuit shown in Fig. 2. The +5- and +12.5-volt power supplies must be regulated. Switch  $S1$  is a two-circuit push-button switch, with one set of contacts normally open and the second set normally closed. Switch  $S2$  is a dpdt slide or toggle switch, while switch  $S3$  must be a non-shorting rotary switch with eight or more positions.

After wiring together the Fig. 2 circuit, program the PROM as follows:

1. Set  $S2$  to the BURN position. (Note: Never operate  $S1$  when  $S2$  is set to BURN.)
2. Feed the proper logic-1 (+5-V) and logic-0 (0-V or ground) code for word one onto address lines  $A_3$  through  $A_0$  via  $S4$  through  $S8$ .
3. Set  $S3$  to the first PROM output line position in which a fuse is to be blown according to your programming truth table.

4. Depress  $S1$  for about a half second and release. This action, in blowing the fuse, develops considerable localized on-chip heat; so, **do not depress  $S1$  for longer than a full second.**

5. Allow several seconds of cooling down time for the chip.

6. Set  $S3$  to the next output line in which a fuse is to be blown.

7. Repeat steps 4 and 5 for each output line in which a fuse is to be blown.

8. Set  $S4$  through  $S8$  for the logic required for word two.

9. Repeat steps 3 through 7.

10. Continue to address the PROM for each succeeding word, repeating steps 3 through 7 as you proceed from word to word, until you have completed programming the PROM.

The schematic diagram shown in Fig. 2 depicts a program and test circuit. As you finish steps 3 through 7 for each word, set  $S2$  to TEST (do not change the address code yet) and, observing the meter, check the PROM's outputs by cycling through  $S3$ 's positions. Logic 0 will be indicated by the pointer swinging to near the scale's zero index, while logic 1 will be indicated by about a +5-volt reading. Once you have verified that the program has "taken" for a given word, set up the circuit for programming into the PROM's memory the next word that you want.

After making sure that the PROM is properly programmed, affix some identifying code on its case and truth table and file away the latter in a safe place where it will not get lost. ♦

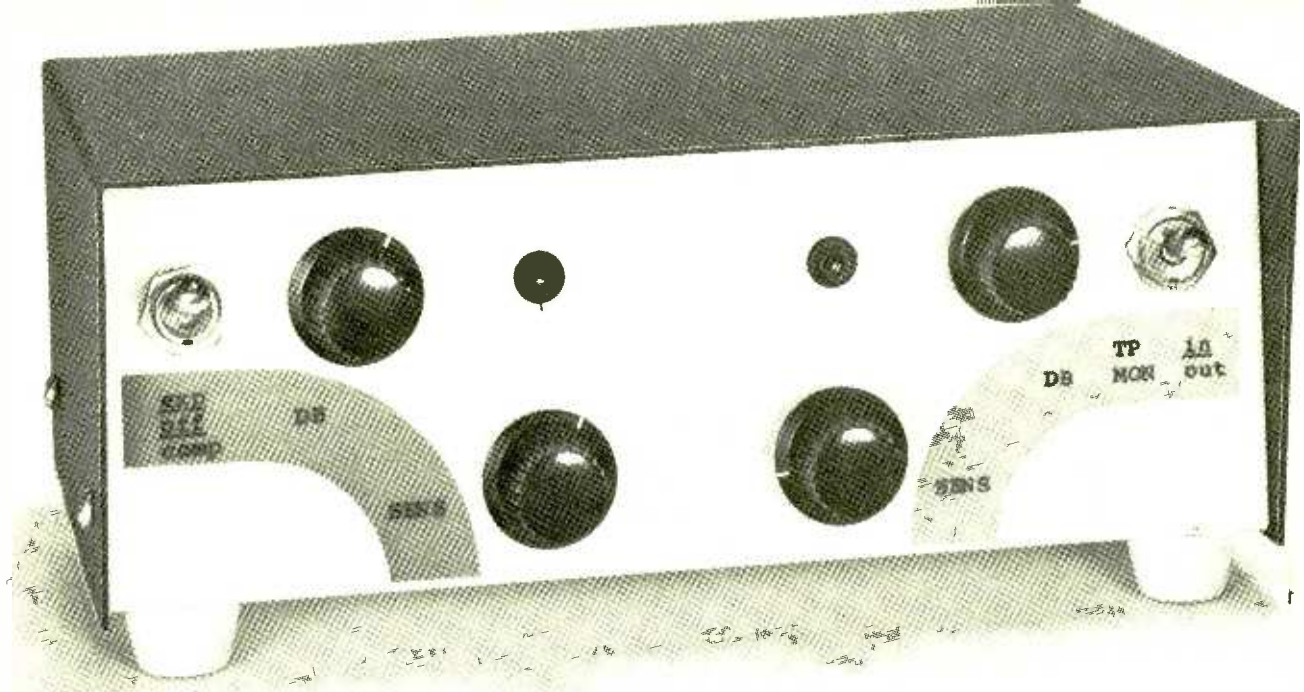

# LOW-COST COMPANDER ENHANCES HI-FI RECORDINGS

BY CRAIG ANDERTON

*Simple accessory expands or compresses  
playback's dynamic range.*

Since the dynamic range of live music is usually greater than the range that discs and tapes can handle, it is standard practice to introduce a certain amount of level compression when a recording is made. Unfortun-

ately, this compression limits many crescendoes and percussive transients that add to the enjoyment of the music. Thus, it is desirable, on playback, to expand the volume to replace the missing peaks. On the other hand,

it is sometimes necessary to eliminate loud level changes when using music as a background.

To provide either expansion or compression of the sound, the simple compander described here can be

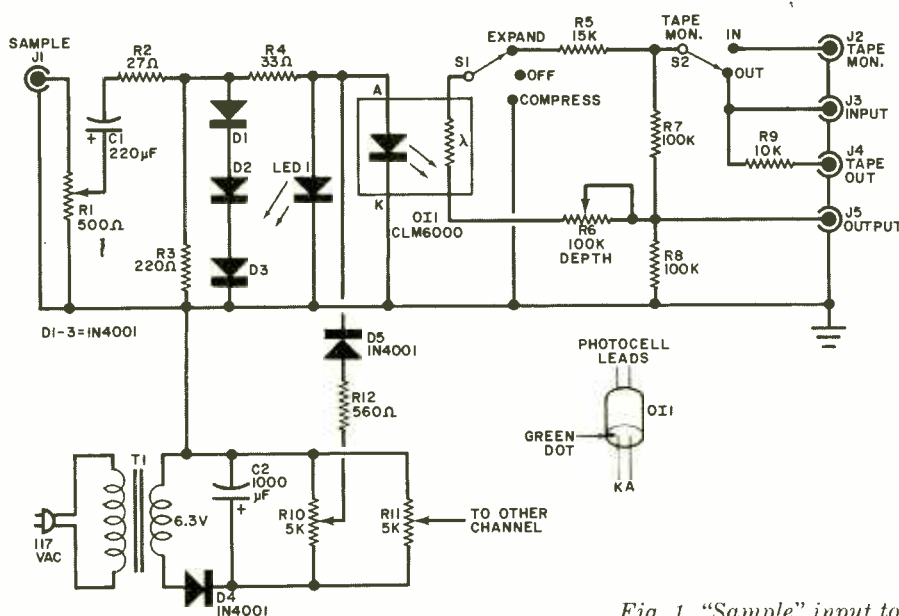

Fig. 1. "Sample" input to compander is same as input to the speaker.

## PARTS LIST

- C1—220- $\mu$ F, 50-volt, electrolytic capacitor\*
  - C2—1000- $\mu$ F, 15-volt, electrolytic capacitor
  - D1 to D5—1N4001 diode (or similar)\*
  - J1 to J5—Phono jack\*
  - LED1—MV50 light emitting diode (or similar)\*
  - O1—Optical isolator (Clairex CLM6000 or similar)\*
  - R1—500-ohm linear taper potentiometer\*
  - R2—27-ohm, 5%, 1/4-watt resistor\*
  - R3—220-ohm, 5%, 1/4-watt resistor\*
  - R4—33-ohm, 5%, 1/4-watt resistor\*
  - R5—15,000-ohm, 5%, 1/4-watt resistor\*
  - R6—100,000-ohm linear taper potentiometer\*
  - R7, R8—100,000-ohm, 5%, 1/4-watt resistor\*
  - R9—10,000-ohm, 5%, 1/4-watt resistor\*
  - R10, R11—5000-ohm linear taper potentiometer
  - R12—560-ohm, 5%, 1/4-watt resistor\*
  - S1—Spdt (center off) switch\*
  - S2—Spdt switch\*
  - T1—6.3-volt filament transformer
  - Misc.—Perforated board, mounting clips, suitable chassis, lettering, line cord, knobs, mounting hardware, etc.
- \*Double quantity for two channels.



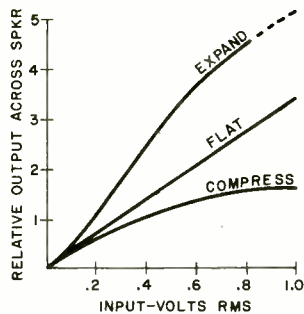

Fig. 2. Graph shows how compander expands or compresses the relative output across speaker.

hooked up between your preamp and power amp or through the tape monitoring circuit. (A compander is not to be confused with devices such as tone controls and equalizers, which alter the frequency response of a system.)

**Circuit Operation.** The heart of the compander circuit (Fig. 1) is an optoisolator (O1), which contains a light emitting diode and a low-distortion photocell in a light-tight plastic enclosure. This unit has much faster response time than devices using an incandescent lamp (often used in compressors). It also introduces less distortion and has the advantage of providing a slight "slow release" action to enhance the expansion effect.

The audio signal at the speaker terminals of the amplifier is applied to connector J1. The level is controlled and reduced by R1, R2, and R3, with diodes D1 to D3 acting as voltage limiters to protect the LED's. The signal level is monitored by LED1. The brightness of the LED in O1 varies with the signal causing the resistance of the photocell to vary.

The power supply provides a small dc voltage (adjusted by R10) to keep the two LED's within their conduction range. This prevents a sudden snap in the volume when a signal is applied.

With S1 in the OFF position and S2 on OUT, the input signal at J3 is applied to R7 and R8 and the output at J5 is half of the input. This insertion loss is required to create the "headroom" needed for expansion.

When S1 is in the EXPAND position, the photocell in O1 is connected across R7 to vary the resistance of the upper half of the voltage divider. This changes the output at J5. Potentiometer R6 acts as a "depth" control to determine how much the variations in the photocell resistance affect the voltage divider.

As the sampled signal increases, resistance of the photocell decreases, increasing the output at J5. This provides the desired expansion.

When S1 is in the COMPRESS position, the photocell is connected across R8 so that, as the sampled signal increases, the output at J5 decreases.

The curves in Fig. 2 are typical of the expansion compression effects.

**Construction.** The complete circuit, with the exception of transformer T1, can be assembled on perforated board. The transformer should be located as far as possible from the signal leads to avoid pickup.

The circuit shown in Fig. 1 is for one channel, except that the power supply can handle two channels for stereo. Mount the various phono jacks and the two calibrate controls (R10 and R11) on the rear apron (suitably identified) and the switches and depth potentiometers on the front panel. The two monitoring LED's can also be mounted in rubber grommets on the front panel. An on/off switch can be used in the primary of T1 or the compander power supply can be plugged into a switched receptacle on the preamplifier.

**System Hookup.** The compander will work with any amplifier that delivers two watts or more of output. If you have a separate preamplifier/power-amplifier setup, use the hookup shown in Fig. 3A. Use shielded audio cables to interconnect the three devices. Be sure the "hot" side of the amplifier output is fed back to the compander.

If you have an integrated unit, use the hookup shown in Fig. 3B. Connect a shielded audio cable from the tape-output jack of the amplifier to J5 of the compander and another shielded cable from J2 on the compander to

the tape-monitor jack on the amplifier. By switching the amplifier's tape monitor to "in," the compander will be put into the circuit.

**Checkout.** With the system properly connected (be sure not to confuse the channels) and operating, adjust each channel's calibrate control (R10 and R11) until the front-panel monitor is just illuminated. Proper adjustment here provides the best linearity and channel balance.

Working with one channel at a time, place S1 in the EXPAND position, the sensitivity control (R1) at minimum, and the depth control (R6) at maximum. Turn up the volume on your system to the most comfortable listening level. Then advance the sensitivity control until LED1 starts to flicker. Avoid bright peaks on the LED. The music should sound more accented, with a greater dynamic range. Operate the depth control to obtain the desired amount of expansion. To be sure everything is working, turn off the compander and note how much flatter the music sounds.

To check compression, place S1 on COMPRESS and the sensitivity and depth controls to maximum. Turn up the volume. You should note that the audio output does not rise above the preset level. Adjust both controls to obtain the best output.

At some low listening levels, there may not be quite enough signal to drive the compander properly. This produces a "breathing" effect which can be remedied by turning up the listening level or turning down the depth control. This effect may also occur if the calibration controls are not set high enough.

There is no such thing as the optimum amount of expansion. Some recordings require less than others. However, most will benefit from the extended dynamic range. ♦

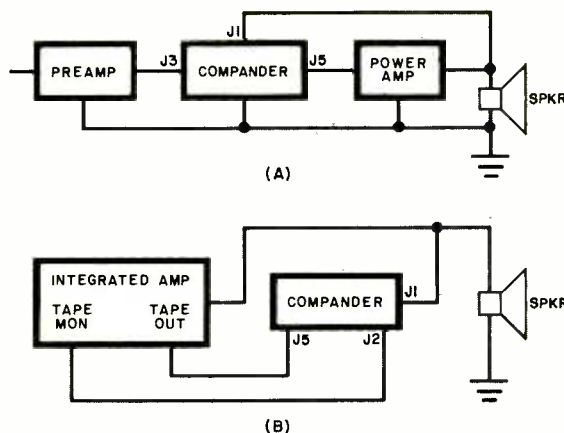
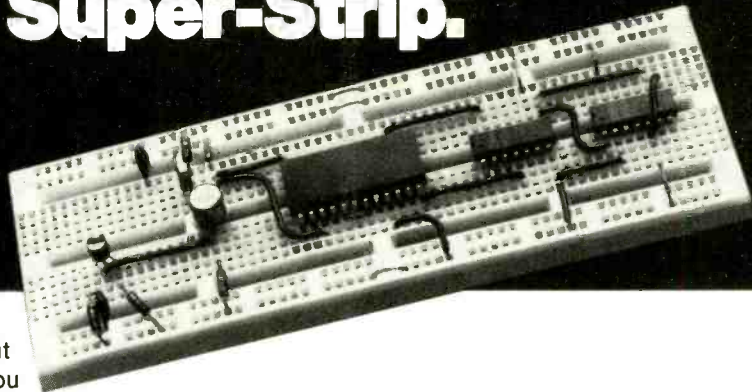

Fig. 3. If you have separate preamp and power amplifier, use hookup at (A). For integrated amplifier, use (B). Both are for one channel only.

# Circuits happen Faster and Easier with Super-Strip.™

As little as  
**\$17**



Now, whenever you'd like to give a circuit a try, you can build it up nearly as fast as you can dream it up with Super-Strips™, the faster, easier and less expensive solderless breadboards from A P Products. When you build your circuit on a Super-Strip, everything stays as good as new. Once you're through, you can use everything again and again. Instantly. Put a Super-Strip to work for you. Eight distribution lines handle signal and power, and 128 five-tie-point terminals can handle 9 ICs and then some. It's a whole lot easier than printing a circuit and a whole lot handier than haywire.

Part Number	Model Number	Terminal Type	Price Each
923252	SS-2	nickel-silver	\$17.00
923748	SS-1	gold-plated	\$18.90

Order from your A P distributor today. Our distributor list is growing daily. For the name of the distributor nearest you call Toll-Free 800-321-9668.



Send for our complete A P catalog, the Faster and Easier Book.

## A P PRODUCTS INCORPORATED

Box 110 Painesville, OH 44077 (216) 354-2101 TWX: 810-425-2250

# You've seen the rest... now try the best.

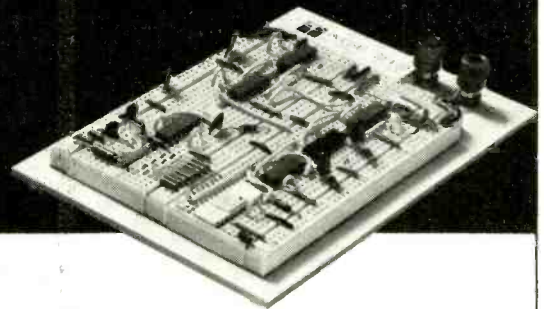
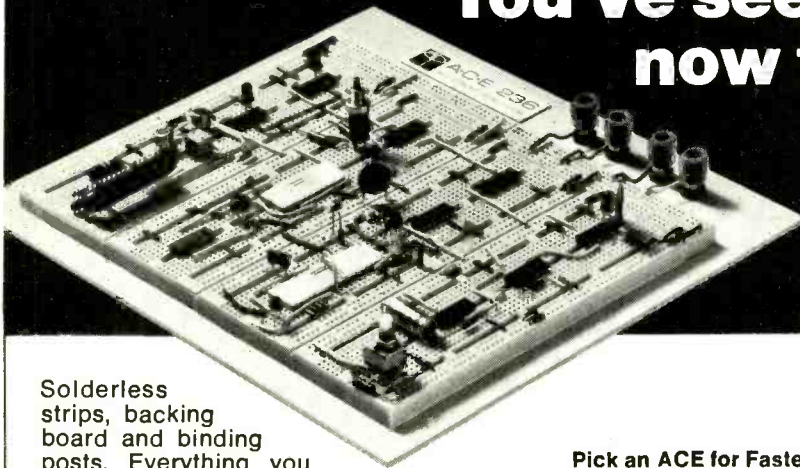

Solderless strips, backing board and binding posts. Everything you need to build and test your own circuit. Used to be you'd get a circuit idea, lay out a pc board, print it, solder everything together, trouble-shoot, change your layout, try a new board, and spend absolutely too much time breadboarding. Now A P ACE All Circuit Evaluators let you breadboard in a fraction of the time. Make your changes immediately. Keep full leads on your components. Avoid the heat damage possible with repeated soldering and de-soldering. A P made the first modern solderless breadboard, and we still make them best.

Pick an ACE for Faster and Easier solderless circuit building and testing.

Send for our complete A P catalog, The Faster and Easier Book.

Part No.	ACE Model No.	Tie Points	DIP Capacity	No. Buses.	No. Posts	Board Size (inches)	Price Each
923333	200-K (kit)	728	8 (16's)	2	2	4-9/16x5-9/16	\$18.95
923332	208 (assem.)	872	8 (16's)	8	2	4-9/16x5-9/16	28.95
923334	201-K (kit)	1032	12 (14's)	2	2	4-9/16x7	24.95
923331	212 (assem.)	1224	12 (14's)	8	2	4-9/16x7	34.95
923326	218 (assem.)	1760	18 (14's)	10	2	6-1/2x7-1/8	46.95
923325	227 (assem.)	2712	27 (14's)	28	4	8x9-1/4	59.95
923324	236 (assem.)	3648	36 (14's)	36	4	10-1/4x9-1/4	79.95

Order from your A P distributor today. Our distributor list is growing daily. For the name of the distributor nearest you call Toll-Free 800-321-9668.

## A P PRODUCTS INCORPORATED

Box 110 • 72 Corwin Drive  
Painesville, Ohio 44077  
216/354-2101 TWX: 810-425-2250



# Great Jumpers are here!

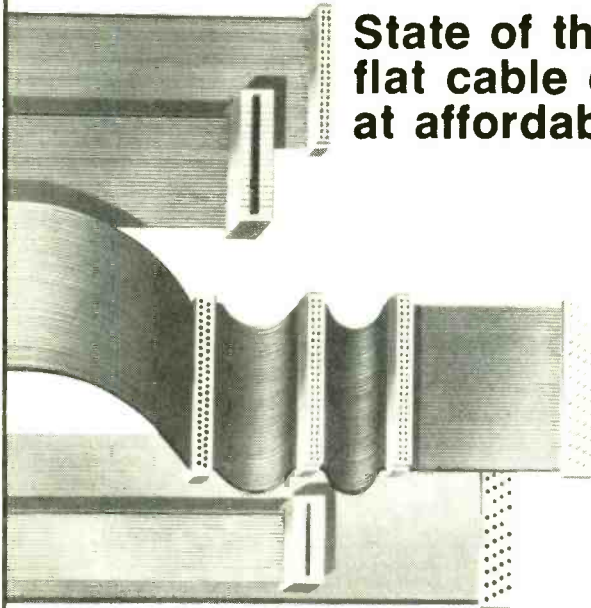

**State of the art  
flat cable connector assemblies . . .  
at affordable prices.**

Great Jumpers come to you fully pre-assembled and fully pre-tested. Cable strain reliefs are integral to the molded-on connectors. And we've designed in complete line-by-line probeability with probe access ports behind each contact.

Our connectors are industry standard; two parallel rows of contacts, spaced every .1".

Great Jumpers come in five popular cable widths: 20, 26, 34, 40 and 50 lines wide, and in lengths ranging from 6" to 36".

Available now at the distributor near you who carries the A P Products Faster and Easier Line.

Our distributor list is growing daily. For the name of the distributor nearest you call Toll-Free 800-321-9668.

Send for our complete AP catalog, the Faster and Easier Book.

**Faster and easier is what we're all about.**



**AP PRODUCTS INCORPORATED**

Box 110 • 72 Corwin Drive Painesville, OH 44077 (216) 354-2101 TWX: 810-425-2250

## Connect with a little help from A.P.

**Intra-Connector**

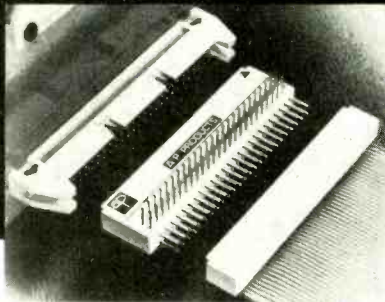

**Intra-Switch**

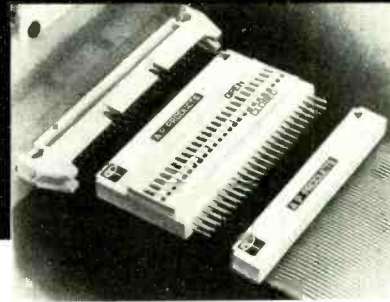

**Intra-Connector and Intra-Switch do for flat cable systems what our IC Test Clips do for DIPs, which can do a lot for you.**

Intra-Connector mates in-line with standard double row socket connectors. It has one set of female contacts, but two sets of male, at right angles. So it provides instant line-by-line probeability, and, allows for attachment of test probes, components or an additional connector.

Intra-Switch plugs right in line, too. But small, dependable slide switches are built

right in to switch each line, independently. So it's great for diagnostic and quality testing, terrific for programming or selective line inhibiting.

Intra-Connector and Intra-Switch are available in 20, 26, 34, 40 and 50 contact versions at the dealer or distributor in your area who stocks our Faster and Easier Line. You can locate him by calling our toll-free number, 800-321-9668.



**Faster and easier  
is what we're all about.**



**AP PRODUCTS INCORPORATED**

Box 110 • 72 Corwin Dr., Painesville, OH 44077 • (216) 354-2101 TWX: 810-425-2250

**U**NNECESSARY muscular tension is known to be one of the contributing factors to psychosomatic illness. Unfortunately, much of this muscular tension is subconscious so many people can't relax because they aren't aware of the tension. Consequently, many methods have been devised to provide recognition of tension and encourage relaxation—including yoga and "autogenic training" (biofeedback techniques).

To detect muscular tension scientifically it is only necessary to measure the minute electrical signals generated by a muscle when it is working. This is done by an electromyograph (EMG). The EMG has electrodes which are placed in intimate contact with the skin over a given muscle. When the muscle is under tension, the EMG provides either a visual (meter) or audible indication of the muscle tension. The person to whom the electrodes are attached then becomes part of the feedback loop through his eyes or ears and can try to reduce the tension by mental or physical means. With this electronic aid, a person can learn to eliminate or greatly reduce the tension, thereby bringing about changes in general well-being.

Relaxation is not achieved instantaneously, and many training sessions may be required in difficult cases. Since emotions play a large role in the production of tension, unexpected feelings may be experienced when one becomes familiar with "letting go." The simple EMG feedback monitor described here can be used to practice muscle relaxation and also to explore the building up of muscles.

A block diagram of the monitor is shown in Fig. 1. The minute (microvolts) muscle signals detected by the skin electrodes are amplified and then applied to a rectifier/integrator stage. The pulses are averaged and either displayed on a meter or used to drive a voltage-controlled oscillator that generates a series of clicks for the audible signal. The amount of muscular tension—and the magnitude of the

#### EDITOR'S NOTE

This muscle monitor is intended for experimentation and entertainment only. It is not to be used as a substitute for professional clinical therapy. Persons with heart disease, high blood pressure, or any other tension-related illness should consult a physician. The monitor is *not* to be considered a home remedy for any illness.

## BUILD A

# MUSCLE FEEDBACK MONITOR

*New biofeedback  
technique helps  
to reduce tensions.*

BY MITCHELL WAITE

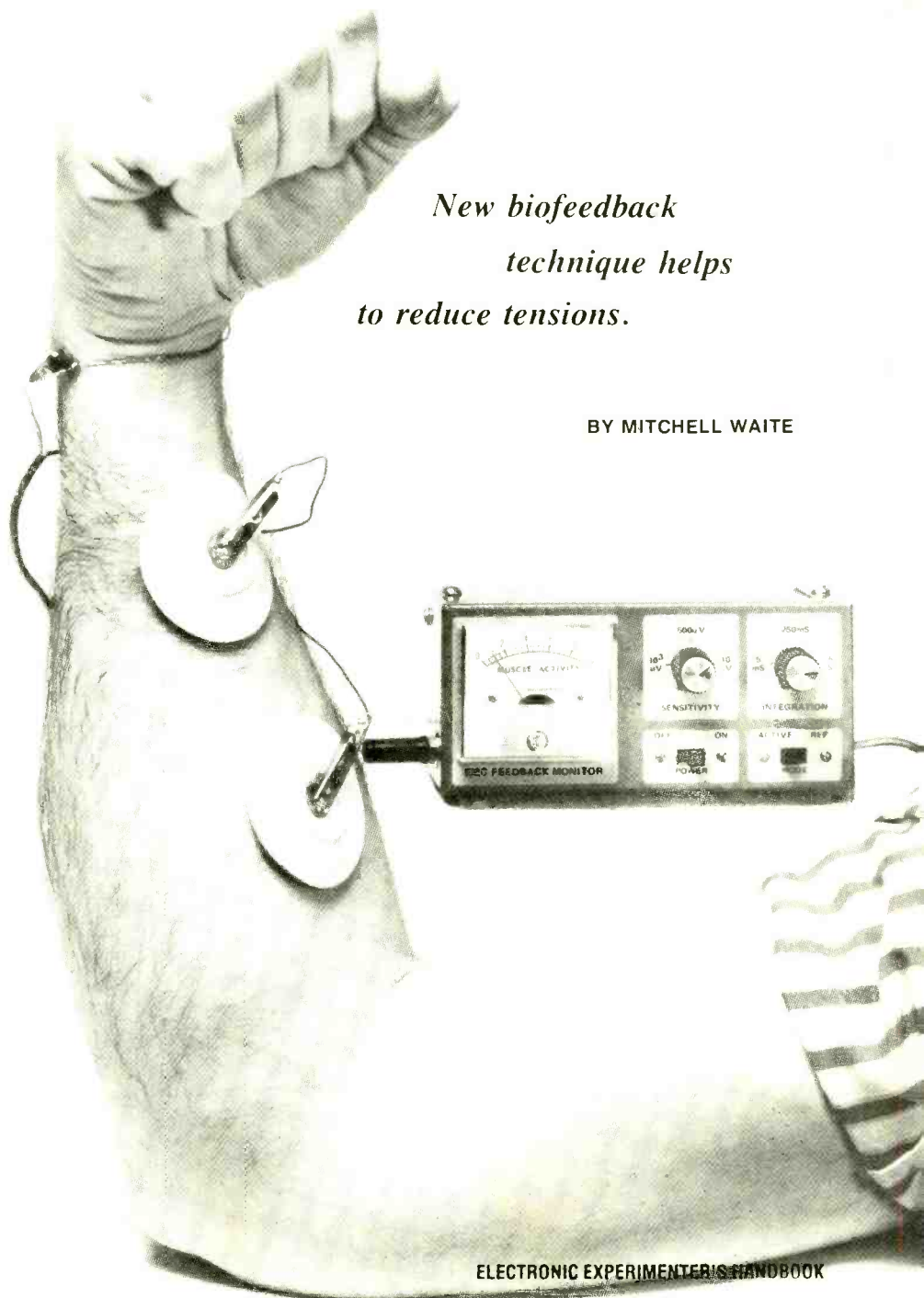

voltage picked up by the electrodes—varies the reading on the meter and the frequency of the clicking sound.

**How It Works.** In a device of this type, the differential input preamplifier is the most important stage (*Q1*, *Q2*, and *IC1* in Fig. 2). This is because common-mode signals such as stray 60-Hz fields and associated line noises, put a limit on the signal resolution. The circuit's common-mode input impedance is compared to the source unbalance to determine the maximum common-mode rejection ratio.

In the circuit, op amp *IC1* is used as a bootstrap element. The common-mode signal on the collector of current source *Q3* is fed back to the input through *R3*, *R4*, and *R5* so that the common-mode signal actually "sees" an impedance much higher than the values of these resistors. With this circuit, the balance between *C1-R1* and *C2-R2* and the impedance of the electrode determines the overall common-mode rejection. Making *C1* and *C2* larger in value improves common-mode rejection but also increases the recovery time due to transients at the electrodes. Input noise in the circuit is minimized by using low-noise transistors and designing the collector currents for low noise. R-f interference is drained off by capacitors *C3* and *C4*.

The output of the preamplifier is applied to *IC2*, a high-gain, noninverting amplifier. Associated with the amplifier are a low-pass filter (-3 dB at 1 kHz) made up of *C6* and *R11* and a high-pass filter (-3 dB at 200 Hz) made up of *C7* and *R12*. A second high-pass filter (*Q4*) further reduces low-frequency components. Sensitivity is set by *R25* and the signal is applied to a gain-of-30 noninverting amplifier (*IC3*), which also acts as a rectifier, integrator, and meter amplifier. Rectifier *D1* is located in the feedback circuit to reduce the effects of the diode voltage drop to a few millivolts. Transistor *Q5* acts as a buffer between the integrator and the meter.

Overall muscle activity can be averaged between 5 ms and 0.5 s, depending on the setting of *R26*. The sensitivity control, *R25*, is calibrated when integration is set at maximum.

The output frequency of the voltage-controlled oscillator (*IC4*) is a function of the voltage level applied to its input through *R22*. The timer is biased so that, at a certain low-voltage thresh-

## MUSCLE BIOFEEDBACK APPLICATIONS

**Feedback Technique for Deep Muscle Relaxation.** Experiments have shown that zero-firing of single motor units with EMG BFT can be achieved in less than twenty minutes. Most subjects report changes in body image. Further, work reveals that people can subjectively turn on and off, selected single-muscle motor units, even delicately controlling their firing patterns.

**Paralyzed Muscles Retrained at Home.** People recovering from cardiovascular accidents are often faced with the retraining of paralyzed limbs—a long and tedious job. Experiments are revealing now that much of the work load can be taken off the patient and also speeded up if biofeedback techniques are applied. An EMG monitor can sense minute muscle activity and inform the patient of the activities instantly.

**"Talking" Muscles Help Scientists Design for Maximum Efficiency.** A group of researchers at Eastman Kodak Co., known as the Human Factors Group, is looking into the activity of muscles in industry. Using the results of EMG data and performance tasks, they are able to design steps for a job to provide the least muscle discomfort, while obtaining maximum productivity of body movements.

**EMG Signals Give Hams a Third Hand.** Many who are physically handicapped are interested in amateur radio as a hobby. In a series of unique experiments, doctors have used the still-good EMG signals going to an amputee's missing limb to control a Morse code relay. Patients have, after brief training, learned to send up to 15 words per minute! By using a rectified EMG signal, 360-degree servo control for an antenna and tuning coils was achieved.

**Learning to Control Tension Headaches.** Experiments have shown that, by monitoring the "frontalis" or forehead muscle and using feedback, people can learn to reduce the occurrence of tension headaches. When presented this information, in a comfortable manner, patients have learned to abort the headaches without the biofeedback equipment.

**Lowering Anxiety.** EMG biofeedback has perhaps its greatest potential as an aid to anxiety reduction. By helping psychologists show their patients how to initiate self-induced calm and real relaxation, EMG monitors would be useful. Though still in its infancy, this application has vast potential and is the area of most interest for EMG at this time.

old, the oscillator automatically shuts off. The threshold is determined by the gain of the circuit and the value of *R24*. The turn-on threshold is approximately 2.5 microvolts at the skin electrodes with the sensitivity control set to maximum. Reducing the sensitivity raises the threshold point. The threshold was selected to make changes in muscle tension more ap-

parent. The frequency range of the vco is approximately 5 to 30 pps.

Power for the circuit is provided by two 9-volt batteries. The power for the input stage is decoupled by *R20* and *C12* for the positive side and *R21* and *C13* for the negative.

**Construction.** Due to the high gain and complexity of the circuit, a pc board should be used. An actual-size foil pattern and component placement are shown in Fig. 3. When installing the components, be sure they are properly oriented with regard to terminals and polarities. Don't forget the single jumper on the component side. Note that some pads on the foil pattern have numbers corresponding to those on the schematic.

The pc board and the two batteries (preferably alkaline) are installed in a suitable metal enclosure. Metal is used to keep 60-Hz interference to a minimum. Mount the components on the front panel as shown in the photograph. The audio output jack is mounted on one side of the enclosure.

The SENSITIVITY control is marked for 10<sup>3</sup> μV in the full counterclockwise position, 500 μV at the center and 10 μV at the other end. Mark the

Fig. 1. The EMG feedback loop.

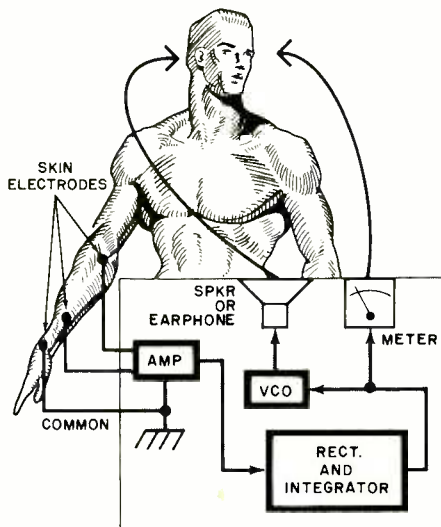

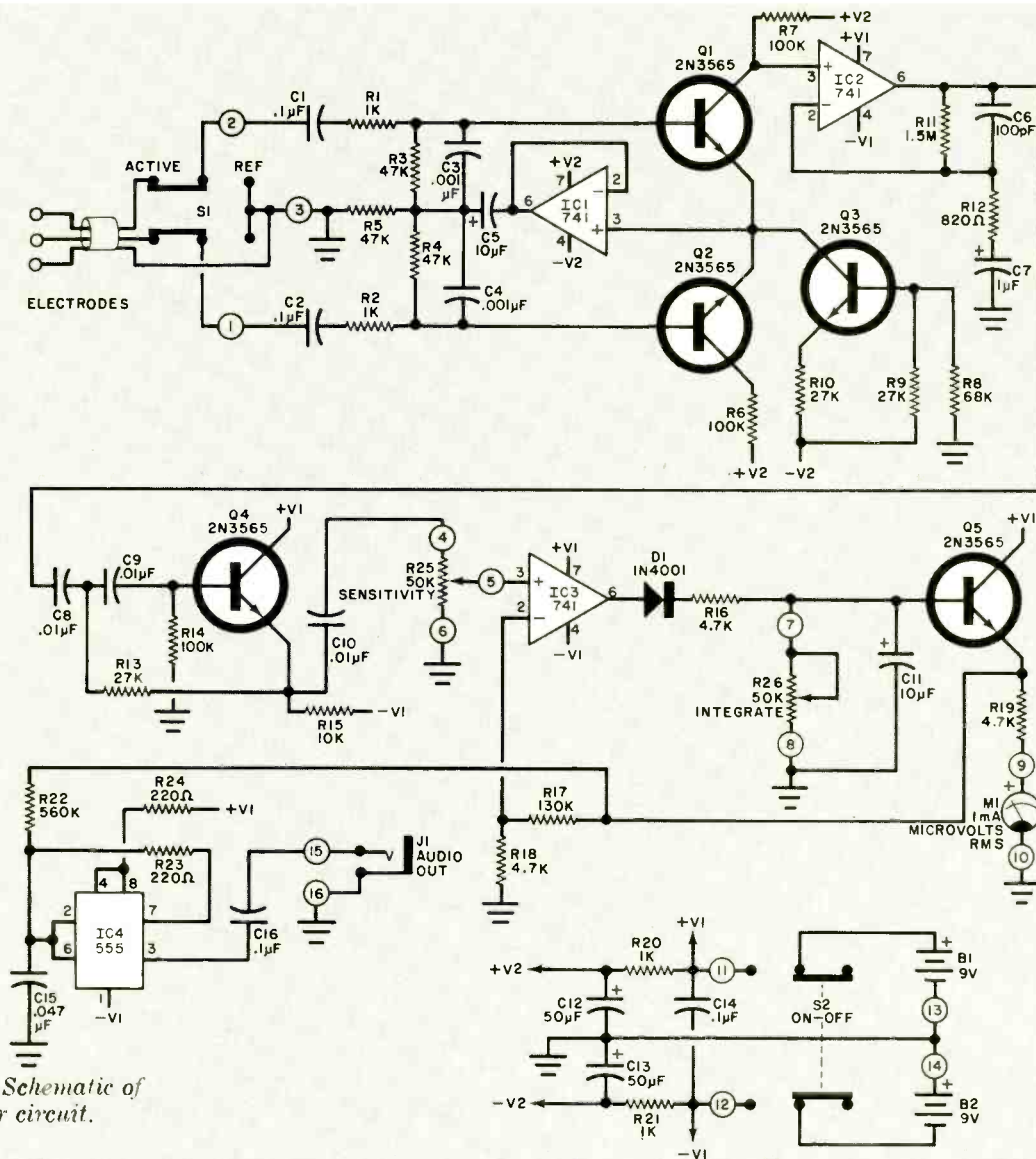

Fig. 2. Schematic of monitor circuit.

### PARTS LIST

- B1, B2—9-volt battery
  - C1, C2—0.1- $\mu$ F, 10% Mylar capacitor
  - C3, C4—0.001- $\mu$ F, 10% Mylar capacitor
  - C5, C11—10- $\mu$ F, 10-V electrolytic capacitor
  - C6—100-pF, 10% silver-mica capacitor
  - C7—1- $\mu$ F, 10-V electrolytic capacitor
  - C8 to C10—0.01- $\mu$ F, 10% Mylar capacitor
  - C12, C13—50- $\mu$ F, 10-V electrolytic capacitor
  - C14, C16—0.1- $\mu$ F, 10% Mylar capacitor
  - C15—.047  $\mu$ F 10% Mylar capacitor
  - D1—1N4001 diode
  - IC1 to IC3—741 op amp
  - IC4—555 timer
  - J1—Miniature earphone jack
  - M1—1-mA meter (Radio Shack 22-037 or similar)
  - Q1 to Q5—2N3565 transistor
- Following resistors are  $\frac{1}{4}$ -watt, 5%:
- R1, R2, R20, R21—1000 ohms
  - R3 to R5—47,000 ohms
  - R6, R7, R14—100,000 ohms
  - R8—68,000 ohms

- R9, R10, R13—27,000 ohms
  - R11—1.5 megohms
  - R12—820 ohms
  - R15—10,000 ohms
  - R16, R18, R19—4700 ohms
  - R17—130,000 ohms
  - R22—560,000 ohms
  - R23, R24—220 ohms
  - R25, R26—50,000-ohm linear potentiometer
- S1, S2—Dpdt subminiature switch
- Misc.—Miniature crystal or magnetic earphone and plug; set of electrodes ( $\frac{1}{2}$ " stainless steel discs and electrode paste) or disposable Ag/Ag-C1 types; enclosure (LMB-778 or similar); knobs (2); two-conductor shielded cable (5 ft); miniature alligator clips (3); rubber grommet; mounting hardware. Disposable Ag/Ag-C1 electrodes are available from medical supply houses. Permanent Ag/Ag-C1 electrodes are preferred for ease of use. Small plastic containers of electrode cream are also available from medical supply houses.

Note—The following are available from EDC, P.O. Box 9161, Berkeley, CA 94709; complete kit of parts including two disposable Ag/Ag-C1 electrodes, stainless steel reference electrode, drilled and solder-plated pc board, drilled and painted enclosure, and 1-oz container of electrode gel (kit PE-22) at \$39.50; separate drilled and solder-plated pc board (PE-23) at \$5.95; set of two disposable Ag/Ag-C1 electrodes (PE-25) at \$3.98; pair of permanent Ag/Ag-C1 electrodes (PE-26) at \$19.95; 1-oz container of electrode gel (PE-9) at \$0.75; 4-oz container of electrode gel (PE-9X) at \$2.50. Orders for complete kits shipped postpaid and insured. Orders for components and accessories shipped postpaid, insurance extra. Add \$1.00 for handling on orders less than \$5.00. California residents, please add 6% sales tax (6 $\frac{1}{2}$ % for BART counties).

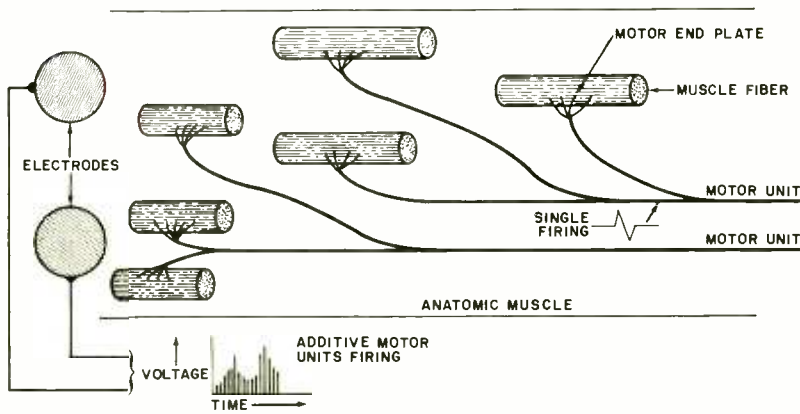

### THE SOURCE OF MUSCLE SIGNALS

The signals picked up by the muscle monitor originate in large motor nerves, each of which supplies pulses to any of 25 to 2000 motor end plates. (Only three end plates are shown in the diagram for simplicity.) Each set of end plates makes up a "motor unit." The motor units are not clumped together, but are interlaced to give the muscle its smoothness in movement. The electrical signal associated with the tensing of a muscle is made up of thousands of randomly additive microvolt pulses. Each pulse is associated with a motor

unit, and each motor unit may drive many hundreds of muscle cells.

For medium tension (with Ag/Ag-Cl skin electrodes), the EMG energy is at a frequency between 200 and 2000 Hz and an amplitude between 500  $\mu$ V and 1 mV. It is noise-like in appearance. However, at low tension levels, individual motor units may be differentiated with pulse rates of 25 to 100 pps. Amplitudes are between 5 and 25  $\mu$ V, depending on the physical distance between the motor units and the skin electrode.

INTEGRATION control 5 ms on full CCW, 250 ms at the center, and 0.5 s for full CW.

**Circuit Checkout and Use.** With fresh batteries installed, connect both "live" inputs across a resistance of 1000 to 5000 ohms and insert an ear-phone in *J1*. With the MODE switch ON REF, and SENSITIVITY and INTEGRATION controls maximum clockwise, turn on the monitor. The meter indication should be between 1/5 and 1/4 of full scale, indicating the maximum noise being generated in the circuit. There may be a slight delay (about half a second) before the meter deflects, as the input stage stabilizes.

Put the MODE switch on ACTIVE and note that the meter indication rises as the added noise of the resistor comes into play. Note also that the vco rate increases (through the earphone).

When you are sure that the circuit is operating properly, attach the two active leads to an area over a forearm muscle and attach the shield lead (with its electrode) to an area (such as the wrist) where there is little muscle activity. The two active leads should be attached to high-quality, low-noise electrodes such as a disposable or permanent silver/silver-chloride type. The shield of the electrode cable is the reference lead and should be connected to a low-cost electrode (such as stainless steel). The electrodes are held in position with tape or some other type of adhesive.

With the MODE switch on ACTIVE, adjust the INTEGRATION control to 0.5 s and set the SENSITIVITY control to its minimum. Slowly increase the latter while flexing the forearm muscles. Observe the change in indication on the meter and in the frequency of the audible signal. Make a note of the SENSITIVITY setting when the arm is relaxed. Try the approach once more, this time trying for a lower relaxed reading by changing your thoughts and mental attitude.

Move the SENSITIVITY control up slightly and try again to relax the forearm to reduce the indications to zero. Repeat this operation with the SENSITIVITY increased again. A regular daily routine works best, practicing between 15 and 30 minutes a day on muscle areas that give you a particular problem—such as the forehead if you have tension headaches. Keep a record of sensitivity readings, and in a period of a week you should see some sign of improvement.

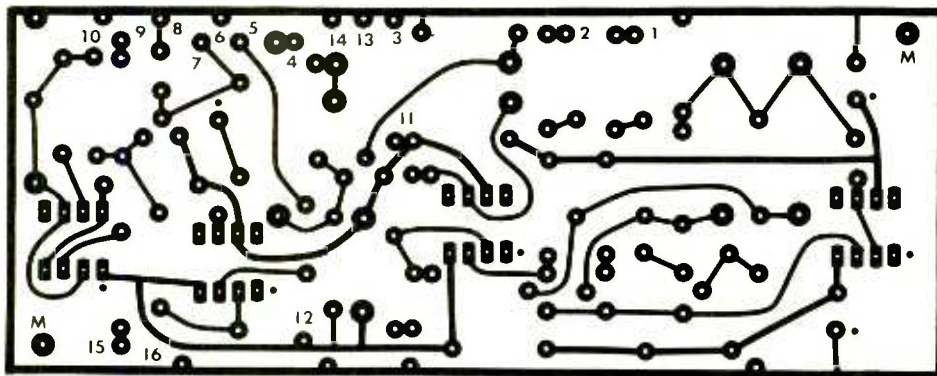
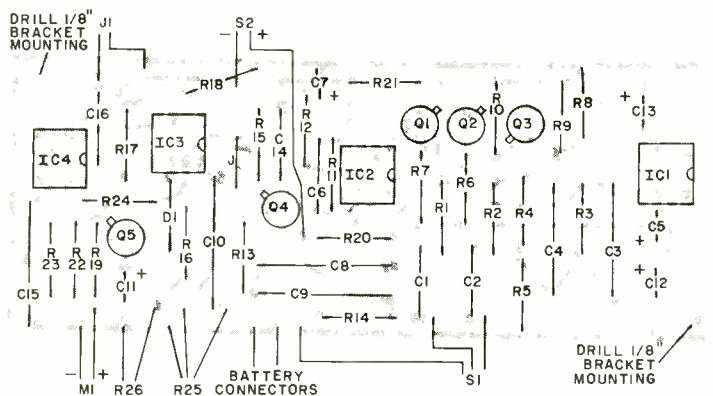
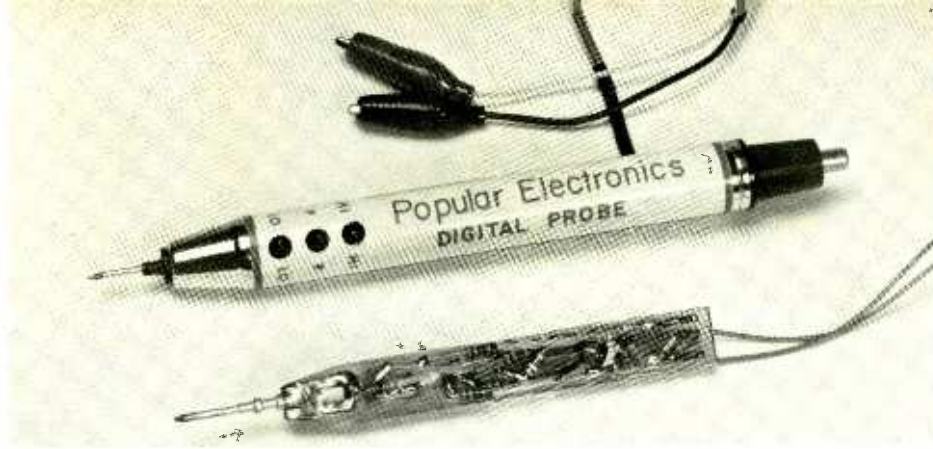

Fig. 3. Etching and drilling guide (above) and component layout.





# IC DIGITAL LOGIC MEMORY PROBE

*Indicates logic state of circuit and detects pulses as short as 50 ns.*

BY RICHARD P. MAY

ONE of the more vexing problems facing today's experimenter is finding a way to check the 5-volt logic devices that dominate the hobby construction scene. Lacking a high-speed triggered-sweep oscilloscope, the experimenter is left defenseless in coping with the frequent 50-ns pulses that are more than long enough to trigger IC logic devices. To cope with the problem without a scope, however, you can build the digital logic memory probe described here. It is designed to indicate the logic state of a circuit, providing detection capabilities for pulse durations as short as 50 ns.

The circuitry of the probe is housed in a penlight tube and derives its power from the 5-volt line and signal ground of the circuit under test. The indicator system consists of three light-emitting diodes (LED's) mounted in-line at the end of the probe tube. The top LED lights up for a logic 1, while the bottom LED illuminates for a logic 0 (2.4 or more volts and less than 0.8 volts, respectively). The center LED comes on to indicate a positive- or negative-going transition as short in duration as 50 ns and remains on for 200 ms without regard to the time duration of the pulse being observed. This stretching feature provides ample time to observe a short-duration pulse that would otherwise not be seen on the 1 and 0 LED readouts.

To expand the stretching feature, a switch on the probe can be used to activate a memory mode that causes the stretch LED to remain on permanently after a positive or negative pulse occurs. The memory mode can aid in establishing the presence of

unwanted pulses (such as noise). To reset the memory, the switch is simply returned to the stretch mode.

The memory mode can also be used to detect a power failure that might cause a sequence scrambling in the system under test. To accomplish this, the power input leads of the probe are connected to the 5-volt supply line and the switch is set to the memory mode. If the power should fail and self-restore, it will leave the stretch LED illuminated, indicating that a power interruption has occurred.

**Construction.** To keep the project as compact as possible so that its simple circuit (see Fig. 1) will fit into the penlight body, printed circuit construction is highly recommended. An actual-size etching and drilling guide is shown in Fig. 2. Also shown are two component placement guides, since the components mount on both sides of the board.

Before you begin assembly, remove

from IC1 (7404) pins 5, 6, 8, 9, 12, and 13 and from IC2 (9601) pins 5, 8, 9, 10, and 12. This will permit maximum utilization of the available board space. Then mount and solder in place all components as shown.

Mount the probe tip in the board's end slot as follows: First, place the tip in the slot and secure it with a couple of turns of bare solid hookup wire, passing the wire through the four holes provided. Heat sink the cathode end of D1. Then liberally apply solder along both sides of the tip where it joins the foil pattern.

Prepare the ends of two 5-in. lengths of stranded hookup wire. Solder these wires to the holes shown. Then prepare one end of the coaxial cable and solder the inner conductor to the "+" hole on the board and the shield to the "-" hole.

Carefully spot on the body of the penlight flashlight the three holes for the LED's, using the board assembly to guide you. The exit hole for the coa-

## HOW IT WORKS

The memory probe (Fig. 1) is powered by the circuit under test. Diode D2 protects the probe should the wrong hookup be made to the power line. The combination of D1 and R1 provides over-voltage protection. Diode D1 buffers IC1 from excessively high inputs and insures a high input impedance (better than 75,000 ohms with a high input).

Transistor Q1 provides a high input impedance and serves as a buffer for the input of A1 in IC1. When the probe tip is not terminated, pin 11 of IC1 is low and pin 1 goes high. Inverting through A3 and double inverting through A1 and A2, LED1 and LED2 extinguish. With a low input (0.8 volt or less), pin 1 of A1 goes low. Then by double inversion through A1 and A2, LED2 turns on. All the while, Q1 is cut off and LED1 remains extin-

guished. A high input causes LED2 to turn off and sends Q1 into conduction, resulting in LED1 turning on.

The on time of IC2 (a triggerable one-shot multivibrator) is determined by the time constant of C1 and R4, which is 200 ms with the component values specified. The IC is triggered by a negative-going transition at pin 1 or pin 2. Any level change at the probe tip will cause this condition, triggering IC2 and turning on LED3 for 200 ms.

To prevent IC2 from timing out after being triggered, memory switch S1 must be closed. When pin 6 of IC2 goes low at the moment of triggering, the signal is applied to the junction of C1 and R4. This prevents C1 from charging, and IC2 remains in the triggered state. Opening S1 permits normal timing to resume.



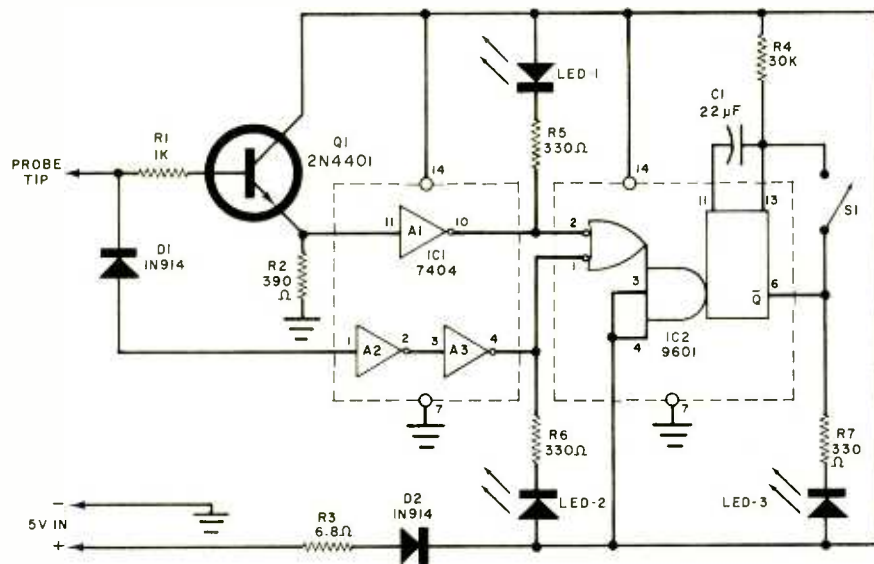

### PARTS LIST

- C1—22- $\mu$ F, 10-volt tantalum capacitor
- D1, D2—1N914 diode
- IC1—7404 integrated circuit
- IC2—9601 integrated circuit
- LED1-LED3—Light-emitting diode (Monsanto MV-5022)
- Q1—2N4401 transistor
- R1—1000-ohm, 1/4-watt resistor
- R2—390-ohm, 1/4-watt resistor
- R3—6.8-ohm, 1/4-watt resistor
- R4—30,000-ohm, 1/4-watt resistor
- R5-R7—330-ohm, 1/4-watt resistor
- S1—Part of penlight flashlight
- Misc.—Printed circuit board, probe tip, penlight flashlight body, insulating spaghetti, 4"-long  $\times$  1/2"-diameter heat-shrinkable tubing, small-diameter heat-shrinkable tubing, 3' length small-diameter coaxial cable, one black-booted miniature alligator clip, one red-booted miniature alligator clip, stranded and solid hookup wire, solder, etc.

Fig. 1. Circuit diagram of digital probe, which uses two ICs.

xial cable does not require critical location so long as it is clear of the board and does not interfere with switch operation. Label the LED holes LO, P, and III from tip end toward the switch end of the body. Then fit small rubber grommets into the tip and cable exit holes.

Slip over the free ends of the memory switch wires 1/2-in. lengths of small-diameter, heat-shrinkable tubing. Solder the leads to the switch lugs and shrink the tubing over the connections.

Over the free end of the coaxial cable, slip a 4-in. length of shrinkable tubing. Push it all the way down toward the board and shrink it. Pass the free end of the cable through its grommet-lined hole from the inside of the body and slip over it another 4-in. length of shrinkable tubing. Strip away 5 in. of outer insulation and remove and discard 4 5/8 in. of the braided shield. Being careful to avoid heat damage to the cable's inner insulation, pre-tin the braid on one side with solder. Strip 3/8 in. of insulation from a 5-in. length of stranded hookup wire and pre-tin the exposed wires. Then carefully tack-solder the wire to the shield stub. Slip the tubing down over the connection, overlapping it by 1/2 in., and shrink it.

Strip away 1/4 in. of insulation from the free ends of the inner conductor of the coax and the stranded wire. Solder a red-booted miniature alligator clip to the inner conductor and a black-booted clip to the stranded wire.

Next, make a 1/2-in. slit, lengthwise,

in one end of a 4-in. length of 1/2-in.-diameter shrinkable tubing. Slip the tubing over the board, slotted end toward the tip located on the foil side of the board. Locate and mark the positions of the LED lenses. Remove the tubing and punch or drill 1/8-in. holes in the marked locations. (Note: This tubing will *not* be shrunk during final assembly.)

To assemble the probe, slip the tubing into the probe body and line up the two sets of holes. Slide the board assembly, probe end first, into the body and push it home, orienting the LED lenses under their respective holes. Gently pull on the coaxial cable to take up the slack. Then screw on the switch cap.

**Testing The Probe.** Observing polarity, connect the alligator clips to a

variable dc source. With S1 set to the stretch mode, slowly advance from 0 to 5 volts. At 2.8 volts, the memory (P) LED should flash on then off as the potential is increased through 4.1 volts. This condition can be used to check for low voltages.

With the supply set to 5 volts, touch the probe tip to the common lead. The LO LED should light while the P LED comes on for 200 ms. When the common is removed from the probe tip, the LO LED should extinguish and the P LED should again light for 200 ms.

When +5 volts is applied to the probe tip, the same thing should be observed on the 1 LED. To check for memory action, place S1 in the memory mode and touch the probe tip to either common or +5 volts. LED P should come on and remain on until S1 is returned to the stretch mode. ♦

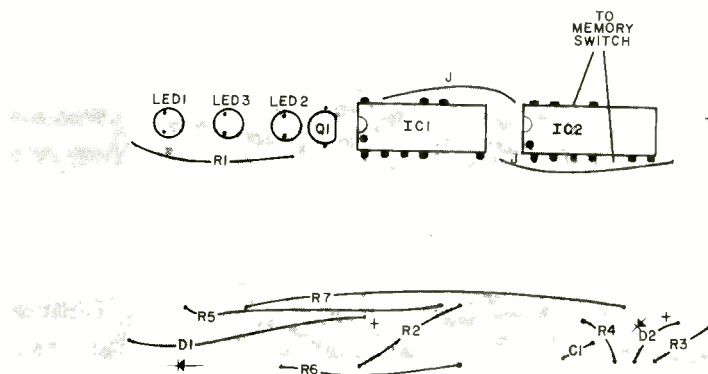
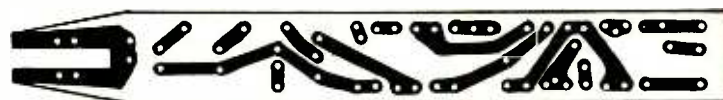

Fig. 2. Foil pattern (top) and layouts for both sides (below).

# The chances are excellent that... You have a talent other people are willing to pay for!

You're "handy" around your house, have the ability to fix things, and "make them work right"...that's why there may be a rewarding career for you in Electronics.

## A career in Electronics?

Absolutely. Because you're interested in *things*. How they work. Why they work. How to take them apart and put them back together. Plus . . . you've got a head for detail work.

## Your chances are excellent

With the right kind of *specialized* technical training, you can have a challenging, financially rewarding future waiting for you in Electronics. Think of the career opportunities . . . computers, aerospace, 2-way radio communications, radio/TV broadcasting, medical electronics, to name just a few.

And, surprisingly, you don't need a college degree!

All you need to do to qualify for one of these exciting career fields is to build upon the technical aptitude you already have . . . just put your hands and your head to work with a CIE Electronics career course.

## You learn by doing

The CIE method of instruction is the refinement of over 40 years of Electronics, independent home-study experience. It works. And you don't need *any* prior electronics experience. A CIE *career* course can take you from ground zero right up to training in Lasers, Microminiaturization, Radar, Analog Computers, and various applications in Communications.

In some CIE courses, you'll perform "hands-on" experiments and tests with your own CIE Experimental Electronics Laboratory. And, if TV technology and digital Electronics are your main interest, you can select from several courses that involve working with and



troubleshooting a TV. (And the TV is yours to keep, too!) This combination of "head and hands" learning *locks in* your understanding of the crucial principles you'll use on-the-job in your new career. But, don't kid yourself . . .

Electronics is not an "easy" science and CIE courses are not "snaps." Subject matter is technical, thorough, and challenging. It has to be. We're training you for a *career*. So the presentation of ideas is logical, written in easy-to-understand language . . . you progress step-by-step, at your own pace.

## CIE Education by mail

There is no need to "go back to the classroom" with CIE. Because you learn at *home* or wherever else is convenient. You keep your present job and income. No cross-town commutes. *You* decide when and where *you* study best.

Your eventual success . . . at CIE and in your electronics career . . . will be determined by your own motivation and self-discipline. *You can* do it. And CIE can show you how.



Patterns shown on TV and oscilloscope screens are simulated.

# If you want a career in servicing two-way radio communications equipment . . . you'll have to get a First or Second Class FCC Radiotelephone License.

## One good way to prepare for your license exam is a specialized home-study course from CIE...“the FCC License school.”

There's a gigantic potential market out there for communications equipment service skills. (For example, there are about 4 million mobile transmitters that are licensed by the FCC.) And that's just the beginning. Radio systems are also used in air and railroad traffic control; police, fire-fighting, and rescue vehicles; ship-to-shore communications; dispatching of fleet vehicles, such as taxis and trucks; assigning field service specialists; security networks; satellite communications; and many other new and growing applications. But before you can start a career servicing any radio system, you must have at least a Second Class FCC Radiotelephone License.

### How CIE Can Help You

We've been helping people prepare for the government-administered FCC License examinations since 1934. Our record speaks for itself: in continuing surveys, nearly 4 out of 5 CIE graduates who take the exams get their FCC Licenses. No wonder the people who know us best think of us as “the FCC License school.”

CIE independent study courses combine the necessary FCC License preparation with a thorough education in electronics technology. In fact, one course . . . “FCC License and Communications” . . . includes that in-depth instruction plus intensive training in the specific career skills needed to maintain and repair two-way FM radio equipment. In addition, CIE offers five other career courses which include FCC License preparation. Some even provide valuable “hands-on” training with professional equipment such as a solid-state oscilloscope, a Zenith color TV, and a color bar generator.

### Learning New Skills Is No Picnic

But, don't kid yourself. You really have to want success if you're going to build your skills properly. CIE independent training is no snap even with our Auto-Programmed® Lessons. It takes work and it takes time. But when you make it, the rewards can be worth it all.

So, if communications troubleshooting looks like the career field you want . . . and want it enough to roll up your sleeves and work for it . . . let us know.

### Send for CIE's FREE School Catalog

Mail the card or coupon or write and mention the name and date of this magazine. We'll send you a

copy of CIE's FREE school catalog — plus a complete package of independent home-study information. For your convenience, we'll try to have a representative contact you to answer your questions. Mail the card, coupon, or your letter to: CIE, 1776 East 17th St., Cleveland, OH 44114.

**CIE** **Cleveland Institute of Electronics, Inc.**  
 1776 East 17th Street, Cleveland, Ohio 44114  
 Accredited Member National Home Study Council

Yes, I want your FREE school catalog and career information package.

PRINT NAME \_\_\_\_\_ APT. \_\_\_\_\_  
 ADDRESS \_\_\_\_\_ STATE \_\_\_\_\_ ZIP \_\_\_\_\_  
 CITY \_\_\_\_\_  
 AGE \_\_\_\_\_ PHONE (area code) \_\_\_\_\_  
 All CIE career courses are approved for educational benefits under the G.I. Bill.  
 Check box for G.I. Bill information:  Veteran  Active Duty

EH 21

## ALTERNATELY FLASHING TAILLIGHTS

BY TERRY A. WILLIAMSON

**A** HEADLAMP up front to light your way and let people know you're coming toward them is great to have for night cycling. But it isn't enough if you leave your rear unprotected from oncoming motorists. For rear protection, you want something that will attract attention, like the flashing light system described here. Two lamps alternately flash on and off at a rate of about once a second to draw attention.

You can build the biker's rear safety flasher system for less than \$10, exclusive of generator.

**About the Circuit.** As shown in the schematic diagram, power for the flashing light system is obtained from a standard bicycle generator. The generator should be rated at 6 volts and be capable of delivering 3.3 watts or more to the load.

The circuit used to pulse lamps *I1* and *I2* is a relay (*K1*) driven by 555 timer *IC1* at a frequency of about 0.9 Hz with the component values shown. (Other rates can be obtained by manipulating the values of *C1* and *R2* in the formula  $F = 1.5R2 \times C1$ .)

Lamps *I1* and *I2* flash alternately because of the arrangement of *K1*'s contacts. When one lamp is on, the other is off. Then, when the next pulse from *IC1* energizes *K1*, its contacts close in the opposite direction, powering the second lamp and extinguishing the first.

Dc power for driving the circuit is obtained by rectifying the ac coming from the generator (actually an alternator) through *D1* and filtering it with *C3*. Since the output of the generator

often contains spikes with amplitudes in the 15- to 20-volt range, zener diode *D2* is used to protect *IC1* from over-voltage damage.

Diode *D3*, connected across the winding of *K1*, protects *IC1* from the inductive "kick" (back emf) that results when power is removed suddenly from the relay's coil.

The circuit does not use or need a power switch. Power is applied and removed from the circuit simply by engaging and disengaging the generator.

**Construction.** Since the circuit is very simple, it can be assembled on a printed circuit or a perforated board. Parts placement is not critical, whichever method of assembly you choose.

Relay *K1* should be a 6-volt unit with a coil resistance of about 500 ohms. Its contacts should be rated for at least 1 ampere at 6 volts. Bolt the relay directly to the circuit board. Then, after making all necessary connections to its coil and contacts, use silicone rubber cement to anchor its plastic cover to the board.

The two #63 auto backup lights used for *I1* and *I2* should be housed in 2½-in. (6.35-cm) diameter red-lensed holders, such as the Pathfinder #667 red taillight assemblies. The lights can be mounted anywhere convenient on the bike, such as a carrier or a mudguard. If you have a racing-type bike that has neither carrier nor mudguard, mount the lamp assemblies on the rear-wheel fork struts, but take care to avoid interfering with brake and shift cables. ♦



**B** ICYCLING on our roads can be a hazardous proposition, especially at night when visibility is drastically reduced. Manufacturers of bicycles try to circumvent the poor visibility problem by providing reflectors at strategic locations on their bikes to make them visible after dark.

The problem with reflectors is that they depend on an outside source of light to render them—and the bike on

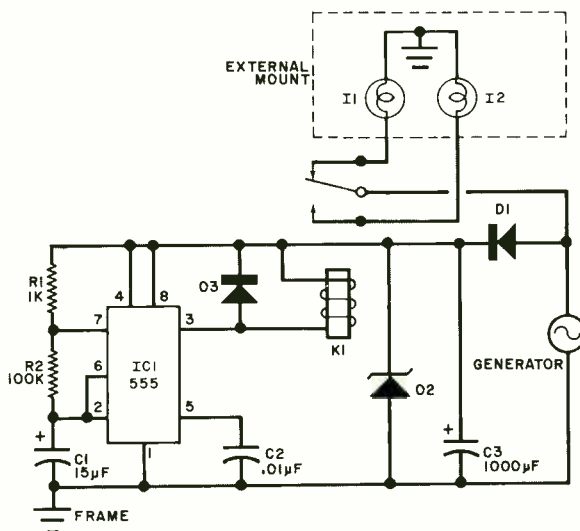

### PARTS LIST

- C1—15- $\mu$ F, 25-volt electrolytic capacitor
- C2—0.01- $\mu$ F, 25-volt disc capacitor
- C3—1000- $\mu$ F, 25-volt electrolytic capacitor
- D1, D3—1N4001 diode
- D2—12-volt, 1-watt zener diode (Motorola HEPZ 0415 or similar)
- I1, I2—#63 auto backup lamps
- IC1—555 timer integrated circuit
- K1—6-volt, 500-ohm relay (Archer No. 275-004 or similar)
- R1—1000-ohm, ½-watt resistor
- R2—100,000-ohm, ½-watt resistor
- Misc.—Suitable enclosure; red-lensed taillight assemblies (see text); pc or perforated board; 6-volt, 3.3- to 6.6-watt generator (if you don't already have one); rubber grommets; hookup wire; solder; machine hardware; etc.

# TWO PROJECTS ADD SAFETY TO NIGHT BIKING

which they are mounted—visible. Needless to say a device that is a light source itself—a lamp—is infinitely more preferable and safer than a passive reflector. Therefore, we present in these pages two different types of lights that can make your night biking safer. One is a headlight that combines the advantages of both batteries and a generator. The other is an attention-getting blinking taillight. ♦

## "ALWAYS-ON" BIKE LIGHTS BY CHARLES R. CLINKENBEARD

**T**RADITIONALLY, you powered the lights on your bike with batteries or you opted for generator power. Batteries deliver the same amount of power to the lamp whether the bike is moving or at a standstill. However, they are quickly depleted of their charges, requiring periodic replacement. Generators, on the other hand, hardly ever need replacement. Their disadvantage is that variable power is delivered to the lamp, depending on the speed at which the bike is moving. Faster speeds give greater light output than slower speeds, and when the bike is stopped, there is no light at all.

The best way to remedy the situation, it would appear, is to team batteries with a generator. This way you can extend the life of the batteries by using the generator while in motion. Furthermore, you get full light output when the bike is stopped because the batteries take over. And that is just what the following is all about.

**System Design.** You can't just connect batteries in series with each other, hook them directly across a generator and expect the system to work. It won't because the impedances of the power sources are much lower than the resistance of the light they are to power. The result of such an arrangement would be to have most of the power flowing from one source to the other with the lamp remaining dark.

What a battery/generator power system needs is isolation between the two sources, plus a scheme that automatically switches to battery power when

the output of the generator falls off and then switches back again when the generator's output picks up. This is what the circuit shown in the schematic diagram is designed to do.

Assuming that there is no generator power and *S1* is closed, diode *D1* would be reverse biased. Transistor *Q1* is cut off as a result of an absence of base current. So, the generator would be electrically isolated from battery *B1*. Under these conditions, the only power reaching headlight *I1* and tail light *I2* would come from the battery.

Now let us assume that the generator is delivering an output. When the lead of the generator connected to the anode of *D1* is positive (the generator's output is ac rather than dc), current flows through *D1* to *I1* and *I2*. Simultaneously, the current also flows through *D2* and charges *C1*. When the potential across *C1* comes within 0.6 volt of the battery potential, *Q3* is cut off, cutting off *Q2* as well and isolating *B1* from the now generator-powered lamp circuit. Transistors *Q2* and *Q3* will now remain off for as long as the generator is delivering power.

As the bike is slowing to stop and the output of the generator falls off, the potential across *C1* will decay. When it falls to more than 0.6 volt below *B1*'s potential, *Q2* and *Q1* will switch on and pass power to the lamps from the battery.

**Construction.** Little need be said with reference to construction aside from the fact that the components should be housed in a metal or other suitable utility box. ♦

### PARTS LIST

- B1—6-volt lantern battery
- C1—100- $\mu$ F, 25-volt electrolytic capacitor
- D1,D2—1N4002 diode
- I1,I2—6-volt, 0.1-ampere bicycle light
- Q1—2N2102 transistor
- Q2—2N3055 transistor
- Q3—2N2905 transistor
- R1—100-ohm, 1/2-watt resistor
- R2—20,000-ohm, 1/2-watt resistor
- S1—Spst switch
- Misc.— Suitable enclosure for circuit; perforated board and push-in solder clips; suitable lensed housings for I1 and I2; hookup wire; solder; machine hardware; etc.

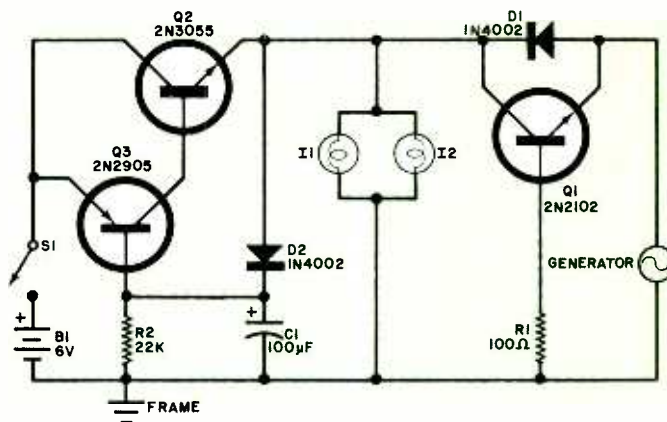

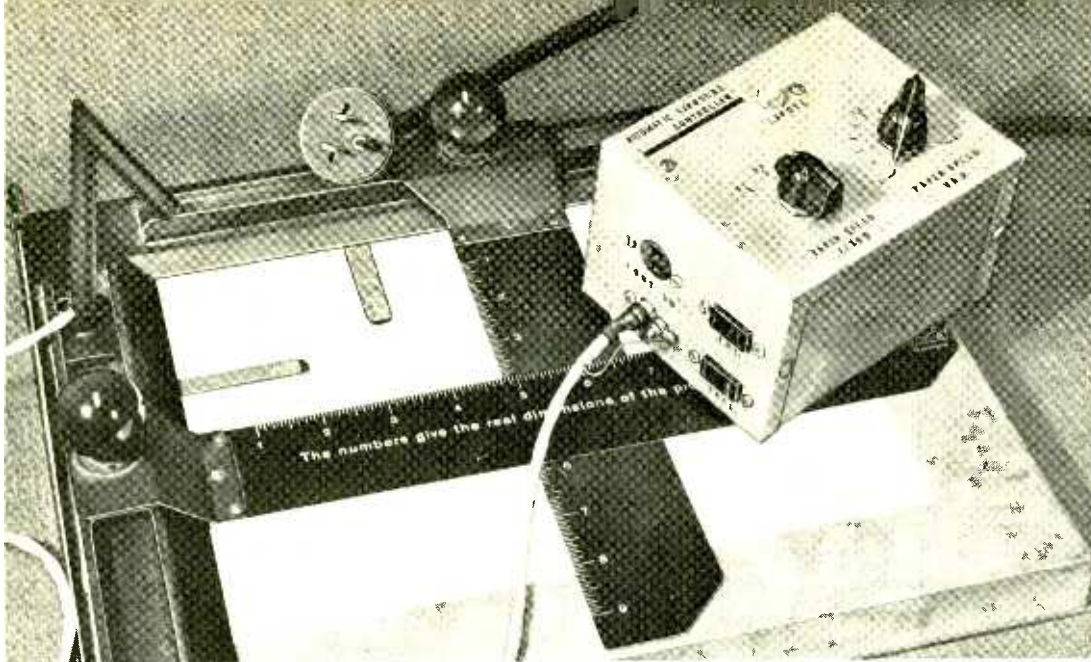

Selects the proper exposure time and cuts down on photo paper waste

# AUTOMATIC PHOTO ENLARGER CONTROLLER

BY JOSEPH GIANNELLI

If you're presently making photographic enlargements using a light meter, a gray scale, test strips, or some other such device, you'd probably welcome a simple pushbutton device that automatically selects the correct exposure and exposes your print for precisely the correct time. Well, with this automat-

ic exposure controller, you can have such a device for much less than you would pay for a professional unit.

The controller is a unique new device for the amateur photographer. A search through camera catalogs and visits to photo suppliers will quickly reveal that the only thing remotely resembling this

device is the simple light meter—and the resemblance is remote indeed. You can build the automatic exposure controller for about \$22.

**How It Works.** The sensor used in the controller (*LDR1* in Fig. 1) is sensitive to the entire visible spectrum, adapting the

## PARTS LIST

- C1—1- $\mu$ F, 25-volt electrolytic capacitor
- C2—250- $\mu$ F, 25-volt electrolytic capacitor
- C3, C4—1- $\mu$ F, 25-volt Mylar capacitor
- C5—2- $\mu$ F, 25-volt Mylar capacitor
- D1—D4—1N458 diode
- F1—1-ampere fuse
- IC1—NE555 timer IC (Signetics)
- J1—Phono jack, insulated from chassis
- K1—12-volt, 1640-ohm relay (Sigma No. 65FP1A-12DC)
- LDR1—Light-dependent resistor (Clairex No. CL905HL)
- PL1—Phono plug
- Q1—MPF-102 n-channel field effect transistor (Motorola)
- R1, R3—100-ohm, 1/2-watt resistor
- R2—See text
- R4—15,000-ohm, 1/2-watt resistor
- R5—100,000-ohm, 1/2-watt resistor
- R6—2400-ohm, 1/2-watt resistor
- R7—500-ohm linear potentiometer
- S1—Spst switch
- S2—Spst normally open pushbutton switch
- S3—3-pole, 3-position nonshorting switch (Centralab No. PA1006)
- SO1-SO3—Chassis-mounting ac receptacle
- T1—24-volt ac, center-tapped power transformer
- Misc.—5"x4"x3" metal chassis box; spade lugs; printed circuit board or perforated phenolic board with clips; three-wire line cord with plug; rubber grommet; two-conductor shielded cable for cell assembly; hookup wire; solder; etc.

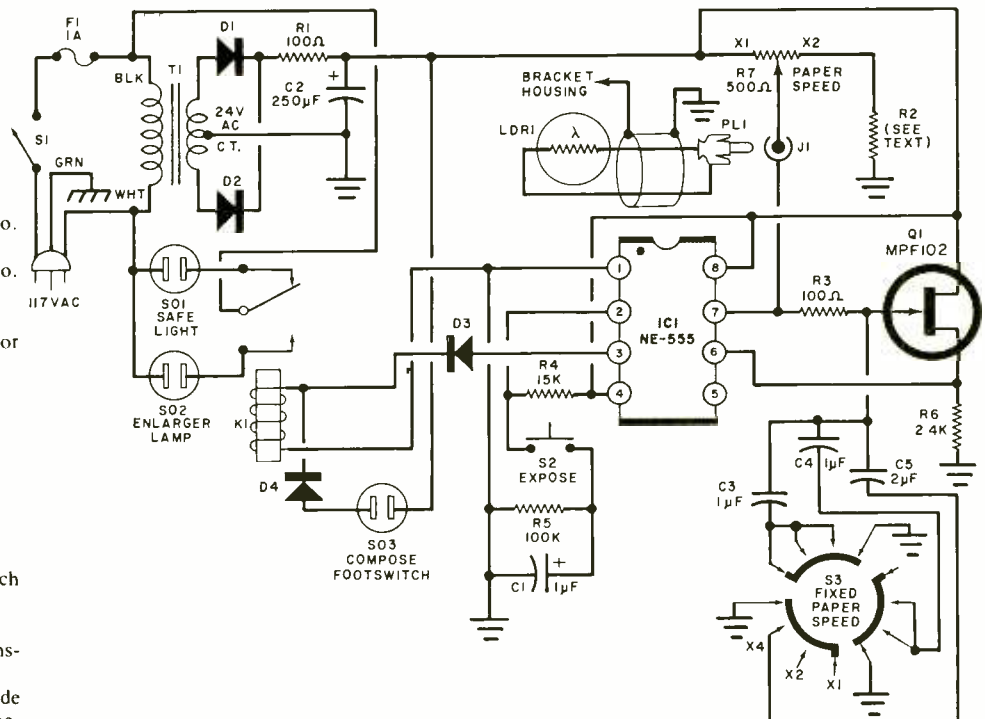

Fig. 1. Light dependent sensor element changes circuit values to control enlarger.

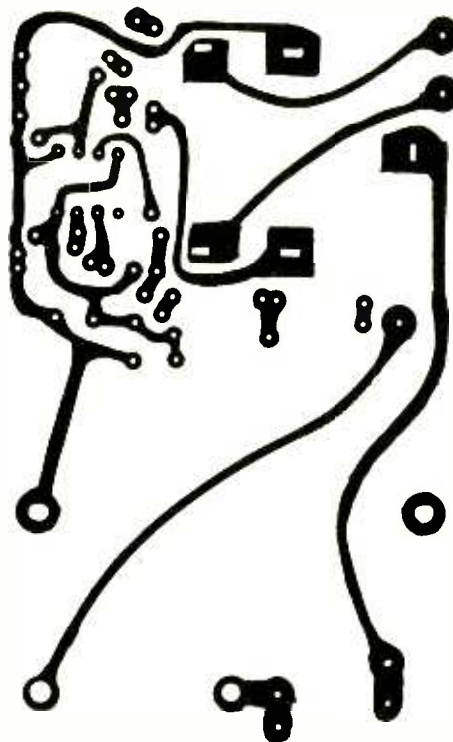
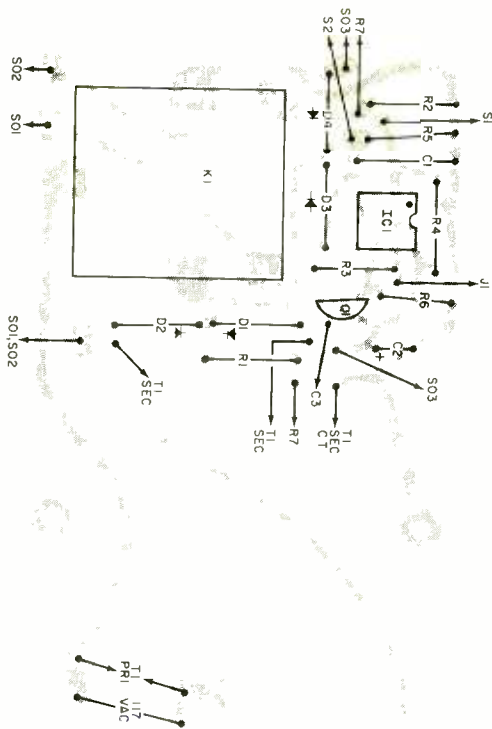

Fig. 2. Foil pattern for pc board is at right, component layout shown at left.

system to color printing and multi-contrast paper. It is mounted on the edge of the easel where it "looks" down at the photographic paper and picks up the reflected light from a large area of the projected image the moment EXPOSE pushbutton switch S2 is depressed. A certain resistance value for a given light level is then established by LDR1. This resistance, coupled with C3, determines the on time of the enlarger lamp plugged into SO2 to extinguish.

Field effect transistor Q1 increases the input resistance at pin 6 of IC1, allowing larger resistance swings for LDR1 with smaller capacitance values for C3, C4, and C5. This eliminates the need of inherently leaky electrolytics for these capacitors but requires that low-leakage Mylar units be used in the fixed paper speed circuit.

When pushbutton switch S2 is depressed, a negative-going trigger pulse is applied to pin 2 of IC1, sending the output at pin 3 to the high state. This, in turn, energizes K1 and turns on the enlarger lamp plugged into SO2. The initiation of the expose trigger also opens up the IC's discharge circuit at pin 7, allowing the C3, C4, or C5 (whichever is switched into the circuit via S3) voltage to rise through LDR1 as a function of the reflected light level seen by the LDR.

The voltage continues to rise at pin 6, where it is compared with an intrinsic control voltage; that appearing at pin 5 of IC1 (equal to 0.667 the supply volt-

age). When the rising voltage at pin 6 equals the fixed control voltage at pin 5, the flip-flop in IC1 changes state and discharges the paper speed capacitor through R3 and de-energizes K1. As a result, the enlarger lamp at SO2 extinguishes and the safe light plugged into SO1, if any, comes on.

VARIABLE PAPER SPEED control R7 provides smaller changes in time (as opposed to the rough changes provided by C3, C4, and C5 through S3). Control R7 multiplies the fixed values introduced by the fixed paper speed capacitors by a factor of 2. It should be a linear potentiometer for easy calibration (see lead photo) after circuit is assembled.

A simple OR circuit, D3 and D4, is provided for permitting a footswitch plugged into SO3 to be used to turn on the enlarger lamp via K1. This feature frees both hands for the job of focusing and composing the projected image.

The automatic exposure controller is extremely linear in its performance. With the components specified, the timing range is from 1 second to more than 2 minutes, which more than covers the various paper speeds. Also, the system is insensitive to line voltage variations.

**Construction.** For the sake of neatness and convenience, it is suggested that you assemble the controller on a PC

Fig. 3. View of completed controller. Bracket holding the LDR sensor is at extreme left.

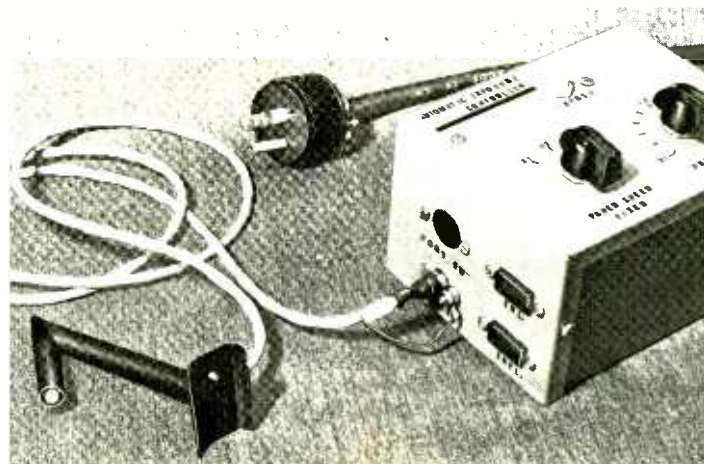

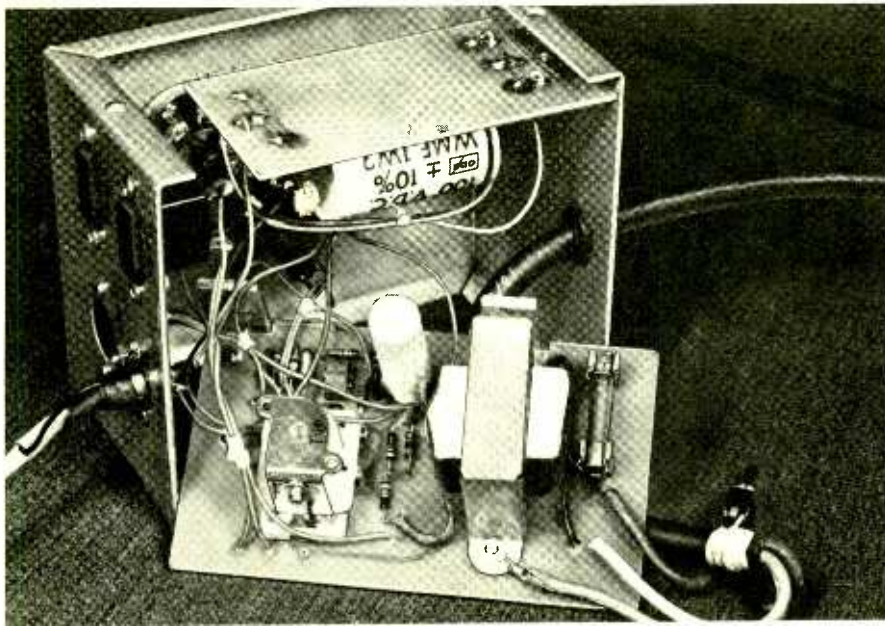

Fig. 4. Photo shows inside of prototype chassis with bottom removed.

board (see Fig. 2 for etching and drilling guide and components placement diagram). The prototype was assembled with two PC boards; one for the main circuitry and the other for the bulky C3, C4, and C5 capacitors. However, you can obviate the need for the capacitor board by joining one lead of each capacitor in common, slipping a length of insulated spaghetti over the common lead, and soldering this lead to the hole marked C3 on the main board. The free leads of C3, C4, and C5 can now be soldered directly to their respective S3 lugs.

Aside from the normal precautions to be taken with any solid-state circuit, assembling and wiring the PC board is simple. (If you elect to use perforated phenolic board construction, it is suggested that you use a socket with IC1; do not solder directly to the IC pins.)

Mount J1, R7, SO1-SO3, and S1-S3 on the top half of the case, and route the line cord through a grommet-lined hole as shown in Figs. 3 and 4. Connect the earth-ground (green) power cord wire to one of the mounting lugs of T1 and case ground. (Note: In the prototype, no power switch was used. But the use of S1, mounted to the case top and connected in series with the black power line lead and F1, is recommended.)

Details for fabricating the cell bracket for LDR1 are shown in Fig. 5. Use only solderable brass or copper tubing. You can make the cell holder as shown, cutting and soldering it as required. Alternatively, you can fill the tubing with dry sand or slide into it a tubing bender spring and heat the tubing just enough to permit its bending without crumpling. Either method should yield the same re-

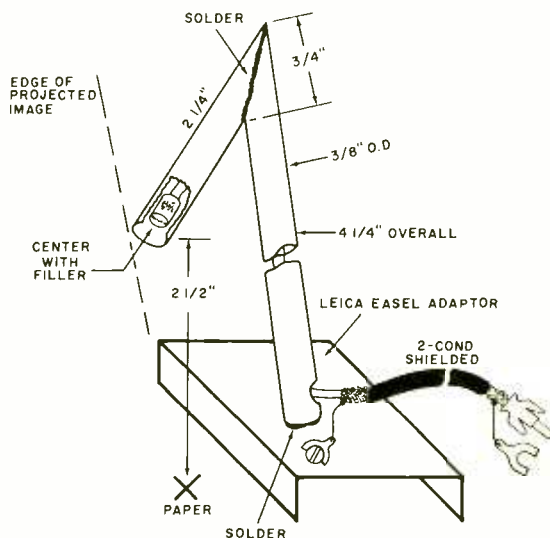

Fig. 5. Details of the cell bracket which holds LDR. Tubing is brass or copper, obtainable in hobby stores, and painted black.

sults with respect to orientation over the photographic paper when the bracket is mounted on the easel.

After drilling and deburring the cable exit hole and soldering the tubing to the modified Leica easel adaptor, spray the entire assembly with flat black paint. When the paint dries, slip the two conductors of the shielded cable up the tubing and solder them to the leads of the LDR. Slip the LDR, with enough filler around it to hold it in place, into the tubing. Solder a spade lug to the cable shield at each end and a phono plug to the insulated conductors at the end of the cable that goes to the control box.

At this point, the entire system should be assembled, minus R2. Tack solder a 10-megohm resistor across the lugs of J1 and a 10,000-ohm potentiometer across the points marked R2 on the PC board. Set the pot to its midpoint. Plug the line cord into an ac outlet and your enlarger lamp into SO2. Set R7 to its minimum-resistance position, turn on S1 and momentarily depress S2. Time out the cycle. Then set R7 to its maximum-resistance position, depress S2, and time out the cycle. If there is not a 2:1 ratio between this and the first position of R7, adjust the tacked-in potentiometer until you get this ratio.

Turn off the power, unplug the line cord and enlarger lamp cord, and unsolder the 10-meg resistor and pot (do not disturb the latter's setting). Use an ohmmeter to measure the pot's resistance and select a fixed resistor of a value close to your reading for R7, soldering it in the appropriate location on the PC board. Then assemble the case. The controller is now ready to use in your darkroom.

**Making A Print.** It is now necessary only to determine the settings of the FIXED and VARIABLE PAPER SPEED controls for the types of paper you are using. Place the LDR bracket to look at an area of interest, avoiding hot spots, and simply make a small enlargement at different settings of the controls. Use low numbers for lighter and high numbers for darker areas. Record the best setting on your package of paper. This setting is now always used for that paper, regardless of the magnification and film density or filter. A new setting will be required for other grades of paper.

If Kodak Polycontrast paper is used, the controller will automatically adjust for filters and the inherent paper speed change, using only one setting, and will also compensate for filter pack changes when printing color. ◇



# LOW-COST METAL LOCATOR

*An easy-to-build locator that detects buried metal objects at depths of 6 inches.*

BY JOE A. ROLF

**M**OST inexpensive metal locators are "heterodyne" types where the output frequencies of a fixed and variable oscillator "beat." The fixed-frequency oscillator serves as a reference, while the other oscillator has a sensing loop that changes its frequency when brought near metal. The resulting heterodyne (difference frequency between the two oscillator signals) is amplified and fed to a speaker or meter.

The low-cost metal locator described here is a heterodyne unit. But it is less expensive and easier to build than most because it can be used with an ordinary portable AM broadcast-band receiver. The radio already contains everything but the sensing-oscillator circuit. The necessary oscillator and sensing loop are easily added.

**How It Works.** The schematic diagram for the sensing oscillator is shown in Fig. 1. Essentially, it is a tuned-gate, field-effect transistor ( $Q1$ ) oscillator. Variable capacitor  $C2$  permits the circuit to be tuned across the middle frequencies of the AM band.

The sensing oscillator is first tuned exactly to a broadcast station (which must be done far away from any metal objects). Subsequently, any metal in the vicinity of the sensing loop ( $L1$ ) will change the oscillator's frequency to produce a beat note at the receiver's speaker. Moving the loop away from the metal will cause the beat note to cease.

**Construction.** The oscillator circuit can be built into any 3¼-in. by 2½-in. by 1½-in. metal utility box. To simplify



assembly, use a piece of perforated phenolic board and solder clips to mount the oscillator components as shown in Fig. 2. Referring to Fig. 3, machine the top half of the utility box and mount on it  $B1$  (in a battery hold-

er),  $C2$ ,  $J1$ , and  $S1$ . Then mount the board assembly with #6 machine hardware and ⅜-in. metal spacers. Refer back to Fig. 2 and interconnect the chassis-mounted and on-the-board components.

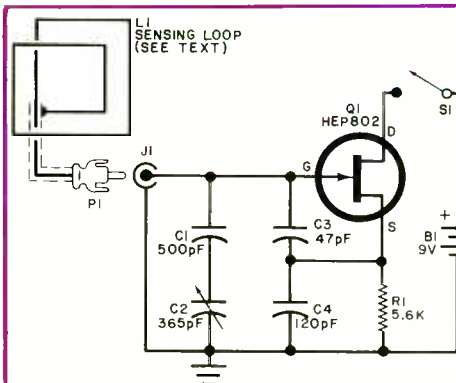

*Fig. 1. Schematic of sensing oscillator that beats against any broadcast-band receiver.*

## PARTS LIST

- $B1$ —9-volt transistor battery
- $C1$ —500-pF ceramic capacitor
- $C2$ —365-pF miniature variable capacitor
- $C3$ —47-pF ceramic capacitor
- $C4$ —120-pF ceramic capacitor
- $J1$ —Phono jack
- $L1$ —See text
- $P1$ —Phono plug
- $Q1$ —2N3819 or HEP-802 (Motorola) field-effect transistor
- $S1$ —Spst slide or toggle switch
- Misc.—3¼" × 2½" × 1½" utility box; perforated phenolic board and solder clips; No. 32 enameled wire for  $L1$ ; ¼" outer-diameter aluminum tubing or broom handle, cut to 36" length; coil form for  $L1$  (see text); 36" Belden No. 8411 microphone cable; control knob; #6 machine hardware; spacers; battery holder; phone jack and plug for sensing coil cable (optional); solder; solder lug; etc.

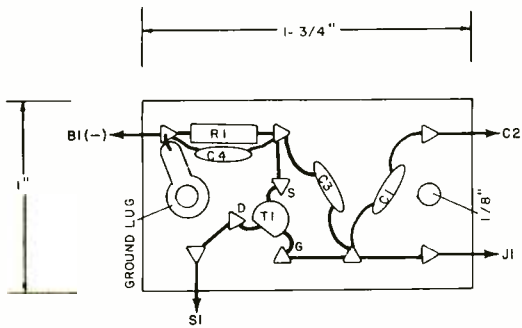

Fig. 2. Diagram shows how components are laid out on perforated phenolic board.

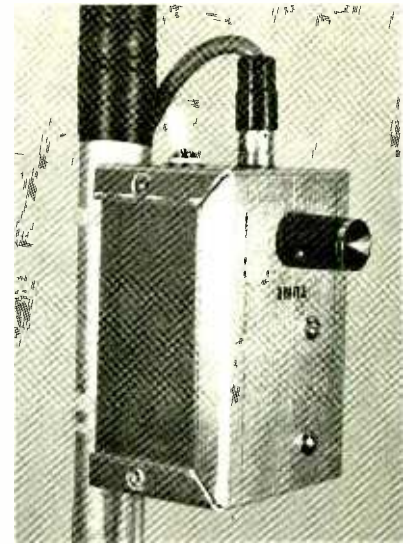
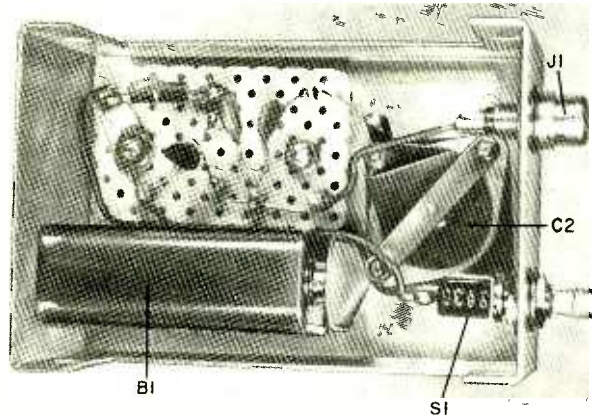

Fig. 4. Attach bottom half of box to handle and mount the top half as shown.

Fig. 3. Photo of prototype showing how the boards and components go into the chassis.



Drill two 1/8-in.-diameter holes and mount the bottom half of the utility box to the handle you plan to use for your metal locator. For the handle, you can use either 3/4-in.-outer-diameter aluminum tubing or an old broom handle. Whichever you choose, cut it to a length of 36 in. and wrap the top with several layers of electrical tape to provide a comfortable grip. Then mount the bottom half of the utility box to the aluminum tubing with sheet metal screws (wood screws if you are using a broom handle) as shown in Fig. 4.

An 8-in. by 6-in. lid for a plastic freezer container makes an ideal form for winding sensing coil *L1*. For durability, however, it should be made rigid by adding a 6-in. by 3-in. piece of 1/8-in. Bakelite or phenolic board as shown in Fig. 5. The board that adds rigidity can be fastened with three sets of #6 machine hardware, one set of which also anchors into place the U bracket required for fastening the sensing loop assembly to the handle of the metal locator.

Sensing loop *L1* consists of 20 tightly wrapped turns of No. 32 enameled wire around the rim of the freezer container lid. Secure the turns with coil dope and a turn or two of electrical tape. You can either bring the ends of *L1* out to a phono jack mounted on the freezer container lid, or solder the cable that interconnects loop and oscillator directly to the

loop's leads. The connecting cable itself should not exceed 36 in. in length and should be a low-capacitance variety like the Belden No. 8411 used for lapel microphone cables.

**In Use.** To operate the metal locator, tune your transistor receiver to a strong station in the middle of the AM band and slowly tune *C2* back and forth. A beat note will be heard when you cross the station tuned on the receiver. Carefully adjust *C2* until the beat note disappears, or is as low as possible. (Do not forget to do this with the sensing loop far away from any metal objects.) Now, sweep the sensing loop near to a metal object; the tone should re-occur.

The sensing loop described above is most useful for general-purpose work, but other sensing-coil configurations

can be built for specific applications. A round (6-in.-diameter) plastic container lid with 25 turns of enameled wire can be used for exploring smaller areas, while a ferrite antenna coil (designed for use in transistor radios) inside a length of plastic tubing will provide a wand-type sensor that is useful for locating ducts, studs, and pipes in walls. Whichever sensor you plan to use, it is important that the cable between loop and utility box be less than 36 in. long.

While using the metal locator, you will discover that the audible indication you get is proportional to the size of the object being sensed, its depth below the surface of the soil, and soil condition. An object the size of a soup can at a depth of 6 in. is easily detected in dry soil, but at a lesser depth in wet soil. With practice, it is possible to determine the size and depth of an object—a good thing to know before you begin digging. ♦

Fig. 5. The sensing coil is wound on plastic freezer container lid that is stiffened with Bakelite or phenolic. Phono jack is used to connect loop to oscillator cable.





BUILD THE

# MINIVOLTER

BY JOHN F. HOLLABAUGH

*Twelve ranges from 500  $\mu$ V to 100 volts full scale.*

*Doubles as ohmmeter down to 0.02 ohm.*

*Use to measure current down to 10 nA.*

*Costs under \$20.*

**N**OW you can have a voltmeter that measures from 500 microvolts to 100 volts full-scale, in 12 overlapping ranges, costing less than \$20. Designed for use on circuits where a little voltage makes a big difference, the sensitive Minivolter is ideal for use on solid-state equipment. In these low-voltage circuits, many conventional meters can't be used because of their relatively low input resistance. The input resistance of the Minivolter is one megohm per volt, drawing a current of one  $\mu$ A.

The Minivolter can also measure ac voltages if a 1.2 multiplier is used. And it will serve to indicate r-f levels in orienting TV antennas and to peak the low-level stages of transmitters.

**How It Works.** As shown in Fig. 1, op amp *IC1* is used as a voltage follower and *IC2* as a linear rectifier. Any voltage applied to the (-) input of *IC2* is multiplied by the gain of the op amp and inverted. The difference between the input (pin 2) and the output (pin 6) is high enough that the fixed voltage drop across *D1* and *D2* can be hidden by the drop across the series portion of *R15*. So the difference can be considered not to exist. Also, the diode barrier potential (0.7 volt) does not place a lower limit on the value being

measured since any practical value of voltage applied to the input causes some current to flow through the meter circuit.

If a positive voltage is applied to pin 2 of *IC2*, current flows through *D2*, controlled by *S3* (PROBE +), the meter, and part of *R15*. If a negative voltage is applied to pin 2 of *IC2*, the current flow is from the positive output and through *D1* back to the input. The current is actually from the input source since no current can be taken from the input terminal of the op amp. This current is between two and three times the meter rating for full-scale deflection. (In the prototype, the current was 2.8 times the 50- $\mu$ A meter current or 140  $\mu$ A.) The sensitivity of the meter has been reduced from 30,000 ohms/volt to 6800 ohms/volt, but we have gotten around the diode barrier drop. For a full-scale indication of 500 microvolts, the input resistance of *IC2* now looks like 3.6 ohms (500/140), which is not very good for a voltmeter. Thus it is necessary to use *IC1* as a voltage follower.

The voltage follower has a high input impedance and low output impedance due to the high open-loop gain of the 741 op amp. This makes it easy to match the high input impedance required of a voltmeter to the

low impedance required by the linear rectifier.

Some compromises have been made in the design of the range selection circuit due to the high offset current of the 741 op amp. A voltage-divider type of selection (as in conventional VTVM's) would be preferred because of the better input resistance on low ranges. However the voltage divider would have a value of shunting resistance across the input of the voltage follower which would require a rezeroing of the meter each time the range is switched. With the conventional 10-megohm resistance, the bias voltage generated across the input would be  $10 \times 10^6$  times 500 nA or 5 volts for the 500-microvolt range. Thus the conventional resistor approach was used instead of a voltage divider.

**Construction.** Most of the components can be wired point-to-point. A small board is required to mount the sockets for the IC's. Two 8-pin "mini-DIP's" can be accommodated in one 16-pin socket.

The potentiometers (except for *R17*) can be fastened with epoxy cement at convenient locations within the cabinet. Once they are adjusted, it is not necessary to have access to them. Install *R17* on the rear apron for easy access. Connect the range selector resistors to the appropriate terminals on *S1*. As noted in the Parts List, the high-value resistors can be made up of smaller units.

The 9-volt power supplies are made up of conventional AA cells in plastic holders.

**Calibration.** Before applying power to the Minivolter, connect a 10,000-ohm potentiometer across the meter and set the potentiometer to its minimum value. Adjust *R13* and *R14* to the far ends of their adjustments. Then back them off about 13 turns. Set *R17* to its midposition, and set *R16* to its maximum value.

Apply power to the Minivolter. Adjust the potentiometer across the meter until the meter gives an upscale reading. Then adjust *R13* and *R14* to make this reading a minimum. Progressively increase the value of the meter-shunting potentiometer and adjust the two trimmer potentiometers to obtain a zero until the shunting potentiometer can be removed from the circuit. Trim *R13* and *R14* a final time.

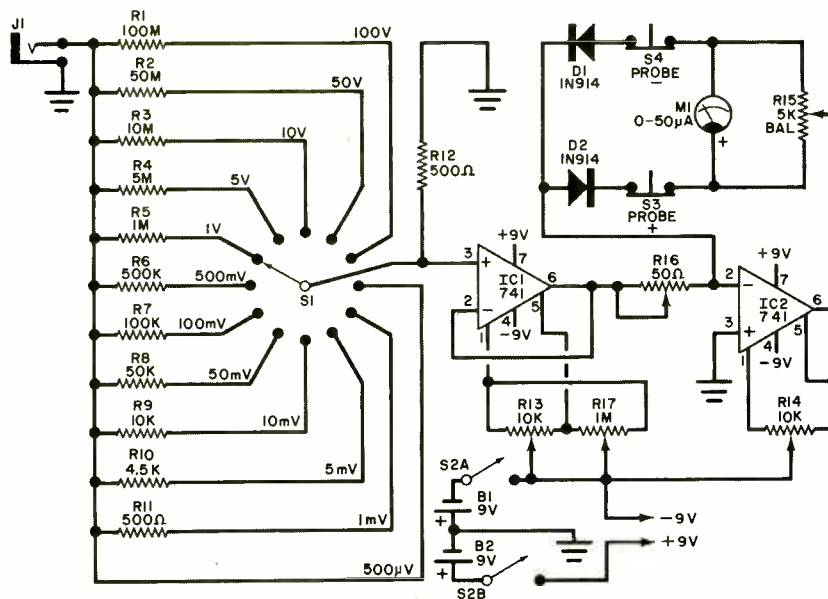

### PARTS LIST

- B1, B2—6 AA cells each  
 D1, D2—1N914 diode  
 IC1, IC2—741 op amp  
 J1—Phono jack  
 M1—0-50- $\mu$ A meter (Radio Shack No. 22-051 or similar)  
 Following resistors are  $\frac{1}{2}$ -watt, 5%:  
 R1—100 megohms (five 20 megohms in series)  
 R2—50 megohms (five 10 megohms in series)  
 R3—10 megohms  
 R4—5 megohms  
 R5—1 megohm  
 R6—500,000 ohms  
 R7—100,000 ohms  
 R8—50,000 ohms  
 R9—10,000 ohms

- R10—4500 ohms (two 9100 ohms in parallel)  
 R11, R12—500 ohms  
 R13, R14—10,000-ohm, miniature, multiturn trimming potentiometer  
 R15—5000-ohm, miniature multiturn trimming potentiometer  
 R16—50-ohm, miniature multiturn trimming potentiometer  
 R17—1-megohm potentiometer  
 S1—Single-pole, 12-position rotary switch (Radio Shack 275-1385 or similar)  
 S2—Dpst switch  
 S3, S4—Normally closed momentary-action pushbutton switch  
 Misc.—IC socket(s), battery holders (Radio Shack 270-384), battery clips, suitable enclosure (LMB No. N463), mounting hardware, rubber feet (4), wire, solder, etc.

Fig. 1. IC2 forms a linear rectifier for the meter, while IC1 is a voltage follower to give high input impedance.

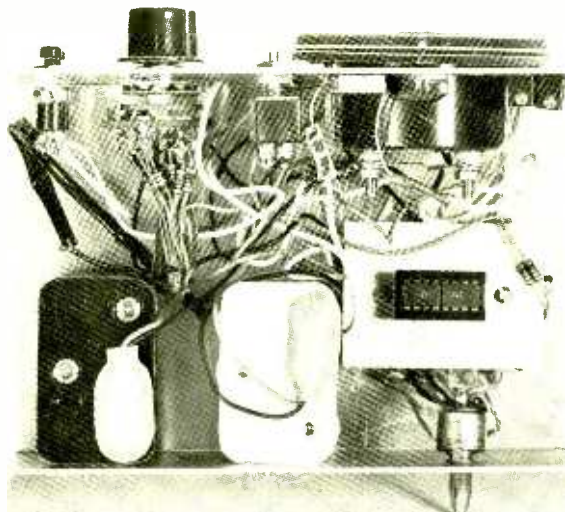

Photo shows how components were laid out in prototype.

Set S1 to a range suitable to measure a voltage known to be accurate (voltage reference or battery) and adjust R16 until the meter indicates the known voltage. Disconnect the reference and rezero the meter with R13 and R14. Repeat these last two steps until calibration and meter zero are obtained.

The last part of calibration should be repeated if the meter tends to drift because of temperature effects on IC1. This drift will be about 1/50 of the meter range. After calibration, if the meter has been out of operation for some time, the drift will cause an upscale deflection when the Minivoltmeter is first turned on. Do not re-adjust for this condition; it will disappear after a few minutes of warm-up.

To balance the polarity of indication, alternately apply the known dc voltage to the input and, operating the appropriate switch, adjust R15 to remove half of the difference of each reading. Do this until both readings are the same to insure the independence of polarity at the meter input.

**Use and Applications.** After turning on the Minivoltmeter, allow a couple of minutes for the IC's to warm up, noting that the meter goes to the zero mark. If it does not do so after a reasonable period, adjust R17 to obtain a zero. Make this adjustment with S1 in the 100-V position.

One can think of many unusual uses for the Minivoltmeter. Here are some examples:

- It can measure the voltage across a junction of dissimilar metals when heated (thermoelectric effect) or the voltage generated across a conventional glass-enclosed semiconductor diode when exposed to light.
- Voltages across a solder joint or connector can be measured for either an ac or dc drop with normal current flowing through the circuit.
- With a loop of wire connected across the input, the Minivoltmeter can be used to trace stray magnetic fields from power transformers, power lines hidden in walls, etc.
- By connecting the Minivoltmeter across an unknown resistor having a 1-mA current flowing through it, the instrument becomes an ohmmeter with readings down to 0.02 ohm.
- Switching to the 500- $\mu$ V range, the Minivoltmeter can be used as a 1- $\mu$ A meter having an internal resistance of 500 ohms. (It can measure currents down to 10 nanoamperes.)

# AN IGNITION TIMING LIGHT FOR IMPROVING GAS ECONOMY

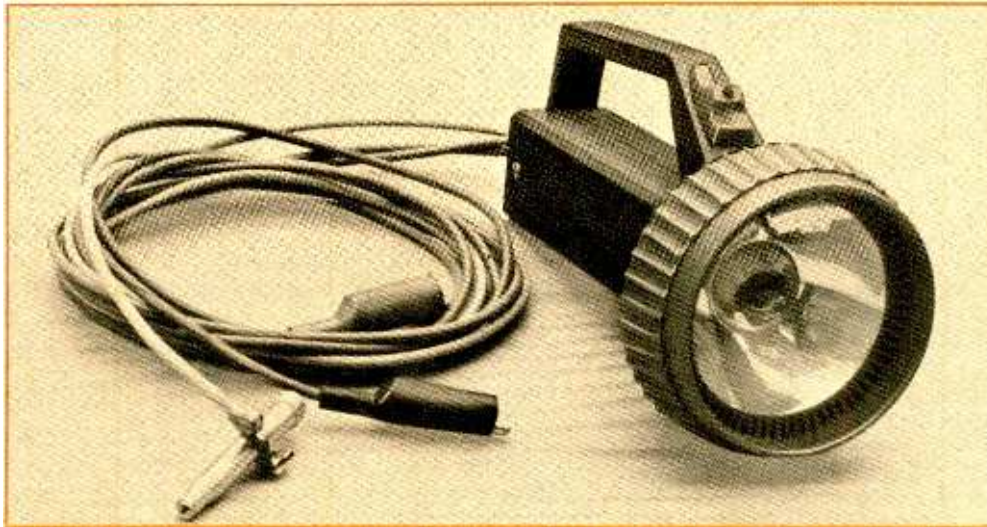

BY ANTHONY CARISTI

**N**OWADAYS, everyone knows how important it is to get the best gas economy possible from an automobile. One of the more important factors that affect economy is engine timing. In addition, proper timing is required on all automobile engines so that exhaust emissions do not exceed allowable limits.

Timing changes for a variety of reasons. As the parts of an engine wear, the timing tends to become retarded. If ignition points are replaced, timing is also disturbed. Furthermore, it is virtually impossible to set the point gap exactly the same as it was when the timing was last set.

Using a dwell meter is a far more accurate method of setting point gap than using a feeler gauge, but even this will not guarantee proper ignition timing. The fact is, the best way to check ignition timing is with a timing light.

The timing light described here can be built for only a few dollars. Yet, it is designed to perform as well as a commercial unit costing \$25 or more. Its light output is bright enough to use

under conditions of bright daylight, and it is battery-powered (from the car's battery) to make it independent of the ac line.

**About the Circuit.** The heart of the timing light's circuit (Fig. 1) is dc-to-dc converter transformer *T1*. It alternately switches current between transistors *Q1* and *Q2*, while stepping up the battery potential to about 125 volts. A ferrite pot core was chosen for this circuit to keep down project size and cost.

The primary winding of *T1* (wound around the pot core) is done by the "bifilar" method that gives tight coupling and accurately locates the center tap. The tight coupling is essential to keeping the voltage spikes across the transistors to an absolute minimum. (In this type of circuit, the spikes can easily exceed ten times the supply voltage if a poorly designed transformer is used causing transistor failure.) By using a bifilar winding for the primary, the voltage spikes across *Q1* and *Q2* are well below the 60-volt rating of the transistors.

The stepped-up voltage from the secondary of *T1* is again stepped up by the voltage-doubler circuit consisting of *D1* and *D2*. It is then passed into flashtube *FT1*.

**Construction.** Perhaps the most demanding part of the construction process is the winding of *T1*. Even so, the job is not difficult, only time-consuming. The transformer should be wound in the following manner:

Start by winding the feedback loop (its leads are labelled 1 through 3 in Fig. 1) on the bobbin supplied with the ferrite core. Use No. 30 enameled wire. This winding consists of 10 turns of wire, interrupted at the 5th turn for a center-tap connection. Connect and solder 5-in. (12.7-cm) lengths of stranded hookup wire to the ends and center-tap of the winding. Label the leads 1 at the first turn, 2 at the center-tap, and 3 at the final turn. Then wrap the winding with a layer of thin Mylar or plastic tape.

Next comes the bifilar-wound primary winding. This consists of 27 double turns of No. 30 enameled wire.

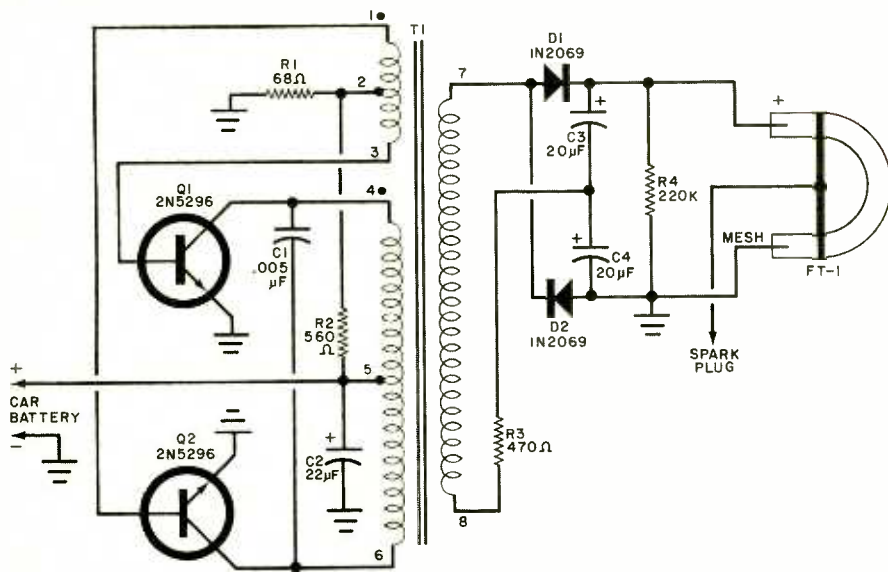

### PARTS LIST

- C1—0.005- $\mu$ F, 500-volt disc capacitor
- C2—22- $\mu$ F, 25-volt tantalum electrolytic capacitor
- C3, C4—20- $\mu$ F, 150-volt electrolytic capacitor
- D1, D2—500-volt, 1/2-ampere silicon rectifier (IN2070, HEP R0053 or equivalent)
- FT1—250-volt, 50-watt-second flash-tube (Radio Shack No. 272-1145 or similar)
- Q1, Q2—60-volt, 1-ampere npn silicon transistor (2N5296 or equivalent)
- R1—68-ohm, 1/4-watt resistor
- R2—560-ohm, 1-watt resistor
- R3—470-ohm, 2-watt resistor
- R4—220,000-ohm, 1/2-watt resistor

T1—Transformer wound on TDK Type H5A P2213 Z52H ferrite core and TDK Type BP 2213-612 hobbin (See text); color-coded test lead cables; alligator or crocodile clips with insulated boots (2); rubber grommet; printed circuit board; Dow Corning Silastic<sup>®</sup> cement; machine hardware; stranded hookup wire; No. 30 and No. 36 enameled wire; spring-type spark plug cable connector (available from most automotive supply outlets); stranded hookup wire; solder; etc.

\*The TDK ferrite-core/hobbin assembly, \$3.50; and an etched and drilled pc board for the timing light, \$1.40 are available from: Anthony Caristi, 69 White Pond Rd., Waldwick, NJ 07463.

Fig. 1. The dc-to-dc converter (T1) steps up the battery voltage.

Label one end of a 4-ft (1.22-m) strand of the enameled wire with a 4. Label one end of a similar strand 5. Starting with these two ends together, wind 27 turns of both wires on the bobbin. Using an ohmmeter, determine the unmarked end of the wire that started with 4 and connect it to the end

marked 5. This is the center tap. The other unmarked end is terminal 6. Cover the winding with tape to hold it in place and insulate it from the secondary.

The secondary winding consists of 240 turns of No. 36 enameled wire. This is the most tedious part of as-

sembly. Be sure to accurately count the number of turns as you go. How many turns you wind will determine the dc potential applied to the flash-tube. When you are finished winding, attach 5-in. lengths of stranded hookup wire to the winding ends and label them 7 and 8. Then wrap the turns with tape.

Now you can begin assembling the circuit proper. A printed circuit board is recommended for component mounting (see Fig. 2 for actual-size etching and drilling guide and components placement diagram).

Transformer T1 is mounted on the board with the aid of a 6-32  $\times$  1-in. machine screw, fiber washer, (at the top of the transformer), and a 6-32 nut. Do not overtighten the hardware or you will crack the core, rendering it useless. (Note: Capacitor C4 mounts on the board atop C3 as shown in Fig. 3)

When the circuit board assembly is completely wired, temporarily connect to the appropriate points on it red and black hookup wires for the positive and negative battery leads. Connect the leads, properly polarized, to a 12-volt battery or other dc source. If the board and transformer are properly assembled, you should hear a high-pitched tone when power is applied. This is the vibration of the transformer core as the circuit oscillates. A VOM connected across R4 should provide a 250-volt reading if the input potential to the circuit is set to 14.5 volts. If the circuit does not oscillate, the phasing of the feedback winding of T1 may be incorrect, in which case, you can transpose leads 1 and 3 and try again. Remove the temporary leads.

The type of flashlight body best suited for your timing light is shown in the lead photo. You will have to drill two mounting holes for the circuit board assembly. A third hole that permits color-coded battery and plug leads to exit the flashlight body should be lined with a rubber grommet. Pass the leads through this hole and connect and solder them to the appropriate points on the board. Terminate the positive and negative battery leads with insulation-booted alligator or crocodile clips and the plug lead with a spring-type plug-to-cable adapter.

Turn over the circuit board and carefully solder a 4-40 machine nut to the copper pads surrounding the mounting holes. Make certain that the nuts are centered over the holes and that no solder flows into the threads.

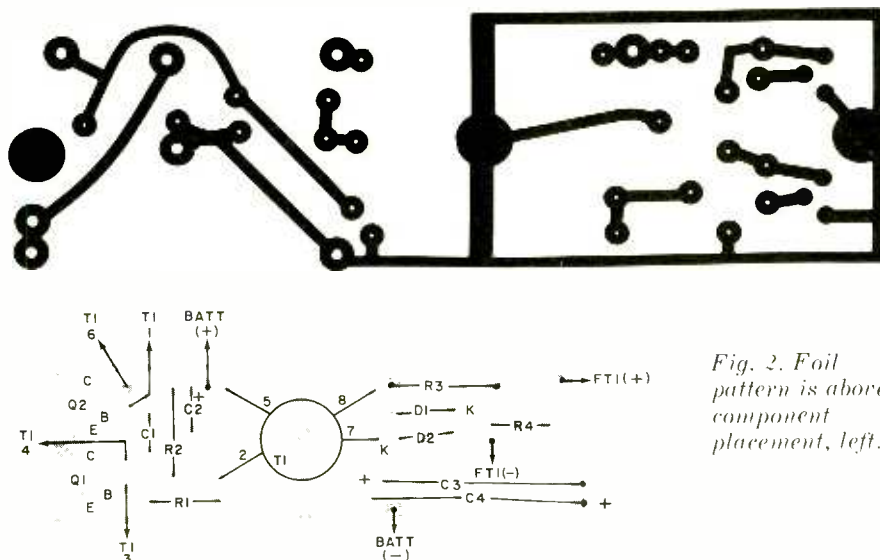

Fig. 2. Foil pattern is above, component placement, left.

The flashtube mounts in the flashlight's reflector. You can enlarge the standard lamp hole in the reflector with a rat-tail file, working carefully to avoid damaging the reflector or scratching its reflective coating. The flashtube's fit should be reasonably close without binding. Place the reflector assembly face down on a flat surface and insert the flashtube in the enlarged hole, positioning it with its point against the glass lens and vertical to the plane of the lens. Run a bead of epoxy or Dow Corning Silastic<sup>®</sup> cement between flashtube and reflector and allow the cement to set overnight. Be sure to maintain the flashtube vertical to the lens as the cement sets (Fig. 4).

Once the cement has set, you can complete final assembly. Locate the negative (woven) electrode lead of the flashtube and connect it to the hole marked FT1(-) in the component-placement guide in Fig. 2. Then connect the positive electrode lead (it exits the end of the flashtube opposite the negative electrode lead) to the FT1(+) point on the board. The only connection left to be made is the spark-plug test lead. Locate this lead and connect and solder it to the high-voltage terminal on the flashtube. (Note: The high-voltage terminal is the metal band affixed to the outside of the flashtube.) Pack the connection with Silastic cement to insulate it and set the assembly aside to harden.

When the cement has set, slide the circuit board assembly into the flashlight case and anchor it in place with



Fig. 3. Wired pc board assembly shows T1 mounted with hardware fiber washer. C4 is on top of C3.

two 4-40 × ½-in. machine screws. Screw on the reflector assembly but under no circumstances permit the reflector itself to rotate. If you allow the reflector to rotate, the flashtube will be damaged or a short circuit will develop.

**How to Use.** Kettering ignitions require that the ignition point dwell time be set to manufacturer's specifications before timing adjustment is made. This can be easily accomplished by using a dwell meter on most General Motors cars and adjusting the points with an Allen wrench while the engine is running. On most other car makes, the dwell angle must be set by adjusting the point gap opening. Bear in mind, however, that the dwell angle must always be properly set *before* the timing is adjusted as changes in the dwell angle will change ignition timing.

Locate the number one cylinder of your car's engine. (On 4- and 6-cylinder engines, it will be the one

nearest the front of the engine. The number-one cylinder on a V8 engine is also nearest the front, but it could be either on the left or the right.) With the engine shut off, remove the ignition lead to the number-one cylinder and connect the timing light's plug lead to the plug. Replace the ignition wire.

Before starting the engine, it is advisable to clean the flywheel and paint a thin white line over the timing mark so that it is readily visible. Then refer to the decal, located in the front of the engine compartment of late model cars, to determine the calibration of the timing scale and proper ignition timing specifications.

Remove the rubber hose connected to the vacuum diaphragm of the distributor and plug the hose opening with a pencil. This disables the automatic vacuum advance built into the distributor. Timing of an engine is always adjusted with the vacuum advance disabled. If you neglect to do this, you will set the timing incorrectly and the engine will not operate properly.

Connect the remaining two timing light cables to the car's battery, observing the proper polarity. Start the engine. The light should now be flashing at a rate of 4 to 5 times per second. Aim the timing light at the flywheel to locate the timing mark. The mark should appear to be stationary. If timing is not correct, loosen the bolt that clamps the distributor assembly to the engine and rotate the distributor in the direction that yields the proper indication. Tighten the bolt and recheck the timing to make sure it has not changed.

Stop the engine. Remove the timing light and replace the hose to the distributor's vacuum-advance diaphragm. The timing of the engine is now correctly set. It need not be checked again until the points are replaced. ♦

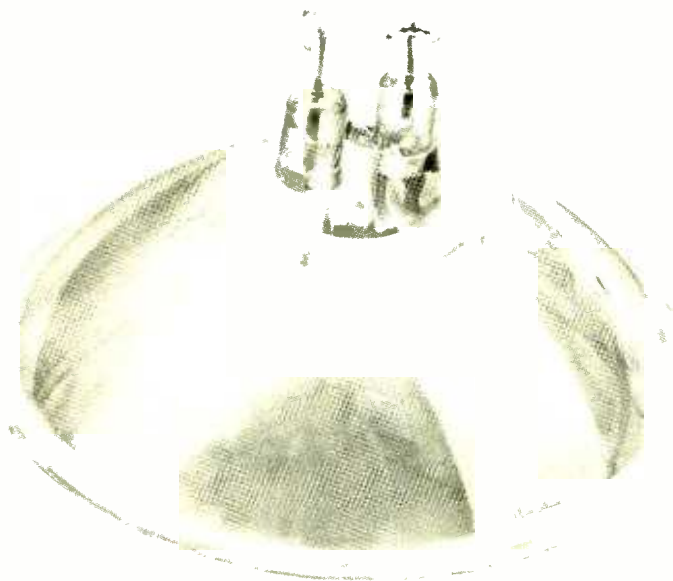

Fig. 4. Flashtube mounts in enlarged hole in light reflector.

**P**HASE-LOCKED loop circuitry has been popularized by its current use in high-quality FM stereo tuners and by publicity accompanying the Dorren Quadraplex system of discrete 4-channel FM (a quadrasonic FM broadcasting contender).

Though the advantages of PLL in FM reception have been used for many years in sophisticated military and space applications, integrated-circuit versions weren't introduced until 1970. Lowered costs have spurred applications in many consumer-electronics areas.

The phase-locked loop is analogous to a servo system—in the FM range. Its behavior as a servo permits it to find and lock on signals, tracking them 6 dB under the noise level. As an electronic filter, it can present a 1% passband to any frequency from 0.1 Hz to the r-f region with excellent stability. Using programmable dividers in its oscillator loop, the PLL becomes a frequency synthesizer that can reproduce practically any frequency from only one crystal. This throws the door open to digital tuning of receivers and transmitters.

These are only a few of the areas where PLL is useful. There are, in addition: frequency shift keying for RTTY, motor control, FM generators, touch-tone telephone, and stereo and four-channel decoding. Now that the price of PLL IC's has dropped below \$5.00, the hobbyist and experimenter can add the PLL to their store of basic building blocks.

**PLL Basics.** The PLL is a feedback system comprised of four basic elements (Fig. 1): a phase detector or comparator; an external low-pass filter; an error correction amplifier; and a voltage controlled oscillator (vco).

The vco is a free-running form of multivibrator whose center frequency is determined by an external timing capacitor and resistor. The vco output is presented to the phase comparator, where it is compared to the incoming signal. The result is an error correction voltage whose magnitude is a function of the phase and frequency differences of the two signals.

This signal is then filtered in an external low-pass filter and amplified in the error correction amplifier. The output of the latter is fed back to the voltage-control input of the vco to complete the loop and cause the oscillator frequency to approach more closely the frequency of the input.

Once the vco starts to change fre-

# HOW PHASE-LOCKED LOOPS WORK

BY HERB COHEN

*Theory and applications of an old circuit, revitalized and refined by IC technology.*

quency, it is in the "capture" state; and it continues to change frequency until its output is exactly the same frequency as the input. The circuit is then "locked" so that the loop frequency varies exactly with the input frequency.

Thus, the loop has three states: free-running, capture, and locked or tracking. The capture state is highly complex. Interestingly, the capture range (frequency band above and below the vco center frequency) is not as wide as the locking range.

A closer look at the capture state will provide an explanation. Figure 2 shows the waveform of the voltage at the output of the error-correction amplifier. As capture starts, a small sine wave appears. This is the "beat" between the vco and the input signal. Note that the negative half of the waveform is slightly larger than the positive half. This is the dc component of the beat, which drives the vco toward lock. Each successive cycle causes the vco to move closer to the input signal.

There are two results of this action which help the vco to lock. First, the closer the vco approaches the input signal, the lower the beat frequency. This allows the low-pass filter to pass more of the beat frequency to the vco with a correspondingly larger portion of the dc component. The vco is now skipping two steps toward lock and one step back. At the same time, the closer the vco nears lock, the longer it wants to stay there, and the more reluctant it is to move away. This extends the negative half of the cycle, reduces the positive half, and increases the dc component to speed up the process. The vco finally locks and the beat frequency is zero.

The low-pass filter is an important factor in controlling the capture range. If the vco is too far away from the signal, the beat frequency will be too high to pass through the filter and the signal is out of the capture band.

Once lock has been achieved, the filter no longer restricts the PLL. It can track a signal well past the capture band, being restricted only by the output range of the phase comparator. However, the filter does limit the speed at which the PLL can track. If the signal frequency changes too rapidly, the PLL can become "unlocked."

The low-pass filter is an engineering trade-off. On one hand, it restricts the capture band and reduces tracking speed; but, without it, the PLL would have great difficulty locking. The filter supplies the PLL with a short-term "memory" of where it was with respect to the signal, providing a sort of fly-wheel effect. It also "memorizes" the rate-of-change of the signal frequency. Even if the signal should drop into a noise level for several cycles, the filter will continue to shift the vco at the same rate until it picks up the signal again. This produces a high noise immunity and locking stability.

**The 560 Family.** The most popular family of PLL IC's is the Signetics 560 series. The table lists the important specifications for various units in the series. The first three are high-frequency devices, with typical vco operation of 15 MHz and a maximum of 30 MHz. Above 15 MHz, its opera-

Fig. 1. Four basic elements of a phase-locked loop.

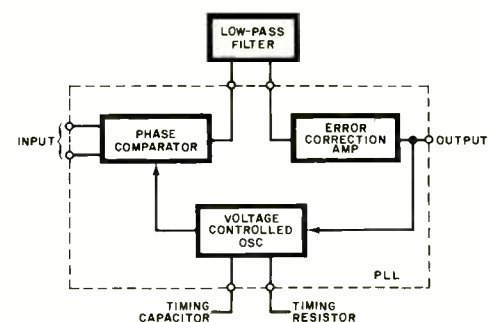



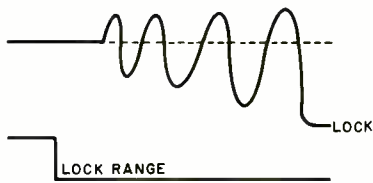

Fig. 2. Upper trace shows beat between vco and input. Lower trace is the lock range.

tion becomes critical, and great care is needed to get them to perform properly. Its input sensitivity is very good—the device can lock on to signals of 100 to 200 microvolts. The 561 is a duplicate of the 560, but it has an added product detector for synchronous demodulation. The 565 has an exceptional lock range (typically  $\pm 60\%$ ); however, its input sensitivity is only fair (1 millivolt for lock). The 565 has one added advantage over the high-frequency units: its vco is tuned with an RC network, and frequency is directly proportional to the change in the resistance. This permits tuning over a 10-to-1 frequency range using a potentiometer.

The 567 is primarily a narrow-band filter. Its interesting feature is a built-in synchronous switch which turns on when the unit goes into lock. The switch is able to handle up to 100 mA and can be used to turn on an SCR, a relay, or a lamp for indication of the lock condition. Another feature of the 567 is its low power-supply voltage (4 volts minimum), making it ideal for battery operation. However, it is less input-sensitive than the others in the series.

**Working with the 565.** The 565 PLL is the only member of its family that is not internally stabilized with a zener diode. Therefore, a well-regulated supply or a zener diode should be used to keep the power stable.

Suppose you want to use a 565 as an SCA background music decoder. A suggested circuit is shown in Fig. 3.

The SCA signal is 14-kHz FM on a 67-kHz subcarrier. Note that a single-ended power supply is used and the resistor network made up of  $R_3$  through  $R_6$  is used to bias the inputs at 3.2 volts. Thus only one comparator input (pin 2) is used for the signal.

The two input capacitors ( $C_2$  and  $C_3$ ) and resistor  $R_2$  act as a high-pass filter to remove the lower-frequency stereo subcarrier from the SCA input. Capacitor  $C_1$  and resistor  $R_1$  determine the operating frequency of the internal vco by the expression  $1.2/(4R_1C_1)$ . Since we know that the vco should operate at the SCA frequency of 67 kHz, and we would like  $R_1$  to be about 5000 ohms, we can

The demodulated output (pin 7) is passed through a three-stage low-pass filter ( $C_5$  to  $C_7$  and  $R_7$  to  $R_9$ ) to provide the necessary de-emphasis and attenuate the high-frequency noise that often accompanies the SCA transmission. The demodulated output signal is approximately 50 mV and the frequency response extends to 7 kHz.

The locking range is determined from  $\pm 8F_o/V_{cc}$ , which comes out ( $\pm 8 \times 67$ )/10 or  $\pm 53.6$  kHz. Since the bandwidth of the SCA subcarrier is only 14 kHz, there is more than enough locking range available. This expression applies only when the input signal is high enough to saturate the com-

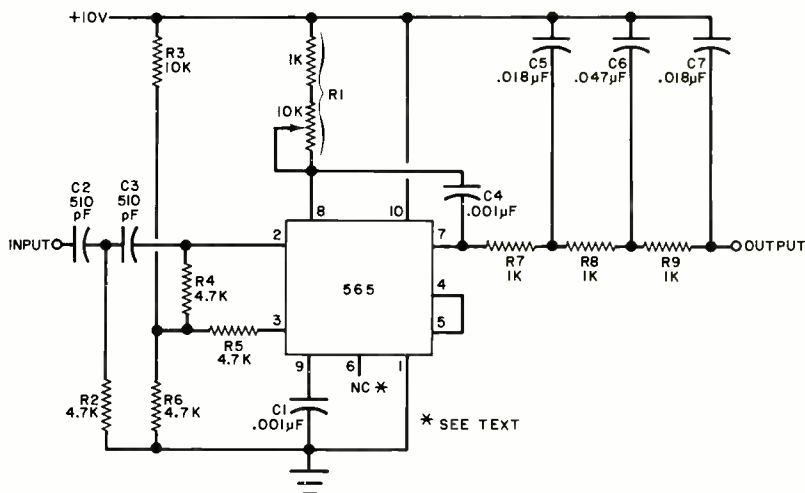

Fig. 3. Typical phase-locked circuit for decoding SCA background music on FM broadcast.

calculate the value of  $C_1$  needed. This works out to be 0.000895 or 0.001  $\mu\text{F}$ .

Tuning resistor  $R_1$  is made up from a 1000-ohm fixed resistor in series with a 10,000-ohm potentiometer. (Remember that we assumed a value of 5000 ohms for  $R_1$ .) Using this larger potentiometer will enable tuning over a wide range around the center frequency (in case the tolerance of  $C_1$  is very broad), while the 1000-ohm fixed resistor will act as a current limiter if the potentiometer resistance is reduced to zero.

If the input signal decreases, the correction voltage also decreases, thereby reducing the locking and capture ranges.

The curve in Fig. 4 shows the locking range versus the input signal level. Since the SCA decoder requires a 20% locking range, the curve shows that a 10-mV input will be enough to drive the phase lock.

The 565 provides a method of limiting the locking range. A tap on an internal voltage divider is used as a reference output (pin 6). This voltage is the same as the output voltage (pin 7) when  $F_o$  is equal to the incoming signal. Connecting a resistor between pins 6 and 7 differentially loads the output without changing the dc level or shifting the vco. A resistance change from 25,000 ohms to zero between these points will shift the locking range from  $\pm 60\%$  to  $\pm 20\%$ . Since the output is loaded, one can expect a corresponding decrease in the level of the output signal.

### PLL SPECIFICATIONS

Type	Min. Input For Lock	VCO Freq. (MHz)	Lock Range	$V_{cc}$	
				Min.	Max.
560	120 $\mu\text{V}$	15	15%	16	26
561	120 $\mu\text{V}$	15	15%	16	26
562	200 $\mu\text{V}$	15	15%	16	30
565	1 mV	0.5	60%	10	26
567	20 mV	0.1	12%	4	10

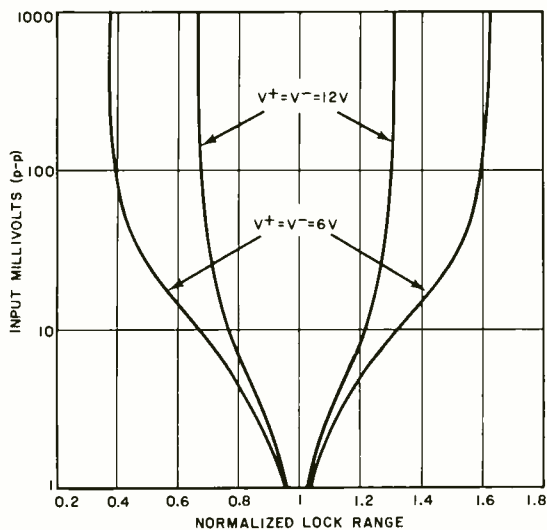

Fig. 4. Lock range versus input signal level for the 565 phase-locked loop.

### HISTORY OF PHASE-LOCKED LOOPS

In 1932, a group of British physicists was working on a new method of radio reception to compete with the superheterodyne system. This new approach would require only one tuned circuit and would have greater fidelity and selectivity than the superhet circuit.

The theory was deceptively simple. When an r-f oscillator and an incoming signal are mixed at the same phase and frequency, the output product will be a perfect audio reproduction of the transmitted modulation. An adjacent carrier, 20 kHz away, will be demodulated as a 20-kHz signal and could easily be filtered out of the desired audio.

The system was constructed using a simple untuned r-f amplifier to feed the mixer. The results were astonishing—perfect reception with no adjacent-channel interference. The only problem was that the local oscillator would slowly drift off frequency, producing a beat note which made reception intolerable.

One member of the group then theorized that if the oscillator frequency could be compared to the signal frequency in a phase-detector circuit, a correction voltage could be produced to return the oscillator. This could be done by having the correction voltage drive a Miller-effect (electronic variable capacitance) amplifier connected across the tuning circuit of the oscillator. The same feedback idea had worked in servo systems. So, why not an electronic servo?

The new oscillator circuit was built and connected to the receiver system. It not only stayed in frequency with the incoming signal, it locked itself in. When the tuning was changed to a new

signal, the oscillator would hold onto the old until the new one got too strong and then it would switch to the new signal. When the system was tuned between carriers, it hunted for the stronger one and locked on to it.

The receiving system, which originally had been named the homodyne circuit, was renamed the syncrodyne circuit.

The circuit, though superior to the superhet in many ways, could not compete where cost was concerned. The oscillator locking circuitry was too expensive. Though the syncrodyne receiver circuit was never used in AM receivers, it attracted the attention of FM receiver designers who were looking for a method of stabilizing the mixer/oscillator at 100 MHz. The FM receiver already had a form of phase discriminator to demodulate the i-f signal. By connecting the dc component of the discriminator output to a Miller-effect tube across the local oscillator, the latter could be forced to lock in 10.7 MHz above the incoming signal to produce an exact 10.7-MHz i-f. The system was called automatic frequency control.

The budding TV-receiver industry, looking for a way of locking the horizontal oscillator, developed several phase-locked circuits—notably the "Syncro-Guide" and "Syncro-Lock."

By the mid 1940's, phase-lock was being used in military microwave and radar receivers. When NASA fired the first space capsule, its 10-milliwatt, 108-MHz transmitter signals were received by a phase-locked receiver, whose ability to follow a signal below the noise level was considered phenomenal.

The differential output (pins 6 and 7) is useful in frequency-shift keying. This is a method of reproducing digital pulses by shifting the frequency of the input signal, generally 1 kHz for a zero state and 2 kHz for a one state. By connecting a voltage comparator across pins 6 and 7, the output pulses are cleaned and shaped. They can then be interfaced with the following digital circuitry.

The 565 has two outputs that can be useful in some applications. A triangle waveform is available at pin 9 with an output of 2.4 V and 0.5% linearity. Because even light loading at the output will distort the triangle wave, a high-impedance buffer is recommended when using it.

Note that there is a short between pins 4 and 5. Pin 5 is the output of the vco while pin 4 is the input to the comparator. In the SCA adapter, these two pins are not used. The output at pin 5 is a square wave with an impedance of 5000 ohms and a level of 5.4 V p-p.

As shown in Fig. 5, pins 4 and 5 provide a convenient way to insert a programmable frequency divider for frequency synthesis. If the input,  $F_{REF}$ , is a

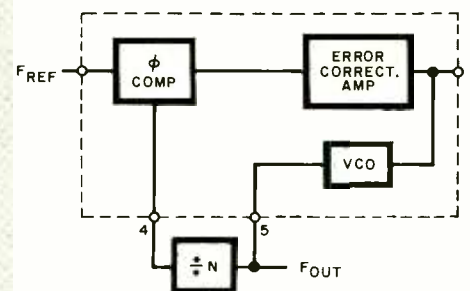

Fig. 5. Adding a divider permits frequency synthesis.

10-kHz crystal-controlled source, and the divider is programmable from 1 to 10, the vco output,  $F_{OUT}$ , is 10 to 100 kHz in steps of 10 kHz, all having the same stability as the crystal. If a divider is programmed from 100 to 110, the vco becomes programmable from 1 MHz to 1.1 MHz in 10-kHz steps. Unfortunately, the 565 can only operate to 1 MHz, so this discussion serves only to illustrate how you can use a phase-locked loop and a programmable counter to synthesize almost any desired frequency.

This, in essence, is how frequency-synthesized CB and FM devices work. If you have a synthesized local oscillator, you can receive almost any channel on any band, provided they are evenly spaced. ♦

# FREE!

## HEATHKIT® CATALOG



The world's largest catalog of easy-to-build, money-saving electronic kits — now featuring our entire line of exciting new Heathkit personal and hobby computer systems!

- Self-Instructional Electronics Courses
- Experimenter Breadboard
- High-Performance Frequency Counters
- VTVM's, VOM's and Oscilloscopes
- Color TV and Hi-Fi Components
- Electronic Clocks and Weather Instruments
- Amateur Radio Equipment
- Nearly 400 kits for the Electronic Hobbyist

Every Heathkit product comes with a fully-illustrated, step-by-step instruction manual that tells you everything you need to know to make kitbuilding fun and easy. Thousands of people have discovered the satisfaction—and savings—of handcrafting a fine piece of electronics equipment. You can build it better — let us show you how!

**Send for your FREE Catalog today!**

Heath Company, Dept. 110-340  
Benton Harbor, Michigan 49022

FREE	HEATH Schlumberger	Heath Company, Dept. 110-340 Benton Harbor, Michigan 49022
	Please rush me my FREE Heathkit Catalog. I am not on your mailing list.	
	NAME _____	
	ADDRESS _____	
	CITY _____ STATE _____	
	CL-636A _____ ZIP _____	

**F**OR THE person who likes a challenge, the spirit of friendly competition, and tinkering in electronics, here is a new electronic game to build. It's called "Tug-of-War."

When the **START** button is pressed, the middle light in a chain of nine **LED's** lights up. At approximately five-second intervals, a **GO LED** blinks on for a moment. Each player has a pushbutton which he operates to try to "pull" the illuminated **LED** over to his side. This is accomplished by being the first one to push the **PLAYER** button after the **GO** light comes on. However, there is a catch. If a player pushes his button before the **GO** light, the lit **LED** will advance one position toward the opponent's end.

BY ROBERT C. FROSTHOLM AND ROGER LUNDEGARD  
Signetics Corp.

# || TUG-OF-WAR ||

When one player succeeds in advancing the lit **LED** all the way to his end, the **WINNER** light comes on and the game is over. A new game can be started by pushing the **START** button. You can also add a circuit and speaker to give an audible signal indicating who won the game.

**Circuit Operation.** The project uses a total of 10 timing circuits (built around three dual 555 timers), an up-down counter, and some logic gates.

As shown in Fig. 1, **IC1A** is a clock oscillator that generates a pulse approximately every five seconds. The timing is determined by **R1**, **R2**, and **C1**. During the short period of time

Built around  
popular 555 timer  
devices, this electronic  
game project will  
challenge your  
reflexes.

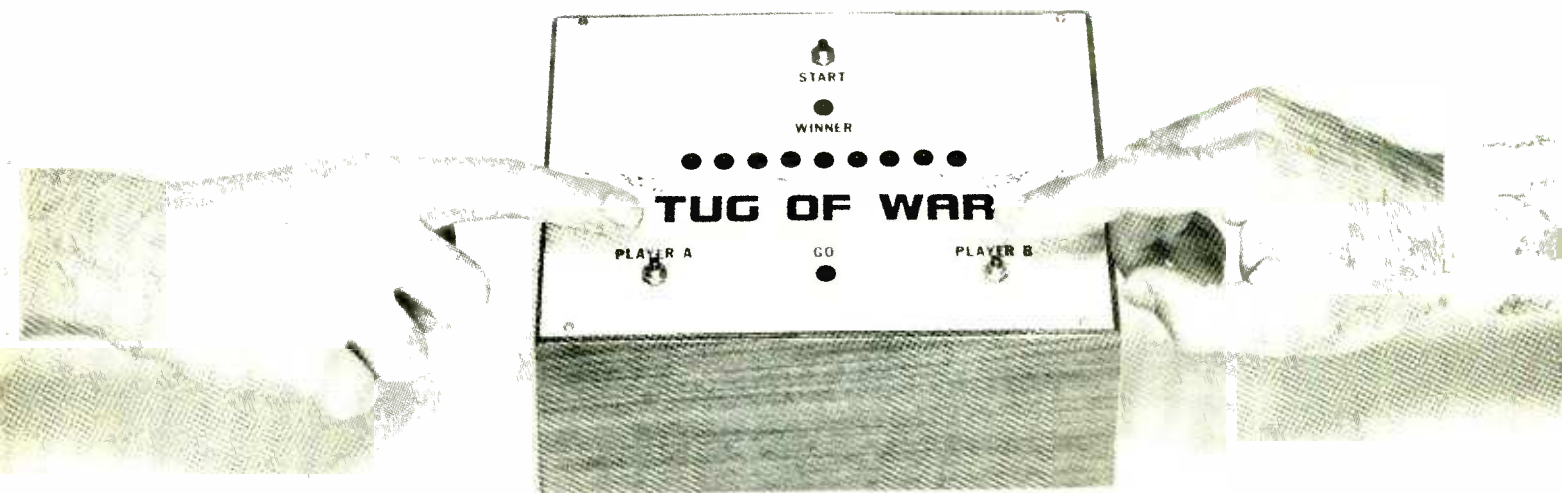

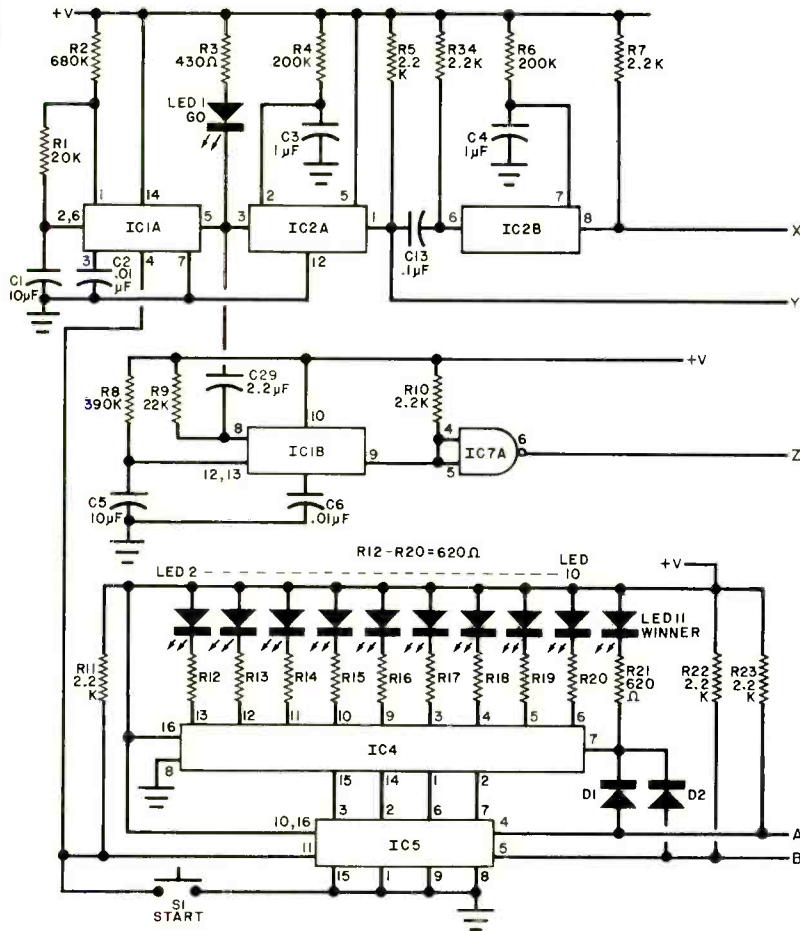

Fig. 1. Clock oscillator IC1A drives IC2A and IC2B to generate two successive gate intervals. Output of IC1B is 4.3-s pulse, inverted to a 0.7-s pulse by IC7A. Up/down counter (IC5) and BCD-to-decimal circuit (IC4) drive LED's.

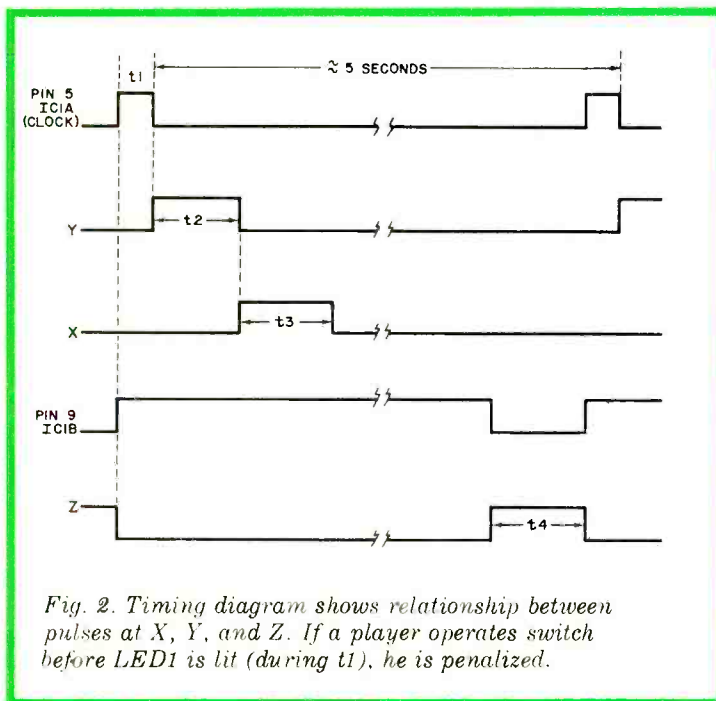

Fig. 2. Timing diagram shows relationship between pulses at X, Y, and Z. If a player operates switch before LED1 is lit (during t1), he is penalized.

## PARTS LIST

- C1, C5—10- $\mu$ F electrolytic capacitor  
 C2, C6, C17, C19 to C23—0.01- $\mu$ F capacitor  
 C3, C4, C8, C11—1- $\mu$ F electrolytic capacitor  
 C7, C10, C13, C14, C15, C16, C27, C28—0.1- $\mu$ F capacitor  
 C9, C12—0.001- $\mu$ F capacitor  
 C18—Not used.  
 C24, C25, C26—47- $\mu$ F, 15-volt electrolytic capacitor  
 C29—2.2- $\mu$ F electrolytic capacitor  
 C30—500-1000 $\mu$ F, 15-volt electrolytic capacitor  
 D1 to D8—1N914 diode  
 D9 to D12—1N2071 diode  
 IC1, IC8, IC9—556A dual timer (Signetics)  
 IC2—558B quadruple timer (Signetics)  
 IC3, IC7—7400 quadruple NAND  
 IC4—8251B BCD-to-decimal (Signetics)  
 IC5—74192 up/down counter  
 IC6—8241A quadruple exclusive OR (Signetics)  
 IC10—LM309DB 5-volt regulator (Signetics)  
 LED1, LED11—Green MV5253 (Monsanto) or similar  
 LED2 to LED10—Red MV5053 (Monsanto) or similar  
 R1—20,000-ohm, 1/4-watt 10% resistor  
 R2—680,000-ohm, 1/4-watt 10% resistor  
 R3—430-ohm, 1/4-watt, 10% resistor  
 R4, R6—200,000-ohm, 1/4-watt 10% resistor  
 R5, R7, R10, R11, R22, R23, R27, R32, R34—2200-ohm, 1/4-watt 10% resistor  
 R8—390,000-ohm, 1/4-watt 10% resistor  
 R9, R25, R30—22,000-ohm, 1/4-watt 10% resistor  
 R12 to R21—620-ohm, 1/4-watt 10% resistor  
 R24, R29—2700-ohm, 1/4-watt 10% resistor  
 R26, R31, R38, R40—2000-ohm, 1/4-watt 10% resistor  
 R28, R33—510-ohm, 1/4-watt 10% resistor  
 R35, R36—130,000-ohm, 1/4-watt 10% resistor  
 R37—75,000-ohm, 1/4-watt 10% resistor  
 R39—120,000-ohm, 1/4-watt 10% resistor  
 S1, S2, S3—Spst temporary-contact pushbutton switch  
 Spkr—8-ohm speaker  
 T1—6.3-volt filament transformer (Triad F-14X or similar)  
 Misc.—Suitable Cabinet, line cord, rubber grommets (11), press-type, mounting hardware, IC sockets (9), clip-on heat sink for IC10, solder, wire, etc.
- Note—The following are available from Four Seasons Corporation, P.O. Box 24, Los Altos, CA 94022: IC package (TW 204) containing IC1 through IC10 for \$19.75; etched and drilled pc board (TW202) for \$12.95; walnut case with metal top plate screened and drilled (TW206) for \$16.95. California residents add sales tax. All prices include shipping in U.S. only.

that this oscillator "sinks" current, LED1 is turned on. The pulse also triggers IC2A and IC1B. The former is a one-shot multivibrator whose "on" time is determined by R4 and C3. Since this timer is edge-triggered and the state of the trigger has no effect on the output pulse, IC2A can be coupled to IC2B to provide a second pulse of equal duration (determined by R6 and C4). The outputs at points X and Y are sequential pulses of equal duration.

When IC1B is triggered, it produces a one-shot output pulse of about 4.3 seconds, determined by R8 and C5. This pulse is inverted by IC7A to produce a pulse of about 0.7 second duration just prior to each clock pulse. The pulse at point Z is used to penalize the player who attempts to anticipate the clock and jumps the gun. The timing diagram in Fig. 2 shows the sequence of events.

The circuitry for the players is shown in Fig. 3. The two circuits are identical except that their outputs are reversed to enable one to drive an up/down counter (IC5 in Fig. 1) in one direction and vice versa. The players' positions are keyed around one-shots (IC2C and IC2D).

To see how the circuits work, assume player B does not touch his button when the GO light comes on or that player A is very fast and is able to press his button during time period t2 (Fig. 2). Then the pulse generated by IC2C is applied to an AND gate with the pulse from point Y. Two exclusive OR gates (IC6A and IC6B) act as a frequency doubler and provide two pulses at point A, which are applied to pin 4 of IC5. This causes IC5 to count down two steps. The BCD-to-decimal decoder (IC4) takes the output of IC5 and causes the lit LED to move two positions toward the A end.

If player A is not quite as fast and pushes his button during period t3, the output of IC2C and the pulse at

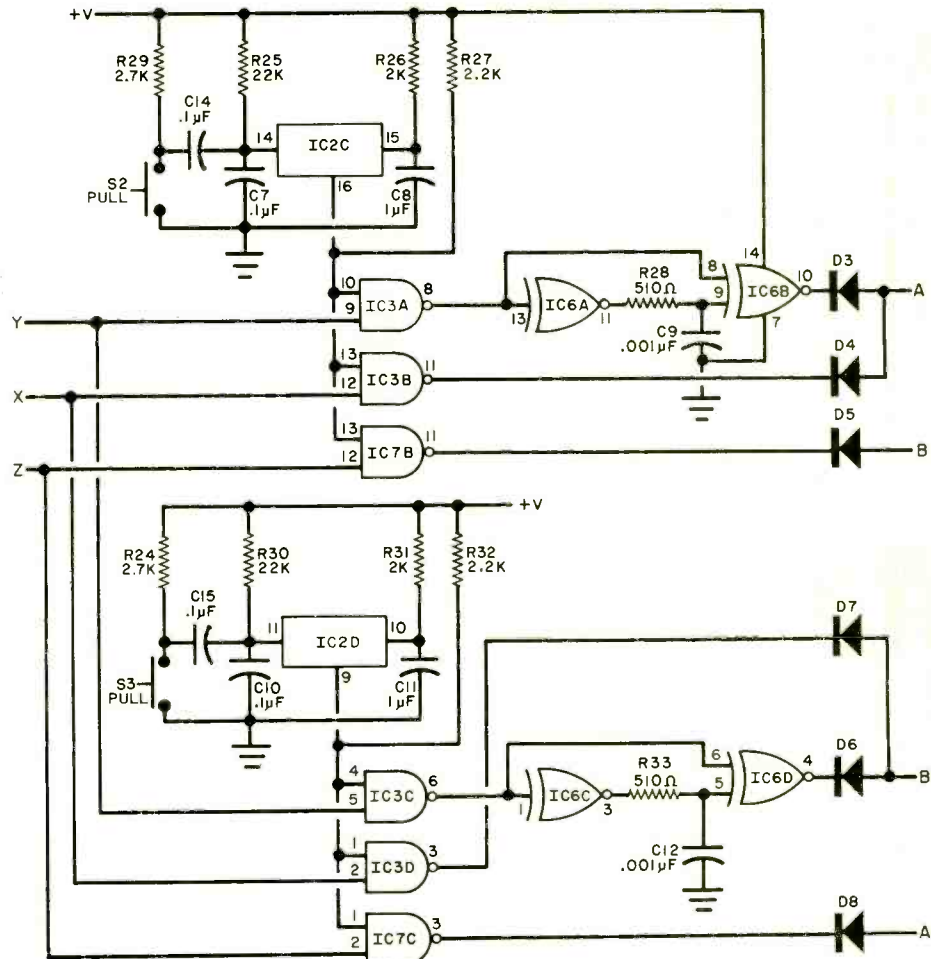

Fig. 3. Player circuits are identical. Outputs of one-shot circuits are compared with timing pulses on X, Y and Z.

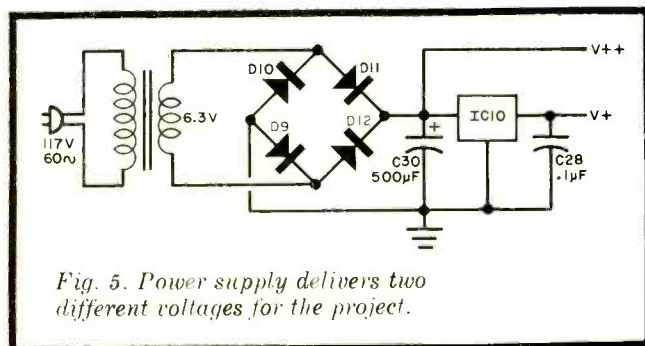

Fig. 5. Power supply delivers two different voltages for the project.

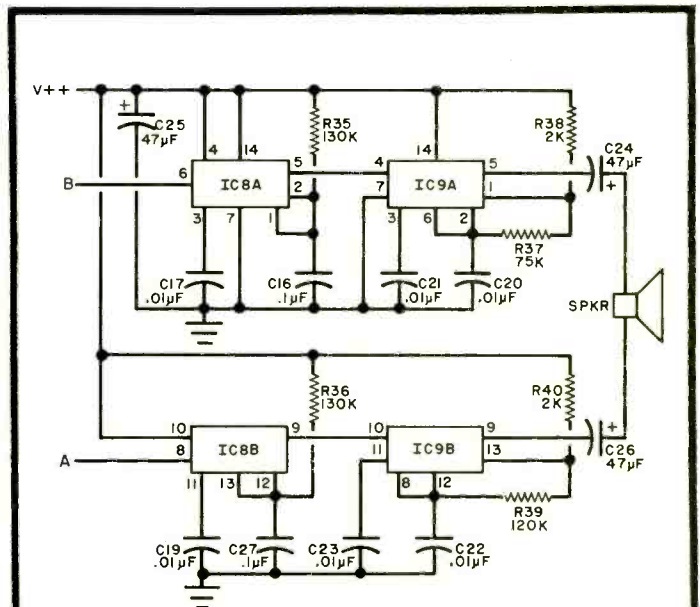
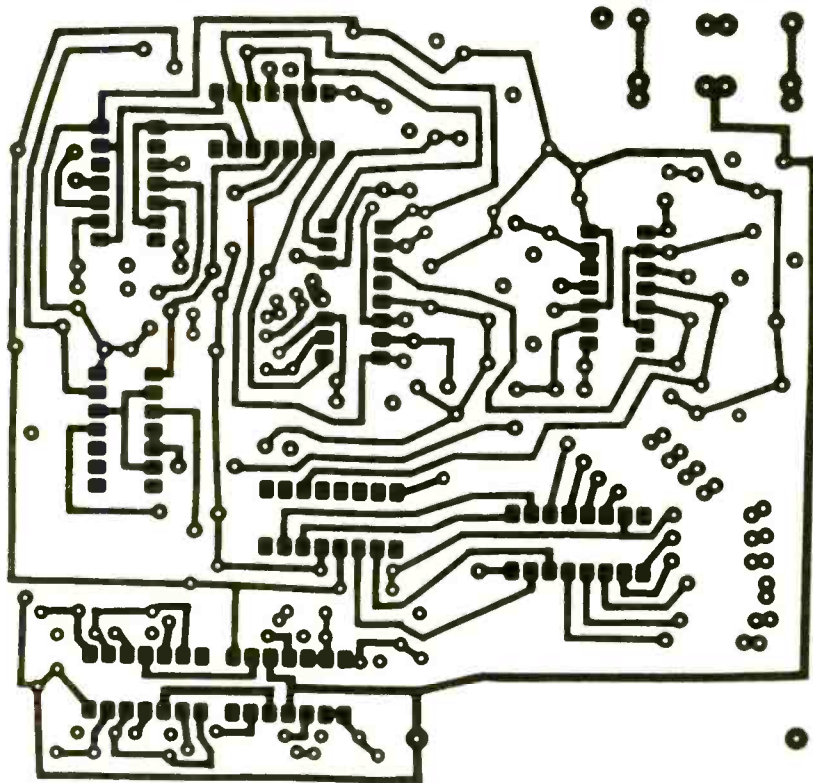
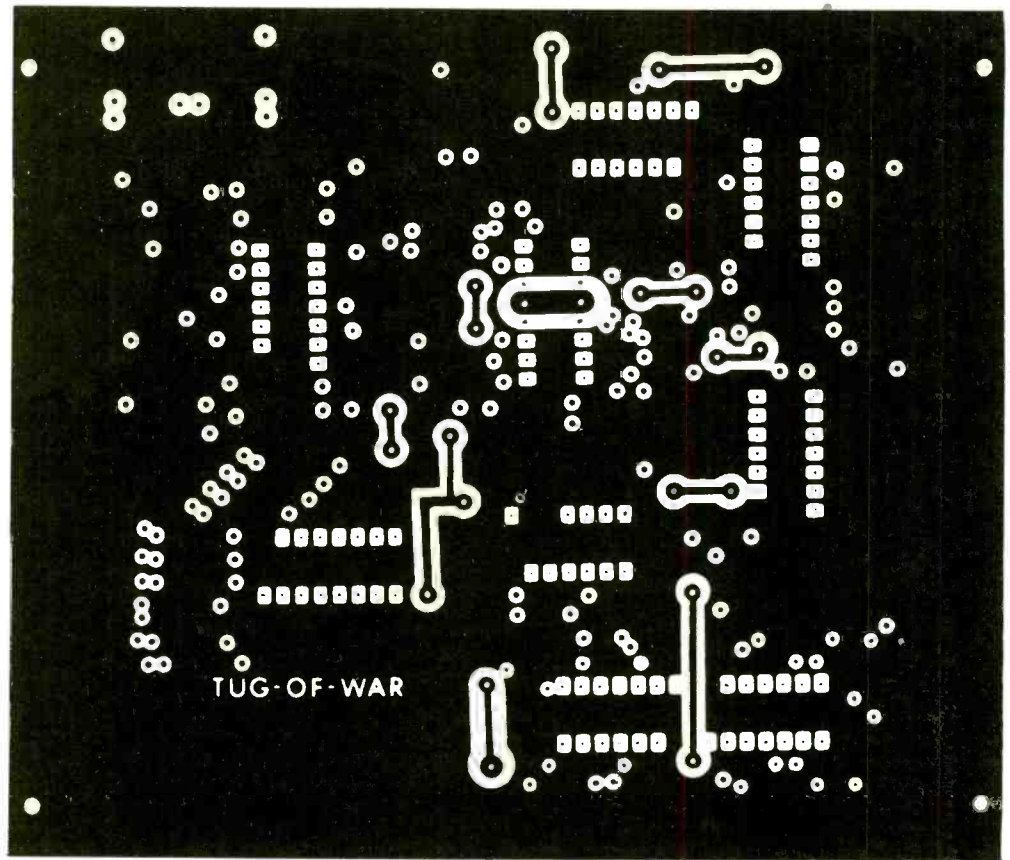

Fig. 4. Optional sound-output circuit is two gated tone-burst generators, each having a different frequency to create separate sounds for players.

Fig. 6. Foil patterns for the double-sided pc board are shown at right and below.



point X are applied to AND gate *IC3B*. Then only one pulse appears at point A, and the lit LED advances only one position toward A.

When player A tries to anticipate the GO light and presses his button too

soon, the pulses from *IC2C* and point Z are applied to AND gate *IC7B* and the output at point B causes the counter to go in the other direction.

The circuit for player B operates in the same way as that for player A. If

both players press their buttons at the same time, the signals cancel each other. After playing the game for some time, the players' reflexes will appear to have improved to the point where the game becomes a standoff. In this event, reduce the values of *R4* and *R6* to shorten  $t_2$  and  $t_3$ . Resistors *R26* and *R31* should be reduced by the same percentage as *R4* and *R6* to reduce the possibility of confusion in the AND gates, since the pulses at X and Y will be much shorter.

When one player has moved the lit LED to his end, *LED11* is lit and diodes *D1* and *D2* prevent any further action until the START button is operated.

The game can be made more exciting by adding a circuit to provide an audible indication of which player has won. The circuit is shown in Fig. 4. Tone bursts are generated by *IC8* and *IC9*. Each half of *IC8* acts as a one-shot which determines how long the associated half of *IC9* is activated. The two halves of *IC9* are oscillators with outputs of different frequencies. When a player wins a game, the signal at A or B causes the appropriate circuit to provide a sound through the loudspeaker.

The simple power supply shown in Fig. 5 can be used for the Tug-of-War.

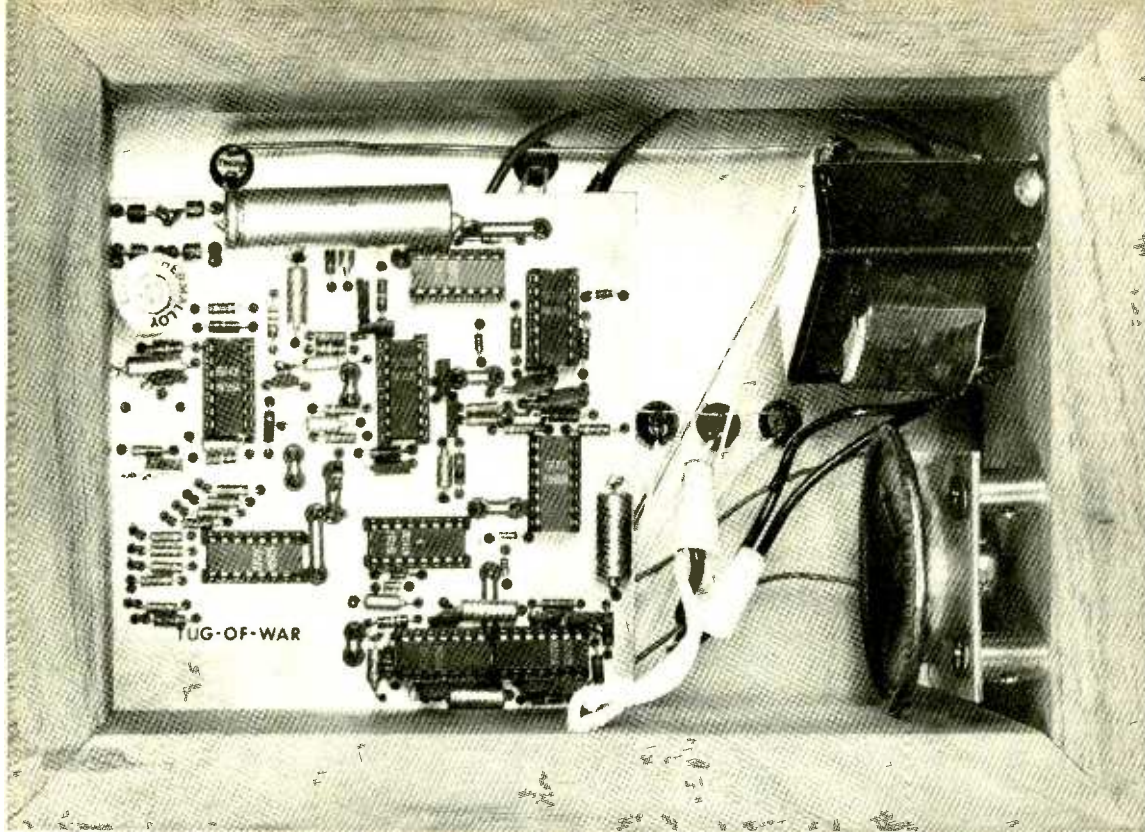

Photograph of interior of the Tug-Of-War shows mounting of printed circuit board with power supply transformer and optional speaker for sound at right.

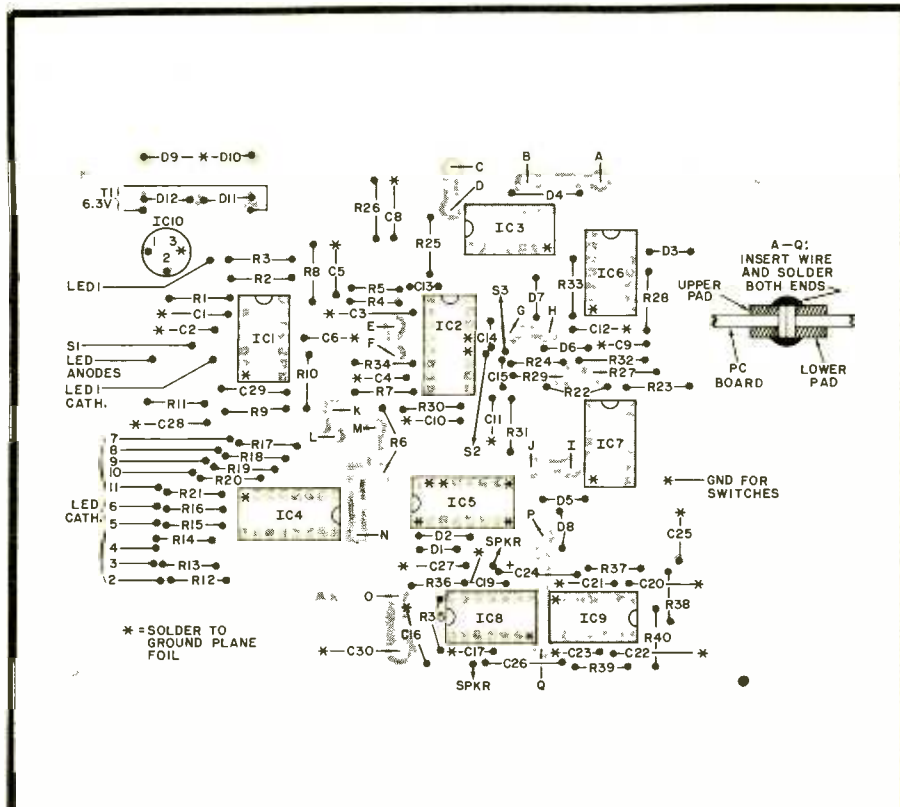

Fig. 7. Components must be mounted carefully since the top of the pc board is primarily a ground plane. Some connections, however, are made to the top side of board (asterisk).

**Construction.** A double-sided pc board such as that shown in Fig. 6 can be used for the Tug-of-War. Don't use sockets for the IC's. Since the top of the pc board is primarily a ground plane, it is important to remember that components must be carefully mounted so that their leads do not touch the ground, though some components and IC pins are soldered on the top side of the board to provide a ground. These points are indicated in Fig. 7 with an asterisk.

Since the board does not have plated-through holes, coincident pads (A-Q) on both sides should be interconnected by small lengths of wire through the holes and soldered on both sides. Use a clip-on heat sink for integrated circuit IC10.

The LED's and switches are mounted on the top cover as shown in the photograph. All use 1/4" holes with grommets for the LED's. Short lengths of insulated wire are used to connect the LED's and switches to the board.

Mount the LED's so that proper positioning and polarity are observed—with LED6 at the center of the line, LED2 toward player A end, and LED10 at the other end. Green LED's are used for the WINNER and GO indicators, while the others are red.



# TWO SINGLE-IC AM RECEIVER PROJECTS

## 1 THE SIMPLEST AM/WWV RECEIVER

BY CARL C. DRUMELIER

**B**ELIEVE it or not, there really is a receiver small enough to fit into your ear. At least the vital components—active elements, r-f amplifiers, detector, and agc—are small enough. All of these components are in the ZN414 linear integrated circuit.

With the ZN414 and only eight out-board components, including battery and power switch, you can make an AM BCB receiver that will perform at a level distinctly out of the toy or novelty class. Alternatively, by adding a few more components, you can use the same chip to tune in the WWV or CHU time-signal stations. In fact, there are dozens of specialized radio applications in which this new IC can be used.

**Simplest AM Receiver.** Perhaps the simplest application for the ZN414 is the AM receiver shown schematically in Fig. 1. With a circuit as simple as this, it is almost impossible for anything to go wrong. In fact, a prototype receiver worked beautifully the first crack out of the barrel. Local stations came in with superb clarity and adequate volume through the headphone.

Because of the outstanding action of the IC's built-in agc circuit, tuning the receiver was a bit unusual. You expect to hear a jumble of stations. But when you tune to the frequency of any one station, the station's carrier affects the agc so to-

tal sensitivity drops enough to eliminate off-frequency stations.

**Time-Signal Receiver.** With only a few more parts than needed for the AM receiver, you can build a 2.5-MHz time-signal-only receiver to pick up WWV. The schematic for the receiver is shown in Fig. 2. With this circuit, a 15-ft length of wire serving as the antenna provided good reception of the WWV signal.

Coils *L2* and *L4* are standard 30- $\mu$ H units with adjustable ferrite cores. For *L2*, the coil must be tapped 10 turns from the bottom to provide a tie-on point for *L3*. Coils *L1* and *L3* each consist of 10 turns of insulated wire wound around *L2* and *L4*, respectively.

When building the receiver, there are

a few points that must be kept in mind. Any device with a power gain of 110 dB requires careful layout of the components to prevent feedback. Hence, keep the tuning assembly (including *L1* through *L4*) isolated from the other components in the circuit. In the circuits in Figs. 1 and 2, the agc action in the IC is highly dependent on the resistance of the headphones; so, use phones with impedances of 400 to 600 ohms.

When tuning the time-signal-only receiver, the variable capacitors are used for coarse adjustments, while the slugs in *L2* and *L4* are used for fine tuning. Adjust them for the strongest, clearest reception of the WWV signal.

**Making A Good Thing Better.** You

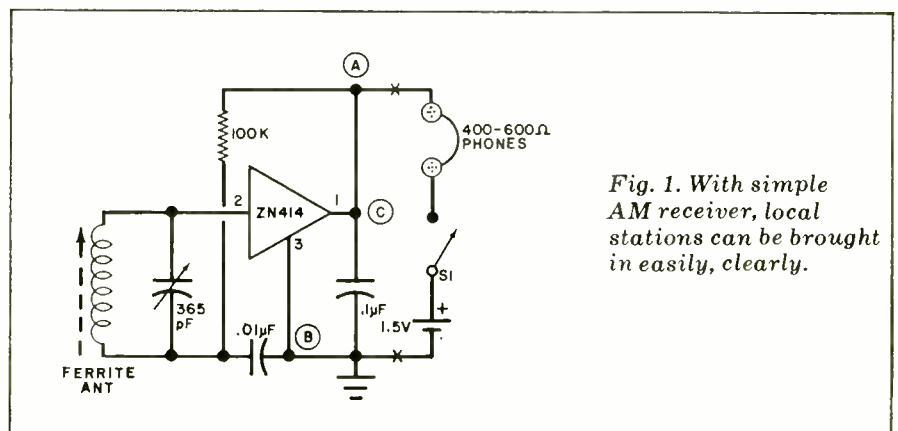

Fig. 1. With simple AM receiver, local stations can be brought in easily, clearly.

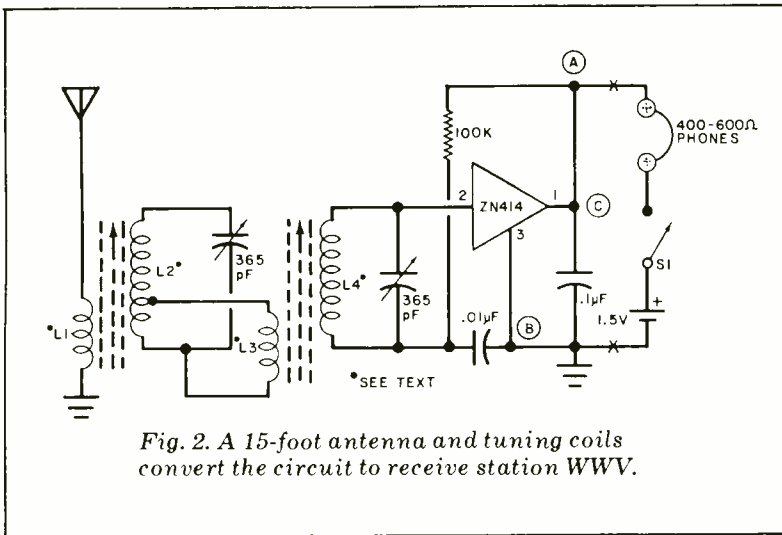

Fig. 2. A 15-foot antenna and tuning coils convert the circuit to receive station WWV.

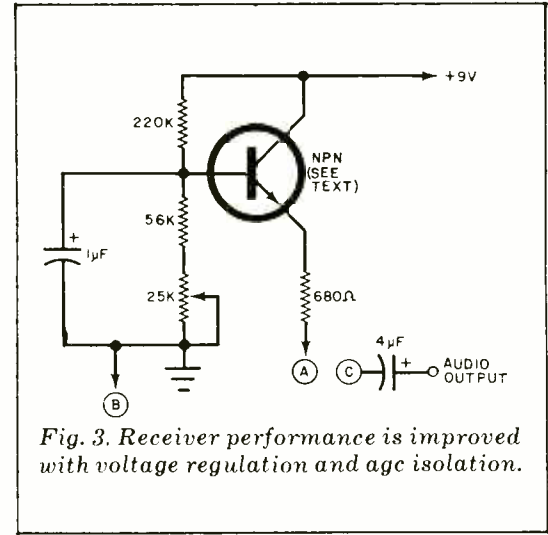

Fig. 3. Receiver performance is improved with voltage regulation and agc isolation.

can improve the performance of the receivers with two simple modifications. The first is the use of a voltage-regulator circuit that permits the receivers to operate safely from a 9-volt transistor battery. The second isolates the IC's agc circuit from dependency on the impedance of the phones or an amplifier into which the receiver's signal is fed. Both modifications are shown in Fig. 3. The lettered points connect to the same points in Figs. 1 and 2. The "X" marks in the receiver schematics indicate that, with the modifications in place, the phones, power switches, and battery must be disconnected.

Just about any silicon transistor (npn variety) can be used in the voltage-regulator circuit in Fig. 3. Use the potentiometer to adjust the voltage between pins 1 and 3 of the ZN414 to roughly 1.3 volts (the level recommended by Ferranti). If you wish, once the pot has been set to provide the proper voltage, you can remove it from the circuit and replace it with an appropriate-value resistor.

**More ideas.** By letting your imagination run free, you can visualize many other applications for the ZN414. For example, how about using the IC as a fixed-tuned i-f amplifier on 1.75 MHz and

precede it with a simple 2-to-54-MHz converter for shortwave listening? Or how about deliberately introducing some r-f feedback that would allow the IC to oscillate for demodulating SSB transmissions? You might even try replacing the LC resonant circuit ahead of the IC with a series-resonant crystal to obtain selectivity suitable for CW reception.

You can see that the ZN414 IC is one of the most unique and versatile building blocks offered to the experimenter in recent years. We predict that readers will find dozens of interesting applications for this versatile device once they become acquainted with it. ◇

## ABOUT THE ZN414

Imagine an IC that has a very high input impedance, three r-f amplifiers, and transistor detector stage—all in one tiny TO-18 package with only three leads. (See illustration.) What we have just described is a versatile linear IC called the ZN414, made by Ferranti Electronic Components Division in Britain. Now available in the U.S., this IC offers the hobbyist and experimenter a new approach to radio experimentation.

The ZN414 is housed in just about the smallest package you are likely to see for transistors, let alone IC's. Its three-lead format makes the device a cinch to work with. Those three leads are for the input, output, and a ground that is common to both. Although the circuit configuration is unknown to us, we do know that it contains 10 transistors.

A list of its technical specifications reveals just how versatile is the ZN414. The circuit is designed to amplify incoming signals ranging in frequency from 150 kHz to 3 MHz. Its detector responds to AM signals within that range. The IC has a remarkable

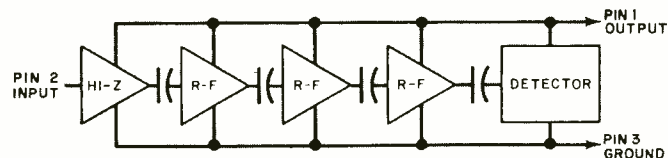

degree of automatic gain control (agc). And the best is yet to come: the ZN414 can deliver a power gain of 110 dB!

While Ferranti specifies the ZN414's frequency range as being 150 kHz to 3 MHz, the IC has been operated successfully at a frequency as high as 7 MHz. Quite possibly, the top frequency limit will go even higher than that.

The power considerations for the ZN414 are on a par with its technical specifications. The chip draws a mere 0.5 mA from power sources ranging between 1.2 and 1.6 volts. (Ferranti recommends that the IC be powered from a 1.3-volt source.) With this low-voltage source, the ZN414 can drive headphones with impedances ranging from 400 to 600 ohms without the need

for audio amplification. To drive a speaker, the IC's output can be easily capacitively coupled to the input of an amplifier to provide sufficient driving power.

While the agc action of the ZN414 is directly dependent upon the load impedance (hence the need for relatively high impedance phones), a capacitor can be used to isolate the two. With the capacitor between the IC and load, strong agc action will be observed.

If you would like to experiment with the IC, you can start with the projects described here. By special arrangement, the ZN414 IC's are available to POPULAR ELECTRONICS readers for \$5 each (plus 50c postage) from Ferranti Electric, Inc., East Bethpage Rd., Plainview, NY 11803.

# 2 AN FAA WEATHER RECEIVER

BY MICHAEL S. ROBBINS

**M**ORE than 50 Federal Aviation Administration stations throughout the United States transmit weather information valuable to travelers and others on the ground. Continuously repeated transcribed broadcasts on the FAA channels give wind speed and direction, ceiling, visibility, temperature, dew point, and barometric pressure for airports and air-travel routes, the latter often corresponding to highway routes.

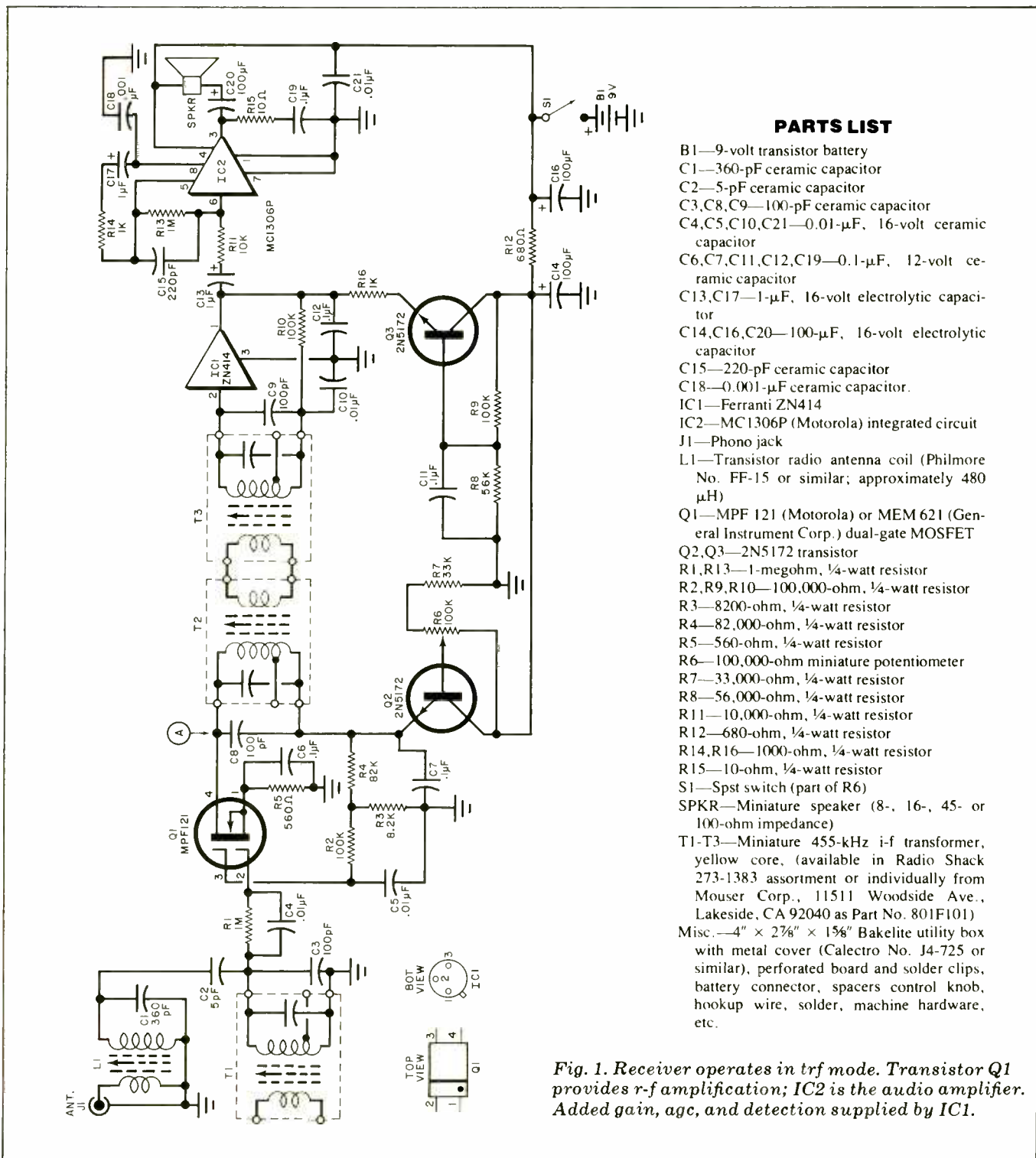

## PARTS LIST

- B1—9-volt transistor battery
- C1—360-pF ceramic capacitor
- C2—5-pF ceramic capacitor
- C3,C8,C9—100-pF ceramic capacitor
- C4,C5,C10,C21—0.01- $\mu$ F, 16-volt ceramic capacitor
- C6,C7,C11,C12,C19—0.1- $\mu$ F, 12-volt ceramic capacitor
- C13,C17—1- $\mu$ F, 16-volt electrolytic capacitor
- C14,C16,C20—100- $\mu$ F, 16-volt electrolytic capacitor
- C15—220-pF ceramic capacitor
- C18—0.001- $\mu$ F ceramic capacitor.
- IC1—Ferranti ZN414
- IC2—MC1306P (Motorola) integrated circuit
- J1—Phono jack
- L1—Transistor radio antenna coil (Philmore No. FF-15 or similar; approximately 480  $\mu$ H)
- Q1—MPF 121 (Motorola) or MEM 621 (General Instrument Corp.) dual-gate MOSFET
- Q2,Q3—2N5172 transistor
- R1,R13—1-megohm, 1/4-watt resistor
- R2,R9,R10—100,000-ohm, 1/4-watt resistor
- R3—8200-ohm, 1/4-watt resistor
- R4—82,000-ohm, 1/4-watt resistor
- R5—560-ohm, 1/4-watt resistor
- R6—100,000-ohm miniature potentiometer
- R7—33,000-ohm, 1/4-watt resistor
- R8—56,000-ohm, 1/4-watt resistor
- R11—10,000-ohm, 1/4-watt resistor
- R12—680-ohm, 1/4-watt resistor
- R14,R16—1000-ohm, 1/4-watt resistor
- R15—10-ohm, 1/4-watt resistor
- S1—Spst switch (part of R6)
- SPKR—Miniature speaker (8-, 16-, 45- or 100-ohm impedance)
- T1-T3—Miniature 455-kHz i-f transformer, yellow core, (available in Radio Shack 273-1383 assortment or individually from Mouser Corp., 11511 Woodside Ave., Lakeside, CA 92040 as Part No. 801F101)
- Misc.—4"  $\times$  2 7/8"  $\times$  1 5/8" Bakelite utility box with metal cover (Calectro No. J4-725 or similar), perforated board and solder clips, battery connector, spacers control knob, hookup wire, solder, machine hardware, etc.

Fig. 1. Receiver operates in trf mode. Transistor Q1 provides r-f amplification; IC2 is the audio amplifier. Added gain, agc, and detection supplied by IC1.

The station identifications given on the FAA channels consist of two or three letters in tone-modulated code. The rest of the broadcasts are spoken.

You can build a compact, portable FAA weather receiver with the aid of the Ferranti ZN414 linear integrated circuit. In tests, this receiver provided good re-

ception (with its built-in antenna) within a 125-mile radius of station IGD in Inglewood, Calif.

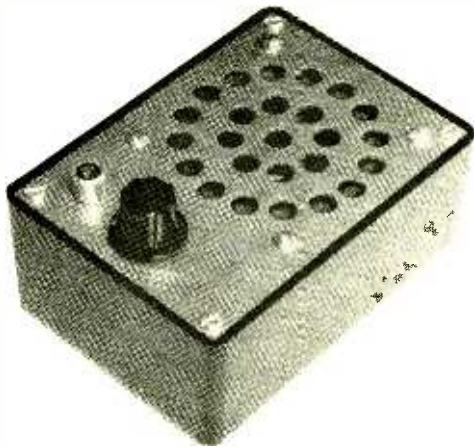

Front of receiver has holes drilled for antenna jack, speaker and sensitivity control.

**About the Circuit.** The receiver's circuit, shown schematically in Fig. 1, operates in a tuned-radio-frequency (trf) mode. MOSFET transistor *Q1* serves as the r-f amplifier stage, while the Ferranti one-chip radio IC (*IC1*) provides more gain, agc, and detection. The audio amplifier, *IC2*, delivers 0.25 watt of power to the speaker. Ferritecore broadcast-band antenna coil *L1* and three 455-kHz i-f transformers (*T1-T3*) with extra capacitors tune the receiver to the 300-400-kHz band. However, although the system covers the entire band, it is basically a single-frequency receiver.

**Construction.** The entire receiver can be assembled on a 3¾-in. by 2½-in. piece of perforated board with holes spaced on 0.1-in. centers. Parts placement is not critical, but the general layout shown in Fig. 2 should be followed to avoid oscillations.

All components are mounted on the metal plate of the utility box. Hence, you must drill a number of holes through the plate to allow the speaker's sound to escape. Also, four holes are needed for speaker and board assembly mounting, and mounting must be made for sensitivity control *R6* and antenna jack *J1*. Although a 2½-in. speaker is shown in Fig. 2, a smaller speaker would leave enough panel space for three access holes over the slugs of the i-f transformers to facilitate tuning. Use three spacers and appropriate hardware to mount the speaker and board assembly on the metal plate. The battery can be sandwiched between the spacer and the wall of the utility box to keep it firmly in place.

**Tune-Up.** Initial tune-up of the receiver is accomplished as follows: Clip a short antenna to point *A* in Fig. 1. Set sensitivity control *R6* to minimum, and adjust the slugs in *T3* and then *T2* for maximum sound output from the speaker on the desired FAA weather channel. You may hear some air navigation stations in addition to the weather broadcast.

Connect the antenna to *J1*. Then set *R6* to maximum sensitivity or as high as needed to hear the station. Adjust *L1* and *T1* for maximum signal while reducing the sensitivity. Remove the external antenna and readjust *L1* and *T1* through *T3* for best results with only the built-in ferrite antenna. The antenna coil is directional; so, rotate the receiver for best results. ◇

Fig. 2. Follow parts layout shown in photo to minimize the chance of oscillations occurring.

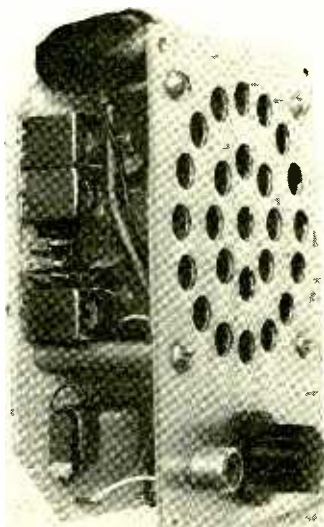
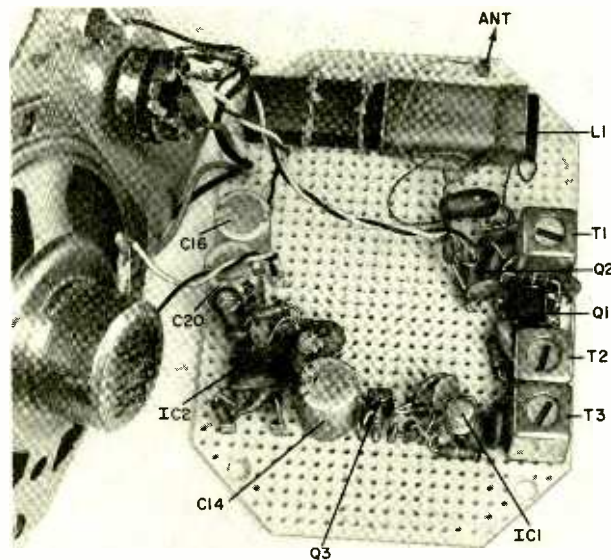

Photo shows how perforated board, with the components, is attached to the front panel.

# Low-Cost Remote Control of Appliances & Lights

BY GEORGE A. ELLSON

*Circuit is triggered on and off by a flashlight's beam*

**R**EMOTE control systems have always been popular as step, energy, and time savers. Invalids find them eminently practical for controlling electrical appliances, lights, and radio and TV receivers.

Depending on the specific application and the degree of control desired, a remote-control system can be expensively elaborate or very simple in design. Perhaps the most practical in economy and design is the simple light-activated system of the type described in this article. This system should cost roughly \$19 for all parts. It is virtually foolproof to operate, requir-

ing only an ordinary flashlight to trigger it on and off. The system will control virtually any load rated at up to 4 amperes or 450 watts.

**About the Circuit.** Transistors *Q1* and *Q2* in Fig. 1 form a regenerative bistable switch, using *Q3* as the collector load for *Q2*. The voltage across *R8* is high when *Q3* is cut off and low when *Q3* is saturated. The condition of *Q3* depends on the voltage at the base of *Q1*, which is in turn dependent on the resistance of the *LDR1/LDR2* voltage divider. Light-dependent resistors *LDR1* and *LDR2* are photosensitive

devices. When their active surfaces are dark, their resistance is at maximum. However, when the surfaces are illuminated, the resistance decreases, the amount of decrease governed by the intensity of the light.

If both *LDR*'s receive the same amount of light, the base bias of *Q1* remains the same. Now, if only *LDR1* is illuminated, its resistance drops and causes *Q1* to go into cutoff. But if only *LDR2* were to be illuminated, its change in resistance would cause *Q1* to go into saturation. The fast regenerative action of the circuit will then cause *Q3* to go into saturation or

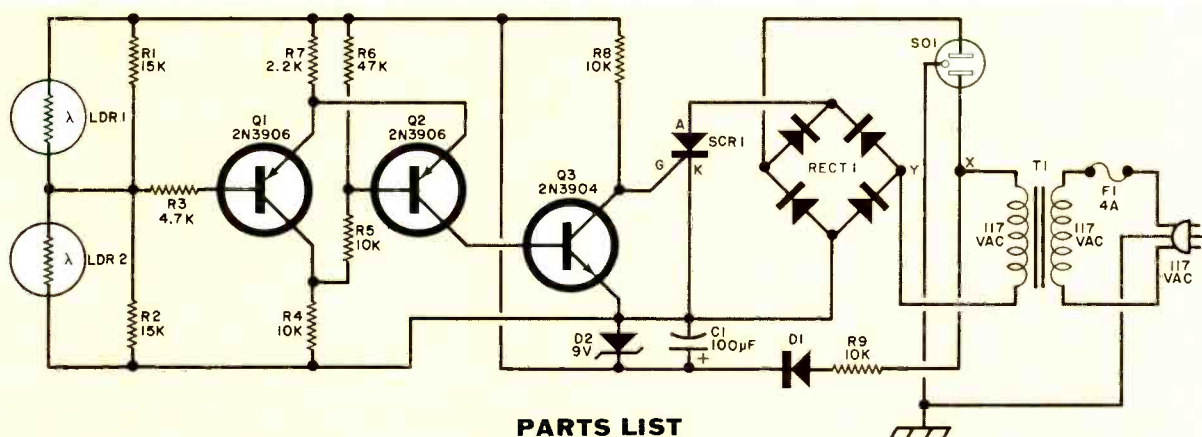

## PARTS LIST

C1—100- $\mu$ F, 15-volt electrolytic capacitor  
 D1—200-PIV, 500-mA silicon rectifier (1N647 or similar)  
 D2—9-volt,  $\frac{1}{2}$ -watt zener diode (1N960 or similar)  
 F1—4-ampere fuse  
 LDR1, LDR2—Cadmium-sulfide light-dependent resistor (Radio Shack No. 276-677 or similar)  
 Q1, Q2—2N3906 transistor

Q3—2N3904 transistor  
 R1, R2—15,000-ohm,  $\frac{1}{2}$ -watt resistor  
 R3—4700-ohm,  $\frac{1}{2}$ -watt resistor  
 R4, R5, R8—10,000-ohm,  $\frac{1}{2}$ -watt resistor  
 R6—47,000-ohm,  $\frac{1}{2}$ -watt resistor  
 R7—2200-ohm,  $\frac{1}{2}$ -watt resistor  
 R9—10,000-ohm, 1-watt resistor  
 RECT1—200-PIV, 4-ampere (minimum) rectifier bridge assembly  
 SCR1—200-PIV, 4-ampere silicon con-

trolled rectifier (General Electric No. 106B or similar)  
 SO1—Three-wire chassis-mounting ac receptacle  
 T1—117-volt isolation transformer  
 Misc.—Three-wire line cord with plug (16 or 14 gauge); aluminum utility box; printed circuit board or perforated board and solder clips; spacers; hookup wire; fuse socket; machine hardware; solder; etc.

Fig. 1. Relative resistances of *LDR1* and *LDR2* determine operation of bistable switch made up of *Q1* and *Q2*.

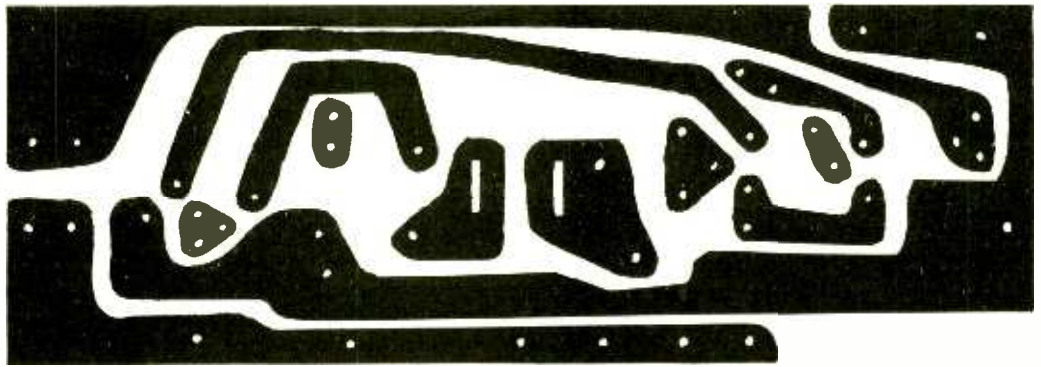
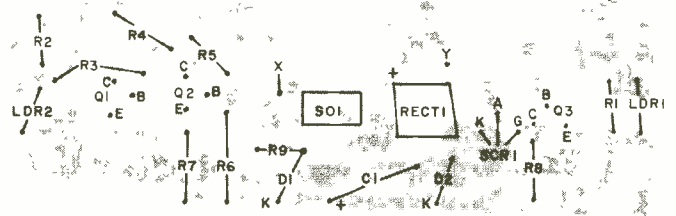

Fig. 2. Actual-size foil pattern for the printed circuit board is shown above. The component placement diagram is at right.



become cut off according to which of the LDR's receives the light.

Once the bistable switch goes into a given state, it will remain in that state (as long as power is applied to the circuit) until the opposite LDR is illuminated.

Resistor *R8* determines the level of the gate voltage applied to *SCR1*. When *Q3* is saturated, this gate voltage is minimum. Conversely, when *Q3* is cut off, the gate voltage is at maximum.

The SCR is connected in series with rectifier assembly *RECT1* and control socket *SO1* across the power line. With no filter capacitor in the circuit, the negative-going ac line alternations are "folded up" to produce 120 positive-going half cycles/second on the anode of *SCR1*. The SCR will not conduct until its gate is made positive with respect to the voltage on the cathode. When this occurs (*Q3* will be cut off), the SCR conducts and powers the electrical device plugged into *SO1*. The SCR will remain conducting for as long as the gate voltage is applied to it. When *Q3* is triggered into saturation, the SCR automatically turns off when the voltage applied to its anode reaches the zero point. Then the device plugged into *SO1* has its power cut off.

Resistor *R9*, diode *D1*, capacitor *C1*, and zener diode *D2* form the low-voltage supply for the transistor circuit.

**Construction.** Building the light-activated remote control system is best accomplished with the aid of a printed circuit board, the actual-size

etching and drilling guide and components placement diagram for which are shown in Fig. 2. Note that all components, with the exception of *LDR1* and *LDR2* and *SO1*, mount on the component side of the board. The isolation transformer, *T1*, and the fuse, *F1*, can be mounted at any convenient point within the enclosure.

Start construction by mounting the components on the top side of the board, putting in *SO1* last. Pay particular attention to the polarities of the diodes, rectifier assembly and electrolytic capacitor *C1* and the lead orientations of the transistors and SCR. Resistor *R9* and diode *D1* mount to the board by only one lead each. (The lead that goes to the board connection for *D1* is the cathode.) The anode of *D1* and the free lead from *R9* get soldered together to complete the circuit. Trim off excess lead lengths on the foil side of the board.

Trim the leads of the photocells to  $\frac{3}{8}$  in. (9.53 mm). Solder the leads of *LDR1* and *LDR2* to the board's conductors in the appropriate locations. Let the photocells extend as far from the surface of the board as their trimmed leads will allow.

Fashion a pair of flat black tubes, each about an inch long and just large enough in diameter to fit over the cases of the photocells. These tubes (they can be made from heavy construction paper but *not* metal) serve as light shields to prevent erratic operation of the system where ambient lighting is variable.

Select an enclosure that will comfortably accommodate the circuit board assembly. The pc board layout

shown in Fig. 2 is designed for a two-wire power system. Hence, the case should be all-plastic or all-Bakelite. If you elect to go to a safer three-wire system, you can use a metal case; but make absolutely certain that all three wires from the power cord, socket, and *T1* (the latter mounted on the case instead of the board assembly) are properly connected to avoid shock hazard.

Before mounting the circuit board assembly in place, drill holes through the case directly in line with the photocells. Slide the light shields over the photocells, and mount the board in place.

**Operation.** The only device needed to trigger the remote control system is an ordinary flashlight. Use a table lamp to check out the system. While it is still plugged into the wall outlet, turn on the lamp. Then, without switching it off, unplug the lamp's cord from the outlet and plug it into *SO1*. Plug the line cord from the remote control system into the wall outlet.

Shine the beam of the flashlight into first one, then the other photocell hole. The lamp should come on and extinguish in step with the movement of the beam from one hole to the other.

The range of the remote control system is directly related to the distance between the photocells. The flashlight beam must be able to illuminate only one photocell at a time. If you desire greater range than the pc assembly setup allows, you can separate the photocells even more. In this case, use shielded cable between them and the circuit board. ♦

# Build A SINE-WAVE INVERTER

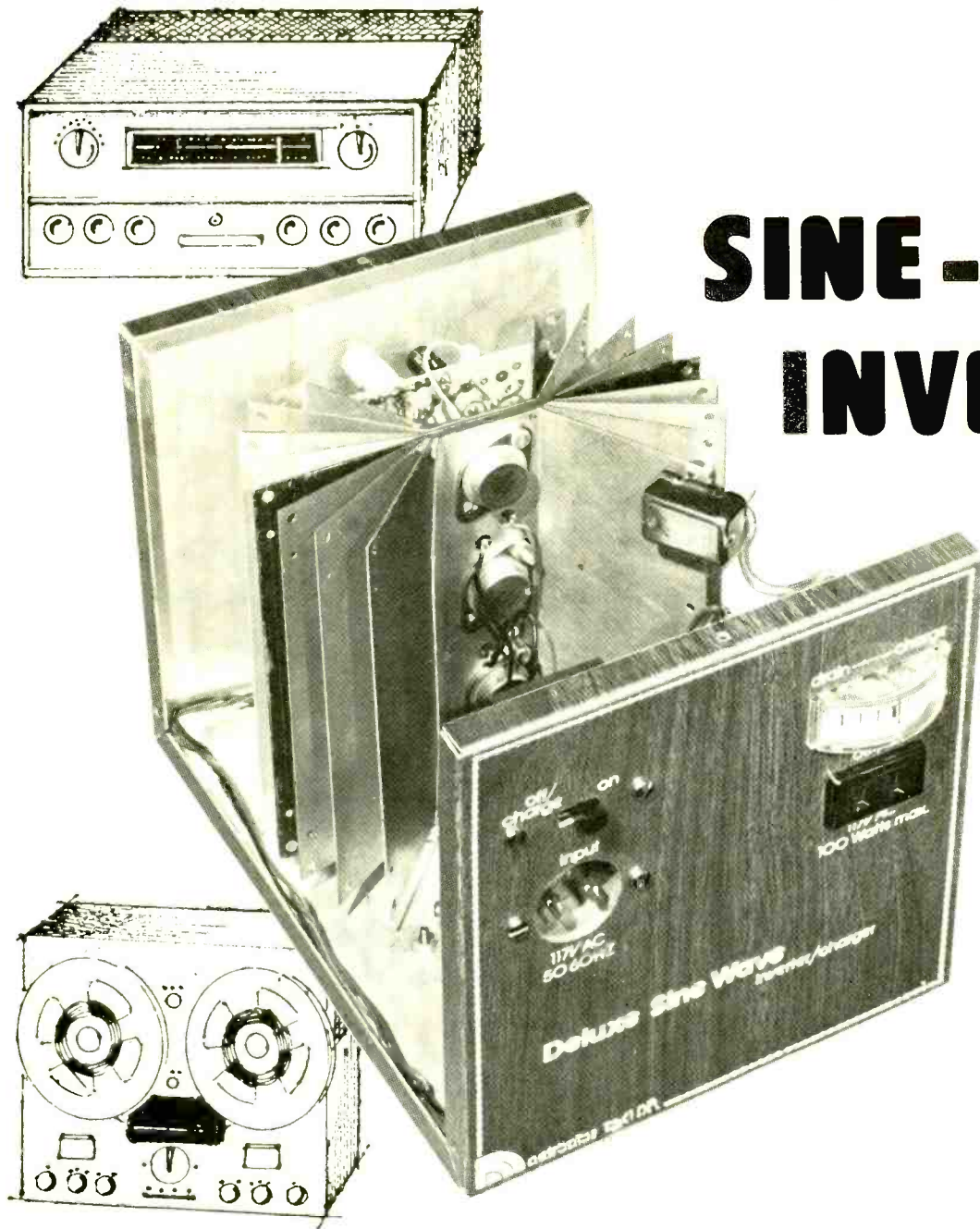

*Boosts 12 volts  
dc to 117 volts  
ac at 100 watts,  
and also  
recharges  
storage batteries.*

BY MARTIN MEYER

**C**AMPING OUT," whether it be in one of the new modern campers, a trailer, a tent, or even a boat, is one of today's most popular ways of "getting away from it all." There always comes a time, however, when we miss some of the creature comforts that we left at home—comforts that can only be provided by electrical appliances. Unfortunately, appliances that work on 12 volts dc are relatively expensive.

You can, however, use a dc-to-ac inverter, enabling you to utilize ac equipment you already own. As some readers might have already discovered, though, most of these devices deliver a form of square wave that prevents their use with equipment that is

sensitive to the interference caused by square waves. This includes TV receivers, audio equipment, CB gear and some test instruments. With the inverter described here, you can now get 117 volts of 60-Hz sine-wave power at 100 watts from a conventional 12-volt battery system. In addition, the in-

verter can be used to recharge vehicle batteries at 15 amperes from any 117-volt, 60-Hz power source.

The inverter can also be preset to deliver power at any frequency from 50 to 400 Hz, making it useful for operating some surplus electronic gear designed for 400 Hz. As an integrated standby power source it can even be used for power-failure emergencies in the home.

## SPECIFICATIONS

<b>Input:</b>	12 V dc at 14 A
<b>Output:</b>	117 V ac, 50-400 Hz, 100 W
<b>Distortion:</b>	Less than 10% at 100 W
<b>Charge Current:</b>	15 A max. (self- limiting)

**How It Works.** As shown in Fig. 1, the first stage in the inverter is a low-distortion sine-wave oscillator (*IC1A*) whose frequency can be adjusted by *R1*. The output of the oscillator is amplified and isolated from the load by a combination of an op amp and

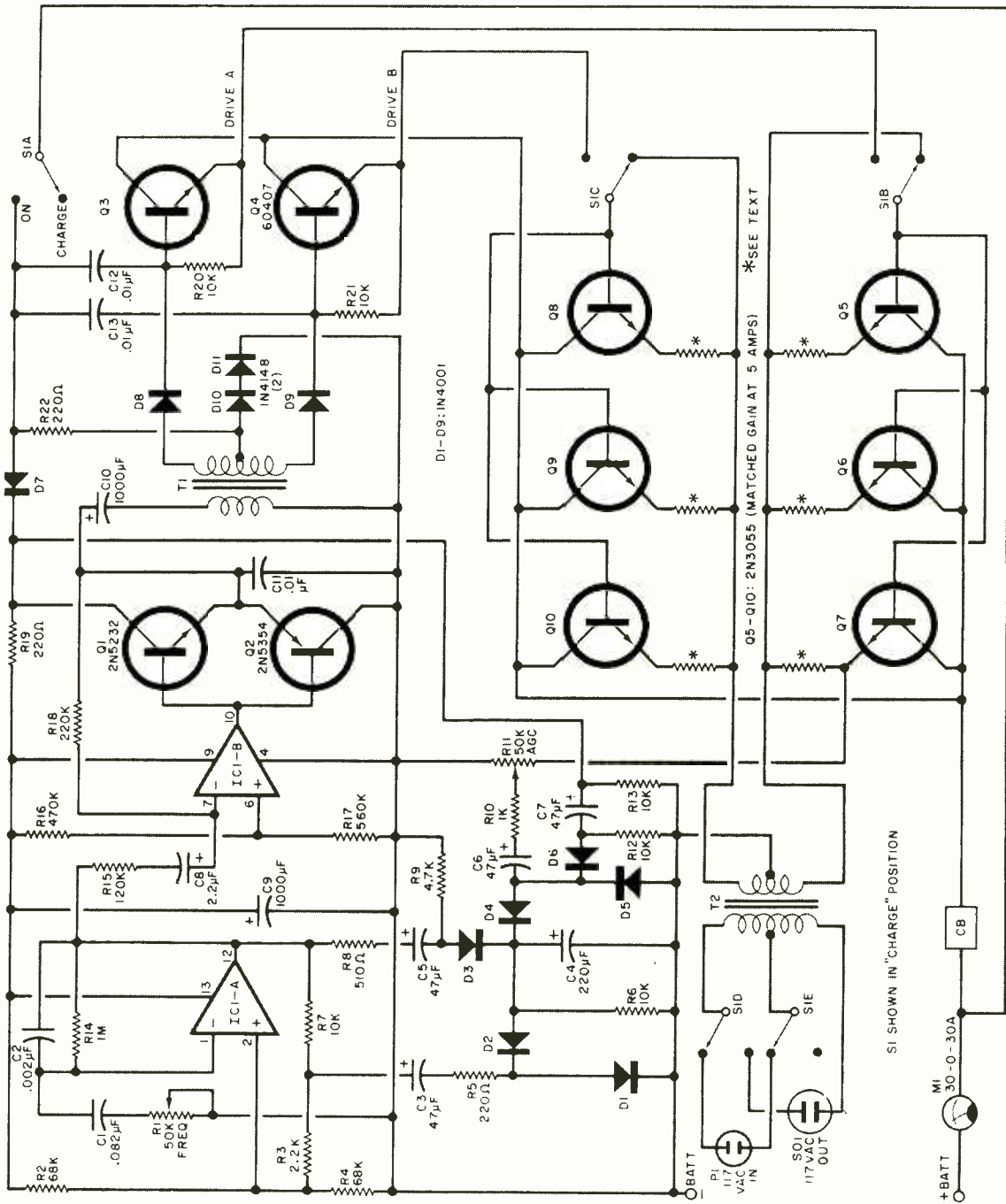

Fig. 1. A stable op amp audio oscillator is used to drive six high-power transistors, delivering 117 volts sine wave at any frequency between 50 and 400 Hz and with 100 watts of power.

## PARTS LIST

- C1—0.082- $\mu$ F Mylar capacitor  
 C2—0.002- $\mu$ F disc capacitor  
 C3, C5, C6, C7—47- $\mu$ F, 16-volt electrolytic capacitor  
 C4—220- $\mu$ F, 16-volt electrolytic capacitor  
 C8—2.2- $\mu$ F, 16-volt electrolytic capacitor  
 C9—1000- $\mu$ F, 16-volt axial-lead electrolytic capacitor  
 C10—1000- $\mu$ F, 16-volt, pc-type electrolytic capacitor  
 C11, C12, C13—0.01- $\mu$ F disc capacitor  
 CB—18-A circuit breaker (Littlefuse)  
 D1 to D9—1N4001 diode  
 D10, D11—1N4148 diode  
 IC1—747 dual op amp  
 M1—30-0-30-A meter  
 P1—117-volt male socket  
 Q1—2N5232 transistor  
 Q2—2N5354 transistor  
 Q3, Q4—2N5298 transistor (RCA)  
 Q5 to Q10—2N3055 (matched gain at 5A)  
 R1, R11—50,000-ohm potentiometer  
 Following resistors are 10%, 1/4-watt:  
 R2, R4—68,000 ohms  
 R3—2200 ohms  
 R5, R19, R22—220 ohms  
 R6, R7, R12, R13, R20, R21—10,000 ohms  
 R8—510 ohms  
 R9—4700 ohms  
 R10—1000 ohms  
 R14—1 megohm  
 R15—120,000 ohms  
 R16—470,000 ohms  
 R17—560,000 ohms  
 R18—220,000 ohms  
 S1—5-pole, double-throw switch  
 S01—117-volt chassis-mounting socket  
 T1—1:3 step-up driver transformer  
 T2—12-V/117-V, 18A primary output transformer (see below)  
 Misc.—Suitable chassis, rubber feet, grommet for battery lines, press-on type, silicone grease, aluminum for heat sink, 3/4" standoff insulators.

Note—The following are available from Ne-Tronics Research and Development Ltd., 333 Litchfield Rd., (Rt. 202), New Milford, CT 06776: complete kit including case and heat sink at \$69.95, plus \$3.00 postage and handling. Also available separately are: output transformer T2 at \$27.95; driver transformer T1 at \$4.00; S1 at \$2.70; meter M1 at \$4.50; circuit breaker at \$3.00; six matched 2N3055 transistors at \$12.00; pc board at \$4.00. Separate part orders add \$2.00 postage and handling. Connecticut residents add sales tax.



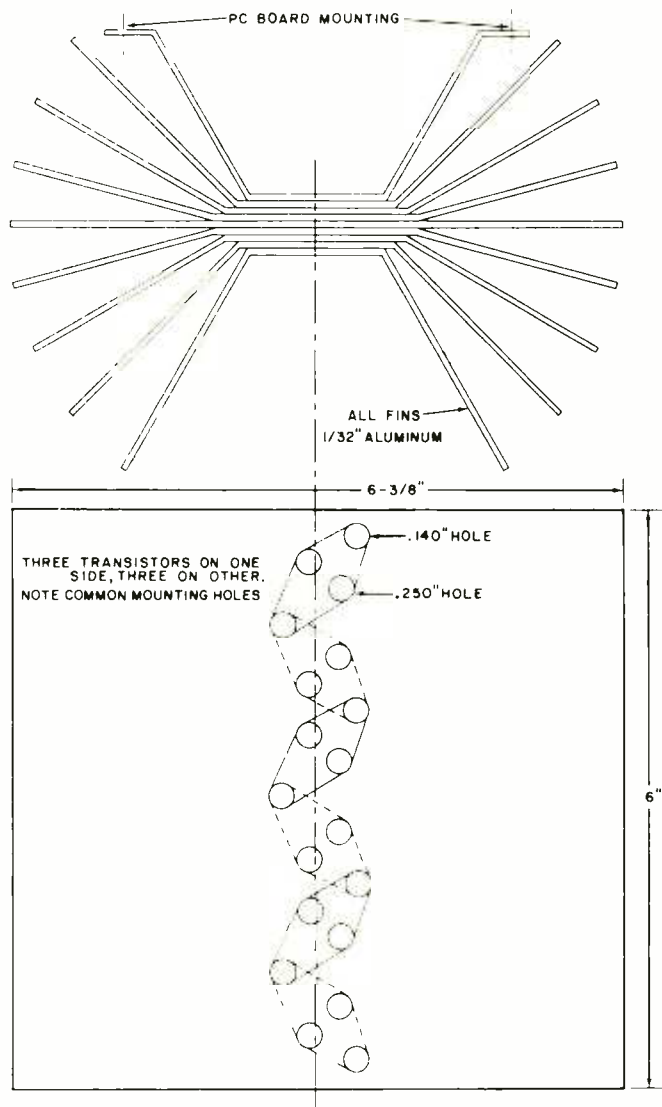

Fig. 2. Instructions and dimensions for making the heat sink. It must have at least 500 sq. in. of cooling surface.

discrete-transistor class-B pair (IC1B, Q1 and Q2) and T1.

Transistors Q3 and Q4 are medium-power amplifiers, each one Darlington-connected to three high-power transistors (Q8, Q9, Q10 and Q5, Q6, Q7). Transformer T2 is the load for the high-power transistors and provides the 117-volt output at the preset sine-wave frequency.

Load regulation is provided by feedback from the emitter of Q7 to potentiometer R11 and then to the oscillator. Regulation from no load to full load is better than 6%.

When switch S1 is set to CHARGE, the circuit (except for Q5 through Q10) is disconnected from the battery, and the six high-power transistors act as rectifiers. The secondary of T2 is connected so that the proper charging current is obtained.

An 18-ampere circuit breaker is mounted on the output stage heat sink

to monitor the temperature and current drain. If the heat sink gets too hot due to improper ventilation, the current rating of the circuit breaker reduces proportionately. Thus, the inverter is protected from improper mounting or application.

The zero-center ammeter (M1) indicates the current drain when the circuit is inverting and the charging current when it is recharging a battery.

**Construction.** The crucial element in the assembly is the construction of the heat sink. To keep the operating temperature below 100°C, the heat sink must have more than 500 square inches of area. Details of the construction are shown in Fig. 2. Note that there are nine sections of 1/32"-thick aluminum in the heat sink, with holes drilled to mount the six power transistors.

After drilling the holes for the trans-

istors, remove the burrs. The transistors share common mounting holes with three transistors on one side of the sink and three on the other. Use silicone grease under the transistors to insure intimate thermal contact with the heat sink. The transistor cases are not insulated from the sink as all collectors are connected in parallel. The heat sink is insulated from the metal case by four insulated stand-offs. Do not try to use a smaller heat sink or you will run the risk of damaging the transistors.

The remainder of the circuit is mounted on a pc board (Fig. 3). Note that the cases of diodes D10 and D11 are actually thermally bonded to the heat sink. The cutout in the board allows the diodes to contact the heat sink (with silicone grease to insure the contact). Transistors Q3 and Q4 are also mounted so they touch the heat sink. Their collectors are at the same potential as those of the power transistors. Drill suitable holes to attach the pc board to the lips on one end of the heat sink.

After selecting a chassis, mount the heat sink on four insulated stand-offs. The metal chassis must be floating, not connected to input or output.

The emitter resistors for transistors Q5 through Q10 are made of 14-inch lengths of #22 wire. It is important that the lengths of the resistors be as nearly the same as possible so that the transistors share equal amounts of the current. The secondary of T2 is at 117 volts ac so use care in routing the leads. Dress leads away from the heat sink and use wire rated at 105°C.

The leads from the inverter to the battery (through the rear of the case) may carry as much as 18 amperes, so use heavy gauge wire or lengths of line cord with both leads in parallel for each side. If the connection is very long, use four parallel wires for each side to keep the voltage drop in the leads to less than 0.5 volt.

When assembly is complete, check again to make sure there is no connection between the case and the input or output.

**Testing.** With the cover off, set R1 and R11 to their mid-positions. Connect the battery leads to a high-current 12-volt source (vehicle battery). Turn the inverter on and note that the meter indicates less than 2 A drain. If this is not the case, immediately turn off the unit and determine the reason.

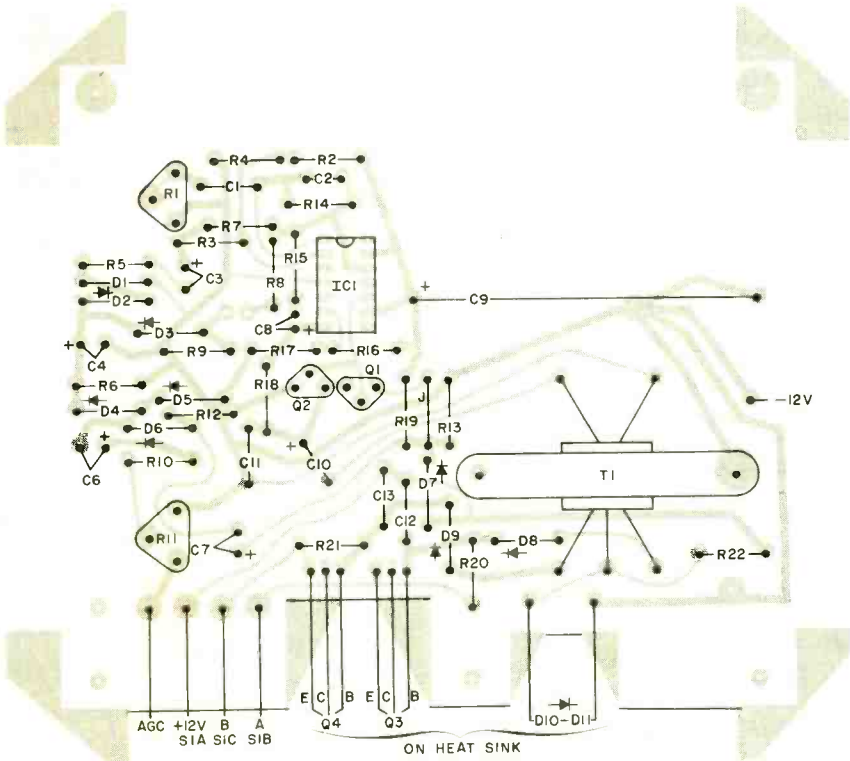
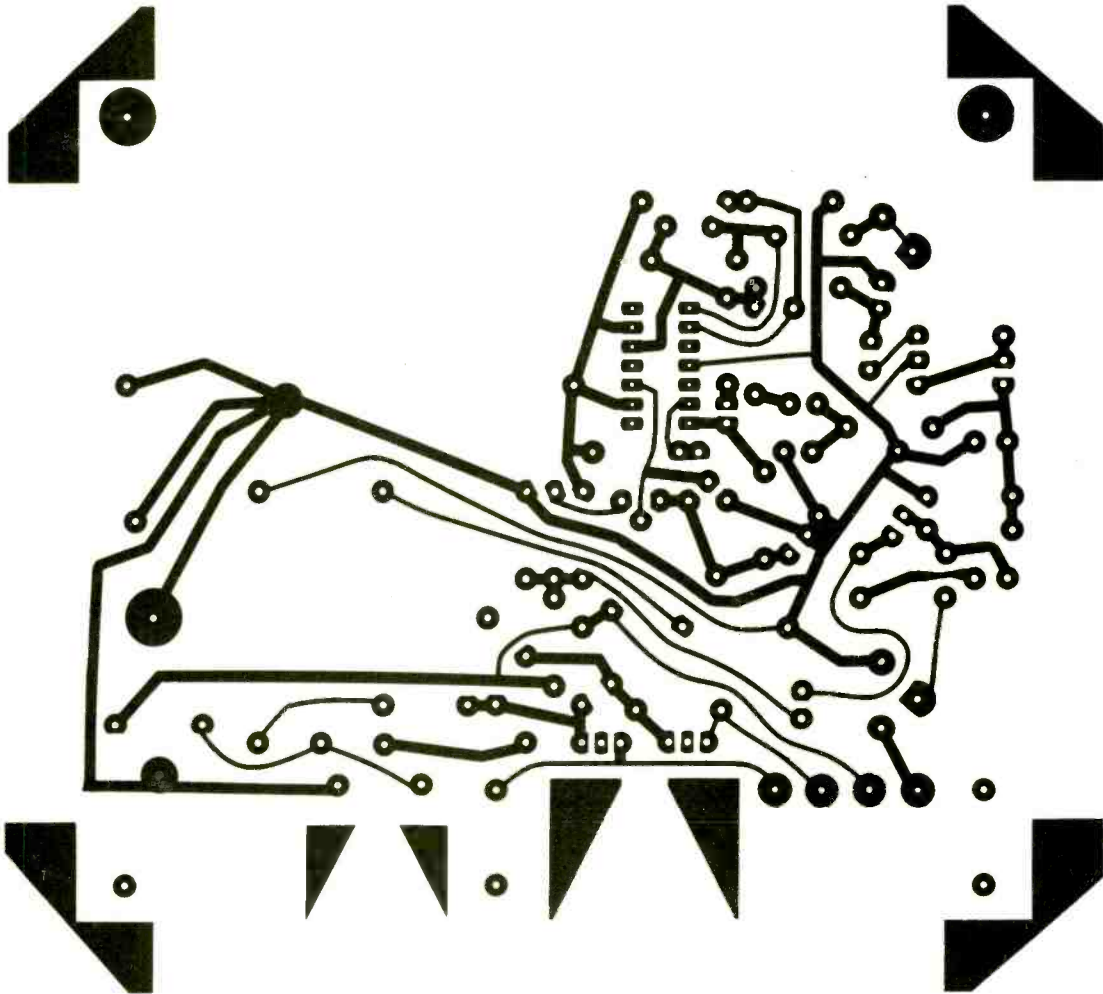

Fig. 3. Etching and drilling guide and component layout for pc board. D10, D11, Q3, and Q4 touch heat sink.

If the meter indication is correct, turn off the inverter and connect a 117-volt ac meter and a 100-watt lamp to SO1. Keep in mind that this is a hazardous voltage. Turn the inverter on and adjust R11 to obtain 117 volts at SO1.

Use a frequency counter or the circuit shown in Fig. 4 to adjust R1 for 60 Hz. In using the circuit in Fig. 4, adjust R1 until the neon lamp does not flash (zero beat).



Fig. 4. Use this circuit to tune the inverter to 60 Hz.

**Operation.** This equipment, like any ac line-powered gear, must be treated with great care. The cabinet should be adequately ventilated at all times. The design is safe up to an ambient of 120°F. If the circuit breaker trips, check the ventilation and possibly reduce the output voltage slightly. It is good practice not to operate any electronic gear in an ambient in which a human is not comfortable. ♦

---

# SIMPLE TESTERS FROM "JUNKBOX" PARTS

BY JOSEPH E. TAYLOR

---

*Old Transistor  
radio parts  
can make:  
Audio Oscillator  
Crystal Oscillator  
A-F/R-F Amplifier*

**G**OOD test equipment can cost quite a bit of money; but if you are just interested in having some relatively simple items and have a well-stuffed "junk-box," you can put together a few really useful circuits.

The basic systems described here include an audio generator, which can also be keyed to make a code-practice oscillator; a simple transistor quality checker for either audio or r-f; an r-f oscillator that can be used to align either BCB radios or their i-f's; and an audio amplifier that can serve as a useful audio section for almost any experiment requiring a loudspeaker. Assembled from discarded semiconductor radio parts, these circuits can be put to many uses.

**Audio Oscillator.** Shown in Fig. 1, this circuit consists of an npn and a pnp transistor. With the values shown, it will produce a mid-range audio tone. If sock-

ets are used for the transistors, plugging a suspect transistor in the appropriate socket will produce an audio tone if the transistor is good.

A conventional Morse code key can be connected in series with the positive supply (at *J1*) and, with *S1* turned on and a speaker connected to the output, you have a code-practice oscillator. You can use this oscillator to check any type of audio amplifier by starting at the speaker and working back.

**Crystal Oscillator.** A simple crystal oscillator is shown in Fig. 2. The crystal (obtainable from any crystal supplier) should operate at about 228 kHz. The harmonics of this oscillator can be used in receiver alignment. For example, the second harmonic, which falls at 456 kHz, can be used for i-f alignment. A short wire antenna will serve to inject this signal into the radio being checked. For dial calibration, the upper harmonics

Fig. 1. Simple audio generator can also be used as a code-practice oscillator or audio transistor tester by substitution.

### PARTS LIST

- B1—1.5-volt C or D cell
- C1—0.47- $\mu$ F capacitor
- J1—Phono connector (optional)
- Q1—2N170 transistor
- Q2—2N107 transistor
- R1—1500-ohm,  $\frac{1}{4}$ -watt resistor
- R2—100-ohm,  $\frac{1}{4}$ -watt resistor
- S1—Spst switch
- T1—Miniature audio output transformer
- Misc.—Battery holder, transistor socket (2), perf board and clips, mounting hardware.

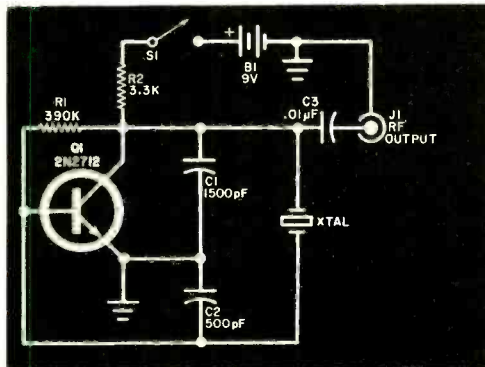
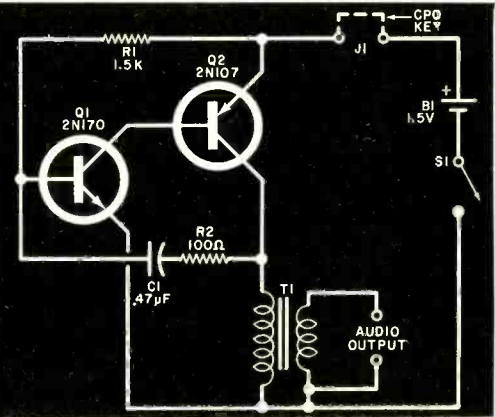

### PARTS LIST

- B1—9-volt battery
- C1—1500-pF mica capacitor
- C2—500-pF mica capacitor
- J1—Binding post
- Q1—2N2712 transistor
- R1—390,000-ohm resistor
- R2—3300-ohm resistor
- S1—Spst switch
- XTAL—228-kHz crystal
- Misc.—Battery holder and connector, transistor socket, crystal socket, PC or perf board, mounting hardware.

Fig. 2. This crystal oscillator can be used as a BCB i-f aligner with harmonics usable across the whole broadcast band.

Fig. 3. Three-transistor audio amplifier can have either audio (J2) or r-f (J1) inputs.

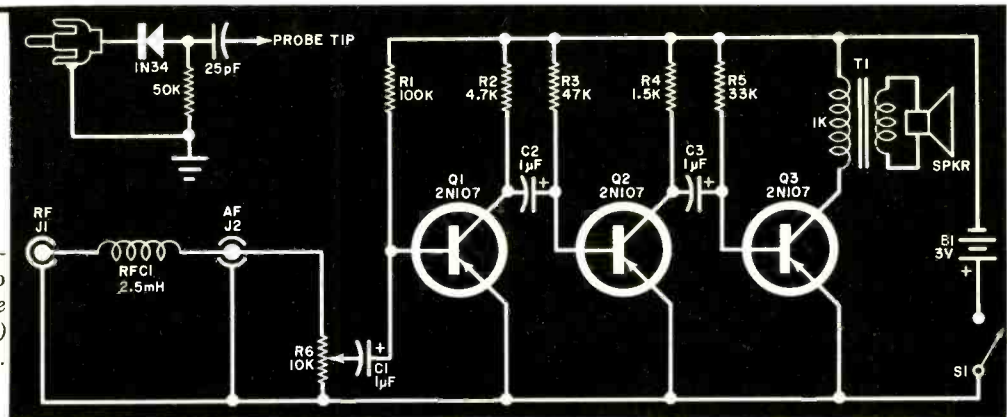

### PARTS LIST

- B1—3-volt battery (2 AA, C, or D cells)
- C1—C3—1- $\mu$ F, 10-volt electrolytic capacitor
- J1, J2—Phono connector
- Q1—Q3—2N107 transistor
- R1—100,000-ohm,  $\frac{1}{2}$ -watt resistor
- R2—4700-ohm,  $\frac{1}{2}$ -watt resistor
- R3—47,000-ohm,  $\frac{1}{2}$ -watt resistor
- R4—1500-ohm,  $\frac{1}{2}$ -watt resistor
- R5—33,000-ohm,  $\frac{1}{2}$ -watt resistor

- R6—10,000-ohm miniature potentiometer
- RFC1—2.5-mH r-f choke
- S1—Spst switch
- T1—1000-ohm primary miniature output transformer
- Misc.—Battery holder, PC or perf board, mounting hardware.
- For probe: 50,000-ohm,  $\frac{1}{4}$ -watt resistor; 25-pF capacitor; 1N34 diode; shielded cable; phono connector.

come in handy. For example, there are harmonics at 1368 and 1596 kHz for aligning the high end of the dial, while the harmonic at 684 kHz is useful for the low end.

**Audio Amplifier.** The circuit shown in Fig. 3 is a conventional high-gain audio

amplifier having a selection of one or two inputs. The input at jack J2 is for conventional audio, while the input at J1 is for an r-f demodulator probe. (This is also shown in Figure 3.) This composite circuit can be used to check a radio from the antenna input through the final audio section.

**Construction.** The circuits can be assembled either individually or combined on either perf board or printed circuit board. They can all be mounted in a common chassis with pertinent switches and connectors on the top. As each element is constructed, it should be tested before final installation in the chassis.

Author's practical embodiment of electromechanical light chopper shown in Fig. 3. Calibration lamp is at left. An r-f transmitter triggers lamp.

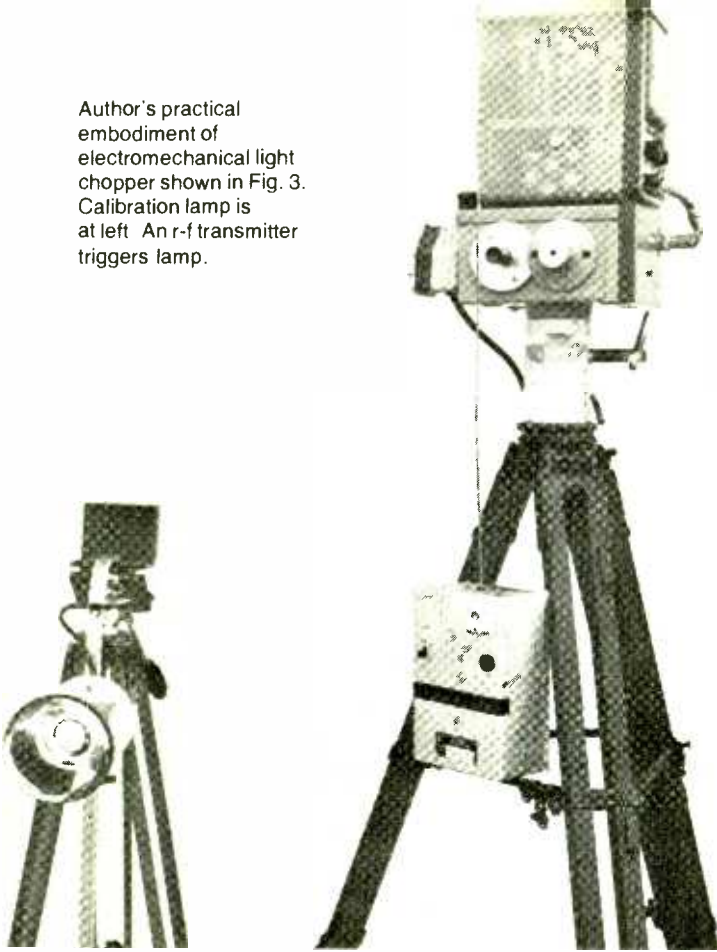

# Solid-State PHOTOCELLS FOR HOBBYISTS

*How light-sensitive semiconductors are used in practical circuits*

BY L. GEORGE LAWRENCE

**T**HIS article will illustrate how photo-cells are used in practical applications. In some of the circuits described here, we use an NSL-446 (National Semiconductors Ltd., 331 Cornelia St., Plattsburgh, NY 12901). It has a light-to-dark resistance ratio of about 1:1000 (11,400 ohms in light to 12,000,000 ohms in darkness). Maximum peak voltage is 420 V at peak power of 1 watt. These specifications make it suitable for a wide range of sensing and control functions and are typical of many high-power photoconductive cells.

A good way to experiment with photo-cells without damaging them is to use alligator clips for temporary connections. Many cells with pin-type leads are heat sensitive. Thus, both substrates and light-sensitive materials can be dam-

aged by frequent soldering. To be on the safe side, use a simple heat-sink tool (Miller No. 80, for example) or long-nose pliers when soldering.

**Daylight-Operated Controller.** A basic application for the NSL-446 is the "house sitter" shown in Fig. 1. The photocell is exposed to outdoor light and it automatically turns on a lamp circuit when the sun goes down. Potentiometer *R2* and relay *K1* provide current limiting for the photocell. Half-wave rectification is provided by *D1*, and *C1* prevents relay chatter. During daylight hours, the photocell's resistance is low, and the relay is kept energized. The lamp circuit is thus turned off. When the resistance of the photocell rises with waning light towards the end of the day, the relay

drops out and the lamp circuit is energized. The neon pilot light indicates that the unit is on and ready to operate.

**Choppers.** When the circuit shown in Fig. 2 (called a photoelectric chopper) is used with a conventional ac-type oscilloscope, the latter can be used to display dc signals. The photocell, *PC1*, is optically coupled to a 1/4-watt neon lamp, *I1*. Since the cell is gated on and off by the neon lamp's flicker frequency of 60 Hz, a dc signal applied to the input of the circuit is chopped and appears as ac across *R2*. High dc input provides an analog increase in the amplitude of the ac output. This arrangement works well in many non-critical applications. The excitation current can be derived from the scope's power supply.

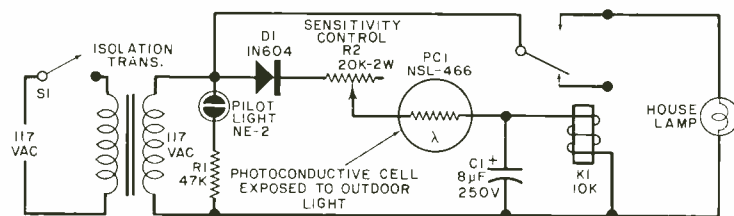

Fig. 1. Simplicity of application of photoconductive cells is demonstrated in this construction project. House Sitter stops conducting at night, making relay drop out and turn on lamp.

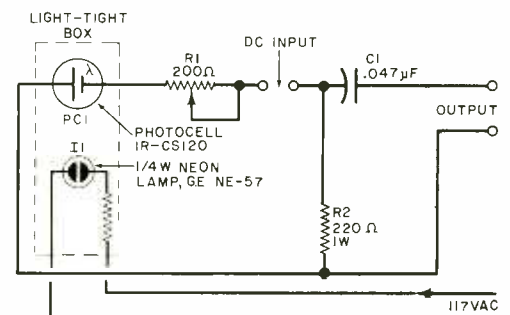

Fig. 2. Photoelectric chopper for converting dc to amplitude-variable ac for oscilloscope.

The ac processing of a photocell's dc signal is desirable in many applications where the inherent drift of "straight" dc amplifiers (including low-cost IC's) cannot be condoned. In the setup shown in Fig. 3, for instance, a motor-driven wheel "chops" the light to the photocell. The frequency of the electromechanical chopper is determined by the number of apertures in the wheel and the speed of rotation. If, for example, the wheel is driven by a synchronous motor at 1800

rpm and has 4 holes, the effective chopping frequency is  $(1800/60) \times 4 = 120$  Hz. The chopped dc (actually a square-wave signal) across  $R1$  is amplified and applied to a meter readout through a full-wave rectifier.

**Audio Use.** Photoconductive cells can be used in many fascinating experiments and money-saving conveniences in audio work.

The circuit shown in Fig. 4, for exam-

ple, provides light-controlled feedback of an audio amplifier. If the intensity of the lamp (controlled by  $S1$ ) is sufficient to lower the resistance of the photocell, part of the amplifier's output signal is fed back to the input. Depending on the lamp's brightness, which is set by potentiometer  $R1$ , powerful feedback oscillations of variable intensity can be obtained. Thus, the amplifier can be converted into a single-frequency "cue" generator, an aid when cutting master tapes.

If desired, the amplifier can trigger a special-effects instrument. The photocell can be activated by the dominant light of a color organ during original deep bass sequences, with the photocell's output triggering a solenoid-operated drum.

In the circuit shown in Fig. 4,  $R2$  provides a "keep-alive" current path for the cell. Since its own resistance is high, no feedback will ensue unless resistive circuit values are lowered by the activated photocell. Best results can be obtained by actual experimentation.

**Power Generators.** Photovoltaic cells are used primarily as sources of dc power. An excellent application is in the generation of power for emergencies. As shown in Fig. 5, silicon or selenium cells in series can furnish charging currents to a secondary battery, with current-blocking diodes to protect the cells from reverse current. The ammeter (optional) indicates the total amount of charge.

Since the output of the cells is governed by the amount of ambient sunlight, special allowances must be made in computing charging rates and effective load resistances.

In typical applications, solar batteries act as trickle chargers for conventional batteries that furnish high dc power (100 A or more) for a few minutes at a time. This concept is used in satellite applications, with silicon photocells assembled in arrays on the satellite.

An excellent hobby project is the sun-powered emergency radio receiver shown in Fig. 6. It is simple and reliable, with a 1.5-volt standby battery (C or D cell) for sunless days. For use on land or at sea, the receiver works best with a true earth ground and a long antenna. The ground can be a metal frame or a submerged metal plate in the case of a boat. A small transistor amplifier can be added to improve the power output. Wiring and layout are not critical, but the electronic components should be housed in a sturdy metal container.  $\diamond$

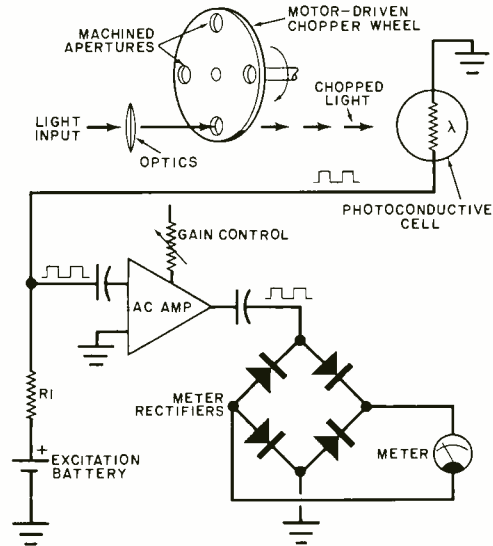

Fig. 3. Electromechanical light chopper has rotating aperture wheel, amplifier, meter.

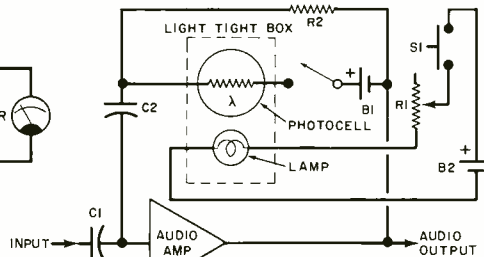

Fig. 4. Photocell feedback for audio effects.

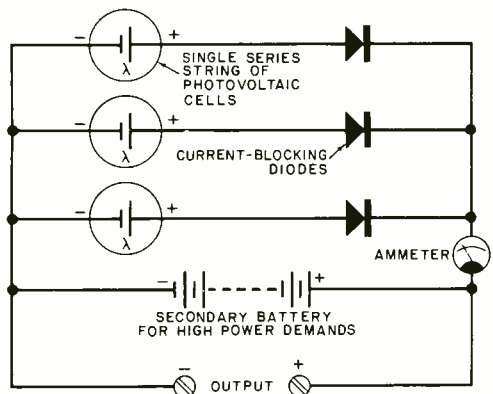

Fig. 5. Solar cells in series-parallel array.

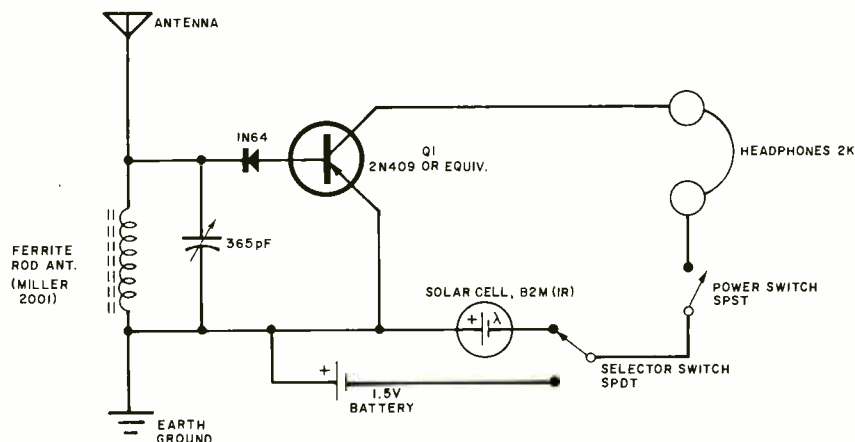
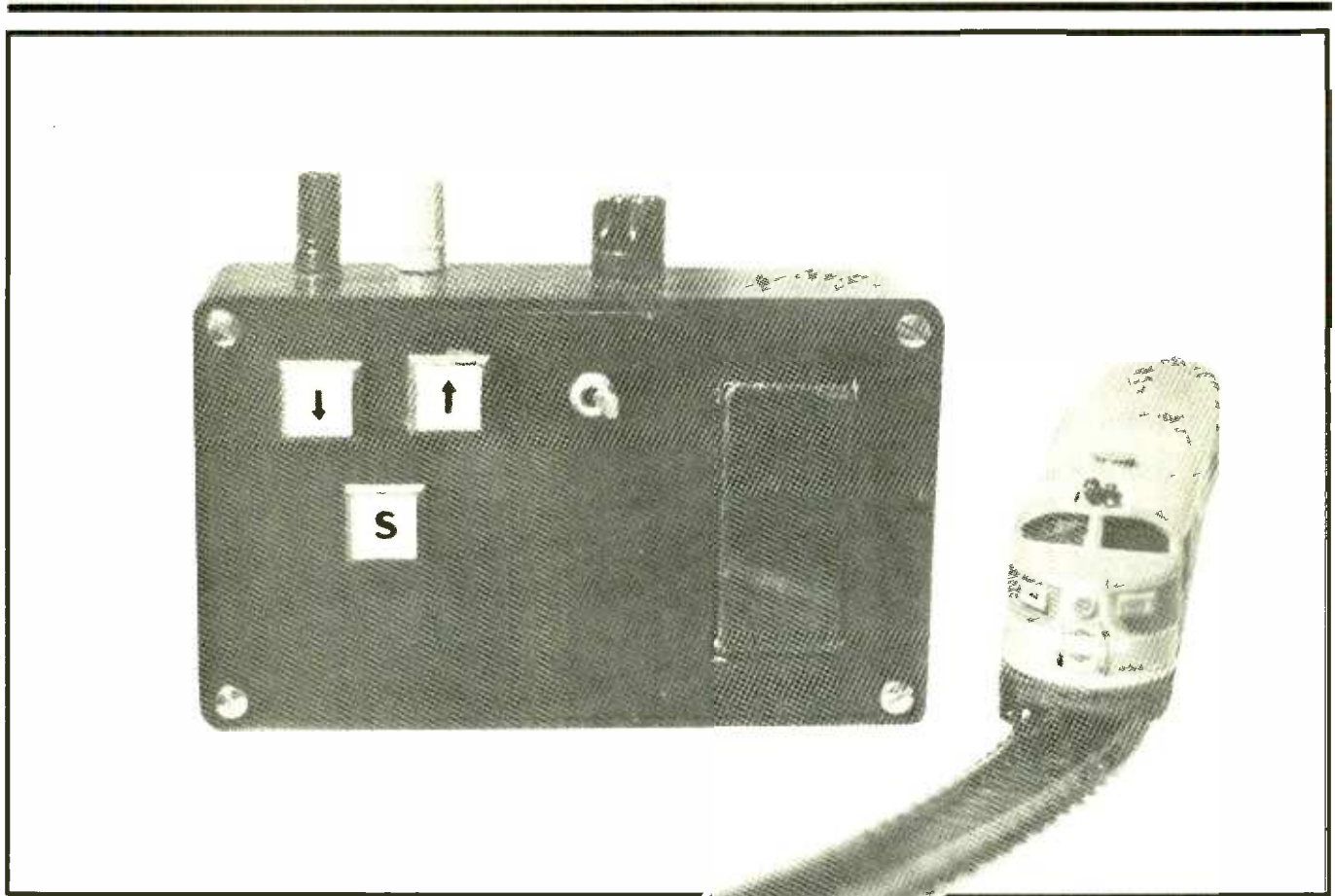

Fig. 6. Sun-powered emergency radio receiver.



# IC Speed Controller for HO Model Railroads

*Precision low-cost device provides  
full control flexibility and simple  
speed indication option*

BY ROBERT D. PASCOE

**W**ITH A PAIR of integrated-circuit operational amplifiers and a handful of parts, you can build a precision speed controller for HO-gauge model railroads at minimal cost. The solid-state controller features forward/reverse, stop, increase-speed, and decrease-speed switches for full control flexibility. In addition, optional lighted pushbutton switches can be used to provide a vis-

ual indication of how fast the train is moving on its tracks. The faster the train moves, the brighter the light from the lamps.

**About the Circuit.** Operational amplifier *IC1*, in conjunction with transistors *Q1* and *Q2* (see schematic diagram), forms a voltage regulator circuit. The output voltage from this circuit is determined by the voltage at the

wiper at potentiometer *R2* and the dc voltage across capacitor *C3*. Op amp *IC2* is connected in a voltage-follower configuration. The dc voltage across *C3*, the reference for the regulator, is a product of the time a constant current is "pumped" into the capacitor. The two current "pumps" in this system are made up of the *Q3* and *Q4* circuits, with *Q3* the negative and *Q4* the positive pump.

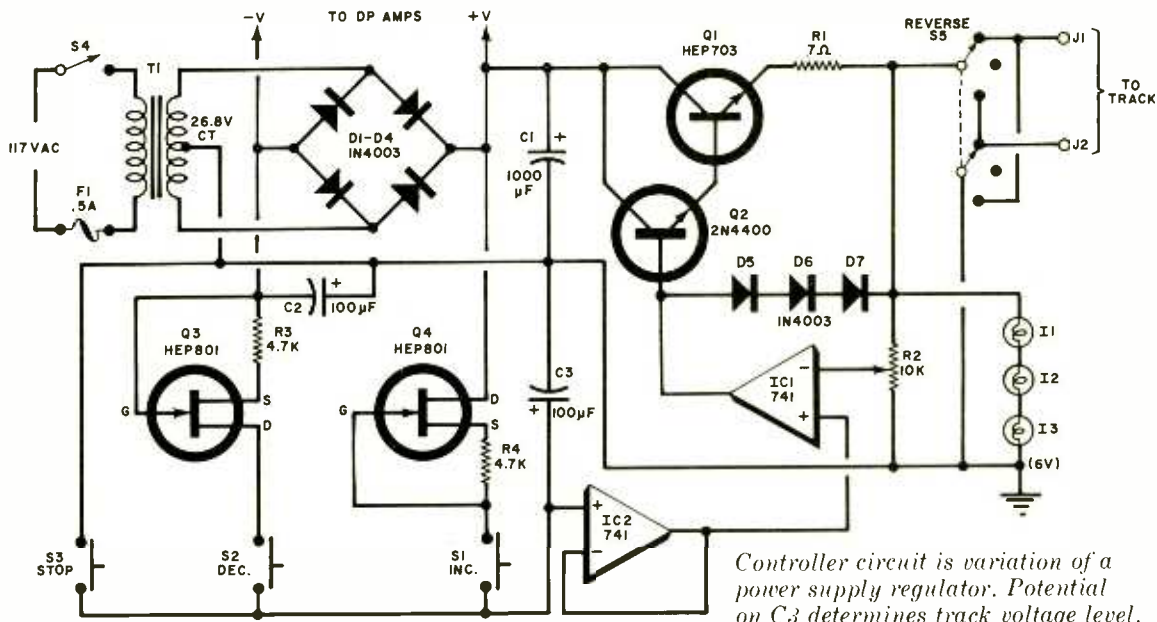

Controller circuit is variation of a power supply regulator. Potential on C3 determines track voltage level.

### PARTS LIST

C1—1000- $\mu$ F, 50-volt electrolytic capacitor  
 C2, C3—100- $\mu$ F, 50-volt electrolytic capacitor  
 D1-D8—1N4003 (or similar) silicon diode  
 F1—0.5-ampere fuse  
 I1-I3—6-volt pilot lamp (optionally in S1-S3)  
 IC1, IC2—741 operational-amplifier integrated circuit (or use dual version)  
 J1, J2—Banana jack (one black, one red)  
 Q1—HEP-703 power transistor (Motorola)

Q2—2N4400 transistor (or use Motorola HEP-736)  
 Q3, Q4—HEP-801 FET (Motorola)  
 R1—0.7-ohm resistor (four 3.3-ohm,  $\frac{1}{2}$ -watt resistors in parallel)  
 R2—10,000-ohm potentiometer  
 R3, R4—4700-ohm,  $\frac{1}{2}$ -watt resistor  
 S1-S3—Normally-open pushbutton switch (Use Switchcraft No. LUS-05-01 if built-in 6-volt lamp is desired)

S4—Spst slide or toggle switch  
 S5—Dpdt, center-off switch  
 T1—26.8-volt, 1-ampere transformer  
 Misc.—Heat sink for Q1; suitable enclosure; fuse holder; socket(s) for IC1 and IC2; perforated board and solder clips; line cord; strain relief or rubber grommet (for line cord exit hole); dry-transfer lettering kit; machine hardware; hookup wire; solder; etc.

Depressing increase speed switch S1 causes the output voltage at the tracks to increase. Conversely, depressing S2 causes the output voltage to decrease. And pressing stop switch S3 causes the output voltage to immediately drop to zero.

A visual indication of the speed at which the train is moving is obtained by observing how bright the light is from lamps I1-I3. One of these lamps is (optionally) inside each pushbutton switch. The greater the track voltage, the faster the train is moving on the tracks, and the brighter the lamps.

The three-diode current limiter composed of D5-D7 holds the current being fed to the tracks to approximately 1 ampere. Hence, the circuit is protected in the event the train tracks should accidentally be shorted to each other.

**Construction.** Owing to the simplicity of the circuit, the entire controller, except for T1 and the switches, can be mounted on a piece of perforated board with the aid of push-in solder

terminals and sockets for IC1 and IC2. Series-pass transistor Q1 must be mounted in an aluminum heat sink with about 9 sq in. (58 sq cm) of radiating area.

You can mount the circuit board assembly and transformer in any suitable enclosure. The control switches and potentiometer are best mounted on the top of the enclosure, while output jacks J1 and J2 are more conveniently located on the rear of the enclosure, as is the exit hole (strain relieved or rubber-grommet-lined) for the line cord.

**In Use.** The upper voltage limit to the tracks is determined by the setting of potentiometer R2. To adjust R2, depress increase-speed switch S1 for 10 seconds. The glow of the three lamps will increase in brilliance during this interval. Set R2 for the desired upper-limit track voltage.

The speed at which the track voltage increases and decreases is determined by the two current pumps (Q3 and Q4). With the components

specified in the Parts List, the voltage change rate is about 2 volts/second. Increasing the values of R3 and R4 decreases the rate of change, and vice-versa. ♦

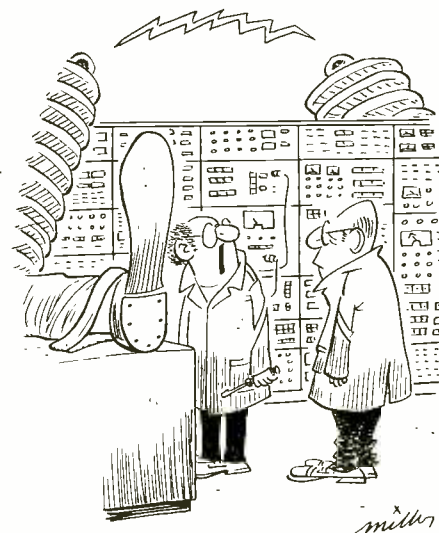

So why should the experimenter have to start from scratch when we can give it to them in kit form!



*Identifies leads on unknown transistors, indicates PNP or NPN polarity, and shows up bad devices*

# BUILD THE TRANSISTOR IDENTOMETER

BY JOHN T. BAILEY

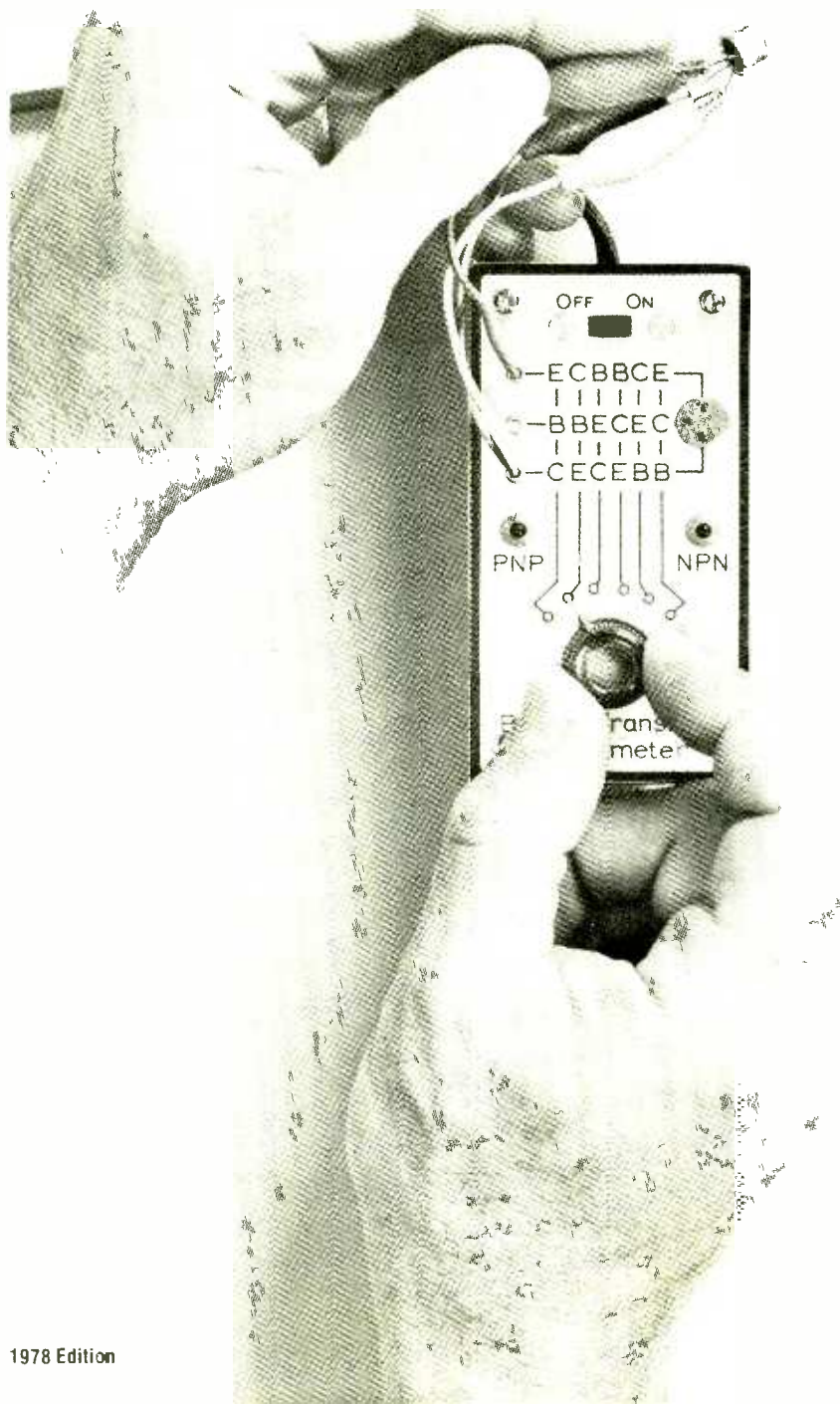

**M**OST experimenters have a drawer full of unidentified transistors which are of little use unless the leads and type (pnp or npn) can be determined. Actually, that's the only really important information needed to apply a transistor in a circuit—assuming it is "good" to begin with. Of course, it's nice to

know what the transistor's beta is, but this is not essential in many applications.

The Identometer was designed to provide a quick check of a transistor's leads and type. It operates on the basis that bipolar transistors will operate, but poorly, if the emitter and collector leads are interchanged without also reversing the power supply. Since a transistor has three leads, it is possible to connect them in six different ways. With a transistor plugged into the test circuit, the Identometer has a switch to make the six different connections. When the right one is selected, an indicator light comes on. The light also tells whether the unit is npn or pnp.

**Circuit Operation.** A schematic of the circuit is shown in Fig. 1. Note that  $T1$  has two secondaries, one serving as the power supply for the  $Q1$ -LED1 and  $Q2$ -LED2 circuits and the other for the unknown transistor. Transistor  $Q1$  saturates when the upper secondary voltage is in the positive half cycle and its base is positive. Transistor  $Q2$  saturates when its collector has a negative voltage and its base is negative. The two transformer secondaries must be in phase as shown by the small dots at terminals 1 and 3.

The circuit is equivalent to an exclusive OR logic device, which has an output only when the two inputs are at different levels. The high or low signal requirements are provided by the transistor being tested and the instantaneous polarity of the ac line at the moment. The combination is one polarity for npn transistors and the opposite polarity for pnp types.

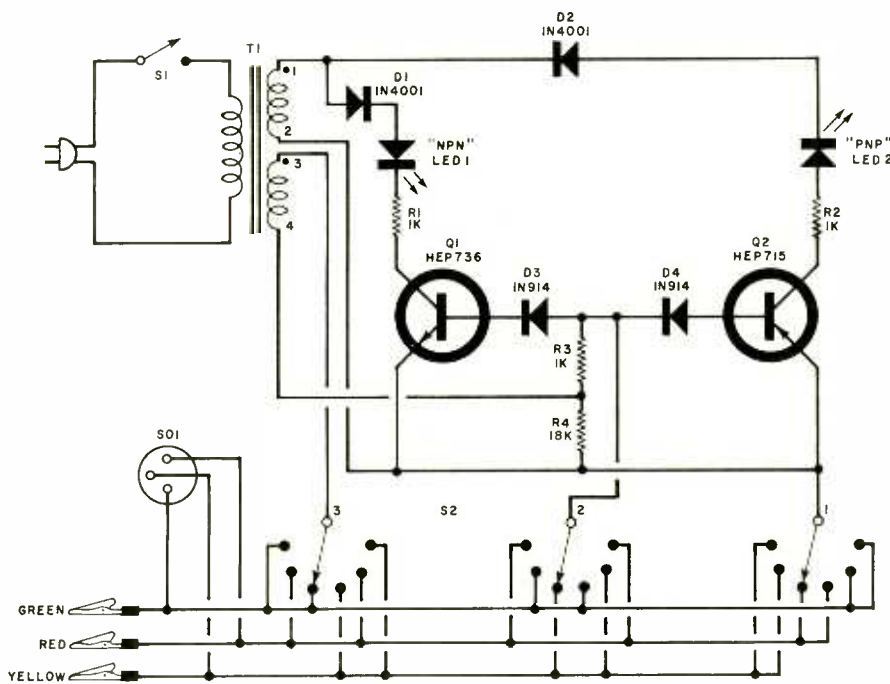

## PARTS LISTS

- D1, D2—1N4001 diode
- D3, D4—1N914 diode
- LED1, LED2—Light-emitting diode (Calec-tro K4-559 or similar)
- Q1—HEP736 transistor
- Q2—HEP715 transistor
- R1-R3—1000-ohm, ½-watt resistor
- R4—18,000-ohm, ½-watt resistor
- S1—Spst switch
- S2—3-pole, 6-position rotary switch (Mal-lory 3236J or similar)
- SO1—Molded transistor socket
- T1—12-volt, 300-mA filament transformer (Radio Shack 273-1385, modified per text)
- Misc.—Plastic case (Radio Shack 270-231), Insulated miniature alligator clips (red, green, and yellow; Radio Shack 270-378), knob with pointer, line cord, mounting hardware, press-on type, etc.

Fig. 1. Transistor being tested is plugged into SO1 or connected to color-coded alligator clips.

This distinction provides the type identification.

With the correct phasing of the 3-4 secondary of *T1*, the exclusive OR signals are accepted by the LED driver that can react to a compatible signal during its half cycle of the ac. Diodes *D3* and *D4* prevent slight differences in the voltage levels from turning on the drivers.

**Construction.** To duplicate the pro-

totype and use the pc boards shown in Fig. 2, certain mechanical modifications must be made to two of the components. Transformer *T1* must have its four terminals cut to a size that can fit into the pc board. As shown in Fig. 3, two more tabs must be added to terminate a new winding. The molded plastic form of this transformer allows adding the two new terminals (3 and 4 on the schematic). The six terminals will

then be spaced three on each side, on ⅜-in. centers.

Wind 46 turns of #34 enamelled wire around the original core. There is enough room to do this, although it will take a little patience. Be sure that the new winding is wound in the same direction as the 12-volt winding already on the transformer to ensure correct phasing. (Don't scrape the enamel off the wire.) If you should wind the new secondary the wrong

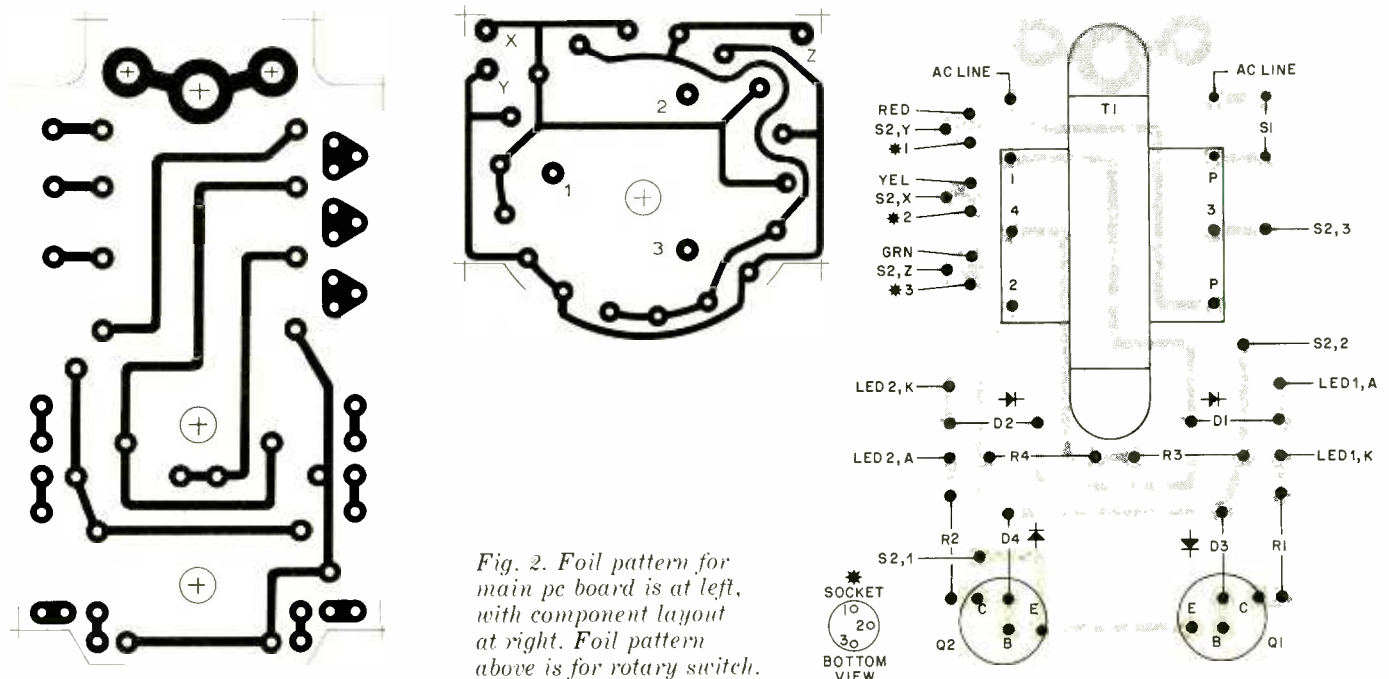

Fig. 2. Foil pattern for main pc board is at left, with component layout at right. Foil pattern above is for rotary switch.

way, it is easier to route the ends to the correct terminals than to start over or modify the pc board.

The terminals of S2 must be modified as shown in Fig. 3 so that the switch will fit the pc board as shown in Fig. 2.

Now you are ready to assemble the circuit on the main board as shown in Fig. 2. The front panel is marked as shown in the photograph with the six switch positions identified. Install SO1 and mount the LED's in small rubber grommets, properly identified.

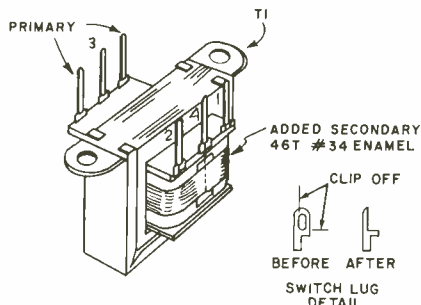

Fig. 3. Add a winding and terminals to the transformer and alter switch lugs as shown.

Then mount the switch on the front panel. Connect the larger board to it with spacers. Note that the large board has a small spacer supporting it from the hole drilled near the center of the rotary switch board.

Drill three small holes for the colored test leads and put grommets in the holes. The leads are terminated with color-coded insulated alligator clips. From the top of the panel, the lowest test lead (green) is on a line from the emitter terminal on SO1; the center lead (yellow) is the base; and the upper lead (red) is the collector.

**Operation.** Connect the three color-coded test leads to the unknown transistor in any order, turn on the power, and rotate S1 until one of the LED's illuminates. Make sure that this only occurs at one position. The position of the switch will then identify the leads and the LED will indicate the type.

If the transistor being tested is not good (either open, shorted or leaky), neither indicator may come on or one or both may light at more than one switch setting.

The Identometer will not check FET's, nor will it work "in circuit." When checking power transistors, particularly germanium types, there may be some unpredictable results due to the high leakage current associated with these transistors. ♦

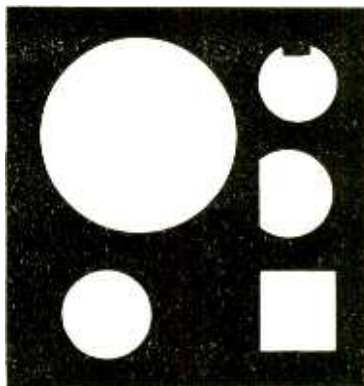

## Put more punch in your work.

With a Greenlee Chassis Punch you can punch clean, true holes in seconds. Round, square, key or D. In 16-ga. metal, hard rubber, plastic or epoxy. Available at radio and electronics parts dealers. Write for catalog E-730. Greenlee Tool Co, Rockford, Ill. 61101.

### GREENLEE TOOL CO

a subsidiary of

### Ex-Cell-O Corporation

CIRCLE NO 10 ON FREE INFORMATION CARD

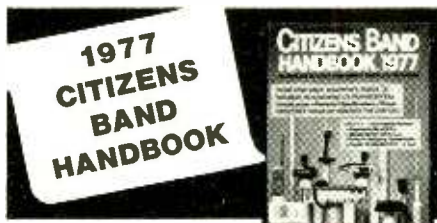

**CITIZENS BAND HANDBOOK**, by the editors of **POPULAR ELECTRONICS**, has it all . . . all the authoritative information you need on CB two-way radios to make an intelligent buying decision for transceivers, antennas and accessories. Here's a partial look at what the experts have packed into one volume.

- You'll have over 500 CB models at your fingertips, fully described with technical specifications, features, latest prices and photographs.
- The latest 40-channel CB transceivers, antennas and accessories are covered in detail.
- An expert evaluates new 40-channel CB radio power and performance.
- Manufacturers' specifications are "decoded" so anyone can read a "spec" sheet.
- What to look for when buying a transceiver.
- Mobile antenna types and performance judgments.
- How to sound like a CB pro when you're transmitting.
- Tips on eliminating ignition interference.
- How to prevent CB theft.

This packed-with-information Handbook is the CB publication you've been waiting for. Only \$1.95!

**CITIZEN'S BAND HANDBOOK**  
Consumer Service Division  
595 Broadway, N.Y., N.Y. 10012

EEH-78

Please send the 1977 **CITIZENS BAND HANDBOOK**. 1"m enclosing \$2.50.\* (\$1.95 plus 55c for postage and handling.) Outside U.S.A. \$3, postpaid.

Print Name \_\_\_\_\_

Address \_\_\_\_\_

City \_\_\_\_\_ State \_\_\_\_\_ Zip \_\_\_\_\_

\*Residents of CA, CO, FL, IL, MI, MO, NY STATE, DC and TX add applicable sales tax. (Postage and handling charges non-taxable.)

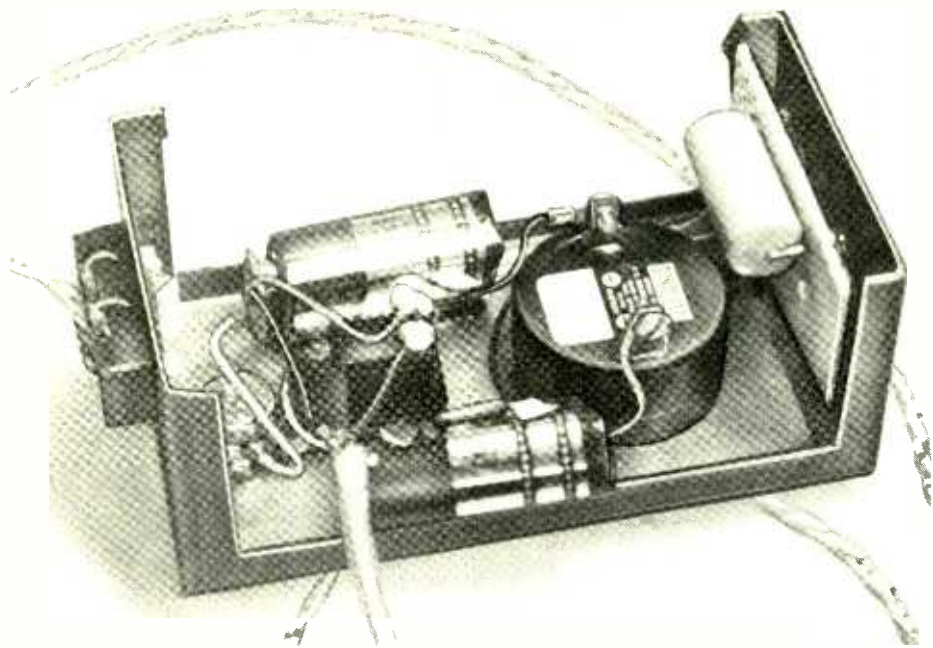

**Sounds alarm when freezer temperature rises above safe, preset value**

# HOME-FREEZER THAW ALARM Protects Food Investment

BY FRANKLIN C. WILLOUGHBY

**I**F YOU have a home freezer unit, you probably have a sizable investment in stored food. All that food can be lost if, for some reason, the temperature inside the freezer rises to the thaw point. For about \$15, you can build a thaw alarm to warn you of rising temperature long before the thaw point is reached.

The thaw alarm is adjustable over a temperature range of 0° F to room temperature. By adjusting it to trip at 10° F, the freezer can be opened to put in or take out food without triggering a false alarm.

The alarm's circuit (see schematic) is simple. Thermistor probe *TH1*, formed from two Fenwall Electronics GA41P2 10-kilohm thermistors in series (available from Allied Electronics as stock No. GA41P2, for \$3.95 each), goes into the freezer and serves as the temperature sensor. The temperature at which the alarm trips is governed by the setting of *R1*. Resistor *R2* is a gate current limiter for *SCR1* (the tripping device), while capacitor *C1* prevents transients from tripping the SCR when reset switch *S1* is operated. A Mallory No. SC628 Sonalert® is the "beeper."

Power for the circuit is provided by an

ordinary 9-volt battery (*B1*). Since current drain when the alarm is on standby is only 30  $\mu$ A, *B1*'s service life should be essentially the same as its shelf life. Even when the alarm trips, current consumption is still only 4 mA. To provide

Then back off just a bit until the alarm no longer sounds when *S1* is depressed and let go.

When you build the thaw alarm, carefully solder thin wires to *TH1*. Make these wires long enough to reach the cir-

*Thermistor probe, inside freezer, changes resistance with temperature to trigger SCR.*

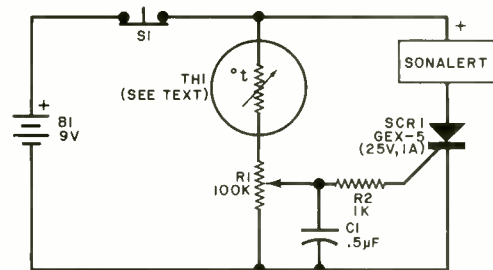

continuous, reliable protection, however, it is recommended that *B1* be replaced every six months or so.

Temperature adjustment, via *R1*, is made only after the probe, *TH1*, has been in the freezer for a half hour or so. Rotate *R1*'s knob slowly just to the point at which the Sonalert starts to beep.

cuit proper, located atop or somewhere near the freezer. After first insulating the soldered connections at *TH1*, slip a length of insulating tubing over the probe assembly. Pack both ends of the tubing with silicone rubber caulking compound. When the caulk sets, place the probe assembly in the freezer. ◇

# take a close look at PERIPHERAL VISION

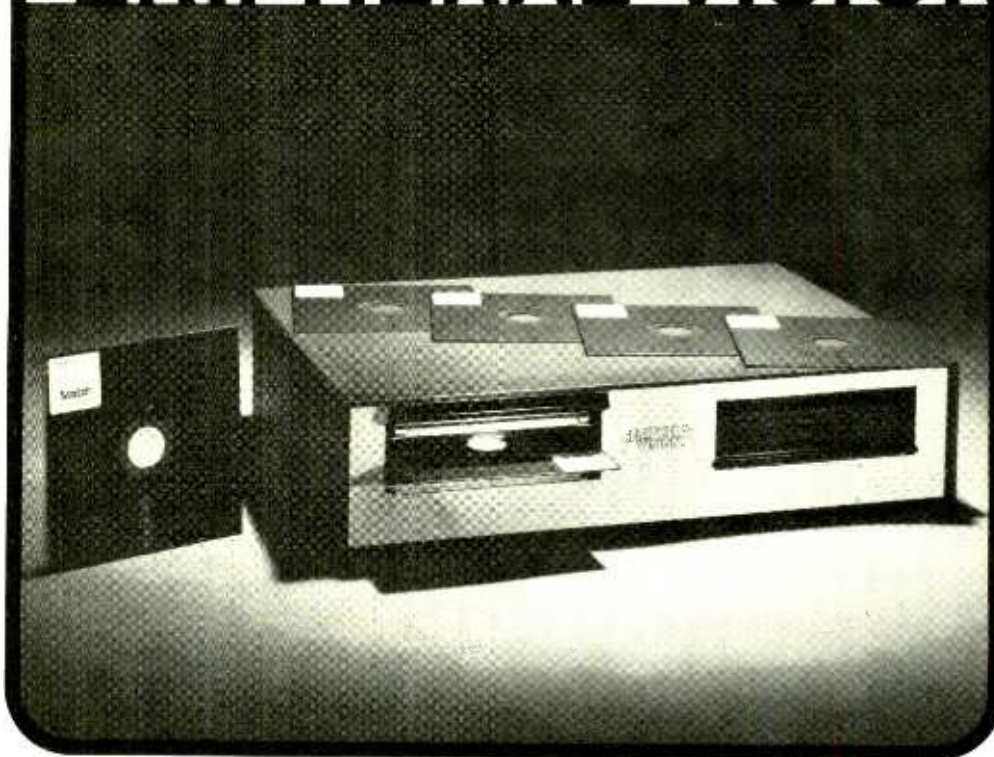

Peripheral Vision is a young, fast-moving company that's dedicated to selling reasonably priced peripherals for various manufacturers' CPU's.

So now, when you build your microcomputer system, you'll know where to look for all the peripherals that will make your system do what it's supposed to do.

Peripheral Vision may be young, but we have some old-fashioned ideas about how to run our business.

We know there are serious incompatibilities among the various manufacturers' peripherals and CPU's. We want to get them together. And we want to bring significant new products to market--products consisting of everything from adaptation instructions/kits for hardware and software to major new designs.

Most important to our customers, Peripheral Vision is committed to helping you get along with your computer. We'll do all we can to make it easy.

Our first product is a real reflection of this philosophy. It's a full-size floppy disk for the Altair-Imsai plug-in compatible S-100 BUS. And it's available for as low as \$750.00.

Our floppy disk has many exciting features:

- 1 interface card supports 4 or more drives
- Stores over 300,000 bytes per floppy
- Bootstrap EPROM included--no more toggling or paper tape

- Completely S-100 plug-in compatible
- Drive is from Innovex (the originator of the floppy concept)--assembled and tested
- Disk operating system with file management system included on floppy
- Cabinet and power supply optional

Also in the works are many new products we'll be letting you know about soon, if you'd like to take a closer look. Like I/O cards, tape drives, an impact printer--all for the S-100 BUS--and we're designing peripherals for a lot of other CPU's too.

We've given you a little glimpse of who we are and what we're doing. If you want to see more, just fill in the coupon below.

## PERIPHERAL VISION INC.

P.O. Box 6267/ Denver, Colorado 80206 303/777-4292

Name \_\_\_\_\_

Address \_\_\_\_\_

City/State/Zip \_\_\_\_\_

# HOME COMPUTER BASICS

BY LES SOLOMON

**D**URING the past couple of years, a new and fascinating hobby has sprung up—computers. Starting with a handful of computer “freaks,” the number of hobbyists has increased considerably and currently there are an estimated 26,000 hobby computers being used—or at least being played with.

If you wander into a computer store, or read computer-oriented articles in this and other publications, you may have trouble understanding, at first, just what’s going on. But once it’s all explained, the terms, at least, become easy to understand.

**What is a Computer?** Basically, a computer is a collection of electronic hardware that accepts data from the outside world, makes logical decisions based on this data and its stored instructions, manipulates the resulting data, and then outputs the results in a form that can be understood.

A computer system usually includes the computer itself and several “peripherals” used to communicate or store data and programs. The computer itself usually consists of the five hardware elements shown in Fig. 1—the microprocessor, memory, I/O (input-output) ports, clock, and power supply—all interconnected by an electro-mechanical “bus” structure. (But keep in mind that, although this article is hardware-oriented,

the best computer in the world cannot add 2 and 2 without suitable programs of “software”—just as the best software in the world is nothing but a piece of paper without the hardware to run it.)

**Microprocessor.** Sometimes called an MPU (microprocessing unit) or a CPU (central processing unit), this integrated circuit is the “brains” of the computer.

There are many types of processors, with the 8080, 6800, and 6502 (which were early starters, and thus have lots of software support) among the most popular. Each processor has some advantages over all the others, or there wouldn’t be so many.

The “power” of a processor is in its built-in instruction set. The more instructions and the more each can do, the more “powerful” the processor. The instruction set of each processor is unique to that particular type, and a “machine language” program written for one type will not work on another, as their instruction sets are not the same.

About the only exceptions are the 8080 and Z-80. The 8080 has 78 instructions. The newer Z-80 uses the 8080’s 78 instructions, plus 80 more. So most 8080 software will run on a Z-80, but because of the extra instructions, compatibility only goes one way.

A basic microprocessor is shown in Fig. 2. This single IC contains a variety of specialized circuits, too complex to cover in this article, but they follow the logic shown in Fig. 2.

Essentially, the MPU accepts the incoming data, processes it in accordance with the software-selected portions of the built-in instruction set, then passes the resulting data down the data bus along with the pertinent address requirements and control (sometimes called “handshake”) signals. Since each item connected to the bus structure has a unique address code, it, and only it can be turned on by the selected address and control signals and told what to do with the incoming data. For example, if the selected device is a block of memory, then it will either store or read the data. If it is an I/O (input/output) port then it will prepare the data for use by the pertinent terminal or receive data and instructions from that terminal.

**Memory.** When we speak of memory, we usually mean the solid-state memory devices that can be connected directly to the computer bus. (“Mass storage” memory devices, such as floppy disks and cassettes, will be discussed under “Peripherals.”)

Since all digital data consists of combinations of binary 1’s and 0’s, such data can be stored within groups of flip-flops

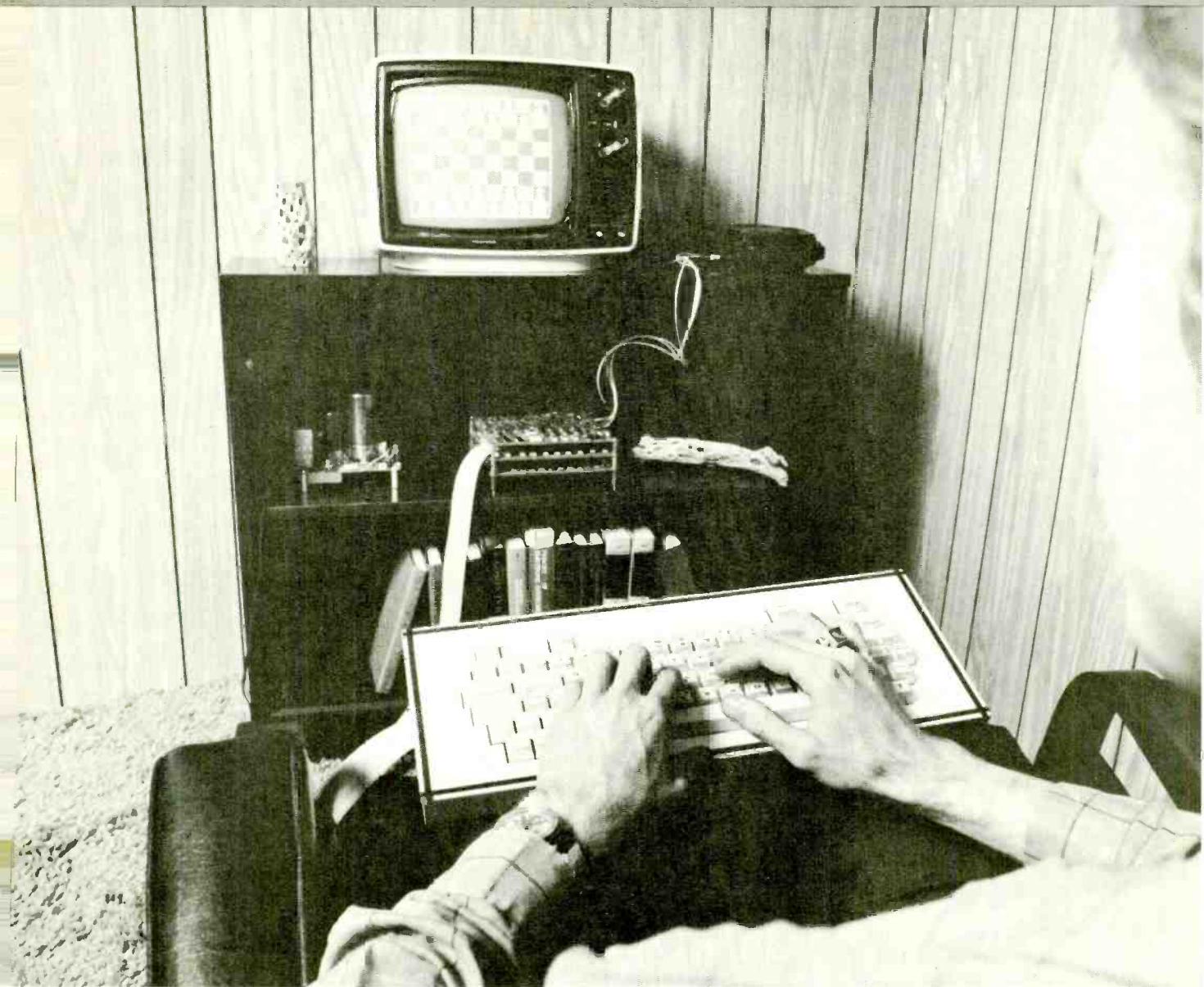

(which have two stable states, called, interestingly enough, "1" and "0"). Each discrete 1 or 0 is called a "bit," and data within a hobby computer is usually in "words" 8 bits (or 1 byte) long, although there are also hobby computers using 12-bit and 4-bit "words." (A computer "word," though, is much shorter than a human one, since it takes at least 7 bits to store a letter of the alphabet. Even a 12-bit word can store only a single alphabetic letter.) Most hobby computers can use a total of up to 65,536 bytes (usually abbreviated to "65k"). These 65k bytes can be made up of two types of memory, RAM and ROM, in any desired combination.

**RAM.** An abbreviation for Random-Access Memory, this IC contains a large number of flip-flops arranged so that a computer can "address" any block of flip-flops within the chip. During the

"write" cycle, the selected block can be set up with a particular digital combination to be stored, and during the "read" cycle, those selected bytes can be read out of the RAM—usually without destroying the data held in the RAM.

There are two types of RAM—static and dynamic. Static RAMs use conventional flip-flops that will remain in the set-up state (as determined by the program) as long as their operating d.c. power is applied. They change states only when told to by another write signal.

Dynamic RAMs also use flip-flops, but with a difference. Once the flip-flops have been set up as desired, they will remain in that state only as long as a tiny capacitor within each flip-flop remains charged. To maintain the stored data, the charges in these tiny capacitors must be "refreshed" from time to time. If the refresh stops, the capacitors discharge and the flip-flops can assume

random states and thus lose the data. Dynamic RAMs are faster than static RAMs and usually do not require as much operating power. The "payment" for this is that the processor (or some other circuit) must take time out to perform the refresh.

Both types of RAM are "volatile"; that is, the flip-flops will remain in the selected states only as long as operating d.c. power is applied to the chip. When this d.c. is removed, the flip-flops can assume a random state and lose data. Some RAM memory boards include a battery backup to maintain data in the event of a momentary power failure.

**ROM.** The other type of memory chip is called a ROM—for Read-Only Memory. In a way, a ROM can be thought of as a RAM whose flip-flops are made to assume a particular state, when "fixed" so that they cannot change states, even

when the operating d.c. power is removed. Since programs are called "software" and the electronic components "hardware," software (programs) in a ROM are called "firmware."

ROMs are used to hold programs or data that the computer will need nearly every time it's used. Usually these programs include "monitors" or "operating systems" that tell the computer how to communicate with terminals or other peripherals; sometimes they contain just "bootstrap" programs which tell the computer how to load in a monitor program from tape or—on the more complex side—a complete high-level language such as BASIC (more on that shortly); often, ROMs hold the special bit patterns that create the alphanumeric characters printed on a CRT or printing terminal.

There are several types of ROM. One is "burned" at the factory for a dedicated purpose, such as a character generator. Once created, such a ROM cannot be used for any other purpose.

But some ROMs are only semi-permanent. These include EROMs (Erasable ROM) or PROMs (Programmable ROMs) that can be programmed by the user (you can get reasonably priced PROM programmers for home use) then erased. Once a bit pattern has been established, it will remain in the ROM, even when the operating d.c. power is removed.

Individual RAM or ROM IC's come as "so many bits by so many bits." For example, 256 × 8 means that 256 bytes of data can be stored in that device. These memory devices are usually used in blocks and mounted on a single PC board, called a "memory board." You can purchase these as 4k (actually binary 4096), 8k (8192), 16k (16,384) or as larger modules in either kit or wired form. ROM boards are more expensive, when you add in the cost of the ROMs (they're usually extra), and usually come in 1k, 2k, and 4k sizes.

**I/O Ports.** The Input/Output ports are used to establish communication between the computer and the outside world.

As with memories, there are several different types. A *serial port* inputs or outputs data one bit at a time (digital Indian file), because many devices (the teletypewriter and some CRT terminals) require serial data. Special circuits within the port convert the normally parallel data within the computer into serial form. The speed of serial data movement is called "baud rate," expressed in bits per

second. Because it is an electro-mechanical device, a teletypewriter uses a slow 110-baud rate, where an electronic CRT terminal can go up to 19,200 baud.

There are two types of serial I/O; one is called a "current loop" because data flow makes and breaks a current (usually 20-mA) flow between the port and the terminal (usually a teletypewriter); the other, called "RS-232," uses a voltage that swings between a positive (1) level and a negative (0) level.

A *parallel port* "looks" at the entire 8-bit data byte at one time and delivers (or accepts) data in full bytes, at a speed determined by the computer. A special "handshake" signal keeps this port in step with the computer. Obviously, this approach is far faster than even the high baud rates used for serial data. Parallel ports are commonly used for keyboards and for paper-tape readers or punches.

A newcomer is the A/D (analog-to-digital) converter port. This approach is used to interface analog (linearly changing) signals with the high-speed digital computer. The most popular use by the hobbyist is for "joystick" controls for moving patterns around a CRT monitor, as in game playing.

**Clock.** Because a computer uses lots of digital circuits, some means must be found to keep all of them in step to avoid chaos. This is the purpose of the clock, usually a crystal-controlled oscillator. The clock signal is passed down the bus to all elements but the power supply.

**Power Supply.** Usually this is a well-regulated, conventional d.c. power source that supplies the various operating voltages at the required currents to all devices coupled to the bus.

**Bus Structure.** Essentially, the bus consists of a number of conductors—

usually copper traces on a large PC board, with "plug-in" connectors attached at intervals. This allows various additional module boards to be plugged in anywhere along the bus.

Although quite a few computers have their own bus system, the most common one is the "Altair" bus, invented by MITS for use in the original "Altair" computer (some manufacturers call it the "S-100" bus, because there are 100 pins on each bus connector). There are, currently available, over 150 modules, from about 40 manufacturers, that can plug directly into this bus. The Motorola EX-ORcisor and SWTP 6800 busses are also supported by products of more than one manufacturer, but not to the same degree.

**Modules and Expansion.** The great advantage of a bus system is that many devices can be designed to "plug into the bus," and thus expand the computer's versatility. Most of these plug-in modules are RAM and ROM memory boards of all sizes and speeds. Among the many dozens of plug-ins currently available, you will find such useful ones as cassette interfaces, video display modules, multi-port boards, and even a vocal input that enables the user to speak to his computer.

Cassette interfaces generate audio tones (usually one frequency for each "0" and another for each "1") to allow inexpensive audio recorders to store digital data. The playback system converts these tones back into "0's" and "1's," to load the data back into the computer. (Incidentally, a modem—short for *modulator-demodulator*—used for digital communications over telephone lines, works much the same way.)

Unfortunately, there are many "standards" governing the choice of frequencies and data transmission rate, such as the Kansas-City standard, Tarbell stand-

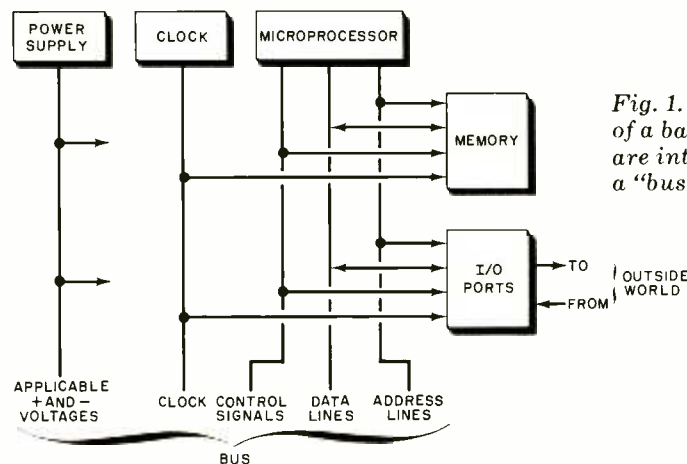

Fig. 1. Five elements of a basic computer are interconnected by a "bus" structure.



ard, and several used only by one company apiece (such as MIT's ACR and Processor Technology's CUTS). Recordings made on one system will be meaningless to a computer set up for another; you must always make sure that any recordings you get are compatible with the system you have.

Video display modules are used when you want to see your computer's output on a TV-like CRT screen, without going to the expense of a complete terminal (see "Peripherals"). The screen can belong to a CRT monitor (like a TV set without a tuner) specifically designed for computer or closed-circuit TV use, or it can be part of a conventional TV set, either converted for direct video input (not recommended for the beginner), or hooked up through an FCC-approved RF modulator. In this latter approach, the modulator is connected directly to the antenna terminals of a conventional TV receiver, and the receiver tuned to a locally unused channel, as is done with the very popular video games.

Since most computers come with only one I/O port, and many hobbyists like to connect various devices to their computers, the multi-port plug-in board was born. These boards can contain up to a half a dozen I/O ports, each capable of

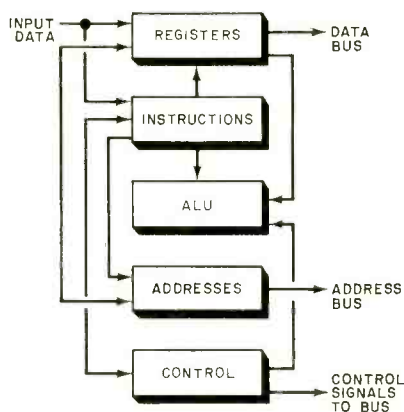

Fig. 2. Logic diagram of a basic microprocessor.

supporting its own output device.

The vocal input, which is the latest in peripherals that plug into a bus, was described in the May 1977 issue of POPULAR ELECTRONICS and the reader is referred to that issue for all details.

**Languages.** There are several ways to program a computer; but as far as the computer is concerned, there's just one way—binary machine code. Many computers let you enter the necessary 8-

digit strings of 1's and 0's directly; others have conversion routines in their ROM monitors that let you enter the instructions as 2-digit or 3-digit numbers, which is simpler. Simpler still is to use "assembly language," in which you enter the instructions in easily remembered mnemonic abbreviations (HLT means "halt," for example), which a moderately lengthy program (the "assembler") translates into the equivalent binary codes.

Machine-code and assembly-language programming both require that you learn to do things the computer's way. To add 2 and 2, for instance, you might tell the computer to load 2 into one register, to load the other 2 into another register, to add the two figures together and store the result, and then to output that result some place where you can see it. It would be simpler if you could just say "PRINT 2 + 2" and get results.

High-level languages, such as BASIC (the most common language in hobby computing), APL, COBOL, FORTRAN, and so on let you do just that; they feed the computer whole binary-instruction chains in response to a single symbol or English word of instruction. Also, where machine-code and assembly-language programs will only work on the MPUs

# ENTER THE WORLD OF

**EXPLORE  
INTERFACE AGE  
MAGAZINE**

- ★ READ INTERFACE AGE FOR THE LATEST ON NEW PRODUCT INFORMATION AND TECHNICAL BREAKTHROUGHS.
  - May's issue included inside the FLOPPY ROM™ — a vinyl record which is played on a conventional phonograph to enter this month's program in your computer.
- ★ ARTICLES RANGE FROM THE FUNDAMENTALS OF COMPUTERS TO LANGUAGES AND SYSTEM DESIGN. APPLICATIONS INCLUDE BOTH PROFESSIONAL AND NON-TECHNICAL.

# HOME AND SMALL BUSINESS COMPUTING

- ★ MONTH AFTER MONTH LOOK TO INTERFACE AGE MAGAZINE FOR THE LATEST INFORMATION ON THE DYNAMIC WORLD OF PERSONAL COMPUTING.
  - Use your personal computer for auto repair, work bench controller, teaching machine, central information bank and design test center.
  - Control your small business with your own real-time accounting and inventory control system.
  - Set your computer to turn sprinklers on and off, manage a household security system, even feed your dog.
  - Establish a recipe bank to plan daily meals and generate its own shopping list.
  - Evaluate the stock market, set up gambling and probability programs.

★ **ORDER YOUR SUBSCRIPTION NOW!**

12 Monthly Issues: \$14 U.S., \$16 Canada/Mexico, \$24 International

Name \_\_\_\_\_

Address \_\_\_\_\_

City \_\_\_\_\_ State \_\_\_\_\_ Zip \_\_\_\_\_

Check or M.O. (U.S. funds drawn on U.S. bank)  Visa Card  M/C

Acct. No. \_\_\_\_\_ Exp. Date \_\_\_\_\_

Signature \_\_\_\_\_

Make checks payable to:  
**INTERFACE AGE Magazine, P.O. Box 1234, Cerritos, CA 90701**

they were written for, BASIC and other high-level language programs can run on any machine programmed with that language. Minor changes may be necessary, since there are several slightly different versions of BASIC; but these changes are easily learned.

**Peripherals.** To use such languages, a computer must have a means of entering long assembler and high-level language programs, storing them when its power is off, a means of entering and storing the user's own programs, and a means of seeing the computer's output. Few computers have all of these facilities built-in—but all computers allow the use of *peripheral* equipment for these and other purposes.

**Terminals.** The easiest way to communicate with a computer is via a typewriter-like keyboard with the computer's output visible on a CRT screen or on paper. If the computer has a video interface built-in, a separate keyboard is the only thing which need be added. If not, it takes a CRT terminal or printing terminal (Teletypes are popular for this) containing keyboard and output. CRT terminals are faster, quieter, and don't waste paper; printing terminals leave a perma-

nent record, which is helpful in debugging programs and in using the computer's output. Elaborate systems may have both a CRT terminal for quick communication between operator and computer and a separate printer which can be switched in when required.

**Mass Storage.** Long programs like assemblers and BASIC interpreters can be entered from the keyboard; but since it can take about 6000 keystrokes to load an assembler and 24,000 strokes to enter an interpreter—plus the time needed to search back and find where the inevitable errors crept in—this is hardly practical, especially for programs which are used frequently. Most such programs are therefore delivered on either punched paper tape, audio cassettes, or magnetic floppy disks, which can be read into the machine in minutes or seconds. But to read them in requires a paper-tape reader, an audio cassette recorder and interface, or a floppy-disk system, all of which are available for microcomputers. Both audio cassettes and floppy disks allow the user's own programs to be recorded and stored for future use, too; programs can be stored on paper tape as well, but paper-tape punches are slow and noisy and (unless

built into a Teletype) expensive, so they're less frequently used in home systems. Cassette systems are reasonably fast, can hold quite a lot, and cost comparatively little, so they're the most popular. Floppy disks have the advantage of faster access (the disk's playback head can zip across the disk to get to an inside track, while a cassette's whole tape must be wound past the head to get at the last part of the recording), but disk (or diskette) systems are expensive. Between these stand *mini-floppy* disk systems, using smaller, lower-capacity disks (about one-third the capacity at about half to two-thirds the system price), and digital cassette units whose tape movements, controlled by the computer, can be quite rapid.

**Conclusion.** After reading this brief introduction to hobby computing, we hope that the reader has gained some understanding of this new and exciting hobby. If the interest has been fanned—what is the next step?

Scattered about the country (and in many overseas areas) are several hundred "computer stores" and computer clubs (see listing elsewhere). Drop in on the stores, speak to the employees, pick up some free brochures and read. ◇

**S.D. SALES CO. P.O. BOX 28810-EX DALLAS, TEXAS 75228**

## Imsai - Altair "A" Compatible Kits

Dealer inquiries welcome on these items:

Z-80 CPU BOARD FOR 4MHZ ADD \$10.00

4K LOW POWER RAM

FOR 250 NS ADD \$10.00

**Complete kit - \$149.**

The Whole Works **\$89.95**

**HARD TO FIND PROMS-RAMS-CPU'S-MICROPROCESSOR SUPPORT CHIPS-TTL-DTL-HLL(ITT SERIES 300) LINEAR-LEDS & LED DRIVERS (ITT SERIES 500)-PLUS A COMPLETE LOW POWER SCHOTTKY SERIES**

### RAM'S

21L02 - 500ns	8/12.95
21L02 - 250ns	8/15.95
2114 - 4K	14.95
1101A - 256	8/4.00

### CPU'S

Z-80 includes manual	39.95
Z-80A includes manual	44.95
8080A CPU	14.95
8008 CPU	6.95

### PROM'S

1702A - 1K	4.95-10/40.00
2708 - 8K	25.00
5204 - 4K	7.95
82S129 - 1K	2.50

### MICRO PROCESSOR SUPPORT CHIPS

8212 - I/O Port	3.50
8214 - P. I. C.	12.95
8216 - Non Invert Bus	4.95
8224 - Clock Gen.	4.95
8226 - Invert Bus	3.95

8228 Sys. Controller	8.20
8251 P.G.I.	14.30
8255 P.P.I.	13.50
8820 Dual Line Recr	1.75
8830 Dual Line Dr	1.75

8838 Quad Bus. Recr	2.00
74LS138N - 1/8 Decoder	.99
8T97 - Hex Tri St. Buf	1.25
1488/1489 - RS232	1.50
TR1602B Uart	6.95

CALL IN YOUR BANK  
AMERICARD (VISA) OR  
MASTERCARD OR  
ORDER IN ON OUR CON-  
TINENTAL UNITED  
STATES TOLL FREE  
WATTS LINE

TEXAS RESIDENTS CALL COLLECT

**214/271-0022**  
**1-800-527-3460**

**TERMS:**

**Money Back Guarantee!**  
NO COD'S. TEXAS RESIDENTS ADD 5% STATE  
SALES TAX. ADD 5% OF ORDER FOR POST-  
AGE & HANDLING. ORDERS UNDER \$10.00  
ADD 75c. FOREIGN ORDERS - U.S. FUNDS  
ONLY!

FOR ALL YOUR CONSTRUCTION AND ASSEMBLY NEEDS. WE'RE YOUR HEADQUARTERS FOR THE

HOBBYIST, EXPERIMENTER, AND THE PERSONAL COMPUTER FAN, OFFERING THE BEST PRICES AND GUARANTEED PARTS!

CIRCLE NO 21 ON FREE INFORMATION CARD

ELECTRONIC EXPERIMENTER'S HANDBOOK

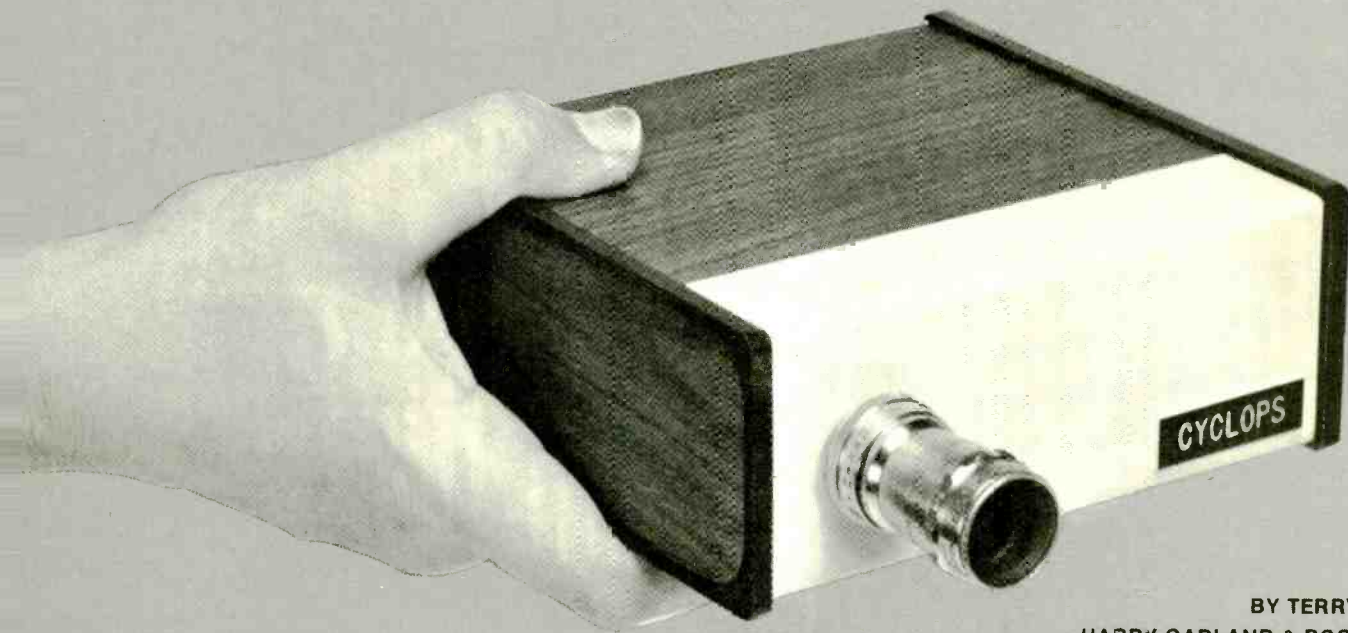

BY TERRY WALKER,  
HARRY GARLAND & ROGER MELEN

# BUILD CYCLOPS

## FIRST ALL SOLID-STATE TV CAMERA FOR EXPERIMENTERS

*Using an MOS array and digital electronics eliminates vidicon and yoke.*

**S**OLID-STATE image sensors may one day supplant vidicon tubes in TV cameras. They promise small size and easy camera construction, have a low power requirement and operate in a wide range of light conditions. Cost, however, has been prohibitive—until now!

Presented here is "Cyclops", the first all solid-state TV camera project using a special MOS photoelement array as the image sensor—and it can be built by electronics experimenters at an affordable price.

Any image that can be picked up by a conventional TV (or movie) camera can be picked up by Cyclops. Unlike conventional cameras, however, Cyclops is sensitive to infrared radiation and is thus able to "see" in the dark when an infrared light is used to illuminate the scene.

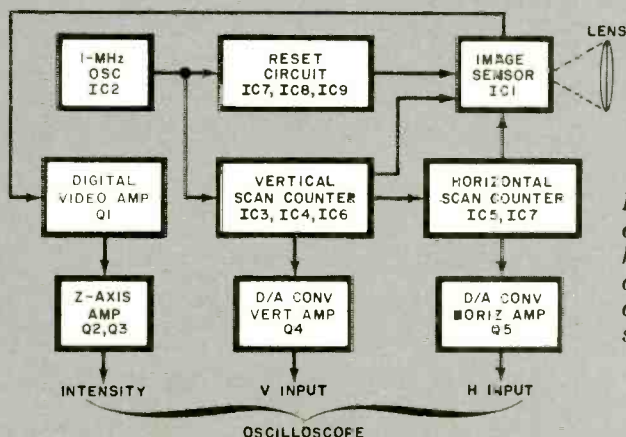

*Fig. 1. Logic diagram of the camera shows how scan counters address camera and also generate sweep signals for the scope.*

## PARTS LIST

- C1, C2—0.001- $\mu$ F disc capacitor  
 C3, C4, C5—0.1- $\mu$ F disc capacitor  
 C6—330-pF disc capacitor  
 C7, C8, C9—0.01 $\mu$ F disc capacitor  
 D1 to D4—1N914 diode  
 D5—1N5242 12-volt zener diode  
 IC1—1024-element image sensor  
 IC2, IC9—7402 TTL quadruple 2-input NOR gate  
 IC3, IC5, IC6, IC7—7493 TTL 4-bit binary counter  
 IC4—7404 TTL hex inverter  
 IC8—7400 TTL quadruple 2-input NAND gate  
 IC10—MC7805CP 5-volt regulator  
 I1, I2—#47 pilot light  
 J1 to J4—Banana jacks  
 Q1, Q2, Q3—2N3640 transistor  
 Q4, Q5—2N3904 transistor  
 R1—100-ohm, 1/2-watt miniature potentiometer  
 R2—100-ohm, 1/2-watt resistor  
 R3—560-ohm, 1/4-watt resistor  
 R4 to R18 and R52—1000-ohm, 1/4-watt resistor  
 R19—15,000-ohm, 1/4-watt resistor  
 R20 to R31—20,000-ohm, 1/4-watt 5% resis.  
 R32 to R39—10,000-ohm, 1/4-watt 5% resis.  
 R40 to R44—100-ohm, 1/4-watt resistor  
 R45, R46—68,000-ohm, 1/4-watt resistor  
 R47, R48—5600-ohm, 1/4-watt resistor  
 R49—1800-ohm, 1/4-watt resistor  
 R50—18,000-ohm, 1/4-watt resistor  
 R51—2200-ohm, 1/4-watt resistor  
 Misc.—IC socket (9), 3/4" variable-length spacers, lens (see text), suitable chassis, mounting hardware, line cord, etc.

Note—The following is available from CRO-MEMCO, 2400 Charleston, Mountain View, CA 94043: Image sensor (C-1024) for \$50, postpaid. California residents, please add sufficient sales tax.

Fig. 2. Complete schematic of the camera. Letters between sections are merely for showing interconnections. Letters in circles are terminals for use with optional circuits.

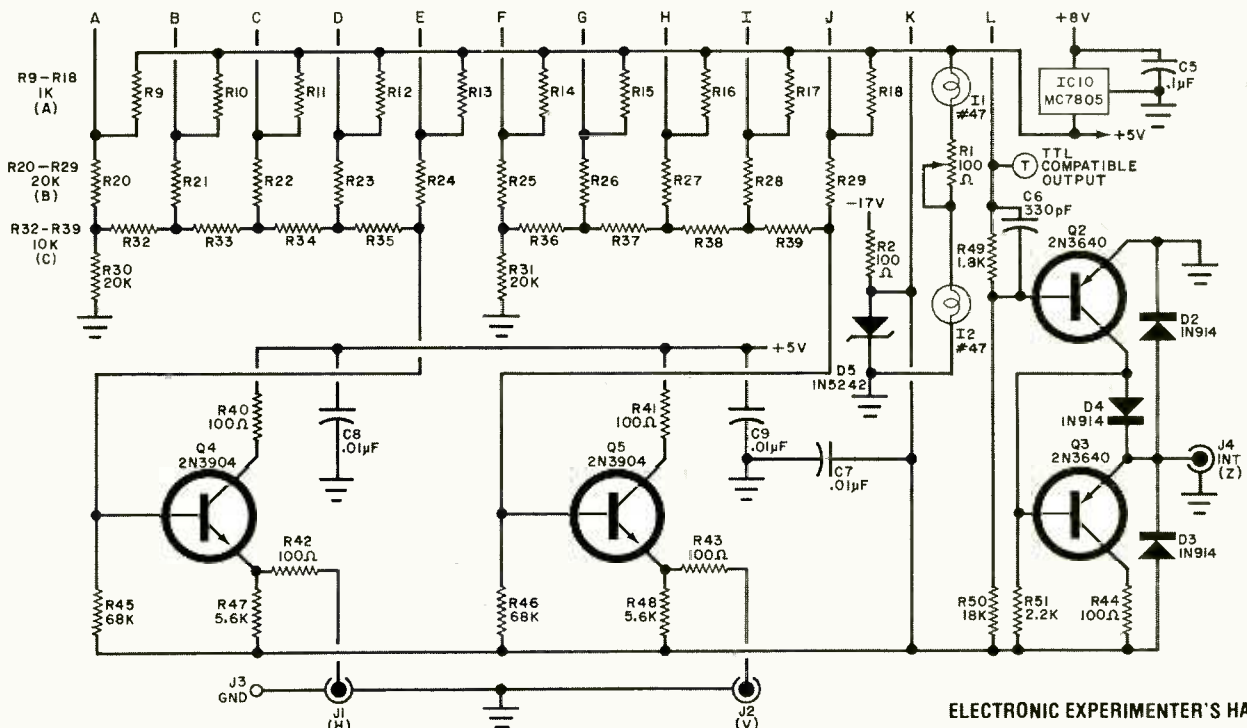
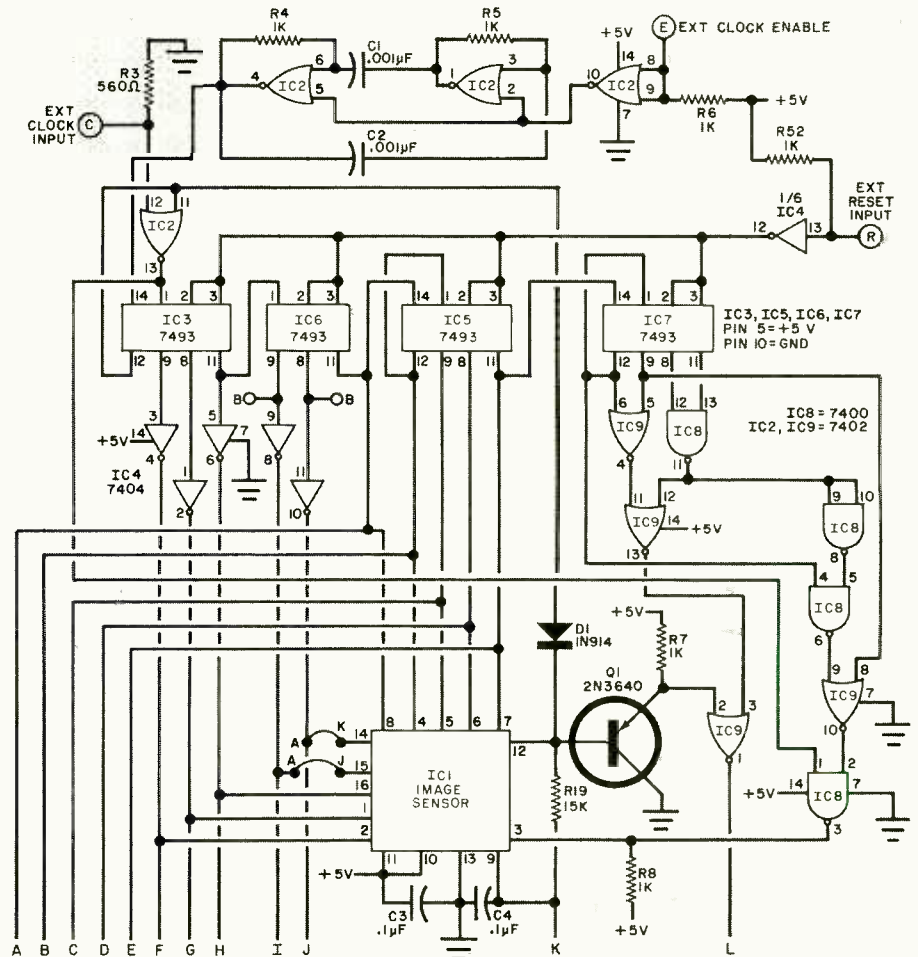

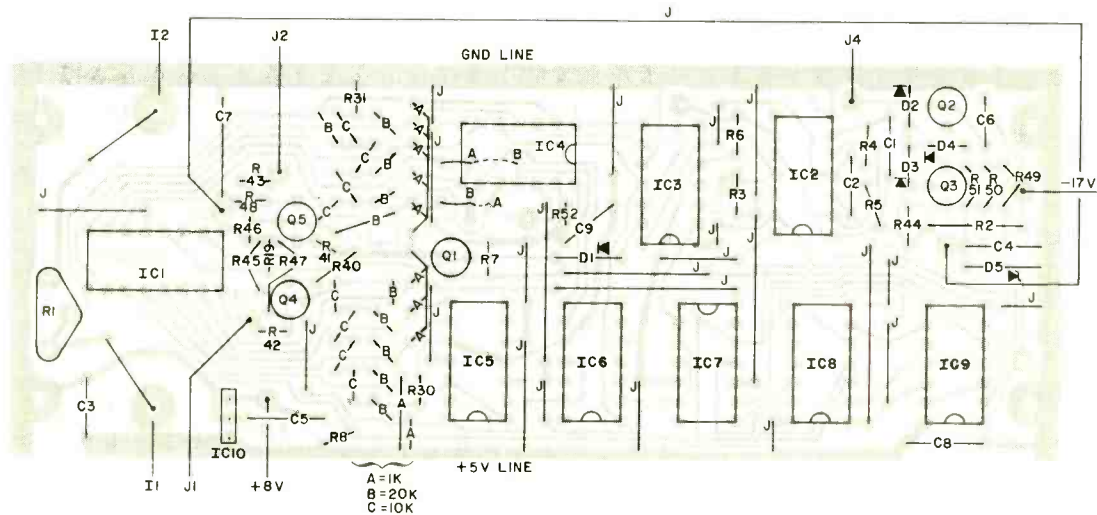
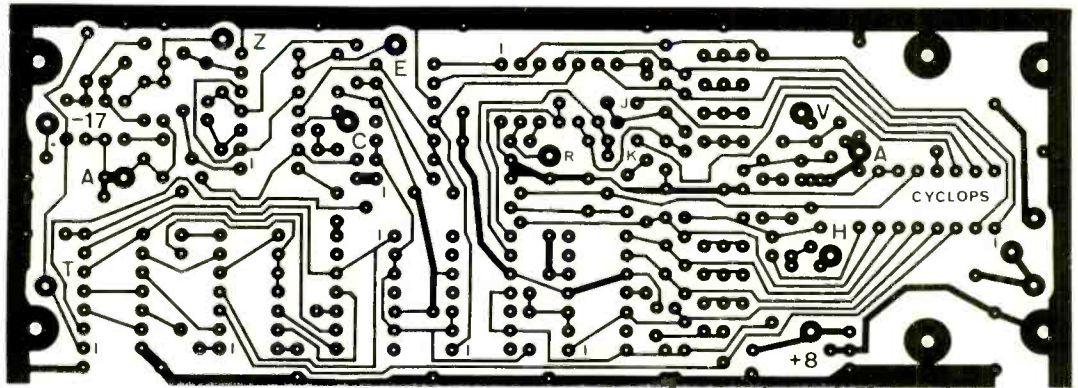

Fig. 3. Actual-size foil pattern (top) and component placement. Note that most resistors are mounted on end to conserve space.

The MOS array has 1024 separate photosensitive elements fabricated on a single chip and mounted in a conventional 16-pin DIP case with a transparent cover. Although similar sensing devices have cost up to several hundred dollars in the past, new techniques and volume production have made it possible to reduce prices. With just 1024 elements (in a 32 by 32 array), Cyclops can't be expected to match the resolution of a vidicon camera; but it is quite useful for many applications. The circuit described here is for using Cyclops with a conventional oscilloscope, but it could be altered for a display on a TV tube. (Among other things, a sync generator would be needed.)

A little imagination will enable the experimenter to come up with a number of novel uses for Cyclops. For example, if a fiber-optic light pipe is used with the sensor, it could pick up conventional printed material for transmission or to excite a type of tactile device for use by the blind. Consider also the possibility of using Cyclops in conjunction with the

Altair 8800 Minicomputer (POPULAR ELECTRONICS, January 1975). The combination could be used to build a security system that would operate on the basis of a person's appearance. This approach also opens up a brand new and exciting area for the advanced experimenter—a digital computer that has "vision." For example, the Cyclops/Altair combination, with 256 independent inputs/outputs could be the basis for a robot that could be programmed to do a number of things, while also being able to "see" its environment and make any necessary corrections in its actions.

**Circuit Operation.** The Cyclops logic diagram is shown in Fig. 1. A part of IC2 is used as a 1-MHz timing oscillator. One output of the oscillator drives the vertical scan counter, which drives the horizontal scan counter. The binary outputs of the scan counters are used to address the rows and columns of the MOS array.

As each of the 1024 elements is addressed, two events occur within a period of less than two microseconds.

First, the outputs of the vertical and horizontal scan counters are processed by a ladder-type digital-to-analog (D/A) converter, then amplified by Q4 and Q5, respectively, to produce the scope vertical and horizontal sweep. This creates the raster on the CRT. The second event occurs when the video information on the image sensor is read out, amplified and used to vary the brightness of each of the 1024 dots that make up the raster and produce the intensity-modulated image on the CRT. Since both sweeps (H and V) and the video (brightness) information are "in step" at all times, each of the 1024 elements on the sensor has a corresponding point on the raster, and the charge on each element determines the brightness of its raster dot.

A novel coding scheme is used for the video information. Thirty completely new frames are displayed on the scope each second, with each frame made up of 16 separate and complete scans of the image sensor. The first of these 16 scans is used to reset the 1024 photoelements, with

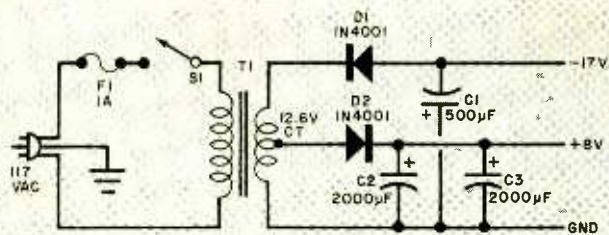

#### PARTS LIST

- |  |   |
|--|---|
| C1—500- $\mu$ F, 15-volt electrolytic capacitor      | F1—1-ampere fuse and holder                               |
| C2, C3—2000- $\mu$ F, 15-volt electrolytic capacitor | S1—Spst switch  |
| D1, D2—1N4001 diode                                  | T1—12.6-VCT filament transformer (Triad F-25X or similar) |

Fig. 4. Power supply for camera can be wired point-to-point and mounted anywhere in chassis.

the reset pulses generated by IC7, IC8, and IC9. On subsequent scans, the video information is read out.

When a particular photoelement is illuminated by a bright light (from the image being sensed), a video output pulse is developed each time that element is addressed. The video output pulses are amplified by Q1 and, after gating, by Q2 and Q3 to produce the scope intensity (Z) axis signal. If there is no light on a particular element, no video pulse is generated when that element is addressed. For grey portions of the picture, the number of video pulses generated for each frame is determined by the intensity of the grey in the original image.

Several inputs and outputs are provided on the pc board as shown in Fig. 2. These are for possible use in advanced projects. For normal operation, no connection is necessary at these points. Point "T" provides a TTL-level signal to facilitate interfacing with external digital circuits. By connecting point "E" to ground, the 1-MHz oscillator is disabled and an external oscillator can be applied to point "C". An external reset pulse can be applied through point "R" to reset the scan counters at any point in the scan cycle. Since both position and intensity information are available in digital form, Cyclops can very easily be interfaced with a digital computer.

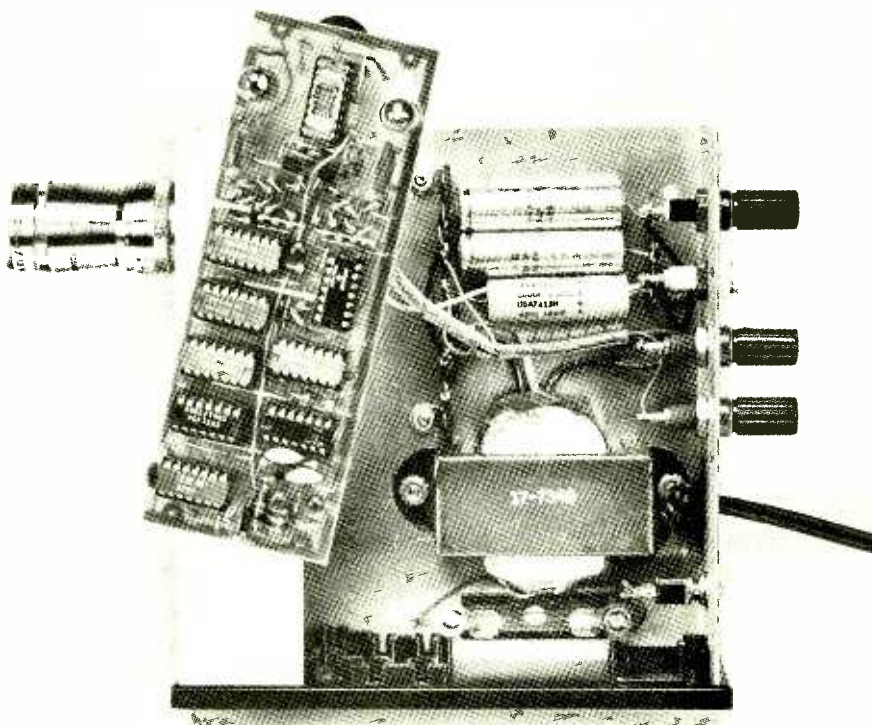

Photo shows chassis with the printed circuit board pulled out.

The external oscillator input can be used to synchronize Cyclops with the computer or with a TV display.

**Construction.** The logic circuits of Cyclops are on a single pc board (Fig. 3). Use sockets for all of the IC's except IC10 which is soldered in place. Be sure to observe the correct polarities on all IC's, diodes, and transistors.

For the pilot lamps (I1 and I2), drill holes in the board just large enough to accommodate the metal portions of the lamps so that, when they are inserted from the nonfoil side, the glass portion just touches the board. The metal portions of the lamps are then soldered to the pads, and small lengths of wire are soldered to the center connectors on the lamps and the appropriate pads.

Miniature potentiometer R1 is mounted on the foil side of the board so that the two lamps can be adjusted when the pc board is mounted in place. The purpose of I1 and I2 is to bias the image sensor with a dim, uniform background light. Although this is not absolutely necessary, the bias light improves the low-light-level sensitivity and provides better picture contrast.

Note that many resistors are mounted on-end to conserve space on the board.

The power supply circuit is shown in Fig. 4. This supply is wired point-to-point (using a terminal strip) and can be mounted anywhere within the selected chassis.

The pc board is mounted on 3/4" adjustable standoffs behind the front of the chassis. Mount the board temporarily and mark a spot on the front panel that is directly in line with the center of the image sensor (IC1). Remove the board and drill (or cut) a hole just large enough to accommodate the selected lens. Before mounting the board permanently, make sure that the distance between it and the lens can be adjusted slightly to permit focussing.

Connect the ground, +8-volt and -17-volt lines from the power supply to the board. Connect the four leads from the board (ground, vertical, horizontal, and intensity) to their respective color-coded jacks on the rear panel. The power switch (S1) is also mounted on the rear panel, and the line cord goes through a grommited hole in the same panel.

Either one of two image sensors

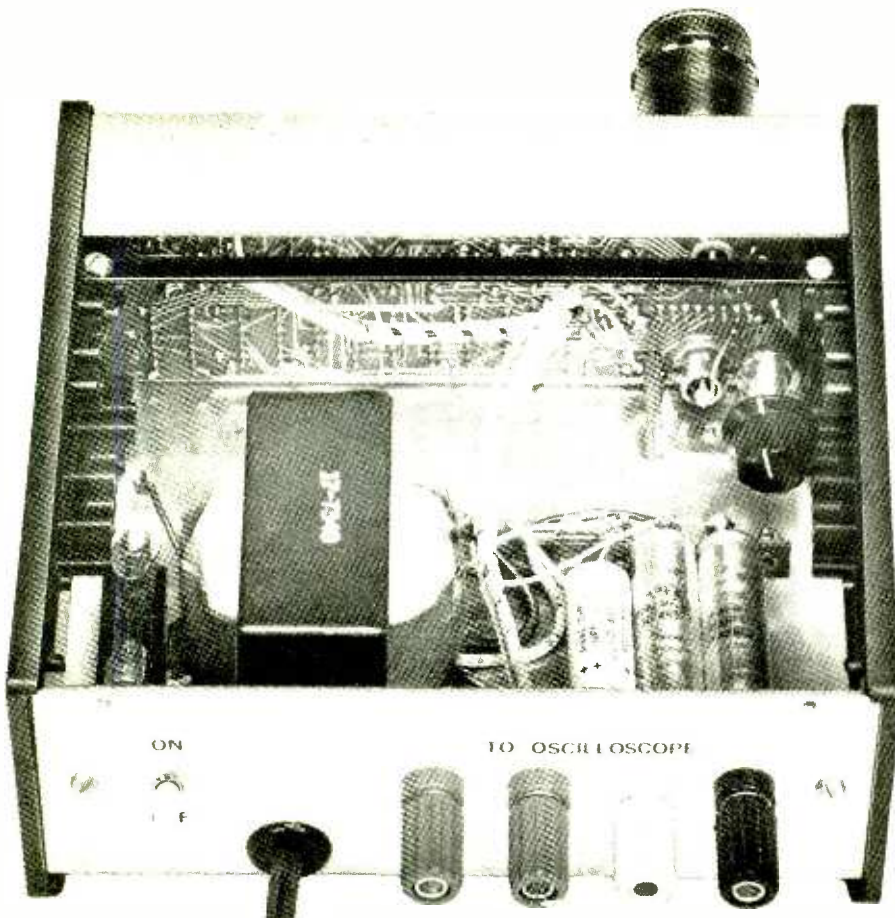

Jacks for scope connections and on/off switch are on chassis rear.

may be supplied for use in Cyclops. The two are identical except for the way pins 14 and 15 are connected to the circuit. Note that, on the pc board, IC1 pin 15 goes to pad J, and pin 14 goes to pad K. If your image sensor is marked "Type A," connect pad J to pin 8 of IC4 and pad K to pin 10 of IC4. If the image sensor is marked "Type B," connect pad J to pin 9 of IC4 and pad K to pin 11 of IC4.

**Lens Selection.** Almost any movie camera lens will work with Cyclops. The two important factors to consider in choosing a lens are focal length and

$f$ -number. The focal length determines the viewing angle of the camera, while the  $f$ -number determines how much light can be collected.

The lens used with Cyclops should have a variable aperture so that the  $f$ -number can be adjusted to suit the lighting conditions. The minimum  $f$ -number, when the aperture is wide open, determines the lowest light level at which Cyclops will operate. An  $f$ -2.8 lens should be adequate for most applications, though some additional lighting may be required for indoor operation. (We purchased an under-\$10 used  $f$ -2.8 normal motion-

picture-camera lens with variable stops for this project.)

Both new and used movie camera lenses are available from photography stores and mail-order houses. A 12.5-mm,  $f$ -27 lens is available from Edmund Scientific (300 Edscorp Bldg., Barrington, NJ 08007) for less than \$10 (stock No. 41,146).

**Setup and Operation.** Connect Cyclops to an oscilloscope (set to external horizontal) as follows: J1 to horizontal input, J2 to vertical input, J3 to ground, and J4 to intensity input. If your scope does not have provision for an intensity input, modify it according to Fig. 5.

With power applied to both Cyclops and the scope, adjust the scope's horizontal and vertical gain until a 32-by-32 pattern of dots forms a square array on the screen. Cover the lens of Cyclops and then turn the scope's intensity control down until the dots just disappear. Now, expose the lens to a lamp. The dots on the CRT will illuminate.

To adjust the focus between the image sensor and lens, turn the bias lamps down ( $R1$  at maximum resistance) and expose the lens to a simple, illuminated test pattern such as a black cross on a white background. If the lens can be focussed, adjust it for the distance between the lens and the test pattern. Set the lens to its widest opening (smallest  $f$ -number). Use a 50-watt lamp to illuminate the test pattern and position the lamp until an image appears on the screen. Adjust the distance between the image sensor and the lens by varying the spacers until the test pattern is in the sharpest focus. Then secure the pc board in place.

To adjust the bias lamps, darken the room so that no ambient light reaches the image sensor. Make sure that  $R1$  is at maximum resistance (lamps out). Adjust the scope's brightness control until the dot pattern can just be seen, and then increase the brightness of the bias lamps until the scope pattern just starts to get brighter. This is the correct setting of  $R1$ . Place the cover on the chassis so that no ambient light reaches the image sensor.

Cyclops is now ready for use. Although the resolution may seem to be on the low side for observing fine details, you will note that the apparent resolution seems to increase when viewing a "live" scene—especially one with motion. ♦

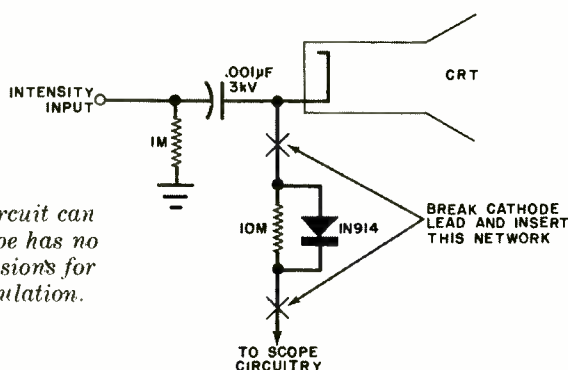
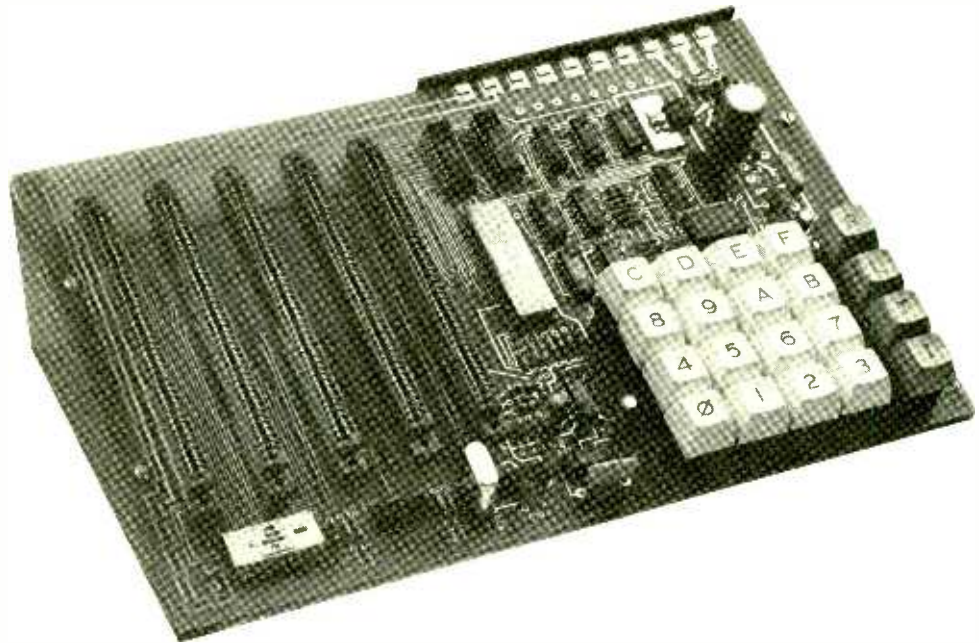

Fig. 5 This circuit can be used if scope has no internal provisions for intensity modulation.



# Build a PERSONAL MICROCOMPUTER FOR \$100

**T**HE COSMAC 1802 microprocessor can serve as the heart of a relatively inexpensive (about \$100) microcomputer trainer that also features powerful application and expansion capabilities. The microprocessor circuitry here can also serve admirably as the basis for a variety of control applications, such as a security system, electronic games, time delay control, sequential lighting, temperature sensing, and so on.

The basic computer—COSMAC ELF—was originally introduced as a perforated-board project last year in *POPULAR ELECTRONICS*, followed by a series of articles that introduced new features. Elf II, presented here, incorporates all these upgraded features plus new ones, as follows:

- \* Double-sided PC board.
- \* Hexadecimal keypad with associated logic.
- \* An 86-line bus for system expansion.
- \* Video graphics.
- \* Seven-segment LED readouts.
- \* 256 bytes of RAM.
- \* A.c. operation.

**The Basic Elf.** The basic computer circuit shown in Fig. 1, and the graphics interface shown in Fig. 2 are essentially the same as the original Elf's.

Whereas the original Elf used a pair of relatively expensive hexadecimal decoders/latch/readouts to monitor the data lines, Elf II uses a pair of conventional 7-segment LED displays to do the same thing. Besides the saving in cost, the only difference between the two approaches is that in the Elf-II method, lower-case 'b' and 'd' are used instead of capital letters. However, these cannot be mistaken for any other alphanumeric character. The new circuit is shown in Fig. 3. Integrated circuits A8 and A12 accept the digital information from the data bus—buffered by A7 and A11—and convert this data to drive the common-cathode 7-segment LED readouts forming *DIS1*. Besides the data information, this circuit also accepts the strobe signal coming from A5 of Fig. 1 (the original IC10, pin 9).

The original Elf used eight discrete toggle switches to insert data. In contrast, Elf II incorporates a calculator-type hexadecimal keypad, which is much simpler to work with.

As shown in Fig. 4, the calculator-type hex keypad contains normally open/momentary close spst switches in the matrix. The keypad is decoded by A10, which features a 2-key rollover. The output of A10 is used to drive data bus driv-

er A3, and at the same time also drive A9. The latter drives data bus driver A4. Keyboard decoder A10 contains its own internal oscillator (used to sample the keys); its frequency is determined by the external passive components.

The "front panel" circuit is shown in Fig. 5. The RUN (S4), LOAD (S3), and MEMORY PROTECT (S2) switches can be locked in either the on (down) or off (up) positions. To use these switches, simply depress to turn on; and depress again to unlock and turn off.

**Bus.** The Elf-II has been provided with an 86-line (twin 43) bus structure to carry the signals shown in Fig. 6. Note that at this time, only the even-numbered connections are used, excepting pins 1 and 3 which carry the +5-volt supply. All of the 1802 signals are present on this bus, which includes the system +5-volts, ground, and the 3.58-MHz signal from the video clock. Any connections made to this bus must be buffered if a CMOS device is not used.

The use of this bus, not present in the original Elf design, will allow easy system expansion for added memory, I/O ports, cassette or printer interface, ROM operating system, or an alphanumeric keyboard.



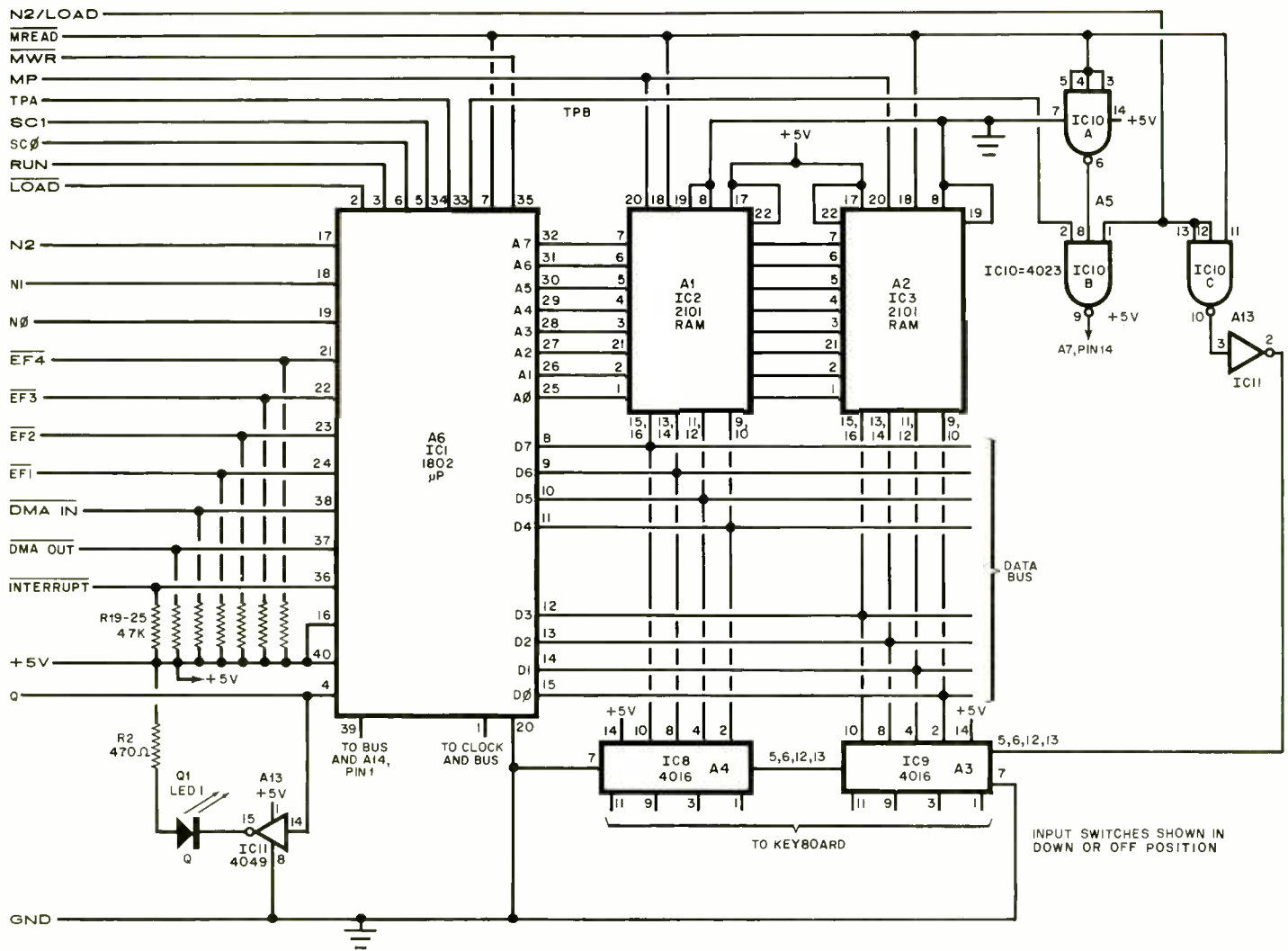

Fig. 1. The basic Elf circuit is modified as shown here. Note that the IC's are now A-prefixed, and the passive components are renumbered.

### PARTS LIST

- A1, A2—2101 (256x4) static RAM
- A3, A4—4026 quad bilateral switch
- A5—4023 triple 3-input NAND gate
- A6—1802 COSMAC microprocessor (RCA)
- A7, A11—4050 non-inverting hex buffer
- A8, A12—9368, 7-segment decoder/driver/latch (Fairchild)
- A9—74C173 latch
- A10—74C922 keyboard decoder with 2-key rollover
- A13—4049 inverting hex buffer
- A14—1861 video TV chip (RCA)
- A15—74L00 quad 2-input NAND gate
- A16—7474 dual-D flip-flop
- A17—4013 dual-D flip-flop
- A18—7805 5-volt regulator
- C1—10- $\mu$ F, 16-volt electrolytic capacitor
- C2—1000- $\mu$ F, 16-volt electrolytic capacitor
- C3—2.2- $\mu$ F, 16-volt electrolytic capacitor
- C4, C9—15- $\mu$ F Mylar capacitor
- C5, C7, C8—25- $\mu$ F, 16-volt electrolytic capacitor
- C6—not used
- C10—330-pF disc capacitor
- D1 through D4—1N4001
- D5 through D10—1N4148

- DIS1—NSN-373 dual 7-segment display (National)
- Q1—Red light emitting diode
- R1—optional dropping resistor if T1 output greater than 6.3-volts at 400 mA.
- The following resistors are 1/4-watt:
- R2, R31, R32—470-ohm
- R3, R27, R28—390-ohm
- R4 through R17—120-ohm
- R18—not used
- R19 through R26, R29—47,000-ohm
- S1, S5 through S20—spst momentary keypad switch
- S2, S3, S4—spst latching keypad switch
- T1—transformer, 6.3-volts, 400-mA
- XTAL—3.58-MHz color-TV crystal
- Misc—86-pin bus connectors (optional), 10-screw terminal strip, mounting rails and hardware, line cord, sockets for all IC's.
- Note—A complete kit for the Elf-II (except for T1) including double-sided pc board with plated-through holes is available from Netronics Ltd., 333 Litchfield Rd., New Milford, CT 06776 for \$99.50 plus \$3.00 postage and handling. COSMAC 1802 Users Manual \$5.50.

**Power Supply.** Elf II's power supply uses an on-board bridge rectifier and filter that drives the 5-volt regulator IC (A18). This permits the use of a conventional 6.3-volt, 400-mA transformer (which is mounted off the board). If you elect to use a higher-voltage transformer, a suitable dropping resistor (R1) must be placed in series between filter capacitor C2 and the input to the voltage regulator, as shown in Fig. 7. (The original Elf was battery powered.)

**Construction.** Elf-II is constructed on a double-sided pc board such as that shown in Fig. 8, along with the component placement. If desired, the system may be wire-wrapped using perforated board and wire-wrap sockets and component pins.

Observe the correct polarity when installing the electrolytic capacitors, LED (Q1), as well as the pin-1 identifiers on all the ICs. Sockets are suggested for all IC's. This is especially important for the two memory chips (A1 and A2) so that they can be easily removed when expanding the memory via the new bus.

The keypad switches are installed by

# AVANTI® HIGH PERFORMANCE C.B. ANTENNAS

40 CHANNEL ENGINEERED

## ASTRO PLANE™ CB Base Antenna Co-inductive

The omni-directional CB antenna that radiates from the top — for greater range and performance. 4.46 db gain over isotropic — stronger signal, clearer reception. No coils to burn or short. Vertical polarity. Patent #3587109  
Model AV-101...price \$39.95  
2.8x more power  
E.R.P

Avanti CB base antennas from \$20.50 to \$404.00



## RACER 27™ CB Mobile Antenna Magnetic mount

Easy to mount on roof or trunk for car, van or truck — no holes to drill — fast removal for hide away or car washing. Strong magnet assures position. Mylar pad guards vehicle finish

Hermi-coil (Hermetically sealed coil) — A special molding process provides a weather-proof coil environment. Helps maintain the characteristic antenna impedance, even in damp or salt water atmosphere. Hermi-coil also helps eliminate internal surface leakage.  
Ribbed base — Provides a long leakage path used in high voltage insulators, spark plugs, etc.

Specifications: Electrical 1/4 wave length  
• Unity gain • 27 MHz  
• V S W R — 1.3:1 or better  
• Coil — shunt fed hermi-coil

MODEL AV-727 Mobile Antenna System with 48" whip, 17' coaxial cable with magnetic mount, 40 channel \$32.95

Avanti makes a complete line of high performance mobile CB antenna systems from \$11.95 to \$72.50



FREE 24 PAGE CATALOG

# avanti

Avanti Research & Development, Inc.

Established 1964

340 Stewart Ave., Addison, IL 60101 USA

creators of the  
famous



© Copyright 1977  
All rights reserved

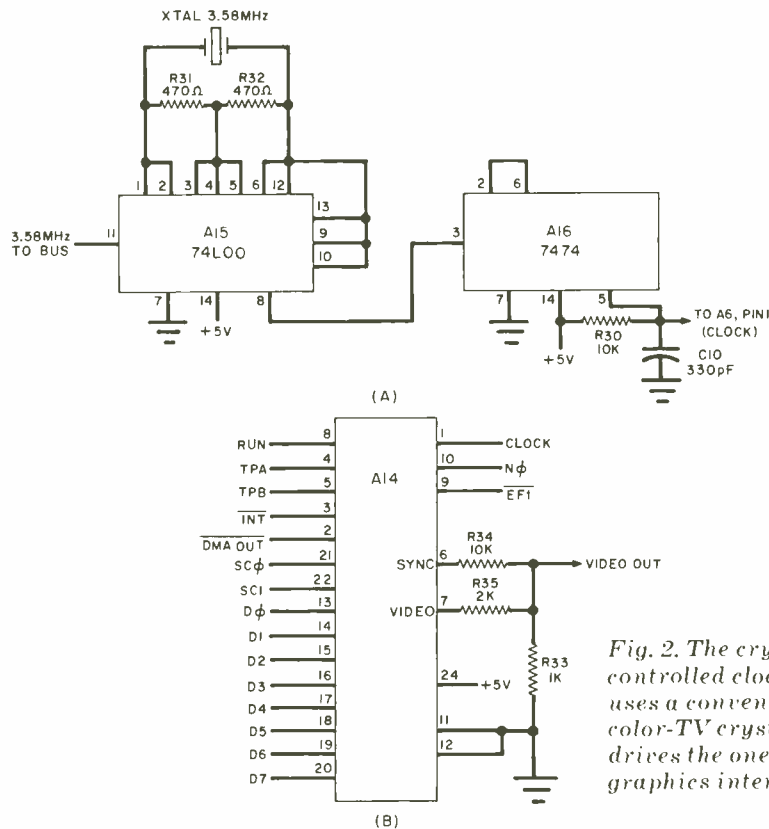

properly orienting them and inserting their plastic alignment pins in the appropriate holes at each switch position. The correct key placement is shown in the photograph. Make sure that the tops of all keys, including the control keys, are

the same height above the pc board before soldering the leads in place. Also be certain that the RUN, LOAD, and MEMORY PROTECT (P) switches can be locked down (on) or up (off) before soldering.

There are 10 solder pads along the

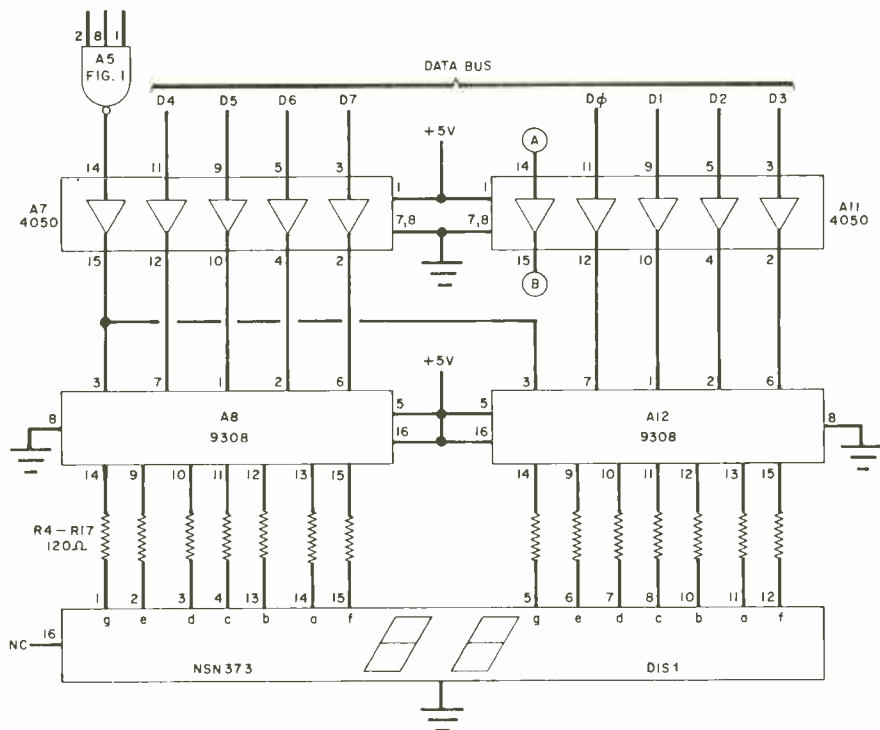

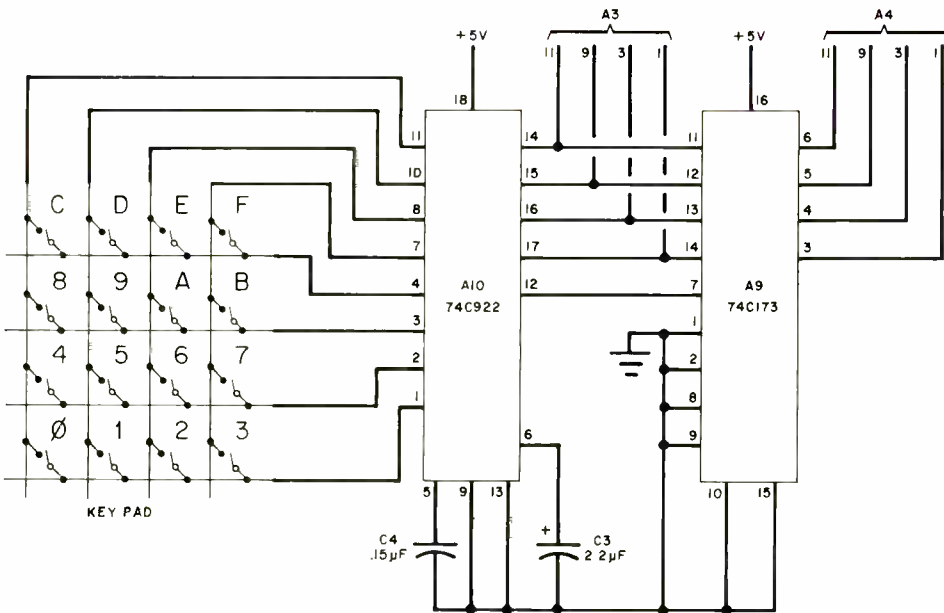

Fig. 4. Standard hex keypad works in conjunction with a keyboard decoder chip having a 2-key rollover.

upper right-hand corner of the board. The two rightmost pads accept the 6.3-volts ac from the off-board transformer, while the third pad is connected to an earth ground. The two leftmost pads are

for the video output, with the leftmost pad for ground and the pad next to it for carrying the video signal to be connected to the CRT monitor or converted television set.

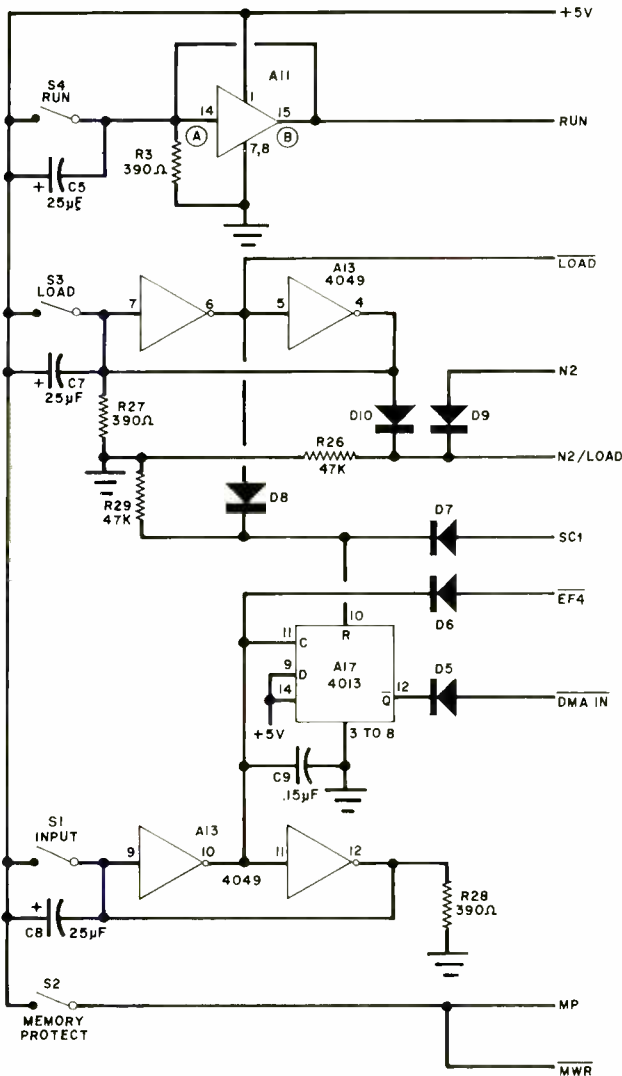

Fig. 5. Because the calculator-type control switches as spst, the original 'front panel' is slightly modified.

A mating clip-on connector strip is mounted to the pc board directly above the 10 pads, and tabs on the connector strip are soldered to the associated board pads. The other side of this terminal strip (the side away from the pc board) is fitted with screw connectors, for making external connections. After installing this strip, mount A18 (the 5-volt regulator) on a 1" x 3/4" x 1/4" thick aluminum strip positioned directly under the lug of the regulator.

Once wired, the board can then be se-

ELF Connector	Name	1802 pin #
2	+5 volts	—
4	+5 volts	—
6	clock	1
8	clock	39
10	LOAD	2
12	DMA IN	38
14	RUN	3
16	DMA OUT	37
18	Q	4
20	INT	36
22	SC1	5
24	MWR	35
26	SC0	6
28	TPA	34
30	MREAD	7
32	TPB	33
34	D7	8
36	A7	32
38	D6	9
40	A6	31
42	D5	10
44	A5	30
46	D4	11
48	A4	29
50	D3	12
52	A3	28
54	D2	13
56	A2	27
58	D1	14
60	A1	26
62	D0	15
64	A0	25
66	EF1	24
68	N2	17
70	EF2	23
72	N1	18
74	EF3	22
76	N0	19
78	EF4	21
80	GND	20
82	GND	20
84	not conn.	—
86	3.58 MHz	—

Note: Odd numbered pins on left side of connector (with the exception of pins 1 and 3 which are +5-volts) are not used at this time.

Fig. 6. The Elf-II bus structure enables easy system expansion.

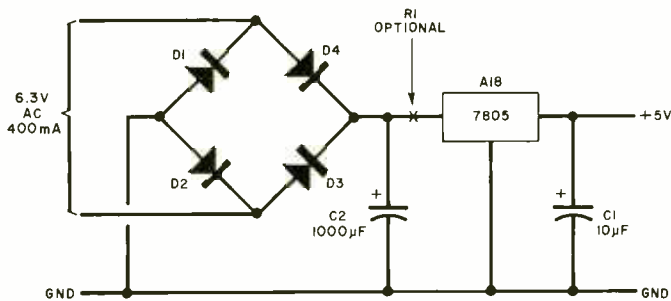

Fig. 7. The power supply, except for the transformer, is mounted on the Elf-II pc board.

### PROGRAM 1 Q-LED TEST

Memory Location	Data
0000	7A
0001	F8 10 B1
0004	21
0005	91
0006	3A 04
0008	31 00
000A	7B
000B	30 01

cured to a pair of wood side supports using suitable wood screws passed through the two holes on each of the narrow sides of the board. Once the board has been mounted and all the passive components and IC sockets are in place, the IC's have to be installed.

As many of the IC's are CMOS types, extra care must be taken in both handling and installing them. Hold the IC's by the case edges, not the pins. Keep one hand on the board foil pattern when installing the IC's to prevent static build-up, then install the IC's in their proper places using the component placement guide of Fig. 8. Make sure that you observe all pin-1 designators.

Other than installing bus connectors, the Elf-II should now be assembled and ready for testing. However, before turning on the power, recheck the board for correct installation of all components. Then check to see if there are short cir-

cuits between any closely spaced pc foil traces.

**Testing.** There are two tests that can be made to check Elf II operation. The first uses the flashing of the Q1 LED to check computer operation, while the second test checks out video operation.

Program 1, listed in an accompanying table, is the computer test. Before entering this program the Elf-II must be powered. To do this, connect the secondary of the 6.3-volt, 400-mA transformer to the two screw terminals at the right side of the 10-pad connector strip. Connect the primary of this transformer to the line power. When the Elf-II is powered, the two displays should indicate a random pair of hex digits. Make sure that the three control switches—RUN, LOAD, and P (memory protect) are all in their up (off) positions. Placing the LOAD switch in its down (locked) position auto-

matically causes the system to go to address 0000.

Release the LOAD switch and, using the hex keypad, touch the two keys associated with the first op code of Program 1. (This is 7A.) Then depress the INPUT key. The data (7A) will then appear on the two readouts. In the same manner, insert the remainder of Program 1 into the system.

When the complete program is in memory, move the LOAD switch back to its upper position. Then depress the RUN switch, which will lock down. You should observe that the single LED alongside the two 7-segment readouts will start to flash.

To test the graphics output, connect the CRT monitor to the two connector strip screws that carry the video output and ground (be sure that you connect ground to ground). DO NOT use any

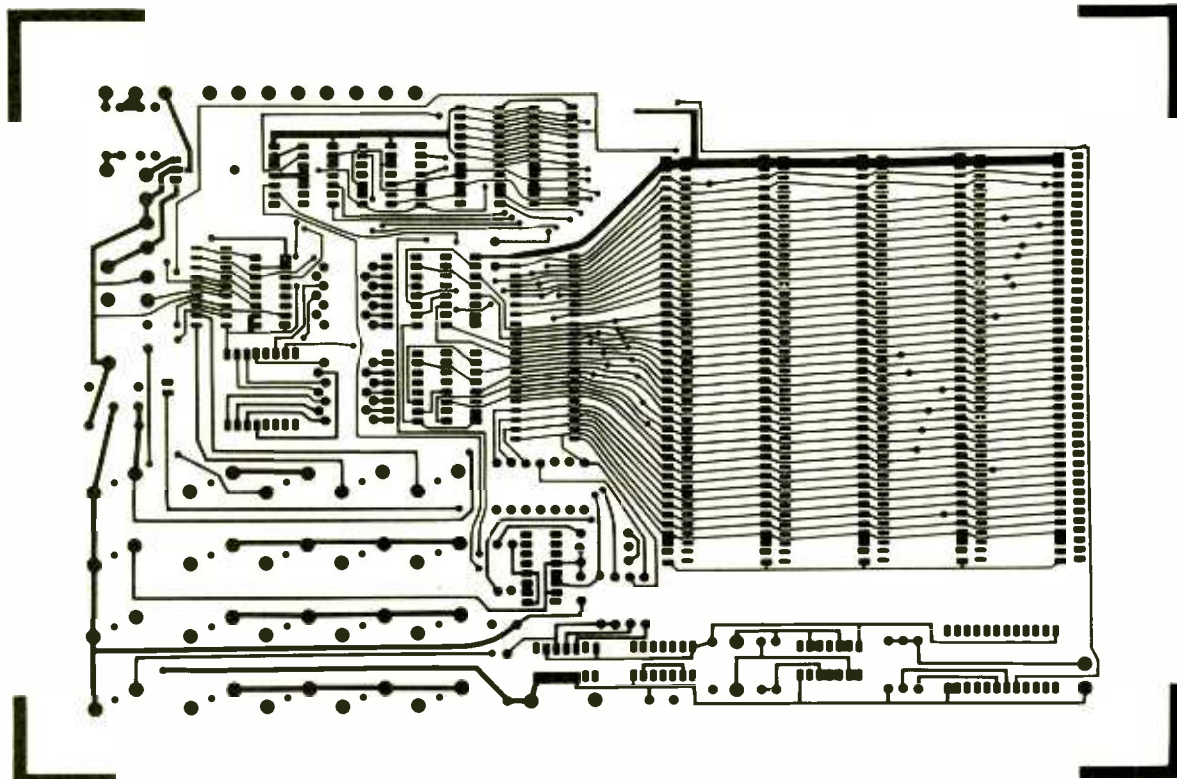

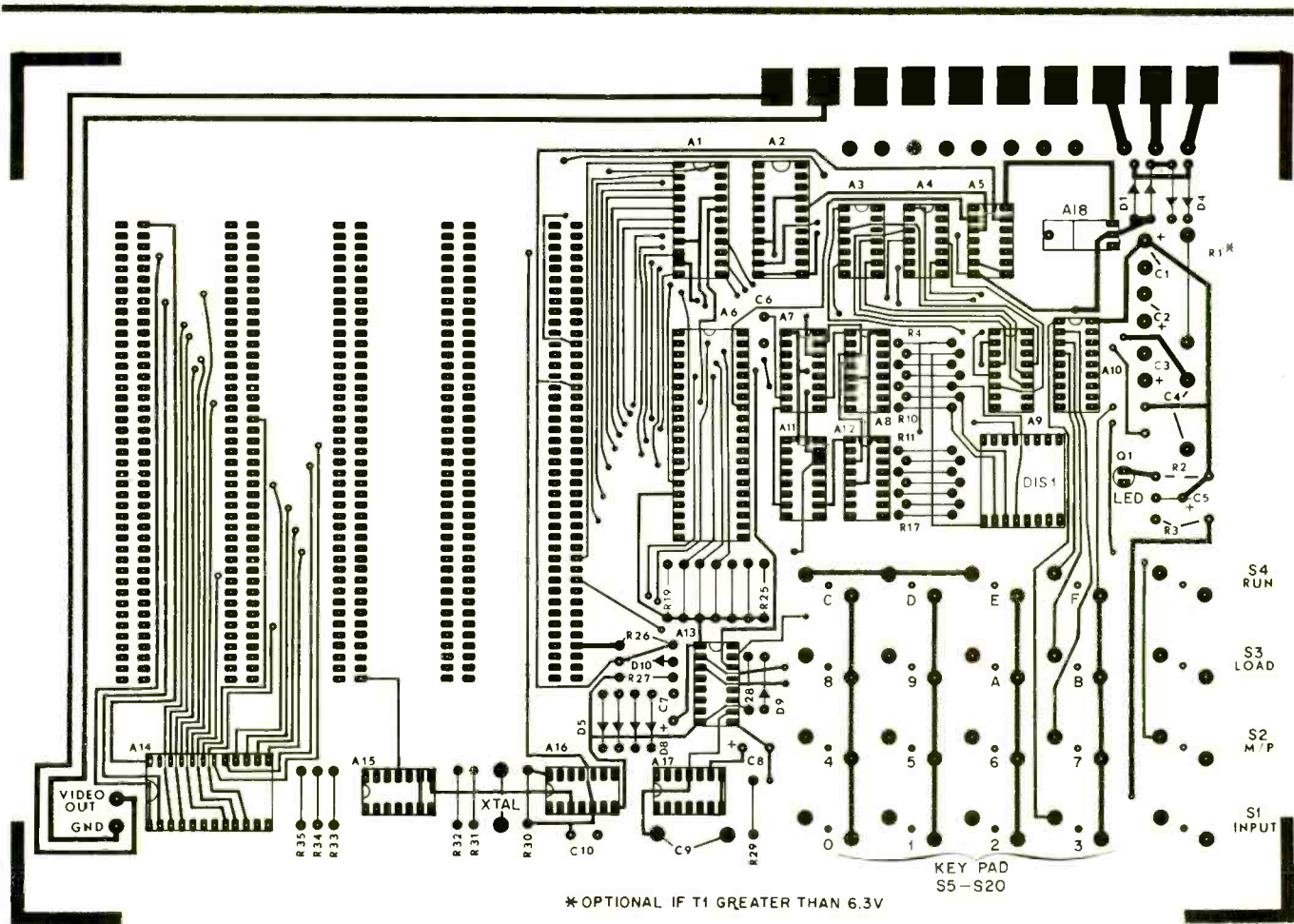
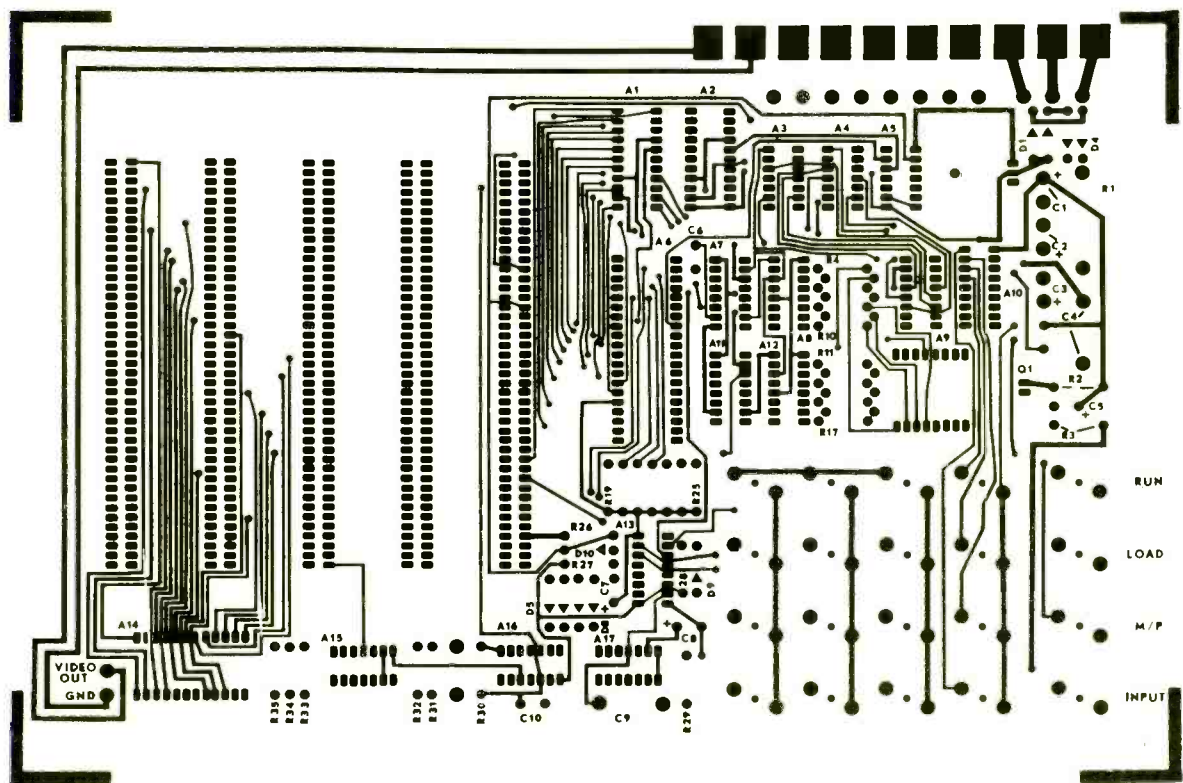

Fig. 8. The Elf-II uses a double-sided, plated-through, single pc board, having the foil pattern shown here (reduced to 1/2 size). The figure also shows component placement.



**PROGRAM 2 VIDEO TEST**

Memory Location	Data
<b>Start</b>	0000 90 B1 B2
	0003 B3 B4
	0005 F8 2D A3
	0008 F8 3F A2
	000B F8 11 A1
	000E D3
<b>Return</b>	000F 72
	0010 70
<b>Interrupt</b>	0011 22 78
	0013 22 52
	0015 C4 C4 C4
	0018 F8 00 B0
	001B F8 00 A0
<b>Refresh</b>	001E 80 E2
	0020 E2 20 A0
	0023 E2 20 A0
	0026 E2 20 A0
	0029 3C 1E
	002B 30 0F
<b>Main</b>	002D E2 69
	002F 3F 2F
	0031 6C A4
	0033 37 33
	0035 3F 35
	0037 6C
	0038 54 14
	003A 30 33

form of modified ac/dc TV set unless it uses a line isolation transformer.

With the CRT monitor connected and power applied, a raster should be seen on the screen. Using the same technique that was used to load the flashing LED program, load Program 2, the video test software. Once loaded, depress the RUN switch, and note that the CRT monitor should synchronize to the Elf-II sync signals and display a stable raster, with a "cloud-like" display near the top of the raster. This cloud-like layer is actually the program you just inserted. The 1's appear as bright boxes, while the 0's are represented as dark boxes. (Refer to POPULAR ELECTRONICS July, 1977 issue for further details on video programming including how to animate the display.

Adjust the CRT monitor brightness and contrast controls for the best picture. If the sync appears to be unstable, or there does not seem to be enough contrast, one or two resistors in the Elf-II might require a different value, to increase or decrease the sync level. For instance, resistor R34's value can be changed. To make changes in the video level R35 can be altered. Neither resistor affects circuit operation, just the level of its associated signal source.

**Programming.** Although learning to program the 1802 is not very difficult, training and practice are required. The reader is urged to purchase the COSMAC User's Manual, which is available from your local RCA Distributor or from the source listed in the Parts List. The reader is also urged to read the four "Build the COSMAC Elf" articles that appeared in POPULAR ELECTRONICS. They include details on programming as well as how to animate a video display:

1. Part 1, August, 1976. This first article covered the construction of the Elf, discussed the 1802, fundamentals of memory addressing, use of registers, and an introduction to programming.

2. Part 2, September, 1976. The second article covered the use of a photocell or switch as a flag input, how to expand the I/O lines, a method of controlling up to 16 outputs, and further programming details.

3. Part 3, March, 1977. This section covered operating systems, how to hook up a keyboard, and how to expand memory. A few reader-supplied programs were illustrated.

4. Part 4, July, 1977. This article covered the installation of a single-chip graphics interface, showed some graphics programming and how to animate. ◊

# IN WIRE-WRAPPING HAS THE LINE...

**HOBBY-WRAP-30 WIRE-WRAPPING, STRIPPING, UNWRAPPING TOOL FOR AWG 30 (.025 SQUARE POST)**



**STRIP**

**WRAP**

**UNWRAP**

## **OK MACHINE & TOOL CORPORATION**

3450 CONNER STREET BRONX, NEW YORK, N.Y. 10475 U.S.A. • PHONE (212) 694-6600

TELEX: 125091 TELEX: 232395

# Digital Electronics/Microcomputers

## PRODUCT DIRECTORY

### COMPUTERS

\*Uses Altair bus. See *Module Boards and Peripherals* sections for directly interfacing equipment.

\*\*Uses SWTP 6800 bus. See *Module Boards and Peripherals* sections for directly interfacing equipment.

#### APPLE COMPUTER

##### APPLE II

6502-MPU computer with built-in keyboard, 6k BASIC and 2k monitor in ROM, 4k-48k RAM, interfaces for cassette (1500 char/sec, color video (text, graphics, or mixed) and video-game paddles or joysticks. Video output, 40 characters × 24 lines, uppercase, normal, inverse, or flashing; full cursor control. Graphics 40 × 48 resolution (40 × 40 with four lines text) in 15 colors; high-resolution graphics (requires 12k memory), 280 × 192 (280 × 160 with four lines text) in black, white, and two colors. Apple BASIC has special color, graphics, and game commands. Assembled, in case. Weight 10 lb. With 4k/8k/16k/48k ..... \$1298/\$1398/\$1698/\$2638  
**Apple II Board.** Same, less case, power supply, and keyboard. With 4k/8k/16k/48k ..... \$598/\$698/\$978/\$1938

#### BYTE

##### BYT-8\*

Altair-bus mainframe, with 8080 MPU, 10-slot motherboard, 10-amp power supply, real-time clock,



front panel with power and reset controls. Kit .. \$349  
 Chassis only, less MPU ..... \$229  
**BYT-8-CP.\*** Control panel with 48 indicators of address, data, status, I/O, and state, control switches (including single-step and hardware breakpoint) ..... \$190

#### CENTRAL DATA

##### 2650 COMPUTER SYSTEM BOARD

2650-MPU computer, including 80-character, 16-line video output, 300-baud Kansas-City-standard cassette interface, 1024-byte PROM supervisor with breakpoint and cassette routines, PROM expandable on-board to 4096 bytes. Includes 64-character uppercase character generator, space for additional 64 user-created characters, 750 bytes user-available RAM. Requires 5 V, 1.7-5.3 A, according to PROM population. Wired ..... \$325  
**S-100 Bus Motherboard.\*** Expansion board for 2650 computer, accepts Altair-bus memory or I/O boards ..... \$110  
**Software.** Editor/assembler and BASIC, on cassette. Each ..... \$20

#### CGRS MICROTECH

##### μPUTER 6000\*

6502-MPU computer consisting of Altair-bus MPU board with power-up restart, front panel, six-slot motherboard, and power supply, all available separately. Cabinet available.  
**Level II System.** MPU with 2k RAM, 4k PROM (2708); front panel with hexadecimal displays; 12-A power

supply. Kit/wired ..... \$345/\$425  
**Level I System.** Same, except 256-byte RAM, no

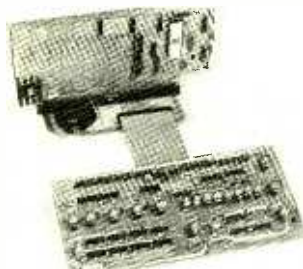

ROM, front panel with binary displays. Kit/wired ..... \$265/\$315  
**Expansion Kit.** Level I to Level II ..... \$100  
**Front Panel**  
 Address, data, reset, memory protect and single-step switches, data and address displays. For μ-puter 6000, but also plug-compatible with Motorola EXORcisor boards. Motherboard available for Altair-bus module boards and peripherals. Requires 5 V, 1 A.  
**Level II.** Hex display. Kit/wired ..... \$120/\$180  
**Level I.** Binary display. Kit/wired ..... \$90/\$100

#### CHILD ODYSSEY

##### MICROE-MACHINE

1802-MPU computer, built on two Vectorboards for flexibility in prototyping or education. Includes 5-V,



1-A power supply, binary-switch input, LED output, and 156-byte memory. Kit ..... \$90  
**Wire-wrapped version** ..... \$100  
**Additional memory, 256-byte** ..... \$5

#### COMMODORE

##### PET COMPUTER 2001

6502-MPU, self-contained computer. Includes built-in keyboard with 64-character ASCII uppercase



plus 64 graphics-related characters; 9-in. video display for graphics, 40-character × 25-line alphanumerics, or both; 4k RAM memory (8k optional), ex-

pandable to 32k; 12k ROM including 8k BASIC interpreter and 4k operating system; built-in audio-cassette recorder (file management system in BASIC); interfaces for additional recorder and IEEE-488 instrument interface bus. Wired.

4k/8k ..... \$595/\$795

#### COMP-SULTANTS

##### MICRO-440

4040-MPU, 4-bit computer, with hardware monitor, continuous display of accumulator and carry, bidirectional address stepping, single-step. With 256 bytes RAM and power supply; less box, mounting hardware and I/O connectors. Kit/wired ..... \$174/\$194  
**Enclosure, mounting hardware, and I/O connectors** ..... \$40  
**Micro-440 with enclosure, hardware, and connectors.** Wired ..... \$239  
**2k RAM Expansion.** Kit/wired ..... \$154/\$184  
**2k PROM Board.** Kit/wired ..... \$76/\$84

#### COMPUCOLOR

##### 8001

8080-MPU terminal computer with 19-in. color video display, keyboard in separate housing. Basic system includes 11k ROM (including BASIC and monitor) plus space for 21k additional; 16k RAM (8k reserved for screen refresh and scratch pad, 8k user-available) plus space for 16k additional; 31 ports (of 512 available) implemented, including two RS-232 serial and two parallel ports; baud rates from 110 to 76.8k. Video display: 80 characters × 48 lines; 64 ASCII characters plus 32 lowercase ASCII with descenders; 160 × 192 graphics with software for vector, bargraphs, and point plot; white, blinking over-score/underscore nondestructive cursor; eight foreground colors independent of eight background colors; editing features including erase page, erase line, cursor positioning, page/roll mode, insert/delete character/line. Programs on continuous-loop 8-track Floppy Tape cartridge, 4800 baud with RS-232 serial interface. With single Floppy Tape drive. Wired ..... \$2750  
 With dual Floppy Tape drive ..... \$2995  
**Additional 8k RAM** ..... \$375  
**Light Pen** (factory-installed) ..... \$550  
**Numeric Keypad** (factory-installed) ..... \$90  
**16 Special-Function Keys** (factory-installed) ..... \$300  
**Single Floppy-Tape drive** (capacity 16k bytes) ... \$250  
**Dual Floppy Tape Drive** ..... \$450  
**CompuColor Mini-Desk Drive** (to 110k bytes) ..... \$750  
**Dual Mini-Disk Drive** ..... \$1250

#### COMPUTER POWER AND LIGHT

##### COMPAL-80\*

8080-MPU computer; includes power supply, motherboard, real-time clock, vectored interrupt, ROM

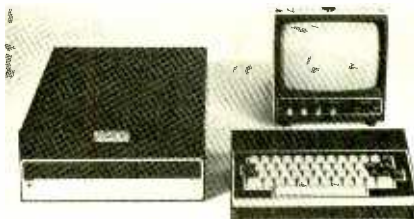

system monitor, 16k RAM, serial port (RS-232 or current loop), motherboard\*, 300/2400 baud cas-

sette interface, 16-line x 64-character video display output (full ASCII plus 48 x 128 graphics modes), keyboard in separate housing, 9-in. CRT monitor and system cabinet, plus BASIC, clock and PLOT functions. Wide range of peripherals and software available. Wired only. With 16k/24k/32k memory ... \$2300/\$2675/\$2875

### CROMEMCO

**Z-1\***  
Z-80 MPU computer with front panel controls and indicators. Uses selected, high-speed Z-80 MPU



chip, 21-slot motherboard, PROM programmer with 8k capacity (2708), 32-A power supply, 8k RAM memory, RS-232 serial interface, 1k monitor. Wired ..... \$2495

**Z-2\***  
Similar, but without front panel. Power-on jump circuitry begins automatic program execution when power is turned on. Rack-mount design (cabinet optional) with 60-A power supply for cards and other peripherals; special 21-slot Blitz-Bus motherboard design to reduce ground-current noise. Kit/wired ..... \$595/\$995

### CYBERSYSTEMS

**MICROCYBER 1000**  
6502-MPU system with built-in hexadecimal keyboard and display, 2k ROM operating system, 1k memory, power supply, interfaces for audio cas-

## NOTICE TO READERS

We consider it a valuable service to our readers to continue, as we have in previous editions of this guide, to print the price set by the manufacturer or distributor for each item described as available at presstime. However, almost all manufacturers and distributors provide that prices are subject to change without notice.

We would like to call our readers attention to the fact that during recent years the Federal Trade Commission of the U.S. Government has conducted investigations of the practices of certain industries, in fixing and advertising list prices. It is the position of the Federal Trade Commission that it is deceptive to the public, and against the law, for list prices of any product to be specified or advertised in a trade area, if the majority of sales of that product in that trade area are made at less than the list prices.

It is obvious that our publication cannot quote the sales price applicable to each trading area in the United States. Accordingly, prices are listed as furnished to us by the manufacturer or distributor. It may be possible to purchase some items in your trading area at a price that differs from the price that is reported in this edition.

The Publisher

sette, TTY, RS-232, and two parallel I/O ports. Memory or I/O expansion capability within cabinet; expansion chassis available. Wired ..... \$525  
**4k RAM Static Memory** ..... \$189  
**8k RAM Static Memory** ..... \$299  
**Expansion chassis** with 10 slots for memory or I/O expansion ..... \$350  
**Basic chassis**, for use with KIM-1 ..... \$320

### DATAC ENGINEERING

**DATAC 1000**  
6502-MPU computer card with touch-pad data and control entry (no moving parts), binary LED display. TTY I/O monitor in ROM, 1k RAM, sockets for 2k PROM, cassette and serial interfaces, two parallel I/O ports, power-on reset or restart. Buffered bus on 72-pin edge connector for external expansion. With power supply, 1000 T ..... \$185  
 1000 E. Same, with TIM monitor ..... \$345

### THE DIGITAL GROUP

**Z-80**  
Versatile, multi-option computer based on an exclusive bus structure permitting interchangeable CPU cards (Z-80, 8080A, 6800, and 6502 MPU cards are currently available). System prices below for Z-80; deduct \$50 for 8080 or 6800, \$100 for 6502. Many configurations available; items below are just sampling.  
**Z80-3BD.** Z-80 system with 2k memory, plus video, cassette, and four-port parallel I/O. Kit/wired ..... \$475/\$695  
**Z80-4BD.** Same, with 10k memory ..... \$675/\$945  
**Z80-SYS1.** Same, with power supply (12 A), larger motherboard (nine slots), and cabinet. Kit/wired ..... \$895/\$1295  
**Z80-SYS3.** Same, plus keyboard, 9-in video monitor, and digital-cassette system, in cabinets. Kit/wired .. \$2045/\$2545



Other options include 8k and 300 nsec low-power 8k memory boards, 18-A power supply, 4k EPROM board, additional I/O, digital-cassette storage drives and cabinet, keyboard, and printer (see Peripherals section), prototyping and extender cards; 64 x 64 color graphics board.

### E&L

**MMD-1 MINI-MICRO COMPUTER**  
8080A MPU educational microcomputer system with built-in breadboard sockets; comes with Bug-

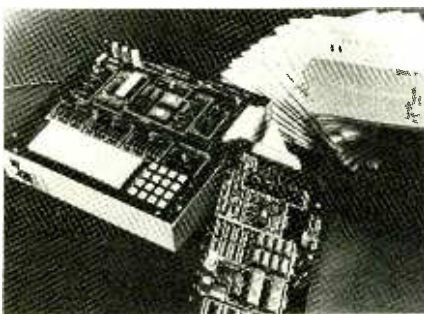

book self-teaching training course. Features octal keyboard and binary display, power supply, 256-byte PROM operating system (expandable on-board to 512 bytes); 512-byte RAM (expansion available). Kit/assembled ..... \$423/\$600  
**MMD-1/MI.** Memory/interface board with TTY and 300-baud cassette interfaces, 1k RAM expandable on-board to 2k + 1k ROM. Powered by MMD-1. Kit/wired ..... \$195/\$250  
 Also available are outboard octal and hex displays, ports, single-step adapter, programmable timer/counter, PROM (1702) programmer, others.

### MICRO DESIGNER

Developmental modular microcomputer system; openface configuration allows direct, solderless access to all bus lines, control signals, and power.  
**CPIC-80B.** CPU/interface controller, with 8080A, clock, buffers, and control logic ..... \$175  
**MCP-80/B.** Control panel with switches and indicator lights ..... \$184  
**MB-80/B.** Memory with 256-byte PROM, plus RAM. With 1k/2k/3k ..... \$180/\$220/\$260  
**ASB-80/B.** Serial interface (20 mA or RS-232), with paper-tape reader control for ASR-33 ..... \$207  
**IF-102.** Motherboard with five slots ..... \$115  
**IF-101.** Same, with breadboard sockets ..... \$200  
**CDP-5 Power Supply.** 5.75 A, with crowbar protection on +5 V line ..... \$285

### ECD

**MICROMIND I**  
6512A-MPU computer with 8k memory (expandable to 16k on board, to 64k with expansions, and to 64M

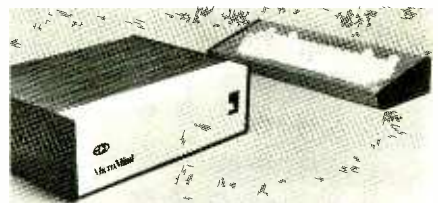

with optional memory mapping. Includes power supply, cabinet, 80-key keyboard with user-definable characters, graphics and alphanumeric video output, audio cassette interface (for up to four recorders), ROM monitor. Eight serial and one parallel I/O ports. Wired ..... \$988

### MICROMIND II

Same, with 16k main memory, memory-mapping option for up to 64M memory, analog I/O, vectored interrupt, cycle-suppression and message interrupts (all also available as options for MicroMind I).  
 Wired ..... \$1387  
**32k Memory-Expansion Board** ..... \$1000

### ELECTRONIC CONTROL TECHNOLOGY

**ECT-100-8080\***  
8080-MPU computer in 20-slot card cage that fits 19-in racks, with motherboard and power supply; 8080 MPU card with power-on jump to selectable starting address (for systems with ROM monitors); 20 card connectors and guides. Kit/wired ..... \$320/\$500  
**ECT-100-Z80.** Same, with Z-80 MPU ..... \$420/\$500

### ELECTRONIC PRODUCT ASSOCIATES

**MICRO-68b**  
6800-MPU computer with 16-key hex keypad, six-digit hex LED display; 8k RAM memory expandable

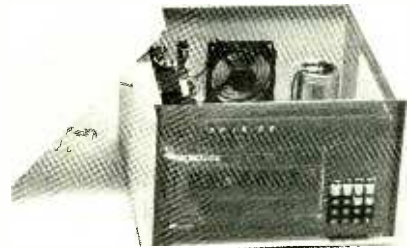

to 64k; 25-A power supply; ROM monitor, editor, and I/O; TTY/RS-232 and Kansas-City-standard cassette interfaces. In fan-cooled cabinet with 13-slot motherboard (also accepts Motorola EXORcisor cards). Available with extra I/O and bus connections at front panel. M68b. Wired ..... \$1878

### MICRO-68

6800-MPU, with hex keypad and display, 128 bytes of RAM, 512-byte ROM monitor/editor, power sup-



ply, one I/O port. In wood/plexiglass cabinet with room for 640 words additional ROM; other options below.

M68C. Wired	\$495
X68C. Expanded version with 8k RAM, 3.5-A power supply, additional ROM for TTY, TTY/RS-232 and cassette interface, expansion cabinet	\$1186
RAM8K. 8k static memory	\$390
RAM4K. 4k static memory	\$290
M6810. Additional 128-byte RAM for Micro-68	\$6
PEB1. 16k PROM board for 7641/3624 PROMs	\$240
PROM512. 512-byte PROM for above (programming available)	\$24
PEB2. 512-byte PROM board for Micro-68	\$18
PROM256. 256-byte PROM for above (programming available)	\$10
MB6830L7. MIK-bug ROM for TTY	\$29
TTY4. TTY PROM	\$24
GP1. General purpose prototyping board	\$30
TCC3. I/O for Byte-standard cassette, RS-232 terminal and TTY (requires TTY4 or MIK-bug ROM)	\$129
TVA-1. Video interface and TV adapter for 29-line, 30-character display. Includes keyboard input and RS-232 interface. For X68c	\$245
IMP-68X. Interface for IMP1 printer (see Peripherals)	\$22
ADC-1. 12-bit analog-to-digital converter	\$382

### ELECTRONIC TOOL

ETC-1000  
6502-MPU computer accepts wide variety of processors (Z-80, 8080A, M6800, and F8) for alternate or multiprocessor use. Basic system includes 6502 control processor, 256-byte ROM (expandable on processor board to 4k), 1k RAM, eight-digit LED display, hex and control function keys, eight I/O device-control lines, two serial I/O lines, and interrupt system with eight levels, plus choice of two power supplies. Space in cabinet for up to 16 expansion options, such as additional MPUs, ROM,

RAM, peripheral controllers and external interface modules for real-time control. Memory map option allows expansion to 4M. Other options include 220-V and low-voltage power supplies, bus expansions, and peripherals. Wired	\$775
1000S. Stretch chassis option for above (32-slot)	\$100
1003. 28-A power option	\$75
1011. Power-on restart, user-addressable	\$55
1013-4. Battery backup	\$270
1023. Altair-compatible bus extension for use of Altair-bus-compatible modules with ETC system	\$90
1046. Cassette I/O	\$65
1100. 4k RAM	\$235
1120. 8k RAM	\$385
1406. 16k PROM module	\$215
1407. 8080A MPU with 1k private RAM, ROM	\$325
1408. M6800 MPU with control ROM	\$255
1411. F8 MPU with ROM and 1k RAM	\$325
1413. 6502 MPU with ROM and 1k RAM	\$325
1414. Z-80 MPU	\$299
1415. Z-80 MPU with ROM, 1k RAM, room for additional 1k ROM	\$425
1501. Video interface. 16 x 64 characters	\$385
1503. Alphanumeric keyboard	\$125

### GNAT

GNAT-PAC



8080-MPU system, available with built-in mass stor-

age. Basic system includes MPU with eight vectored interrupts, 16k RAM module (expandable to 64k), 1k PROM monitor (expandable to 16k), slots for four additional module boards, cabinet and power supply.

GP. Gnat-Pac base unit. Wired	\$1750
SYS 7. Same, with 3M data-cassette drive, 1k PROM with drivers, tape operating system with assembler, editor on 3M data cassette	\$2795
SYS 8. Same, with Minifloppy disk drive instead of cassette drive. DOS with file manager, etc., on diskette; disk-based BASIC compiler available	\$2895
8005. Hardware multiply/divide module	\$225
8031. I/O module, one serial, two parallel	\$225
8035. Four-port serial I/O	\$300
CA-1. Cable (one required for each serial port)	\$15
8090.92. Front panel display and control	\$350

### HAL

#### EIGHT THOUSAND

Compact, 8080-MPU computer with 1k ROM monitor, up to 16k RAM (externally expandable to 64k), one serial port (RS-232 or 20 mA, ASCII or Baudot), video output (16 lines x 64 characters), power supply, and cabinet. With 2k/9k/16k

	\$1195/\$1425/\$1650
MCEM-8080. Single-board version, with 1k ROM monitor, ports, RAM only	\$375
MCEM-DACI. Dual audio cassette interface. Kansas-City standard, 300 or 600 baud (1200 baud selectable), for two audio cassette recorders	\$150
MCEM-7K RAM. 7k static memory	\$300
MCEM-4K RAM. 4k static memory	\$245
MCEM-PROM-PROG. PROM programmer for use with 7K RAM Board	\$35
HAL Tiny BASIC in EPROM	\$250

### HEATH

#### H8

Computer with 8080A MPU, 1k ROM monitor for load-dump and front-panel operations; front panel with octal keypad and digital display. With 10-slot

**IN WIRE-WRAPPING  HAS THE LINE.....**

**MODEL WD-30**



PATENT PENDING

## WIRE DISPENSER

- 50 FT. ROLL OF 30 AWG. KYNAR® WIRE-WRAPPING WIRE
- CUTS THE WIRE TO LENGTH
- STRIPS 1 INCH OF INSULATION

**AVAILABLE IN FOUR COLORS**

WD-30-B	BLUE WIRE
WD-30-Y	YELLOW WIRE
WD-30-W	WHITE WIRE
WD-30-R	RED WIRE

**\$345  
EACH**

MINIMUM BILLING \$25.00  
ADD SHIPPING CHARGE \$1.00  
NEW YORK STATE RESIDENTS  
ADD APPLICABLE TAX

®KYNAR PENNWALT

**OK MACHINE & TOOL CORPORATION**

3455 Conner St., Bronx, N.Y. 10475 (212) 994-6600 / Telex 125091

cabinet using Heath 50-pin bus; power supply capable of handling up to 32k of memory and two I/O interfaces; programmable speaker and LED status lights. Kit, with wired and tested CPU; BASIC, assembler, editor and debug programs on audio cassette ..... \$375  
**8k RAM board with 4k** ..... \$140  
**4k RAM chip expansion set** ..... \$95  
**Serial I/O board with 1200 baud audio cassette interface** ..... \$110  
**3-port parallel interface** ..... \$150

**H11**  
 Computer with LSI-11 16-bit MPU accepting PDP-11 software; 4k x 16 dynamic RAM expandable to 20k; backplane; power supply with switching regulators and full circuit protection; I/O interface; DEC software package with editor; PAL-11 assem-

bler, linker, on-line debugger, I/O executive, BASIC and FOCAL kit, with assembled MPU ..... \$1295  
**4k x 16 static RAM** ..... \$175  
**Serial interface** ..... \$95  
**Parallel interface** ..... \$95

### IASIS

**ia7301**  
 8080 MPU, single-board computer with built-in hex keyboard and display, 1k PROM monitor (space for

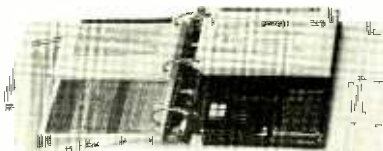

2k), 1k RAM, two I/O ports plus audio cassette interface. LEDs signal end of tape read or write operations. Requires +5 V, +12 V only (-5 V derived internally); power supply optional. Computer is built into a 500-page, looseleaf programming manual; computer board has plexiglass cover with cutout for keys. Wired ..... \$495

### IMSAI

**8080 SYSTEM**  
 MPU board includes 8080A, clock, tri-state bus drivers, and control-signal timing. Front-panel control board plugs into one slot, features large paddle-



handle address/data switches, and LED masks. Has eight LEDs, program-controlled. Power supply delivers up to 20A at 8V, and 3A for ±16V. Heavy-gauge aluminum cabinet has room for up to 22 cards; six-slot motherboard standard, four-slot expansions and 22-slot motherboard optional. Memory expandable up to 65k bytes, or up to 1 M with Intelligent Memory Manager option. Rack-mounted system is \$20.00 more. Many mechanical options (fan, connectors, cables) available. Many hardware options, including memory (RAM, PROM, EPROM), multiprocessors and shared memory, I/O interfaces, disk drives, video display and keyboard terminals, printers, software including bootstrap loaders, BASIC, floppy-disk operating system.

**I-8080**. Basic computer system. Kit/wired ..... \$699/\$931  
**I-8080-OEM**. Same, without front panel. Kit/wired ..... \$629/\$731

**8048 SINGLE-BOARD CONTROL COMPUTER**  
 Single-board computer for control and similar applications. Includes 8048/8748 MPU, 24-pad hexadecimal keypad, nine-digit LED hex display, 12 I/O lines with handshaking, 14 other I/O lines, five heavy-duty relays, RS-232 and cassette interface. Monitor in ROM or EPROM (optional). Requires 5-6 V. Includes 1k byte RAM memory, sockets for 1k bytes additional RAM and 2k of ROM/EROM, expandable to 64k RAM off board.  
**ROM Version**. Kit/wired ..... \$249/\$299  
**RAM Version**. Kit/wired ..... \$399/\$499  
**5-V Power Supply** ..... \$99

### INFINITE

**UC 1800**  
 For training or evaluation, uses RCA COSMAC 1802 MPU; 16-key hex keyboard; digital hex display of address, memory contents, I/O port; front-panel control of interrupt, DMA; I/O flag; 256-byte RAM expandable to 65k bytes of RAM or ROM internally; crystal-controlled clock; parallel and serial I/O data-line capability; special circuit saves memory content when unit is turned off ..... \$495

**Option 001**. Automatically recharged internal battery; allows program memory to operate up to four hours after power failure ..... \$25  
**UC 1800K**. UC 1800, less cabinet and power cord ..... \$389  
**UC1800HK**. Parts kit including PC boards, keyboard, crystal, ROM, MPU, readouts, cable, and manual (requires additional, commonly available parts) ..... \$130

### INTEL

**SDK-80**  
 Single-board, 8080A-MPU computer with serial and parallel I/O, power-on reset, 256-byte RAM memory, 1k ROM monitor, connectors for off-board expansion, and pre-drilled areas for system expansion on-board. Kit only ..... \$250

### INTERSIL

**INTERCEPT, JR.**  
 Tutorial microcomputer system using Intersil's IM6100 CMOS 12-bit microprocessor and related



CMOS devices. Uses DEC PDP-8/E instruction set. Multi-function octal keyboard and octal display. Includes 1k x 12 ROM monitor plus socket for additional ROM, 256 x 12-bit CMOS RAM. On-board battery for battery operation or non-volatile memory; connections for external 5-V or 10-V supply.  
**6950** ..... \$281  
**6951**. 1k x 12 CMOS RAM module, with battery backup ..... \$145  
**6952**. 2k x 12 ROM/PROM module ..... \$75  
**6953**. Serial I/O (RS-232 or 20 mA), with ROM bootstrap for DEC BIN-format media ..... \$82  
**6957**. Audio-visual module with switch register input, binary and octal readouts, volume-controlled speaker ..... \$125

### LOGIC DESIGN

**LD14 LABORATORY DESIGN COMPUTER**  
 Digital logic/computer-architecture training computer. Pushbutton controls and binary LED displays for all functions and signals. Breadboarding system included. Wide-range clock (200 nsec-5 sec) allows operation speed to be reduced for visual tracing of program action. Includes power supply ..... \$1595

### MARTIN RESEARCH

**MIKE 8 MODULAR MICRO**  
 Z-80 MPU, modular computer. Includes calculator-type keypad and display, PROM/RAM board and



monitor, CPU, other options.  
**872**. Includes 512 bytes RAM (expandable on board to 1k), space for 1k PROM plus 1k PROM monitor ..... \$495  
**880**. Same, but with 1k RAM (expandable to 4k), 2708 programmer with space for two PROMs, 1k monitor ..... \$675  
**881**. Same, with extra 1k PROM, 4k RAM ..... \$795

### ELECTRONIC EXPERIMENTER'S HANDBOOK



Thousands of copies of our innovative book on microprocessors are in use by hobbyists, engineers, and designers worldwide! Now, **MICROCOMPUTER DESIGN** is available for only \$14.95, at your nearby computer store, or direct from the publisher. Over 400 pages, packed with hard-to-find details like these:

- 8080 circuits, theory of operation
- Vectored interrupts, for all 8-bit central processing units
- Efficient bus structure design
- Interfacing to timers, A/D converters, keyboards, digits, and other I/O devices
- Plus much more!

Please send \_\_\_\_\_ copies of MICROCOMPUTER DESIGN at \$14.95 (\$20 outside USA).  
 Enclosed is \$\_\_\_\_\_. (Residents of Illinois, add 5% sales tax.)  
**CHARGE.**  
 BankAmericard       Master Charge  
 Account # \_\_\_\_\_ Exp. Date \_\_\_\_\_  
 Master Charge Interbank # \_\_\_\_\_  
 (4 numbers over your name)  
 Signature \_\_\_\_\_  
 Print Name \_\_\_\_\_  
 Address \_\_\_\_\_  
 City \_\_\_\_\_ State \_\_\_\_\_ Zip \_\_\_\_\_

**martin research**  
 3336 Commercial Avenue  
 Northbrook, IL. 60062  
 (312) 498-5060

### MIKE 3 MODULAR MICRO

8080-MPU version of MIKE 8.

- 813. Equipped as 872, but with 256-byte monitor ..... \$395
- 814. As above, with added Debug PROM (including 32-channel scope display output) and display. \$495
- 822. As 882 but with 8080 power supply (+5 V @ 3 A, ±12 V @ 0.8 A each), plus debugging as 814 above ..... \$995
- AT423-1. PROM/RAM board. Space for 2k PROM (1702) and 1k RAM ..... \$78
- AT424-4. Serial interface. Two serial I/O ports (ES-232/20 mA) ..... \$179
- AT423. PROM/RAM board. Space for 8k PROM (2708) and 1k RAM ..... \$119
- AT424-4. Serial interface. Two serial I/O ports (RS-232 and 20 mA) ..... \$179
- AT 405-4. 4k RAM board ..... \$179
- K7909. I/O Kit. Two pairs of I/O ports, one memory-mapped, one standard ..... \$35

### MICROCOMPUTER ASSOCIATES

#### JOLT

6502 MPU, low-cost system with DEMON debug-monitor in ROM, interfaces automatically to any terminal speed from 10 to 30 char/sec. Includes serial interface with 20 mA or RS-232, 512-byte RAM memory, 16 programmable I/O lines, power-on reset. Requires +12 V, +5 V, -10 V. Expandable with modules below. Kit/wired ..... \$259/\$245

#### SUPER JOLT

Similar to JOLT, but with 1k RAM, 32 programmable I/O lines, interval timer, four interrupts, three serial interfaces (20 mA, RS-232, and TTL), 5k ROM (monitor, resident assembler, and Tiny BASIC interpreter). Wired, with/without assembler and BASIC ROMs ..... \$375/\$575

#### OEM SYSTEM CARDS

- JOLT-compatible MPU cards, with choice of 8080A, 6502, 6800, or 2650 processor. Includes clock, 1k RAM, sockets for 2k PROM or 4k ROM, 24 bidirectional I/O lines, fully buffered address/data lines, interrupts. Supported by JOLT modules below, serial I/O (8080A/9080A). Assembled ..... \$375
- JOLT 2k PROM. Wired ..... \$149
- JOLT 4k RAM. Kit/wired ..... \$199/\$285
- JOLT I/O. Peripheral interface (parallel) adapter; two PIA chips, 32 I/O lines, four interrupt lines; fully programmable. Kit/wired ..... \$96/\$140
- JOLT 6502 Resident Assembler. In ROM, requires 2k PROM card, at least 4k RAM. Delivered on 7 PROMs (1702A) ..... \$395
- JOLT Universal Card. Blank, drilled for 14-, 16-, 24-, or 40-pin sockets ..... \$25
- JOLT Power Supply. +5, +12, -10 V. Supports JOLT MPU, 4k RAM and I/O or MPU and eight I/O cards. Kit/wired ..... \$99/\$145
- JOLT - 5 V Booster Option. Fits onto JOLT power supply card; supports MPU, 16k bytes RAM, or MPU, 8k RAM, eight I/O, or MPU, 4k RAM, and 16 I/O ..... \$25
- JOLT Tiny BASIC. Resides in 2304 bytes of memory. PROM version requires two 2k PROM cards (nine PROMs). Paper tape/PROM ..... \$25/\$270

### MINITERM ASSOCIATES

#### SYSTEM 80/2-1\*

Z-80-based system with eight-slot card-cage and motherboard, 16k dynamic RAM (no wait @ 4 MHz), 90-key keyboard, 10-A power supply, minifloppy interface for up to three drives, one minifloppy drive, software and firmware. Wired ..... \$2699

### MITS

#### ALTAIR 8800b\*

Second-generation Altair 8800. New version compatible with Altair 8800 hardware and software. Features include redesigned front panel, new MPU board, power supply, and one-slot motherboard, expandable to 18 slots. With crystal-controlled clock pulse widths/phasing/frequency. New front panel with multi-color graphics, longer and flat toggle switches. Five new functions in front-panel PROM: Display Accumulator (displays contents of accumulator), Load Accumulator (loads contents of eight data switches into accumulator), Output Accumulator (outputs contents of accumulator to I/O

device addressed by upper eight address switches), Input Accumulator (inputs to the accumulator from the I/O device), and Slow (executes program at about 5 Hz for debugging). Front-panel/MPU interface via two 34-conductor ribbon cables connected to new front-panel interface board. Heavy-duty power supply has +8 V at 18 A +18 V/2 A, -18 V/2 A. Kit/assembled ..... \$750/\$995

#### ALTAIR 680b

Second-generation Altair 680. New version features a 256-byte PROM monitor so that paper tape can be loaded immediately and an Asynchronous Com-

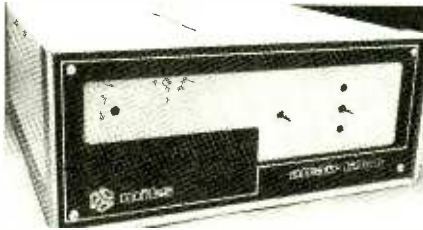

munication Interface Adapter (ACIA) that allows the machine to transmit and receive a character at a time rather than one bit. The MPU is a Motorola M6800, an 8-bit parallel processor with 16-bit address bus, can address 65k bytes of memory, has 72 basic instructions. Measures 11-in. wide, 11-in. deep, 5-in. high. Comes with power supply, front-panel control board, MPU board with 1k RAM, provisions for 768 bytes of additional PROM or ROM, and built-in I/O that can be configured for RS-232 or TTY. A five-level baudot interface option is available, as is a turnkey model without the front-panel switches or lights. Three additional circuit boards can be plugged inside the case. Kit/assembled ..... \$395/\$495

- Altair 680bT. Turnkey model, with no front-panel controls except halt, run, and reset. Kit/wired ..... \$350/\$450
- 680b-BSM. 16k static memory card for 680b; up to three may be used (internal power supply will support two without additions). Kit/wired ..... \$685/\$865
- 680b-U10. Universal I/O for 680b, with one parallel I/O, serial (RS-232/20 mA) ports. Kit/wired ..... \$110/\$160
- 680b-U10-2P. Same, less serial ..... \$60/\$75
- 680b-U10-S. Same, serial port only ..... \$65/\$100
- KCACR. Audio cassette interface, Kansas-City standard. Wired ..... \$250
- 680 PCI. Process control interface, with eight relay outputs for external device control, eight optically isolated inputs for sensory and control information. Kit/wired ..... \$165/\$275

### MORROW'S MICRO-STUFF

#### 8080 MICROPROCESSOR BOARD\*

Combination 8080 MPU/front-panel board, with octal keypad and display, two on-board I/O ports (for

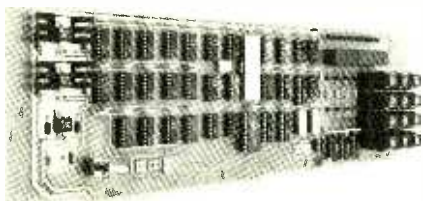

keyboard), 256-byte RAM and 256-byte ROM. Facilities to start, stop, or step any program; processor remains active after HALT command. Kit ..... \$250

### MOS TECHNOLOGY

#### KIM-1 MICROCOMPUTER

6502 MPU, single-board computer with 1.1 k RAM, 2k ROM monitor, 20-mA serial interface, 23-key control and hex data-entry keypad (terminals provided for additional, remote keypad), six-digit LED

### DRILL

in confined areas with new, compact ISO-TIP Electronic Technician Drill.



AC or 12V-powered, it's only 5" long plus bit. Holds #56 and #71 bits (included) or other drills, wheels and burrs to 1/8" shank diameter. Kit includes 4 collets. No. 6275 Drill with 110V transformer; No. 6280 Drill with 12V lighter plug.

### WAHL CLIPPER CORPORATION

ORIGINATORS OF PRACTICAL CORDLESS SOLDERING  
2902 Locust Street  
Sterling, Illinois 61081  
(815) 625-6525

CIRCLE NO 25 DN FREE INFORMATION CARD



Includes Functional Tilt Stand!

**NEW EICO 270**  
**3 1/2 DIGIT DMM KIT**  
**ONLY \$79.95**

### Introductory Offer—FREE AC ADAPTOR

The first and only lab accuracy portable DMM Kit featuring MOS/LSI IC economy and reliability. Measures DC/AC Volts, Kilohms, DC/AC milliamps in 21 ranges. Polarity indicators and overload protection are provided, and 0.5 inch LED displays give easiest-to-read digital readout to 1999. The 270 features a basic 0.5% DC accuracy, 10 Megohm input impedance, low voltage drop in all current ranges and automatically-flashing overrange indicator. **Assembled \$109.95**

### FREE '78 EICO CATALOG

Check reader service card or send 75¢ for first class mail. See your local EICO Dealer or call (212) 272-1134, 9:00 a.m.-5:00 p.m. EST. Major credit cards accepted

EICO—283 Malta St.,  
Brooklyn, N.Y. 11207



CIRCLE NO 8 ON FREE INFORMATION CARD 105

hex display of address and data, audio cassette interface, 15 I/O lines, interval timer under software control. Can be used as stand-alone microcomputer (requires 5 V @ 1.2 A, 12 V @ 100 mA), or expanded with modules below. Assembled ..... \$245  
**KIM-2.** 4k static memory ..... \$179  
**KIM-3.** 8k static memory ..... \$289  
**KIM-4.** Motherboard. Interfaces KIM-1 with up to six system expansion modules, with all required buffering (motherboard not required to interface KIM-1 with a single expansion board). Includes +5 V, +12 V regulators (external power supply required) . \$119

## MOTOROLA

### EDUCATOR II

6800-MPU computer kit contains 128-byte RAM (expandable on-board to 256 bytes), ROM monitor including cassette and cassette-search routines plus routines to test the finished kit. Aluminum case has control and data switches and tape I/O jacks. Edge connectors on PC board for system expansion (keyboard, video display, card rack, memory modules, and cassette programs planned). Kit ..... \$170  
**Additional 128-byte RAM** ..... \$19  
**Educator II Power Supply Kit.** 5 V @ 1 A ..... \$30

### M6800 EVALUATION KIT II

6800-based system with one parallel I/O port, one audio cassette interface, 24-key hex keypad with seven-segment hex displays, 256-byte RAM (expandable to 65k), 1k ROM containing J-Bug hex monitor. Will also accept Motorola Minitbug II or III monitors in place of J-Bug, for use with TTY or RS-232 terminals; up to 3k additional ROM or PROM can be added. Wire-wrapping space provided; buffering may be added for compatibility with EXORciser modules. Requires 5-V, 2-A power supply. MEK6800D2 ..... \$235

### MICROMODULE SYSTEM

6800-MPU modular system, fully compatible with EXORciser system. Choice of three configurations; card cage or rack-mount chassis; various support boards and peripherals.

**M68MMCC05.** Five-card cage ..... \$168  
**M68MMCC10.** 10-card cage ..... \$198  
**M68MMLC1.** 10-card chassis with power supply and fan ..... \$635  
**M68MM01.** MM1 Monoboard Microcomputer 1, with 6800 MPU, sockets for 4k ROM, 1k RAM, six parallel I/O ports ..... \$485  
**M68MM01A.** Monoboard Microcomputer 1A, as above but with four parallel I/O ports, one RS-232 serial port ..... \$495  
**M68MM02.** MPU module. MPU, clock, power-on reset, timing, and control and refresh signals ... \$350

### EXORCISER

6800-MPU system designed for emulation of any M6800 microcomputer configuration. MPU, Debug and Baud-Rate modules supplied; can accommodate up to 12 other modules. With cabinet and power supply. .... \$2600

## M&R

### GEMINI-68

Single-board computer with 6800 MPU bus expandable via double-sided 22-pin connectors. Includes MIKBUG monitor ROM, RS-232 and 20-mA serial I/O, 128 or 384 bytes RAM, Baud rates selectable (110 or 300). Computer requires +5 V, 1.5 A; additional +12 V, 150 mA total, for RS-232. Wired and tested.

**CPU board with 128 bytes RAM** ..... \$260  
**CPU board with 384 bytes RAM** ..... \$280  
**8k RAM Board (pin-for-pin compatible)** ..... \$270  
**8k EPROM Board** ..... \$90

## NATIONAL SEMICONDUCTOR

### SC/MP

Uses SC/MP MPU: 46 instructions, single-byte and double-byte operation, software-controlled interrupts, built-in serial I/O ports, bidirectional eight-bit tri-state parallel data port, latched 12-bit tri-state address port. Includes 512-byte (8-byte) ROM with Kit-board monitor and debug program; 256-byte RAM; eight-bit data buffer; timing crystal; 25-mA current-loop interface; 72-pin edge connector. Kit .. \$99

SC/MP II. Same, but requires only 5V. Kit ..... \$99



### SC/MP Keyboard Kit

Hex keyboard and display for SC/MP. 16 keys for hex command, data and address values; four direct-command keys. Kit ..... \$95

### SC/MP LCDS

Prototyping system for SC/MP. Includes power supply, SC/MP MPU card, interfacing for other SC/MP cards, 20-mA TTY interface, hex keyboard and display. (2k RAM and 4k ROM cards also available). ..... \$499

## NBL

### SCIMP

SC/MP-based computer kit consisting of PC boards, front panel with provision for controls and hex entry pad (probe-and-contact type) and binary LED display, SC/MP MPU, and socket. RAM and other components must be supplied by user. .... \$63

## NETRONICS

### ELF II

1802 MPU, single-board, animated graphics computer, on five-slot motherboard. With hex keypad,

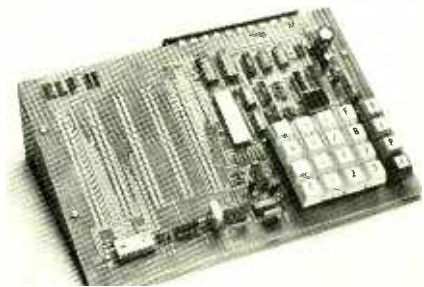

video 64 x 32 graphics display output, 256-byte RAM. 60-terminal ELF bus for expansion of memory (to 64k) and I/O. Requires 6.3-V a.c. Kit ..... \$100

## OHIO SCIENTIFIC

### CHALLENGER

Uses OSI bus to accommodate a variety of modules. MPU module normally uses 6502, but can be



configured for 6800, 6501, or 6512; additional MPUs may be used, under main MPU's control, with 460Z board. Typical system (65V-4K) includes 6502 MPU, video output for 32 x 32 alphabetic, 4k RAM, PROM monitor, one parallel port; case and power supply. 65V-4K. Wired ..... \$675  
**"Dream Machine."** 65V-4K with 16k RAM, single-drive floppy disk, disk bootstrap PROM, keyboard terminal, Sanyo CRT monitor for 16 lines of 64 charac-

ters; BASIC, DOS, and assembler/editor on diskette ..... \$2599  
 With serial port for external terminal, less keyboard, CRT monitor and video interface ..... \$2099  
**Graphics Option.** 128 x 128 ..... \$125  
**Serial Interface Option.** ..... \$100  
**4k Memory.** Board/kit/wired ..... \$29/\$129/\$149  
**Challenger Cassette Interface.** Kansas-City standard; expandable to include parallel I/O, eight-channel A/D, two-channel D/A when fully populated.  
**430B.** Board/wired for cassette/fully populated ..... \$29/\$89/\$349  
**Video Graphics.** Video output for 32 x 32 alphabetic, capable of 128 x 128 and color graphics and animation with addition of memory chips. Board/kit ..... \$29/\$129

### PROM Boards (unpopulated)

**450.** Includes on-board programmer, parallel I/O port, accepts up to 8k PROMs (6834) ..... \$29  
**455.** Includes parallel I/O port, accepts up to 4k PROMs (1702A) ..... \$29  
**460Z. MPU Expander.** Will accommodate Z-80 and a 6100 (PDP-8 equiv.) MPU, plus a color processor for multiprocessing under control of main 6502 MPU. Also accommodates four PIAs for control, plus several multiplexers and demultiplexers. Kit ..... \$125  
**460Z Subsystem.** Assembled 460Z plus eight-slot expansion chassis and 4k x 12 memory board .. \$990  
**CPU Board.** Can support 6501, 6502, 6502A, 6512, 6800, 6802, or 6802B MPUs, up to two PROMs (serial, video, and Floppy PROMs available), 1k RAM, serial and parallel I/O, buffering for OSI System boards.  
**400.** Bare board ..... \$29  
**414A.** MPU board kit with 6502A MPU, serial PROM monitor, serial port. Kit ..... \$149  
**414V.** Same, but with video PROM monitor, no serial port; requires 446 video board ..... \$134

### MODEL 500

Single-board computer designed for stand-alone use or as MPU module in larger system. Accepts 8k ROM, 4k RAM, serial port, 6502 MPU, buffering for expansion. (Also available with power supply and case, or in eight-slot Challenger case with power supply.) Compatible with OSI Challenger and 400. Wired, with 8k BASIC in ROM ..... \$298

## PAIA

### 8700 COMPUTER/CONTROLLER

Single-board computer, 6503 MPU, designed primarily for control applications. Includes hexadecimal keypad, connected by flat ribbon cable. Requires 5 V @ 1.2 A, 12 V @ 150 mA. Kit ..... \$150

## PARASITIC

### EQUINOX 100\*

8080A-MPU computer with 20-slot motherboard shielded against noise and crosstalk; 26-A, constant-voltage power supply. Integrated MPU/front panel (takes one slot) with octal keypad and display, reset switch, halt, run, reset, examine and deposit for all registers, memory locations and I/O devices; single-step and slow-step modes; display of any desired data (including time) under program control. Power-on reset. Case has sliding access panels, black vinyl and smoked plexiglass trim. Kit ..... \$699  
**Deluxe Hardware Kit No. 1.** Carrying handle, storage for detachable line cord, hinged cabinet top, tilt-up stand for desktop use, four additional edge connectors ..... \$100  
**Deluxe Hardware Kit No. 2.** Same, but with 18 edge connectors, to fully populate board ..... \$150  
**Edge Connectors.** Set of 18 ..... \$70

## POLYMORPHIC

### POLY-88\*

8080 MPU, in cabinet with five slots, 7-A power supply; up to four independently powered chassis may be plugged together; memory may be left on while boards in other cabinets are shut off for debugging. MPU board also includes on-board, real-time clock, eight-level vectored interrupts, 512 bytes of RAM, up to 3k PROM (2708 type) including 1k monitor; optional serial I/O port. Mini-card Cassette and Printer interfaces fit on MPU card. Resets to address zero on power-up.

**System 16.** Assembled, with MPU board, video cir-

cut card, cassette interface, 16k RAM, cabinet, power supply, fan, keyboard, 9-in. TV monitor, and



cassette recorder, with 11k BASIC and assembler software on cassette ..... \$2250  
**System 6.** Same, in kit form, less TV monitor and cassette recorder ..... \$1575  
**System 12.** Same as System 16, less TV monitor, cassette recorder, and memory. Wired ..... \$1175  
**System 2.** System 12 in kit form, less keyboard and fan ..... \$735  
**Cabinet.** With five-slot backplane and power supply, power and reset switches. Kit/wired ..... \$235/\$355  
**Printer Interface Card.** (Fits Poly-88 only). RS-232 or 20 mA. Kit/wired ..... \$65/\$80  
**Cassette Interface.** (Fits Poly-88 only). Kansas-City standard (300 or 600 baud) or Poly-Phase (1200 or 2400 baud). Kit wired ..... \$65/\$85

### PROCESSOR TECHNOLOGY

#### SOL-20 TERMINAL COMPUTER\*

8080-MPU computer system in housing with built-in keyboard. Includes 16-line, 64-character video in-

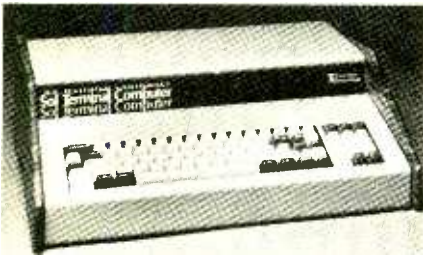

terface, 1k RAM, 1k ROM monitor, 85-key keyboard with upper- and lowercase, cursor keys and arithmetic keypad; 1200 bit/second CUTS cassette interface, two parallel and one serial I/O ports, 8.8-A power supply, fan, room for five expansion module boards. With BASIC (5k) and two video-game programs on cassette, SOLOS or SOLED personality module (see below) in ROM. Kit/wired ..... \$1095/\$1495  
**Sol-10.\*** Same, but with 70-key keyboard (15-key arithmetic pad optional), smaller power supply, 1k RAM, one module-board slot. Kit/wired ..... \$895/\$1295  
**Sol-PC.** As above, but single-board version, less power supply, cabinet, keyboard, but with 2k RAM. Kit/wired ..... \$575/\$745  
**Personality Modules.** Firmware optimizing SOL system for particular applications SOLOS (2k) for stand-alone computer use, SOLED (2k) for use as editing terminal. (Either included in price of SOL). SOLOS or SOLED Kit/wired ..... \$150/\$175  
**CONSOL.** 1k personality module. Available with SOL kit computers for \$100 less than above kit prices.

### QUAY

#### 90 MPS

Z-80 MPU, single-board computer, with on-board EPROM programmer. Features 4k to 64k on-board RAM (in 4k or 16k increments); 2.5-MHz clock; 1k EPROM monitor expandable to 7k EPROM total; 32 to 64 I/O lines, one serial (RS-232/20 mA) interface, up to four parallel ports (support Z-80 vectored mode), four programmable counter/timers (support Z-80 interrupt). External bus signals accessed via DIP 60-pin connectors. Requires +5 V (i 3.5-5 A, 5 V (i 100 mA-1.5 A, +12 V (i 300 mA-3 A, and +28 V (i 200 mA (for PROM 2708 programmer).  
**90-04MPS.** With 4k RAM, 32 I/O lines ..... \$695  
**94-04MPS.** Same, with 4-MHz clock ..... \$795

1978 Edition

**90-16MPS.** With 16k RAM, 64 I/O lines, four programmable counter/timers, 2.5-MHz clock ... \$1295  
**94-16MPS.** Same, with 4-MHz clock ..... \$1395

#### 80AI\*

Altair-bus compatible, Z-80 based computer including one serial interface (RS-232/20 mA), one parallel keyboard input. Automatic baud rate setting, 1k ROM monitor (sockets for 3k additional PROM). Usable as stand-alone computer, with suitable power supply. Kit/wired ..... \$450/\$600

### RADIO SHACK

#### TRS-80 MICROCOMPUTER

Z-80-MPU computer in compact keyboard housing; basic system includes 4k ROM with monitor



and Level I BASIC with string variables, video graphics and cassette save and load; 4k RAM; internally expandable to 12k ROM plus 16k RAM; total memory capability 62k; includes cassette I/O and video output interfaces; TRS-80 expansion bus for future peripherals; has cursor control, automatic scrolling and rebout. .... \$400  
 With 12-in CRT monitor (16 lines x 64 char), 300-baud cassette recorder, and backgammon/black jack software cassette ..... \$600

### RCA

#### COSMAC MICROTUTOR

1801 MPU, compact system with power supply, 256 bytes of RAM, two-digit LED hex display, and binary input switches. Expansion connector for I/O or memory. Wired ..... \$349

#### EVALUATION KIT

1802 MPU, single-board computer; 256-byte memory (expandable on board to 4k), 512-byte ROM monitor (space provided for additional ROM), serial (20 mA or RS-232) interface, binary LED display, battery-backup option made possible by CMOS circuitry; one eight-bit parallel I/O port. Continuous and single-step operation. Wired ..... \$249  
**Microterminal.** For COSMAC Evaluation Kit. Hex input keypad and eight-digit LED hex display. Wired ..... \$140

### SOUTHWEST TECH. PRODUCTS

#### 6800\*\*

Based on Motorola 6800 MPU and its family of support devices. Chassis; motherboard; memory card



with 4k bytes of eight-bit static RAM; serial 20-mA TTY/RS-232 interface card; power supply; crystal-controlled clock for baud rates from 110 to 1200; 6820 peripheral interface adapter (PIA); ROM-stored mini-operating system features tape load/dump routine, memory, and register examine and/or change function, and execute user's program command. Documentation package includes Motorola

6800 Programming Manual plus SWTP 200-page notebook, diagnostic and game programs, and application to join Motorola 6800 User Group. All boards are "plug in" type and contain on-board voltage regulators. Any combination of up to seven serial/parallel interface boards may be plugged in. Kit ..... \$395  
**MP-M.\*\*** 4k memory board, with 2k ..... \$65  
**2k expansion kit for MP-M** ..... \$35  
**MP-8M.\*\*** 8k memory ..... \$250  
**MP-L.\*\*** General-purpose parallel interface ..... \$35  
**MP-S.\*\*** General-purpose serial interface ..... \$35  
**MP-T.\*\*** Interrupt timer board ..... \$40

### STM SYSTEMS

#### BABY! 1

6502-MPU portable system (supplied in attache case). Includes 62-key keyboard; 1200-baud cassette interface (programmable to simulate any of the interfaces presently on the market), with standard and reverse-polarity cables; video interface displaying 16 lines by 32 characters, displays ASCII (128-character, upper- and lowercase), plus lowercase Greek characters; text-edit mode. Comes with 2k-4k on-board RAM, expandable to 65k; sockets for monitor ROM plus 3k PROM (2708) or 6k ROM (2316); 2k assembler ROM available. Maintenance contract available.

020923-001. Baby! 1 system with 2k RAM. Wired ..... \$850  
 020923-002. Same, with 4k ..... \$1000  
 020923-003. Same, with 4k RAM, 9-in. TV monitor, cassette recorder ..... \$1200  
 020923-004. Same, with 8k BASIC ROM and ROM card ..... \$1450  
 190923-001. Expansion card with serial I/O ..... \$250  
 130923-004. 4k Static RAM add-in ..... \$205  
 020119-008. ROM card with 8k BASIC (compatible with any 6502 system) ..... \$250  
 060419-001. Mini-floppy drive with power supply and controller ..... \$750  
 060419-004. Same with dual drive ..... \$1275



**FREE!**

*with your business card or send \$1.00 (refundable on 1st order)*

**LARGEST CATALOG IN ITS FIELD**

**Catalog Includes:**

- Manufacturer's Catalogs
- News about amazing breakthroughs in the Micro computer field
- \$2.00 Discount Certificate
- Discounts up to 90% on Used Equipment

**A Complete Computer System \$289**

- Fully Assembled
- Fully Tested
- Ten-day Money-back Guarantee

**KIM-1** — MOS Technology Computer Module  
 1K RAM, audio cassette interface, 15 bidirectional I/O lines, 24-key keyboard, and six-digit LED display  
**System Power Supply** (5V at 1.2A, 12V at 0.1A) with power line and switch  
**Software** — System Executive, Sample application programs  
**Documentation**

Visa & Master Charge accepted

**NEWMAN COMPUTER EXCHANGE**  
 1250 N. Main St. Ann Arbor, Mi. 48104  
 (313) 994-3200 Dept. EH

## TECHNICAL DESIGN LABS

### XITAN ALPHA 1\*

Z-80 MPU system with two serial I/O ports (RS-232 or 20 mA), 1200 baud audio-cassette interface, 2k RAM, 2k ROM monitor, 8-A power supply (operates on 110-120 V or 220-240 V a.c.), power-on clear and reset. In cabinet with eight card slots (six available for expansion), front-panel reset switch, rear-panel power switch to avoid accidental power-off. Kit/wired ..... \$769/\$1039

### XITAN ALPHA 2\*

As above, plus one 16k memory board (leaves five slots for system expansion) for 18k total RAM, one parallel I/O port, software including 8k BASIC, Text Output Processor, Zaple Text Editor, and Relocating Macro-Assembler. Kit/wired ..... \$1369/\$1749

## TECHNICO

### SUPER STARTER SYSTEM

Based on TI9900, 16-bit MPU; single-board computer with 1k PROM, 512 bytes RAM, EPROM programmer, serial (RS-232/20 mA) I/O on-board. Expandable to 2k RAM, 2k PROM, 2k EPROM on-board, to 65k total memory with expansion boards. Peripheral boards available include 32k byte memory expansion board, video/audio cassette interface, keyboards, floppy disk, power supply, interface board, chassis with limited or full front panel, CRT, printers. Kit/wired ..... \$299/\$399

## TEXAS INSTRUMENTS

### TM990/100M

Based on TMS9900, 16-bit MPU. Single-board computer with 1k, 16-bit words of EPROM with TI-BUG monitor, 256 × 16-bit RAM, expandable on board to 4k × 16 EPROM, 512 × 16-bit RAM. Parallel and serial (RS-232/20 mA) I/O, two programmable interval timers, 15 external hardware interrupts, and blank board area and extra sockets for prototyping. Will work with TI 990/4 prototyping system. Hexadecimal microterminal, four-slot chassis and other peripherals to come. Requires power supply (5 V @ 1.3 A, +12 V @ 0.2 A, -12 V @ 0.3 A). Wired ..... \$450

## VECTOR GRAPHIC

### VECTOR 1\*

8080 MPU, 18-slot computer (with six connectors installed), 20-A power supply, whisper fan, PROM/



RAM board with 1k RAM, room for 2k 1702A ROM, 512-byte monitor for use with Tarbell cassette and Altair, IMSAI, or Polymorphic I/O boards. Kit/wired ..... \$619/\$849  
 Without PROM/RAM ..... \$519/\$619  
 Without CPU ..... \$499/\$699  
 Without CPU or PROM/RAM ..... \$349/\$499

## WESTERN DATA SYSTEMS

### DATA HANDLER\*

6502-MPU computer with variable-speed clock,



2400-baud cassette interface, 1k on-board RAM, one parallel I/O port, hex keypad entry with binary display, I/O control switches; solder-pads provided

for connection to a single Altair-bus peripheral board or motherboard for multiple-board use. In wood case. Requires power supply (under 2 A @ 5 V). Available as unpopulated "bare-bones" kit/kit with all components/assembled ... \$80/\$200/\$235  
**Metal Case.** Black anodized, with tracks for Data Handler and expansion board ..... \$19  
**Dust Cover.** Hinged plexiglass dust cover with cut-out for switch and keypad access ..... \$14  
**Expansion Board.** Includes 12k RAM; 1k EPROM with I/O routines, etc.; 80-character, 25-line video interface with upper- and lowercase, Greek and some graphics characters; interface for mini-floppy disk drive ..... \$350

## WINTEK

### WINCE MICRO MODULES

6800-MPU, modular system, consisting of the following:

#### Wince Control Module

6800-MPU board with 128 bytes RAM, one serial or parallel port, space for up to 512 bytes RAM, one serial and two parallel ports. Minimum configuration (128 bytes, one port) ..... \$149  
 Maximum configuration (512 bytes, three ports) ..... \$199

#### Back-Planes

Four-socket ..... \$50  
 Eight-socket ..... \$90

#### Power Supplies

5 V @ 2 A, ±12 V @ 200 mA ..... \$85  
 5 V @ 5 A, ±12 V @ 1.6 A ..... \$170

#### Console Module

Keyboard and digital displays; provision for up to 25 key switches, up to 16 display digits. Optional real-time clock provides interrupts.

Less keys, displays, clock ..... \$139  
 For real-time clock, add ..... \$29  
 For each display digit add ..... \$10  
 For each key switch add ..... \$8

#### Dynamic RAM Memories

RAM refresh module ..... \$99  
 RAM board with: 4k ..... \$275  
 RAM board with: 8k ..... \$399  
 RAM board with: 12k ..... \$575  
 RAM board with: 16k ..... \$699

#### CMOS RAM/Battery Module

With battery backup to protect memory contents during power off. Accommodates up to 2k bytes. With 256 bytes ..... \$399  
 With 2k bytes ..... \$899

**ROM Module.** For up to 16k EPROM (2708) or ROM ..... \$82

**EPROM Programmer Module** with software on cassette or paper tape ..... \$199

Programmer software on 2708 EPROM ..... \$99

**FANTOM-II.** 1k ROM monitor ..... \$29

#### Interfaces

**RS-232C.** For Control Module serial port ..... \$39

**Cassette Interface.** 300 and 2400 baud; shares Control Module serial port with RS-232 ..... \$139

**Modem.** For data communications via telephone line; includes touch-tone dialing tones, auto receive ..... \$1499

**Floppy Disk Interface.** for ICOM/PERTEC ..... \$119

**Analog interface.** Less MUX, ADC, DAC ..... \$99

**16-channel MUX** ..... \$139

**Eight-bit DAC** (two, max). Each ..... \$59

**Eight-, 10- or 12-bit ADC** ..... \$149

**Driver/Sensor Module.** For external device control (by relay) and sensing. Supplied less drivers and sensors, but with 16 ports ..... \$69

**Driver** (requires one port) ..... \$3

**Sensor** (requires two ports) ..... \$12

#### SYSTEM 68

Cabinet, power supply, card rack, and back plane for Wince modules, plus one RS-232 adapter for control board's serial port.

With four-module backplane and power supply ..... \$599

With eight-module backplane and power supply ..... \$728

## WYLE

### 8080-MPU SYSTEM

Totally modular, on 3¼" × 4½" plug-boards. Mount in card files with from seven to 28 slots, including 19-in. rack-mount versions, or 84-slot card drawer for 19-in. rack. System options include: RAM

and EPROM memory; parallel, serial, analog, and opto-isolator I/O; priority interrupt; time clock; front panel; interface for DEC PDP-11; power supply; paper-tape reader; wrapped-wire module; plus a wide variety of plug-compatible individual logic modules. Price depends on system configuration.

## ZILOG

### Z-80-MCB

Z-80 MPU, single-board computer with 4k RAM (16k optional), 4k ROM or PROM (monitor firmware available in ½k, 1k, 2k and 4k versions, ½k standard), serial port, parallel I/O. Wired ..... \$495

**Z80-RMB.** 16k RAM board (4k provided) ..... \$750

**Z80-CPB/PROM.** Programmer for 2708 and 7620 ..... \$575

**Z80-VDB.** Video display board, 24 lines × 80 characters, uppercase ASCII ..... \$475

**Z80-IOB.** Four-port parallel I/O ..... \$350

**Z80-SIB.** Serial I/O board, four full-duplex ports ..... \$375

**Z80-MCS.** System with card cage, power supply, 16k RAM, 3k PROM, dual floppy disk drive, cabinet ..... \$590

## COMPUTER PERIPHERALS

\*Fits Altair bus. See Computers section for computers accepting this equipment directly.

\*\*Fits SWTP 6800 bus.

## AXIOM

### EX-800P PRINTER

80-column line printer, 160 characters per second. Dot-matrix on 5-in-wide electrosensitive paper; 96-character ASCII character set (includes lowercase), character size variable 5-20 characters/inch under program control; low-paper detector, bell, case, power supply. Parallel interface ..... \$655

**EX-800S.** Same with RS-232 serial interface, larger input buffer ..... \$740

### PLOTTER

All features of EX-800, plus graphic plotting capability with 512 dots per line; 16 rows per second. Print-head position feedback to computer ..... \$795

## CENTER FOR STUDY OF FUTURE

### SELECTRIC PRINTER INTERFACE

Drives IBM Selectric terminals with 24-V, 30-msec-pulse solenoids, such as Dura 1021 and 1041, office Selectrics with Tycom Edityper adapters, etc. (Can be modified for higher-voltage solenoids.) Includes RS-232 input interface for seven-bit ASCII, conversion PROM (no special software required), hardware delay for carriage return, tab, and shift. Requires 134 or 110 baud I/O or CFSOTF SIO card. Output only—requires separate keyboard as input.

**Select-A.** Output interface card with conversion PROM, solenoid drivers. Requires +5 V, -12 V, and solenoid voltage (+5 V, +24 V or +36 V), plus indicator lights and switches. Kit/wired .. \$325/\$395

**Select-B.** Same, with +5 V and -12 V supplies on card, plus externally mounting transformer. Kit/wired ..... \$375/\$455

**Select-C.** Same as "B," with +24-V solenoid supply. Kit/wired ..... \$395/\$495

## COMPUTER CONVERTOR

### CONVERTOR 8000 VIDEO TERMINAL

Video terminal, 24-line, available for 40- or 80-character lines, with and without built-in acoustic coupler. ASCII uppercase 64-character set. RS-232 interface, 110-300 baud; automatic wrap-around and scrolling. Wired.

**400.** 40-character ..... \$595

**401.** Same, with coupler ..... \$705

**800.** 80-character ..... \$695

**801.** Same, with coupler ..... \$805

**900.** 80-character CONVERTOR in 12-in monitor, less keyboard ..... \$750

**9000.** As above, but with keyboard assembly and cable ..... \$825

**Tape recorder connections** for 401, 801, for offline storage ..... \$30

### MODEL 100 KEYBOARD

Uppercase ASCII (53 keys), in case ..... \$129

**MODEL 200 MONITOR TV.**  
12-in CRT, modified for 80-character line ..... \$175  
**Model 300 Acoustic Coupler.** In case ..... \$175

## CROMEMCO

### JOYSTICK CONSOLE

Joystick (2-axis) with speaker and amplifier, plus four user-defined pushbutton switches. Joysticks

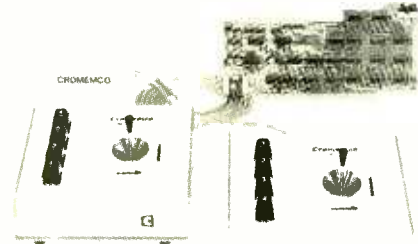

± 2 V each axis, spring return to center. For games, graphics, and similar applications. For use with Cromemco D+7A\* or similar analog interfaces. Joystick console. Kit/wired ..... \$65/\$95

## CYBERNETIC MICRO SYSTEMS

### MODEL 34 SUPER PRINTER

Dot matrix impact printer; 34-column; makes multiple copies. Full 96-character, upper/lowercase ASCII font, expanded print available, two-color (red/blue) printing selectable. Highspeed, 120 LPM. Requires parallel interface. Wired ..... \$995

## THE DIGITAL GROUP

### KEYBOARD

Keyboard with 76 keys, including 128-character ASCII, numeric pad, lighted uppercase key, cursor controls, two-key rollover. Requires +5 V.

**KEY-1.** Keyboard with interface cable ..... \$150

**KEY&CB.** With cabinet. Kit/wired ..... \$180/\$205

### PT96-COMP PRINTER

Impact printer, 96-column, 120-character/second, 12 characters per inch, six inches/inc. Character set and pitch variable under software control. Uses 8½-in roll, fanfold, or cut paper. Requires parallel I/O. With cabinet, power supply, and cabinet. (Also available separately.) Kit/wired ..... \$595/\$675

## ECONOMY TERMINALS

### ET1

Displays 24 lines of 80 characters, upper-case ASCII (transmits upper and lower) on 12-in CRT. RS-232 and 20-mA interfaces; 63-key keyboard; scroll and page modes; 16 selectable baud rates to 19,200; blinking underline cursor, addressable; automatic repeat on all keys; tab fixed every eight characters. Wired ..... \$895

## EDITPER SYSTEMS

### IBM SELECTRIC I/O KIT

Converts IBM Selectric and Selectric II typewriters for use as computer I/O terminals. Kit includes solenoids, switches, clutch, interconnecting-circuit board, harness, and connector; user must furnish solenoid drives and timing. Optional power supply, drivers, and Selectric/ASCII ROM available. Kit, less options ..... \$395

## ELECTRONIC PRODUCT ASSOCIATES

### IMP-1A PRINTER

Line printer, 40-column, bidirectional, 5 × 7 dot-matrix impact type, 50 characters per second with 80 char/sec bursts. Prints 12-char/inch on 3 7/8-in paper. .... \$450

**IMP-68X.** Interface for EPA Micro-68b computer. \$22

**IMP-EXOR.** Interface for EXORcisor ..... \$22

**IMP-ALT/IMS.\*** Interface for Altair, etc ..... \$79

### FLOPPY DISK

Floppy disk systems for 6800 MPU. IBM-compatible format, 250k bytes per disk. With cabinet and power supplies.

**Single-Drive System** ..... \$2595

**Dual-Drive System** ..... \$3295

## EXPANDOR

### "BLACK BOX" PRINTER

Prints 10 char/sec, 80 char/line, uppercase ASCII

set, on 8½-in paper. For friction or sprocket-fed paper, parallel port. Line spacing, six lines/inch. Impact printer, can make multiple copies (six max.)  
Wired ..... \$296  
Cover ..... \$30

## HAL

### KSR ASCII/BAUDOT VIDEO DISPLAY

Keyboard send/receive (KSR) and read-only (RO) versions. Choice of five-level Baudot or eight-level ASCII data. Uses 8080A for full cursor positioning and editing capability (KSR), display 1152 characters in 16 lines of 72. Has RS-232 and current-loop ports; Baudot from 45 baud (60 wpm) to 100 baud (132 wpm), ASCII from 110 to 1200 baud. Has 6.1-MHz bandwidth, 1-V EIA video output, CRT with 11-inch diagonal, 5 × 7 dot matrix. Keyboard: 52-key ASCII, shift, control, N-rollover, Quick Brown Fox test message, programmable character string to 255 characters. Bell tone provided. Scrolls from top down, full cursor control, word wrap-around ..... \$1195

**DS-3000 RO ASCII/Baudot** ..... \$1075

### DS-4000 KSR (ASCII) VIDEO DISPLAY TERMINAL

Serial ASCII (eight-level) code. Has RS-232 and current-loop ports; KSR version 110 to 1200 baud, 150 baud available on RO model. Word format is ASCII 10 or 11-unit code, parity odd, even or mark. Video 1-V, neg. sync, 6.1-MHz bandwidth, timing is crystal-controlled. Display is 1280 characters in 5 × 7 dot format, 16 lines by 80 characters per line, 11-in CRT. Has 8080A processor for full cursor control and text editing. Transmission modes are character by character, line, block, all switchable. Printer interface is RS-232 level. Bell tone is provided. Keyboard is 52-key standard ASCII with shift, control, N-rollover. DS-4000 ..... \$1195

### RVD-2110 MONITOR/TV

Solid-state, 9-in-diagonal screen, BNC connector for 75-ohm video input. As TV, operates on all channels ..... \$150

### RVD-910 VIDEO MONITOR

Solid-state, 9-in-diagonal screen. Front panel includes brightness, focus, on/off, contrast, vertical hold/size, horizontal size/reduce size. Rear apron has horizontal size, two video inputs, int/ext sync, two ext sync inputs, 75-ohm termination. Bandwidth to 15 MHz. Linearity better than 2% overall. Resolution greater than 1000 lines in central 80% of screen ..... \$325

## HEATH

### H9 CRT TERMINAL

Displays 12 lines of 80 characters on 12-in screen, formattable to four columns of 12 lines × 20 characters; cursor control; batch transmit; plot mode; 110-9600 baud; serial RS-232, 20 mA, and TTL interfaces. Kit ..... \$530

### H10 PAPER TAPE READER/PUNCH

Uses standard 1-in wide paper tape (roll or fanfold); reads at 50 char/sec; punches at 10 char/sec; punch and reader circuits are independent and may be operated simultaneously; copy mode for tape duplication; power supply; parallel TTL interface. Kit ..... \$350

## ICOM

### FRUGAL FLOPPY\*

Single-drive diskette system with controller; 256k-byte, IBM-3740 format, less power supply cabinet, and interface (see interfaces below). Assembled ..... \$1195

**Additional drive** ..... \$665

**FD3711.** Similar in cabinet with power supply and room for second drive ..... \$2350

**Second drive for above** ..... \$710

**S100 interface\*** for above systems. Wired ..... \$300

### MICROFLOPPY\*

71k-byte, single-drive mini-floppy system, with controller and Altair-bus interface, power supply, cabinet, all cables and connectors, and software (including DOS and BASIC). Controller can handle up to three drives. Assembled ..... \$1095

**Additional drives** ..... \$649

## IMSAI

### BBC-5\* INTELLIGENT BREADBOARD

Circuit-development breadboard interfacing to IMSAI 8080 or other Altair-bus computers. Requires P106-6 interface. Kit/wired ..... \$435/\$635

**BBC-3.** Smaller breadboard, expandable to BBC-5. Requires P106-3 I/O. Kit/wired ..... \$325/\$532

**Key-1.** ASCII keyboard, upper-/lowercase, for parallel I/O ..... \$199

## INTERNATIONAL DATA SYSTEMS

### TSM TEMPERATURE-SENSING MODULE

Self-contained in minibox. Requires only three-wire connection (parallel I/O) to computer system. Also interfaces with IDS 88-UFC Frequency Counter Module (see Module Boards). Battery-powered (may be turned on and off by computer); uses thermistor probe which may be mounted up to 20 feet from TSM. Measures 0-120°F. (-18° to +49° C.), resolution better than 0.1°C. All needed software included. Kit/wired ..... \$24/\$44

### DAC-8 DIGITAL TO ANALOG CONVERTER

Self-contained in minibox; requires one eight-bit output port. Designed for applications requiring generation of audio frequencies (0-20 kHz), and applications requiring eight-bits of resolution for analog voltage control. Powered by internal 9-V battery. With software. Kit/wired ..... \$19/\$34

## LEAR SIEGLER

### ADM-3a "DUMB TERMINAL"

CRT terminal; 80 characters × 24 lines on built-in, 12-in-diagonal screen. Standard 64-character ASCII uppercase character set supplied; 90-character upper-/lowercase set optional. Switch-selectable cursor modes: Underline cursor homing to lower left of screen, with automatic scrolling; and page mode with reverse-character cursor homing to upper left. End-of-line tone. Full and half-duplex modes, 11 communication rates from 75 to 19,200 baud. Switch-selectable RS-232 and 20-mA interface to computer; extension RS-232C port for printer, recorder, or additional terminals (20 mA optional). Cursor can be directly addressed to any part of screen by keyboard or computer, in page mode. Kit ..... \$875

**Lowercase option** ..... \$50

**Arithmetic keypad,** with cable and connector ..... \$85

## MICON

### CAPTAIN VIDEO TERMINAL

Compact terminals, with Teletype-compatible keyboard, power supply, RS232 interface, 110-9600 baud selectable speeds, choice of eight colors.

**KDM/1.** With internal display, one line × 32 characters ..... \$490

**KDM/2.** For 16-line, 64-character display on video monitor or TV set (RF coupler supplied), cursor ..... \$625

**KDM/3.** For 24-line, 80-character display on CRT monitor ..... \$850

**Pocketerm.** Similar to KDM/1, but with built-in modem and acoustic coupler for data transmission by phone ..... \$995

**Cassetterm.** Similar to Pocketerm, but with built-in mini-cassette data recorder to store data for high-speed transmission via built-in acoustic coupler ..... \$1445

## MICRO COMPUTER DEVICES

### SELECTERM

IBM Selectric II typewriter, adapted for use as printer for computer output. Uses ASCII code, parallel port interface. Supplied with ASCII character ball; 31 other type-font balls available, including OCR, script, and italics. Full upper- and lowercase. Retains IBM warranty and is still usable as typewriter, though keyboard does not communicate to computer. Standard is 10 char/in, 13-in writing line; 12 char/in (155/line) available on special order, no extra charge. Wired and tested ..... \$1295

**Dual-pitch option** (10 and 12 char/in) ..... \$100

**Correction feature** ..... \$100

**Computer-controlled backspace** ..... \$25

**Computer-controlled index** (vertical tab) ..... \$25

## MICRO DESIGNS

**MODEL 100 FORMATTED DIGITAL CASSETTE\***

Digitally controlled single-drive transport and interface for standard Philips-type compact cassettes. Stores one-half megabyte per cassette, transfers data at 1000 bytes/sec, searches for individual records at 120-in/sec (under 28 sec per side with C-60 cassette). Tape transport under computer control; COS software allows file management with named binary and symbolic files, IBM-compatible floppy-disk format. Altair-bus interface has bootstrap in ROM. Wired only ..... \$600  
**Model 200.** Dual drive ..... \$875

### MICROCOMPUTER ASSOCIATES

#### VIDEO TERMINAL VT-100

Keyboard terminal for connection to TV set. Uses RS-232 or 20-mA interface. Typewriter-style keyboard with upper- and lowercase ASCII, control functions, rotary baud-rate switch (to 9600 baud), two-key rollover. Displays 32-character, 16-line page; two-page memory supplied (1k), expandable to 16 pages. Data can be edited on-screen before transfer to computer. Cursor controllable ..... \$595

### MIDWEST SCIENTIFIC INSTRUMENTS

#### FD-8 FLOPPY-DISK

300k bytes per disk. Single-drive system interfaces to any parallel port (parallel interface card available for SWTP6800\*\*). Read after write for error-check. Complete disk operating system available for 6800-based systems; disk-driver and Mini-DOS routines may be integrated with BASIC for 8080 systems. Includes controller for up to four drives. Kit/wired ..... \$1150/\$1395  
**Dual-Drive System.** Kit/wired ..... \$1950/\$2295  
**MINI-DOS system on PROM (1702)** ..... \$250  
**FDOS/BASIC,** on diskette ..... \$65  
**FDOS Bootstrap only,** 1702 PROM ..... \$125  
**Additional drives** ..... \$900  
**PIA-1.\*\*** Parallel interface card for SWTP 6800 computer system. Kit, less diodes ..... \$50

#### CRT-1 TERMINAL

24 line x 80 characters, full ASCII upper-/lowercase. Parallel interface. Scrolling and paging, with MSI PROM monitor for 6800 (see Module Boards). Can use PIA-1\*\* (see above). Includes controller board, keyboard, cabinet, CRT, power supply. Kit ..... \$825

#### MCRT-E TVT ENCLOSURES

Holds terminal, keyboard, and CRT; as used in CRT-1 terminal. Removable keyboard mounting routed to accept SWTP KBD-5 keyboard ..... \$90

#### TVTE TVT ENCLOSURE

Designed for SWTP CT-1024 TV typewriter. Keyboard plate routed for SWTP KBD-5 keyboard, with space at right for additional control keys or number pad; space on top for setting CRT monitor ..... \$55

#### KDE TVT ENCLOSURE

Designed for CT-1024 or similar terminals; lower keyboard enclosure plus upper section to house 12-in CRT monitor ..... \$95  
**Keyboard or CRT enclosure.** Each ..... \$50

### 780 HIGH-SPEED PRINTER

Dot-matrix impact printer (five copies max.); 80 char/line, six lines/in, 60 char/sec. Sprocket-fed paper up to 9½-in wide. Buffered input. Full alphanumeric uppercase, normal, and elongated characters. Less interface ..... \$1495

### PROM PROGRAMMER/VERIFIER

Programs PROMs directly from computer memory via parallel port. Reads and compares PROM after writing to verify contents; displays discrepancies and error message on terminal.  
**PR-1.** For 1702A PROMs. Wired ..... \$325  
**PR-2.** For 2708 PROMs. Wired ..... \$325

### SW1 SCANNING WAND

Optical bar code scanner for programs published in optic bar code. Requires +12 V, parallel interface ..... \$125

### AC-1 POWER CONTROLLER

Allows TTL-logic levels to turn 110-V a.c. powered devices on and off. Opto-isolated. Has two 110-V a.c. outlets, plus manual turn-on switch. Returns zero-crossing signal to computer, allowing power to be turned on at desired point in cycle for resistive or inductive loads. Kit ..... \$50

### MINITERM ASSOCIATES

#### WORD-PROCESSING KEYBOARD

Ninety keys, with tactile feedback, 100-million-operation-guaranteed keyswitches. Upper- and lowercase, 12 function keys, numeric pad, four on/off keys, and auto-repeat. Wired, in enclosure ..... \$235

### MITS

#### ALTAIR FLOPPY DISK SYSTEM\*

Nonvolatile fast-access memory, stores over 300,000 bytes per disk, 4k bits on each of 77 tracks. Average read/write time 400 msec; data transfer rate 250k bits per second. Disk controller consists of two PC boards that fit the Altair bus, connects to the disk drive via a 37-pin connector. The 88-DCDD consists of the disk controller and one disk drive. Kit/assembly ..... \$1425/\$1715  
**88-DISC.** Additional disk drive, in cabinet ..... \$1215/\$1355

#### ALTAIR MINIDISC\*

Similar to above, but uses smaller, 5-in mini-floppy disk, up to 72k bytes per disk, transfer rate 125k bits/sec. Requires two slots in Altair bus for controller. Wired ..... \$1150

#### ALTAIR C-700 PRINTER\*

Matrix impact printer (up to five copies); prints 132 columns of 5 x 7 dot-matrix characters (64-character ASCII uppercase), 10 characters per inch, at a rate of 60 char/sec (26 lines/min). Character width adjustable to provide 66 columns of double-width characters. Printed lines spaced six lines/in. Prints bidirectionally to save carriage-return time. Interface requires one slot in the Altair computer bus. Wired ..... \$2375

### ALTAIR 7000 GRAPHICS/PRINTER

Prints upper- and lowercase characters or graphics on electro-sensitive paper. Requires one parallel port, plus MITS Extended or Disk Extended BASIC with 7000 option (listings of plotting subroutines

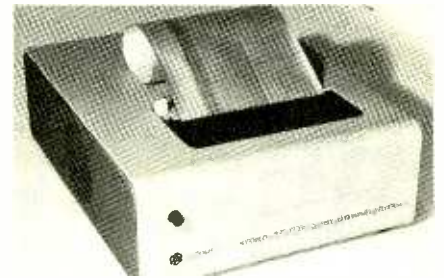

supplied with printer). Prints lines of 20, 40, or 80 characters within a 4-in margin, @ 160 char/sec, 120 lines/min. Plotting speed, two lines/sec, eight dots (vertical) per line. Graphics resolution, 80 dots/in with internal timing, better than 128 dots/in with external timing (horizontal); vertical resolution 65 dots/in. Produces either a distinct outline, or shaded graphics, as required. Wired ..... \$785

### MOTOROLA

#### M68FD3712 EXORDISK

Dual floppy-disk mass storage system for EXORciser and compatible computers. Up to 256 k bytes per diskette; IBM-3740 compatible ..... \$3000

#### M68R680 EXORTAPE

High-speed paper-tape reader (250 char/sec); may be daisy-chained with EXORDisk ..... \$895

#### M68IFC INTERFACE

For EXORDisk or EXORTape ..... \$300

### M&R

#### PENNYWHISTLE 103 MODEM

May be used as acoustic coupler (with telephone handset) or wired directly into the telephone via a di-

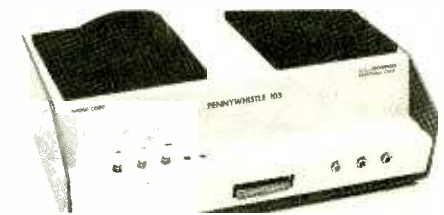

rect-access adapter. Operates in both half-duplex (unidirectional) or full-duplex (bidirectional) modes. Records data to and from audio tape; communicates directly with another modem and terminal; can record data from a remote source over the phone line and enter the data into the memory of a computer. Kit ..... \$130

### NATIONAL MULTIPLEX

#### 3M3 DIGITAL DATA RECORDER

Uses 3M Data Cartridge, Model DC-300; records nearly two megabytes per cartridge, on four tracks, phase encoded, at 9600 baud. Has inter-record gap light, full software or manual control of all functions including fast-forward and rewind; has high-speed search for inter-record gap. Comes with software. Uses "Uniboard" cartridge drive construction. Requires serial I/O port with two parallel bits for control. 2SIO(R) board (see below) recommended for Altair-bus systems. Wired ..... \$220.00

#### CC-8 DIGITAL COMPACT-CASSETTE RECORDER

Direct digital recorder (no audio-cassette interface required) using standard Philips-type Compact Cassettes. Handshake signals when motor is up to speed. RS-232 I/O standard, TTL optional (user changeable); speed adjustable. Uses Binary NRZ asynchronous single-track digital recording on half-track format (flip cassette over for second track). Adaptable for 12-V operation. Use of 2SIO(R) board recommended for Altair-bus computers. Motor

## WHAT'S YOUR BAG?

Whatever it is, we'll fill it . . .



with anything and everything. Choose from a complete line of specialized tool kits and cases.

Or . . . try our **DESIGN-A-KIT** for a great way to customize your own kits. Take your pick from our 10,000 item inventory.

FREE CATALOG

**TECHNI-TOOL INC.** Apollo Rd., Plymouth Mtg., Pa. 19462 (215) 825-4990



start/stop by remote or local control. Fast forward and rewind. Manual only. Wired ..... \$175

**2SIO(R)\***

Altair-bus board with I/O connections for 3M3, CC-8, or audio cassette recorder, one terminal interface, plus ROM monitor with read/write/search routines. Kit/wired ..... \$160/\$190

**NORTH STAR**

**MPS-A MICRO-DISK SYSTEM\***

Uses Shugart Mini-Floppy drive, 100k bytes per diskette. Controller on one Altair-bus board, with bootstrap software in PROM. Supplied with DOS and disk BASIC software, all connectors and cables. Power requirements: 9 A @ 5 V, 1.6 A @ 12 V, can be supplied by computer or optional power supply. Drive assembled, controller available kit/wired ..... \$699/\$799  
**Power Supply** ..... \$39  
**Cabinet** ..... \$39  
**Additional drive** ..... \$425

**OHIO SCIENTIFIC**

**FLOPPY DISK**

For OSI Challenger, 400-series or 500-series computers. Single-drive unit available kit or wired, with cables, controller board (bare, in kit version), and disk operating system on diskette; BASIC available. Dual drive unit wired only. Single kit/wired/dual wired ..... \$599/\$990/\$1590  
**Floppy Disk bootstrap PROM optional** ..... \$60

**OLIVER**

**OP-80A PAPER TAPE READER**

High-speed optical tape reader; no moving parts. Reads punched paper tape up to 5000 char/sec. Includes optical sensor array, high-speed data buffers, handshake logic for interfacing with parallel I/O. Kit/wired ..... \$75/\$95

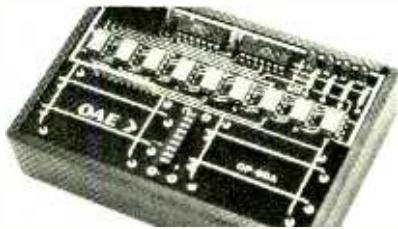

**2708/16 PROM PROGRAMMER**

Programs 2708 and new 2716 PROMs. Interfaces to parallel port; requires very little software—data is dumped via the output port to program the ROM. Requires 1-A, 8-12-V power supply. Takes less than 100 seconds to program 2708, less than 200 for 2716. Kit/wired ..... \$249/\$299  
**Kit, less regulators** ..... \$199

**PAIA**

**8782 DIGITALLY ENCODED KEYBOARD**

Piano-type, 37-note keyboard for computers and electronic music systems. Includes power supply

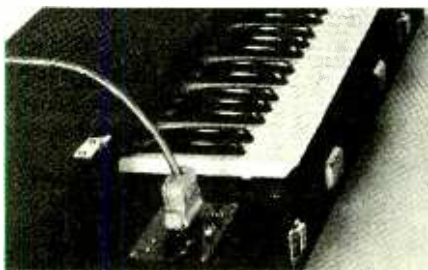

and software instructions. Can be used as infinite-hold Sample-and-Hold device, with PAIA 8780 D/A converter. Kit ..... \$110

**8780 DIGITAL-ANALOG CONVERTER**

Equally tempered D/A converter; based on multiplying principle, rather than conventional ladder-type

circuits, to generate stair-step exponential function required for equally tempered musical intervals. Generates over five octaves of control voltage from only six bits of data; remaining two bits usable for trigger flags, range extensions, or micro-tonal tuning. Interfaces to any microprocessor, with or without handshaking logic. Can be used with 8782 keyboard for infinite-hold Sample-and-Hold. Kit ..... \$35  
 In addition to computer, above modules interface to a complete series of synthesizer-module kits.

**PERIPHERAL VISION**

**FLOPPY DISK\***

Floppy disk system with 300k bytes (formatted) and Altair-bus controller. Hard-sectored. Controller for up to eight drives; can load head of more than one drive at a time, for more efficient file copying. Interface card has bootstrap in ROM, jumper address to any 8k boundary. Includes DOS on disk with source listing.

**FLHS-KC1/-AC1.\*** Complete assembled drive and interface. Kit/wired ..... \$750/\$850  
**PWR-1 K/A.** Power supply for above. Kit/wired ..... \$45/\$65  
**CBF-1.** Single-drive cabinet ..... \$85  
**FLHS-P-1.** Hard-sectored floppy drive only ..... \$550  
**IFF.\*** Floppy interface card, with software. Kit/wired ..... \$245/\$345

**PERSCI**

**1070 DISKETTE INTELLIGENT CONTROLLER**

Diskette drive controller with 8080-MPU "intelligence" built in. Communicates by file name, assumes all housekeeping functions usually performed by the computer's MPU; allows data transfer between diskette and MPU interface or optional RS-232 interface. ROM options allow copy-data transfer between diskettes. Requires interface. Wired with Model 70 single drive ..... \$1195  
**Wired, with Model 270 dual drive** ..... \$1575

**PROCESSOR TECHNOLOGY**

**HELIOS II DISK SYSTEM\***

Dual-drive diskette system with DOS, power supply, Altair-bus controller board, case, cables, documentation, system diskette with DOS, and FOCAL interpreter on disk. Capacity 386k bytes per diskette, over 750k per system; capacity can be raised to 1.5 M bytes with additional dual drive. Kit/wired ..... \$1895/\$2295  
**BASIC on diskette** ..... \$50

**PROKOTRONICS**

**PTR-II PAPER TAPE READER**

High-speed optical tape reader; no moving parts (tape is fed hand-over-hand). Requires parallel interface, user-supplied light source. Kit/wired ..... \$54/\$68

**PTR-M.** Motorized version of above; low-voltage motor can be controlled by computer, allowing start, stop, and reverse feed under software control; user-supplied light-source required. Wired ..... \$115

**RADIO SHACK**

**ARCHER KEYBOARD ENCODER**

Alphanumeric keyboard, 63 keys, with ASCII output, for parallel interface. Includes repeat key, latch outputs, shift and shift lock, extra control keys. Can handle 833 char/min; repeat-key rate 208 char/in. Requires 5-V d.c. @ 400 mA. Project-Board kit, available as board only with instructions, or as complete kit less hardware, case, and power supply. Board/kit ..... \$15/\$58

**GEORGE RISK INDUSTRIES**

**753 KEYBOARD KIT**

Keyboard, 53 keys, with two-key rollover, upper-case lockout, three user-definable keys. Selectable parity, data, and strobe inversion. Kit/wired ..... \$60/\$71  
**Model 701.** Enclosure ..... \$15

**RO-CHE SYSTEMS**

**MULTI-CASSETTE CONTROLLER**

Controls four audio cassette recorders, including write, read, and start/stop, through one interface. Plugs directly into and is controlled through, the Tar-

bell\* cassette interface; optional mod kit for use with MITS Altair\* ACR. (See Module Boards for both.) Includes operating system software with cassette selection, multiple files with update and merge, split and duplicate; two-pass assembler, record compression, and other useful subroutine. Optional software: text file editor, I/O drivers for cassette, BASIC patches.

**MBB-4B.** With four cassette ports. Kit/wired ..... \$125/\$175  
**MBB-2B.** With two ports ..... \$95/\$135  
**MBB-RA.** Two-port add-on ..... \$32  
**MBB-MTS.** Altair Interface Mod ..... \$17  
**Text File Editor and manual** ..... \$10  
**I/O drivers on cassette, BASIC patches** ..... \$10

**SCOPE DATA**

**SERIES 200 PRINTERS**

Non-impact printers using electro-sensitive paper. Up to 80 char/line, 120 char/sec (optional, 240 char/sec). Prints 96-character set (uppercase forms in two sizes), 10 char/in, 6 lines/in. Has print-density control, paper-out alarm; uses 8 1/2-in wide paper on 300-ft roll. Interfaces to RS-232, 20 mA, and TTL serial ports or parallel TTL.  
**200-RO.** Receive-only version ..... \$1595  
**200-KSR.** Keyboard send/receive version ..... \$1895  
**256-character FIFO buffer option for 1200 baud** .. \$364  
**Expanded character set option** ..... \$295  
**300-baud acoustic coupler option** ..... \$275  
**Compressed character option 132 char/line, 16.5 char/in** ..... \$150

**SHARP & ASSOCIATES**

**SELECTRIC CONVERSION KITS**

Converts IBM Selectric I or Selectric II typewriter for use as I/O terminal; unit remains usable as typewriter. Includes solenoids and opto-electronic key sensors.

**SK-1.** Conversion hardware and manual; requires 10 parallel I/O lines for interface, 12-V power supply ..... \$148  
**SK-2.** Same, with 12-V supply and TTL compatibility



## BUILD YOUR OWN TROUBLE FREE OSCILLOSCOPE

Engineered by Heath Co. and Manufactured for use by RCA Institutes

**Ideal and Inexpensive for Professional Service Technicians, Students, and Experimenters**

A five-inch scope, designed for the needs of service technicians — a stable instrument operated at a high degree of dependability — a trouble-free performer. Formerly RCA Inst. Model 825

**Easy to assemble.** Two modern printed circuit boards to reduce point-to-point wiring. Combined simple instructions and operating manual included.

Frequency response from 3 Hz to 5 MHz, +1.5 dB. The response at 3.58 MHz color TV carrier is -2.2 dB. Special features include two preset adjustments to facilitate instantaneous oscillator lock-in for TV vertical and horizontal sweep circuits. Test communication equipment (including CB's), Hi-Fi's, Radios and TV's. Order your scope.

**Was \$118.95 — Now only \$69.95**

New Jersey Residents add 5% sales tax  
Inquire about other products.

---

**ETI Products Dept 2640-107 Technical Home  
Study Schools Little Falls, N.J. 07424**

Enclosed is my check for \$69.95 Send me Oscilloscope Kit, postpaid.

Name \_\_\_\_\_ (Please print)

Address \_\_\_\_\_

City \_\_\_\_\_ State \_\_\_\_\_ Zip \_\_\_\_\_

Visa/BankAmericard     Mastercharge

American Express         Carte Blanche

Card Number \_\_\_\_\_

Inter-bank # \_\_\_\_\_ Expiration \_\_\_\_\_

SK-3. Includes controller for 110 or 300 baud serial I/O, RS-232 interface, plus parallel I/O port for paper-tape reader/punch. Has option for uppercase-only data, "Break," "ESC," and "LF" sensing; one-line buffer ..... \$389

**FLOPPY DISK KIT**

Double-density, IBM 3740-type, hard-sector disk, 300k bytes, controller for RS-232 ASCII interface; has power supply, enclosure, built-in DOS. Transfers at 19,200 baud ..... \$795

**SMOKE SIGNAL BROADCASTING**

**BASIC FLOPPY DISK SYSTEM\*\***

Mini-Floppy system with disk controller plug-compatible with SWTP 6800; cabinet, power supply, and controller handle up to three Shugart Mini-Floppy drives. May be purchased complete, or additional drives can be added later. Includes DOS software in PROM. Stores 80k bytes per disc.

BFD-68. With one drive ..... \$795  
 BFD-68-2. Dual drive ..... \$1169  
 BFD-68-3. Triple drive ..... \$1539  
 Additional drive for 68 or 68-2 ..... \$390

**SOROC TECHNOLOGY**

**IQ-120 TERMINAL**

Displays 12 lines (24 optional), 80 char/line, on built-in 12-in CRT. Includes keyboard with cursor control, numeric keypad, tab, auto-repeat. ASCII 64-character uppercase set (upper-/lowercase 95-character set optional). RS-232 interfaces to computer and extension port (optional) for printer, etc. Has protect mode; displays protected data in reduced intensity. Can erase to end of line, end of field, end of memory, all unprotected data, or complete screen. Switch-selectable baud rates, 75-19,200. Kit/wired ..... \$995/\$1495

**SOUTHWEST TECH. PRODUCTS**

**CT-64 TERMINAL**

CRT terminal, 16 lines of 32 or 64 characters per line; scrolling or page mode operation; upper- and lowercase characters, with switchable lowercase defeat; reversed character printing; control character printing, with defeat switch; cursor control; complete control character decoding. Usable with any eight-bit ASCII computer. With power supply, keyboard, serial interface, beeper, chassis, and cover. Kit ..... \$325  
 CT-VM. Video monitor for above, in matching case. Requires CT-64's power supply. Wired ..... \$175

**AC-30 AUDIO CASSETTE INTERFACE**

Interfaces between computer and terminal (requires accessible, 16x clock and 300 baud rate, RS-232 serial). Provides independent control for two recorders, including automatic start/stop; either cassette may record while the other plays back data. LED indicators display record/read status and data flow. Local/remote switch permits using recorder with terminal alone. Kansas-City standard. Kit ..... \$80

**GT-6144 GRAPHICS TERMINAL**

Cell array is 64 wide by 96 high; each cell addressable by computer; programming allows fixed or moving images. Data can be loaded in less than 2 μsec. Image reversal for white on black or reverse; standard 525-line format; 6144-bit static RAM. Operates with any computer whose parallel interface outputs an eight-bit word and data-ready strobe; this includes any 8080 or 6800 machine. Does not include chassis or video monitor. Programming allows display of graphics, CT-1024 alphanumerics, or combination of both. Kit ..... \$90  
 CT-P Power supply. Kit ..... \$16  
 MP-L.\*\* Interface for SWTP 6800 computer. .... \$35  
 Joystick potentiometer digitizer ..... \$40  
 Slide-potentiometer digitizer ..... \$36

**PR-40 ALPHANUMERIC PRINTER**

Alphanumeric printer with 64 uppercase characters, 40 characters per line, 75 lines per minute. Uses standard 3 7/8-in adding-machine paper. Has internal 40-character line-buffer memory; printing takes place at carriage return or when line-buffer memory is filled; 5 x 7 dot-matrix impact printing. Accepts data up to one character per microsecond or slower; seven parallel data lines are TTL-compatible and

enabled by data-ready signal. Used with any computer having eight-bit parallel interface, including



8080 and 6800 machines. Internal power supply. Size 8 3/4"H x 10 1/2"D x 9 5/8"W Kit ..... \$250  
 PR-4L. Extra ribbon ..... \$5  
 MP-L.\*\* Interface for SWTP 6800 computer ..... \$35

**SYLVANHILLS LAB**

**X-Y PLOTTER**

Plotter and interface kit (mechanics assembled), for interface to any eight-bit TTL parallel port. Pen holder accepts any writing instrument or stylus 7-11 mm diameter; encoded for 0.01-in/pulse, but 0.005-in optional. Pen travel speed 2.5-in/sec max. with 24-V supply, 4.25-in/sec with 36 V. Includes control of pen lift, X and Y motion, start and stop. Drawing surface and power supply not included.

DFT-1. Plotter kit, 11" x 17" drawing area ..... \$750  
 DFT-1M. Mechanical system only ..... \$625  
 DFT-2/ 2M. 17" x 22" ..... \$895/\$770  
 DFT-3/ 3M. 22" x 34" ..... \$1200/\$1025  
 PPS-24. Power supply, 24 V, 1.5 A, regulated .... \$25

**SYNETIC DESIGNS**

**FDS-2 FLOPPY DISK\***

Dual-disk system (256k per disk) with IBM-compatible format, Text Editor, assembler, and Executive Handler for I/O and vector. Controller can handle up to two additional drives. Wired ..... \$2600

**U.S. ROBOTICS**

**M-5 AUTO-ANSWER MODEM**

Allows connection of microcomputer to telephone line; answers incoming calls, allows terminal-to-computer or computer-to-computer data transfer, RS-232 and 20-mA serial interfaces, standard telephone jack. Maintenance contracts available. Operates in originate and answer modes. .... \$105

**VIDEO TERMINAL TECHNOLOGY**

**VT-4800 TERMINAL**

CRT terminal displaying 48 lines x 80 characters, upper-/lowercase, with complete cursor control. Has 4k bytes internal RAM, expandable to 16k; display scrolls up and down through up to 16k characters before any data is lost. Has selective clearing controls, selective video inversion, page increment and decrement. Interfaces to RS-232 serial, TTL serial or parallel I/O. Selectable, 110-9600 baud.

VT-4800-MICRO. Single board, with parts. Kit/wired ... \$395/\$495

VT-4800-MINI. Includes board, parts, power supply, keyboard, and cabinet. Kit/wired ..... \$595/\$795

VT-4800-MAXI. As above, but includes CRT ..... \$795/\$995

**WINTEK**

**B-R-B VIDEO TERMINAL**

Keyboard terminal, available with or without TV monitor. 53-key keyboard, outputs all Teletype characters, 64-character ASCII lowercase set. Lowercase characters received are automatically displayed as uppercase. 16 rows x 80 characters, non-blinking solid cursor, 110-9600 baud; serial interface, RS-232 standard, 20 mA optional. Less monitor ..... \$695

With 9-in. TV monitor ..... \$875

With 12-in. monitor ..... \$995

OEM board (less keyboard and case) ..... \$429  
 Same, less power supply ..... \$395  
 20-mA Current Loop Option ..... \$39

**COMPUTER MODULE BOARDS**

Boards listed below are adaptable for use with more than one company's microcomputer products. Boards intended for use with only one company's computers are listed with that company's products in the Computer section. Items marked with a single asterisk (\*) are for use with the Altair bus; items marked with double asterisks (\*\*) for use with the SWTP 6800 bus.

**ADVANCED MICROCOMPUTER**

**LOGOS I\***

8k static memory (500 nsec). Kit/wired. \$248/\$298

LOGOS I-Z.\* 8k, 250 nsec. Kit ..... \$295

LOGOS I-X.\* Same, less RAMs. Kit ..... \$130

LOGOS 16\* 16k static memory board ..... \$559

LOGOS 32\* 32k static memory Kit ..... \$1195

\$100 UPB.\* Prototyping board ..... \$40

\$100 EXT.\* Extender board ..... \$40

\$100 MB.\* Eight-slot expandable motherboard, with connectors ..... \$90

LOGOS PSIO.\* Parallel/serial I/O board (plug-compatible with Processor Tech. 3P+S) ..... \$145

**EXORCISER-COMPATIBLE**

Pin- and outline-compatible with Motorola EXORCISER, Micromodules, and MEK6800D1 and D2 evaluation kits.

9601. 16-slot motherboard. Wired ..... \$175

9602. Card cage ..... \$75

9610. Utility prototyping board ..... \$36

9615. 4k EPROM module. Kit/wired ..... \$275/\$350

9620. 16-port parallel I/O ..... \$375

9626. 8k RAM. Kit/wired ..... \$275/\$350

9650. Eight-port, duplex serial I/O ..... \$395

**AI CYBERNETIC SYSTEMS**

**Model 1000 SPEECH SYNTHESIZER\***

Forms words and sentences of standard American English from phonemes requested by ASCII characters. Speech rate and vocal pitch adjustable. Requires less than 50 bytes of assembly or five lines of BASIC for programming, data rate typically 25 bytes/sec. Requires less than 2.3 W maximum. Outputs to any amplifier or recorder. .... \$325

**BYTE**

**PROM-BOOT\***

8k PROM card, auto restart from any location in memory, uses 2704/2708 PROMs. Kit ..... \$120

4k PROM.\* Uses 1702A PROMs, conserves power by supplying only the memory chip being accessed. Kit ..... \$100

**CP\***

Control panel with 48 LED binary indicators for address, data, status, I/O and state; control switches include single-step and hardware breakpoint. Kit ..... \$190

**LIF.\***

Line-printer interface, for Okidata parallel printer with full ASCII character and control capability. Kit ..

..... \$200

EXT.\* Extender board ..... \$25

**CAÑADA**

**CL2400 REAL-TIME CLOCK\***

Keeps time in 24-hour format (hr/min/sec); direct output to processor; time automatically updated without using processor time; generates periodic interrupts at programmable rates. Can be used as clock, event/software timer, computer use log, real-time control system. Usable with assembly language or BASIC. Requires 300 mA +8 V, 50 mA +16 V. Kit/wired ..... \$98/\$135

**POWER CONTROL SYSTEM\***

Interface board for power control of external devices, double isolated for safety. Low-voltage on-board switching controls external power switching unit. Controllable by BASIC or assembly statements. Consists of:

PC3216.\* Control logic interface board. 16 independently addressable control channels accessed through a single, user-selectable peripheral address. Requires +8 V 270 mA, +16 V 170-250 mA. Kit/wired ..... \$189/\$240

**PC3202.** Power control unit. Single-outlet remote power control unit, switches 120-V-a.c. loads up to 400 W; compatible with PC3216 control board. Kit/wired ..... \$40/\$52

### CGRS MICROTECH

#### 6502 MPU\*

6502 microprocessor board for Altair bus, with power-up restart.

**Level I.** Includes 256 bytes RAM. Kit/wired ..... \$100/\$130  
**Level II.** With 2k RAM, 4k PROM (2708). Kit/wired ..... \$130/\$180  
**Prototype board\*** ..... \$55/\$65

#### FRONT PANEL\*

Address, data, reset, memory protect and single-step switches, data and address displays. With motherboard for Altair-bus MPUs (also available without motherboard for use with Motorola EXORCisor boards).

**Level I.** Binary displays. Kit/wired ..... \$90/\$100  
**Level II.** Hex displays. Kit/wired ..... \$120/\$180

### COMPUTALKER

#### CT-1 SPEECH SYNTHESIZER\*

Voice generator board producing English speech from acoustic-phonetic parameters transmitted on

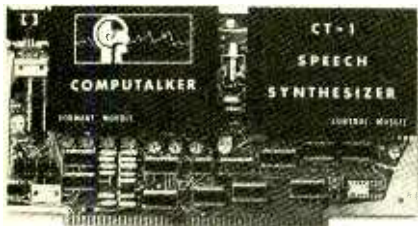

the computer data bus; requires 900 bytes per second of speech. With 8080 driver software, Direct Control Synthesis software, address select switch. Requires +8 V 170 mA, ±16 V 85 mA. Wired . \$395  
**CSR1.** Synthesis-by-rule software for 8080 ..... \$35

### CRC ENGINEERING

#### XPRES DEVICE CONTROL SYSTEM

Complete system interface package allowing control of up to 128 separate devices through one eight-bit port and one strobed enable line. System is modular and expandable in size. System consists of motherboard and interface boards, detailed below. Serial interface to computer optional; high-level language commands possible with serial interface.

**IMB-01 System Motherboard.** Holds five interface boards, one connector board with buffers and status LEDs. Additional motherboards may be daisy-chained to connector board. Kit/wired ..... \$28/\$38  
**IFB-02 Power Relay Board.** Controls four a.c. or d.c. circuits (up to 300 W each), 250 V max. Kit/wired ..... \$58/\$68

**IFB-03 Prototyping Board** ..... \$15

**IFB-04 Reed Relay Board.** Controls low-level signals; can also dial phones. Uses four reed relays. Kit/wired ..... \$36/\$46

**IFB-05 Remote Driver Board.** Controller for four remote interface boards; connects to remote boards through 5-V circuit. Kit/wired ..... \$29/\$37

**IRB-01 Remote Interface.** Remote switching board; switches 115-V a.c., 300 W, with 5-V control signal from IFB-05. Kit/wired ..... \$17/\$25

**ISB-01 Serial Interface.** Allows control of XPRES system through serial ASCII port (20 mA, RS-232, or TTL). Kit/wired ..... \$48/\$58

**ICB-01.** Cabinet for XPRES system ..... \$38

### CROMEMCO

#### CGI TV DAZZLER\*

Graphics interface; 128 × 128, 64 × 64, or 32 × 32 element resolution, software selectable; output in color (eight colors available) or black and white (16 gray-scale intensities). Alphanumeric output also available. Requires RF converter or direct video in-

put. Uses two bus slots, draws 1.4 A @ +8 V, 50 mA @ -18 V. Kit/wired ..... \$215/\$350  
**Programs.** Punched tape with documentation (11 available), each ..... \$15

#### MEMORIES

High-speed, 4-MHz RAM cards for use with high-speed Z-80 computers. Switch-selected bank addressing allows organization into 512k memory (eight banks of 64k each), banks selected under software control (also allows time-sharing with minimum software overhead). Addresses switch-selectable.

**4KZ.\*** 4k static. Kit/wired ..... \$195/\$295

**16KZ.\*** 16k Kit/wired ..... \$495/\$795

**Bytesaver.\*** 8k PROM memory with built-in programmer for 2708 PROMs. Kit/wired ..... \$145/\$245  
**16k PROM Card.\*** Holds up to sixteen, 2708 PROMs. Has bank-select feature for large memory systems (see "Memories" above), and address select. "Address anticipation" feature eliminates wait states on sequential addresses at 4 MHz.  
**16KPR.** Kit/wired ..... \$145/\$245

#### D+7A ANALOG INTERFACE.\*

I/O board with seven channels of eight-bit analog-to-digital conversion for input, seven channels D/A for output, plus one eight-bit parallel digital I/O port. For process control, digital filtering, games, oscilloscope graphics, speech and music uses. Analog signal range, -2.56 to +2.54 V. Takes 0.4 A @ +8 V, 30 mA @ +18 V, 60 mA @ -18 V. Kit/wired ..... \$145/\$245

#### TRT TU-ART DIGITAL INTERFACE.\*

Digital I/O board with two serial, two eight-bit parallel I/O ports, plus 10 independent, programmable interval timers. Has vectored, priority interrupts. Baud rates software-selectable, 110-76,800 baud. Requires 1 A @ +8 V, 80 mA @ +18 V, 40 mA @ -18 V. Kit/wired ..... \$195/\$295  
**TRT-CBL.** Cable for coupling TU-ART ports to EIA D-25 inputs (up to four required) ..... \$14

#### 4-MHz Z-80 CPU CARD\*

Extra-high-speed Z-80 microprocessor card, using Z-80 specially selected for 4-MHz clock-rate operation. Clock switchable, 2 or 4 MHz. Automatically jumps to any desired 4k memory boundary when turned on; no front panel required. Monitor program supplied in paper tape, available in ROM for \$50 more. Kit/wired ..... \$295/\$395

### DAJEN

#### UCRI\*

Universal cassette recorder interface. Switch-

selectable baud rates from 520 to 41,000 baud (maximum usable typically 5000 baud on cassette, 12,000 baud on 7½ ips tape); switch-selectable Tarbell, Kansas-City or other format. Independent switch selection of transmit and receive data inversion for use with different recorders. Level indicator light. Relay option for independent control of two recorders; independent latched input port for keyboard or other use. Kit/wired ..... \$135/\$175  
**Relay option** ..... \$16

#### CRI-B\*

Cassette recorder interface. Switch-selectable baud rate (800-6000 baud) and address, independently switchable transmit and receive data inversion; SYNC and level indicator lights; inputs for line and speaker-level signals; outputs microphone and line-level signals. Kit/wired ..... \$120/\$165

### ELECTRONIC CONTROL TECH.

#### ECT-100\*

20-slot card cage and motherboard, for standard 19-in. rack mounting. Kit/wired ..... \$200/\$300

**Without connectors and guides** ..... \$100

**8KM.\*** 8k static memory. Kit/wired ..... \$295/\$350

**16k RAM.\*** 16k memory ..... \$555/\$635

(Also available with 4k, 8k, or 12k on board for future expansion.)

**2k ROM/2k RAM.\*** ROM/RAM board, less ROMs ..... \$120/\$200

**PB-1.\*** Prototyping board ..... \$28

**EXT-100.\*** Extender card ..... \$24

**MB-20.\*** 20-slot motherboard ..... \$60

### EXTENSYS

#### 64k RAM BOARD\*

Has provisions for "bank switching" for expansion beyond 64k using multiple boards and software selection of memory banks. Wired ..... \$1495

**48k version** ..... \$1195

**32k version** ..... \$895

### FORETHOUGHT

#### KIMS1 MOTHERBOARD\*

Altair-bus motherboard for KIM-1 computer; allows use of Altair-bus peripheral boards with KIM-1 6502 system; can also be connected to other 6502 and 6800 systems; can run on same system as KIM-4 motherboard. Power supply regulators on board, power supply extra. With one 100-pin connector. Kit/wired ..... \$125/\$165

**KIMS1-PLUS.** Power supply, 12 A. Kit/wired. \$60/\$75

**Additional 100-pin connectors.** Kit/installed ..... \$5/\$8

## PHOTO ETCH™ PRINTED CIRCUIT KIT

### MAKES PRINTED CIRCUITS THREE WAYS!

**1 FULL SCALE ARTWORK MASTER**

**2 MAGAZINE ART ILLUSTRATION**

**3 DIRECT ETCH DRY TRANSFERS APPLIED TO COPPER CLAD BOARD**

DEVELOPED PHOTO RESIST IMAGE ON COPPER CLAD CIRCUIT BOARD

ETCHED CIRCUIT BOARD

**The revolutionary photographic way that makes PERFECT printed circuits from YOUR ARTWORK or a PRINTED PAGE! No camera. No darkroom. No tracing. No film cutting. Simple and fast.**

KIT CONTAINS 5" x 6" steel printing frame, 4 sheets 5" x 6" photopolymer film, yellow filter, chemicals for 1 pint film developer and 1 pint film fixer, 5" x 6" copper clad board, 3" x 4" copper clad board, spray can of photo etch resist, 1 pint resist developer, 2 sheets 8½" x 11" layout film, 1 roll 1 16" printed circuit tape, 1 roll 1 32" printed circuit tape, 8 sheets dry transfer direct etch PC patterns including pads, transistors, round and flat pack ICs, DIP ICs, edge card connectors, lines, circles, jogs, etc., ¼ lb. anhydrous ferric chloride to make 1 pint etchant, instructions.

**ER-4 COMPLETE PHOTO ETCH SET** ..... postpaid \$26.95  
 (N. J. residents add sales tax)

AT YOUR DISTRIBUTOR OR DIRECT

the DATAK corp. • 65 71st Street • Guttenberg, New Jersey 07093

1978 Edition

CIRCLE NO. 6 ON FREE INFORMATION CARD

113

## FRANKLIN ELECTRIC

**8k RAM**  
8k static RAM board. Kit/wired ..... \$225/\$280  
With IC sockets, add ..... \$15

## GIMIX

**GHOST VIDEO BOARD\*\***  
Displays 16 lines x 32 characters, uppercase (can be wired for 16 x 64, with 10 MHz video monitor). Occupies 1k memory space. Text scrolling and cursor software-generated. Adjustable density and left-hand margin. Assembled ..... \$249

**GHOST 8K EPROM BOARD\*\***  
Uses 2708 EPROMs. Can be addressed to any 8k memory boundary (including E000 to replace MIK-BUG). Wired ..... \$119  
Ghost Extender Board\*\* ..... \$25

## GODBOUT

**4K ECONOROM\***  
Comes with editor, assembler and monitor routines for 8080. Kit ..... \$265  
**8k EconoRAM II.\*** Addressable in separate, 4k blocks. Kit ..... \$164  
**10-slot motherboard\*** ..... \$85  
**18-slot motherboard,\*** with connectors ..... \$118  
**Terminator Board.\*** Adds active terminations to bus to minimize noise, overshoot and other interference. Plugs into one slot ..... \$30

## HEURISTICS

**SpeechLab\***  
Voice input for computers, with microphone and software. Requires 64 bytes of storage per spoken word. Kit/wired ..... \$249/\$299

## HOMESTEAD TECHNOLOGIES

**HTC-88P BREADBOARD MODULE\***  
Altair-bus module board with built-in "breadboard" sockets, for circuit development ..... \$138

**HTC-88PF.** Foil-pattern prototyping board, with same layout as 88P, to facilitate hard-wiring of circuits developed on 88P breadboard ..... \$38

## ICOM

**FLOPPY-DISK INTERFACE\***  
For ICOM Frugal Floppy and FD3711 drives (see Peripherals), Altair-bus computers. Includes DOS software (BASIC \$50 extra). Wired ..... \$300

## ISMAI

**MEMORIES**  
**RAM 4A-4.\*** 4k static RAM memory. Kit/wired ..... \$139/\$279  
**16k RAM Memory.\*** Kit/wired ..... \$449/\$679  
**32k RAM Memory.\*** Kit/wired ..... \$749/\$1099  
**65k RAM Memory.\*** Kit/wired ..... \$2599/\$3899  
**PROM 4-512.\*** 4k EPROM board with 512 bytes of EPROM. Kit/wired ..... \$165/\$247  
**PROM 4-4.\*** Same, with 4k EPROM. Kit/wired ..... \$399/\$579  
**IMM-ROM.\*** Intelligent Memory Manager control board for up to one megabyte of memory. ROM version. Kit/wired ..... \$299/\$399  
**IMM-EPROM.\*** EPROM version. Kit/wired ..... \$499/\$699

## INTERFACES

**MIO.\*** Multiple I/O board (two parallel, one serial, one control port, one Byte/Tarbell cassette interface). Less cables. Kit/wired ..... \$195/\$350  
**PIO 4-1.\*** Parallel I/O with one port, expandable to four ports. Less cables. Kit/wired ..... \$93/\$140  
**PIO 4-4.\*** Parallel I/O with four ports. Less cables. Kit/wired ..... \$156-\$299  
**SIO 2-1.\*** Serial I/O with one port, expandable to two ports. Less cables. Kit/wired ..... \$125/\$235  
**SIO 2-2.\*** Serial I/O with two ports. Less cables. Kit/wired ..... \$156/\$299  
**SI0C.\*** Serial I/O clock piggyback board for SIO 2-1, 2-2.\* Kit/wired ..... \$31/\$59  
**PIO6-6.\*** Programmable six-port parallel I/O. Less cables. Kit/wired ..... \$169/\$279

## OTHER BOARDS

**PIC-8.\*** Priority interrupt/interval clock. Kit/wired ..... \$125/\$238  
**EXT.\*** Extender board. Kit/wired ..... \$39/\$49  
**GP-88.\*** Prototyping board. Kit/wired ..... \$39/\$47  
**Multiprocessing and Shared Memory:** Write for details.

## INTERNATIONAL DATA

**CLOCK MODULE\***  
Real-time clock board; uses 60-Hz a.c. line as time reference (50-Hz optional), with on-board crystal time base (optional) and external battery backup power; does not load CPU except when clock is set or read. Time is set and read via I/O instructions (port addresses selectable); timed interrupts under software control. Draws 400 mA, +8V.  
**88-SPM.** Clock module. Kit ..... \$96  
**88-SPM/50.** 50-Hz version ..... \$96  
**88-ICS.** IC sockets for above ..... \$10  
**88-XTAL.\*** Crystal timebase for 88-SPM ..... \$25  
**88-SPM/A.** Assembled, with sockets and xtal ... \$199

## UNIVERSAL FREQUENCY COUNTER\*

Frequency and interval counter, nine decades, software controlled, making programming and reading possible for process control applications. Measures frequency from d.c. to 500 MHz and higher. Software selection of: interval and timebase; port (one of four), counter/period, interrupt enable for time/period, stop/run counter. Kit/wired ..... \$149/\$199

## 88-MODEM\*

For telephone data communications. Originate mode with auto-dial feature allows your computer to call others; answer mode allows others (or terminals) to call yours. Compatible with Bell 103 data sets at rates from 110-300 baud, including 133.4 Selectric speed; 0-600 baud when communicating with other 88-MODEM modules. Kit/wired ..... \$199/\$249

## MATROX

**VIDEO RAMS**  
Video controller modules addressed as RAM memory, each on-screen character equivalent to a one-byte memory location. Character blinking available.

Controllers available as plastic-packaged modules, or as complete module boards.

**MTX-816.** Video RAM for eight lines, 16 characters, uppercase ASCII (128 bytes) ..... \$179  
**MTX-1632.** 512-byte VRAM, 16 lines x 32 characters, upper-/lowercase ASCII. Drives up to 25 TV monitors ..... \$225  
**MTX-1632SL.** Externally synchronized version, allows output to be mixed with or superimposed on other images ..... \$225  
**MTX-2480.\*** 24 lines x 80 characters, upper- and lowercase, half-intensity, blink, inverse video (lowercase requires long-persistence CRT phosphor) ... \$395  
**MTX-256\*\*2.** Graphics board; 256 x 256, individually addressable dots. Color or grey-scale available. Light pen, cursor plot, point plot, alphanumerics, and ROM screen patterns may be implemented. On PC board, with 44-pin edge connector ..... \$630  
**ALT-2480.\*** Altair-bus-compatible board with MTX-2480; 4k video RAM providing 24 lines x 80 upper-/lowercase ASCII, strappable for two pages of 40 characters per line, allowing use of low-bandwidth monitor ..... \$295  
**ALT-256\*\*2.\*** Altair-bus-compatible board with MTX-256\*\*2 graphics VRAM; two may be combined for grey-scale or color operation ..... \$395  
**Character fonts.** 1632 and 2480 may be supplied with upper-/lowercase ASCII, uppercase ASCII/Greek, General European, and French character fonts at no extra charge. Japanese (Kata-Kana), British, German, math symbols, etc., available for \$150 per order. Custom-designed character fonts available.

## MICRO-BUILDERS INK

**BURROUGHS/FRIDEN TERMINAL INTERFACE\***  
Interface Burroughs/Friden communications terminals to Altair bus. Parallel I/O, but simulates serial port with TBE and RDA flags; replaces TTY with no software changes. Interface is wire-wrapped card with switch-selectable port addressing and lowercase lockout, jumper selection or half or full duplex. Draws about 0.5A from +8-V bus; requires about 1 A @ 24 V additional for terminal mechanics. Wired ... \$150  
**Power Supply.** 24-V, 1-A power supply. Wired .... \$40

## MICROGRAPHICS

**THE DETAILER\***  
Video display for alphanumerics (64 characters, 16 lines, uppercase) and graphics. Has character-selective inverse video, 64 programmable graphics characters. Kit ..... \$249

## MICROLOGIC

**M705 RESTART/CLOCK BOARD\***  
Automatically restarts computer at any desired memory address (no restrictions to 4k or page boundaries) after power failure; if memory has battery back-up, automatically saves contents of registers until power returns. Protects memory against random writes when bus voltage is low. Real-time clock generates interrupts under software control, for clock reference or event timing. Includes DIP socket and switch to replace front-panel sense switches, where necessary. Wired only ..... \$100

## M712 I/O BOARD\*

For interfacing Digital Group/Phi-Deck cassette system to Altair-bus computers (also suitable for general-purpose, bidirectional I/O). Includes data and status/control ports, hardware-generated I/O strobes to simplify software. Kit/wired ..... \$70/\$80

## MICROMATION

**JUMP START\***  
RAM board, 4k, with automatic jump to any preset memory byte on power-up or reset; has switchable WAIT state for systems faster than 2 MHz, protect; both switches on top of board for easy access. Provision for battery backup. Kit/wired ..... \$145/\$190

## UNIVERSAL DISK CONTROLLER\*

For hard- or soft-sectored, standard or mini-floppy, single or double density. On-board memory provides RAM buffers, PROM software storage. Includes RS-232 and 20-mA interface for terminal. Controls up to three drives. Kit/wired ... \$229/\$299

## TYPEAWAY\*

Interfaces IBM I/O Selectrics (Model 731, 735) to

# THE MEAN LITTLE KIT



New compact 24-piece kit of electronic tools for engineers, scientists, technicians, students, executives. Includes 7 sizes screwdrivers, adjustable wrench, 2 pair pliers, wire stripper, knife, 2 alignment tools, stainless rule, hex-key set, scissors, 2 flexible files, burnisher, miniature soldering iron, solder aid, coil of solder and desoldering braid. Highest quality padded zipper case, 6 x 9 x 1-3/4" inside. Satisfaction guaranteed. Send check, company purchase order or charge BankAmericard or MasterCard. We pay the shipping charges.  
**JTK-6 TOOLKIT** ..... \$65.00

## FREE CATALOG

144 pages of hard-to-find precision tools. Also contains 10 pages of useful "Tool Tips" to aid in tool selection. Send for your free copy today!



**JENSEN TOOLS & ALLOYS**  
1330 SOUTH PRIEST DRIVE • TEMPE, AZ 85281

CIRCLE NO 12 ON FREE INFORMATION CARD

Altair-bus computers. Includes solenoid drivers, input ports, PROM software, 70-W power supply, all necessary cables and connectors. Will interface 24-V or 48-V solenoids. Kit/wired. .... \$225/\$275

## MICRONICS

### BETTER BUG TRAP\*

Debugging board with four hardware breakpoint address registers and a 16-bit clock. Can detect addresses, generate time intervals for real-time clock, interval timer, single-step, etc. With 8080A, generates CALL instruction to any memory location when interrupting. Occupies 16 bytes of memory. Functions include master reset, wait on address, interrupt on address, timed interrupt. Compatible with vectored interrupt boards. Wired only. .... \$180

## MIDWEST SCIENTIFIC

### MEMORIES

**RAM-68.\*\*** 8k RAM for SWTP 6800. Has battery back-up provision. Kit, without/with sockets ..... \$249/\$299

**EPR-8.\*\*** 8k EPROM. Holds eight 2708s. Comes with instructions on modifications for use of EPROM board restart vector, MIKBUG start-up routine. Without/with sockets. .... \$95/\$110

**PRR-68.\*\*** 4k PROM/RAM board, holds 15 156-byte pages of 1702A PROM (3840 bytes total), plus one page RAM. Comes with modification instructions for use as restart vector in place of MIKBUG start-up routine. Without/with sockets. .... \$95/\$120

**Monitor.** In 1702A PROMs. Replaces MIKBUG, retains full compatibility with all MIKBUG software, plus additional and user features, including CRT handler for CRT-1 (see Peripherals). Requires PRR-68. .... \$275

**Extender Card.\*\*** For SWTP 6800, 50-pin bus. Kit. .... \$25

## MINITERM ASSOCIATES

### MERLIN VIDEO INTERFACE - I/O\*

Combination alphanumeric/graphics interface with I/O and ROM facilities. Alphanumerics: 40-charac-



ters by 20 lines, uppercase ASCII, plus inverted video control characters; cursors may be inverted, blanked, or normal; under software control, carriage returns may be displayed or may terminate display line; ASCII and graphics may be mixed. Graphics: Normally software-selectable for sparse (80 x 100) or dense (160 x 100) resolution; super-dense option (320 x 200) can replace sparse mode; all eight bits of each byte are mapped — no interbyte or interline spaces; DMA controller allows display to change with every screen refresh, information on screen not blanked while being modified. I/O: Provides parallel input port with power to run most keyboards; one serial port. ROM: two sockets provided for 1k (2708) PROM or ROM or 2k ROM (firmware available), plus 256-byte RAM for Merlin scratchpad and stack. Monitor/Editor: See under MBI and MEI, below. Interface consists of two, back-to-back mounted boards occupying one Altair-bus slot. MERLIN, as above. Kit/wired. .... \$269/\$349

**M320.** Super-dense graphics add-on. .... \$39/\$54

**MCAS/KC-2.** 1500-baud Tarbell cassette interface add-on (requires MEI ROM). Kit/wired. .... \$29/\$43

**MSEK.** Serial I/O expansion kits, expands MERLIN to three parallel inputs, three parallel outputs ..... \$45/\$75

**MC/IO.** Combines MCAS and MSEK on one PC board, designed to be housed in keyboard enclou-

sure. Kit/wired. .... \$67/\$99

**MBI.** Merlin Basic Intelligence, 2k ROM monitor/editor for Merlin, plus 256-byte RAM. Provides turnkey monitor, cursor control, wraparound scrolling, text editing. Easily interfaced to BASIC or other monitors ..... \$40

**MEI.** Merlin Expanded Intelligence, ROM with cassette (MCAS) routines, extended edit and monitor commands, graphic subroutines. .... \$35

### ROM/EROM\*

**8k,** 2708 board (also for up to 2k ROM), with power-on start to any 1k address boundary. Kit/wired. .... \$89/129

### FDI \*

Minifloppy Interface kit for up to three drives, with bootstrap ROM. Kit/wired. .... \$260/\$329

### BKPL\*

Eight-slot, Altair-bus motherboard. .... \$35

**BKPL-E.\*** Same. with edge connectors, wired. . \$109

**VDRK.\*** Card rack and BKPL-E. Designed for card ejectors. .... \$160

## MITS

### MEMORIES

**88-4MCS.\*** 4k static RAM. Kit/wired. .... \$167/\$310

**88-S4K.\*** Synchronous 4k board, relies solely on CPU for timing signals to avoid wait states; Access time 200-300 nsec. Kit/wired. .... \$155/\$255

**88-16MCS.\*** 16k static memory board. .... \$765/\$945

**88-PMS.\*** PROM memory Card, holds up to 2k bytes in 1702/1702A PROM. .... \$85/\$125

### INTERFACES

**88-2SIO.\*** Serial interface board for two I/O ports (one port supplied), each user-selectable for 20 mA or RS-232, 110-9600 baud. Kit/wired. .... \$150/\$185

**SP.** Second serial port for above. .... \$38/\$50

**88-4PIO.\*** Parallel I/O board for up to four I/O ports (one supplied). 16 data lines per port allow each to

be used for one I/O, two input (e.g., reader) or two output (e.g., printer) devices. Kit/wired. . \$105/\$130

**PP.** Additional parallel ports for above. .... \$43/\$55

**88-ACR.\*** Audio cassette interface, compatible with Altair software, 300 baud. Kit/wired. .... \$124/\$148

**88-VI/RTC.\*** Vector interrupt/real-time clock. Accepts interrupts from up to eight devices, in priority order, vectoring each to appropriate instruction address; also provides time-controlled interrupts based on system clock or a.c. power-line frequency. Kit/wired. .... \$138/\$185

**88-AD/DA.\*** Eight-bit analog-digital/digital-analog converter; eight multiplexed input channels, two output D/A converters. Wired. .... \$395

**88-ADC.\*** 12-bit analog-to-digital input interface with eight-channel multiplexed input for unipolar inputs (0-5 V, 0-10 V); direct input to buffer available for

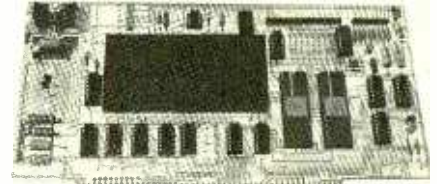

bipolar ( $\pm 5$  V,  $\pm 10$  V) input. Also provides vector interrupt facility for reading at fixed, real-time intervals. Wired. .... \$524

**88-MUX.\*** 24-channel multiplexer; replaces eight-channel multiplexer of 88-ADC board; MUX and ADC together occupy one slot. Filtering and scale factoring independently adjustable for each channel; or available with differential inputs for small-signal applications. Up to four MUX cards may be used with one ADC on special option, permitting up to 96 input channels. Wired ..... \$319

**88-PCI.\*** Process control interface. Eight relay outputs for device control, eight opto-isolator inputs, plus handshake logic. Status of all relays set at

# This is easy- anyone can solder- WITH KESTER SOLDER

KESTER  
SOLDER



## Handymen! Hobbyists! DO-IT-YOURSELFERS!

Let Kester Solder aid you in your home repairs or hobbies. For that household item that needs repairing — a radio, TV, model train, jewelry, appliances, minor electrical repairs, plumbing, etc. — Save money — repair it yourself. Soldering with Kester is a simple, inexpensive way to permanently join two metals

When you Solder go "First Class" — use Kester Solder

For valuable soldering information send self-addressed stamped envelope to Kester for a FREE Copy of "Soldering Simplified"



KESTER SOLDER

Litton 4201 WRIGHTWOOD AVENUE/CHICAGO, ILLINOIS 60639

once by a single eight-bit output byte. Wired ... \$235  
**PPCB.\*** Prototyping board ..... \$45  
**WWB.\*** Wire-wrapping prototyping board ..... \$20  
**EXC.\*** Extender board kit ..... \$46

## MORROW'S MICRO-STUFF

### I/O-CASSETTE INTERFACE\*

Single-board I/O system with serial port (RS-232 or 20 mA), parallel port, interface for three audio cassette machines. On-board, 512-byte, PROM contains all I/O routines including cassette formatting, deformatting and error-checking, and bootstrap loader. Unused I/O can be used for device control. Requires 1k memory locations; specify starting address when ordering. Kit/wired ..... \$120/\$165

## MOTOROLA

The following boards are all for Motorola Micromodule, EXORciser, MEK60002, or other compatible systems.

### MICROMODULE SERIES

**M68MM03.** 32/32 I/O module. Four parallel input and four output ports ..... \$375  
**M68MM04.** 8k ROM/PROM. Convertible to 61k. .... \$210  
**M68MM04-1.** 16k ROM/PROM ..... \$230  
**M68MM06.** 2k static RAM ..... \$280  
**M68MM05A.** Eight-channel, 12-bit, differential-input A/D module ..... \$725  
**M68MM05B.** 16-channel, 12-bit single-ended input A/D module ..... \$725  
**M68MM05C.** Quad 12-bit D/A module ..... \$725

### EXORCISER SERIES.

**MEX6812-1.** 2k memory ..... \$350  
**MEX5815.** 8k dynamic memory ..... \$695  
**MEX6816-1.** 16k dynamic RAM ..... \$1195  
**MEX68RR.** PROM/RAM module (16k ROM, 512-byte RAM) ..... \$395  
**MEX6820.** I/O module ..... \$375  
**MEX6850.** ACIA serial I/O ..... \$375  
**MEX68WW.** Wire-wrapped module ..... \$59  
**MEX68XT.** Extender module ..... \$79  
**MEX68PP1.** PROM/programmer module ..... \$595

## MOUNTAIN HARDWARE

### PROROM\*

8k ROM/RAM/programmer board. Holds 7.5k EPROM (6834) plus 1/2k RAM for stack or scratchpad. On-board PROM programmer requires no special software, and can program from 1 to 7.5k bytes at once. Includes RAM, plus one PROM with 8080 monitor ..... \$164

## M.R.S.

### AM6800 MPU\*

6800 microprocessor board for Altair-bus computers. Allows conversion to 6800 or alternate and simultaneous use of both 6800 and 8080 (or Z-80) processors. Kit/wired ..... \$150/\$130  
**AM6800k.** Kit, less 6800 MPU chip ..... \$98  
**AM6800PC.** PC board and documentation only ... \$40

## MULLEN

### EXTENDER BOARD\*

Raises Altair-bus boards above others in chassis for easier in-circuit testing. Includes TTL logic probe indicating low- and high-level logic and pulses, jumper links in power lines for current measurement and fusing of board under test. Kit only ..... \$35

### OPTO-ISOLATOR/RELAY CONTROL BOARD\*

Interface board for device control. Has eight reed relays (rated 10 VA, 20-200 V) controllable by eight-bit computer command, eight opto-isolators for feedback handshake. I/O port address switch-selectable. Kit only ..... \$117

## NATIONAL MULTIPLEX

### 2510(R) "BOOTSTRAP ELIMINATOR"

Combination ROM monitor, cassette and serial I/O board. Connects terminal (20 mA, RS-232, or TTL), one or two digital or audio cassette units; all necessary routines in high-speed, fuse-link ROMs, including tape start/stop for audio cassette, plus rewind and fast-forward for digital tape units. Includes word-processing, tape-punching and reading routines. Can be used for phase-encoded, Kansas

City, MITS, and IMSAI tapes. Kit/wired . \$160/\$190

## PARASITIC

### CLOCK FIX KIT

Temperature-compensated, non-overlapping clock for Altair 8800 and 8800a ..... \$15

### CONSTANT-VOLTAGE KIT

Constant-voltage transformer, high-current rectifiers and improved filtering to maintain Altair performance with line voltage swings up to 90-140 V. \$90

### 26A POWER SUPPLY KIT

General-purpose power supply with constant-voltage transformer; +9 V @ 20 A, ±16 V @ 6 A total. Complete with key switch, detachable power cord, fuse holder. Fully insulated, plug-together assembly ..... \$200

## PERCOM

### CASSETTE/TERMINAL INTERFACE

Dual-function interface board, available in models for Altair\* and SWTP 6800\*\* busses. Cassette interface is Kansas-City standard, with independent record and playback circuits, optional relay kit for programmed control of two recorder/players. Also includes RS-232 terminal interface.

**CI-812.\*** For Altair bus. Tape data transfer at 30, 60, 120, or 240 bytes/sec; RS-232 @ 300-9600 baud. Kit/wired ..... \$90/\$120

**Test cassette** for above ..... \$5

**CI-30+.\*** For SWTP 6800 bus, or any computer with 19.2-kHz clock, UART, USART, or ACIA interface. Tape at 30, 60, or 120 bytes/sec; RS-232 at 300, 600, or 1200 baud. Plays unmodified SWTP cassette software. Kit/wired ..... \$70/\$90

**Remote Control Relay Kit** ..... \$11

## PICKLES & TROUT

### TTVM-04 VIDEO MONITOR ADAPTER

Kit adapts Hitachi and other TV sets using Hitachi "SX" chassis for use as 12-in video monitors. Switch allows normal TV use. Up to 90 char/line ..... \$20

### BDPIO I/O BOARD\*

Eight-port parallel I/O including two latched and six bus ports, with uncommitted lines for power or user-selected signals. IEEE-488 (HP-IB) bus adapter and junction/address decode/buffer box available. Wired ..... \$165

## POLYMORPHIC

### VIDEO TERMINAL INTERFACE\*

96-character ASCII (including lowercase) and 32 special characters, plus graphics. Uses 7 × 9 character font, 16 lines by 64 characters; graphic resolution 48 vertical by 64 horizontal (128 optional). Requires 1.25 A @ +8 V, 30 mA +16-20 V, 20 mA -16-20 V. For 32/64 character, kit ..... \$210/\$280

### 8K MEMORY\*

With provision for battery backup. Kit/wired ..... \$300/\$385

### I/O IDEABOARD\*

Prototyping board for I/O in blocks of four addresses. Requires +8-10 V @ 370 mA, excluding user-added components. Kit ..... \$55

### CPU\*

8080 processor with 1/2k RAM, vectored interrupt, real-time clock, space for up to 3k ROM (1k ROM monitor available). Accepts inexpensive printer (serial) and cassette interfaces. Kit ..... \$215

**Printer Interface.** Fits above MPU only. RS-232 or 20 mA. Kit/wired ..... \$65/\$80

**Cassette Interface.** For above MPU only. Kansas City (300 or 600 baud) and PolyPhase (1200, 2400) standards. Kit/wired ..... \$65/\$85

## PROCESSOR TECHNOLOGY

### GPM\*

General purpose memory. Combines 1k RAM, 2k ROM or PROM, space for 8k additional EPROM (2708). (Required for use of ALS-8, SIM-1, and TXT-2 ROMs). Kit/wired ..... \$129/\$169

**GPM-Sol.** As above, but without RAM and ROM. Kit/wired ..... \$89/\$119

### ALS-8 ROM

Resident assembly language operating system. Stores, assembles, restores, and links assembly-language programs, with line numbers. ROM set (requires GPM) ..... \$159  
**ALS-8 on CUTS** cassette paper tape ..... \$35/\$45

### SIM-1 AND TXT-2 ROM

Interpretive simulator allows pre-testing of 8080 programs without crashing system; TXT-2 adds automatic line-numbering to ALS-8, also allows insertion, deletion, and rearrangement of single characters, lines, or portions of lines. ALS-8 and GPM required. ROM ..... \$60

### 4KRA\*

4k static RAM. Kit/wired ..... \$159/\$195

### 8KRA\*

8k static RAM. Kit/wired ..... \$295/\$375

### 16KRA\*

16k dynamic RAM. wired ..... \$529

### 2KRO\*

2k EPROM (1702A) module. Kit/wired ..... \$65/\$89

### 3P-S I/O MODULE\*

Two eight-bit parallel I/O ports, plus one control port, one serial I/O port (35-9600 baud). Kit/wired ..... \$149/\$199

### VDM-1\*

Video display module. Displays 16 64-character lines, upper- and lowercase. Multiple, programmable cursors, reverse characters, blinking. With software on paper tape for interfacing with machine-language or BASIC programs. Kit/wired .... \$199/\$295

### CUTS CASSETTE INTERFACE\*

Operates 300 baud (Kansas-City standard) and 1200 baud (CUTS). Kit/wired ..... \$87/\$119

### SUBSYSTEM B\*

Combines all basics necessary for practical use of Altair-bus computers: RAM and PROM memory, parallel, serial, cassette and video display interfaces, and software (including CUTS 1200-baud cassette bootstrap). Includes 2k ROM monitor, space for 8k bytes additional ROM.

**B70.** With 5k RAM. Kit/wired ..... \$594/\$829

**B110.** With 9k RAM. Kit/wired ..... \$730/\$998

**B190.** With 17k RAM. Kit/wired ..... \$964/\$1163

## RIVERSIDE ELECTRONIC

### MVM-1024 VIDEO MODULE

Parallel access video display for 8080, 6800, and other MPUs. Displays 16 rows × 64 characters, full 128-character upper/lowercase ASCII, with inverted characters; true, blinking cursor, independent of character reversal. Organized as three, bidirectional I/O ports, so requires no address lines, no use of MPU registers to form memory pointer. Cursor display is blinking over- and under-line. Wired only ..... \$225

## RMQ SYSTEMS

### PS-1 POWER-START\*

Auto-load board; restarts computer at address of ROM monitor or bootstrap loader upon power-up or re-set. Can be switched out when desired; has on-board switches substituting for front-panel sense switches for terminal options, etc. Available with on-board ROM, or without for use in systems with ROM. Can be located anywhere in memory address space. With ROM. Kit/wired ..... \$195/\$295  
**PS-1.** Without ROM. Kit/wired ..... \$165/\$265

## SEALS

### 8KSC\*

8k static memory, with address-select switch. Kit/wired ..... \$269/\$369

**8KSCZ.\*** Faster version for Z-80. Kit/wired ..... \$295/\$395

### 4KROM\*

4k read-only memory, takes 1702A or 5203 EPROMs Address switch. Kit/wired ..... \$119/\$179

### 8BUC\*

Battery backup card for 8k memory. Holds and automatically recharges Ni-Cad batteries to protect memories when power is off. Less batteries. Kit/wired ..... \$55/\$68

## SMOKE SIGNAL

### M-16 16K MEMORY BOARD\*\*

16k static RAM board for SWTP 6800 bus. Allows expansion to 32k without modifying computer, expansion to 48k with simple modification to MPU board. Requires 8 V, 1.8 A from computer. Wired ..... \$595

### P-38 PROM BOARDS\*\*

Holds up to 8k, type 2708 EPROMs, or pin-compatible ROM or PROM. Switch-selectable address; can accommodate MIKBUG or MINIBUG II ROMs, with interrupt vectors switchable between MIKBUG and user PROM. Requires modification to computer's 12-V power supply, or PS-1 power supply below. Wired ..... \$179

**P-38-I.** Same, with additional interface for Oliver Tape reader and Smoke Signal Broadcasting EPROM programmer; includes tape-loader software ..... \$229

**P-38-FF.** Same as P-38-I, with addition of plug-in interface for ICOM Frugal Floppy (see Peripherals); includes one 2708 with ICOM bootstrap software ..... \$299

**PS-1.** Power supply, ±16 V @ 2 A; will operate up to five P-38s ..... \$25

**PROM Programmer.** For use with P-38I or -FF ..... \$125

## SOLID STATE MUSIC

### MEMORIES

**MB4.\*** 4k/8k memory board, can be converted from 4k to 8k by "piggy-backing" memory IC's and changing switch and jumper settings.

4k. Kit/wired ..... \$130/\$180

8k. Kit/wired ..... \$210/\$300

**MB6A.\*** 8k memory board. Switch-selected memory protect, address assignments, and wait cycles. Provision for battery back-up. Kit/wired ..... \$265/\$325

**MB7.\*** 16k static memory. Switch at top of board allows address selection to any 4k boundary, without removing board, memory protect separated into 4k blocks. Kit/wired ..... \$525/\$625

### PROM MEMORIES

**MB-3 2K/4K.\*** Switch-selectable address and wait cycles. Kit only. Less EPROMs/with eight (1702) EPROMs (2k)/with 4k ..... \$65/\$105/\$145

**MB8, 8k/16k.\*** Similar to MB-3, but uses 2708 EPROMs. Kit only, less EPROMs ..... \$85

### INTERFACES

**IO-2.\*** Input/output PROM and universal Board. One parallel I/O port committed, with provision for three additional ports, including one serial; provisions to facilitate wiring for EPROMs, etc. Board/kit/wired ..... \$30/\$55/\$80

## TARBELL

### 1001 CASSETTE INTERFACE\*

Saves and reads data on audio cassette machines. Data transfer rates up to 540 bytes per second with high-quality cassette recorder, 187 bytes/sec suggested for medium-quality recorders (both Tarbell format); modifiable for Kansas-City format @ 27 bytes/sec. With Triple-I Phi-Deck, 1000 bytes/second @ 10 in/sec. Extra status and control lines available for use with computer-controlled drives such as Phi-Deck, or multiple tape recorders with Ro-Che controller (see Peripherals). Includes software, room for user-developed circuits. Kit/wired ..... \$120/\$175

## TECHNICAL DESIGN LABS

### ZPU CARD\*

Z-80 CPU card. Dual on-board clocks, one crystal-controlled @ 2 MHz for system cards requiring that speed, one variable to fine-tune system for maximum performance. Requires +8 V, 600 mA. Runs Z-80 and most 8080 interrupts. Kit/wired ..... \$269/\$345

### TDL-SMB SYSTEM MONITOR BOARD\*

Combines all basic support needed for Z-80 system: 2k ROM ZAPPLE monitor, 2k RAM, three serial I/O ports (two RS-232/20 mA; one 1200-baud

TDL audio cassette interface), one eight-bit parallel I/O port, power-on restart. Kit/wired ..... \$295/\$395

## TED

### REAL TIME CLOCK

Time-of-day clock, connects to TTL parallel I/O port of any computer system; requires +5, +12 V. Push-button time setting; can run off separate power supply or battery (crystal-controlled). Wired only ..... \$40

## VAMP

### TRVM-1 VIDEO ADAPTER

Television modification kit for direct video input. (Includes transfer switch for normal TV reception.) Bypasses tuner and IF sections. 10-MHz bandwidth allows up to 64 characters per line. For transformer-isolated sets only ..... \$20

**HCVM-1.** Same, for sets without power transformers ..... \$24

## VECTOR

### 8800V MICROPROCESSOR PLUGBOARD\*

Epoxy glass prototyping board with ground and power busses, provision for two heat-sinks (one supplied); will hold two, 40-pin, eight 24-pin, and 36 14- or 16-pin DIPs, or other combinations. .... \$20

## VECTOR GRAPHIC

### PROM/RAM BOARD\*

1k RAM for stack storage, no need to relocate when adding memory. Room for 2k PROMs (1702A) for monitor, loader, and utility routines. Jump-on-reset to any desired memory address. Without PROMs, Kit/wired ..... \$89/\$129

## XYBEK

### PFLAMMER\*

PROM programmer for 1702A EPROMs, with 2k on-board memory (256 bytes RAM, 1792 bytes EPROM). Kit ..... \$189

**Extension cord** with zero-insertion-force socket for programming PROMs outside the computer ..... \$15

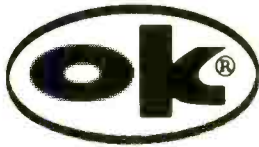

## WIRE WRAPPING TOOL

For AWG 30, .025" (0.63mm) sq. post, "MODIFIED" wrap, positive indexing, anti-overwrapping device

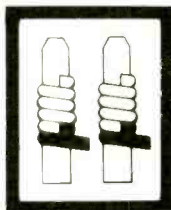

## OK MACHINE & TOOL CORPORATION

3455 Conner St. Bronx, N.Y. 10475 / (212) 994-6600 / Telex 125091

# NEW

HOBBY-WRAP  
Model BW-630



Battery  
wire  
wrapping  
tool

ONLY **\$34<sup>95</sup>** (batteries not included)  
COMPLETE WITH BIT  
AND SLEEVE

Get updated . . . keep updated with

# BYTE

the leading magazine in the  
personal computer field



*The personal  
computer  
age is here.*

*Home computers  
. . . practical,  
affordable.*

Join Byte's 100,000 subscribers and catch up on the latest developments in the fast-growing field of microprocessors. Read BYTE, The Small Systems Journal that tells you everything you want to know about personal computers, including how to construct and program your own computer (over 30,000 BYTE readers have already built, or bought, their own systems and half of these have 8K bytes or more). You'll find our tutorials on hardware and software invaluable reading, also our reports on home applications and evaluative reviews based on experiences with home computer products.

Large scale integration has slashed prices of central processors and other computer components. This has encouraged the development of new, low-cost peripherals resulting in more hardware and software — more applications than you could imagine, more opportunities for you. BYTE brings it all to you. Every issue is packed with stimulating and timely articles by professionals, computer scientists and serious amateurs. BYTE editorials explore the fun of using and applying computers toward personally interesting problems such as electronic music, video games and control of systems for alarms to private information systems.

## Subscribe now to BYTE . . . The Small Systems Journal

Read your first copy of BYTE, if it's everything you expected, honor our invoice. If it isn't, just write "CANCEL" across the invoice and mail it back. You won't be billed and the first issue is yours.

Allow 6 to 8 weeks for Processing.

©  
Byte Publications, Inc. 1977

BYTE Subscriptions Dept. P.O. Box 361 Arlington, Mass. 02174 U.S.A.

38Z Please enter my subscription for:

- One year U.S. - \$12       Two years U.S. - \$22       Three years U.S. - \$32  
 Canada or Mexico - \$17.50       Europe (Air Delivered) - \$25  
 Surface delivery to all other countries except Europe, Canada or Mexico - \$25 (Air delivery available on request)

Check enclosed (Bonus: one extra issue)

Please remit in U.S. funds —

Bill me.

Bill BankAmericard

Bill Master Charge

Card number \_\_\_\_\_ Expiration date \_\_\_\_\_

Signature \_\_\_\_\_ Name (please print) \_\_\_\_\_

Address \_\_\_\_\_

City \_\_\_\_\_ State/Country \_\_\_\_\_ Code \_\_\_\_\_



# DIRECTORY OF MICROCOMPUTER PRODUCTS MANUFACTURERS

If you have any additional questions about products described in this Guide, write direct to the company.

- ADVANCED MICROCOMPUTER PRODUCTS**  
P.O. Box 17329, Irvine, CA 92713
- AI CYBERNETIC SYSTEMS**  
P.O. Box 4691, University Park, NM 88003
- APPLE COMPUTER**  
20863 Stevens Creek Blvd., Cupertino CA 95014
- AXIOM**  
5932 San Fernando Rd., Glendale, CA 91202
- BYTE, INC.**  
1261 Birchwood Dr., Sunnyvale, CA 94086
- CANADA**  
P.O. Box 516, La Canada, CA 91011
- CENTER FOR THE STUDY OF THE FUTURE**  
4110 N.E. Alameda, Portland, OR 97212
- CENTRAL DATA**  
P.O. Box 1484, Station A, Champaign, IL 61820
- CGRS MICROTECH, INC.**  
P.O. Box 368, Southampton, PA 18966
- CHILD ODYSSEY ENTERPRISES**  
P.O. Box 137, Alamogordo, NM 88310
- COMMODORE BUSINESS MACHINES INC.**  
901 California Ave., Palo Alto, CA 94304
- COMP-SULTANTS, INC.**  
P.O. Box 1016, Huntsville, AL 35807
- COMPUCOLOR CORP.**  
P.O. Box 569, Norcross, GA 30091
- COMPUTALKER CONSULTANTS**  
P.O. Box 1951, Santa Monica, CA 90406
- COMPUTER CONVERSOR**  
1961 Old Middlefield Way, Mountain View, CA 94043
- COMPUTER POWER & LIGHT**  
12321 Ventura Boulevard, Studio City, CA 91604
- C.R.C. ENGINEERING**  
P.O. Box 6263, Bellevue, WA 98007
- CROMEMCO, INC.**  
2432 Charleston Rd., Mountain View, CA 94043
- CYBERNETIC MICRO SYSTEMS**  
2460 Embarcadero Way, Palo Alto, CA 04303
- CYBERSYSTEMS, INC.**  
4306 Governors Drive West, Huntsville, AL 35805
- DAJEN ELECTRONICS**  
7214 Springleaf Ct., Citrus Heights, CA 95610
- DATA ENGINEERING**  
P.O. Box 406, Southampton, PA 18966
- DIGITAL GROUP, THE**  
P.O. Box 6528, Denver, CO 80206
- E&L INSTRUMENTS**  
61 First St., Derby, CT 06418
- ECD**  
196 Broadway, Cambridge, MA 02139
- ECONOMY TERMINALS**  
P.O. Box 12261, Minneapolis, MN 55412
- EDITYPER SYSTEMS**  
26 Just Road, Fairfield, NJ 07006
- ELECTRONIC CONTROL TECHNOLOGY**  
P.O. Box 6, Union, NJ 07083
- ELECTRONIC PRODUCT ASSOCIATES, INC.**  
1157 Vega St., San Diego, CA 92110
- ELECTRONIC TOOL CO.**  
4736 W. El Segundo Blvd., Box 1315, Hawthorne, CA 90250
- EXPANDOR, INC.**  
612 Beatty Rd., Monroeville, PA 15146
- EXTENSYS CORP.**  
592 Weddell Drive, Suite 3, Sunnyvale, CA 94086
- FORETHOUGHT PRODUCTS**  
P.O. Box 386-C, Coburg, OR 97401
- FRANKLIN ELECTRIC CO.**  
733 Lakefield Rd., Westlake Vill., CA 91361
- GIMIX, INC.**  
1337 W. 37th Pl., Chicago, IL 60609
- GNAT COMPUTERS**  
7895 Convooy Ct., Unit 6, San Diego, CA 92111
- BILL GOQBOUT ELECTRONICS**  
P.O. Box 2355, Oakland Airport, CA 94614
- HAL COMMUNICATIONS**  
P.O. Box 365, Urbana, IL 61801
- HEATH COMPANY**  
Benton Harbor, MI 49022
- HEURISTICS, INC.**  
900 N. San Antonio Rd., Suite C1, Los Altos, CA 94022
- HOMESTEAD TECHNOLOGIES CORP.**  
891 Briarcliff Rd. NE, Suite B11, Atlanta, GA 30306
- IASIS, INC.**  
815 W. Maude Ave., Sunnyvale, CA 94086
- ICOM DIV., PERTEC**  
6741 Varief Ave., Canoga Park, CA 91303
- IMSAI MANUFACTURING CO.**  
14860 Wicks Boulevard, San Leandro, CA 94577
- INFINITE, INC.**  
1924 Waverly Place, Melbourne, FL 32901
- INTEL CORP.**  
3065 Bowers Ave., Santa Clara, CA 95051
- INTERNATIONAL DATA SYSTEMS**  
400 N. Washington, Suite 200, Falls Church, VA 22046
- INTERSIL, INC.**  
10900 N. Tantau Ave., Cupertino, CA 95014
- LEAR SIEGLER, INC., EID/DATA PRODUCTS**  
714 N. Brookhurst St., Anaheim, CA 92803
- LOGIC DESIGN, INC.**  
P.O. Box 3991, University Station, Laramie, WY 82071
- M&R ENTERPRISES**  
P.O. Box 61011, Sunnyvale, CA 94088
- MARTIN RESEARCH**  
3336 Commercial Ave., Northbrook, IL 60062
- MATROX ELECTRONIC SYSTEMS**  
Box 56, Ahuntsic Stn., Montreal, Que, Canada H3L 3N5
- MICON INDUSTRIES**  
252 Oak St., Oakland, CA 94607
- MICRO-BUILDERS INK**  
Box 28-D, 1 Marineview Plaza, Hoboken, NJ 07030
- MICRO COMPUTER DEVICES**  
564 S. Greenwood Ave., Montebello, CA 90640
- MICRO DESIGNS**  
499 Embarcadero, Oakland, CA 94606
- MICROCOMPUTER ASSOCIATES**  
2589 Scott Boulevard, Santa Clara, CA 95050
- MICROGRAPHICS**  
P.O. Box 2189, Station A, Champaign, IL 61820
- MICROLOGIC**  
P.O. Box 55494 Indianapolis, IN 46250
- MICROMATION**  
54 Union St., San Francisco, CA 94133
- MICRONICS, INC.**  
P.O. Box 3514, Greenville, NC 27834
- MIDWEST SCIENTIFIC INSTRUMENTS**  
220 West Cedar, Olathe, KS 66061
- MINITERM ASSOCIATES**  
Box 268, Bedford, MA 01730
- MITS**  
2450 Alamo S.E., Albuquerque, NM 87106
- MORROW'S MICRO-STUFF**  
P.O. Box 6194, Albany, CA 94706
- MOS TECHNOLOGY**  
950 Rittenhouse Rd., Norristown, PA 19401
- MOTOROLA**  
Educator II: **HEP/MRO OPERATIONS DIV.**  
785 W. 22nd St., Tempe, AZ 85282  
Evaluator, EXORCISER:  
**SEMICONDUCTOR PRODUCTS DIV.**  
3501 Ed Bluestein Blvd., Austin, TX 78721  
Micromodules:  
**SEMICONDUCTOR PRODUCTS DIV.**  
P.O. Box 20912, Phoenix, AZ 85036
- MOUNTAIN HARDWARE**  
P.O. Box 1133, Ben Lomond, CA 95005
- M.R.S.**  
P.O. Box 1220, Hawthorne, CA 90250
- MULLEN COMPUTER BOARDS**  
P.O. Box 6214, Hayward, CA 94545
- NATIONAL MULTIPLEX CORP.**  
3474 Rand Ave., South Plainfield, NJ 07080
- NATIONAL SEMICONDUCTOR CORP.**  
2900 Semiconductor Drive, Santa Clara, CA 95051
- NBL**  
Box 1115, Richardson, TX 75080
- NETRONICS**  
333 Litchfield Rd., New Milford, CT 06776
- NORTH STAR COMPUTERS**  
2465 Fourth St., Berkeley, CA 94710
- OHIO SCIENTIFIC INSTRUMENTS**  
11679 Hayden St., Hiram, OH 44234
- OLIVER AUDIO ENGINEERING, INC.**  
7330 Laurel Canyon Boulevard, North Hollywood, CA 91605
- PAIA ELECTRONICS**  
P.O. Box 14359, Oklahoma City, OK 73114
- PARASITIC ENGINEERING**  
P.O. Box 6314, Albany, CA 94706
- PERCOM DATA CO., INC.**  
4021 Windsor, Garland, TX 75042
- PERIPHERAL VISION**  
P.O. Box 6267, Denver, CO 80206
- PERSCI**  
4087 Glencoe Ave., Marina Del Rey CA 90291
- PICKLES & TROUT**  
P.O. Box 2276, Goleta, CA 93018
- POLYMORPHIC SYSTEMS**  
460 Ward Drive, Santa Barbara, CA 93111
- PROCESSOR TECHNOLOGY**  
6200 Hollis St., Emeryville, CA 94608

(Continued on page 120)

# ALTAIR<sup>TM</sup> COMPUTER CENTERS

TUCSON, AZ 85711  
4941 East 29th St.  
(602)-748-7363

BERKELEY, CA 94710  
1044 University Ave.  
(415)-845-5300

SANTA MONICA, CA 90401  
820 Broadway  
(213)-451-0713

DENVER, CO 80211  
2839 W. 44th Ave.  
(303)-458-5444

ATLANTA, GA 30305  
3330 Piedmont Road  
(404)-231-1691

PARK RIDGE, IL 60068  
517 Talcott Road  
(312)-823-2388

ANN ARBOR, MI 48104  
310 East Washington Street  
(313)-995-7616

MADISON HEIGHTS, MI 48071  
505-507 West 11 Mile St.  
(313)-545-2225

EAGAN, MN 55122  
3928 Beau D'Rue Drive  
(612)-452-2567

ST. LOUIS, MO 63130  
8123-25 Page Blvd.  
(314)-427-6116

DAYTON, OH 45414  
5252 North Dixie Drive  
(513)-274-1149

TULSA, OK 74135  
110 The Annex  
5345 East Forty First St.  
(918)-664-4564

BEAVERTON, OR 97005  
8105 SW Nimbus Ave.  
(503)-644-2314

LINCOLN, NB 68503  
611 N. 27th St. Suite 9  
(402)-474-2800

CHARLOTTE, N.C. 28205  
1808 E. Independence Blvd.  
(704)-334-0242

ALBUQUERQUE, NM 87110  
3120 San Mateo N.E.  
(505)-883-8282, 883-8283

ALBANY, NY 12211  
269 Osborne Road  
(518)-459-6140

NEW YORK, NY 10018  
55 West 39th Street  
(212)-221-1404

DALLAS, TX 75234  
3208 Beltline Road, Suite 206  
(214)-241-4088 Metro-263-7638

HOUSTON, TX 77036  
7302 Harwin Drive, Suite 206  
(713)-780-8981

RICHMOND, VA 23230  
4503 West Broad St.  
(804)-355-5773

SPRINGFIELD, VA 22150  
6605A Backlick Road  
(703)-569-1110

CHARLESTON, W.VA. 25301  
Municipal Parking Building  
Suite 5  
(304)-345-1360

## DIRECTORY OF MANUFACTURERS (Continued from page 119)

**PROKOTRONICS**  
439 Marsh St., San Luis Obispo, CA 93401

**QUAY CORP.**  
P.O. Box 386 Freehold, NJ 07728

**RADIO SHACK**  
2617 W. 7th St., Fort Worth, TX 76107

**RCA SOLID STATE DIV.**  
Route 202, Somerville, NJ 08876

**GEORGE RISK INDUSTRIES**  
G.R.I. Plaza, Kimball, NB 69145

**RIVERSIDE ELECTRONIC DESIGN**  
1700 Niagara St. Buffalo, NY 14207

**RMQ SYSTEMS/COMPUTER KITS, INC.**  
1044 University Ave., Berkeley, CA 94710

**RO-CHE SYSTEMS**  
7107 Mammoth Ave., Van Nuys, CA 91405

**SCOPE DATA, INC.**  
3728 Silver Star Rd., Orlando, FL 32808

**SEALS ELECTRONICS**  
P.O. Box 11651, Knoxville, TN 37919

**SHARP & ASSOCIATES**  
Box 26045, Lakewood, CO 80226

**SMOKE SIGNAL BROADCASTING**  
Box 2017, Hollyhock, CA 90028

**SOLID STATE MUSIC (CYBERCOM)**  
2102A Walsh Ave., Santa Clara, CA 95050

**SOROC TECHNOLOGY**  
3074 E. Miraloma Ave., Anaheim, CA 92806

**SOUTHWEST TECHNICAL PRODUCTS (SWTP)**  
219 W. Rhapsody, San Antonio, TX 78216

**STM SYSTEMS, INC.**  
P.O. Box 258, Mont Vernon, NH 03057

**SYLVAN HILLS LABORATORY, INC.**  
#1 Sylvanway, Box 239, Stratford, MO 65757

**SYNETIC DESIGNS**  
1452 Prospect Dr., Pomona, CA 91766

**TARBELL ELECTRONICS**  
20620 South Leapwood Ave., Suite P., Carson, CA 90746

**TECHNICAL DESIGN LABS (TDL)**  
Research Park, Building H, 1101 State Rd., Princeton, NJ 08540

**TECHNICO, INC.**  
9130 Red Branch Rd., Columbia, MD 21045

**TED**  
Box 4122, Madison, WI 53711

**TEXAS INSTRUMENTS**  
Box 1433, M/S 653 (Attn: TM990), Houston, TX 77001

**U.S. ROBOTICS, INC.**  
P.O. Box 5502, Chicago, IL 60680

**VAMP, INC.**  
Box 29315, Los Angeles, CA 90029

**VECTOR ELECTRONIC CO.**  
12460 Gladstone Ave., Sylmar, CA 91342

**VECTOR GRAPHIC, INC.**  
717 Lakefield Rd., Westlake Village, CA 91361

**VIDEO TERMINAL TECHNOLOGY**  
P.O. Box 60845, Sunnyvale, CA 94088

**WESTERN DATA SYSTEMS**  
3650 Charles St., Santa Clara, CA 95050

**WINTEK CORP.**  
902 N. 9th St., Lafayette, IN 47904

**WYLE COMPUTER PRODUCTS**  
3200 Magruder Boulevard, Hampton, CA 23666

**XYBEK**  
P.O. Box 1631, Cupertino, CA 95014

**ZILOG INC.**  
10460 Bubb Rd., Cupertino, CA 95014

## ELECTRONIC EXPERIMENTERS HANDBOOK - 1978

### ADVERTISERS INDEX

READER SERVICE NO.	ADVERTISER	PAGE NO.
1	A P Products	26, 27
2	Avanti Research & Development, Inc	94
3	Byte	118
	Cleveland Institute of Electronics, Inc	34, 35, 36, 37
4	Continental Specialties Corporation	12, 13
6	Datak Corporation	113
7	Digital Group, The	FOURTH COVER
8	EICO	105
9	ETI Products	111
10	Greenlee Tool Co	79
5	Heath Company	53, 54, 55
	Interface Age Magazine	85
11	James Electronics	2
12	Jensen Tools & Alloys	114
13	Kester Solder	115
14	MITTS	120, THIRD COVER
	Martin Research	102
	NRI Schools	17, 18, 19
15	Newman Computer Exchange	107
16	OK Machine & Tool Corporation	98
17	OK Machine & Tool Corporation	101
18	OK Machine & Tool Corporation	117
19	Ohio Scientific Instrument	6
26	Peripheral Vision, Inc.	81
20	Radio Hut	4
21	S.D. Sales Co	86
22	Sabtronics	1
23	Southwest Technical Products Corp	SECOND COVER
24	Techni-Tool Inc	110
25	Wahl Clipper Corporation	105

# Ability.

## It Comes Naturally With The Altair™ 8800b

The Altair 8800b from MITS: the second generation design of the microcomputer that started it all. The mainframe that has the abilities everyone is demanding from microcomputers today:

### Expand-ability:

The Altair 8800b power supply and one-piece, 18-slot mainboard allow efficient and easy expandability for memory and I/O options. All Altair PC boards are designed to give you maximum capability/lowest power usage possible per board. This means that for each slot used you get more features and require less power than with any of the "off-brand" Altair-bus-compatible boards.

Whether you buy an entire system up front or choose to expand gradually, it's easy to get the configuration you need with the complete family of Altair peripheral equipment, including floppy disk, line printer, audio cassette record interface, A/D converter, PROM programmer, serial and parallel I/O boards.

choice of four different memory boards and many others.

### Reli-ability:

The unique design features of the Altair 8800b, which have set the standard for the microcomputer industry, make it the most reliable unit of its kind. The Altair 100-pin bus, the now-standard design used by many imitators, has been "standard" all along at MITS. The unique Front Panel Interface Board on the Altair 8800b isolates and filters front panel noise before it can be transmitted to the bus. The all-new CPU board utilizes the 8080A microprocessor, Intel 8224 clock generator and 8216 bus drivers.

### Flex-ability:

Meeting the diversified demands of an ever-increasing microprocessor market requires flexibility: not just hardware flexibility but

software flexibility as well. MITS software, including the innovative Altair BASIC language, allows the full potential of the Altair 8800b computer to be realized.

8K ALTair BASIC has facilities for variable length strings with LEFT\$, RIGHT\$, and MID\$ functions, a concatenation operator, and VAL AND STR\$ functions to convert between strings and numbers.

Extended ALTair BASIC allows integer, single and double precision variables, automatic line numbering and renumbering, user-defined string functions, PRINT USING for formatted output and a powerful EDIT command for editing program files during or after entry. Extended statements and commands include IF... THEN... ELSE, LIST and DELETE program lines, SWAP variables and Trace On and Off for debugging.

Disk ALTair BASIC has all the features of Extended BASIC with the additional capability to maintain sequential and random access disk files. Utilities are provided for formatting disks and printing directories.

In all versions of ALTair BASIC you get the ease and efficiency of BASIC for the solution of real world problems.

Package II, an assembly language development system for the Altair 8800b, includes system monitor, text editor, assembler and debug.

### Afford-ability:

Prices for the Altair 8800b start at \$840.00 for a kit and \$1100.00 for an assembled unit (all documentation included).

For a complete listing of prices on all Altair products and a free brochure, contact:

MITS, Inc.  
2450 Alamo SE  
Albuquerque, N.M. 87106  
(505) 243-7821

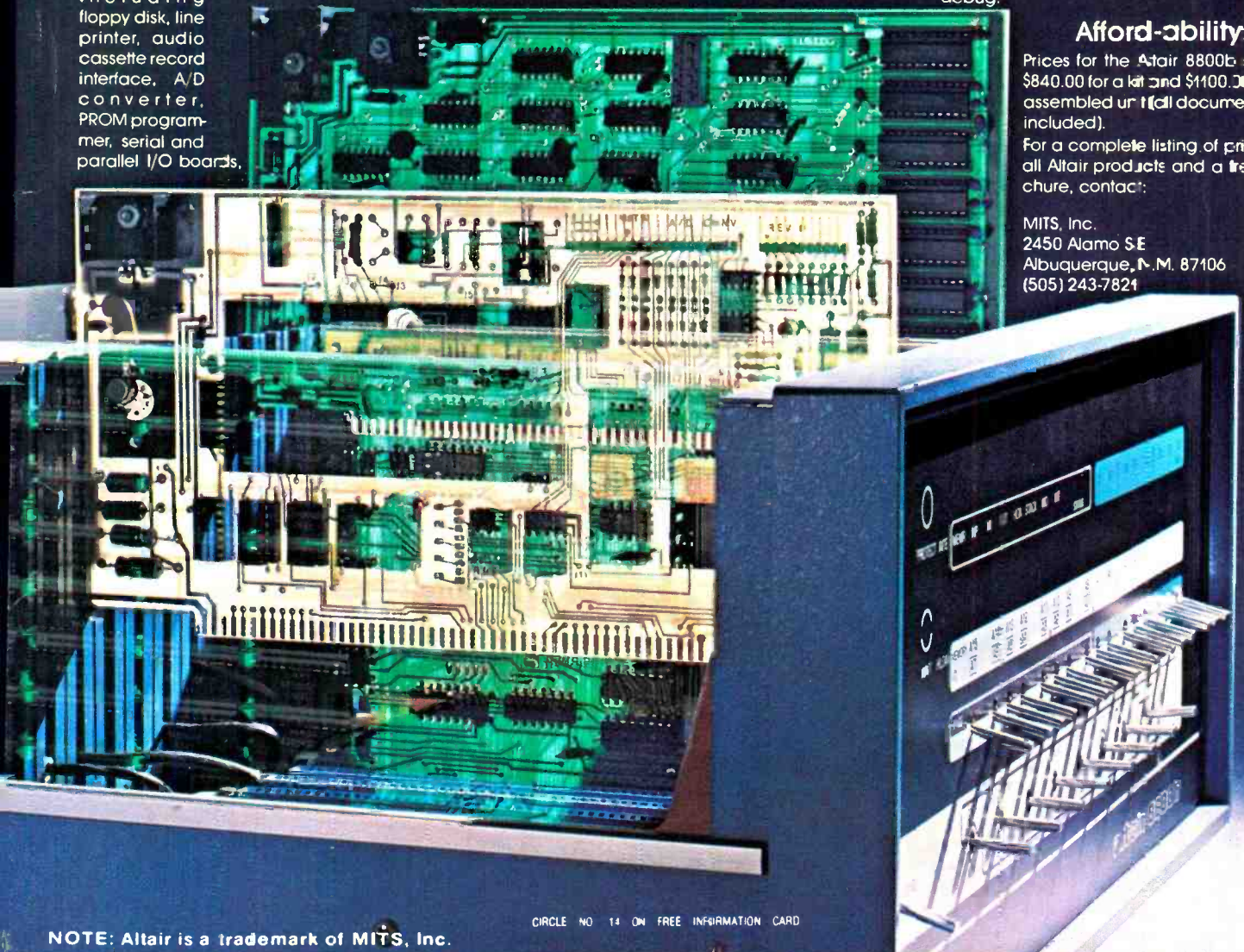

# Meet The Digital Group



Clockwise from top left: Impact Printer, CPU, 9" Video Monitor, Cassette Storage System with Four Drives, Keyboard, Dual Floppy.

If you are seriously considering the purchase of a microcomputer system for personal or business use... or just beginning to feel the first twinges of interest in a fascinating hobby... the Digital Group is a company you should get acquainted with.

For many months now, we've been feverishly (and rather quietly) at work on our unique, high-quality product—a microcomputer system designed from the inside out to be the most comprehensive, easy-to-use and adaptable system you'll find anywhere. And our reputation has been getting around *fast*. In fact, you may have already heard a little something about us from a friend. We've found our own best salesmen are our many satisfied customers.

There's a good reason. Simply, the Digital Group has a lot to offer: state-of-the-art designs, a totally complete systems philosophy, unexcelled quality, reasonable software, affordable prices and the promise that our products will not become rapidly obsolete, even in this fast-moving, high-technology field.

## The Advantages

Here are a few specific advantages of our product line:

- We offer interchangeable CPUs from different manufacturers (including the new "super chip"—the Z-80 from Zilog) which are interchangeable at the CPU card level. That way, your system won't become instantly obsolete with each new design breakthrough. The major portion of your investment in memory and I/O is protected.
- Digital Group systems are complete and fully featured, so there's no need to purchase bits and pieces from different manufacturers. We have everything you need, but almost any other equipment can be easily supported, too, thanks to the universal nature of our systems.
- Our systems are specifically designed to be easy to use. With our combination of TV, keyboard, and cassette recorder, you have a system that is quick, quiet, and inexpensive. To get going merely power on, load cassette and go!

the digital group

P.O. Box 6528  
Denver, Colorado 80206  
(303) 777-7133

OK, I'd like to get to know you guys better. Send me the whole package!

Name \_\_\_\_\_

Address \_\_\_\_\_

City/State/Zip \_\_\_\_\_

- Design shortcuts have been avoided—all CPUs run at full maximum rated speed.
- All system components are available with our beautiful new custom cabinets. And every new product will maintain the same unmistakable Digital Group image.

## The Features

Digital Group Systems—CPUs currently being delivered: Z-80 by Zilog, 8080A/9080A, 6800, 6500 by MOS Technology.

All are completely interchangeable at the CPU card level. Standard features with all systems:

- Video-based operating system
- Video/Cassette Interface Card
  - 512 character upper & lower case video interface (1024 optional)
  - 100 character/second digitally synthesized audio cassette interface
- CPU Card
  - 2K RAM, Direct Memory Access (DMA)
  - Vectored Interrupts (up to 128)
  - 256 byte 1702A bootstrap loader
  - All buffering, CPU dependencies, and housekeeping circuitry
- Input/Output Card
  - Four 8-bit parallel input ports
  - Four 8-bit parallel output ports
- Motherboard

Prices for standard systems including the above features start at \$475 for Z-80, \$425 for 8080 or 6800, \$375 for 6500.

## More

Many options, peripherals, expansion capabilities and accessories are already available. They include rapid computer-controlled cassette drives for mass storage, printers, color graphics interfaces, memory, I/O, monitors, prom boards, multiple power supplies, prototyping cards and others. Software packages include BASICs, Assemblers, Disassemblers, Text Editors, games, ham radio applications, software training cassettes, system packages and more (even biorhythm).

## Sounds neat—now what?

Now that you know a little about who we are and what we're doing, we need to know more about you. In order for us to get more information to you, please take a few seconds and fill in our mailing list coupon. We think you'll be pleased with what you get back.