

RADIO TV REPAIR

FALL-WINTER 75c

**SAVE OVER
\$100 ANNUALLY!
BE YOUR OWN
SERVICEMAN!**

FIX YOUR OWN

- TV, AM, FM Sets
- Walkie-Talkies
- Tape Recorders
- CB Rigs
- Stereos
- Shortwave Receivers

**BONUS! DOLLAR SAVING FEATURE
—HOW TO ADJUST YOUR COLOR TV**



S&M's SUPERSENSITIVE DARKROOM METER

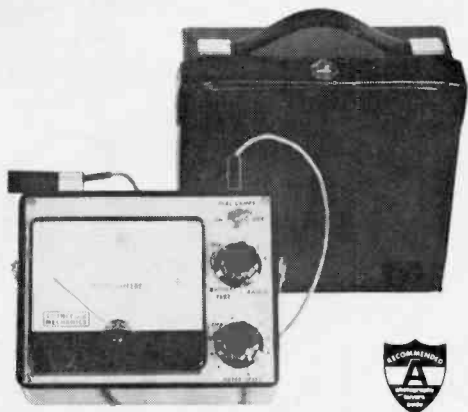

You get your money's worth when you own an S&M A-3 Supersensitive Darkroom Meter.

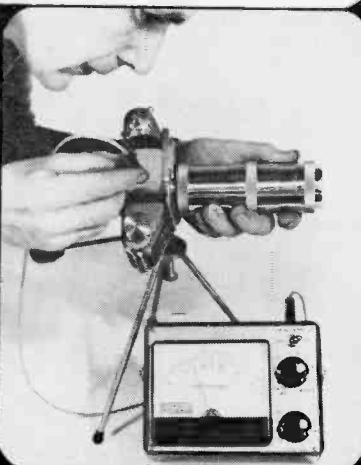

Use the coupon below to order your meter today. Satisfaction guaranteed!

SCIENCE & MECHANICS—KIT DIVISION
505 Park Avenue / New York, N.Y. 10022

RTVR-967

Please send the S&M, A-3 Supersensitive Darkroom Meter as I've indicated below. I understand that if I am not satisfied, I may return the meter within 10 days for a complete refund.

Add 10% for Canadian and foreign orders. N.Y.C. residents add 5% for sales tax.

- | | |
|--------------------------------------|---|
| _____ \$44.50—in kit form | _____ \$6.50—Easel Probe |
| _____ \$49.50—fully assembled | _____ \$6.50— $\frac{3}{8}$ -inch Miniature Probe |
| _____ \$ 4.95—Carrying Case | _____ Enclosed \$3.00 deposit, |
| _____ Check or money order enclosed, | Ship COD, plus postage & COD |
| _____ ship post-paid | charges |

Name (PLEASE PRINT) _____

Address _____

City _____ State _____ Zip _____

**U.S. Camera says,
"The meter is a
marvelously sensitive
and accurate
instrument."**

- \$44.50 in Kit form*
- \$49.50 Fully assembled*
- *Carrying case included
- \$4.95 extra Carrying case

This Model A-3 Meter is named the "Darkroom Meter" because it has been so widely accepted for reading enlarger easel exposures. It has earned a reputation as a precision instrument in color studio photography, copy work, portraiture, and available light photography. You can use it with movie cameras and with single lens reflex cameras. The A-3s are also used for ground glass exposure readings with microscopes, telescopes and can even be set up for use as a densitometer.

An exclusive feature of this versatile instrument is its standard plug-in probe assembly with three foot flexible cable. This probe utilizes the newest Clairex Corp. CL-505L cadmium sulfide photocell—the best grade available today—balanced for color, and the complete range of exposures from dim available light to full bright sun light. Its field of view is 43 degrees, equal to normal camera lens angles.

The meter is supplied with a 5-inch, easy-to-read computer with four-range selection and EV-EVS-LV settings to give F stops from .7 to 90 and list exposure time from 1/15,000 second to 8 hours.

The 4½-inch dial of the meter is self-illuminated with built-in battery lamps. You read on 4 sensitivity ranges, therefore the meter dial and selector switch give you an equivalent of 18 inches of total dial space for reading accuracy. The paper speed control knob is used to set sensitivity to match the various grades of printing papers. The meter sensitivity is sufficient to detect the light of a match 10 feet away.

This S&M Light Meter is supplied with a probe holding bracket for darkroom work. An accessory easel probe $\frac{3}{8}$ -inch (see photo) is recommended for use with high speed enlarging papers. The standard $\frac{3}{8}$ -inch diameter probe can be used to read a $\frac{1}{2}$ -inch circle on the viewing glass of many SLR's. To read a smaller target through the lens of Exactas, Practicas, etc., order the $\frac{3}{8}$ -inch diameter probe which has a $\frac{1}{4}$ wide photocell.

Whether you buy the S&M A-3 Meter as an easy-to-assemble kit, or completely factory-assembled, you can be sure you have the advantage of owning a rugged and dependable instrument. A complete manual tells you step-by-step how to assemble the instrument, how to use it for profitable photography and how to keep it working right for years

253 ways to win yourself a RAISE IN PAY

Dozens of new careers are open to you with I.C.S. training. More than 250 job-related courses. Oldest, largest correspondence institution, 7,500,000 students since 1890. Learn facts, theories, practical applications. Instructors guide you,

answer your questions. Easy-to-read, illustrated texts, written by authorities, are yours to keep. Famed I.C.S. diploma to graduates. Convenient payment plan. Take charge of your future now. Send our coupon for three FREE booklets.

ACCOUNTING
Accounting for Business
Programmers
Accounting (Canadian)
Auditing Business Law
Cost Accounting
C.P.A. Review
Estate & Trust Accounting
Executive Accounting
Federal Tax
General Accounting
Industrial Accounting
Junior Accounting
Legal Accounting
Office Accounting
Personal Income Tax
Procedure
Practical Accounting
Public Accounting
Small Business Accounting
Starting & Managing a
Small Bookkeeping Ser.

**ARCHITECTURE
AND BUILDING**
Arch. Drawing & Designing
Architecture
Building Contractor
Building Estimator
Building Inspector
Building Maintenance
Carpenter-Builder
Carpentry & Millwork
House Planning & Interior
Design
Mason Painting Contr.
Reading Arch. Blueprints
Review in Arch. Design &
Practice
Review of Mech. Systems
in Buildings

ART
Amateur Artist
Commercial Art
Commercial Cartooning
Illustrating with Options:
—Magazine
—Advertising Layout
—Illustration
Interior Decorating
Oil Painting for Pleasure
Show Card & Sign Prod.
Show Card Writing
Sign Painting & Designing
Sketching & Painting

AUTOMOTIVE
Automatic Transmission
Specialist
Automobile Body
Rebuilding & Refinishing
Automobile Electrical Tech.
Automobile Engine Tune-Up

Automobile Technician
Automotive Mechanic
Diesel-Gas Motor Vehicle
Engines

BUSINESS
Advertising
Basic Inventory Control
Business Administration
Canadian Business Courses
Condensed Bus. Practice
Direct Mail & Mail
Order Advertising
Industrial Psychology
Magazine & Newspaper
Advertising
Managing a Small Store
Marketing
Marketing Management
Marketing Research
Modern Exec. Management
Office Automation
Office Management
Production Management
Purchasing Agent
Retail & Local Advertising
Retail Bus. Management
Retail Merchandising
Retail Selling
Systems and Procedures
Analysis

CHEMICAL
Analytical Chemistry
Chemical Engineering
Chemical Engineering
Unit Operations
Chemical Laboratory Tech.
Chemical Process Operator
Elements of Nuclear Energy
General Chemistry
Instrumental Laboratory
Analysis

**CIVIL
ENGINEERING**
Civil Engineering
Construction Eng'g
Technology
Highway Engineering Tech.
Principles of Surveying
Reading Highway Bl'pts
Reading Structural
Blueprints
Sanitary Engineering Tech.
Sewage Plant Operator
Structural Eng'g Tech.
Surveying and Mapping
Water Works Operator

COMPUTERS
COBOL Programming
Fortran Programming for
Engineers

Programming for Digital
Computers
Programming the IBM
1401 Computer
Programming the IBM
SYSTEM/360 Computer

DRAFTING
Aircraft Drafting
Architectural Drafting
Design Drafting
Drafting Technology
Electrical Eng'g Drafting
Electronic Drafting
Introductory Mech. Draft.
Mechanical Drafting
Pressure-Vessel and Tank
Print Reading
Sheet Metal Layout for
Air Conditioning
Structural Drafting

ELECTRICAL
Electric Motor Repairman
Electrical Appliance Ser.
Electrical Contractor
Electrical Engineering
(Power option or
Electronic option)
Electrical Engineering Tech.
Electrical Instrument Tech.
Industrial Electrical Tech.
Power Line Design
and Construction
Power Plant Operator
(Hydro or Steam option)
Practical Electrician
Practical Lineman
Reading Elec. Blueprints

**ENGINEERING
(Professional
Refresher Courses)**
Chemical Civil Electrical
Engineer-in-Training
Industrial Mechanical
**ENGLISH AND
WRITING**
Better Business Writing
Free Lance Writing
for Fun & Profit
Introductory Technical
Writing
Modern Letter Writing
Practical English
Short Story Writing

HIGH SCHOOL
High School Business
High School (Canadian)
High School College
Prep. (Arts)
High School College Prep.
(Engineering & Science)

High School General
High School Mathematics
High School Secretarial
High School Vocational

LANGUAGES
(Edited by Berlitz)
French German
Italian Spanish

LEADERSHIP
Supervision
Industrial Foremanship
Industrial Supervision
Modern Woman
as a Supervisor
Personality Development
Personnel-Labor Relations

MATHEMATICS
Advanced Mathematics
Mathematics and Mechanics
for Engineering
Mathematics and Physics
for Technicians
Mathematics and Physics
for Engineering
Modern Elementary Stat.

MECHANICAL
Aircraft & Power
Plant Mechanics
Hydraulic & Pneu. Power
Industrial Engineering
Industrial Management
for Engineers
Industrial Eng'g Tech.
Industrial Instrumentation
Machine Design
Mechanical Engineering
Quality Control
Safety Eng'g Tech'g'y
Tool Design Value Analysis
Vibration Analysis
and Control

PETROLEUM
Natural Gas Production
& Transmission
Oil Field Technology
Petroleum Production
Petroleum Prod. Eng'g
Petroleum Refinery Oper.
Pipeline Engineering Tech.

PLASTICS
Design of Plastic Products
Plastics Technician

**PLUMBING, AIR
CONDITIONING**
Air Conditioning
Air Conditioning Maint.
Domestic Heating with
Oil & Gas
Domestic Refrig. Heat'g

Heating & Air Conditioning
with Drawing
Industrial Air Conditioning
Industrial Heating
Pipe Fitting Plumbing
Plumbing & Heating
Plumbing & Heating Est.
Practical Plumbing
Refrigeration & Air Cond.

PULP AND PAPER
Paper Machine Operator
Paper Making, Pulp Making
Pulp & Paper Engineering
Pulp & Paper Making
SALESMANSHIP
Creative Salesmanship
Real Estate Salesmanship
Sales Management
Salesmanship
SECRETARIAL
Clerk-Typist Commercial
Executive Secretary
Legal Secretary
Medical Secretary
Professional Secretary
Shorthand Stenographic
Typewriting

SHOP PRACTICE
Drill Operator
Foundry Practice
Industrial Metallurgy
Lathe Operator
Machine Shop Inspection
Machine Shop Practice
Machine Shop Practice &
Toolmaking
Metallurgical Eng'g
Technology
Milling Machine Operator
Multicraft Maintenance
Mechanic
Practical Millwrighting
Reading Shop Prints
Rigging
Tool Eng'g Tech'g'y
Tool Grinder Toolmaking
Turret Lathe Operator
Welding Engineering Tech.
Welding Processes

**STEAM AND
DIESEL POWER**
Boiler Inspector
Industrial Building Eng'g
Power Plant Engineering
Stationary Diesel Engines
Stationary Fireman
Stationary Steam Eng'g

TEXTILES
Carding and Spinning

Dyeing & Finishing
Loom Fixing Spinning
Textile Designing
Textile Mill Supervisor
Textile Technology
Warping and Weaving

TRAFFIC
Motor Traffic Management
Railway Rate Clerk
Traffic Management

**TV-RADIO-
ELECTRONICS**
Color Television Principles
& Servicing
Communications Techn'gy
Electronic Fundamentals
Electronic Fundamentals
(Programmed)
Electronic Fundamentals
with Electronic Equip-
ment Training
Electronic Instrumentation
& Servo Fundamentals
Electronic Principles for
Automation
Electronics and Applied
Calculus
Electronics Technician
First Class Radiotelephone
License
Fundamentals of Electronic
Computers
General Electronics
General Electronics with
Electronic Equip. Trns.
Hi-Fi Stereo and Sound
Systems Servicing
Industrial Electronics
Industrial Electronics Eng.
Industrial Electronics
Engineering Technician
Numerical Control
Electronics & Maint.
Practical Radio-TV Eng'g
Practical Telephony
Principles of Radio-
Electronic Telemetry
Principles of Semiconductor-
Transistor Circuits
Radio Servicing with
Equipment Training
Radio & TV Servicing
Radio & TV Servicing with
Equipment Training
Second Class Radiotele-
phone License
Sound Systems Specialist
Telephony Electronics and
Radio Communications
TV Receiver Servicing
TV Technician

Clip coupon here ... take your first step to real success! I.C.S., Scranton, Penna. 18515

I C S
Accredited member,
National Home Study Council.
Convenient payment plan.
Special Canadian courses
In French and English.
Approved for veterans
under the new G. I. Bill.
Special rates to members
of the U. S. Armed Forces.

INTERNATIONAL CORRESPONDENCE SCHOOLS Dept. R0192J, Scranton, Penna. 18515
(In Hawaii: P.O. Box 418, Honolulu. Canadian residents mail to Scranton, Penna. Further
service handled through I.C.S. Canadian Ltd.)

Without cost or obligation, rush me your famous "Success Package" —(1) "How to Succeed" booklet,
(2) sample lesson demonstrating I. C. S. method,
(3) catalog for program of study I'm interested in: _____

(Print name of course. See list.)

Mr. _____ Age _____
Miss _____
Mrs. _____
Address _____
City _____ State _____ Zip Code _____
Occupation _____ Employed by _____ Working Hours _____ A.M. to _____ P.M.

CONTENTS

The Thinking Man's Answer To TV Servicing You'll make quick work of dirty work if you'll only plan ahead.....	11
The Most From Your B&W Set How to adjust each and every control for best possible pix.....	15
Look Before You Listen For stereo ills, eagle eyes take over where golden ears leave off.....	23
Soup-Up For SW Sets The sure route to super reception on the shortwave bands.....	29
Foreign Tube Replacement Guide The American equivalent for just about any foreign tube.....	32
On The Care And Feeding Of Tape Recorders Do's—and don'ts—on the proper rearing of tape recorders.....	36
What To Do For Truest Blue Perfect color for the man who'll settle for nothing less.....	41
How To Save Money By Checking Tubes At Home Drugstore testers be damned—buy your own and know for sure.....	49
Tuning Up The All-American 5 Step-by-step procedures applicable to any AM set.....	53
New Life For Old Tuners Tips on rejuvenating the FM greats of yesteryear.....	59
So You Want To Replace A Boob Tube Pic-tube replacement the goof-proof way.....	71
Your Key To TV's Quick & Easy The generator that's a must for every color-TV do-it-himselfer.....	78
Erecting A TV Tower The straight scoop on tall masts for the boondock crew.....	79
Rx For WTs New life for walkie-talkies begins with a shot in the wiper arm.....	85
How To Change A Color-TV Tube We provide the know-how; you supply the elbow grease.....	89
CB Servicing Simplified Proven techniques for making your CB rig light up and live.....	95
DEPARTMENTS	
Why This Issue Can Save You Money	3
Service Shop Tips	5
TV Buzz—Cartoon page	70
Classified Ads	99

RADIO TV REPAIR

SAVE OVER \$100 ANNUALLY! BE YOUR OWN SERVICEMAN!

FIX YOUR OWN

- TV, AM, FM Sets
- Walkie-Talkies
- Tape Recorders
- CB Rigs
- Stereos
- Shortwave Receivers

BONUS! DOLLAR SAVING FEATURE—HOW TO ADJUST YOUR COLOR TV



Why This Issue Can Save You Money

YOU CAN SAVE over \$100 annually by following the simple servicing procedures outlined in this issue of **RADIO-TV REPAIR**. The only publication of its kind on the newsstands, **RADIO-TV REPAIR** is designed to save you money by making it possible for you to be your own serviceman.

In this, the Fall/Winter 1967 edition, you will find everything you need to know to undertake all but the most advanced repair of TV sets (both color and black-and-white), AM radios, FM tuners, tape recorders, CB transceivers, walkie-talkies, stereo amplifiers, and shortwave receivers. There are even detailed instructions on how to erect a TV tower, an undertaking that is well within almost anyone's capabilities and that could in itself result in savings of \$50, \$100, or more.

In the case of TV sets, you will find explicit, step-by-step instructions for replacing the component most likely to cause trouble: the picture tube itself. Procedures for color sets and black-and-white sets are presented separately, since changing a color tube is a far more complicated undertaking. Once the replacement is completed, you will be ahead on three counts: 1) you will have a set that performs like new, 2) you will have the satisfaction of having made the repair yourself, 3) you will have saved all service charges.

Still another article on TV repair (entitled "The Thinking Man's Approach to TV Servicing") actually tells you what to look for *before* you call a serviceman. Studies indicate that service calls can often be avoided if the owner knows the probable cause and remedy for a particular malady. By listing typical symptoms and their causes, this article can take the guesswork out of TV repair for any intelligent set-owner. ■

SHOOT TV TROUBLE FAST

With H. G. Cisin's Copyrighted RAPID "TV TROUBLE SHOOTING METHOD"

Without experience or knowledge, this guaranteed new method of servicing TV sets enables you to **DIAGNOSE** TV troubles as rapidly as an expert. **NO THEORY—NO MATH—YOU** can locate all faults in record-breaking time regardless of make or model. **"TV TROUBLE SHOOTING METHOD"** is the most valuable aid to TV servicing ever written. Be a TV Trouble Diagnostician. Increase your present earnings. Open your own Profitable Business or get a high-paying skilled job.

It's all in this book . . .

Nothing more to Pay—Nothing else to Buy

Alphabetically listed are 85 picture troubles, over 58 raster and 17 sound troubles. By this unique copyrighted method you know EXACTLY WHERE the trouble is; plus step-by-step instructions, including 89 RAPID CHECKS, help to find faulty part. 13 IMPORTANT PRELIMINARY CHECKS NEED NO INSTRUMENTS! Of the 89 Rapid Checks, OVER 45 ALSO REQUIRE NO INSTRUMENTS! Rapid checks include emergency checks for distorted pictures, defective tubes including PIX tube, plus 57 others ALL EXPLAINED IN SIMPLE LANGUAGE, PERFORMED WITHOUT INSTRUMENTS. MANY CHECKS USE THE PICTURE TUBE AS A GUIDE.

H. G. Cisin, the author, is the inventor of the AC/DC midjet radio. He licenses RCA, AT&T, etc. He has also trained thousands of technicians now owning their own prosperous TV service organizations or holding highly paid TV positions. His years of experience are embodied in this remarkable new book.

Guaranteed Money Back in 5 Days if Not Satisfied!

ABSOLUTELY FREE with each order: Your choice of Cisin's newest books: **BASIC ELECTRICITY—Vol. 1** or **TV-RADIO TUBE SUBSTITUTION GUIDE**. These sell for 50¢ ea. **ACT NOW—get 2 books postpaid at cost of only one!**

\$1 Post-paid

RUSH COUPON NOW!

H. G. CISIN, Consulting Engineer—Dept. RE-9
Amagansett, N. Y.
Enclosed find \$1. Rush Trouble Shooting Method and free book marked above (if not marked Basic Elec. will be sent).
 Send all 3 books. Enclosed find \$1.50

Name

Address

City..... Zone..... State.....

CB's SPECTACULAR!

Everyman's communications system—that's CB. And whether you're an old salt or a rank beginner the 1967 **CB BUYERS' GUIDE** is chock full of nifty needed know-how, know-why, and know-when on the biggest radio service in the world. Everything, absolutely everything, on CB from base station to boat station is included. You'll find complete, easy-to-understand lab checks on 75 CB rigs; the low-down on what CB can do for you; the full scoop on CB organizations. Get with it—zero in on where the action is—with the 1967 Edition of **CB BUYERS' GUIDE**—at your local newsstand now!

World Famed BREVETTATA TEAR GAS PISTOL

Appearance of this fine tear gas weapon is similar to real gun. It is ideal for people who work in lonely, dark locations and require protection. Men give this gun to wives and daughters for night security. Many industrial applications. Shooting of gun stops aggressor without permanently injuring him. Neither permit nor license is needed, but it is not sold to minors. It fires six cartridges without reloading. Each gun comes with six tear gas shells and six blanks for practice and is shipped prepaid. Gun unit prices include. 12 shells and all shipping costs.



- 1 Gun-unit at \$13.07
- 2 Gun-units at \$22.86 (\$11.43 ea.)
- 3 Gun-units at \$29.94 (\$ 9.98 ea.)
- 4 Gun-units at \$35.16 (\$ 8.79 ea.)

Extra boxes of ten tear gas shells at \$1.50 per box (prepaid with gun orders). Extra boxes of blanks at \$1.25 per box.

UNITED SAFETY SUPPLY CO.
310 West 9th Street
Kansas City 9TR, Missouri 64105

MICRO

SINCE 1957

Not connected with any other Mail Order Tube Co.

LARGE SELECT STOCK

DEPENDABLE FAST SERVICE

35¢ ea. in lots of 100

37¢ per tube

WE HAVE PICTURE TUBES

Send For
**FREE Tube List &
Special Purpose Tubes**

MICRO ELECTRON TUBE CO.

110 MARTIN ST., PATERSON, N. J.

All tubes sent postage pd. Send 35¢ handling chg. on orders under \$5. Send 25% on C.O.D.'s. Send approx. postage on Canadian & foreign orders.

FREE!



518 PAGES

Shop by mail and save at Allied, world's largest electronics headquarters. Hundreds of money-saving values. **NO MONEY DOWN.** Up to 2 years to pay!

MAIL COUPON BELOW

ALLIED RADIO, Dept. 52-J,
P.O. Box 4398, Chicago, Ill. 60680

NAME (Please Print)

ADDRESS

CITY

STATE

ZIP

1968 ALLIED CATALOG

SAVE ON:

- Famous Knight-Kits®
- Stereo HI-FI
- Tape Recorders, Tape
- CB 2-Way Radios
- Walkie-Talkies
- FM-AM & AM Radios
- Shortwave Receivers
- Portable TV
- Phonographs
- Amateur Gear
- Intercoms & PA
- Automotive Electronics
- Test Instruments
- TV Antennas & Tubes
- Power Tools, Hardware
- Tubes, Transistors
- Parts, Batteries, Books

RADIO TV REPAIR

FALL/WINTER 1967

Editor

RICHARD A. FLANAGAN
KQD2566

Service Editor

W. KRAG BROTTY
KQD2828

Editorial Assistant

HELEN PARKER

Art Editor

JIM MEDLER

Editor In Chief

JULIAN M. SIENKIEWICZ
WA2CQL, KMD4313

Art Director

ANTHONY MACCARRONE

Associate Art Director

EUGENE F. LANDINO III

Cover Art Director

IRVING BERNSTEIN

Art Associate

BARBARA GABRIEL

Advertising Manager

JIM CAPPELLO

Production Director

LEONARD F. PINTO

Production Manager

CARL BARTEE

Assistant Production Manager

MICHELLE WOLFFS

Promotion Manager

DAVID COHN

Kit Division Manager

WILFRED M. BROWN

President and Publisher

B. G. DAVIS

Executive Vice President and Assistant Publisher

JOEL DAVIS

Vice President and Editorial Director

HERB LEAVY, KMD4529



RADIO TV REPAIR is published by SCIENCE & MECHANICS PUBLISHING CO., a subsidiary of Davis Publications, Inc. Editorial, business and subscription offices: 505 Park Ave., New York, N.Y. 10022. Advertising Offices: New York, 505 Park Ave., 212-PL-2-6200; Chicago: 520 N. Michigan Ave., 312-527-0330; Los Angeles: 1709 W. 8th St., 213-483-5317; Atlanta: Pirnie & Brown, 3108 Piedmont Rd., N.E., 404-233-6729; Long Island: Len Osten, 9 Garden Street, Great Neck, N.Y. 516-487-3305; Southwestern advertising representative: Jim Wright, 4 N. Eighth St., St. Louis, 314-241-1965

EDITORIAL CONTRIBUTIONS must be accompanied by return postage and will be handled with reasonable care; however, publisher assumes no responsibility for return or safety of manuscripts, art work, or photographs. Contributions should be addressed to the Editor, RADIO TV REPAIR, 505 Park Avenue, New York, New York 10022.

Copyright 1967 by Science & Mechanics Publishing Co.

Service shop tips

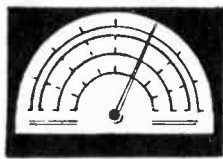

Meter Protection

I would like to install a Lafayette Meter Guard or an International Rectifier MP-100 meter protection rectifier to my VOM. Are they really effective? How should I install one?

—G. D., Montreal, Que.

Yes, they protect the meter from excessive voltage drop across the meter movement and from reversed polarity voltage. The meter protectors usually are furnished with installation instructions. Protectors are not all the same and installation procedures may differ.

What is It?

What transistor can I substitute for a TIX-882?

—F. T., Ronan, Mont.

We couldn't find it listed in Datadex or in industrial catalogs. You can probably get the exact type or substitute from Allied Electronics, the industrial division of Allied Radio, at 100 North Western Avenue in Chicago by mail order. Often special-batch or experimental transistors are given company numbers—the manufacturer will often provide exact data or indicate a suitable replacement.

Quick as a Wink

I have an early transistorized hi-fi amplifier whose power supply has burned out a couple of times. I would like to modify it to use an electronic filter in place of electrolytic capacitors. Diagrams of the original power supply circuit and the proposed new circuit are enclosed. Do you think the new circuit will be better?

—A. L. W., Ithaca, N. Y.

No. If the power supply burns out because of a shorted power

transistor in the amplifier (usual cause) or because of electrolytic capacitor failure, the new circuit will be subject to the same hazards. Cure: put a fuse in the collector or emitter circuit of each power transistor—one in the power supply would have to have a much higher rating and the transistor could go before the fuse. Also bear in mind that semiconductor diodes should normally have a series resistor in the circuit to limit current surges into the input filter capacitor. Current surges can burn out diodes faster than a wink.

Seek and Ye Shall Find

I can't find a GE C6B silicon controlled rectifier in any of my catalogs. I am convinced you bought the last one. If you know where I can get one, please let me know.

—H. K., Eau Claire, Wis.

You will find it listed on page 270 of the 1967 Allied Catalog, priced at \$2.07. You can order one by mail from Allied Radio Corp., 100 N. Western Ave., Chicago, Ill. 60680.

Not Worth It

Can you give me a diagram of an amplifier for increasing the power of my 15-watt transmitter to 20 watts?

—F. M. B., Spring City, Tenn.

It is not worth building an amplifier to increase power only one-third. You'll get out almost as well with 15 watts as with 20. That small a change can often be accomplished by increasing the B-plus voltage 25 to 30% above what the manufacturer designed into the unit, assuming, of course, that the circuit will accept such modification.

One-Transistor FM Set

Can you give me a circuit for a one or two transistor FM tuner?

—B. B., Rocky Ford, Colo.

Here's a diagram of a superregenerative receiver which will receive AM or FM. For coils, pick them from the J. W. Miller catalog which any, on-his-toes parts distributor should have or should be able to order for you. Unless you are very close to an FM station, don't expect great results. And, make sure you use a transistor that will oscillate at VHF.

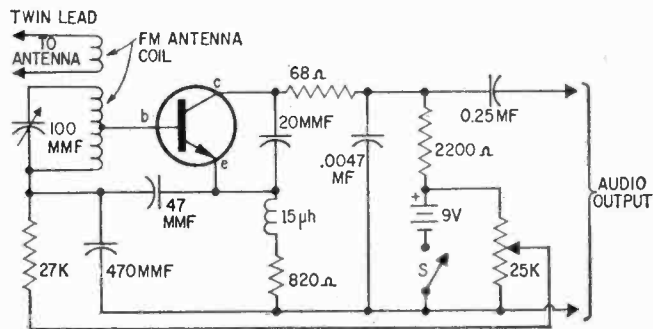

service shop tips

6-Volt Recharger

Can I recharge a 6-volt ignition battery using a charger as shown in the schematic?

—D. T., Mayo, Fla.

Yes. To get the full scoop, write for a copy of *Using the Secondary Capacity of Primary Cells* from Dynamic Instrument Corp., 115 E. Bethpage Road, Plainview, New York.

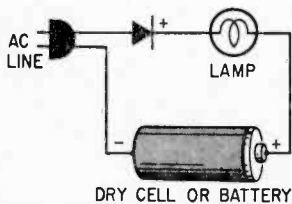

BCB Skywire

I would like to know how to improve the BCB reception of a Knight-kit Star Roamer receiver. I am in a dorm and a long wire is impossible.

—W. H. P., Troy, N. Y.

Try using the power line as an antenna as shown in the diagram. Reverse AC plug to see which side gives best reception. Don't overlook the signal pickup abilities of bed springs, and combination storm-screen windows (or other metal frame windows) or the rain downspout and gutter. For safety, use the capacitor when making the connections—someone else might get the same idea.

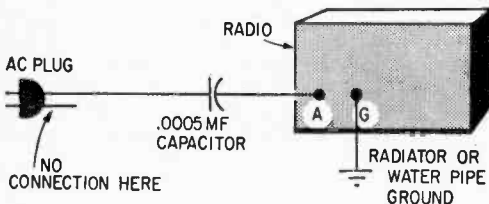

Never The Twain Shall Meet

Is it feasible to modify a standard portable FM radio for receiving the 30-50 MHz or 150-174 MHz band?

—P. H., Ukiah, Calif.

While you could modify the front end (mixer, oscillator, RF), the IF amplifier would be too broad and you would have trouble separating land mobile stations, several of which would fit into the 200 kHz (kc) or wider band pass of the receiver.

Converting Converter

How can I convert a UHF TV tuner so I can use it with a 150-174 MHz (mc) band receiver for tuning in 450-470 MHz band mobile stations?

—K. W., Chicago, Ill.

Add a slight amount of capacitance (a few mmf) across the oscillator tank until it tunes down below 470 MHz. To connect its output to your receiver, use a 300-to-75-ohm matching transformer (balun) as shown in the diagram. The impedance match into your receiver won't be perfect, but it is suitable for such an inadequate set-up.

You will also need an outdoor (rooftop) 450-470 MHz band antenna. You can get one from Mark Products in Skokie near you. The UHF balun is also required, as shown. Here again, you may have some mismatch since most communications antennas are 50 ohms.

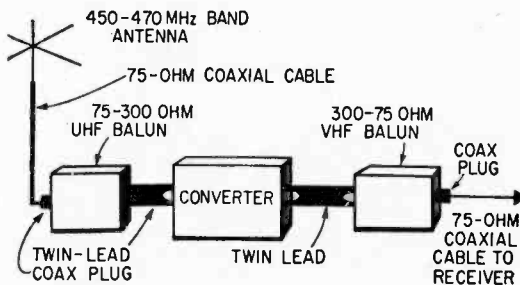

Adding Antenna Input

I am a beginning AM-BCB listener and would like to know how to set up an outside antenna for my receiver.

—J. W., Cortland, N. Y.

If your radio has a loop antenna or loopstick, replace it with an antenna coil (RF transformer) such as Miller A-320-A as shown in the diagram and connect an antenna and ground to the primary of the transformer. Add the connections shown in heavy lines. Adjust the core of the new coil for best reception.

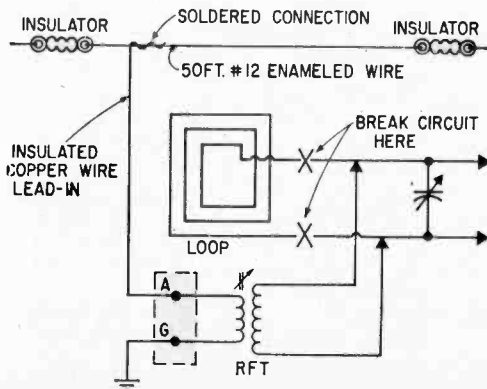

Amateur General

I am interested in getting an amateur general class license. Where can I get a book that will tell me all I need to know to pass the examination?

—M. W., Arlington, Va.

Go to a radio parts store and get a copy of "General Class Amateur License Handbook" which is published by Howard W. Sams & Co., Inc. If your radio distributor doesn't have it, any book store can order it for you. Also, send a letter to John Huntoon, W1LVQ, American Radio Relay League, 225 Main St., Newington, Conn. 06111 asking of help.

It'll Cost Ya!

My CB radio has crystal holders for only six channels. Can you give me a circuit for modifying it so I can transmit and receive on all 23 channels by turning a dial instead of having to change crystals?

—R. R., Medford, Mass.

You can use the channel selector switch used in the Knight-kit Safari III connected as shown

in the diagram. Order spare part No. 437-157 from Allied Radio Corp., 100 N. Western Ave., Chicago, Ill. 60680. You will have to add crystals and crystal sockets.

Before you put the rig on the air, have all the channel frequencies measured by a licensed operator at a two-way mobile radio shop. Otherwise, you might operate off frequency and be inviting a citation from the FCC.

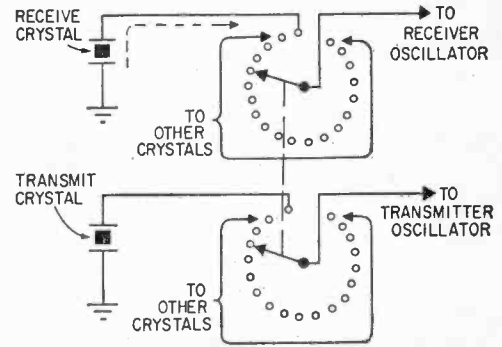

Now...the most enjoyable, most rewarding electronic kit project of your life



a Schober Electronic Organ!

The Schober Organ Corporation
43 West 61st Street, New York, N. Y. 10023

HAD YOUR FILL of amplifier kits, receiver kits, meter kits, all the conventional kits? Then go to work on the biggest, most fascinating kit of them all—and end up with a finer musical instrument than you could buy for twice the price. The Schober Theatre Organ at left, for example, plus Schober's self-teaching music courses, lets you *participate* in music, not just listen to it. This is one electronic project the wife and kids will encourage—because it's for them, too! It contains the best components available—thousands of them—plus the kind of unmistakable, step-by-step instructions you've dreamed of and Schober is famous for.

The Theatre Organ (*left*) costs just \$1550 if you use your own amplifier and speaker system, and you can pay as you build to spread out the cost. There are three other Schober Organ models, too, starting at \$645. Each one includes every bit and piece you need, including a magnificent walnut console—unless you want to build your own woodwork and save even more. And each model has the kind of pipelike tonal variety you don't often find in electronic organs. The free Schober color catalog has lots of pictures and data; and for 25¢ we'll send you 72 pages of schematics and tech specs so you can see just what you're buying.

FREE INFORMATION AND DEMONSTRATION RECORDING
Send today for your free copy of Schober's 16-page, full color booklet, plus 7" free recording.

The Schober Organ Corp., Dept. RT-1
43 West 61st Street, New York, N. Y. 10023

- Please send me Schober Organ Catalog and free 7-inch "sample" record.
- Enclosed please find \$1.00 for 12-inch L.P. record of Schober Organ music.
- Enclosed is 25¢ for schematics and tech specs.

NAME
ADDRESS
CITY..... STATE..... ZIP NO.....

service shop tips

Shame, Shame

I would like to know where I can buy or order Amperite delay relays and at what prices.
—L. E. M., Chicago, Ill.

At Allied Radio, 100 N. Western Ave., on your town's west side.

Fixed Antenna for Portable FM

How can I connect an external antenna to my portable FM-broadcast receiver which has a monopole telescoping antenna?

—F. M. B., Latham, N. Y.

Get a 75 to 300-ohm antenna matching transformer (FM/TV), such as the JFD MT-50, which has screw terminals, and connect it as shown in the diagram. Use short leads with alligator clips to connect to the monopole antenna (not extended) and the receiver chassis.

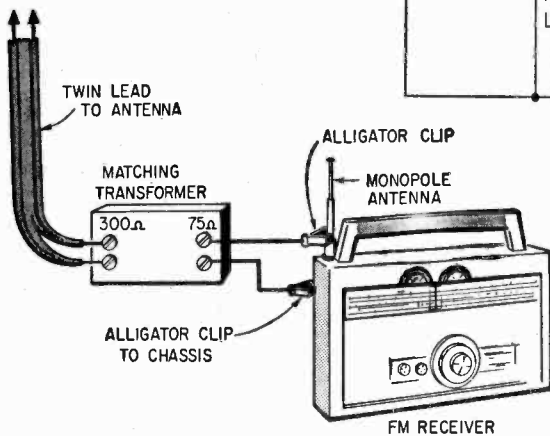

interchangeable. Look through back issues for intercom diagrams and match the transistors you have with those specified.

BCI from Thermostat

The aquarium heater in our house causes annoying noise in my radio receiver as the thermostat cuts in and out. I have tried many different commercial static eliminators, but none have worked. What should I do?

—M. E. B., Jacksonville, Ill.

Your best bet is to get a new heater with built-in radio interference filters.

Low Down On Converter

Are converters practical for receiving low frequencies below 100 kHz (kc), say as low as 15 kHz? Are there any receivers that tune these frequencies?

—W. R., Waukegan, Ill.

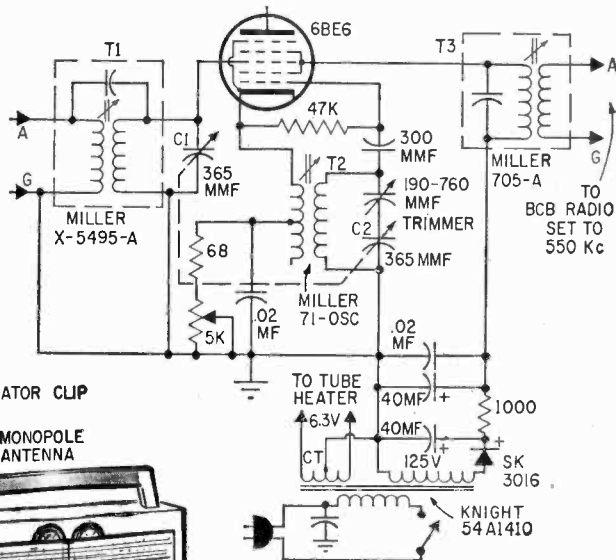

Yes, but there are some problems since you will be converting frequencies up instead of down. There's nothing much to hear below 140 kHz except standard-frequency signals of value to laboratories. The diagram shows a circuit of a converter for 140-425 kHz. Your parts store should be able to order the coils for you. You may not be able to gang tuning capacitors C1 and C2. Set your BCB radio to about 550 kHz, tune in stations with C2 and adjust C1 for best reception. If your receiver doesn't have antenna connections, place the converter so that T3 (a ferrite loop antenna) is close to the radio's loop antenna.

Seek and Ye Shall Find!

I have a number of transistors and diodes of various types in some quantity. Is it possible to make an intercom using them?

—S. B., Key West, Fla.

Get a copy of "Datadex" (DT-2) on transistors from a radio parts store or from IRC, 401 North Broad Street, Philadelphia, Penn. It lists the equivalents of the transistors you identified by type number in your letter. There are jillions of transistor types, many of them

Makino Limiter for CB

I have two CB sets that are very noisy. A schematic is enclosed. Please tell me how to modify the circuit to employ a Makino limiter circuit.

—P. L. McG., Knoxville, Tenn.

The first diagram shows the present detector, noise limiter and AVC circuits in your set. All three share the three diodes of a 6BJ7 tube. The second diagram shows the modified circuit. Note that one of the diodes is now used as an AVC rectifier. The tube-socket terminal numbers are noted on the diagram.

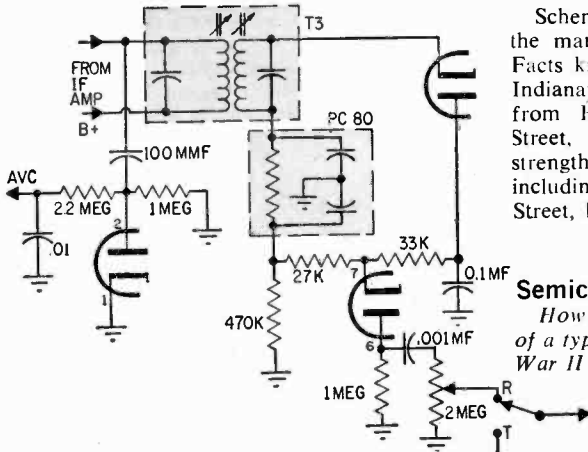
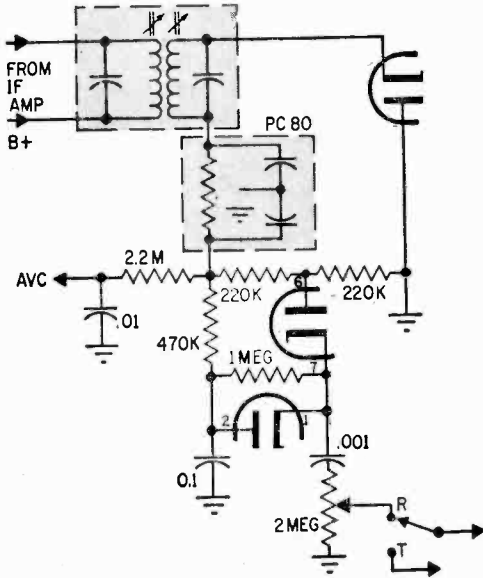

Try, Try Again

I repair radio and TV sets as a hobby and have come across a trouble that has stumped me. Recently, I replaced its 50C5 tube and the radio played well for a few days. Then, the two

local stations started to sound distorted and a noise like static is heard. All other stations sound normal. I cleaned the tuning capacitor and tested all the tubes and then replaced all of them except the 50C5. There was no improvement. Got any ideas?

—T. I., Dalton, Mass.

Sounds like front-end overloading. It could be caused by inadequate AVC voltage. Check the capacitors in the AVC circuit (could be leaky or shorted), also the resistors. Also, it could be the incorrect bias on the 50C5.

Color-TV Problem

On our color TV set, the colors all run into the white. One side of a face is sometimes purple and the other side green. The convergence has been checked. We are about 100 miles from a station. Could our 11-year-old antenna cause this? Would a new antenna help?

—F. R. M., Ponce City, Okla.

Sounds familiar. Happens in New York, too —within sight of the TV-station antennas on top of the Empire State Building. For good color TV, get the best antenna you can (most directive and highest gain) and use low-loss coaxial cable instead of twin-lead as the transmission line. After the new antenna system has been installed, get a competent service technician to adjust and degauss your set.

Service Library

I need books and schematics of Sears, Admiral and other TV sets, also a field-strength meter. I have put up 100 antennas for my customers and TV signals are weak here.

—J. A. W., East Stroudsburg, Penn.

Schematics of most TV sets are available from the manufacturers and in the form of Photo Facts kits from Howard W. Sams & Co., Inc., Indianapolis 6, Indiana, and in schematic books from Hayden/Rider/Ahrens, 116 West 14th Street, New York 11, New York. TV field-strength meters are made by several companies including Jerrold Corporation, 401 Walnut Street, Philadelphia, Pennsylvania.

Semiconductors for Type 80

How can I use semiconductor diodes instead of a type 80 rectifier tube used in the pre-World War II power transformer radios?

—W. W. (Address not given)

Whether you want to replace an 80, a 5Z3, or a more modern 5Y3, the best way to do it is make a plug-in adapter from the base of a defective tube. Use diodes with a 150-ma, 600-volt piv (prv) rating. (To replace other rectifier tubes you may need 750 ma diodes—with two or more connected in series to handle the piv

service shop tips

rating of the tube.) Generally the silicon diodes will give a higher B-plus voltage than the tube did so the voltage drop across the resistor (that you *must* connect in series with the diodes) won't be noticed. Without the resistor, very-high current surges into the input filter capacitor can "pop" those diodes the first time you turn the power on. You don't have this with a tube-type rectifier. The filament warm-up time lets current increase slowly with no surge.

If you wire the diodes directly to the rectifier-tube socket, run the pigtail leads down through the tube-pin holes in the wafer sockets to prevent someone from plugging a tube into the socket and upsetting things.

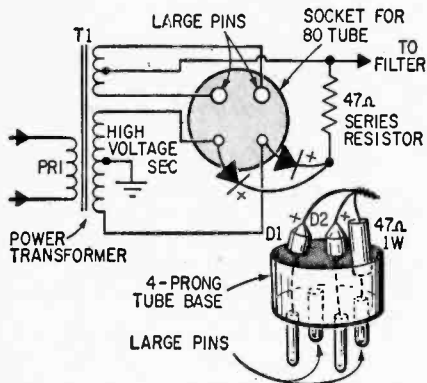

Tone It Down

How can I add bass and treble controls to my amplifier?

—C. R. C., Woodstock, Ill.

According to the diagram you sent (partially reproduced here), you already have a treble

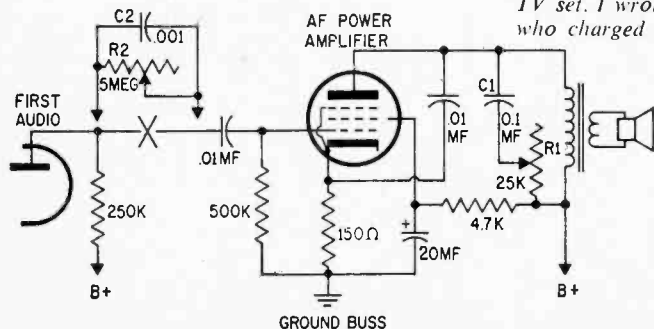

control (R1). To add a bass control, break the circuit at "X" and add R2 and C2. Try a 5-meg-ohm potentiometer for R2 and a 1000-picofarad capacitor for C2. Try various values for C2 until you get the desired effect.

What Luck!

In my 14-transistor radio, two of the transistors are connected as diodes. Two other PNP transistors have their collectors and emitters connected together. An example is Q2 in the enclosed diagram. I don't understand how Q2 works. Do you know?

—H. P. W., Wichita Falls, Tex.

You're lucky your set actually has all 14 of its transistors connected. Some gyp manufacturers install transistors that aren't even connected into the circuit so they can claim to have an umpteen transistor radio. There must be an error in the diagram you sent us. The collector and emitter of Q2 should not be connected together. Otherwise, Q2 would not function as the local oscillator which it apparently is.

It's a Problem!

How can I convert a UHF television converter to receive the 216-470 MHz band between the VHF and UHF television bands?

—W. B. T., Atlantic City, N. J.

It might be tricky. If it uses coils, increase their inductance. If it uses tuned lines, lengthen them. You should have a VHF-UHF signal generator, which is expensive, for making the adjustments. There's not much to listen to in that range except in the 450-470 MHz (mc) land mobile band where you might hear a taxi dispatcher. It won't work with a conventional (intercarrier sound) TV set unless you add an oscillator to simulate the video RF carrier. (To produce the sound, both the audio RF carrier and video RF carrier must be present.)

TVI from Receiver

When I tune my shortwave receiver past certain frequencies, interference is caused to my TV set. I wrote the manufacturer of the TV set who charged me \$5 for a device which didn't work. How can I stop the interference?

—R. K., Morton Grove, Ill.

The local oscillator of your shortwave set is probably radiating and is being picked up by the TV antenna or IF amplifier. Your shortwave receiver may be inadequately shielded. Move it and its antenna as far away as possible from the TV set and its antenna. ■



The THINKING MAN'S ANSWER TO TV SERVICING

By Robert F. Lewis

TVs can be a cinch to service, but only if you first take careful aim and mix a little method with your madness

■ When it comes to do-it-yourself TV servicing, do you use the “shotgun” method to locate bad tubes? If you’re the average, non-technical, television set owner you probably do, since you couldn’t be expected to know exactly where the target is. What do I mean by the “shotgun” method? Well, here’s how it works:

Your TV set is acting up. So you pull out all or most of the tubes, cart them down to the corner drug store or supermarket, and run them through the do-it-yourself tube checker. You find two or three that show a “bad” or “questionable” reading, so you buy some new ones. When you get home and plug in the new tubes, you may find that you still haven’t cured the sickness. Even if you have, there’s a good chance you’ve replaced some tubes needlessly, since a questionable tube-checker reading doesn’t always indicate a bad tube.

First Step Forward. What can you do to avoid this unnecessary expense? Here are some tips that may save you considerable cash and frustration the next time you tackle the one-eyed monster!

First, unless you have some technical knowledge of television, you shouldn’t ordinarily attempt to carry servicing beyond the tube-changing point. You don’t have to be

an engineer or technician just to change a TV tube, but it does help to have a little familiarity with the inner workings of your set. This isn’t as complicated as you might think; you can learn enough about it in the time it will take you to read this article.

Second, most TV receivers have, pasted somewhere inside the cabinet, a tube location diagram. This gives you a wealth of information; it tells you the type and location of each tube, plus the kind of job it does.

Now, with these two pieces of knowledge at hand, you should be able to direct most of your troubleshooting efforts to smaller sections of your set—to zero in on the exact tube or tubes ruining your viewing. You shouldn’t have to use the expensive scatter-gun approach.

Before we go any further, let’s agree to concern ourselves only with black-and-white TV. Unless you have considerable servicing know-how, it’s best to leave most color TV repairs, even tube changing, to a competent repairman, since many of the circuits in color TV sets require critical adjustment for proper color rendition.

A Little Theory. What is a television picture composed of? If you look at any newspaper photograph—called a “halftone” illustration—through a magnifying glass you will

see that it is made up of rows of fine black dots. In the light areas of the picture the dots are very small, leaving considerable white space between. In the darker areas the black dots are larger, leaving less white space. At a distance your eye sees the whole mass as a complete picture, since it can't distinguish between the individual dots.

Now, turn on your TV set and tune it to some channel where no picture is being transmitted. Look closely at the screen. See how the picture is made up of a series of horizontal lines of light? These lines are actually traced on the screen by a rapidly moving spot of light produced when a sweeping electron beam inside the picture tube strikes the screen. The spot travels across the screen, starting at the upper left-hand corner and working down to the lower right-hand corner, in the manner shown in Fig. 1. For

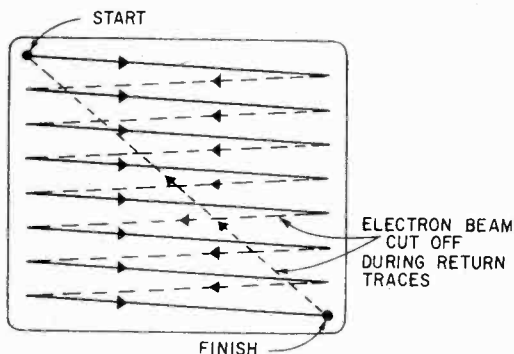

Fig. 1. Simplified diagram of TV raster does not show complicated interlacing.

the sake of clarity, we have shown the lines much farther apart than they really are on your TV screen. There are actually over 400 of these lines on the screen.

When the spot gets to the lower right-hand corner, it returns almost instantly to the starting point and repeats the trace. This screen "painting" process is repeated at such a rapid rate that your eye cannot detect the movement of the spot, but sees the screen as though it were continuously lighted. The technical name for the lighted screen is the "raster." Keep this term in mind. We'll use it again later.

At the Studio. Now, if we were to break up the horizontal lines into dots of varying brightness, we would have all of the neces-

TV TROUBLESHOOTING CHART

Symptom	Possible Source of Trouble
No picture, sound or raster	Low-voltage rectifier. Filament burned out in one tube of series-connected string. Fuse.
Picture dim, does not fill screen. Sound weak.	Low-voltage rectifier.
Picture and sound weak or dead. Raster OK.	RF amplifier, oscillator, mixer, video IF amplifier, video amplifier.
Picture dead or has low contrast. Raster OK. Sound may be dead in some sets.	Video amplifier.
No sound. Picture OK.	Sound IF amplifiers, ratio detector, audio amplifiers.
Picture does not fill screen vertically. Cannot be corrected with height control.	Vertical oscillator and vertical output, low-voltage rectifier.
Picture rolls vertically. Cannot be stabilized with vertical hold control.	Vertical oscillator, sync separator, sync amplifier.
Picture does not fill screen horizontally. May also be dim.	Horizontal oscillator, horizontal output, damper, low-voltage rectifier.
Picture flops over sideways and rolls vertically.	Sync separator, sync amplifier.
Picture flops over sideways. Cannot be stabilized with horizontal hold control.	Horizontal oscillator, sync separator, sync amplifier.
Picture dim but raster fills screen. Sound OK. Sync OK. Cannot be brightened with brightness control. Image sometimes "blooms" around edges when brightness control is turned up.	High voltage rectifier, damper, picture tube.
Picture does not fill screen either horizontally or vertically.	Low-voltage rectifier.
Picture contrast fades up and down, excessively.	AGC, RF and IF amplifier tubes.

sary elements for a picture, as we saw in the newspaper illustration. In practice, this is essentially what is done. The light and dark portions of a TV picture are produced by simply varying the intensity of the electron

beam as it paints the screen. The signals that produce this variation originate in the camera in the TV studio. The image "seen" by the camera is swept by an electron beam in the same manner we have just described for the receiver picture tube. But instead of painting a scene, the camera breaks the image it sees into bits, like the dots in the newspaper illustration. These bits are sent out in sequence by the TV station, received by your TV set, and reassembled on the picture tube screen in exactly the same order and position. To create the illusion of a complete picture, these bits are broken down and reassembled at an incredibly rapid rate, several million per second. Other signals transmitted by the TV station synchronize the picture tube in your set with the studio TV station synchronize the picture tube in your set with the studio TV camera so that both will begin "painting" at exactly the same instant. The third signal transmitted by the station is the sound or "audio" signal. If the picture is in color, additional color-information signals are transmitted. Sounds fantastic, doesn't it?

same as, or similar to, those indicated on our diagram. In some cases you'll notice that a single tube does several jobs, possibly in completely unrelated sections. This is because many tubes contain two or three sets of elements in one envelope, a space-saving trick.

Sound, picture, and synchronizing signals from the TV station arrive via your receiving antenna and are all processed in the *RF amplifier, mixer, oscillator, and video IF amplifier* tubes.

These signals continue on to the *video detector and video amplifier* tubes where they are further processed. The picture signal is extracted and applied to the picture tube where it controls the variations between dark and light on the screen.

The synchronizing signals are routed through the *sync amplifier and sync separator* tubes, then applied as locking signals to the *vertical oscillator and horizontal oscillator* tubes.

The sound signal is separated at this point and passed through the *sound IF amplifiers,*

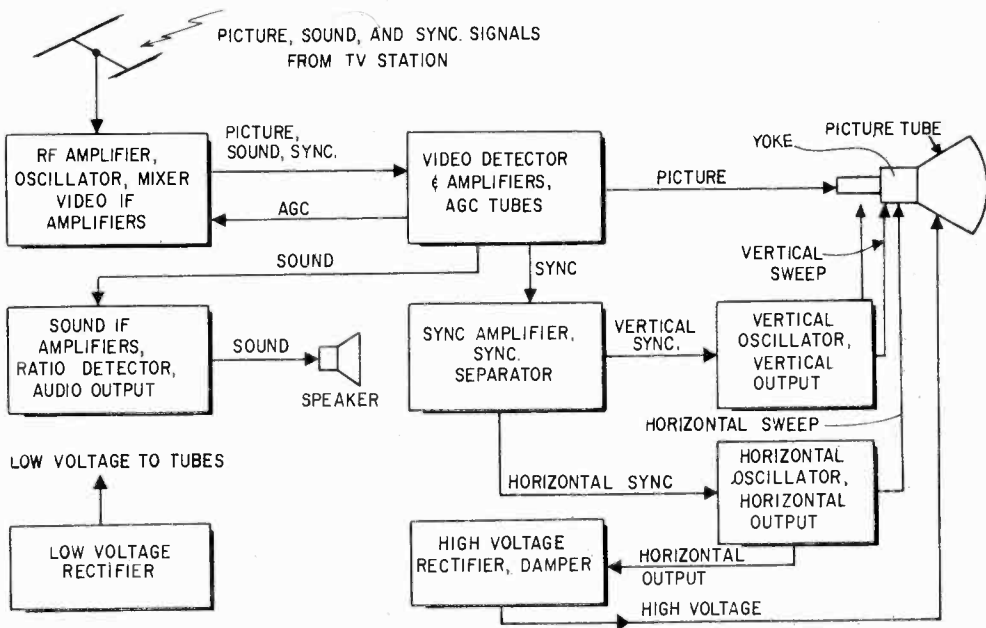

Fig. 2. Block diagram of TV circuitry is just about the same for all black & white TV sets.

Around the Block. Now, let's take a look into your TV set. Fig. 2 is a simplified block diagram showing the electronic-tube circuits in a typical black-and-white television set. Let's trace the routing of signals through the diagram. As we do this, refer to the tube location diagram in your own set and see if you can find tubes whose functions are the

ratio detector, and audio amplifier or output tubes, then to the loudspeaker.

Another circuit is the AGC or automatic gain control.

The purpose of the AGC tubes is to minimize fading or fluctuations in the picture contrast that may occur when the incoming TV signals vary in intensity. This often hap-

pens when an airplane is flying overhead.

The *vertical oscillator* and *vertical output* tubes control the vertical sweeping of the electron beam in the picture tube. The horizontal sweeping of the beam is controlled by the *horizontal oscillator* and *horizontal output* tubes.

Every picture tube requires a potential of somewhere between 10,000 and 25,000 volts for its operation. This voltage is generated by the *horizontal oscillator*, *horizontal output*, *high voltage rectifier*, and *horizontal damper* tubes. Very little *current* is developed in most high-voltage systems, so it is generally not dangerous to human life; although if you get a jolt from it, it can be startling and uncomfortable—something like getting a shock from an automobile ignition system.

Finally, the *low voltage rectifier* tube supplies all of the lower voltages to the other tubes in your TV set. In the more recent models, a metallic rectifier is used instead of a tube for this purpose.

Zeroing In. Now that you have more than a nodding acquaintance with your TV set, how can you use this newly gained knowledge? Here's an example, a typical troubleshooting situation:

Let's assume that your picture tube screen is brilliantly lighted and that the raster completely fills the screen. Yet there is no sound and no picture. Looking at our block diagram, you can see that the sections that are common to both picture and sound are the ones that include the *RF amplifier*, *mixer*, *oscillator*, *video IF amplifiers*, *video detector*, and *video amplifier* tubes. So you proceed to check these tubes. Forget the others.

Another common TV complaint is vertical "rolling." The image keeps slipping up or down and cannot be stabilized by adjusting the *vertical hold* control. This symptom indicates that your TV set is not synchronized with the camera at the TV station. It is likely to be caused by a faulty *vertical oscillator tube*, or perhaps by a weak *sync amplifier* or *sync separator*. This narrows your search down to two or three tubes; no need to use the "shotgun" system. Our troubleshooting chart directs you to source of still more symptoms in a malfunctioning set.

Picture Tubes. The TV picture tube gen-

erally gives long life if properly installed and adjusted. Loss of electron emission due to old age is a common problem, however, and is indicated by a gradual dimming of the picture that cannot be restored by adjusting the brightness control or by replacing small tubes. The life of a picture tube that shows aging can often be extended by installing a *picture tube brightener*. However, you should not use a brightener on a perfectly good picture tube, since it increases the heater voltage and may reduce the life of the tube or even burn it out.

If you are going to use a picture tube brightener, first determine if your TV set has *series* or *parallel* connected tubes; then buy the corresponding type of brightener. If all of the tubes in your set (except the high voltage rectifier and picture tube) begin with the number 6 or 12, the tubes are probably parallel connected. If the tube designations start with various numbers other than 6 or 12, series connection is most probable.

Pulling Tubes. Here are a few tips to keep in mind when replacing the small tubes in your TV set.

1. Be sure to turn off the receiver and disconnect the power plug before working inside the cabinet.
2. Wait for the tubes to cool enough to handle before trying to pull them out.
3. Discharge the stored high voltage from the picture tube by connecting one end of a *well-insulated* wire to the TV set chassis and touching the other end of the wire to the high-voltage terminal which connects to the side of the picture tube envelope. You'll probably have to slip the wire under the edge of the rubber insulator to make contact with the high-voltage terminal.
4. When you replace a tube, be sure that the new one is the correct type number as marked on the tube location diagram. Don't switch tubes around just because they look alike, unless they have the same number.
5. Be careful not to bend the pins on miniature tubes. Be sure the pins are straight before attempting to insert tubes in sockets.
6. If you doubt some of the readings you get on a do-it-yourself tube tester, recheck the tubes on another machine before investing in a new tube.

If your diagnosis fails to turn up a faulty tube because the trouble lies deeper, then you'd better turn the job over to your serviceman. However, if you're successful, you can sit back and bask in the glow of your TV set and the cash savings you've made! ■

The MOST from your B & W TV

By H.B. Morris



■ You can bet an old fuse that TV sets have controls for mighty good reasons. Knobs in front let you scrimmage with the image until it agrees with your idea of a good picture. Further back are non-operating controls that need occasional touch-up. They'll shore up sagging tubes or aging components that can warp and shrink the picture.

Adjust controls and you'll delay the day the set needs tube replacement, maybe chassis repair. Best of all, controls keep the picture a pleasure to view, even on old sets. Why see fuzzy cowpokes wearing 40-gallon hats ride off into the black margin of a setting picture tube? Grip the pots, twist the tabs, and you'll be in Marlboro country!

You may argue that adjusting front controls is a matter of personal taste. True, but let's consider tricks that might improve your dialing technique—and reception. For though the main channel selector is nearly foolproof, other controls aren't so precise. Here's why.

Fine-Tuning. Anyone knows this one is turned for best picture and sound. Trouble is that best settings for sound and picture often don't agree, especially in weaker signal areas. Fine tuning must be a compromise. And the quickest way to find the best point is hunting for what's affectionately called "worms" in the picture.

Play with fine tuning and you'll see that turning it in one direction causes the

turning it in one direction causes the picture to slowly fade. But turn it in the opposite direction and the screen should break into a mass of wriggles. Best adjustment of fine-tuning occurs if you back off *slightly* until the worms *just* disappear.

The slithery pattern is actually the sound carrier spilling into the picture. Use the tuning technique just described, and you can perfectly balance sound and picture as intended by the circuit designer. This method lets you capture good picture detail in the shortest possible time.

Vertical Hold. If the picture's not rolling, you say, that's proof the vertical hold control is properly adjusted (see Fig. 1). Sorry about that. Even if Flipper seems as stable as a snoozing Moby Dick, the control may not be perfectly adjusted. Thing is, TV pictures operate on *interlaced scanning*. It means the picture beam swings down and illuminates the screen on every other line (1, 3, 5, etc.). Then it repeats the scan for the missing (2, 4, 6) lines. This is a crafty trick to reduce flicker in the picture. But to do the job well, the set's vertical oscillator must perfectly lock to the station's sync signals. And that's where tuning technique can make or break it.

If you adjust the control carelessly the picture may stand still—but the sync signal may have to work hard to keep it there. The result could be "jitter" or "pairing."

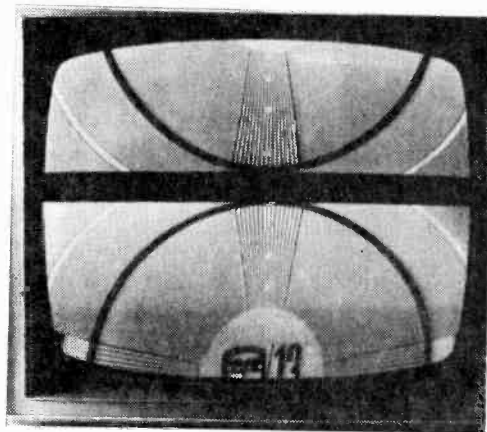

Fig. 1. Even if picture isn't rolling as above, vertical hold control may not be set properly.

Fine scanning lines on the screen bounce or run together, which, of course, steals sharpness from the image. You can avoid it by setting the vertical hold with this simple technique.

Turn the control until the picture starts rolling in a *downward* direction. Next, turn the knob *slowly* the opposite way until the image moves *upward*. Soon the frames begin to snap into place. When the picture's finally locked in, remove your hand from the knob. Always stop tuning on an *upward* roll of the picture. A close look at the screen should reveal well-separated, motionless scanning lines.

Horizontal Hold. There's much leeway in this adjustment, since TV horizontal circuits are semiautomatic. A grossly misadjusted control will produce slashing diagonal bars (Fig. 2). As the knob approaches correct setting, the number of bars diminishes

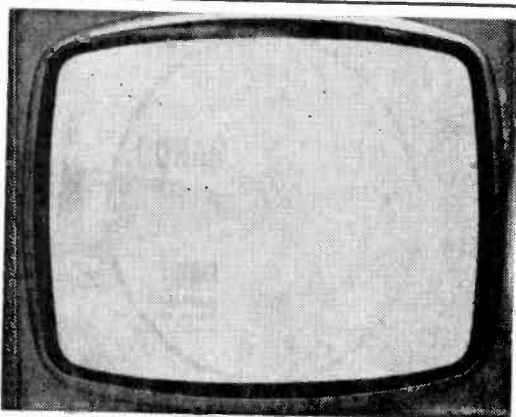

Fig. 4. Setting brightness control too high will cause a picture detail to wash out.

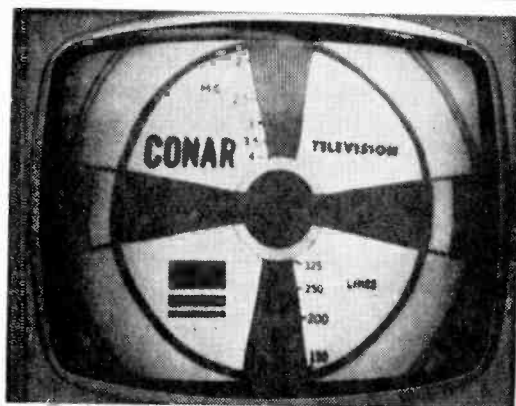

Fig. 5. Excessive contrast results in loss of picture detail and subtler gray shadings.

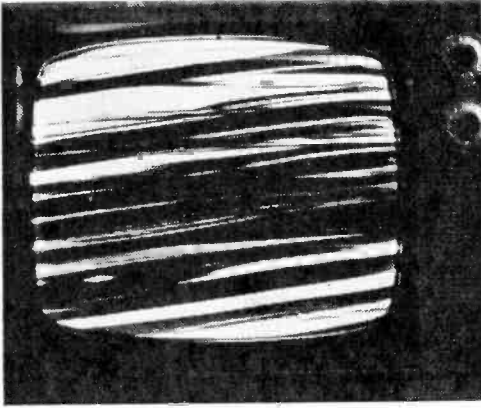

Fig. 2. Horizontal hold should be set so picture is stable after channel is changed.

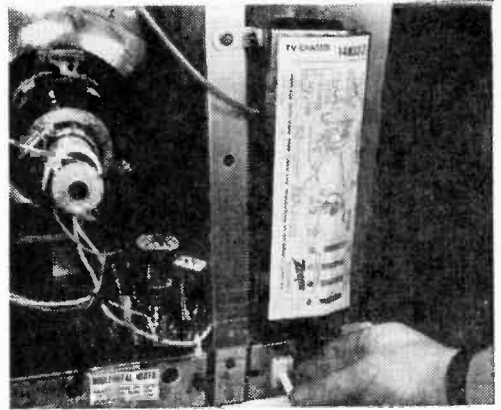

Fig. 3. Many late-model sets have horizontal-hold control located on the back of cabinet.

until the picture stands up straight. Yet there is margin for error.

First, be sure the setting is stable, quickly checked by flipping among all receivable channels. There should be no loss of horizontal sync—even temporarily—each time the main channel selector lands on a new channel. Check the picture for any distortion or whitish areas, especially at the left. This control may be located at the rear in some sets (see Fig. 3).

Contrast and Brightness. Little can be said about these controls since their effects are well known and settings mostly a matter of preference. Excessive brightness (Fig. 4) washes out the picture and may cause a few diagonal white lines to appear at the top of the screen. They're eliminated by slightly reducing brightness or increasing contrast. Pour on excessive contrast (Fig. 5), and the picture assumes a grainy texture of strong

blacks and whites with loss of detail. Snowy reception is usually aggravated by too much contrast.

On some sets, excessive contrast might cause "sync clipping," which could cause a wavy unstable image (Fig. 6). If it happens when contrast is weak, chances are the set needs a tube or repair in the IF or front-end stages. The range of contrast is often determined by the set's AGC circuit (automatic gain control). If one is provided in your set, check its adjustment, as described in a later section.

That takes care of up-front, user-operated controls that let you trim picture and sound for daily viewing. For the next group of adjustments—non-operating controls that need only occasional attention—you'll have to penetrate more deeply into the set. Some are accessible through holes; others require removal of the back cover (Fig. 7).

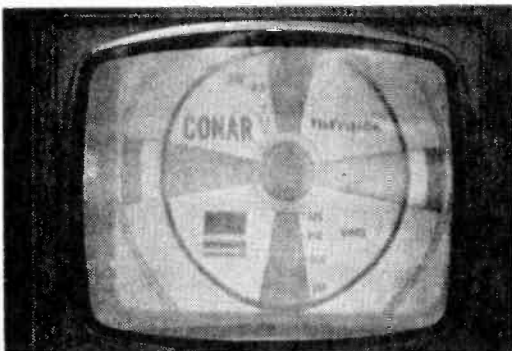

Fig. 6. Unstable picture with low contrast may indicate need for AGC control adjustment.

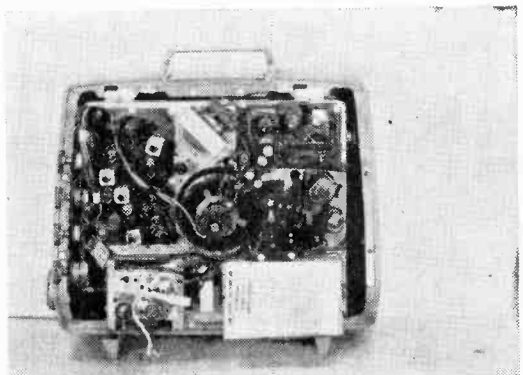

Fig. 7. Back of set may have to be removed for access to little-used controls.

If you can't locate a certain control there are several possibilities. One is that the manufacturer has completely omitted it (the horizontal width control is a casualty in some recent sets). Two, the control may not be readily apparent. An example is focus. Many sets eliminate a control and use adjustable metal strips on the picture-tube pins instead.

Since this and other controls may be difficult to find, you'll save time if you first obtain the service folder on your model. But before you touch anything inside the set, consider these precautions while you let the set warm up for 15 minutes.

The Shocking Truth. High voltages required to operate the various parts of a television receiver present an extremely dangerous shock hazard. To protect the user from dangerous shocks, most TV sets have an interlock switch or special line cord attached to the back cover. When the back cover is removed, the interlock switch opens or the line cord is disconnected, opening the power supply circuit. A caution label containing this information is affixed to the back cover of most TV sets.

To gain access to such controls as the ion trap magnet, deflection yoke, and on many TV sets, the positioning and focus controls, you must remove the back cover. This means that you will either have to detach the line cord from the back cover, or use a separate

line cord (cheater cord) to connect the set to the power outlet. On sets using an interlock switch, you will also have to secure the switch in the closed position, possibly with masking or friction tape.

In making adjustments you will be working in close quarters, relatively near parts having high voltage. The following precautions should be observed when making adjustments inside the cabinet while the set is operating. (1) Do not adjust controls inside your set while standing on a concrete floor. (2) Make sure that there are no metal objects or wiring nearby through which you might make accidental contact to a good electrical ground. (3) Always keep one of your hands in your pocket when making your adjustments. This will prevent you from making a contact that could produce an unpleasant or dangerous shock. (4) Avoid contact with all parts having high voltage, especially the picture tube anode, or, in the case of a metal shell, the tube. (5) In general, stay way from all tubes to avoid burns. A burn caused by a hot tube, or an electrical shock, can result in cuts or bruises from striking other parts as your hand is withdrawn from the source of danger. (6) Use only moderate pressure to adjust any of the controls on the neck of the picture tube. Undue pressure or a jar can break the glass envelope causing the picture tube to explode.

If you follow these safety rules and use sound and careful judgment, you can safely and correctly adjust your television set.

Test Patterns. Many TV stations transmit a test pattern for short periods before

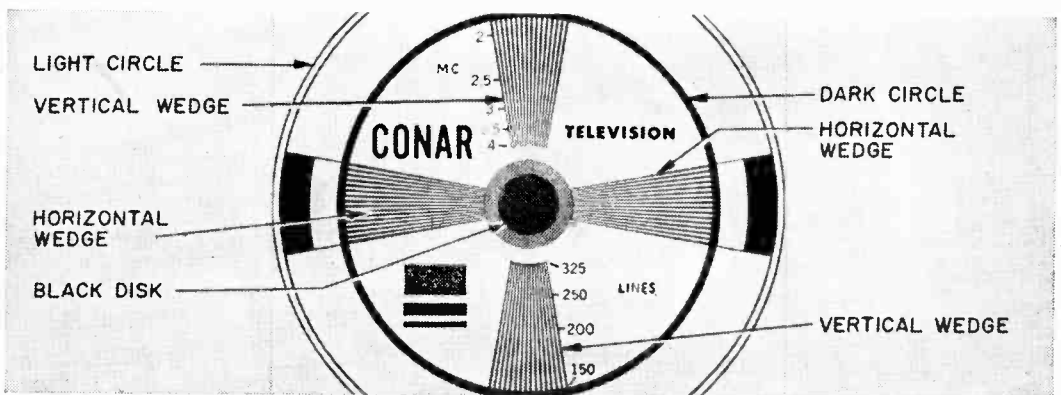

Fig. 8. Test pattern transmitted by stations before regular programs aids adjustments.

and after their regularly scheduled programs. Test patterns are a valuable servicing aid in making rapid checks of the performance and adjustment of a TV receiver. If no test pattern is available at the time you adjust your set, you can use the actual picture to check the adjustment of the various controls.

A mirror placed in front of the set will enable you to observe the picture on the screen while you make adjustments from the rear of the set. Fig. 8 shows the appearance of a typical test pattern. Whenever the controls on any TV receiver are correctly adjusted, the test pattern should have the same general appearance as shown.

The elements of the test pattern are labeled in Fig. 8 and should conform to the following specifications. The light circle should appear just inside the edges of the mask when the horizontal and vertical size controls and the centering controls are properly adjusted. The dark circle and the edge of the black disc are perfectly round when the horizontal and vertical linearity controls are properly adjusted. Wedges are vertical and wedges are horizontal when the deflection yoke is properly positioned. The lines in the wedges are sharp and distinct when the focus control and ion trap magnet are properly adjusted. The concentric circles are of different shades from light gray to black, when the brightness, contrast, and AGC controls are properly adjusted. Let's consider how to adjust each control.

AGC (Automatic Gain Control). The AGC control when properly adjusted enables you to tune to different channels having various signal strengths without requiring

you to readjust the contrast or volume controls each time you change channels. If the AGC control is improperly adjusted, a strong signal will cause the picture to have excessive contrast, and a hum will be heard in the audio. Often, the picture becomes completely distorted or negative.

Fig. 9 shows this condition. To adjust the AGC control, tune the receiver to the strongest channel in the area and rotate the AGC control clockwise until you notice excessive picture contrast, buzzing sound, and pulling or tearing at the top of the picture. Then rotate the AGC control counterclockwise until the picture becomes normal once more. This is done for the strongest channel in your area.

Focus Control. There are three types of focus controls in use on TV sets. One type uses a magnet located on the neck of the picture tube. This can be adjusted by a shaft

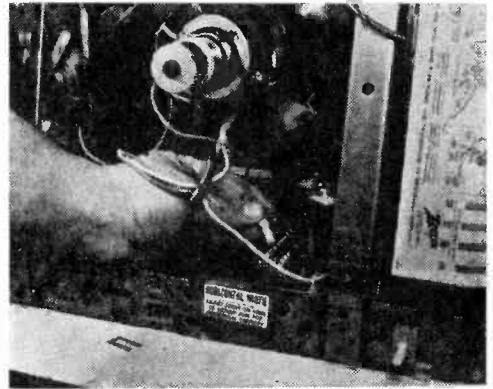

Fig. 10. One type of focusing arrangement is adjusted simply by selecting proper tap.



Fig. 9. Improper setting of AGC control causes variety of symptoms like one above.

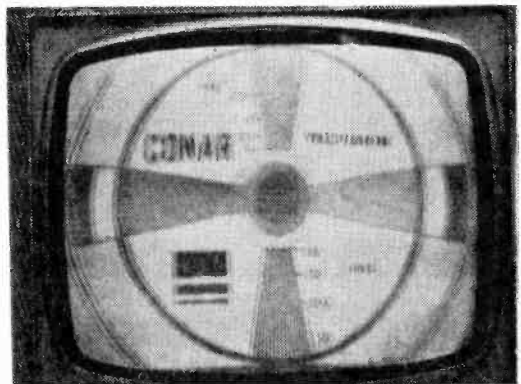

Fig. 11. Typical indication on screen when picture tube requires focusing adjustment.

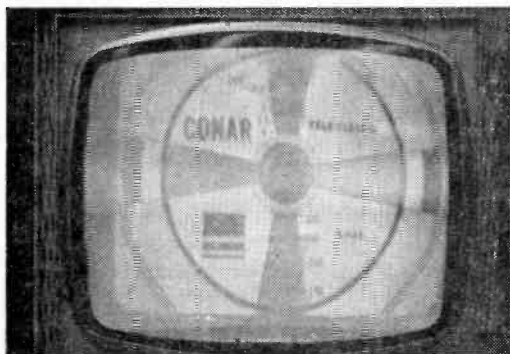

Fig. 12. Sets with sync stability control will require adjustment of this control when the condition in the photo is observed.

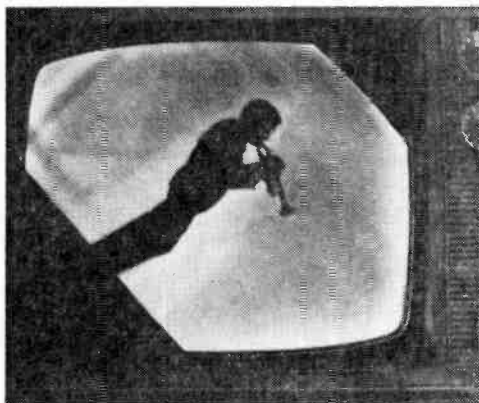

Fig. 13. Tilted picture occurs when yoke has rotated on picture tube neck, usually as a result of set being sharply jarred.

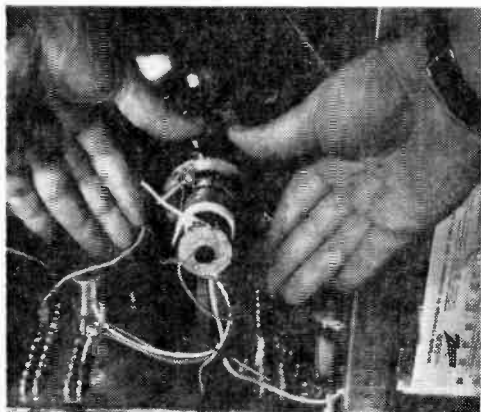

Fig. 14. To adjust yoke, loosen clamp screw, hold only insulated part, and rotate carefully.

extending from the back of the set, or you may find it necessary to adjust several screws to correctly position the focusing magnet.

A second type of focus control uses a control to electromagnetically focus the beam.

A third type focusing arrangement uses a series of taps or terminal connections to which the focusing electrode is attached to give the best possible focus (see Fig. 10). Fig. 11 shows the effect of an improperly adjusted focus control. Note the lack of definition in the image as compared with the normal test pattern. The focus control should be adjusted to give the sharpest, clearest picture possible.

Sync Stability Control. Fig. 12 shows the effect on the picture of improper adjustment of the sync stability control. Note the bending of the image in the top of the pattern. This control adjusts a noise rejection circuit so that noise in the picture signal will not upset the sync. To properly adjust the sync stability control, observe the picture on the strongest local station with the AGC control properly set, and rotate the sync stability control counterclockwise until the picture bends at the top. Then back off the adjustment until the bending stops.

Buzz Control. Some late model, quality TV receivers, such as the Conar Custom 70, have a buzz control. This control is adjusted to the position at which hum, or buzz, in the sound is minimum.

Correct adjustment of the fine tuning control, the AGC, and Contrast Controls also help eliminate buzz. These controls should be checked first for proper adjustment, then the buzz control should be adjusted for minimum buzz.

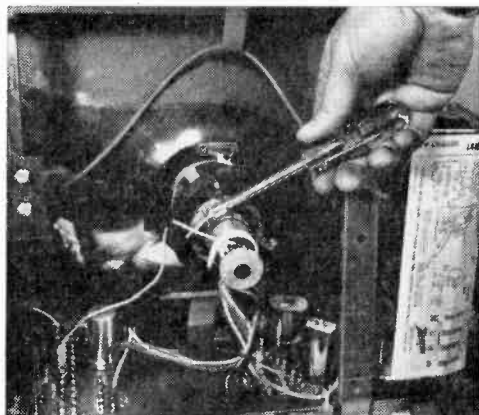

Fig. 15. When yoke is positioned, tighten clamp screw, being careful not to over-tighten.

Ion Trap Magnet. To adjust the ion trap magnet, move it back and forth along the neck of the picture tube, rotating it slightly at the same time, until you obtain maximum brightness on the face of the picture tube. Next, adjust the focus and positioning controls (described below) and re-adjust the ion trap magnet. You may have to adjust the ion trap magnet so that the brightness is decreased slightly in order to improve the focus.

Many modern TV sets do not use an ion trap magnet. The phosphorous coating on the face of the picture tube is backed with a thin layer of aluminum. Electrons readily pass through this aluminum layer to strike the phosphor coated screen, but the heavier ions are blocked by the aluminum layer. The aluminum layer also reflects the light back to the viewing side of the screen that normally would radiate into the back of the picture tube. This type tube both dispenses with the ion trap magnet and will give a brighter picture than the type which does not have the aluminum layer.

Deflection Yoke. The deflection yoke is located on the neck of the picture tube. Its purpose is to produce the varying magnetic field necessary to deflect the electron beam vertically and horizontally to produce the scanning raster on the screen of the picture tube. If the yoke is not correctly positioned, a tilted picture will result (see Fig. 13). To correct a tilted picture, first make certain the yoke is positioned as far forward on the neck of the picture tube as the bell will allow, and then rotate the yoke (Fig. 14) until the picture is level. When the yoke is in properly positioned, it should be secured

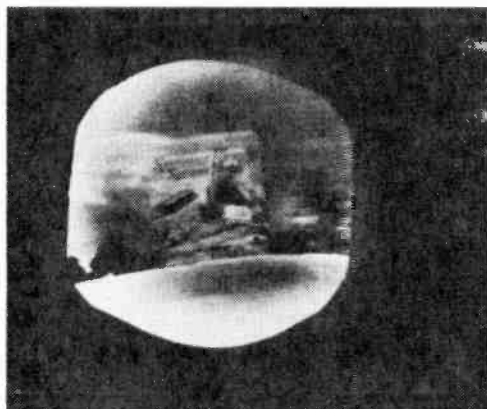

Fig. 16. If picture doesn't fill screen, yoke isn't properly seated against picture tube.

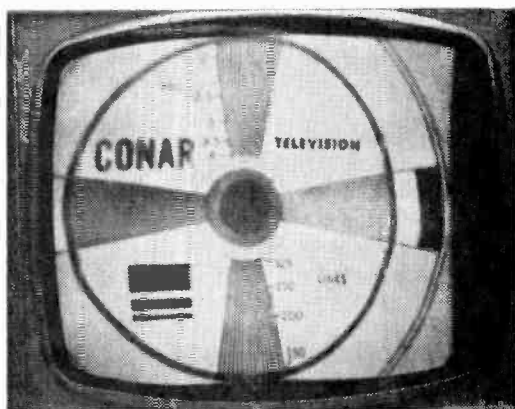

Fig. 17. Unfilled screen on either side indicates that horizontal centering controls generally are incorrectly set, though problem can also stem from electrical defects in circuits.

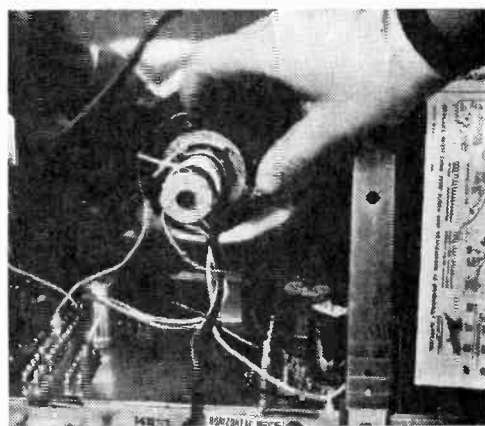

Fig. 18. Magnetic rings on picture tube neck behind yoke are used to center picture. The two tabs are rotated around neck for both correct horizontal and vertical centering.

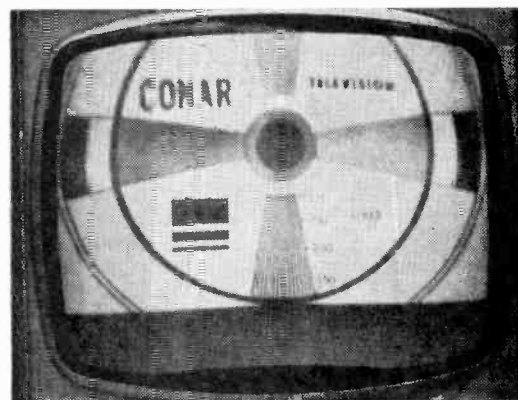

Fig. 19. Incorrect vertical centering in photo above is adjusted as shown in Fig. 18.

in position by a clamp or lock screw (Fig. 15). Note in Fig. 16 that the picture doesn't fill the screen if the yoke isn't against bell or flared part of the picture tube.

Horizontal Centering Control. The effects of misadjustment of the horizontal centering control on the picture may be seen in Fig. 17. To center the picture horizontally, move the metal rings on the yoke cover (see Fig. 18) until the picture assumes the desired position.

Vertical Centering Control. This control is accomplished in a similar manner to horizontal centering. Actually it is necessary to adjust for both vertical and horizontal cen-

tering at the same time. Fig. 19 shows a picture with the vertical centering control out of adjustment.

Horizontal Linearity Control. The horizontal linearity control may be adjusted to change the horizontal radius of the picture from the center to the left or right side. Fig. 20 shows the effect of a misadjusted horizontal linearity control. Note the elongated left side of the picture compared with the right side. To adjust the horizontal linearity control, rotate the shaft until the horizontal radius of the picture from the center to the left side is equal to the radius from the center to the right side. It's often necessary to adjust the horizontal size control along with the horizontal linearity control.

Width (horizontal size and drive) Control. In some instances there are two con-
(Continued on page 100)



Fig. 20. Condition above is corrected by adjustment of both the horizontal linearity control and the width or drive control.

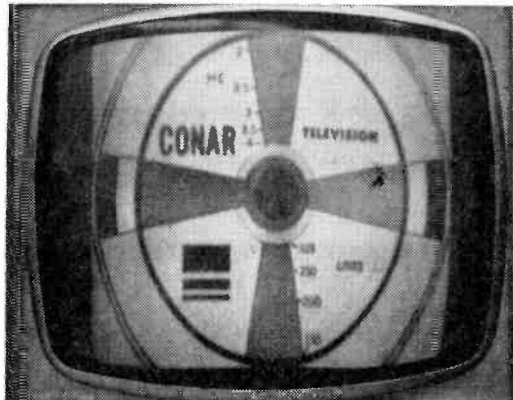

Fig. 21. Picture with insufficient width to fill screen can be corrected by simply adjusting width control until picture is wide enough.



Fig. 22. Too much horizontal drive causes vertical white line to appear on screen.



Fig. 23. Long skinny people can be cut down to size by adjusting vertical height control.

LOOK BEFORE YOU LISTEN

. . . and let square waves reveal stereo's every stumbling block

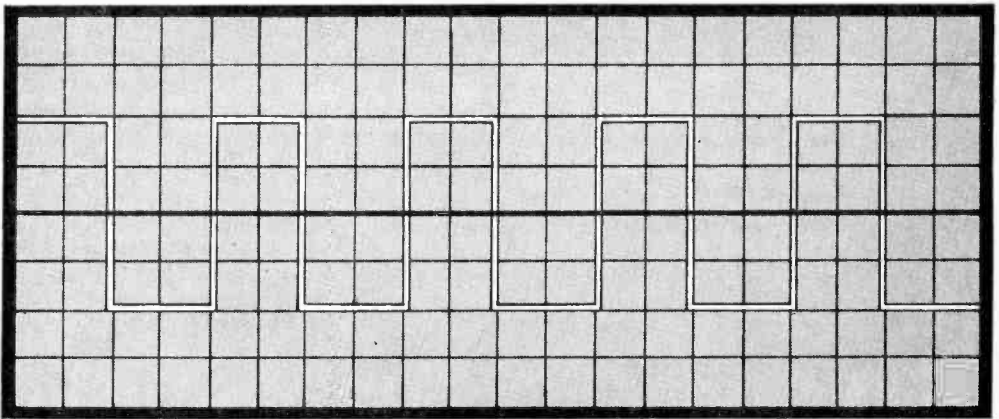

By VERNON SIMMS

Nothing lays bare an audio amplifier faster than a square wave. This lopped-off, stiff-sided test signal acts like it's got a built-in brain. Feed one into a hi-fi set and it'll come out reading "tilt" if the circuit isn't up to snuff. Tinker with a home-brew amplifier and square waves let you see what happens as you beef up bass or meddle with the treble. And as our pictures show, square waves can pinpoint a raft of symptoms that spell trouble in audio equipment.

Old Lang Sine. A conventional way to check out a hi-fi amplifier is using pure tone from an audio oscillator. Viewed on an oscilloscope, the signal appears like the one shown in Fig. 1; a simple sine wave. It's fine for signal tracing an amplifier that's suffered catastrophic failure—from a burned-out resistor or shorted capacitor, for example. But many troubles, like mushy sound, often won't show up. And examining an amplifier's frequency response is a tedious job with sine waves. Many tones must be fed in, then a graph plotted to reveal how

the amplifier functions on each frequency. Even then many troubles fail to materialize.

Sine in the Square. But lash together a number of sine waves and the picture changes. It's possible to mix a brew of pure tones, each on a different frequency, and come up with a handy composite. That's the square wave. A single square wave may contain up to 30 different frequencies. Square waves are fat signals that ram within their shape a huge amount of frequency information. Let's see how they're born.

In Fig. 2(a) is shown the combining of two regular sine waves. One is the fundamental which we'll assume is a mid-range tone of 1000 Hz. Superimposed on it (dotted line) is a second tone exactly three times higher in frequency. It's the third harmonic on 3000 Hz. As the two sine waves mix, they cancel or reinforce each other at different points. For example, where both waves fall on the positive side of the base line, voltages add; but they buck each other when polarity is opposite. This produces the re-

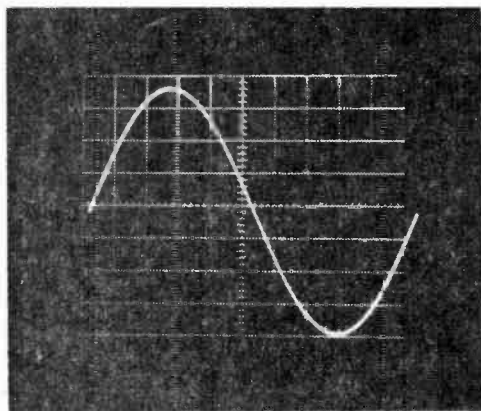

Fig. 1. A sine wave, as seen on oscilloscope screen, represents pure tone at single frequency. Harmonics make wave appear square.

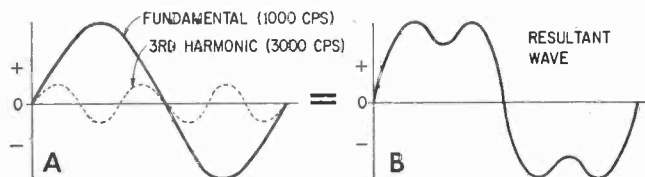
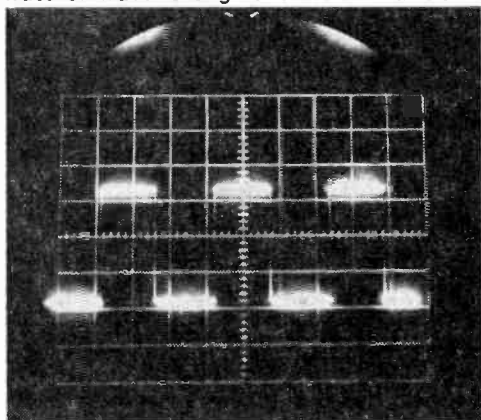

Fig. 2. In A at left, two sine waves are combined; resultant wave is shown in B. By adding more harmonics, squaring can be increased for desired shape.

Fig. 3. Square waves on oscilloscope are at frequency of about 1000 Hz. Look closely; these are square waves, though horizontal trace of wave is brighter than vertical trace.



sultant shown in Fig. 2 (b); a double-humped wave that contains frequency information of both 1 and 3 kHz, the original sine waves. That resultant, however, is not yet a square wave.

By piling on more sine waves, the resultant begins to acquire steeper sides and a

flatter top. Soon it becomes a true square, like the actual scope photo in Fig. 3. This square wave contains harmonics as high as thirty times the fundamental (1000 Hz). One requirement for producing square waves is that harmonics must be only odd-numbered ones; 1, 3, 5, 7, etc. Otherwise the shape will not be square, which is a convenient form for audio testing.

For the sake of comparison, we've shown a sine wave of 1000 Hz in Fig. 4. If applied to a speaker it produces a flat, colorless tone since the wave is pure. An equivalent square wave (Fig. 3) sounds rich, almost musical. That's because it contains dozens of harmonics, or overtones.

Clipped or Triggered. The source of square waves is an audio oscillator. Although simple instruments produce only sine waves, many recent models, like Heathkit used here, include square-wave output. Principle in some models is simply to take a sine wave and severely clip its positive and

negative peaks. The result is a square wave with desired harmonics. A slicker system in some audio oscillators is a trigger arrangement. Here a sine wave is used only to trip an electronic switch on and off. The result is a sharply angular square wave.

The Basic Test. If the square wave sounds like a complex signal, you're right. But that's also the reason it makes audio testing so easy. Since a square wave wraps so much information into one waveform, it applies a number of simultaneous tests to an amplifier. By observing on a scope how the amplifier treats the wave, you're given illustrated clues to what's wrong.

Another valuable feature of square-wave testing is that signals more closely resemble those of music. The smooth sine wave doesn't sock the amplifier, like a sudden cymbal crash or hefty drum beat. The steep-sided square wave does. Thus it yields information on how the amplifier treats transient, at random, signals.

Setting Up. The items needed for checking audio equipment with square waves are shown in Fig. 5. The signal source is the audio oscillator, at left, which feeds the in-

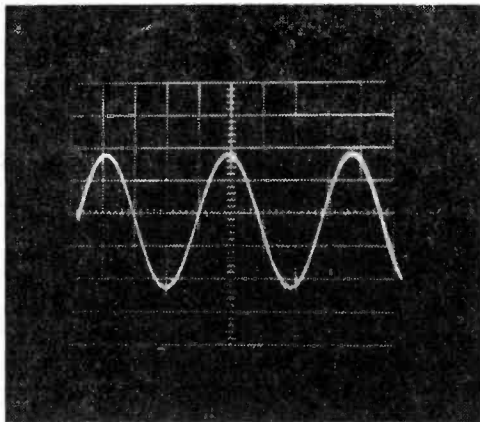

Fig. 4. Sine waves at 1000 Hz are shown here for comparison with square waves in Fig. 3. Note that square waves are not just clipped.

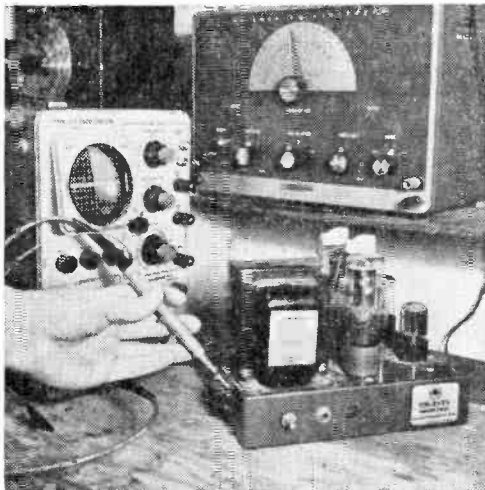
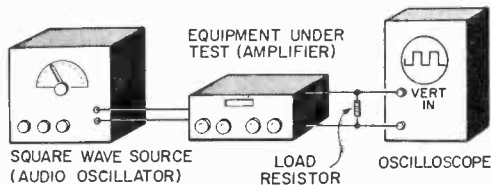

Fig. 6. Heathkit Model 1G-82 Sine-Square Generator and Tektronix 317 Oscilloscope being used to check output of hi-fi amplifier.

Fig. 5. Pictorial of test setup for square wave testing shows load resistor connected. Always set bass and treble controls in "flat" position.



put of the amplifier under test. Instead of the usual speaker at the amplifier output, a load resistor is connected. (Its resistance can be, say, 8 ohms to agree with the amplifier output impedance. Power rating of the resistor should be sufficient to handle wattage output of the amplifier.) Using a load resistor eliminates false readings that might be introduced by voltages reflected back from a speaker voice coil.

To observe the waveform, an oscilloscope is connected across the load resistor. The scope need not be a lab type, but should be able to handle frequencies within the audio range, and somewhat higher. It's possible, when using high square wave frequencies, for some scopes to distort the wave shape. This should be checked by first feeding the wave from the audio oscillator directly into the scope. The scope or audio oscillator manual should provide required adjustments for initial squaring off of the wave, if necessary.

An actual test set-up is seen in Fig. 6. In Fig. 7 a load resistor is shown being connected across the output of the amplifier in place of a speaker. And in Fig. 8 a scope probe is being connected across the load resistor.

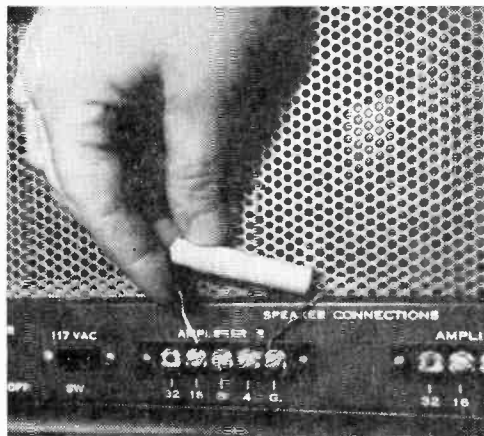

Fig. 7. A load resistor is placed across output terminals of amplifier, then scope is connected. Leads from amplifier go to vertical input.

Feeding in Signals. There are some precautions to observe while testing with square waves. One is that amplifier tone controls must be set to their "flat" position. This is done by adjusting bass and treble controls, usually to their straight up position, as shown in Fig. 9. Otherwise the amplifier might seem to have poor bass response—for example, if the bass control happened to be turned down during the test.

Another factor is determining where to feed in the signal. Usually an "auxiliary" or "tuner" input is a good choice. If you apply the test signal to a phono input, you may see distortion on the scope. This is because phono inputs are equalized; that is, purposefully designed with treble cut and bass boost to

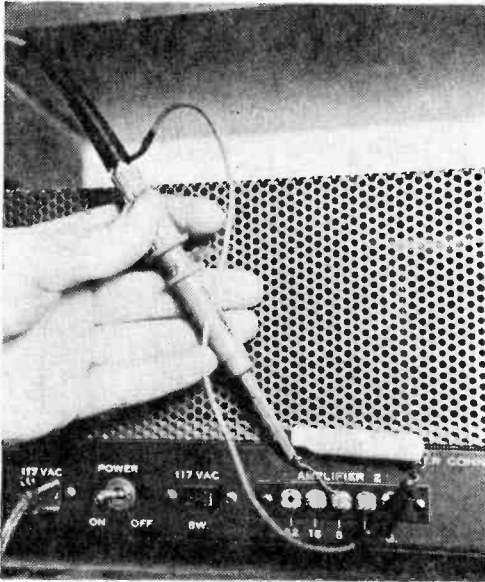

Fig. 8. Oscilloscope probe picks off signal from speaker terminals. Ground lead from probe is connected to ground terminal on amplifier.

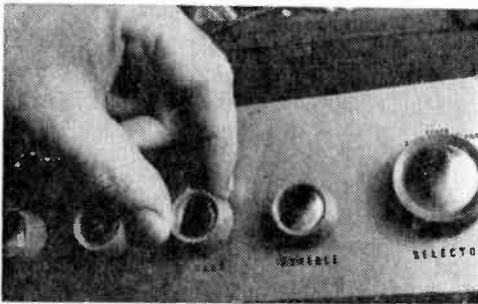

Fig. 9. Set bass and treble controls to flat position before testing. Rotating them during test shows effect of tone controls on wave shape.

offset some frequency juggling introduced during the original disc recording. Phono and mike inputs should be avoided, too, since they provide extremely high amplification and may overload the amplifier. This matter of overload should be considered during any square wave tests. While feeding in test signals, be aware that an overloaded amplifier can also produce square waves due to signal clipping. They may resemble the square-wave signal from the audio oscillator. The problem, however, is usually simple to detect. If the scope picture in Fig. 10 is examined, you'll note that the wave is flat on top

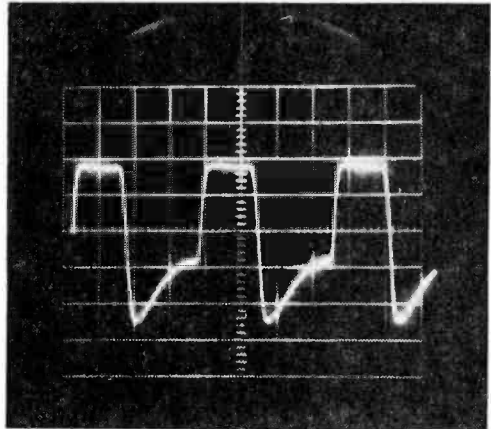

Fig. 10. Lack of symmetry between top and bottom of square wave indicates excessive signal input. Reduce gain of audio oscillator.

and spiked at the bottom. Whenever the square wave does not appear symmetrical on top and bottom, as in Fig. 10, it probably means you're feeding excessive signal to the amplifier. Reduce output from the audio oscillator and the wave should equalize between top and bottom.

Test Frequencies. Just two, possibly three, square wave frequencies can check the complete frequency response of the amplifier. This is because a single square wave frequency contains useful harmonics ranging up to some ten times the fundamental frequency. (We mentioned 30 times earlier, but anything much over ten times is too weak to be of value.) Thus the first test frequency can be at the lower limit of the amplifier's rated frequency response. Let's assume it is 50 Hz. This value is dialed on the audio oscillator. The 50-Hz fundamental square wave will check the amplifier from 50 to 500 Hz. Dial up 500 Hz and the amplifier is put through its paces on the 500 to 5000-Hz portion of the audio spectrum. And a 5000-Hz square wave extends the test beyond the level of audibility. Most high quality amplifiers, in fact, are designed for good performance beyond the range of human hearing and this can be observed during the tests. Now let's interpret the waveforms.

Low-Frequency Response. We'll assume that the audio oscillator is feeding the amplifier with a square wave and the result observed on the scope screen. First major waveform is shown in Fig. 11. It reveals poor low frequency response. This is seen by the slope of the wave across top and bottom. Note that low frequency refers to the

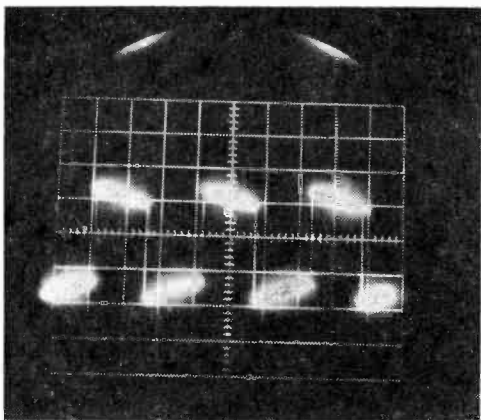

Fig. 11. Slope of square waves across top and bottom indicates amplifier has poor low-frequency response. Text gives probable causes.

lowest square wave frequency being fed to the amplifier. This is the fundamental; the frequency dialed on the oscillator. If that frequency is, say, 500 Hz, nothing below that value will be seen. Thus if you wish to check low-frequency response of a hi-fi amplifier, use a very low square wave frequency, like 20 Hz.

Some causes of poor low frequency response are coupling capacitors of inadequate capacity, defective bypass capacitors, or skimpy output transformer.

High-Frequency Response. The scope photo in Fig. 12 indicates an amplifier that's

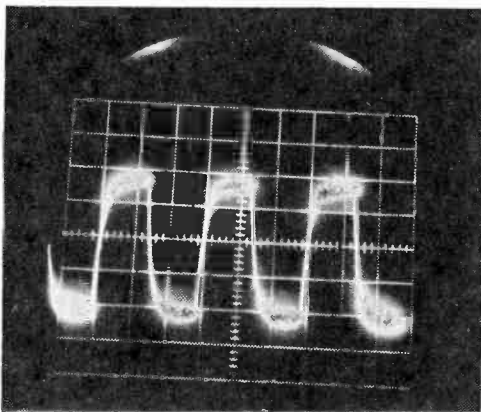

Fig. 12. This is how poor high-frequency response will affect shape of square waves. Leading edges are softened at top and bottom.

losing its high tones. Note how the wave curves near top and bottom. This softening of the normally square shape indicates loss of higher harmonics from the square wave.

High and Low. The square wave in Fig.

13 shows not only an amplifier in sad shape, but points up the versatility of square-wave testing. That trace reveals that frequency response is sagging badly at both high and low ends. Note the rounding at top and bottom.

Overshoot. A small spike forming on the leading edge of the wave, like the one in Fig. 14, denotes *overshoot* in the amplifier. It

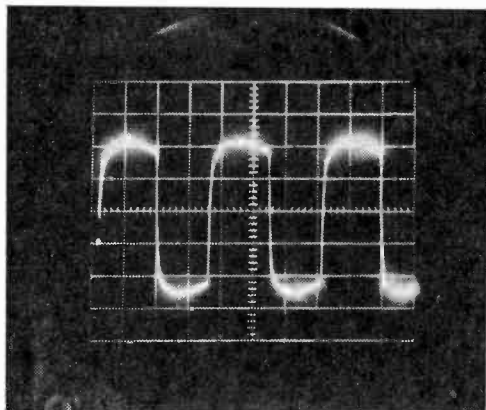

Fig. 13. An amplifier with poor high- and low-frequency response will pass square wave rounded on both leading and trailing edges.

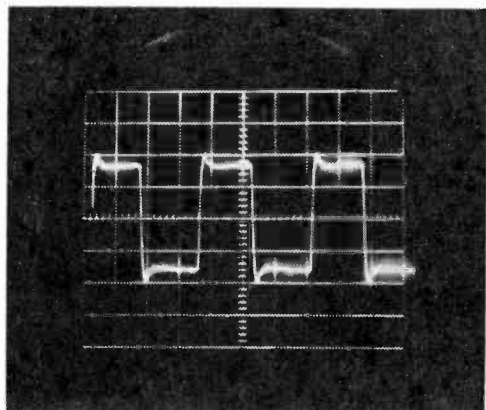

Fig. 14. Small spike on leading edge of square waves indicates excessive high-frequency response that can fuzz sound of transients. means the amplifier is overreacting to the sharp rise of the square wave. In practical terms, an amplifier with overshoot tends to fuzz musical passages of a transient nature; those which occur with fast attack. This problem, actually due to excessive high frequency response, is related to the next waveform.

Ringling. A close look at Fig. 15 reveals a small ripple along the top and bottom of the square wave. This means ringing, a condition where the amplifier is temporarily shocked into an oscillation. Both ringing and

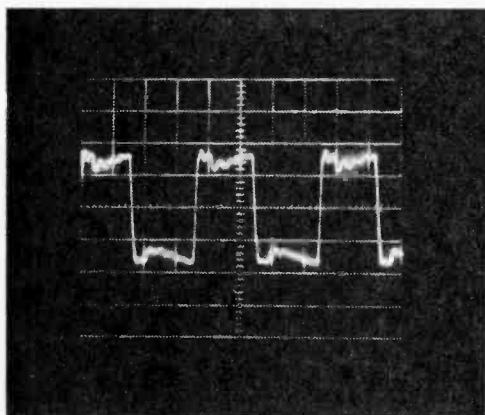
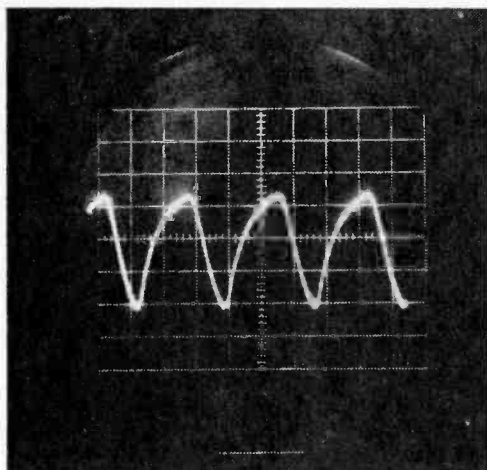

Fig. 15. Ringing is indicated by ripples across top of square wave. Ringing occurs when amplifier has been shocked into near oscillation.

Fig. 16. Almost sawtooth wave form, representing extreme bass response, is obtained when bass control has been cranked full on.



overshoot rob sound of clarity, especially during transients.

Some possible causes in both cases are poor isolation between amplifier circuits (causing undesirable feedback, possibly through adjacent wires) or lack of shielding between circuits.

The waveform in Fig. 16 was obtained by turning the bass control fully up, and treble down. Thus the wave reveals extreme bass response. A trouble that could cause this is

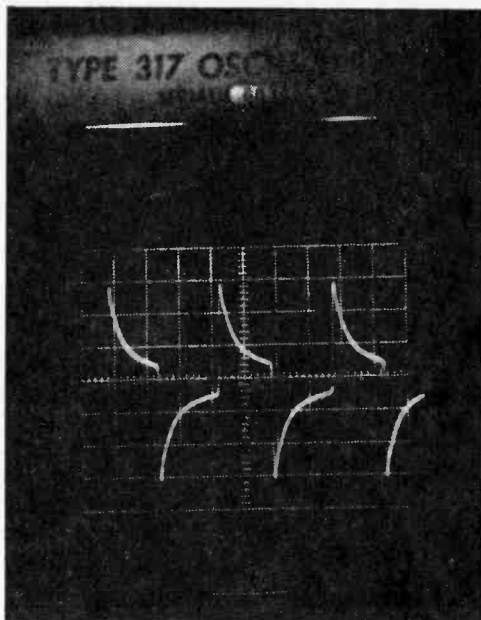
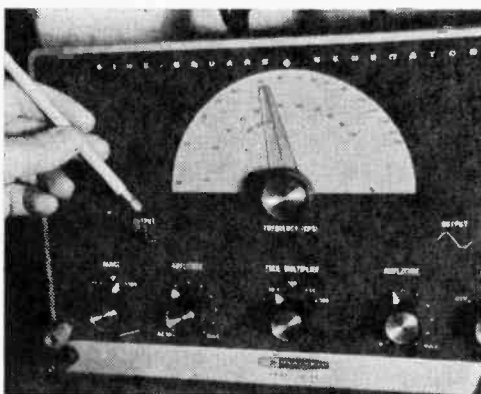

Fig. 17. Audio amplifier with extreme treble response passes square waves which exhibit pronounced attenuation of trailing edges.

On Heathkit 1G-82 Sine-Square Generator front-panel controls are marked with output wave form. Pencil points to square wave.



lack of negative feedback. Fig. 17 reverses the condition, and shows an extreme high-frequency condition.

Whether you're working with hi-fi, PA or any other kind of audio equipment, square waves can speed the job. The ability to put an amplifier through several tests simultaneously makes the square wave a natural for troubleshooting, signal tracing or circuit designing and adjustment. Just watch the scope trace; when it's square—you're there! ■

By Herb Friedman

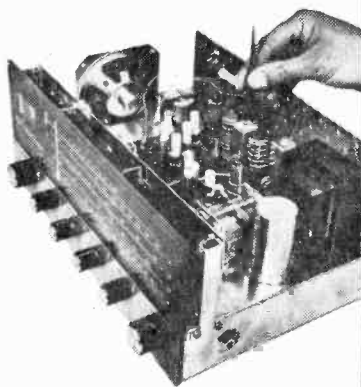

SOUP-UP FOR S-W SETS

Old shortwave receivers seldom die—they just try to fade away

■ From the instant it's first turned on, the performance of even the most expensive shortwave receiver slowly deteriorates. And after a year or so, the SW bands get less and less crowded as weaker stations disappear into the receiver's inherent noise level.

Fortunately, most SW receiver ills are caused by normal aging of components in the tuned circuits. And this in plain terms means that a good alignment job should restore like-new performance. We say *should* rather than *will* because receiver alignment, while not normally difficult, can be somewhat tricky. Get sloppy on just one tuning adjustment and any extra care given the other tuned circuits is worthless.

Good receiver alignment requires the technician to have a single point of focus: *maximum gain*. For with rare exception, maximum sensitivity, selectivity, AGC action, and noise reduction are obtained only when all circuits are tuned for maximum gain. In fact, it's only when the receiver has special high selectivity circuits such as a crystal filter that there is a slight departure from the focus of maximum gain.

Why Alignment? The block diagram of a basic SW receiver (see next page) illustrates the importance of alignment. Strange as it seems, it is the IF amplifier that primarily determines which signal (of many) is received.

For the sake of discussion, let's assume two signals are received by the RF amplifier. One signal is at 2 MHz, the other at 2.01 MHz; the difference (separation) between the two signals is 10 kHz. Since RF amplifiers are normally not sharp tuning devices, both signals will pass through. To be

sure, one will be amplified more than the other, depending on the RF amplifier tuning. But both will still pass through.

Now these two signals are "beat" together in the mixer with the local oscillator which is at, say, 2.455 MHz. The output of the mixer will consist of several frequencies, one of which will be the difference between 2.455 MHz, and 2 MHz, or 455 kHz; the other will be the difference between 2.455 MHz and 2.01 MHz, or 445 kHz. Obviously, any received signals which fall between 2 and 2.01 MHz will now fall between 455 and 445 kHz at the output of the mixer.

If the IF amplifier following the mixer were tuned to 445 kHz the input signal of 2.01 MHz would be the received signal. On the other hand, if the IF amplifier were tuned to 455 kHz it would be the 2 MHz signal that would be received. Now assume the IF were originally tuned to 455 kHz to receive the 2 MHz signal, but that it had somehow

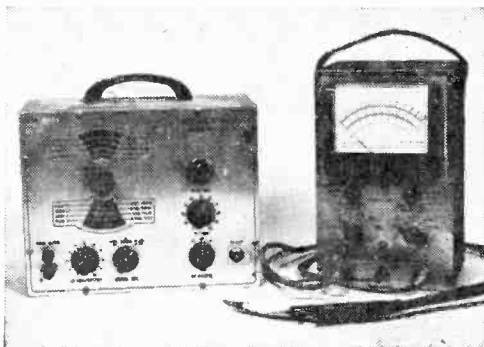

Three things needed to bring back that SW rig are a service-grade signal generator, a VOM or (preferably) VTVM, and a little patience.

drifted (detuned) to 450 kHz. In this case, the IF amplifier would no longer give maximum gain to the 2-MHz signal but to some signal 5 kHz higher than 2 MHz. As you see, the IF amplifier tuning determines which of many signals fed into the RF amplifier gets maximum gain. Therefore, the IF amplifier should be the first step in alignment procedure.

IF Alignment. Somewhere in the receiver's instruction manual is the IF frequency—or frequencies, in the instance of double-conversion receivers—for your particular receiver. If yours is a double-conversion set, the second IF strip should be aligned first. Set the output frequency of a signal generator to the given frequency and connect a VTVM across the AVC bus. (If you don't have a VTVM, connect an AF output meter or a VOM on its AC range across the speaker terminals.) This done, set the meter to its lowest usable range.

Using a 0.001 μ F capacitor (or the value

suggested in the generator or receiver manual) in series with the generator's hot output lead, connect the generator to the input grid of the mixer or the first IF amplifier (whichever is suggested by the receiver manufacturer). Next, employing the lowest possible generator output voltage that will cause the VTVM or VOM pointer to just barely rise, adjust the top and bottom slugs of each IF transformer for maximum meter reading. As the adjustment causes the meter pointer to rise, keep reducing the generator's output to the lowest usable level.

Some manufacturers suggest that alignment be done stage by stage, working back from the grid of the last IF amplifier. However, this procedure generally isn't necessary unless an IF transformer or coil has been replaced and the signal can't be fed through the entire IF amplifier as detailed above.

Since adjustment of one IF slug often upsets the adjustment of the other slug, the top and bottom slug of each transformer should be adjusted in pairs several times until no further improvement can be obtained. Further, if the receiver has a crystal filter that requires special alignment techniques, make certain you follow the manufacturer's

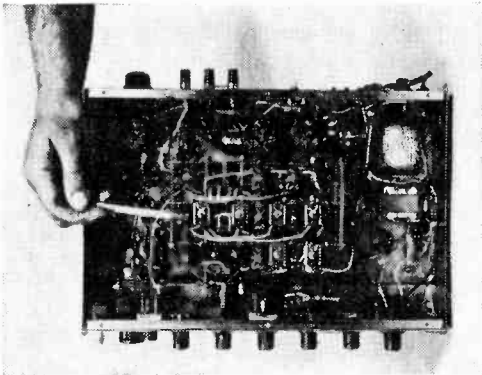

Strip arrangement (see pencil) is common for RF circuits in high-quality receivers.

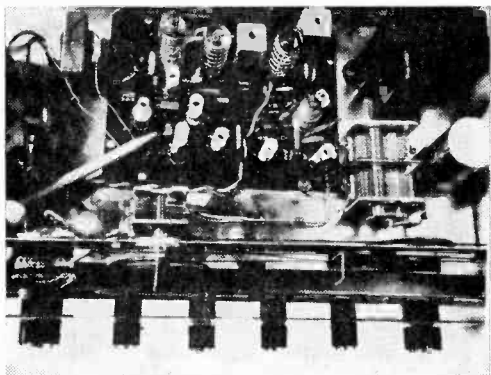

Pencil indicates screw of piston-type trimmer capacitor used in front end of newer SW rigs.

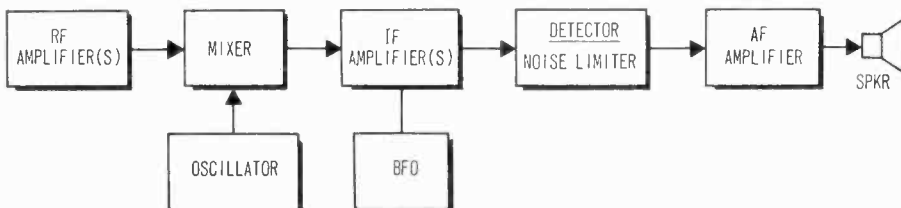

Block diagram shows major sections of typical single-conversion SW receiver.

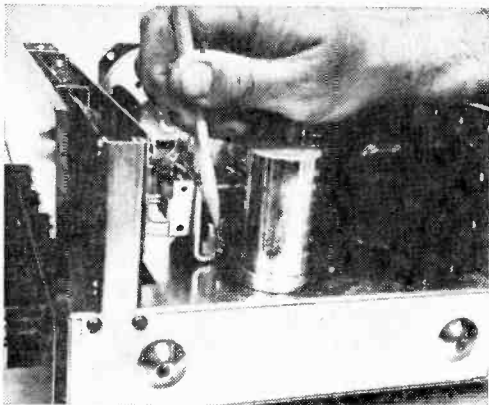

On some receivers, the Broadcast Band trimmer capacitor is located on tuning capacitor.

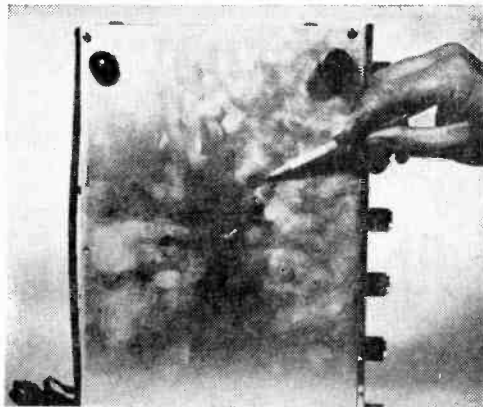

Trimmer capacitors accessible through bottom cover should be aligned with cover in place.

procedure to the letter. A misaligned crystal filter can easily destroy overall receiver performance.

The Front-End. After you're certain the IF amplifier(s) is critically aligned, it's time to do the front-end—the RF amplifier and the oscillator tuning.

The front-end performs three functions. First, it provides amplification of the RF signal, which in turn provides a good signal-to-noise ratio by providing a high-level RF input to the mixer. Second, it sharply discriminates against other RF signals not at the desired frequency, thereby reducing or effectively eliminating image response. (Image signals are signals removed from the desired frequency by a factor of 2X the IF frequency. If the front-end cannot reject the image frequency signals, the image frequency will also be fed through the IF amplifier.) And third, the front-end provides the local oscillator that heterodynes (beats) the RF signal to the IF or first-IF frequency.

Though there are many combinations of front-end alignments that will produce received signals, there is only one alignment that will result in accurate dial calibration. And in fact, front-end (or RF alignment as it's often termed) does two things: it adjusts the local oscillator (if it isn't crystal-controlled) so that the dial corresponds to the frequency being received, and it adjusts the tuning of the RF amplifier so that regardless of the position of the tuning control the RF amplifier provides maximum gain at the received signal frequency.

Band By Band. Each band has its own front-end tuning adjustments. If the receiver has five bands there are five sets of tuning adjustments, though the tuning adjustment

for the Broadcast Band might differ from those for the various SW bands. The most important part of the alignment, next to accurate calibration of the oscillator to the dial calibration is the tracking.

Each tuned circuit in the RF amplifier and the oscillator has at least one coil and one trimmer (some older receivers have two trimmers). The object is to adjust the coil for tracking at the low end of the band and the trimmer capacitor for high end tracking.

Since the adjustment of the coil affects trimmer adjustment, and vice versa, it's necessary to repeat the coil/trimmer adjustments for each band many, many times, until no further adjustment can be obtained. When the oscillator's coil and trimmer adjustments are correct, the dial calibration should be accurate across the entire band, not just at the high and low end. Similarly, the RF amplifier should have maximum gain across the entire band in step with the oscillator tuning.

Test Equipment. As a general rule, most service-grade signal generators are more than adequate for the average SW receiver alignment, and only a VTVM or VOM is needed to complete the test set-up. However, if the technician desires to compare the receiver's re-aligned vs. when-new performance, a calibrated signal generator is required (such generators have meters to directly indicate the RF input level fed to the receiver).

In reality, though, this is really gilding-the-lily; for the calibrated generator offers no effective advantage as far as the actual alignment is concerned. In fact, in meaningful terms, the \$50 service grade generator will do just as good an alignment job as the \$500 calibrated generator. ■

FOREIGN TUBE REPLACEMENT GUIDE

Anyone who's gone past the tuning knob of a foreign-built shortwave receiver has discovered an unexpected twist or three—unorthodox-looking capacitors, metal-film resistors, possibly some outstanding point-to-point wiring. Another distinguishing feature of foreign electronic gear is tube designations, which often bear no resemblance whatever to those current in American circles. The following listing equates foreign tube types with their closest American equivalent. Though slight differences exist in some cases, in general any tube of a pair is directly interchangeable with its mate.

1C1	1R5	CV578	6A8	CV1938	6K6GT	DL91	1S4	KT32	25L6GT
1F3	1T4	CV580	6A8	CV1941	6K7	DL92	3S4	KT63	6F6G
1FD9	1S5	CV581	6C5	CV1943	6K7	DL94	3V4	KT66	6L6GC
1P10	3S4	CV585	6C6	CV1944	6K8	DL95	3Q4	KT71	50L6GT
1P11	3V4	CV587	6Q7G	CV1946	6K8	DM70	1M3	KTW63	6K7
5B250A	807	CV589	6Q7	CV1947	6L6GC	DP61	6AK5	KTW74M	12K7GT
6BK8	6Z67	CV591	6SJ7	CV1950	6L7	DY86	1S2	KTZ63	6K7
6C16	6BL8	CV614	75	CV1956	6N7GT	DY87	1S2A	L63	6J5GT
6D2	6AL5	CV617	80	CV1958	6N7GT	E2157	12AT7	L77	6C4
6F22	6Z67	CV686	0C3	CV1959	50C5	E2163	12AU7A	LZ319	9A8
6F29	6EH7	CV692	0Z4	CV1961	12AU6	E2164	12AX7A	LZ329	9A8
6F30	6EJ7	CV697	12SJ7	CV1969	6SC7	EB34	6H6	M8212	5Z76
6FD12	6DC8	CV717	5R4GYB	CV1970	6SC7	EB91	6AL5	N16	3Q5GT
6G5G	6U5G	CV728	5V4GA	CV1978	6SG7	EB90	6AT6	N17	3S4
6H5	6U5G	CV753	1A3	CV1981	6SK7	EB91	6AV6	N18	3Q4
6L12	6AQ8	CV755	1A5GT	CV1985	6SL7GT	EBF89	6DC8	N19	3V4
6L13	12AX7	CV756	1A5GT	CV1988	6SN7GTB	EC90	6C4	N148	7C5
6M1	6U5G	CV782	1R5	CV1990	6SQ7	EC97	6FY5	N379	15CW5
6P15	6BQ5	CV783	1S4	CV2129	5763	ECC32	6SN7GTB	N709	6BQ5
6PL12	6BM8	CV784	1S5	CV2500	35Z4GT	ECC81	12AT7	N727	6AQ5A
12D17	12AX7	CV785	1T4	CV2514	43	ECC82	12AU7A	OM10	6K8
13D2	6SN7GT	CV797	2D21	CV2524	6AU6A	ECC83	12AX7A	PCF80	9A8
30C1	9A8	CV818	3Q4	CV2526	6AV6	ECC85	6AQ8	PCF82	9U8A
30P18	15CW5	CV819	3Q5GT	CV2747	6U5	ECC88	6DJ8	PCF801	8GJ7
30PL12	16A8	CV820	3S4	CV2901	6Z67	ECC91	6J6A	PCL82	16A8
63ME	6U5G	CV850	6AK5	CV2975	6BQ5	ECC189	6E88	PCL84	15DQ8
150C2	0A2	CV858	6J6A	CV2984	6080	ECC230	6080	PL84	15CW5
150C3	0D3	CV877	7A7	CV3523	6146A	ECF80	6BL8	PL500	27GB5
B36	12SN7GA	CV885	7C5	CV3908	6BH6	ECF82	6U8A	PM04	6BA6
B65	6SN7GTB	CV887	7C6	CV3909	6BJ6	ECF86	6HG8	PM05	6AK5
B152	12AT7	CV901	7Y4	CV3912	1U5	ECH35	6K8	QV03-12	5763
B309	12AT7	CV918	12K7GT	CV3998	6688	ECL82	6BM8	QV05-25	807
B329	12AU7A	CV924	12SL7GT	CV4007	5726	ECL85	6GV8	QV06-20	6146
B339	12AX7A	CV925	12SN7GA	CV4009	5749	ECL86	6GW8	R52	5Z4
B719	6AQ8	CV1186	6F6G	CV4012	5750	EF86	6Z67	STV150/30	0A2
BPM04	6QA5A	CV1287	25L6GT	CV5041	6CL6	EF93	6BA6	UV1	5Y3GT
CV124	807	CV1347	6K8	CV5042	12BH7A	EF94	6AU6A	U52	5U4G
CV133	6C4	CV1377	5AR4	CV5072	6CA4	EF95	6AK5	U70	6X5GT
CV140	6AL5	CV1633	3V4	CV5073	6AM4	EF183	6EH7	U74	35Z4GT
CV283	6AL5	CV1741	6CA7	CV5074	6AF4A	EF184	6EJ7	U76	35Z4GT
CV452	6AT6	CV1800	1A7GT	CV5215	6BL8	EH90	6CS6	U78	6X4
CV453	6BE6	CV1802	1A7GT	CV5307	807	EK90	6BE6	U147	6X5GT
CV454	6BA6	CV1818	1H5GT	CV5331	6ES8	EL34	6CA7	U709	6CA4
CV455	12AT7	CV1820	1H5GT	CV5358	6DJ8	EL84	6BQ5	UU12	6CA4
CV491	12AU7A	CV1823	1N5GT	CV5365	6BQ7A	EL90	6AQ5A	VFT6	6U5
CV492	12AX7A	CV1831	2A3	CV5434	6FG6	EM84	6FG6	W17	1T4
CV493	6K4	CV1832	0A2	CV5810	6EJ7	EN91	2D21	W63	6K7
CV504	6U5	CV1833	0B2	CV5831	6EH7	EZ35	6X5GT	W76	12K7GT
CV509	6V6GTA	CV1856	5Y3GT	D63	6H6	EZ80	6V4	WZ72	6BA6
CV511	6V6GTA	CV1862	6QA5A	D77	6AL5	EZ81	6CA4	X14	1A7GT
CV522	7B7	CV1863	5Z4	D152	6AL5	EZ90	6X4	X17	1R5
CV525	12A6	CV1870	6A7	DAC32	1H5GT	GZ30	5Z4	X61M	6K8
CV543	12SK7	CV1893	6B8	DAF91	1S5	GZ31	5U4G	X63	6A8
CV544	12SK7GT	CV1900	6D6	DD6	6AL5	GZ34	5AR4	X65	6K8
CV546	12SQ7	CV1906	6E5	DF33	1N5GT	HBC90	12AT6	X77	6BE6
CV547	12SQ7GT	CV1911	6F6G	DF91	1T4	HBC91	12AV6	X147	6K8
CV553	25L6GT	CV1928	12BA6	DH63	6Q7	HD14	1H5GT	X727	6BE6
CV562	35L6GT	CV1929	6H6	DH77	6AT6	HF93	12BA6	Y61	6U5
CV564	35Z3	CV1931	6H6	DH118	14L7	HF94	12AU6	Y63	6U5
CV571	50L6GT	CV1932	6J5GT	DH149	7C6	HK90	12BE6	Z14	1N5GT
CV572	6X5GT	CV1934	6J5GT	DK32	1A7GT	HL92	50C5	Z63	6J7
CV574	6X5GT	CV1935	6J7	DK91	1R5	HM04	6BE6	Z729	6Z67
CV575	5U4G	CV1937	6J7	DL33	3Q5GT	HY90	35W4	ZD17	1S5

ACCREDITED
MEMBER
National
Home Study
Council

**SEND
FOR NEW
FREE
FULL COLOR
CAREER
CATALOG
COMPLETELY
ILLUSTRATED**

Find out
about
**RCA Career
Programs**
and the easier, faster
way to learn electronics



RCA INSTITUTES, INC.

Dept. RT-97

A Service of Radio Corporation of America
350 West 4th Street, New York, N. Y. 10014

Please rush me FREE illustrated catalog. I understand that I am under no obligation, and that no salesman will call.

HOME STUDY CAREER PROGRAMS

- | | |
|--|--|
| <input type="checkbox"/> Television Servicing | <input type="checkbox"/> Electronics Drafting |
| <input type="checkbox"/> Telecommunications | <input type="checkbox"/> Digital Techniques |
| <input type="checkbox"/> FCC License Preparation | <input type="checkbox"/> Industrial Electronics |
| <input type="checkbox"/> Automation Electronics | <input type="checkbox"/> Nuclear Instrumentation |
| <input type="checkbox"/> Automatic Controls | <input type="checkbox"/> Solid State Electronics |
| <input type="checkbox"/> Mobile Communications | <input type="checkbox"/> Computer Programming |
| <input type="checkbox"/> Electronics in Spanish | |

CLASSROOM TRAINING COURSES

- | | | |
|------------------------------|----------------------------------|---|
| <input type="checkbox"/> Day | <input type="checkbox"/> Evening | <input type="checkbox"/> Electronics in Spanish |
|------------------------------|----------------------------------|---|

Name _____ Age _____
(please print)

Address _____

City _____ State _____

FILL IN ZIP CODE FOR FAST SERVICE ►

Veterans: Check Here

IN CANADA - THE RCA VICTOR COMPANY, LTD.



**RECOGNIZED
THROUGHOUT
THE WORLD AS**

**THE MOST TRUSTED NAME
IN ELECTRONICS**

Take advantage of this opportunity to train with a leader—RCA Institutes. Home Training or Classroom Training.

**SEND THIS POSTAGE-FREE CARD
TODAY FOR FREE CAREER BOOK.**

BUSINESS REPLY MAIL
No Postage Stamp Necessary If Mailed in U.S.

Postage will be paid by—

RCA INSTITUTES, INC., Dept. RT-97
350 West Fourth Street
New York, N. Y. 10014

FIRST CLASS
PERMIT NO.
10662
NEW YORK, N. Y.



10 Reasons why RCA Home Training is your best investment for a rewarding career in electronics!

1 LEADER IN ELECTRONICS TRAINING

RCA stands for dependability, integrity and pioneering scientific advances. For over a half century, RCA Institutes, Inc., has been a leader in technical training.

2 RCA AUTOTEXT TEACHES ELECTRONICS FASTER, EASIER

Beginner or refresher - AUTOTEXT, RCA Institutes' own method of Home Training will help you learn electronics faster, easier, almost automatically.

3 THOUSANDS OF WELL PAID JOBS ARE OPEN NOW

RCA Institutes can help you qualify for a rewarding career if you have an interest in electronics. Every year, thousands of well paid electronics jobs go unfilled just because not enough men take the opportunity to train themselves for these openings.

4 WIDE CHOICE OF CAREER PROGRAMS

Start today on the electronics career of your choice. On the attached card is a list of "Career Programs", each of which starts with the amazing AUTOTEXT method. Look the list over, pick

the one best for you and check it off on the card.

5 SPECIALIZED ADVANCED TRAINING

For those working in electronics or with previous training, RCA Institutes offers advanced courses. Start on a higher level. No wasted time on material you already know.

6 PERSONAL SUPERVISION THROUGHOUT

All during your program of home study, your training is supervised by RCA Institutes experts who become personally involved in your efforts and help you over any "rough spots" that may develop.

7 VARIETY OF KITS, YOURS TO KEEP

At no extra cost, a variety of valuable specially engineered kits come with your program—yours to keep and use on the job.

8 FROM RCA INSTITUTES, INC. TRANSISTORIZED TV KIT AND VALUABLE OSCILLOSCOPE

All students receive a valuable oscilloscope. Those enrolled in the TV program or courses receive the all-new Transistorized TV Receiver—both at no extra cost and only from RCA.

9 UNIQUE TUITION PLAN

You progress at your own pace. You only pay for lessons as you order them. There's no long-term contract or large down-payment to lose. Even if you decide to interrupt your training, you don't lose a single cent.

10 RCA GRADUATES GET TOP RECOGNITION

Thousands of graduates of RCA Institutes are now working for leaders in the electronics field; many others have their own profitable businesses... proof of the high quality of RCA Institutes training.

SEND ATTACHED CARD TODAY FOR FREE DESCRIPTIVE BOOK

All courses and programs approved for veterans under new G.I. Bill.

CLASSROOM TRAINING ALSO AVAILABLE. FREE CATALOG ON REQUEST. NO SALESMAN WILL CALL.

RCA INSTITUTES, INC. Dept. RT-97
350 West 4th Street
New York, N.Y. 10014

Transistor experiments on programmed breadboard - using oscilloscope.



The Most Trusted Name In Electronics

Construction of Oscilloscope.

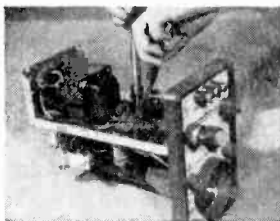

Construction of Multimeter.

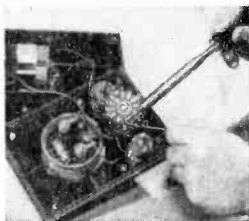

When it comes to tape recorders, there are two basic rules you can bet on. As a matter of fact they're so basic you can't lose. Rule number one is that performance goes downhill from the instant you turn on the power switch but so slowly that a year later you never realize the hi-fi you paid for is now low- or medium-fi. Rule two is to keep your cotton-picking fingers out of the drive mechanism. Sure, there are innumerable articles on how to change rollers, grease gears and overhaul motors. But about the only thing tinkering with the drive will accomplish is to get you one whale of a service repair bill.

Fact is, any recorder—whether it cost \$60

or \$600—delivers optimum performance with a *minimum amount of periodic cleaning and adjustment*. The big thing is to perform the proper cleaning or adjustment *at the right time* to insure like-new performance over a period of years.

Head Care. The most common cause of poor tape recorder performance is dirty and magnetized heads. Instruction manuals usually have something to say about the routine of head cleaning but heaven help the man who tries it on some of the new recorders. The heads and guides are buried so far under a permanent-mount head cover you can't get at them. The trick is to forget about the old favorite, the *Q-tip*. Instead,

**on
the
Care**

and Feeding of Tape Recorders

By **HERB FRIEDMAN**

Much like a fine watch, every tape recorder requires periodic cleaning and adjustment if it is to perform as its manufacturer intended



wrap a thick cotton ball on the end of a cardboard lollipop stick (metal or wood can damage a head), soak it in head cleaner (forget the dinky little brush that comes with the stuff), and literally scrub the heads and tape guides. Regardless how deep the heads are recessed under the cover some part of a large cotton ball will contact the heads. And don't forget to clean the capstan and capstan roller (the rubber pressure roller).

If you believe the nonsense that head cleaner or alcohol destroys rubber, go out and splurge on *Isopropyl Alcohol* (or buy a can of head cleaning *freon* at eight bucks a gallon). But keep in mind that one of the largest hi-fi FM stations has been cleaning

passing over a magnetized head is affected just as if it were passed over a weak magnet. First, noise is *added* to the recording (even on playback). Second, if the head is strongly magnetized some of the high frequencies can be partially erased. Except for those recorders which automatically demagnetize the heads when the power is turned on or off, you can be certain a recording head is magnetized if you have ever sharply exceeded the normal input level (as shown on a VU meter or other recording level indicator). Playback heads do not become magnetized to the same extent as record or combination heads. And generally speaking you can forget about erase heads.

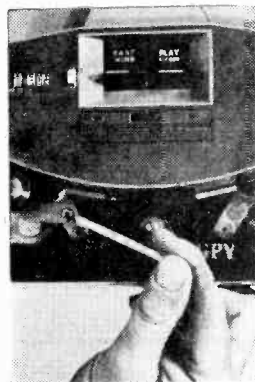
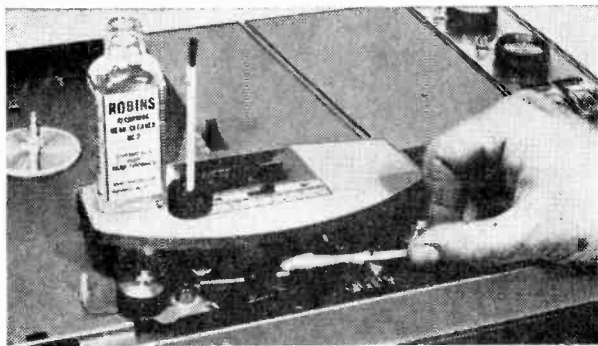

Cleaning hidden heads with homemade swab (above) gets into all corners. Apply grease with lollipop stick (left)—oil, with a wire. Noisy controls are quieted by injecting cleaner (top right) through C-washer's gap, into bushing. Aerosol spray cleaner squirted in openings in rear cover is sure-fire method. Add a touch of grease to pivots and bearings but keep the capstan and pressure pads, rollers spotlessly clean.

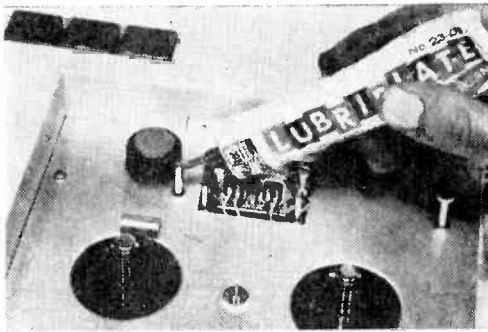

rubber rollers with ordinary head cleaner for fifteen years and has yet to lose a roller or any other rubber component. Just make certain that you use the head cleaner sparingly and don't soak the roller in the stuff.

How often should you clean heads, guides, capstan and roller? If you're fussy, once a day. Once a week if you're not a fusspot; but every *thirty hours* at the *minimum*.

Demagnetize. Another important must is to take care of magnetized heads. Tape

to avoid the noise and high frequency losses caused by magnetized heads, simply demagnetize the heads at least weekly if the recorder gets heavy use, or every thirty to fifty hours. But always demagnetize immediately if you accidentally overload the input (as indicated by a "pinned" recording level indicator). You can do the job with a commercial head demagnetizer which is simply touched to the heads and tape guides, or you can save about six bucks by pulling

TAPE RECORDERS

the trigger on your soldering gun and moving it *slowly* past the heads.

Speaking of demagnetization, never, never use any tool near the heads if it has been picked directly off the workbench. Most tools are or become magnetized, and a screwdriver, pliers or wrench picked off the bench and used to align a head is certain to magnetize the head. Before working near recorder heads *always* make sure the tools are demagnetized. The best way to do this

should change after a tape is recorded the high frequency loss is determined by the magnitude of the misalignment. It is even possible for the misalignment to be so great as to cause almost an effective complete loss of high frequencies commencing at one-third the highest possible frequency. For example, a recorder capable of response to 15,000 Hz could "cut off" at 5000 Hz.

The most common alignment problem occurs over a long time period, and the loss goes unnoticed until a tape recorded on another machine (or when the recorder was new) is played back. Only then is the misalignment noticed, since if it's sufficiently

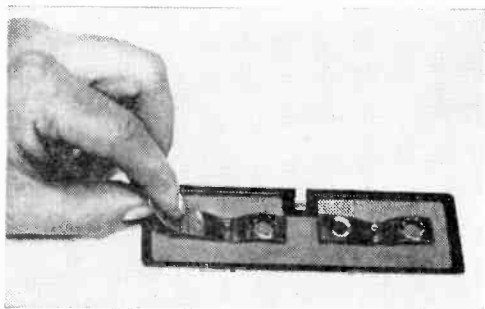

Making battery contacts bright and shiny (above) prevents intermittent operation. Magnetic field at tip of soldering gun (below) is demagnetizing recorder heads.

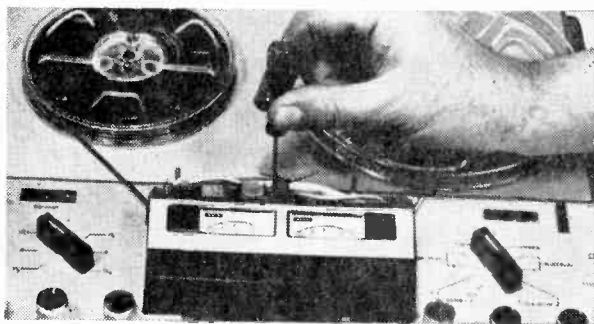

Align heads easily with test tape and VU meter across output (above)—be careful. Signal generator (below) feeds constant signal to recorder for head alignment.

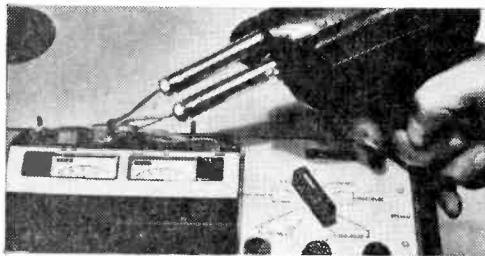

is to place the tools on a bulk tape eraser, hold down the power switch and then remove the tools while the power switch is on. Disconnecting the power while the tools are still on the eraser will probably leave the tools magnetized.

Better Highs. The wider the recorder's frequency response, the greater the high frequency losses if a record or play head changes alignment. Normally, a recorder is adjusted so the gap in the record/play and other heads is at exact right angles to the length of the tape. If the head alignment

great the playback is devoid of highs.

If your recorder uses a combination record/play head—one used for both record and play—realignment is not a big deal. Simply play back one of the tapes made when the recorder was new and adjust the head alignment screw(s) for maximum high frequency playback response. If you're really critical, purchase an "alignment tape" and adjust the head alignment for maximum output. It will probably be necessary to connect some sort of output meter to the recorder's output jack (or across the speaker ter-

minals), then adjust the alignment for maximum indication on the output meter.

If your recorder has three heads you've got a bit of a problem as the record and playback heads must also be in alignment to each other. First, adjust the playback head for maximum high frequency response from an old tape, or maximum output from an alignment tape (and in this case an alignment tape is a much better bet). Secondly, leave the output meter connected to the recorder and apply a sine-wave signal to the input, adjusting the record head for maximum indication on the output meter. The signal from the signal generator should be

input signal. However, if you don't own or can't borrow an audio signal generator you can manage an accurate alignment without one by substituting a second recorder. As in all cases, first align the play head using an alignment tape. Then, transfer the alignment tape to the second recorder, and connect the second recorder to the first. Playback the alignment tape on the second recorder, feed the signal into the first recorder (the one to be aligned) and adjust the first recorder's record head alignment for maximum output. In effect, the second recorder becomes a signal generator.

Regardless of the record head signal

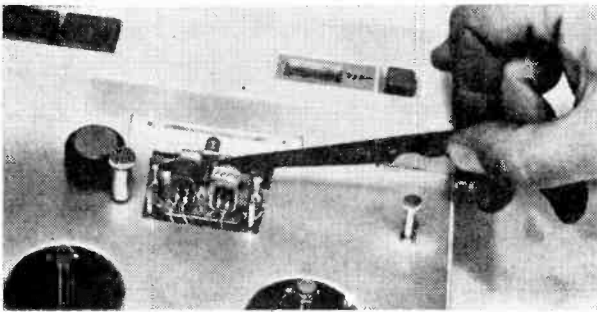

Demagnetized nail file (above) cleans the caked pressure pads in emergency. It is necessary to defeat automatic shut off to check capstan speed without tape in slot.

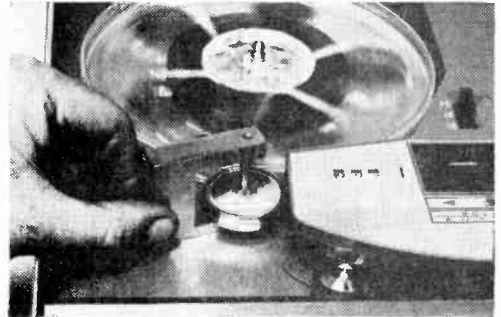

Strobe wheel indicates speed of tape (top) not capstan; quickly indicating slippage. Vacuum removes loose dust (below). Small paint brush will help remove the residue.

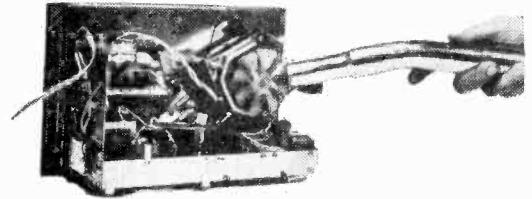
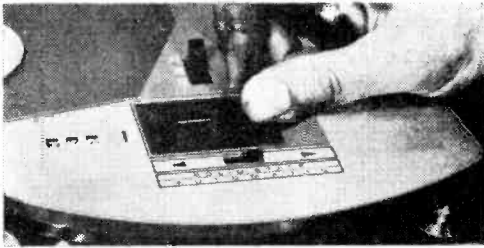

that recommended by the manufacturer for alignment. If in doubt use the recorder's highest rated frequency at the highest speed. As example, if yours is a four-speed recorder with a top speed of $7\frac{1}{2}$ ips and a top frequency of 15,000 Hz perform the alignment at $7\frac{1}{2}$ ips using 15,000 Hz. The maximum alignment frequency should not exceed 15,000 Hz (for ease of alignment) even if the recorder's response is rated higher than 15,000 Hz.

Three-head machines must have their record heads aligned in conjunction with an

source, whether signal generator or a tape recorder, avoid saturating the record head by keeping the input signal about 10 db below maximum recording level. For example, if you usually "peak" the signal to the recorder's VU meter zero mark adjust the alignment signal so it reads -10 db. If the alignment signal is great enough to overload the record head (saturating it), a wide alignment adjustment will show no change on the output meter and you may well wind up with worse alignment than you started with. *(Turn page)*

Tube Check. The final *major* electrical test is the old reliable tube check. Many recorders run the tubes at the design limit, and just routine aging over a period of months, or years, means a sharp loss in performance. This loss goes unnoticed as it happens gradually and there's no ready reference as to what performance had been. Recordists are often astonished by how radically they improve performance simply by replacing tubes. (One well known and expensive recorder is so sensitive to changes in the bias-oscillator tube that the tube must be replaced every two months or so to maintain low distortion.) As a general rule, if your recorder gets heavy service, such as 15 hours or more a week, it's a good idea to check all the tubes every six months.

The Little Things. While insuring maximum electronic performance is most important, slight variations in the mechanical transport of the tape can have a magnified effect on electronic performance. For example, excess hold-back tension will cause a recorder to slow down at the end of the reel. Similarly, reduced capstan roller pressure could reduce drive speed as the take-up reel fills. While this would cause no audible effect on a single reel of tape, it would cause a sound "speed up" if the end of one home-recorded reel were spliced into the beginning of another. A good way to check for this effect is to gauge the capstan speed with a strobe wheel when no tape is driven. Then check the tape speed at the end of a reel

with the strobe wheel. If the strobe bars don't stand still under all test conditions it's best to consult a service technician.

Excess hold-back tension can be caused by dirty or grimy pressure pads. Replacements are cheap (pennies) so pressure pads should be replaced as soon as they look dog-eared. If you're set for a big taping session and you notice the pads have passed the point of no return but you've got no replacements, you can do some emergency surgery by filing the pad's face clean with a nail file. Just make certain you don't file the head, and take care to demagnetize the nail file before you place it near heads. (Never, ever use emery boards.)

Emergency treatment will often cure noisy volume controls. Simply squirt some *carbon control cleaner* or *No-Noise* down the shaft with a needle injector and rotate the control a few times. Similarly, emergency treatment is often required on a portable recorder's battery clamp(s). If you're plagued by intermittent battery connections, just rub down the clamps with a strip of crocus cloth (available in most hardware stores).

Finally, while drive mechanism repairs are best left to a service technician, keep in mind that most rubber-idler type drives fail because of dirt. And don't forget that the fan blades on the capstan motor are constantly sucking dust and grime into the case. Anytime you have occasion to remove the recorder from its case, like when checking tubes, give the drive a thorough going over with the vacuum. But never blow the dust away, since blowing only moves the dust to another component. ■

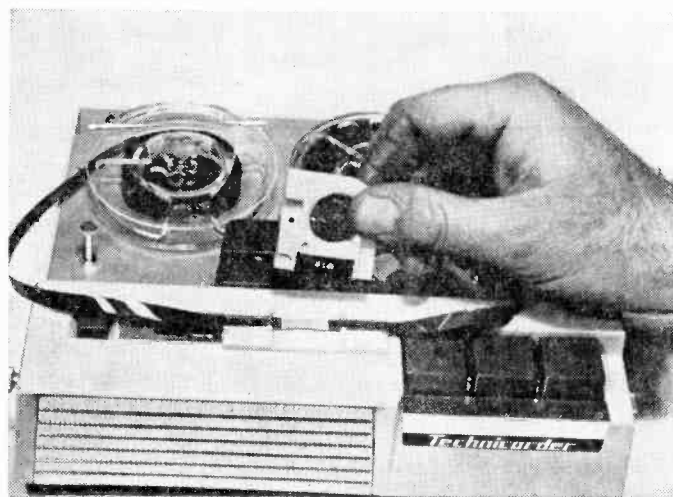

If you haven't mastered the art of splicing tape without mechanical help better attach one of those self-sticking splicing blocks to the recorder. The cutter and trimming blades have a protective housing and can be put into your pocket.

What To Do

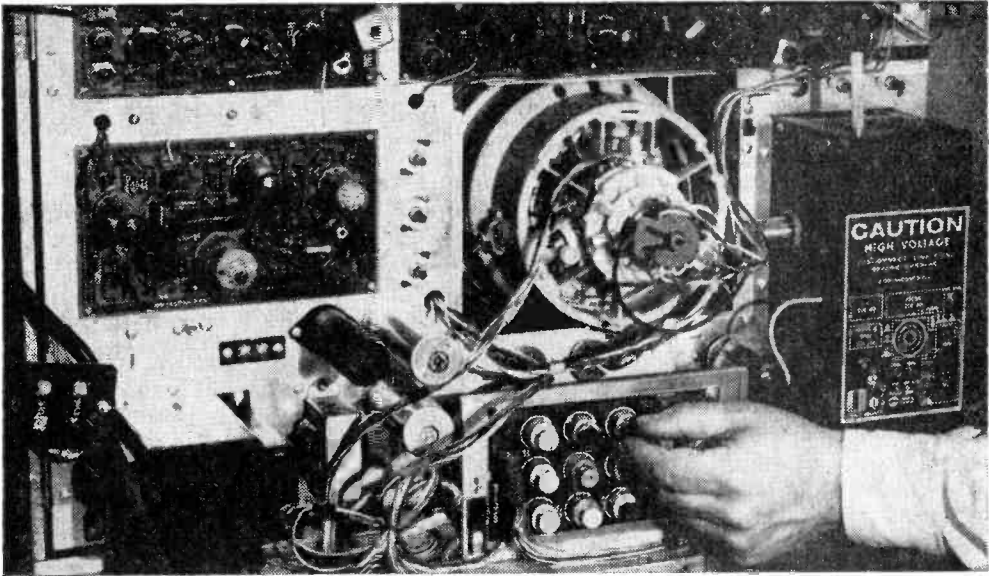

For Truest Blue (and red) (and green)

Though color-TVs can be frighteningly complex instruments for the uninitiated, they ultimately turn into old friends for the owner-in-the-know

By LEN BUCKWALTER

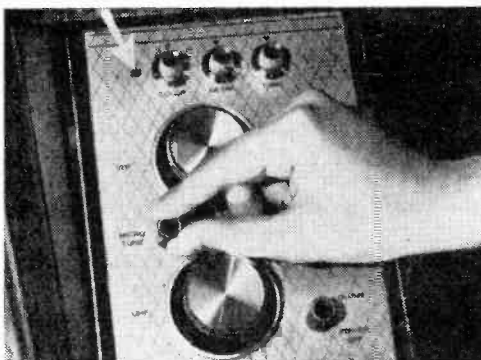

Fine-tune control and indicator light (arrow) make for easy tuning on many modern color-TVs, but they can't correct misadjustments.

Anyone who has switched from black-and-white TV to color viewing makes a disturbing discovery. No longer do little picture distortions—out-of-round circles or misshapen figures—sink into the background. Color permits less of a compromise. Misadjustments may spring out at the viewer to clutter the picture with a spectrum of colorful smears, nightmarish tints and ghoulish hues. We don't mean "fault"-type problems—outright failure of tubes, parts or antenna. These need servicing. Rather, it is the slow drifting that comes with time, or the intrusion of other factors which affect performance of an otherwise trouble-free set. The manufacturer anticipates such problems with a whole series of adjustments for correcting such error. Not just the user knobs on the front panel, but a complement of in-back controls that need an occasional touching up. They keep colors clean and the monochrome picture truly black and white.

Besides long-term drift, another significant force is at work. It is the stray magnetic field. So sensitive is the color receiver to magnetic forces that just moving the set around the room could deteriorate color, not to mention

going from room to room or house to house. Even the earth's weak magnetic field has been singled out as a disruptive influence. Stray magnetism and inevitable drift, however, are readily corrected in the steps to follow.

It's probably occurred to some viewers that symptoms of misadjustment may really be signs of deeper trouble. In many instances this is true. But until you've developed a sharp eye for these differences, there's the trusty trial-and-error approach to provide the answer; if routine adjustments to be described won't restore performance, chances are the circuits need servicing. Adjustments can be performed without major chassis removal, often requiring little more than removing the back cover.

How difficult? It follows the old law: the beginner flounders around at first, the experienced adjuster breezes through the job in mere minutes. So don't expect push-button precision at first. It takes a little time to get the feel and effect of the various controls. One thing in your favor: the set, though uncomfortable to view, may be just slightly out of adjustment. This means you can avoid time-consuming confusion by not moving any controls more than just a slight amount while observing the desired result. And don't despair over two factors peculiar to color TV: (1) you rarely set a control once and leave it there. Interaction is the rule, so be prepared for much repetition and (2) aiming for utter perfection is not only impossible but often a waste of time. Color TV is still a miracle despite traces of color error, especially at screen edges, or some color fringing around some objects in the black-and-white program. The adjuster tends to see the screen with a far more critical eye than when he sits five or more feet away as a program viewer.

Required Equipment. Unlike the simpler black-and-white receiver, which usually can be adjusted by eye, the color set needs at least one test instrument. It's the color generator, a device which displays on the screen a pattern of dots, bars and other images which serve as a reference. Without such a unit, the adjustment job becomes hopelessly complex. At least one kit manufacturer markets a suitable generator in kit

form for approximately \$65. Commercially wired units begin at higher prices. Clipped to the antenna terminals of the TV receiver, the generator "transmits" the desired pattern selected by a knob on the front panel. Not only is the device needed for critical color adjustments but also serves for lining up certain black-and-white adjustments.

Next piece of equipment is the degaussing coil, the unit which demagnetizes stray pick-up by the picture tube. Although such units are available, one may be inexpensively assembled by following the illustration in Fig. 1. You'll need about four pounds of No. 20 enamel-covered ("magnet") wire. This is wound around some temporary form of 12-

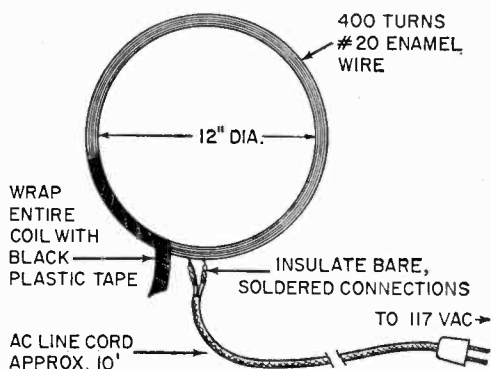

Fig. 1. For color TV receivers without automatic degaussing, a simple degaussing coil is needed.

inch diameter for 400 turns. After removal from the form, the coil is held together by a wrapping of black plastic tape. A long AC cord (with plug) is attached to the two free ends of the coil.

A handy accessory during adjustments is a mirror. It's awkward, if not impossible, to get a good view of the entire screen while manipulating certain controls from the rear of the set. The mirror should be large enough to give a total view of the screen when placed in front of the set. A chair provides a good support of approximately correct height. (Two additional items, "cheater" cord and hex tool, are described later.)

Finally, the set's service manual should be on hand. Now that numerous TV makers have entered the color field, there are apt to be variations in location and set-up of controls from one set to the next. The step-by-step discussion to follow applies generally, but the manufacturer's special comments should also be checked.

Major Steps. Adjusting the color set requires no grasp of complex theory, but a quick preview of major steps (see Fig. 2) and why each is performed could prove helpful. The job begins with:

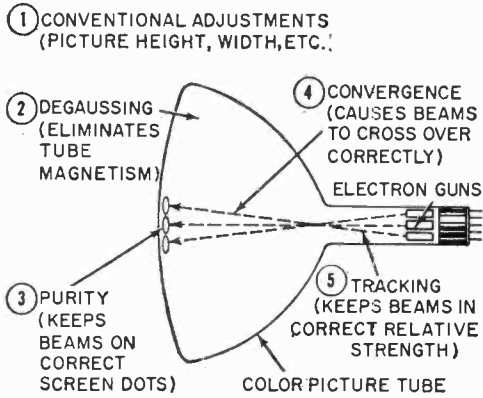

Fig. 2. The five major steps to accomplish in adjusting color TV for optimum performance.

1. Conventional Adjustments. These are the familiar controls found on all TV receivers, monochrome or color. They include height, width, focus and linearity (see Fig. 3). Unless preset for proper performance, adjustments which control color will be seriously affected. Even setting of horizontal and vertical hold controls should be done with care. Misadjustment of horizontal hold can cause fanning out at the top of the picture, while a vertical hold set improperly may produce slanting retrace lines. (A suitable crosshatch pattern from the color generator can serve as a guide for these initial picture adjustments.)

2. Degaussing. This is the demagnetizing step mentioned earlier. It cancels out magnetism picked up by the metal shell of the picture tube and surrounding parts. The operating principle of the degaussing coil is similar to that of an erase head in a tape recorder: by applying a rapidly changing magnetic field (provided by 60-cycle house current), the magnetized object is returned to a neutral state. (Degaussing will not be required for the newly-announced receivers by RCA; it's done automatically by an internal circuit.)

3. Purity. If the color set cannot produce single, pure colors, it cannot be expected to properly render thousands of color mixtures required during a color program. This in-

roduces purity—first major color adjustment. Done in two steps, it lines up three beams from the electron gun in the neck of the tube so they fall precisely on their respective screen color dots—red, blue and green. Actually, purity is accomplished by using the red beam only. The other two colors will automatically fall into place.

4. Convergence. Not only do the three beams have to center properly on the screen, they must also come to a point just before reaching their corresponding screen dots. The beams are magnetically squeezed together (converged), and form a point just before striking the screen. Travelling a slight distance further, they cross over, fan out slightly, then strike their corresponding dots. To achieve this focusing effect for the entire screen surface, convergence is done in two steps. The first sharpens the image at screen center, the second corrects the problem of variable distance between guns and screen. (The beams must travel farther to hit the edges of the screen.)

5. Tracking. Although the receiver is designed for color reception, its black-and-white performance is still critical. This final adjustment keeps color out of the monochrome image. Since the black-and-white picture is created by mixing red, blue and green in a fixed amount, any upset intro-

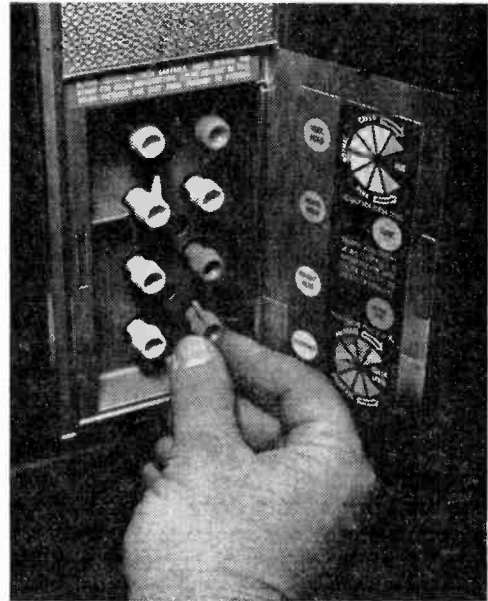

Fig. 3. All conventional controls—hold, width, linearity, etc. must be carefully adjusted first.

duces undesired color tinting. This is corrected by adjusting the beam strength of each electron gun for the proper gray shading.

Preliminary Set-Up. Decide now where the set is to be located in the room for normal viewing—and leave it there throughout the whole course of adjustments. Some of your work will be undone if the cabinet is moved to a convenient area for better access, then returned to its permanent place. Plumbing pipes, air vents or other masses of metal unpredictably warp the surrounding magnetic fields which influence purity and convergence.

Room lighting is another factor which may be considered. Is the set to be viewed as daylight enters the room, or under artificial illumination? Photo fans will see the analogy; outdoor color film is balanced against the blueness of natural light, while the indoor film type takes into account the yellowish hues of artificial light. In adjusting the color set, these lighting factors affect the outcome. A set adjusted during the day for a good black-and-white picture, for example, can assume a hue of color under lamplight. Adjustments, if possible, should be made under normal viewing conditions. Since most viewing is ordinarily done in the evening, it's helpful to adjust at that time or draw the shades and exclude natural light.

Other preparations. Turn on both set and test generator in advance. Both units should be allowed about 20 minutes to warm up and stabilize at operating temperature. Also, the back cover of the set is removed. There is some variation in interlocks here, devices which automatically kill dangerous voltages when the cover is removed. This safeguard is designed to protect against accidental shock. During adjustments, however, the set must be fully powered with the cover off. This usually requires the use of a special "cheater" cord to defeat the interlock. A suitable one for the particular set should be obtained, if necessary.

The matter of safety is even more critical for color than in the conventional black-and-white receiver. Voltages in color circuits run up to some 24,000 volts. While none of the adjustment points bear voltage, care should be exercised to avoid any accidental

contact with nearby, exposed parts. There is no need to open the high-voltage cage or remove the cap plugged into the picture tube.

Some sets have removable top or side panels for access to certain internal controls. Others may have a springy wire which shorts the high voltage when the back cover is removed. These and other variations should be checked in the manufacturer's literature. Let's consider now, step-by-step, the various color adjustments. It's assumed that the conventional black-and-white settings (width, height, etc.) have been properly set.

Degaussing. (In this first step the receiver may be warming up, but it does not matter if the set is off during degaussing.) Degaussing is a simple procedure but one that requires careful technique. Don't be surprised if the coil warms up after plugging it into house current. It is designed solely to be powered for the short time required for the job. (Some sets may have "rim" or "field-neutralizing" magnets. If so, they must be retracted before turning on the degaussing coil.)

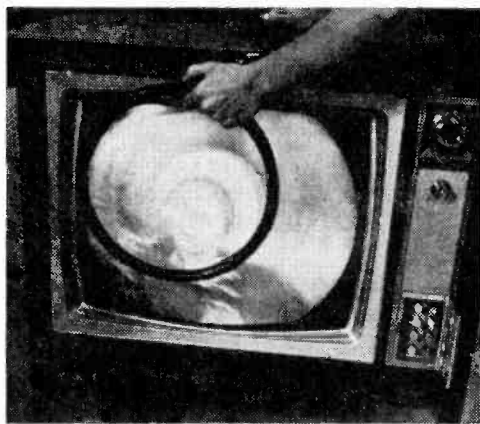

Fig. 4. Degaussing rids picture tube and other parts of stray magnetism that affects color.

As shown in Fig. 4, the coil is held with its flat side about an inch from the screen. Move it in circles over the whole area of the screen's face-plate and overlap into the bordering mask area to rid that region of possible magnetism. This part of the operation is done for about a minute. Now slowly back away with the coil, holding it in the same parallel position as before. When you've reached a distance of about six feet, turn the coil at right angles to the screen (nar-

row side points toward set). Now it's safe to pull the plug out of the wall. Another precaution: don't use a plug that is loose in the wall socket. Any make-break in AC power during degaussing can remagnetize the tube.

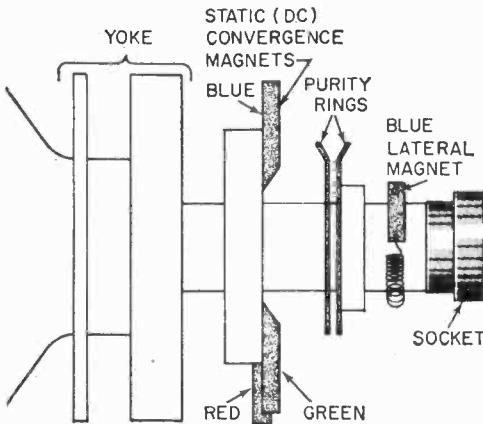
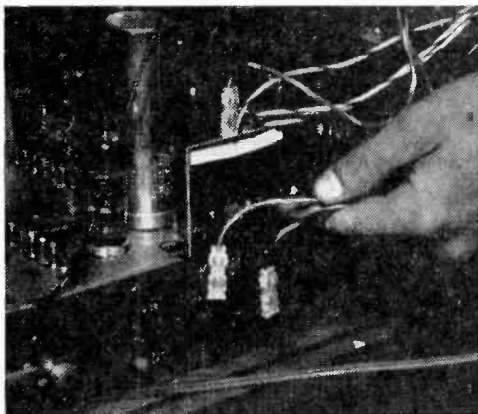

Fig. 5. Purity and static convergence adjustments are made on picture tube behind yoke.

Purity. This 2-step job (Fig. 5) begins by eliminating any possible source of interference on the screen, done simply by removing one of the receiver's I.F. tubes, or unplugging the I.F. cable running from tuner to chassis. (Don't forget to replace these after purity adjustments are completed.) Next is completely disabling blue and green electron guns in the picture tube. Only red

Fig. 6. Before making purity adjustments, disable blue, green guns by method set provides.



will operate at this time. In the recent receiver illustrated in Fig. 6, note that blue and green guns are deactivated by removing two clip leads from a terminal strip. For other sets, a small commercial adapter is plugged into the picture-tube base. It has switches for disabling desired guns. (Such adaptors are often provided with the color dot-bar generator.) Some manufacturers specify clip leads for shortening out the guns.

Turn the set's contrast control fully off, brightness control to about halfway. The screen should now be essentially red. Locate the movable tabs (see Fig. 7) on the purity

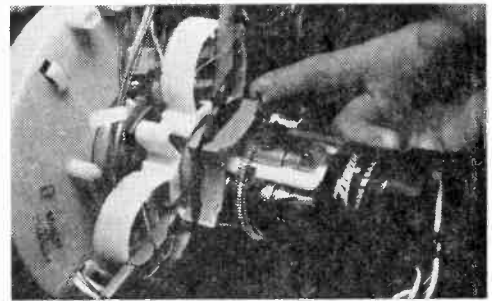

Fig. 7. The red area on the screen is moved to the center using the tabs on the purity rings.

rings and make the red color move to the center area of the screen. Some back-and-forth adjusting might be necessary. Not only should the red area predominate at the center, but its color be as uniform as possible. Step 2 in the purity adjustment is sliding the yoke back and forth to cause the red area to fill the entire screen (see Figs. 8 and 9). (There's a screw clamp to loosen the yoke.) Note that the yoke does not nudge up against the bell-shape rear of the picture tube as in

① BRING RED AREA TO CENTER OF SCREEN WITH PURITY-RING ADJUSTMENT

② FILL COMPLETE SCREEN WITH RED BY SHIFTING YOKE POSITION ON TUBE NECK

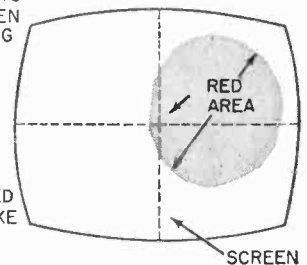

Fig. 8. The red area of the TV screen has to be centered and then expanded to fill the screen.



Fig. 9. Shifting the yoke along the tube axis causes a beam deflection that covers screen.

black-and-white sets. There is some play to permit purity adjustments.

The result of these steps should be uniform, uncontaminated red that slightly extends beyond (overscans) the borders of the picture-tube mask. In some sets, rim magnets around front of the edges of the picture tube are adjusted for correcting color impurity existing out at the edges of the screen.

Convergence. For this step, the color generator is clipped to the antenna terminals in the set-up illustrated in Figs. 10 and 11. (Be sure the I.F. tube or plug removed earlier is back in place.)

The aim of convergence is a series of adjustments to produce pure white dots throughout the complete screen (see Fig. 12). Done in two major steps, static (or

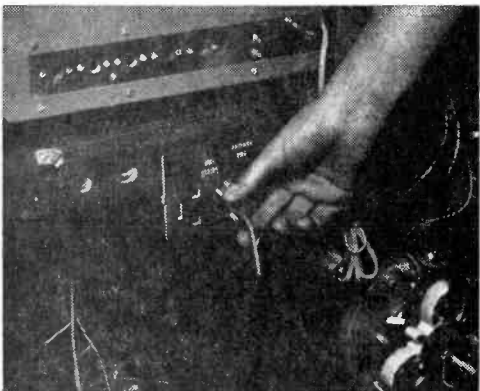

Fig. 10. The color generator output is coupled to the television receiver's antenna terminals.



Fig. 11. Color generator is tuned to frequency of an empty channel and set to generate dots.

DC), and dynamic convergence, it should be possible to apply the right amount of correction. Begin with static convergence, done with three movable magnets (see Fig. 13) which can be slid in and out of their holders. During this step kill the blue gun, but keep red and green guns active. By careful oper-

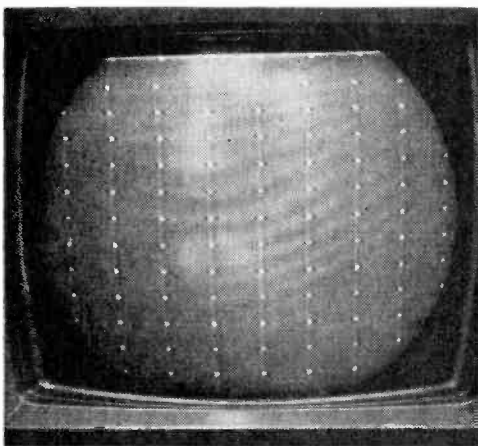

Fig. 12. Dot pattern is used during most color adjustments; is also used for conventional ones.

ation of red and green magnets it should be possible to bring together close-spaced red and green dots on the screen. As they merge, they form a single yellow dot. It's especially important that these static-convergence adjustments be made while viewing dots only at the *center* area of the screen, as shown in Fig. 14. Now activate the blue gun. Its magnet is slid to cause the blue dot to overlap the yellow dot. An additional control—the blue lateral magnet clipped on the tube neck near the base—permits side motion of the blue dot. As in other adjustments, static

convergence requires some juggling back and forth among controls to achieve satisfactory results. The end product should be pure white dots in the central screen area.

Controls for dynamic convergence, which bring together dots lying outside screen center, are generally mounted on a separate "convergence board." In many instances (see Fig. 15) long cables to the board permit it to be mounted conveniently on the rear top edge of the cabinet. Note how it is temporarily fastened in place by two screws. Thus, controls are accessible while the screen is viewed directly (Fig. 16).

A typical convergence board layout appears in Fig. 17. The various controls are divided into two major screen areas; horizontal and vertical. With the color generator producing the same dot pattern used earlier, begin with vertical convergence, the six knobs on the board's left side. During these

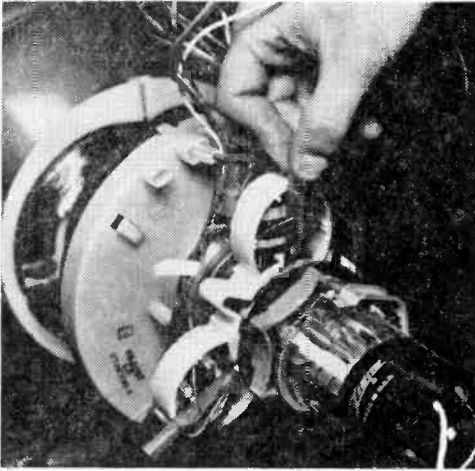

Fig. 13. Static convergence magnets are located in holders clamped around neck of tube.

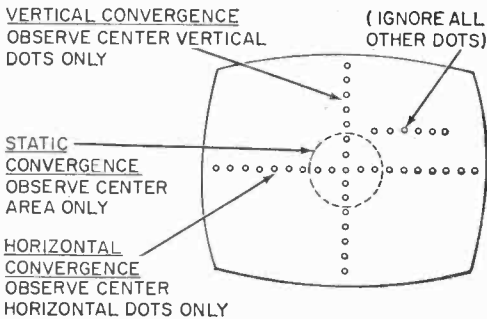

Fig. 14. In static convergence adjustments, observe only dot pattern in center area of screen.

adjustments, it is important to view only the *middle vertical row* of dots, as pictured in Fig. 14. All others are ignored. Red-green controls can be adjusted first, and the blue gun turned off at this time. While watching the vertical column of dots, carefully turn Red Tilt, Red Amp, then Green Tilt and Green Amp in an effort to merge red and green dots so they form single yellow dots. Following this, the blue gun is restored and Blue Tilt and Blue Amp adjusted so the blue dot overlaps the yellow dot for the desired result; a pure white dot, more specifically, a complete vertical row of white dots.

This process is apt to be confounding at first due to interaction—turning of one control upsets the setting of another. And, in fact, when upper and lower dots appear to be perfect, *center* dots in the vertical row go out of whack. This is to be expected. The remedy is to go back and touch up the magnets used earlier for static convergence to re-align the center.

There's another approach to dynamic convergence which might prove helpful until more experience is gained. This is to leave the blue gun on, then adjust red and green controls to bring those dots into line with blue (which serves as a reference). Also, some technicians prefer not to use the dot pattern at all for convergence. They switch the generator for a crosshatch pattern (see Fig. 18). Here, only the vertical column or line at the center of the TV screen is

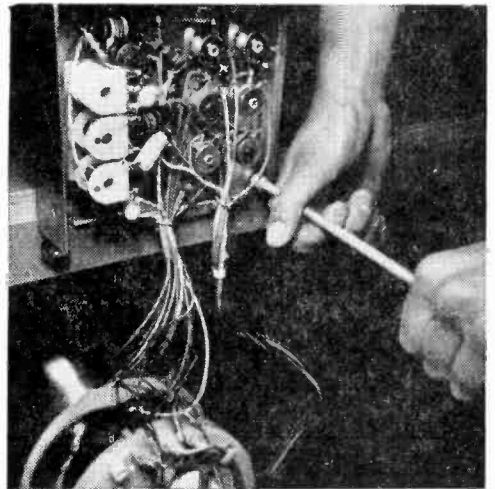

Fig. 15. For convenience, remove the dynamic convergence control board and secure where accessible for your tools and for visibility.

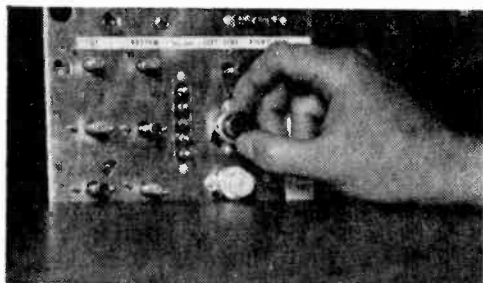

Fig. 16. When "board" is secured to top rear of set, it can be adjusted while viewing screen.

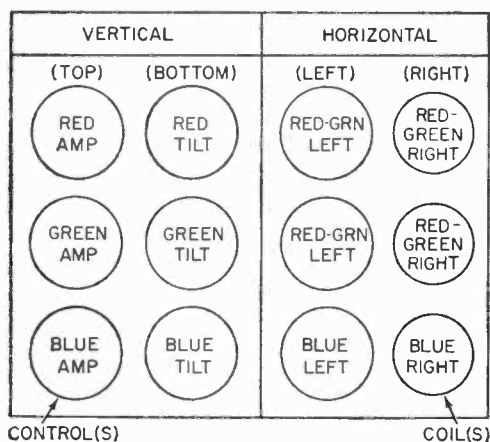

Fig. 17. The dynamic convergence board layout conveniently groups horizontal and vertical controls into logical position and color pattern.

viewed for vertical convergence adjustments.

Horizontal convergence is next, a procedure not unlike the one above, only now the *middle horizontal row* of dots (or lines for crosshatch) comes under adjustment (see Fig. 14). There is a difference; red and green occur *together* on each of the two left and right controls. Thus, the red and green color dots will move at the same time. Blue, as shown, has its own individual controls. Also, the extreme right-hand controls are not usually provided with knobs, but require the insertion of a plastic hex-type aligning tool. After turning off the blue gun, the various red-green controls are used to produce single yellow dots on *right* and *left* halves of the screen over the entire middle horizontal row. When yellow dots are visible, activate

the blue gun and adjust the two blue controls. As blue overlaps yellow the desired white dots should appear. Those blue controls only move the blue dots up and down. For side to side motion, it is necessary to return to the blue lateral magnet mentioned earlier. Again, static convergence (on screen center) may be affected by dynamic convergence, so some back-and-forth adjusting might be in order. It's a good idea, too, to make a final check of color purity, described in the preceding section.

Tracking. After purity and convergence are completed, output of red, blue and green electron guns is adjusted. This assures that a correct proportion of primary colors will be delivered for creating the black-and-white picture. The controls are usually at the rear.

Although tracking controls may differ in number and marking, the general idea is as follows: First tune to an unused channel and

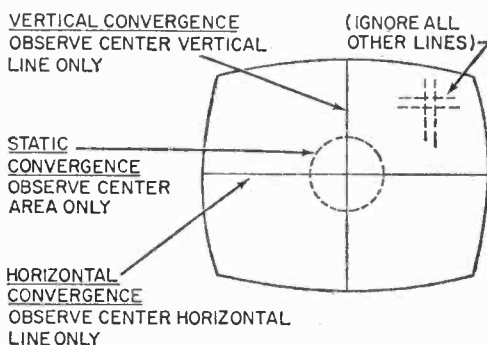

Fig. 18. Color generator can be set to give a crosshatch pattern for convergence adjustments rather than dot patterns discussed.

turn the set's contrast and front-panel color controls to minimum. This should fill the screen with white light (or raster). With the brightness control turned up (though not to maximum) adjust red, green and blue screen controls for best, color-free white light. If, for example, blue is apparent, back off slightly on that control.

This completes the job. How well does a color TV stay in adjustment? There is no set period, but you can expect that, with normal conditions, convergence remains fixed for fairly long periods, say upwards of two years or more. Any jostling, magnetizing or moving the set especially affects color purity. But knowing when to repeat the job is the easiest step of all. During day-to-day viewing, your eye will make that decision. ■



how to SAVE MONEY by CHECKING TUBES at home

■ A whopping number of troubles—more than 80%—that strike a TV set stem from ailing tubes. And TV's aren't alone. As a matter of fact, if it's electronic, you name it and—solid-state excepted—a tube tester is bound to save you money. If you're skeptical, just add up your service bills over the last few years (not to mention miscellaneous extras). Chances are they could have fully financed your own tester—and then some.

Though testers come in all sizes and guises, the inexpensive models, like the ones in our photos, are fully capable of putting the finger on the major causes of tube failure—open filaments, low emission, and shorted elements. These units, all selling for under \$50, are the popular *emission* testers.

Hidden Treasure. Testing them yourself saves service calls but there are other bonuses, too. Cost of tubes can be less. The drugstore or supermarket may shave the price some, but buying at a radio distributor should reduce the tag by nearly one-half. Then, too, there's less chance of getting a wilted number that's already been pounded into several other sets.

And consider these other benefits. Receivers with series-string tubes (marked "AC/DC") cause every tube to grow dark

TUBE CHECKING

when just one filament opens. With no tester you have to pull every tube, put them in a sack, and run them through the juke-box checker at the local pharmacy. (And you're lucky if the tester itself isn't out of order.) This kills an hour or more between tube-pulling and tube-plugging, which means you more than likely will miss the last crucial moments of Perry Mason. (And while you're at the drugstore you might pick up some elixir which you didn't need anyway.)

Another trap you'll sidestep with your own checker is a new boo-boo tube. It happens when you suspect a specific number is bad. You insert a new tube in the socket and wait for the trouble to clear. If the symptom persists, next logical conclusion is that some circuit component within the receiver is faulty. So you pull the chassis and peck for hours—never suspecting that villain is the *new* tube. For though manufactured under controlled conditions, new tubes have been known to pack the occasional defect. And the point is that you can save much anguish by checking the new ones, too.

The tube tester can rescue you from another misleading symptom, the one where a new tube (which tests good) fails to clear up a fault. In older gear, a group of weak tubes might contribute to the trouble. The checker can isolate them and possibly save chassis pulling.

What They Test. A major (but not most important) test administered by these inexpensive checkers is *emission*. This is a measure of the number of electrons boiling off the tube's hot cathode. As the cathode ages, its active coating degenerates and reduces the tube's electron supply. A tester pinpoints this failing quicker than Jack Robinson.

The test for *shorts* is also significant. Since a tube has fine wires and elements that are close-spaced, vibration or mechanical failure could cause internal short-circuiting. A wide black bar in a TV picture, for example, is often caused by a heater-to-cathode short which introduces hum modulation on the picture signal.

Filament continuity is another significant test, since no emission can occur unless the filament is operating. Some checkers also reveal *leakage* between elements, render a *noise test*, and detect *open elements*. The thing to remember is that these checks tend to be approximations that depend heavily on

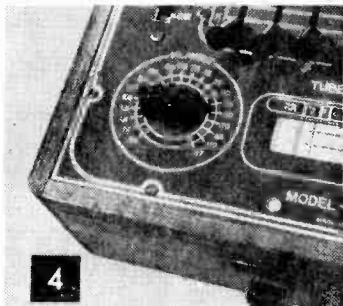
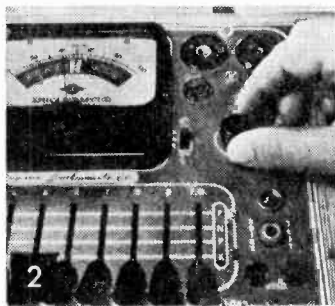
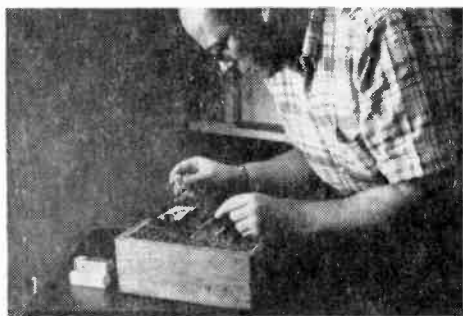

the circuit in which the tube functions. Leakage or noise, for example, might show up during tests but have negligible effect on receiver performance.

Typical Testing. You're seated at the controls of your checker, itching to plug in a suspicious tube and start spinning knobs and pulling levers. But Stop . . . Don't Turn That Dial! Tube checking must be done in orderly sequence if the cure isn't to prove worse than the illness. All checkers come with special instructions, but here's what you can generally expect.

Before inserting the tube in a socket, its number must be located on a roll chart or in a book. And it'll pay to follow instructions carefully when setting various controls. Otherwise you might plug a 6-volt tube into a socket previously set up for a 50-volt number, in which case the 6-volt filament would evaporate faster than cheese at a mouse christening.

Next, the line-voltage knob must be adjusted while watching the meter pin and a reference line. This assures that voltage applied to tube elements is correct. Now you are ready to plug in the tube and give it a few minutes to reach operating temperature.

The first test is usually for shorts. Reason is that this test protects the checker's me-

ter. A shorted tube could draw excessive current and burn out the meter coil. Shorts, however, are usually indicated on a neon lamp which can't fall victim to this plight.

Don't be misled if the lamp glows for a split-second while a knob or lever is turned during shorts tests. It's simply a normal surge of capacitive current between tube elements. But if the glow continues, the tube's ready for retirement. Also remember that no shorts test is complete until you have tapped the tube with a finger while watching the neon lamp. If it flashes, loose tube elements are probably the reason. Often a leakage test is run at this time. The neon lamp is used to detect tiny current flow between tube elements.

If the tube passes these tests it's measured for emission. This is read on the "Bad?-Good" scale on the meter. Keep your eye on the pin for a few moments. If it drops below the "Good" portion of the scale, falling emission might mean the tube's useful life is nearing an end.

Test With Caution. The emission-type checkers tell much about a tube's condition—especially outright failure. But there will be borderline cases where these relatively simple instruments cannot provide a "go or no-go" answer. Here are cases where you'll have to exercise judgment: (Turn page.)

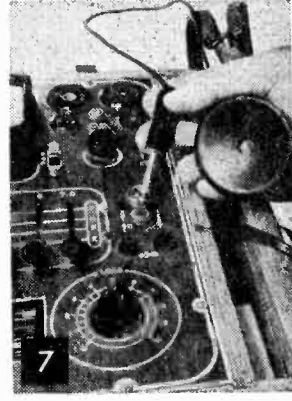
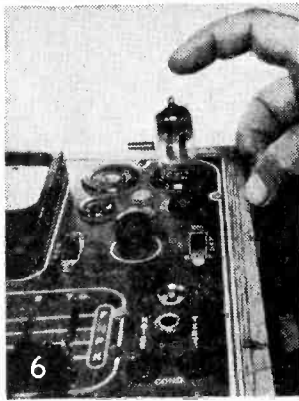

Once you own your own tester, you can check tubes on the spot (1), often pinpointing troubles in a matter of minutes and saving precious dollars at the same time. Before plugging in tube, adjust line-voltage control (2), then place knobs or levers (3) in correct position for tube you're about to check. Setting for filament voltage (4) is especially critical, since a voltage that is too high will quickly blow out the tube. With tester readied, tube is then plugged into appropriate socket; if tube has grid cap (5), it should be connected to special lead supplied. Test for shorts (6) involves tapping tube with finger while observing neon indicator; noise test (7) may reveal hidden cause of circuit malfunction and usually requires use of an external earphone.



TUBE CHECKING

- **Shorts.** After using the checker for a while, you may notice that the neon lamp can glow with differing degrees of brightness on shorts tests. You can reject a tube which produces a bright orange glow, but often the tube that causes a faint glow is still reasonably good. It may serve in less critical circuits, such as those used for audio. Such tubes, however, should be eliminated in high-frequency sections of a receiver—the front end and IF strip, for example.

Occasionally, you'll find that tubes in critical circuits like a TV tuner can check OK and still be inoperative in the set itself. This is especially true of front-end oscillator tubes. A classic symptom is when a TV set receives the 2-through-6 band, but fails on higher channels. Small changes in the tube, not perceived by the checker, kill oscillation at higher frequencies.

- **Emission.** Low emission portends short tube life, and this is reason enough for the professional service technician to replace the tube. He, after all, must guarantee performance. But for your own set, you might gam-

ble on a few thousand more hours of performance from tubes which read in the "7" region or at the top of the "Bad" scale. Again, this applies chiefly in non-critical circuits like audio. And always bear in mind that no tube checker should be expected to yield computer-like precision. But a little experience in handling the instrument can take you a long way toward understanding its particular limitations.

Special Features. Emission testers in the under-\$50 category differ somewhat in superficial features. The austere, stripped-down models may omit exotic tube sockets like the nuvistor and compactron. Too, these instruments may rely on a book, rather than a more convenient roll chart, for reading out data. As price goes up, there may be an adapter for checking picture tubes, or even provision for rejuvenating them. Many models make replacement charts available as new tubes come along.

What lies beyond the emission tester? It's the transconductance type, an instrument which more closely duplicates actual operating conditions encountered by tubes. But these advanced models, even in kit form, often cost more than \$100. The low-cost emission tester, however, is often quite capable of turning in a creditable performance for routine servicing. ■

WHERE TO WRITE FOR MORE INFORMATION ON LOW-COST TUBE TESTERS

Heath Co.
Benton Harbor, Mich. 49023

EICO Electronic Instrument Co., Inc.
131-01 39th Ave.,
Flushing, N. Y. 11352

Allied Radio Corp. (Knight)
100 N. Western Blvd.
Chicago, Ill. 60680

Lafayette Radio Electronics Corp.
111 Jericho Tpke.
Syosset, N. Y. 11791

SECO Electronics, Inc.
1201 S. Clover Dr.
Minneapolis, Minn.

Radio Shack Corp.
730 Commonwealth Ave.
Boston, Mass. 02215

Conar
3939 Wisconsin Ave.
Washington, D. C. 20016

Electronic Measurements Corp.
625 Broadway
New York, N. Y. 10012

Olson Electronics, Inc.
2605 S. Forge St.
Akron, Ohio 44308

Accurate Instrument Co., Inc.
2435 White Plains Rd.
Bronx, N. Y. 60467

Mercury Electronics, Inc.
111 Roosevelt Ave.
Mineola, N. Y. 11501

Precise Electronics & Development Corp.
76 E. 2nd St.
Mineola, N. Y. 11501

Sencore, Inc.
426 S. Westgate Dr.
Addison, Ill. 60101

TUNING UP THE ALL AMERICAN 5



By Mannie Horowitz

Modern radio as we know it today, is due to one great invention—namely the superheterodyne receiver. Sure people used radios before the circuit was widely adapted. The multi-dial TRF (tuned radio frequency) set was quite popular in the '20's—especially if you could afford one. However, commercial five tube radios as we know them today, originated with the low cost superheterodyne circuit. This circuit has proven itself so fine and effective that it has been adopted for use in practically every FM receiver as well as for the popular five-tube, AM radios flooding this country.

As was the case with the TRF receiver, the RF signal is selected by varying the capacitor in the resonant circuit. This signal

is fed to the first tube, known as the mixer, converter, first detector, or anything else you may wish to call it. Along with this RF signal, a second signal, which is generated in the receiver, is fed to the mixer. The frequency of the signal generated by this local oscillator in the receiver, is 455 kHz *above* the frequency of the radio station. Thus, if the radio station broadcasts on a frequency of 1100 kHz, the oscillator frequency is set to $1100 + 455$ or 1555 kHz. If the radio station broadcasts on a frequency of 880 kc, the frequency of the oscillator is set to $880 + 455$ or 1335 kHz. The frequency generated by the local oscillator is varied by a capacitor in the oscillator circuit, as shown in Fig. 1.

It is quite simple to accomplish the varia-

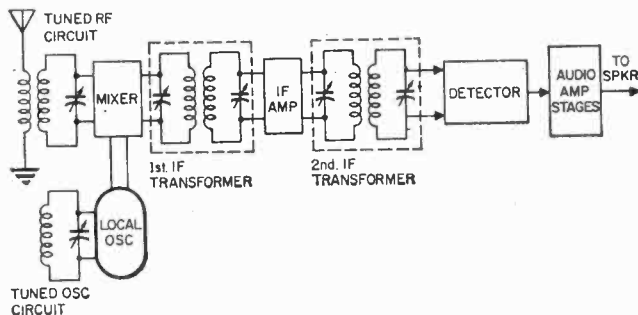

Fig. 1. In the superheterodyne receiver, the incoming RF signal is reduced to an intermediate frequency in the mixer.

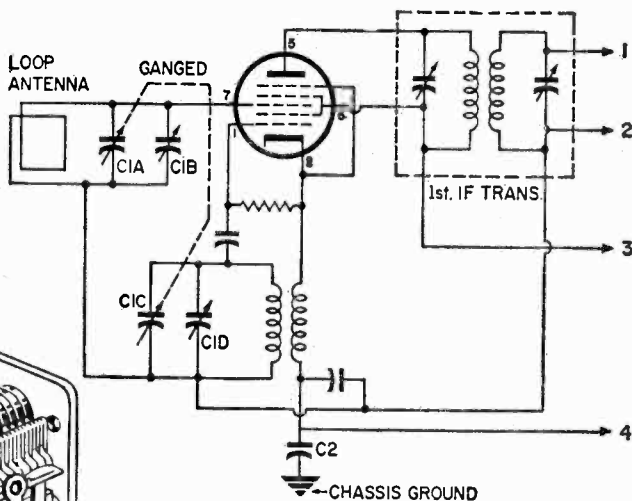
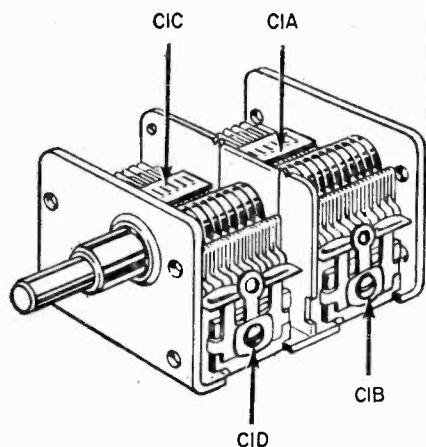

Fig. 2. Schematic diagram of superhet converter-oscillator shows the pentagrid converter.

Fig. 3. Ganged tuning capacitor C1A-C1C combines oscillator-RF tuning on one control.

tion of the oscillator frequency with the variation of the frequency of the resonant circuit in the RF section. The capacitors which tune the oscillator and the RF signal are actuated by one knob. Thus, when a specific station is selected by the RF section of the capacitor, the corresponding oscillator frequency is selected by the oscillator section of the capacitor.

The two signals are combined in the mixer stage. The output from this stage is the 455 kHz difference between the two signals. The 455 kHz difference in frequency is maintained between the oscillator and radio station; thus the difference frequency is available for all radio stations over the tuning range. It should be noted that the audio signal, which was received by the antenna as intelligence riding on top of the RF signal, is now transferred to the 455 kHz signal. It rides on top of this 455 kHz IF or *intermediate frequency* signal.

IF Amplifiers. This 455 kHz signal must now be amplified. The 455 kHz is carefully selected by two IF transformers. Between these two transformers is a stage of IF gain involving a vacuum tube or transistor. This

is not unlike a standard tuned RF stage, except here, only one frequency must be selected and only one frequency must be amplified. This can be done most efficiently.

In the remainder of the unit, the IF signal is detected to separate the audio from the IF carrier, the IF is discarded, the audio is amplified, and sent on to the speaker.

Why the choice of any specific IF frequency, is difficult to determine. It seems that 450 kHz or 500 kHz would be a more logical choice. Is there less interference or better sensitivity using 455 kHz? Or is it just a choice someone made and the number happened to stick? Whatever the reason, the industry has accepted this as the standard. We have no choice but to use this figure when aligning a radio.

Alignment Requirements. Although no outline of exact procedures has been described, the above discussion of the superheterodyne radio indicates the alignment requirements. There are two precise factors which must be satisfied.

First, the IF transformers must be aligned so that they will pass the 455 kHz IF frequency while rejecting all other signals.

Second, the variable capacitor must be adjusted so that the difference in frequency between the RF signal and oscillator is 455 kHz over the entire broadcast band.

Exact procedures using a signal generator and an output meter will be discussed below. However, before this is done, it would be helpful to discuss the circuit of a typical superheterodyne receiver. We will consider the receiver one stage at a time. If you would hook-up the leads (with arrowheads) represented by identical numbers in two successive stages (or two successive schematic figures), you have the schematic diagram of a complete superheterodyne receiver.

Typical 5-Tube Superhet. The first tube of the superhet (see Fig. 2) serves several functions. First, it is the oscillator—pins 1 and 2. Then, it receives the RF signal at pin 7. Finally, the two signals mix through the maze of grids to give the final IF frequency—455 kHz at the plate. The first IF transformer is tuned to this 455 kHz. Other RF frequencies that happen to get to the plate circuit are bypassed to ground via the power supply by the action of the 1st IF transformer.

Because these receivers are quite sensitive, the RF signal does not have to be picked up by an antenna on the roof. Instead, a loop antenna at the receiver is usually used. This may consist of several turns of wire on a flat piece of cardboard, or several turns of wire on a ferrite rod. The ferrite material is composed of iron and other metallic oxides combined with ceramic material for rigidity. This ferrite rod is also known as a loopstick.

The loop antenna works in conjunction with capacitor C1A (see Fig. 3) to form a resonant circuit to tune to the radio station. A small variable mica capacitor, C1B, is usually mounted on C1A and connected in parallel with it by the manufacturer of the capacitor. This C1B is used in the alignment procedure. It is known as a trimmer capacitor and is used to trim the combined values of C1A and C1B so that it will resonate at the proper frequency with the loop antenna coil, and at the proper setting of the tuning dial.

The oscillator coil, in junction with C1C and C1D form the resonant circuit to determine the frequency which the oscillator will generate. Capacitor C1C (see Fig. 3) is the main tuning capacitor for the oscillator, and C1D is the trimmer, arranged very

much like the combination discussed above for C1A and C1B in the RF section.

Capacitors C1A and C1C are attached to one shaft. One knob is used to turn both capacitors simultaneously. Screwdriver adjustment screws are set in the variable mica capacitors which are mounted on its respective large air capacitor.

You can usually tell which section of the capacitor refers to the oscillator and which to the RF circuit. The oscillator resonates at a higher frequency than does the RF circuit. Therefore the oscillator section usually has less or smaller plates than does the RF section. This is very much like musical instruments where higher pitched notes come from smaller instruments.

In Fig. 4, a simple IF amplifier stage using the 12BA6 and a second IF transformer, is shown. These are used to amplify the signal from the converter and first IF transformer and provide better selection of the IF frequency. These, in turn, are connected to the detector diodes in the 12AV6, the triode voltage amplifier in the 12AV6 and finally the power amplifier 50C5 which drives the speaker. All this is shown in Fig. 5.

The AC-DC power supply used to provide the necessary DC voltages to operate the radio circuit, is shown in Fig. 6, using a 35W4. Some radios used selenium or silicon rectifiers instead of a tube.

The various interconnections between sections are self-evident. Lead 1 is the link connecting the output from the IF transformer in Fig. 2 to the input of the IF amplifier tube in Fig. 4. Lead 3 in Fig. 2, 4, 5 and 6 is used to interconnect the B+ supply to all stages. Lead 4 in these figures is the common B- ground. (Turn page)

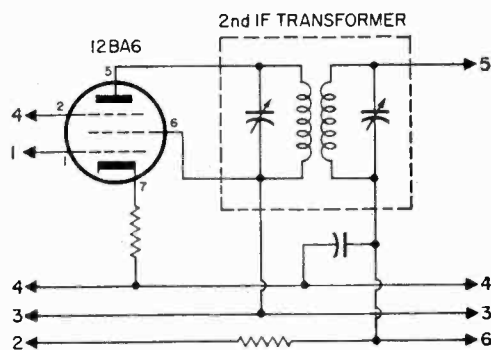

Fig. 4. IF amplifier tube 12BA6 boosts signal; second IF transformer increases selectivity.

Lead 5 in Figs. 4 and 5 connect the second IF transformer to the detector, while lead 6 connects the audio to the volume control through a resistor.

Introducing AVC. Only lead 2 requires some additional discussion. This lead is used to conduct part of the detected signal back, as DC, to the earlier stages. This DC controls the gain of these stages. On strong signals, the gain of the IF and mixer amplifiers is reduced due to this DC. Thus, this lead completes an Automatic Volume Control (AVC) circuit. It sort of equalizes the strength of the final output signal for all stations. In alignment procedures, AVC action is undesirable, for it limits variations in gain at the output. During alignment, the test signal levels are kept low so that AVC action will be negligible.

One other factor should be observed in this circuit. The chassis is not used as a ground for the B-. Because B- is connected to the AC line, grounding the chassis to B- and hence the AC line, can be hazardous. To keep the chassis from floating, it is connected to B- ground through a small capacitor. This is shown as C2 in Fig. 2.

Aligning Instruments. Two instruments are necessary in this procedure. One is to be used as a signal source. The second is to be used to measure the output.

In the alignment procedure, three signals should be used. An audio signal should be fed to the audio amplifier section of the receiver (Fig. 5) to be certain that it is operating.

Next, a 455 kHz signal modulated by an audio tone should be fed to the IF stages. The IF stages are adjusted for maximum

output by monitoring the audio signal strength at the speaker.

Finally, two modulated RF signals are required to permit adjustment of the RF and oscillator circuits. One RF signal must be at the high end of the band and the other RF signal must be at the low end of the band.

Several signal generators are available that are capable of producing all these signals. They are shown in the photograph in Fig. 7. The switch positions given in the following text are for the EICO 324 unit which is typical of the units available.

The audio output can be gotten from the two jacks at the lower left hand corner of the unit. The Signal Selector knob is to be set at the "Int. Mod/AF Out" position to get an internally modulated audio output. The "AF Mod/Output" control is used to adjust the amplitude or strength of the modulated audio signal output from the generator. None of the other controls have any effect on the audio. They are concerned only with the RF signal.

The connector at the lower right hand corner of the unit is used for the RF and IF output. The Signal Selector knob is set at its previous position for a modulated output signal. The frequency is selected by use of the Band Selector switch and the rotary frequency control knob. Thus if 455 kHz is required, the Band Selector is set at "B," for this band covers the range from 400 kHz to 1.2 MHz (marked near the tuning scales). The tuning knob is then rotated until 455 kHz appears under the pointer in the window. A similar procedure must be followed for any RF frequency that may be required.

The amount of RF signal output is controlled by the RF Course and RF Fine controls. These are usually kept near minimum during the alignment procedure.

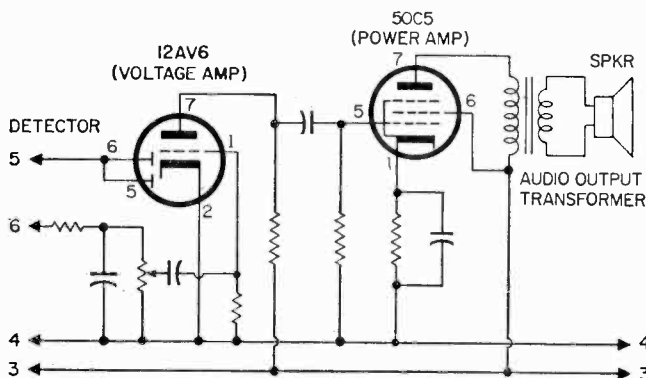

Fig. 5. The audio amplifier section of the receiver combines detection and voltage amplification in the 12AC6 tube, and power amplification in 50C5.

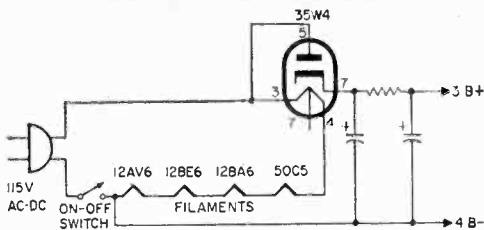

Fig. 6. The power supply that provides the DC voltages for receiver utilizes 35W4 diode tube in filtered half-wave rectifier circuit.

Finally, the output from the radio must be monitored in some way or other to perform a proper alignment. The low voltage AC scale on any multimeter can be used to measure the output voltage.

If no meter is available to monitor the output, the signal level may be checked audibly by listening to the speaker and judging the levels.

The Test Setup. When the receiver, generator, and meter are interconnected, details and precautions should be carefully observed.

The meter should be connected to the speaker leads in Fig. 6. If one of the speaker leads is connected to a chassis of B- ground, connect the common lead from the meter to this point. If you use the instrument illustrated, it is the lead with the alligator clip.

Connect the AC probe to the remaining lead to the speaker. If the speaker has no grounded leads, the meter may be connected in either direction. If you use a meter which does not have to be connected to the AC power supply, such as a VOM, the leads may be connected in either direction to the speaker.

Now set the Function switch on your meter so that it will read AC. Set the range switch to the lowest range above 1 volt. The output meter is now set up for the entire alignment procedure.

The common from the signal generator must be connected to the B- ground. During the alignment procedure, the signal will be injected from the Audio and RF outputs to various points in the radio. Just where to inject the signal will be discussed in the procedure methods.

Several precautions must be observed when making this setup.

1. Make all connections to the receiver when it is turned off.

2. Excess hum during test may be reduced by reversing the position of the AC power plug in its socket.

3. Never connect an external ground (radiator, water pipe, etc.) to any point on the receiver.

4. In conjunction with caution #3, never place the chassis on a metal bench, steam heat radiator, or any grounded object. If you must use a metal bench, be certain that the power plug is not in the socket or that there is some insulating material between the receiver with the instruments and the table. A large piece of cardboard will do. To avoid shock, do not touch the metal bench and the receiver or instruments simultaneously.

5. To avoid shock when aligning the unit, do not touch any grounded electrical conductors.

6. Use insulated or special aligning tools so that the alignment will not change when you remove the tool from the adjustment screws. A small insulated metal screw-driver may be used.

With this in mind, we can now proceed with the actual alignment procedure.

Aligning the IF's. Before touching the IF cans, you must be certain that the audio section is working properly. Connect the top (hot) lead from the audio output of the generator to the hot side of the volume control. This is the top, ungrounded end of the control in Fig. 5. Turn the volume control on the radio and the gain control on the generator to give the maximum output. Now, turn the output level control on your generator down until the sound comes through clean and undistorted to the ear. Note the voltage. During the remainder of the procedure, never let this meter read more than $\frac{1}{2}$ this voltage. If it should rise above this value, decrease the output from

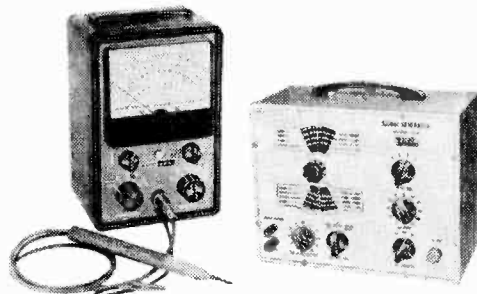

Fig. 7. VTVM and signal generator are all you need to align superheterodyne receivers.

the generator with the appropriate control.

Now set the generator to produce a modulated 455 kHz signal. Adjust the modulation control to less than 100% modulation. This is easy with most generators, since they are either not capable of this much modulation or use fixed modulation with no front panel controls.

Connect the RF output from the generator, through a .01 μ F capacitor, to the grid of the tube preceding the final IF transformer. In Fig. 4, it would be pin 1 of the 12BA6. Adjust the trimmers in the final IF transformer for the maximum output. Keep the oscillator output low enough so that the maximum desirable output voltage level, discussed above, will not be exceeded.

Now, connect the same probe to the RF grid of the converter stage. In Fig. 2, it is pin 7 of the 12BE6. Because of impedance conditions, the level of the output from the generator will probably have to be increased to get a reading on the meter. If no reading can still be made, it will be necessary to temporarily disconnect the tuned RF circuit. This tuned circuit consists of C1A, C1B and the loop antenna in Fig. 2. Now adjust the trimmers in the first IF transformer for the maximum output. Be certain to reconnect RF circuit after alignment is complete.

RF Alignment. The big problem with RF alignment is to find a convenient point at which to inject the RF signal.

If there is an antenna terminal, connect the output from the generator to it, through a capacitor. If there is no antenna terminal, as is the usual case, wind several turns of wire into a small coil or "hank." The size is only important in that it should be convenient to place it a few inches away from the flat loop or loopstick antenna, without shifting its position relative to the antenna. A small hank of four loops or turns of ordinary insulated hook-up wire wound in circles of about 3 inches in diameter will do nicely for this coil. The various turns can be held together at several points with masking tape. The masking tape can be used to hold it near the antenna during the alignment procedure.

If you made the RF loop discussed, disconnect both the RF and AF generator leads

from the chassis or B- ground. Connect the two leads from the hook-up wire loop to the RF leads from the generator. Should this loop stop the generator from oscillating (as noted by no output in the receiver) more turns will be required. Just how many turns can be found by trial and error.

If there is an antenna terminal on the receiver, do not disconnect the generator from ground, but connect the RF lead through a 200 μ F. capacitor to the antenna terminal.

Feed a 1400 kHz modulated signal to the receiver. Set the dial on the receiver to 1400 kHz. Adjust the oscillator trimmer condenser, C1D, for the maximum output.

Now feed a 600 kHz modulated signal to the receiver and set the dial on the radio to 600 kHz. Adjust the oscillator padder condenser,* if any, for maximum output. If there is no padder condenser, there is usually a screwdriver adjustable slug in the oscillator coil. Adjust this for maximum output.

Next, recheck the 1400 kHz adjustment. Repeat both adjustments (the one at 1400 kHz and the one at 600 kHz) until you get the maximum output and best tracking.

Now that the oscillator section has been adjusted, the RF circuit must be adjusted. Once again, feed a 1400 kHz modulated signal to the receiver. Tune the radio to 1400 kHz. Adjust the RF trimmer condenser (C1B in Fig. 2) for maximum output.

Next, feed the 600 kHz signal to the receiver and set the dial to 600 kHz. Adjust the padder condenser or slug in the antenna coil, if either exists. In some units, it is possible to adjust the position of the coin on the loopstick for maximum output signal. In other units, where no padder facilities exist, the trimmer must be adjusted to give the best maximum output compromise at 600 kHz and 1400 kHz.

If your listening habits favor one end of the band over the other, or one station more than another, it is best to adjust the RF trimmer for the maximum output at the frequency of the favored station.

Repeat the RF alignments at 1400 kHz and 600 kHz until the best compromise is achieved. Alignment is complete when you remove the leads from the signal generator and the RF coil you made. ■

* Some receivers have a capacitor between the parallel combination of C1C-C1D and the oscillator coil. This is the padder condenser. A padder condenser may be placed in a similar position in the RF circuit.

NEW LIFE FOR OLD TUNERS

TOUCH-UP + TUNE-UP = AN FM TUNER THAT PLAYS LIKE NEW

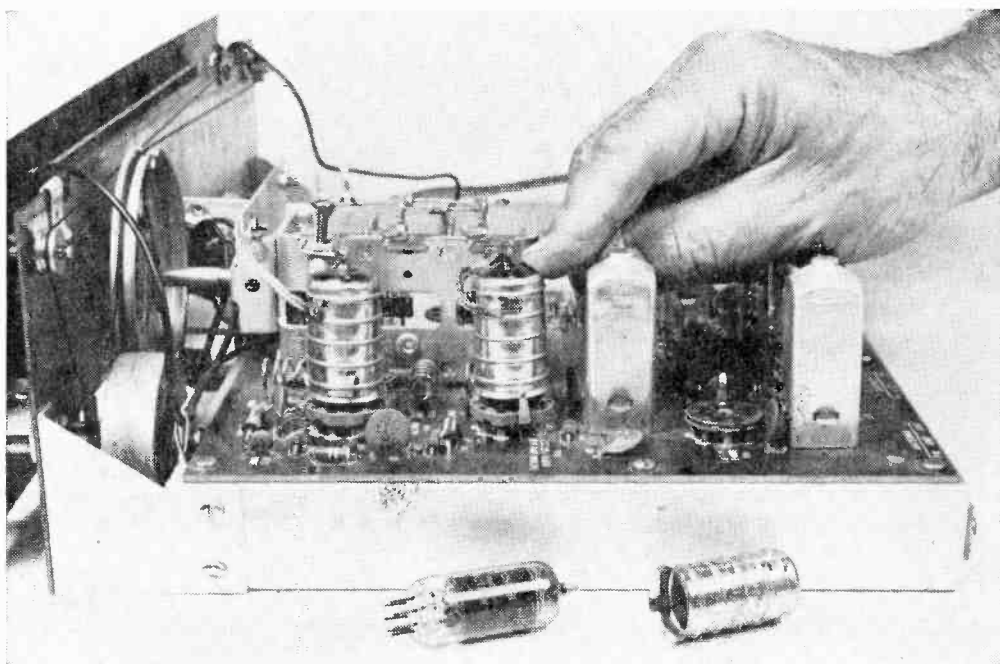

BY H. B. MORRIS

☒ To borrow a phrase from one old-time technician: "I'd rather fix a dead FM tuner than one that plays a little bit." It makes sense. Most inoperative sets have just one bad part. But a circuit that just won't sound right can make a repairman wish he'd stuck to plumbing. That kind of trouble can be general debility—not one bad part, but an adding up of many minor defects. If your tuner is more than three or four years old, chances are it's beginning to develop the

symptoms. And you may not even hear it.

The process is actually so slow that loss of quality is not immediately apparent. In fact, you may not have the slightest inkling that anything is wrong—until you go to a hi-fi show or dealer and hear once again what quality FM can really sound like.

Since the problem is a general one, the solution, too, is general. The tuner is probably ready for a good going-over. Some parts, in fact, can be renewed even when they

seem trouble-free. Take the case of an aging RF amplifier.

Vacuum Tubes. Most of the tuner's sensitivity—the ability to amplify a signal and not the noise—is determined in the front-end section. The big burden falls on the RF amplifier tube. When it ages, noise usually begins to creep up. Weaker stations are not received as well as when the tuner was new. And to compound the problem, such tubes usually check OK on a tube tester. So to head off problems in the front end, it's a good idea to replace the RF amplifier tube at least every two years, even though it seems to perform satisfactorily.

Another touchy tube also occurs in the front end. It's the local oscillator. One clue to a declining tube in this section is drift; the tuner requires returning one or more times after it's turned on. This could be caused by shifting element spacing within the tube and consequent changes in oscillator frequency. A fresh tube can eliminate this annoying inconvenience.

Other tubes in the FM tuner tend to be less critical since they handle lower frequencies. Yet they have their share of troubles. Consider IF tubes in the intermediate-frequency amplifier. They are especially subject to microphonics, a condition where loose tube elements vibrate and introduce false signals. You can check this by tapping the tube with an eraser and listening for a ringing sound in the loudspeaker. Another tube difficulty is a high-resistance short which develops between elements: this may not actually disable the tuner, but it may be troublesome enough to introduce hum or distortion.

These tube troubles may not show up on a tube checker—especially the corner drug-store type. Unless you have access to a high-quality checker (transconductance type) the most effective method is tube substitution. With a set of new tubes on hand, it is a simple matter to check each major stage in the receiver. Note carefully the difference in performance as each tube is replaced. You may detect small changes in hum level, hiss or sound quality. Vacuum tubes are responsible for more than about 80 percent of all tuner trouble.

Mechanical. The tuner, essentially an electronic device, is also mechanical. Whenever

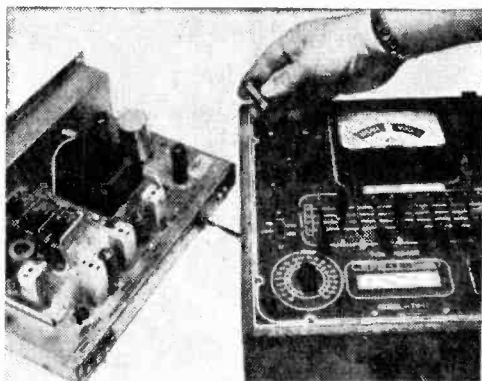

Always check out vacuum tubes first, since roughly 80-percent of tuner troubles can be attributed to tubes. As mentioned in text, tube troubles are often indicated by specific symptoms in quality of audio performance.

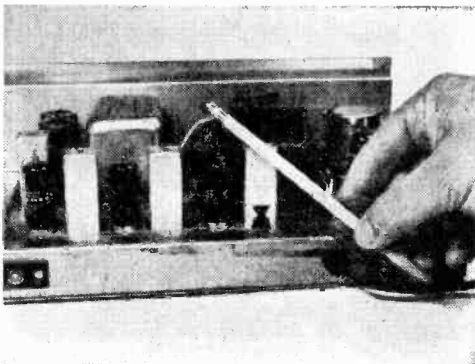

Loose elements in a tube cause microphonics and can actually sound like a concert of electronic music when you tap the faulty tube with your finger or the eraser end of a lead pencil.

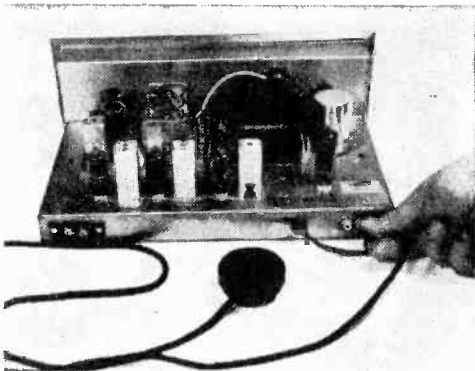

If you don't have an amplifier and speaker, connect a headphone to the audio output jack of the tuner to monitor the audio signal.

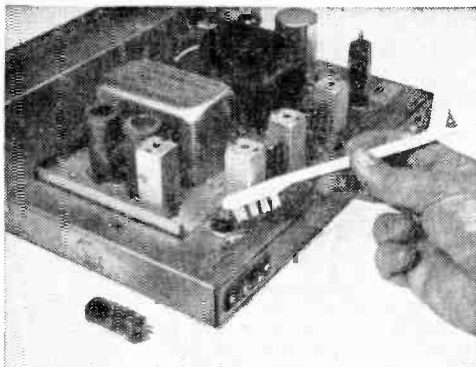

You'll wonder where the leakage went when you brush the tops and bottoms of your tube sockets with tuner cleaner. Don't forget to clean and tidy up that smudged tuning dial.

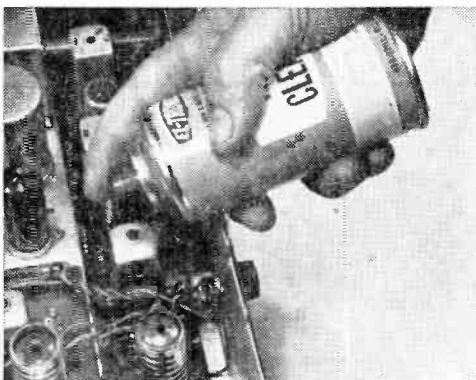

Spray tuner cleaner into switches and controls to renew surfaces and re-establish contact. Remember the tuning capacitor: movable plates (i.e., the rotor section) often lose contact because of dirt; the result is erratic performance.

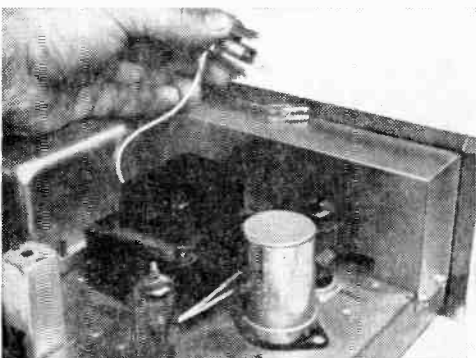

The job of replacing burned-out dial lamps often prompts a complete tuner overhaul. Be certain to purchase bulbs with the same type number and with beads of the same color.

the two are mixed there's bound to be trouble. Mechanical failure produces scratching noise while changing stations, sizzling sounds when the volume control is adjusted . . . or strange cases of intermittent signals due to defective audio plugs and sockets. Here's a case history of what to expect from a tuner that's getting on in years.

One of the tuners shown in the photos developed a classic symptom: several stations could be tuned in smoothly, some signals seemed to pop into place, others just couldn't be latched in. A sputtering sound in the loudspeaker made the rig sound like it had sawdust in its transmission. Since this mainly happened as the tuning dial was rotated, it looked like a case of poor grounds in the tuning capacitor. If you closely examine a variable capacitor you'll see several pieces of springy brass (yellowish in color) soldered to the capacitor frame. They also push against the turning shaft of the capacitor. This insures that the moving plates of the capacitor are always firmly grounded. But spring action may wane, or dirt may work itself in. It sets up an electrical racket and tuning becomes tricky.

The remedy isn't difficult. Use a cleaner-lubricant (such as GC's Lube-Rex) and introduce a small amount into the various mating surfaces between the brass springs and shaft. Let it work in by rotating the tuning dial several times over its complete range. The result can be surprising, like-new smoothness in tuning. Some tuners, incidentally, shield the tuning capacitor with a metal can. This is usually removable by a few screws. Just be careful not to bump the capacitor plates when working in this area.

Another candidate for cleanup is the volume control found on most tuners. After a few years, dirt enters and causes sizzling noise when the control is turned. It can cause some strange effects, too. Old volume controls have been known to change sound level as someone walks across the room. They can also cause hum. These effects usually occur as the sliding element within the control loses some tension or fails to make good contact. These troubles are almost always cured by squirting some cleaner spray into a hole on the body of the control or in the opening around the solder lugs. With these steps completed—all controls cleaned and lubricated—consider the next major step.

Visual Inspection. Peer into the wiring

under the tuner chassis and you may spot trouble, even with no other test instruments than your eye and nose. Use a bright light source, like a lamp next to the chassis. Examine all capacitors. Several might appear to be damaged, with large blobs of matter oozing from their insides. Don't be deceived by this symptom and automatically replace these parts. If the leaking material is ordinary wax, it is normal for this material to sag due to heat developed during tuner operation. The function of wax is to seal the capacitor against moisture. But despite some flow, there is no serious problem. Usually these capacitors are tubular or paper type

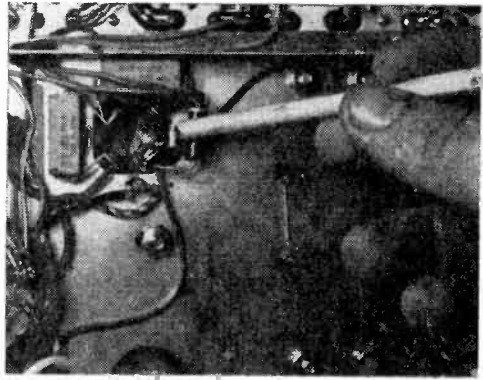

When visually checking the tuner chassis, inspect the lugs around the electrolytic capacitor for a powdery substance which collects if the capacitor has been leaking. It'll pay to check out a suspect capacitor with a VTVM.

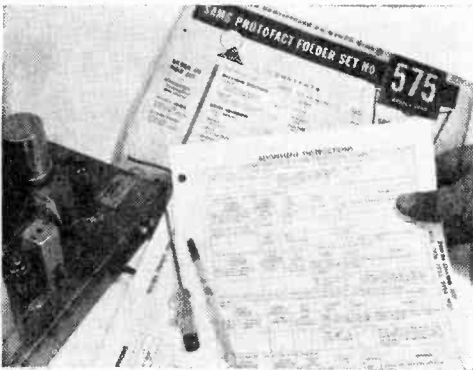
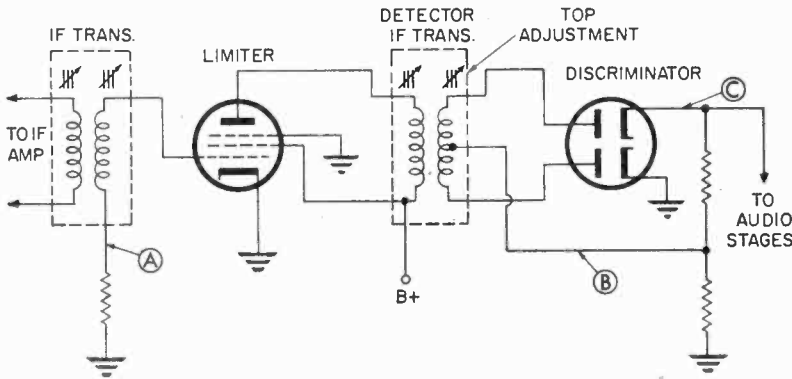

If your FM tuner was built from a kit, you have important alignment information in your booklet; otherwise, get a Sams Photofact folder.

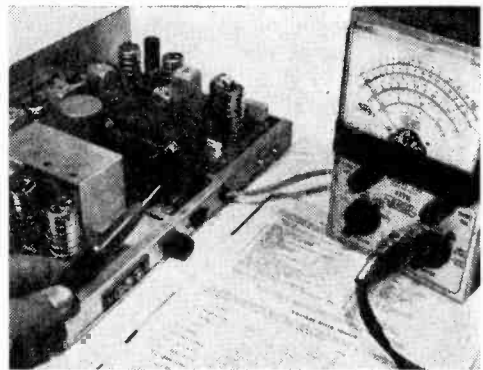

Your tuner voltage, resistance, and alignment measurements should be taken with a vacuum tube voltmeter. This instrument is an EICO.

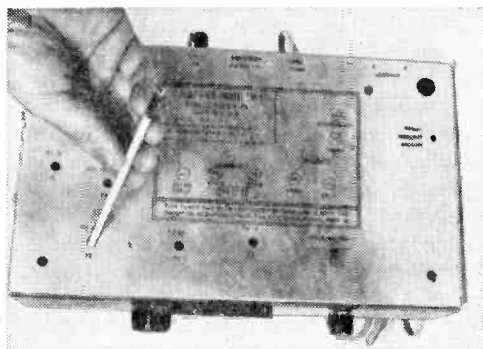

On most tuners IF alignment is made from tops of IF cans, but on some, such as one shown here, alignment is made through holes in bottom plate. If identification marks are beginning to fade, retouch them with lacquer.

and may be left alone; the excess wax won't short-circuit other parts.

But if you're looking at a large electrolytic capacitor, especially the type mounted in a metal can, leakage could be a sign of trouble. Here the material pushed out of the capacitor appears powdery and collects around the solder lugs. Whether the capacitor needs replacement must be determined by checks described later. But if you're a purist—the kind who wants quality at any price—you can install a new electrolytic, say every three years. After tubes, these components tend to be the most cantankerous. In the aging process, their filtering action may drop somewhat and introduce increasing hum. Also they can cause motor-boating; a slow kind of oscillation which produces a put-put sound, especially when the bass control is turned full on. Another

Drawing 1. Schematic diagram of typical limiter-discriminator shows the alignment points at which voltage measurements are taken (left). VTVM is used to make measurements.

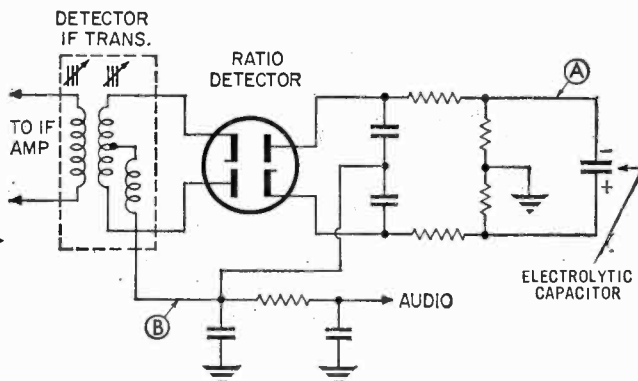

Drawing 2. Detector alignment points for typical ratio detector circuit (right). All IF transformers except top of detector transformer are tuned for a maximum negative DC at point A.

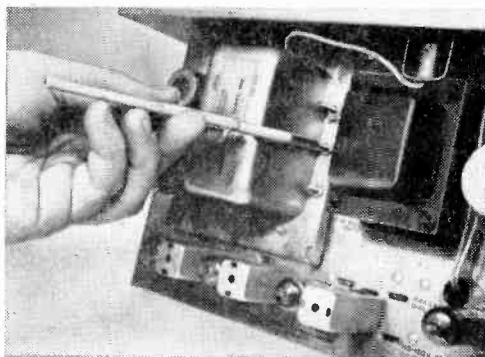

Alignment of RF amplifier, mixer, and local oscillator is not normally required, but when necessary, an RF signal generator is a must.

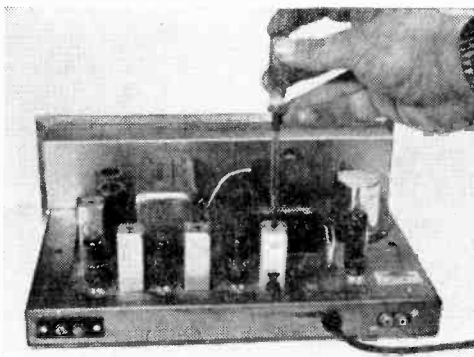

Fragile transformer cores should be adjusted only with proper alignment tool. Use of a screwdriver may cause irreparable damage.

problem of old electrolytics: their internal resistance may drop and impose a drain on the power supply, thereby lowering the B+ voltage supply to the rest of the tubes' plate circuits.

Your eye, with an assist from the nose, can spot charred or blackened components, usually resistors which have become overheated. Again don't be misled by the first glance. Underchassis parts frequently become blackened due to air currents set up by the hot tubes. As air is drawn into the chassis, air-borne grease and dust ride in too and coat the components. So before changing any blackened component, first wipe it off with a cloth. If the material is actually charred and flakes off, it requires replacement.

Circuit Checks. To continue the reviving process in an FM tuner more than human senses is needed. Required is a vacuum-tube voltmeter (VTVM). With this instrument, it is possible to run a fast check of all key test points in the circuit. This is a revealing step. You may run into circuit values which are completely wrong—but fail to produce a dead tuner. Rather, they rob the circuit of full performance capability. The few minutes spent making these measurements are well worth it.

Virtually no significant meter readings

can be taken without good service information. If yours is a kit-type tuner, chances are that such data is provided in the instruction manual. Some factory-wired tuners come with an operator's manual which may also contain technical information. Another possibility is writing to the manufacturer for the tuner's service manual. Finally, you can choose the route taken by a large number of servicemen; purchasing service literature designed for troubleshooting the particular tuner model. Such information, for example, is offered in *Photofact* folders, which provide a great amount of detail; parts identification, circuit values and alignment information. They are available through mail-order catalogs or at local electronic distributors.

Start with resistance checks at all tube-socket pins using the resistance chart provided. These readings are taken with the tuner off and unplugged from the AC wall outlet. Occasionally there will be a resistance reading which is considerably off the recommended value. This could be due to capacitors which retain their charge and influence the meter reading. The remedy is to take an insulated screwdriver and short the capacitor to ground.

If all resistances are OK, run a voltage check on all recommended test points. In some cases, voltages are supplied in chart form, in others they are marked directly on the schematic. Don't overlook special precautions to be observed during voltage checks. Some manufacturers, for example, state that voltages must be within 15%, how

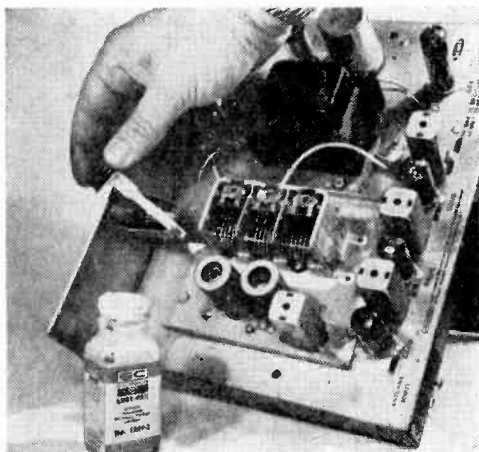

GC Electronics' *Lube Rex* is a specially formulated lubricant for re-establishing contact between tuning capacitor plates and ground.

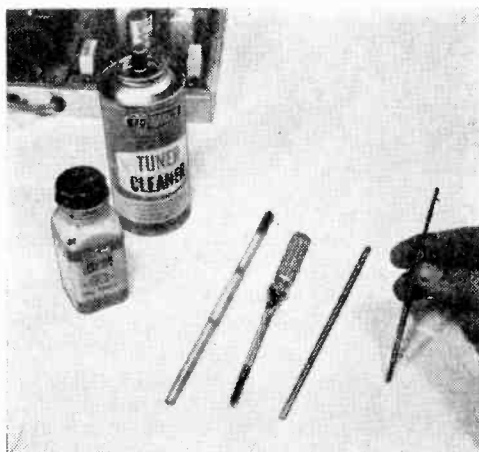

Among the things you'll need before starting the job are a selection of proper alignment tools, contact lubricant, and tuner cleaner.

the volume control is set, whether a station is tuned in, etc. These factors affect meter readings.

Alignment. In general, tuners tend to stay in alignment for long periods of time. Unless a coil or transformer has been changed, only slight touch-up of adjustments is in order. You'll need at least two items before attempting the job: the alignment procedure given in the service literature and appropriate tuning tools. These last items are important. The right tool not only speeds the job, but prevents damage to such fragile components as cores inside transformers (which usually powder when turned by a regular screwdriver). Depending on the specific tuner, you'll need either a hex-type plastic tuning rod or a broad-tip, insulated screwdriver made especially for IF transformers. These requirements are frequently given in service literature or you can shine a light into the transformer cans to see the shape of the core. Although specific instructions should be followed, let's consider some general aspects of alignment.

Part of the job can be done without instruments if the tuner has a tuning meter or magic eye. Tune in a station which is only moderately strong (one that doesn't deflect the tuning meter all the way or completely close the tuning eye). Many FM tuners have four or five IF transformers. Locate the one next to the detector stage (farthest from the front end, or tuning section, of the tuner). Adjust the *primary* core of the detector transformer—which is generally the *top* adjustment—for maximum signal on the tuning indicator. Then proceed to the top and bottom adjustments of all remaining transformers, working your way toward the front end of the set. Only slight adjustments should be necessary. It's also important not to touch the tuning dial during any of these adjustments.

Now return to the detector transformer and its top, or secondary, adjustment. You'll have to connect an amplifier during this procedure so sound quality can be monitored by ear. Carefully adjust the top core for least distortion and hum.

If the tuner has no built-in tuning indicator, a VTVM is used for IF alignment. Shown in Drawing 1 is a simplified schematic diagram of a limiter stage used in FM receivers having a discriminator-type detector. The VTVM is set up to read low negative DC voltage at point A shown in the diagram. The IF transformer cores (except for the top

and bottom of the detector transformer) are adjusted for maximum negative voltage. Next place a 1-megohm resistor in series with the negative probe and touch it to point B. The bottom of the detector transformer is tuned for maximum reading. The final step is adjusting the VTVM so it reads at zero-center (usually done by placing its function switch on negative and setting the needle at center scale with the zero adjust). Place the VTVM probe at point C. Adjust the top of the detector transformer for zero volts. It's important to observe the following during this adjustment: while the top core is adjusted, the meter needle must swing through positive and negative on either side of zero.

If your tuner has a ratio detector, like the circuit shown in Drawing 2, alignment points are slightly different. Tune all transformers for maximum negative DC at point A, except the top of the detector transformer. Shift the VTVM to point B and tune the top of the detector transformer for zero volts, using the zero-center technique described above for the discriminator circuit.

The only remaining area of alignment is the tuner front end; RF amplifier, mixer and local oscillator. Since they operate at extremely high frequencies it is best not to attempt alignment without a signal generator.

As a final step for reviving an FM tuner, recheck the antenna. Any improvement here can pay off handsomely. The antenna system should be in perfect condition from the tuner terminals to the top of the mast. If a separate FM antenna is not used, a coupling transformer tapped into the twinlead of a TV antenna can also produce good results; perhaps even pulling in a couple of more FM stations from distant points. ■

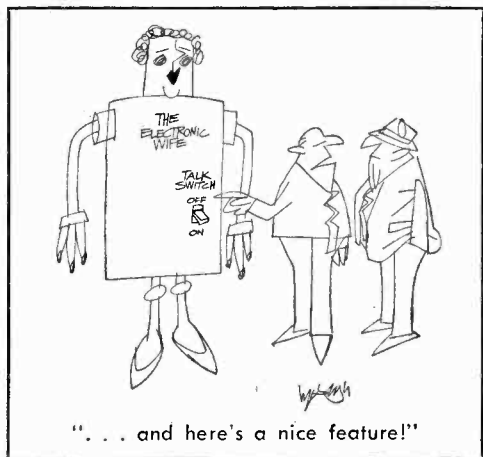

You get more for your money from NRI—

America's oldest and largest Electronic, Radio-Television home-study school

Compare. You'll find—as have so many thousands of others—NRI training can't be beat. From the delivery of your first lessons in the remarkable, new Achievement Kit, to "bite size," easily-read texts and carefully designed training equipment . . . NRI gives you more value.

Shown below is a dramatic, pictorial example of training materials in *just one* NRI Course. Everything you see below is included in low-cost NRI training. Other major NRI courses are equally complete. Text for text, kit for kit, dollar for dollar—your best home-study buy is NRI.

All this is yours—from Achievement Kit to the only Color TV specifically designed for training—when you enroll for NRI's TV-Radio Servicing course. Other courses are equally complete. But NRI training is more than kits and "bite-size" texts. It's also personal services which have made NRI a 50 year leader in the home-study field. Mail the postage-free card today.

Approved under GI BILL

If you served since Jan. 31, 1955, or are in service, check GI line in postage-free card.



NEW! *Learn Color TV
servicing as you build a
custom* **COLOR TV**



**NRI INTRODUCES THE
ONLY COLOR TV TOTALLY
ENGINEERED FOR TRAINING!**

**Fill in Postage-Free Card
and Mail Now!**

SEE OTHER SIDE

**NOW 12 WAYS TO
TRAIN AT HOME**

Mail this postage-free card



**NATIONAL RADIO
INSTITUTE**
Washington, D.C. 20016

Please send me your new catalog. I have checked the field(s) of most interest to me. (No salesman will call. Please PRINT.)

- | | |
|---|---|
| <input type="checkbox"/> TV-Radio Servicing
(with color) | <input type="checkbox"/> Basic Electronics |
| <input type="checkbox"/> Advanced Color TV | <input type="checkbox"/> Electronics for
Automation |
| <input type="checkbox"/> Industrial Electronics | <input type="checkbox"/> Aviation
Communications |
| <input type="checkbox"/> Complete
Communications | <input type="checkbox"/> Marine Communications |
| <input type="checkbox"/> FCC License | <input type="checkbox"/> Mobile Communications |
| <input type="checkbox"/> Math for Electronics | <input type="checkbox"/> Electrical Appliance
Repair |

Check for facts on new GI bill

8-097

Name _____ Age _____

Address _____

City _____ State _____ Zip
Code _____

ACCREDITED MEMBER NATIONAL HOME STUDY COUNCIL





NO POSTAGE NECESSARY IF MAILED IN THE UNITED STATES

BUSINESS REPLY MAIL

POSTAGE WILL BE PAID BY

NATIONAL RADIO INSTITUTE

3939 Wisconsin Avenue

Washington, D. C. 20016

FIRST CLASS
PERMIT
No. 20-R
Washington, D. C.

NEW COLOR CATALOG FREE—

Gives full details about
new NRI Color TV Servicing
and 11 other training plans

EARN YOUR
FCC LICENSE
...OR YOUR
MONEY BACK
ON ALL
COMMUNICATIONS COURSES



MAIL CARD NOW

NO POSTAGE NEEDED

SEE OTHER SIDE

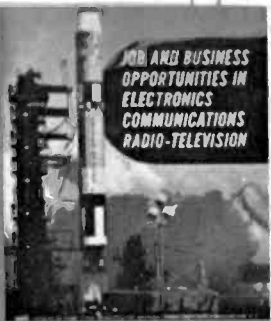

JOB AND BUSINESS
OPPORTUNITIES IN
ELECTRONICS
COMMUNICATIONS
RADIO-TELEVISION



GET A FASTER START WITH NRI'S NEW EXCLUSIVE ACHIEVEMENT KIT

The day your enrollment is received your Achievement Kit will be on its way to you. It contains everything you need to make an easy, fast start in the Electronics training of your choice. This attractive, new starter kit is an outstanding, logical way to introduce you to home-study the way NRI teaches it . . . backed by a dedicated staff and the personal attention you should expect of a home-study school. It is your first special training aid . . . designed to make your adventure into Electronics absorbing, meaningful. Your Achievement Kit contains your first group of lesson texts; rich vinyl desk folder to hold study material; the industry's most complete Radio-TV Electronics Dictionary; valuable reference texts; lesson answer sheets; envelopes; pencils, pen; engineer's ruler—even postage. No other school has anything like it.

OVER 50 YEARS OF LEADERSHIP



LEARNING BECOMES AN ABSORBING ADVENTURE WITH NRI TRAINING KITS

What better way to learn than by doing? NRI pioneered and perfected the "home lab" technique of learning at home in your spare time. You get your hands on actual parts and use them to build, experiment, explore, discover. Electronics come alive! NRI invites comparison with training equipment offered by any other school. Begin NOW this exciting, practical program. It's the best way to understand the skills of the finest technicians—and make their techniques your own. Whatever your reason for wanting to increase your knowledge of Electronics . . . whatever your field of interest . . . whatever your education . . . there's an NRI instruction plan for you, at low tuition rates to fit your budget. Get all the facts about NRI training plans, NRI training equipment. Fill in and mail the attached postage-free card today.

NATIONAL RADIO INSTITUTE, Washington, D.C. 20016.

IN ELECTRONICS TRAINING

Accredited by the Accrediting Commission of the National Home Study Council

NEW COLOR TV

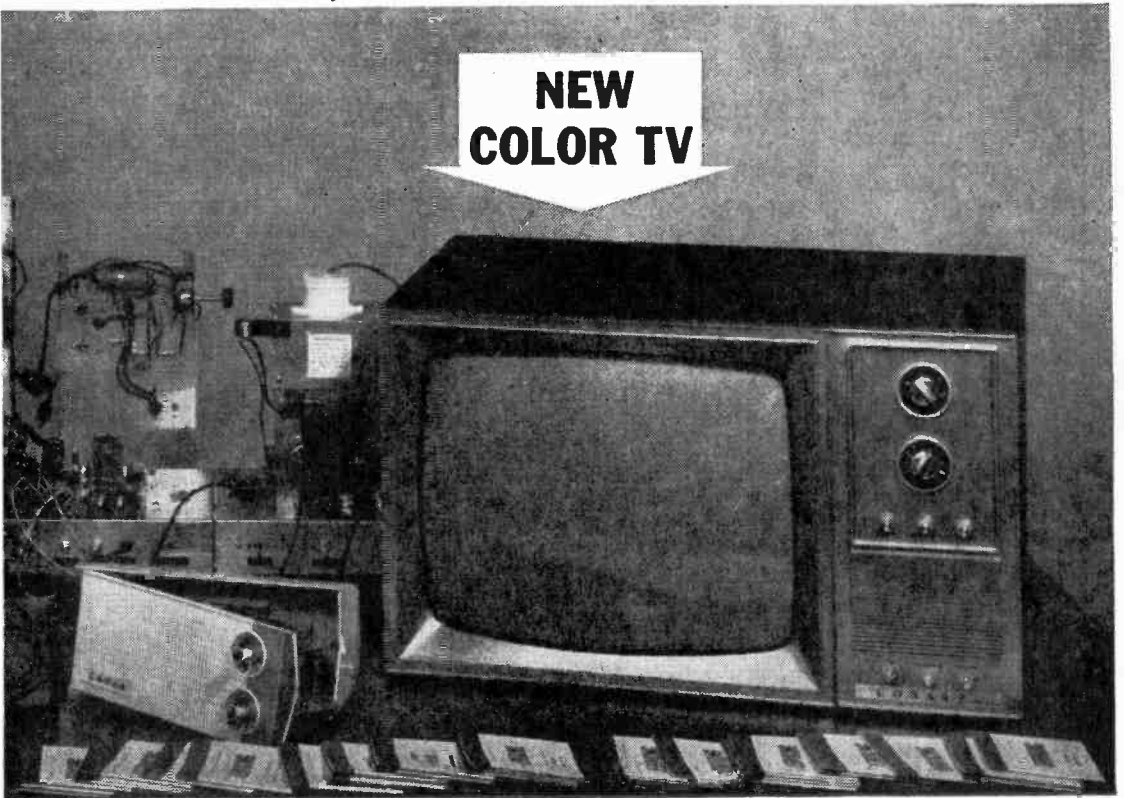

TV BUZZ

By Jack Townsend

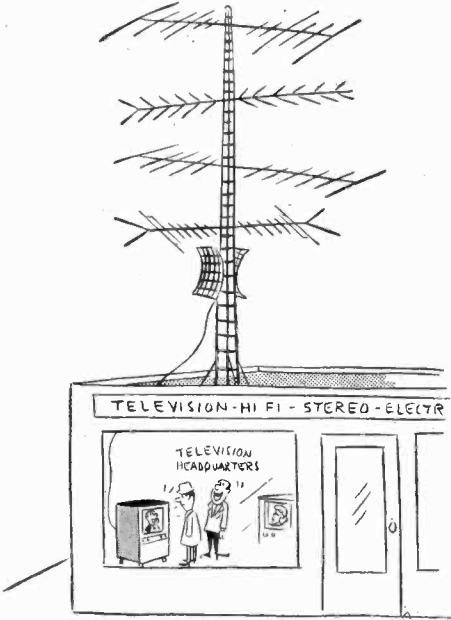

"Of course the picture will be lots clearer with an outside antenna."



"!awen tɹɔpɹɔ ɛrɪt ɹɔt wɔn bɪs . . ."



TV REPAIR



So You Want To Replace a Boob Tube

By LEN BUCKWALTER

Can anyone change a picture tube? Not the yank-'n pull mechanic; he could fudge the job. The careful worker, however, can reap a double reward; a husky saving in cash and the satisfaction of restoring a good-as-new picture to an aging TV set. Success doesn't depend on an intimate knowledge of electronics. There are few mysteries surrounding the removal and re-installation of the picture tube. The big factor is a healthy respect an installer must have for the tube. Fragile glass construction can't tolerate rough handling. So if you're willing to handle the TV picture tube with loving care—avoiding

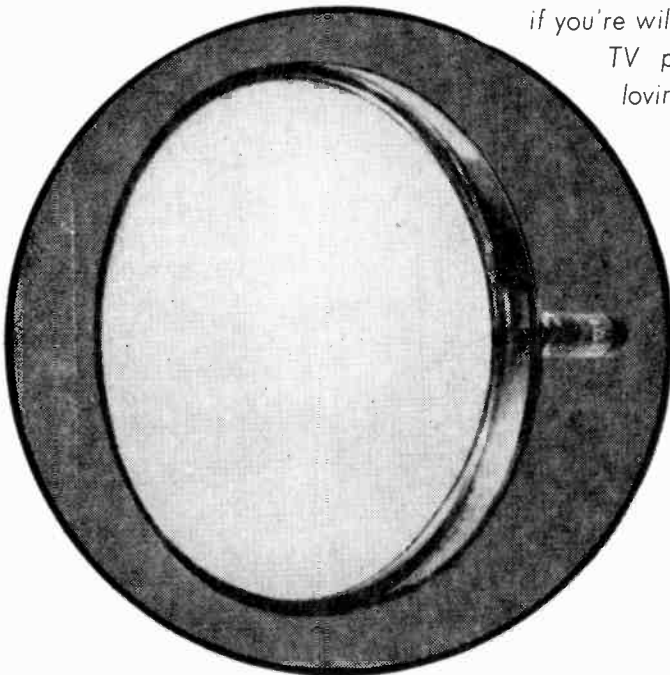

REPLACE BOOB TUBE

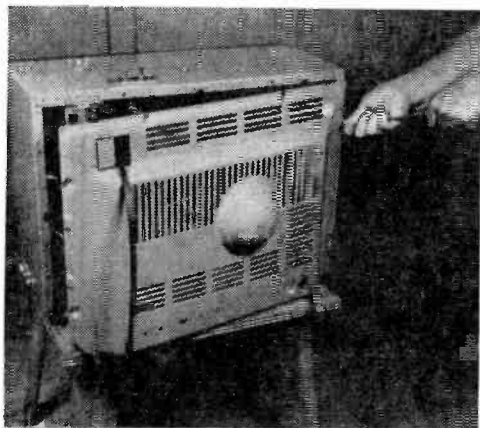

Removing back cover of TV is first step in replacing picture tube. AC cord, interlocked to back cover (lower right), comes off with it.

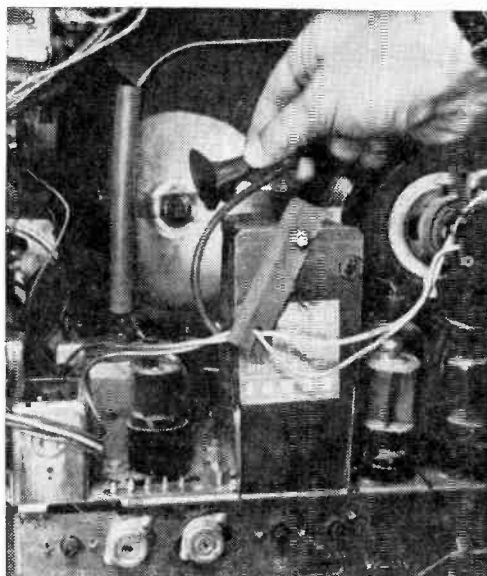

Carefully remove rubber anode cap plugged into the side of the picture tube by simply pulling or, if a clip type, by squeezing.

Short circuit the anode cap against chassis several times to dissipate any charges that might be present.

accidental strain, bumps or scratches—the job shouldn't prove too difficult.

Is the tube really at fault? This is a crucial first question. It's a crushing experience, as some have learned, to buy and install a picture tube—only to find the old trouble pop up on the new screen. Some faults give the exact same symptoms as a bad picture tube. So pinpoint the culprit.

Complete Loss of Brightness. The picture tube needs high voltage to produce brightness. Check for this voltage by finding the anode cap shown in the step-by-step photos. With power turned off, unplug the cap from the side of the tube (grasping only the rubber part). Now tape the cap so it sits about a quarter or half-inch away from its socket. Move away and turn on the power. If high voltage is present, you'll see and hear it; a blue spark should jump the gap and produce a sputtering, crackling sound. Some small chassis tubes which can kill high voltage are the horizontal oscillator, horizontal amplifier, high-voltage rectifier or damper. A blown high-voltage fuse is also a possibility. These items may be identified by the diagram pasted inside the set's cabinet or with the aid of a schematic. If these stages are causing high-voltage trouble, a new picture tube won't work.

Gradual Loss of Brightness. If this occurs over a long period, it's a good sign of a failing picture tube. You can milk additional months of service with a booster, but this is only a delaying action. Another possibility is the build-up of dirt on the screen (high voltage attracts dust like a magnet). In some sets, it can be cleaned from the front of the set if the manufacturer has provided a re-

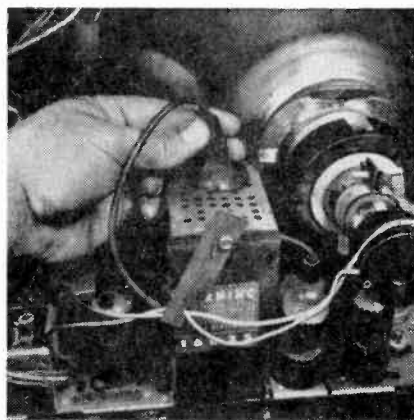

movable safety glass. Otherwise, the tube must be removed to gain access to the screen surface. (If you have a late-model set with a bonded safety glass, usually stated in the advertising literature, dirt can't accumulate inside.) In any case, a good cleaning of the screen surface in older sets can yield a remarkable increase in brightness, especially if there's more than one year's accumulation.

The darkening screen, however, which inevitably occurs some two or more years after the set is purchased, spells decreasing emission from the tube's electron gun. A good clue to this condition is the length of time it takes for the set to warm up and produce a usable picture. Low-emission tubes take two or three times longer to heat than when the set was new.

Other clues. Turning the brightness control has no effect; the picture stays bright. This is an excellent sign of a shorted grid in the picture tube. Such tubes deserve replacement, but there are two tricks for delaying the job. One is to purchase a special picture-tube booster which also can isolate the shorted grid. (It works only in some cases.) The other is a hit-or-miss method which might produce results, for a while anyway. Very gently tap the neck of the tube with the end of a pencil. This could dislodge the shorted element and unshort it.

Another valuable sign of a bad picture tube occurs when the picture goes negative; that is, blacks reverse to whites. This is caused by air seepage into the tube, molecule by molecule, over a long period of time. Such "gassy" tubes should be replaced. One misleading symptom is picture "blooming." As the brightness control is turned up to a nor-

mal position, the whole image expands like an inflated balloon. Image brightness dims as the picture grows in size. This is not caused by a bad picture tube. In nearly every case the reason is a bad high voltage rectifier, a small tube which is unable to keep high voltage up as electron-beam current rises to create more brightness.

Filament. Many people will tolerate a dimming image as the picture tube ages, but few will accept the condition which causes most outright failures. It is the burned-out filament. Investigating a dead filament should begin at the picture-tube neck. With the power on, a dull orange glow should be seen near the end of the neck, next to the socket. One exception may occur in the series-filament set, one without a power transformer. A burned-out filament in any of several small tubes could also cause the picture-tube filament to darken. Thus, dark or cold tubes in the series set must be checked individually before assuming that the trouble lies in the picture tube filament.

Occasionally, a picture-tube filament grows dark due to a mechanical fault in the socket, usually a loss of tension in the spring clips which grasp the tube pins. This may be detected by applying gently pressure to the socket, in all directions, and observing if the tube filament lights during any of these movements. If so, a new socket can be wired into place.

The professional installer usually makes a direct measurement of the filament to verify failure. One method is with an ohmmeter touched to the picture tube pins (after the socket is removed). An unbroken filament reads a few ohms resistance. Most tubes

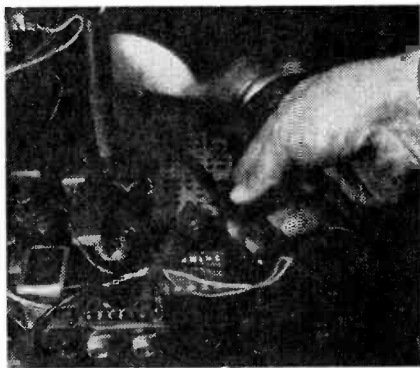

Short circuit voltage stored in picture tube by touching insulated screwdriver to anode and chassis a few times.

Now remove the picture tube socket from the tube pins at the base of the neck. A slight rocking action will probably be necessary.

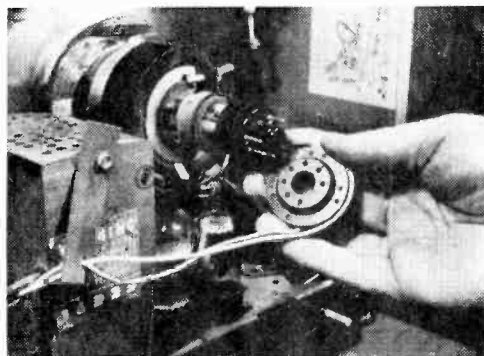

REPLACE BOOB TUBE



First loosen wing nut, then slide off yoke clamp. (In many sets this will be ion-trap magnet held by a spring around tube neck.)

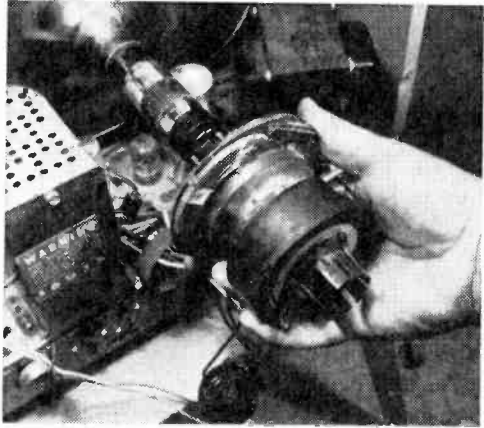

Slide off yoke and centering magnet assembly (usually in one piece). If a yoke clamp isn't used, loosen the wing nut on top of the yoke.

use one of the following filament-pin combinations: 1-8; 1-12; 3-4; or 4-5.

After you've determined that the picture tube is bad, the next consideration is the type of replacement to purchase. Unless you have a private pipeline to one of the big producers, you cannot get a *new* TV picture tube. All TV replacement tubes are rebuilt. This may imply a compromise in quality. Not so in

most cases. Only the glass envelope is reused in the rebuilt tube; screen and electron gun are new. Yet, there is still a range in price. If a budget-priced rebuilt is purchased, it could run nearly half the cost of a rebuilt from a big-name producer—GE, RCA, etc. In this writer's experience, the budget-price rebuilds are economically attractive, but in numerous cases have failed to maintain proper emission (and therefore brightness) much beyond the 1-year guarantee period. It could be due to poor quality control by some small rebuilding houses. The choice is left to the buyer. Whatever the purchase, a replacement containing an aluminized screen, if available in your number, is highly recommended. The difference in tube performance is considerable; light is not wasted in the rear end of the tube, but reflected back to the viewer's eye.

Removal. The precautions shown for discharging high voltage retained by the tube

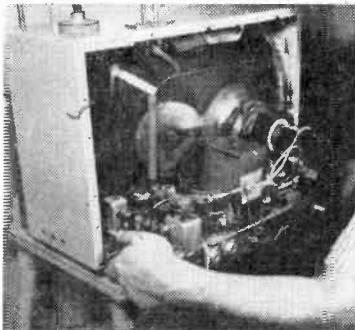

In this set, tube and chassis are removed together. When this is the case, make sure the tube face isn't held by cabinet.

Remove mounting hardware from all around the front rim of the tube. Be sure to retain all clamps, screws.



If it's necessary to remove chassis from cabinet (see text), remove all of the control knobs from the set first.

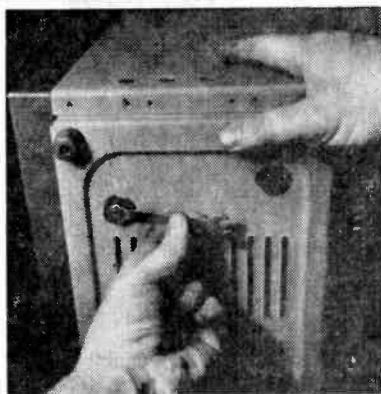
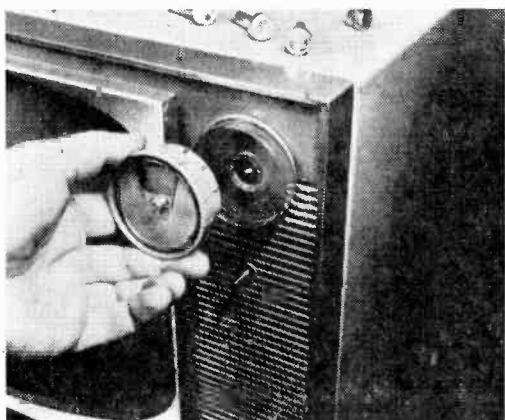

Chassis is usually secured to cabinet (shown here tilted) with bolts. Keep cabinet level when loosening.

are mainly intended for protecting against breakage. The charge is not electrically dangerous. Rather, it may cause a person to jump back or jerk his arm while holding the tube, and thereby dropping it. Be sure to discharge the tube repeatedly for about a minute to get rid of the last tickle. Never hold the tube by its neck alone. It's the weakest part. Neck-holding may be done for balancing, but not for support of the tube weight. To further increase the safety factor, it's recommended that the installer wear a pair of safety goggles and apron, or other substantial piece of clothing. A fractured tube can implode and fling dangerous glass splinters.

Since the step-by-step photos show the general technique for removing the picture tube, let's consider variations from one set to the next. The first major consideration is observing how the tube is mounted, for this

determines whether the chassis has to be removed from the cabinet. There are two principal systems: in the first, the tube is mounted directly to the front panel of the cabinet, true for many large, or 21-inch, sets; and, the second, where the tube is fastened directly to the chassis. (The model in the photos is of the latter type.) The system can usually be discovered by close observation of the tube. Frequently, a large tube will be seen fastened to a bracket around its forward rim. After items on the tube neck are removed (such as the deflection yoke) unbolting the forward tube support frequently permits the tube to be withdrawn while the chassis remains in place. That is, if the chassis presents no obstructions. Small tube blocking the way may be temporarily removed, but if a transformer presents an obstacle, the chassis will at least have to be pulled out part way. In the chassis-mounted tube, both chassis and

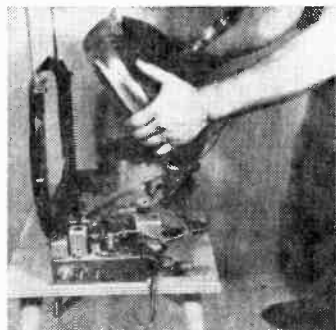

The picture tube must be withdrawn very carefully to avoid disturbing the other components on receiver's chassis.

Carry picture tube by supporting all its weight with your hand under screen; grasp neck only for balance.

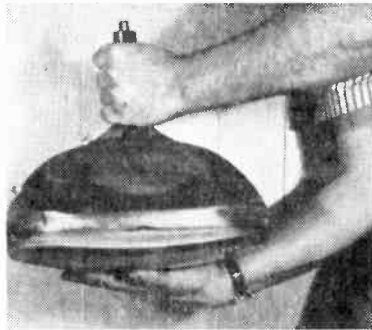

REPLACE BOOB TUBE



Avoid scratching face of old tube by placing on soft surface. Scratches increase danger of implosion and could affect trade-in value.

tube emerge from the cabinet as one piece. Generally, this type requires the removal of screws which fasten the top rim of the tube to the front cabinet panel.

Some Differences. The sequence of removing components from around the tube neck is subject to some variation. If the chassis does not have to be removed, neck components must be dismantled before the tube is taken from the cabinet. In the tube-on-chassis type, it is simpler to slide off the neck parts after the chassis is out of the cabinet. The neck components vary considerably in different sets, but this should present little problem as long as they are replaced according to the original layout. The first part to be removed is the tube socket. In many older sets it will not easily pull off. Gently insert a screwdriver at several points around the socket rim and pry it away gradually. In some sets, the next item is the ion trap. It is a small, square magnet clipped around the tube neck and held by a spring. (The set in the photos uses no ion trap.) Since the trap presents the most critical adjustment after installing a new tube, it's advisable to carefully note its position on the neck of the tube. This, at least, will provide an approximate starting point later on. (Some ion traps have a small

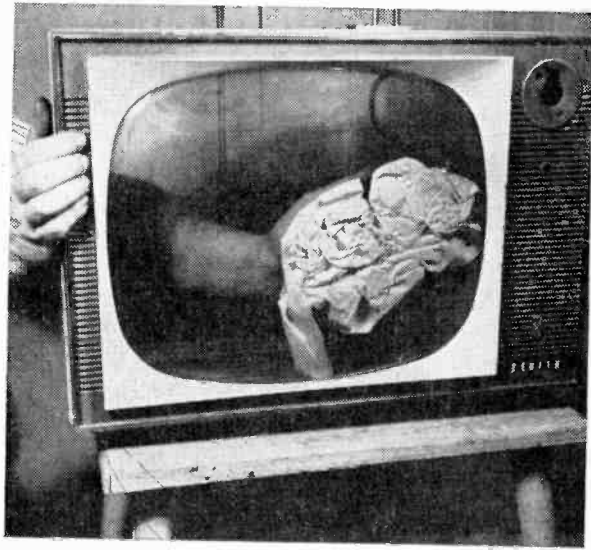

While picture tube is out of cabinet, take advantage and give safety glass a thorough cleaning with water and a drop of detergent.

arrow, which indicates the front of the set.)

Next on the tube neck is a focus coil or centering magnet assembly. It is unfastened and slid off. Finally, there is the deflection yoke which fits snugly against the flare, or bell-shape, portion of the tube. The usual fastening for this component is a wing nut, which is loosened. (Through age, the yoke may stick. Very gently work it loose.)

Installation. The new tube is inserted and mounted in the reverse order. Again, gentle handling is important. Just before the tube is strapped and bolted into its mounting, check the position of the anode socket. It should be on the correct side of the chassis to receive the anode cap. Also, check if the tube sits squarely in the mount; not slightly askew. One guide can be the marks indented by the old tube into the rubber or other soft material which retains the front rim of the tube.

The neck components are installed as closely as possible in their original locations. These positions, however will rarely be absolutely accurate, so don't give them a final tightening at this time. After you've checked everything for completeness, don't turn on the set. The following step applies if the tube uses an ion trap. Turn the brightness control about half-way up. Place a mirror in front of the set (if necessary) so the screen can be viewed while you're at the rear of the

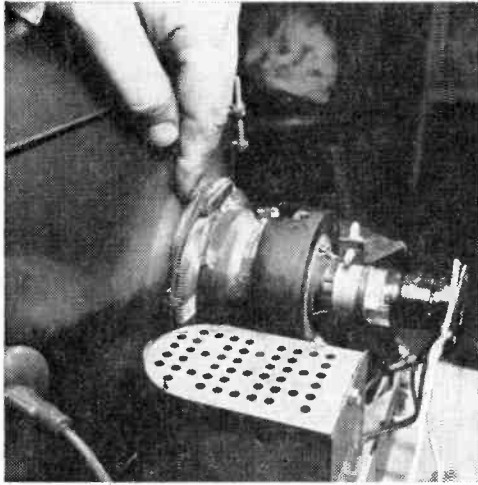

When replacing yoke on a new tube, make sure it seats against flare of tube, or picture won't fill screen.

Before replacing the back cover, check the picture for alignment on the screen. If it isn't horizontal as here, the yoke must be rotated on the tube neck.



set with one hand on the ion trap. Now have someone turn on the power. Quickly rotate the trap about the neck, and move it back and forth, until brightness appears on the screen. If two positions provide light, use the brighter of the two. This position should be found within a minute to prevent heavy ions in the electron gun from bombarding the screen and causing possible damage. Now, move the trap slightly to find the point of maximum brightness. (If you're a photo fan, you can use this trick: an exposure meter placed in front of the screen makes the job easier; watch pin for highest indication.)

Back in Focus. Now get a picture on the screen. Are its fine horizontal lines slanting? If so, small rotation of the deflection yoke permits correction. Just be sure that the yoke remains snugly against the bell of the picture tube or the image may not fully fill the screen. When grasping the yoke, hold only its insulated portion. It may be difficult, while adjusting the yoke, to check the picture for its true horizontal position (unless words, for example, appear on the screen). A convenient method is to adjust the set's vertical hold control so a thick black bar appears on the middle of the screen. This serves a good horizontal reference. Corner shadows or incorrect picture position are corrected by moving the tabs on the centering assembly. Finally, touch up ion trap again; other adjustments may have thrown it off slightly. ■

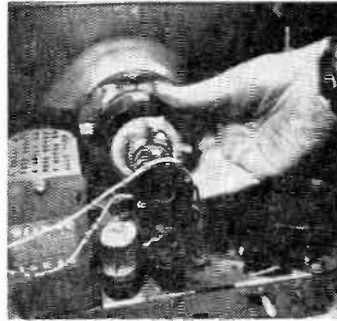

When rotating the yoke around the tube neck, grasp only the insulated cover of the yoke.

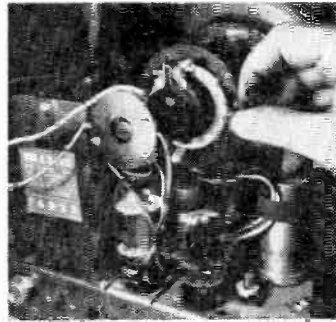

To center picture on screen adjust the two metal tabs on the centering of magnet assembly.

YOUR KEY TO TV'S QUICK & EASY

With Knight-Kit's KG-685 color-bar/pattern generator on the bench you're ready for most color-TV servicing

■ The Knight-Kit KG-685 is a solid-state color bar and pattern generator that combines in a single cabinet all the test signals and conveniences needed for proper adjustment of color television receivers. To insure compatibility with all receivers the KG-685 provides for three different signal coupling methods. The primary output is a coaxial cable (terminated in alligator clips) which provides an RF test signal on channels 3, 4

Completed KG-685, ready to deliver any one of seven different test patterns. Unit is equipped with special metal mirror that unfastens from bottom of cabinet, permitting service technician to observe TV screen while making adjustments.

or 5. Best performance is obtained by utilizing an unused channel frequency and the user determines the exact output frequency via an adjustment on the unit's rear apron.

For receivers that require a video test signal the KG-685 provides a composite video signal at a front panel jack. The composite test signal is variable from -2 to $+2$ volts peak-to-peak. For those sets which strip the sync signal off before the video detector, the KG-685 also provides a separate sync signal at a front panel jack.

Pop Patterns. Seven test patterns are provided: dot, cross hatch, vertical lines, horizontal lines, color bar, purity and gray scale. The purity pattern provides full screen red, green and blue when used with the gun interrupter switches (gun killers). The gray scale is used to check for optimum black-and-white adjustment of color receivers.

Proper receiver adjustment is indicated when all six levels of brightness (gray scale) are reproduced in black-and-white with no trace of color tint.

Fourteen one-raster-line-thick horizontal lines and nine visible vertical lines are provided. The intersection of the lines provides the dot pattern. Either the dot or crosshatch pattern is used for static convergence of the three color guns while the vertical and hori-

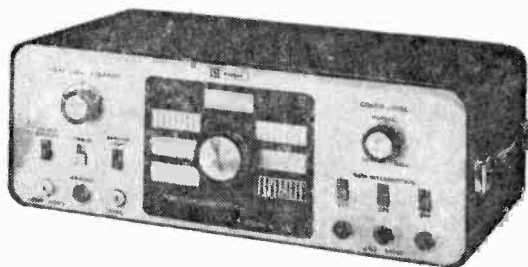

zontal bars are used for dynamic convergence. Naturally, either the vertical and horizontal bars or the crosshatch can be used for linearity adjustments on color or B&W receivers.

Though the KG-685 is a rather complex kit—22 transistors and 8 diodes—most of the circuitry including the frequency determining elements are mounted on two printed circuits, thereby reducing assembly complexity and the possibility of wiring errors.

Considering the number and nature of the output test signals and the conveniences for simplifying the service technician's adjustment procedures, the KG-685 priced at \$89.50 in kit form, ranks as a first choice in color bar generators.

For additional information on the KG-685 write Allied Radio Corp., 100 N. Western Ave., Chicago, Ill. 60680. ■

ERECTING A TV TOWER

by Homer L. Davidson

■ You don't have to be an expert to install your own TV tower. If you have a few ground tools around, such as a spade or shovel, and a strong back you are in business. A little elbow grease is all that is needed.

The TV tower has many advantages over the TV antenna pole installation on top of the house. One of the greatest assets is to get away from the wind vibration, in which the house acts as a sound board. With tight guy wires, running from the antenna mast and anchored to the house, vibration of the antenna itself, will play like a bass guitar. This noise on windy days can and will drive a person out of his mind, or make you want to push the panic button several times.

Also, the antenna on top of the house looks unsightly compared to a tower job. The antenna mast and foot mount corrodes and rusts out leaving brown rust spots on the new shingles. In level terrain the wind plays havoc with the guy wires, and if one guy wire breaks, as in many cases, down comes the antenna, mast and all. You might wind up with a damaged roof, and, of course, the antenna itself will probably be mangled and have to be replaced. And further, in parts of the country where ice and snow is a problem, it is much easier to climb a tower to fix the antenna or broken leadin.

Most TV tower installations between 20 and 40 feet do not need separate guy wires; these towers will stand alone. The cost of a TV tower will vary from \$50.00 to \$125.00 more than a roof top installation. Of course the exact amount will depend on the height of the TV tower.

Installing the Tower Base. First, pick out a good spot where the tower will not be in the way when walking or mowing the lawn. Install the tower close to the TV set or outlet.



To plant tower you'll have to dig a hole first (left). Make it 40-inches or so deep—and some 2-foot square. If the soil is loose make base larger. Soil around new homes should be compacted or self-supporting tower may settle and tilt.



Do your digging in the cool weather and you won't be likely to have heat stroke (above). Just be sure it isn't freezing when you're ready to pour the concrete.



Spirit level is needed to get tower up straight. Prop it securely until concrete hardens.

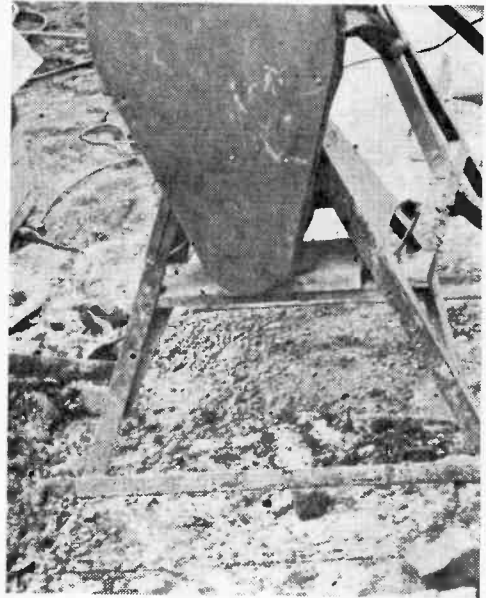

Work concrete into the hole—bubbles will only make foundation weak. Any looseness will increase the possibility of tower swaying and will reduce its ability to withstand bad storms, winds.



If you have a small cement mixer don't wait too long between batches of concrete. It must be mixed into one solid mass. Keeping mixer close to hole eliminates need for barrowing.



You can just fill hole to within an inch or two of the soil's surface and cover with sod. Some prefer to place form around base for squared-off masonry top.

Keep away from flower beds and small shrubs. Most towers are mounted at the rear of the house, out of the way. You should never have over 100 feet of lead-in wire over-all. Do not mount it where the tower will block the view of a window. Locate a spot near the house where the tower will clear the eaves with a space of from 8 to 12 inches.

After you have found the best location dig a hole about 40 inches deep and 2 feet across. The diameter of the hole should vary according to the ground soil. If the soil is loose, like that around a new home, the sides will tumble in at the top. In hard firm soil a clean hole can be dug straight down. If you or your neighbor has a post hole auger handy, start first with this at the center of the hole.

Auger down a couple of feet and spade off the remainder of the dirt.

When you have dug to the required depth, you may want to scale back at the bottom. In other words, flare out the bottom of the hole. When the cement is poured into this hole we have added strength to the tower base. Keep the loose dirt picked up. Either place it in a wheel barrow and haul it away or lay down heavy paper so the dirt isn't tracked all over. If you have a good stand of green grass growing, this is a must. You will need some dirt to go on top of the cement base if you want grass growing around the tower. Do not haul it all away. You may want to fill around the house, flower beds, or low spots in the lawn with the extra

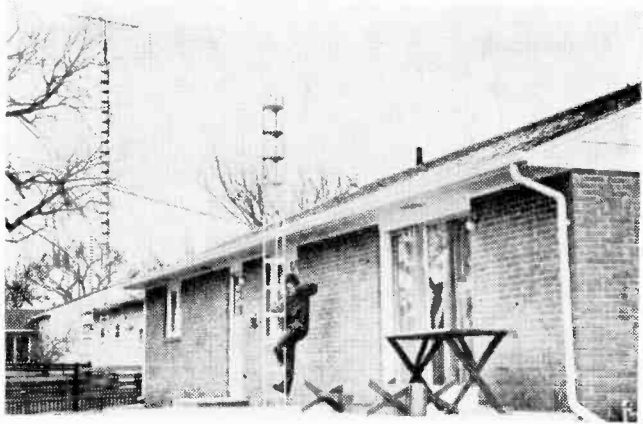

Concrete must be firmly set before you start adding the other sections to the section set in the concrete base.



Make sure concrete has cured completely before attempting to climb or work on mast. Poorly set concrete will loosen and crumble.



loose dirt you will have left over.

If the concrete base is to support a fifty foot tower or higher, a larger and deeper base should be used. A 50 foot tower with a house bracket can be supported with a 3½ foot by 18 inch square hole. If the tower is higher, use a 2 foot square cement base.

Before the tower is placed in the hole pour in about three inches of rock gravel. Set the bottom section of the tower into the hole. Be sure that the small tapered end of the tower is up. If the tower section bolts are found in one leg, be sure to remove them before placing into the ground. Many of the new galvanized towers have a protection plug in one leg in which the mounting bolts are packaged.

Now place the tower in the hole and throw a couple of inches of gravel around the three legs. This allows moisture to drain into the gravel. In parts of the country where water will seep into the tower legs and freeze in the winter months the tower legs will split open. Splitting of the tower base will weaken the tower and may come down under strong winds. This may take years for the water to build up in the legs of the tower, but it has happened.

By placing the bottom of the tower down into the concrete a strong base is made. You can buy three-foot tower legs to go down into the concrete but a weakened bolt joint is just above the cement base. You can gain back the forty inches of sunken tower by placing



Orient the antennas—the last step. Double-check all fastenings before you start down to ground.

Dress lead-in and attach stand-offs as you climb down mast.

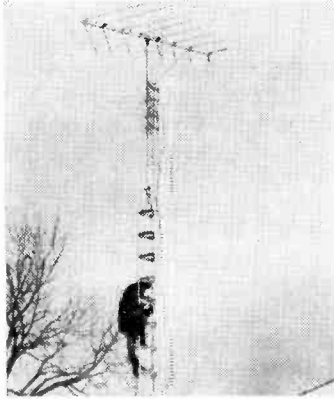

Completely assemble the antennas on the ground and hoist the completed units to top of tower. If you're using a rotor mount that first.

a piece of antenna mast above the top tower section, if needed.

If you are going to mix your own cement with a small cement mixer use a 5, 3, 1 mixture. Use five parts rock to three parts sand to one part cement. These may be shoveled in or first mixed in a wooden box. It is quite expensive to have a small load of cement hauled in by a commercial cement company. You may want to check the prices first as these vary in different localities. In case there isn't a cement mixer in the neighborhood, rent one for a few dollars from a rent-all establishment.

Large rock or used brick may be used as filler. But, be sure and level up the tower

after each cement mixer load. Check the level on each leg of the tower to see if it is perfectly straight. This bottom base section must be perfectly perpendicular so the tower will not lean in any direction. Always depend upon the level or even a plumb line hung through the center of the section from the top.

It will take from four to six loads of average cement mixture to fill this type of hole. If you plan on growing grass above the tower base leave six inches for dirt fill. You may want to have a square cement base above the ground. Simply nail four pieces of 1 x 4 together and level above the ground, around the tower. Pour the cement level with the top of the boards and trowel down the top surface.

After each cement load, push the cement around in the hole. If the cement is mixed quite wet, the mixture will pour and level much easier. The hole may be a little irregular, but fill it up with the concrete mixture.

Leave the concrete set up for at least two days before attempting to work on the tower. It is best to cover the top of the cement base with heavy cardboard, or paper, while ripening and setting up. This will keep rain, snow, or foreign objects from falling in on top of the fresh cement. Have you given that level a final check? Do it now; check the level of the bottom section several times during the setting up period.

On Upward. When the tower cement base has set up, you can now place the next ten foot section in place. If a reamer, or round file, is handy, clean out the sleeve of the enlarged end of the metal tower. A ten or twelve inch tapered punch will help to align up the tower ends.

One person can lift the second ten foot section of tower into place if need be. But, two men can do it a lot faster and safer. You can lift this section in place from the ground. You may have to tug on the last leg to get it to align up and then pull down on the tower. Line up the holes with the tapered punch. Insert the mounting bolts. Leave the nut and threaded end of the bolt toward the inside of the tower.

If the bolts are hammered through the tower sections, the threads will become stripped. Use the punch to align the sections so the bolt will pass easily through the legs. Do not drill the holes larger. Be sure to tighten all leg bolts until they partially flatten the sleeves, causing the sleeves to actually grip the legs inside. Upon tightening the



TV TOWER

bolts, there should be no vertical movement between tower section at the joints when working on the tower.

You do not need any special hoists, or gadgets to lift the tower sections in place. Simply put your arm through the second round section, from the top, and climb up the tower with the added section on your shoulder. The third section may be lifted in place with one person standing on the house and the other person on the tower. If not, one should climb to the top, stick one leg down through tower and out on the second brace. You cannot fall out of this position. A climbing belt is also useful, but not necessary when working on the TV tower.

While one person is in this position another can bring the tower section up the tower. Don't worry about the tower holding the two of you; it will hold up several people. The person in the tower can raise it and balance the tower while the other fits the sections together. Each section should be bolted before another section is raised in place.

The top tower section has a large piece of pipe for the antenna mast to stick down through. If the antenna is to be in a fixed position a set screw is located in the mast housing. A rotator may be mounted on top of this pipe and the antenna above it. You can install the rotator inside of the top section. There are rotator mounts for this type of installation.

If the rotator is to be mounted at the tip of the tower, fasten the leadin wire to the correct terminals before mounting. Now mount the rotator in place and tape the rotator cable to one leg of the TV tower. The

antenna should be folded out and leadin cable added to the antenna terminals. Wrap these terminals with friction tape and place a mast standoff within six inches of this antenna connection.

Carry the antenna up the tower and swing in place. Tighten the antenna brackets and seek the right direction for the fixed antenna. If it is to be mounted on a rotator check and see if the rotator is a north to north direction rotator. Point the antenna north and bolt in place. Be sure and face the correct end of the antenna in the northerly direction. On yagi or flat type antennas, the shorter end always points toward the front of the antenna, or towards the TV station.

Leave a loop of wire so the rotator will turn freely and not bind as the antenna is being turned. Place an antenna mast standoff above and below this loop. Space the antenna mast standoffs every four feet down one leg of the TV tower. Do not clamp this mast strap over the rotator cable as it can, when tightened, ground out the rotator cable to the TV tower.

Be sure to keep the antenna standoffs in line down the tower. For local UHF reception, place the UHF antenna below the rotator or the large VHF antenna. If there are several UHF stations in the area, mount the antenna above the VHF antenna on the TV rotator.

Cleaning Up. Clean up the area around the base of the TV tower. If the cement mixture has splattered on the legs of the tower, let dry, and then wipe off. Protect the brick or house siding from cement splattering with cardboard or heavy construction paper.

Remove any temporary guy wires, if used. Check the direction of the TV antenna. You should zero the antenna in with someone watching the TV reception on a fixed position. Since most antennas tend to be directional, you'll want to try all the channels in your area, then pick the antenna orientation that works best. In many cases, this will of course be a compromise.

You may want to use a house bracket and extend the tower another ten or twenty feet. These brackets come in adjustable lengths and lag to the side of the house. Most towers should not be mounted more than 30 feet above the house bracket. You may go up to greater heights by guying the TV tower. Fasten a set of three guys on every twenty feet of tower. ■

TOWER MANUFACTURERS

E-Z Way Towers, Inc.
5901 E. Broadway, Tampa, Fla.
Rohn Mfg. Co.
P.O. Box 2000, Peoria, Ill.
Tri-Ex Tower Corp.
7182 Rasmussen Ave., Visalia, Calif.
Vesto Co., Inc.
20th & Clay, N. Kansas City, Mo.
Tristao Tower Co.
415 East 5th Street, Hanford, Calif.
Aermotor Towers
Broken Arrow, Oklahoma 74012

By Francois Markette

Ry for W-Ts

Inoperative walkie-talkies aren't the easiest thing to repair, but first aid is often all that's needed

■ At first glance a disabled CB walkie-talkie (W-T) might appear a formidable service job. With the parts jammed together cheek-to-jowl it seems almost impossible to get at the test points with test prods, let alone with a soldering iron. In actual practice, however, W-T repairs rarely get deep into the circuitry; more often than not it is the easily accessible components that are the culprits.

As ridiculous as it might sound, many W-T problems are often nothing more than "plugging in the line cord." Yes, we all know of the instance where the little woman called a TV technician when the problem was that someone had pulled the line-cord from the

AC receptacle. The very same things happen with W-Ts; non-technical users often assume a W-T is defective when all it needs is a new set of batteries.

Begin With The Batteries. First step in any W-T service job is to determine if the batteries are okay. Turn the power switch on and then connect your voltmeter across the battery. If the battery indicates *good*, activate the transmit switch and again note the meter reading. If the battery voltage falls below the minimum usable value when the transmitter is on, the batteries are defective.

The reason the batteries must be checked under the heaviest load (which is during transmit) is because even a "dead" battery

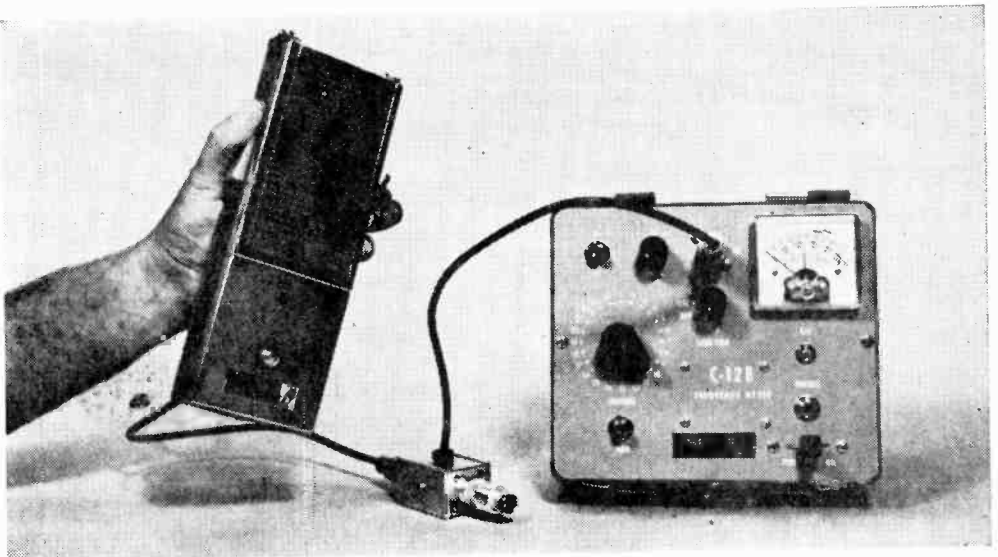

Because of their high selectivity, high-performance transceivers should always be checked with a frequency meter. Test instrument in photo above is an International Crystal C-12B.

will indicate normal when there is no load; it is the relatively high internal resistance of a defective battery that causes the terminal voltage to drop under load.

As a general rule a W-T should work down to half the rated battery voltage. For example, if the W-T uses a 9-volt battery, it should operate down to 4.5 volts (though some W-Ts will not work if the battery voltage falls below $\frac{1}{3}$ rated voltage).

Pinpoint The Section. Next step is to check which section—the receiver, transmitter, or amplifier/modulator—is defective.

the W-T's speaker leads (see illustration).

If you want to check the entire modulator/speaker system, feed an AF tone into the modulator (across the volume-control terminals) from a standard AF signal generator or from the AF output of a CB service set. In a pinch, you can even connect the output of an AM radio across the W-T's volume control.

Transistors And Switches. If no amount of checks can get a signal in or out of the W-T, make a quick-and-dirty transistor check *before* you start unsoldering transistors. Luckily, when transistors fail they usually short-circuit, and the resultant heavy current flow causes the transistors to run relatively hot. Simply place your fingers on each transistor; the hot one can be consid-

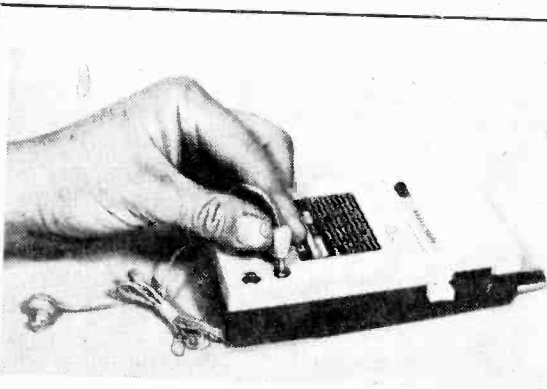

Common source of "no sound" is flimsy headphone jack (above) which might fail to make normal/through-speaker connection; remedy is to clean or replace jack in effort to increase spring tension. At right, non-technical users often assume W-T is defective when selector has been accidentally moved to unused channel.

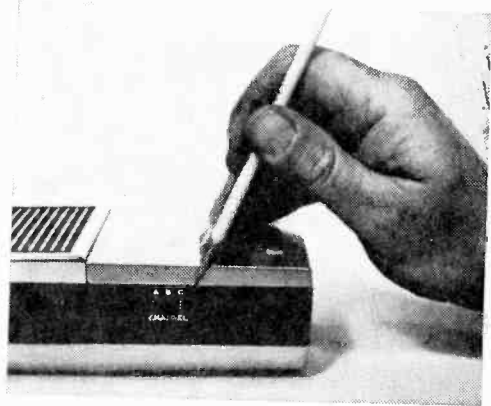

The best piece of service gear for this job is a standard 5-watt CB transceiver. Transmit a signal from the transceiver and try to receive it on the W-T. If the W-T cannot receive the signal the amplifier/modulator or receive section is at fault. Next, try using the W-T to transmit. If it works, this means the receive section is defective.

If the W-T can't receive and can transmit only a carrier (no modulation), look for the difficulty in the circuit common to both the transmitter and receiver—the modulator, including the speaker. Easiest way to check the speaker is to simply unsolder one speaker lead and then clip a second speaker across

ered defective. If none are hot, look for other troubles before you tear the printed-circuit board apart.

A common source of intermittent operation and complete failure is the receiver/transmit (transfer) switch. They are usually small, and a single speck of dirt is all it takes to lift a contact. Insert an extension tube in the nozzle of a pressure can of contact cleaner and literally blast the cleaner into the switch, constantly operating the switch as you spray. Then pray it does the job, for replacement of a multi-contact transfer switch is a time-consuming, difficult procedure.

The Big Jobs. High performance W-Ts often require nothing more than frequency checks to restore lost performance. Whether it's a 100-mW or 5-watt W-T, a high-performance model is as selective as a standard 5-watt, high-performance transceiver. Should the transmit crystal drift just slightly off-frequency, it would move the out signal outside the passband of the companion high-performance W-T. Similarly, if the receive crystal drifted the W-T would receive only the sidebands, or no signal, from a companion transmitting W-T.

Best way to check high performance W-Ts, then, is with a frequency meter, providing you are certain the W-Ts *can* transmit and receive.

First step in checking the frequency of a

frequency, or vice-versa. Often, just normal component aging can effectively shift the frequency of either the transmit or receive crystal, or possibly both.

While a frequency-meter can be used to feed a signal into a receiver, there is really no way to easily determine if the receiver is tuned exactly to the test signal. It's therefore advisable to make certain the transmitter is on-frequency and then use it as the signal source to check the companion W-T.

High performance W-Ts should also be checked for RF power output if an external antenna jack is provided. Using a fresh set of batteries, or a fully recharged NiCad battery, connect a power meter to the external antenna jack and key the transmitter. The W-Ts power output should be at least 50%

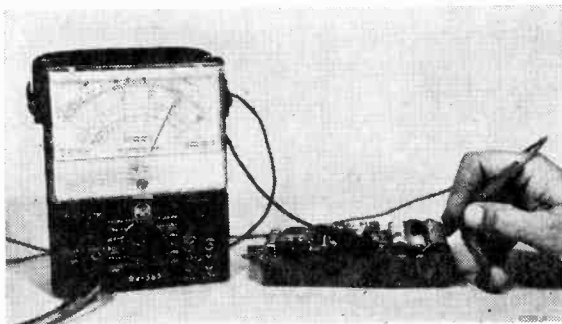
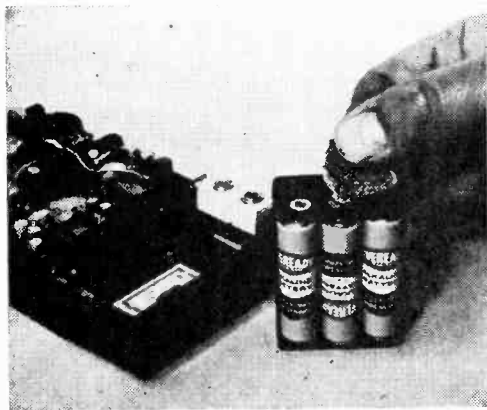

Corrosion on battery-holder terminals leads to intermittent operation, particularly if W-T is used around salt water; best cure is to sand off corrosion with fine sandpaper. Above, always check batteries under load, since output voltage can vary greatly. Batteries here registered 9V with no load, 8V on receive, 4V on transmit.

high-performance W-T is to make certain the transmitter is on-frequency. (This is done best by checking the deviation from center-channel.) If the transmitter is on-frequency but one or both cannot receive each other, the difficulty lies in the receiver section, which is simply not tuned to the transmit frequency.

Remember that W-Ts rated above 100 mW must conform to Class D standards; 100 mW and under units need not. As a result, the little fellows are often considerably off the center-channel frequency. If the frequency-meter shows such to be the case, the receiver must be retuned to the transmit

of the rated power input, i.e., 2.5 watts output for 5 watts input.

Just as a weak crystal can degrade receiver sensitivity, a weak crystal can result in reduced RF power output, even though the crystal is within 0.005% tolerance. Therefore, if power-output measurements are a bit on the low side, try replacing the transmit crystal before tearing into the wiring. This you can do by using the crystal(s) from the companion W-T.

Oddball Defects. NiCad-powered W-Ts can't readily have their batteries tested with a voltmeter because "dead" battery voltage is generally only a few tenths of a volt below

"normal." If a NiCad-powered W-T gives poor receive and transmit performance, check that the battery charger is delivering the rated output voltage.

If it checks out okay, connect a milliammeter in series between the charger and the NiCad battery to see if the charger is delivering the rated charging current. If both current and voltage check out, it's time to suspect the battery. Contrary to popular belief NiCads don't last forever; instead, they have a definite rated life, and at some time will require replacement. (A NiCad's life is generally in terms of "recharge cycles" rather than time. A NiCad should be good for at least 500 to 1000 "cycles.")

W-Ts with built-in AM radios often cause confusion because the radio works while CB performance is low or nil. Keep in mind that the AM radio's IF amplifier and AF amplifier are common to the CB circuits, so if the AM radio works you can be certain the trouble is not in the IF or AF amplifiers or modulator (AF power amplifier). Similarly, if CB reception is distorted but the AM radio is clean, the speaker isn't defective.

Just as with a receive/transmit switch, the AM/CB changeover switch is easily fouled by dirt. The remedy is the same: simply "blast" the changeover switch with contact

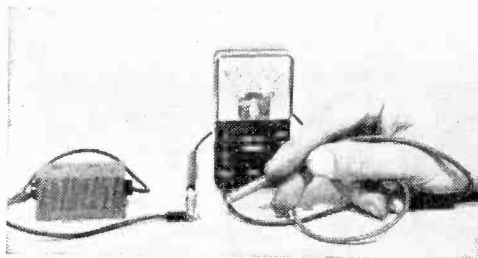

Even battery chargers have been to blame for W-T failures. Though indicator lamp on the charger above lit, charger was defective.

cleaner. This will often restore "lost" CB performance on an AM/CB W-T.

Though the above comprise only the easiest W-T checks to make, most W-T problems appear in the "accessory" components, not in the basic electronics. Of course, if you finally trace the trouble to a defective component or circuit on the printed circuit board you will have to get in there with your soldering iron and troubleshooting skill.

Always keep in mind that a W-T is basically no different than any other solid-state transceiver—it's just smaller. For this reason, standard troubleshooting techniques should be used on the W-T circuits. In general, however, it is dirt, water, and shocks from rough handling that cause most W-T problems—not electrical breakdowns. And most often just a cleaning, speaker or crystal replacement is all that's needed to put a W-T back in working order. ■



Receive/transmit switch is common cause of intermittent operation; cure is to attach injector tube to nozzle of pressurized contact cleaner and blast out dirt while simultaneously rotating switch shaft.

Easiest way to check W-T's speaker is to disconnect one speaker lead, then jumper in replacement speaker. If replacement results in improved sound, original is defective.

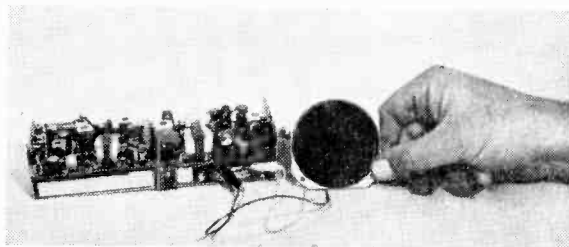

HOW TO CHANGE

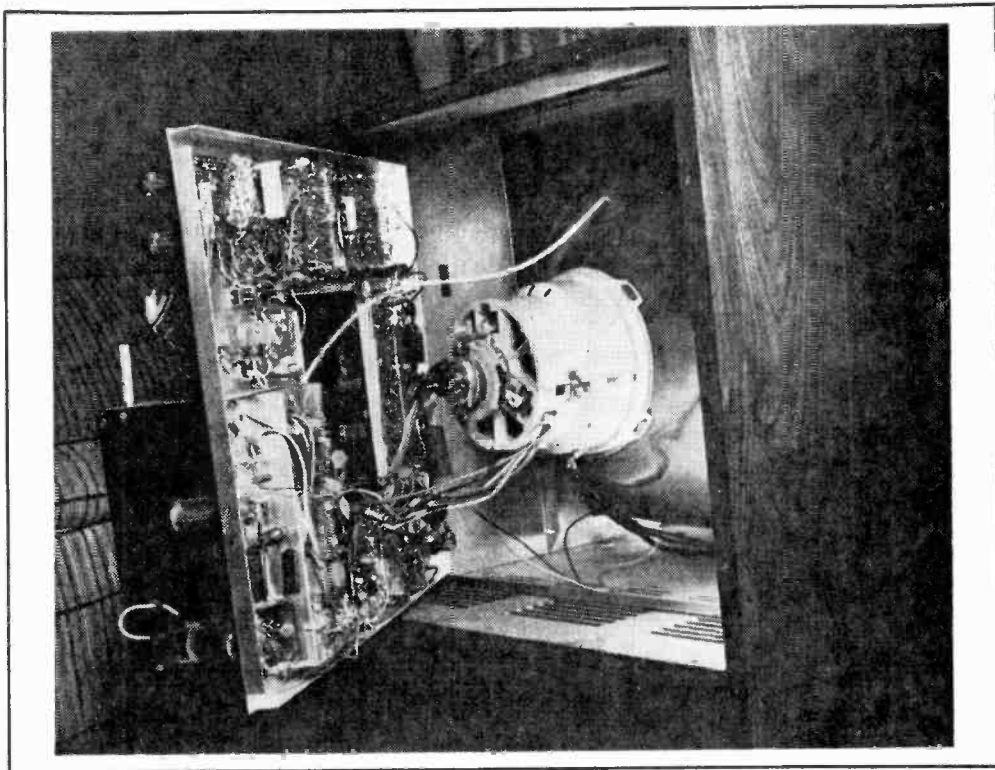

A COLOR TV TUBE

By HOMER L. DAVIDSON

■ When your color picture tube becomes dim and one or two colors are real weak, you can replace that color tube yourself. Follow the photos and text in this article and you can save yourself some dough. This article shows how to replace the round and rectangular color picture tubes. The sizes are 21-inch round, 25-, 23-, and the 19-inch rectangular color CRT's.

The initial preparation consists of taking the TV chassis from the cabinet. First, remove all knobs and the rear cabinet cover from the TV receiver (Fig. 1). Discharge the high-voltage charge of the tube with a long, insulated-handle screwdriver—from anode connection to the TV chassis. Be real careful, and do a good job of grounding out the high-voltage cable. In older TV re-

ceivers, the high-voltage cable must be unfastened from the metal box before you open the lid of the box. This lead will pull out of a pin socket. In newer TV sets, the high-voltage lead unplugs from the glass picture tube. Unbolt the TV chassis and unplug all wires going to the TV chassis.

This includes the picture tube cap or socket, yoke leads, and speaker leads. All the colored wires going to the deflection yoke are marked on the yoke where they are plugged in. There is little danger of getting them wrong when replacing them. Unhook the blue grounding lead from the blue lateral magnet. Unplug the convergence yoke cable from the TV chassis and also loosen the antenna terminal assembly.

Before pulling out the chassis, be sure

CHANGE COLOR TUBE

all cables and wires are disconnected. On the older models, pull out the chassis three or four inches and loosen the 1/4-inch metal screw, holding down the small-controls assembly. Slide the assembly back and pull up. Now the chassis is free (Fig. 2).

The Tube Comes Out. The cabinet should be turned over on its face before removing the color tube. Be sure to lay a blanket or thick padding upon the floor to keep the cabinet in ship shape. Have a friend (Fig. 3), or the wife, help place the TV cabinet front down upon the padding.

In the older color sets the dynamic convergence magnet assembly (Fig. 4) slides

separately off the neck of the tube. In the rectangular 25-inch sets the yoke assembly also contains the convergence coils and fits tightly against the color tube.

Four nuts hold the picture tube in place—two at the top and two at the bottom. A metal flange surrounds most tubes, near the face of the tube. In the newer color sets, the automatic degaussing coils (ADG) are fastened to this framework. In the 25-inch sets the metal flange must be removed before you can get to the nuts holding the color tube in place.

Now remove the components from the neck of the color picture tube. In case you are not familiar with the location of these components, measure their position (Fig. 5) on the neck of the color picture tube. This procedure is quite helpful when replacing

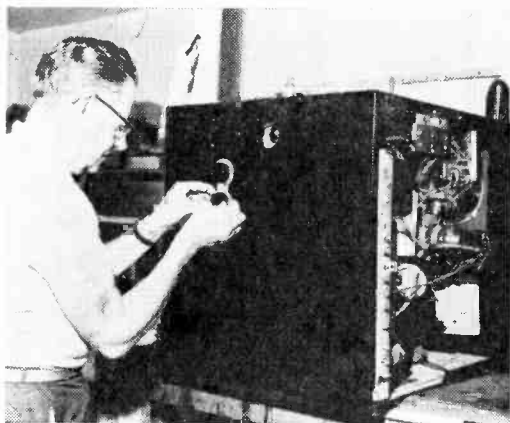

Fig. 1. (top, left) Removing the control knobs. Fig. 3. (below) Place cabinet face down on folded blanket to protect finish. For console combination remove all records and tie down record changer arm to prevent damage to unit. Fig. 4. (right) Point of pencil indicates the setting of convergence yoke and red band.

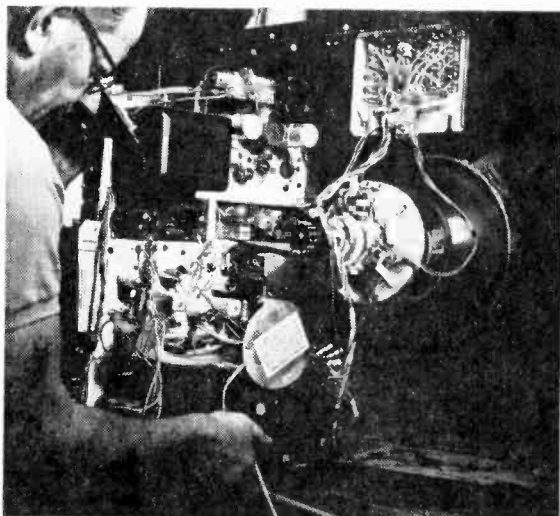
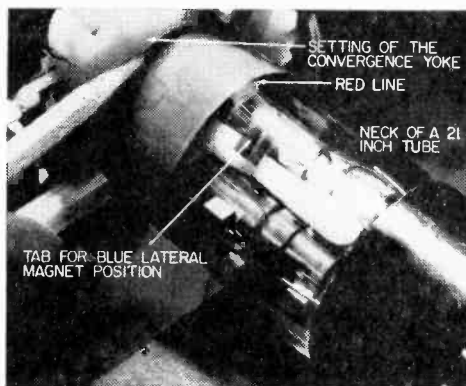

Fig. 2. (above) Don't be afraid to make notes about various connections as you disconnect chassis from CRT and yoke. It can save you a little hunting later.



these components to the neck of the new color tube. *As a safety precaution, wear safety glasses when working close to the picture tube. Do not put pressure on neck of CRT or let tube rest on neck.*

Clear the Neck. Place the kinescope face down on a drop cloth or newspaper to protect the face from scratches. Now remove the components from the neck of the tube. When you remove the blue lateral magnet, you will notice that it sets over a tab or clip inside the tube neck (Fig. 6).

In the older sets, the purity ring sets over the red ring marked inside the tube. Note that the blue wires from the convergence assembly (Fig. 7) go to the top of the picture tube over the blue gun, the red wires at the left side, and the green wires on the right going to the green dynamic convergence coils.

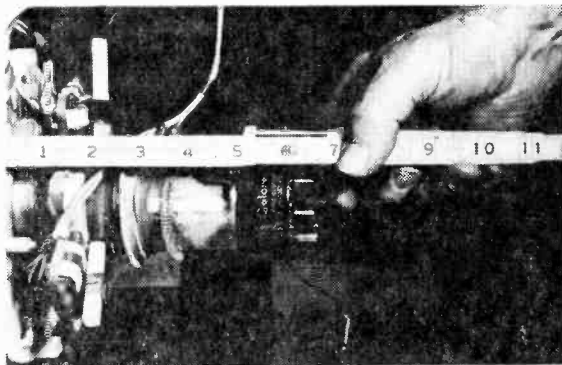
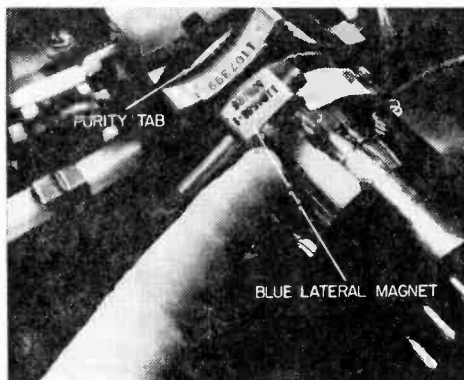

Fig. 5. (top) While you are making notes be sure to mark down the measurements so you can replace the yoke assembly physically before worrying about convergence, purity. Fig. 6. (below) Here author is pointing to blue lateral magnet and the tab inside the neck of the CRT. Tab is not obscured by blue lateral magnet in Fig. 4. By first replacing the components according to the measurements most adjustments are minor.



The large deflection yoke is loosened with a 1/4-inch nutdriver (Fig. 8) and can be lifted off the neck of the tube. It is very heavy; do not drop it! Be especially careful not to rap the CRT with a tool or heavy object. *The CRT must be handled with care since it can implode and cause serious damage to you and the set.*

The masking must be removed from the front edge of the CRT, as in Fig. 9. On the rectangular tubes, a strap with corner flanges must be removed by loosening a side-bracket bolt. Remove the bracket (i.e., masking) assembly from the old CRT and place it upon the new tube.

Be sure the CRT is laying in the same position as mounted in the TV cabinet. Now place the strap in place on the new CRT and tighten up the bracket assembly. Be sure the high-voltage (anode) button is at

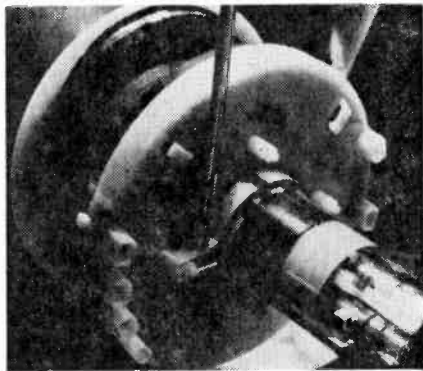
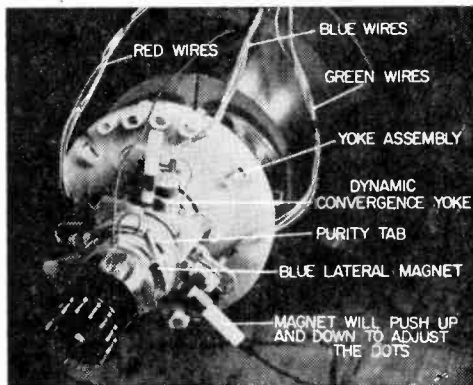

Fig. 8. (above) After yoke assembly has been loosened with nutdriver it can be removed. Assembly is quite heavy—don't drop it.

Fig. 7. (below) All components of the yoke assembly are indicated. Once you can tell the difference between a dynamic convergence yoke and a purity magnet you have an easier job of following these instructions.



CHANGE COLOR TUBE

the top of the set on a 25-inch picture tube (Fig. 10). The 23-inch and 21-inch round-CRT anode connections (Fig. 11) are on the side of the tube.

Reassembly. Place all components back on the neck of the CRT. Use the previously taken measurement for their approximate position. In the older sets the yoke must be mounted so it will slide back and forward for purity checks. The 25-inch yoke assembly fits snugly against the bell of the tube. This yoke slides back and forward inside of the large yoke assembly. Two small screws are loosened on each side of the plastic yoke assembly.

Tubes that are not bonded have a safety

glass—be sure the glass is clean. Wash it with soap and then rinse with clear water. Make sure there is no lint or dirt on the face of the new CRT (Fig. 12). Seat the tube in its place in the cabinet and bolt it to the front brackets. Replace the metal shield and degaussing-coil assembly, if the set has one.

Now set the cabinet upright and fasten the convergence board in place (Fig. 13). Install the TV chassis and connect all cables. Make certain that all parts are replaced and tightened. Banging against metal parts will sometimes induce magnetism into these parts and a second job of degaussing may be required. Be sure that all cables are connected and in place. Turn on the color receiver and leave it on for 15 to 20 minutes before purity or convergence checks are made.

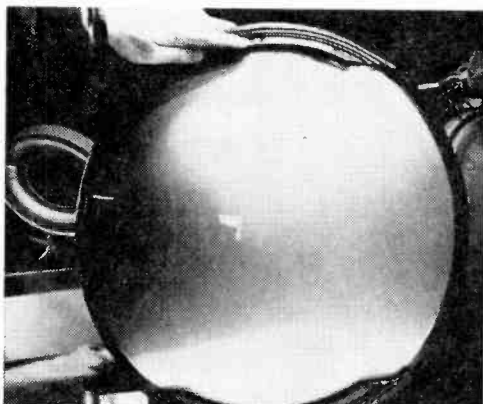
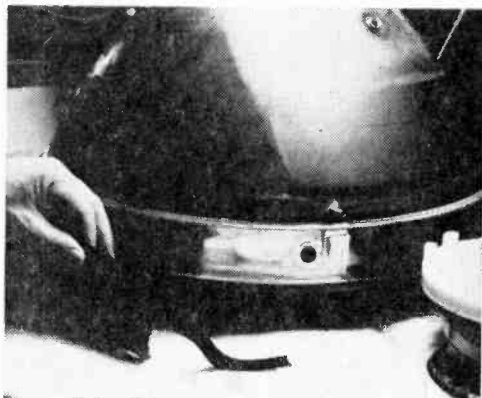

Fig. 9. (top, left) Make careful note of how the front protective mask is removed from CRT to make replacement much easier. Plastic mask on 21-inch CRT must be placed evenly (top, right) before taping in place.

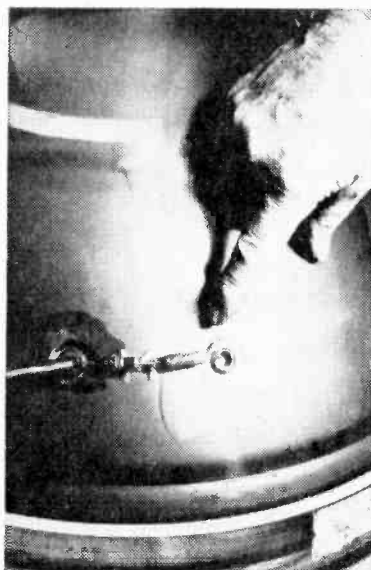
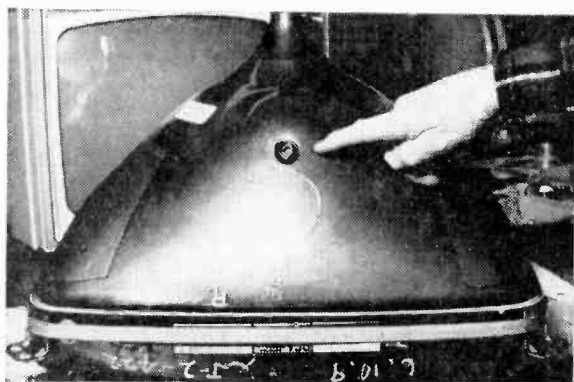

Fig. 10. High-voltage connector is at top of 25-inch CRT's—on side of 19- and 23-inch CRT's. Make sure!
Fig. 11. Resistor, with spring, bridges anode buttons.

Basic Adjustments. Color-TV convergence can take time and may require skill. You may want to degauss and converge the color TV yourself, if correct equipment is available. If not, get help from a good reliable color-TV serviceman and pay him to finish the job.

If you want to do it yourself; here goes: Position a degaussing coil near the picture tube (Fig. 14) to completely neutralize any induced magnetism. This step will help insure proper purity and convergence when the picture tube is converged. Hook up the Dot-Bar color generator and let it warm up as the color-TV set warms up. When replacing the CRT, even sets with built-in degaussing coils should be degaussed just as if one was not built into the TV cabinet.

Take a quick look at the TV screen and if there are any color shaded areas the set

should be put through a purity check up.

To start the purity adjustment (Fig. 15), turn off the set and unplug the IF cable going to the tuner. Plug the AC-interlock cord back in, let the receiver warm up, and short out the green and blue grids through a 100K resistor. (There are commercial kinescope grid-shortening switch boxes on the market for just this purpose.) At the moment the screen should be red. Adjust the center purity ring for a center red coloring. Then push the yoke back and forth and adjust the purity ring until the entire screen has an even red tint. The red-, blue-, and green-grid connections are generally on the top of the chassis. These three colored wires go to the picture-tube socket.

If the purity adjustments are done correctly, the green and blue shading will fall in line. It is always best to check each one

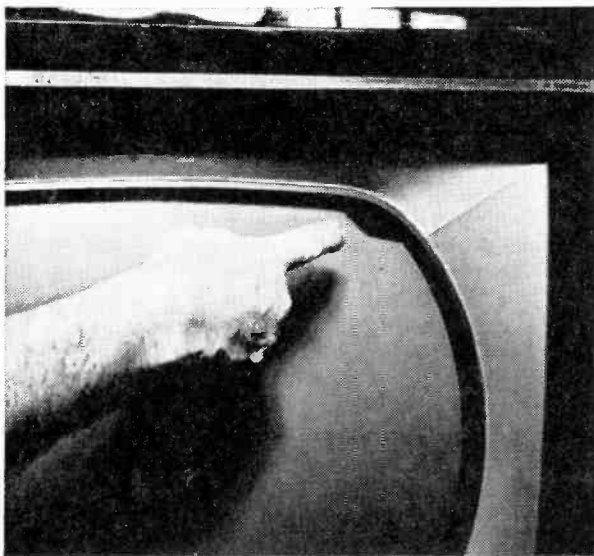
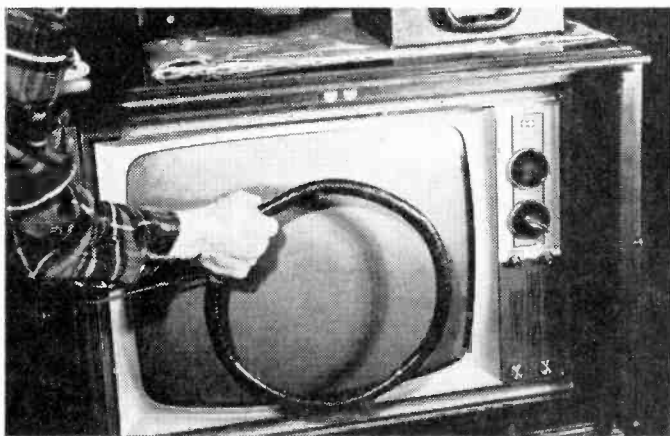

Fig. 12. (top, left) When replacing CRT's that are not bonded, safety glass must be cleaned of fingerprints and lint. Double check mask to make sure it is aligned properly in set.



Fig. 13. (top, right) When convergence board has been reinstalled and all nuts and machine screws have been tightened the chassis can be returned to the cabinet and secured too.

Fig. 14. (right) Degauss the CRT even if there is a built-in degaussing coil.



CHANGE COLOR TUBE

separately by shorting the other two grids to ground through a 100K resistor. If a little shading persists, try degaussing the CRT again and start over with the red adjustment procedure again.

At this time, check the level of the picture and see if the picture is in focus. Sometimes it is difficult to do a good job of convergence with the set out of focus. When you reset the focus control, convergence dots are way off.

Getting a Picture. Convergence is relatively easy on the new color receivers. The older models require patience and plenty of time. Connect the Dot-Bar generator to the antenna terminals. Remove the convergence board from the back of the set and place it on the slots at the top and back of the set. Tighten the two metal screws so the board is solidly in place. Watch the wires that connect the board to the yoke assembly so that they do not get tangled.

If the receiver was in convergence when the color CRT went bad, the dynamic convergence controls will generally need only a touch up. Set the generator to get dots on the CRT screen and check the dots down through the center of the screen. Short out the blue gun with the 100K resistor. Bring the red and green dots together on a center dot. Slide the red and green magnets in on top of one another. Readjust the setting, if needed.

If they won't quite come together, remove

and rotate the red magnet a half turn and reinsert it, and adjust again. Now, once the red and green dots are centered, short the green grid and line up the red and blue dots. (The blue-beam magnet moves the blue dot up and down. The blue lateral-beam moves the blue dot horizontally. Place them on top of one another). Go back and check the red and green guns once again. Check that all three dots are together. You should now have a white dot. The amplitude and tilt controls should not be adjusted unless the dots fail to converge.

Now, step back and take a look at the screen from a distance. Tune in a black-and-white program from a local station and check for color fringing. Generally, the convergence board does not need to be adjusted unless tampered with.

If the dots do not converge at the ends, top, and bottom, the vertical and horizontal adjustments must be made. Use the manufacturer's convergence and adjustment information and follow their alignment procedure. It is best to go over color convergence several times and then get away from the dots. Go back in a few minutes and recheck.

Follow the factory adjustment for black-and-white setup. The newer TV color receivers have a *service-normal* switch mounted at the rear of the chassis. When this control is thrown to the *service* position the raster collapses into a thin white line. You adjust the three screen controls until the vertical line is perfectly white. Now flip the switch to *normal* and the picture is black and white. ■

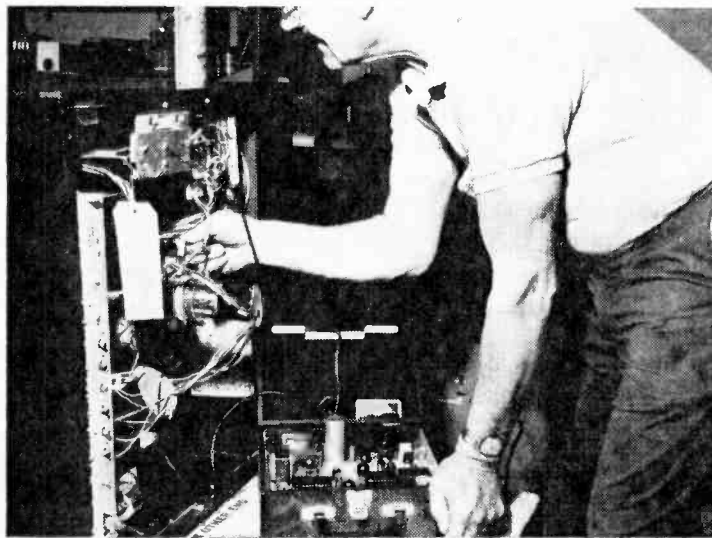
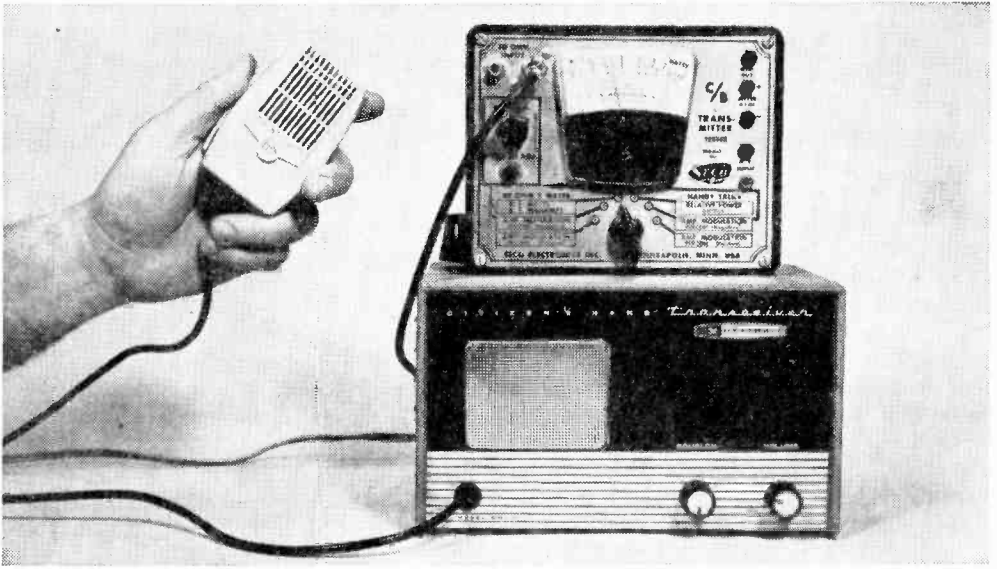

Fig. 15. The last step is the most crucial of all the steps in the replacement of a color CRT. Color purity has a lot to do with the overall enjoyment you get when watching your favorite programs. No one can thrill to faces that are tinged with green, or grass that has a purplish tinge. If you don't have the necessary equipment you can have your local TV service technician do both the color purity and convergence adjustments. Fee is much less than paying for complete job by TV technician.



CB Servicing Simplified

By Bill Britton

□ Because almost all CB transceivers (with the possible exception of high performance frequency synthesis models) do not use highly sophisticated circuitry, it takes just a few relatively inexpensive instruments—and common sense—to handle most of the problems you're likely to run across. It's only when you want to take on the responsibility (and extra fees) of frequency measurement that specialized test gear is required.

Eyeball Checkout. As in all electronics servicing, the first checks should be made with the eyes; just a few careful glances can save a lot of unnecessary troubleshooting. All connecting cables such as power and antenna leads should be inspected for fraying, broken strands, and complete breaks.

(Many is the CB rig that is repaired by simply replacing the power cord that has the conductors broken under the insulation.) If the transceiver's power cord has an in-line fuseholder, check the wire where it enters the holder. All too many manufacturers use solid wire for the mobile power leads, and solid wire tends to break at a bending point.

And don't forget to check the fuse. It's not uncommon for a fuse to become "fatigued" and open for no apparent reason. If a replacement fuse blows, check for a shorted tube or transistor. Tubes can be checked in a tube-checker; transistors can be checked by touching the transistor case (a shorted transistor generally runs relatively hot). *(Turn page.)*

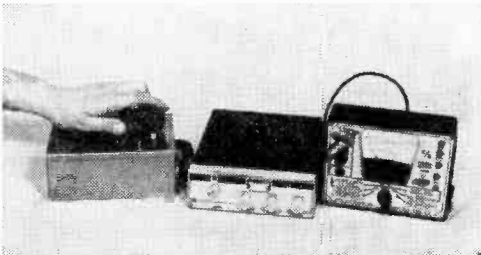

Placing mike on top of speaker emitting steady tone saves talking when checking modulator.

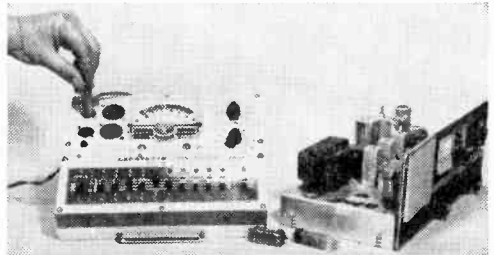

Most CB troubles are solved by replacing bad tubes. When in doubt, try a new tube anyway.

If the fuse blows only on the mobile power supply you'll have to check the mobile supply power components—the vibrator (if used) and its associated capacitor filters (if any) or the switching transistors.

Should eyeball checks fail to reveal the nature of the breakdown, start with the most basic of servicing techniques—a complete tube check. (90% of all service work is simply a replacement tube). But keep in mind that tube-checkers aren't infallible. If a tube tests *good* but the pointer moves erratically when the tube is tapped, or if the pointer wavers, try a new tube, anyway. Tubes used in RF service have been known to check out okay in a tube-tester but still fail to operate in a transceiver.

Troubleshooting. While a CB transceiver is more complex than an ordinary AM radio, servicing is somewhat simplified because the circuitry is arranged in interdependent blocks (see our diagram). The power supply excepted, the failure of one block often doesn't cause the failure of another block. For example, in our block-diagram transceiver, failure in the IF amplifier section wouldn't prevent the transmitter from functioning. Similarly, failure in the transmitter wouldn't interfere with reception.

What happens if the modulator fails? Simple—you couldn't receive and you couldn't modulate, but you *could* transmit a "dead carrier."

See the logic to the *block system* of CB servicing? You use the working circuits as signposts to the defective circuits.

Try your hand on a few typical CB service problems to get the hang of block cir-

cuits. Tackle this problem first: The customer complains of no reception. What is your first troubleshooting procedure? If you said test for modulated RF output you are correct. Here's why.

If the transmitter can be modulated it shows that the power supply and the audio amplifier/modulator are working. Therefore, you have eliminated the audio section as a probable cause of trouble, and the breakdown in the receiver must be between the antenna and the detector.

Here's another. The complaint is no modulation. What's your first check? You're right if you try the mike preamp. If the transmitter is working as evidenced by a "dead carrier," and the receiver is working, you know that the section of the audio system common to the receiver and transmitter is okay. Referring to the block diagram you see that there is a preamplifier which is used only for transmitting. The logical place to look for trouble then is in the preamplifier.

And how about this one? Complaint is that the entire transceiver is inoperative but that the tubes light. You can't get any reception, get nothing through the PA output, and the transmitter fails to budge the RF output meter. Where to look first? Right, the power supply, since it's common to all circuits in the transceiver.

Test Gear. Once the defective circuit is located, you've got to get in there and find the exact component(s) that's defective. Best instrument for this job is a VTVM. Why not a VOM? Because a VOM's internal resistance can seriously load the RF, IF, and oscillator circuits in a tube transceiver and virtually all the circuits in a solid-state model. On the other hand, a VTVM with its very high DC probe resistance (generally about 11 megohms) won't affect critical circuits. In fact, you can even measure DC on the

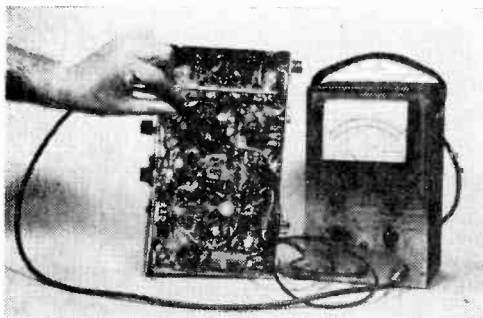

For the serious do-it-yourselfer, a VTVM is very advantageous for accurate measurements of critical RF circuitry in CB gear.

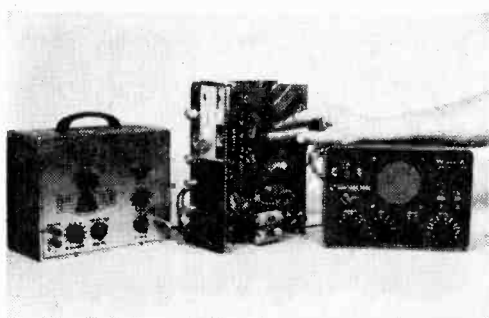

For the really tough dogs, using a signal generator and a signal tracer provides a sure-fire route to pinpointing the problem.

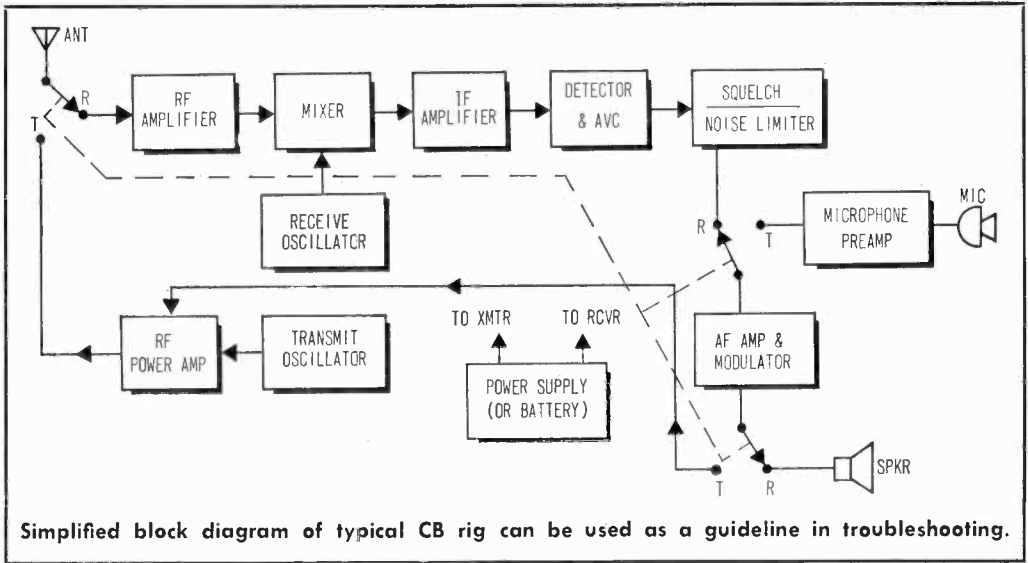

oscillator plate without detuning the oscillator.

While a DC voltage and resistance analysis will often eventually locate the trouble, it's a time-consuming way to do it. Receivers can generally be quickly serviced by signal tracing. For example, feed an RF signal into the antenna input, and then, using an RF/AF signal tracer, you trace the signal from the plate of the RF amplifier to the speaker.

At some point you will lose the signal—and the defect then lies between that point (say the plate of an IF amplifier) and the previous check point where you heard the signal in the tracer (say the grid of the IF amplifier). You then have the trouble pinpointed and a few DC and resistance checks should turn up the defective component(s).

The transmitter can be similarly "traced," though the signal source and the signal tracer are different. The signal source is the oscil-

lator itself. The signal tracer is an RF probe connected to the VTVM that indicates RF in terms of DC voltage reading. Starting at the oscillator plate you move the RF probe towards the antenna. The defect is between the point where the VTVM fails to indicate and the previous point which resulted in a meter reading.

The Dirt Problem. Quite often, extensive troubleshooting will turn up nothing more spectacular than a speck of dirt. Just a little dirt on an exposed relay terminal (the T/R relay) is all it takes to knock out the DC supply to a receiver section, or prevent the RF from getting from the transmitter final to the antenna.

Relays are best cleaned with a burnishing tool, a specially etched strip of metal that will remove dirt and corrosion from relay contacts without destroying the contact. Never use sandpaper to clean relay (or

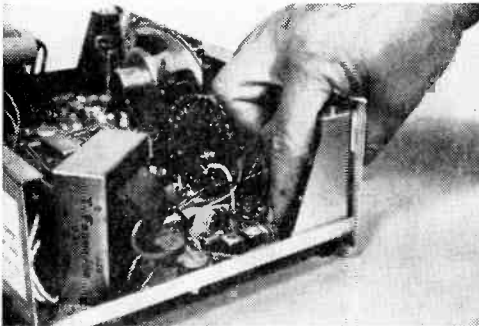

Shorted transistors tell on themselves by heating up. For this reason, a limber finger can locate shorted transistors in a jiffy.

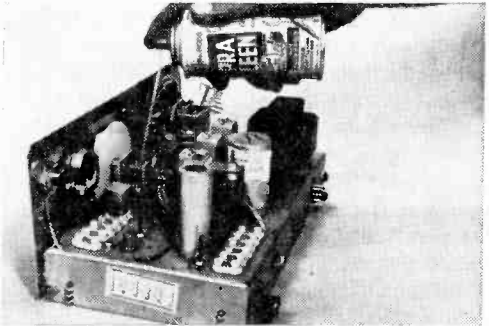

Contact cleaner in a spray can is great for cleaning up dirty switch contacts; just spray on while flipping switch a couple times.

switch) contacts; this can result in pitted contacts, which will in turn cause more pitting until the relay contacts fuse together.

Noisy volume controls should always be replaced, since noise is generally an indicator of a worn carbon element, and the noise is bound to return if the control is just cleaned. But in a pinch, there's nothing wrong with shooting control cleaner under the control cover to stop the noise. Just don't be surprised if the noise returns. (When you're doing a paying job always replace a noisy control.)

The microphone cable of heavily used transceivers often develops "opens" under the outer insulation at the point where the cable leaves the microphone and where it enters the mike connector or chassis (these are the maximum stress points). If you suspect the mike or its connector, simply key the transmitter, and while monitoring the signal on another transceiver or modulation monitor, place your finger on the grid of the mike preamplifier. If you hear hum, either the mike is defective or the cable is broken. (A loud hum with the mike connected is often caused by a broken shield lead.)

The Elusive Ones. Remember, too, that poor transceiver performance isn't always caused by a defective component. Quite often, poor sensitivity and low RF power output is due to normal component aging, which in turn results in detuning of tuned RF circuits. If you suspect the receiver has drifted out of alignment, do a complete alignment job following the manufacturer's procedure. (Never try to "trim" one or two stages). If an IF stage's tuning has drastically changed, it's likely the remaining IF and RF amplifiers have also drifted. Once you've got the signal generator on the bench it's just as easy to do a full alignment as a "trimming."

While any service grade signal generator can be used for alignment, a calibrated-output generator must be used if you want to compare the actual receiver sensitivity against the manufacturer's claims or original performance specifications.

Any transceiver service job should end with a complete tuning and check for the transmitter. Tuning, of course, is easily accomplished by connecting a combination

dummy-load/wattmeter to the antenna jack and tuning the transmitter for 5 watts RF plate input power. The RF output power for 5 watts input should then be compared against original performance. If it is more than 1/2 watt below specs, chances are the transmitter needs something more than just a tuning.

Since transmitter tuning often affects the oscillator output frequency, a transmitter frequency check should be made after the final tune-up. For this job a CB frequency meter is an absolute must. There is no other way to measure frequency, unless you're willing to spend a thousand dollars for a digital counter.

A receiver cannot be used for frequency measurements. While some CBers consider the transmitter on-frequency if its signal causes another transceiver's S-meter to "peak," there is obviously no relationship between the S-meter reading and a transmitter's frequency. In fact, the S-meter "peak" will be determined by the receiver's alignment, not by the transmitter.

Complex Transceivers. As we've indicated, servicing of the more or less common transceiver—using separate receive and transmit oscillators—can be tackled by anyone with a reasonable degree of service skill and experience. However, the new frequency synthesized high-performance transceivers are generally best left to an authorized service center on account of the frequency synthesizer and selective IF filters.

Of course, not all high-performance transceivers are beyond the capabilities of service-grade instruments. Even so, the CB technician should be certain *before* starting any service procedure that his instruments conform to the transceiver manufacturer's minimum standards. ■

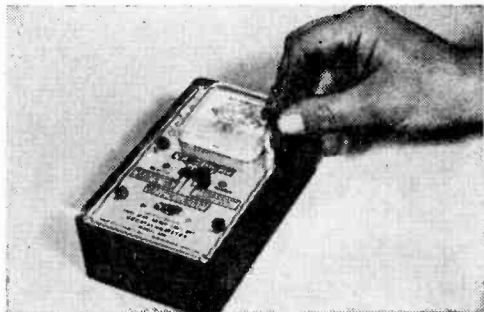

CB crystal checkers don't tell you if crystal is really hot—best way is to compare reading of suspect crystal against good one.

CLASSIFIED Market Place

FOR BIGGER PROFITS! NEW CAREER OPPORTUNITIES!
READ AND REPLY TO THESE CLASSIFIED ADS

Classified Ads 55¢ per word, each insertion, minimum 10 words, payable in advance. To be included in the next available issue of RADIO-TV REPAIR, copy must be in our New York Office by Nov. 10th. Address orders to C. D. Wilson, Manager, Classified Advertising, RADIO-TV REPAIR, 505 Park Ave., New York, N. Y. 10022.

ADDITIONAL INCOME

MAKE Your Classified Ad Pay. Get "How To Write a Classified Ad That Pulls." Includes certificate worth \$2.00 towards classified ad in Radio TV Repair. Send \$1.00 to C. D. Wilson, Science & Mechanics, 505 Park Ave., New York, New York 10022.

AUTHOR'S SERVICE

PUBLISH your book! Join our successful authors publicity advertising promotion, beautiful books. All subjects invited. Send for free manuscript report and detailed booklet. Carlton Press, Dept. SMH, 84 Fifth Avenue, New York 10011.

BOOKS & PERIODICALS

PERPETUAL Motion Journal 35¢. 1616 S. Compton, Desk G, St. Louis, Mo. 63104.

FREE List—Popular Books. Business Opportunity. Personal. Wilson Sales, Box 5025, Mobile, Ala. 36605.

CATALOG of all Science & Mechanics Craftprints. Send 25¢ to cover postage and handling to Craftprint Div., Science & Mechanics, 505 Park Ave., New York 10022.

BUSINESS OPPORTUNITIES

I MADE \$40,000.00 a year by Mailorder! Helped others make money! Start with \$10.00—Free Proof! Torrey, Box 318-T, Ypsilanti, Michigan 48197.

FREE BOOK "990 Successful Little-Known Businesses." Fascinating! Work home! Plymouth 111-J, Brooklyn, N. Y. 11218.

FOR Business Opportunities—read Science & Mechanics, 12 issue \$4.00. Write Science & Mechanics, 505 Park Ave., New York, N. Y. 10022.

COINS, CURRENCY & TOKENS

LINCOLN Cent. 1955-S, 25¢. Free List. Stevens, Box 212-A, Plainview, N. Y. 11803.

EARTHWORMS

BIG Money Raising Fishworms and Crickets. Free Literature. Carter Farm-O, Plains, Georgia 31780.

THERE is no charge for the Zip Code. Please use it in your Classified Ad.

EDUCATION & INSTRUCTIONS

FCC License and Associate Degree correspondence/residence courses. School bulletin free. Grantham Institute of Electronics, 150 N. Western Ave., Hollywood, California 90027.

EMPLOYMENT INFORMATION

AUSTRALIA Wants You! Government Assisted Passage. Unlimited Opportunities. Latest Government Information \$1.00. Austco, Box 3623-CB, Long Beach, California 90803.

FOR THE HOME

EXOTIC. Novel Indoor Plants and Flowers. Details, Ed's International, 1608 —80th, Chicago, Ill. 60620.

PRACTICAL tips for home, garden and workshop, are in "1001 How-To Ideas." A high value reference for all craftsmen. Send \$1.00 for your copy includes Postage, to 1001 How-To Ideas, 505 Park Ave., New York, N. Y. 10022.

INVENTIONS WANTED

WE either sell your invention or pay cash bonus. Write for details. Universal Inventions, 298-10 Marion, Ohio 43302.

MONEYMAKING OPPORTUNITIES

NEED Money? Amazing new Booklet—just printed—shows hundred ways to get it. Be first. Rush 25¢. Lynton House, Box 1715, Lynwood, Calif. 90262.

START Profitable Business in spare time. Investigate many money-making agency and franchise opportunities. Send 10¢ for sample copy of Income Opportunities Magazine, 505 Park Avenue, New York, 10022, Dept. S.

PERSONAL

BILL Problems? Poor credit no trouble. Not a loan company. Send for free application. Automatic Acceptance, 318DC Broadway Blvd., Reno, Nev. 89502 or 307DC Focasset Ave., Providence, R. I. 02909.

FOR the best in Mystery Reading—Subscribe to Ellery Queen's Mystery Magazine, 505 Park Ave., New York, N. Y. 10022. Send \$2.49 for 10 issues.

RADIO & TELEVISION

McGEE Radio Company. Big 1966-1967 Catalog Sent Free. America's Best Values. Hi-Fi. Amplifiers, Speakers, Electronic Parts. Send Name, Address and Zip Code Number to McGEE Radio Company, 1901 McGee Street, Dept. RTV, Kansas City, Missouri 64108.

FREE Catalog. Electronics parts, tubes, Wholesale. Thousands of items. Unbeatable prices. Arcturus Electronics-RT, 502 22nd St., Union City, N. J. 07087.

CANADIANS—Giant Electronic Catalogs, Hi-Fi, Shortwave, Ham, CB, Rush \$1.00. ETCO, Dept. RT, Box 741, Montreal, Canada.

POLICE—Fire—Aircraft Calls on your Broadcast Radio! Tune the Band! Free Catalog. Salch Company, Woodsboro, SMTR, Texas 78393.

REMAILING SERVICE

CHICAGO Remails 25¢. Monthly \$3.00. Nomarch, 7505 Jeffrey, Chicago, Ill. 60649.

SCIENCE EXPERIMENTS

SCIENCE Experimenter—the magazine dedicated to the youth who is interested in experimentation. Send \$1.00 includes Postage & Handling to Science Experimenter, 505 Park Ave., New York, N. Y. 10022.

SONGWRITERS

POEMS Wanted for musical setting and recording. Send poems. Free examination. Crown Music, 49-SC, West 32, New York 10001.

SPECIAL SERVICES

LOOK Men—especially Golf Players Cut your shoe cost. Send 25¢ for details. Delph's Leather Products, Tamaqua, Pennsylvania 18252.

STAMP COLLECTING

NEW U.S. SipeX Souvenir Sheet. 10¢. Free List. Bedrin, 250-K Fulton, Hempstead, New York 11550.

START YOUR OWN BUSINESS

UP to 90¢ Profit On Each \$1.00 Sale. Details 25¢. Carpenter, 2907-C West 39th Place, Chicago, Ill. 60632.

For Greater Classified Profits

WHY NOT TRY THIS NEW

combined classified ad medium

Your classified ad will appear in SCIENCE & MECHANICS MAGAZINE as well as in a minimum of three other SCIENCE & MECHANICS PUBLICATIONS. Write now for information to C. D. Wilson, Manager, Classified Advertising, SCIENCE & MECHANICS, 505 Park Ave., New York, N. Y. 10022.

Most from B & W TV

Continued from page 22

trols for adjusting the correct width of the picture. These are the width and horizontal drive controls. If the picture is too wide or too narrow, first adjust the width control until the picture approaches as near as possible the correct width. (Fig. 21 shows a picture that is too narrow.) Then adjust the drive control until the picture fits the mask. If the drive control is incorrectly adjusted to give excessive drive, a vertical white line (overdrive line) will appear on the screen. Fig. 22 shows the effects of excessive drive on the picture.

Height (or vertical size) Control. Fig.



Fig. 24. Flat-topped circle can be made round again by adjusting both the vertical linearity and the vertical height controls together.

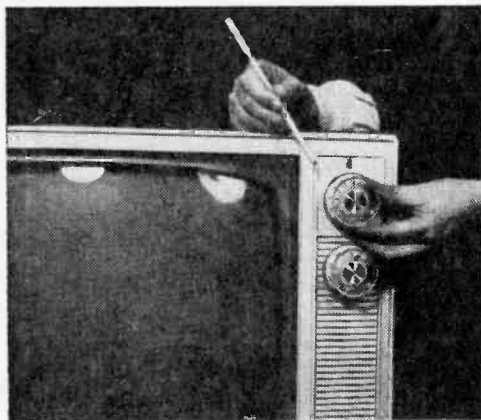

Fig. 25. Final tune-up consists of adjusting tuner slugs to center range of fine-tuning.

23 shows the effect on the picture of an incorrect adjustment of the vertical size or height control. In this illustration the picture is too narrow from top to bottom, but symmetrical with respect to the center.

Vertical Linearity Control. Fig. 24 shows a picture in which the vertical linearity control is misadjusted. In this case the picture is cramped from top to center while the bottom half is elongated. To adjust the vertical linearity control, rotate the shaft until the picture dimensions from top to center and from bottom to center are the same. To do this it is usually necessary to adjust the vertical linearity and vertical size controls alternately until the picture is linear and fits the screen.

The End (!). If you've taken a half hour or so to make various adjustments, the set is warm enough for the next step. By retuning slugs in the TV tuner's local oscillator, you can shift the fine-tuning control so it centers on each channel. (This is not necessary on late models that have pre-set or "memory" fine tuning.)

Begin by pulling off both main and fine-tuning knobs (VHF only), as shown in Fig. 25. This should reveal a small access hole in front of the tuner. Turn to your highest channel and set the fine-tuning shaft at the center of its rotation. Insert a non-metallic screwdriver into the access hole and tune the slug for best picture and sound, repeating this for every channel you receive. (Temporarily put back the main channel knob to flip to the next channel, but leave fine tuning undisturbed.)

Tired of all that tuning and adjusting? If so, our special televised message in Fig. 26 should prove reassuring. ■



Fig. 26. The final result of these adjustments is a great picture that's the living end.

Mail This Card Today-->

FREE LAFAYETTE 1968 CATALOG



Over
500
Pages

Featuring Everything in Electronics for
• HOME • INDUSTRY • LABORATORY
from the "World's Hi-Fi & Electronics Center"

Use LAFAYETTE'S Easy-Pay
Budget Plan **NO MONEY DOWN** . . .
Up to 24 Months to Pay

Satisfaction guaranteed
or Money Refunded

--- Mail This Card Today for Your Friend -->

STORE LOCATIONS

- | | | |
|-----------------|-------------|-----------------------|
| NEW YORK | NEW JERSEY | MASSACHUSETTS |
| Bronx | Manhattan | Newark |
| Brooklyn | Scarsdale | Paramus |
| Jamaica | Syosset | Plainfield |
| PENNSYLVANIA | CONNECTICUT | WASHINGTON, D.C. Area |
| King of Prussia | Hamden | Falls Church, Va. |
| Philadelphia | W. Hartford | Mt. Rainier, Md. |
| Pittsburg | | |

*Mail the Coupon Today for Your
FREE 1968 Lafayette Catalog 680*

LAFAYETTE Radio ELECTRONICS
Dept. RTR-7 P.O. Box 10
Syosset, L.I., N.Y. 11791

Send me the Free 1968 Lafayette Catalog 680

Name

Address

City State Zip

(Please Give Your Zip Code No.)

Mail This
Card Today
For Your

FREE!

1968 Lafayette Catalog 680

Dept. RTR-7

Name

Address

City

State

Zip

(Please Give Your Zip Code No.)

PLACE
STAMP
HERE

LAFAYETTE RADIO ELECTRONICS

P.O. BOX 10
SYOSSET, L.I., N.Y. 11791

LAFAYETTE
RADIO ELECTRONICS
 P.O. BOX 10
 SYOSSET, L.I., N.Y. 11791

PLACE
 STAMP
 HERE

Dept. RTR-7

Name _____

Address _____

City _____

State _____

Zip _____

(Please Give Your Zip Code No.)

FREE!



Mail The Card Today for Your
FREE!
 LAFAYETTE 1968 Catalog 680

Mail This Card Today For Your

FREE!

1968 Lafayette
 Catalog 680



Over
500
 Pages



Shop At the "World's Hi-Fi
 & Electronics Center"
 For Widest Selection, Low Prices

Stereo Hi-Fi • Citizens Band • Ham Gear • Tape
 Recorders • Test Equipment • TV and Radio
 • Phonographs, Accessories • Intercoms and PA
 • Closed Circuit TV • Tubes and Parts • Cameras
 • Auto Accessories • Musical Instruments • Tools
 • Books

Featuring Everything in Electronics for
 • HOME • INDUSTRY • LABORATORY
 from the "World's Hi-Fi & Electronics Center"

NOW - REVOLUTIONARY NEW



Electronic Miracle
 of the Space Age



New! Solid State "IC"
 Stereo Receivers



New! Revolutionary "IC"
 2-Way Radios
 "IC" (Integrated Circuit)



New!
 Dyna Com
 Series
 Super
 Walkie-Talkies



New! Musical
 Instruments and
 Accessories

Do A Friend A Favor . . .

Have a friend interested in hi-fi or electronics? Send us his name and address and we will send him his own personal copy of the 1968 Lafayette Catalog 680.

FREE! MAIL THE CARD TODAY!

BUILD YOUR OWN RADIO

CIRCUITS AT HOME
with the New Improved
PROGRESSIVE RADIO "EDU-KIT"®

only
\$26.95

A Practical Home Radio Course

Now Includes

- ★ 12 RECEIVERS
- ★ 3 TRANSMITTERS
- ★ SQ. WAVE GENERATOR
- ★ SIGNAL TRACER
- ★ AMPLIFIER
- ★ SIGNAL INJECTOR
- ★ CODE OSCILLATOR

- ★ No Knowledge of Radio Necessary
- ★ No Additional Parts or Tools Needed
- ★ EXCELLENT BACKGROUND FOR TV
- ★ **SCHOOL INQUIRIES INVITED**
- ★ Sold In 79 Countries



Reg. U.S.
Pat. Off.

Training Electronics Technicians Since 1946

FREE EXTRAS

• SET OF TOOLS

- SOLDERING IRON
- ELECTRONICS TESTER
- PLIERS-CUTTERS
- VALUABLE DISCOUNT CARD
- CERTIFICATE OF MERIT
- TESTER INSTRUCTION MANUAL
- HIGH FIDELITY GUIDE & QUIZZES
- TELEVISION BOOK & RADIO TROUBLE-SHOOTING BOOK
- MEMBERSHIP IN RADIO-TV CLUB: CONSULTATION SERVICE, FCC AMATEUR LICENSE TRAINING
- PRINTED CIRCUITRY

YOU DON'T HAVE TO SPEND HUNDREDS OF DOLLARS FOR A RADIO COURSE

The "Edu-Kit" offers you an outstanding PRACTICAL HOME RADIO COURSE at a rock-bottom price. Our Kit is designed to train Radio & Electronics Technicians, making use of the most modern methods of home training. You will learn radio theory, construction practice and servicing. THIS IS A COMPLETE RADIO COURSE IN EVERY DETAIL.

You will learn how to build radios, using regular schematics; how to wire and solder in a professional manner; how to service radios, using the standard type of punched metal chassis as well as the latest development of Printed Circuit chassis.

You will learn the basic principles of radio. You will construct, study and work with RF and AF amplifiers and oscillators, detectors, rectifiers, test equipment. You will learn and practice code, using the Progressive Code Oscillator. You will learn and practice trouble-shooting, using the Progressive Signal Tracer, Progressive Signal Injector, Progressive Dynamic Radio & Electronics Tester, Square Wave Generator and the accompanying instructional material.

You will receive training for the Novice, Technician and General Classes of F.C.C. Radio Amateur License. You will receive Transmitter, Square Wave Generator, Code Oscillator, Signal Tracer and Signal Injector circuits, and learn how to operate them. You will receive an excellent background for television, Hi-Fi and Electronics.

Absolutely no previous knowledge of radio or science is required. The "Edu-Kit" is the product of many years of teaching and engineering experience. The "Edu-Kit" will provide you with a basic education in Electronics and Radio, worth many times the low price you pay. The Signal Tracer alone is worth more than the price of the kit.

THE KIT FOR EVERYONE

You do not need the slightest background in radio or science. Whether you are interested in Radio & Electronics because you want an interesting hobby, a well paying business or a job with a future, you will find the "Edu-Kit" a worth-while investment. Many thousands of individuals of all

ages and backgrounds have successfully used the "Edu-Kit" in more than 79 countries of the world. The "Edu-Kit" has been carefully designed, step by step, so that you cannot make a mistake. The "Edu-Kit" allows you to teach yourself at your own rate. No instructor is necessary.

PROGRESSIVE TEACHING METHOD

The Progressive Radio "Edu-Kit" is the foremost educational radio kit in the world, and is universally accepted as the standard in the field of electronics training. The "Edu-Kit" uses the modern educational principle of "Learn by Doing." Therefore you construct, learn schematics, study theory, practice trouble shooting—all in a closely integrated program designed to provide an easily-learned, thorough and interesting background in radio.

You begin by examining the various radio parts of the "Edu-Kit." You then learn the function, theory and wiring of these parts. Then you build a simple radio. With this first set you will enjoy listening to regular broadcast stations, learn theory, practice testing and trouble-shooting. Then you build a more advanced radio, learn more advanced theory and techniques. Gradually, in a progressive manner, and at your own rate, you will find yourself constructing more advanced multi-tube radio circuits, and doing work like a professional Radio Technician.

Included in the "Edu-Kit" course are Receiver, Transmitter, Code Oscillator, Signal Tracer, Square Wave Generator and Signal Injector Circuits. These are not unprofessional "breadboard" experiments, but genuine radio circuits, constructed by means of professional wiring and soldering on metal chassis, plus the new method of radio construction known as "Printed Circuitry." These circuits operate on your regular AC or DC house current.

THE "EDU-KIT" IS COMPLETE

You will receive all parts and instructions necessary to build twenty different radio and electronics circuits, each guaranteed to operate. Our Kits contain tubes, tube sockets, variable electrolytic, mica, ceramic and paper dielectric condensers, resistors, tie strips, hardware, tubing, punched metal chassis, Instruction Manuals, hook-up wire, solder, selenium rectifiers, coils, volume controls and switches, etc.

In addition, you receive Printed Circuit materials, including Printed Circuit chassis, special tube sockets, hardware and instructions. You also receive a useful set of tools, a professional electric soldering iron, and a self-powered Dynamic Radio and Electronics Tester. The "Edu-Kit" also includes Code Instructions and the Progressive Code Oscillator, in addition to F.C.C. Radio Amateur License training. You will also receive lessons for servicing with the Progressive Signal Tracer and the Progressive Signal Injector, a High Fidelity Guide and a Quiz Book. You receive Membership in Radio-TV Club, Free Consultation Service, Certificate of Merit and Discount Privileges. You receive all parts, tools, instructions, etc. Everything is yours to keep.

PRINTED CIRCUITRY

At no increase in price, the "Edu-Kit" now includes Printed Circuitry. You build a Printed Circuit Signal Injector, a unique servicing instrument that can detect many Radio and TV troubles. This revolutionary new technique of radio construction is now becoming popular in commercial radio and TV sets.

A Printed Circuit is a special insulated chassis on which has been deposited a conducting material which takes the place of wiring. The various parts are merely plugged in and soldered to terminals.

Printed Circuitry is the basis of modern Automation Electronics. A knowledge of this subject is a necessity today for anyone interested in Electronics.

Progressive "Edu-Kits" Inc., 1186 Broadway, Dept. 509DK, Hewlett, N. Y. 11557

UNCONDITIONAL MONEY-BACK GUARANTEE

ORDER FROM AD—RECEIVE FREE BONUS RADIO & TV PARTS JACKPOT WORTH \$15

- Send "Edu-Kit" postpaid. I enclose full payment of \$26.95.
- Rush "Edu-Kit" C.O.D. I will pay \$26.95 plus postage.
- Send me FREE descriptive literature concerning "Edu-Kit."

Name
 Address
 City and State Zip

PROGRESSIVE "EDU-KITS" INC.

1186 Broadway, Dept. 509DK, Hewlett, N. Y. 11557

Major TV Guide Magazine Reports 50 to 75,000 Servicemen Needed Now in Nationwide Shortage . . .

Fabulous Profit Opportunity for Repairs!

FIRST-QUALITY RADIO-TV RECEIVING TUBES ... BRAND-NEW, FULLY-WARRANTED



Yes, it's true! There's a critical shortage of professionally-trained electronic technicians. From 50,000 to 75,000 are needed today, and in ten years the need may run as high as 400,000!

What a fantastic opportunity for you!
For if you know your way around a circuit of either a radio or television set, know how to test tubes and make simple repairs, you can expand your income right now for just about as much as you want! Now, the combination of a shortage of technicians . . . and the chance to buy replacement tubes at this low flat price of only \$1 . . . can make a big difference in your life.

Thousands of "do-it-yourselfers," hobbyists, technicians, even professional repairmen have come to rely on Universal Tube's "Buy by Mail and Save."

Look at these Fabulous Advantages by Buying from Universal:

- Practically all tube types now in use in black & white & color sets
- All discount-priced at only \$1 each
- All orders shipped First Class same day received
- All tubes Brand-New, Warranted in Writing for a full 24 months
- All tubes first quality only

You can be the Johnny-on-the-Spot with electronic repairs you can make at a big profit. You can test tubes you think are defective, order replacements, get them fast . . . and satisfy your friends and neighbors.

UNIVERSAL TUBE COMPANY, Ozone Park Station, N. Y. 114¹⁷

USE THIS COUPON FOR FAST SERVICE TODAY—

UNIVERSAL TUBE CO. Dep't. TVR-97
Please ship me tubes as follows:

QUANTITY	TYPE	QUANTITY	TYPE
.....
.....
.....
.....
.....
.....
.....
.....
.....
.....

Also send Tube Tester @ \$35.90 ea. ppd.
Please add 50¢ to total order for postage and handling.

I enclose \$.....
NAME.....
ADDRESS.....
CITY..... STATE..... ZIP.....

NOTE: Minimum order for tubes @ \$1 ea.—10 tubes.
Less than 10 tubes—\$1.50 each.

EXTRA! Model 213 TUBE TESTER
Portable . . . Modern . . . Flexible

Checks all the newest 10- and 12-prong tubes. Also checks Magic Eye, Voltage Regulator, Hi-Fi Tubes. Comes complete with instructions. Includes smart carrying case. Only \$35.90 pp. (as shown), without case only \$32.90 ppd.

ONLY \$35⁹⁰
PPD.
(as shown)