

**Radio-  
Electronics**

# Special Projects

The magazine for people who build electronic projects

#7

\$2.25  
SUMMER  
1983

48784

## SYNDLE

The Electronic Candle  
that flickers like  
a Wax Taper

## MAKE PRO CABINETS

for Home-Brew Projects

## Build it for FUN

3-Band Shortwave Converter

Electronic Slot Machine

Preamplifier for moving coil

Phono Cartridge

Soundbox-80 for Computer

Game Sounds

Prototyping Power Supply

## Test Gear Projects

Ribbon-Cable Tester

Meg-O-Dapter for DVM

Mini-Audio Generator

Scope Calibrator

Single Sweeper One Blanker



See page 4



See page 10



See page 61



See page 90



See page 51



See page 42



See page 4

## PLUS....

**JBL Sound System  
for the musician!**



# MAKE THE A P CONNECTION

NOW YOUR SINGLE SOURCE FOR ALL YOUR ELECTRONIC  
CIRCUIT BUILDING, TESTING AND INTERCONNECTION NEEDS.

**Introducing Our Complete Line of  
Interconnection Products and  
Accessories...Featuring Our New  
Insulation Displacement Connectors.**

No matter what your requirements in  
interconnection products, we have just what  
you are looking for. DIP, Socket, and Card-  
Edge IDC connectors, all styles and sizes of  
Headers and D-Submin in both IDC and  
solder versions. Also flat cable in both gray  
and rainbow in a wide range of widths.

**Brand New Low Cost IDC Assembly Tool**  
So sensationally low-priced it won't put a  
"crimp" in your budget.

**Famous A P Quality and Price**  
Every A P product is built with time-proven  
quality and dependability. And best of  
all...each one is very competitively priced.

## **Your Single Source**

A P makes hundreds of electronic circuit  
building and testing devices as well as  
a complete line of interconnection  
products and accessories. Everything from  
Breadboards, Super-Strips, Test Clips  
and Poweraces to Headers, Connectors  
and Cable.

**A P has it all for you!**

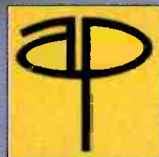
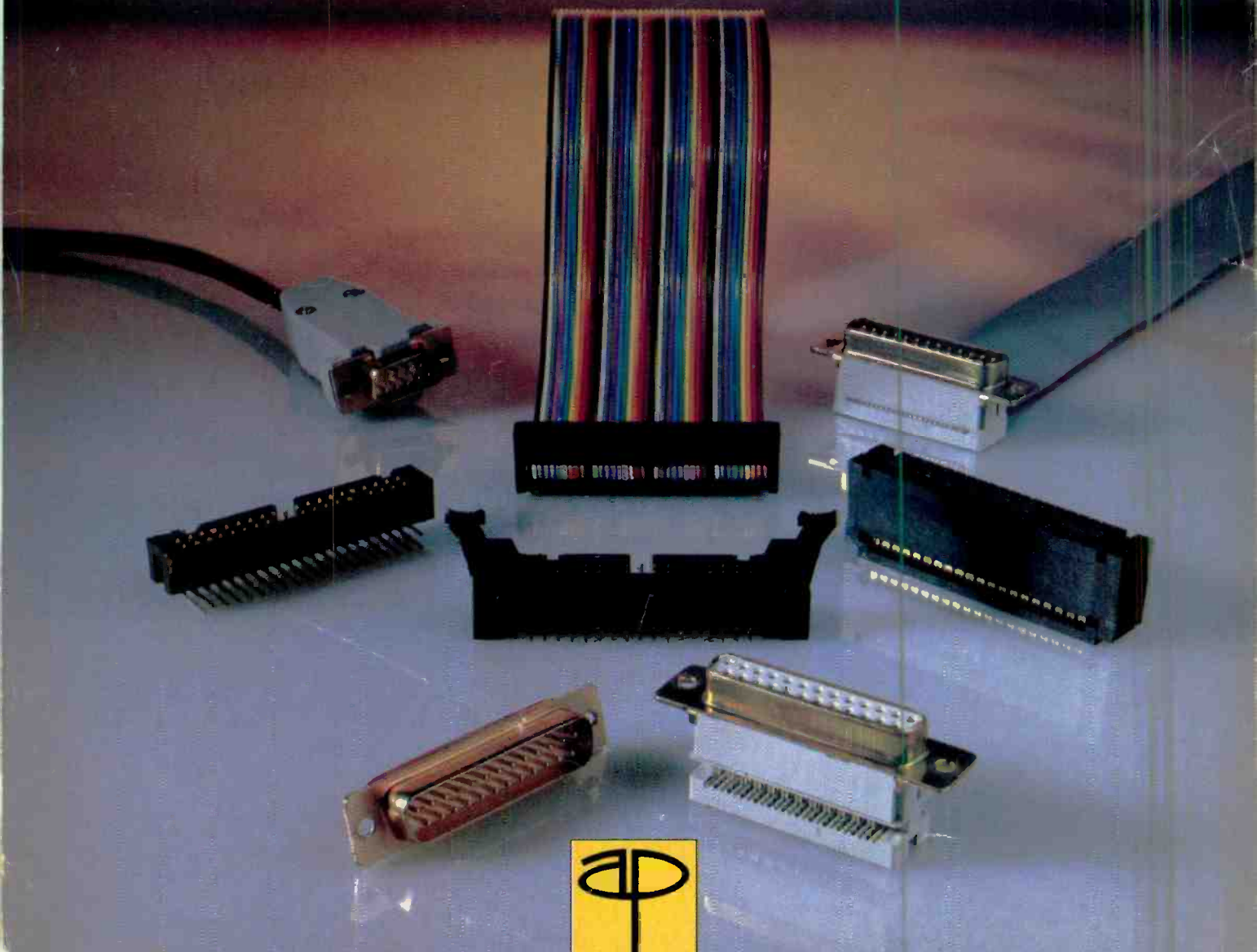

A P PRODUCTS INCORPORATED • 9450 Pineneedle Drive • P.O. Box 540 • Mentor, Ohio 44060 • (216) 354-2101 • TWX: 810-425-2250  
In Europe, contact A P PRODUCTS GmbH • Baumlesweg 21 • D-7031 Weil 1 • West Germany

For the name of your nearest distributor call Toll Free 800-321-9668. (In Ohio call collect 216-354-2101.)

CIRCLE 801 ON FREE INFORMATION CARD

# Radio-Electronics special Projects

The Magazine for people who build electronic gadgets!

#7  
SUMMER 1983

## You made us believers!

Editors sit in ivory palaces and conjure up ideas, stories, features, and everything else that goes into magazines. Far too often, an editor will forget about the real world his readers live in and drift off into some fantasy world that is not meaningful to them. Here at **Special Projects** we realize that human attribute, and work hard to avoid the pitfalls that grow in every editor's path.

In an editorial discussion period two issues back, it was decided that our readers wanted to receive **Special Projects** via subscription—let the mailman do the walking. We had no hard facts to back up our dream, but we believed we were correct in that assumption. After a few inquiries via the telephone, we asked our readers in the last issue to advise us as to what we should do. You made us believers in ourselves! You voted overwhelmingly for the subscription option. So be it!

If you wish to subscribe to **Special Projects**, we suggest you turn to page 7, where complete subscription information and a coupon to facilitate ordering is available.

For the remainder of 1983, **Special Projects** will be a quarterly magazine. We are still looking into the possibility of publishing more frequently, but that move has to be based on so many facts, and inputs from so many corners, that the decision to remain quarterly will have to stand for the present. One source of input is you, our readers. Let's hear from you. *Should* we continue to publish quarterly? Or, should we step up to bi-monthly—six issues a year? Your input makes our decisions meaningful. Please help us.

Now, all we ask you to do is turn the page and get into this issue of **Special Projects**. Enjoy reading it, and enjoy building projects, as much as we have enjoyed preparing the issue for you. The Editor's Choice for this issue is *Syndle—the Electronic Candle*, which appears on page 61. If you'd like to learn Morse code, turn to page 93 for complete plans for a code-practice processor that we call *CPP1*. And, there is lots more to pick from that'll make **Special Projects** your benchside manual for many months to come. Happy building.



Julian S. Martin, KA2GUN  
Managing Editor

Radio-Electronics Special Projects, (ISSN 0730-7616) published quarterly by Gernsback Publications, Inc., 200 Park Avenue South, New York, NY 10003. Phone 212-777-6400. Four-issue subscription rate is \$9.00—U.S. funds only. Canada and Mexico subscribers add \$3.00 for postage. All others add \$7.00. Mail all subscription orders, address changes, correspondence and Postmaster Notices of undelivered copies (Form 3579) to Special Projects Subscription Service, Suite 1101, 200 Park Avenue South, New York, NY 10003. Single-copy price \$2.25. © 1983 by Gernsback Publications, Inc. All rights reserved. Printed in U.S.A.

A stamped self-addressed envelope must accompany all submitted manuscripts and/or artwork or photographs if their return is desired should they be rejected. We disclaim any responsibility for the loss or damage of manuscripts and/or artwork or photographs while in our possession or otherwise.

As a service to readers, Radio-Electronics Special Projects publishes available plans or information relating to newsworthy products, techniques and scientific and technological developments. Because of possible variances in the quality and condition of materials and workmanship used by readers, Radio-Electronics Special Projects disclaims any responsibility for the safe and proper functioning of reader-built projects based upon or from plans or information published in this magazine.

Hugo Gernsback (1884-1967) founder  
M. Harvey Gernsback, editor-in-chief  
Larry Steckler, CET, publisher  
Art Kleiman, editorial director  
Julian S. Martin, KA2GUN  
managing editor  
Josef Bernard, K2HUF,  
technical editor  
Carl Laron, associate editor  
Brian C. Fenton, assistant editor  
Dan Rosenbloom,  
production manager  
Robert A. W. Lowndes, production  
associate  
Joan Roman, circulation director  
Arline R. Fishman,  
advertising coordinator

Cover photo by Robert Lewis  
Composition and interior design by  
Mates Graphics

### BUSINESS AND EDITORIAL OFFICES

Gernsback Publications, Inc.  
200 Park Ave. S., New York, NY 10003  
President: M. Harvey Gernsback  
Vice President: Larry Steckler

### ADVERTISING SALES

Stanley Levitan  
Radio-Electronics  
200 Park Ave., South  
New York, N.Y., 10003  
212-777-6400

### PACIFIC COAST Mountain States

Marvin Green  
Radio-Electronics  
413 So. La Brea Ave.  
Los Angeles, Ca 90036  
(213) 938-0166

### MIDWEST/Texas/ Arkansas/Okla.

Ralph Bergen  
The Ralph Bergen Co.  
540 Frontage Road—Suite 325  
Northfield, Illinois 60093  
(312) 446-1444



MPA

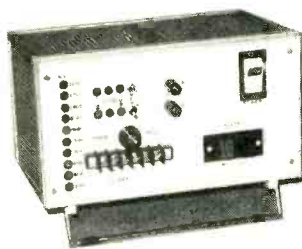

**9  
DIGITAL  
PROTOTYPING  
SYSTEM**

Here's the benchtop project for you! It delivers 5-volts DC that's rock stable, has a LED-bar, current monitor, two logic-probe circuits, and 12 clock frequencies from 0.01 to 170K Hertz.

**20  
SOUNDBOX  
80**

Are your TRS-80 computer game programs as quiet as electrons hitting the monitor's screen? Well, here is a gadget that'll interface with your computer and add sounds as you shoot down aliens.

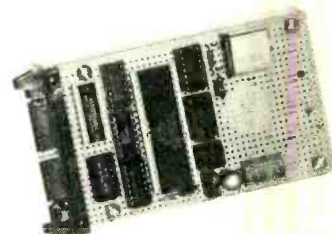

**32  
RIBBON CABLE  
TESTER**

That new flat ribbon cable may look real good but somewhere in one of the end connectors or in between may lurk a short or open circuit that'll put your computer on hold. Our gadget tests the biggest of cables.

**34  
MOCO  
PREAMPLIFIER**

Have you been staying away from moving-coil cartridges because they require very low-noise preamplifiers? Don't—because we have a super low-noise circuit that uses matched quality transistors, that provides the gain you need without hum.



**42  
SINGLE  
SWEEPER ONE**

Is your golden-oldie oscilloscope lacking a built-in, single-sweep, blanking circuit? Then have we got a winner for you! All that the old scope need have is a gate or ramp output, and a Z-axis input—and away you go!

**51  
MINI AUDIO  
GENERATOR**

We tout this one-chip, test-gear project as one that's worth its weight in Hertz's. It can deliver from 2 to 18,000 Hertz with an output up to 10 volts peak-to-peak. And it goes together faster than you can imagine.



**54  
RETROFITTING THE  
SINCLAIR/TIMEX  
COMPUTER FOR A  
STANDARD VIDEO  
OUTPUT**

When the title of a story says as much as this title does, what more can be said than: Turn to page 54 for all the facts?

**58  
ELECTRONIC  
FLASHER**

Here's an opportunity to remove that clicking, stone-age thermo-mechanical turn-signal flasher from your car and add a beeping, solid-state device whose flash frequency is not dependent on engine speed.



**65  
JBL SYSTEM**

This project is more to the liking of a carpenter, but with our complete construction details you can assemble a loudspeaker system especially designed for professional musicians. This 300-watt project is suitable for use with lead guitars, vocalists, and keyboards.

**69  
ELECTRONIC  
SLOT  
MACHINE**

Here's a gaming project that lets you keep the winnings as player or builder—because you own the slot machine. It's a fun project to build.

**75  
MEG-O-DAPTER**

If you are getting into insulation testing, then this project will replace the expensive Megohm meters (called Meggers) at a fraction of the cost. You can test resistance at DC levels as high as 1000 volts at safe current-levels of only 50 to 60 microamperes.

**83  
SCOPE  
CALIBRATOR**

Here are three square-wave voltages—5.0-, 0.5- and 0.05-volts peak-to-peak—that serve as a calibration signal for your scope's low-capacity input probe.



**87  
PRO CABINETS  
FOR HOME-  
BREW  
PROJECTS**

The old breadboard (Mom's chopping board) and the oatmeal box are no longer used to assemble projects.

**92  
EXTRA-LOW-  
POWER  
PILOT LIGHT**

For once, someone has considered the battery drain that pilot lights place on projects. Now, a simple circuit flashes a light-emitting diode.

## 24 CUSTOM SOUND FOR YOUR CAR

That Detroit or Tokyo hunk of iron and plastic you call "transportation" could stand an up-lift in the radio-audio department considering that the old heap is going to pile up more than six-digit mileage.

## 28 MAKE YOUR OWN COMPUTER CABLES

We tell you how to assemble your own multi-lead cables, including those very expensive pre-assembled ribbon jobs, with the greatest of ease.

## 48 SUPER SENSITIVE SIMPLE VOLTMETER

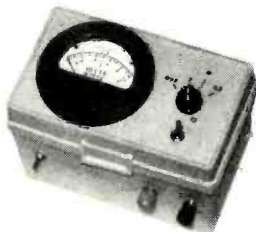

Did you ever think that you could measure the voltage on the AGC bus without interrupting the receiver's circuit action. This test circuit can do it and let you read as low as 2 millivolts.

## 79 THREE-BAND SHORTWAVE CONVERTER

Pull in the hottest shortwave bands—49-, 41- and 31-meters—plus U.S. time station WWV with this all-FET, tunable converter.

## 98 455-kHz BEAT- FREQUENCY OSCILLATOR

Crystal-controlled, count-down circuit helps you tune to the carrier with accuracy, providing CCB listeners with a new tool.

## 93 CPP1 CODE-PRACTICE PROCESSOR

Now you can learn the differences between the dahs and dits, and pick up the required code speed to get your Amateur Radio ticket from a single-chip processor.

## CONTENTS/INDEX

### ● TEST EQUIPMENT PROJECTS

- 9 Digital Prototyping System—for bench-top Experimenters
- 32 Ribbon Cable Tester
- 42 Single Sweeper One—step-up your oscilloscope
- 48 Super Sensitive Simple Voltmeter
- 51 Mini Audio Generator for all sound systems
- 75 Meg-O-Dapter—checks out insulation resistance
- 83 Scope Calibrator

### ● PROJECTS FOR THE FUN OF IT

- 20 Soundbox-80-add sound to TRS-80 games
- 24 Custom Sound for Your Car
- 61 Syn-dle-the Electronic Candle
- 69 Electronic Slot Machine
- 98 455-kHz Beat Frequency Oscillator

### ● COMPUTER PROJECTS

- 28 Make Your Own Computer Cables
- 54 Retrofitting the Sinclair/Timex Computer for a standard video output
- 93 CPP1 Code Practice Processor—for new and stepping-up Hams

### ● PROJECTS YOU CAN'T PASS UP

- 34 MoCo (Moving Coil) Preamplifier—for audio Buffs
- 58 Electronic Flasher for Your Car
- 65 JBL System for Musicians—you build the enclosure
- 79 Three-Band Shortwave Converter
- 87 Pro Cabinets for Home-Brew Projects
- 92 Extra-Low-Power Pilot Light

### ● DEPARTMENTS

- 1 Editorial—news on how to Subscribe
- 4 New Products
- 5 Coverage Cover
- 8 Advertising Index
- 8 Letters from our Readers
- 101 Postage-Paid Free Information Cards

# NEW PRODUCTS

**ADAPTER**, is an RS232 interface adapter for the Zenith model Z71 personal-information terminal. The Z71 terminal contains an integral 300-baud modem for communicating with computers over telephone lines. This new interface allows it to function also as an RS232 terminal to communicate with com-

puters at the user's site.

The interface plugs in between the Z71 keyboard and power supply, supporting all data rates available from the Z71 (110 through 2400 baud). The retail price of the RS232 adapter is \$69.00. — **Magnolia Microsystems, Inc.**, 2264 15th Ave., West, Seattle, WA 98119.



CIRCLE 818 ON FREE INFORMATION CARD

**RADAR WARNING**, The Bearfinder *Quest*, provides a four-step relative *distance* information display, using LED signal-strength indicators. The first indicator and accompanying slow audible beep announces the acquisition of the radar signal. The second, third, and fourth indicators each illuminate when a motor vehicle has traversed one-half the remaining distance to the radar source. As each indicator illuminates, the audible beep becomes faster and faster. When the last indicator illuminates, the sound is steady, warning that the radar source is near.

The Bearfinder *Quest* receives both X- and K-band signals from all types of radar, including moving and hand-held pulse types. It is designed for installation on the sunvisor or on the dash of a motor vehicle. The small, compact case is just 5-inches wide, 1¾-inches high, and 4-inches deep, is made of extruded aluminum, and weighs approximately one pound. It is available only from the factory,

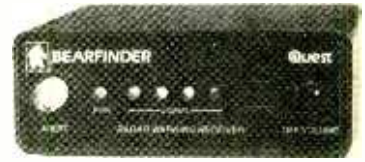

CIRCLE 820 ON FREE INFORMATION CARD

and comes with plastic carrying case, velcro square for attachment to the dash, visor clip, instructions, and a one-year warranty. The price is \$239.00. — **Bearfinder Co., Inc.**, 324 North Dixie Drive, Vandalia, OH 45377.

**POWER SUPPLIES**, the *QPS Series*, are in a low-profile design featuring two flush mounting surfaces for easy installation in OEM applications.

*QPS* models have an input of 115-volts AC ± 10%, 47-400Hz. Voltage/current ratings are 5 to 24 volts, at 3 amperes. Some features of the *QPS* series include infinite resolution adjustments, adjustable foldback current



CIRCLE 819 ON FREE INFORMATION CARD

limit, no overshoots on turn on/turn off or power failure, and lowest output deratings with temperature. Computer-grade components are used exclusively. Transformers use the UL-recognized Class B insulation system.

All models in the series are UL478-recognized and are 100% tested before shipment. All carry a 3-year transferable warranty, and each of the single-output linear power supply units is priced at \$19.95. — **Deltron, Inc.**, PO Box 1369 Wissahickon Ave., North Wales, PA 19454.

**STEREO PROCESSOR**, model 6140, takes audio sub-carrier signals from a satellite receiver and decodes them for use with an ordinary home-stereo receiver system. It will also allow monaural audio sub-carriers to be heard through hi-fi speakers for added enjoyment of satellite video programming.

Decoding of separate, multiplex, or matrix stereo is accomplished via front-panel push-button selectors. Two independent tuning

## Radio-Electronics REPRINT BOOKSTORE

- |   |   |
|---|---|
| <input type="checkbox"/> Build Your Own Satellite TV Receiver..... \$7.00   | <input type="checkbox"/> Radio-Electronics back issues (1981)..... \$3.50<br>(March, December 1981 not available)<br>Write in issues desired..... |
| <input type="checkbox"/> 8-Ball Satellite TV Antenna..... \$5.00  |   |
| <input type="checkbox"/> Build Your Own Robot..... \$12.00  |   |
| <input type="checkbox"/> TV Descrambler (January, February 1981)..... \$3.00  |   |
| <input type="checkbox"/> Video Entertainment (January 1982)..... \$2.00   | <input type="checkbox"/> Special Projects (Winter 1980)..... \$4.00   |
| <input type="checkbox"/> Your Own Computer (October 1981)..... \$3.00   | <input type="checkbox"/> Special Projects (Spring 1981)..... \$4.00   |
| <input type="checkbox"/> Radio-Electronics back issues (1983)..... \$3.00<br>(January, February 1983 not available)<br>Write in issues desired..... | <input type="checkbox"/> Special Projects #4 (Summer 1982)..... \$4.00  |
| <input type="checkbox"/> Radio-Electronics back issues (1982)..... \$3.00<br>(January 1982 not available)<br>Write in issues desired.....           | <input type="checkbox"/> Special Projects #5 (Winter 1983)..... \$3.00  |
|   | <input type="checkbox"/> Special Projects #6 (Spring 1983)..... \$3.00  |
|   | <input type="checkbox"/> Radio-Electronics Annual 1983..... \$2.50  |
|   | <input type="checkbox"/> How to Make PC Boards..... \$2.00  |
|   | <input type="checkbox"/> All About Kits..... \$2.00   |
|   | <input type="checkbox"/> Modern Electrics (Vol. 1, #1..... \$2.25<br>April 1908)  |
|   | <input type="checkbox"/> Wireless & Electrical Cyclopedica..... \$4.95<br>(1918) (176 pp)   |

To order any of the items indicated above, check off the ones you want. Complete the order form below, include your payment, check or money order (DO NOT SEND CASH), and mail to Radio-Electronics, Reprint Department, 200 Park Ave South, New York, NY 10003. Please allow 4-6 weeks for delivery.

If you need a copy of an article that is in an issue we indicate is unavailable you can order it directly from us. We charge 50¢ per page. Indicate the issue (month & year), pages and article desired. Include payment in full, plus shipping and handling charge.

ARTICLE \_\_\_\_\_

MONTH \_\_\_\_\_ YEAR \_\_\_\_\_

PAGES \_\_\_\_\_

TOTAL PAGES \_\_\_\_\_ @ 50¢ each \_\_\_\_\_ TOTAL PRICE \_\_\_\_\_

MAIL TO: **Radio-Electronics** SP-7  
Reprint Department, 200 Park Ave. South, New York, NY 10003

All payments must be in U.S. funds

Total price of order..... \$ \_\_\_\_\_

Sales Tax (New York State Residents only)..... \$ \_\_\_\_\_

Shipping & Handling (U.S. & Canada only) (Includes FIRST CLASS POSTAGE) \$1.00 per item..... \$ \_\_\_\_\_

All other (\$2.00 per item, sea mail)..... \$ \_\_\_\_\_

(\$4.00 per item, air mail)..... \$ \_\_\_\_\_

Total Enclosed..... \$ \_\_\_\_\_

Name..... \_\_\_\_\_

Address..... \_\_\_\_\_

City..... State..... Zip.....

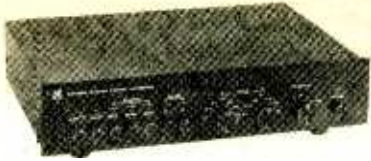

**CIRCLE 821 ON FREE INFORMATION CARD**

controls are provided for selecting the sub-carrier channel desired in the range of 5.5MHz to 8.0MHz. A selectable IF filter allows reception of high-fidelity programming, with low distortion.

For tuning favorite stations easily, four independently pre-set positions may be selected using the PROGRAM switch. Popular sub-carrier frequencies have been pre-programmed at the factory on all four of those positions. The TUNE position on the switch allows the user to select alternate sub-carriers.

The model 6140 has a suggested retail price of \$359.00. — **Channel Master**, Division of Avnet, Inc., Ellenville, NY 12428.

**VIDEO SWITCH**, model VS-6004, provides an inexpensive way to control all TV or Video-signal sources connected to a TV set from one convenient location. By simply flipping a switch, up to four signal sources may be attached to a TV set and two to a VCR. Viewers will have easy access to off-the-air or

cable programs, video-games, VCR's, Videodiscs, satellite receivers, or home computers at their fingertips.

The model VS-6004 also allows the viewer to monitor and edit programs being recorded on a VCR or copied from one VCR to another. High-isolation switching circuits reduce in-



**CIRCLE 822 ON FREE INFORMATION CARD**

teraction between signal sources, and prevent interference. The completely passive device requires no AC power to operate, and is compact and lightweight. Bandpass is Channels 2 through 83; all connections are 75-ohm type.

The model VS-6004 is priced at \$41.75. — **Winegard Company**, 3000 Kirkwood Street, PO Box 1007, Burlington IA 52601.

**COMPUTER POLLUTION CONTROL**, The *Magnum Isolator*, is designed to control severe electrical pollution. Electrical pollution

drives microcomputers bananas, and many systems even create their own pollution. Disks and printers often create enough electrical interference to disrupt an entire program; nearby electronics equipment can be affected as well.



**CIRCLE 823 ON FREE INFORMATION CARD**

The *Magnum Isolator* incorporates heavy-duty spike/surge suppression and features four individually quad-Pi filtered AC sockets. It will control pollution for an 1875-watt load; each socket can handle a 1000-watt load.

The *Magnum Isolator* is priced at \$200.95. — **Electronic Specialists, Inc.**, 171 So. Main St., PO Box 389, Natick, MA 01760. (More on page 6)

## COVER COVERAGE

Probably the most exciting phase of preparing a magazine for publication is the generation of a suitable cover picture to tell our newsstand magazine readers what we have to offer them in the issue. And that is exactly what we have done on our cover. However, we did use a few props to dress up the photographic scene, and I'd like to tell you about them.

Our publisher, Larry Steckler, came upon an unusual tool cabinet (Item A) marketed by Concept 2001, Inc. that gave him visions of a tidy workbench at home where the tools he used most often would always be in reach. He dug into his pocket and made the purchase on the spot—that's impulse buying. When I saw the tool cabinet, I experienced impulse larceny! However, the best I could do was borrow the unit for the

cover shot of this issue of **Special Projects**. The photo reveals that decorative, washable, plastic tool cabinet with an assortment of brackets and clips holding all sorts of tools—many of which you'll recognize. Should you care to obtain more information on the Concept 2001 cabinets and accessories, circle number 872 on the Postage-Paid Free Information Card bound in the back of this issue.

OK Industries, Inc. was kind enough to loan to us their model SA-3 Temperature Controlled Soldering System (Item G). It looks like something that NASA designed, and works as well as their space shuttles, so I decided to use it on this issue's cover. A fingertip control on the SA-3 permits accurate and useful temperature regulation of the soldering tip whereby the experimenter has the required heat necessary to solder IC's onto boards and remove #14 solid copper wire from chassis ground lugs. Now, the need for more than one soldering iron on the bench, or the dangerous replacement of hot screw-in soldering tips, has been eliminated. What I like best about the SA-3 is the feature of reducing the heat on the tip to a low value when the soldering sequence is interrupted, and then setting the temperature to the desired level for getting back to work quickly. The SA-3 makes sense and OK makes it. Want more information? Then circle Number 873 on the Postage-Paid Free Information Card and mail it today.

The other equally attractive items on the cover are projects made by our authors.

What is more important: We give you the complete construction details so that you can make your own! Here's the lowdown on each:

*Syndle*—a battery-operated electronic candle (Item C) that looks like the real thing, it flickers and dims at a random rate. It is the kind of mood-setter you would add to any room in your home to create an atmosphere. That is the *Editor's Choice* for this issue.

*Digital Prototyping System*—a clever packaging of two probes, clock outputs, and power supply (Item B) for the test-bench designer.

*Single Sweeper One*—an advanced project (Item F) for the digital experimenter and serviceman who still is using yesterday's oscilloscope that does not feature a single-sweep blanking circuit.

*455-kHz BFO*—a mini-project (Item D) that you've talked about but never really undertook to assemble. Now you have no excuse—we give you the complete plans.

*Mini Audio Generator*—At last, a pocket-size device (Item E) for troubleshooting audio systems, providing frequencies throughout and beyond the listener's frequency range with output-level control.

That covers the projects found on the cover, but there's so much more in this issue that I'm sure you'll be involved with project building until we publish our Fall 1983 issue of **Special Projects**. Till then, happy building! —**Julian S. Martin**

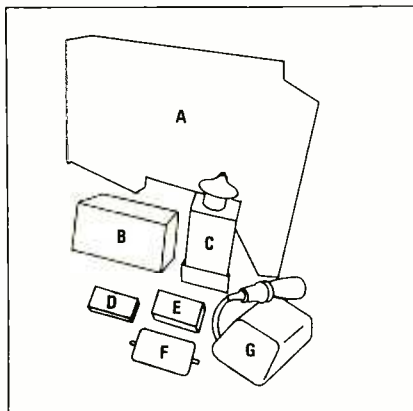

# NEW PRODUCTS

**PRINTER**, model *DMP-100*, is a dot-matrix printer with graphics capability. It prints 50 characters per second at 10 characters per inch, and has a bit-image mode to allow printing of fully-addressable, high-density graphics. Using an optional screen print program, the model *DMP-100* can produce detailed black-and-white graphics printouts similar to those on the *TRS-80 Color Computer* screen display.

The model *DMP-100* has 80 upper and lower case 5 × 7 dot-matrix characters which

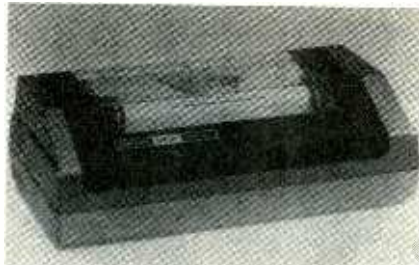

CIRCLE 824 ON FREE INFORMATION CARD

can be printed on an 8-inch line, with underline capability. The user can select 10 characters per inch (80 columns at 27 lines per minute) or expanded at 5 characters per inch (40 columns). The printer measures 5 $\frac{5}{16}$  × 16 × 8 $\frac{1}{4}$  inches and weighs 8 $\frac{3}{8}$  pounds. It operates from 120-volts AC at 60 Hz, uses 15 watts, and is U.L. listed. A ribbon cartridge is included.

The model *DMP-100* is priced at \$399.00.—**Tandy Corporation/Radio Shack**, 1800 One Tandy Lane, Fort Worth, TX 76102.

## Radio-Electronics

SPECIAL REPRINT  
BUILD A BACKYARD SATELLITE TV RECEIVER



Sixth Printing: Sold Out!  
Seventh Printing—Just Off Press!  
Reprints Now Available!

### Don't miss out again!

Send away today for your 36-page booklet containing a complete reprint of all seven articles in the series on Backyard Satellite TV Receivers by Robert B. Cooper Jr.

This all-inclusive report gives you all the data you need to build your own Backyard Satellite TV Receiver.

- TELLS ALL ABOUT domestic satellite communications, with full details on how you can pull those elusive TV signals from space.
- LEGAL REQUIREMENTS, technical specifications, and how you, the

home constructor, can meet them. Find out what mechanical and electronics skills you need.

■ RECEIVER CHARACTERISTICS, technical details and specifications, along with examples of actual receivers built at comparatively low cost.

■ ANTENNA DESIGN... and exactly how you can build a spherical antenna, while keeping total earth-station cost for the complete system under \$1,000.

■ THE FRONT END is critical when you build your own system. We help you explore several different ap-

proaches to making one that will work for you.

■ RECEIVER-SYSTEM hardware, and how it goes together to bring you direct-from-satellite TV reception in your own home.

To order your copy:

Complete coupon and enclose it with your check or money order for \$7.00, plus \$1.00 for postage and handling. We will ship your reprint within 6 weeks of receipt of your order. All others add \$4.00 for postage. New York State residents must add 5% sales tax.

**MICROCOMPUTER**, the *Vector-4*, incorporates both 8-bit and 16-bit microprocessors and presents a choice of several operating systems. It calls on 16-bit commands to speed up selected 8-bit operations. To provide maximum program-development flexibility, multiple operating systems are available for the *Vector-4*, including CP/M, MS-DOS, and OASIS.

The *Vector-4* includes a detached keyboard, conveniently located integral floppy-disk drives, and a green-phosphor video-display screen that is treated optically to eliminate reflection and glare.

With a single-board microcomputer design for compactness and reliability, the *Vector-4* comes standard with 128K of internal RAM, expandable to 256K. Memory-mapping logic allows the Z-80 to access the entire main memory in 64K increments. There are also three S-100 card slots for accommodating



CIRCLE 825 ON FREE INFORMATION CARD

communications interfaces, peripheral controllers, or other specialized input/output boards. The graphics capability is based on a single-IC CRT display controller and time-sharing of main memory between the CPU and the video-display controller. That provides faster access to screen memory, by permitting it to be anywhere in the 128K main memory. High-resolution graphics is provided via a 640 × 312 pixels display.

Two versions of the *Vector-4* are available: the 4/20, with two 5 $\frac{1}{4}$ -inch, 630K floppy-disk drives priced at \$4495, and the 4/30, with a single 630K floppy and a 5 $\frac{1}{4}$ -inch, 5 megabyte Winchester drive, priced at \$5995. Both versions use Vector's proprietary Dual mode disk controller, which has automatic error detection and correction circuits.—**Vector Graphic, Inc.**, 500 N. Ventu Park Road, Thousand Oaks, CA 91320. SP

**Radio-Electronics**

Satellite TV Reprints  
45 East 17th Street  
New York, N.Y. 10003

Please print

EP-7

I want \_\_\_\_\_ reprints @ \$7.00 each, plus \$1. Handling & Postage.  
I have enclosed \$ \_\_\_\_\_ . N.Y. State residents must add sales tax.

(Name)

(Street address)

(City)

(State)

(Zip)



**Radio Electronics** #7  
\$2.25 SUMMER 1982 48784

**special Projects**

**SYNDLE**  
The Electronic Candle that flickers like a Wax Taper

MAKING PRO CABINETS for Home-Brew Projects

**Build it for JUN**

3-Band Shortwave Converter  
Electronic Slot Machine  
Pre-amplifier for moving coil Phono Cartridge  
Soundbox-80 for Computer Game Sounds  
Prototyping Power Supply

**Test Gear Projects**

Ribbon-Cable Tester  
Meg-O-Dapter for DVM  
Mini-Audio Generator  
Scope Calibrator  
Single Sweeper One Blanker

**PLUS....**  
JBL Sound System for the musician!

**INTRODUCING**  
**OUR NEW**  
**SUBSCRIPTION**  
**OFFER!**

**Become a**  
**Charter Member**  
**Subscriber!**

**Get every issue!**

**SUBSCRIBE**  
**TODAY!**

**Use the order**  
**form below.**

## Subscribe Today!

■ IF YOU'RE THE KIND OF READER that doesn't want to wait, you can order your next copy of **Special Projects** now. **Special Projects** is crammed full of electronic projects that you won't be able to wait to build for yourself. You can expect top-notch digital projects, fun-to-play electronic games, valuable add-on computer projects, BCB and shortwave receivers, photographic/darkroom gadgets, devices to improve your car's performance, test equipment ideas, and more in every jam-packed issue of **Special Projects**.

■ TO HELP YOU TO BE SURE that you don't miss any future issues of **Special Projects**—SUBSCRIPTIONS ARE NOW AVAILABLE!

■ YOU CAN HAVE THE NEXT FOUR ISSUES of **Special Projects** delivered directly to your home for only \$9.00. We pay the postage. If you want the next eight issues, you can even save a dollar off the newsstand price. Get eight issues for \$17.00.

■ EVERY ISSUE OF SPECIAL PROJECTS will continue to contain a variety of construction articles to suit every taste. In addition, feature articles on electronics fundamentals, test equipment and tools will round out each issue. Of course, we will continue to provide new product and literature listings to keep you up to date on the latest developments in electronic technology.

■ GET IN ON THE ACTION! Order your next issue of **Special Projects** today. Use the convenient order coupon below.

<p><b>Special Projects</b> <b>SUBSCRIPTION</b></p> <p><input type="checkbox"/> I want to be sure I don't miss any issues. Send me the next four issues of <b>Special Projects</b> for \$9.00: starting with #8. Postage is free in U.S. For Canada add \$3.00. Foreign add \$7.00.</p> <p><input type="checkbox"/> I want to be sure I don't miss any issues and want to save \$1.00 too. Send me the next eight issues of <b>Special Projects</b> for \$17.00: Starting with #8. Postage is free in U.S. For Canada add \$6.00. Foreign add \$14.00.</p> <p><input type="checkbox"/> Send me _____ copies of <b>Special Projects</b> #8 at \$2.25 plus \$1.00 postage and handling for US, Canada and Mexico. U.S. funds only. All other countries add \$2.00.</p>	<p>Detach and mail today to: SPECIAL PROJECTS SUBSCRIPTION DEPT. 200 PARK AVE. SOUTH NEW YORK, N.Y. 10003</p> <p>CASH WITH ORDER ONLY <span style="float: right;">SP-7</span> Allow 6-8 weeks for the first issue to arrive.</p>
<p>Please print</p> <p>(Name) _____</p> <p>(Street Address) _____</p> <p>(City) _____ (State) _____ (Zip) _____</p> <p style="text-align: right;">DSP</p>	

# LETTERS

## RAVE REVIEW

I love your plans on building the 10-step, 0.1% voltage calibrator ("Voltage Calibrator", **Special Projects #6**, page 42) that I have breadboarded from the plans you published. I found the unit to be rock stable when I tried it out on my 6-digit Fluke DVM. According to the article, the kit was to be offered and I would have ordered the kit as opposed to the fuss and bother of picking up the parts and breadboarding it from scratch. Where and how can I get kits so I can make a few more voltage calibrators?

HARMON HADDIK  
Toms River, NJ

*Well, Sol, we're sorry about leaving out the pricing and kit information from the article. However, you can order the kit from Electronic Technical Consultants, P.O. Box 29278, Denver, CO 80229 for only \$40.00 with standard reference diode and \$60.00 with Analog Devices' super stable and spec'ed reference diode. Be sure to include \$4.50 for postage and handling. By the way, when the author checked the article, he missed a connection that was omitted from the diagram. Terminal 13, (clock enable) should be tied to ground.*

*We'd like to thank the builders of that project who wrote and told us of their experiences with it. Your letters encourage us to prepare more stories like the voltage-calibrator for publication.*

## FEELS SAFER

Your "Fire-Alarm Module" project (**Special Projects #6**, page 23) is a dinky little project that's worth its weight in CMOS chips after you build it. Everyone in my family feels safer now that the fire-alarm module is installed in my home. Of course I had to modify the project, as I always like to do. I have two 6-inch alarm bells sound off instead of the buzzer that you specified. Also, I tied in two floormat switches to the circuit as an addition to the intrusion-alarm system already installed by professionals. Thanks for a great project!

PAT DEARBORN  
Salt Lake City, UT

*I'm glad you called it a "dinky little circuit" because that is what it is, should you not have the imagination to adapt it to the needs of your home and office. One reader wrote to us telling how his office complex uses 12 separate circuits as an annunciator to alert executives to call the operator at the front desk for an important message. The signal LED's are placed at strategic parts of the office-complex corridors, so that executives*

*can spot at a glance when their particular LED indicator is lit. The bell/buzzer circuit is not used because silence is "golden" in that office setting.*

## BUDGET TEST GEAR

I enjoy making test equipment from project plans in magazines and books. I'm sure that there are many more like me, so that the editors of **Special Projects** should consider coming up with an entire issue on test-equipment projects.

BOB ANDERSON  
Commack, NY

*Bob, not everyone is a test-equipment project builder. True, from time to time most experimenters will build a test-equipment project; but we cannot ignore all the hobbyists by devoting an entire issue to just one specialized aspect. Nevertheless, in this issue of **Special Projects** we have devoted a considerable portion of our editorial space to test-equipment projects. Hope you find this issue to your liking.*

## TIME CUTTER

You have no idea how much time your story "Tracer Tone" (**Special Projects #5**, page 36) saved me when I ran into a short-circuit problem in my firm's computer cable hook-up. I had built the Tracer Tone a few months earlier on a lark. It was a simple circuit, required a few parts, most of which were within reach of my workbench, and it worked like a charm. I put the gadget aside, considering it to be a novelty until that God-awful short in the ribbon-cable rat nest in the false ceiling. Today I placed the plans for Tracer Tone up on the bulletin board for all to see, and I noticed a few technicians collecting parts to make their own. That's OK with me as long as they don't take my back copies of **Special Projects**.

PREFER TO BE NAMELESS  
Silicon Valley, CA

*Thanks for the letter, Nameless. Now, dig your toenails into the carpet, because when you turn to page 32 in this issue you may just leap into the overhead with excitement. We have an equally simple circuit that tests ribbon cables for shorts and opens. This one is a winner, and if your plant is creeping with ribbon cables (as our office is) this project is for you. Let me know what you think of it.*

## COMPUTER BUFF UNSATISFIED

Come on you guys, get with it. The way to go is computers! There is so little in each issue of **Special Projects** on the

greatest thing since sex—computers—and the editors are doing next to nothing about it. You guys are in the dark ages. When is the editorial policy going to change?

ROD LESTER  
Northbrook, IL

*My wife tells me that she is giving up her subscription to her favorite knitting magazine because the editorial is almost 100% computer theory and software discussions. Well, maybe I'm making that up, but it seems to be the case nowadays. It appears as if every electronics magazine is changing its name to some computer-type title to pull in the big bucks they can earn in the computer field; in so doing, they forget about their faithful and loyal readers. Well, faithful and loyal readers who are electronics experimenters, stick with **Special Projects**, because we are sticking with you! Yes, we will have some computer projects in every issue, but the bulk of the issue will cover the varied interests of all our readers. Electronics experimenters don't change their spots (solder burns) just because a new fad is in the scene. Remember how everyone ran to CB radio? Try to find someone who will admit to owning a CB rig today? No, we don't follow fads—we serve electronics experimenters!*

## TELL ME WHY

Our teacher wants us to pass the FCC Radio Operator's second-class license examination in order to get a passing grade for the term. I don't plan to use the license, yet I'm forced to take it. Is there a better way?

CHARLES NETTLE  
New York City

*There is a better way, and that is to take the exam, prove to your instructor that you can pass the test, and hang on to the license, because, later, that may very well make the difference between your getting a job or not. Prove to yourself that you can motivate and drive yourself to higher goals.* SP

## ADVERTISING INDEX

**SPECIAL PROJECTS** does not assume any responsibility for errors that may appear in the index below.

Free Information Number	Page
801	A P Products Incorporated..... Cover 2
--	Cleveland Institute of Electronics, CIE..... 19
--	Electronics Technology Today Inc.. 100
--	NRI Schools..... 37
802	OK Industries, Inc..... Cover 4
--	Windjammer Barefoot Cruises, Ltd..... Cover 3

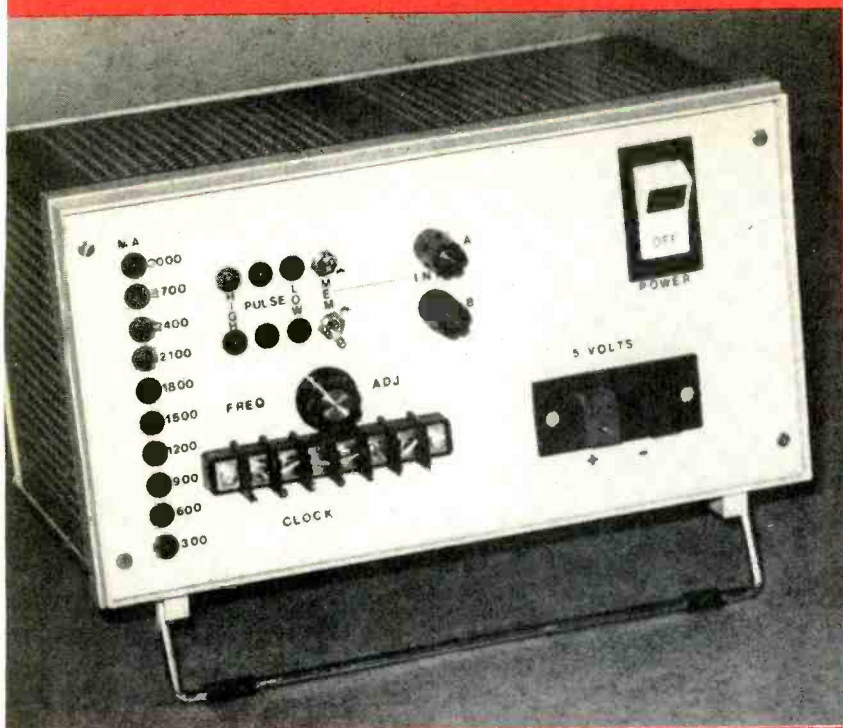

# Digital PROTOTYPING System

REMEMBER THE LAST CIRCUIT THAT YOU BUILT ON A SOLDER-less breadboard? The wires were running off the block everywhere, and were connected to a makeshift power supply. A quick twist of the wires, insulated by precisely angled bends, is all that was needed so that the bare conductors never touched, but somehow did! Once the power supply is deemed reliable, it is a simple matter of juggling a logic probe around in a manner as to be most effective for debugging. All the while keep in mind that power cord movement must be kept to a minimum, thus preventing excessive testing and repairing of the power supply.

The Digital Prototyping System described here provides a 5-VDC, 3-ampere regulated power supply, with an LED current monitor. Two digital logic probes with memory are

added to prevent wire-lead clutter and to make it hard to misplace the probes. Each probe can detect pulses as short as 40 nanosec. An adjustable clock with several divided-down outputs is included to help streamline breadboarding time and to eliminate wasted space on the block.

## The power-supply circuit

The power-supply circuit is shown in Fig. 1. Transformer T1, bridge-rectifier BR1, and filter-capacitor C6 form a full-wave power supply regulated by IC7, a 78H05 high-current regulator integrated chip, and capacitor C7. The output is rated at 5-volts DC into a 3-ampere load maximum. The current monitor uses a .5-ohm, 20-watt resistor, R26, to cause a voltage drop equal to .5 millivolt per milliamp of

ALAN BRADFORD

***The next time you undertake to design your own digital project, let this unique device provide you with regulated +5-VDC power, with LED current monitor, two logic probes, and 12 clock frequencies from .01 to 170K Hz***

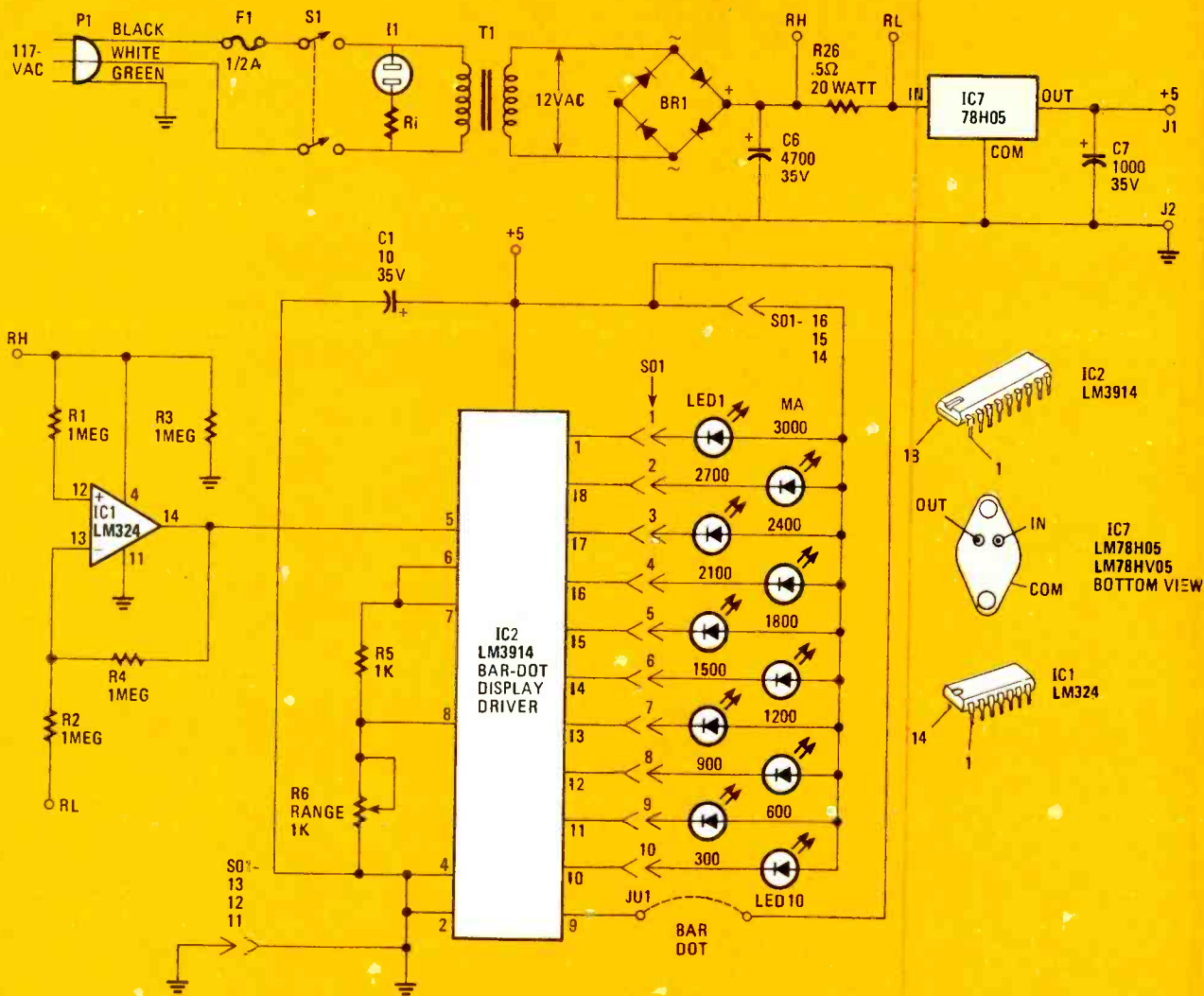

FIG. 1. THE POWER-SUPPLY PORTION of the Digital Prototyping System uses a simple bridge rectifier to supply power to the 5-volt DC regulator chip, IC7. Resistor R26 senses the current used at the output and displays that minuscule voltage drop across the bar-dot display driver, IC2. With jumper JU1 installed, a bar display will indicate current in 300 mA steps very much like a rising thermometer.

output current. Two 1-ohm, 10-watt resistors were used in parallel to form R26. The internal current used by the 78H05 regulator, IC7, is small enough to be ignored. That proportional voltage across terminal points  $R_H$  and  $R_L$  is fed into IC1, a LM324 unity-gain op amp, that ground-references the signal so that any voltage drop on the unregulated side of the power supply will not affect the current reading. IC2 is a LM3914 bar-dot display driver. The input divider is calibrated to read 300 mA per LED by resistors R5 and R6. Pin 9 on IC2 selects either a bar or dot display. Connecting pin 9 to +5 volts DC will select the bar mode.

The regulator, IC7, can put out slightly more than 3 amperes for short lengths of time. Prolonged use above 3 amperes will cause early failure of the transformer or bridge rectifier unless they are rated well over 3 amperes. The regulator, IC7, is internally protected against short circuits that draw more than 5 amperes. Staying within those limits should insure long life of the power supply.

### Double logic

The two logic probes are identical and are shown in Fig. 2. Half of IC3 and IC4 make up each probe. The operation of only one probe will be described here. The other probe works

the same way, and is totally independent of the first. The numbers shown in parenthesis are symbol and pin designations for the second probe.

NPN transistors 2N3904, Q1 and Q3, along with two sections of hex inverter 74LS04, make up the state detector for the logic probe. Transistor Q3 turns on during low pulses causing IC4-b to go high and turning on the LOW LED indicator, LED13. When the input of Q3 is high or floating, the input of IC4-b is pulled high by resistor R13 and holding the LOW LED off.

The high-detection circuit is much the same. The input of IC4-a is held low through resistor R11 whenever the base of Q1 is low or floating. When a high is applied to the probe's input, Q1 turns on pulling up the input of IC4-a and turning on HIGH LED, LED11.

Short-pulse detection and memory are provided by IC3-a, a 74LS123 one-shot chip. IC3-a is triggered by a high to low transition of IC4-b or a low to high transition of IC4-a. The Q output remains low for a time determined by resistor R19 and capacitor C2, past the last trigger pulse. The pulse time is approximately 250 msec. with the values given for R19 and C2. Pulse memory is accomplished by closing PULSE switch, S2. The low pulse from the  $\bar{Q}$  is brought to the junction of C2

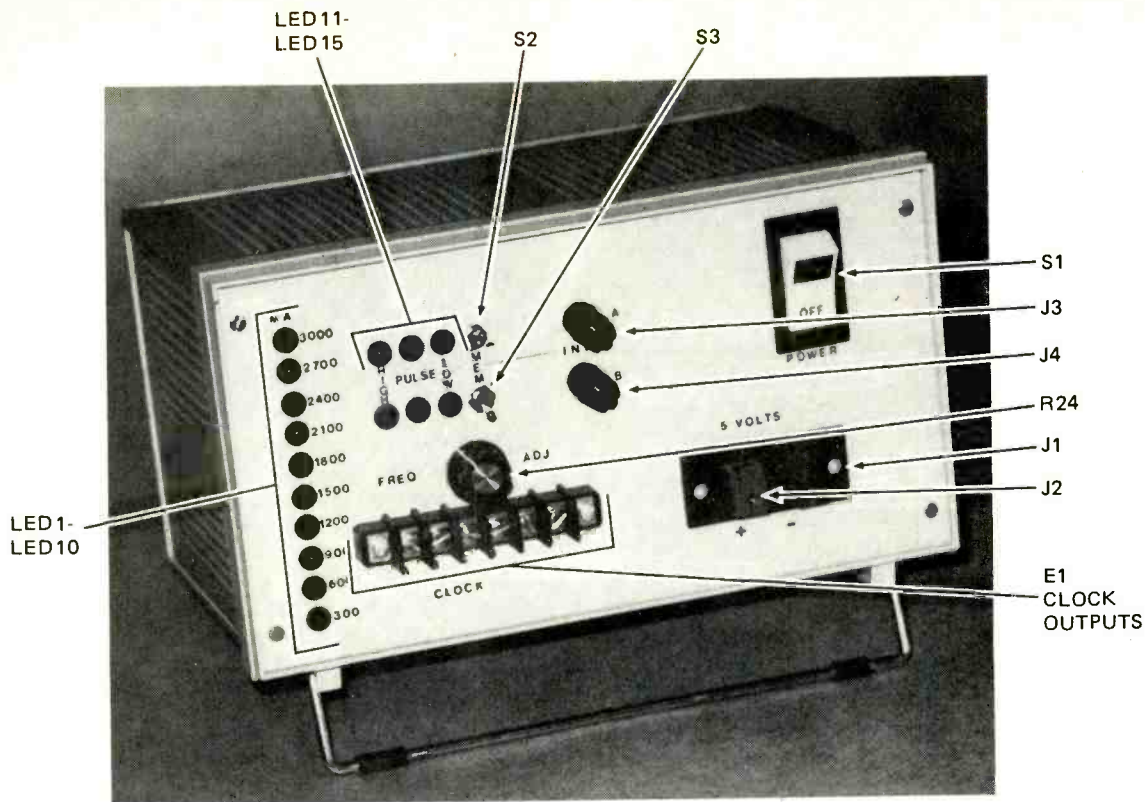

THE DIGITAL PROTOTYPING SYSTEM is as rich looking as its name sounds. Light-emitting diodes LED1 through LED10 indicate current supplied to an external-connected project in steps of 300 milliamperes. Clock outputs offer six frequencies from 170 kHz to 10 Hz at high setting of FREQ ADJ potentiometer R24 at maximum and 1560 to .01 Hz. (approximately 5.7 pulses per minute) at the minimum setting. Two independent and separate pulse-probe circuits are provided with suitable high- and low-state indicators with pulse memory. Of course, there's the 5-volt regulated power supply terminals and POWER ON/OFF switch S1—the brutish, but ever so essential, purpose of the Digital Prototyping System.

FIG. 2. THE LOGIC AND CLOCK PORTION of the Digital Prototyping System could be separate projects by themselves. The clock section offers six time-related clock signals for intervals listed in Table 1. The logic-probe section actually consists of two identical probes. The diagram lists symbol and pin designations for one logic probe, and another set of designations in parentheses for the second probe.

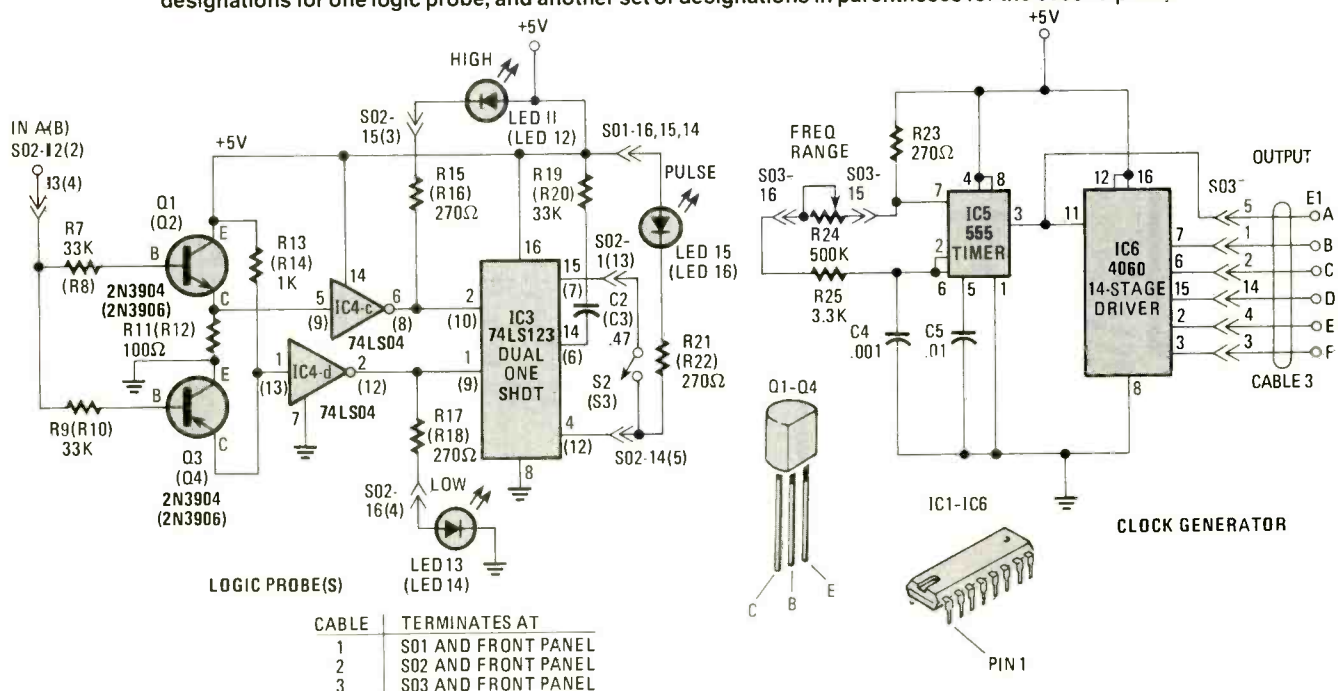

TABLE 1—CLOCK RANGES

Tap No.	High Frequency	Low Frequency
A	170 kHz.	1560 Hz.
B	11 kHz.	100 Hz.
C	1395 Hz.	12 Hz.
D	174 Hz.	1.5 Hz.
E	21 Hz.	.19 Hz.
F	10 Hz.	.01 Hz.*

\*5.7 pulses/min

and R19 preventing the capacitor from charging and holding the one-shot in its triggered state, with PULSE LED, LED15 on. Opening S2 causes C2 to charge and after 250 msec. Q goes high and the PULSE indicator, LED15 goes out.

### Tick tack

The clock circuit is made up of IC5 and IC6. See Fig. 2. IC5 is a 555 timer connected in its astable mode. The frequency is adjustable by range potentiometer R24. The output of the timer is fed to IC6, a 4060 CMOS 14-stage binary divider chip. The input signal is divided down and tapped off at five different stages. That allows the clock output to be available at six different frequencies simultaneously. The available range is from +170 kHz to less than .1 Hertz. The clock ranges are listed in Table 1.

### Construction

The main circuit can be assembled using an etched printed-circuit board, or a wire-wrapping technique on a perf-board. A foil pattern of the wiring side of the PC board is shown in Fig. 3. Component placement is shown in Fig. 4.

Mount all PC components to the board, making sure of

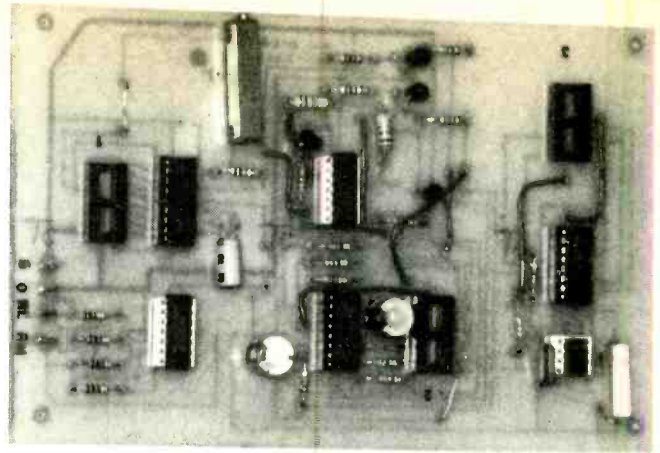

JUST SITTING THERE doing nothing makes the circuit board section of this project seem simple. Nevertheless, it would be wise to resort to a printed-circuit board for construction instead of using point-to-point wiring.

proper orientation of the IC sockets, and capacitors. Make sure that all wire jumpers are installed.

Due to the wide variety of component sizes available, the power supply is mounted on a terminal strip as shown in Fig. 5. Capacitor C6 is not a critical value; the bigger, the better. Any value from 3,000 to 10,000  $\mu\text{F}$  at 35 volts will do the job. If other than the specified transformer and bridge rectifier are used, make sure they can handle the current. If the value of C6 is above 5,000  $\mu\text{F}$  then the bridge should be rated at least 5 amperes. Otherwise, the high inrush of current during power-up could cause early failure of the rectifier.

The 78H05 regulator, IC7, must be mounted on a finned heat sink, as it will be dissipating around 25 watts at 3

FIG. 3. HERE IS THE ART for the foil side of the printed-circuit board. The use of the PC board is the only sure way to go.

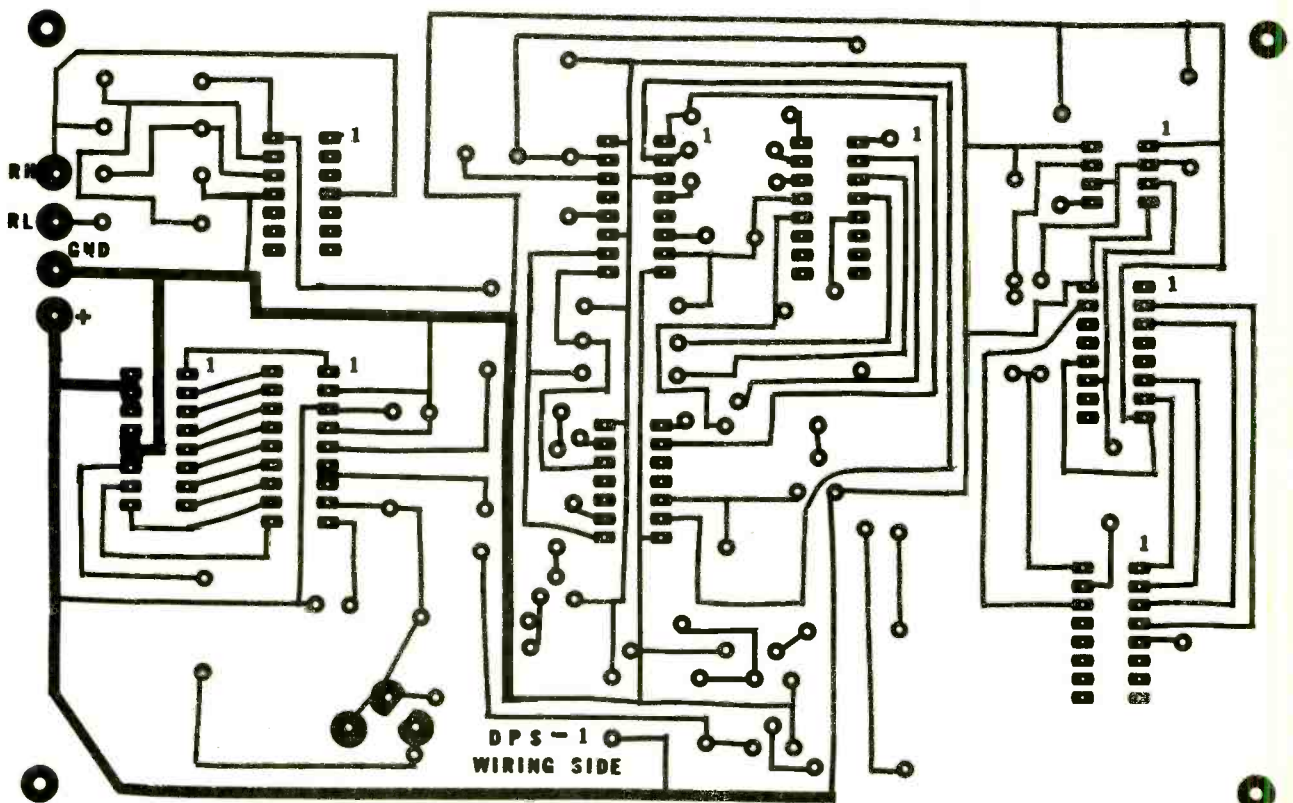

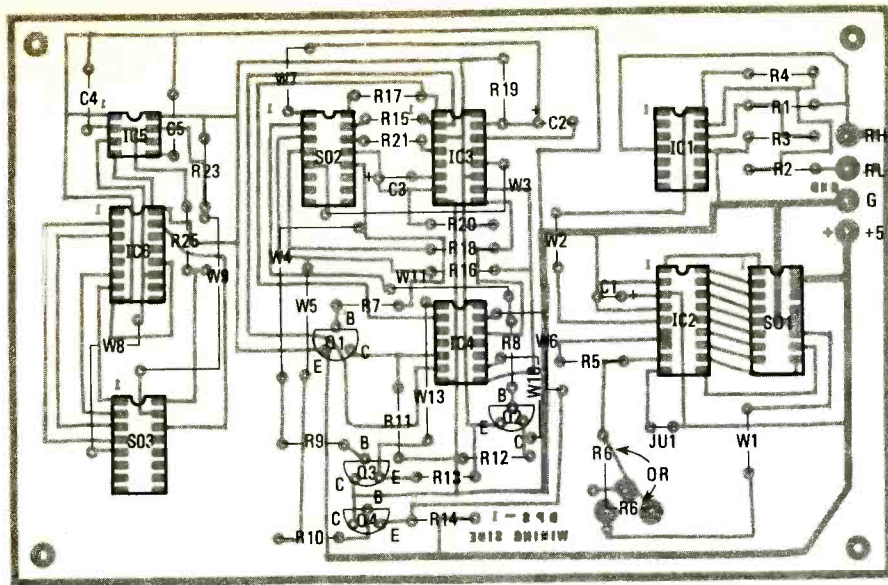

FIG. 4. PARTS LOCATED on the PC board are shown along with wire jumpers and the bar-dot jumper JU1. With JU1 connected, the light-emitting diodes will remain illuminated for a bar display. The foil pattern is shown in an x-ray view.

amperes output. Use heat-sink compound when mounting the regulator to the heat sink. If the heat sink is mounted inside the chassis, then adequate ventilation must be provided. The case of the regulator is ground so it is safe to mount it to the back of the chassis where the cooling will be the best.

Measure the four 1,000,000-ohm resistors, R1-R4 with an ohmmeter. Use the one with the highest value for R4 for best circuit operation. Measure the output of the op amp, IC1, with no load on the power supply. The offset should be less than 11 mV. Some experimentation with the value of R4 may be necessary. It must be higher than R1 to ensure a low enough offset.

A grounded three-wire electrical cord with molded plastic plug P1 is necessary to insure personal safety. The ground should be bonded, (good electrical contact) to the chassis with a nut, lock washer, and bolt. The transformer or terminal strip mounting bolt is a good place for the ground. The power-supply ground return should also be connected to the chassis at the same point.

All the front-panel parts are connected to the PC board by DIP jumper cables. The wires are soldered to the front panel parts and the PC-board ends plug into 16-pin IC sockets.

### Calibration and checkout

The only adjustment is for the current monitor. The voltage at pin 6, IC2 should be set equal to the voltage at pin 5 during full rated output (3 A). A simple calibration load is shown in Fig. 6. Connect a DC ammeter, capable of display-

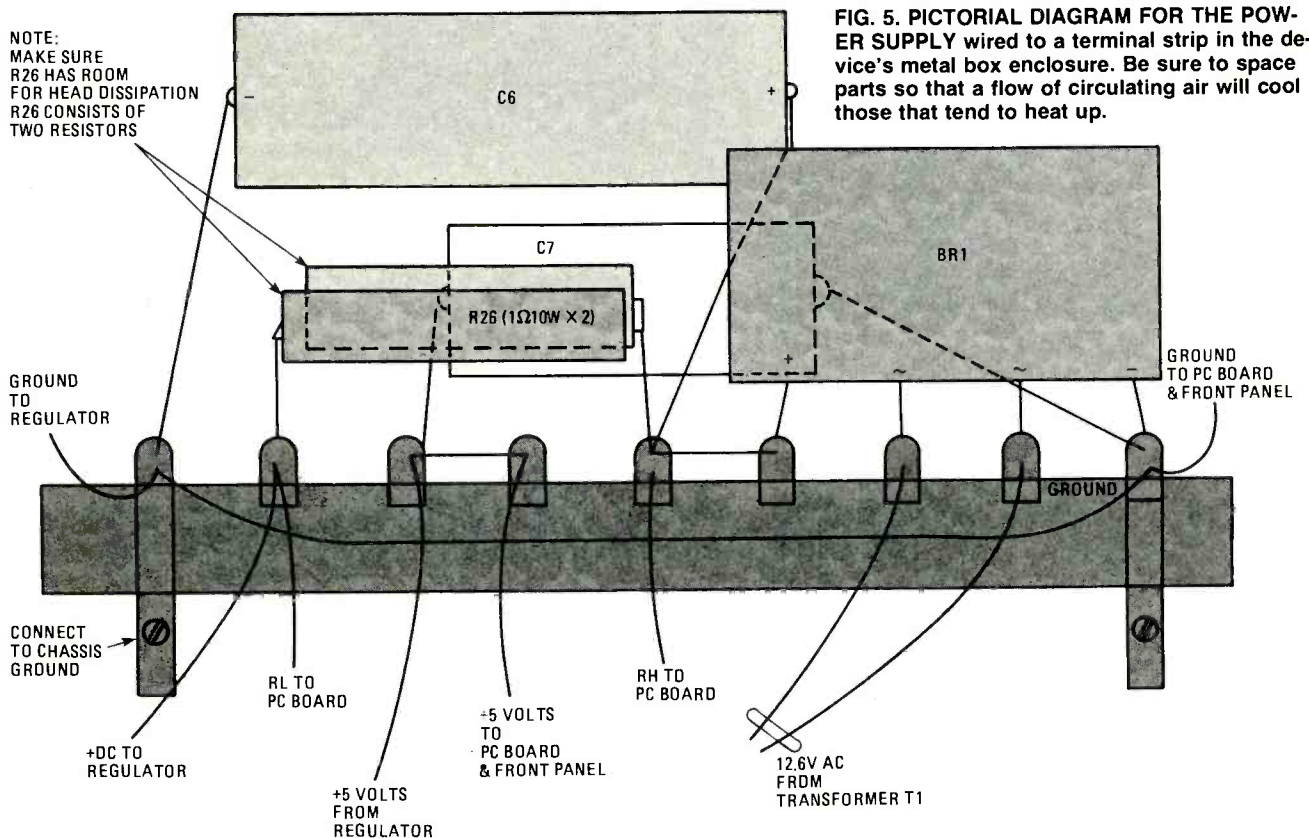
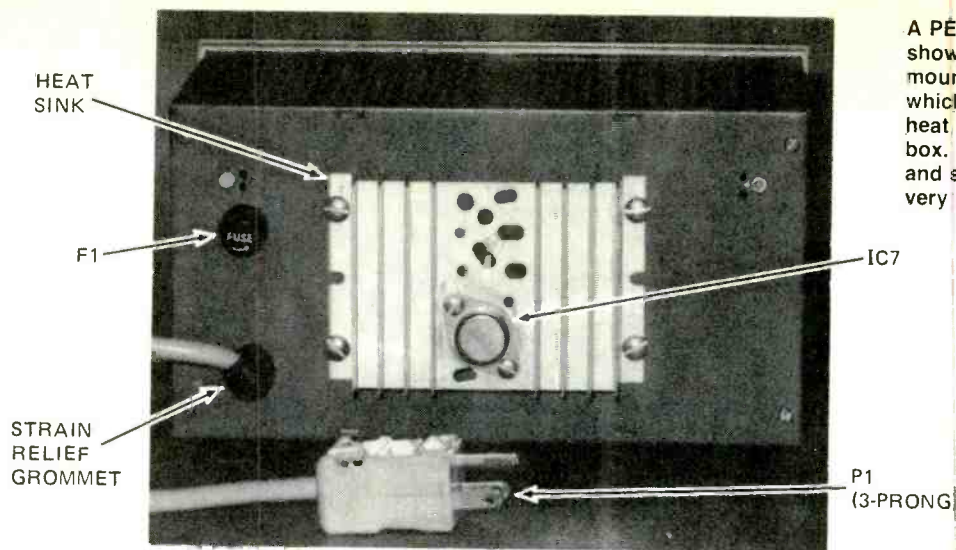

FIG. 5. PICTORIAL DIAGRAM FOR THE POWER SUPPLY wired to a terminal strip in the device's metal box enclosure. Be sure to space parts so that a flow of circulating air will cool those that tend to heat up.



A PEEK AT THE BACK of the unit shows the 5-volt regulator chip mounted on an over-sized heat sink which is OK considering that the heat sink was taken from the junk-box. Fuse location is satisfactory and strain relief on the power cord is very good construction practice.

ing 3 amperes, in series with the calibration load as shown. Adjust  $R_x$  until the meter reads 3 amperes. Using a DC voltmeter, measure the voltage at IC2, pin 5. Record the voltage and disconnect the load. Now move the voltmeter to pin 6 and adjust R6 until the voltage reading is the same as at pin 5. All voltage measurements are taken with reference to ground.

Be cautious around  $Q_c$  (Fig. 6) as it is dissipating 15 watts and will get very hot without a heat sink. Severe burns could result if the transistor is touched. If not using a heat sink, then disconnect the positive lead that goes to the power supply every 15 seconds to allow the transistor to cool to a safe

temperature.

The checkout of the logic probes is simple. With the power supply turned on, touch one probe to the +5 terminal. The HIGH LED (LED11) should go on and the PULSE LED (LED15) should stay on for only about 250 msec. Touching the probe to ground should light the LOW LED (LED13) and the PULSE LED should flash when the probe is removed from ground. With the memory switch, S2, on, touch the +5 bus and then ground the probe. The pulse LED should go on and stay on even after the probe is removed from the signal. When the switch is turned off the PULSE LED (LED15) should extinguish about 250 microseconds later. Both probes work

## PARTS LIST FOR DIGITAL PROTOTYPING SYSTEM

### SEMICONDUCTORS

IC1—LM324 operational amplifier (op-amp) integrated circuit  
 IC2—LM3914 bar-dot display driver integrated circuit  
 IC3—74LS123 dual one-shot integrated circuit  
 IC4—74LS04 hex inverter integrated circuit  
 IC5—LM555 timer integrated circuit  
 IC6—4060 CMOS 14-stage driver integrated circuit  
 IC7—78H05 5-volt DC regulator integrated circuit  
 BR1—6-A, 50-PIV bridge rectifier module (Radio Shack 273-1180 or equivalent)  
 LED1-LED16—Light emitting diode, red, 20 mA forward current  
 Q1, Q2—2N3904 NPN transistor  
 Q3, Q4—2N3906 PNP transistor

### RESISTORS

All resistors are 1/4-watt, 5% unless otherwise specified

R1-R4—1-Megohm  
 R5, R13, R14—1000-ohm  
 R6—1000-ohm trimmer potentiometer  
 R7, R8, R19, R20—33,000-ohm  
 R11, R12—100-ohm, 1/2-watt  
 R15-R18, R21-R23—270-ohm  
 R24—500,000-ohm potentiometer  
 R25—3,300-ohm  
 R26—0.5-ohm, 20-watt (use two 1-ohm, 10-watt resistors in parallel)

### CAPACITORS

C1—10- $\mu$ F, 35-WVDC electrolytic  
 C2, C3—.47- $\mu$ F disk  
 C4—.001- $\mu$ F disk  
 C5—.01- $\mu$ F disk

C6—4700- $\mu$ F, 35-WVDC electrolytic

C7—1000- $\mu$ F, 35-WVDC electrolytic

### ADDITIONAL PARTS AND MATERIALS

E1—6-terminal, barrier-type, screw-mount strip  
 F1—1/2-A fuse and holder  
 I1—Neon panel indicator light with built-in dropping resistor  
 J1, J2—Quick connect/disconnect, color-coded binding terminals (type used for rapid connect to speaker leads)  
 J3, J4—Multi-way binding posts, black  
 S1—DPST power switch  
 S2-S3—SPST miniature toggle switch  
 T1—Low-voltage power transformer; 117-VAC primary winding; 12.6-VAC, 3A secondary winding with no center tap  
 3-Cables, ribbon-type with 16 leads, terminal one end in 16-pin DIP jack to mate with 16-pin DIP IC-type socket  
 1-Heatsink for IC7, 50-watts dissipation minimum (Radio Shack 276-1361)  
 Printed-circuit fabrication materials, mounting hardware, knob, case, heatsink compound, terminal strip, solder, wire, line cord with moulded 3-prong AC plug (P1), etc.

An etched and drilled printed-circuit board is available from Micro Power Systems, RFD #2, Rt. 4-A, Enfield, NH 03748. Price is \$11.50 and includes shipping and handling charges. Please note: All boards shipped UPS unless otherwise specified. Visa and MasterCard accepted. Be sure to give all information on card.



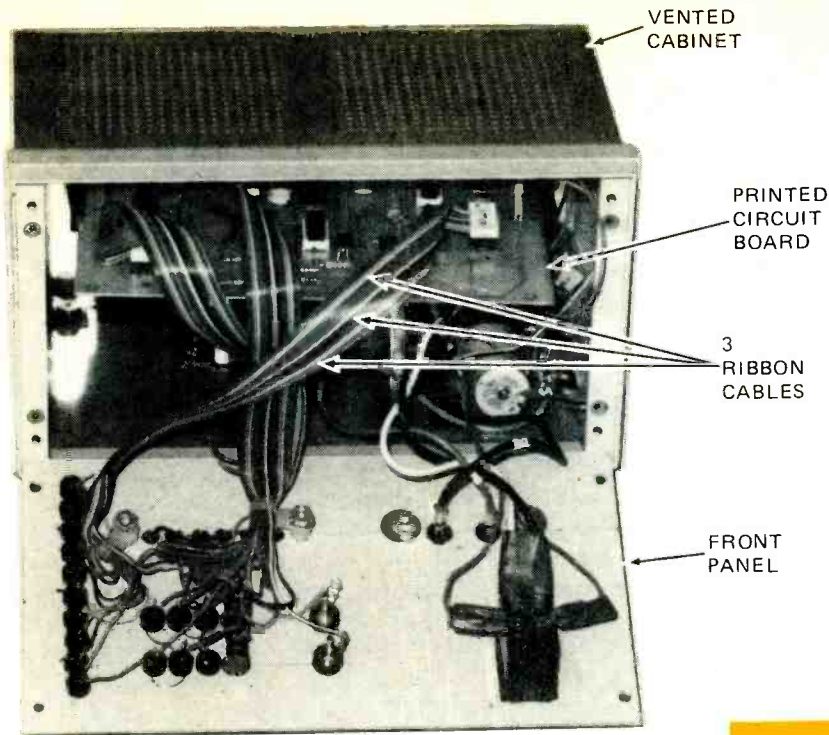

DROP THE FRONT PANEL and the interior looks like a well-designed project with good construction practice. Ribbon cables are used to interconnect components on the front panel with the printed-circuit board. Thus, in the event that faulty wiring occurs in construction, it can be quickly traced by using the cable's color code. The printed-circuit board is held in place by holders specially designed for that purpose. However, you may want to go the less expensive route by using low-cost standoff posts which do the same job at a fraction of the cost.

in the same manner and can only be used for TTL and *positive* CMOS circuits.

The clock frequency is adjusted by potentiometer R24. By selecting a range tap and changing the setting of R24, any desired frequency can be obtained within the range selected. The outputs B through F are CMOS outputs with a 5-volt swing. External buffering may be necessary for some circuits. The 4060 CMOS divider chip, IC6, has a fan out of 2 74LS loads, and cannot drive 7400 TTL devices directly.

The Digital Prototyping System should give you everything you need to easily design many more projects in the future. Debugging is also a snap due to the elimination of all the extra leads and wires that normally clutter up a breadboard. **SP**

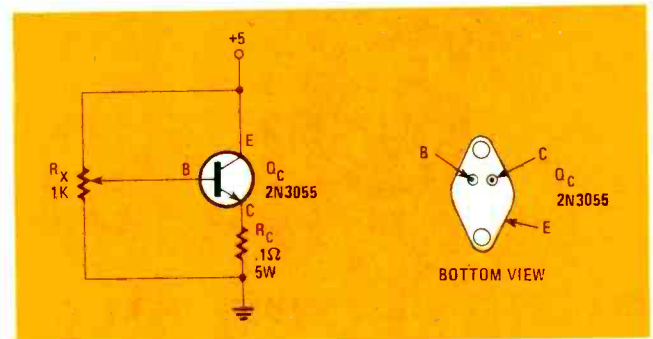
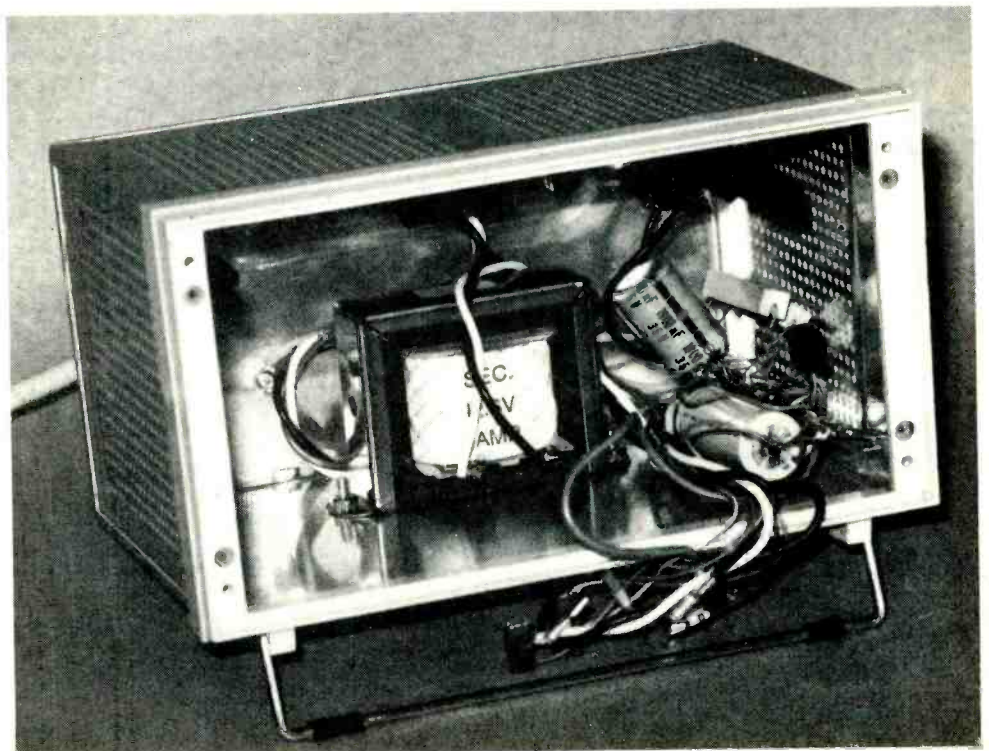

FIG. 6. HERE'S A SIMPLE CALIBRATION LOAD for the Digital Prototyping System. Make brief current tests of 15 seconds or less; otherwise, the transistor will overheat. Even a brief test will raise the transistor case temperature sufficient to burn flesh.

WITH THE FRONT PANEL completely removed and the printed-circuit board slid out of its holders, the project looks very much like a simple power supply—which it really is! The add-on circuits make the unit extremely valuable to the circuit designer and prototyper, who must monitor  $V_{CC}$  current and have knowledge of the switching action in the externally-powered circuit.



# Radio- Electronics

BUILD FOR LESS THAN \$10  
DIGITAL LOGIC PROBE

\$1.25 AUG. 1980

6 audio test accessories to build  
Tuning in worldwide SW  
Step-by-step TV IF align

**AVAILABLE — COMPLETE  
for the FIRST TIME!**



## BUILD YOUR OWN ROBOT!

Send today for your 52-page (8½ × 11") booklet containing complete reprints of all eleven articles in the Build Your Own Robot series by Jim Gupton.

This all-inclusive reprint gives you all the data you need to build your own Robot.

■ TELLS EVERYTHING YOU NEED TO KNOW to build the Unicorn-1 Robot without the need for an engineering degree or special equipment.

The robot is fully mobile with manipulator arms to grasp, lift and carry.

■ MANIPULATOR ARMS and end-effectors (hands) are what enable the robot to perform useful tasks. Details of construction techniques and considerations are fully explored.

■ MOBILITY BASE is not a lunar space station. It is the drive system that permits the robot to move from here to there. Full construction details along with a discussion of power sources is included.

■ THE BODY—FRAME AND ROTATION MECHANISM. This is the part that makes Unicorn-1 look like a robot. Wood and Formica are the materials for the body. Motors and gears are what make it function.

■ COMMUNICATIONS. How you can tell your robot what to do. Preprogramming techniques...radio control ...computer control are all detailed.

■ SENSORS. How to add sensors so your robot doesn't bump into things.

**Radio-  
Electronics**

Robot Reprints  
200 Park Ave. South  
New York, N.Y. 10003

SP-7

Please print

I want to order \_\_\_\_\_ reprints @\$12.00 plus \$1.00 postage and handling for U.S., Canada and Mexico. Add 96¢ sales tax for New York State residents only. U.S. Funds only.

I want to order \_\_\_\_\_ reprints @\$12.00 plus \$3.00 Air Postage and handling for all other countries. U.S. Funds only.

Allow 6-8 weeks for delivery.

(Name)

(Street address)

(City)

(State)

(Zip)

We do not bill, check must be enclosed.

If you like to make things work...and then find out why they work—

# you could be getting paid for doing something you really enjoy!

Learn electronics...right on up to an Associate Degree...in your own home without giving up your present job or income.

People who really like their work get ahead faster. And, when your natural abilities match the job requirements, you have an extra advantage. When you use practical training to sharpen your skills, your odds are better for keeping your job even if others are losing theirs. So, if you find satisfaction and interest in making things work, a career in electronics may be for you.

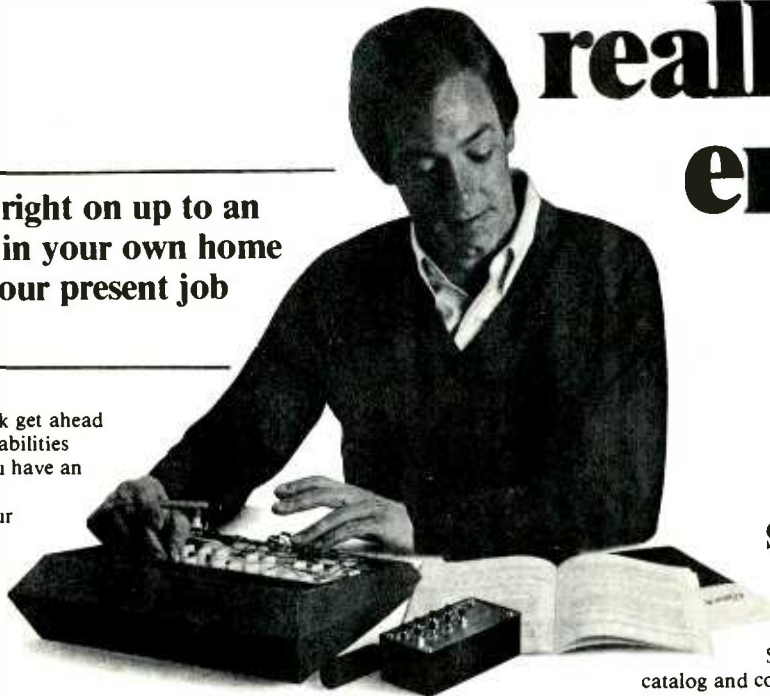

## START MAKING THINGS WORK FOR YOU

Send today for the CIE school catalog and complete package of career information. It's all FREE, and it will help you decide where you want to start and how far you want to go. For your convenience, we'll try to have a school representative contact you to review the various educational programs and assist in course selection. Just mail the postage-paid card or write, mentioning the name and date of this magazine. We want to help you make things work, so send for your FREE school catalog today!

## WHY ELECTRONICS IN THE 80's

Opportunity.

The field of electronics simply offers more career opportunities — and more job security — than most other fields today. Take digital technology, for example. Much of the new telecommunications, data processing, and production equipment depends upon sophisticated microprocessors to receive, sort, and send digital signals in microseconds. Two of CIE's newest home study courses combine digital electronics theory with actual experience on digital equipment. Successful completion of either one of those courses is creditable toward CIE's Associate Degree program. That's right...you can earn an Associate Degree without attending a single class session.

## MAKING THINGS WORK

Many of CIE's Career Courses stress "hands-on" training. We believe textbook knowledge is important — but it's just as important to know how to apply your book learning in practical situations. From basic circuitry in CIE's Personal Training Laboratory in several Career Courses, through the Microprocessor Training Laboratory in the Associate Degree program, CIE helps channel your desire to "make things work" into skills you can sell.

## IN A CLASS BY YOURSELF

One of the great benefits of home study is the independence it gives you. You study where and when you want to. You move as fast as you can handle it. There's no classroom to go to because with CIE, the classroom comes to you! But, you're never alone. When you request help, the CIE electronics expert best qualified will personally respond in writing.

## SET YOUR OWN GOALS

CIE's wide selection of courses gives you many options. You start with a Career Course that suits your talents. Then, since more than half of CIE's courses include a series of optional lessons to prepare you to pass the government-administered FCC License exam, you can get an FCC License...a requirement for *some* electronics jobs and a credential for *all* electronics jobs. You may then go on and earn an Associate in Applied Science Degree in Electronics Engineering Technology. It's all up to you!

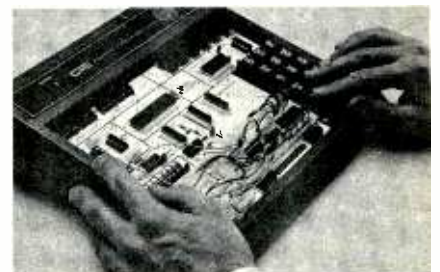

*CIE's Microprocessor Training Laboratory, an integral part of the Associate Degree program, lets the advanced student apply digital technology in many of the same ways electronics professionals do.*

**CIE** **Cleveland Institute of Electronics, Inc.**  
1776 East 17th Street, Cleveland, Ohio 44114  
Accredited Member National Home Study Council

# SOUNDBOX 80

ROBERT MURR

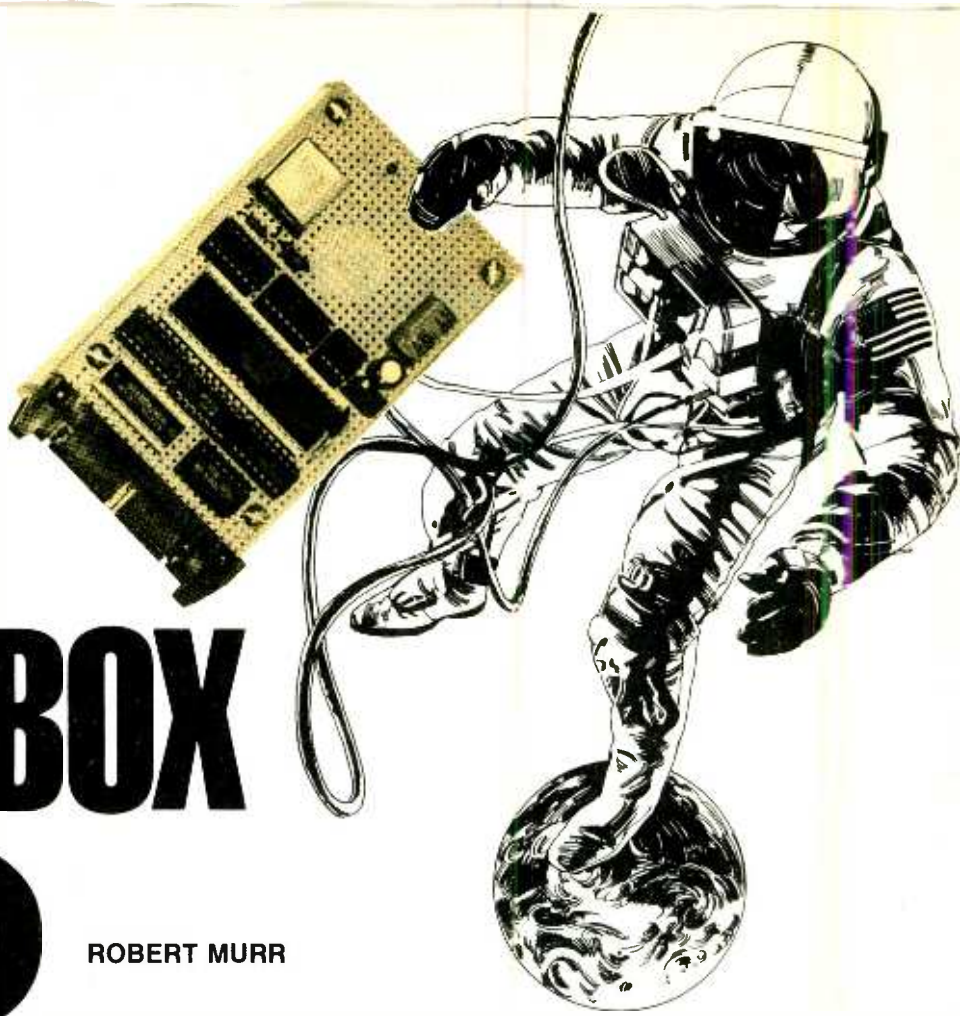

***If your TRS-80 game programs are as quiet as an end-term examination, then think what sounds like Booiinnnggg, Zapppp, Whizzzzz will do to keep your play-action popping.***

MANY READERS HAVE ENJOYED PLAYING GAMES ON THE TRS-80 Model I. Yet something definitely felt missing as we brought the *alien* within our sights, pressed the fire button, and simply saw the word "bang" on our screen. Now with a little hardware and some programming practice we can make these games come to life with sound from Soundbox-80.

Though the integrated circuit behind all that has been around a while, and has been used in other computers, it has not been interfaced specifically to the TRS-80. In this article, I will discuss such an interface circuit, how it works, how to use it, and how to build your Soundbox-80.

## The circuit

Programmable sound generator (PSG) chip IC1, the AY-3-8910 by General Instruments, is designed to send and receive data over the eight-data lines. That data is transmitted between the chip's set of 16 registers, which are used to select the desired sound, and the computer's bidirectional data bus. The circuit of Fig. 1 includes a 74LS245 octal, tri-state bus transceiver integrated circuit, IC2, which serves that purpose.

The majority of the Soundbox-80 circuit in Fig. 1 is used for address decoding and chip-enable logic. For the tri-state buffer, IC2, there are two controls: enable (IN), pin 19; and direction (DIR), pin 1. The enable control signal must pulse low during any transaction between the computer and the sound circuit; otherwise, the outputs are tri-stated in both directions. The direction-control signal, pin 1, simply decides whether the data will be shipped from Soundbox-80 to the computer, or vice-versa. The enable logic for the AY-3-8910, IC1, must also be carefully planned. The requirements

TABLE 1 PSG (IC1) ENABLE LOGIC

B DIR	BC2	BC1	PSG (IC1) FUNCTION
0	1	0	Inactive
0	1	1	Read from PSG
1	1	0	Write to PSG
1	1	1	Latch address

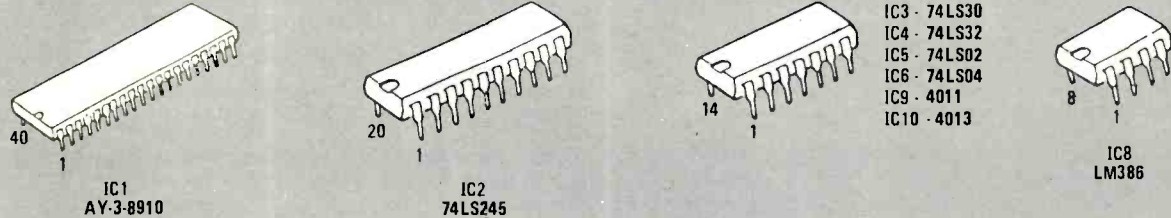
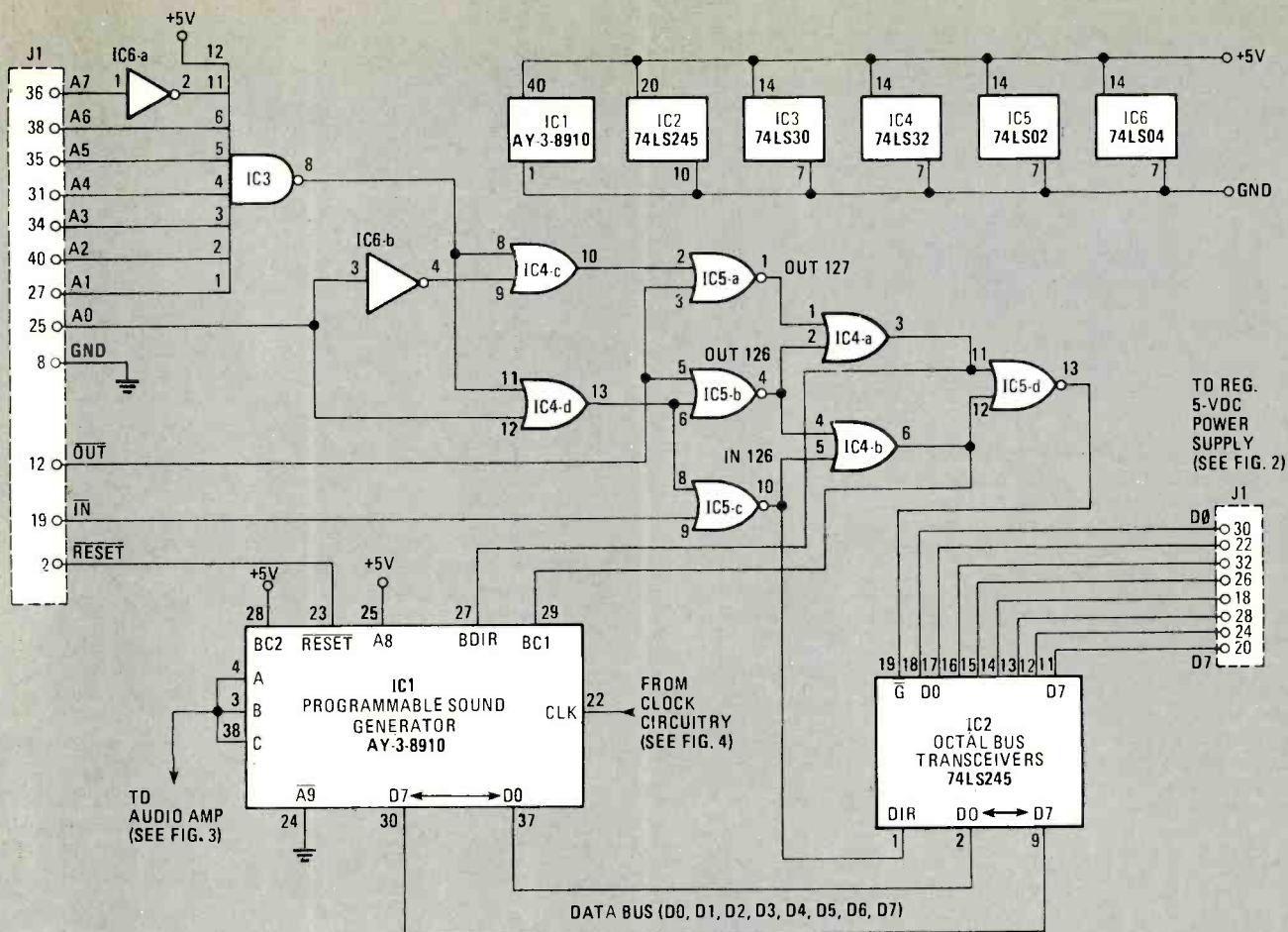

**FIG. 1—SCHEMATIC DIAGRAM FOR THE PROGRAMMABLE SOUND GENERATOR section of Soundbox-80—the noisy addition to your TRS-80. The text takes you by the hand through the schematic diagram which, in effect, is a basic course in logic theory. The associated power-supply circuit, audio circuit, and clock circuit are provided in the following figures—all of which are part of Soundbox-80.**

are summarized in Table 1. The BDIR signal, pin 2, must go low whenever writing or latching to the internal programmable sound generator, IC1. Since the BC2 input (pin 28) does not need to be used, it is tied to the +5-volt supply. The BC1 signal, pin 29, only goes high during the read and latch operations.

The logic to create those enable functions begins with the address decoder, made of IC3 and IC6-a, which is an inverter used to select the desired port. It can be replaced by any combination of inverters on the address lines A2 through A7. The output of IC3 goes logic low whenever the lowest 8 bits of the address buss are decimal 126 or 127. That output is combined separately with the inverted and non-inverted A0. The lowest address line is used to select whether the operation is latching or writing to the chip. IC5-a, b, and c are used so that the circuit will only respond during an input or

output instruction. They are again combined and are used to feed the master enable of IC2.

Soundbox-80 needs only a regulated 5-volt power supply (you cannot power it from the 5-volt pin on the TRS-80 edge connector) a clock, and an audio amplifier. Schematic diagrams for each of them are illustrated in Fig. 2, 3 and 4. The schematic diagrams for Soundbox-80 (Figs. 1 through 4) may be built on a circuit board or wire-wrapped. The connections to the TRS-80 are made via a 40-pin, card-edge connector J1.

The power supply of Fig. 2 uses a 6.3-VAC transformer, a full-wave bridge rectifier, and a 7805 five-volt regulator chip. The 2200  $\mu$ F electrolytic capacitor is used to filter the DC before the input of the regulator; and the 0.1  $\mu$ F capacitor used to reduce the noise on the 5-volt output. Additional 0.1  $\mu$ F disk capacitors may be tied directly across the  $V_{CC}$  and

**TABLE 2  
OUTPUT TO THE PSG (IC1)**

10 OUT 126,5	;Latch register 5
20 OUT 127,20	;Load register 5 with 20
30 OUT 127,30	;Load register 5 with 30

**TABLE 3  
INPUT FROM THE PSG (IC1)**

10 OUT 126,5	;Latch register 5
20 X = INP(126)	;Load X with contents of register 5
30 PRINT X	;Print contents of register 5

**FIG. 2—THE POWER-SUPPLY CIRCUIT** is the usual regulated 5-volt DC supply that powers so many projects built by experimenters. Plug P1 and jack J2 should be polarized to avoid accidental voltage reversal. Otherwise, *poof* go the IC's.

**FIG. 3—THE AUDIO-OUTPUT CIRCUIT** produces up to one-watt of audio power. That is too much for the small speaker built into Soundbox-80. Keep the volume setting down to avoid damage to the speaker. If you wish, the LM386 can power a heavy-duty speaker externally connected, or, to spare the ears of those around you, connect a headphone.

ground pins of IC1 through IC10 circuits if the noise is still a problem and can be heard on the output of the audio amplifier, pin 5 of IC8 (Fig. 3). The power supply plugs into the unit via J1.

The audio output of the programmable sound generator, IC1, can be used to feed an external amplifier or the circuit of Fig. 3 may be used as a one-watt internal amplifier for Soundbox-80. The potentiometer, R4, is used as the volume control and the output of the LM386 is fed through the 470  $\mu$ F capacitor to an 8-ohm speaker.

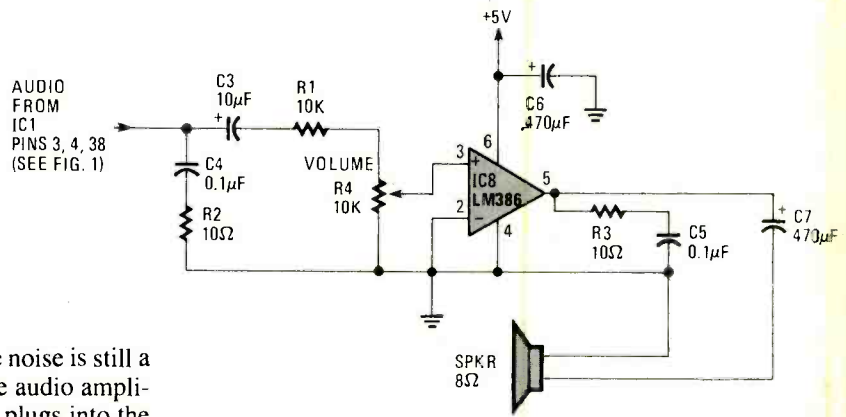
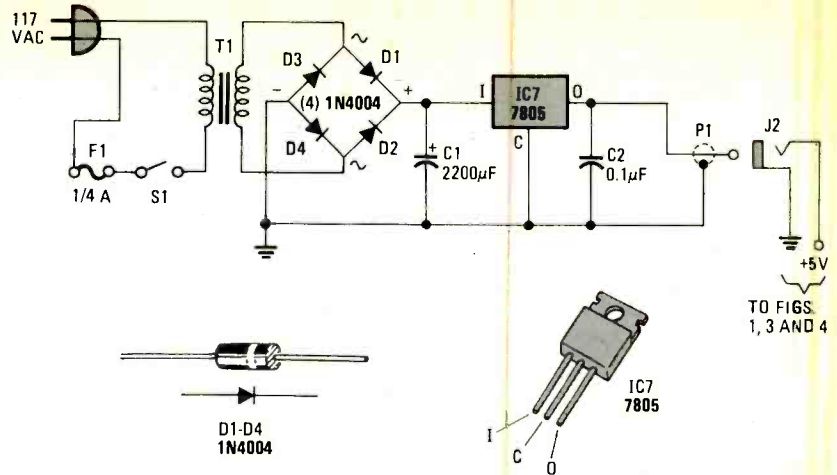

In Fig. 4 a standard 3.579545 MHz color-burst crystal, X1, is used as the basis of the oscillator circuit. The 4011 CMOS NAND gates IC9, are used to develop the 3.579545 MHz frequency and IC10, a 4013 CMOS dual D flip-flop, IC10, is used to divide the clock frequency by two to 1.7897725 MHz. That is within the 1-2 MHz range required by the PSG circuit in IC1.

### PARTS LIST FOR SOUNDBOX-80

#### SEMICONDUCTORS

- D1-D4—1N4004 silicon rectifier diode
- IC1—Programmable sound generator large-scale integrated circuit made by General Instrument
- IC2—75LS245 octal bus transceivers with 3-state outputs integrated circuit
- IC3—74LS30 8-input NAND gate integrated circuit
- IC4—74LS32 quad 2-input OR gate integrated circuit
- IC5—74LS02 quad 2-input NOR gate integrated circuit
- IC6—74LS04 hex inverter integrated circuit
- IC7—7805T + 5-volt regulator integrated circuit
- IC8—LM386 power audio amplifier integrated circuit
- IC9—4011 quad CMOS NAND gate integrated circuit
- IC10—4013 dual CMOS D flip-flop integrated circuit

#### RESISTORS

- All resistors are 1/4-watt, 5% fixed units unless otherwise specified
- R1—10,000-ohm
  - R2, R3—10-ohm
  - R4—10,000-ohm potentiometer, PC-board mount
  - R5—10-megohm
  - R6—300-ohm

#### CAPACITORS

- C1—2200- $\mu$ F, 15-WVDC electrolytic
- C2, C4, C5—.1- $\mu$ F, 15-WVDC Mylar
- C3—10- $\mu$ F, 15-WVDC, electrolytic
- C6, C7—470- $\mu$ F, 15-WVDC, electrolytic
- C8—20-pf, 10-WVDC, ceramic

#### ADDITIONAL PARTS AND MATERIALS

- F1—1/4-A fuse
- J1—40-pin card-edge connector
- J2—Two-circuit polarized jack to connect 5-volt supply; any type acceptable
- P1—Two-circuit polarized plug to mate with J2
- S1—SPST toggle or slide switch
- T1—Power transformer; 400 mA or better 6.3-to-12.6-VAC secondary winding
- X1—3.579545 MHz TV crystal; or similar type rated at 2-4 MHz
- SPKR—8-10-ohm speaker, 2-2½-in. diameter
- 1 40-pin DIP socket, 1 20-pin DIP socket, 6 14-pin DIP socket
- 1 8-pin DIP socket, plastic box, cement, wire, hardware, solder, etc.

THE **SOUNDBOX-80** looks like a haven for roosting integrated circuit chips. Sockets are used to mount the IC's. Make up your mind *before* you purchase the sockets as to the technique for wiring the unit. Wire-wrapping is best and calls for special sockets. If you prefer to interconnect and solder, wire-wrap sockets with their long posts with their long posts after the unit is wired. The plastic box is a garden-variety that's available almost everywhere. You may prefer a sturdier plastic box that most experimenters can buy at local electronics parts stores.

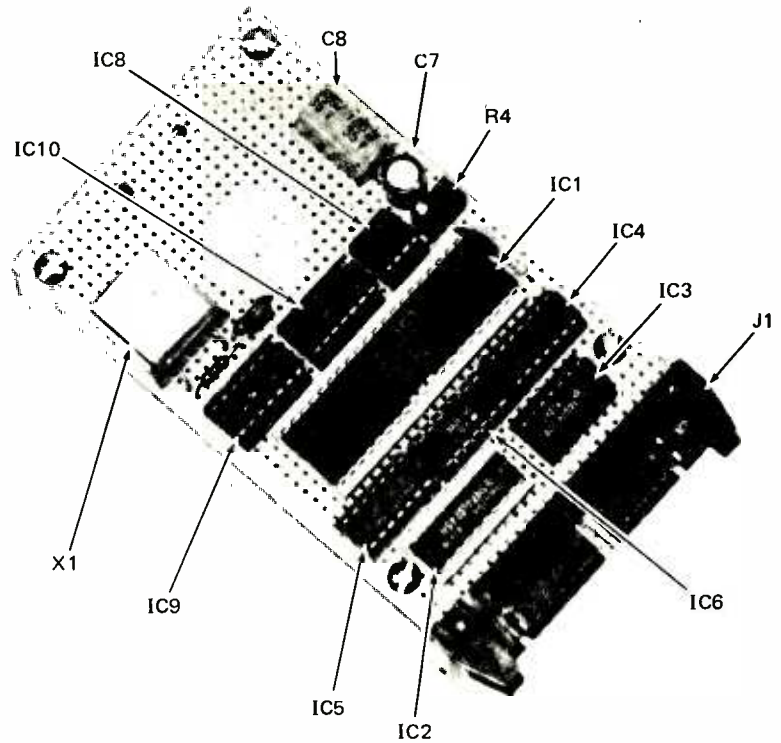
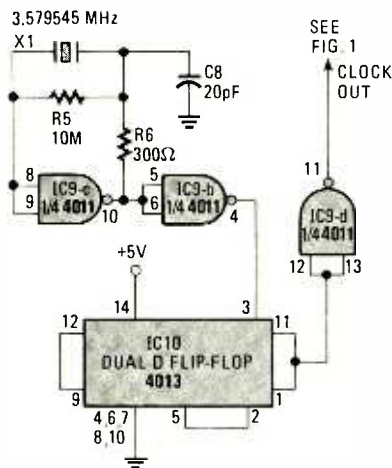

FIG. 4—HERE'S A HANDY CLOCK CIRCUIT that fills the bill for Soundbox-80 and just about any TTL and CMOS circuit requiring clock pulses in the megaHertz's. Since the 4013 is a dual integrated circuit unit, you may want to divide again to reduce the output clock pulse to one half.

More information on the operation of the programmable sound generator is available in the AY-3-8910 data manual, as well as a more detailed explanation of the logic required. The circuit may be built on a circuit board or wire-wrapped.

### Using Soundbox-80

The programmable sound generator, IC1, can be easily accessed from a BASIC program. The sequence for shipping data to one of the chip's registers is show in Table 2. Note that each time the data is to be transferred to or from a

different register than the time before, the new register number must first be latched. The sequence for reading information is shown in Table 3. A wide variety of sounds can be generated using that chip. The PSG can produce sounds ranging from explosions and laser fire to music with three-part harmony. The only way to get really familiar with it is through trial and error and the manufacturer's data manual.

The circuit can be built with relatively little cost or know-how. It will provide a new dimension for your TRS-80 and much entertainment for you. Now you can look toward a happy BOING, ZAAAAAAP and PINGGG!  
**SP**

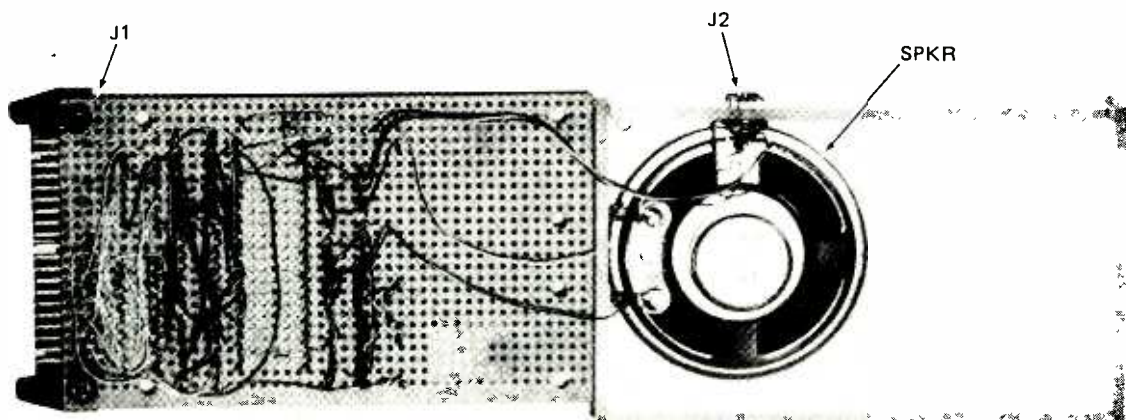

BELLY-UP VIEW of Soundbox-80 illustrates the rat's nest wiring that makes the programmable-sound generator circuit do its thing. Jack J2 is for connection to the external power supply. You may want to add a closed-circuit jack to hook-up an external loud speaker. If you prefer to connect a stereo headphone, use a closed-circuit stereo jack and connect both channels to the audio output so that both ear pieces produce sound.

# CUSTOM SOUND FOR YOUR CAR

LARRY GLENN

WHILE DETROIT AND TOKYO MIGHT HAVE PRICED THEIR "IRON" well beyond what you can afford, you don't have to wait for new "wheels" before you upgrade your car radio to stereo, or even to real high-fidelity status. Then again, maybe you had a tape player in the dash that some hoodlum ripped out, leaving a large gaping hole. Either way, you can add or retrofit one of the new hi-fi or super-fi AM/FM-stereo, cassette-tape radios in just a couple of hours. What you save on installation can pay for a pair of super-duper multi-way speakers, or half the cost of the radio itself.

The speakers themselves are no problem. Virtually every modern dash is pre-moulded for miniature stereo speakers. If you like something other than a thin, tinny sound—which is what you'll get from mini-size dashboard speakers—you'll find that in most instances the rear deck has been pre-cut for larger speakers of the 5 × 7-inch or 6 × 9-inch variety, or for some other size that will sound better than the itty-bitty speakers generally used in the dash.

Usually, all you have to do is fit the speakers to the existing cutouts and run the wiring to the radio location, leaving a couple of feet of slack that can be folded behind the dash and taped in place.

The real nitty-gritty of the installation will be fitting the

radio, because so-called "universal" radios really aren't universal; they are anything but...! The photographs show the highlights of an in-dash radio installation.

## Universal what?

Before we proceed, let's straighten out the word "universal," because most of the car radios are sold as either a universal or DIN type. DIN simply means it will fit directly into the dash of European cars. Europe has a standard for virtually everything. It might also mean the radio of your choice won't fit at all. It appears that given any two measurements, the Europeans will use the most difficult and expensive size as a standard. On the other hand, the term universal generally means; the distance between the two sets of controls (volume, tone, tuning, etc.) can be adjusted. Nothing else other than the shafts are guaranteed to fit into your car's mounting holes.

The term universal came about this way. Up until a few years ago aftermarket radios generally were packaged with an assortment of hardware and front-panel accessories specifically matched to a particular car. At worst, the installer could use some of the supplied panel accessories, such as filler panels, to make it appear the radio was factory

**YOU GET JUST ENOUGH** hardware with a modern "universal" aftermarket radio to install it; possibly, a full-length wiring harness with the more expensive radios. This harness has the speaker terminals and speaker/power connector pre-attached.

**PENCIL POINTS TO** the clamp and chassis holes that permit the control-shaft spacing to be easily and rapidly adjusted for your particular dashboard. Clamp should not be discarded. It is the only truly "universal" part of a "universal" radio.

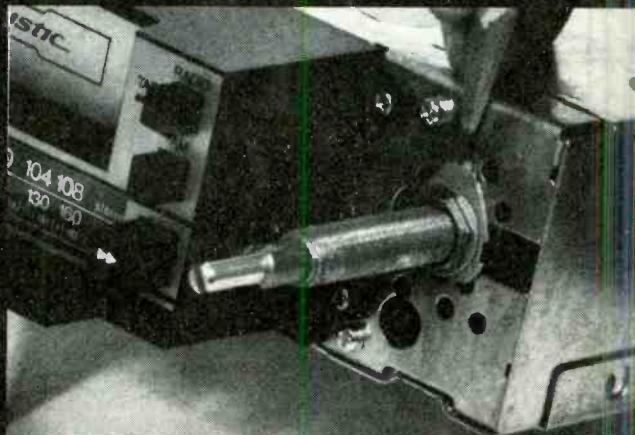
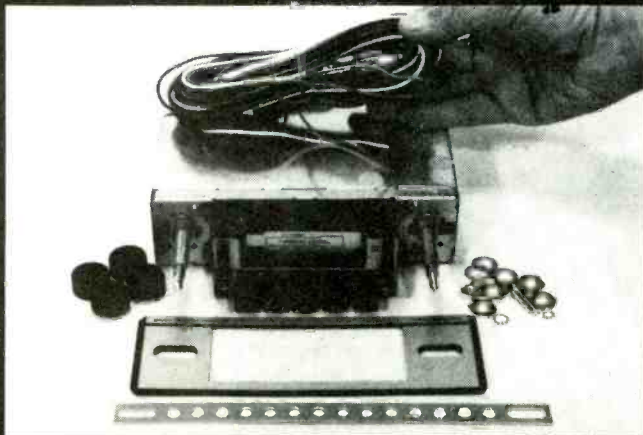



**If you can buy it—  
you can install it!  
Shopping wise and  
installing it yourself  
may cut the radio's  
final cost in half!**

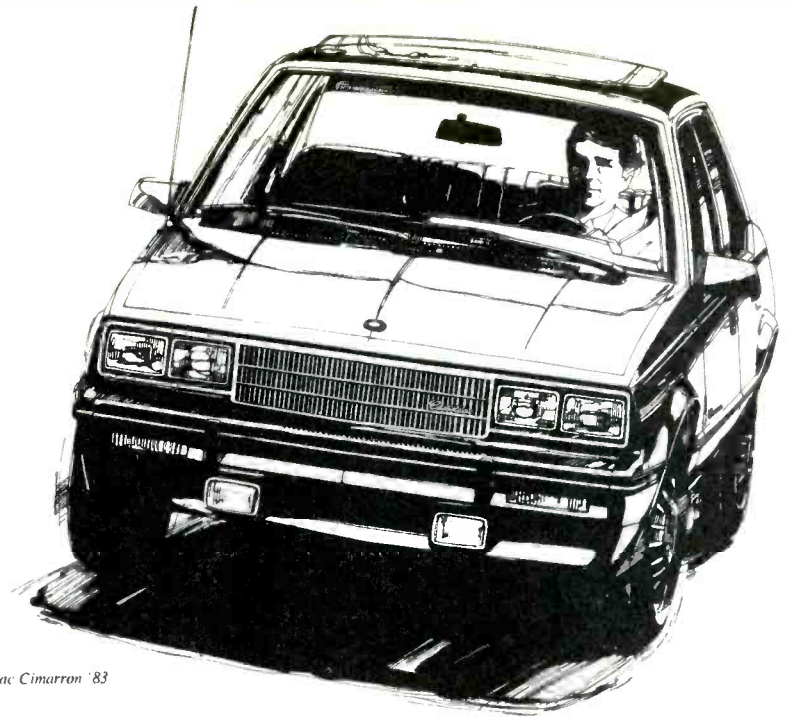

*Courtesy of Cadillac Cimarron '83*

equipment. Also, some cars, such as those from Chrysler, require a special mounting bracket if the car wasn't sold with a radio. Usually, the special bracket was available from the same people that made the radio. In a sense, the aftermarket radios were truly universal because they came with mounting and trim hardware. At the very worst, the installer might have to purchase a special mounting bracket.

Today, you get none of the special hardware with a universal radio. The average person can't even get the mounting bracket if it's needed because most stores that sell this item are only "wholesale" or "for the trade." If you're stuck for a bracket or trim panel, try a junk yard. Generally, they'll let you have either for a couple of dollars, which is a lot less than you would pay a dealer for the item. For example, the final trim panel shown in the photographs was obtained for \$1 from a local "junkie." In some junk yards you have to do the stripping, so bring your tools.

#### **What you get**

OK! Let's get on with an installation. When you open the radio you'll find it's packaged with assorted mounting nuts, perhaps a few screws, knobs, a strong metal strap, a trim panel, possibly some electrician's "wire nuts" for splices,

and possibly some wires attached to a connector that provides the speaker and power connections, or a separate wire might be used for the power.

Depending on the price of the radio, or how greedy the manufacturer wants to be, the connector(s) might be attached to little stubs of wire which must be spliced into your existing wiring (or wiring you install), or the connectors might be attached to a wiring harness that will stretch from the rear deck speakers to the dash with a few feet left over to spare.

A really decent harness will also have push-on connectors for the speaker so you don't have to lie flat on your back in the car's trunk trying to solder wires on the speaker terminals. The harness will also be color-coded so you get the speaker phasing correct the first time. Regardless whether you're using a harness supplied with the radio or one you have made yourself, run the wires up to the radio's location before you install the radio. There probably won't be room for your hands behind the dash after the radio is installed.

If the kit is provided with wire nuts, don't use them for any connections already in the vehicle, such as existing speaker wires, the power wire, etc. To use the wire nuts you must cut and strip the existing wires. This has produced many heartaches for installers who found the wires were too short,

**HERE IS THE ONLY metal part of an electrical Quick-connect. It taps wiring without actually cutting through the copper wires. Wires are placed in "tunnels" or grooves, plastic hinge placed over them, and gently squeezed by pliers to make connection.**

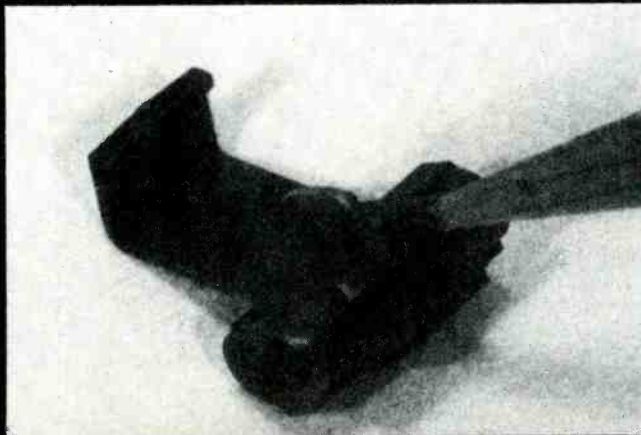

**FOLD THE PLASTIC HINGE over and squeeze the Quick-connect with pliers to drive the metal gizmo through the wires' insulation. Since everything is encased in plastic you can make the power connection while power is on (if necessary), but don't do it!**

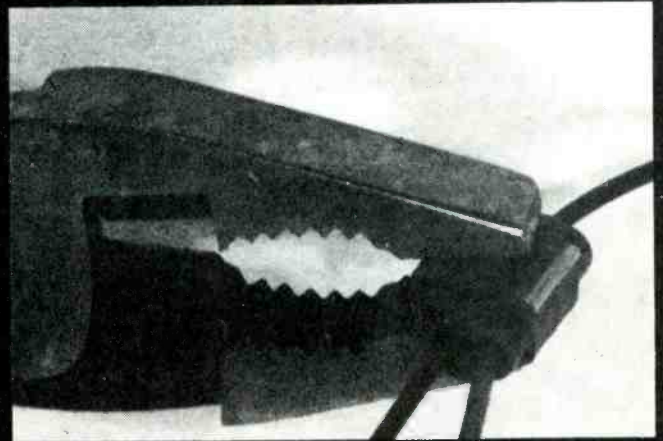

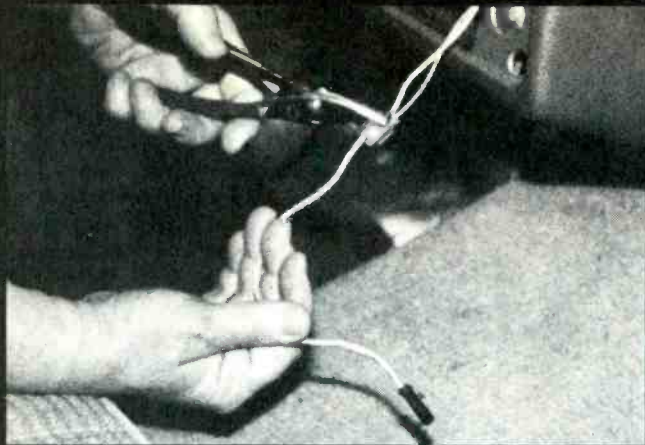

**THE CIGARETTE LIGHTER** power wire or the vehicle's original radio power wire is a good place to splice in radio's power wire. Should you make a mistake, Quick-connect comes apart easily—tape the original wire where the gizmo cut through the insulation.

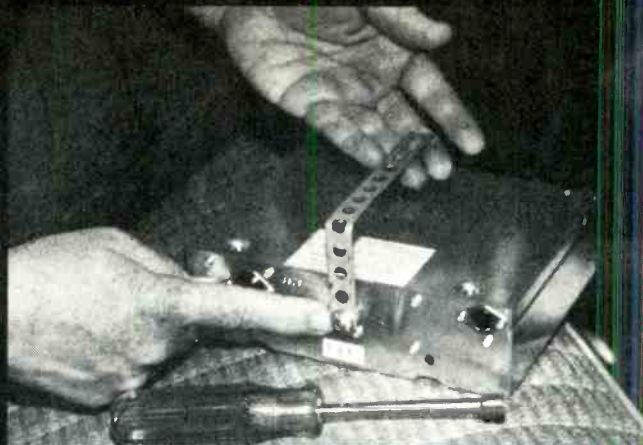

**THE PERFORATED STRAP** supplied with the radio provides both rear support and the ground connection for the radio. Bend it to the required shape before you install the radio. If possible, also get one end secured before the new radio is slid into position.

too fragile, or whatever. A more secure and easy-to-use connector is something called a "Quick-connect," or "Scotch-lok," the plastic device shown in the photos. The beauty of the Quick-connect is that it's fully insulated, and you can make a splice with power on the circuit. The device is a sort of plastic dual tunnel with a small metal *gizmo* in the center and a hinged plastic cover. You place the wire to be tapped in one tunnel, insert the connecting wire in the other tunnel, fold the plastic cover and squeeze with pliers, thereby driving the metal *gizmo* into the pair of wires where it pierces the insulation when making the connection without cutting the wires. This device works best on stranded wire. Solid wire gets nicked and breaks easily.

If you need to tap the vehicle's wiring for radio power use the original power wire for the factory radio, or the wire meant for the cigarette lighter. It often can be pulled directly off the back of the lighter assembly, and since it usually gets turned off by the ignition lock, it's a good power source for the radio.

#### How to do it

Before starting the actual installation of the radio, adjust the spacing of the control shafts. Measure the separation of the shaft or control holes on your dash, then loosen the nuts

on the shafts enough so their locking clamps can be slipped out of their holes, set the shafts to the correct spacing, and then rotate the clamps so they easily fall into a hole drilled in the chassis around the shaft. Then tighten the shaft nuts. Do not discard the clamps and try to hold the shafts in place with just the nuts—it won't work. You'll either snap the nuts or a shaft(s), or the shafts will work loose in a few days. The clamps must be used. If they don't easily fit in a hole try a different orientation for the clamps; at some point they will drop directly into a matching hole.

#### Strap it

Next, locate the metal strap with the holes that was supplied with the radio. The instruction manual that came with the radio probably shows the strap hanging from some part of the dash to a screw on the back of the radio, thereby supporting the radio. The radio does need support if it has a tape player because tape radios are relatively large; they place a lot of strain on the dash if all that holds the thing in place are a couple of nuts on the front panel. Unfortunately, most modern cars don't have any place to which you can attach the strap as shown in the radio's manual. The "hanging strap" might have been possible five to twenty years ago, but the modern dash probably is plastic, is molded, and has no room

**GET AN ORIGINAL-EQUIPMENT** trimplate from your local junk yard and cement it to the dash if necessary. Fill in any open spaces in the new trimplate with strips of scrap rubber or new shoe leather. Cement these strips to the trimplate.

**USING AN INSULATED ALIGNMENT** SCREWDRIVER adjust the AM "trimmer" for maximum sensitivity to "high end" AM stations. Set the radio's dial to a weak station near 1400 kHz on the dial, raise the car antenna, and tune for maximum volume.





**USE A DEEPWELL SOCKET WRENCH** to tighten the nuts on the control shafts. Pliers, wrenches, and other ill-suited tools only cause damage to the control shafts, which aren't all that firm and may be damaged doing a task they are not designed to do!



**WHAT'S THIS!!!** The trimplate doesn't fit! Correct! The days are long past when a universal trimplate that actually fits all cars is supplied with a universal radio. You will have to do considerable material fabrication to make a new trimplate fit the old gap.

for your hands, a tool, or even a screw for the strap.

In some vehicles the strap can be routed under the radio to a metal support plate for the dash, or the reinforcement for the ash tray. Whatever, simply bend the strap so it comes from under the radio. The strap is iron and not the easiest thing to bend—that's why it makes a good bracket. Use a vise to hold the strap and hammer it to shape.

Try to get the strap in place before installing the radio—it might not be possible later. Either attach the strap to the radio, saving the support connection for last, or vice versa.

#### There's more

Then install the radio in the dash, using a deepwell socket wrench to secure the shaft nuts. Don't try to force a standard socket wrench on the shaft—it's not deep enough—and don't use pliers; that will just chew up the controls. You have most likely spent at least \$100 on the car radio, possibly \$200 or \$300; spend a few dollars for a deepwell socket wrench and do the job the right way. By the way, don't try to use long-nose pliers for the shaft nuts. You'll probably ruin the pliers, and they cost more than deepwell socket wrenches.

In many instances you're going to find the trimplate doesn't fit properly because there is no such thing as a universal trimplate. Most likely, there will be holes and

openings showing around the trimplate, or it's just plain ugly. (I think they train student designers on radio trim accessories.) Try your local junk yard for an original-equipment trimplate. Even if its cutout is somewhat oversize, a few strips of black rubber or leather (scrap from a shoe repair shop) cemented to the "factory" trimplate will look like original equipment to all but the most thorough scrutiny. If you don't have the hardware to install an original-equipment trimplate use a few drops of an adhesive such as "Barge"—it comes in a tube and is the same stuff used to cement rubber soles to shoes. It will certainly hold the trimplate.

You're almost done. Install the knobs, plug-in the speaker, power, and antenna wires, tune the radio to a weak station near 1400 kHz, and using an insulated alignment screwdriver adjust the "AM trimmer" for maximum signal strength. On cassette radios the trimmer is often reached through the cassette loading slot. On other models it is accessible through a hole in the rear or the side of the chassis.

Finally, re-install any ash tray, glove box, or accessory hardware you might have had to remove to get at the radio's location. If you have tapped into the cigarette lighter's wiring make certain you have re-connected it to the back of the lighter assembly. **SP**

**FINALLY, RE-INSTALL** the ash tray or glove box if they were removed when installing the radio. Make certain you re-connect the cigarette lighter. If your car has missing hardware and worn parts on the dashboard, try to pick those up at the junk yard.



**SNAP IN A CASSETTE** when you tire of listening to the good sound your in-dash radio is playing. If you installed an AM/FM unit, then FM is for you when driving about town or the local countryside. For long rides cassettes and AM listening is best.



# Make Your Own COMPUTER CABLES

JOHN SMITH-RICHARDSON

***Computer cables either stock items or custom design are very expensive. Make them yourself and experience a retail savings from 50 to 75 percent!***

IT IS SAID, NOT COMPLETELY IN JEST, THAT POLAROID COULD afford to give their cameras away, because once you own one you're married to Polaroid forever. Only they make the film; they can charge what the traffic will bear, and that's economics!

The same can be said of computer-peripheral manufacturers. There are many places to get a discount on hardware such as modems, printers, and the other gizmos that make personal computing a pleasure, but in almost all instances the gear comes without cables. When you ask for the cables, you then find out why they can sell the peripherals at such fabulous discounts—most of the profit is in the cables. For example, an ordinary Centronics-type printer cable that you can assemble yourself for about \$18 costs between \$40 and

\$60 at your local computer emporium. And ordinary RS-232 extension cables for a modem, printer, or a terminal are a literal gold mine: a 5-foot length with something like \$13 worth of parts sells for \$40 and up, while a simple gender-reverser you can throw together from some junk connectors starts at \$30.

The best way to overcome the greed of the computer shops, and save a bundle at the same time, is to simply make your own cables. Sometimes it's a snap, 10-minute job to assemble the equivalent of a \$60 printer cable, other times it takes a little more effort because some of the manufacturers throw a "hook" into their connections to force you to buy their cables. For example, the non-standard Apple parallel printer connections are legendary. The quixotic numbering

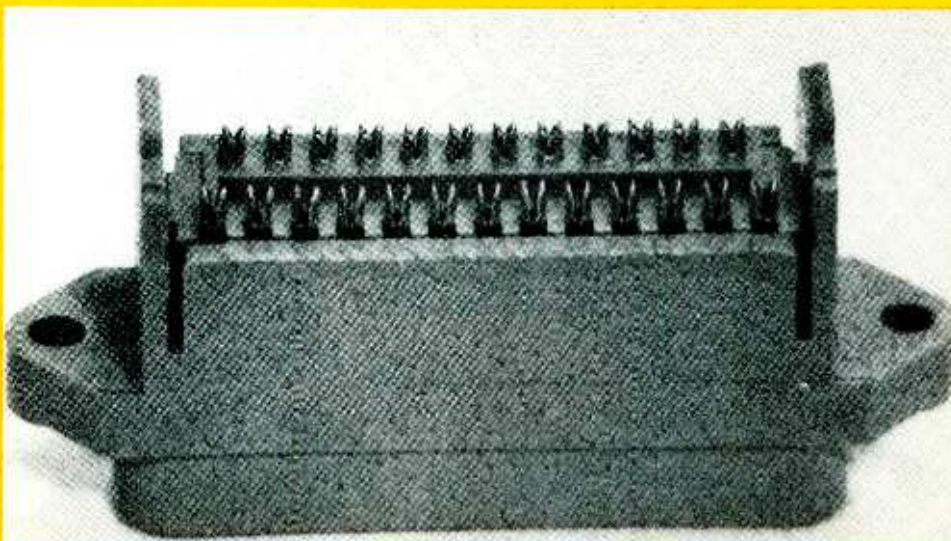

**THE CONNECTORS** specifically made for ribbon cable have razor-sharp "insulation displacement" terminals. When the ribbon is pushed against the terminals the "knives" slice through the insulation and the wire makes contact with the terminal(s). No soldering of any kind is required.

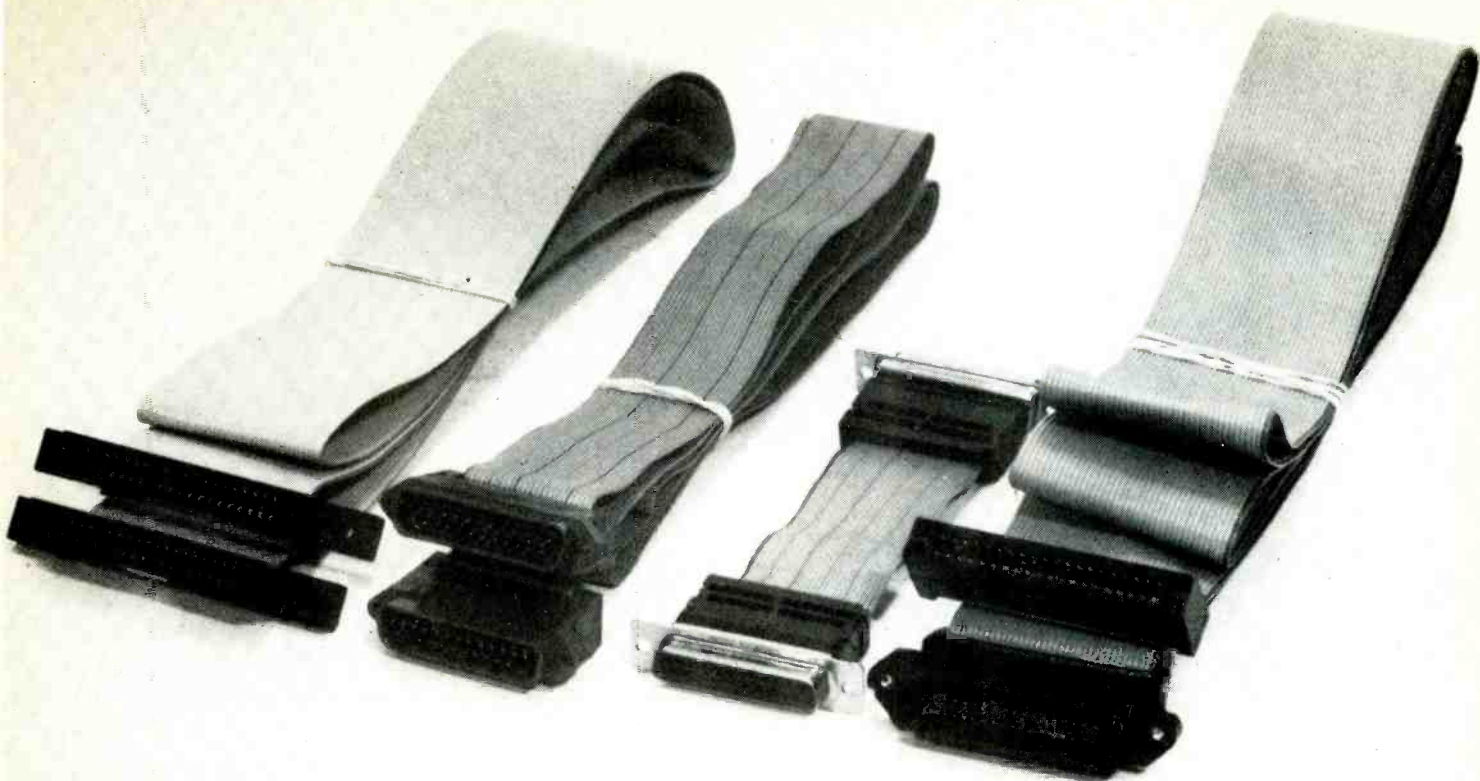

of Radio Shack's original printer-port connections led to many repairs during the warranty period—and many users believe it was innumerable *freebie* repairs that convinced Radio Shack to use standard terminal numbering. Then there was Heathkit with an RS-232 terminal #20 connection known only to Heathkit.

But does anyone every learn? Never! The latest version of the Osborne computer instruction manual has a completely erroneous set of parallel-printer connections; after you blow your mind and a few days work, most users wind up spending \$40 to \$60 for an "approved" cable. And let us not forget that if you use a standard "reversed" modem cable between an Osborne and a professional RS-232 modem the computer will lock-up. Or how about Radio Shack's Color Computer? The rest of the world uses a D-connector for a serial interface; the CoCo uses a 4-terminal DIN connector.

When you come right down to it, in many instances there is no such thing as a standard cable. If one end is standard the other probably isn't; but that's no reason why you still can't save *big bucks* by making your own cables.

Most computer cables can be easily assembled from a small assortment of parts: some ribbon cable, press-fit ribbon connectors, multi-wire (round) cable with solder connectors, or some combination of ribbon and solder connectors. At most, it's simply a question of using the easiest cable and connector for a given job.

Ribbon cable is usually preferred because the connectors clamp on; they are not soldered. Ribbon cable consists of many individual plastic-insulated wires moulded side-by-side. It's usually available in specific wire widths, such as 20, 26, 30, 36, or 40 wires. If you need something like 38 wires you simply strip away 2 wires from a 40-wire ribbon cable. Ribbon cable can be either all one color with one single wire on either side a different color, or every fifth wire

might be a different color to help you count from either end, or every group of wires might have individual colors, say all colors of the rainbow repeated in sequence.

Regardless how it's done, the two outside wires are never the same color unless someone has deliberately gone out of their way to be stupid by stripping multi-color wire in such a manner the two outside wires are the same color. The outside wires are polarized tracers and *must* be a different color. If you use conventional ribbon cable one side wire will be red, or black, or blue, while the other wires are one other color. If every fifth wire is color-coded, only one outside wire will be color marked.

To save yourself the heartache of an inadvertently "blown" peripheral, standardize and use the color-coded wire as the #1 lead connected to the #1 terminal. Regardless of what the manufacturers of your computer and peripherals do, your cables will be OK if you use one, and only one, cable wiring standard.

Ribbon cable comes in several different gauges. The stuff from Radio Shack, however, is the easiest to locate and is among the least expensive; it works just fine because its insulation appears to be the exact thickness required for most ribbon-type connectors. If the wire is too heavy, you can easily damage a connector during assembly.

Unfortunately, while I have always been able to purchase the wire in a Radio Shack store I have never been able to find it in the catalog, though it must be there somewhere.

At times, you'll have had no choice but to use solder connections and you'll create the least problems if you: A) use a "light" iron (about 22 watts) with an ultra-thin (1/6-inch) soldering tip; B) use the so-called "wire type" solder of #22 or #24 gauge; and C) you twist the wire ends very, very tightly and tin them solid from the insulation to the tip before you try to install them on the connector's terminals.

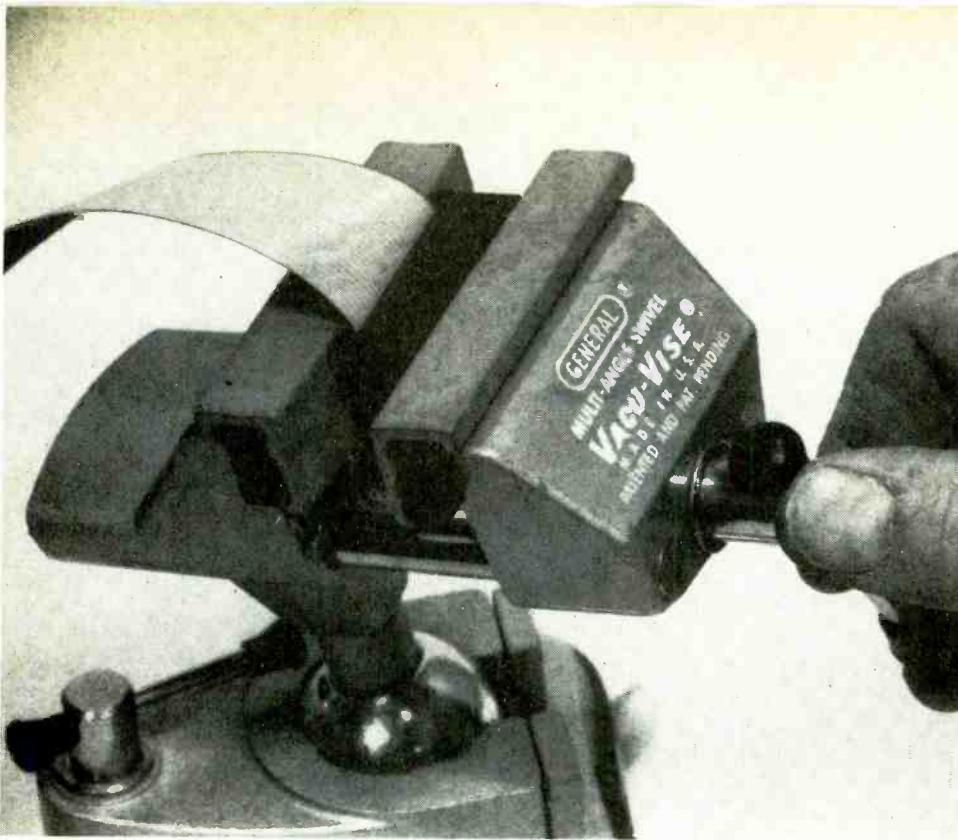

RIBBON connections are simultaneously secured by squeezing the connector—with the ribbon wire in position—between the jaws of a vise. Use only as much pressure as necessary to seat the ribbon completely against the connector—there must be no “daylight” between the ribbon and the connector.

### Is it really standard?

The first step in making your own computer cables is to determine if the things you want to connect together are “standard”—whatever *standard* is supposed to mean. If you’re connecting to a Centronics-type printer, the connections at the printer itself are standard, or at the very least the eight signal lines, the ground, the strobe, the busy, and the *ACK* connections will be standard.

If you’re making up an ordinary RS-232 extension cable, which usually sells for between \$40 and \$60 depending on its length, both ends are usually “standard” unless it’s a *modem cable* which reverses pins 2 and 3 on one end. If there are any peculiar connections, they won’t be in the cable, but rather in

the equipment. For example, if you’re connecting serial I/O (input/output) equipment the ground, TX (transmit), and RX (receive) connections are standard, or TX and RX will be reversed for a modem, but after that anything goes—and usually does. On some RS-232 modem cables the RTS and CTS connections must be reversed for a modem, or completely disabled, or the #20 terminal polarity must be reversed through an outboard integrated circuit serving as an “inverter”. All those things are your problems. But once they’re resolved it’s on to assembling the cables.

### Ribbons are easiest

Quite possibly, the cables for the most of the Radio Shack computers and printers, Heath/Zenith equipment, the

**IF YOU MUST use a solder-type connector, make the connections short-circuit proof. The wires’ insulation should extend right up to the terminal, and a little bit into the terminal if you can manage it. It takes practice. The trick is to have only about 1/8-inch of tinned wire protruding beyond the insulation. Here is where “practice makes perfect,” and patience is a virtue!”**

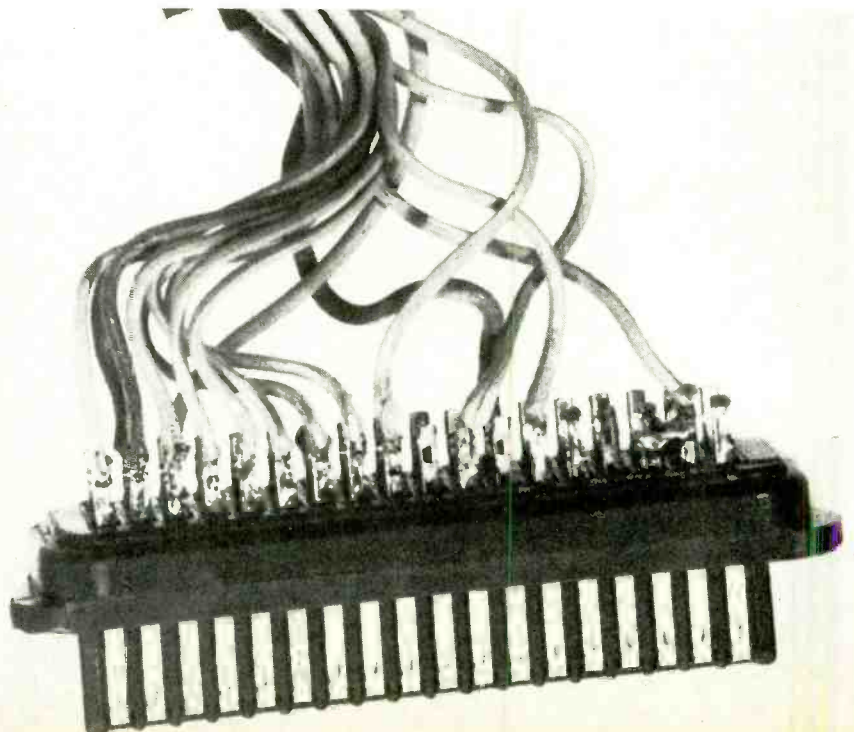

**HERE'S HOW** you handle a cable that can use a ribbon connector on one end (bottom connector) but needs a solder-type connector (top connector) on the other. At the solder-type connector, fold the sides of the ribbon inward to form what is best described as "a flat tube;" then wrap the tube with several turns of plastic tape where it enters the connector's cable clamp. If the cable clamp doesn't bite down hard into the tape, add a few more turns; the wire(s) must be secured by the clamp, not by their soldered terminal connections. Note how the top of the ribbon connector has been labeled to prevent it from being installed the wrong way.

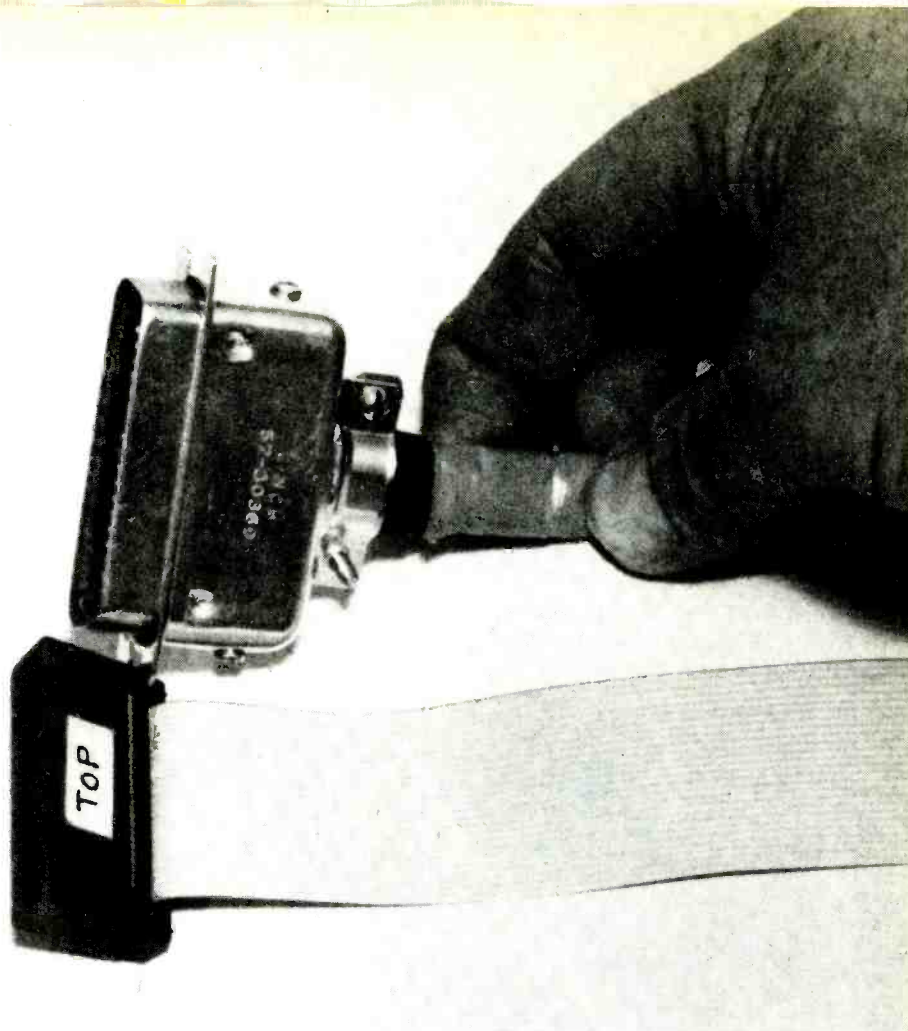

Centronics-type printers, and RS-232 extensions are the easiest to make because the terminal connections were intended for flat ribbon cable; hence, they match on both ends even if the connectors are different. By "match" I mean that the order of the wires is the same even if the connectors and their numbering aren't. For example, if wire #1 on one end is ground, it's ground on the opposite end. If wire #11 is the printer *busy* on one end, it's in the same order on the other end even if the connector terminal isn't #11. Except for the CoCo, Radio Shack computers are a good example of wire standardization; while a Radio Shack computer's parallel-printer output connector isn't necessarily the same as the connector used on the printer, the wires are in order, and to make your own cable—at a savings of at least \$23—you simply crimp connectors conventionally to both ends of a length of ribbon cable and the whole thing works.

In most instances—cables for modems being the exception—ordinary ribbon cable is the best thing to use.

Though connectors for ribbon cable are the easiest to install, they are also the easiest to damage or completely foul up, and you usually don't get two chances with ribbon connectors. Unlike solder-type connectors with some form of channeled terminals, ribbon connectors have nasty little razor-sharp knives euphemistically called "insulation displacement terminals." The connector itself has at least two components, possibly three: the main body, a pressure bar that secures the wires, and possibly an orientation bar that guides the wire out of the connector straight up, straight down, or out the back.

The main body, which is usually a plastic material, has V-shaped, razor-sharp terminals moulded into the body. The ribbon wire is placed on top of the "terminals" and the

plastic bar is placed over the wire. When the bar is squashed down by squeezing the connector in a vise, the wire is forced down on the V-knives. The knives simultaneously pierce the wires' insulation. When the bar is fully seated each wire is sitting at the base of the V-shaped terminal, with plastic insulation between the terminals.

There is no difficulty in assembling a ribbon connector if you take your time. The wire must be trimmed straight across, and a large scissors beats most other kinds of cutter. Then, the wire must be positioned precisely over the terminals and held in place while the bar is positioned and the first pressure is applied. If the wire drifts out of position you can end up with some V-knife terminals cutting through a few wires, a short or two, or some open connections. If possible, just force the bar down by hand to hold it in position, then place the whole connector in a small vise, as shown in the photograph, and close the vise until the bar is completely seated.

It's a lifetime connection, so don't attempt to salvage a used or defective ribbon connector, because it usually won't work. One of the terminals is bound to get bent askew and won't seat around its wire; you'll connect everything together and then spend hours troubleshooting inoperative equipment.

If you're lucky, the other end will take a matching ribbon connector; or if it's a different connector, it will use the exact same wire order. If you're unlucky, which is more than likely, the wires on the other end won't be in the same order. What you must do is use a "cable type" connector which was initially intended for multi-wire *round* cable—the stuff with which we're usually familiar.

Cable-type connectors usually have solder terminals,

though some of the "industrial grade" cable connectors utilize crimp-type connectors that require a special tool that costs between \$100 to \$250. Do not get talked into any kind of sockets using "push in" crimp terminals; you'll cause unbelievable damage if you get one in the wrong connector hole and then try to get it out.

If you must use solder-type terminal connectors on both ends of the wire, your best bet is to use multi-wire *round* cable. But if one end of your cable can be a ribbon connector, then use ribbon cable, and wrap both sides inward where it's to enter the clamp of a solder-type connector. Wrap several turns of plastic tape around the ribbon wire's "fold", pass it through the clamp and shell, and solder to the connector terminals.

Usually, if you must use a solder-type connector, the wiring order will have no relationship to the order on the other end, so double-check each individual wire with an ohmmeter when it's installed. And when you check the latest wire, double-check the connection that precedes it to make certain there's no unseen short circuit. As a rule of thumb, if

# RIBBON CABLE TESTER

ELIMINATE THE TEDIOUS JOB OF RINGING-OUT MULTI-conductor-ribbon or flat cables with the Ribbon Cable Tester. This easy-to-assemble unit finds both shorts and opens in cables—and does it with nothing more fancy than a 6.3-volt transformer, six LEDs, four diodes, and four resistors. Further, all the parts are available from your nearby electronics parts store.

## How it works

The secondary winding of T1 (refer to the diagram) provides a voltage that is rectified by D1, D2, D3, and D4, so that four voltages, +V1, -V1, +V2, and -V2 are produced. The voltages actually provide two pairs of voltages and two independent current loops. Those voltages are wired to one side of a connector, P1, which is attached to the ribbon cable under test. A dummy connector, P2, attaches to the other end of the cable under test so that not one of the four voltages is adjacent to itself in the cable. Thus, by tracing the voltages, shown in four different colors, through the cable and associated connectors, P1 and P2, the following will occur: If all wires in the cable are continuous, LED1 and LED2 will light. And since the voltages V1 and V2 are 180° out of phase, LED1 and LED2 will alternately light at a 60-hertz rate which, to the eye, appears as a steady light.

However, if the wires in one current loop or the other is not continuous, LED1 or LED2 will fail to light, indicating an open loop, as opposed to closed loops. Further, (which may not be obvious), a short between any two adjacent wires in cable under test will form an alternating current path between the two current loops mentioned previously. So, when a short of that nature takes place, one or more of LED3 through LED6 will light.

## Going further

The diagram features a 32-conductor cable assembly, and it might seem that only even-numbered cable assemblies, the most common, can actually be tested using this testing device. However, the procedure can readily be extended to larger or smaller cables, and you can test both even- and odd-numbered cables.

The simplest and most flexible method to test all of the cables mentioned above is use a modular IC breadboard socket or experimenter's PC board, as opposed to actually



**IF YOU FOLLOWED instructions very carefully, used all your basic skills and proceeded with care, your computer cables assembled from the instructions in this article should have a pro-type look.**

your cable has a ribbon connector on one end and a solder connector on the other, install the wires at the solder connector in the order used at the solder connector, starting with the lowest number terminal—#1, or #2, etc. Forget about the other end. You're more likely to get tangled up in the order if you try to follow the order of the ribbon connector when installing soldered wires.

If you're making an RS-232 gender-reverser cable make certain the #1 terminal on each connector is correct. If you have it right, one end will have the #1 to #13 terminals at the top; and when you turn the "reverser" end to end, the other connector will have the #1 to #13 terminals on the bottom.

## Hard to get connectors

As a general rule, Radio Shack stores stock an excellent assortment of ribbon connectors at reasonable prices. However, there are many common connector types they don't have, such as a ribbon or solder Centronics connector, and the 9-pin cable-type connector. Unfortunately, many local electronics parts stores charge up to 50% above list for the *special* connectors. One of the lowest-cost sources for unusual connectors is a data-supply accessories distributor, MISCO, Inc., Box 399-SP, Helmdel, NJ 07733. Write for their catalog. They have such items as Centronics connectors, 9, 25 and even 50 pin D-connectors, and they stock the D-connector hood large enough to accommodate an internal miniature switch for only \$1.85. **SP**



# That new flat ribbon cable may look OK to the eye but hidden shorts and open circuits will put your computer on hold and put you in a straightjacket!

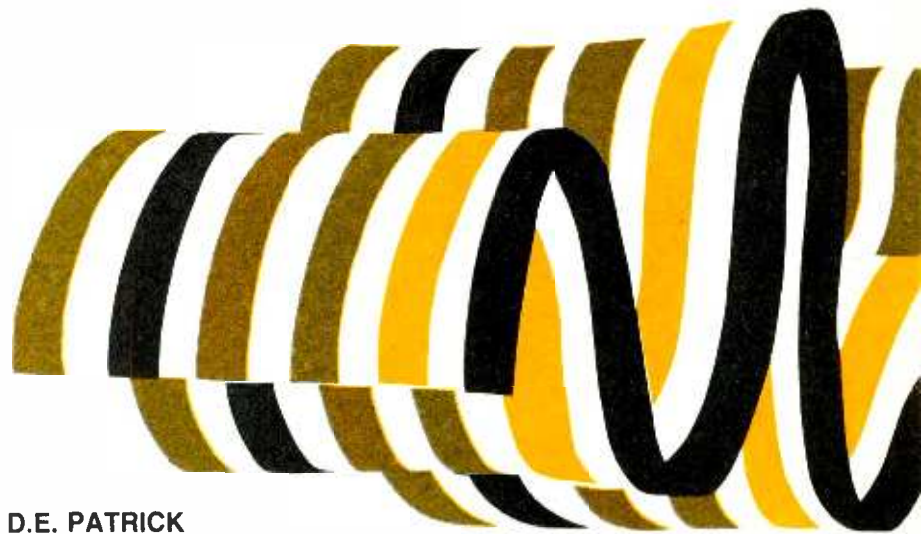

D.E. PATRICK

hardwiring sockets. Then, a wide variety of cable assemblies and types can be tested, allowing quick reconfiguration for various units. And as far as testing odd-numbered conductor cables goes, it's a simple matter to test 48 lines of a 49 wire cable and pull the cables or plugs, shift them over one space or so, and pick up the oddball wire. Further, using that shift procedure, it's possible to test cable assemblies which are larger than your test jig is set up to handle.

## Construction hints

You may use fixed plugs at the ends of the cable assemblies, but that limits flexibility and requires a lot of setup time when testing cables of varying numbers of conductors. Fixed test jigs are recommended only when testing large numbers of cables of the same number of conductors, or if you only have one type to test. A better solution is to use or adopt breadboard socket strips or experimenter strips designed for that purpose, where it's a simple matter to set up for most commonly used cables in a few minutes, by sticking in a few jumpers.

The configuration of the actual test jig for the Ribbon Cable Tester to suit your particular purposes may require some ingenuity. But, try to keep things uncomplicated for best results. Some useful options, such as colored LEDs might be added.

OK—we have got you thinking now, so go ahead and design your own test setup. We did not include a Parts List with the Ribbon Cable Tester project because you should adapt and design to your testing needs. One tip: Prepare dummy plug P2 for installation at remote cable-end locations. In our editorial office we have 40-wire ribbon cables snaked throughout the office interconnecting many rooms. Thus, the cable installation may remain unaltered with the test hookup made possible by a two-part test unit. **SP**

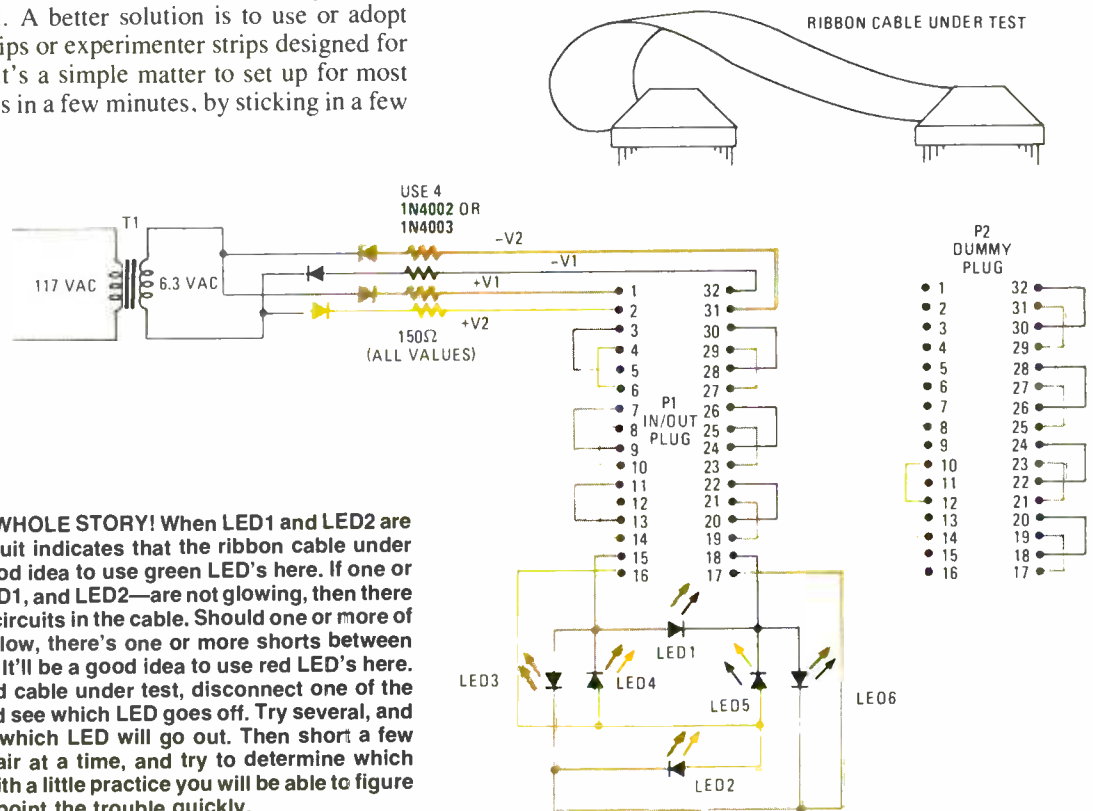

**THE LED'S TELL THE WHOLE STORY!** When LED1 and LED2 are both glowing, the circuit indicates that the ribbon cable under test is OK. It'll be a good idea to use green LED's here. If one or both green LED's—LED1, and LED2—are not glowing, then there are one or more open circuits in the cable. Should one or more of LED3 through LED6 glow, there's one or more shorts between the wires in the cable. It'll be a good idea to use red LED's here. Once you have a good cable under test, disconnect one of the wires in the test jig and see which LED goes off. Try several, and attempt to determine which LED will go out. Then short a few pairs together, one pair at a time, and try to determine which LED's will come on. With a little practice you will be able to figure out the logic, and pinpoint the trouble quickly.



# MoCo Preamplifier

**Super matched pair of low-noise transistors provides the needed audio boost for your super-fi, moving-coil phono cartridge**

RON DE JONG

BY FAR THE MOST COMMON CARTRIDGE CURRENTLY IN USE IS the moving-magnet cartridge. In that design, a tiny magnet is mounted on the remote end of the cantilever and provides a magnetic field cut by two fixed coils mounted close by. When the magnet is set in motion, as occurs when the stylus tracks the record groove, the magnetic field moves and small electrical signals are generated by the two coils. Those signals are subsequently fed to a phono preamplifier and to the tone control and power amplifier stages.

Over the last few years, however, there has been renewed interest in another type of cartridge—the moving coil cartridge. Some dedicated hi-fi enthusiasts claim that the moving coil cartridge offers advantages in terms of transient response, frequency response, and phase response at high frequencies. Whether or not those claims are valid is a matter for some argument—suffice to say that we do not intend to enter the debate here.

So how does a moving-coil cartridge differ from a moving-magnet type? The answer is that the positions of the coils and magnets are reversed, although the principle of operation remains essentially the same.

In the moving-coil cartridge, the magnet is held stationary while two miniature coils are mounted on the cantilever assembly and move as the stylus tracks the groove (hence the name “moving coil”). Since the coils are attached to the cantilever, they must be kept extremely small to keep the tip mass to a minimum. As a result, the output level of a moving-coil cartridge is extremely low, typically around 200  $\mu$ V. That is around 27 dB below the output level of a moving-magnet cartridge, which is typically around 5 mV, or more.

Because the output of a moving-coil cartridge is so low, considerable voltage gain is required before the signal is fed

into the phono inputs of a conventional hi-fi amplifier. One solution is to use a transformer, but those are quite expensive and difficult to manufacture. The alternative solution is to use an additional preamplifier stage; and the design presented here has performance equal to or better than most commercial units for a fraction of the cost. We call it the MoCo Preamplifier for obvious reasons.

Before taking a look at the circuit, however, it may be as well to point out that the requirement for a separate preamplifier is one reason why moving-coil cartridges have not gained widespread popularity in the past. Commercial units tend to be expensive and that, coupled with the high cost of the cartridge itself (\$100 or more), has been sufficient to deter most hi-fi enthusiasts. This project will help overcome that problem, as far as the cost of the preamplifier is concerned!

## Design considerations

Perhaps the most important specification of a MoCo Preamplifier is the signal-to-noise ratio. Let's first take a look at the various sources of noise and find out how they may be minimized in a low-noise preamplifier design.

There are four main sources of noise in a transistor amplifier: shot noise, emitter-base voltage noise,  $1/f$  noise, and thermal noise. Those individual noise sources are illustrated in Fig. 1, which shows a simplified model of a noisy transistor amplifier. Note that we only show noise generators at the input of the amplifier and not noise generated in later stages. In most cases that is quite valid, because the amplifier is most sensitive at the inputs and following stages will operate at higher signal levels.

Looking at each noise source individually: “Shot noise” or quantum noise occurs because of the discrete nature of electric current, which is actually pockets of individual electrons comprising the current flow and not a homogenous flow like water from a tap. The mechanism involved is analogous

*continued on page 38*

Original project appeared in *Electronics Australia*, August, 1981 Edition, and reappears here by permission.

# Everybody's making money selling microcomputers. Somebody's going to make money servicing them.

## Now NRI Trains You At Home To Make Money Servicing, Repairing, and Programming Personal and Small Business Computers

Seems like every time you turn around, somebody comes along with a new computer for home or business use. And what's made it all possible is the amazing microprocessor, the tiny little chip that's a computer in itself.

Using this new technology, the industry is offering compact, affordable computers that handle things like payrolls, billing, inventory, and other jobs for business of every size . . . perform household functions including budgeting, environmental systems control, indexing recipes. And thousands of hobbyists are already owners, experimenting and developing their own programs.

## Growing Demand for Computer Technicians

This is only one of the growth factors influencing the increasing opportunities for qualified computer technicians. The U.S. Department of Labor projects over a 100% increase in job openings for the decade through 1985. Most of them *new* jobs created by the expanding world of the computer.

## Learn At Home to Service Any Computer

NRI can train you for this exciting, rewarding field. Train you at home to service not only microcomputers, but word processors and data terminals, too. Train you at your convenience, with clearly written "bite-size" lessons that you do evenings or weekends, without going to classes or quitting your present job.

Your training is built around the latest model of the world's most popular computer. It's the amazing TRS-80™ Model III now with disk drive and the capabilities and features to perform a host of personal and business functions. No other small computer has so much software available for it, no other is used and relied on by so many people. And it's yours to keep for personal and business use.

You get plenty of practical experience. Under NRI's carefully planned training, you even install a *disk drive* verifying at each step its operation. Using the NRI Discovery

(TRS-80 is a trademark of the Radio Shack division of Tandy Corp.)

Lab® that also comes as part of your course, you build and study circuits ranging from the simplest to the most advanced. You analyze and troubleshoot using the professional 4-function LCD digital multimeter you keep to use later in your work. Then you use the lab and meter to actually access the interior of your computer . . . build special circuits and write programs to control them. You "see" your computer at work and demonstrate its power.

## Same Training Available With Color Computer

NRI offers you the opportunity to train with the TRS-80 Color Computer as an alternative to the Model III. The same technique for getting inside is enhanced by using the new NRI-developed Computer Access Card. Only NRI offers you a choice to fit your specific training needs.

## Become the Complete Computer Person

In addition to training in BASIC and advanced machine language, you gain hands-on experience in the operation and application of the latest computers



for both business and personal jobs. You're trained to become the fully rounded, new breed of technician who can interface with the operational, programming, and service facets of all of today's computers. You're ready to take your place in the new electronic age.

## Other Opportunities

NRI has been giving ambitious people new electronic skills since 1914. Today's offerings also include TV/Audio/Video Systems servicing with training on our exclusive Heath/Zenith computer-programmable 25" diagonal color TV . . . Industrial Electronics, Design Technology . . . and other state-of-the-art courses.

## Free Catalog . . . Mail Card Today

Send the postage-paid card for our 104-page catalog showing all courses with equipment and complete lesson plans. There's no obligation other than to yourself. See how NRI can help you take advantage of the exciting job and earnings opportunities in the exploding field of microcomputers. If card has been removed, please write to us.

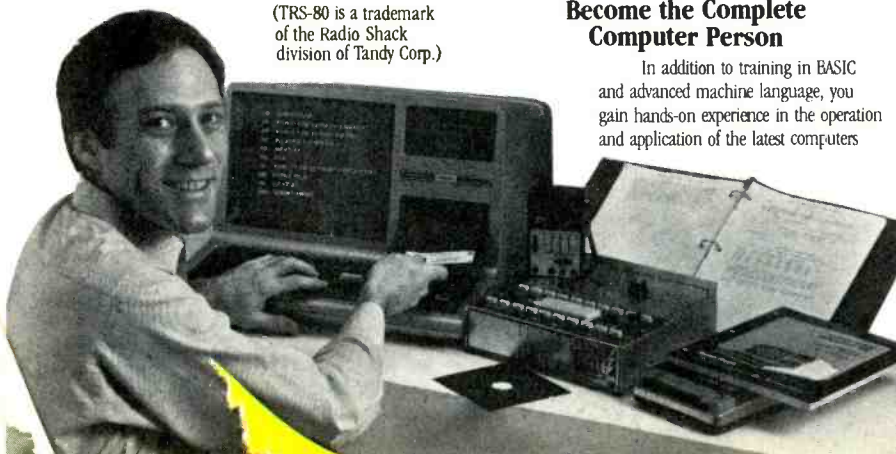

**NRI Schools**  
McGraw-Hill Continuing  
Education Center  
3939 Wisconsin Ave.  
Washington, DC 20016

**We'll give you tomorrow.**

continued from page 34

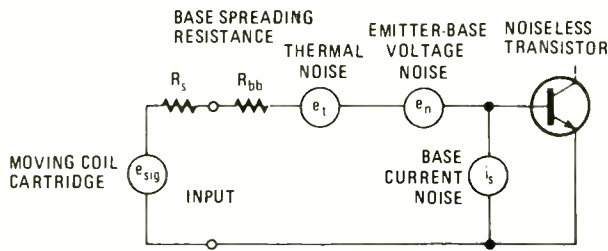

**FIG. 1—SIMPLIFIED MODEL of a noisy transistor amplifier. The noise-generating elements from the transistor which actually cannot exist. The text provides detailed circuit description.**

to rainfall in that individual raindrops striking a tin roof create noise. From that, you can see that shot noise actually increases with collector current. Another feature of shot noise is that it is "white" in character, that is the noise amplitude is constant with frequency.

Referred to the input of the transistor, the shot noise is called *base-current noise* and is modelled by a current generator at the input (see Fig. 1).

*Emitter-base voltage noise* is modelled by a voltage source in series with the base. That is also a white-noise source but, unlike base-current noise, actually decreases with increasing collector current.

*1/f or flicker noise* is a significant source of noise at low frequencies because, as its name suggests, it has  $1/f$  spectral characteristic and thus noise voltage increases as the inverse of the frequency.

The best-known source of noise is probably the *thermal* or *Johnson noise* generated in a resistor. That also has a white-noise distribution. We can minimize that source of noise by minimizing the input resistance, and that has the added benefit of reducing input-noise voltage due to base-noise current.

Referring to Fig. 1, we can see that the input resistance consists of the source resistance and the "base-spreading resistance" of the input transistor. The source resistance ( $R_s$ ) is the resistance of the moving-coil cartridge, while the base-spreading ( $R_{bb}$ ) resistance is an inherent feature of the transistor.

**GUTS-EYE VIEW** of the MoCo preamplifier illustrates how neat and clean this project can be assembled. Batteries take up the bulk of the volume in the cabinet. Should you prefer a 12-volt regulated supply, the outside case can be greatly reduced. Use shielded cables for input and output leads to and from the printed circuit board. Use a wall-plug/battery supply to feed the regulator circuit.

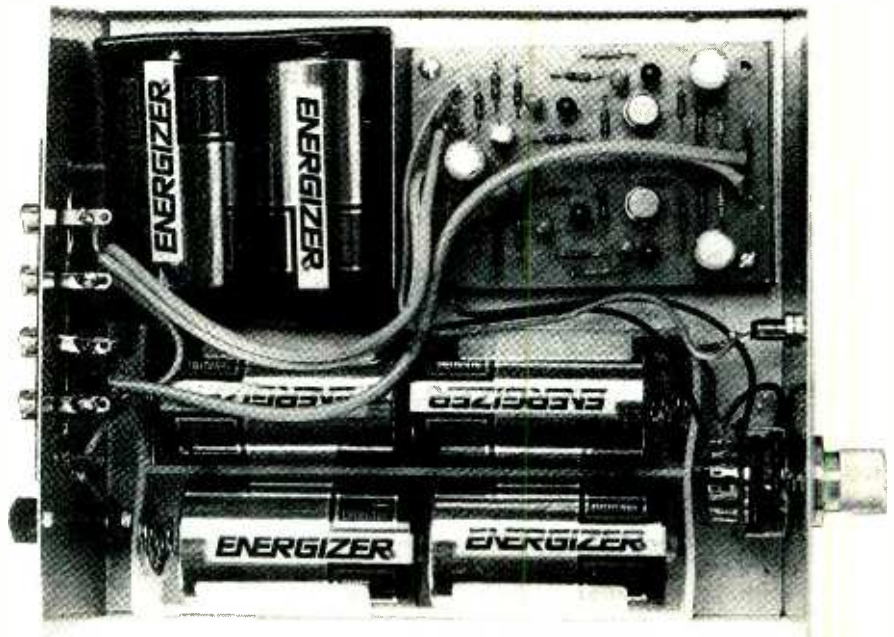

Clearly, we can significantly reduce thermal noise by choosing a transistor with a very low  $R_{bb}$ —or base-spreading resistance. Most audio transistors have an  $R_{bb}$  of around 100, while for some UHF transistors it can be as low as 4. In fact, some designs for moving-coil preamps *do* use UHF transistors. We can also achieve low  $R_{bb}$ , however, by simply connecting a large number of transistors in parallel, thus dividing  $R_{bb}$  by the number of transistors used.

The approach we eventually took was to use an LM394 super-matched transistor pair. Each of those transistors actually consists of a large number of individual transistors connected in parallel, giving each device an  $R_{bb}$  of 40 or 20 when the two are connected together. Those transistors also have very high  $H_{fe}$  of 500 and, due to the large number of transistors, statistical variations are considerably reduced; thus  $1/f$  noise is very low.

What has emerged so far is that we can minimize noise by reducing the input resistance; but so far we have not considered how to minimize the effect of base-current noise and emitter-base voltage noise. Since one increases with collector current while the other decreases, there is an optimum collector current at which the overall noise is at a minimum. To work that out we have to sum all the noise sources into an *equivalent input-noise voltage*.

Since the various sources are statistically unrelated, we do not simply add the voltages together but take the square root of the sum of the squares. Differentiating that equation with respect to collector current reveals that the minimum noise can be calculated, and suggest suitable design considerations.

### The circuit

Let's now take a look at the actual circuit we have used. See Fig. 2. The basic configuration is one we have taken from the National Semiconductor Linear Applications Handbook and uses just four transistors. Briefly, Q1 and Q2 are connected in parallel as a common-emitter amplifier, with Q3 as a constant current load. That drives Q4, another common-emitter amplifier, which in turn drives the output and the feedback network to Q1 and Q2.

Looking at the circuit in more detail now, we have included a small RF choke, RFC1, at each input (you need two for stereo). It consists of four turns of No. 28 wire on an

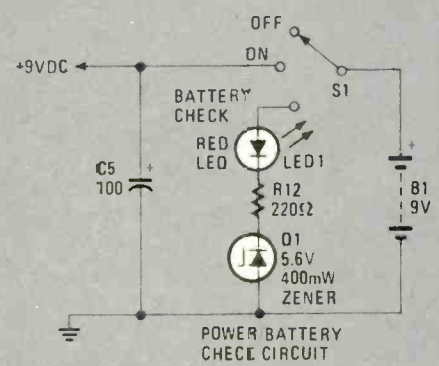
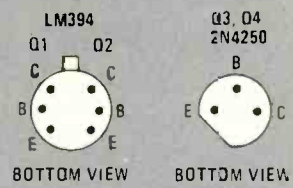
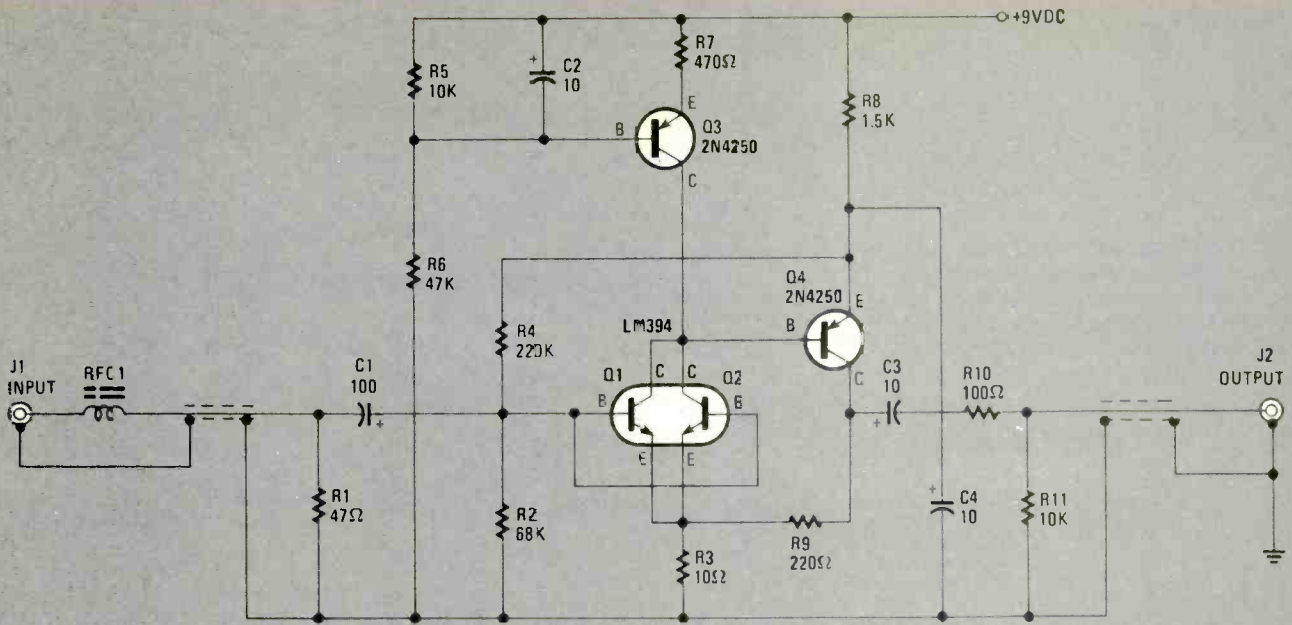

FIG. 2—ONE CHANNEL of the necessary two channels for the stereo amplification of a moving-coil stereo cartridge. Each audio channel, except for the common power supply and phono cartridge, is electrically apart and independent. Transistors Q1 and Q2 are physically located in one metal top-hat can, and appears as a single transistor in the unit should you not spot the six leads coming from the base.

**PARTS LIST FOR MOCO PREAMP**  
(Note: double quantity for stereo)

**SEMICONDUCTORS**

Q1, Q2—LM394—Super-matched pair NPN transistor  
Q3, Q4—2N4250 or A5T4250 low-level, low-noise silicon transistor

**RESISTORS**

All resistors are 1/4-watt, 5% fixed composition type  
R1—47-ohm  
R2—68,000-ohm  
R3—10-ohm  
R4—220,000-ohm  
R5, R11—10,000-ohm  
R6—47,000-ohm  
R7—470-ohm  
R8—1500-ohm  
R9—220-ohm

**CAPACITORS**

All capacitors are 16-WVDC, electrolytic type  
C1—100-μF

C2-C4—10-μF

**ADDITIONAL PARTS AND MATERIALS**

J1, J2—Phono jack, RCA type  
RFC1—4 turns of #28 wire on Phillips FX1115 ferrite bead  
Metal case, printed circuit materials, hardware, wire, solder, etc.

**PARTS LIST FOR BATTERY POWER SUPPLY**

B1—6 1.5-VDC D cells connected in series  
C5—100-μF, 16-WVDC electrolytic capacitor  
Z1—5.6-V, 400-mW Zener diode  
LED1—Light emitting diode, red diffused lens  
S1—Single-pole, 3-position toggle switch (center off); one throw position may be spring-return to off  
R12—200-ohm, 1/4-watt, 5% resistor  
Battery holders for D cells, wire, hardware, etc.

FX1115 bead and in conjunction with the 47-ohm resistor, R1, following, prevents RF interference from being rectified by the input stage and passed to the amplifier Q4. A 100-μF electrolytic capacitor, C1, couples the input signal to transistors Q1 and Q2.

Because of feedback to the emitters of Q1 and Q2, the input impedance of the stage is quite high at around 35,000-

ohms. The recommended load for most moving coil cartridges is merely stated as being greater than 10-ohms but if it is too high the leakage inductance of the cartridge will create unwanted bass boost. It is for that reason that we have included the 47-ohm resistor, R1, on the input. Incidentally, that resistance is the standard input impedance of most moving coil preamplifiers.

FIG. 3—FOIL-SIDE PATTERN of the printed-circuit board used to assemble the MoCo Preamplifier. Physical isolation of the left and right audio stereo circuits greatly reduces possibility of crosstalk.

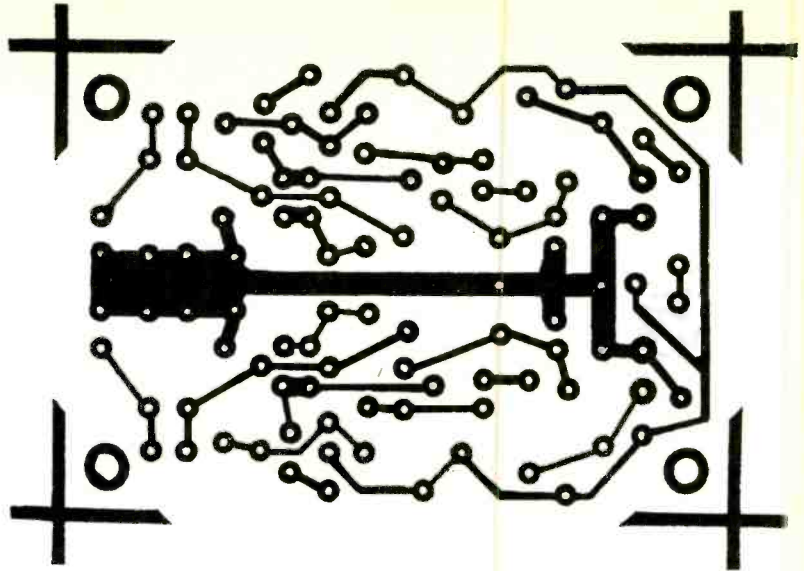

The collector load of Q1/Q2 is transistor Q3, used here as a constant-current source delivering about 3 mA. We have used it in preference to a simple resistive load because it permits us to adjust the collector current of Q1/Q2 independently of gain. In addition, it increases the open-loop gain and linearity of the amplifier to give very low distortion figures, and increases the supply rejection ration (important if the unit is to be run from a plug pack).

Following Q1 and Q2 we have another common-emitter amplifier consisting of transistor Q4. The emitter is decoupled to ground rather than to the supply, which again improves the supply rejection, and the emitter voltage is used to bias Q1 and Q2 on. The arrangement is a variation on collector biasing, because the emitter voltage of Q4 tracks the collector voltage of Q1 and Q2. However, it has an advantage over conventional collector biasing in that there is no loading effect.

Collector load of Q4 is a 220-ohm resistor, R9, which forms part of a voltage-divider feedback circuit with the 10-ohm emitter resistor, R3, of Q1/Q2. The voltage-divider ratio sets the closed loop gain at 23 (or about 27 dB) which is the gain required to bring moving-coil cartridge output levels up to normal phono-input levels.

Output from the MoCo Preamplifier is AC-coupled via a 10- $\mu$ F tantalum capacitor, C3, and a 100-ohm resistor, R10, with a 10,000-ohm pulldown resistor, R11, after the capacitor to remove any DC voltage on the output. The purpose of the 100-ohm resistor is to isolate the feedback loop from any loading effects of the following amplifier or shielded cable. If that is not done, any capacitive loading will introduce an additional phase lag which could make the MoCo Preamplifier unstable.

The computed equivalent input-noise voltage is 98 nV. That gives a S/N ratio of 64 dB with respect to a 150  $\mu$ V input

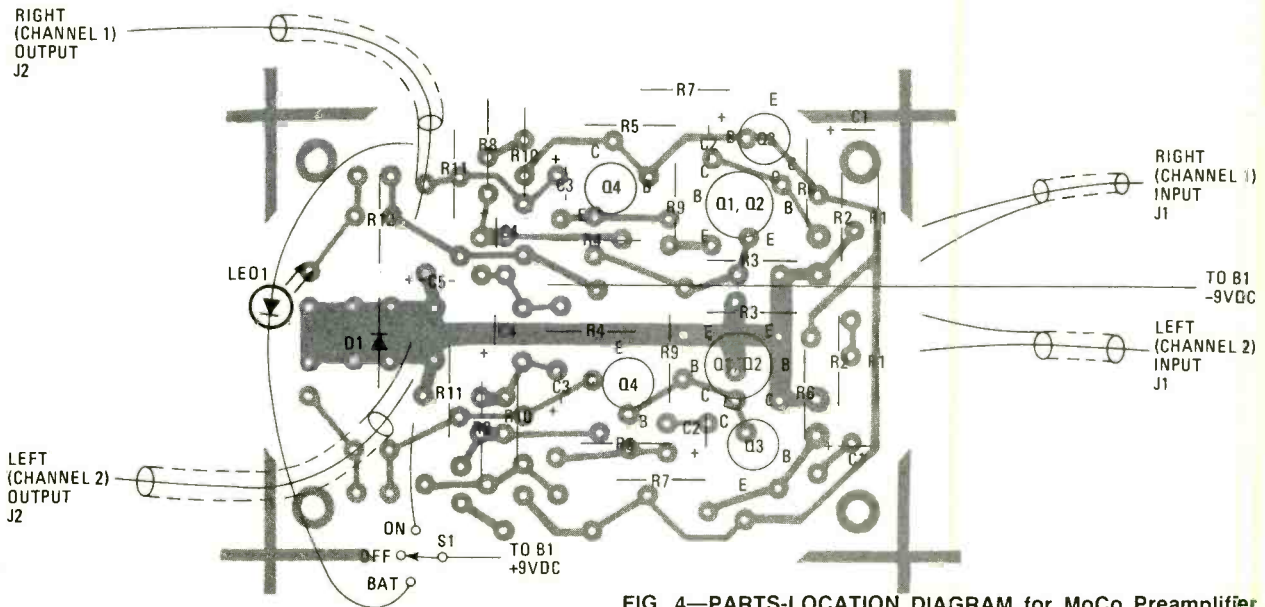
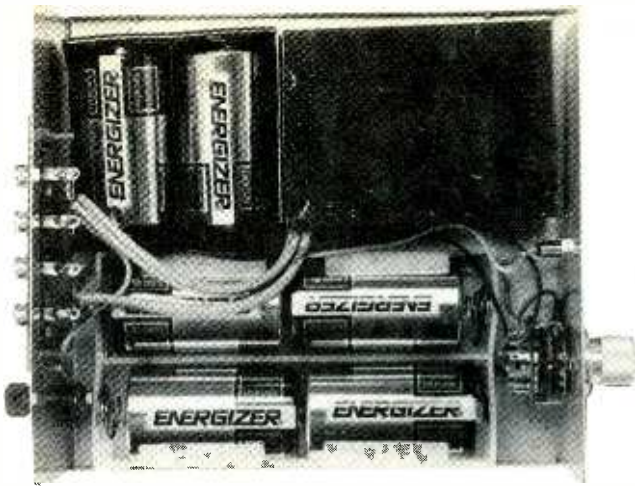

FIG. 4—PARTS-LOCATION DIAGRAM for MoCo Preamplifier shows how simple the project really is. Note that there are many parts designations that are repeated because both audio circuits use the same parts-symbol designation technique. Those parts not duplicated on the printed-circuit board relate to the power supply/battery-check circuit in Fig. 2.



**THIS INSIDE VIEW** is slightly different from the other photo because of the addition of a metallic shield within the metal case. The added shielding will greatly reduce noise pickup, a common fault with many low-level, high-gain preamplifiers.

signal. This was exactly the measured result on the finished prototype.

One point which also emerges is that the base-noise current is well below the other noise sources. Hence, we could have increased the collector current of Q1/Q2 and thus reduced the emitter-base voltage noise considerably. If we use the formula for optimum collector current for lowest noise we find that the current is around 20 mA which is much greater than the 3 mA we chose. We did that for two reasons however: lower distortion and lower power consumption.

Power for the unit is obtained from six 1.5-volt "D" size batteries (See Fig. 2).

A battery check function is provided consisting of a front-panel light-emitting diode, LED1, 220-ohm resistor, R12, and 5.6-V Zener diode, D1. When the front panel switch, S1, is set to BATTERY CHECK, power is applied to the circuit. If the battery voltage exceeds the 5.6-V drop across the Zener and the 1.6-V drop across LED1 (7.2 VDC) then LED1 will turn on. If LED1 glows very feebly or not at all, a new battery is required.

## Construction

Construction of the unit is straightforward. Most of the components are mounted on a single printed-circuit board (Fig. 3 and 4).

The author's unit was built into a standard metal case measuring  $7\frac{1}{4} \times 2\frac{3}{4} \times 6\frac{1}{8}$  inches (D  $\times$  H  $\times$  W). The unit comes with a U-shaped steel cover and an aluminum base and, because the case is not all steel, trouble with hum fields from nearby power transformers may be experienced in some instances. Our solution was to mount the MoCo Preamp board inside a separate, small galvanised (more commonly referred to as galvanised iron) steel box. That gives excellent results and, because it is inside the main case, does not detract from the appearance of the unit. You will have to fabricate the steel box yourself if you cannot find some suitable steel box.

The PC board is mounted inside the box using four  $\frac{3}{8}$  to  $\frac{1}{2}$ -in tapped brass spacers. Before mounting the PC board, however, make a cutout on the back panel for the 4-way RCA connector and drill holes and the back-panel earthing terminal and the front-panel switch and LED bezel.

The back-panel ground terminal must be connected to ground lug and there to the ground terminal on one of the output sockets. The RF chokes at the inputs are made by passing four turns of No. 28 enameled copper wire through a small ferrite bead, type FX1115 from Philips. One end of each choke is soldered to an RCA input terminal and the other end to the inner conductor at the shielded cable. The outputs from the MoCo Preamplifier are also connected via shielded cable.

If you are using batteries to power your unit, then you will require one  $4 \times$  "D" cell battery holder and one  $2 \times$  "D" cell battery holder. They are wired up in series to give the requisite 9 VDC. Alternatively, a plug-pack power supply and the regulator board can be used.

Finally, check all wiring carefully and then switch to the "battery-check" position. The front-panel LED should come on to indicate that battery voltage is present. Now switch to the ON position and check the preamplifier for correct operation, simply by connecting it to a moving-coil cartridge and amplifier and trying it out. Happy listening! **SP**

## ADDING A REGULATED SUPPLY

You may decide to power the MoCo Preamplifier with a regulated DC power supply to avoid the replacement of D cells from time to time. The suggested technique is to use an external 9-volt DC plug pack (a 12-volt unit will do) and then regulate the voltage to 9-volts. It can be done because the plug packs produce voltage as high as 20-volts DC with no load or very little load as is the case with the MoCo Preamplifier.

Use whatever regulated power supply you wish. The LM317 IC chip can do the job. Do not mount the plug pack inside the preamplifier case, or keep it close to the case, because the internal transformer will introduce considerable AC hum. With the batteries and holders removed, there is more than enough room in the chassis box. Regulated power supply circuits are easy to come by—just flip the pages of this issue.

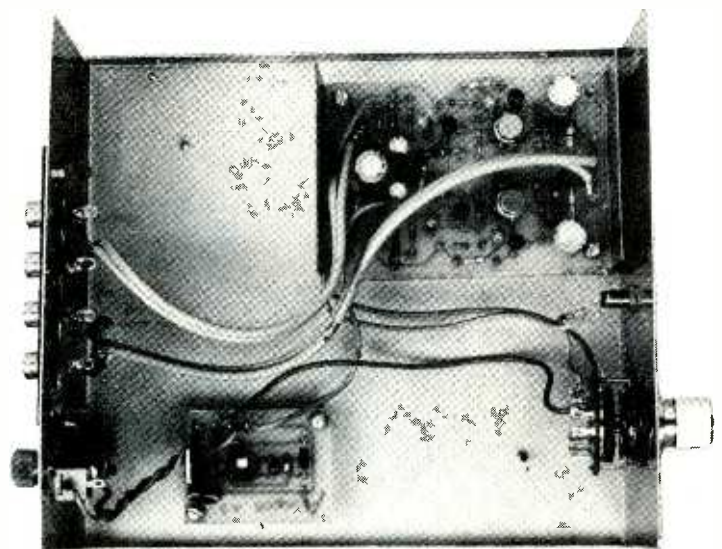

# SINGLE SWEEPER ONE



MANY SINGLE-SWEEP, BLANKING CIRCUITS HAVE BEEN PROPOSED as add-on options to oscilloscopes like older Dumonts and the Philips PM3210, which have external sweep-ramp or gate outputs and Z-axis inputs. (Fig. 1). However, none match the performance of the built-in circuits they are attempting to mimic, based on disabling sweep or trigger circuits after one sweep in Fig. 2.

Most add-on designs unblank the scope's CRT for one-sweep cycle via its Z-axis or intensity-modulation input after a reset or new sweep command, then blank the CRT again by

triggering off the trailing edge of a sweep-ramp or gate output (Fig. 1). But, most add-on designs have partial display, asynchronous reset, and lock-out problems. Further, little effort has been made to apply those circuits to scopes like the Tektronix T921/T922 or Heathkit IO-4510; the former has a Z-axis input, but no external-ramp or gate output, and the latter has neither external-sweep output nor Z-axis input.

## Taking a closer look

With the typical marginal, sweep-blanking circuit in Fig. 1, the oscilloscope's CRT is held blanked via its Z-axis by the flip-flop's Q or  $\bar{Q}$  outputs. Depressing the RESET switch sets the flip-flop and unblanks the scope's CRT. After a one-sweep cycle, the negative trailing edge of the sweep-ramp or sweep-gate fires the one-shot, which resets the flip-flop via its clock input, with J tied low. The flip-flop holds the scope's CRT blanked once again until the next manual reset. However,

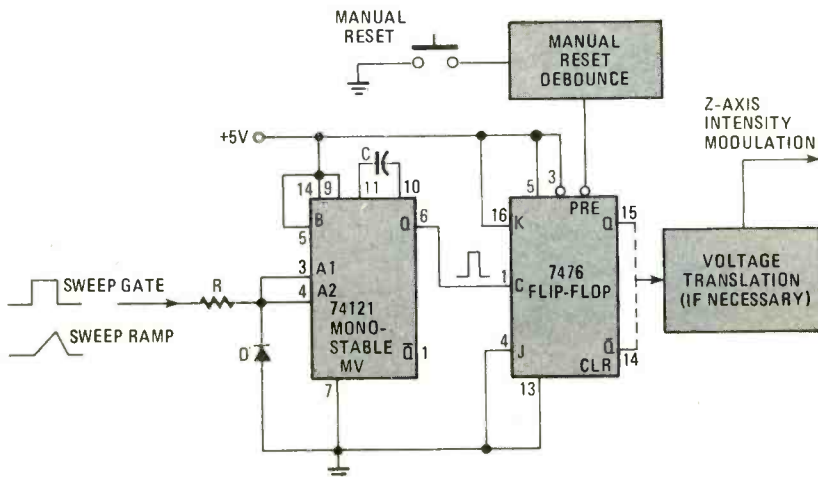
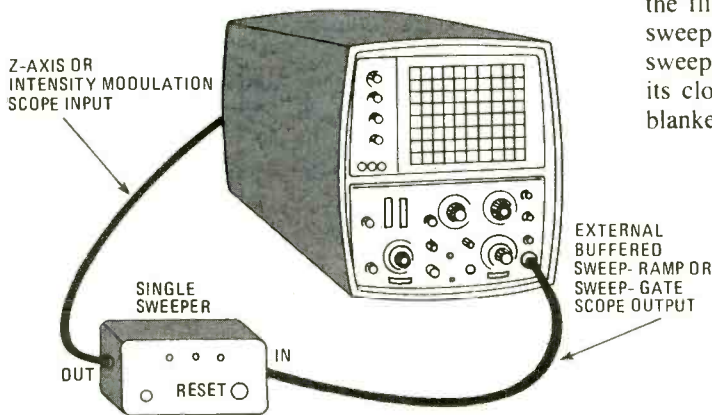

FIG. 1—MOST MARGINAL single-sweep blanking designs are based on scopes with an external-buffered, sweep gate or ramp outputs and Z-axis. In the drawing at left, the scope's CRT is held blanked via its Z-axis by the flip-flop's Q or  $\bar{Q}$  outputs. Depressing the RESET sets the flip-flop and unblanks the scope's CRT. After one sweep cycle, the negative trailing edge of sweep ramp or sweep gate fires the one-shot flip-flop, which resets the flip-flop via its clock input, with J tied low. The flip-flop holds the scope's CRT blanked once again until the next RESET. However, that scheme works when the scope's ramp generator is being triggered *only occasionally*; otherwise, the asynchronous reset causes partial display and lock problems. This design cannot be used with free-running synced scopes, and it's sensitive to ramp or gate rates.



# Here's a sweet-acting single-sweep, blanking circuit packaged to cope with the limitations of your old, but still serviceable oscilloscope!

D.E PATRICK

that (and similar circuits which have appeared in the literature) works when the scope's ramp generator is being triggered *only occasionally*; otherwise, the asynchronous manual reset causes partial display and lock-out problems. That design, and similar ones, cannot be used with free-running synced scopes; it is sensitive to ramp or gate rates, and generally isn't worth the time to build.

On the other hand, single-sweep disable circuits built into a scope, as in Fig. 2, operate on the principle of disabling trigger or sweep circuits, as opposed to blanking the CRT. They also cannot be used with free-running, untriggered scopes; and since the trigger and sweep circuits of every oscilloscope are quite different, trying to build a general-purpose circuit would be next to impossible. Further, on some scopes, where major modifications to existing circuits would be necessary, the implementation of such a circuit would be too advanced a job for a neophyte.

In any case, in Fig. 2, when the momentary manual RESET switch S1 is pushed and released, IC1-a sets and resets, providing a debounced pulse output at  $\bar{Q}$  (pin 6) and Q (pin 5), where either may be used as the clock input to IC1-b at pin 11. The former case assures that the manual RESET switch S1 must be pressed and released for the action to take place. In the latter case, IC1-b gets set as soon as the manual RESET switch is pressed, which is similar to the configuration used in the Tektronix T922R. (The T922R is the rack-mount

version of the T922, but unlike the T922, it has external ramp, gate, and a single-sweep option.)

Now, in Fig. 3 we can see that IC1-b sets on the positive edge of IC1-a's  $\bar{Q}$  output, at time t1. At time t2 the oscilloscope's trigger circuit produces a pulse, which in turn causes the sweep gate to go low. (The bar symbol indicates an active low signal.) Sweep gate going low resets IC1-b, and the scope's sweep cycle begins. However, when IC1-b gets reset, the scope's trigger circuits are disabled. Therefore, after the completion of one sweep cycle, there won't be another sweep displayed until the manual RESET or sweep command switch S1 is depressed again, because the trigger circuit itself cannot retrigger the sweep circuit.

Obviously, the difference between Fig. 2 and 1B is the fact that the former is inherently "synced-up" and asynchronous reset is an impossibility. However, the partial, single-sweep disable circuit's (Fig. 2) deceptive simplicity belies the fact that it cannot be generally applied.

## One that really works

In order for a single-sweep, blanking circuit to be as effective as a single-sweep, disable circuit, the former must sync-up the unblanking of the scope's CRT with the start of a sweep cycle. Only one complete sweep cycle, with each RESET or new sweep command request must be allowed. Partial displays and lock-out conditions must be eliminated.

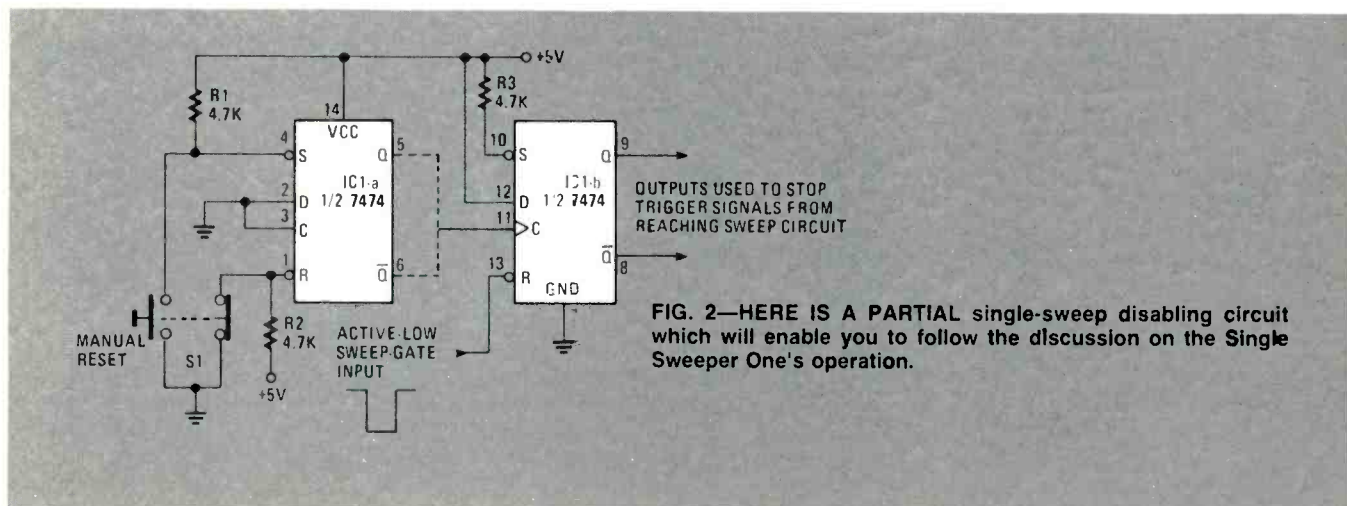

FIG. 2—HERE IS A PARTIAL single-sweep disabling circuit which will enable you to follow the discussion on the Single Sweeper One's operation.

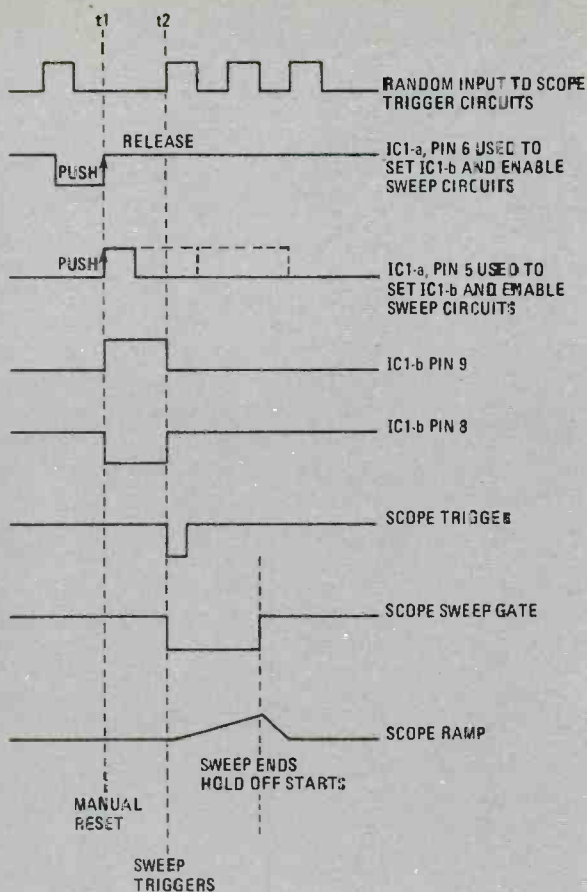
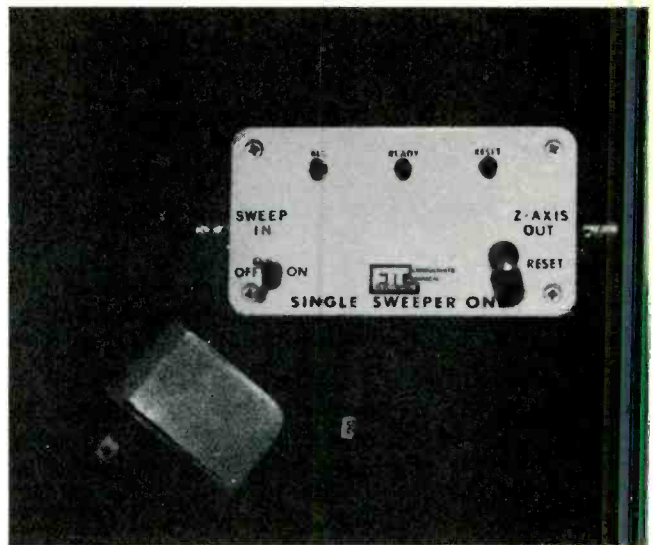

FIG. 3—TIMING DIAGRAM for the circuit action on Fig. 2. Time advances are from left to right.

And, the circuit must be relatively insensitive to ramp, or gate, repetition rates.

### Overview

Fig. 4 is the circuit of the basic Single Sweeper One. It accomplishes all the above by debouncing the reset or sweep-command signal from IC1-a. It stores the command in IC1-b when the RESET switch S1 is released or an external pulsed reset command is applied to IC1-b's set input. IC2-b syncs up the reset command and the leading edge of sweep gate or



THIS VARIATION of the Single Sweeper One uses a built-in 5-volt regulator supply. Raw DC voltage is supplied from a plug-in, modular 12-volt DC supply borrowed from an old cassette portable. Select jack to match plug on supply's cable end.

similarly derived pulse, indicating the start of a scope's sweep cycle, unblanking the scope's CRT. IC2-a resets the single-sweep, blanking-control flip-flop (IC2-b), blanking the scope's CRT again on the trailing edge of sweep gate, which indicates that one sweep cycle has been completed. When IC2-b unblanks the scope's CRT, it simultaneously resets IC1-b, in which the reset command was stored, and when IC2-b begins to blank the CRT again, it simultaneously resets IC2-a, the flip-flop that reset it.

Therefore, at the completion of the above cycle of events, the scope's CRT will remain blanked until either the RESET button S1 is depressed and released, or a pulsed reset-command signal initiates another cycle.

### Operation

Now, that was a little quick; let's do it again, *by the numbers* this time. See Fig. 4. When the momentary RESET switch S1 is pushed and released, IC1-a sets and resets, providing a debounced pulse output at Q (pin 6). On the positive-going edge at pin 6, which coincides with the release of S1, IC1-b will be set by its clock input (pin 11) going high, with its D input (pin 12) tied high. IC1-b stores or holds the

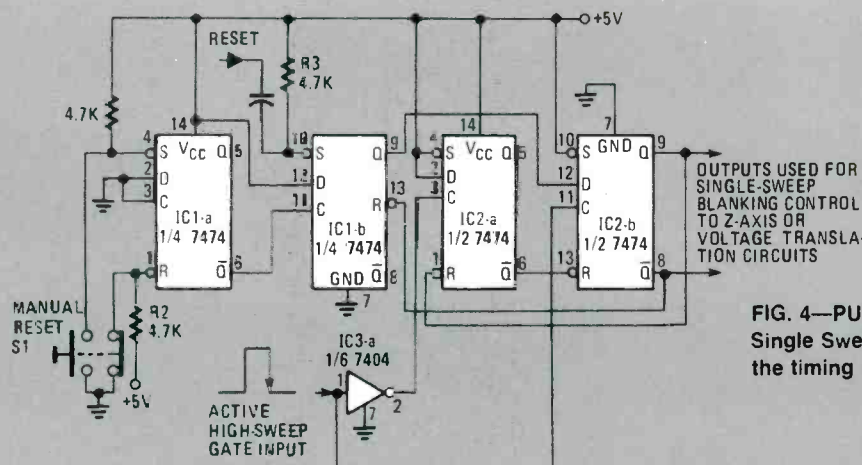

FIG. 4—PUT IT ALL TOGETHER, it spells Single Sweeper One—the timing heart of the unit.

## PARTS LIST FOR SINGLE SWEEPER ONE

### SEMICONDUCTORS

IC1, IC2—7474 dual D edge-triggered flip-flop integrated circuit  
IC3—7404 hex inverter integrated circuit  
\*IC4—7805 5-volt regulator integrated circuit  
LED1-LED3—Light emitting diode with red diffused lens  
+ Q1—2N2222 or 2N3904 NPN transistor  
+ Q2—2N2907 or 2N3406 PNP transistor

### RESISTORS

All resistors are fixed composition, 1/4-watt, 5% components

R1, R2, R3—4700-ohm  
R4—100,000-ohm (this value is suitable for sweep gate or ramp voltage levels of 30-volt approximately. Use 1-Megohm value for higher values.)  
+ R5—1000-ohm  
+ R6—470-ohm  
R7-R9—470-ohm

### CAPACITORS

\*C1—100- $\mu$ F, electrolytic 10-WVDC  
\*C2—.1- $\mu$ F disc  
\*C3—.04- $\mu$ F disc

### ADDITIONAL PARTS AND MATERIALS

S1—DPDT momentary pushbutton switch (RESET)  
S2—SPST toggle switch (ON/OFF)  
J1, J2—BNC connector to mate with oscilloscope's patch cable  
J3—open-circuit miniature jack (power connection)  
Plastic cabinet 4 $\frac{1}{4}$  × 2 $\frac{1}{2}$  × 1 $\frac{1}{4}$ -in., printed-circuit board materials, wire, hardware, solder, etc.  
\*Optional on-board regulated 5-volt DC power supply used with 9-12-volt DC battery eliminator  
+ Optional circuit for high-level sweep gates and ramps—may be deleted with TTL-level design and applications.

The following is available from E.T.C., P.O. Box 29278, Denver, CO 80229.

Bare circuit board \$10.00.

A complete set of parts for the Single Sweeper One per Fig. 4—\$40.00.

Optional power supply, which includes filter and bypass capacitors, regulator, and battery eliminator which plugs directly into the wall, supplying 9 to 12-volts of unregulated DC to unit—\$15.00.

manual-reset or new-sweep command signal, and may also be used to store or hold an external-pulsed reset command applied at IC1-b (pin 10).

But, whether by pulse or manual command, IC1-b's Q output (pin 9) going high enables IC2-b D input (pin 12). IC2-b is the single-sweep blanking control flip-flop which will set on the low-to-high leading edge of the sweep gate or similarly derived pulse, applied to its clock input (pin 11). When IC2-b gets set, it unblanks the scope's CRT via its Q (pin 9) or  $\bar{Q}$  (pin 8) outputs. Also, IC2-b's  $\bar{Q}$  (pin 8) going low resets IC1-b via its reset input (pin 13).

At the end of one scope-sweep cycle, the sweep gate will go low, which is inverted high by IC3-a and applied to the clock input of IC2-a (pin 3). IC2 Q output (pin 6) will go low resetting IC2-b via its reset input (pin 13), blanking the scope's CRT again. Also, the IC2-b Q output (pin 9) going low resets IC2-a via its reset input (pin 1).

The scope will remain blanked until a new sweep command is received by manual operation of S1 or a pulse is applied at IC1-b's set input (pin 10). See the typical timing diagram for a triggered scope using the single-sweep, blanking circuit in Fig. 5.

Operational status LED indicators (see Fig. 6) may be added and driven by the unused outputs of the flip-flops, or unused inverters which are used as buffer drivers. LED1 driven by IC1-a's outputs would indicate a manual reset. LED2 driven by IC1-b's outputs would indicate when the circuit was ready for a new command. And LED3 driven by IC2-b's outputs would indicate blanking status.

### Interface

Where high-level sweep gate or ramp inputs were used, the input signals might be pre-conditioned by a current-limiting resistor followed by a two-transistor scheme. See Fig. 7. However, the pre-conditioning circuit could be used to amplify a signal; but, the use of low-level sweep ramp

signals is not advised. Also, the user should avoid loading scope circuits or signals.

### Some applications

Where a scope has buffered ramp and/or gate outputs and Z-axis or intensity modulation inputs, like some Philips, Tektronix, Dumont, et al, oscilloscopes, adding the single-sweep blanking circuit of the Single Sweeper One (Fig. 4) is a simple matter. A "single sweeper" could be built into a

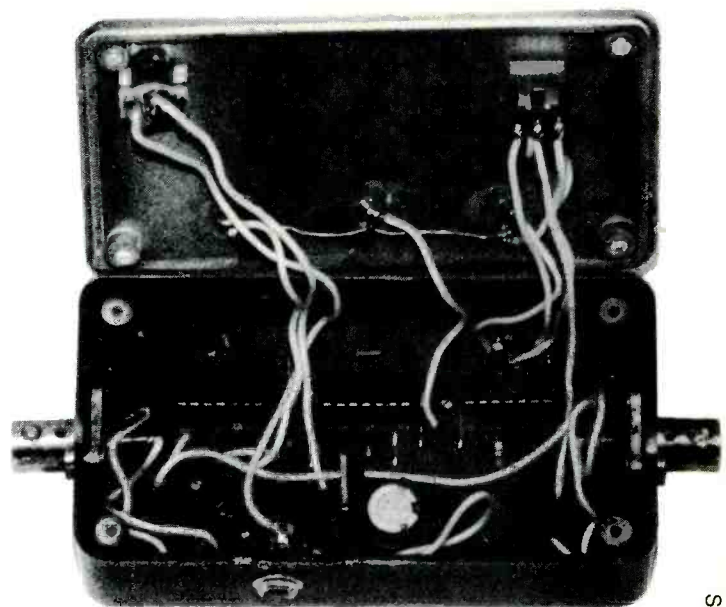

INSIDE VIEW OF THE SINGLE SWEEPER ONE made by the author. Printed-circuit board is secured to the bottom of the plastic case with dabs of RV cement. Use stranded wire to interconnect components mounted on cover. LED's are cemented in place with some epoxy glue.

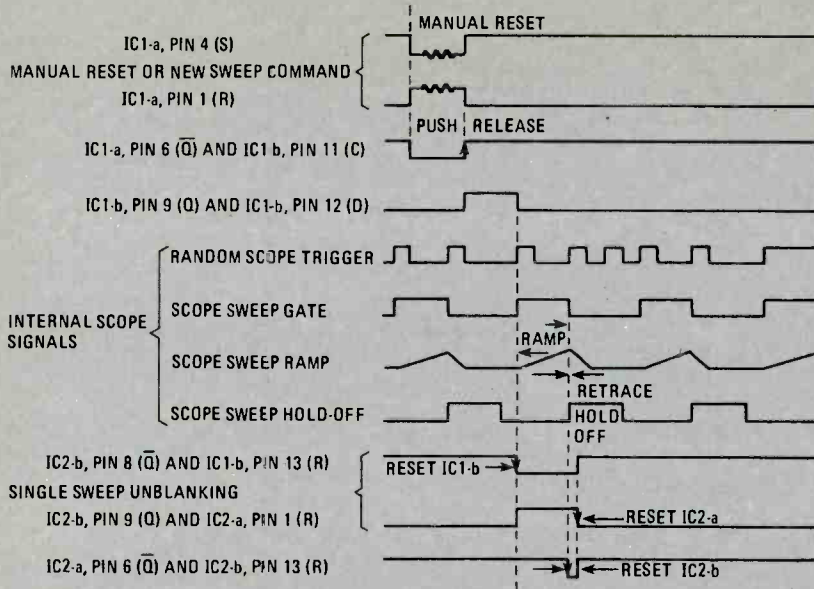

FIG. 5—TYPICAL TIMING DIAGRAM for a triggered-oscilloscope with a single-sweep blanking circuit. Take the time to fully understand the logic of action for each point in the circuit in relation to the other points.

mini box and plugged or switched in circuit, as in Fig. 1.

In the case of scopes like the Tektronix T 921/T922, with a TTL active-high and active-low sweep gate (IC-U2234D, pin 11 and IC-U2234A, pin 3, respectively) the blanking circuit in Fig. 4 could be switched in when needed, requiring no input pre-conditioning. However, in other scopes, using TTL logic on the sweep, time base, and/or horizontal amplifier boards, those signals can generally be located by referring to a schematic diagram or user manual. Also, a 5V signal into the Z-axis input on the back of this particular scope will cause a noticeable decrease in intensity, where the maximum input is 50 volts.

Therefore, a low level input into the Z-axis, with front-panel intensity adjustment might be used, or a voltage translation circuit with output-level adjustment could be used. The circuit could be plugged in when needed, if the sweep gate was made an external output or added internally, with suitable switching. Further, you might give some thought to buffering the sweep ramp and gate, bringing them to the back panel as outputs.

In the case of scopes like Heathkit's I0-4510, with TTL active-high and active-low sweep gate (IC-404, pin 9 and IC404, pin 8, respectively) the blanking circuit (in Fig. 4 for the Single Sweeper One) again requires no input pre-conditioning. However, there's no Z-axis input you can tie into, so you'll have to use the blanking-control circuits. In that, and similar applications, where TTL level signals con-

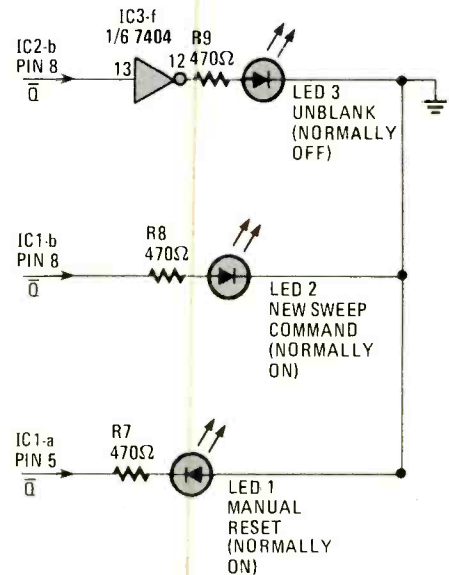

FIG. 6—LED INDICATORS clue you to the action taking place in Single Sweeper One. You may want to add a few more LED's especially when the unit will be used with extremely slow sweeping circuits. Under that condition, the LED's operate slowly enough for the eye to follow. Is it necessary? No—but nice to see!

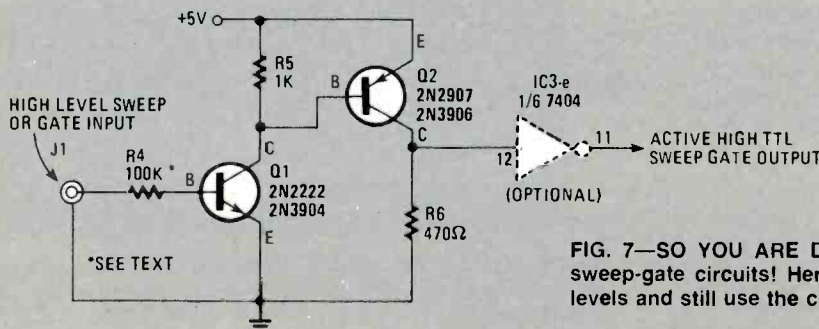

FIG. 7—SO YOU ARE DEALING WITH high-level sweep and sweep-gate circuits! Here's how you can cope with the high levels and still use the circuit in Fig. 4.

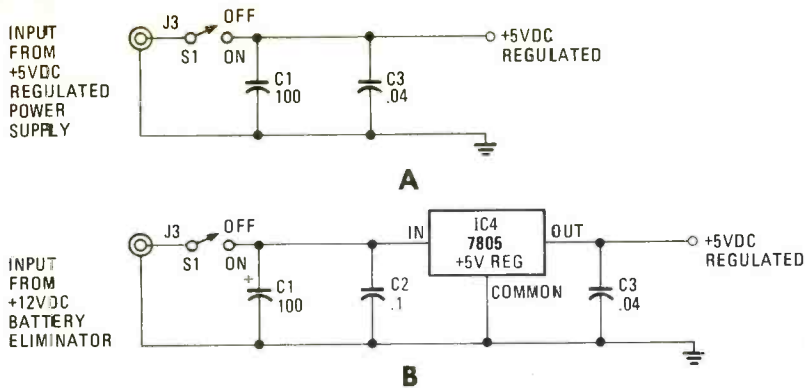

FIG 8.—POWER YOU NEED, POWER YOU GET! In A above, you can tap right into a bench-operated regulated 5-volt DC power supply, but that ties you to the bench area. In B below, you can be powered by an AC operated 9 to 12-volt battery eliminator, and operate anywhere there's an outlet in sight. Otherwise, plug in a 9 to 12-volt battery pack to go portable.

control the blanking amplifier on the deflection circuit board, additional AND or NAND gates may be used to take control of the blanking amplifier.

Now, virtually any scope, where you can pick off the sweep-time-base and which has Z-axis control, intensity modulation, and/or blanking can be modified for single-sweep blanking control with the Single Sweeper One. And we've only covered a few specific cases here; however, with a working knowledge of how your particular oscilloscope operates, the circuit in Fig. 4 can generally be modified to work.

### Power option

You could either outboard a 5-volt DC supply that is regulated, or pump in approximately 12-volt DC from a plug-in battery eliminator and install a regulated 5-volt DC circuit within the unit. Additionally, you could use a 9 to 12-volt DC battery pack with the regulator circuit. Refer to Fig. 8 for the schematic diagram. The parts for that circuit addition have foil leads and holes provided on the printed-circuit board illustrated in Fig. 9. The location of parts and jumpers are illustrated in Fig. 10.

The Single Sweeper One is a designer's dream project. If you use your oscilloscope a great deal, this project is one that may be what the Z-axis ordered. **SP**

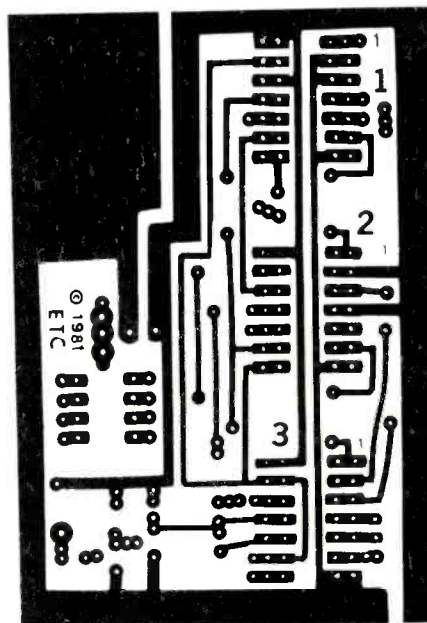
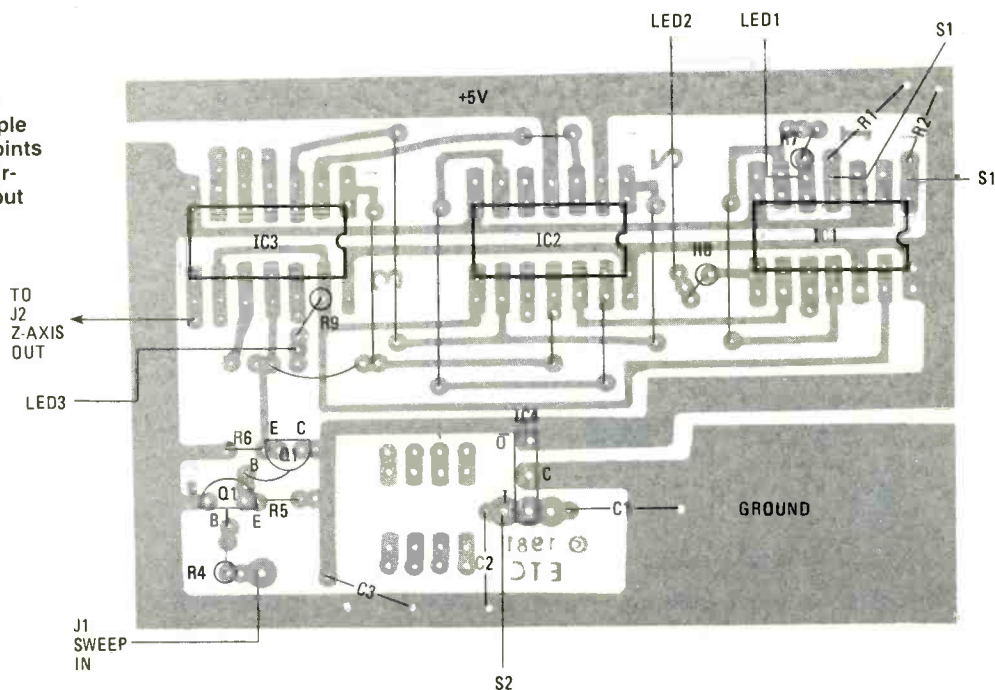

FIG. 9—FULL-SIZE PRINTED-CIRCUIT BOARD for the Single Sweeper One has more copper elements than needed to wire the circuit. The author designed the board for the original Single Sweeper, and after circuit modifications reduced the total number of circuit parts. One section of IC3 is not used—you may come up with something and the extra soldering points may come in handy.

FIG. 10—PARTS LOCATION DIAGRAM indicates that there is ample room for circuit parts, plus tie points for experimental work with the circuit. IC4 may run slightly warm but no heat sink is necessary.



# SUPER-SENSITIVE SIMPLE VOLTMETER

EVERT FRUITMAN



HOW WOULD YOU LIKE TO BE ABLE TO MEASURE AGC AND OTHER low-level voltages without loading down the circuit, or your budget? Here is an instrument we call the Super-Sensitive Simple Voltmeter (SSSV) that will measure from 2-millivolts to 2-volts DC with an input impedance of 500,000 ohms, or higher. The circuit may be added to your present voltmeter, or built as a separate instrument. All of that is yours for the price of an op amp, a few resistors, and an inexpensive meter movement.

## Theory

The primitive DC voltmeter shown in Fig. 1 is good for checking batteries and other similar low-impedance circuits. All of the current needed to move the meter's pointer comes from the circuit under test. In the low-voltage circuit of Fig. 2, the 1 milliamperes that the meter needs for pointer movement represents more current than the circuit would deliver under normal operation. Since the meter's current loads down the circuit, the meter indications would be *in error* by a



FIG. 1—THE TIME-HONORED voltmeter circuit that serves well in testing low-impedance voltage sources accurately. Ideally suitable for checking batteries, power supplies and low-impedance circuits. This is not the voltmeter to check low AGC voltages.

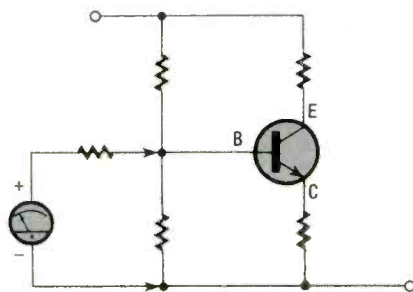

FIG. 2—DISASTER STRIKES when a low-impedance voltmeter attempts to measure the base bias of this transistor circuit. The meter circuit radically alters the resistive-biasing network causing abnormal operation and an incorrect (and worthless) voltage reading. Even worse, the transistor may be destroyed.

large magnitude, and the circuit would *not operate normally* while it is being tested. There are several simple remedies for those ills!

By putting a simple high-impedance amplifier in front of the basic voltmeter, the circuit under test will not know that there is a voltmeter connected to it. The power needed to move the meter's pointer comes from the batteries and is controlled by the amplifier. The circuit continues to function in its normal manner and you are able to read voltages under working circuit conditions. There are many good voltmeters on the market that will not load down the circuit but they don't go down below 1 or 2 volts, which means that the reading is just barely seen as a flicker of the pointer coming off the zero mark.

The high-impedance amplifier permits the use of a low-sensitivity (1000 ohm/volt) VOM, or an inexpensive meter movement. Furthermore, voltages less than 10 millivolts may be read on a meter that normally needs 1 or 2 volts just to kick the pointer slightly.

## Getting advanced

The simplified voltmeter circuit in Fig. 3 shows an in-

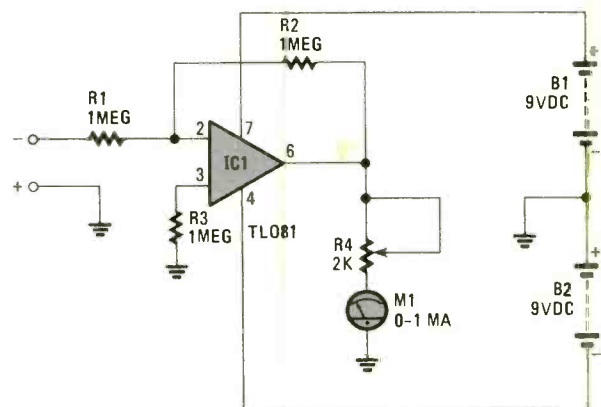
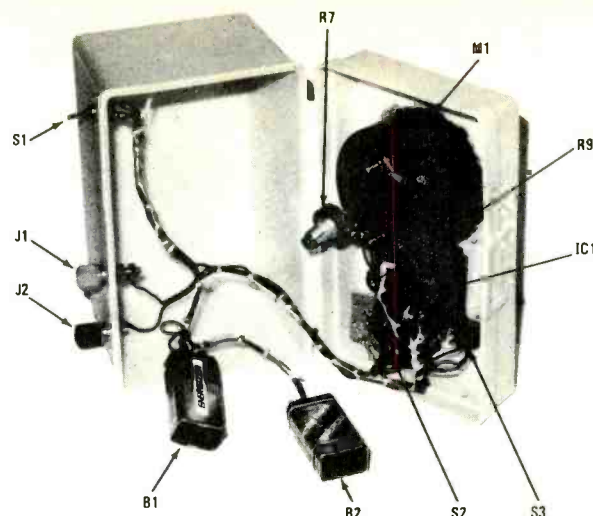

FIG. 3—BASIC CIRCUIT from which the SSSV grew. This one-range voltmeter measures 0 to 2-volts DC accurately with usable increments of 0.05 volt. The input impedance of this circuit is one-million ohms and draws only 2 microamperes maximum from the circuit under test.

# High-impedance voltmeter places more than 500,000 ohms between readable voltages as low as 2 millivolts and the meter!



THE FLIP-TOP COVER of the card-file box makes for easy assembly of the SSSV. With the heavy components on the cover, the unit is a bit top-heavy. You may want to mount a burned-out transformer in the bottom of the light, top-heavy plastic case to reduce the "tip-ability" and increase the "heft-ability."

expensive 0-1 milliampere meter connected to an op amp, IC1, which raises the voltmeter's effective input impedance, and offers the opportunity for amplifying low voltages in high-impedance circuits. The input impedance in this case is one-million ohms. With  $R1 = R2 = 1$  Megohm, 1-volt input gives 1-volt output at pin 6 of IC1. With  $R4$  adjusted for just under 2000 ohms, then 2-volts input will give full-scale deflection on the meter; also, only 2 microamperes are drawn from the circuit under tests. That 2 microamperes could be cut down by making resistors  $R1$  and  $R2$  10 Megohms each, but it really isn't necessary.

So far we have improved the loading characteristics of the basic meter. We can take advantage of the op amp's gain by making  $R2$  larger than  $R1$ . Resistors,  $R1$ ,  $R2$  and  $R3$  (Fig. 4) are lower in value, which reduces the input impedance somewhat. You may wish to make  $R5$  larger and keep  $R1$  as a fixed value.

To roll your own SSSV, you need to know that the gain of the system in Fig. 4 is the ratio of  $R5/R1$ . That means that if  $R5$  is 10 Megohms and  $R1$  is 1 Megohm; then 0.1-volt input gives 1.0-volt output. That is a practical, but not theoretical, limit for what is being done here.

The overall sensitivity of the SSSV may be increased by adjusting the basic meter for 0.2 volts. That is done with the aid of  $S3$  and resistors  $R8$  and  $R9$ . See Fig. 4. Although the op amp is still delivering 1 volt to its output terminal, it has to deliver a little more current than before. The additional current drain is well within its capabilities.

The net result of that last maneuver is a meter with six ranges covering 50-millivolt to 2-volt full scale, and an input impedance of at least 500,000 ohms. As little as 2 millivolts may be read on the lowest range of SSSV. That makes it a handy null indicator for Wheatstone bridges, and other DC nulling devices.

## Putting it together

The cabinet for the SSSV is a 4 × 6-inch plastic, card-file box. Use a plastic case unless your meter states that it is calibrated for use on steel panels. If all you are going to make is the amplifier part and use it with an existing voltmeter, then the smaller 3 × 5-inch card-file box will be big enough. Most of the smaller parts were mounted on a piece of surplus perfboard. That in turn was hung on the back of the meter movement, as shown in the photo. Of course, we're talking about wiring up the schematic diagram in Fig. 4. The meter, switches, binding posts, and if you like, the low-power pilot light, mount on the box. The layout may be anything that you like when you wire up your SSSV.

The low-power pilot light, Fig. 5, draws very little power, and its friendly flicker is a good reminder to turn off the batteries. That is necessary because the meter normally sits on zero and requires no electrical zeroing. As a result, there is

FIG. 4—BUILD THIS version of the SSSV. By setting switches  $S2$  and  $S3$  to desired positions you can measure full-scale, DC voltages from 50-millivolts to 2 volts. Input impedance is related to the selected resistor made by switch setting of  $S2$ —thus selecting either  $R1$ ,  $R2$  or  $R3$ .

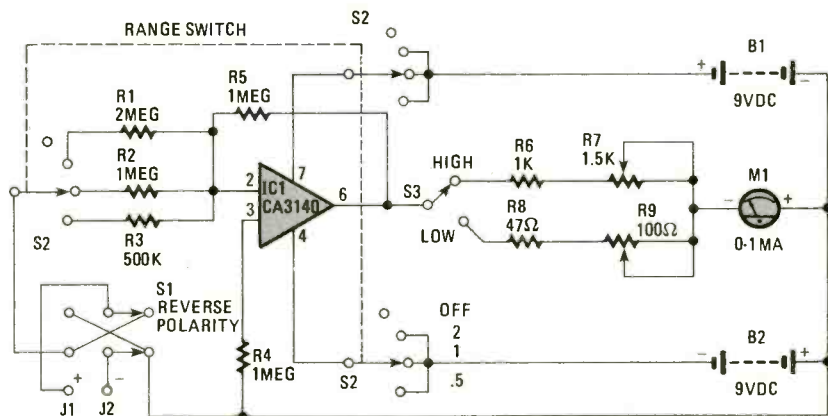

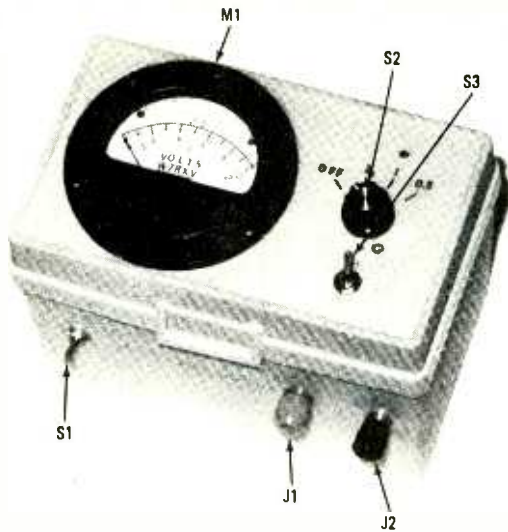

COMPLETED SSSV looks as if it belongs on a lab bench. You may want to change location of switches and that presents no problem in construction. Location of J1 and J2 is ideal because test leads will not lay over switches and meter M1. Also, a slight tug on the test leads will not tip over the meter case.

no real indication that the unit is turned on, and slowly draining the batteries.

Use one of the BiFET op amps such as the CA3140 or the TL081 for best results in your SSSV. The input offsets in the 741 op amp won't allow its use on the extreme low ranges.

### Checkout and calibration

After everything is wired, and before the BiFET chip, IC1, is plugged in, connect the batteries to the SSSV and check with a voltmeter to be certain that pin 7 is positive with respect to pin 4. Refer to Fig. 4. If that is OK, turn S2 OFF and plug in IC1. Set the range switch, S3 for the highest voltage—2 volts in this case. Connect a voltmeter and a

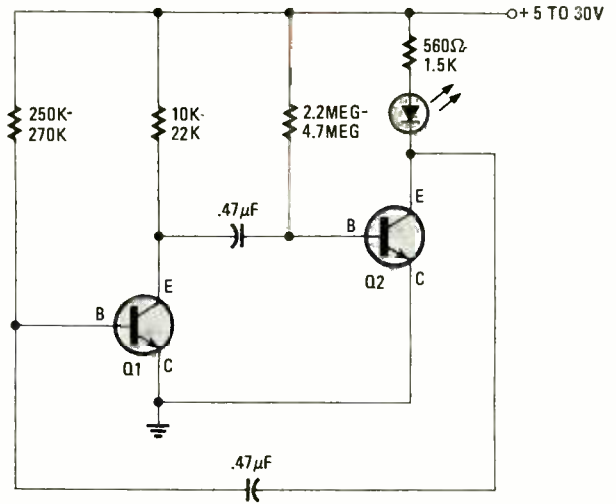

Q1, Q2—GENERAL PURPOSE NPN SILICON TRANSISTORS

FIG. 5—LOW-POWER PILOT LIGHT is an optional feature in SSSV. Consider it a project all by itself with application not only in SSSV, but in many other projects where pilot-light indication is necessary and a transistor 9-volt battery is used as the power supply. The low drain does not shorten the battery's shelf life.

single cell from a flashlight across the input terminals. Turn it on. (use the polarity-reversing switch, S1, if needed) and adjust R7 (Fig. 4) for the same reading as the shop voltmeter. So much for the high-range calibration. Accurate calibration of the low range is a bit more difficult unless you have access to a calibrated millivolt source.

The low-range calibration for the SSSV setup is shown in Fig. 6. It uses parts that you are likely to have around the shop. The wiper, (moving contact), and the ends of a 500-ohm potentiometer are connected to the input terminals of SSSV. An ordinary ohmmeter is paralleled across that potentiometer. Set the ohmmeter for  $R \times 10$  or  $R \times 100$ . That makes it a crude current source. Set S2 on SSSV to 2 volts. Adjust the 500-ohm potentiometer for a meter reading of about  $\frac{1}{2}$  volt. Move range switch S2 down to the 0.5-volt position. Adjust the potentiometer for as close to 0.05 volts as you can. That will be the first major meter division. Move S3 (Fig. 4) to the low-range position and adjust R9 for full-scale deflection. Disconnect the ohmmeter and the extra potentiometer. *That's it!* You are ready to measure from a few millivolts, to 2 volts DC, with at least 500,000-ohms input resistance.

The Super Sensitive Simple Voltmeter will give you that extra measure of resolution that you always wanted on those low-voltage readings. **SP**

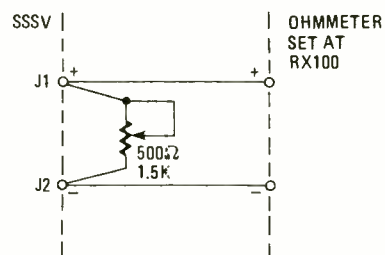

FIG. 6—SEEMS SCREWY to use an ohmmeter to calibrate a voltmeter, but that's exactly the case. The ohmmeter is used as a constant current source to provide a selectable scale deflection on the voltmeter's HIGH range setting of S3. Then, switch S3 is flipped to low and adjustment is made. See text for details.

### PARTS LIST FOR SSSV

#### RESISTORS

All fixed resistors are  $\frac{1}{4}$ -watt, 5% values unless otherwise noted.

- R1—2-Megohms (2 1-Megohm units in series)
- R2, R4, R5—1-Megohm
- R3—500,000-ohms (2 1-Megohm units in parallel)
- R6—1000-ohms
- R7—1500-ohms potentiometer
- R8—47-ohms
- R9—100-ohms potentiometer

#### SWITCHES

- S1—DPDT miniature toggle or slide switch
- S2—3-pole, 4-position rotary switch
- S3—SPDT miniature toggle or slide switch

#### ADDITIONAL PARTS AND MATERIALS

- B1, B2—9-VDC transistor battery
- IC1—CA3140E or TL081 BiFET operational amplifier
- J1, J2—Multi-way binding post; one red, one black
- M1—0-1-mA panel meter, 2 to 3-in. circular or rectangular face
- Plastic 4- x 6-in. card-file box (see text), battery clips, perfboard scraps, wire, hardware, solder, etc.



# MINI AUDIO GENERATOR

JOHN PORTER

**Here's an one-chip test-gear project that's worth its weight in Hertz!**



BUILT FOR USE IN TROUBLE-SHOOTING AUDIO SYSTEMS, THE simplicity and low cost of the Mini Audio Generator should make it of interest to anyone involved in servicing audio and radio equipment. Built around a single inexpensive integrated chip, this little generator will provide many of the functions found on instruments costing 20 times as much.

Contained in a  $2\frac{1}{2} \times 2\frac{1}{2} \times 4$ -inch aluminum chassis box, the generator is capable of putting out a signal ranging from 2 Hz to 18 KHz at a strength of up to 10 volts peak-to-peak. It will easily drive a speaker directly, making it ideal for signal-injection testing.

## The circuit

Utilizing only the VCO section of the 4046 chip, the output frequency is controlled by the amount of voltage fed to pin 9, that being controlled by R1. (See Fig. 1)

C1 and R2 determine the operating frequency range of the VCO. Potentiometer R3 acts as a voltage divider to control the amount of signal available at output jack J1.

The squarewave output will be rounded off at the leading edge somewhat at the higher frequencies. The strong output is partly due to C2, which charges up on one half of the cycle, only to discharge on the second half, adding its charge to the

pulse coming from the I.C. That makes it possible to obtain a 10-volt peak-to-peak signal although the generator is only powered by a 9-volt battery. (Of course, that amount of signal is only available with very light loading.)

The 4046 was chosen because it doesn't require a dual-voltage power supply, nor does it need a regulated supply. Also, CMOS chips draw less power than TTL chips, contributing to battery life.

The reason why R1 is not calibrated in the Mini Audio Generator is that output frequency varies as the battery ages. That could be eliminated by adding a 7.5-volt DC regulator

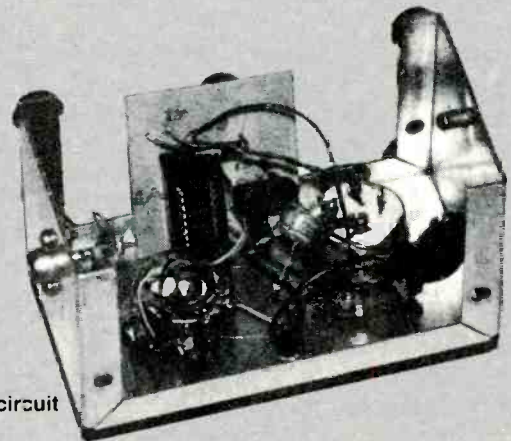

COVER-OFF VIEW OF THE MINI AUDIO GENERATOR reveals a miniature circuit board which mounts the IC and several other small circuit parts.

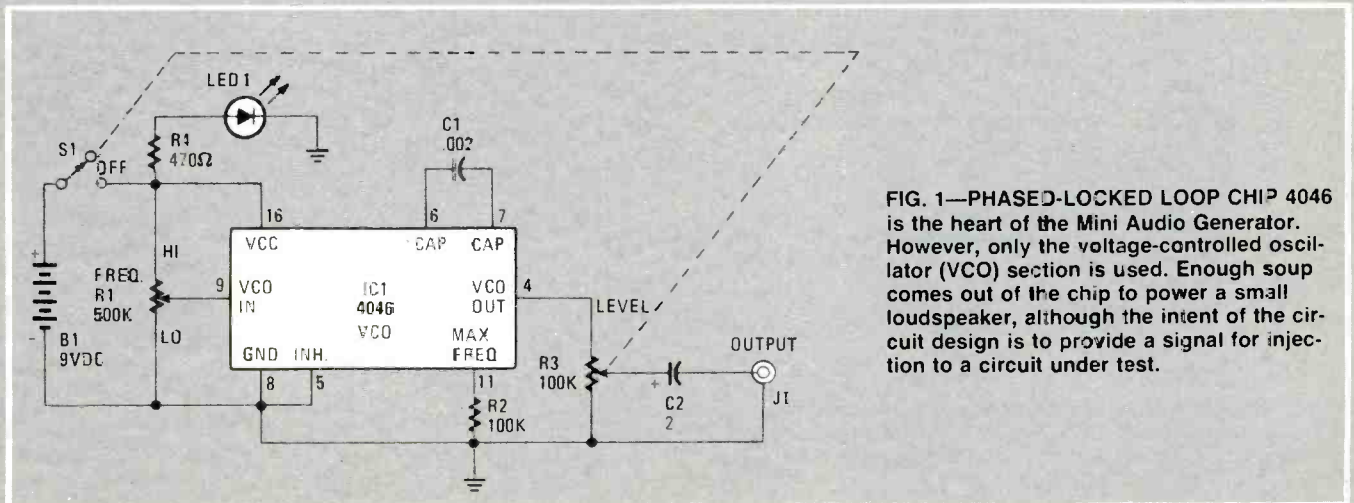

FIG. 1—PHASE-LOCKED LOOP CHIP 4046 is the heart of the Mini Audio Generator. However, only the voltage-controlled oscillator (VCO) section is used. Enough soup comes out of the chip to power a small loudspeaker, although the intent of the circuit design is to provide a signal for injection to a circuit under test.

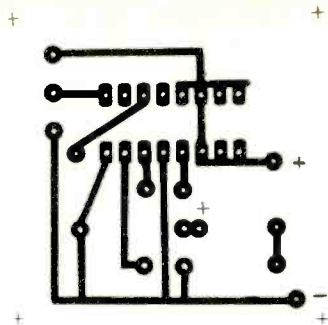

FIG 2.—FOIL-SIDE VIEW of the printed-circuit board copper foil. This illustration can be used as a pattern for making yours. If you wish, use pre-etched standard-layout boards to construct the circuit and save the etching mess. Otherwise, you may consider wire-wrapping the circuit.

(a Zener-type circuit), but when originally designed the plan was to try for the least amount of parts within the circuit.

### Building it

The Mini Audio Generator, if built exactly as shown, should cost less than \$10.00, including the etchant for making the printed-circuit board. Fig. 2 is a same-size foil pattern used on the author's printed-circuit board. The circuit is so simple you may choose point-to-point wiring using the wire-wrap technique. There's nothing wrong with that idea! Fig. 3 shows the printed-circuit board with an X-ray view of the foil surface and the parts mounted on the board. Placement of parts is not critical so you may design your own printed-circuit board.

Since the 4046 is a CMOS chip, the proper handling precautions relating to static electricity should be observed.

Furnishing such a healthy signal requires a fairly large supply of current (at least by CMOS standards) so LED1 is used as a power-on indicator, and reminds you to turn the Mini Audio Generator off when you are not using it, so as to conserve the battery. For best circuit results alkaline batteries are recommended.

Parts values are not at all critical, and close substitutions are permissible.

The Mini Audio Generator is a tough and versatile circuit. The author has used the generator and stored it in his traveling toolbox for more than a year, during which time it performed as required. **SP**

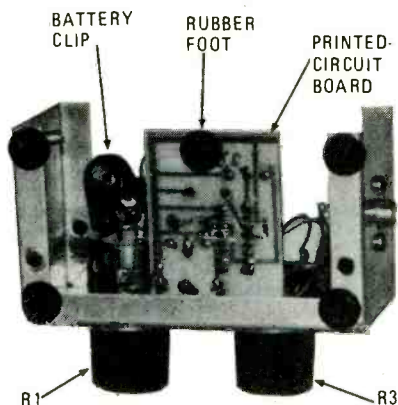

INSIDE THE MINI AUDIO GENERATOR shows plenty of room for the positioning of circuit parts. No problem here squeezing in all the parts. Note that rubber foot on printed-circuit board was added so as to eliminate the possibility of board touching the side of the chassis-box cover and shorting the circuit.

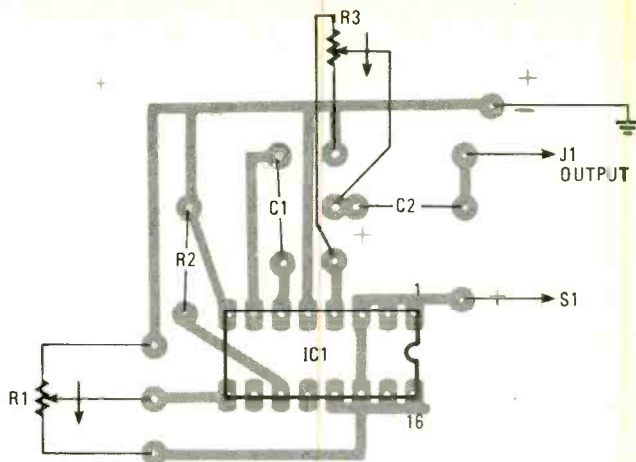
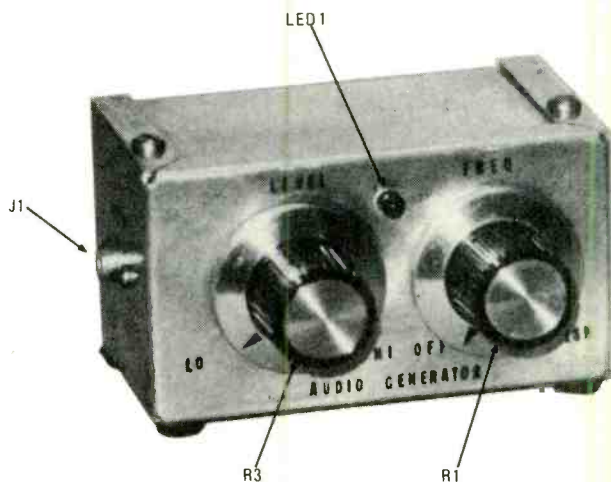

FIG 3.—HERE'S AN X-RAY VIEW of the printed-circuit board with the parts mounted on the "flop" side of the foil surface. Nothing is too critical, so that the novice could "re-layout" the design successfully to suit his own requirements.

### PARTS LIST FOR MINI AUDIO GENERATOR

- B1—9-VDC transistor battery
  - C1—.002- $\mu$ F, 25-WVDC ceramic capacitor
  - C2—2- $\mu$ F, 15-WVDC electrolytic capacitor
  - IC1—4046 phased-locked loop integrated circuit
  - J1—RCA phono jack
  - LED1—light emitting diode, red diffused lens
  - R1—500,000-ohm to 1-Megohm potentiometer
  - R2—100,000-ohm, 1/2-watt resistor
  - R3—100,000-ohm potentiometer with SPST switch (see S1 below)
  - R4—470-ohm, 1/2-watt resistor
  - S1—SPST switch mounted on shaft of R3; optional toggle-switch replacement may be used
- Printed-circuit material to fabricate 1 1/2 x 2-in. printed-circuit board, 9-VDC transistor-battery connector, 4 x 2 1/4 x 2 1/4-in. aluminum chassis box, 16-pin DIP socket, knobs, hardware, wire, solder, etc.



IT'S WHAT'S UP FRONT THAT COUNTS when you are ready to operate the Mini Audio Generator as a test device. LED1 is a power-on device serving to prevent accidental battery drain.

# Radio-Electronics

HOW TO REJUVENATE  
ANTIQUÉ RADIOS

\$1.50 MAR. 198

COMPUTERS - VIDEO - STEREO - TECHNOLOGY - SERVICE

Portable  
**SHORTWAVE RECEIVER**  
Buyers guide

Inside the new  
**767 COCKPIT**

Build an  
**ACTIVE ANTENNA**  
for your VLF receiver

Back-to-school series  
**POWER AMPLIFIERS**

Inexpensive and versatile  
**2 DVM CIRCUITS**  
you can build

PLUS:

★ Videogames ★ Hobby Corner  
★ Computer Corner ★ Drawing Board  
★ State-Of-Solid-State ★ Equipment Reports



This will be  
coming to you  
when you  
subscribe to  
**Radio-Electronics:**

- **HELPFUL CONSTRUCTION ARTICLES . . .**
  - Test Equipment
  - Hi-Fi Accessories
  - Telephone Accessories
  - Music Synthesizers
  - Computer Equipment
  - Automotive Equipment
  - Intruder Alarms
  - Home & Car
  - Video Accessories

- **NEWS ON NEW TECHNOLOGY . . .**
  - Computers
  - Microprocessors
  - Satellite TV
  - Teletext
  - Automotive Electronics
  - Speech Synthesizers
  - IC Applications

- **FASCINATING "HOW TO DO IT" ARTICLES . . .**
  - Build Your Own Projects
  - Make Your Own PC Boards
  - Wiring Techniques
  - Soldering and Desoldering
  - Design and Prototyping

- **HOW YOU AND THE COMPUTER CAN BE FRIENDS . . .**

Getting Started  
Programs, Circuit  
Design, Games  
A/D-D/A Interfacing  
Peripheral Equipment

- **NEW AUDIO DIMENSIONS FOR YOUR PLEASURE . . .**

Noise-Reduction Devices  
How to Connect that  
Extra Add-On  
Hi-Fi Accessories  
New Technology

- **TV WONDERS FOR YOUR FUTURE . . .**

Latest Receivers and  
Circuits  
The Home Entertainment  
Center  
Projection TV Today  
Satellite TV Receivers  
Jack Darr's Monthly  
Service Clinic  
Service Problems and  
Solutions

- **AND you also get these regular MONTHLY FEATURES:**

- **LOOKING AHEAD**  
by Dave Lachenbruch
- **HOBBY CORNER**  
by "Doc" Savage
- **STATE-OF-SOLID-STATE**  
by Bob Scott
- **WHAT'S NEWS**, new  
products, stereo news
- **VIDEOGAMES**, new  
products, game reviews
- and **NEW IDEAS, STEREO  
PRODUCTS, NEW  
COMPUTER PRODUCTS  
FOR HOME/JOB and  
MUCH MORE!**

**Radio-Electronics** covers all  
aspects of the fast moving  
electronics field . . . featuring  
**COMPUTERS • VIDEO • STEREO  
TECHNOLOGY • SERVICE  
COMMUNICATIONS • PROJECTS**

# Get it all!

Subscribe today to **Radio-Electronics**. Don't miss a single  
issue and . . . you save as much as \$7.03 off the  
newsstand price.

When you select one of the subscription offers listed on the handy  
coupon—you'll be assured of having your copy reserved,  
even if it sells out on the newsstand. Make sure  
you get all the excitement in every issue of  
**Radio-Electronics**, every month, by  
filling in and mailing the  
coupon, today.

Mail to: **Radio-Electronics**  
P.O. Box 2520, Boulder, CO 80322

**Every Month!**  
**Get the Best—Mail Today!**

7HE35

- 1 year—**12 issues only \$14.97** (You save \$3.03 off newsstand price.)  
 2 years—**(Save More)—24 issues—\$28.97** (Save \$7.03 off the newsstand price.)

- Payment Enclosed  
 Bill Me

Name \_\_\_\_\_ (please print)

Address \_\_\_\_\_

City \_\_\_\_\_ State \_\_\_\_\_ Zip Code \_\_\_\_\_

Offer Valid In U.S. Funds Only

Canada—Add \$3.00 per year

# Retrofitting the Sinclair/Timex for a standard

**Now you can cut out the middleman by driving the video monitor directly from the bargain computer for maximum picture clarity—the idea is expandable!**

PERSONAL COMPUTERS THAT USE A STANDARD TV SET AS THE monitor all suffer from reduced resolution because of the inherent limitations of the TV itself. But feed the very same video display to a standard TV monitor, even a 6-MHz model made for closed-circuit television, and the increased sharpness and resolution is astounding.

A case in point is the Sinclair ZX/81 and its twin sister the Timex/1000. The very same display that is best described as "passable" on a TV set becomes razor sharp on a monitor.

What's that? You thought a TV was a monitor? OK—let's take time out to explain. At best, a TV set has a 4-MHz bandwidth because the American TV standards only require a 4-MHz bandwidth. The fact that we might call a TV set a "monitor" if it's used to display anything other than a TV broadcast signal doesn't change the fact that it remains a TV set with a 4-MHz bandwidth. Now 4 MHz might be fine for a TV picture, but it's not all that good for small (minute) characters; they tend to get fuzzy (unsharp) and run together. To get around the lack of definition when displaying characters, personal computers intended for use with "TV monitors" generally use relatively large characters.

Real "computer monitors" are not TV receivers. They are only the "business end" of a receiver: the video amplifier(s) and CRT, and they are relatively "wideband". As a general rule, even the lowest-cost video monitor intended for use with closed-circuit surveillance TV cameras has a bandwidth of at least 6 or 8 MHz. Then there are real computer video monitors with a bandwidth of 9-12 MHz, 18 MHz, or even 20 MHz. They can put up to 80 characters across a CRT with razor-sharp outlines.

Today, you can pick up a wideband video monitor for as little as \$100 from the discount stores. The problem is that most computers that are designed to utilize a standard TV as a "monitor", such the Sinclair ZX/81 and Timex/1000, are designed *only* for use with a standard TV set.

Yet with less than a \$1 worth of parts, and about 30 minutes' work, both the Sinclair and Timex computers can be modified to work with either a standard TV or a video monitor.

## Simple theory

Fig. 1 shows a simplified block diagram of the Sinclair/Timex computer. The computer's composite video output is fed into a "TV modulator module"—actually a miniature low-power TV transmitter—that "broadcasts" the computer's display to the TV receiver through a length of shielded (coaxial) cable. The module's output is on TV channel 2 or

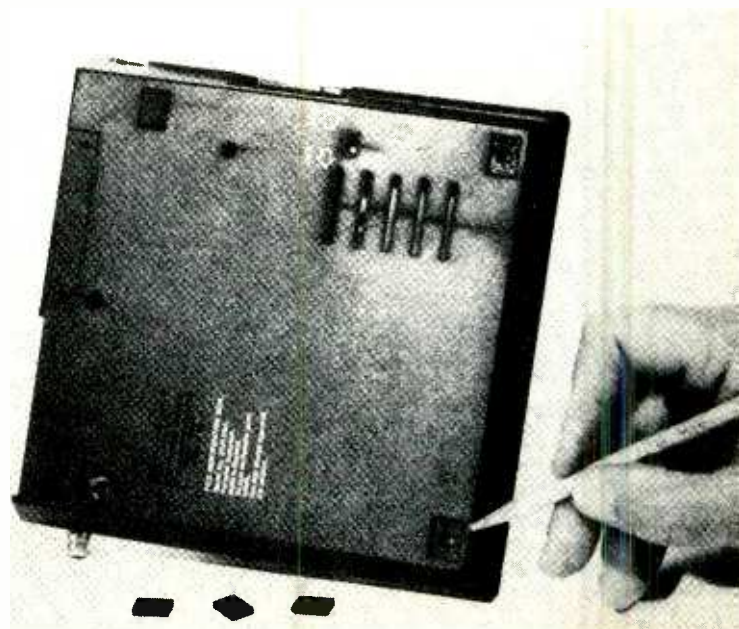

# Computer video output!

HERB FRIEDMAN

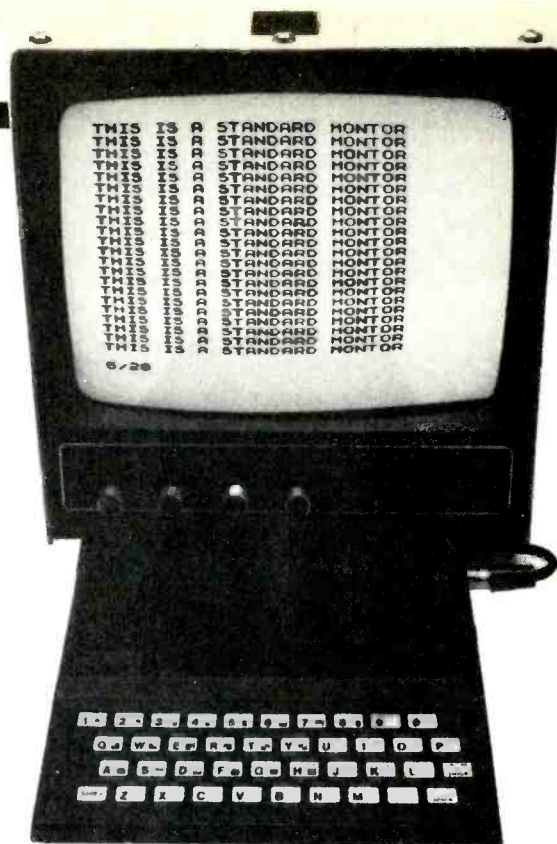

3—the user selects the channel that is not in use in his or her local area. The actual “transmitter” output connection is a phono jack built into the modulator module.

To provide a low-Z (low impedance) video monitor output

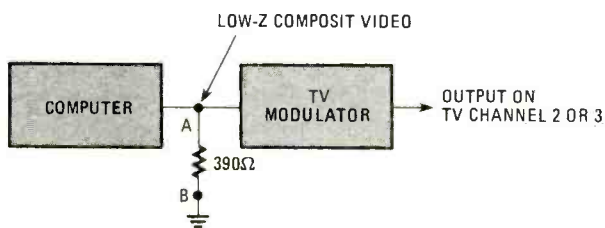

▲ FIG. 1—SIMPLIFIED BLOCK DIAGRAM of Sinclair/Timex computer(s). The low-impedance composite video output is fed to a TV modulator module—which is actually a miniature transmitter. It provides an RF output on TV channels 2 or 3. The internal video load resistor is 390 ohms. The low-Z output is taken from across the 390-ohm resistor at points A and B with A being high.

in addition to the normal TV “broadcast” output, all that’s needed is a “bridge” connection across the computer’s video at the input to the TV module. By routing the low impedance video output to a standard phono jack the output cable supplied with the computer can be used for either the low-Z video or TV outputs.

## No-hassle retrofit

The actual modifications to the computer aren’t difficult to do, and the photographs show how it’s done without damage to the computer.

First step is to open the computer’s cabinet, which is easy

◀ FIG. 2—THREE MOUNTING SCREWS are concealed behind the cabinet’s rubber mounting feet. The pencil points to one of those screws. Simply pull or peel the feet off the cabinet to gain access to the screws.

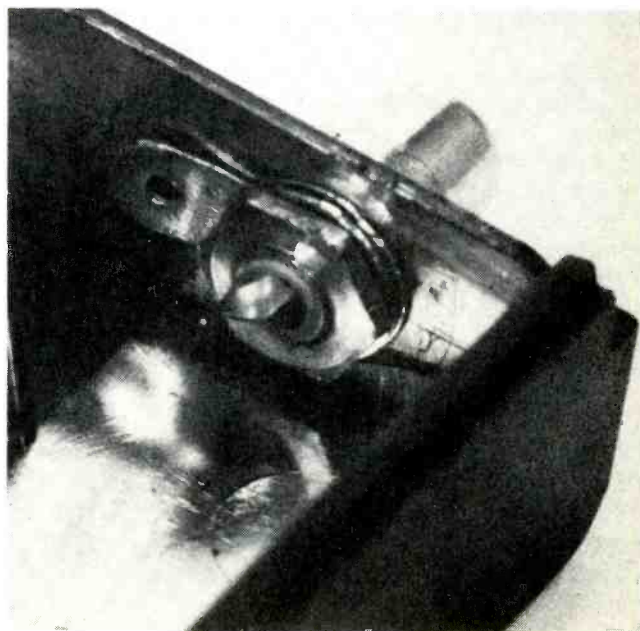

▶ FIG. 3—THE PHONO JACK used for the low-Z video output is mounted at the rear-right of the cabinet. Note that a ground lug is installed under the mounting screw. The lug is generally supplied with the jack when purchased.

if you know about the old "hidden screw trick" shown in Fig. 2. Flip the computer over on its keyboard. On the bottom of the computer you'll see two screws and four rubber mounting pads that are used as anti-scratch "feet". Three of the pads conceal a mounting screw. The pad directly above the TV channel selector switch does not conceal a mounting screw. Pull off the other three pads. If they're stuck, *pull hard*; you'll glue the pads back when you're finished.

Remove the three screws concealed by the pads and the two screws that are "in the clear". Gently separate the case. You'll be looking at the back of the main circuit board and the keyboard. The two are connected by a section of ribbon cable. Locate the two assembly screws holding the main board and remove them. Gently flip the board over on the keyboard section—that will expose the entire cabinet area under the circuit board.

There is one safe area for installing a video jack that will not interfere with any future peripherals for the Sinclair/Timex computer. It is located at the top right side near the memory expansion edge connector. Carefully drill a 1/4-in. hole for a phono jack—the type that mounts with a single nut

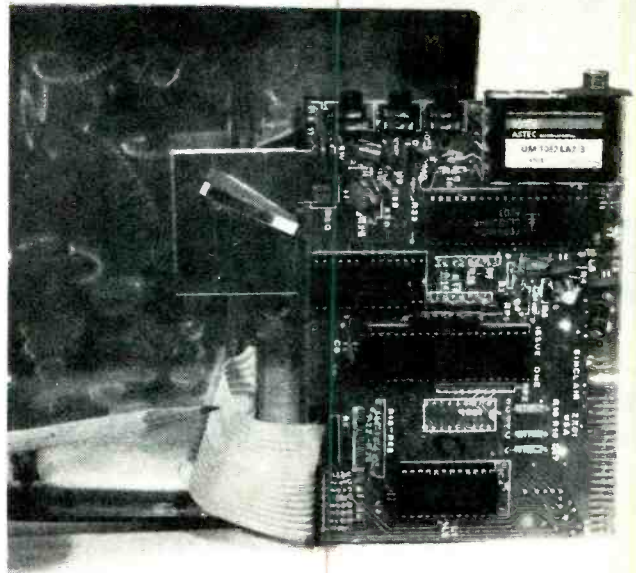

▲ FIG. 4—PENCIL POINTS TO the flexible ribbon cable that connects the main circuit board to the keyboard. This is how it appears when the circuit board is folded up against the keyboard. Take extra care that you don't squish or squarsh the cable by pressing against it. The TV modulator (transmitter) is at the upper right of the board.

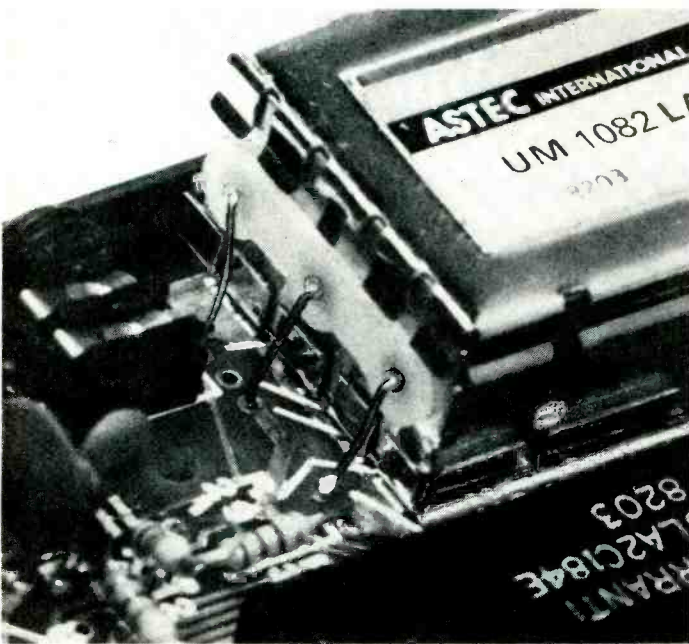

◀ FIG. 5—THE TV MODULATOR has three wires at one end. The one closest to the edge of the circuit board is the video input. There is a ground foil on the circuit board directly below the video wire to which the shield will connect.

FIG. 6—THE VIDEO WIRE to the modulator is pointed out by the pencil point. A shielded output cable is tacksoldered to this wire. The shield lead is connected to the ground foil immediately below the hot video lead.

threaded on the body. Make certain that you use the supplied ground lug as show in Fig. 3. Although the inside of the plastic cabinet is "flashed" with a metallic coating to provide a shield (ground) for the computer, use the jack's ground lug if you want to ensure a stable TV display.

Both before and after installing the phono jack, take extreme care not to damage the ribbon cable that connects the keyboard to the main circuit board. (In Fig. 4 the pencil points to the ribbon cable.) For the remainder of the retrofit, the circuit board will be folded back on the keyboard and there will be a broad bend in the ribbon. Take extra care that you do not lean into the ribbon and crease it. The cable isn't all that delicate but it *will* break if you press it hard. Refer to Fig. 4 and note that the module at the upper right labeled UM 1082. That is the TV modulator.

Fig. 5 shows a close-up of the left side of the TV module. The three wires coming out of the module are the video input (closest to the far edge of the printed-circuit board), the DC power supply (the center wire), and the channel 3 selector (wire nearest you). The metal frame of the module itself is the

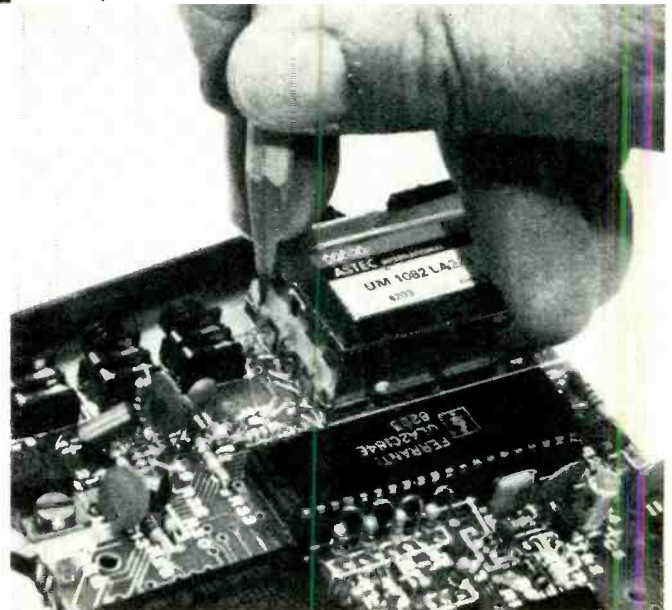

ground. For clarity, in Fig. 6 the pencil points to the video-input wire, the wire you will bridge for the low-Z video output.

Carefully prepare the end of short length of *thin* coaxial cable such as RG-174/U, or even standard audio shielded cable. Just be certain that it's thin (about 1/8-inch diameter). Twist and tin the shield, and strip the center conductor insulation within 1/4-inch to 3/8-inch of the shield. Locate the video-input wire to the TV module and tack-solder the cable shield to the ground foil directly under the module's video-input wire. Carefully cut away all excess strands of shield wire to ensure they don't short to adjacent foil, then wrap the cable's center conductor around the module's video input and solder.

Flip the circuit board over, route the cable to the phono jack, and cut it to length. Be certain that your routing will not cause the cable to interfere with re-installing the circuit board. If necessary, you can snake the wire around the plastic supports sticking up from the cabinet. Again, prepare the free end of the coaxial cable, then connect it to the phono jack. Finally, secure the circuit board with its two screws, install

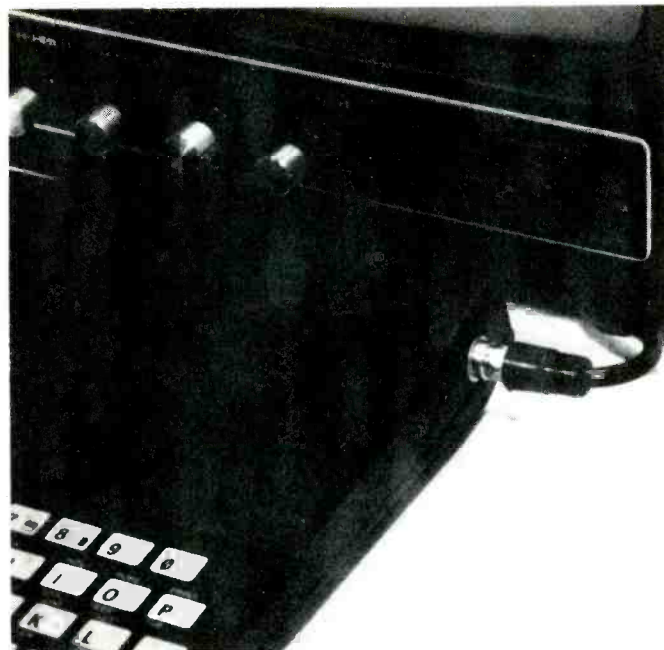

▲ FIG. 7—TO CONNECT THE COMPUTER to a video monitor, simply plug a shielded or coaxial cable into the new video jack on the right side of the computer.

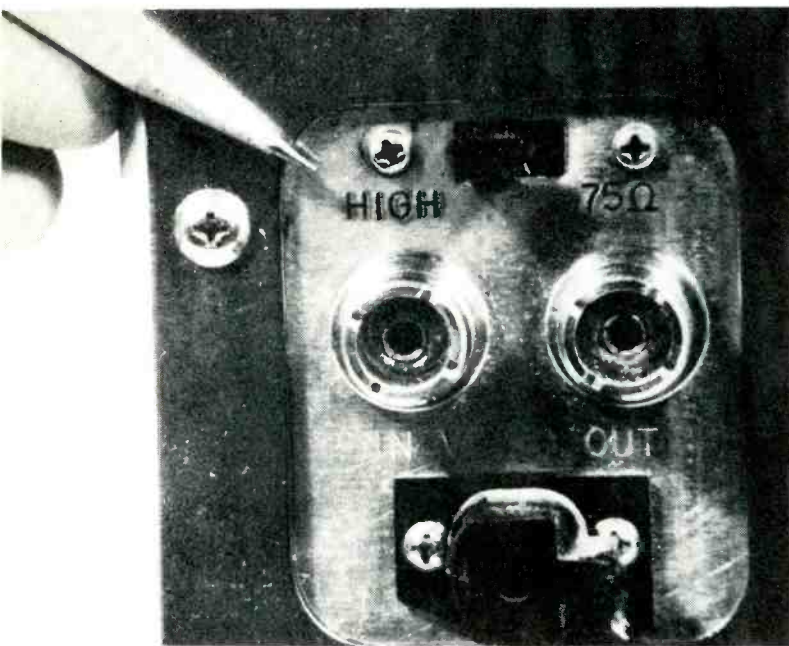

◀ FIG. 8—MOST VIDEO MONITORS have both 75-ohm and a high-impedance (nominally 1 Megohm) inputs; a selector switch determines the input impedance. For the ZX/81 and Timex computers use the HIGH-Z input.

FIG. 9. Here's the modified Sinclair/Timex Computer interconnected (computer buffs like to use "interface") with a video monitor—void of an RF front end. Picture clarity is razor sharp and is void of all the noise and interference when using a TV modulator.

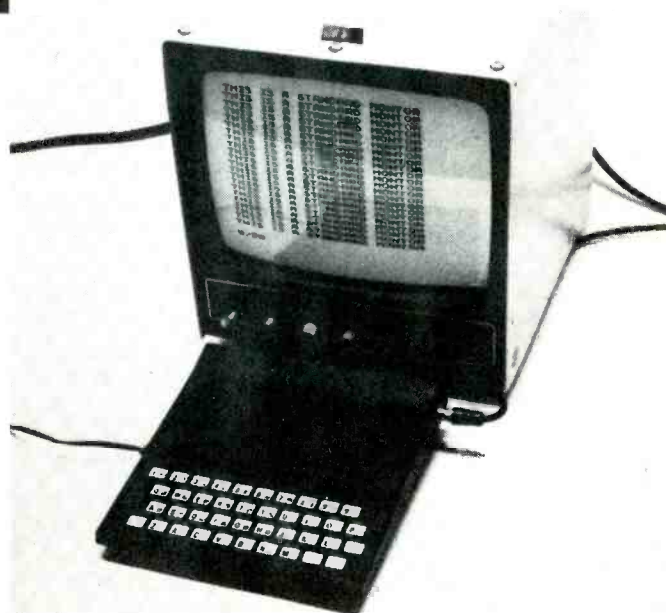

the cabinet cover, secure the five mounting screws, then place a dab of fast-drying adhesive or rubber cement on the feet and secure in place. Fig. 7 shows how the installation will appear when you plug in the cable from the monitor.

### Using a video monitor

Most video monitors have switch-selected 75 ohm (low-Z) and high-Z (about 1 Megohm) inputs. See Figs. 8 and 9. The Sinclair/Timex computer doesn't have sufficient output to drive both its modulator and a video monitor to "best picture", so set the video-monitor switch to HIGH-Z, or whatever designation is used for the high-impedance input. That's the total extent of your adjustment.

Both the TV monitor and video computer outputs will be available, and you select the one you want by simply plugging the phono-jack patch cord into the appropriate jack. You plug into the original TV modulator phono jack if you're using a standard TV receiver for the monitor. If you plug into the jack you just installed, you use a standard high-Z video monitor.

SP

# Electronic Flasher

**Remove the “stone-age” thermo-mechanical signal flasher from your car and add a beeping, solid-state device whose flash frequency is always constant!**

TERRY A. WARD

THIS ELECTRONIC FLASHER CIRCUIT IS A SOLID-STATE REPLACEMENT for the thermo-mechanical turn-signal flashers used in almost all automobiles. Thermo-mechanical turn-signal flashers have several disadvantages which may be dangerous to the car and passengers. The speed at which the turn-signal lamps flash is affected both by changes in the car's charging-system voltage and by changes in flasher load current. The higher the voltage or current through the flasher, the faster the turn-signal lamps will flash.

The opposite is also true! For instance, on a cold winter night, engine idling with lights, heater, and other accessories on, the charging system's voltage may be very low. Under those conditions the turn-signal lamps may flash too slowly—or not at all.

Another example would be in the case where a trailer's turn signals are wired to the car's signals. Current draw may increase to a point that the turn signals flash so quickly they appear to be about half-brightness constantly. You see, the lamps have a thermal lag. Another disadvantage to thermo-mechanical flashers is that many times the clicking of the flasher may not be heard over the road noise. That may cause the turn signals to be left on accidentally for several miles after the driver makes a turn or lane change. Those can be very dangerous situations.

The solid-state, turn-signal Electronic Flasher described in this article has none of the disadvantages mentioned above. The flashing speed of the unit will not change unless the input voltage drops below about 7 volts, in which case the car will not start anyway, nor would it run in all probability. The circuit will drive from 1 to 7 signal lamps per side, which makes it ideal for trailer towing or add-on lamps for vans. It also provides a warning tone when the turn signals are on, instead of the sometimes inaudible clicking. Turn-signal flashing speed and the frequency and volume of the warning tone may be adjusted to suit your particular taste. The circuit is designed to replace two-terminal, turn-signal flashers only, which are used in about 90 percent of the cars on the road today.

The Electronic Flasher *cannot* be used in cars with 6-volt electrical systems or in cars with a positive ground, both of which were not used in most cars after the 1950's. The Electronic Flasher also *should not* be used to replace 4-way emergency flashers, because parts of the circuit are on whenever voltage is applied.

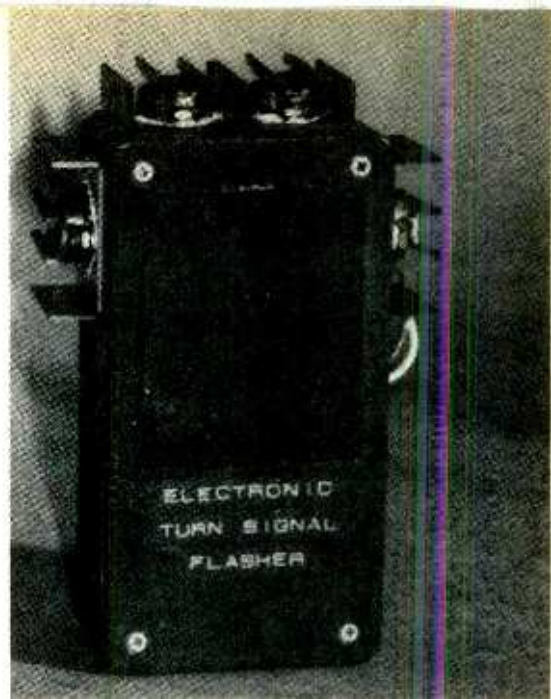

## About the circuit

Voltage regulation for the circuit is provided by 5-volt regulator chip, IC1. Diode D1 helps protect the circuit against reverse-voltage spikes generated by turning off inductive devices such as starter motors and alternator kick-back when the ignition is turned off. C1 and C2 filter the input and output voltages, respectively, and also improve the stability of IC1.

The turn-signal lamp on/off timing signal and the turn-signal on warning tone are both produced by IC2, a 556 dual timer chip. R1, R2, and C3 are timing components that set the turn-signal lamp flashing speed. The flashing speed can be changed to suit your needs by changing the value of R1 and R2. The formula for doing that is shown in Table A. R3, R4, R5, and C4 are timing components that set the frequency of the turn-signal on warning tone. The warning-tone frequency may be adjusted between 72 Hz and 10.8 KHz by potentiometer R5. C5 and C6 help keep the 556 timer IC2 stable in the harsh, electrically-noisy environment.

The turn-signal on warning-tone output from IC2 pin 5 is sent through diode D2, which blocks any voltage that may be fed back through the loud speaker, SPKR. R6 limits the current that can be drawn from IC2 and potentiometer R7 will adjust the turn-signal on warning-tone volume to an acceptable level. The speaker is a small 1.5-in., 8-ohm speaker, which will provide more than enough volume for most applications. The return line of the speaker, SPKR, is connected to the emitters of Q5 through Q8. Ground is provided to SPKR through the signal lamps *only* when the turn-signal switch in the car is on (left or right) and only during the off cycle of the flasher, when Q5, Q6, Q7, and Q8 are not conducting. That configuration provides an alternating on-and-off warning-tone *only* when the turn signals are on. IC2, pin 9 is the turn-signal lamp flasher output, which is connected to IC3, an LM339 quad voltage comparator at its inverting inputs, pins 4, 6, 8 and 10. Resistors R8 and R9 form a voltage divider that provides a 2.5-volt reference to the non-inverting inputs of IC3, pins 5, 7, 9 and 11. In that configuration, IC3 inverts the input signal from IC2, pin 9. IC3 also splits the input signal into four outputs and converts the TTL input levels to the voltage levels needed by the output transistors to turn the signal lamps fully on and off—0 and +12 VDC. The outputs from IC3, pins 1, 2, 13, and 14



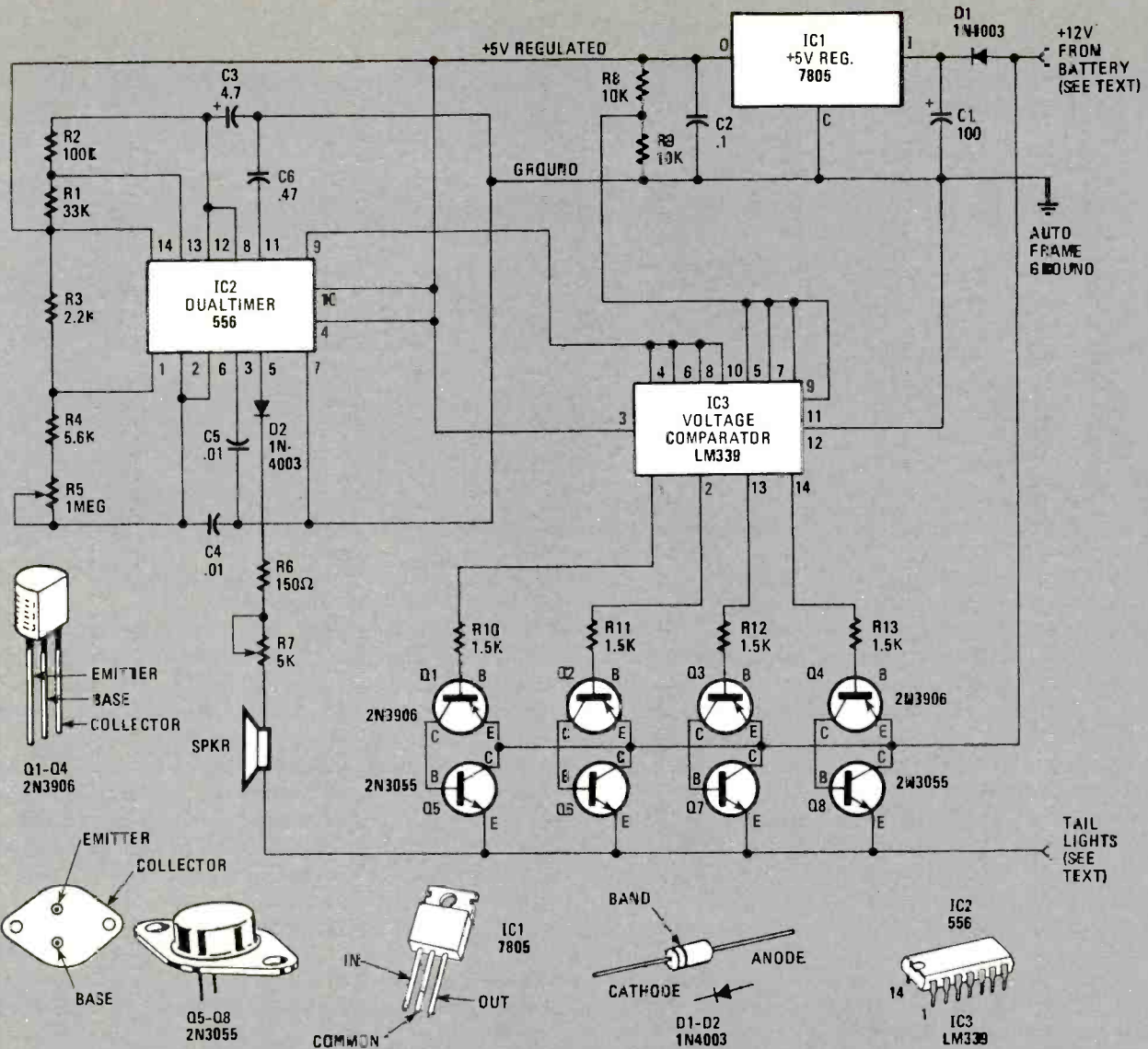

FIG. 1—SCHEMATIC DIAGRAM FOR THE ELECTRONIC FLASHER uses several semiconductors packaged in five different-type cases or moldings. The dual 556 timer, IC2, determine the turn-signal on and off periods. Circuit constants determine exact periods as stated in Table A. The quad voltage comparator, IC3, has all its non-inverting inputs tied to the 2.5-volt DC tap at R8 and R9. As the squarewaves from IC2, pin 9 arrive at the inverting inputs (all tied together) the quad sections switch on and off, swiftly controlling four sets of 2N3906/2N3055 high-current switching circuits paralleled at the output terminal for the maximum switching capacity that is required for automobiles with trailer hooks.

are connected to resistors 10, 11, 12, and 13 respectively. Those resistors limit the base current to transistor Q1, Q2, Q3, and Q4. Transistors Q1 through Q4 combined with Q5 through Q8 respectively forming four Darlington pairs. The emitters of transistors Q5 through Q8 are connected together to increase the current-handling capability of the Electronic Flasher, and form the output of the Electronic Flasher, which is used to drive the turn-signal lamps of the car.

### Construction and operation

The circuit can be constructed on a prototype grid board (perfboard) using point-to-point wiring. Plan to keep the unit's size small since the space behind most dashboards is very cramped. The circuit layout is not critical. Transistors Q5, Q6, Q7, and Q8 should be mounted on heat sinks because most cars' turn signals draw a lot of current. The Vin and the output wires (use No. 12 AWG) from the project

should have 1/4-in. spade plugs on the ends. That will allow you to install the project in your car by simply plugging it in to the car's flasher socket; no cutting or splicing to your car's wiring will be needed. In some cars, the flasher plugs into the fuse panel, so use a burned-out fuse to terminate the wires.

To install the Electronic Flasher, three connections must be made to the automobile. Two connections will be made to the automobile's turn-signal flasher socket, and the third will be made to the car's electrical ground. First make sure that the car is in gear, or in park, with the emergency brake on and the ignition switch in the *off* position. Remove the turn-signal flasher from its socket. Turn the ignition switch to the *on* position, but *do not start* the engine. Move the turn-signal lever to either the right- or left-turn position. The turn signals should not be functioning; if they are, the 4-way hazard flasher has been removed and not the turn-signal flasher. With a VOM find which one of the car's flasher socket

## PARTS LIST FOR ELECTRONIC FLASHER

### SEMICONDUCTORS

D1, D2—1N4003 silicon rectifier diode  
 IC1—7805 +5-volt DC regulator integrated circuit  
 IC2—555 Dual timer integrated circuit  
 IC3—LM339 quad low-power, low-offset, voltage comparator integrated circuit silicon  
 Q1-Q4—2N3906 silicon switching and amplifier transistor  
 Q5-Q8—2N3055 silicon high-power transistor, 15 amperes, 115 watts

### RESISTORS

All resistors are 1/2-watt, 5% values unless otherwise specified

R1—33,000-ohm  
 R2—100,000-ohm  
 R3—2200-ohm  
 R4—5600-ohm

R5—1-Megohm potentiometer, PC-board mount  
 R6—150-ohm  
 R7—5000-ohm potentiometer, PC-board mount  
 R8, R9—10,000-ohm  
 R10-R13—1500-ohm

### CAPACITORS

C1—100- $\mu$ F, 35-WVDC electrolytic  
 C2—.1- $\mu$ F ceramic  
 C3—4.7- $\mu$ F, 15-WVDC electrolytic  
 C4, C5—.01- $\mu$ F ceramic  
 C6—.47- $\mu$ F, metal-film

### ADDITIONAL PARTS AND MATERIALS

SPKR—1 1/2-in. diameter speaker, 8-10-ohm  
 Plastic case, heat sinks to handle 35-50 watts total, perfboard, RV cement, hardware, wire, solder, etc.

terminals is at +12 volts DC. Turn the ignition switch *off* before making any connections to the automobile. The project's Vin wire will plug into that terminal. The output wire from the project will plug into the remaining terminal. The third and last wire from the project is a ground and may be connected to any metal part common to the negative terminal of the battery, support braces, etc. Make sure the device is mounted so that the transistor cases and heat sinks for Q5-Q8 don't touch any metal parts in the car. If they do, you'll blow the +12-volt fuse to the turn-signal line. After the project has been installed, turn on the turn-signals and make sure that all the car's signal lamps operate properly.

Set the frequency and volume of the turn-signal on warning tone by adjusting R5 and R7, respectively. If you wish to change the flasher speed, the values of R1 and R2 must be changed on the workbench and not in the car. The formulas to do that are listed in Table A. With the values of R1 and R2 shown in the schematic diagram (Fig. 1), the flasher speed

will be: 1 cycle = .75 seconds, signal lamps off .32 seconds, and signal lamps on .43 seconds.

The Electronic Flasher, unlike thermo-mechanical flashers, is not dependent on a number of lamps to continue operating. Thermo-mechanical flashers stop operation after one or two lamps burn out, thus warning the driver of the lamp failure, but leaving him without turn signals. The Electronic Flasher will stop operating only if *all* the signal lamps on one side are burned out, including the direction indicator in the dash panel and then *only* on that side. It is very important that *all* signal lamps be checked periodically for proper operation, as well as the brake lights, emergency-warning lights, side-marker lights, etc. Burned-out lamps should be replaced immediately. Throughout North America, you will receive a summons for a moving violation should you drive your car on a street or highway with improper lights. Let the local yokel chase speeders and light jumpers.

SP

TABLE A  
 ELECTRONIC FLASHER TIME CONSTANTS

Time for one cycle in seconds	= .685 (R1 + 2R2) C3
Turn lamps on in seconds	= .685 (R1 + R2) C3
Turn lamps off in seconds	= .685 (R2) C3
Where R1 and R2 are in Megohms, and C3 is in microFarads	

#### Example

When R1 is 33K and R2 is 100K, and C3 is 4.7- $\mu$ F:

Then: R1 = .033 Megohms  
 R2 = .100 Megohms  
 C3 = 4.7  $\mu$ F

Time for one cycle in seconds =  
 $.685 \times .233 \times 4.7 = .750$  second

Turn lamps on in seconds =  
 $.685 \times .133 \times 4.7 = .428$  second

Turn lamps off in seconds =  
 $.685 \times .100 \times 4.7 = .322$  second

WITH THE COVER REMOVED you can easily notice the simple packaging technique to assemble the unit. Any packaging technique is usable, providing that the space available under the dashboard is sufficient. Instead of using four heat sinks, you may use two— or one big one. That all depends on the design you come up with.

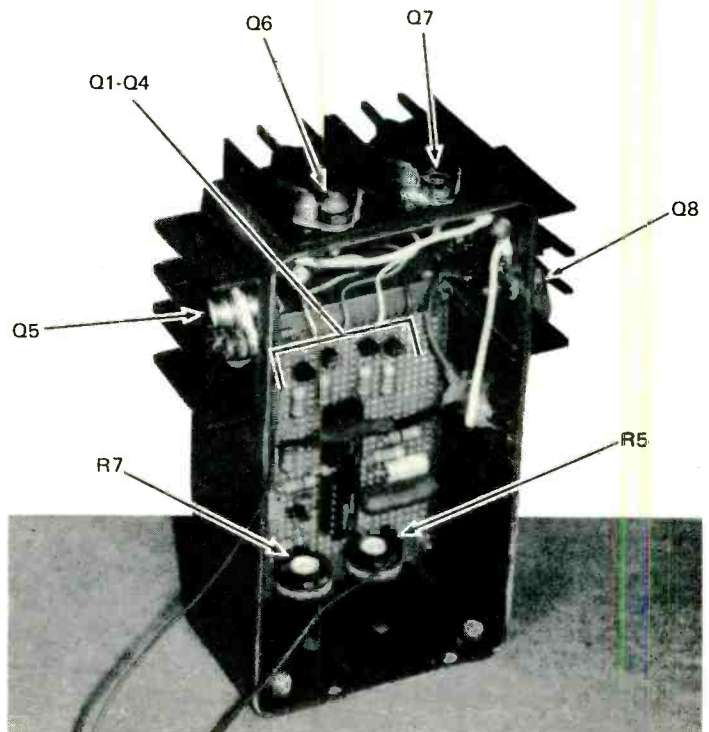

***The romance of a flame  
whether it be a she or a candle  
can be heated up  
with this electronic taper***

# SYNDLE

RICHARD L. SCHUH

THE FLICKERING LIGHT OF A CANDLE FLAME HAS FASCINATED man throughout the centuries, and has illuminated the darkness in a thousand different forms. However, despite major advances in technology, the candle has somehow managed to keep its basic form: it exists virtually unchanged in today's world of VLSI and synthetic sound, and will probably remain so for some time to come. The primary function has changed, however, and today the candle finds far greater use as a decoration than as a practical method of illumination.

Although it may be difficult to surpass as an interesting tablepiece, the traditional candle has a few disadvantages when applied to many applications. Commercially, even when overlooking the potential danger of an open flame, the associated insurance risks and tedious maintenance requirements, the simple cost of candlelight is surprisingly high. A restaurant may easily use \$50.00 worth of candles per year at every table simply to insure that the proper atmosphere exists. The same susceptibility to moving air currents that gives the candle its charm and warmth makes it somewhat less than totally reliable in windy environments, a fact that movie makers have exploited for years. How many times has a faintly flickering point of light been coughed into nothingness by a well-timed draft, leaving our horror movie hero/heroine frantically fumbling for that elusive last match.

The circuit described in this article does away with those problems by substituting a low-voltage filament for a flame, and electronics for the effects of the surrounding atmosphere. The result is attention getting, hypnotic, and fascinating. Once built, Syndle can eliminate the difficulties of replacing burned-out candles and nursing faint-hearted flames forever. Filmmakers take heart; however, the batteries could still fail!

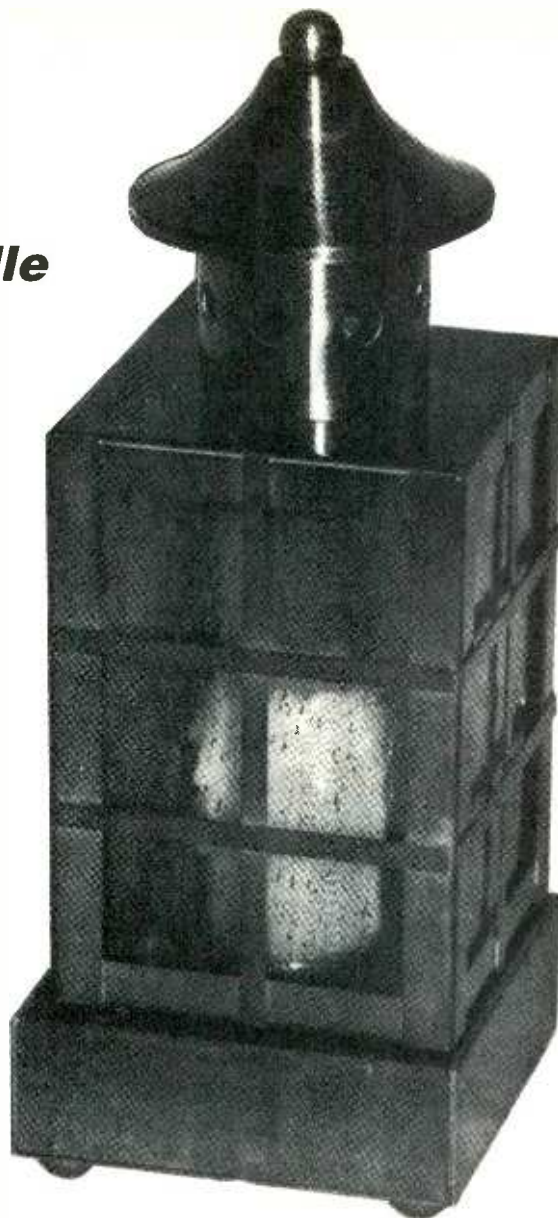

## About the Circuit

IC3, a 555 timer chip, (see Fig.1) is configured as an astable multivibrator operating at a nominal frequency of 4 Hz with its output directly driving a #1850 incandescent lamp I1. IC1 and IC2 are similar astable multivibrators operating at much lower frequencies, typically .03 and .04 Hz respectively. The pulse waveform produced by IC1 is integrated by R7/C9 and buffered by one section of IC4. The resulting ramp is applied to the timing network of IC3 via D3 and R11, altering the latter's output frequency and duty cycle. Pulses produced by IC2 are similarly integrated by R8/C6 and further vary IC3's duty cycle by means of pulse-width modulation via pin 5. The interaction of the two control signals provides a random, continuously varying pulse train which modulates the intensity of I1. Due to the thermal hysteresis inherent in the lamp, this random series of pulses is smoothed, resulting in a flickering effect which continually varies from a subtle undulation to occasional deep pulsations and dimming effects, giving the impression of a flame disturbed by air currents. The overall effect can be tailored to suit individual tastes by altering the time constants of any or all R/C networks associated with the circuit; however, R5 and C8 affect the character of the flicker most directly and should be selected to give the desired effect.

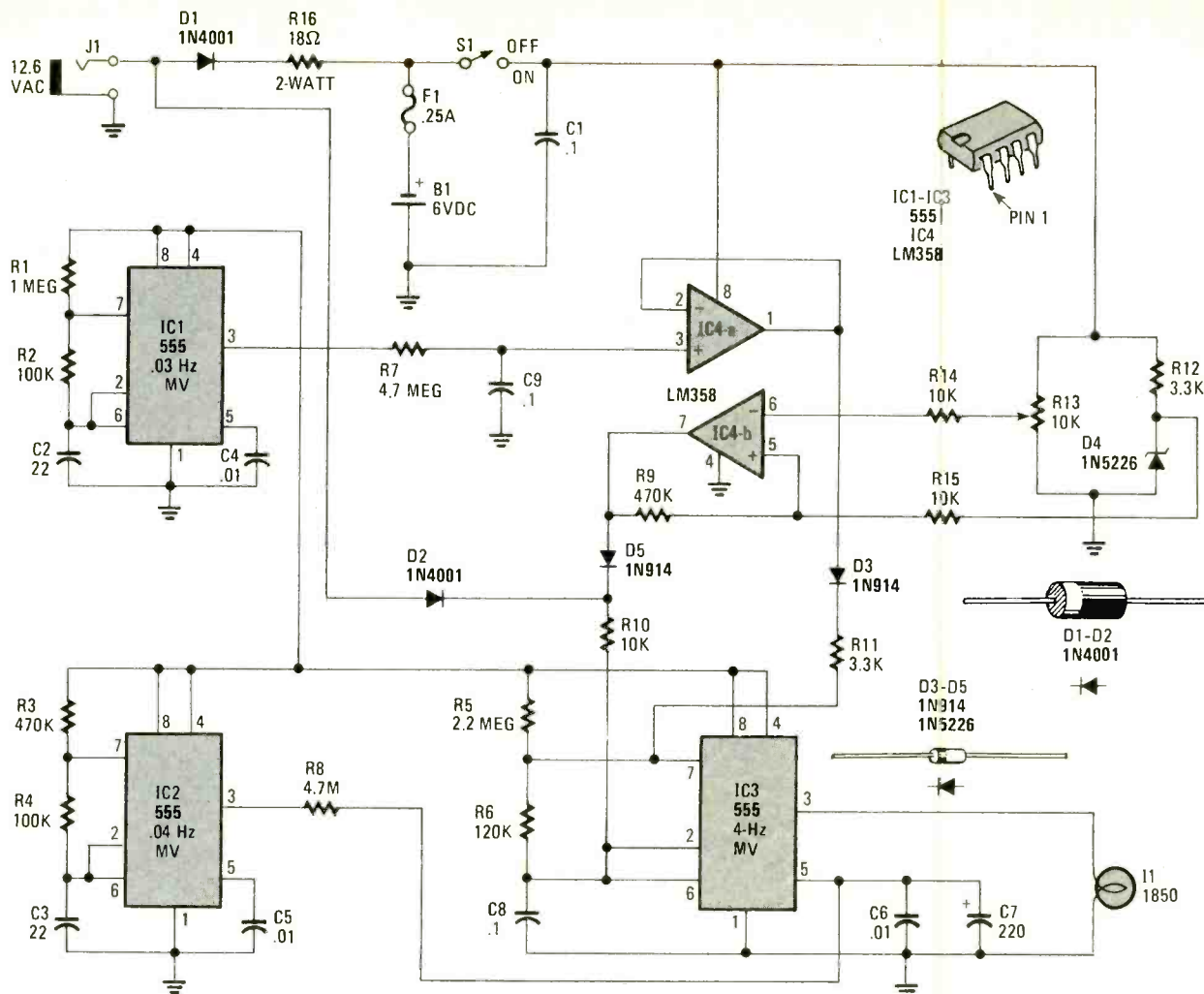

FIG. 1—HERE'S A DIAGRAM that has timer on its hands! Three 555 timer chips are used to flicker-control a lamp bulb with frequencies of .03 Hz, and .04 Hz. Put them all together, they spell flickering-light—the mystique of Syndle, the electronic candle.

The second section of IC4 (see Fig. 1) is used as a comparator monitoring the supply voltage and inhibiting IC3 when the battery voltage drops below a pre-set value, forestalling the complete discharge of B1. Zener diode D4 provides a stable reference voltage for the comparators non-inverting input, while a portion of the battery voltage is applied to the inverting input via trimmer potentiometer R14

allowing the trip point to be set at the "knee" of the NiCd battery's discharge curve. When the supply voltage drops below a preset point, IC4's output goes high, driving the threshold comparator of IC3 high via R10 and causing the output to go low, extinguishing I1 and reducing current demand to a few mA. Hysteresis provided by R19 prevents I1 from cycling on and off as the supply voltage fluctuates slightly with current demand. Diode D5 isolates the output of IC4 from the timing network of IC3 when the supply voltage is normal and the output of the comparator is low.

Optional NiCd battery B1 (see Fig. 1) is slow-charged via D1 and R16 at approximately 1/10 of its normal discharge rate and will recharge completely within 10 to 14 hours. During recharging, current flowing through D2 and R10 drives IC3's threshold comparator high, extinguishing I1, preventing unnecessary current drain and decreasing the charging time.

An optional power switch, S1 can be included if it is desired to store Syndle for a period of time. Current drain averages less than 100 mA when the device is operating, so battery life should be approximately 12 hours when using a 1.2 ampere-hour battery.

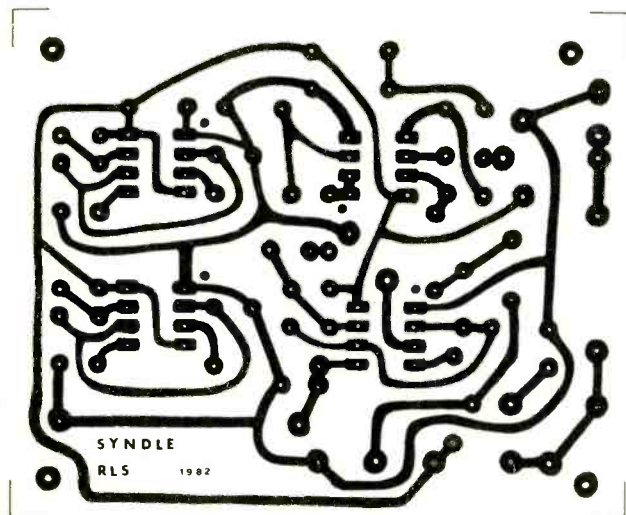

FIG. 2—SYNDLE'S CIRCUIT BOARD is designed with the novice in mind. Heavy copper-foil paths can take a bit more soldering iron heat than can the fineline layouts.

## PARTS LIST FOR SYNDLE

### SEMICONDUCTORS

D1, D2—1N4001 50-V PRV, 1-A Silicon rectifier  
D3, D5—1N914 silicon switching diode  
D4—1N5226 3.3-V, 1/2-watt silicon Zener diode  
IC1-IC3—NE555V timer integrated circuit  
IC4—LM358 low-power dual operational amplifier

### RESISTORS

All resistors are 1/4-watt, composition, 5% types unless otherwise specified.

R1—1-Megohm  
R2, R4—100,000-ohm  
R3, R9—470,000-ohm  
R5—2.2-Megohm  
R6—120,000-ohm  
R7, R8—4.7-Megohm  
R10, R14, R15—10,000-ohm  
R11, R12—3300-ohm  
R13—10,000-ohm, PC mount, trimmer potentiometer  
R16—18-ohm, 2-watt, 5% wire-wound resistor

### CAPACITORS

C1, C9—.1- $\mu$ f, 50-WVDC ceramic  
C2, C3—22- $\mu$ f, 12-WVDC electrolytic  
C4, C5, C6—.01- $\mu$ f, 50-WVDC ceramic

C7—220- $\mu$ f, 12-WVDC electrolytic  
C8—.1- $\mu$ f, 100-WVDC Mylar

### ADDITIONAL PARTS AND MATERIALS

B1—6-VDC, 1.2 AH, NiCd battery  
F1—.25-A 3AG fuse  
I1—No. 1850 lamp bulb, see text  
J1—Miniature open-circuit jack  
P1—Miniature plug to mate with J1  
S1—SPST, miniature, toggle switch  
T1—117-VAC pri. to 12.6-VAC, 250mA transformer; Jimpak (AC and NiCd power versions) type AC250 or equivalent  
Printed-circuit board materials, fuse clips (2), socket for I1, wire, mounting hardware, enclosure, hardware, solder, etc.

The following are available from Hiawatha Electronics, Inc., P.O. Box 442, Winona, MN 55987:

Circuit board and all parts which mount on board—\$24.95 postpaid USA.

Circuit board only—\$9.00 postpaid USA.

Please include applicable state and local sales taxes.

Fuse F1 protects the device from damage that could be caused by the potentially large current that B1 can supply, due to its low internal resistance. While the author chose to utilize a NiCd battery pack in the prototype, other types of cells are available and offer advantages in many cases. Gelled electrolyte batteries such as Panasonics #6M1.2 offer high current capabilities, and freedom from the memory effect that plagues NiCds. Those batteries may require alteration of the charging circuit however to insure that they receive the proper current.

### Putting it together

Construction is not critical as there are no high frequencies involved and perfboard, wirewrap, and printed circuit board construction methods are acceptable. Following the

PC-board pattern shown in Fig. 2 results in a neat, functional project, and greatly reduces the chance of a wiring error. I1 can be mounted directly to the board, if desired, by using a PC-board socket, or may be remotely located to facilitate mounting the electronics in prefabricated housings. All other components, with the exception of B1, S1, and J1 mount directly to the board. Refer to Fig. 3.

Begin construction by installing all required jumpers on the PC-board, including J2 if the switch is to be omitted. Follow by mounting the diodes, resistors, and capacitors, observing polarity where important. Note that some resistors are mounted vertically to conserve space. The IC's should be mounted last, along with trimmer R13 and the fuse clips.

Four wires may be connected to facilitate connecting the completed board to the battery and charger jack, with a fifth wire required if it is desired to mount I1 external to the assembly. The board can be mounted on standoffs or held in place by double-sided foam tape. The latter method is often used by manufacturers of small circuit-board accessories that are designed to be mounted in commercial communications equipment, where a wide variety of installation variations may be encountered.

### Dress it up

The electronics completed, the builder must ponder the nature of the enclosure used to house Syndle. Such enclosures may be as simple as a plexiglass pyramid build around the circuit board, or as ornate as desired. The author chose to

PEEK INSIDE THE BASE of Syndle and you'll see the printed-circuit board mounted on two brass standoffs leaving room to mount or stuff the batteries, too! Be sure to tape all exposed metal parts on the batteries to avoid an accidental short circuit. The foam pad glued to the inside base cover at right presses against the batteries holding them in place. Note the on/off switch and battery-charger jack also mounted on the base cover. Once assembled, Syndle looks like the old-fashioned candle holder Grandma used.

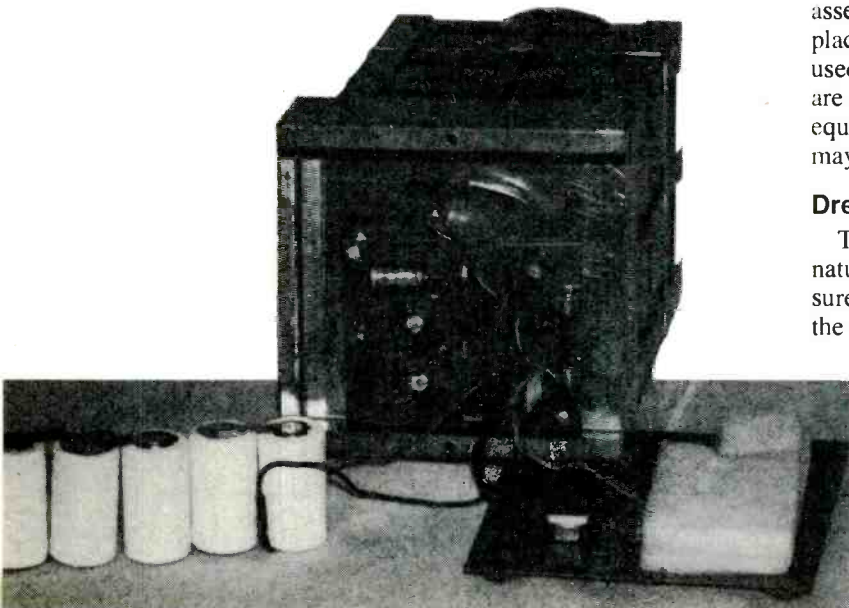
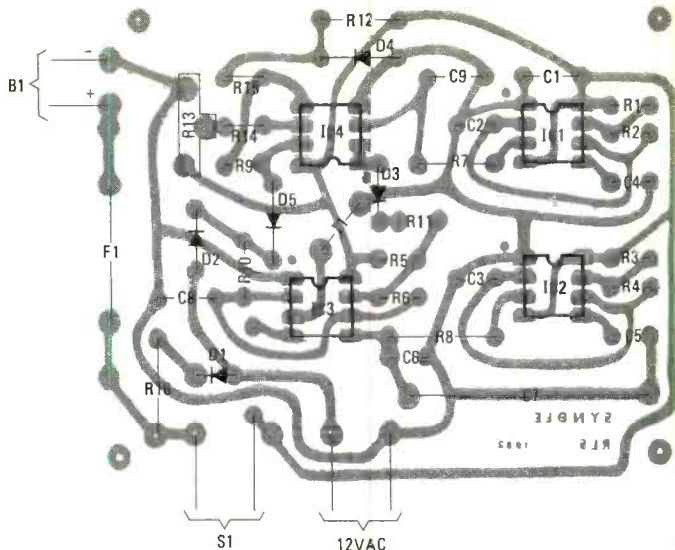

**FIG. 3—PARTS PLACEMENT** looks simple enough until you try to mount a resistor with its axis parallel to the surface of the board. That cannot be done in some cases because the holes are too close together. Then do as the pros do—mount the resistor with its axis perpendicular to the board's surface and bend the top-most lead to the mating mounting hole.

build the prototype using a plastic simulated candle mounted in a decorative table lamp typical of those found in restaurants. See photos. The battery and electronics are mounted in the base, along with S1 and J1. The resulting combination presents a very realistic effect. Similar lamps may be found in gift shops or hardware stores; however, careful selection is necessary if it is desired to fit all the components within the case.

With the exception of R13, there are no adjustments required to cause the circuit to operate. Connect a variable power supply in place of the battery, with the voltage set to approximately 6 volts and adjust R13 fully clockwise. The lamp should light and begin to flicker. Verify the random nature of the flickering by observing the device's operation for a few moments.

The proper functioning of IC1, IC2, and IC3 can be checked by monitoring the output of each device individually. A voltmeter or oscilloscope connected between pin 3 and ground will show a pulse of several second's duration occurring every 20 to 40 seconds at IC1 and IC2. IC3 will exhibit a continuously varying pulse train of approximately 4 Hz. If improper operation is observed, check the wiring and component placement for the affected stage.



After determining that Syndle is functioning properly, reduce the power-supply voltage slowly until the lamp is extinguished. Note the power supply voltage. It should be very close to 5.6 volts. If it is not, increase the voltage to again light the lamp, readjust the setting of R13 up or down as required, and repeat the process until the lamp goes out as the decreasing voltage reaches 5.6 volts. Due to the hysteresis in the comparator circuit, the voltage level needed to turn the lamp on will be higher than that at which it switches off. Once properly adjusted, the trimpot can be fixed in place with a drop of nail polish and should require no further adjustment. If a 47-type bulb is used in place of the 1850, B1 should have a potential of 7.2 volts (6 cells) and the proper turn off voltage would then be 6.5 volts.

#### A non-electronic note

During the course of experimenting with Syndle, the author discovered a few pertinent facts about its operation. When altering component values to obtain the desired flicker, look slightly away from I1; do not look at it, because your peripheral vision is more sensitive to small changes in light intensity than when looking towards the light source directly. That is due to the greater number of rods (light-sensitive cells) in that portion of the eye. Surrounding the lamp with a translucent material such as frosted plexiglass, paper, or plastic greatly accentuates the flickering effect, due mainly to the light scattering caused by the nature of these materials.

The Syndle can be used in a variety of applications, such as a substitute for a candle in the home or restaurant, as a Christmas decoration, or as a safe, portable source of illumination for a Jack O' Lantern. As a locating beacon for your car, it is unique and easily spotted at night. If left plugged into its charger continuously (its slow charging rate won't overcharge B1), it will light immediately should the power fail. AC-powered versions (which require transformer T1) may be adapted to outdoor lights or doorbell-button illuminators. Other applications will undoubtedly occur to the reader just as countless uses have already been discovered for the candle.

**SP**

**HERE'S SYNDLE** before it is buttoned up. Note the #1850 lamp bulb set low in a plastic candle sleeve which is designed to slip over a standard light socket. Make your connections inside the socket to the lamp and circuit board mounted in the base of the brass lamp fixture. Neatness counts for impact when unit is completed.

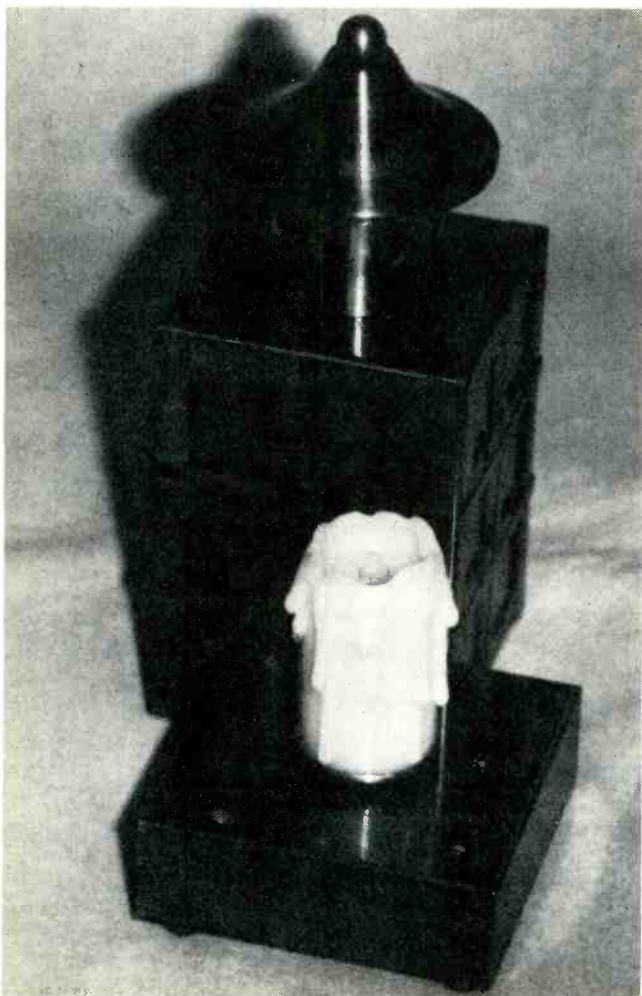

# JBL SYSTEM

***Here are full construction details for a loudspeaker system especially designed for professional musicians. Husky and efficient, this 300-watt project is particularly suitable for use with lead guitars and electronic keyboards.***

NEVILLE WILLIAMS

WHEN THE LADY OF THE HOUSE WANTS TO DUST UNDER THE rafters, what do you do? You lift the roof! That may be easy to do, provided you are a musician and have need for a 300-watt home-made loudspeaker enclosure. To help you out with the housework and your musical performance, we are providing the complete plans for the Just Blast Loudspeaker System, or, as we call it for short—JBL System. As a matter of fact, the JBL System uses the JBL E130 bass/middle-range driver which has a continuous power rating of 300-watts and a sensitivity of 105 dB. The optional treble driver packs solid oomph also, but more on that later.

The E130 is fitted with a metal cap over the voice coil, which sustains the response to a nominal 6 kHz. JBL says that it (is commonly) used on its own for lead guitar, vocals, and keyboards. Where there is a requirement for a more prominent upper register, one or more separate tweeter loudspeakers can be used. But they must be of a type with sensitivity and power handling to match that of the E130; otherwise, they would be completely useless. More about that point later.

But why the distinction ... vocal, lead guitars, keyboards? Surely a good system should be good for anything—hi-fi, guitars, electric pianos, organs, public-address systems, and what have you! It's a point that may puzzle hi-fi fans and one that warrants clarification.

The long and the short of it is that there are important distinctions between optimised hi-fi and optimised "music"

loudspeakers, involving such qualities as frequency response, distortion sensitivity, and overload characteristic. A loudspeaker intended for a hi-fi system has to be capable of reproducing a wide variety of sound, from the deepest notes of a grand organ to the shimmering near-supersonics of a cymbal. It should have no obvious peaks or troughs in its frequency response; otherwise it will impart its own coloration to instrumental or vocal sound. Distortion must also be as low as possible at all likely power levels, from a whisper to full volume in the particular listening situation—almost invariably a home environment.

## **About hi-fi loudspeakers**

To meet those needs, designers of hi-fi loudspeakers have tended to favor the use of voice coils much longer than the magnetic gap, such that a fixed number of turns remains in the gap, even during extensive cone excursions. The method provides good linear cone drive and accords with compact enclosure design, but it markedly reduces sensitivity, thereby necessitating considerable audio-drive power.

For that reason, domestic hi-fi amplifiers are more likely these days to be in the 25- to 100-watt per-channel class than 5- 20-watts. In short, sensitivity is sacrificed in the knowledge that extra drive power (in that range, anyway) can be secured without too much hassle. Nor does a hi-fi loudspeaker manufacturer have to worry unduly about overload. With the onset of overload distortion, most hi-fi listeners will react automatically and turn down the volume before damage occurs to the voice coil.

A specialized "music" loudspeaker system differs from

\*Original project appeared in *Electronics Australia*, January, 1981 Edition, and reappears here by permission.

the foregoing on almost every count. Consider, for example, the matter of frequency response: A music speaker is not required to reproduce the sound of all instruments but only that of one type. Needs vary with the type of instrument, as the following examples should indicate

*Church or classical electronic organ:* Bass should be well sustained down to 32 Hz, middles smooth, upper treble tapered off to minimize risk of the instrument sounding too "reedy."

*Popular electronic organ:* For theater-style recitals, much the same as for a classical organ. For group work or a "zingy" solo sound, more sustained treble is desirable, but a bass roll-off at 50 Hz might be acceptable.



**THE E130 DRIVER is a large and heavy loudspeaker requiring a 14-inch diameter cutout. The metal dome cap is not just decorative; it holds the frequency response to about 6 kHz. The driver is available in 4, 8, and 16-ohm versions. The 2901A treble power pack is compatible with all three.**

*Bass guitar:* Bass sustained to about 40 Hz, treble response not important above 2500 Hz.

*Hawaiian steel guitar:* Bass sustained to about 50 Hz, treble: about 5000 Hz.

*Lead and rhythm guitar:* Bass sustained to about 50 Hz; strong middle response, 6000 Hz at least.

*Electric piano:* Broadly similar requirements to lead and rhythm guitar, above.

If a brighter than average sound is required, the response can be extended to 10,000 Hz or more by the addition of one or more tweeters having an appropriate power rating. Thus

voice vocals can be reproduced with a smooth response from 50 to about 7000 Hz. The setup can be a system like that for lead guitar or electric piano, provided that the middle and treble is not too peaky, rendering the voice harsh or sibilant.

Looking at those requirements, it is evident that the loud-speaker system for a recital organ or bass guitar must have a fundamental response down to the 30-40 Hz region, combined with the ability to generate acoustic power appropriate to the environment. For large auditoriums it adds up to one or more powerful bass drivers, a bulky enclosure, and a power amplifier with an appropriate output rating.

To meet that specific need, JBL offers a number of specialist bass drivers, of which the E140 is typical. With a diameter of 15 inches, it has a nominal frequency response from 40-2500 Hz and a power rating of 200-watts RMS continuous tone, or 400-watts continuous program. For a bass guitarist, it could probably be used alone, but for a recital organ it would have to be supplemented by adequately rated drivers covering the mid- and upper-range.

For all other applications, it is evident that the bottom octave can be compromised, if not sacrificed, and that has important implications. The driver-cone suspension can be stiffened, raising the natural system resonance to around 50-60 Hz, and a more compact enclosure can be designed around those new parameters. While such a system will still produce plenty of output from low-frequency drive, it will tend to be less "fundamental" in its quality. It will also absorb a lot of punishment.

A driver reflecting that philosophy is the one which forms the basis of the JBL System, the JBL E130. Also a 15-inch type with a 4-inch voice coil, it has a nominal frequency range of 50-6000 Hz and a power rating of 150-watts continuous tone or 300-watts continuous program. The fact that fundamental output is not required below about 50 Hz has another important implication: Cone travel will be less, the voice coil can be shorter (hence more of it in the magnetic gap), and efficiency can be improved.

With its high sensitivity and power rating, the JBL E130 driver can place enormous stresses on an enclosure when operating at full power. Everything needs to be solidly cleated, glued, and screwed, with front-to-back braces for good measure. Anything less firmly constructed may not withstand the stresses of being trucked and manhandled off-stage by roadies, and violently "pumped" on-stage. Many groups have experienced their loudspeaker cabinets literally coming apart at the seams, with the rear panel being particularly vulnerable.

### Nature of drive

The 300-watt program rating for the E130 assumes clean drive. Consider one of the hazards for stage loudspeakers: amplifiers which are inadequate for the job in hand and which are operated into overload by overenthusiastic musicians. If the peaks are squashed into squarewaves and the "softer" passages exaggerated, the heat load on the voice coil can reach destructive limits.

In effect, the use of a 300-watt amplifier does not give automatic protection for a 300-watt loudspeaker. If the amplifier is abused and overloaded, so also will be the loudspeaker. While the natural response of the E130 is quite reasonable for a high power driver—nominally to 6000 Hz—it needs reinforcement at the top end for a deliberately bright sound. The problem is that no ordinary tweeters would be adequate, because both sensitivity and power rating would be far below that of the E130. JBL's answer to that need is what



JBL refers to as the 2901A High Frequency Power Pack.

The term "power pack" is explained by the fact that it is a three-element package comprising a high-frequency driver, a high-pass network, and a treble control intended to be mounted in a location which will provide access as necessary when acoustical adjustment is required.

The tweeter is a high-efficiency, compression driver, with integral horn loading and a frontal high frequency lens to ensure wide dispersion of the sound. With aluminum voice coil and an impregnated phenolic diaphragm, it has a normal impedance of 16 ohms but is suitable for use with either 8-ohm or 4-ohm circuits, and with power rating up to 300-watts continuous program.

So much for the design philosophy behind musical instrument loudspeakers and the particular pair of drivers chosen for the system described here.

### Boxing it

Now, let's get down to the construction of the enclosure. Overall dimensions of the enclosure are 30-inches high, 24-inches wide and 12-1/2-inches deep. The surface material is 3/4-in. void-free plywood or high density particle board. Internal volume neglecting cleats, padding, and speaker displacement, came out at about 3.8-cubic ft.

Incidentally, the extra cleat around the inside lip of the cabinet of the JBL System is optional, its purpose being

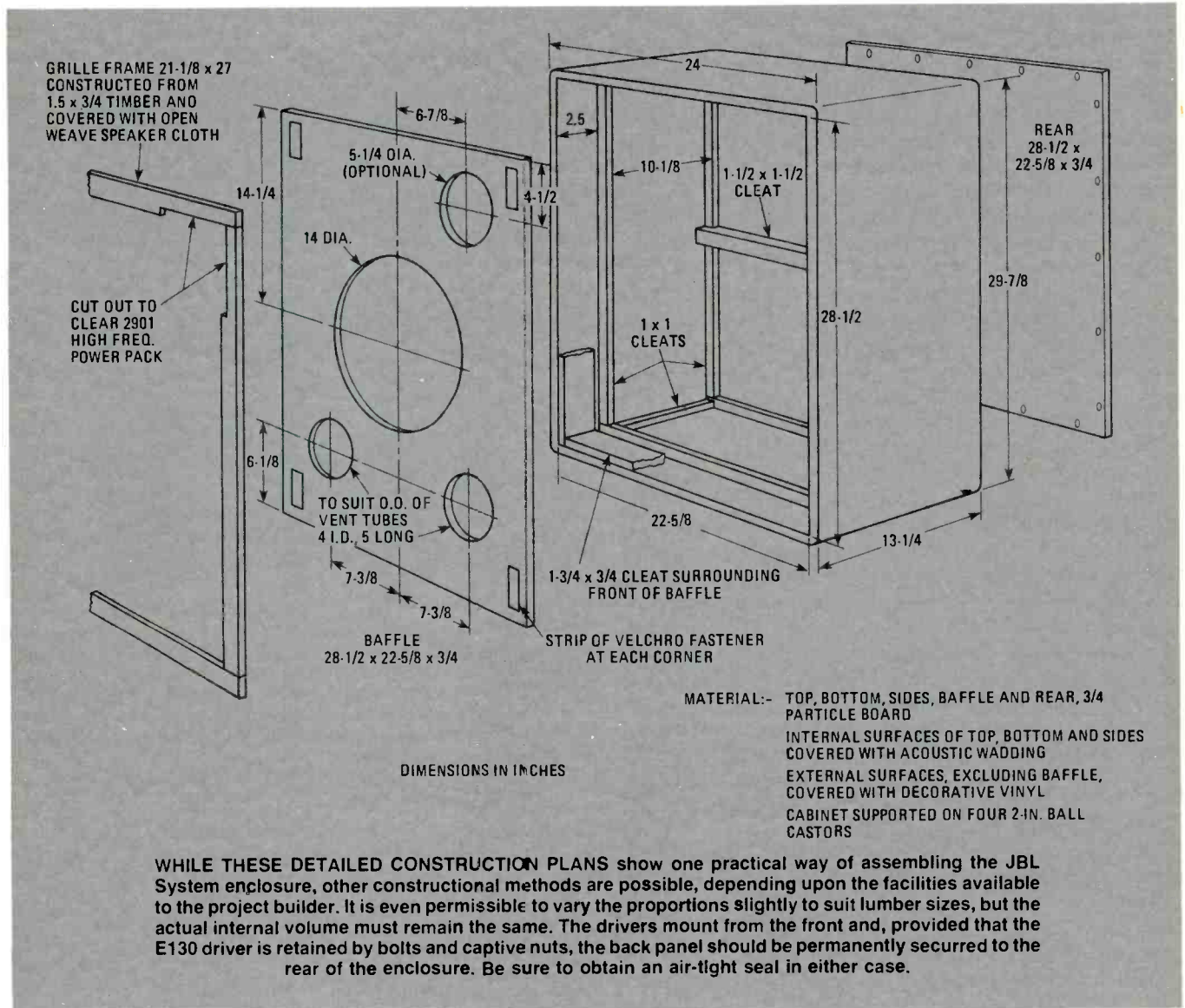

### Treble response

The crossover network is designed to take over above 1.5 kHz and the manufacturer's curve suggests that the 2901A treble driver is flat from 2000 to 15,000 kHz, and about 8 dB down at 20 kHz. While the treble driver can be mounted separately from the base driver, JBL suggests that it should most logically be mounted high up on the baffle of the main enclosure. Since the 2901A driver is sealed off at the rear, it will not suffer any pumping by pressure in the main enclosure from the E130 unit.

partly functional, partly cosmetic. It does lock and seal the baffle firmly in position, and it does increase the thickness of the exposed front edge as a precaution against abuse. It also makes the enclosure look a lot more massive than it really is!

While it would be possible—and even convenient—to cut the holes with the baffle already fixed in position, it may be wiser to prepare the baffle fully beforehand to guard against the possibility of an inadvertent error. Cut the holes as specified, taking particular care with the respective diameters, so that everything will fit neatly and firmly into position. Experience has shown that, with heavy systems constantly being

moved around, things soon loosen up if the fit and the fixing is not to the highest standard.

Whether or not you fit the high-frequency horn will depend on your requirements and your checkbook. Experience would suggest that the K130 alone is quite adequate for lead guitar unless you really want to slice cheese with your strings at 30 feet! The horn really comes into its own with keyboards and Moog.

Both drivers mount from the front, and it is most important that the flanges form an airtight seal against the baffle surface. If there is the slightest doubt about that, it is wise to envisage a gasket, adhesive felt, adhesive foam or non-hardening sealing compound between the surfaces, when the drivers are ultimately bolted into place. Two port tubes will be needed, each 5-inches long and internal diameter nominally 4-inches. Results will not be adversely affected if the tube is  $\frac{1}{16}$ -inch to  $\frac{1}{8}$ -inch oversize. Individual constructors may be able to obtain suitable scraps of large diameter cardboard tubing, or plastic drainage tubing, or even make up their own by gluing and rolling sufficient layers of stout paper or light cardboard.

Alternatively, rectangular port tubes could be fabricated from scraps of plywood or masonite, securely pinned and glued at the corner, and then glued into matching cutouts in the baffle. The length would have to be the same as for the round tubes but the internal cross-sectional area would have to be manipulated to about 12.6 square inches.

After pinning, gluing, and sealing the port tubes into position, the whole front of the baffle and the inside of the tubes should be painted flat black. The baffle should not be ready to build into the cabinet.

While we have assumed the use of cleats, the main enclosure can be assembled in any way that will ensure that it is completely rigid and airtight, except for the deliberate air path through the twin ports. That is important acoustically because with the internal pressures generated by a speaker of such power rating, panel rattles or air whistling through cracks can be very obvious. Furthermore, a relatively bulky enclosure, manhandled frequently into vehicles and onto platforms, will soon loosen up if not put together rigidly.

For that reason, all joints should be glued and screwed at the time of assembly. For homebuilders, we would suggest propping the cabinet at various angles, running a line of PVC glue along each joint in turn, and leaving it to set. Not only will that add strength, but the glue will also form a meniscus seal wherever it is so applied. Where the baffle is a fixture, some may prefer to have the back panel removable. Alternatively, if the bass driver is secured by bolts and captive nuts, access to the inside of the enclosure could be through the base-driver cutout. However, assuming the former, the back panel must fit snugly against its own cleats, with a *generous* number of screws to hold it in position. We would suggest that it be bedded down against a strip of adhesive foam, to take up any slight discrepancy in the mating surfaces.

### Internal Damping

Before the back panel is screwed in place, however, the sides, top, bottom, and the inside of the panel itself should be lined with a layer of acoustically absorbent material, typically about 1-inch thick. Heavy-duty carpet underfelt (not foam), fiberglass, or bounded acetate are all suitable for the purpose, glued and/or stapled firmly into position, so that they will not droop against the inner ends of the port tubes. Do not pad the surface areas on the rear of the baffle.

In fact, some musicians tend to argue against fully padding

the inner surfaces of a music enclosure on the grounds that it tends to "dull" the sound. Others compromise by padding only one of each pair of facing surfaces to permit more build-up of standing waves inside the box to be heard through the cone as extra mid range brightness.

### Surface finish

About now, the surface finish will have to be added. Painting or staining is easy, but dubious in terms of eye appeal and durability. Veneers or laminates don't really belong to the pop-music scene. Thin black carpeting is a "with it" finish but difficult and expensive to organize. Good quality, cloth-backed vinyl is probably the best all round choice, glued over the entire surface.



**FITTED WITH CORNER PROTECTORS, flush side handles and 2-inch castors, the enclosure takes on the "pro" appearance. The enclosure is rigid, rugged, and is no more bulky than it needs to be for the job of making a really big blast from lead guitar or keyboard input. A semi-transparent black grille cloth provides the necessary professional-lock finish, while giving a hint of the hefty JBL drivers behind.**

The final job is to fit and wire the loudspeaker (or speakers). In the case of a single E130, leads need to be run from the terminals to whatever output connection is required on the rear of the enclosure. It is conventional, in music circles, to use a standard  $\frac{1}{4}$ -inch phone socket, connecting the red (plus) speaker terminal so that it will connect to the tip and the black terminal to the shank of the input plug.

Where a high-frequency driver is used as well, that will have to be interconnected, along with its splitter or crossover network. In the prototype unit black wires run to the respective speakers negative terminals, a white wire to the high-frequency driver plus, and a red wire to the E130 plus.

For those planning to build their own enclosures, the lumber, oddments, and finishing materials would have to come from the usual lumber-supply sources. Right now, we do not know of any pre-cut panel kits for the particular JBL system described here. JBL loudspeakers can be obtained from, or ordered through JBL dealers in the United States and Canada. For specifications and data write to Professional Division, JBL Sound, Inc., 8500 Balboa Boulevard, Northridge, California 91329.

**SP**



# Electronic SLOT MACHINE

***Three sevens is a winner, and you will win for sure when you finish wiring this enjoyable game!***

BY LARRY GLENN

SOMETIMES A PROJECT CAN BE A LOT MORE TROUBLE THAN IT'S worth. For example, an Electronic Slot Machine can be a lot of fun at parties or at a School Fair, or at a Las Vegas Nite for your local charitable organization. The problem is that it's usually not easy to come by the required parts from one source; and by the time you're finished paying for several "shipping and handling charges" most of the pleasure is gone.

Well, we've put some of the fun back in building relatively complex projects by making almost all the parts needed for an Electronic Slot Machine available from a single source. If you don't have the parts in stock, or can't locate a few items locally, you can purchase almost the whole kit and kaboodle from Chaney Electronics, Inc.—you'll get everything except one small power jack that we'll cover later.

The Electronic Slot Machine is a modern version of the old "one-armed bandit." You bet your money and press a button. Three seven-segment LED digital-readout devices show whether you've won or lost. The devices can display either the numeral 7, a dash, or the letter "L" for "you lose."

If you hit three sevens or three dashes a tone sounds from

an internal speaker to indicate you have won. Should any other combination of sevens, dashes or L's appear, you lose.

The small internal speaker sounds rapid ticks as long as PB, the push-button operating switch, is depressed. (Note: we used PB instead of S1 so as to conform to the parts supplier's nomenclature.) When the button is released, the tone will sound if you hit a winner. Like the mechanical slots, the Electronic Slot Machine can tease. Two digits can lock while the third one rolls in. The tone might sound for an instant as if you have won, but then it ceases as the third display rolls to a loser. Alternately, you might lose, only to have the third display roll in as a winner. And typical of the mechanical slots, you can more or less program whether a winner will come up frequently, rarely, or almost never. It just takes a bit of playing with the adjustments, and we'll tell you more when we get to the final alignment.

Though the project *can* be powered by a 9-volt battery (see Fig. 1), its total operating life isn't all that much. Normally, two parallel connected alkaline batteries are suggested, but even they don't provide extended life. That's because the project idles at about 100 mA, and consumes almost 250 mA

FIG. 1—SCHEMATIC DIAGRAM for the Electronic Slot Machine gives the reader a clue as to the complexity of the printed-circuit foil pattern.

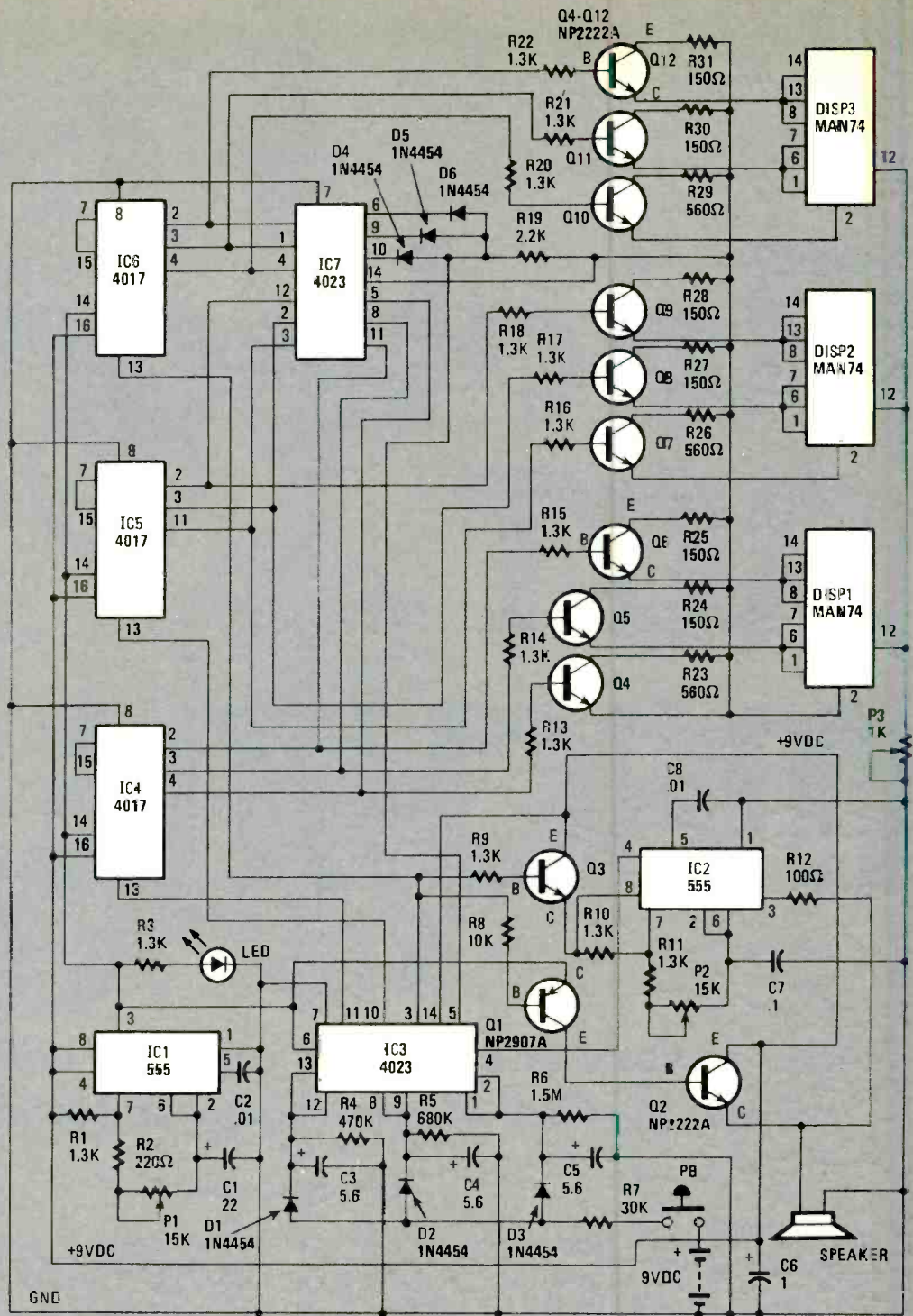

**PARTS LIST FOR ELECTRONIC SLOT MACHINE**

**SEMICONDUCTORS**

- D1-D6—1N4454 silicon switching diode
- DISP1-DISP3—MAN74 light-emitting diode display
- IC1, IC2—555 timer integrated circuit
- IC3, IC7—4023 triple 3-input NAND gate integrated circuit
- LED—Light-emitting diode, jumbo red
- Q1—NP2907A PNP silicon transistor
- Q2-Q12—NP2222A NPN silicon transistor
- IC4-IC6—4017 decade-by-10 counter with 1-of-10 outputs integrated circuit

**RESISTORS**

Resistors can be 1/2- or 1/4-watt, 5% or 10% composition units unless otherwise noted

- R1, R3, R9-R11, R13-R18, R20-R22—1300-ohm
- R2—220-ohm
- R4—470,000-ohm
- R5—680,000-ohm
- R6—1.5-Megohm
- R7—30,000-ohm
- R8—10,000-ohm
- R12—100-ohm
- R19—2200-ohm
- R23, R26, R29—560-ohm
- R24, R25, R27, R28, R30, R31—150-ohm
- P1, P2—15,000-ohm subminiature trimmer potentiometer
- P3—1000-ohm, trimmer potentiometer

**CAPACITORS**

Capacitors are rated at 15-WVDC or higher

- C1—22-μF electrolytic

- C2, C8—.01-μF disc
- C3-C5—5.6-μF electrolytic
- C6—1-μF electrolytic
- C7—.1-μF disc

**ADDITIONAL PARTS AND SUPPLIES**

PB—N.o., miniature, pushbutton switch  
 Miniature speaker, battery connector, 9-volt battery, wire, solder, printed circuit material, hardware, 4 rubber feet, etc.  
 (Note—an optional jack and battery eliminator can be substituted for the battery connector and battery—see text.)

A complete set of parts for the battery-powered version, which also includes a drilled, printed-circuit board, is available from Chaney Electronics, Inc., P.O. Box 27038, Denver, CO 80227. Price is \$29.95 plus \$1.50 for handling and UPS shipping. Price for printed-circuit board only is \$10.00 plus \$1.50. Master Card and VISA orders may be called in to 1-303-781-1589 or 1-303-781-5750.

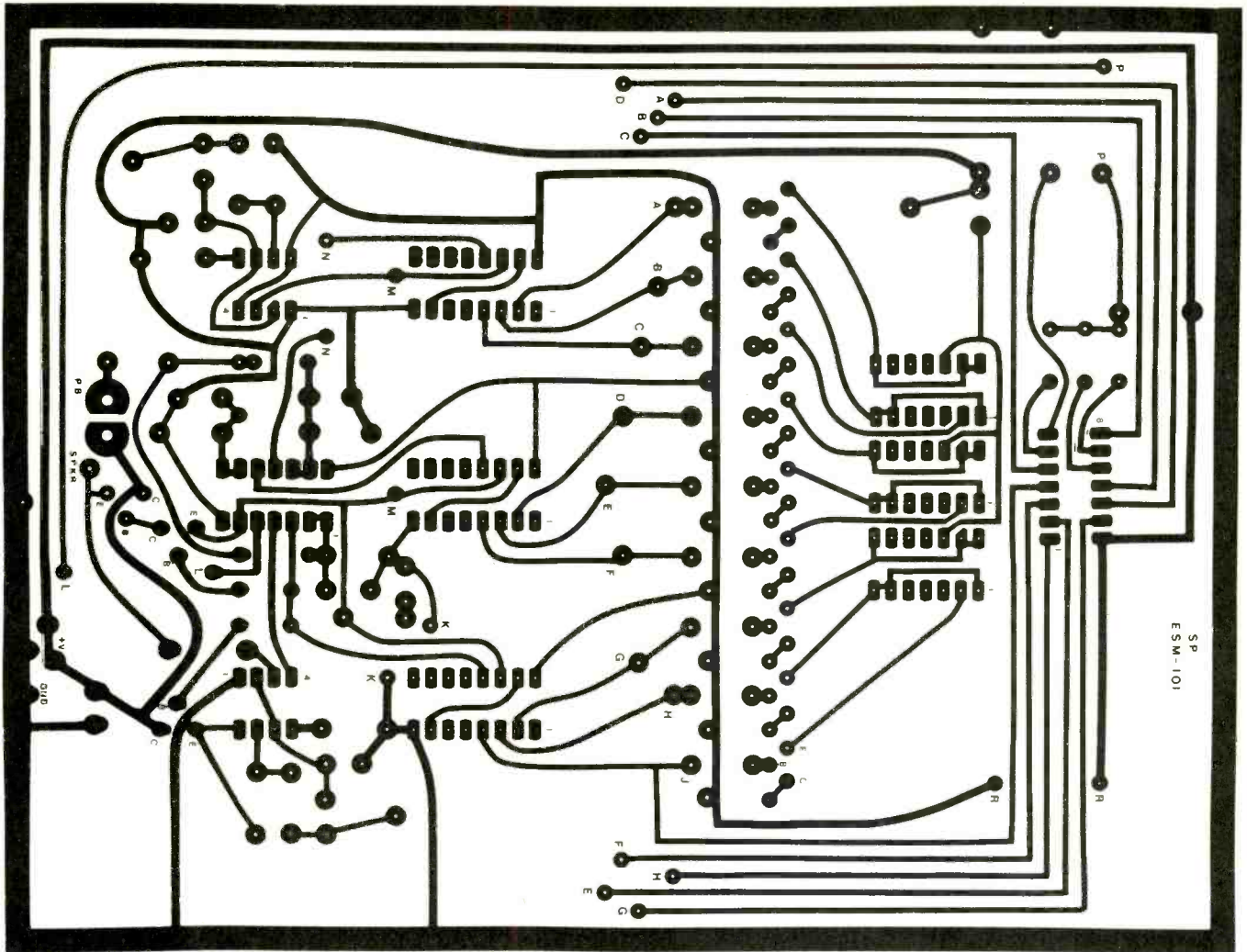

FIG. 2—SAME-SIZE FOIL PATTERN simplifies the planning of a circuit board or wire-wrap hookup.

when running. But alkaline batteries are expensive; the price of a single set will almost pay for a 9-volt battery eliminator (rated about 250+ mA) that will handle the power requirements at no further cost.

### Construction

The Electronic Slot Machine is assembled on a  $5\frac{7}{16} \times 7\frac{1}{16}$ -inch printed-circuit board. Any type of copper-clad board can be used. The foil pattern (see Fig. 2) is more or less well open, so there are no special mounting problems as long as you use a soldering iron with a pencil tip rated at 25 to 60 watts.

Take careful note that potentiometers P1 and P2 are the subminiature type, while P3 is the miniature type. If the potentiometers you use are another size, make certain you modify the printed-circuit board's template. If you purchase the kit from the source given in the Parts List, the supplied potentiometers will match the PC-foil's pattern.

All component holes in the printed-circuit board, except for switch PB, can be made with a #58 or a #56 bit. A string

**SOME SOLID-STATE DEVICES** used for the Electronic Slot Machine are CMOS types, which are very sensitive to static electricity. The problem is essentially eliminated if your body is grounded when handling the CMOS IC's. Connect one end of a wire in series with a 1-megohm resistor, and connect the free end of the resistor to an electrical ground. Connect the free end of the wire to a small alligator clip and secure the clip to your metal watchband or the metal buckle of a leather wrist strap.

of holes enlarged into a slot is required for PB's terminals.

The speaker can be any  $1\frac{1}{2}$  or  $1\frac{3}{8}$ -inch, 8 ohm type. Though there is no indicated position for it on the printed-circuit board, as shown in the photos it can be cemented to the board using silicon-rubber (RTV) adhesive. Before actually cementing the speaker in place, mark the location of the speaker on the printed-circuit board and then drill two holes near the speaker terminals. The speaker's connecting wires will be passed through those holes to the underside of the board and routed to the solder pads that provide the speaker



output. While you're cementing the speaker in place, also cement four rubber bumpers or mounting feet on the underside of the board near each corner.

### CMOS chip installation

Install all the other components before you install the four CMOS integrated circuits; they are installed after all other components and wires are soldered in place (see Fig. 3). The reason for using extra care with the CMOS IC's is that CMOS devices are very sensitive to static electricity until they're connected into the circuit. The static electricity built up in your body from simply walking on a carpet, or wearing a

synthetic fiber sweater, is enough to zap a CMOS device—and you'll never know it until you try to run the project.

The CMOS IC's are easily identified because they are supplied wrapped in aluminum foil, or pressed into a piece of conductive foam—a thin black, porous, plastic material. Don't remove them from the foil or foam until you're ready to install them. To avoid damage caused by static electricity—which is instantaneous; there is no second chance—handle the CMOS IC's only if you are grounded through a ground strap.

All you need to make a ground strap is about six feet of insulated wire (any light size), a 1-Megohm, 1/2-watt resistor

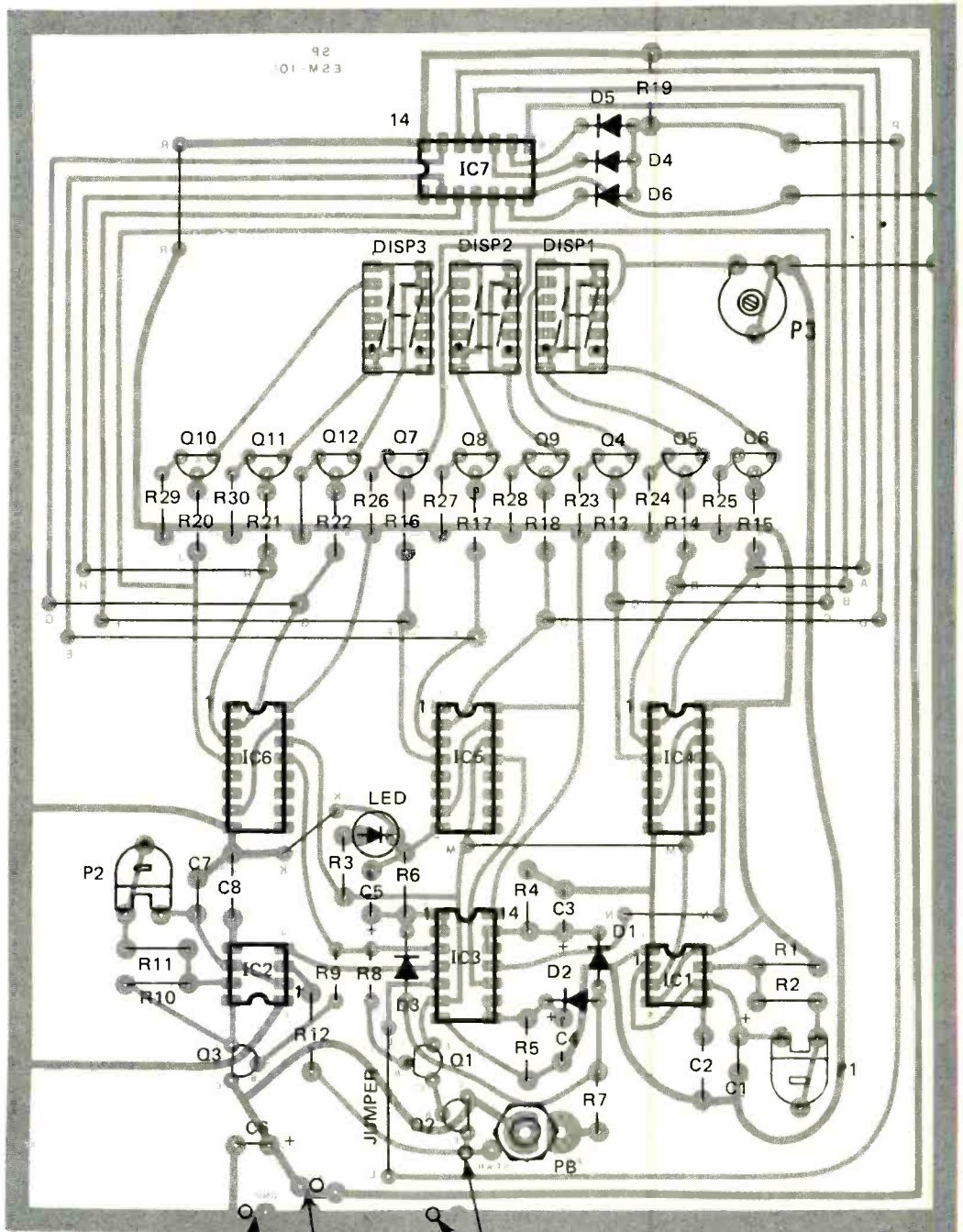

FIG. 3—PARTS LOCATION is shown here in this diagram with a photo of the actual unit for comparison. Your board should look like the photo when the Electronic Slot Machine is completed.

and a small alligator clip. Connect the wire, resistor, and clip in series; then connect the free end of the wire to an electrical ground, such as the small screw that secures the metal cover plate of a 120-volt AC convenience outlet. Make certain that the screw is really at electrical ground; if the cover plate is plastic, there's a good chance that the wiring is ungrounded Romex—so the box won't be at ground. As a general rule of thumb: If you can get a 120-VAC meter reading from one side of the outlet to the screw in the wall plate, the screw is at electrical ground. If the convenience outlet box isn't grounded, connect the free end of the wire to a cold-water pipe.

To ground yourself, secure the clip to any metal part of your watchband that also contacts your skin. If your watch has a leather strap, the buckle is probably metal; so that's where you place the clip. After you're grounded you can unwrap the CMOS IC's and install them.

CMOS IC's also require a grounded soldering iron; it must have a three-wire power cord (one wire is ground). You run a good chance of zapping CMOS devices if you use an ungrounded soldering iron.

#### **Battery eliminator modification**

There's plenty of room on the left bottom edge of the board

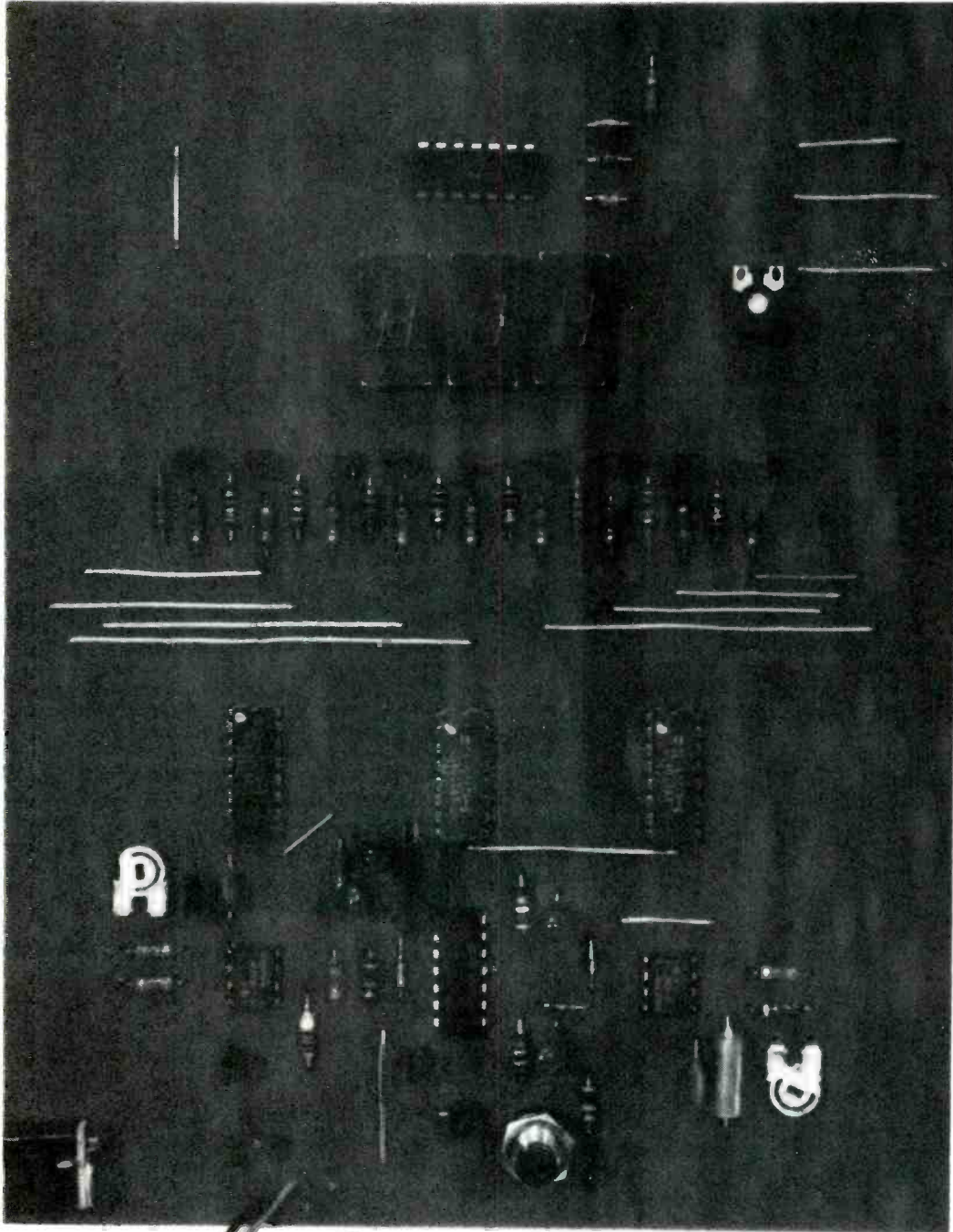



THE SPEAKER CAN BE SECURED to the board by placing a thin bead of RTV silicon rubber adhesive around the rim of the speaker and then placing the speaker face down on the board until the adhesive dries.

for the power jack of a battery eliminator. Select any type of printed-circuit jack that will match the connector on your 9-volt battery eliminator. Mark its position on the board, making certain that you are clear of any foils on the underside of the board. Drill or cut the matching holes; pass the jack's terminals through the holes; and then connect them to the appropriate positive and negative power foils which you'll find are immediately adjacent to the jack. If you use solid #20 or #22 wire for the connections, the jack will be secured to the board without need for a drop or two of adhesive or epoxy.

You apply power to the Electronic Slot Machine by simply plugging in the battery eliminator, or connecting the battery. There's no need for the extra expense of a power switch.

### Checkout and adjustment

Set all three trimmer potentiometers to the mid position, then apply power to the Electronic Slot Machine. That should cause some form of indication on each of the three display devices, and the LED located near switch PB should pulse. There will be no sound from the speaker. If you don't get those conditions, it's more than likely there is a wiring error. Check the orientation of the LED and the IC's, the diode polarities and capacitor polarities, and finally the battery/eliminator polarities. Take particular care to check the installation of the two type-555 timers, IC1 and IC2; the "dot" on one faces the bottom of the board, while the "dot" on the other faces the top of the board.

Potentiometer P3 controls the brightness of the display, and therefore has a substantial effect on the total current drain. If you're using batteries, set P3 for the minimal usable brightness. If you're using a battery eliminator you can set the brightness at maximum.

Potentiometer P2 controls the tone frequency and the pulsation rate of the LED. Potentiometer P1 controls the "spin" rate of the display and speaker's associated clicking sounds as the display "spins." A relatively slow rate produces very few winners. A moderate rate gives a winner on an average of every five to seven tries. A fast rate improves the winning odds, and will hit an average of one out of every two or three tries. The adjustment range of the pot is narrow, so it takes a careful adjustment to set the "winning odds" you would like to have.

Because the power-supply voltage affects the "spin" oscillator, if you use a battery-power source, the winning odds will change as the battery voltage runs down. **SP**

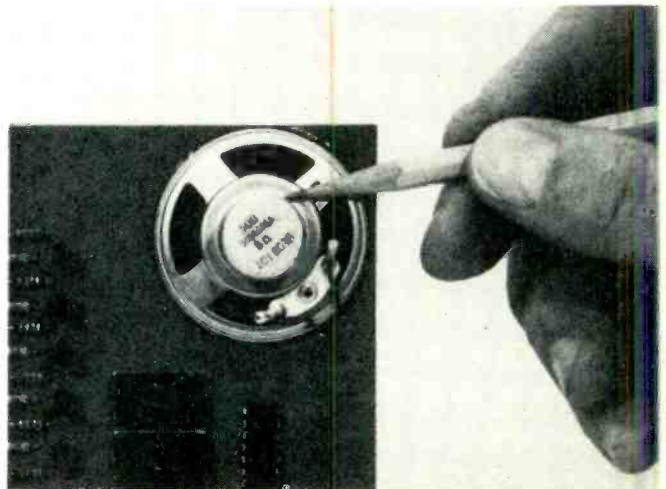

THE PENCIL POINTS TO the speaker, which can be installed "face down" on one corner of the PC board. It is installed right over one of the "jumpers," which should be connected first.

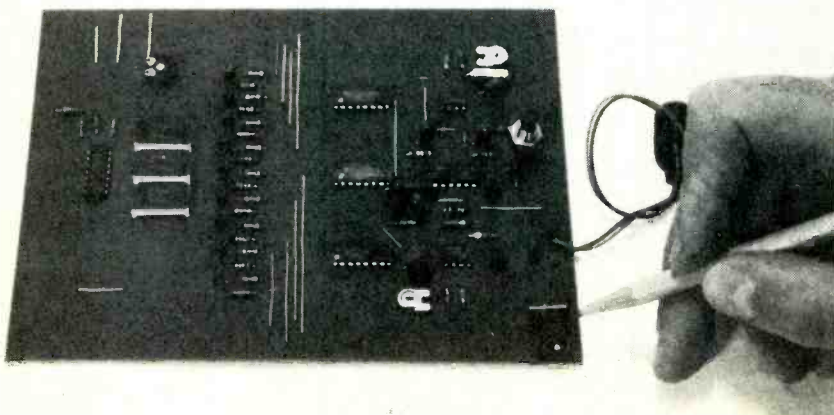

THIS IS HOW the finished unit will look before you figure out what to do with the speaker. Everything except the battery eliminator jack at the lower right (pencil points to jack) is supplied in a kit. You must obtain locally the jack that matches the battery eliminator you plan to use. If you don't use the eliminator, you connect the batteries to the battery snaps coming out of the right side of the circuit board.



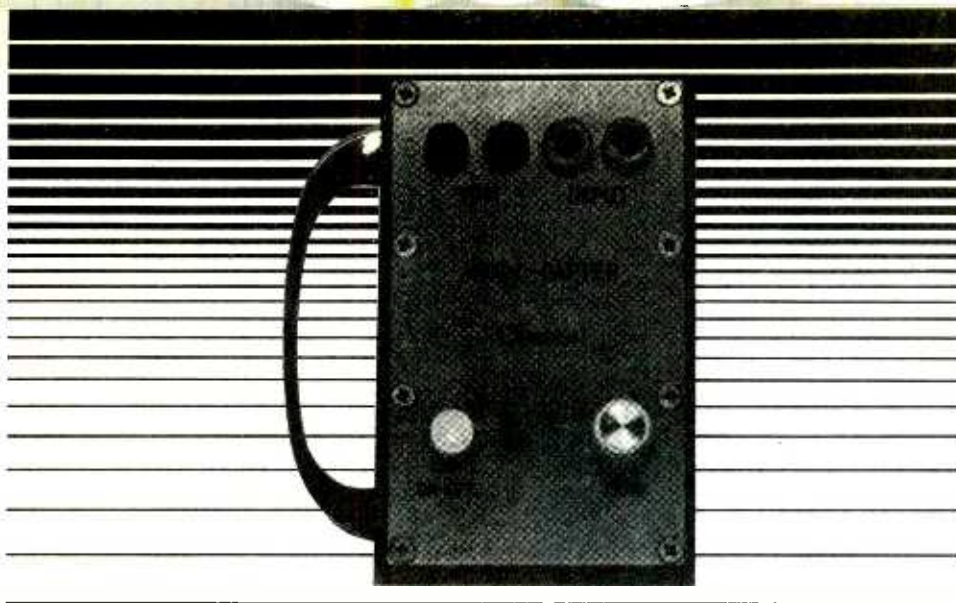

# MEG-O-DAPTER

LAWRENCE M. WALDEN

WITH THE TIGHT ECONOMY, MANY OF US ARE EXTENDING THE life of home appliances, electrical tools, test equipment and salvaged parts. This can be done with considerable savings; but, is it safe?

Many technicians depend on their volt-ohmmeters (VOM) even for insulation testing. For AC line-operated equipment, the potential used in the ohmmeter circuits are not high enough compared to Megohmmeters, or meggers, which have potentials from 500 to 1000-volts DC.

Now, a simple adapter, we call it the Meg-O-Dapter, can be used with most analog multimeters without any modification to the meter circuits. This adapter provides an open-circuit output variable from zero to 1000-volts DC. Although these high potentials sound frightening, current levels are only 50 or 60 microamperes. Any charge on capacitances in the unit tested is dumped, or discharged, through normally closed contacts of the momentary-contact power switch.

## Speaking of Megohms

Insulation resistance of an appliance may vary depending on age, moisture, corrosion, and dirt. Resistance will vary from several Megohms to infinity. Most low readings are caused

by moisture and can be corrected by drying the appliance in a low-temperature oven. Heat will also cause lower readings so a second reading should be made after cool-down. In cases involving grease or carbon from brushes, washing the appliance with a cleaning solvent and re-drying can help. For harsh environments, insulating varnish can seal motor or transformer windings after cleaning and drying.

Three different model multimeters were tried requiring from 660 to 780 volts DC. This was the open-circuit voltage after zeroing. The first multimeter model was calibrated in Megohms multiplied by three; the second, calibrated in Megohms divided by two; and the third, calibrated directly in Megohms. All models were accurate over the entire scale with center-scale readings of 15 Megohms and full-scale reading of 2000 Megohms. The Meg-O-Dapter must be calibrated for each model but requires only one calibrating resistor.

All capacitors, excluding electrolytic types should show an almost infinite leakage resistance within their rated voltage. With the ZERO control on the Meg-O-Dapter adjustable from zero to 1000-volts, DC, any selected voltage may be used. Resistance readings at reduced voltages will be incorrect but this is not important for insulation leakage tests.

***This handy little box permits  
your direct reading of Megohms  
from the face of your DC voltmeter***

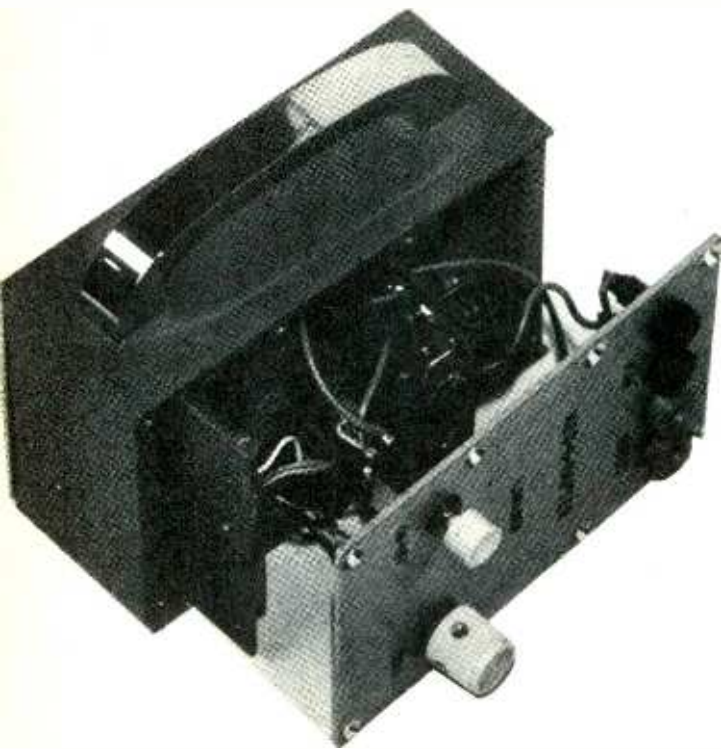

**THE MEG-O-DAPTER IS A COMPACT UNIT. Removing some screws and lifting the front cover reveals the two circuit board—low voltage and high voltage. Box sides have slots to hold printed-circuit boards in place.**

Small capacitors, even below 50 pF, will show a charge "kick" on the meter.

All capacitance, which includes wiring, motor windings, etc. can store high charges when there are no leakage currents. For safety, a momentary contact power switch built into the Meg-O-Dapter is used to discharge, or dump, this capacitance.

The Meg-O-Dapter is powered by a 9-volt transistor battery and will operate between 6.5 and 10 volts with a current drain between 15 to 25 milliamperes. With only two controls, power ON/OFF and ZERO control, operation of the adapter is simple.

1. Plug output leads into the VOM and set to selected DC voltage range.
2. Short input leads depress power switch, and adjust ZERO control for zero reading on meter's ohms scale.
3. Release power switch and connect leads to circuit or component to be tested
4. Press power switch on for direct meter readings.

For lower voltage testing, controls are set as above except for ZERO set in step 2. With leads shorted, adjust ZERO control for pre-determined point on meter which will give the desired open-circuit potential. External capacitance, depending on value, will require time to reach full charge. This can range up to several seconds for large values.

### Circuit description

The schematic diagram for the Meg-O-Dapter (Fig. 1) is shown with the momentary contact pushbutton switch S1 in

the OFF position. This switch, a double-pole, double-throw type, is wired with S1-a in the normally-open position; and S1-b, normally closed. In the off position, S1-b will discharge any capacitance across the input through R14, a 1000-ohm resistor.

When depressed, S1-b opens and S1-a closes to supply power to transistors Q1, Q2, and IC1 and their associated circuits. IC1, a 7555 timer, operates as an astable multivibrator producing a nine-volt squarewave output. This output connects to ZERO adjust potentiometer R4. The variable output from the wiper of R4 feeds through capacitor C3 to the base of Q1. Emitter current from Q1 passes through R6 to the base of Q2 which drives transformer T1. A high voltage develops across the secondary of T1 which feeds a voltage doubler composed of D1, D2, C5, and C6. This high voltage DC, controlled by ZERO control R4, can be varied from zero to over 1000-volts DC.

Three 10-Megohm bleed resistors, R7, R8, and R9 connect across the high voltage connected in series with a test jumper. For open-circuit voltage measurements, the jumper is removed and replaced by a microampere meter. The open-circuit voltage will equal the microamperes  $\times$  30 Megohms.

The positive high voltage also passes through resistors R10, R11, R12, and calibration potentiometer R13 to the INPUT jack J1. Any leakage current, from the circuit under test, returns to the negative INPUT jack J2 and is connected in series with the VOM before returning to the negative side of the high voltage source in Meg-O-Dapter.

For meter protection, and the reduction of resistors required in the calibration circuit, the VOM is set to a DC voltage range. Depending on the VOM selected, a range of 50 to 100 volts or more can be used. Once calibrated to a particular VOM, recalibration would be necessary for use with any other make or model.

### Construction and calibration

All parts and components are standard off-the-shelf items. Layout is not critical and can be made point to point on

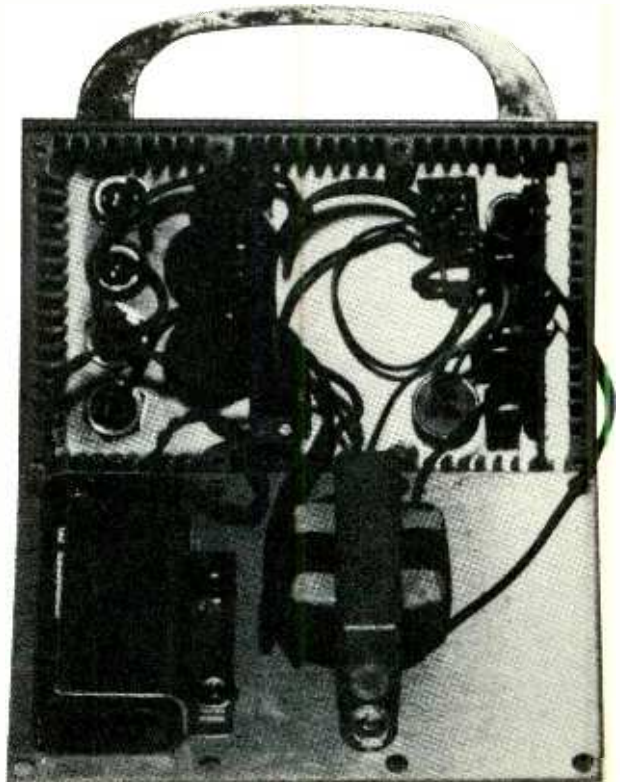

**REMOVE THE BACK COVER and you'll discover that the transformer and battery are mounted on it. Be very careful when laying out the parts location before you drill holes—check clearances.**

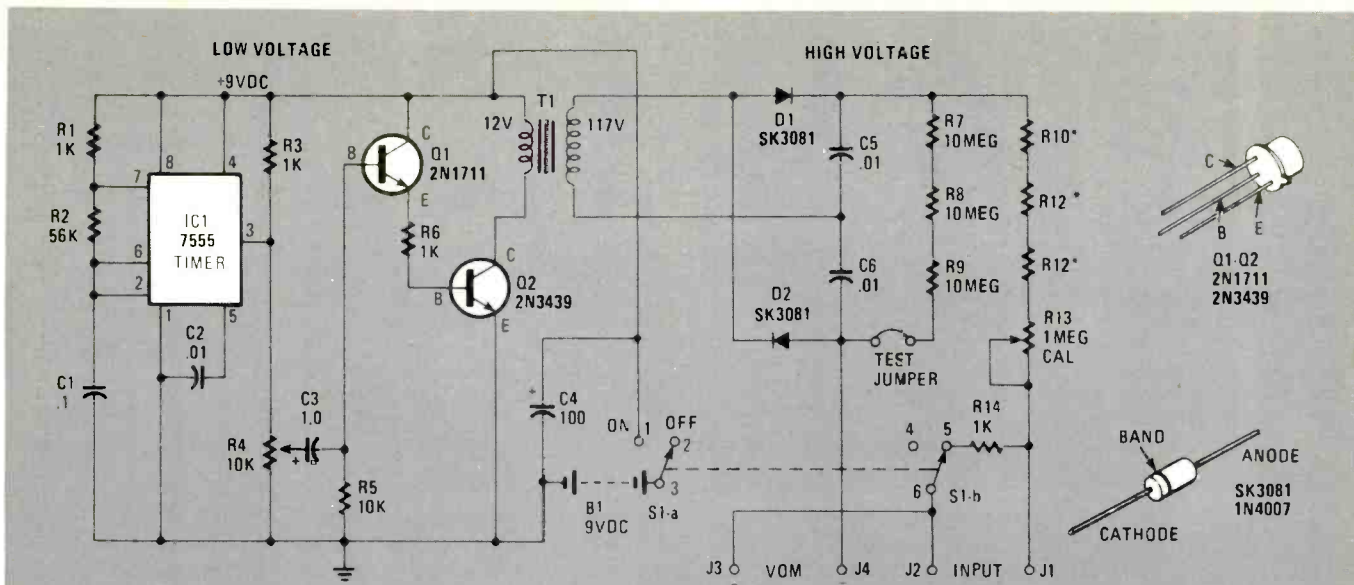

**FIG. 1—COMPLETE SCHEMATIC DIAGRAM** for the Meg-O-Dapter clearly illustrates the isolation between the *low-voltage* circuit and the *high-voltage* circuit. The 7555 CMOS integrated circuit is identical in function to the common 555 chip but draws very little current, greatly extending the useful life of the transistor battery (B1) power supply. The Stancor transformer specified for T1 in the Parts List should not be replaced or substituted. Switch S1 is a spring-return type shown in the schematic diagram in the at-rest position. Check out transistor and diode connections.

perf board. A model 3301 Pomona case was used measuring 4¼-inch long by 2½-inch wide by 1½-inch deep. Two circuit boards were used measuring 1½-inch × 2¾-inch with all low-voltage components on one board and all high-voltage components mounted on a second board. Transformer T1 and battery B1 are both mounted on the bottom cover.

Pin jacks are used for the VOM output, J3 and J4, and banana jacks J1 and J2 used for the inputs and were mounted near the top of the top cover. Power ON/OFF switch S1 and ZERO control R4 were mounted on the top cover between the low-voltage board and T1. Due to the close tolerance of the above components, care should be used in their location.

The low-voltage PC board (Fig. 2) can be completed and the voltage doubler with the bleed resistors installed on the high-voltage PC board (Fig. 3). Connect a micro amp meter in place of the test jumper. See Fig. 4. Press power on and

turn ZERO control, R4 to maximum. Output current should range from 30 to 35-microamperes which would equal 900- to 1050-volts DC open circuit.

For calibration, a 30- to 50-Megohm resistive source should be used. The exact value is not important for meter scale selection but accuracy will depend on the values selected. For example, 3 or 4 ten Megohm resistors may be series connected but they should be 1% rated.

The VOM to be used can now be connected to the circuit in the 50- to 100-volt DC range. Values for resistors R10, R11, R12, must be selected. These values will vary depending on the meter used. Begin with R10 at 4.7 Megohms, R11 at 2.2 Megohms and R12 at 1. Connect precision resistors to the input and adjust ZERO control R4 for the exact reading on the meter scale. On some models this reading can read directly in Megohms. On one model VOM, the readings were in

### PARTS LIST FOR MEG-O-DAPTER

#### SEMICONDUCTORS

- D1, D2—1000-PIV silicon diode rectifier, axial leads; SK3081/125, 1N4007, or equivalent
- IC1—7555 CMOS timer
- Q1—2N1711 NPN silicon transistor
- Q2—2N3439 NPN silicon transistor

#### RESISTORS

All fixed resistors are ¼-watt 10%, composition types unless otherwise noted

- R1, R3, R6—1000-ohms
- R2—56,000-ohms
- R4—10,000-ohms, ½-watt carbon potentiometer
- R5—10,000-ohms
- R7, R8, R9—10-Megohms, 5%
- R10, R11, R12—Selected values, see text
- R13—1-Megohm, multiple-turn trimmer potentiometer, PC mount

- R14—1000-ohms, 1-watt

#### CAPACITORS

- C1—.1-µF, 10% Mylar
- C2—.01-µF, 10% Mylar WVDC
- C3—1-µF, 50-WVDC electrolytic
- C4—100-µF, 25-WVDC, electrolytic
- C5, C6—.01-µF, 1000-WVDC disc ceramic

#### ADDITIONAL PARTS AND MATERIALS

- B1—9-volt transistor battery
- J1, J2—Banana-plug jack, one black, one red
- J3, J4—Pin-plug jack, one red, one black
- S1—DPDT, spring-return, pushbutton or toggle switch
- T1—Stancor P8390 117/12-VAC, 150-mA secondary winding, power transformer
- Pomona 3301 aluminum case, knob, PC board materials, battery clamp, 8-pin DIP socket, hardware, wire, solder, etc.

FIG. 2—LOW-VOLTAGE circuit board shown here holds most of the components for this circuit. Board size is critical should you use the Pomona case specified. Should you use a different size case, you may want to resort to a perfboard or wire-wrap techniques—it's up to you.

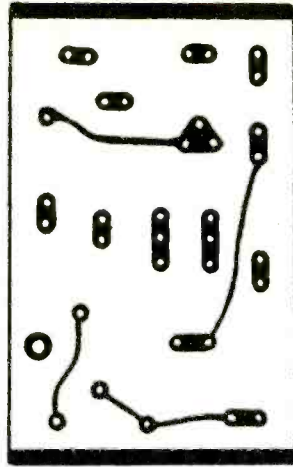
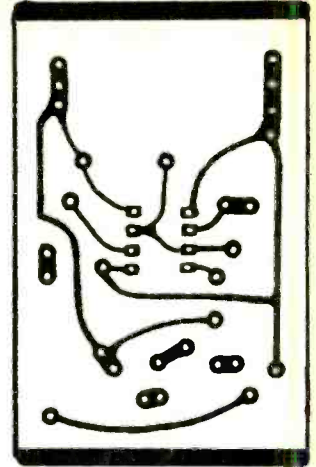

FIG. 3—HIGH-VOLTAGE circuit board is a bit tricky to wire because there's not much room inside the Pomona case. Some parts are mounted on the foil side, and others on the reverse side. Resistor are axially mounted where space demands.



Megohms times 3. One model produced readings in Megohms divided by 2. After adjusting the ZERO control to read the precision resistor value, short the input leads and adjust R13 for a zero meter reading on the ohms scale. If meter fails to reach zero, reduce the value of R11 and R12. Should the meter go beyond zero, increase the values of R11 and R12. These values are not critical as long as R13 is in adjustment range. It will be necessary to repeat this several times. Accuracy will depend on the calibration resistors and the meter itself.

With the VOM calibrated, open-circuit voltages can be selected. Connect the microammeter to the test jumper and set ZERO control R4 for the desired current. For example, 3.3 microamps through the 30-Megohm bleed resistors would equal 100 volts with the input open. Now short the input leads and record meter readings in Megohms. This can be done for any value selected up to and including the zero set point. As mentioned above, resistance readings will be incorrect but are not important for insulation tests.

FIG. 4—PARTS-LOCATION DETAILS for both circuit boards. Note that the boards are electrically isolated except for common transformer T1 and switch S1. All parts are mounted on the foil side of the low-voltage PC board, whereas both sides of the board are used to mount parts on the high-voltage PC board. In the diagram both boards are shown foil up. Hole A was drilled by the author to pass battery B1 leads. In your configuration in the Pomona box, one or more others leads may pass through hole A so drill a slightly larger hole to cover any contingencies. Refer to Fig. 1 when connecting the external leads to switch S1. Photo of high-voltage board is a bit different from drawing below because of last minute changes. Use the diagram.

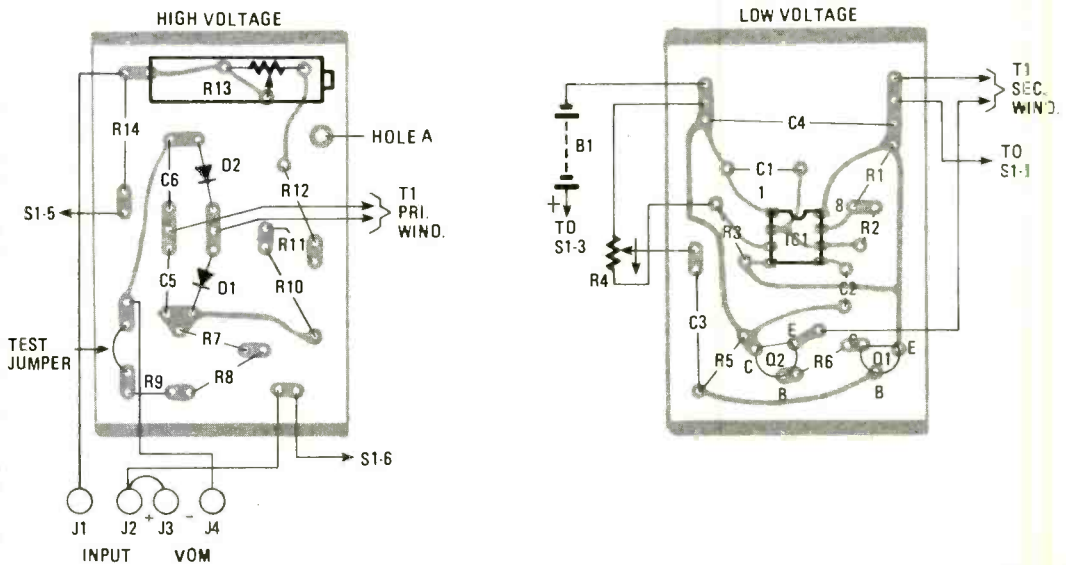
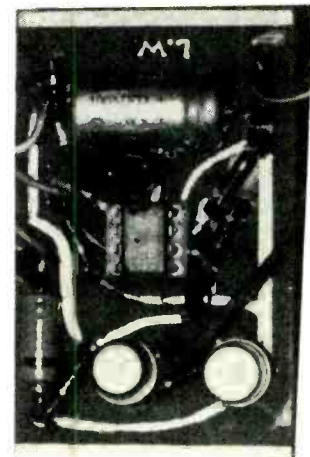
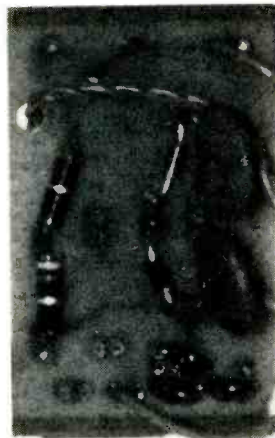

As with most ohmmeter circuits, the set points and zero adjust will depend on the battery voltage. For this reason, ZERO control R4 was not calibrated. With an average battery drain of 20 milliamperes and useful operation down to 6½ volt, the life of B1 should be about normal shelf life.

As mentioned above, lower ranges could be calibrated and include a range switch, but for practical purposes, this does not seem necessary. What is important is that hazardous and deadly current leaks in appliances, electrical equipment and test instruments be detected by Meg-O-Dapter and not a human. SP

# Three-Band Shortwave Converter

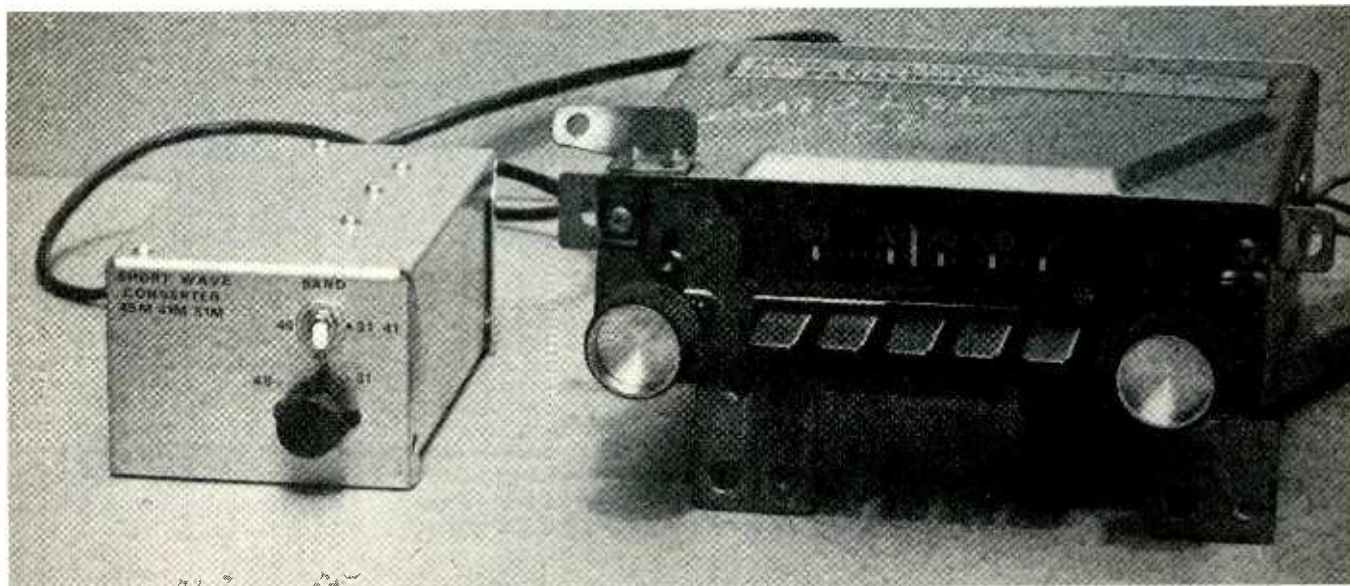

Photos by Melvin Linse

## JACK SPILLANE

HERE IS A SHORTWAVE CONVERTER AND AUTOMOBILE broadcast-band receiver combination that provides reception in the 49-meter (5950 to 6200 kHz), 41-meter (7100 to 7300 kHz) and 31-meter (9200 to 9700 kHz) shortwave broadcast bands; and also WWV, the Bureau Of Standards time signals at 10,000 kHz. Put it all together, it spells highway SWL-DX'ing.

Before we get to deep into this article, let's talk about "highway SWL-DX'ing." Yes, you can use the Three-band Shortwave Converter to listen to distant shortwave stations as you wing down the road, but the term used implies listening at home, too! You see, what we are advocating here is the acapition of an auto car-radio of AM vintage coupled with a home-brew converter to pull in DX from the shortwave bands. Those two units can be installed in your car or they may be set up on your desk with an external power supply to replace the car's battery. The supply need only be a 1-ampere, regulated 12-volt supply of the variety used in many of the projects found in power supplies common to other projects you have read in **Special Projects**.

### The circuit

The input SW-signal is fed from the antenna through ANT jack J1 to a high-pass filter consisting of C1, L1, C2, L2, and C3. (See Fig. 1). That filter is used to reduce broadcast-band feed-through. RF transformer T1 is the combination of an untuned input primary winding and the tuned secondary winding. The latter is parallel with the series capacitors C5 and C6, and tunes from 5950 kHz to 10,000 kHz. The signal is coupled to gate 1 (G1) of Q1, a dual-gate MOSFET transistor used as an RF mixer. Q1 mixes the incoming signal

from the antenna with the output of the crystal oscillator Q2. Small-signal, N-channel FET Q2 operates as a Pierce oscillator. Switch S1 switches in either crystal X1 (5000 kHz) to crystal X2 (8500 kHz) for band switching purposes. The output of Q2 is coupled through C7 to gate 2 (G2) of Q1. The mixed output of Q2 is coupled from the drain (D) of Q1 and its load resistor R6 through C10 to a 16-inch length of RG58A/U coax cable. That cable is terminated by a Motorola-type bayonet connector, P1, to match the antenna-input jack on the automobile receiver.

### The circuit board

The circuit board is a standard prepunched perfboard with .042-inch holes spaced .100-inch apart. Push-in terminals with .042-inch diameters were used to mount the circuit components. The main circuit board is 5.10 inches by 1.30 inch and the filter board is 1.50 inch by 1.10 inch. The wiring of the boards is done with No. 30 insulated wire-wrap wire and soldered to the terminals on the bottom of the board. The rest of the wiring is done with No. 22 insulated hook-up wire. Be sure to use short, direct wiring on the circuit boards and on the crystal switch S1. The main circuit board is mounted in the box with two 1/2-inch, 4-40 screws with two nuts serving as standoffs. The high-pass filter board is mounted in the same way using one screw and a ground lug in the center of the board.

### Coil winding

Transformer T1 is close-wound with No. 22 magnet wire on a coil form made from a 1 1/2-inch long piece of 1/2-inch inside diameter PVC hot/cold water pipe. The pipe actually

***Pull in the hottest three shortwave bands  
with this all-FET tunable converter  
designed to work with an auto radio***

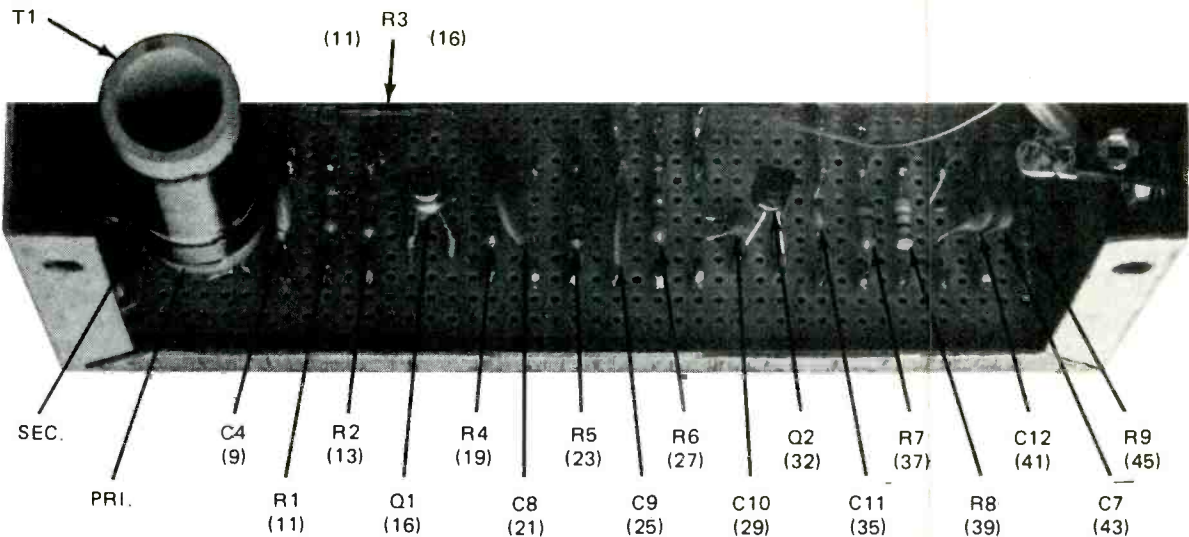

The circuit board is cut to fit the inside of the chassis box used by the author. See Parts List. The board has 48 rows of 11 holes. The numbers in parentheses indicate which row from the left a component part is mounted. Resistor R3, which is mounted horizontally on the board, has two numbers for the two different rows to which its leads are secured. The rows given for the field-effect transistors (FET) indicate the center position on the board about which the leads are terminated. A printed-circuit board for this project is unnecessary.

has an outside diameter of  $\frac{3}{8}$ -inch. T1 is cemented to the circuit board with five-minute epoxy glue. The high-pass filter coils are self supporting and are close-wound using No. 22 magnet wire. A quarter-inch drill-bit shank is used as a winding form. A drop of airplane glue will keep the coils of L1 and L2 in place.

### Testing

Check your wiring carefully before powering-up the unit. Check the operation of the crystal oscillator by monitoring

the current in the positive 12-volt lead to the converter. The current reading should dip from about 14 mA to about 8 mA when a crystal is plugged into its socket. Be sure S1 is set correctly. The dip indicates that the oscillator is working. You could monitor each crystal frequency with a calibrated receiver to check the oscillator operation and frequency accuracy.

### Tuning the bands

All you have to do now is to switch to the proper crystal

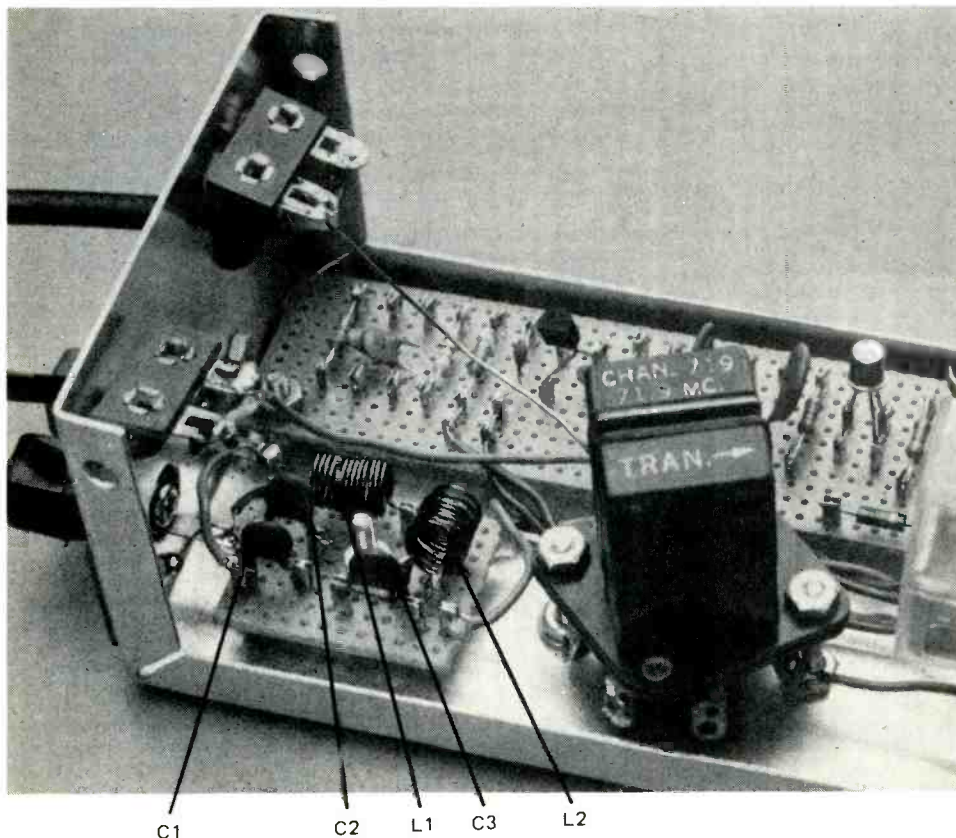

THE HIGH-PASS FILTER-BOARD ASSEMBLY mounts those components used to eliminate as much of the broadcast-band signals as possible without attenuating the shortwave frequencies designed to pass through the converter to the AM auto receiver. One single screw mounts the board on the chassis. Be sure to place lockwashers on the screw between the board and the chassis to prevent the board from rotating. Use two nuts as spacers to eliminate the possibility of a short circuit between the flea-clip terminal tie points and the metallic chassis.

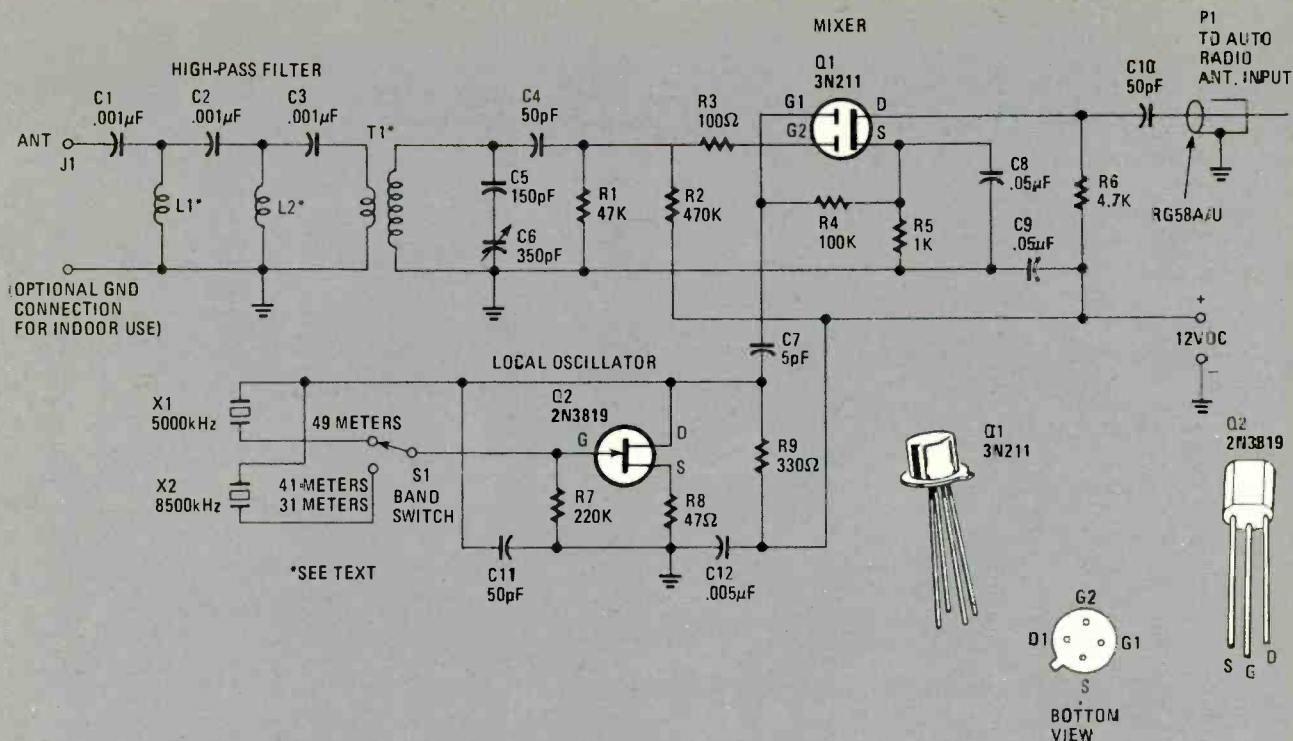

**FIG. 1—THE THREE-BAND SHORTWAVE CONVERTER** schematic diagram looks like this and is simple enough to build. The high-pass filter section is constructed on a separate circuit board, primarily to simplify construction. The remaining portion of the circuit mounts almost entirely on a circuit board in a neat layout, as shown in the photos. No on/off power switch is supplied because the power should be controlled at the power source.

## PARTS LIST FOR THREE-BAND SHORTWAVE CONVERTER

### SEMICONDUCTORS

- Q1—3N211 N-channel, silicon, dual-gate, MOS, field-effect transistor (Radio Shack 276-2045, or equivalent)  
 Q2—2N3819 N-channel, silicon, junction, field-effect transistor (Radio Shack 276-2035, or equivalent)

### RESISTORS

All resistors are 1/4-watt, 5% units

- R1-R7—47,000-ohm  
 R2—470,000-ohm  
 R3—100-ohm  
 R4—100,000-ohm  
 R5—1000-ohm  
 R6—4700-ohm  
 R7—220,000-ohm  
 R8—47-ohm  
 R9—330-ohm

### CAPACITORS

All capacitors are ceramic, 50-WVDC units unless otherwise noted

- C1-C3—.001- $\mu$ F  
 C4—50-pF  
 C5—150-pF  
 C6—350-pF variable (Poly Paks 7060, or equivalent)  
 C7—5-pF  
 C8-C9—.05- $\mu$ F  
 C10-C11—50-pF  
 C12—.005- $\mu$ F

### COILS

- L1, L2,—13 and 10 turns, respectively, of #22 magnet

wire wrapped tight-wound on a 1/4-in. inside-diameter air core—use a 1/4-in. drill-bit shank and slide coil off after winding. Keep leads short.

T1—Use coil form with outside PVC water pipe as air-core form—it has an 5/8-in. outside diameter. Wind 9 turns tight-wound of #22 magnet wire for primary winding. Wind 27 turns tight-wound of #22 magnet wire for secondary winding. Leave approximately 3-turn space between both windings. Drill holes in form and pass all winding ends through core with length of about three inches. Trim unnecessary wire lengths on transformer installation.

### ADDITIONAL PARTS AND MATERIALS

- J1—Antenna terminal—Use any convenient type. Author used push-in loudspeaker terminals; red for ANT and black for GND. Ground terminal not necessary for auto installation.  
 P1—Motorola-type auto-radio antenna plug. Connect to 16-in. length of RG-58A/U coaxial cable  
 S1—SPDT miniature toggle switch  
 X1, X2—5000 and 8500-kHz radio crystal, FT-243 fundamental type\*

Perboard cut to size, push-in terminals for perboard (Radio Shack 276-1394 and 270-1392), chassis box approximately 5 1/4 x 3 x 2 1/2-in., crystal socket\*, 1-3/8-in. length of 1/2-in. I.D. PVC hot/cold water pipe, epoxy, knob, hardware, crystal socket, ground lugs, hardware, wire, solder, etc.

\*Crystals and crystal sockets available from CW Crystals, 570 North Buffalo street, Marshfield, MO 65706. Write for prices and availability—enclose stamped, addressed envelope.

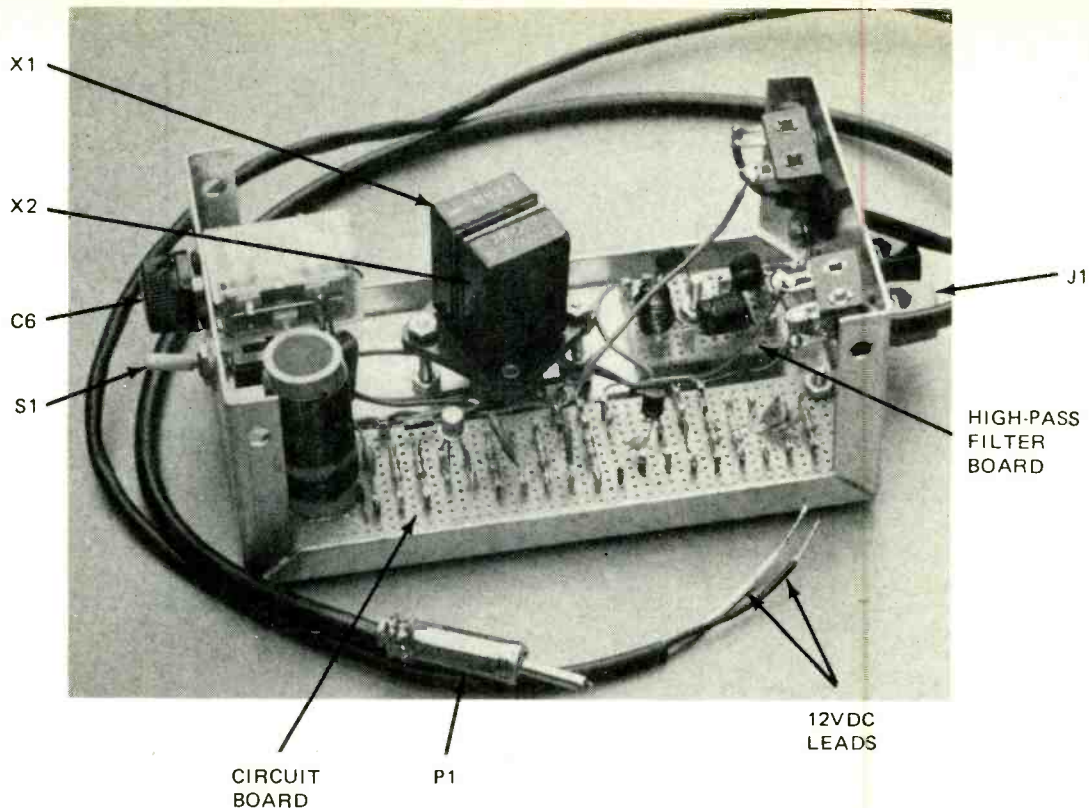

**COMPLETE INSIDE VIEW** of the Three-Band Shortwave Converter. Author's construction is to be admired because the construction is very neat construction. The author used an 8-pin octal tube socket to mount the two crystals (X1 and X2). You could do the same or use sockets specially designed to hold the FT-243-type crystal holders. Its up to you!

frequency and tune variable capacitor C6 to the proper band to receive the shortwave broadcast signals and convert them to a broadcast-band frequency.

All station tuning is done with the dial of the auto receiver. On the 49-meter band the 5000 kHz oscillator mixes with the 5950-kHz to 6200-kHz input signals to produce a tuning range on the auto receiver of 950 kHz to 1200 kHz. On 41 meters (7100 kHz to 7300 kHz) the tuning range is 1400 kHz to 1200 kHz. Notice that the tuning is "upside down" on that band. That is because the crystal oscillator frequency of 8500 kHz is above the incoming signal and you are tuning in the difference signal. On the 31-meter band the 8500-kHz oscil-

lator signal is mixed with the incoming signals of 9200-kHz to 9700-kHz, and the auto receiver tunes from 700-kHz to 1200-kHz. The 10,000-kHz signal of WWV is on 1500 kHz.

For indoor use, an antenna of 25-foot wire strung about a room along the ceiling is good enough. If too long an antenna is used without an external tuner, you may begin to receive unwanted local broadcast signals, depending on your location. For automobile use, tie into the car's AM-radio's antenna. An unloaded full-length CB antenna will serve very well.

A 12-volt power supply with a one-ampere capability works fine to supply voltage to the auto receiver and the converter for indoor use.

Here's a tip: The crystal socket used was an octal tube socket out of the junkbox. Otherwise, you'll have to buy crystal sockets.

Capacitor C6 is one-section of a 3-gang 350 pF per-section variable capacitor sold by Poly Paks for about \$1.00. The series circuit of C5 and C6 makes a maximum value of 105 pF. That system was used to save money and space. Any 100 pF variable capacitor may be substituted. **SP**

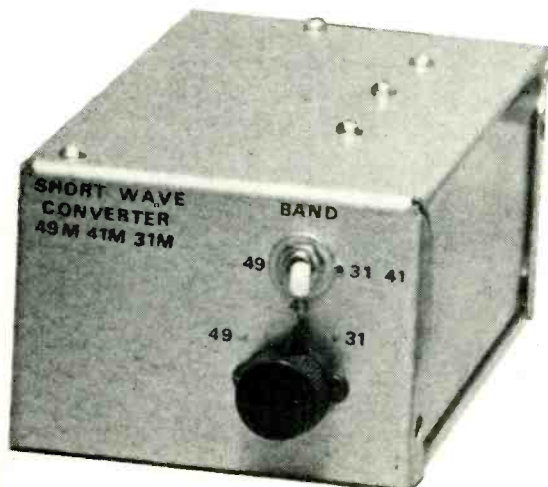

**THE COMPLETELY ASSEMBLED** Shortwave Converter illustrated here fits neatly inside a  $5\frac{1}{4} \times 3 \times 2\frac{1}{8}$ -inch aluminum box. On the 49-meter and 31-meter bands the local oscillator frequency is subtracted from the higher shortwave frequency producing an AM-band signal that increases with station frequency. On the 41-meter band, the oscillator frequency is higher than the shortwave signal producing a mixed signal on the AM-band that is flipped—as the shortwave station frequency increases, the AM tuning dial setting is decreased. Unusual? No, not when the design is made to eliminate extra crystals and special switches.



# scope calibrator



**Here are three squarewave reference voltages that can also serve as the calibration test signal for your oscilloscope's low-capacity input probe!**

H. DAVID HERMAN

A LABORATORY OSCILLOSCOPE WITH ALL THE BELLS AND WHISTLES is probably high on the *wish list* of every electronics hobbyist and experimenter. Unfortunately, they don't come cheap, and many of us must make do with a general-purpose scope from the old days.

But even if your scope is the original Heathkit 0-1, with a variable vertical sensitivity, there's no reason you can't enjoy the modern advantages of a calibrated input sensitivity and a properly adjusted low-capacity probe. All you need is a *pro*-type oscilloscope calibrator, such as you might find in the latest lab scopes...and you can build just such a device—mostly with parts from your junkbox.

Virtually every modern scope with a calibrated input also includes a calibrator, a square-wave signal output of known,

precise-voltage amplitude. To check the calibration of the scope's input, the user touches the test probe to the calibrator test point or output jack. If the CRT doesn't display the correct reading, the user simply *tweaks* the vertical-gain adjustment until the CRT display is correct.

For example, assume that the oscilloscope calibrator's output is a 400-mV peak-to-peak square-wave signal. If the vertical input is set to 100-mV per vertical division, the display height should be precisely four divisions ( $100\text{-mV} \times 4 = 400\text{-mV}$  peak-to-peak). If the CRT display isn't precisely four divisions, the user can adjust the variable-gain control on the scope (if there is one), or the vertical-calibration adjustment until the display height is correct. From then on, the CRT vertical graticule is precisely calibrated. If the user switches to the  $\times 10$  range, each division would represent four volts, and so on for each setting of the vertical-input sensitivity-selector range.

If your oscilloscope is a *basic* model, with only a continuously variable-gain adjustment, oscilloscope calibration can be somewhat difficult if the calibrator has only one output voltage. That problem is avoided by the Scope Calibrator shown in the photographs because it has three outputs: 0.05, 0.5, and 5.0-volts peak-to-peak. Also, instead of a 60- or 120-Hz test frequency, the calibration frequency is the *professional* value of approximately 1000 Hz, which permits precise adjustment of low-capacity test probes.

To explain. Low-capacity probes must be adjusted to match the specific scope with which they're used. Generally,

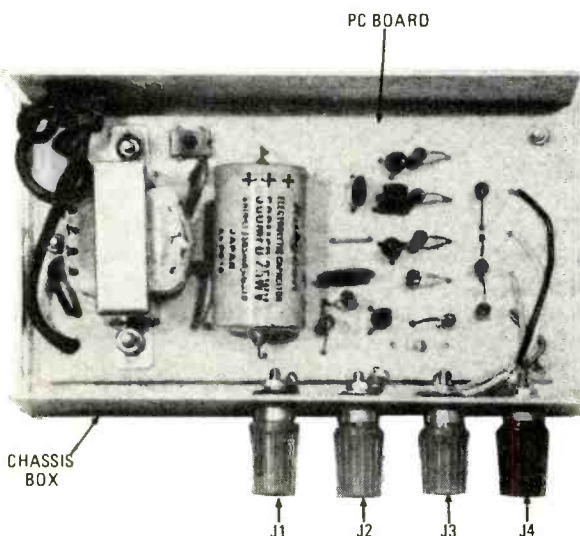

**THE ASSEMBLED PRINTED-CIRCUIT BOARD** just fits inside the specified aluminum chassis box. The connecting wires between the printed-circuit board and the output terminals, J1-J4, are soldered to the foils before the board is installed in the cabinet, and later they are trimmed.

## PARTS LIST FOR SCOPE CALIBRATOR

### SEMICONDUCTORS

BR1—Integrated silicon bridge rectifier, 25 PIV or higher; same as Radio Shack 276-1161

D1—5.1-V Zener diode; see text

Q1, Q2, Q3—2N3391 NPN transistor

### RESISTORS

All resistors are 1/2-watt, 5%

R1, R3, R7—100,000-ohm

R2, R4—33,000-ohm

R5—1000-ohm

R6—1500 ohm

R8—910-ohm

R10—10-ohm

### CAPACITORS

C1, C2—.01- $\mu$ F ceramic

C3—.1- $\mu$ F ceramic

C4—500- $\mu$ F, 25-WVDC electrolytic

### ADDITIONAL PARTS AND MATERIALS

J1, J2, J3—Insulated multi-way binding post, red J4—Insulated multi-way binding post, black (discard fiber washers and mount directly to metal chassis)

P1—AC-power 3-prong plug with power cable attached Aluminum 3  $\times$  2 1/8  $\times$  5 1/4-in. chassis box (LMB type), printed-circuit board materials, hardware, 1/4-in. spacers, wire, etc.

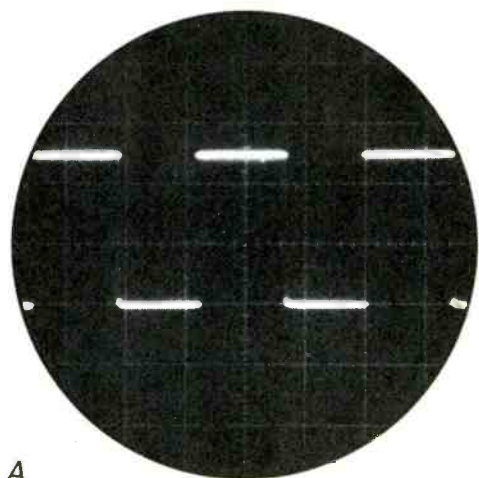

A

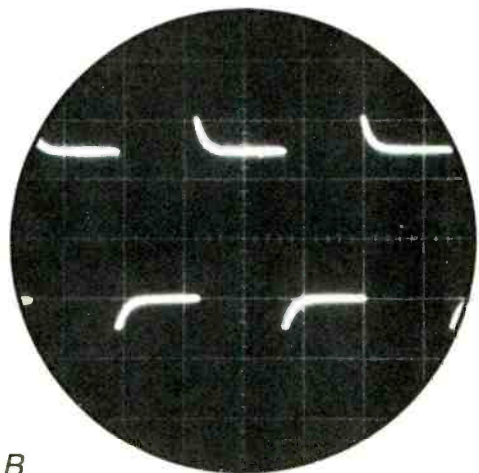

B

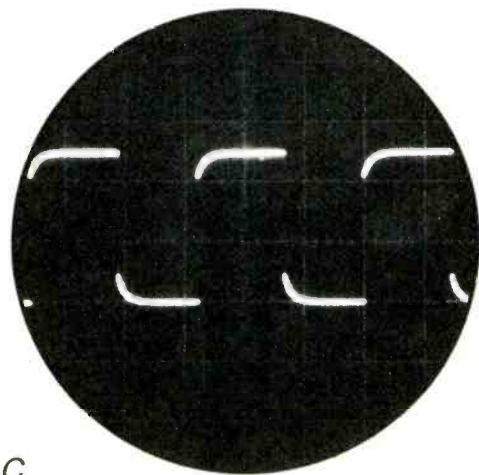

C

FIG. 1—THE TOP AND BOTTOM EDGES of the Scope Calibrator's output (A) are flat, and this is how it should appear on the oscilloscope's CRT when fed through a properly adjusted low-capacity probe. If the oscilloscope probe's capacity is set too low, the leading edge of the waveform will overshoot (B), producing a picket-fence type of CRT display. If the oscilloscope probe's capacity is set too high (C), the high frequencies will be attenuated, producing a rounding of the trace's leading edge.

that is done in the lower-cost probes by adjusting a small trimmer capacitor for a perfectly "square" CRT display. In the more expensive probes, such as those from Tektronix, the barrel of the probe itself is the capacitor adjustment, and is rotated for optimum squarewave form. A properly adjusted probe will produce the CRT display shown in A of Fig. 1, the actual output of the Scope Calibrator project.

If the probe's capacity is set too low there will be an overshoot of the leading edge of the waveform, as illustrated in B of Fig. 1. If the probe's capacity is set too high, it will attenuate the high frequencies, illustrated in C of Fig. 1 by a rounding of the squarewave signal's leading edge.

While it's possible to get in the ballpark with a 60- or 120-Hz squarewave calibration signal derived from the powerline, more convenient and precise adjustment is attained from a 1000-Hz waveform, the usual calibration frequency of *lab-grade* scopes. The output frequency of the Scope Calibrator shown in the schematic diagram and photos is 1000 Hz.

### How accurate

The project is intended to be primarily a junkbox special, and most component parts typically found lying around will be close to the specified output values. For example, the 5-volt output will actually be nominally 4.8 volts. If you adjust the scope's sensitivity so that the outer edges of the trace is 5-volts peak-to-peak, the graticule will be accurate. If you split the graticule lines with the trace you will actually be calibrating to 4.8 or 4.9 volts, depending on the particular transistors used. If you want a precise 5 volts from the center of the trace, substitute two series-connected Zener diodes totalling 5.3 volts for the specified diode, D1 (see Fig. 2).

### Construction

The project shown is built primarily on a printed-circuit board measuring 2-1/2  $\times$  4-7/8-inches, which just fits nicely

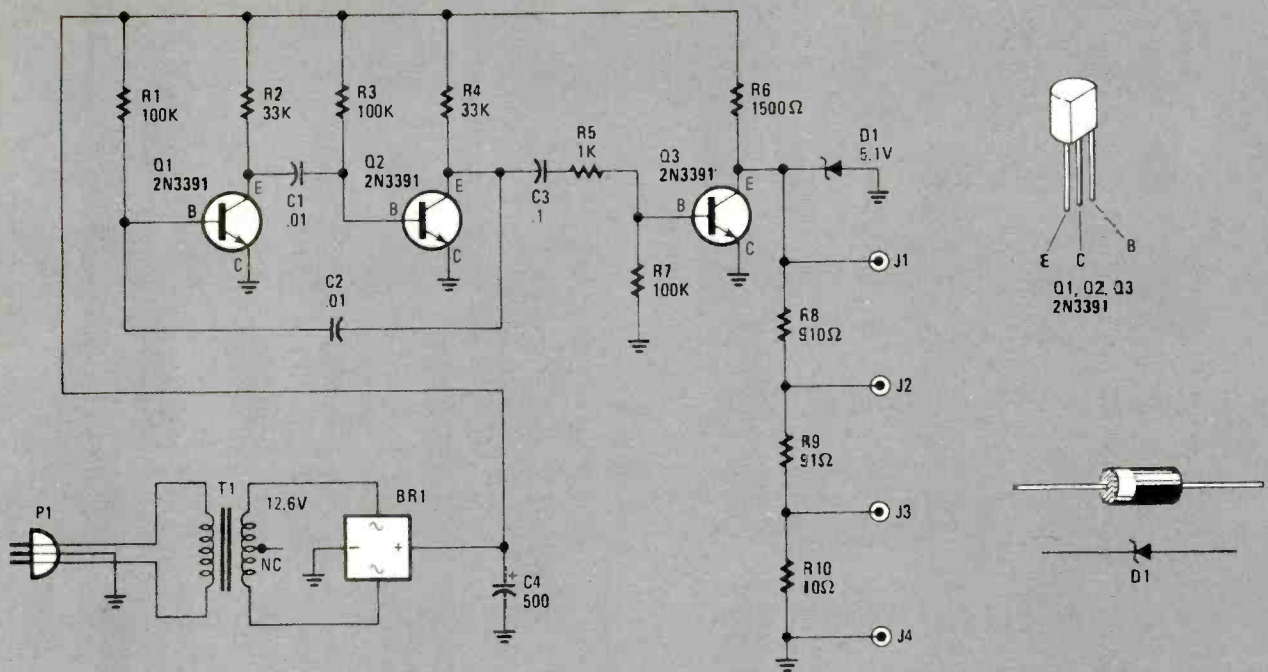
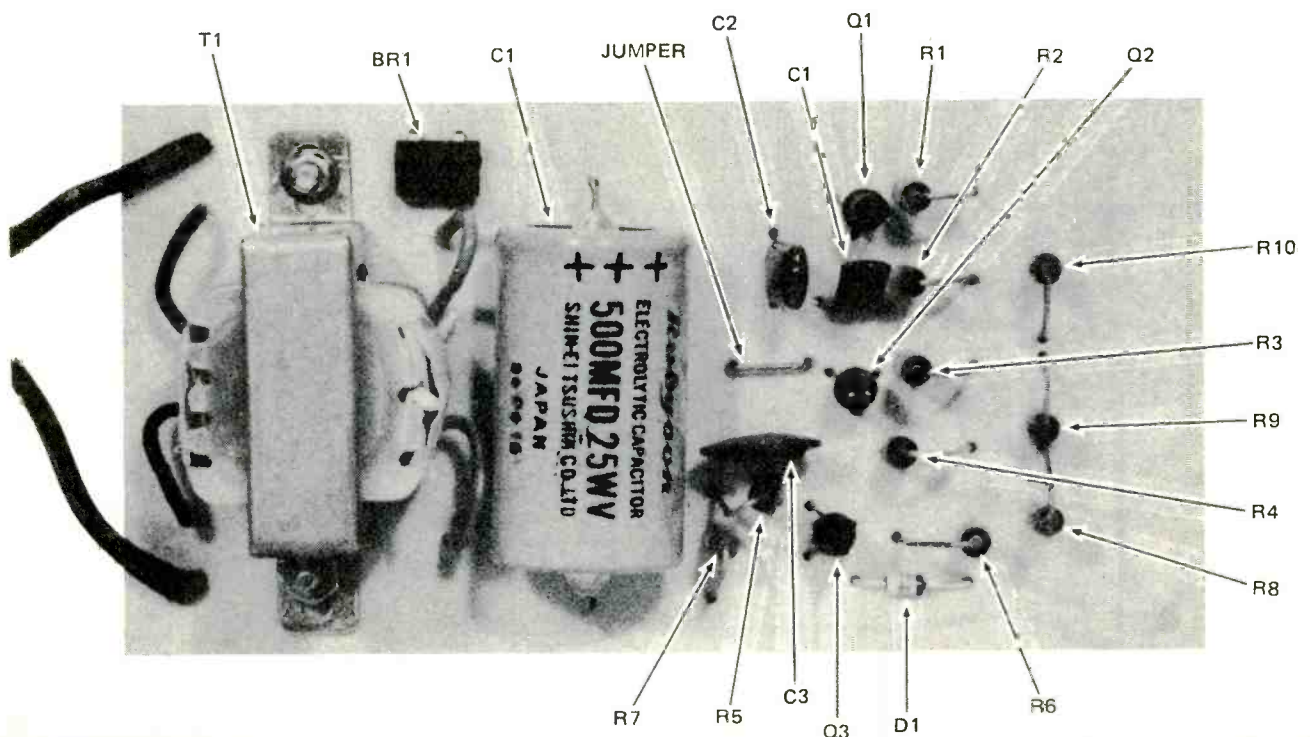

FIG. 2—THE THREE-TRANSISTOR CIRCUIT for the Scope Calibrator consists of a free-running multivibrator stage, Q1-Q2, and a buffer stage, Q3. R8, R9, and R10 are specified as 5% resistors which are sufficient for this circuit.

inside a 3 × 2-1/8 × 5-1/4-inch aluminum LMB cabinet. If the printed-circuit board is larger than the template edges, it will interfere with the installation of the cabinet's cover. The Scope Calibrator's test-voltage outputs are wired to binding posts, J1-J4 (see Fig. 2). Since you're only going to touch the scope's test probe to the calibration voltage, use the least expensive parts—whatever you have lying around. Feel free to substitute pin jacks, banana jacks, or whatever.

Power transformer T1 is rated 12.6 volts at any current; the mini-transformer shown in the photos is rated for 0.1 ampere. Bridge rectifier BR1 can be anything rated 25 PIV or higher. The PC-board layout is for the Radio Shack 276-1161 bridge rectifier. If you substitute any other integrated rectifier, make certain that the printed-circuit connections match. If not, modify the PC template. You can substitute a bridge consisting of four discrete silicon rectifiers, such as the

THE SCOPE CALIBRATOR'S CIRCUIT is assembled on a printed-circuit board for which a same-size template is provided. Note that even power transformer T1 is mounted on the board.





**THE BUSINESS END** of the completed Scope Calibrator. It's only necessary to touch the scope's probe to the test terminal when calibrating the vertical input; hence any kind of terminal can be substituted for the multi-way binding posts, J1-J3.

1N4001 family. Again, modify the printed-circuit template (Fig. 3) accordingly.

Transistors Q1, Q2, and Q3 are the 2N3391 or its equivalent (NPN,  $h_{fe}$  of 300 to 500). The specified transistors have an ECB (not EBC) lead arrangement, make certain they are installed correctly. Some TI and other make transistors may be configured for an EBC lead arrangement depending upon their prefix or suffix designation. So be extremely careful. Holding the printed-circuit board so that you are looking at the component side with Zener diode D1 at the bottom, position Q1 and Q2 so that the "flat" on each transistor faces the bottom (D1). Install Q3, the transistor nearest the bottom of the PC board, so that the flat faces to the right edge. If you substitute transistors make certain the leads are in the correct holes.

Make certain that D1 is installed with the correct polarity: the anode end connects to ground; the cathode end—the one marked with a black band—connects to Q3's collector.

None of the resistors and capacitors need be precision tolerance—the only thing really critical in the project is the output voltage, which is determined by D1 (see Fig. 2). The squarewave output, however, probably won't be symmetrical—or close to symmetrical—if C1 and C2 aren't matched; and they won't be matched, because Mylar-capacitor tolerance is very broad. If you're fussy, and you want squarewaves to look like squarewaves, trim the value of either C1 or C2 by connecting a *test* 0.01-mF capacitor in parallel with one or the other. (Tack-solder the test capacitor to the foil side.) If it makes the condition worse, move the test

capacitor to the other circuit capacitor; for example, if you connected the test capacitor across C1 move it to C2. A few tries should give you a reasonably symmetrical output waveform. For example, the waveform shown, attained using very cheap Mylar-capacitors, required a *marked value* of 0.02- $\mu$ F for C1 and 0.01- $\mu$ F for C2.

To simplify the final assembly, solder four 5-inch insulated leads to the output foils; they will be cut to size after they are connected to the multi-way binding posts J1 through J4. Note that J4 is grounded: it's the *common* or *ground* connection.

The printed-circuit board is installed in the cabinet using 1/4-inch spacers or a stack of washers between the board and cabinet at each of the three mounting screws. Make certain that no component or wire lead sticks through the board and shorts to the metal cabinet—don't depend on the standoffs without checking visually. Note: There is no power switch—none is needed. Simply plug the calibrator in when you need it. It uses virtually no power, so it can be left connected whenever the scope is *on*.

### Using the calibrator

If possible, check the output voltage on a lab-type or quality scope. To calibrate the CRT graticule, connect your oscilloscope's vertical input *ground* or *common* test lead to J4, the *common* or *ground* binding post. Connect the oscilloscope's *hot* test lead to J1, the 5-volt peak-to-peak output. Adjust the oscilloscope's vertical gain so that the waveform fills the number of graticule divisions you want to represent 5 volts. Or, as you may require, use the other calibrator outputs.

To adjust your oscilloscope's low-capacity probe, connect it to any of the calibrator's outputs and adjust the probe's trimmer capacitor or calibration adjustment for a perfect squarewave, as shown in A of Fig. 1. SP

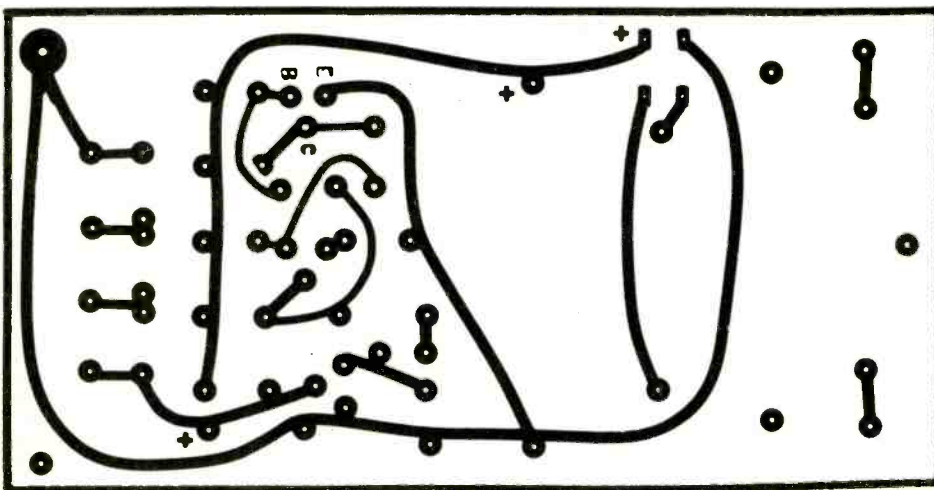

**FIG. 3—BELLY-UP VIEW** of the printed-circuit board foil pattern. Location of parts can be determined from the photographs. Positioning of transistors Q1-Q3 is given in text.

# PRO CABINETS FOR HOMEBREW PROJECTS

***A well-prepared box or cabinet protects the circuit components and encourages the builder to employ the project!***

HERB FRIEDMAN

BACK IN THE EARLY DAYS OF RADIO WHEN GRANDPA WOUND HIS receiver coils around old Quaker-Oats oatmeal boxes, radios were built on wood bases: either the proverbial kitchen breadboard or slabs of mahogany, maple, oak, or anything else with an attractive grain. The wood was usually sanded glass-smooth, and then finished with several layers of stain and hand-rubbed varnish. The finished product was a work of art, often surpassing the appearance of "store bought" equipment—which was also made of wood in them thar' days.

Today, we generally build our homebrew projects in aluminum or plastic cabinets because they are inexpensive materials easily worked with home-workshop tools. But, although metal and plastic don't have the beauty of wood grain, a homebrew project can still be attractive. In fact, spray paint and some decal labels and letters are all that's needed to make a *Plain Jane* homebrew project look like something that came out of a high-technology (*hi-tech*) factory.

To illustrate what can be done for even small junkbox projects, we'll show how the cabinet for the *Scope Calibrator* project (shown elsewhere in this issue) was given a laboratory-instrument appearance. The same procedures can be used for other projects, large or small.

## **Drill all holes and cutouts first**

First step is to select your cabinet and drill the necessary



holes; you want to avoid drilling or cutting the cabinet after it's been painted. When you've decided on the cabinet to use, lay out the cabinet hardware and cut all the necessary holes and openings *cleanly*; nothing looks as sloppy as a beautifully finished project with screws and other hardware hanging half in and half out of oversized holes. If possible, use a drill press (photo 1) and/or chassis punch(s) for the larger openings. If you don't have a drill press at least use an inexpensive, small stand that converts your electric hand drill into a miniature drill press.

For holes  $\frac{5}{16}$ -inch diameter and smaller, a Whitney hand punch (available from the better hardware and tool stores) does a fantastic job on aluminum, PC boards, Bakelite, plastic, or whatever. See photo 2. It leaves a clean, burr-free precision hole. If you need a little extra "oomph" for somewhat heavier metal you can clamp the punch in a vise.

If you're lucky enough to have a decent parts store in your area you might be able to pick up a cabinet prepainted in Hammertone Grey; or you might be able to get a plastic

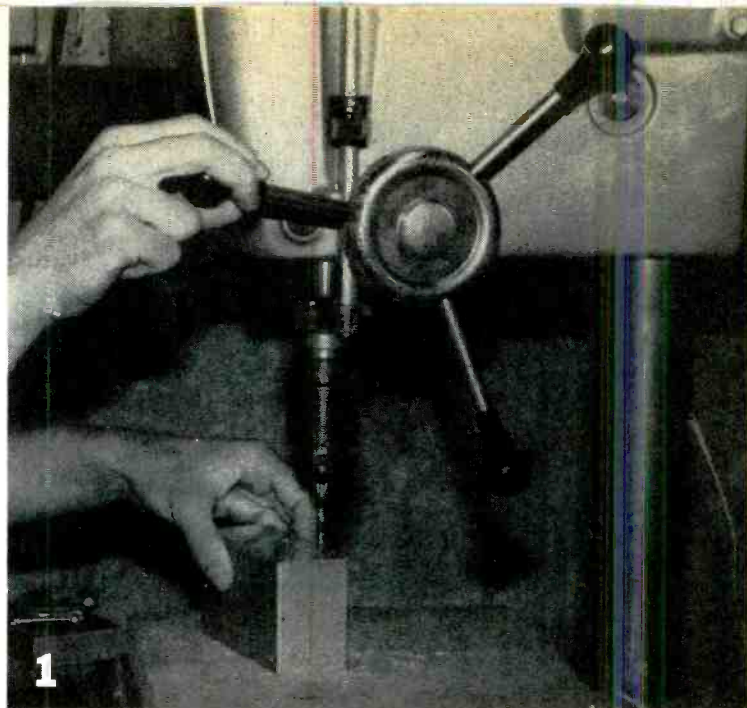

**A PRO CABINET starts out with properly drilled panel holes and openings. You don't want the panel components hanging half in and out of oversized holes. Use a drill press or a stand-mounted hand drill if possible. Be sure to clean out the burrs.**

### Paints also aren't all alike

As for the type of paint to use, you will need at least two of the three products similar to those shown in photo 4. The center product in photo 4 is ordinary spray paint...a somewhat inexpensive "private-brand" paint. Funny thing about the spray paints, price is not necessarily indicative of quality when it comes to adhering to aluminum. I've had no luck with Rustoleum brand paint; it takes several coats to cover. Krylon tends to run or peel, depending on the aluminum and how well it's been scrubbed with steel wool. For single coats I've had best results with cheap "private-brands." If your project is going to get rough handling and you would like the paint to stick like glue, use a *primer* paint as the first coat, it

If you plan on painting the cabinet you can keep the spray paint out of the inside of the cabinet by taping over the holes from the inside. Actually, careful spraying will limit interior paint covering. A surface must be scraped clean later at ground tie points.

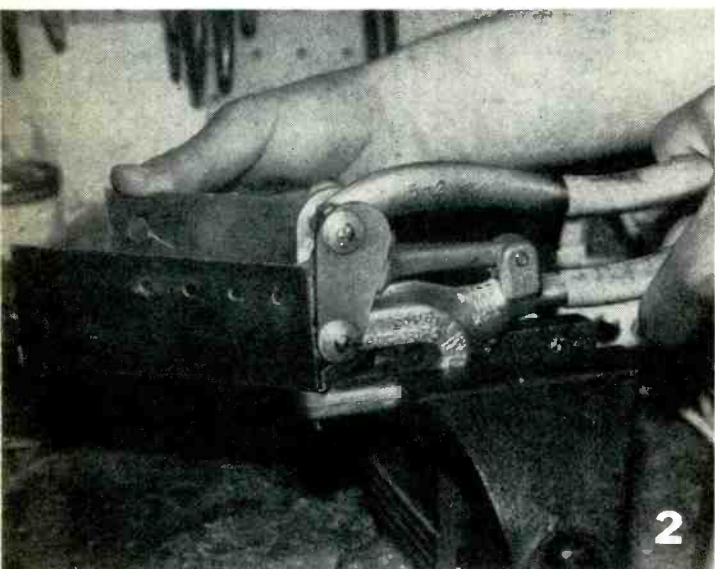

**SMALL HOLES** are punched cleanly and in perfect position with a Whitney hand punch that can be secured in a vise for extra heavy metal. Do not apply pressure to the case as you punch the hole. Punches do not work well on plastic chairs or boxes.

cabinet in the desired color. All you'll have to do to finish these cabinets is add the proper labeling for the panel components. More than likely, however, what's available will be an unpainted aluminum cabinet, or a plastic cabinet in a dull color, and your first step will be to paint the cabinet.

Unfortunately, all aluminum cabinets are not alike. In particular, the aluminum cabinets sold by Radio Shack have some form of coating that detergent and acetone won't remove, and the paint—with its panel markings—flakes off almost as soon as you put it on. You tend to get a better paint adhesion from the BUD, Par Metal and LMB aluminum cabinets. However, whatever you use, wipe it down with a strong detergent and then scrub all surfaces to be painted with a medium to coarse steel wool (available from hardware and paint stores) just before you're ready to paint the cabinet.

If you don't want to get paint inside the cabinet when it's spray painted—you might need a clean surface for a ground connection—cover the opening with a strip of electrical or masking tape from inside the cabinet. See photo 3.

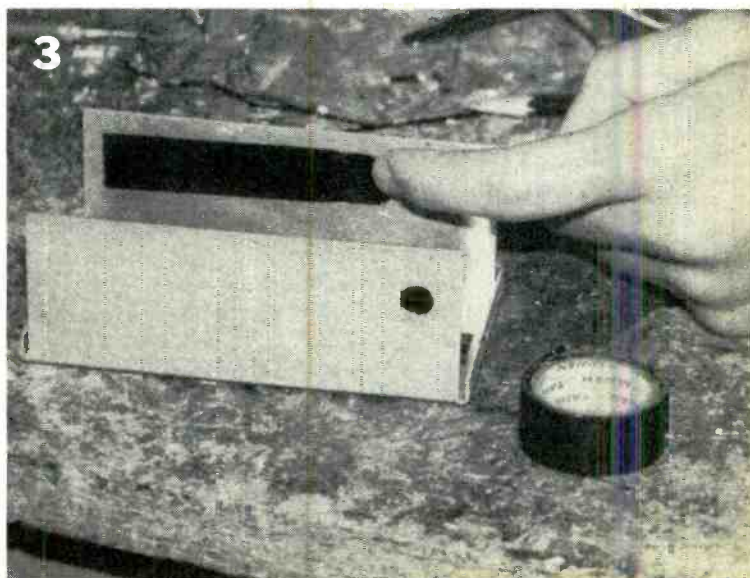

will just take an extra night to finish the paint job. The Krylon Matt-Finish used by artists is an excellent aluminum primer. Apply evenly, but sparingly over the surface.

Another problem with spray enamel paints is that some reject transfer-type panel markings. Many of the better spray enamels have such high-gloss surfaces when they dry that most of the usual materials used by hobbyists to letter panels won't stick. Again, I've had best results with real cheap private-brand spray paints. If you like the colors of "better" paints and insist on their use, you can try applying an overcoat of clear "matte" or "preparation" paint that's sold in art supply stores. The product is made to provide a "tooth" on slick surfaces. Ask your local art supply dealer; he knows of products we electronic hobbyists rarely get to see.

On the left of photo 4 is DATAKOAT matte protective spray, which is used to protect the lettering, etc., that will be applied to the cabinet. This is a clear paint that merges the lettering (which we'll cover later) into the base coat, and it also



4

SPRAY ENAMEL PAINT can in center is an inexpensive kind that works best. The DATAKOAT clear matte spray at left protects markings you apply on the panel. The spray can on the left is artist's protective spray sold in many local art supply houses.



5

TO PREVENT THE SPRAY PAINT from coating everything in the shop make a spray booth from a large cardboard box. Position the cabinet on a wooden block or small box so it can be moved.

USING THE CABINET as a guide make a drawing of how you would like the finished product to look. Indicate the distances from the panel components to the edge of the panel markings to avoid overlaps. Planning ahead makes for a better project!

protects the finish. The stuff is not the easiest thing to locate and you might have to substitute a product similar to the one shown on the right of photo 4, a standard artist's protective non-glossy spray sold in art supply houses. The stuff smells to the heavens when used, but it protects the panel markings. I prefer DATAKOAT, but if you can't get it use whatever is suggested by your local art supply store.

### Spraying

To avoid spraying everything in sight, make yourself a "spray booth" from a large cardboard carton; an egg crate is a good choice. Cut away the front, as shown in photo 5, so you can spray from almost any angle. Place the chassis on a small support—a tray, box, or a scrap chassis salvaged from an old project—and spray lightly with broad sweeping motions. Two thin coats are always better than one thick coat; thick coats tend to run, and crinkle when the paint dries. Two thin coats will come out s-m-o-o-t-h, except—of course—for the dust that settles on the wet paint. If you must turn the cabinet you're spraying turn the support. If you touch the

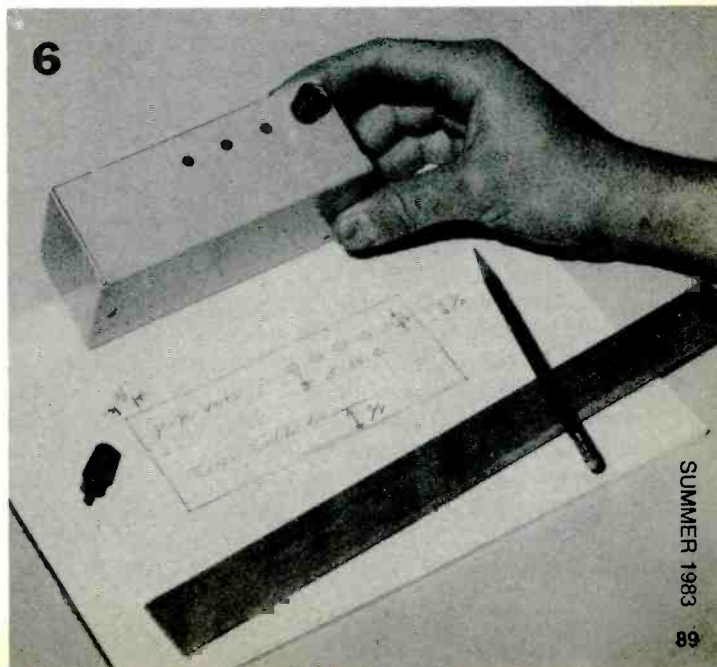

6

**PANEL-MARKING DECALS** are complete phrases, characters or letters on a gelatin base. You cut out the marking you need, soak it in water to float off the paper backing, and transfer to the cabinet.

**ANOTHER FORM OF PANEL MARKING** is transfer or press type. The letters are on the back of a clear plastic sheet. Rubbing the sheet with a burnishing tool causes the wax character to transfer to cabinet.

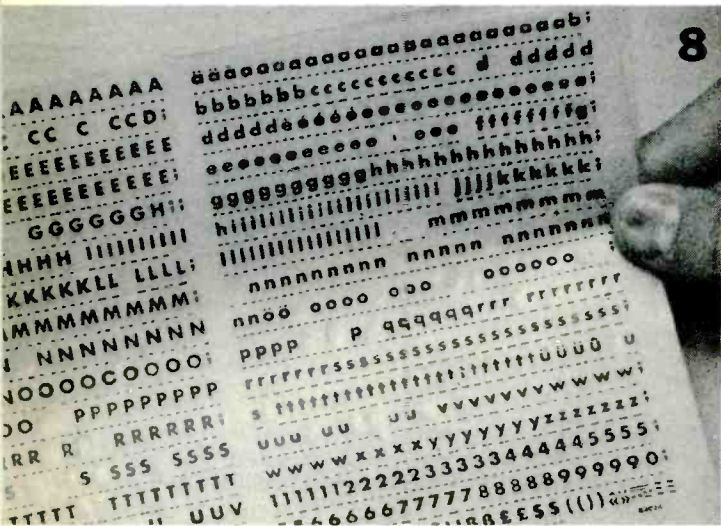

cabinet you'll leave your fingerprints in the paint.

While the paint is drying (allow at least a full 24 hours) refer to the drawing of the panel layout you made prior to drilling the holes. If you did not make a drawing—do so now and indicate all spacing between the components and the panel markings. Use the actual panel components for the measurements; don't guess. Try to keep the drawing to scale. See photo 6. The spacing between the panel markings and the panel components must be accurately indicated in your drawing. Keep in mind that it's difficult to make changes later if you find that some control nut or knob half covers your solidly affixed labels.

Several different products can be used for the panel markings. In the golden age of construction, 1950-1975, most hobbyists used the panel decals shown in photo 7. These were sheets of preprinted standard and not-so-standard panel markings, titles, legends and alphabets. The user cut out the desired marking (as shown in the photograph), soaked the strip in water until the paper backing floated free—leaving the title on a strip of a gelatin-like substance—then placed the strip on the panel. The excess water was squeezed out from under the strip with a cloth, and when the strip dried the marking was permanently affixed to the panel. Of all the various types of panel marking products it's the easiest to handle and apply. The labels were sold under various brands throughout the U.S. The major supplier was G.C. Electronics and Audiotex, though there were many regional brands. The stuff is still available from some electronics parts distributors.

When you need large, big, or giant markings you'll use what's known as *transfer* or *ruboff* type. This consists of a clear plastic sheet with letters or symbols on the back, which transfer to the under surface when rubbed with a stick, ball pen, or burnishing tool. Notice in the sample shown in photo 8 how individual letters have been "used up." As a general rule, transfer type comes in upper (capitals) and lower case sets up to about 20 point. The type you are reading now is 10 point. Larger sizes are available in either all caps or all lower case. There are many different brands available though art supply stores. The best, for electronics experimenter use, is the *Letraset* brand because most of the sizes have a spacing and alignment guide located under each letter on the sheet.

In photo 9 we show how transfer type is applied. The letter is positioned over the painted cabinet and rubbed with a wood stick, pen, or whatever. When the paper is lifted off the letter will remain on the cabinet. Special *Letraset*-style transfer type is available with complete titles for electronics panels. It is applied the same way, except the stick is rubbed over the entire title or word.

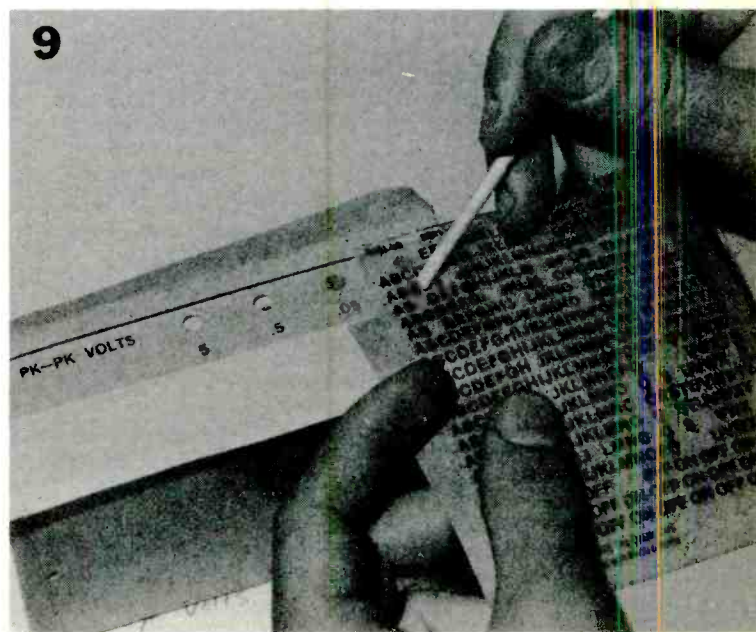

**WHEN USING TRANSFER TYPE** protect as much painted surface as is possible with paper shields. Transfer type tends to come off when you don't want it; and it's difficult to remove.



AN EXTRA SHIELD has been positioned to cover the word "Scope" which precedes "Calibrator." Protect any area that might be covered with the transfer type sheet as you add new markings to the painted cabinet.

Notice the paper "shields" taped to the cabinet in photo 9. Often, unwanted transfer-type symbols will transfer to the cabinet wherever you touch the sheet. The markings that stick with the most tenacity to the painted surface are, of course, the ones that "flake off" accidentally. You simply avoid a good part of the problem with the paper shields; most unwanted markings will flake off on the shields.

Photo 10 better illustrates the user of paper shields. Note the large shield to the left of the word "Calibrator." It covers the word "Scope." Without the shield you would find that "fresh" transfer type sheets might actually lift previously applied markings off the cabinet. Also note the small

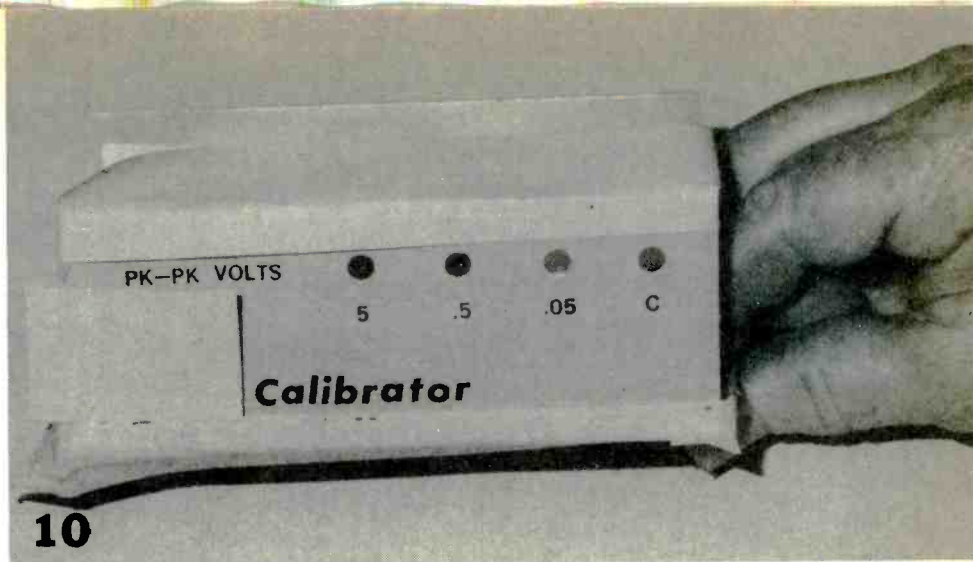

### Making it all permanent

Virtually all panel marking material is very fragile when first applied, though the decals are many times "tougher" than transfer type. Often, just brushing them with your fingers will cause parts of characters, or complete characters, to flake off the cabinet. The markings are made permanent by applying a light coat of DATAKOAT or an artist's protective clear spray. Both products very slightly dissolve panel marking material so it merges either with the cabinet paint or the protective clear spray paint. When it all dries the markings are actually part of the paint coat itself, and are immune to damage from normal handling. See photo 11. You'd have to scrape the paint off the cabinet to remove the markings.

### Customize

Naturally, you probably have your own ideas as to how you would like to customize your projects. We have touched on the basic principles of "decoration"; the precise type of materials you use will depend primarily on what's available in your neck of the woods. Actually, just about anything that will stick to the cabinet until you can get a protective clear coat to hold it down can be used. If you're not certain a product will work try it on a small piece of scrap aluminum, or a cabinet salvaged from an old project. Whatever you try, the key to success is to always be certain the surface is absolutely dry before you work on it. If in doubt, simply wait 24 hours before you apply each coat of paint to the cabinet, or the panel markings, or whatever. **SP**

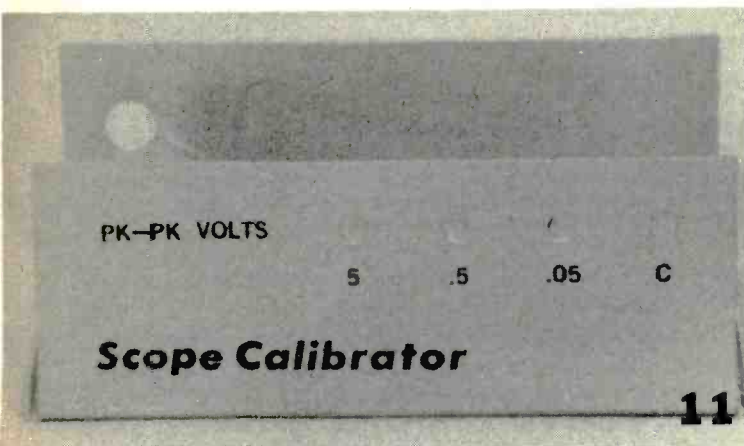

THE FINISHED CABINET'S front panel is now ready for the panel components to be mounted. The cabinet has been sprayed with clear DATAKOAT to protect and secure the panel markings.

"dashes" on the lower shield. They provide the reference line for the larger type used for the word "Calibrator." The dashes, which are the guide marks from the Letraset transfer sheet, are a lot easier to use than juggling a ruler as a straight edge, and better than marking the panel with a China-type grease pencil; grease pencil doesn't always rub off completely, particularly from light color paints.

One word of caution regarding transfer letters and titles. The stuff is very fussy as to what you're trying to stick it on. It will not adhere directly to many of the "greasy" aluminum cabinets, nor to most high-gloss enamel paints; it might not even come off its carrier sheet when rubbed with a stick. As a general rule, the inexpensive paints provide better initial adhesion of transfer type. If you find yourself stuck with a cabinet paint job to which the markings won't stick, apply a very thin coat of matte finish or non-glossy clear paint (such as DATAKOAT) over the paint and let it dry for at least 24 hours. The transfer type will stick like glue to the matte surface.

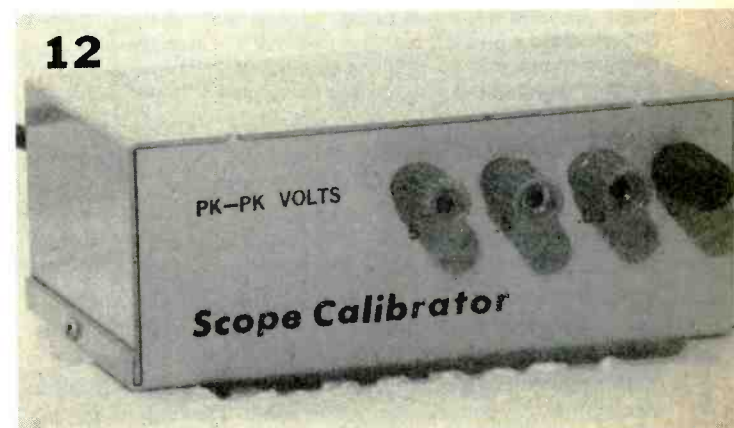

HERE'S WHAT THE FINISHED PROJECT looks like on your test bench. What makes the packaging effort worthwhile is that the home-brew project looks good enough to use, and clearly instructs the user as to its connection and application with other devices. Beauty takes the beast out of your project.

# Extra-Low-Power PILOT LIGHT

***This flashing light tells you that it is time to turn off the power switch!***

BY EVERT FRUITMAN

HOW MANY TIMES HAVE YOU REACHED FOR A PIECE OF battery-operated equipment only to be disappointed upon finding the batteries drained, because someone had forgotten to turn it off? Some kind of pilot light might have saved the day, and the batteries! But a pilot light wasn't used because of the current it consumes. Even a light emitting diode (LED) with a current-limiting resistor, Fig. 1, represents a moderate drain on the battery when compared to the circuit's normal battery load.

Cheer up! The Extra-Low-Power Pilot Light does just what its name implies. It draws very little power from a battery and its periodic flicker serves as a reminder for the user to turn off the portable equipment. Its wide range of operating voltage, (5-30 DC), and small size make it versatile enough to be added to almost any project that might require its use. Of course, it could be added to new equipment too! There is, or was, a LED chip on the market made to do almost the same thing. I ran into three little problems with it. It has a limited voltage range; it was expensive, and it wasn't always available. The first problem was solved with a Zener diode in series with the power-supply line. The last problem was solved with the circuit shown in Fig. 2. The



**FIG. 1—HERE'S A TYPICAL** light-emitting diode (LED) circuit that usually draws approximately 20 milliAmperes. The LED light is on continuously when power is supplied, causing a severe battery drain when left running over night. Often the pilot light consumes more power than the equipment itself would when left on after being used. What a way for a battery to go!

middle problem remained the same unless you salvaged parts from the junkbox—then the price is right.

The circuit, Fig. 2, consists of a simple cross-coupled free-running oscillator with an LED in between the battery and the collector of Q2. As the transistors, Q1 and Q2, are alternately switched on and off, so is LED1. The values of resistance and capacitance are chosen so that minimum current is drawn in the off mode, and LED1 is off longer than it is on during each cycle. An added feature of that design is that electrolytic capacitors are not needed. The values for the resistors specified in the Parts List express a wide range of ohms because the circuit is not too critical, and the experimenter may select those values he currently possesses (different from those in Fig. 2) so that project cost may be kept very low. Also, the chances are that you may be able to

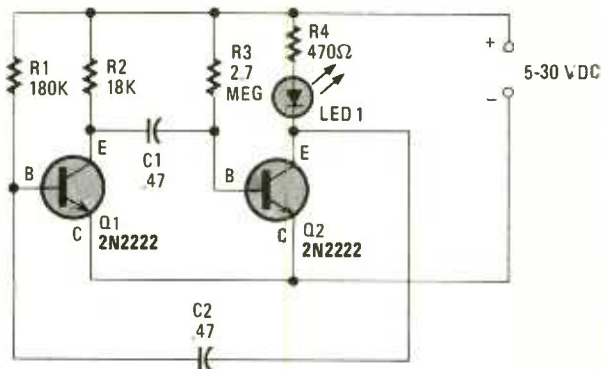

**FIG. 2—THE EXTRA-LOW-POWER PILOT-LIGHT** circuit is nothing more than a free-running multivibrator designed to keep power consumption down—way down! Values are not critical, and most any NPN transistor can be used in this project.

assemble the project this very evening from parts presently in your junkbox.

Typical current drain using a 10-volt power supply runs from less than one-half mA (.5 mA) in the off mode to about 14 mA during the on mode, or light burst. At 5-volts DC the drain is a quarter of a mA (.25 mA) and 3 mA, respectively. The higher the voltage, the faster the Extra-Low-Power Pilot Light blinks. That friendly colorful wink from LED1 (you pick the color) could be enough of a reminder to save you the loss of perfectly good batteries, and the use of valuable equipment when you need them most. **SP**

## PARTS LIST FOR EXTRA-LOW-POWER PILOT LIGHT

- C1, C2—47- $\mu$ F, 50-WVDC disc or tubular capacitor
- LED1—Light-emitting diode, your choice of color
- Q1, Q2—2N3904, 2N2222, ECG123, or most any suitable replacement types of NPN, general-purpose, low-power transistor
- R1—180,000-ohm, 1/4-watt composition resistor
- R2—18,000 to 22,000-ohm, 1/4-watt composition resistor
- R3—1.7 to 4.7-Megohm, 1/4-watt composition resistor
- R4—470 to 620-ohm, 1/4-watt composition resistor

Note: Resistors may be either 20%, 10% or 5% tolerance. Perfboard or printed-circuit board materials, wire, cement, solder, hardware, etc.

# CPP1 CODE PRACTICE PROCESSOR

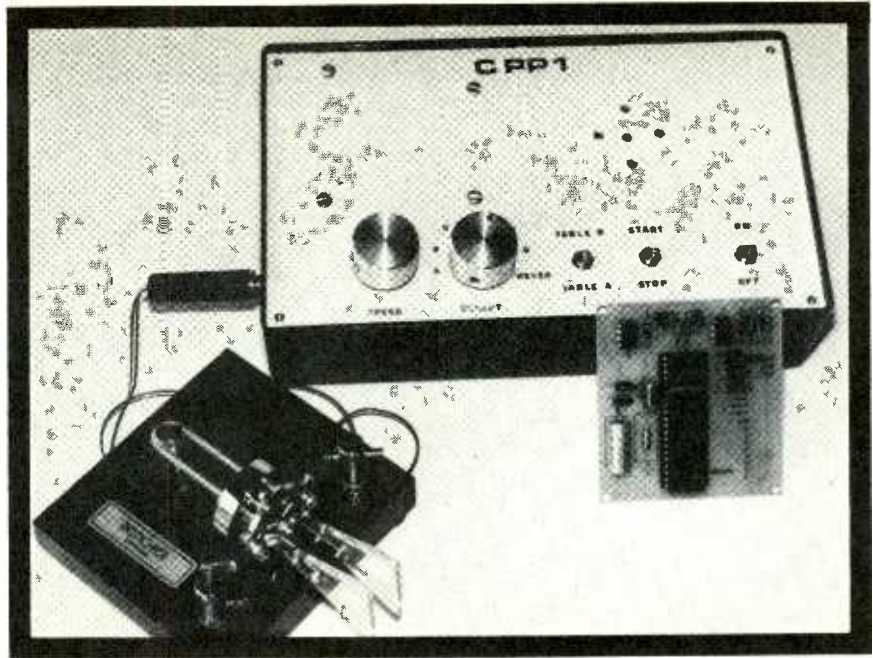

HARRY LATTERMAN

THE FIRST STEP IN ACQUIRING AN AMATEUR RADIO LICENSE is learning the Morse code. For some people, that is but a stepping stone to an exciting world of global communications. To others it is a step into quicksand and they go no farther.

Learning Morse code by traditional means can be more of a frustration than an enjoyable experience. It's hard to find dedicated partners with whom to practice. Using cassettes and records is irritating because of the time consumed searching for a particular practice group. In addition, one's concentration is constantly interrupted by the necessity of rewinding to the beginning of that practice section in order to start over. Also tapes and records never seem to have the right speeds for practicing: They are either too fast, or too slow.

The advent of the microprocessor, however, has taken a lot of potential pain out of learning Morse code. A particular code practice group can be selected and it will repeat automatically until the student feels comfortable while learning the code. But not everyone has the hardware and software knowledge to justify obtaining a personal computer to teach code; and the high cost may be another consideration.

Now there is a simple, low-cost, dedicated microcomputer

for learning Morse code: the CPP1 Code Practice Processor. The CPP1 is a single-chip microcomputer containing copyrighted software specifically tailored to teach Morse code. In addition, the CPP1 doubles as an electronic keyer for added versatility.

## Circuit description

The Code Practice Processor is based around a single-chip, 8-bit microcomputer called the CPP1!—hence, the name of the project! That chip contains RAM, 2K of ROM, I/O ports with specific defined functions, an internal clock, and a reset circuit. Refer to Figs. 1 and 2.

To get IC1 to function requires a crystal (X1) and two capacitors (C1 and C2) connected to pins 2 and 3 of the CPP1. Any series resonant crystal between 1 to 6 MHz may be used. A 3.57-MHz, color-burst crystal is recommended because of its low cost and availability.

Upon powering up, the chip must be reset by holding pin 4 low at least 50 milliseconds. That is accomplished by adding a 1  $\mu$ F capacitor (C3) from pin 4 to ground. An internal 200K resistor will charge capacitor C3 to a high level and allow the chip to run.

***Now you can learn the differences between the Dahs and the Dits and pick up required code speed to get your Amateur Radio ticket***

TABLE A — SELECTABLE CODE PRACTICE SUB-GROUPS

Switch S2 Setting	Code Practice Sub-Groups—S1 Open									
A	E I S H 5 U F									
B	T N D B 6 - K Y									
C	? 2 V 3 4 A R									
D	() C ; X / -- M G									
E	L W P J 1 . "									
F	Z 7 0 0 9 8 : Q									
G	E?LTZ	I2WN()	SVPD7	JOT1A	H3BCJ	654.X	KUAIO	YFR?M	,GVK9	
	A;JQ--	/80EL	-ZBI	Z()7JX	OM9-L	ITNDC	.1"KQ	EBLWP	B4ARV	
	J0Z?2	V35UF	G;8-E	ISH6K	Y,A/	XLCQP	V2FEK	:J-DK	WR?U-	
	6/79N	"LAZ5	8HAM()	T1B40	3;S,Z	01.EB	JVGIY			

**KEYER** Electronic Keyer Option

- hyphen; ? question mark; () parenthesis; ; semicolon
- /fraction bar; -- break; . period; " quotation mark;
- : colon; , comma ]

Selecting a particular practice group is done by first placing switch S1 in either an open (TABLE A) or closed position (TABLE B) position. The microprocessor (IC1) tests that switch first to determine which table to look at. A particular practice sub-group is selected by pulling any one of the pins 28-34 of the CPP1 to ground through SELECT switch S2. By not pulling any pin to ground, one selects an additional sub-group.

If that is done with switch S1 open, and switch S3 is set to

START, IC1 will become an electronic keyer with S2 at KEYER. If switch S1 is closed and S2 is open (set at KEYER) the chip will execute the punctuation practice group. Complete details are given in Tables 1 and 2.

Every character in Morse code is based on a dot time. One dot time "on" is a dot, three dot times "on" is a dash. To produce proper repeatable dot timing with IC1 requires an external one-shot multivibrator, IC2. See Figs. 1 and 2. IC1 will produce a very short pulse from pin 35 of the CPP1 to pin

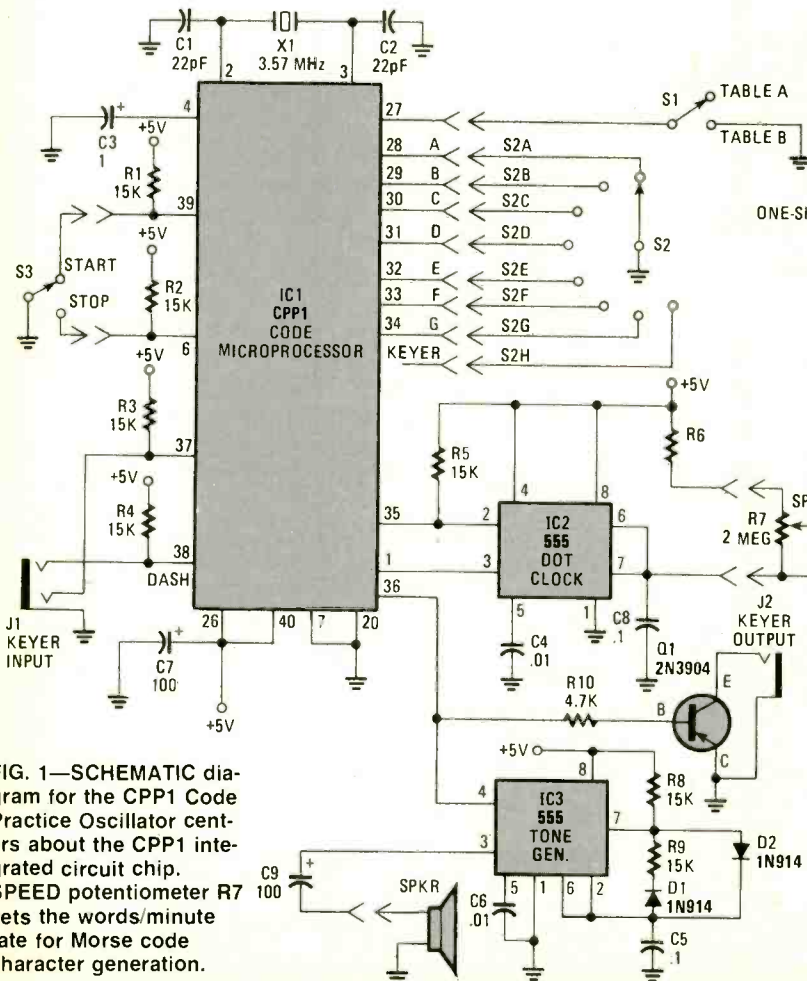
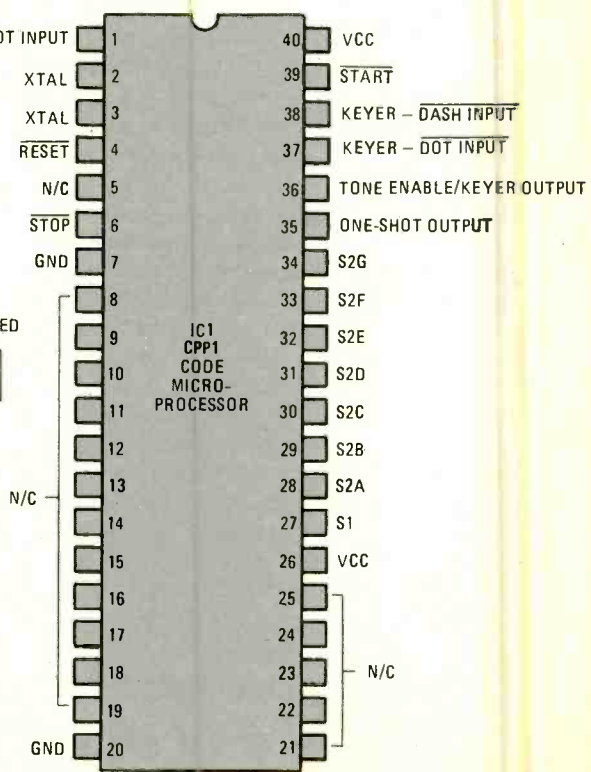

FIG. 1—SCHEMATIC diagram for the CPP1 Code Practice Oscillator centers about the CPP1 integrated circuit chip. SPEED potentiometer R7 sets the words/minute rate for Morse code character generation.

FIG. 2—CPP1 pin terminal signal and power functions are identified here to make circuit-board signal tracing a bit easier. Treat the CPP1 chip as you would a typical CMOS chip—tenderly and with extreme care not to pass a static charge through it.



**TABLE B—SELECTABLE CODE PRACTICE SUB-GROUPS**

Switch S2 Setting	Code Practice Sub-Groups—S1 Closed								
<b>A</b>	HEFSU FUI5E	5IEUH SIFHE	H5EIF 5UESH	USH5H HEFIU	I5SFE FEH5I	EI5S5 USEFI	FEIHS	SUI5F	UEFHE
<b>B</b>	B-YTD BN-TB	N6KBY KYTDN	-KTD6 6-KYD	TYNKD D6YTK	BKNT- YBTND	DY6D- K6NYT	TBDKT	YKTND	-6KYK
<b>C</b>	V4R2A V?A23	?3R42 RAV42	A?VR3 3R2V4	24VA? AVR?2	3A?V3 V4R2V	A23?3 ?RV42	24RAV	RRVV?	43?4A
<b>D</b>	X:( )GC ;-X/C	/--MXG X/( )M;	( )XGCM MXCGM	M/XM-- --X/C/	;C(-)-X GM;/C	CGM--X CXM--G	GXCM-- M;/()X	( )MGX()	
<b>E</b>	J.L1P J"LWP	"WPJ1 LJWP1	LW1." ".JPL	L1JWP 1PWJL	.PJWL LJ"P1	P1"PL W.1JP	1J.WW	LPJ1W	.WL1J
<b>F</b>	0;ZO 07ZO	798Q; ZOQ9;	ZQO87 Q.9:Z	O9;.8 9OZ70	.OQ9Z QZ0.9	0:78Z 807,Q	ZQ8,9	.80:Q	:9Q9O
<b>G</b>	92837 53751	46510	49628	53709	96821	13579	25680	95062	13467
<b>KEYER</b>	;-"/ ( )'-?	-()?	-;-	( )':	;-?'	?()':	-;-	:( ):	?'-/

2 of IC2. The software will then test for the one-shot to time out by testing pin 3 of IC2 through pin 1 of the IC1. If, for example, a dash is being sent IC1 will first turn on the 500-Hertz tone generator by pulling pin 4 of IC3 high through pin 36 of the IC1. IC1 will next trigger IC2 and wait for it to time out. It will do that three times. After the third time it will turn the tone off by pulling pin 4 of IC3 low again. The actual dot timing is based on fixed resistor R6, SPEED potentiometer R7, and capacitor C8.

Pulling pin 39 to ground through, START/STOP switch S3 will start the practice sequence or start the electronic keyer function, if selected. Pulling pin 6 to ground through START/STOP switch S3 will stop the practice sequence. To leave the keyer mode requires powering down of IC1. This can be done with a simple ON/OFF switch in the power supply circuit.

Two jacks are provided (See Fig. 1) for connection to external circuits. KEYER INPUT jack J1 is a standard stereo-type jack. The DOT circuit connects to either hot contact and the DASH circuit connects to the other hot contact. The ground connection is the shaft/panel contact and need not be isolated from ground. KEYER OUTPUT jack J2 can be any

audio or polarizes two-terminal jack with one lead used as the hot or signal lead and the other is the ground return circuit.

### Construction

The circuit has been tailored to be straightforward enough to be constructed by a beginner in just one evening. All of the parts except the CPPI chip are available at any electronics parts house.

Parts layout is not critical. As a general rule the crystal and associated capacitors C1 and C2 should be located as close as possible to the IC1. An additional caution: Capacitor C7 should not be omitted. That capacitor will prevent the processor from being glitched when the tone is activated.

Figs. 3 and 4 show a same-size foil pattern and parts location drawing for a small printed-circuit board that can be used. Capacitor C7 is located off the board either at the battery or at the power supply.

Powering up with regulated 5-volts DC is a simple matter.

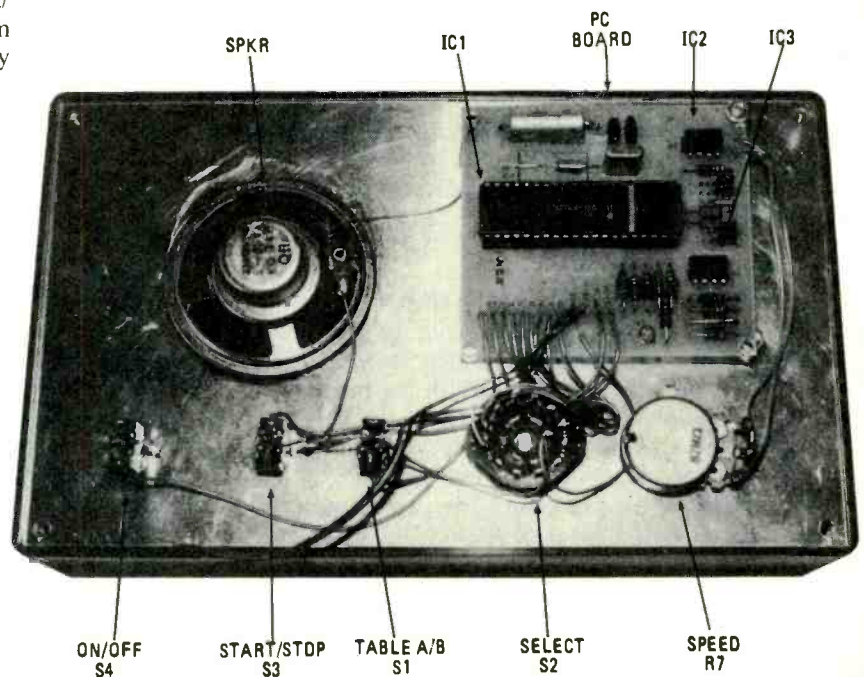

BY POSITIONING THE PARTS in line with some relationship to the printed-circuit board, you will be able to keep lead lengths short and uncluttered. Actually, wiring is not critical, but pride in construction dominates here.

**TABLE C—INTERNATIONAL MORSE CODE**

A — · —	N — — ·	1 · — — — —
B — · · ·	O — — — —	2 · · — — —
C — · — ·	P · — — ·	3 · · · — —
D — · · ·	Q — · — —	4 · · · · —
E ·	R · — · ·	5 · · · · ·
F · · · ·	S · · ·	6 — · · · ·
G — — ·	T —	7 — — · · ·
H · · · ·	U · · —	8 — — — · ·
I · ·	V · · · —	9 — — — — ·
J · — — —	W · — · —	0 — — — — —
K — — —	X — · — —	
L · — · ·	Y — — — —	
M — — —	Z — · · · ·	

· (period)	· — · — ·
, (comma)	— · — — —
? (question mark) (IMI)	· · — · · ·
/ (fraction bar)	— · · · ·
: (colon)	— — — · · ·
; (semicolon)	— · — · · ·
( (parenthesis)	— · — — —
) (parenthesis)	— — — · —
' (apostrophe) (WG)	· — — — — ·
- (hyphen or dash) (DU)	— · · · · —
\$ (dollar sign) (VU)	· · · — — ·
" (quotation mark open)	· — · · —
" (quotation mark close)	· — · · ·
Error sign (8 dots)	· · · · · ·
Separation indicator (BT)	— · · · —
End of transmission (AR)	· — · · ·
Invitation to transmit	— · —
Wait (AS)	· — · · ·
End of work (SK)	· · · — —
Starting signal	— · — — —

Tap off what you need from a bench-top power supply or steal some from another project. Of course, there are those who want a complete project with internal power source. To the latter we suggest you look at Fig. 5 which offers a straight forward line-isolated circuit that will do the job. This circuit is optional and the parts for it are not specified in the Parts List. The advantage of the 7805 chip is that it's exactly 5-volts DC which makes the circuit safer to use than adjustable types that can be incorrectly set and destroy the CPP1 chip, IC1. Consider heat-sinking the 7805 integrated-circuit chip as a precautionary measure.

**Operation**

Using the CPP1 is quite painless. Table A contains the code practice tables for switch S1 being open; Table B contains the code practice table for switch S1 being closed. Table C gives the "dits" and "dahs" of the International Morse Code.

First, determine which practice table you want and set switch S1 to either an OPEN or CLOSED position. Turning power on will reset the processor. Then set S3 at START. Adjust R7 for a comfortable code speed. The selected subgroup will continue until S3 is set at STOP. That's all there is to it!

Determining code speed can be done in one of two ways. The simplest way is to go to the keyer mode and press START. Hold the dot input to ground, pin 37, and count the dots for one second. Take the number of dots counted and multiply it

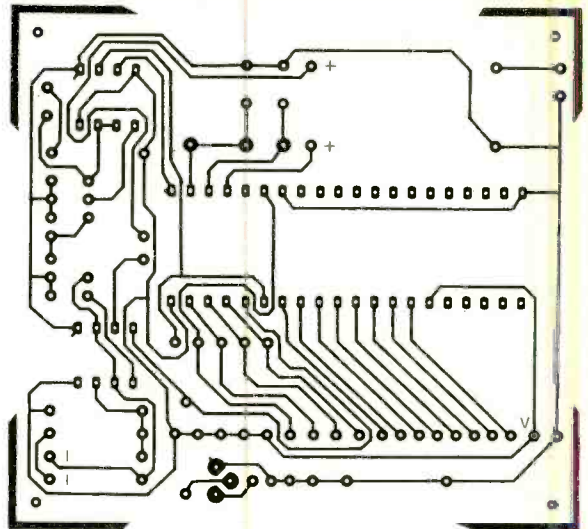

FIG. 3—FOIL-SIDE LAYOUT of the printed-circuit board is shown here actual size. Considering the number of closely spaced wires, it is wise to go the PC board route.

**PARTS LIST FOR CPP1**

**SEMICONDUCTORS**

- D1, D2—1N914 silicon switching diode
- IC1—CPP1 code practice processor integrated circuit
- IC2-IC3—555 timer integrated circuit

**RESISTORS**

- R1-5, R8-9—15,000-ohm, 1/4-watt
- R6—220,000-ohm, 1/4-watt
- R7—2-Megohm potentiometer

**CAPACITORS**

All capacitors rated at 10 WVDC

- C1, C2—22-pF ceramic disk
- C3—1-μF electrolytic
- C4, C6—.1-μF
- C5, C8—.1-μF
- C7, C9—100-μF electrolytic

**ADDITIONAL PARTS AND MATERIALS**

- J1—Stereo jack for phone plug input
- S1, S3—SPST toggle switch
- S2—8-position, single pole rotary switch, non-shorting type
- SPKR—8-ohm 2-3-inch PM loudspeaker
- X1—3.57-MHz crystal (1 to 6 MHz usable)
- Printed circuit board, cabinet or case, 2 knobs for control shafts, wire, solder, 5-volt power supply, etc.

**KEYER OPTION**

- J2—Phone jack
- Q1—2N3904 NPN silicon transistor
- R10—4700, 1/4-watt composition resistor

The CPP1, Code Practice Processor Chip is available from Micro Digital Technology, PO Box 1139, Mesa, AZ 85201 for \$19.95 postpaid. The printed-circuit board sells for \$5.00 postpaid. Checks, VISA, and Mastercard accepted. On credit card orders please include card number, expiration date, telephone number and full name. Phone orders call 1-602/897-2534.

Complete kit of parts, less case, are available from Greenbrier Marketing International Inc. 509 S. 48th St. Suite 105, Tempe, AZ 85201. Priced, \$49.95 postpaid.

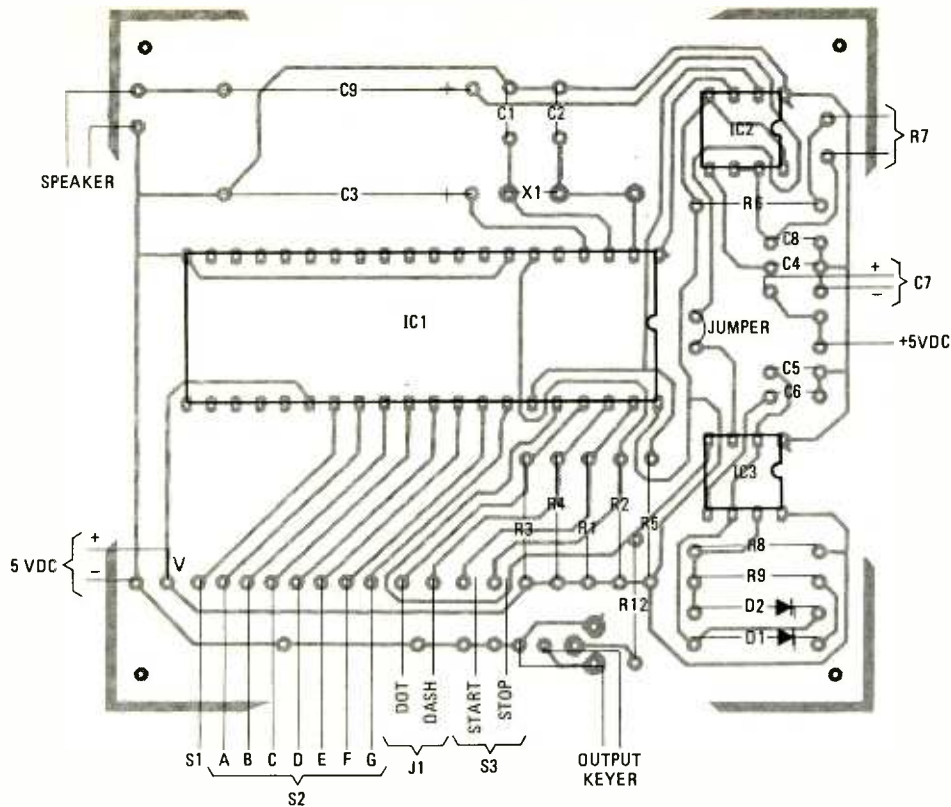

FIG. 4—YOU SHOULD EXPERIENCE almost no trouble dropping component parts into the correct connection holes on the PC board. More than enough room is supplied should your electrolytic capacitors be larger than usual for the parts values specified

by 2.4 to get the number of words per minute. Example:  $2.4 \times 5 \text{ dots/sec} = 12 \text{ WPM}$ . This technique will be a lot easier by using a longer time period (say 5 to 10 seconds) and counting the dots with the aid of a digital-counter device.

Another method to determine dot time, and to set up a predetermined speed, is to replace potentiometer R7 with a rotary switch and fix resistors. To determine a specific dot time use the following formula;

$$\text{DOT} = 1.1 (R6 + R7) (C8).$$

Knowing the dot time speed can be determined by the following additional formula:  $\text{SPEED} = (\text{dots/min})/2.5$ .

The electronic keyer feature is another useful aspect of the CPP1. When switch S1 is open (TABLE A) and position h of switch S2 (KEYER) is selected, the software goes to the keyer mode when S3 is set at START.

In that mode whenever pin 37 is pulled to ground, a series of evenly-timed dots are sent. When pin 38 is pulled to ground a evenly-timed series of dashes are sent. Finally, if both pins 37 and 38 are pulled to ground a series of evenly timed dots and alternating dashes are sent. Those features are generally found only in high-priced electronic keyers.

The speed of the dots and dashes are determined by the dot

clock. The software always maintains a perfect 3:1 ratio at any speed. That is ideal code.

By connecting a transistor to pin 36 of the CPP1 it is possible to turn on and off a relay connected to a transmitter. Since IC3 is also connected, a side tone is also available.

### Conclusion

The CPP1 Code Practice Processor is a very powerful tool for the person just starting to learn Morse code, or for those who are trying to increase their speed. Practicing 15 to 30 minutes a day is all that will be necessary to learn the Morse code.

However, as with any learning experience, to become really proficient, there is no substitute for practice. It is advisable to practice with the CPP1, then listen to an actual Amateurbands right away. That will reinforce your learning experience. At first only freshly memorized letters will be recognized; but in a short period of time whole conversations will be copied with ease. In no time, you will be ready for your Radio Amateur license.

SP

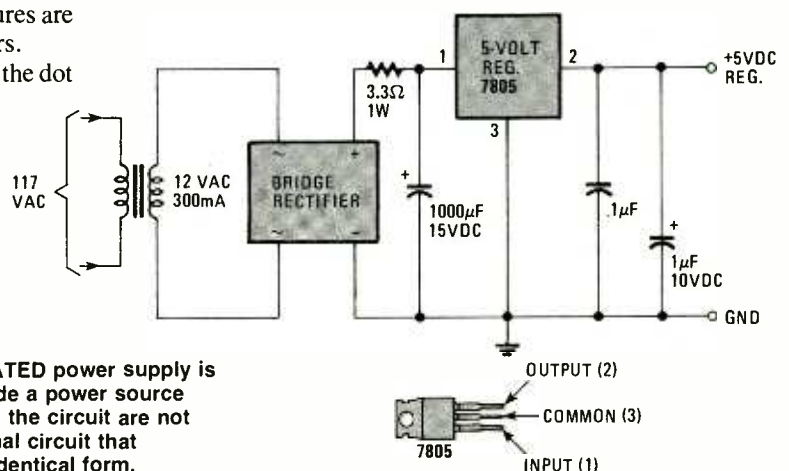

FIG. 5—A TYPICAL 5-VOLT DC REGULATED power supply is given here for readers who like to include a power source with the project. The parts identified in the circuit are not listed in the Parts List. This is an optional circuit that appeared in previous issues in almost identical form.

# 455-kHz BFO

**Here's a simple crystal-oscillator/count-down circuit that helps you tune to the carrier with accuracy.**

LES KUHN

TUNING A DIGITAL-DISPLAY RECEIVER FOR A STATION ON A known frequency is a simple operation. Determining the exact frequency of an unknown station isn't necessarily that easy. It is a test of operator skill to find the center of the received signal. An AM station's very strong signal is audible for several thousands of Hertz on either side of its carrier frequency. Sometimes more! On a receiver, you tune for highest S-meter reading and/or best audio fidelity. For an AM station's signal that is weak, rapidly fading, or suffering from strong interference, that tuning procedure is difficult to do. By mixing, or "beating", the output of the 455-kHz BFO (Beat-Frequency Oscillator) with the station's intermediate-frequency (IF) carrier signal, you can tune rapidly to the exact station's carrier frequency.

And as a bonus, if you already have not guessed, the 455-kHz BFO comes in very handy for tuning in CW stations, and providing the missing carrier for SSB and DSB stations that sound like monkey talk without this handy gadget.

## Circuit operation

Fig. 1 is a schematic diagram of the circuit for the 455-kHz BFO. Transistor Q1 is a 3.65-MHz crystal-controlled oscil-

lator. The oscillator output is coupled to IC1 and IC2 which are 4027 CMOS dual JK flip-flop integrated circuits used as divide-by-two flip-flops. The output at pin 1 of IC2 is a 455-kHz squarewave. The output frequency may be adjusted slightly by changing the value of capacitor C1. If you have a frequency counter available, you may want to substitute a variable capacitor for the fixed 300-pF capacitor.

## Inside the 4027

The dual JK flip-flop integrated-circuit chip is a low-current CMOS device used in this project to divide the input clock signal from the 3.64-MHz oscillator circuit by 2 in three separate steps to produce the 455-kHz squarewave output. Each flip-flop is used independently in the clock mode, which requires that pins 4, 7, 9, and 12 be grounded. Pin 8 is the chip's power and signal ground circuits to the power supply. Inputs to the J and K pins decide what the flip-flop is going to do.

In this project both the J and K pins are tied to +9 VDC so that the flip-flop outputs alternate from +9 VDC to zero volts. The positive edge of the 3.64-MHz clock signal to pin 3 of IC1 causes the flip-flop to change its state at pin 1, say





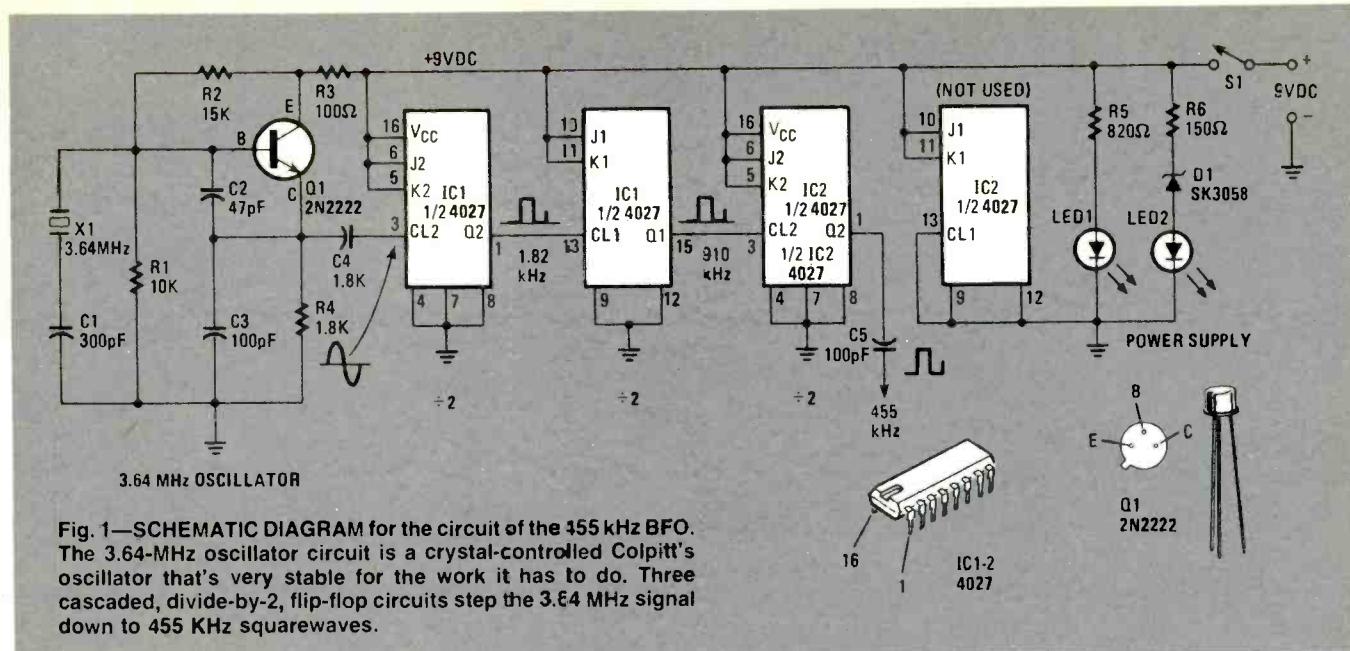

Fig. 1—SCHEMATIC DIAGRAM for the circuit of the 455 kHz BFO. The 3.64-MHz oscillator circuit is a crystal-controlled Colpitt's oscillator that's very stable for the work it has to do. Three cascaded, divide-by-2, flip-flop circuits step the 3.64 MHz signal down to 455 KHz squarewaves.

from low to high. The next positive edge of the clock signal causes the flip-flop to change its state again. Thus, for every two cycles of input signal at pin 3, one cycle of an output squarewave is produced at pin 1—effectively dividing the input frequency by 2. The same occurs at pin 13 and 15, respectively, for the other flip-flop in the 4027.

The circuit draws little current and is usually on for only short periods; a 9-volt transistor battery is used for power. As the battery ages, the voltage drops and lowers the oscillator's output frequency. To alert the user, a low-voltage detector was built into the 455-KHz BFO. When LED1 and LED2 are of equal intensity, the battery voltage is usable. As the voltage drops, LED2 begins to dim rapidly as the voltage across D1 falls below the Zener's rated breakdown potential, and the current passing through R6, D1, and LED2 decreases. It is easy to detect a decrease in battery voltage before there is a detectable change in output frequency.

The circuit is built on a small piece of scrap perfboard. Point-to-point wiring works nicely, or a simple printed-circuit board may be designed and etched. Layout is not critical. Keep all leads as short as possible.

### Using it

The 455-kHz output signal must be coupled *loosely* to the receiver's 455-kHz intermediate-frequency amplifier section. To do that, begin by removing the receiver's top cover. Tune your receiver to a local station and move the 455-kHz BFO output wire across the receiver's circuit board. That wire is insulated and must not make electrical contact! Signal transfer is by capacitive coupling. When the wire comes near the 455-kHz IF circuit, a "beat" note or whistler should be heard in the receiver's audio output. Secure the wire with masking tape in a position to give the receiver a comfortably loud beat note.

To determine the station's exact frequency, tune the receiver for a zero beat. A zero-beat signal cannot be heard! However, as you rock the receiver's tuning knob from side to side, the whistling tone will reappear. Record the receiver's frequency display at the zero-beat position. It must be remembered that the BFO output mixes with the IF carrier signal, which is present all the time when an AM station is tuned properly. A non-carrier signal, such as a SSB with suppressed carrier, will not work with this device. **SP**

### PARTS LIST FOR 455-kHz BFO

#### SEMICONDUCTORS

- D1—6.2-volt, 1-watt Zener diode, RCA SK3058 or equivalent
- IC1-2—4027 CMOS dual JK flip-flop integrated circuit
- LED1-2—Light-emitting diode, semiminature, red diffused lens
- Q1—2N2222 NPN silicon transistor; or SK3444, 2N2222A, 2N2218, 2N2219, 2N5581, or 2N5582

#### RESISTORS

- All resistors are fixed-value, composition, 1/2-watt types
- R1—10,000-ohm
  - R2—15,000-ohm
  - R3—100-ohm
  - R4—1800-ohm
  - R5—820-ohm
  - R6—150-ohm

#### CAPACITORS

- C1—300-pF ceramic or silver-mica, 5% NPD (use two 150-pF or three 100-pF units in parallel if necessary)
- C2—47-pF ceramic or silver-mica, 5%, NPO
- C3—100-pF ceramic or silver-mica, 5%, NPO
- C4-C5—100-pF disc

#### ADDITIONAL PARTS AND MATERIALS

- S1—SPST toggle switch, miniature type
- \*X1—3.64-MHz crystal, ICM type 031300 (\$6.88)
- \*1—crystal socket, type F-605, ICM type 035008 (\$.51)
- IC sockets for wire-wrap connection, battery clip, hardware utility box, perfboard scrap, wire, solder, etc

\* Available from International Crystal Manufacturing Co., Inc., 10 North Lee Street, Oklahoma City, Oklahoma 73102. Write to ICM to confirm prices, availability, and shipping costs.

# Electronics Paperback Books

## Quality Paperbacks at Affordable Prices

### BUY 12 PAY FOR 10—TAKE 2 FREE!



- 30 SOLDERLESS BREADBOARD PROJECTS BOOK-1.** \$5.75. Whenever possible the same parts are used in several projects. Even a first-time builder can complete these circuits.
- HOW TO GET YOUR ELECTRONIC PROJECTS WORKING.** \$5.00. Helps you troubleshoot and repair home-built projects of every description.
- MINI-MATRIX BOARD PROJECTS.** \$5.00. A variety of projects that can all be built upon a mini-matrix board that has 10 strips and is 24 holes long.
- MODERN OP-AMP PROJECTS.** \$5.00. Wide range of specialized op-amp circuits including lo-noise, lo-distortion, ultra-hi input impedance, etc.
- MULTI-CIRCUIT BOARD PROJECTS.** \$5.00. 21 fairly simple projects that can all be built on a single printed-circuit board. All are powered by a 9V battery.
- IC PROJECTS FOR BEGINNERS.** \$5.00. Inexpensive digital and linear IC's are used to assemble this selection of circuits intended for the beginner.



- ART OF PROGRAMMING THE 1K ZX81.** \$6.25. Topics include full screen, scrolling, PEEK & POKE, plus actual working programs.
- THE 6809 COMPANION.** \$5.00. Written for the average assembly language programmer. A discussion of 6809 features & reference work for the 6809 programmer.
- PRACTICAL COMPUTER EXPERIMENTS.** \$4.50. Fills in background to microprocessor by constructing typical computer circuits using discrete logic components.
- ART OF PROGRAMMING THE 1K ZX81.** \$5.00. How to use the features of the ZX81 in programs that fit the 1K machine and are still fun to use.
- INTRODUCTION TO BASIC PROGRAMMING TECHNIQUES.** \$5.00. Based on author's own experience in learning BASIC and helping others to learn to program.
- A MICROPROCESSOR PRIMER.** \$4.50. Painless approach to computing for the beginner. Step-by-step explains computer operations and assembly.

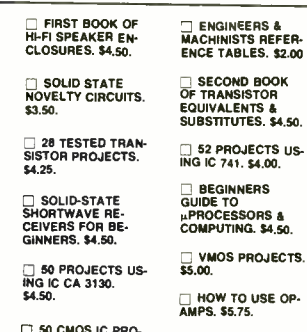

- FIRST BOOK OF HI-FI SPEAKER ENCLOSURES.** \$4.50.
- SOLID STATE NOVELTY CIRCUITS.** \$3.50.
- 28 TESTED TRANSISTOR PROJECTS.** \$4.25.
- SOLID-STATE SHORTWAVE RECEIVERS FOR BEGINNERS.** \$4.50.
- 50 PROJECTS USING IC CA 3130.** \$4.50.
- 50 CMOS IC PROJECTS.** \$4.50.
- ENGINEERS & MACHINISTS REFERENCE TABLES.** \$2.00.
- SECOND BOOK OF TRANSISTOR EQUIVALENTS & SUBSTITUTES.** \$4.50.
- 52 PROJECTS USING IC 741.** \$4.00.
- BEGINNERS GUIDE TO MICROPROCESSORS & COMPUTING.** \$4.50.
- VMOS PROJECTS.** \$5.00.
- HOW TO USE OP-AMPS.** \$5.75.
- AUDIO PROJECTS.** \$5.00.
- MODEL RAILWAY PROJECTS.** \$5.00.
- CB PROJECTS.** \$5.00.
- HOW TO GET YOUR ELECTRONIC PROJECTS WORKING.** \$5.00.
- MULTI-CIRCUIT BOARD PROJECTS.** \$5.00.
- ELECTRONICS SIMPLIFIED CRYSTAL SET CONSTRUCTION.** \$4.50.
- ELECTRONIC HOUSEHOLD PROJECTS.** \$4.50.



- POWER SUPPLY PROJECTS.** \$4.50. Contains designs and construction details for almost any power supply the experimenter is likely to need.
- ELECTRONIC PROJECTS USING SOLAR CELLS.** \$5.00. Simple circuits that have numerous applications around the home.
- ELECTRONIC TIMER PROJECTS.** \$5.00. Timing circuits for almost any application the experimenter might need. A most valuable reference.
- COUNTER DRIVER & NUMERICAL-DISPLAY PROJECTS.** \$4.50. Features applications & projects using various types of numerical-display devices.
- REMOTE CONTROL PROJECTS.** \$5.00. Radio-control infra-red, visible light, & ultrasonic systems are all included, along with methods of applying them.
- ELECTRONIC TEST EQUIPMENT CONSTRUCTION.** \$4.50. Construction details of a wide range of test equipment the experimenter can build at home.



- PRACTICAL ELECTRONIC CALCULATIONS AND FORMULAE.** \$7.50. A basic reference work that bridges the gap between complicated technical theory & cut and tried methods.
- HOW TO MAKE WALKIE TALKIES.** \$5.00. Describes equipment for low-power handheld operation. 112 pages of must reading for the dedicated experimenter.
- INTERNATIONAL DIODE EQUIVALENTS GUIDE.** \$5.75. Helps you find substitutes for the many different types of semiconductor diodes in use today.
- INTERNATIONAL TRANSISTOR EQUIVALENTS GUIDE.** \$7.50. Products of more than 100 manufacturers are listed & cross-referenced with possible replacements.
- ELECTRONIC CALCULATOR USERS HANDBOOK.** \$3.95. Presents formulae data, methods of calculator, conversion factors & more from the view of the calculator user.
- LINEAR IC EQUIVALENTS AND PIN CONNECTIONS.** \$8.25. Shows equivalents & pin connections of a popular user-oriented selection of linear ICs.
- ELECTRONIC SYNTHESIZER PROJECTS.** \$4.50.
- 50 CIRCUITS USING GERMANIUM, SILICON & ZENER DIODES.** \$3.75.
- 50 PROJECTS USING RELAYS, SCR'S & TRIACS.** \$5.00.
- 50 (FET) FIELD-EFFECT TRANSISTOR PROJECTS.** \$4.50.
- 50 SIMPLE LED CIRCUITS.** \$4.25.
- 50 CIRCUITS USING 7400 SERIES IC'S.** \$4.50.
- 50 SIMPLE LED CIRCUITS BOOK 2.** \$3.95.
- PROJECTS USING 555 IC'S.** \$5.00.
- PROJECTS USING LM3900 IC'S.** \$4.75.
- RADIO CONTROL FOR BEGINNERS.** \$4.50.
- ELECTRONIC GAMES.** \$4.50.
- SINGLE IC PROJECTS.** \$4.25.
- RADIO CIRCUITS USING IC'S.** \$4.50.

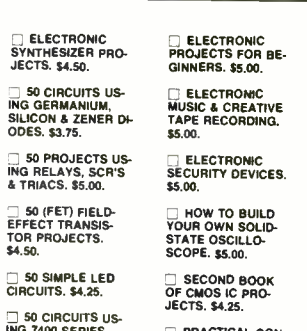

- ELECTRONIC PROJECTS FOR BEGINNERS.** \$5.00.
- ELECTRONIC MUSIC & CREATIVE TAPE RECORDING.** \$5.00.
- ELECTRONIC SECURITY DEVICES.** \$5.00.
- HOW TO BUILD YOUR OWN SOLID-STATE OSCILLOSCOPE.** \$5.00.
- SECOND BOOK OF CMOS IC PROJECTS.** \$4.25.
- PRACTICAL CONSTRUCTION OF PRE-AMPS, TONE CONTROLS, FILTERS AND ATTENUATORS.** \$3.75.
- BEGINNERS GUIDE TO DIGITAL TECHNIQUES.** \$3.75.
- ELECTRONIC HOUSEHOLD PROJECTS.** \$4.50.
- ELECTRONIC MUSIC PROJECTS.** \$4.50.
- POPULAR ELECTRONIC PROJECTS.** \$3.75.
- PROJECTS IN OPTOELECTRONICS.** \$5.00.



- ANTENNA PROJECTS.** \$5.00. Covers practical antenna designs including active, loop & ferrite types that are easy & inexpensive to build.
- RADIO STATIONS GUIDE.** \$4.75. Comprehensive listing of transmitters around the world. Presents location, frequency, power.
- LONG DISTANCE TV RECEPTION (TVDX) FOR THE ENTHUSIAST.** \$5.00. Practical & authoritative introduction to this unusual aspect of electronics.
- CB PROJECTS.** \$5.00. A number of useful and interesting designs for CB accessories. Speech processor, interference filter & more.
- CRYSTAL SET CONSTRUCTION.** \$4.50. Packed full of easy to duplicate designs for crystal radio receivers.
- AN INTRODUCTION TO RADIO DXING.** \$5.00. Listen, in your home, to broadcasts originating thousands of miles away. Tells how you can do it.

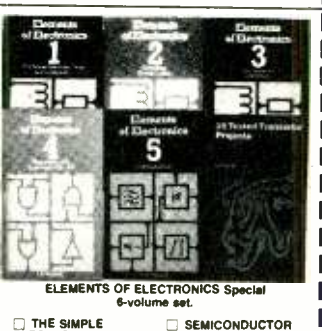

- THE SIMPLE ELECTRONIC CIRCUIT & COMPONENTS.** \$5.75. All the fundamental theory needed to lead to a full understanding of the simple electronic circuit and its components.
- ALTERNATING CURRENT THEORY.** \$5.75. Alternating current theory without which there can be no comprehension of speech, music, radio, or Television.
- MICROPROCESSING SYSTEM & CIRCUITS.** \$7.50. A truly comprehensive guide to all of the elements of a microprocessing system.
- SEMICONDUCTOR TECHNOLOGY.** \$5.75. Everything you always needed to know about solid-state devices in one volume.
- COMMUNICATIONS.** \$7.50. Covers most modern communication systems. Line, microwave, submarine, satellite, digital multiplex, radio & telegraphy.

**ELECTRONIC TECHNOLOGY TODAY INC.**  
P.O. Box 83, Massapequa Park, NY 11762

SP-7

Number of books ordered

Total Price of Books ..... \$ .....

Sales Tax (NY State Residents) .....

Shipping (75¢ 1st two books, 30¢ ea additional) .....

TOTAL ENCLOSED ..... \$ .....

Name .....

Address .....

City ..... State ..... ZIP .....

Prices good until July 31, 1983



*...you  
should  
see the  
rest!*

It's full of fun, sun,  
barefeet & bikinis.

It's runnin' with the wind  
to small, tropical islands  
and unique ports o' call for  
those with itchy feet and  
adventure in their soul.

We're not the Love Boat,  
but we'll take on anybody  
when it comes to beach-  
combing, sailing &  
exploring the exotic Carib-  
bean. It's our backyard  
and we know all the great  
places in paradise.

And, 6-day cruises start  
from \$425.

So send for the rest of the  
booklet. It's free!

Look us over & "sea it"  
our way!



**Windjammer**  
**Barefoot Cruises**, LTD.

Box 120, Dept. 1642, Miami Beach, FL 33119-0120

or call TOLL FREE and tell us you need the rest of the booklet: 800-327-2600 in FL: 800-432-3364

# The Workbench

(continued)



OK  
Industries  
Inc.



3456 Conner Street, Bronx, New York, 10475, U.S.A.  
Telex 1-55-1 OK NYK. Telex 232395 OK NY UR.  
Phone (212) 994-6600.

CIRCLE 802 ON FREE INFORMATION CARD