



*Air-Cooled*

**TRANSMITTING TUBES**

TECHNICAL MANUAL TT3

PRICE 35 CENTS

# This Manual Is Dedicated To You The User of Fine Radio Tubes

ONE of the earliest landmarks in "Wireless" was the RCA Tube and Equipment Manual released in November, 1921. Through the years, the name "RCA" has stood for leadership in promoting the progress of the Radio Art. The technical information contained in the following pages reflects continued advancement in engineering and manufacture.

In the design of transmitting tubes the RCA Laboratory has been governed by the principle that RCA Tubes must be capable of achieving optimum results in well-engineered circuits. The intensive application of this principle is exemplified by the advanced design, skillful manufacture, conservative ratings, uniform characteristics, and guaranteed performance of RCA Tubes.

Your acceptance of RCA Tubes means something more than an approval of the technical excellence of our product. It is an endorsement, we feel, of RCA service—built on the bulwark of permanence, reliability, and fair dealing.

RCA Tubes will save you money through uniformity, efficient operation, and long life. The air-cooled tubes described in this Manual are suitable for practically any transmitting application and are readily available through your RCA Power Tube Distributor.

*RCA Guarantees Its Products—  
Go RCA All the Way*

TUBE DEPARTMENT

**RADIO CORPORATION OF AMERICA**

# RCA TUBES

In addition to the Air-Cooled Transmitting Types  
described in this book  
the TUBE DEPARTMENT of  
RADIO CORPORATION OF AMERICA

supplies

WATER-COOLED TRANSMITTING TUBES  
CATHODE-RAY TUBES  
RECEIVING TUBES  
PHOTOTUBES  
THYRATRONS  
IGNITRONS  
GAS RECTIFIERS  
ETC.

For sales information on RCA Tubes, write to *Sales Division*,  
TUBE DEPARTMENT, RADIO CORPORATION OF AMERICA,  
Harrison, N. J.

For technical information on RCA Tubes, write to *Commercial  
Engineering*, TUBE DEPARTMENT, RADIO CORPORATION OF  
AMERICA, Harrison, N. J.

---

Copyright, 1938

by

RCA MANUFACTURING CO., Inc.

---

The sale of tubes described in this book carries a license under patent claims on the tubes themselves but only for (1) radio amateur uses, (2) radio experimental uses, (3) radio telephone broadcast reception, (4) one-way radio telephone broadcast transmission of entertainment or educational programs or police information, (5) electric phonograph uses, and (6) for use in connection with talking picture apparatus for the electrical reproduction of sound from records thereof, to be heard in the immediate vicinity of the reproducing apparatus.

The sale does not carry a license under patent claims on combinations of the tubes with other devices or elements, as for example in various circuits and book-ups, except only for legitimate renewals and repairs in apparatus and systems already licensed for use under such patent claims on combinations.

These tubes are licensed for no other use except by written contract of sale and/or lease between Radio Corporation of America or any of its subsidiaries and the purchaser and/or lessee.

Information contained in this book is furnished without assuming any obligations.

The license extended to the purchaser of tubes appears in the License Notice accompanying them. Information contained herein is furnished without assuming any obligations.

# CONTENTS

	PAGE
INTRODUCTION . . . . .	5
GENERAL VACUUM-TUBE CONSIDERATIONS . . . . .	6
Cathodes, Anodes, Grids, Bulbs, Bases	
GENERIC TUBE TYPES . . . . .	12
Diodes, Triodes, Tetrodes, Pentodes	
TRANSMITTING-TUBE INSTALLATION . . . . .	15
Filament and Heater Operation; Grid Voltage, Screen Voltage, and Suppressor Voltage Supply; Shielding; Precautions	
TRANSMITTING-TUBE APPLICATION . . . . .	19
Amplifier Definitions; Amplifiers—Class A, Class AB, Class B a-f and r-f, Class C; Frequency Multipliers; Crystal-Controlled Oscillators	
TECHNICAL DESCRIPTION BY TUBE TYPES . . . . .	32
Tabulated Data, Curves, Outline Drawings, Socket Connections	
TRANSMITTING-TUBE RATINGS . . . . .	141
Determination of Ratings, Considerations Influencing Ratings, Inter- pretation of Ratings, Effect of Frequency on Ratings	
TRANSMITTER DESIGN CONSIDERATIONS . . . . .	145
Choice of Tube Types, Grid-Bias Considerations, Inductance and Capacitance for Tuned Circuits, Interstage Coupling, Neutralization, Tuning an R-F Amplifier, Output Coupling, Parasitic Oscillations, Protective Devices	
USEFUL FORMULAS . . . . .	163
TRANSMITTING-TUBE CHARTS . . . . .	164
RECTIFIERS AND FILTERS . . . . .	170
CIRCUIT SECTION . . . . .	178
INDEX . . . . .	189
READING LIST . . . . .	192

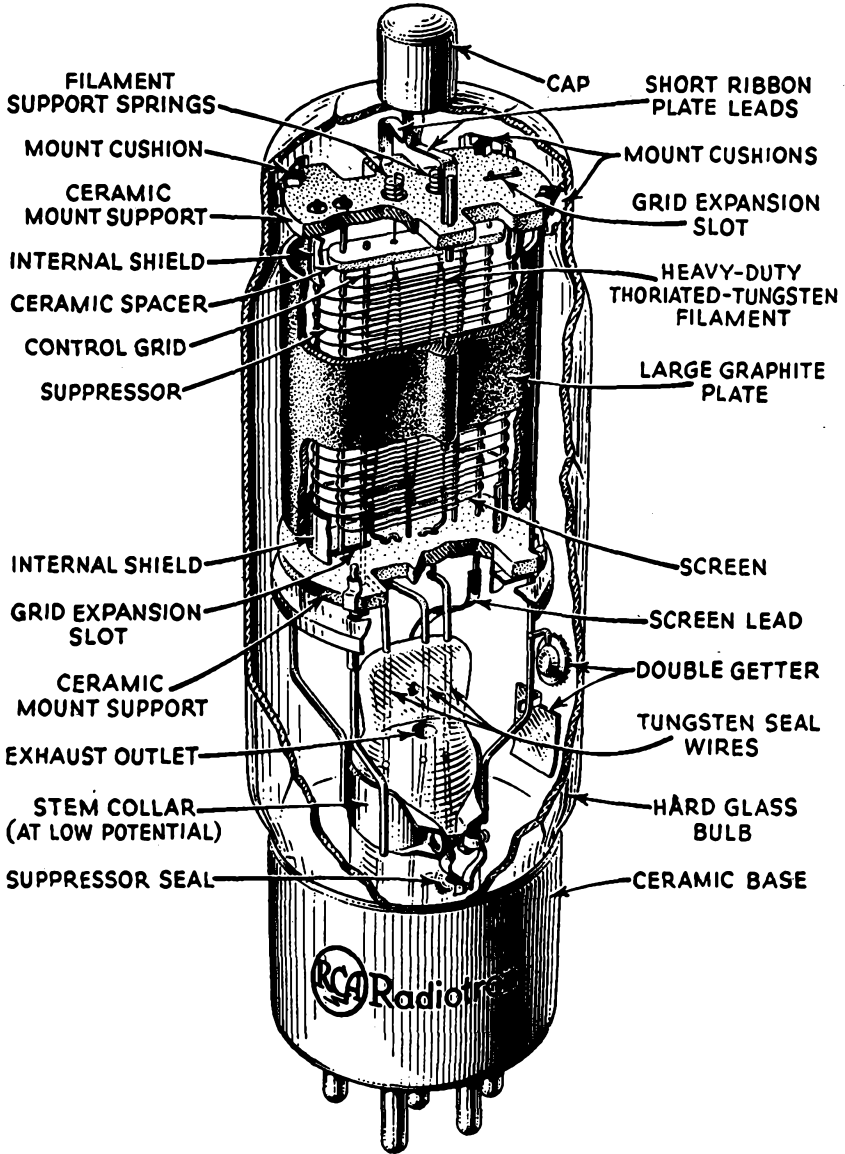

**STRUCTURE OF TRANSMITTING PENTODE RCA-803**



# TRANSMITTING TUBE MANUAL

## ON AIR-COOLED TUBES

**VACUUM TUBES!** The magic in these two words is best appreciated by the "old timers"—the amateur, commercial, and government operators who have followed the rapid progress of radio communication from its beginning. They remember those days not so long ago when spark transmitters, galena crystals, and loose-couplers exemplified the "state of the art." But the progress which had been made was to seem insignificant compared with the progress following the invention of the three-electrode vacuum tube by Dr. Lee DeForest.

The vacuum tube proved to be extraordinarily versatile. It could not only detect or amplify radio signals, but it could also be used as a generator of continuous-wave oscillations for transmitting purposes. Vacuum-tube transmitters consistently covered enormous distances with relatively little power. In addition, many stations could operate on the frequency channel previously occupied by a single spark transmitter. And then, as if these accomplishments were not enough, the vacuum tube made radio telephony feasible.

From this time on, radio progress was practically parallel to the development of larger, better transmitting tubes and more sensitive, more reliable receiving tubes. The very versatility of the vacuum tube necessitated the development of many different types, not only for different power requirements, but also for various applications.

The radio amateur and the professional radio engineer of today have an impressive array of tubes with which to design transmitting equipment. There are tube types for every application—master oscillators, frequency multipliers, buffer amplifiers, voltage amplifiers, power amplifiers, modulators, rectifiers, and many others.

Designed to meet the requirements of these diversified applications, RCA transmitting tubes are noted for their modern design, rugged construction, uniform characteristics, reliable performance, and long life.

# General Vacuum-Tube Considerations

A radio vacuum tube, whether designed for receiving or transmitting service, consists of a cathode and one or more additional electrodes—all contained in an evacuated enclosure—with their electrical connections brought out to external terminals. The evacuated enclosure may be made of glass, metal, or a combination of glass and metal. The cathode supplies electrons while the other electrodes control and collect them.

## CATHODES

A cathode is an essential part of a radio tube, because it supplies the electrons necessary for tube operation. In general, heat energy is applied to the cathode to cause it to release electrons. The method of heating the cathode may be used to identify different forms of cathodes. For example, a directly heated cathode, or **filament cathode**, is a wire heated by the passage of an electric current. An indirectly heated cathode, or **heater cathode**, consists of a filament (heater) enclosed by and insulated from a closely fitting metal sleeve (cathode) which is coated with electron-emitting material. The cathode is heated by radiation and conduction from the heater.

A filament, or directly heated cathode, can be further classified by identifying the filament or electron-emitting material. The materials in regular use are tungsten, thoriated tungsten, and metals which have been coated with alkaline-earth oxides.

A very important characteristic of any cathode is its electron-emitting ability for a given amount of heat energy. This characteristic, called **emission efficiency**, is the electron space current in amperes per watt of filament or heater power. For convenience, emission efficiency is usually expressed in milliamperes per watt.

### Tungsten Cathodes

Directly heated tungsten-filament cathodes are made from the pure metal. Because tungsten filaments must operate at a high temperature (a dazzling white) to emit electrons in useful quantity, tungsten requires a relatively large amount of filament-heating power; in other words, its emission efficiency is low. The large filament power dissipation requires a relatively large bulb for a fixed plate dissipation, or reduces the permissible plate dissipation for a bulb of fixed size.

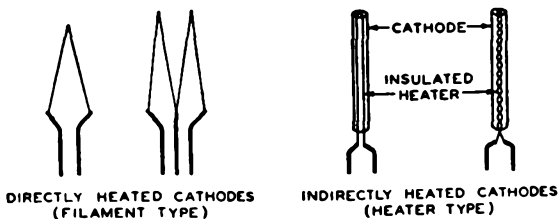

Advantages of tungsten as a cathode material are its ruggedness and its ability to withstand relatively heavy positive-ion bombardment in high-voltage tubes.

This bombardment, resulting from the presence of minute amounts of residual gas, is naturally more severe at higher plate voltages. Cathode materials which depend on a thin, active surface layer for their emission may quickly have this layer sputtered away by positive ions, with a resulting loss in emissivity. In the case of tungsten, the emission is an inherent property of the metal itself, so that there is no loss in emission even if some of the surface is sputtered away by positive-ion bombardment.

## Coated Cathodes

Coated cathodes are of two general types—the directly heated filament cathode and the indirectly heated cathode. The coated-filament type of cathode consists usually of a nickel-alloy wire or ribbon coated with a mixture containing certain alkaline earth oxides. This coating, consisting of a substantial layer on the filament wire, requires a very low temperature (a dull red) to produce a copious supply of electrons. Coated-filament cathodes, therefore, require relatively little heat energy and have a high emission efficiency—many times that of tungsten.

A heater cathode comprises an assembly of a thin metal sleeve, coated with an active material similar to that employed on coated-type filaments, and a heater element contained within and insulated from the sleeve. The heater is usually made of tungsten wire, or of a tungsten-molybdenum alloy, and is used solely for the purpose of heating the coated sleeve (actual cathode) to an electron-emitting temperature. The sleeve is heated by conduction and radiation from the heater. Due to the fact that the coated cathode is isolated electrically from the filament heating source, it is also called a **unipotential cathode**; unlike filament-type cathodes, it has no voltage drop along its length due to a heating current.

Advantages of the coated cathode are its high emission efficiency, relative freedom from filament or heater burn-out, low operating temperature, and its comparatively low hum level (especially in the unipotential-cathode type).

A disadvantage of the coated cathode is its tendency to contaminate adjacent electrodes with small quantities of active emitting material, so that emission from these electrodes may take place at relatively low temperatures. Despite their high emission efficiency, coated cathodes have been used in transmitting tubes principally in small, low-voltage types where operating temperatures of the electrodes are relatively low.

## Thoriated-Tungsten Cathodes

Thoriated-tungsten-filament cathodes are drawn from tungsten slugs which have been impregnated with thoria. In processing, a surface layer of thorium is formed; as a result, these cathodes liberate electrons at a medium temperature (a bright yellow). They have an emission efficiency between that of pure tungsten and coated cathodes.

Thoriated-tungsten filaments are suitable for use in tubes operating at a fairly high voltage. They are not used in tubes operating at extremely high voltages because the surface layer of thorium may be sputtered off by positive-ion bombardment; this results in loss of emission. Thoriated-tungsten filaments are substantially free from grid-emission effects and possess the unique capability of being reactivated (in many cases) after their emission has been lost because of temporary



tube overloads. Information regarding the reactivation of thoriated-tungsten filaments is given under TRANSMITTING-TUBE INSTALLATION.

The choice of cathode material for a transmitting tube depends upon the service for which the tube is designed. The plate voltage to be used on the tube is an important factor, as is also the cathode emission required. In general, coated cathodes have been employed in small, low-voltage tubes; thoriated-tungsten filaments have been used in medium-power tubes operating at fairly high voltages; and tungsten filaments have been used in large, high-power tubes operating at very high voltages. However, design requirements control the choice of cathode material for specific RCA tube types.

## ANODES

For any tube there is a maximum amount of power that can be dissipated safely by the anode, or plate, if reasonable tube life is to be obtained. The safe anode dissipation of a transmitting tube is one of the most important factors controlling the amount of power the tube will deliver. Anodes can be classified according to the principal method of cooling employed. In some types of tubes the anodes are cooled almost entirely by radiation; in others, by conduction. Only the first type will be considered here.

In a radiation-cooled tube, the anode is operated at a fairly high temperature and heat is radiated directly by the anode to and through the walls of the bulb (generally of glass). It is usually necessary to operate such anodes at fairly high temperatures in order to keep their physical dimensions commensurate with the desired electrical characteristics of the tubes.

Operation of anodes at such high temperatures brings up numerous problems. The liberation of gases from the anode itself is one of the most important. In the raw state, all materials suitable for anodes contain gases—mainly hydrogen, nitrogen, carbon monoxide, and carbon dioxide—which are present throughout the body of the material. The major portion of these gases must be driven out of the anode during the manufacture of a tube so that in subsequent normal operation no appreciable quantities of gas are liberated. The assembled tube is sealed to a vacuum system where the glass bulb can be "baked" to free it of adsorbed gases. The anodes are heated in two ways. One method is to supply a high positive voltage to the anode and bombard it with electrons from the cathode. Another method is to place around the glass bulb a coil carrying high-frequency currents. The anode then acts as a short-circuited secondary of a transformer and is heated to a high temperature by induced currents.

Some of the most important considerations in the choice of an anode material for radiation-cooled tubes are its thermal emissivity, its mechanical properties, and its vapor pressure.

The thermal emissivity should approach as nearly as possible the ideal of a black body, in order to obtain the highest dissipation rating for a given anode design and anode operating temperature (the temperature being determined by gas liberation). At first thought it might appear that the size of the anode could be increased to get the desired dissipation rating for an anode of a given material. However, this usually results in an increase in the electrostatic capacitance between the anode and the other tube electrodes; it also increases the weight of the anode which means heavier mounting supports and a larger mass of material from which gases must be removed. Because of the pronounced trend to higher frequencies in radio communication, it is important to keep interelectrode capacitances to a minimum so that capacitance charging currents, which entail losses, can be limited to reasonable values.

The mechanical properties of an anode material are very important. The material must be capable of being worked readily into the desired shapes and must maintain these shapes at the high temperatures employed during tube manufacture. Only a very small amount of warping can be tolerated at the normal operating

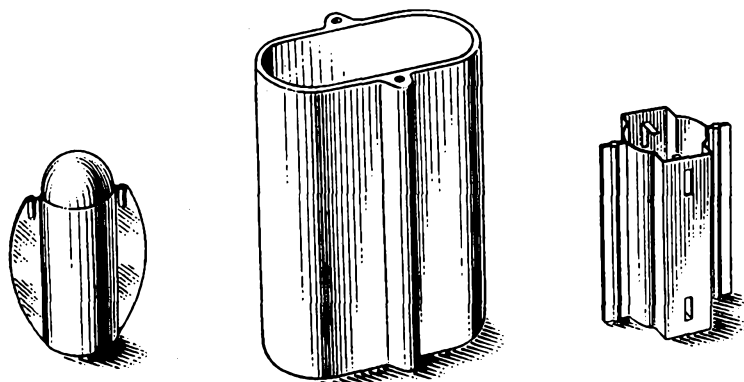

Typical Anode Structures

temperature, because warping may produce a change in the electrical characteristics of a tube.

The vapor pressure of an anode material must be low enough so as not to cause appreciable metallic deposits in a tube during manufacture. Such deposits on the insulators in a tube may result in excessive interelectrode leakage or in excessive radio-frequency losses in the insulators.

Various materials have been used for transmitting-tube anodes. A brief description of the materials which have been most widely used is given in the following paragraphs.

### Tungsten

Tungsten was one of the first materials employed for anodes in air-cooled tubes. From the standpoint of gas content, ease of degassing, vapor pressure, and maintenance of mechanical shape at high temperatures, tungsten is a satisfactory material for anodes. However, from the standpoint of workability, tungsten has a serious disadvantage. It is difficult to fabricate into the desired shapes and is, therefore, little used at present as an anode material.

### Molybdenum

The characteristics of the metal molybdenum make it suitable for use as an anode material. Although its thermal emissivity is rather low, molybdenum degases readily and is much more workable than tungsten. The heat-dissipating ability of molybdenum anodes is improved by the addition of fins (e.g., such as in type 852), which increase the radiating area of the anode. Further improvement is obtained when the anode surface is roughened by means of carborundum blasting.

### Graphite

Graphite is used as an anode material in many radiation-cooled tube types. Although graphite contains considerably more adsorbed gases than either tungsten or molybdenum, these gases can be largely removed by suitable manufacturing technique. This includes pretreatment of graphite anodes before the tubes are assembled.

The thermal emissivity of graphite depends on the treatment the surface has received. Compared with molybdenum anodes, graphite anodes operate at a visibly lower temperature for the same power dissipation. Some users of transmitting tubes find it convenient to judge the operating efficiency of a tube by observing

the color temperature of the anode. With tungsten, molybdenum, and tantalum anodes this is easily possible, because at the normal operating temperature the anodes are distinctly cherry- or orange-red in color. With graphite, however, practically no color can be seen in normal operation so that it is very difficult to judge visually how much energy is being dissipated by the anode.

Graphite anodes are made with relatively thick walls for mechanical strength. They are not subject to warping and have the further advantage that their good heat conductivity, due to the thick walls, prevents "hot spots." The absence of hot spots means that the graphite anode radiates heat almost uniformly over its entire surface. Because graphite, as ordinarily termed, is a complex mixture of a variety of carbon forms, some of which produce undesirable effects in anodes, careful selection and processing of graphite anode material is essential.

Mechanically, graphite presents no serious problems. It is a soft material and, therefore, can readily be formed into the desired shapes. The vapor pressure of graphite is low enough so that bulb blackening can be avoided during the exhausting of a tube.

## Nickel

Because of the relatively low melting point of nickel, this anode material is used principally in tubes where the anode operating temperature is moderate. Although the thermal emissivity of nickel is not high, this material lends itself readily to a process called carbonizing. In this process, a well-adhering layer of amorphous carbon is deposited on the nickel anode to provide a thermal emissivity approaching that of a black body. Nickel is formed readily into the shapes desired for anodes. Care must be exercised in the design of the anode to avoid warping during exhaust. Like other metal anode materials, nickel has the advantage of light weight, so that elaborate supporting structures are not needed.

## Tantalum

A metal which is finding increasing use as an anode material is tantalum. Although the properties of this material have been known for many years, it has been used commercially in transmitting tubes for a relatively short time. The appearance and many of the characteristics of tantalum are similar to those of molybdenum. Tantalum has the same metallic luster, a slightly higher melting point, a lower vapor pressure, and is more easily worked into various mechanical shapes. The principal advantage of tantalum is that it will clean up gases and, thus, is capable of helping to maintain a high vacuum in a tube during normal operation. Sudden tube overloads of short duration do not cause tantalum anodes to liberate appreciable gas.

Tantalum anodes are usually made with fins and with a rough surface to increase the effective heat-radiating area. Under conditions of maximum rated plate dissipation, tantalum anodes will show a red to orange-red color. They will normally show some color even when the tubes are lightly loaded. The color characteristic of tantalum anodes serves as a rough indication of the power being dissipated.

RCA tubes such as the 808, 833, and 861 are examples of tantalum-anode construction.

## GRIDS

The metals and alloys suitable for anode material are, in general, also useful for grid structures. Like anode materials, a good grid material should have reasonably low gas content, should be easy to degas, and should have sufficient mechanical

strength to hold its shape while operating at very high temperatures. A very small change in the shape of a control-grid structure results in a relatively large change in tube characteristics. Grid material should be suited for drawing into wire, because grids are often formed of spirally wound wire supported by metal side rods.

An important consideration in the choice of grid material is the electron-emitting characteristic of the material, especially in the presence of other elements which may be used in tube manufacture. In most types of r-f service the grid is driven positive part of the time, so that the grid is bombarded by electrons and must dissipate some power. If the grid material is active enough, or the grid temperature gets high enough, primary grid emission may take place. This effect should be minimized in tube operation because it may result in loss of grid bias if a grid leak is employed. Grid structures are sometimes pretreated in various manners to reduce primary grid emission.

When the control grid is driven positive, the primary electrons which bombard it may dislodge secondary electrons. This effect, called **secondary emission**, may also cause a loss of grid bias, and must be minimized by proper choice of grid materials and by suitable processing methods.

Some of the metals used for grids are tungsten, molybdenum, tantalum, and also nickel alloys, such as magno-nickel. The latter is an alloy of nickel and manganese. Alloys of molybdenum and tungsten are also employed. Grid materials in some cases are coated with carbon to reduce secondary-emission effects and to increase thermal emissivity.

## BULBS

The kind of glass used in the manufacture of bulbs for transmitting tubes must meet specific requirements. It must have good mechanical strength, be a good electrical insulator, stand high temperatures, and should be easily freed of adsorbed gases.

Where heat-dissipation requirements are moderate and where bulb size is not especially important, so-called "soft" glass is a suitable material. If the bulb size must be kept small, "hard" glass is employed. The important physical distinction between soft glass and hard glass is that the latter has an appreciably higher softening point (about 750°C compared to 625°C). Hard glass is generally employed for the larger air-cooled tube types, where bulb size is an important factor.

## BASES

Base materials are of two general types—ceramic and plastic. Ceramics include glass (usually Pyrex) and various silicates, of which porcelain is an example. The plastic material in common use is Bakelite. Some tube bases are composed of metal shells with an insulating bottom disc.

The better grades of ceramic insulators cause less radio-frequency losses at high frequencies than most plastics suitable for use in bases. However, the use of ceramic bases is generally limited to tubes where fairly high r-f voltages appear between some of the base pins.

A basic principle guiding the manufacture of RCA transmitting tubes is the use of those materials which provide a well-balanced tube design. The true measure of radio-tube value is optimum performance with minimum cost. In choosing proper materials to accomplish this result, RCA has the benefit of long manufacturing experience supplemented by intensive research and comprehensive operating experience.

# Generic Tube Types

## DIODES



The simplest form of radio vacuum tube is the two-electrode type consisting of a cathode and an anode, or plate. This type, called a **diode**, is used in transmitting service mainly as a rectifier to convert low-frequency a-c voltages from the power line to d-c voltages for plate, screen, and grid-bias supplies. Simple diodes, such as the 866, are called **half-wave rectifiers** because they rectify but one-half of each alternating voltage cycle. When two diodes are enclosed in a single envelope, the tube is called a **full-wave rectifier** because it rectifies both halves of each a-c cycle. The receiving types 5Z3 and 83 (described in the RCA Receiving-Tube Manual) are typical examples.

Both half- and full-wave rectifiers are of two general types—high-vacuum and mercury-vapor. The latter type, represented by the 866 and the 83, is characterized by a very low and approximately constant internal voltage drop, amounting to about 15 volts. This drop is practically independent of d-c load current, but depends to some extent upon the temperature of the mercury vapor within the bulb. Mercury-vapor rectifiers, in operation, have a characteristic bluish glow which fills a considerable portion of the bulb. The extent of the glow depends on the value of the d-c load current.

Due to their low and relatively constant internal voltage drop, mercury-vapor rectifiers are very useful in applications where excellent voltage regulation of the d-c power supply is desired. Class B modulators represent one such application.

High-vacuum rectifiers have an internal voltage drop which is proportional to the d-c load current being drawn. With varying d-c load currents they do not, in general, provide the good voltage regulation obtained from mercury-vapor rectifiers. Some high-vacuum rectifiers, such as the 836, are designed with close-spaced electrodes, so that a voltage regulation almost as good as that of a mercury-vapor type is obtained.

Additional information on rectifiers is given under **RECTIFIERS AND FILTERS**.

## TRIODES

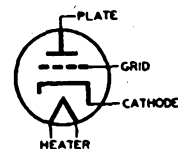

When a third electrode, called the **control grid**, or simply **grid**, is placed between the cathode and the plate, the tube is known as a **triode**. The grid usually consists of a wire mesh, spiral, or grating, the appearance of which suggests its name.

When the grid of a triode is made positive or negative with respect to the cathode, the plate current correspondingly increases or decreases. This action makes possible the use of a triode as an amplifier. The electrical impulse to be amplified, is applied to the grid of the tube and thus controls electrostatically the flow of electrons from the cathode to the plate. The energy required to draw the electrons

to the plate comes from a high-voltage d-c supply in the plate circuit. The power required to vary the electron stream from the cathode to the plate ordinarily is only a fraction of the power flowing in the plate circuit. Therefore, the action of the tube is that of a valve, the d-c power of the high-voltage plate supply being converted by the grid-voltage variations into a-c power in the plate load circuit. The efficiency of this energy conversion is never 100 per cent, and some power is dissipated by the plate of the tube.

Triodes are used in transmitters as oscillators, frequency multipliers, r-f power amplifiers, a-f amplifiers, modulators, and for various special purposes. Some types are especially designed for audio power-amplifier service, but most types can be used in either r-f or a-f applications.

The grid, plate, and cathode of a triode form an electrostatic system, each electrode acting as one plate of a small condenser. The capacitances are those existing between the grid and plate, plate and cathode, and grid and cathode. These capacitances, as well as those of tubes having additional electrodes, are known as **interelectrode capacitances**. Generally, the grid-plate capacitance is the most important. In radio-frequency amplifier circuits, this capacitance may act to produce undesired coupling between the input and output circuits and cause uncontrolled regeneration or oscillation.

## TETRODES AND PENTODES

The effect of grid-plate capacitance in causing excess regeneration can be eliminated in a number of ways. One scheme requires the use of special circuit arrangements which set up counteracting effects to balance out the action of the grid-plate coupling. This method is known as **neutralization**. A second and preferable method is to reduce the grid-plate capacitance in the tube itself to a negligible value. This is accomplished by employing a fourth electrode in the tube which is known as the **screen**. The screen is placed between the plate and the grid and thus makes a four-electrode tube—hence the name tetrode. With this type of tube, intricate circuits and balancing difficulties can be eliminated.

The screen is constructed so that the flow of electrons to the plate is not materially obstructed, yet it serves to establish an electrostatic shield between the plate and the grid. The screen is usually operated at some positive voltage lower than that of the plate and is by-passed to the cathode through a condenser having low impedance at the operating frequency. This by-pass condenser effectively grounds the screen for high-frequency currents and assists in reducing the effective grid-plate capacitance to a minimum value. This reduction permits tetrodes to provide a high order of stable amplification with relatively simple circuits. The 865 and 860 are representative tetrodes.

In all radio tubes, electrons striking a positive electrode may, if moving at sufficient speed, dislodge or "splash out" other or secondary electrons. In diodes and triodes, such secondary electrons produced at the plate usually do not cause any trouble because no positive electrode other than the plate itself is present to attract them. These electrons, therefore, are eventually drawn back to the plate.

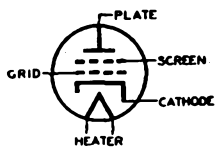

In tetrodes, the screen (operating at a positive potential) offers a strong attraction to secondary electrons when the plate voltage swings lower than the screen voltage. This effect limits the permissible plate swing for tetrodes because the major portion of the space current then goes to the screen rather than to the plate. The plate-swing limitation can be substantially removed when a fifth electrode, known as the **suppressor**, is placed in the tube between the screen and the plate. Such five-electrode types are called pentodes.

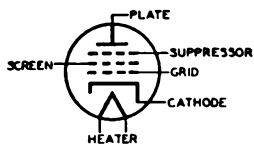

The suppressor in a pentode is usually connected to the cathode, or to a low positive or negative voltage, depending on the tube application. Because of its negative potential (in any case) with respect to the plate, the suppressor retards the flight of secondary electrons and diverts them back to the plate, where they cause no undesirable effects. Thus, in pentodes, the plate voltage may swing below the screen voltage.

In a beam power tube (e.g., type 807), the function of the suppressor grid is performed by a potential minimum which exists between the screen and the plate, suppresses secondary emission from the plate, and which gives the tube pentode characteristics.

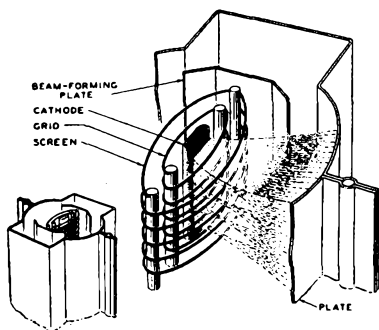

Internal Structure of an RCA Beam Power Tube

In general, pentodes and beam tetrodes have high **power sensitivity**. This means that very little driving power is required in comparison with the power output obtained. For this reason, such tubes are especially useful in multi-stage transmitters as buffer amplifiers and frequency multipliers. The use of pentodes and beam tetrodes reduces the total number of stages required to obtain a specific

power gain. These tubes also find useful application in certain types of oscillator circuits.

A pentode in radio-telephony service can be modulated by means of the suppressor. Under proper operating conditions, modulation of almost 100 per cent can be obtained with good linearity. Because the suppressor is usually operated at a negative potential over most of the a-f cycle, very little modulating power is required. A typical circuit illustrating suppressor modulation is shown in the **CIRCUIT SECTION**.

# Transmitting-Tube Installation

Information regarding the required type of socket or mounting is given in the data under each individual tube type. In most cases, the socket is mounted to hold the tube in a vertical position with the base down, although some tubes may be operated in a horizontal position. Exceptions are described under the respective tube types. Where the tube is subjected to vibration or shock, a shock-absorbing suspension should be employed.

The bulb becomes very hot during continuous operation of a tube; therefore, free circulation of air around the tube should be provided. Care should be taken that the bulb does not come in contact with any metallic object nor be subjected to the spray of any liquid. The installation of all wires and connections should be made so that they will not be close to or touch the bulb, in order to avoid possible puncture of the glass due to peak voltage effects. In the case of tubes with metal cap terminals, such as the 806, 808, and 866, flexible leads should be used to make connections to these terminals in order to minimize strains placed on the glass bulb at the base of the caps. It is important that the caps should not be used to support coils, condensers, chokes, or other circuit parts. Under no circumstances should anything be soldered to the caps, because the heat of the soldering may crack the bulb seals. The flexible leads should be big enough to carry, without noticeable heating, the large circulating r-f currents which flow in the circuits at high frequencies.

The cathodes used in RCA transmitting tubes are of several types, as described in GENERAL VACUUM-TUBE CONSIDERATIONS. Filament-type cathodes include thoriated-tungsten filaments and oxide-coated filaments. Indirectly heated oxide-coated cathodes are employed in some tube types.

**Thoriated-tungsten filaments**, in general, may be operated from either an a-c or a d-c source. Except where a d-c source is necessary to avoid hum, an a-c filament supply is generally used because of its convenience and economy. Where d-c is used for the filament supply, the grid and plate returns should be made to the negative filament terminal rather than (as in the case of an a-c filament supply) to the mid-tap of the filament circuit. For the larger tube types, a suitable voltmeter should be connected permanently across the tube filament terminals to provide a ready check of the filament voltage. This voltage should not vary more than plus or minus 5% from the rated value; otherwise, a loss of filament emission may result. When the apparatus in which the tube is used is idle for short periods of time, the filament should be maintained at its rated voltage during the "stand-bys." When an a-c filament supply is used, rheostat control is placed preferably in the primary circuit of the filament transformer.

Overheating, by severe overload, of tubes employing thoriated-tungsten filaments may decrease filament emission. The activity of the filament can sometimes be restored by operating the filament at rated voltage for ten minutes or more with no voltages applied to the other electrodes. This process may be accelerated by raising the filament voltage a small amount above its rated value for a few minutes. The maximum voltage which should be used is 9 volts for 7.5-volt types, 12 volts for 10-volt types, and 13 volts for 11-volt types.



**Oxide-coated filaments** may be operated from either an a-c or a d-c source. An a-c filament supply is generally used because of its convenience and economy. When d-c is employed, the grid and plate returns should be made to the negative filament terminal, rather than to the electrical center of the filament circuit as in the case of a-c filament operation. The voltage across the filament terminals should be checked periodically and should be maintained within plus or minus 5% of the rated value. An oxide-coated filament should be allowed to come up to normal operating temperature before voltage is applied to the plate; otherwise, a loss of filament emission may result. In radio transmitters during "standby" periods, the filament should be kept at its rated voltage to avoid a delay in the resumption of transmission. Data relating to the filament operation of specific tube types (especially rectifiers) are given in the text following the tabulated data on those types.

The heaters of those tubes employing indirectly heated cathodes may be operated from either an a-c or a d-c supply. A.c. is usually employed because of its convenience and economy. The voltage across the heater terminals at the socket should be checked periodically. In radio transmitters, during "standby" periods, the heater should be maintained at its rated voltage in order that transmissions can be promptly resumed.

The cathode should be connected to the electrical mid-point of the heater circuit when the heater is operated from an a-c source. Where cathode bias is used, the cathode should be connected to the same point through the cathode-bias resistor. When the heater is operated from a d-c source, the cathode circuit may be connected to either heater-supply lead. In circuits where the cathode is not tied directly to the heater, the potential difference between them should be kept as low as possible. Recommended values for heater-cathode potential differences are given in the data under the tube types. Where a large resistance is necessary between heater and cathode in some circuit designs, the resistor should be bypassed for both r-f and a-f frequencies, to avoid the possibility of hum and circuit losses.

The plate dissipation (*the difference between plate input and power output*) should never exceed the maximum values given under **MAXIMUM RATINGS** and **TYPICAL OPERATING CONDITIONS**. Information as to the operating color, or lack of color, of the plate for maximum plate dissipation is included in the data under each type tube.

A d-c milliammeter should always be used in the plate circuit to provide a continuous check of plate current. Under no condition should the d-c plate current exceed the maximum values given under **MAXIMUM RATINGS** and **TYPICAL OPERATING CONDITIONS**. A d-c meter placed in the grid-return circuit is an invaluable aid in checking r-f grid excitation as well as in making tuning and neutralizing adjustments. If a d-c milliammeter is placed in the filament-to-ground return lead, or in the negative high-voltage supply lead, the meter should be shunted by a suitable resistor having about 100 times the resistance of the meter. This arrangement will prevent the r-f amplifier stage or the framework of the rectifier from assuming a high d-c potential with respect to ground in the event that the meter should develop an open circuit from any cause. With a ratio of external resistance to meter resistance of 100, the effect of the external resistor on the meter reading is very small—about one per cent.

The **control-grid bias voltage** can be obtained by any one of three general methods, or by a combination of these methods, depending on the class of service in which the tube is used. The three methods for obtaining grid bias are: (1) from a fixed-voltage supply, such as a battery, or a rectifier having good regulation; (2) from a grid-leak resistor; and (3) from a cathode resistor (self-bias). Some types of bias supply are not suitable for some classes of tube operation. The recommended types of bias supply for each class of service are given under TRANSMITTING-TUBE APPLICATION. For additional information on biasing methods, refer to TRANSMITTER DESIGN CONSIDERATIONS.

The **screen voltage** for pentodes and tetrodes may be obtained from a separate source, from a potentiometer, or from the plate supply through a series resistor. The method employed depends on the service in which the tube is used (see TRANSMITTING-TUBE APPLICATION) and on the tube type. Where the series-screen-resistor method is used, the resistor should have a value sufficient, under load conditions, to drop the high voltage to a d-c value which is within the maximum screen-voltage rating given under each tube type. In general, when the key is up in telegraph service and when modulation is applied in plate-modulated service, it is permissible for the peak screen voltage to rise to twice the maximum d-c value shown in the tabulated data under the tube type. In those cases where series-screen-resistor values are shown in the tabulated data for class C telegraphy service, the peak screen voltage is permitted to rise to the full d-c plate-voltage value under key-up conditions. Suitable values of screen resistors are shown in the tabulations. In those classes of service where screen-voltage regulation is not an important factor, the series-resistor method of obtaining screen voltage is desirable, because of its simplicity and because it serves to limit the d-c power input to the screen. With this method, however, it is important that the high-voltage supply switch be opened before the filament, heater, or cathode circuit is opened and before the r-f excitation is removed; otherwise, the screen voltage will rise to an excessive value. When the screen voltage is obtained from a separate source, or from a potentiometer, plate voltage should be applied before the screen voltage, or simultaneously with it; otherwise, with voltage on the screen only, the screen current may be large enough to cause excessive screen dissipation. A d-c milliammeter should be used in the screen circuit in most cases, so that the screen current and the d-c power input to the screen can be determined. The screen power input should never be allowed to exceed the maximum rated value shown in the tabulations.

**Suppressor voltage** for pentodes may be obtained from any fixed-voltage d-c supply. In cases where the suppressor draws current, the supply should be a battery or other source having good voltage regulation.

The use of a **protective device** in each transmitting-tube circuit is usually advisable to safeguard the tube against accidental overloads. This device preferably should remove the d-c plate voltage when the d-c plate current reaches a value about 50 per cent greater than normal. For small, low-power tubes, a high-voltage fuse placed in series with the positive plate-voltage lead is usually satisfactory. For the larger transmitting tubes, an instantaneous d-c overload relay should be employed. In r-f amplifier stages employing low- or medium- $\mu$  tubes with grid-leak bias, it is especially important that a protective device be used to safeguard the tube against a heavy d-c plate-current overload in case the r-f grid excitation should fail. Such failure, with grid-leak-biased tubes, results in a total loss of the d-c grid bias. Additional information on protective devices is given in TRANSMITTER DESIGN CONSIDERATIONS.

Adequate **shielding** and isolation of the input circuit and the output circuit of pentodes and tetrodes are necessary if optimum results are to be obtained. The impedance between the screen and filament (or cathode) must be kept low, usually by means of a suitable by-pass condenser. When the screen voltage is obtained

from the plate supply through a series resistor, the screen by-pass condenser should have a voltage rating at least equal to the d-c plate voltage applied to the tube. The capacitance value of the condenser may be in the order of 0.01 to 0.1  $\mu$ f. In telephony service where the screen voltage is modulated, a smaller capacitance may have to be used in order to avoid excessive a-f by-passing. If the screen by-pass condenser is made too small in value, however, r-f feedback from plate to control grid may result, depending on the circuit layout, operating frequency, and power gain of the stage. A-f by-passing difficulties can be largely eliminated if the screen by-pass condenser is replaced by a series-tuned circuit resonant at the operating frequency. The series-tuned circuit presents a high impedance to audio frequencies, but a very low impedance to its resonant frequency.

Heavy leads and conductors together with suitable insulation should be used in all parts of the r-f plate tank circuit so that losses due to r-f voltages and currents can be kept at a minimum. Because proper circuit design becomes very important at the higher frequencies, it is essential that short, heavy leads and circuit returns be used in order to minimize lead inductance and losses.

In order that the maximum ratings given under MAXIMUM RATINGS and TYPICAL OPERATING CONDITIONS will not be exceeded, changes in electrode voltages due to line-voltage fluctuation, load variation, and manufacturing variation of the associated apparatus should be determined. An average value of voltage for each electrode should then be chosen so that under the usual voltage variations the maximum rated voltages will not be exceeded.

*When a new circuit is tried or when adjustments are made, the plate voltage should be reduced in order to prevent damage to the tube or associated apparatus in case the circuit adjustments are incorrect. It is advisable to use a protective resistance in series with the high-voltage plate lead during such adjustments. The value of this resistance can be obtained with sufficient accuracy by taking one-half of the tube's plate resistance, as determined by Ohm's law from the typical operating conditions to be used. For example, a single 834 operating with a d-c plate voltage of 1000 volts and a d-c plate current of 100 milliamperes represents a resistive load of 10000 ohms (1000/0.1). The protective resistance should be about 5000 ohms, the exact value not being critical. Suitable meters should be provided for measuring tube voltages and currents as well as for making transmitter adjustments. When modulation is employed, a cathode-ray oscillograph also is recommended to assist in the making of final adjustments for optimum performance. Under no conditions should the maximum values given under MAXIMUM RATINGS and TYPICAL OPERATING CONDITIONS be exceeded.*

*The rated plate voltage of practically all transmitting tubes is high enough to be dangerous to the user. Great care should be taken during the adjustment of circuits, especially those in which the exposed circuit parts are at a high d-c potential. In the design of apparatus, precautions should include the enclosing of all high-potential circuit elements and the use of "interlock" switches to open the primary circuit of the high-voltage power supply when access to the apparatus is required.*

# Transmitting-Tube Application

Radio tubes are used in transmitters in a number of different ways, depending on the results to be achieved. Four distinct classes of amplifier service recognized by engineers are covered by definitions standardized by the Institute of Radio Engineers. This classification depends primarily on the fraction of input cycle during which plate current is expected to flow under rated full-load conditions. The four principal modes of operation are identified as class A, class AB, class B, and class C.

A class A amplifier is an amplifier in which the grid bias and alternating grid voltages are such that plate current in a specific tube flows at all times.

A class AB amplifier is an amplifier in which the grid bias and alternating grid voltages are such that plate current in a specific tube flows for appreciably more than half but less than the entire electrical cycle.

A class B amplifier is an amplifier in which the grid bias is approximately equal to the cut-off value so that the plate current is approximately zero when no exciting grid voltage is applied, and so that plate current in a specific tube flows approximately one-half of each cycle when an alternating grid voltage is applied.

A class C amplifier is an amplifier in which the grid bias is appreciably greater than the cut-off value so that the plate current in each tube is zero when no alternating grid voltage is applied, and so that plate current flows in a specific tube for appreciably less than one-half of each cycle when an alternating grid voltage is applied.

To denote that grid current does not flow during any part of the input cycle, the suffix 1 may be added to the letter or letters of the class identification. The suffix 2 may be used to denote that grid current flows during some part of the cycle.

For radio-frequency amplifier tubes which operate into selective tuned circuits, as in radio transmitter applications, or under requirements where distortion is not an important factor, any class of amplification may be used, in either a single-ended or a push-pull stage. For audio-frequency amplifiers in which distortion is an important factor, only class A amplifiers permit single-tube operation. For class AB or class B audio service, a balanced amplifier stage using at least two tubes is required.

## CLASS A AUDIO AMPLIFIERS

An ideal class A amplifier is one in which the output wave shape is an exact reproduction of the input wave shape. In a practical class A amplifier, the grid is usually not driven positive (with respect to the cathode) by the input signal

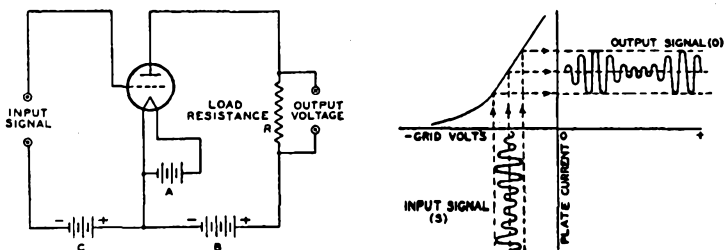

Fig. 1

and is never driven negative so far that plate current is cut off. The average d-c plate current is substantially constant between the conditions of no signal and full signal. The plate efficiency, or ratio of a-c power output to average d-c power input, is relatively low for triodes—about 20 to 30 per cent at full output, depending on the design of the tube and on the operating conditions. Fig. 1 illustrates class A amplifier operation.

Specially designed tubes of the triode type are frequently used as class A audio-frequency power amplifiers to modulate radio-frequency carriers. These tubes, which are usually driven by class A voltage amplifiers, require a relatively large input signal even though practically no power is required by the grid circuit. Class A audio power tubes, such as the 845 and 849, are generally characterized by a low or medium amplification factor.

Grid bias for class A service may be obtained from a separate d-c voltage source or by means of a cathode-bias resistor shunted by a condenser. This condenser should be large enough to minimize degenerative effects at low audio frequencies. When the cathode-resistor method of bias is used, the proper value of the cathode resistor can be determined by the equation  $R = 1000 E/I$ , where R is the cathode-bias resistance in ohms, E is the rated d-c grid-bias voltage, and I is the cathode current in milliamperes. For a triode, the cathode current is simply the plate current; for tetrodes and pentodes, it is the sum of plate and screen currents.

If more audio power output is desired than can be obtained from a single tube, two or more tubes can be operated in parallel or in push-pull. The parallel connection provides twice the output of a single tube with the same input-signal voltage. The push-pull connection requires twice the input-signal voltage, but has, in addition to the increase in power, a number of important advantages over single-tube operation. Distortion due to even-order harmonics and hum due to plate-supply ripple voltages are either eliminated or decidedly reduced through cancellation in the output circuit. Because harmonic distortion is reduced, appreciably more than twice single-tube output can be obtained by using a plate-to-plate load resistance only slightly larger than the value for single-tube operation.

If the bias for two tubes in push-pull is supplied by a single cathode resistor, a large by-pass condenser should be used across the resistor to minimize distortion. With either the parallel or the push-pull circuit, the d-c grid bias is the same as for a single tube. Where a number of tubes are operated in parallel or in push-pull, it may be necessary to provide individual adjustment of grid bias to insure that the plate dissipation of each tube does not exceed the maximum rated value. This can be accomplished by means of a tapped C-supply, or by means of a variable cathode-bias resistor for each tube. A separate filament-supply winding and a separate cathode-resistor by-pass condenser are necessary for each tube that is individually biased with a cathode resistor. Where tubes are operated in parallel, a non-inductive resistance of 10 to 100 ohms should be placed in series with each grid lead, at the tube socket, to prevent parasitic oscillations.

Where the input circuit of an a-f power amplifier is resistance- or impedance-coupled to the preceding stage, the resistance in series with the grid circuit should not be made too high. The permissible grid-circuit resistance is usually larger for tubes that are self-biased than for tubes that have a fixed-bias supply, due to the protective action of the cathode-bias resistor. The recommended maximum value of grid-circuit resistance is given in the tabulated tube data.

Operation of audio power amplifiers so that the grids are driven positive on any portion of the input-signal cycle is inadvisable except under conditions discussed in the sections on class AB and class B amplifiers. A circuit of a typical push-pull class A amplifier (using two 6C5's) is shown in the CIRCUIT SECTION.

The power output of triodes as class A amplifiers can be calculated graphically without serious error from the plate family curves. The proper plate current, grid bias, and optimum load resistance, as well as the per cent second-harmonic

distortion, can also be determined. The method of calculation is not within the scope of this book; however, information on this subject can be obtained from references No. 4, No. 18, and No. 21 in the READING LIST.

## CLASS AB AUDIO AMPLIFIERS

A class AB audio power amplifier consists of a push-pull stage in which the tubes are operated with a negative grid bias larger than that used for class A operation. With this larger grid bias, the plate (and screen) voltage can usually be made higher than the value used for class A operation because the increased negative bias reduces the d-c plate current at zero signal to a value such that the plate-dissipation rating of the tube is not exceeded. A class AB amplifier will deliver more power output than a class A amplifier because of the higher voltages employed and because of its higher efficiency.

Class AB amplifiers are divided into two groups—class AB<sub>1</sub> and class AB<sub>2</sub>. In a class AB<sub>1</sub> amplifier there is no flow of grid current because the peak signal voltage applied to each grid does not exceed the negative grid-bias voltage. Since the grids are never driven positive, grid rectification does not occur. In class AB<sub>2</sub> service, the peak signal voltage does exceed the grid bias with the result that the grids are driven positive and draw current on a portion of the positive half-cycle of signal voltage. The efficiency and power output of a class AB<sub>2</sub> amplifier are somewhat higher than for a class AB<sub>1</sub> amplifier.

Because of the flow of grid current in a class AB<sub>2</sub> amplifier, there is a loss of power in the grid circuit. The sum of this loss and the loss in the input transformer is equal to the total driving power required by the grid circuit. The driver stage should be capable of giving a power output considerably larger than this required power in order that distortion introduced in the grid circuit can be kept low. The input transformer used in a class AB<sub>2</sub> amplifier usually has a step-down turns ratio.

The d-c plate current in a class AB<sub>2</sub> amplifier varies over a considerable range and increases with the input signal. Because of this variation, the plate-voltage supply should have good regulation; otherwise, fluctuations in the voltage output of the power supply cause a decrease in power output and an increase in distortion. To obtain satisfactory regulation, it is usually advisable to use a choke-input filter in the power supply. A mercury-vapor rectifier tube is generally preferable to a high-vacuum rectifier because of the better regulation of mercury-vapor tubes. In all cases, the resistance of the filter chokes and power transformer should be as low as practical.

The negative grid bias for either a class AB<sub>1</sub> or a class AB<sub>2</sub> amplifier should be obtained from a fixed-voltage supply if the maximum power output capabilities of the class AB stage are to be realized. Cathode-resistor bias can be employed with a class AB<sub>1</sub> amplifier, although this bias method reduces power output and may increase distortion. The cathode resistor should be by-passed by a very large condenser in order to minimize distortion. It is often advisable to provide for individual adjustment of grid bias for each tube in a push-pull class AB stage. If separate bias supplies are used, they should each be by-passed by suitably large condensers to minimize degenerative effects.

## CLASS B AMPLIFIERS

The ideal class B amplifier is one in which the alternating component of plate current is an exact replica of the alternating grid voltage for the half-cycle when the grid is positive with respect to the bias voltage. The power output is proportional to the square of the exciting grid voltage. In class B service, the tube is operated so that the plate current is relatively low with no grid excitation.

When excitation is applied, there is no plate-current flow over a substantial part of the negative half-cycle. Plate current flows only during the least negative excursions of the exciting voltage. A considerable amount of second-harmonic and higher even-order-harmonic distortion is thus introduced into the power output of a single tube. However, with two tubes in a balanced push-pull circuit, the even harmonics are eliminated from the output. In such a circuit, therefore, two tubes can be employed as class B amplifiers to supply power output with very low distortion. Class B amplifiers are characterized by medium power output, medium plate efficiency, and a moderate ratio of power amplification. They are used for both radio- and audio-frequency amplification.

In class B audio amplifier service, the tubes must be used in a balanced circuit so that harmonic distortion can be kept sufficiently low. Figs. 2 and 3 illustrate class B audio operation. It is possible to drive the grids of the amplifier tubes positive by a certain amount and still obtain virtually undistorted output, provided sufficient driving power is available. This power is conveniently supplied

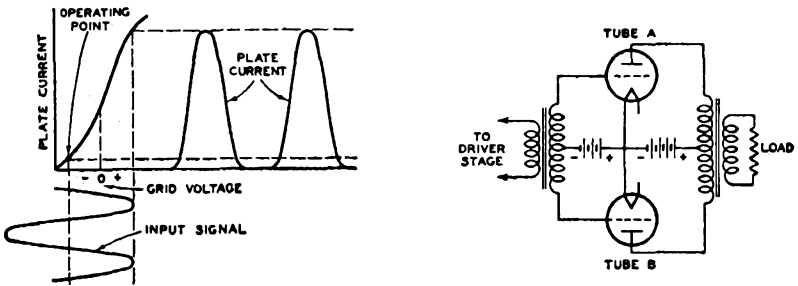

Fig. 2

by a class A or class AB power amplifier driving the grids of the output tubes through a suitable push-pull transformer. Where class B amplifier tubes are designed with a sufficiently high amplification factor, it is possible and convenient to operate them with zero grid bias, and so avoid the problem of providing a grid-bias supply having good voltage regulation. A modified remote-cut-off plate-current characteristic in such tubes is an important factor in obtaining low distortion.\* The 805 is an example of this type of tube design.

Distinguishing features of class B audio service are: High power output of

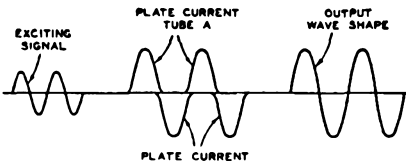

Fig. 3

good quality can be obtained with relatively small tubes operating at a fairly low plate voltage; and unusual overall economy of power consumption is possible because the average d-c plate current is low when no signal is applied to the grids. To give these advantages, a class B power amplifier requires the use of a driver stage capable of supplying considerable undistorted audio power and the use of a plate-voltage supply capable of maintaining good voltage regulation regardless of the variation of average plate current with signal voltage. It should be noted that the distortion present in the output of class B amplifiers is usually somewhat higher for the ordinary range of signals than that obtained with class A audio amplifiers employing much larger tubes capable of the same maximum power output.

L. E. Barton, "Recent Developments of the Class B Audio- and Radio-Frequency Amplifiers" Proc. I.R.E., July, 1936.

Because the average d-c plate current in a class B audio amplifier fluctuates considerably between no-signal and full-signal conditions, the plate supply should have adequate voltage regulation to take care not only of the average power requirements but also of the peak power demands. When an a-c operated power supply is used, the rectifier tube itself should have good regulation—a requirement which is usually met by the use of mercury-vapor rectifiers. The filter chokes and transformer windings should have low resistance.

The grid of a class B audio amplifier tube is usually operated sufficiently positive to cause current to flow in the grid circuit. Therefore, the driver stage must supply not only the necessary input voltage to the class B stage, but it must be capable of doing so under conditions where considerable power is taken by the grids of the class B amplifier tubes. Because the power necessary to swing the grids positive is partially dependent on the plate load of the class B tubes, and because the efficiency of power transfer from the driver stage is dependent on transformer characteristics, the design of a class B audio power amplifier requires more than ordinary attention to effects produced by the component parts of the circuit. For this reason, the design of a class B audio amplifier with its driver stage is more involved than that of a class A system.

The interstage transformer is the coupling link between the driver and the class B stage. It is usually made with a step-down ratio of primary to one-half secondary. This means that the primary voltage is higher than the secondary voltage applied to the grid of either class B tube. The step-down ratio depends on the following factors: Type of driver tube; type of class B power tube; load on class B power tube; permissible distortion; and transformer peak-power efficiency. In practice, the ratio of primary to one-half secondary may range between 1 to 1 and 5 to 1.

The class B input transformer should be designed to give good frequency response when operated into an open circuit, such as that represented by the class B stage when the signal amplitude is very small. It should have fairly high power efficiency so that it can deliver the required power when the signal amplitude is large. The power output and distortion of the class B stage are often critically dependent on the circuit constants, which should be made as nearly independent of frequency as possible. This applies particularly to the class B input transformer. Because it is difficult to compensate for the effects of leakage inductance in this transformer without excessive loss of high-frequency response, its leakage inductance should be as low as possible.

The type of tube chosen for the driver stage should be capable of supplying sufficient undistorted power to operate the class B stage at full output. Allowance should be made for the efficiency of the interstage transformer. Two low-impedance tubes are frequently used in a push-pull class A circuit for the driver stage. This arrangement not only delivers relatively large amounts of undistorted power but, because of the bucking action of the d-c currents flowing in each half of the primary, also frees the interstage transformer of undesirable d-c magnetization effects. It is often necessary, in order that distortion may be kept low, to work the driver tube into a load resistance higher than the normal value. The higher load reduces the distortion in the output of the driver stage, and consequently helps to reduce the distortion in the output of the class B stage.

A chart listing triodes suitable for class B audio service, with essential operating conditions and suggested driver tubes, is included in TRANSMITTER DESIGN CONSIDERATIONS.

In radio-telephone transmitters, a class B audio amplifier is generally used to modulate the plate voltage of a class C r-f amplifier, which may be either the final (output) stage, or some low-power stage preceding the final r-f amplifier. Coupling between the modulator and the class C stage is generally made by means of an output transformer, which should be designed so that the resistance load on the secondary, presented by the class C stage, is reflected into the primary



circuit as the plate-to-plate load specified in the modulator tube data. The output transformer should have low leakage inductance and should be designed with a core sufficiently large to avoid magnetic saturation effects which would impair the quality of the output. For best low-frequency response, it is preferable not to allow the d-c plate current of the r-f amplifier to flow through the secondary winding of the class B output transformer. Coupling between the secondary and the r-f stage to be modulated can be made through a series condenser and a parallel choke, as shown in circuit No. 13 in the CIRCUIT SECTION. If the secondary is to carry d-c plate current, the transformer core should be made larger and should include a suitable air gap to prevent magnetic saturation due to d-c magnetization.

The proper turns ratio for the output transformer is determined by the plate voltage and plate current of the class C stage to be modulated, together with the recommended plate-to-plate load of the class B modulator. For example, it is desired to operate two 805's as class B modulators with a plate supply of 1250 volts. The rated tube output is 300 watts and the recommended plate-to-plate load is 6700 ohms. If the efficiency of the class B output transformer is assumed to be 90 per cent, there will be  $0.9 \times 300$ , or 270 watts of useful audio power available. Because the power input to the class C r-f stage can be twice this value, for 100 per cent sinusoidal modulation, the class C amplifier can be operated at 2000 volts and 270 milliamperes, 1000 volts and 540 milliamperes, or at any other voltage and current providing an input of 540 watts. For the 2000-volt conditions, the equivalent resistance (sometimes called **modulation impedance**) of the class C stage is  $2000/0.270$ , or 7400 ohms. The turns ratio of the output transformer (total secondary to total primary) is equal to the square root of the impedance ratio: thus,  $\sqrt{7400/6700} = 1.1$ . This is a step-up ratio, because the load on the secondary is higher than the desired plate-to-plate load for the modulator.

The **plate-circuit efficiency** of a class B a-f amplifier is in the order of 50 to 65 per cent at full output.

**Grid bias** for tubes operated in class B a-f service should be obtained from a battery or other d-c source of good regulation. It should not be obtained from a high-resistance supply, such as a grid leak or a cathode resistor, nor from a rectifier, unless the latter is designed to have exceptionally good voltage regulation.

As a **class B radio-frequency amplifier**, any tube rated for such service may be operated in single-ended as well as in push-pull circuits. Either kind of operation is practical, because harmonic distortion in a class B r-f amplifier is largely filtered out by the "fly-wheel" action of the tuned output circuit. A typical circuit of a class B r-f amplifier using two 806's is shown in the CIRCUIT SECTION.

Where the final r-f stage of a transmitter is modulated, the term **high-level modulation** is used to describe the system because modulation takes place in the stage operating at the highest power level. Where modulation takes place in some intermediate stage preceding the final r-f amplifier, the term **low-level modulation** is employed. In the latter system, the plate of the final amplifier is supplied with unmodulated d-c voltage and the grid is excited by r-f voltage modulated at audio frequency in some preceding stage. The final amplifier is known as a linear amplifier and is operated under class B conditions so that the power output is proportional to the square of the exciting voltage. Thus, when the r-f grid voltage is doubled, the output of the class B r-f amplifier is increased four times and 100 per cent modulation is obtained.

Because the input impedance of a class B linear r-f amplifier varies considerably with variation in the modulated r-f grid voltage, it is essential that the r-f stage driving the linear amplifier have good regulation. This requirement can be met by means of a capacitive or inductive step-down of r-f voltage between the plate circuit of the modulated class C stage and the input circuit of the class B amplifier.

The use of a low-impedance modulator together with a fairly large voltage step-down from the plate tank circuit of the modulated class C amplifier is an aid in obtaining satisfactory regulation.\* Another, but less efficient, way of obtaining good regulation is by means of a non-inductive resistor of suitable value shunted across the input circuit of the class B r-f amplifier. This grid-regulation resistor (see circuit No. 21 in the CIRCUIT SECTION) should be of adequate size to dissipate a considerable portion of the exciting amplifier's power output. Adjustment of this resistance value, of grid bias, of grid excitation, and of antenna loading are important factors in obtaining proper operation. The average d-c plate current of a class B r-f amplifier should remain substantially constant as the modulation is varied between zero and 100 per cent.

Pentodes, tetrodes, and triodes can be used in class B r-f amplifier service. In the case of pentodes and tetrodes, the screen voltage should be obtained from a separate source, or from a potentiometer or voltage divider connected across the plate supply. The suppressor voltage for pentodes may be obtained from any fixed d-c supply. In cases where the suppressor draws current, the supply should be a battery or other d-c source of good regulation.

The plate-circuit efficiency of an unmodulated class B r-f amplifier is in the order of 30 per cent. At 100 per cent modulation, the efficiency rises to approximately 60 per cent. Because the plate dissipation is greatest when the carrier is unmodulated, care should be taken to limit the plate dissipation for the unmodulated condition to the maximum rating of the tube in this class of service.

Grid bias for class B r-f service may be obtained in the same manner as for class B a-f service, or by means of a cathode resistor (self-bias). Bias should not be obtained from a high-resistance source, such as a grid leak, nor from a power supply having poor voltage regulation. When self-bias is employed, the cathode resistor should be by-passed for both audio and radio frequencies.

## CLASS C AMPLIFIERS

A class C amplifier is one in which high plate-circuit efficiency and high power output are the primary considerations. In an ideal case, the alternating component of plate current is directly proportional to plate voltage, so that within wide limits the power output varies as the square of plate voltage. The tube is operated with a negative grid bias considerably higher than the value necessary to cause plate-current cut-off. An r-f grid voltage of sufficient amplitude is applied so that large amplitudes of plate current flow during a small fraction of the least-negative half-cycle of the exciting voltage. The grid is usually swung sufficiently positive to cause plate-current saturation. The resulting harmonics in the output waves are, to a large degree, filtered out by the "fly-wheel" action of the tuned plate circuit. Fig. 4 illustrates class C operation:

Distinguishing characteristics of class C amplification are high plate-circuit efficiency, high power output, and relatively low power amplification. Because power output varies as the square of plate voltage, a class C amplifier is capable of being modulated linearly by variation of plate voltage at audio frequency. In class C telephony service, the negative grid bias employed is usually two or more

\* See footnote on page 22.

times the value required to reduce the plate current to zero with no r-f grid excitation. The cut-off value of grid bias for a particular plate voltage can be obtained from the plate characteristics curves. Class C amplifiers are at present used almost exclusively as radio-frequency power amplifiers.

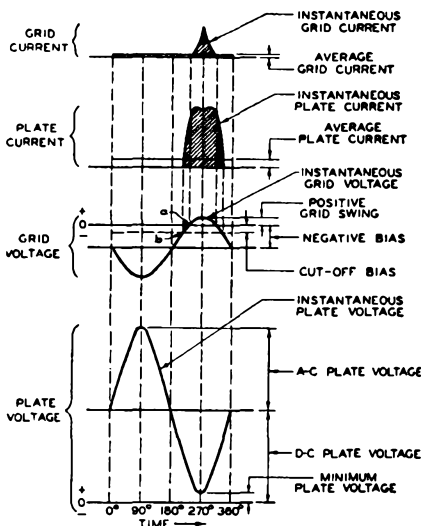

Fig. 4

In plate-modulated class C telephony service, a tube is operated with a d-c plate voltage on which has been superimposed an audio-frequency voltage. The amplitude of this a-f voltage varies with the intensity of the modulating signal. The largest a-c voltage that may be superimposed without introducing serious distortion is one whose peak amplitude just equals the d-c plate voltage. This is the condition necessary for 100 per cent modulation. Thus, when the r-f carrier is fully modulated, the modulating voltage drives the instantaneous plate voltage up to twice its normal d-c value and down to zero during each audio cycle. The ratio of the peak audio modulating voltage to the d-c plate voltage is called the **modulation factor**. Circuit No. 20 in the **CIRCUIT SECTION** shows the connections for a typical class C amplifier pentode (type 803) in plate-modulated telephony service.

In order to have distortionless modulation, it is essential that a linear relationship exist between currents and voltages. Thus, as the instantaneous plate voltage  $e_p$  is doubled, the r-f output voltage and current must also double. Likewise, as  $e_p$  is driven to zero on the negative half-cycle of the modulating voltage, the input and output currents must fall to zero. Averaged over an audio cycle, however, the d-c supply voltage and current ( $E_b$  and  $I_b$ ) remain constant, because the superimposed audio variations are symmetrical about the d-c values. Since, at 100 per cent modulation, the peak modulating voltage and current equal the d-c supply voltage and current, the RMS values of the audio components are equal to  $E_b/\sqrt{2}$  and  $I_b/\sqrt{2}$ . Therefore, the audio-frequency modulating power, being the product of the RMS voltage and the RMS current, is equal to  $E_b I_b / 2$ ; this means that the modulator must be able to supply audio power equal to one-half of the d-c plate input to the class C r-f amplifier.

When an r-f amplifier is modulated 100 per cent, the total input power is the sum of the d-c power input and the a-f power input,  $E_b I_b$  plus  $E_b I_b / 2$ , or  $3E_b I_b / 2$ . The total input power, therefore, is increased 50 per cent when the amplifier is modulated. The radio-frequency modulated carrier power is also increased 50 per cent, since the energy in the side bands is then 50 per cent of the carrier power. The plate losses likewise rise 50 per cent, because the efficiency of a class C amplifier is almost constant whether it is modulated or unmodulated. In order to allow for this level of plate dissipation, it is necessary for the plate

losses under unmodulated-carrier conditions to be limited to 2/3 of the maximum rated plate dissipation of the tube. Then, with sustained modulation at the 100 per cent level, the maximum rated plate dissipation will not be exceeded. These considerations account for the lower plate-dissipation ratings of tubes in plate-modulated class C service.

Triodes, tetrodes, and pentodes can be plate-modulated 100 per cent. To effect 100 per cent modulation of tetrodes and pentodes, it is necessary to modulate their screen voltage as well as their plate voltage. The screen voltage may be obtained from a fixed supply or from a voltage-dropping resistor in series with the plate supply. The screen voltage should be modulated simultaneously with the plate voltage so that the percentage changes in both voltages are approximately equal. Modulation of a fixed screen-voltage supply can be accomplished either by connecting the screen to a separate winding on the modulation transformer or by connecting it through a blocking condenser to a tap on the modulation transformer or choke. With the latter method, an a-f choke of suitable impedance for low audio frequencies should be connected in series with the screen-supply lead.

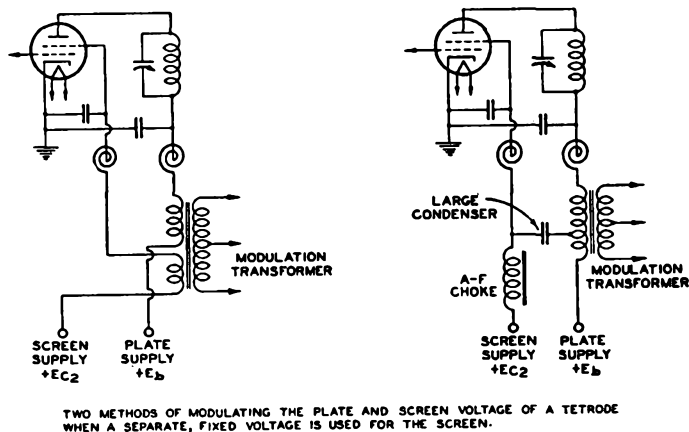

Fig. 5

Fig. 5 shows these connections. Where the series-screen-resistor method is used to obtain the screen voltage for pentodes, the screen resistor should be connected to the modulated plate supply; for tetrodes, to the unmodulated plate supply (see circuits Nos. 20 and 11, respectively, in the CIRCUIT SECTION). In the case of tetrodes, self-modulation of the screen voltage occurs due to variations in screen current as the plate voltage is modulated. The suppressor voltage for pentodes in plate-modulated service may be obtained from any fixed supply. Pentodes can also be used as tetrodes in this class of service, with the suppressor tied to the screen. The screen resistor for plate-modulated beam power tubes should be connected the same as for pentodes.

The plate-circuit efficiency of plate-modulated class C amplifiers is usually in the order of 65 to 75 per cent, although a higher efficiency can be obtained.

Grid bias for plate-modulated amplifiers is usually higher than for unmodulated amplifiers. Furthermore, the bias must change with modulation in the plate circuit, if linear operation over the entire audio-frequency cycle is to be obtained.\* It follows, therefore, that a bias supply having poor voltage regulation is desirable for plate-modulated class C amplifiers. In practice, this poor regulation can be obtained quite easily by the use of a grid-leak resistor to develop the bias voltage. The control-grid bias may also be obtained from a combination of either grid leak and fixed supply, or of grid leak and cathode resistor. A suitably designed bias rectifier may also be employed to give a bias voltage with the poor regulation desired. If a cathode resistor is used to supply part of the bias voltage, the resistor should be by-passed for both audio and radio frequencies. Grid-bias voltage for class C service is not critical, so that correct adjustment can be obtained with values differing widely from those shown under TYPICAL OPERATION for each tube type.

In **grid-modulated class C telephony service**, a tube is operated with an unmodulated r-f grid excitation voltage and with a d-c grid bias on which has been superimposed an audio-frequency signal. The plate is supplied with unmodulated d-c voltage. The operating conditions with an unmodulated carrier should be adjusted so that the r-f voltage in the plate circuit can be made to double at the crest of the audio cycle. Because the d-c plate voltage is the same under carrier and modulated conditions, the developed plate-voltage swing under carrier conditions can utilize only about half of the d-c supply voltage. The limited plate-voltage swing under carrier conditions causes the r-f output to be low and the plate-circuit efficiency to be poor—about one-half that of an unmodulated class C amplifier. The maximum tube ratings for grid-modulated class C service are the same as for class B r-f amplifier service. Satisfactory operating conditions for grid-modulated r-f amplifiers can be obtained from the tabulated class B r-f amplifier data, as follows:

- (1) Increase the listed value of d-c grid bias by a value equal to or greater than the listed value of peak r-f grid voltage.
- (2) Increase the listed value of peak r-f grid voltage by the same number of volts that the grid bias is increased.
- (3) The peak a-f grid voltage equals the listed (class B) peak r-f grid voltage.
- (4) The grid current through the modulating source at the positive peak of the a-f cycle equals the listed driving power divided by two times the listed peak r-f grid voltage. This current consists of a d-c component having one-half the value given above and an a-f component whose peak value is equal to that of the d-c component.
- (5) The carrier power output is approximately the same as the listed value of power output, although the d-c plate current is somewhat less than the listed plate current.
- (6) The r-f driving power at the crest of the a-f cycle is approximately the same as the listed class B value.

\* See reference No. 9 in the READING LIST.

The audio power required for grid-modulated service is relatively low, because modulation takes place in the control-grid circuit. However, the modulator must be capable of supplying the necessary peak power taken by the grid of the class C amplifier on the positive crest of the signal and should not produce distortion under the varying load of the grid circuit during the remainder of the cycle. The r-f excitation voltage and the d-c bias supply should have good regulation. The grid bias should not be obtained from a high-resistance supply, such as a grid leak or a cathode resistor. The plate-circuit losses are at a maximum under carrier conditions; therefore, the plate dissipation under these conditions should not be allowed to exceed the maximum rated value. The efficiency increases and the plate loss decreases when the carrier is modulated.

For grid-modulated pentodes and tetrodes, the screen voltage should be obtained from a separate source or from a potentiometer connected across the plate supply. The suppressor voltage for pentodes may be obtained from any fixed supply.

In suppressor-modulated class C r-f amplifier service, pentodes may be operated as shown in the tabulated data under each type. The plate is supplied with unmodulated d-c voltage, the control grid (grid No. 1) with unmodulated r-f voltage, and the suppressor (grid No. 3) with a negative d-c voltage modulated at audio frequency. The voltage for the screen (grid No. 2) should be obtained from the plate supply through a series resistor (see circuit No. 14 in the CIRCUIT SECTION). The suppressor bias may be taken from any fixed-voltage d-c supply; this supply should have good regulation in circuits where the suppressor draws current. Control-grid bias may be obtained by any of the methods given under TRANSMITTING-TUBE INSTALLATION. If cathode-resistor bias is employed, the resistor should be by-passed for both audio and radio frequencies. As in other types of class C service, the control-grid bias is not particularly critical.

The plate-circuit efficiency of a suppressor-modulated amplifier is in the order of 30 to 35 per cent. This moderate efficiency is due to the fact that the plate voltage is fixed and that the tube must be operated so as to allow the r-f plate voltage and current to double at the crest of the audio cycle. In this respect, operation is similar to that of a class B linear r-f amplifier.

Suppressor modulation has the advantage of requiring very little audio power for 100 per cent modulation. For example, a modulator delivering about one watt of audio power is capable of fully modulating one RCA-803. The suppressor is operated with sufficient negative bias so that, under carrier conditions, the r-f output voltage and current equal half the values reached at the crest of the a-f cycle. As a result, the suppressor does not draw current except on a portion of the positive half-cycle of modulating voltage. The modulator, which may be either transformer or impedance coupled to the suppressor, must be capable of delivering sufficient audio power to supply that required by the suppressor on the positive half-cycles, and to supply it without introducing serious distortion during the time that suppressor current flows.

In class C r-f amplifier or oscillator service for telegraphy, a tube is operated with an unmodulated d-c plate voltage. The control grid is supplied with a negative bias voltage and is excited by an unmodulated r-f voltage. The screen of a tetrode or a pentode is supplied with a positive d-c voltage. The suppressor of a pentode may be operated with a small positive d-c voltage or it may be tied to the cathode and thus operated at zero potential. In the former case, the power output of a pentode is slightly increased. Screen, suppressor, and control-grid voltages may be obtained by any of the methods described under TRANSMITTING-TUBE INSTALLATION. Screen-voltage exceptions are noted in the tabulated data under the tube type.

Because the output of a class C amplifier in telegraph service must be interrupted so as to form dots and dashes for the communication of intelligence, the subject of keying is of considerable importance. Satisfactory keying is accomplished when the power output of the amplifier is reduced to zero almost instantaneously with the opening of the key and when full power output is delivered almost instantaneously with the closing of the key.

The power output of a vacuum-tube r-f amplifier can be controlled by either of two general methods, each of which is capable of a number of variations. These general methods are: direct control of the d-c plate input by switching the plate voltage off and on; and control of the excitation supplied to the control grid of the amplifier. The design of a satisfactory keying system involves many problems, the solutions of which are not within the scope of this book. The keying circuit selected should operate so that when the key is opened, no voltage, current, or dissipation rating of the tube will be exceeded.

When a tetrode or a pentode is to be keyed, the screen voltage is preferably obtained from a separate source or from a voltage divider. However, the series-screen-resistor method may be used with some tubes, as shown in the data under the tube type.

The grid excitation of a triode (except one having a sufficiently high  $\mu$ ) should not be interrupted when grid-leak bias is employed; otherwise, the plate dissipation rating of the tube will be exceeded due to the resultant rise in d-c plate current. To avoid this difficulty, a suitable value of fixed-bias voltage should be used. For additional information on keying methods, see references No. 14 and No. 23 in the READING LIST.

## Frequency Multipliers

Because the plate-current waves of a class C amplifier contain a relatively high percentage of harmonics, an amplifier of this type can readily be employed to double or triple the frequency of the r-f exciting voltage. The harmonic output can be increased by using a bias voltage higher than for class C amplifier service. It is common practice to employ a low-frequency crystal oscillator whose frequency has a sub-multiple relation to the desired operating frequency, in conjunction with one or more class C frequency multipliers. Thus, a 3500-kilocycle crystal oscillator can be used with several frequency doublers to provide an r-f voltage having a frequency of 7000 kc, 14000 kc, 28000 kc, etc. The plate circuit of a frequency multiplier is tuned to the frequency of the harmonic which is to be amplified. Triodes, tetrodes, and pentodes can be used in this class of service. Pentodes as frequency multipliers generally provide more output for a given input than triodes or tetrodes; high- $\mu$  triodes are somewhat better than low- $\mu$  triodes. Frequency quadrupling is often not satisfactory, because the amplitude of the fourth harmonic is usually quite small. The loss in power at the fourth harmonic is usually great enough to necessitate the use of an additional amplifier stage, unless special circuit arrangements are used (see Reinartz' harmonic generator circuit, No. 6 in the CIRCUIT SECTION). The efficiency of a tube used as a class C plate-circuit frequency multiplier is considerably less than when it is used as a class C amplifier. An efficiency of 50 to 60 per cent is typical for doublers; the value decreases rapidly as the harmonic frequency is increased. Neutralization of frequency multipliers is not essential, because the plate circuit does not operate at the same frequency as the grid circuit. The use of a neutralizing circuit, however, provides somewhat higher power output due to the feedback thus introduced.

A frequency doubler having better regulation is obtained by operating two tubes in a balanced-input circuit with the grids in push-pull and the plates in

parallel (see circuit No. 7 in the CIRCUIT SECTION). The plate circuit, tuned to twice the frequency of the exciting voltage, receives two pulses of plate current for each complete cycle of grid excitation voltage; the power output obtained is about twice that of a single-tube doubler.

### Crystal-Controlled Oscillators

Because of their general use in controlling the frequency of radio transmitters of many types, crystal-controlled oscillators are of considerable importance. Due to the fragile nature of crystals, especially those ground for high-frequency operation, and to the small amount of power they are capable of handling, it is general practice to use them in conjunction with oscillator tubes of relatively low power. Triodes, tetrodes, and pentodes can be used as crystal-controlled oscillators. In the case of a triode, such as the 801, the plate voltage should be reduced to about one-third of its normal value, to prevent overloading the crystal by excessive feedback and heavy r-f currents. Pentodes, such as the 802, and beam power tubes, such as the 807, are especially suitable for crystal-oscillator service. They cause relatively little loading of the crystal in properly designed circuits, even when operated at full plate voltage. In addition, they will deliver considerably more power output than triodes of similar size, due partly to the higher d-c plate input at which they can be operated and partly to their higher power sensitivity. In the case of tetrodes and pentodes, which have efficient screening between the control grid and the plate, it is usually necessary to introduce some external grid-plate capacitance in circuits where oscillation depends upon the feedback produced by this capacitance. The external feedback may be obtained by means of a small adjustable condenser (usually not larger than 2 or 3  $\mu\text{f}$ ) connected between the grid terminal and the plate terminal. The extra capacitance should not be made larger than necessary, because an excessive value may cause sufficient feedback to overload and destroy a crystal. Typical crystal-oscillator circuits are shown in the CIRCUIT SECTION. In high-frequency transmitters where a low-frequency crystal is employed, special crystal-oscillator circuits are frequently used wherein frequency doubling or tripling is accomplished in the oscillator plate circuit. Such circuits have the advantage of reducing the number of frequency-multiplier stages needed.

### OTHER CONSIDERATIONS

In those classes of operation where d-c grid current is drawn, it will be found that the grid current will vary with individual tubes. Under no condition of operation should the grid-current values under MAXIMUM RATINGS be exceeded.

If more radio-frequency power output is required than can be obtained from a single tube, the push-pull, parallel, or push-pull parallel connection can be used. For example, two tubes connected in push-pull or in parallel will give approximately twice the power output of one tube. The parallel connection requires no increase in exciting voltage; the push-pull connection requires twice the exciting voltage necessary for a single tube. With either connection, the driving power required is approximately twice that for single-tube operation, while the d-c grid bias is the same as for a single tube. The push-pull arrangement has the advantage of cancelling the even-order harmonics from the output and of simplifying the balancing of high-frequency circuits. Where two or more tubes are operated in push-pull or in parallel, a non-inductive resistance of 10 to 100 ohms should be placed in series with the grid lead of each tube, close to the socket terminal, to prevent parasitic oscillations. Additional information on the application of transmitting tubes is given in the chapter on TRANSMITTER DESIGN CONSIDERATIONS.



# RCA-203-A

## R-F Power Amplifier, Oscillator, Class B Modulator

For illustration, refer to 838 on page 62

RCA-203-A is a three-electrode transmitting tube of the thoriated-tungsten filament type with a maximum plate dissipation rating of 100 watts for class C telegraph and class B services. As a radio-frequency amplifier or oscillator, the 203-A may be operated under maximum rated conditions at frequencies as high as 15 megacycles.

### CHARACTERISTICS

Filament Volts (a-c or d-c).....	10.0	Grid-Plate Capacitance .....	14.5 $\mu\text{f}$
Filament Amperes .....	3.25	Grid-Filament Capacitance .....	6.5 $\mu\text{f}$
Amplification Factor .....	25	Plate-Filament Capacitance .....	5.5 $\mu\text{f}$

### MAXIMUM RATINGS AND TYPICAL OPERATING CONDITIONS

#### As A-F Power Amplifier and Modulator—Class B

D-C PLATE VOLTAGE .....	1250 max.	Volts
MAX-SIGNAL D-C PLATE CURRENT* .....	175 max.	Milliamperes
MAX-SIGNAL PLATE INPUT* .....	220 max.	Watts
PLATE DISSIPATION* .....	100 max.	Watts

#### TYPICAL OPERATION:

Unless otherwise specified, values are for 2 tubes

D-C Plate Voltage .....	1000	1250	Volts
D-C Grid Voltage <sup>§</sup> .....	-35	-45	Volts
Peak A-F Grid-to-Grid Voltage .....	310	330	Volts
Zero-Signal D-C Plate Current .....	26	26	Milliamperes
Max-Signal D-C Plate Current .....	320	320	Milliamperes
Load Resistance (Per tube) .....	1725	2250	Ohms
Effective Load Res. (Plate-to-plate) .....	6900	9000	Ohms
Max-Signal Driving Power (Approx.) .....	10	11	Watts
Max-Signal Power Output (Approx.) .....	200	260	Watts

#### As R-F Power Amplifier—Class B Telephony

Carrier conditions per tube for use with a max. modulation factor of 1.0

D-C PLATE VOLTAGE .....	1250 max.	Volts
D-C PLATE CURRENT .....	150 max.	Milliamperes
PLATE INPUT .....	150 max.	Watts
PLATE DISSIPATION .....	100 max.	Watts

#### TYPICAL OPERATION:

D-C Plate Voltage .....	1000	1250	Volts
D-C Grid Voltage <sup>§</sup> .....	-35	-45	Volts
Peak R-F Grid Voltage .....	95	90	Volts
D-C Plate Current .....	130	106	Milliamperes
D-C Grid Current (Approx.) .....	5	3	Milliamperes
Driving Power (Approx.) <sup>†</sup> .....	5	3	Watts
Power Output (Approx.) .....	40	42.5	Watts

\*. §. †: see next page.

### As Plate-Modulated R-F Power Amplifier—Class C Telephony

Carrier conditions per tube for use with a max. modulation factor of 1.0

D-C PLATE VOLTAGE .....	1000 max.	Volts
D-C GRID VOLTAGE .....	-400 max.	Volts
D-C PLATE CURRENT .....	175 max.	Milliamperes
D-C GRID CURRENT .....	60 max.	Milliamperes
PLATE INPUT .....	175 max.	Watts
PLATE DISSIPATION .....	67 max.	Watts

TYPICAL OPERATION:

D-C Plate Voltage .....	750	1000	Volts
D-C Grid Voltage§ .....	-100	-135	Volts
Peak R-F Grid Voltage .....	235	275	Volts
D-C Plate Current .....	150	150	Milliamperes
D-C Grid Current (Approx.) .....	50	50	Milliamperes
Grid Resistor .....	2000	2700	Ohms
Driving Power (Approx.) .....	12	14	Watts
Power Output (Approx.) .....	65	100	Watts

### As R-F Power Amplifier and Oscillator—Class C Telegraphy

Key-down conditions per tube without modulation††

D-C PLATE VOLTAGE .....	1250 max.	Volts
D-C GRID VOLTAGE .....	-400 max.	Volts
D-C PLATE CURRENT .....	175 max.	Milliamperes
D-C GRID CURRENT .....	60 max.	Milliamperes
PLATE INPUT .....	220 max.	Watts
PLATE DISSIPATION .....	100 max.	Watts

TYPICAL OPERATION:

D-C Plate Voltage .....	750	1000	1250	Volts
D-C Grid Voltage§ .....	-75	-100	-125	Volts
Peak R-F Grid Voltage .....	195	225	255	Volts
D-C Plate Current .....	150	150	150	Milliamperes
D-C Grid Current (Approx.) .....	25	25	25	Milliamperes
Grid Resistor .....	3000	4000	5000	Ohms
Driving Power (Approx.) .....	5	6	7	Watts
Power Output (Approx.) .....	65	100	130	Watts

\* Averaged over any audio-frequency cycle of sine-wave form.

§ Grid voltages are given with respect to the mid-point of filament operated on a.c. If d.c. is used, each stated value of grid voltage should be decreased by 7 volts and the circuit returns made to the negative end of the filament.

† At crest of audio-frequency cycle with modulation factor of 1.0.

†† Modulation essentially negative may be used if the positive peak of the audio-frequency envelope does not exceed 115% of the carrier conditions.

## INSTALLATION AND APPLICATION

The base pins of the RCA-203-A fit the standard transmitting four-contact socket, such as the RCA type UT-541A. The socket should be installed so that the tube will operate in a vertical position with the base down.

The plate of the 203-A shows no color at the maximum plate-dissipation rating for each class of service.

For high-frequency operation above 15 megacycles, see page 144.

For additional information, see chapters on INSTALLATION and APPLICATION.

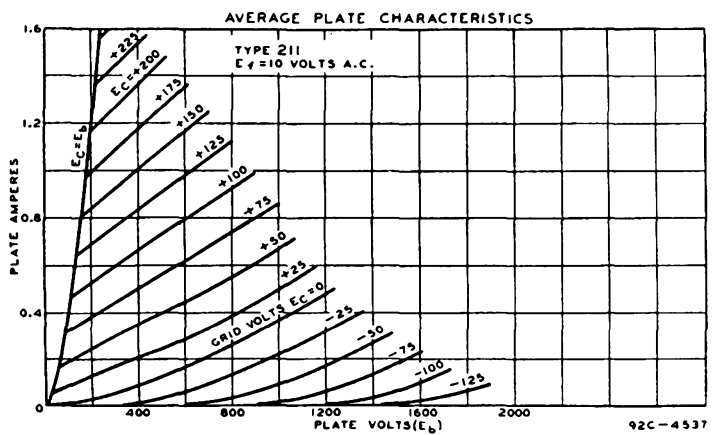
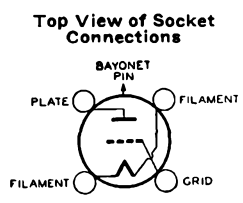
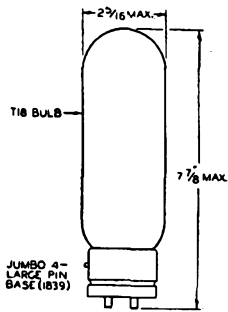
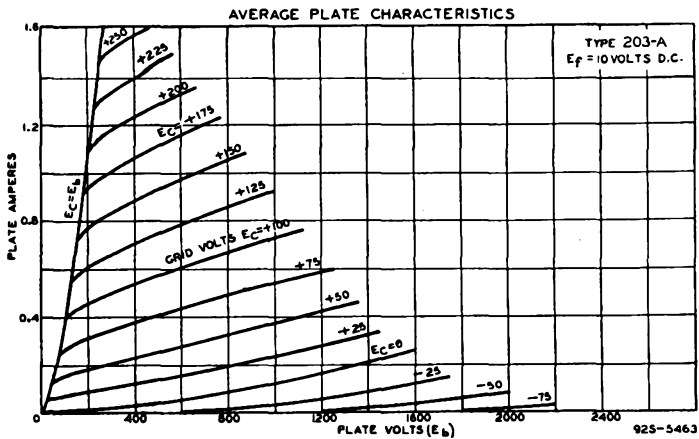

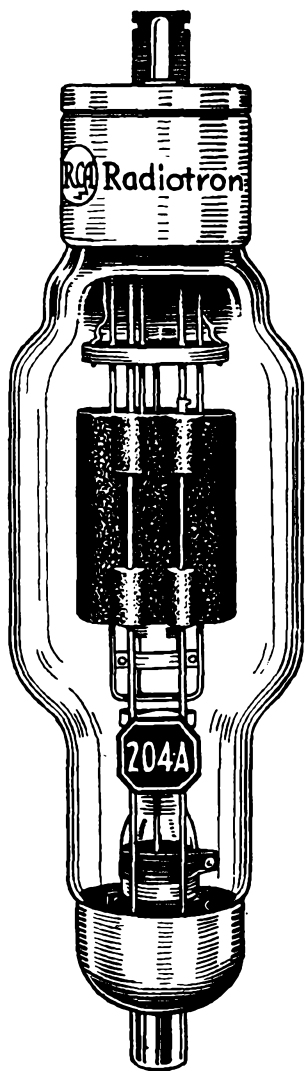

RCA-204-A

The old-reliable triode for commercial applications.

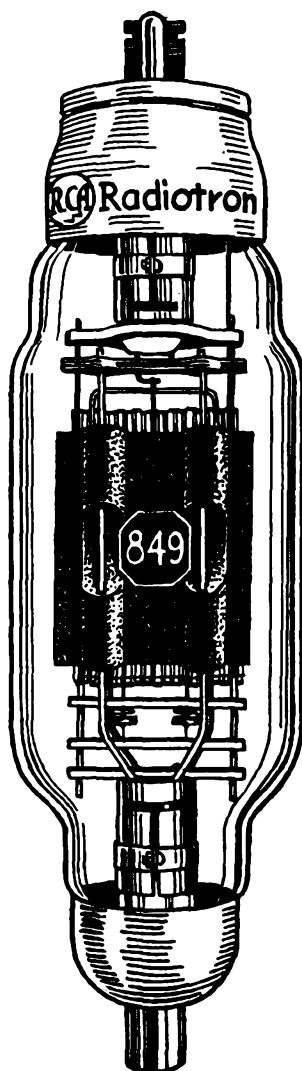

RCA-849

Heavy-duty triode—used in many broadcast and commercial transmitters.

# RCA-204-A

## R-F Power Amplifier, Oscillator, Class B Modulator

Illustrated on page 35

RCA-204-A is a three-electrode transmitting tube of the thoriated-tungsten filament type for use as a radio-frequency amplifier, oscillator, and class B audio-frequency amplifier. The grid and plate leads are brought out at opposite ends of the tube to insure good insulation. As a radio-frequency amplifier, the 204-A may be operated under maximum rated conditions at frequencies as high as 3 megacycles. The maximum plate dissipation is 250 watts for class C telegraph and class B services.

### CHARACTERISTICS

Filament Volts (a-c or d-c).....	11.0	Grid-Plate Capacitance .....	15 $\mu$ f
Filament Amperes .....	3.85	Grid-Filament Capacitance .....	12.5 $\mu$ f
Amplification Factor .....	23	Plate-Filament Capacitance .....	2.3 $\mu$ f

### MAXIMUM RATINGS AND TYPICAL OPERATING CONDITIONS

#### As A-F Power Amplifier and Modulator—Class B

D-C PLATE VOLTAGE.....	3000 max. Volts
MAX.-SIGNAL D-C PLATE CURRENT* .....	275 max. Milliamperes
MAX.-SIGNAL PLATE INPUT* .....	600 max. Watts
PLATE DISSIPATION* .....	250 max. Watts

#### TYPICAL OPERATION:

Unless otherwise specified, values are for 2 tubes

D-C Plate Voltage .....	2000	2500	3000	Volts
D-C Grid Voltage <sup>§</sup> .....	-60	-80	-100	Volts
Peak A-F Grid-to-Grid Voltage .....	500	500	500	Volts
Zero-Signal D-C Plate Current .....	80	80	80	Milliamperes
Max.-Signal D-C Plate Current .....	500	420	372	Milliamperes
Load Resistance (Per tube) .....	2200	3400	5000	Ohms
Effective Load Res. (Plate-to-plate) ..	8800	13600	20000	Ohms
Max.-Sig. Driving Power (Approx.) .....	20	18	18	Watts
Max.-Sig. Power Output (Approx.) .....	600	650	700	Watts

#### As R-F Power Amplifier—Class B Telephony

Carrier conditions per tube for use with a max. modulation factor of 1.0

D-C PLATE VOLTAGE .....	2500 max. Volts
D-C PLATE CURRENT .....	225 max. Milliamperes
PLATE INPUT .....	400 max. Watts
PLATE DISSIPATION .....	250 max. Watts

#### TYPICAL OPERATION:

D-C Plate Voltage .....	1500	2000	Volts
D-C Grid Voltage <sup>§</sup> .....	-50	-70	Volts
Peak R-F Grid Voltage .....	170	165	Volts
D-C Plate Current .....	200	160	Milliamperes
D-C Grid Current (Approx.) .....	7.5	5	Milliamperes
Driving Power (Approx.) <sup>†</sup> .....	18	15	Watts
Power Output (Approx.) .....	80	100	Watts

\* , § , †: see next page.

### As Plate-Modulated R-F Power Amplifier—Class C Telephony

Carrier conditions per tube for use with a max. modulation factor of 1.0

D-C PLATE VOLTAGE .....	2000	max.	Volts
D-C GRID VOLTAGE .....	-500	max.	Volts
D-C PLATE CURRENT .....	275	max.	Milliamperes
D-C GRID CURRENT .....	80	max.	Milliamperes
PLATE INPUT .....	550	max.	Watts
PLATE DISSIPATION .....	167	max.	Watts

**TYPICAL OPERATION:**

D-C Plate Voltage .....	1500	2000	Volts
D-C Grid Voltage <sup>§</sup> .....	-200	-250	Volts
Peak R-F Grid Voltage .....	450	500	Volts
D-C Plate Current .....	250	250	Milliamperes
D-C Grid Current (Approx.) .....	35	35	Milliamperes
Grid Resistor .....	5710	7140	Ohms
Driving Power (Approx.) .....	20	20	Watts
Power Output (Approx.) .....	225	350	Watts

### As R-F Power Amplifier and Oscillator—Class C Telegraphy

Key-down conditions per tube without modulation††

D-C PLATE VOLTAGE .....	2500	max.	Volts
D-C GRID VOLTAGE .....	-500	max.	Volts
D-C PLATE CURRENT .....	275	max.	Milliamperes
D-C GRID CURRENT .....	80	max.	Milliamperes
PLATE INPUT .....	690	max.	Watts
PLATE DISSIPATION .....	250	max.	Watts

**TYPICAL OPERATION:**

D-C Plate Voltage .....	1500	2000	2500	Volts
D-C Grid Voltage <sup>§</sup> .....	-150	-175	-200	Volts
Peak R-F Grid Voltage .....	400	425	440	Volts
D-C Plate Current .....	250	250	250	Milliamperes
D-C Grid Current (Approx.) .....	30	30	30	Milliamperes
Grid Resistor .....	5000	5835	6670	Ohms
Driving Power (Approx.) .....	15	15	15	Watts
Power Output (Approx.) .....	240	350	450	Watts

§ Grid voltages are given with respect to the mid-point of filament operated on a.c. If d.c. is used, each stated value of grid voltage should be decreased by 8 volts and the circuit returns made to the negative end of the filament.

\* Averaged over any audio-frequency cycle of sine-wave form.

† At crest of audio-frequency cycle with modulation factor of 1.0.

†† Modulation essentially negative may be used if the positive peak of the audio-frequency envelope does not exceed 115% of the carrier conditions.

## INSTALLATION AND APPLICATION

The base and cap of the RCA-204-A fit the standard RCA end-mountings, UT-1085 and UT-1086, respectively. The end-mountings should be installed to hold the tube in a vertical position with the filament base (large end) up. If it is necessary to place the tube in a horizontal position, the tube should be mounted with the plate in a vertical plane (on edge). The metal filament base must not be grounded or connected to any part of the circuit.

The plate of the 204-A shows only a barely perceptible red color at the maximum plate-dissipation rating for each class of service.

For high-frequency operation above 3 megacycles, see page 144.

For additional information, see chapters on INSTALLATION and APPLICATION.

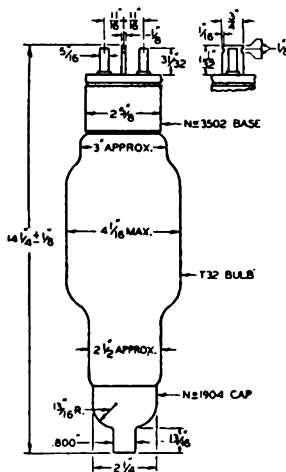
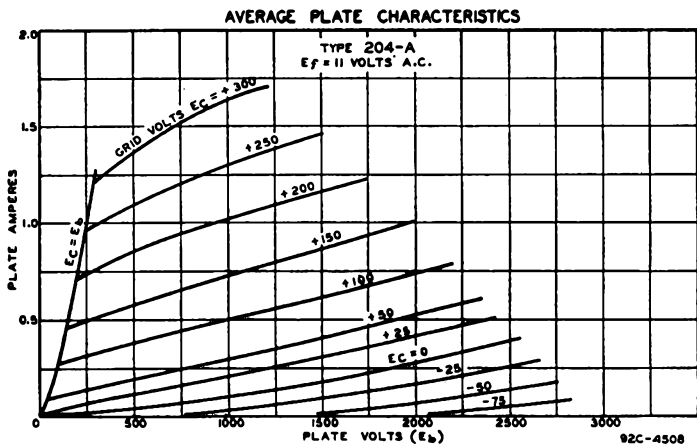

**Connections to End-Mountings**

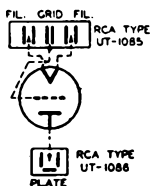

# RCA-211

## R-F Power Amplifier, Oscillator, Class B Modulator

For illustration, refer to 838 on page 62

RCA-211 is a three-electrode transmitting tube of the thoriated-tungsten filament type with a maximum plate dissipation of 100 watts for class C telegraph and class B services. As a radio-frequency amplifier or oscillator the 211 may be operated at maximum rated conditions at frequencies as high as 15 megacycles. It may also be used as a class B audio-frequency amplifier and modulator.

### CHARACTERISTICS

Filament Volts (a-c or d-c).....	10.0	Grid-Plate Capacitance .....	14.5 $\mu\text{f}$
Filament Amperes .....	3.25	Grid-Filament Capacitance .....	6 $\mu\text{f}$
Amplification Factor .....	12	Plate-Filament Capacitance .....	5.5 $\mu\text{f}$

### MAXIMUM RATINGS AND TYPICAL OPERATING CONDITIONS

#### As A-F Power Amplifier and Modulator—Class B

D-C PLATE VOLTAGE .....	1250	max.	Volts
MAX.-SIGNAL D-C PLATE CURRENT* .....	175	max.	Milliamperes
MAX.-SIGNAL PLATE INPUT* .....	220	max.	Watts
PLATE DISSIPATION* .....	100	max.	Watts

#### TYPICAL OPERATION:

Unless otherwise specified, values are for 2 tubes

D-C Plate Voltage .....	1000	1250	Volts
D-C Grid Voltage <sup>§</sup> .....	-77	-100	Volts
Peak A-F Grid-to-Grid Voltage .....	380	410	Volts
Zero-Sig. D-C Plate Current .....	20	20	Milliamperes
Max.-Sig. D-C Plate Current .....	320	320	Milliamperes
Load Resistance (Per tube) .....	1725	2250	Ohms
Effective Load Res. (Plate-to-plate) .....	6900	9000	Ohms
Max.-Sig. Driving Power (Approx.) .....	7.5	8	Watts
Max.-Sig. Power Output (Approx.) .....	200	260	Watts

#### As R-F Power Amplifier—Class B Telephony

Carrier conditions per tube for use with a max. modulation factor of 1.0

D-C PLATE VOLTAGE .....	1250	max.	Volts
D-C PLATE CURRENT .....	150	max.	Milliamperes
PLATE INPUT .....	150	max.	Watts
PLATE DISSIPATION .....	100	max.	Watts

#### TYPICAL OPERATION:

D-C Plate Voltage .....	1000	1250	Volts
D-C Grid Voltage <sup>§</sup> .....	-77	-100	Volts
Peak R-F Grid Voltage .....	125	125	Volts
D-C Plate Current .....	130	106	Milliamperes
D-C Grid Current (Approx.) .....	5	1	Milliamperes
Driving Power (Approx.) <sup>†</sup> .....	10	7.5	Watts
Power Output (Approx.) .....	40	42.5	Watts

\* , § , †: see next page.



### As Plate-Modulated R-F Power Amplifier—Class C Telephony

Carrier conditions per tube for use with a max. modulation factor of 1.0

D-C PLATE VOLTAGE .....	1000	max.	Volts
D-C GRID VOLTAGE .....	-400	max.	Volts
D-C PLATE CURRENT .....	175	max.	Milliamperes
D-C GRID CURRENT .....	50	max.	Milliamperes
PLATE INPUT .....	175	max.	Watts
PLATE DISSIPATION .....	67	max.	Watts

**TYPICAL OPERATION:**

D-C Plate Voltage .....	750	1000	Volts
D-C Grid Voltage <sup>§</sup> .....	-200	-260	Volts
Peak R-F Grid Voltage .....	350	410	Volts
D-C Plate Current .....	150	150	Milliamperes
D-C Grid Current (Approx.) .....	35	35	Milliamperes
Grid <sup>†</sup> Resistor .....	5710	7430	Ohms
Driving Power (Approx.) .....	12	14	Watts
Power Output (Approx.) .....	65	100	Watts

### As R-F Power Amplifier and Oscillator—Class C Telegraphy

Key-down conditions per tube without modulation<sup>††</sup>

D-C PLATE VOLTAGE .....	1250	max.	Volts
D-C GRID VOLTAGE .....	-400	max.	Volts
D-C PLATE CURRENT .....	175	max.	Milliamperes
D-C GRID CURRENT .....	50	max.	Milliamperes
PLATE INPUT .....	220	max.	Watts
PLATE DISSIPATION .....	100	max.	Watts

**TYPICAL OPERATION:**

D-C Plate Voltage .....	750	1000	1250	Volts
D-C Grid Voltage <sup>§</sup> .....	-135	-175	-225	Volts
Peak R-F Grid Voltage .....	275	315	375	Volts
D-C Plate Current .....	150	150	150	Milliamperes
D-C Grid Current (Approx.) .....	18	18	18	Milliamperes
Grid Resistor .....	7500	9725	12500	Ohms
Driving Power (Approx.) .....	5	6	7	Watts
Power Output (Approx.) .....	65	100	130	Watts

\* Averaged over any audio-frequency cycle of sine-wave form.

§ Grid voltages are given with respect to the mid-point of filament operated on a.c. If d.c. is used, each stated value of grid voltage should be decreased by 7 volts and the circuit returns made to the negative end of the filament.

† At crest of audio-frequency cycle with modulation factor of 1.0.

†† Modulation essentially negative may be used if the positive peak of the audio-frequency envelope does not exceed 115% of the carrier conditions.

## INSTALLATION AND APPLICATION

For socket type and outline drawing, refer to type 203-A.

The plate of the 211 shows only a barely perceptible red color at the maximum plate dissipation rating for each class of service.

For high-frequency operation above 15 megacycles, see page 144.

For additional information, see chapters on INSTALLATION and APPLICATION.

A plate family of curves is shown at the bottom of page 34.

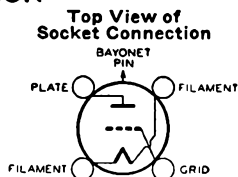

# RCA-217-A and RCA-217-C

## Half-Wave, High-Vacuum Rectifiers

RCA-217-A and RCA-217-C are half-wave, high-vacuum rectifiers of the thoriated-tungsten filament type. They are for use in high-voltage rectifying devices where freedom from r-f disturbances in the output is an important factor. In single-phase circuits, full-wave rectification is obtained by using two of these types. The major difference between the two tubes is the higher plate-voltage rating of the 217-C.

### CHARACTERISTICS

	RCA-217-A	RCA-217-C	
FILAMENT VOLTAGE (a-c) .....	10.0	10.0	Volts
FILAMENT CURRENT .....	3.25	3.25	Amperes
PEAK INVERSE VOLTAGE .....	3500 max.	7500 max.	Volts
PEAK PLATE CURRENT .....	0.6 max.	0.6 max.	Ampere
AVERAGE PLATE CURRENT .....	0.2 max.	0.15 max.	Ampere

The bases of the 217-A and 217-C fit the standard transmitting 4-contact sockets, such as the RCA type UT-541A. The sockets should be mounted to hold the tubes in a vertical position with the base ends of the tubes down. Due to the high-voltage rating of the 217-C, the metal shell of the socket holding this tube must not be grounded nor connected to any other part of the circuit. The plate lead of the 217-C is brought out to the cap at the top of the bulb.

The outline drawing of the 217-A is the same as that of the 203-A; the outline drawing of the 217-C is the same as that of the 805.

For additional information, see chapter on RECTIFIERS and FILTERS.

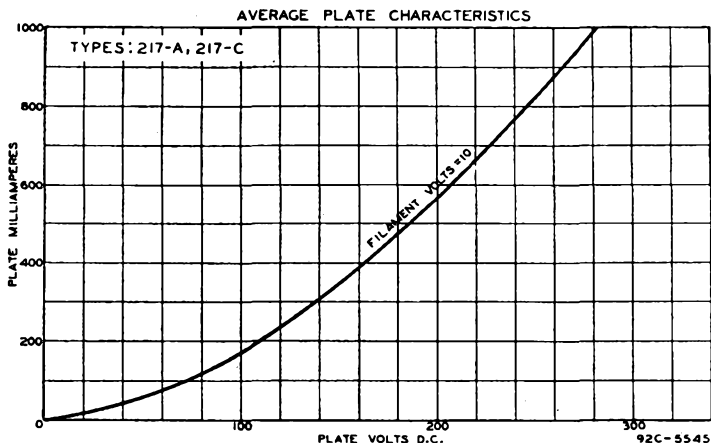

Top View of Socket Connections

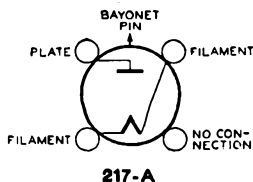

Top View of Socket Connections

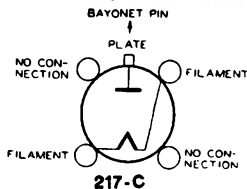

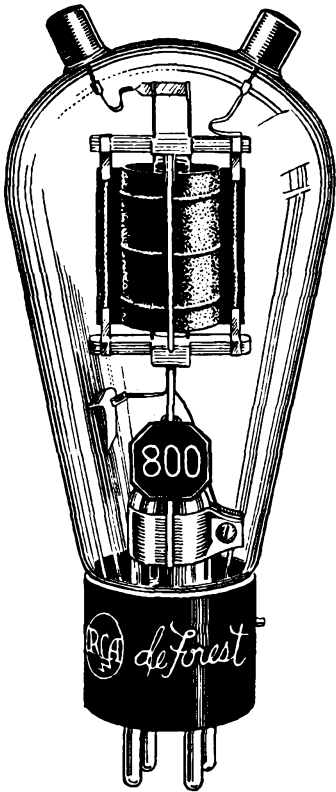

**RCA-800**

Triode—100 watts input up to 60 megacycles — good ultra-high-frequency tube.

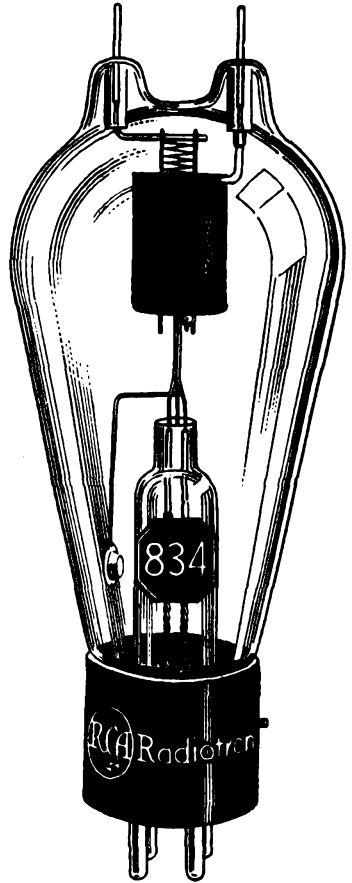

**RCA-834**

Triode—full rated input to 100 megacycles—50 watts plate dissipation—designed primarily for ultra-high-frequency applications.

# RCA-800

## R-F Power Amplifier, Oscillator, Class B Modulator

RCA-800 is a three-electrode transmitting tube of the thoriated-tungsten filament type designed for use as a radio-frequency amplifier or oscillator, particularly at the higher radio frequencies. It may be operated at maximum ratings at frequencies as high as 60 megacycles. The maximum plate dissipation for class B and class C telegraph services is 35 watts. The grid and plate leads of the 800 are brought out through separate seals at the top of the bulb to insure high insulation and low interelectrode capacitances.

### CHARACTERISTICS

Filament Volts (a-c or d-c).....	7.5	Grid-Plate Capacitance .....	2.5 $\mu\text{f}$
Filament Amperes .....	3.25	Grid-Filament Capacitance .....	2.75 $\mu\text{f}$
Amplification Factor .....	15	Plate-Filament Capacitance .....	2.75 $\mu\text{f}$

### MAXIMUM RATINGS AND TYPICAL OPERATING CONDITIONS

#### As A-F Power Amplifier and Modulator—Class B

D-C PLATE VOLTAGE .....	1250 max.	Volts
MAX.-SIGNAL D-C PLATE CURRENT* .....	115 max.	Milliamperes
MAX.-SIGNAL PLATE INPUT* .....	85 max.	Watts
PLATE DISSIPATION* .....	35 max.	Watts

#### TYPICAL OPERATION:

*Unless otherwise specified, values are for 2 tubes*

D-C Plate Voltage .....	750	1000	1250	Volts
D-C Grid Voltage <sup>§</sup> .....	-40	-55	-70	Volts
Peak A-F Grid-to-Grid Voltage .....	320	300	300	Volts
Zero Sig. D-C Plate Current .....	26	28	30	Milliamperes
Max.-Sig. D-C Plate Current .....	210	160	130	Milliamperes
Load Resistance (Per tube) .....	1600	3125	5250	Ohms
Effective Load Res. (Plate-to-plate) ..	6400	12500	21000	Ohms
Max.-Sig. Driving Power (Approx.) ..	6	4.4	3.4	Watts
Max.-Sig. Power Output (Approx.) ..	90	100	106	Watts

#### As R-F Power Amplifier—Class B Telephony

*Carrier conditions per tube for use with a max. modulation factor of 1.0*

D-C PLATE VOLTAGE .....	1250 max.	Volts
D-C PLATE CURRENT .....	45 max.	Milliamperes
PLATE INPUT .....	50 max.	Watts
PLATE DISSIPATION .....	35 max.	Watts

#### TYPICAL OPERATION:

D-C Plate Voltage .....	750	1000	Volts
D-C Grid Voltage <sup>§</sup> .....	-40	-55	Volts
Peak R-F Grid Voltage .....	160	170	Volts
D-C Plate Current .....	45	42	Milliamperes
D-C Grid Current (Approx.) .....	2	2	Milliamperes
Driving Power (Approx.) <sup>†</sup> .....	3.6	3.3	Watts
Power Output (Approx.) .....	10	14	Watts

\* , §, †: see next page.

## As Plate-Modulated R-F Power Amplifier—Class C Telephony

Carrier conditions per tube for use with a max. modulation factor of 1.0

D-C PLATE VOLTAGE .....	1000	max.	Volts
D-C GRID VOLTAGE .....	-400	max.	Volts
D-C PLATE CURRENT .....	80	max.	Milliamperes
D-C GRID CURRENT .....	25	max.	Milliamperes
PLATE INPUT .....	80	max.	Watts
PLATE DISSIPATION .....	23	max.	Watts

## TYPICAL OPERATION:

D-C Plate Voltage .....	750	1000	Volts
D-C Grid Voltage§ .....	-150	-200	Volts
Peak R-F Grid Voltage .....	275	325	Volts
D-C Plate Current .....	70	70	Milliamperes
D-C Grid Current (Approx.) .....	15	15	Milliamperes
Grid Resistor .....	10000	13300	Ohms
Driving Power (Approx.) .....	3	4	Watts
Power Output (Approx.) .....	35	50	Watts

## As R-F Power Amplifier and Oscillator—Class C Telegraphy

Key-down conditions per tube without modulation††

D-C PLATE VOLTAGE .....	1250	max.	Volts
D-C GRID VOLTAGE .....	-400	max.	Volts
D-C PLATE CURRENT .....	80	max.	Milliamperes
D-C GRID CURRENT .....	25	max.	Milliamperes
PLATE INPUT .....	100	max.	Watts
PLATE DISSIPATION .....	35	max.	Watts

## TYPICAL OPERATION:

D-C Plate Voltage .....	750	1000	1250	Volts
D-C Grid Voltage§ .....	-100	-135	-175	Volts
Peak R-F Grid Voltage .....	225	260	300	Volts
D-C Plate Current .....	70	70	70	Milliamperes
D-C Grid Current (Approx.) .....	15	15	15	Milliamperes
Grid Resistor .....	6700	9000	11700	Ohms
Driving Power (Approx.) .....	2	3	4	Watts
Power Output (Approx.) .....	35	50	65	Watts

\* Averaged over any audio-frequency cycle of sine-wave form.

§ Grid voltages are given with respect to the mid-point of filament operated on a.c. If d.c. is used, each stated value of grid voltage should be decreased by 5 volts and the circuit returns made to the negative end of the filament.

† At crest of audio-frequency cycle with modulation factor of 1.0.

†† Modulation essentially negative may be used if the positive peak of the audio-frequency envelope does not exceed 115% of the carrier conditions.

## INSTALLATION AND APPLICATION

The base pins of the 800 fit the standard four-contact socket such as the RCA type UR-542A. The socket should be installed to hold the tube in a vertical position. The filament terminals are connected to the two large base pins; the grid and plate leads are brought out to separate metal caps at the top of the bulb.

The plate of the 800 shows no color at the maximum plate-dissipation rating for each class of service.

For high-frequency operation above 60 megacycles, see page 144.

For additional information, see chapters on INSTALLATION and APPLICATION.

AVERAGE PLATE CHARACTERISTICS

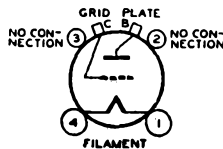
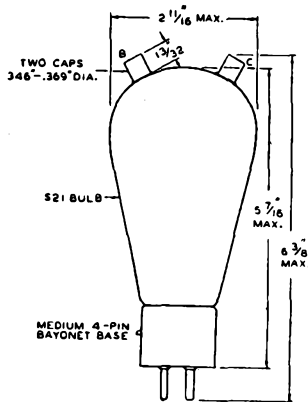
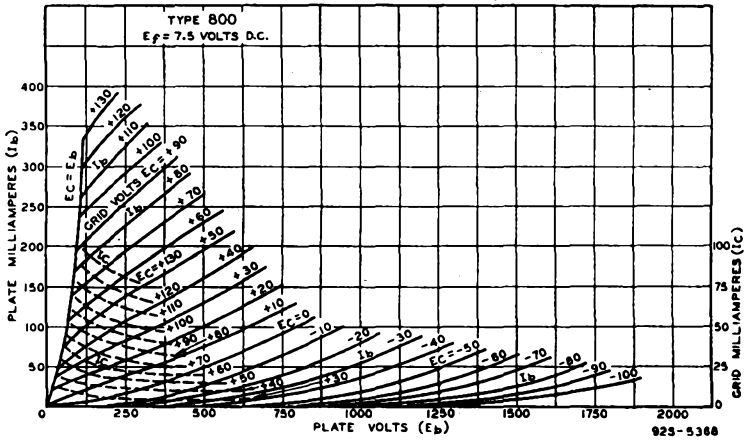

Top View of Socket Connections

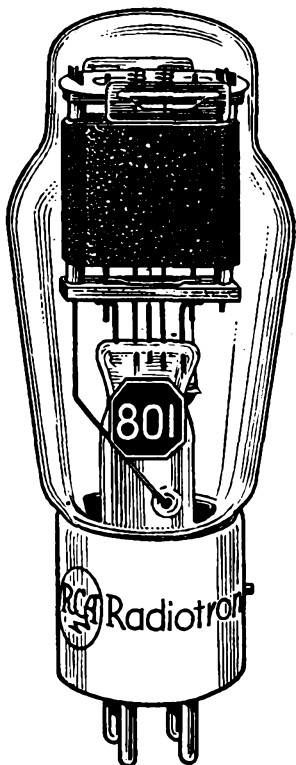

**RCA-801**

Rugged carbon-anode triode—20 watts plate dissipation—for those applications where good performance and reliability are prime requisites.

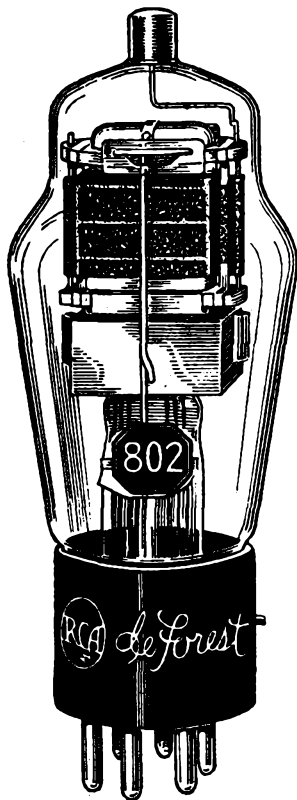

**RCA-802**

Pentode—easy to drive—no neutralization — a favorite for crystal-oscillator and buffer/doubler stages.

# RCA-801

## R-F and A-F Power Amplifier, Oscillator, Class B Modulator

RCA-801 is a three-electrode transmitting tube of the thoriated-tungsten filament type well suited for use as a radio-frequency amplifier and oscillator at high radio frequencies. It may also be used as an audio-frequency amplifier and modulator. The internal structure of this tube, together with its ceramic base, provides for operation at full rating at frequencies as high as 60 megacycles.

### CHARACTERISTICS

Filament Volts (a-c or d-c).....	7.5	Grid-Plate Capacitance .....	6 $\mu\text{f}$
Filament Amperes .....	1.25	Grid-Filament Capacitance .....	4.5 $\mu\text{f}$
Amplification Factor .....	8	Plate-Filament Capacitance .....	1.5 $\mu\text{f}$

### MAXIMUM RATINGS AND TYPICAL OPERATING CONDITIONS

#### As A-F Power Amplifier and Modulator—Class A

D-C PLATE VOLTAGE .....	600 max. Volts
PLATE DISSIPATION .....	20 max. Watts

#### TYPICAL OPERATION AND CHARACTERISTICS:

D-C Plate Voltage .....	425	500	600	Volts
D-C Grid Voltage <sup>§</sup> .....	-40	-45	-55	Volts
Peak A-F Grid Voltage .....	35	40	50	Volts
D-C Plate Current .....	18	24	30	Milliamperes
Plate Resistance .....	5000	4600	4300	Ohms
Transconductance .....	1600	1725	1840	Micromhos
Load Resistance .....	10200	8000	7800	Ohms
Cathode-Bias Resistor .....	2225	1875	1835	Ohms
Undistorted Power Output .....	1.6	2.3	3.8	Watts

#### As A-F Power Amplifier and Modulator—Class B

D-C PLATE VOLTAGE .....	600 max. Volts
MAX.-SIGNAL D-C PLATE CURRENT* .....	70 max. Milliamperes
MAX.-SIGNAL PLATE INPUT* .....	42 max. Watts
PLATE DISSIPATION* .....	20 max. Watts

#### TYPICAL OPERATION:

*Unless otherwise specified, values are for 2 tubes*

D-C Plate Voltage .....	400	500	600	Volts
D-C Grid Voltage <sup>§</sup> .....	-50	-60	-75	Volts
Peak A-F Grid-to-Grid Voltage .....	270	290	320	Volts
Zero-Sig. D-C Plate Current .....	8	8	8	Milliamperes
Max.-Sig. D-C Plate Current .....	130	130	130	Milliamperes
Load Resistance (Per tube) .....	1500	2000	2500	Ohms
Effective Load Res. (Plate-to-plate)...	6000	8000	10000	Ohms
Max.-Sig. Driving Power (Approx.)	3	3	3	Watts
Max.- Sig. Power Output (Approx.)	27	36	45	Watts

§, \*: see next page.



### As R-F Power Amplifier—Class B Telephony

Carrier conditions per tube for use with a max. modulation factor of 1.0

D-C PLATE VOLTAGE .....	600	max.	Volts
D-C PLATE CURRENT .....	50	max.	Milliamperes
PLATE INPUT .....	30	max.	Watts
PLATE DISSIPATION .....	20	max.	Watts

**TYPICAL OPERATION:**

D-C Plate Voltage .....	500	600	Volts
D-C Grid Voltage§ .....	-60	-75	Volts
Peak R-F Grid Voltage .....	85	90	Volts
D-C Plate Current .....	45	45	Milliamperes
D-C Grid Current (Approx.) .....	0.2	0.2	Milliampere
Driving Power (Approx.)† .....	2.2	2.3	Watts
Power Output (Approx.) .....	6	7.5	Watts

### As Plate-Modulated R-F Power Amplifier—Class C Telephony

Carrier conditions per tube for use with a max. modulation factor of 1.0

D-C PLATE VOLTAGE .....	500	max.	Volts
D-C GRID VOLTAGE .....	-200	max.	Volts
D-C PLATE CURRENT .....	60	max.	Milliamperes
D-C GRID CURRENT .....	15	max.	Milliamperes
PLATE INPUT .....	30	max.	Watts
PLATE DISSIPATION .....	13.5	max.	Watts

**TYPICAL OPERATION:**

D-C Plate Voltage .....	400	500	Volts
D-C Grid Voltage§ .....	-150	-190	Volts
Peak R-F Grid Voltage .....	260	300	Volts
D-C Plate Current .....	55	55	Milliamperes
D-C Grid Current (Approx.) .....	15	15	Milliamperes
Grid Resistor .....	10000	12700	Ohms
Driving Power (Approx.) .....	4	4.5	Watts
Power Output (Approx.) .....	14	18	Watts

### As R-F Power Amplifier and Oscillator—Class C Telegraphy

Key-down conditions per tube without modulation††

D-C PLATE VOLTAGE .....	600	max.	Volts
D-C GRID VOLTAGE .....	-200	max.	Volts
D-C PLATE CURRENT .....	70	max.	Milliamperes
D-C GRID CURRENT .....	15	max.	Milliamperes
PLATE INPUT .....	42	max.	Watts
PLATE DISSIPATION .....	20	max.	Watts

**TYPICAL OPERATION:**

D-C Plate Voltage .....	500	600	Volts
D-C Grid Voltage§ .....	-125	-150	Volts
Peak R-F Grid Voltage .....	235	260	Volts
D-C Plate Current .....	65	65	Milliamperes
D-C Grid Current (Approx.) .....	15	15	Milliamperes
Grid Resistor .....	8300	10000	Ohms
Driving Power (Approx.) .....	3.5	4	Watts
Power Output (Approx.) .....	20	25	Watts

\* Averaged over any audio-frequency cycle of sine-wave form.

§ Grid voltages are given with respect to the mid-point of filament operated on a.c. If d.c. is used, each stated value of grid voltage should be decreased by 5 volts and the circuit returns made to the negative end of the filament.

† At crest of audio-frequency cycle with modulation factor of 1.0.

†† Modulation essentially negative may be used if the positive peak of the audio-frequency envelope does not exceed 115% of the carrier conditions.

## INSTALLATION AND APPLICATION

The base pins of the RCA-801 fit the standard, four-contact socket, such as the RCA type UR-542A. The socket should be installed to hold the tube in a vertical position with the base down. If it is necessary to place the tube in a horizontal position, the socket should be mounted with the filament-pin openings one vertically above the other so that the plate will be in a vertical plane (on edge).

The plate of the 801 shows no color at the maximum plate-dissipation rating for each class of service.

When the 801 is used as a class A amplifier with resistance- or impedance-coupling in the input circuit, the d-c resistance in the grid circuit should not be made too high. A resistance value of 0.5 megohm for one 801 is the recommended maximum when cathode bias is used. Without cathode bias, the grid resistance should not exceed 100,000 ohms.

For high-frequency operation above 60 megacycles, see page 144.

For additional information, see chapters on INSTALLATION and APPLICATION.

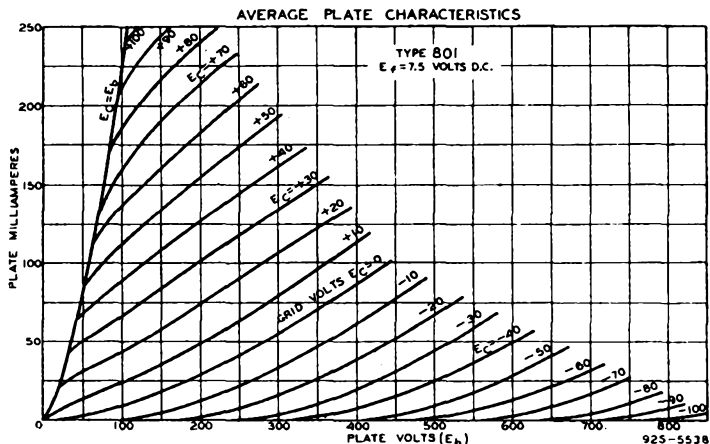

Top View of Socket Connections

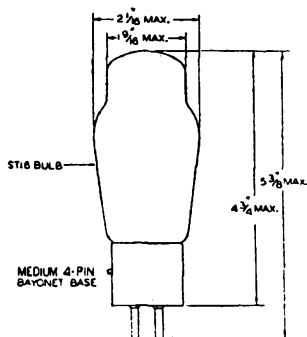
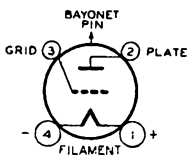

# RCA-802

## Power Amplifier Pentode

Illustrated on page 46

RCA-802 is a pentode transmitting tube of the heater-cathode type for use as an r-f amplifier, frequency multiplier, oscillator, and suppressor, grid-, or plate-modulated amplifier. The plate connection is brought out through a separate seal at the top of the bulb to maintain low grid-plate capacitance. Neutralization to prevent feedback is generally unnecessary in adequately shielded circuits. The suppressor and the special internal shield are connected to individual base pins. The 802 may be operated at maximum rated input at frequencies as high as 30 megacycles.

### CHARACTERISTICS

Heater Volts (a-c or d-c).....	6.3	Grid-Plate Capacitance (With	
Heater Amperes .....	0.9	external shielding) .....	0.15 max. $\mu\text{f}$
Transconductance (For plate current		Input Capacitance .....	12 $\mu\text{f}$
of 20 ma.) Micromhos .....	2250	Output Capacitance .....	8.5 $\mu\text{f}$

### MAXIMUM RATINGS AND TYPICAL OPERATING CONDITIONS

#### As R-F Power Amplifier Pentode—Class B Telephony

Carrier conditions per tube for use with a max. modulation factor of 1.0

D-C PLATE VOLTAGE .....	500 max.	Volts
D-C SUPPRESSOR VOLTAGE (Grid No. 3) .....	200 max.	Volts
D-C SCREEN VOLTAGE (Grid No. 2) .....	250 max.	Volts
D-C PLATE CURRENT .....	30 max.	Milliamperes
PLATE INPUT .....	15 max.	Watts
SUPPRESSOR INPUT .....	2 max.	Watts
SCREEN INPUT .....	4 max.	Watts
PLATE DISSIPATION .....	10 max.	Watts

#### TYPICAL OPERATION:

D-C Plate Voltage .....	400	500	Volts
Suppressor <sup>†</sup> .....	Connected to cathode at socket		
D-C Screen Voltage .....	150	200	Volts
D-C Grid Voltage (Grid No. 1) .....	-22	-28	Volts
Peak R-F Grid Voltage .....	35	32	Volts
Internal Shield .....	Connected to cathode at socket		
D-C Plate Current .....	25	25	Milliamperes
D-C Screen Current .....	6.5	7	Milliamperes
D-C Grid Current (Approx.) .....	1	0	Milliampere
Driving Power (Approx.) <sup>†</sup> .....	0.5	0.18	Watt
Power Output (Approx.) .....	2.75	3.5	Watts

#### As Suppressor-Modulated R-F Power Amplifier—Class C Telephony

Carrier conditions per tube for use with a max. modulation factor of 1.0

D-C PLATE VOLTAGE .....	500 max.	Volts
D-C SCREEN VOLTAGE (Grid No. 2) .....	200 max.	Volts
D-C GRID VOLTAGE (Grid No. 1) .....	-200 max.	Volts
D-C PLATE CURRENT .....	30 max.	Milliamperes
D-C GRID CURRENT .....	7.5 max.	Milliamperes
PLATE INPUT .....	15 max.	Watts
SCREEN INPUT .....	6 max.	Watts
PLATE DISSIPATION .....	10 max.	Watts

#### TYPICAL OPERATION:

D-C Plate Voltage .....	400	500	500	Volts
D-C Suppressor Voltage (Grid No. 3) .....	-40	-53	-45	Volts
D-C Grid Voltage .....	-85	-90	-90	Volts
Peak R-F Grid Voltage .....	125	125	125	Volts

†. †: see end of tabulation.

Peak A-F Suppressor Voltage .....	40	53	65	Volts
Internal Shield .....	Connected to cathode at socket			
D-C Plate Current .....	18	20	22	Milliamperes
D-C Screen Current .....	28	28	28	Milliamperes
D-C Grid Current (Approx.) .....	7.5	5	4.5	Milliamperes
Screen Resistor .....	9000	10700	10700	Ohms
Grid Resistor .....	11300	18000	20000	Ohms
Driving Power (Approx.) .....	0.9	0.6	0.5	Watt
Power Output (Approx.) .....	2	3	3.5	Watts

### As Grid-Modulated R-F Power Amplifier Pentode—Class C Telephony

Carrier conditions per tube for use with a max. modulation factor of 1.0

D-C PLATE VOLTAGE .....	500 max.	Volts
D-C SUPPRESSOR VOLTAGE (Grid No. 3).....	200 max.	Volts
D-C SCREEN VOLTAGE (Grid No. 2).....	250 max.	Volts
D-C GRID VOLTAGE (Grid No. 1).....	-200 max.	Volts
D-C PLATE CURRENT .....	30 max.	Milliamperes
PLATE INPUT .....	15 max.	Watts
SUPPRESSOR INPUT .....	2 max.	Watts
SCREEN INPUT .....	4 max.	Watts
PLATE DISSIPATION .....	10 max.	Watts

#### TYPICAL OPERATION:

D-C Plate Voltage .....	400	500	Volts
Suppressor <sup>†</sup> .....	Connected to cathode at socket		
D-C Screen Voltage .....	150	200	Volts
D-C Grid Voltage .....	-105	-130	Volts
Peak R-F Grid Voltage .....	125	145	Volts
Peak A-F Grid Voltage .....	40	50	Volts
Internal Shield .....	Connected to cathode at socket		
D-C Plate Current .....	25	25	Milliamperes
D-C Screen Current .....	7.5	8	Milliamperes
D-C Grid Current (Approx.) .....	2	1	Milliamperes
Driving Power (Approx.) <sup>†</sup> .....	1	0.8	Watt
Power Output (Approx.) .....	3	4	Watts

### As Plate-Modulated R-F Power Amplifier—Class C Telephony

Carrier conditions per tube for use with a max. modulation factor of 1.0

	Pentode Connection	Tetrode Connection	
D-C PLATE VOLTAGE .....	400 max.	400 max.	Volts
D-C SUPPRESSOR VOLTAGE (Grid No. 3) .....	200 max.	—	Volts
D-C SCREEN VOLTAGE*** .....	200 max.	200 max.	Volts
D-C GRID VOLTAGE (Grid No. 1).....	-200 max.	-200 max.	Volts
D-C PLATE CURRENT .....	40 max.	40 max.	Milliamperes
D-C GRID CURRENT .....	7.5 max.	7.5 max.	Milliamperes
PLATE INPUT .....	16 max.	16 max.	Watts
SUPPRESSOR INPUT .....	2 max.	—	Watts
SCREEN INPUT .....	4 max.	6 max.	Watts
PLATE DISSIPATION .....	6.7 max.	6.7 max.	Watts

#### TYPICAL OPERATION:

D-C Plate Voltage .....	400	400	Volts
D-C Suppressor Voltage .....	40	—	Volts
D-C Screen Voltage*** .....	195	85	Volts
D-C Grid Voltage .....	-40	-120	Volts
Peak R-F Grid Voltage .....	55	160	Volts
Internal Shield .....	Connected to cathode at socket		
D-C Plate Current .....	35	35	Milliamperes

†, ††, \*\*\*: see end of tabulation.

D-C Screen Current .....	17	21	Milliamperes
D-C Grid Current (Approx.) .....	1.5	6	Milliamperes
Screen Resistor .....	12000‡	15000**	Ohms
Grid Resistor .....	26700	20000	Ohms
Driving Power (Approx.) .....	0.1	0.9	Watt
Power Output (Approx.) .....	8	8	Watts

### As R-F Power Amplifier and Oscillator—Class C Telegraphy

Key-down conditions per tube without modulation††

	Pentode Connection	Tetrode Connection	
D-C PLATE VOLTAGE .....	500 max.	500 max.	Volts
D-C SUPP. VOLT. (Grid No. 3) .....	200 max.	—	Volts
D-C SCREEN VOLTAGE*** .....	250 max.	200 max.	Volts
D-C GRID VOLT. (Grid No. 1) .....	-200 max.	-200 max.	Volts
D-C PLATE CURRENT .....	60 max.	60 max.	Milliamperes
D-C GRID CURRENT .....	7.5 max.	7.5 max.	Milliamperes
PLATE INPUT .....	25 max.	25 max.	Watts
SUPPRESSOR INPUT .....	2 max.	—	Watts
SCREEN INPUT .....	6 max.	6 max.	Watts
PLATE DISSIPATION .....	10 max.	10 max.	Watts

**TYPICAL OPERATION:**

D-C Plate Voltage .....	500	500	400	500	Volts
D-C Suppressor Voltage .....	0	40	—	—	Volts
D-C Screen Voltage*** .....	200	250	100	100	Volts
D-C Grid Voltage .....	-100	-100	-60	-60	Volts
Peak R-F Grid Voltage .....	155	155	90	90	Volts
Internal Shield .....	Connected to cathode at socket				
D-C Plate Current .....	45	45	45	45	Milliamperes
D-C Screen Current .....	22	12	15	15	Milliamperes
D-C Grid Current (Approx.) .....	6	2	7	6	Milliamperes
Screen Resistor .....	13600	20800	20000	27000	Ohms
Grid Resistor .....	16200	50000	8600	10000	Ohms
Driving Power (Approx.).....	0.9	0.25	0.7	0.5	Watt
Power Output (Approx.).....	14	16	10	12	Watts

‡ Applying a positive voltage of not more than 40 volts to the suppressor gives slightly increased output.

† At crest of audio-frequency cycle with modulation factor of 1.0.

\*\* Connected to unmodulated plate-voltage supply.

\*\*\* For pentode connection, grid No. 2; for tetrode connection, grids No. 2 and No. 3 connected together.

‡ Connected to modulated plate-voltage supply.

†† Modulation essentially negative may be used if the positive peak of the audio-frequency envelope does not exceed 115% of the carrier conditions.

## INSTALLATION AND APPLICATION

The base pins of the 802 fit the 7-contact (0.855-inch pin-circle diameter) socket which may be mounted to hold the tube in any position.

When the heater is operated from a d-c source, the cathode circuit is tied to the negative heater supply lead. In circuits where the cathode is not directly connected to the heater, the potential difference between them should not exceed 100 volts.

The internal shield should be tied to a terminal operating at zero r-f and/or a-f potential. In most cases, this connection will be made to the cathode or suppressor terminal.

Adequate shielding and isolation of the input circuit and the output circuit are necessary if optimum results are to be obtained. If an external shield is employed with the 802, it should be designed to enclose the base end of the tube and extend up to a point level with the bottom of the internal shield.

Clearance between the glass bulb and external shield should be at least  $\frac{1}{8}$ ". The impedance between the screen and cathode must be kept as low as possible by the use of a by-pass condenser.

The plate of the 802 shows no color at the maximum plate-dissipation rating for each class of service. The screen should not be allowed to show more than a barely perceptible red color.

As a pentode or tetrode oscillator (crystal or self-excited), the 802 may be operated under the conditions shown for class C telegraph services. Because the internal shielding in this tube is unusually effective, it generally is necessary to introduce external feed-back in those circuits which depend on the control-grid-to-plate capacity for oscillation. This may be done by the use of a small condenser not larger than 2 to 3  $\mu\text{f}$  connected between control grid and plate.

For high-frequency operation above 30 megacycles, see page 144.

For additional information, see chapters on INSTALLATION and APPLICATION.

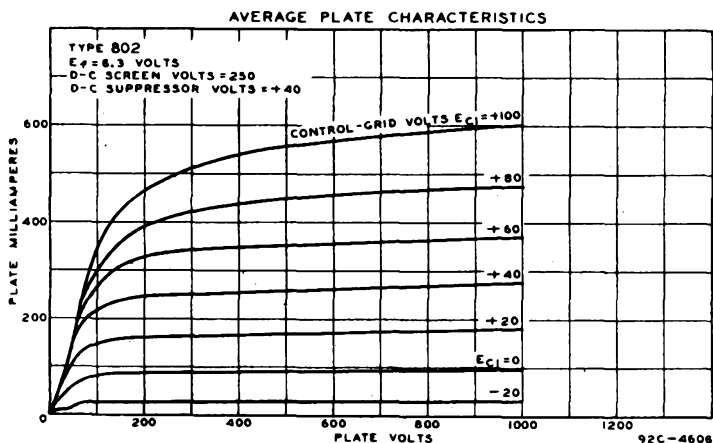

Top View of Socket Connections

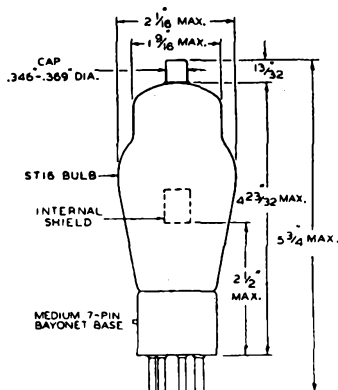
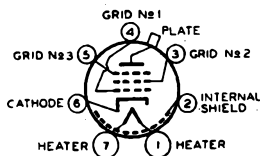

# RCA-803

## R-F Amplifier Pentode

Illustrated on front cover

RCA-803 is a pentode transmitting tube of the thoriated-tungsten filament type for use as an r-f amplifier, frequency multiplier, oscillator, and suppressor, grid-, or plate-modulated amplifier. The plate connection is brought out through a separate seal at the top of the bulb to insure excellent insulation and low grid-plate capacitance. In adequately shielded circuits, neutralization to prevent feedback is generally unnecessary. The suppressor is connected to its individual base pin. The 803 may be operated at maximum ratings in all classes of service at frequencies as high as 20 megacycles. The maximum rated plate dissipation of the tube is 125 watts. RCA-803 has a ceramic base.

### CHARACTERISTICS

Filament Volts (a-c or d-c) .....	10.0	Grid-Plate Capacitance (With external shielding) .....	0.15 max. $\mu\text{f}$
Filament Amperes .....	5	Input Capacitance .....	17.5 $\mu\text{f}$
Transconductance (For plate current of 62.5 ma.) Micromhos .....	4000	Output Capacitance .....	29 $\mu\text{f}$

### MAXIMUM RATINGS AND TYPICAL OPERATING CONDITIONS

#### As R-F Power Amplifier Pentode—Class B Telephony

Carrier conditions per tube for use with a max. modulation factor of 1.0

D-C PLATE VOLTAGE .....	2000 max. Volts
D-C SUPPRESSOR VOLTAGE (Grid No. 3).....	500 max. Volts
D-C SCREEN VOLTAGE (Grid No. 2).....	600 max. Volts
D-C PLATE CURRENT .....	160 max. Milliamperes
PLATE INPUT .....	180 max. Watts
SUPPRESSOR INPUT .....	10 max. Watts
SCREEN INPUT .....	20 max. Watts
PLATE DISSIPATION .....	125 max. Watts

#### TYPICAL OPERATION:

D-C Plate Voltage .....	1250	1500	2000	Volts
D-C Suppressor Voltage .....	40	40	40	Volts
D-C Screen Voltage .....	500	550	600	Volts
D-C Grid Voltage (Grid No. 1)§.....	-30	-35	-40	Volts
Peak R-F Grid Voltage .....	90	70	55	Volts
D-C Plate Current .....	130	110	80	Milliamperes
D-C Screen Current .....	33	30	20	Milliamperes
D-C Grid Current (Approx.) .....	8	5	3	Milliamperes
Driving Power (Approx.)† .....	4.5	3	1.5	Watts
Power Output (Approx.) .....	52	53	53	Watts

#### As Suppressor-Modulated R-F Power Amplifier—Class C Telephony

Carrier conditions per tube for use with a max. modulation factor of 1.0

D-C PLATE VOLTAGE .....	2000 max. Volts
D-C SCREEN VOLTAGE (Grid No 2).....	600 max. Volts
D-C GRID VOLTAGE (Grid No. 1).....	-500 max. Volts
D-C PLATE CURRENT .....	110 max. Milliamperes
D-C GRID CURRENT .....	50 max. Milliamperes
PLATE INPUT .....	180 max. Watts
SCREEN INPUT .....	30 max. Watts
PLATE DISSIPATION .....	125 max. Watts

§, †: see end of tabulation.

**TYPICAL OPERATION:**

D-C Plate Voltage .....	1250	1500	2000	Volts
D-C Supp. Volt. (Grid No. 3).....	-70	-90	-110	Volts
D-C Grid Voltage <sup>§</sup> .....	-110	-100	-100	Volts
Peak R-F Grid Voltage .....	200	190	170	Volts
Peak A-F Suppressor Voltage .....	110	130	150	Volts
D-C Plate Current .....	100	100	80	Milliamperes
D-C Screen Current .....	70	70	48	Milliamperes
D-C Grid Current (Approx.) .....	22	20	15	Milliamperes
Screen Resistor .....	13000	17000	35000	Ohms
Grid Resistor .....	5000	5000	7000	Ohms
Driving Power (Approx.) .....	4	3.5	2.5	Watts
Power Output (Approx.) .....	40	50	53	Watts

**As Grid-Modulated R-F Power Amplifier Pentode—Class C Telephony**

*Carrier conditions per tube for use with a max. modulation factor of 1.0*

D-C PLATE VOLTAGE .....	2000 max.	Volts
D-C SUPPRESSOR VOLTAGE (Grid No. 3).....	500 max.	Volts
D-C SCREEN VOLTAGE (Grid No. 2).....	600 max.	Volts
D-C GRID VOLTAGE (Grid No. 1).....	-500 max.	Volts
D-C PLATE CURRENT .....	160 max.	Milliamperes
PLATE INPUT .....	180 max.	Watts
SUPPRESSOR INPUT .....	10 max.	Watts
SCREEN INPUT .....	20 max.	Watts
PLATE DISSIPATION .....	125 max.	Watts

**TYPICAL OPERATION:**

D-C Plate Voltage .....	1250	1500	2000	Volts
D-C Suppressor Voltage .....	40	40	40	Volts
D-C Screen Voltage .....	500	550	600	Volts
D-C Grid Voltage <sup>§</sup> .....	-100	-90	-80	Volts
Peak R-F Grid Voltage .....	160	130	100	Volts
Peak A-F Grid Voltage .....	75	65	50	Volts
D-C Plate Current .....	130	110	80	Milliamperes
D-C Screen Current .....	30	25	20	Milliamperes
D-C Grid Current (Approx.) .....	8	6	4	Milliamperes
Driving Power (Approx.) <sup>†</sup> .....	4	3	2	Watts
Power Output (Approx.) .....	52	53	53	Watts

**As Plate-Modulated R-F Power Amplifier—Class C Telephony**

*Carrier conditions per tube for use with a max. modulation factor of 1.0*

	Pentode Connection	Tetrode Connection	
D-C PLATE VOLTAGE .....	1600 max.	1600 max.	Volts
D-C SUPP. VOLT. (Grid No 3)	500 max.	—	Volts
D-C SCREEN VOLTAGE*** .....	500 max.	500 max.	Volts
D-C GRID VOLT. (Grid No. 1)	-500 max.	-500 max.	Volts
D-C PLATE CURRENT .....	160 max.	160 max.	Milliamperes
D-C GRID CURRENT .....	50 max.	50 max.	Milliamperes
PLATE INPUT .....	250 max.	250 max.	Watts
SUPPRESSOR INPUT .....	10 max.	—	Watts
SCREEN INPUT .....	20 max.	30 max.	Watts
PLATE DISSIPATION .....	85 max.	85 max.	Watts

**TYPICAL OPERATION:**

D-C Plate Voltage .....	1250	1600	1250	1600	Volts
D-C Suppressor Voltage .....	100	100	—	—	Volts
D-C Screen Voltage .....	400	500	130	130	Volts
D-C Grid Voltage <sup>§</sup> .....	-80	-80	-180	-180	Volts

§, †, \*\*\*: see end of tabulation.



Peak R-F Grid Voltage .....	180	180	305	320	Volts
D-C Plate Current .....	150	150	150	150	Milliamperes
D-C Screen Current .....	55	55	75	75	Milliamperes
D-C Grid Current (Approx.) .....	20	20	45	45	Milliamperes
Screen Resistor .....	16000‡	20000‡	15000**	20000**	Ohms
Grid Resistor .....	4000	4000	4000	4000	Ohms
Driving Power (Approx.) .....	4	4	15	15	Watts
Power Output (Approx.) .....	125	155	125	155	Watts

### As R-F Power Amplifier and Oscillator—Class C Telegraphy

Key-down conditions per tube without modulation††

	Pentode Connection	Tetrode Connection	
D-C PLATE VOLTAGE .....	2000 max.	2000 max.	Volts
D-C SUPP. VOLT. (Grid No. 3) .....	500 max.	—	Volts
D-C SCREEN VOLTAGE*** .....	600 max.	600 max.	Volts
D-C GRID VOLT. (Grid No. 1) .....	-500 max.	-500 max.	Volts
D-C PLATE CURRENT .....	175 max.	175 max.	Milliamperes
D-C GRID CURRENT .....	50 max.	50 max.	Milliamperes
PLATE INPUT .....	350 max.	350 max.	Watts
SUPPRESSOR INPUT .....	10 max.	—	Watts
SCREEN INPUT .....	30 max.	30 max.	Watts
PLATE DISSIPATION .....	125 max.	125 max.	Watts

**TYPICAL OPERATION:**

D-C Plate Voltage .....	1500	2000	1500	2000	Volts
D-C Suppressor Voltage .....	40	40	—	—	Volts
D-C Screen Voltage .....	500	500	150	150	Volts
D-C Grid Voltage† .....	-90	-90	-90	-90	Volts
Peak R-F Grid Voltage .....	175	175	190	190	Volts
D-C Plate Current .....	160	160	160	160	Milliamperes
D-C Screen Current .....	45	45	15	15	Milliamperes
D-C Grid Current (Approx.) .....	12	12	27	26	Milliamperes
Screen Resistor .....	Not recommended				
Grid Resistor .....	7500	7500	3500	3500	Ohms
Driving Power (Approx.) .....	2	2	4.4	4.4	Watts
Power Output (Approx.) .....	160	210	160	210	Watts

‡ Grid voltages are given with respect to the mid-point of filament operated on a.c. If d.c. is used, each stated value of grid voltage should be decreased by 7 volts and the circuit returns made to the negative end of the filament.

† At crest of audio-frequency cycle with modulation factor of 1.0.

\*\*\* For pentode connection, Grid No. 2 is screen; for tetrode connection, grids No. 2 and 3 connected together.

‡ Connected to modulated plate supply.

\*\* Connected to unmodulated plate-voltage supply.

†† Modulation essentially negative may be used if the positive peak of the audio-frequency envelope does not exceed 115% of the carrier conditions.

## INSTALLATION AND APPLICATION

The base pins of the 803 fit the special 5-contact socket which should be mounted to hold the tube in a vertical position with the filament base either up or down. The plate connection is made to the cap at the top of the bulb.

Adequate shielding and isolation of the input circuit and the output circuit are necessary if optimum results are to be obtained. If an external shield is employed with the 803, it should be designed to enclose the base end of the tube and extend up to a position 1/4" above the circular shield disc located at the bottom of the plate. Clearance between the glass bulb and external shield should be at least 1/8". The impedance between the screen and filament must be kept as low as

possible by the use of a by-pass condenser. When screen voltage is obtained from a series resistance, the screen by-pass condenser should have a voltage breakdown rating high enough to withstand the full plate voltage of the tube.

The plate of the 803 shows only a barely perceptible red color at the maximum plate-dissipation rating for each class of service. The screen should never be allowed to show more than a dull red color.

For high-frequency operation above 20 megacycles, see page 144.

For additional information, see chapters on INSTALLATION and APPLICATION.

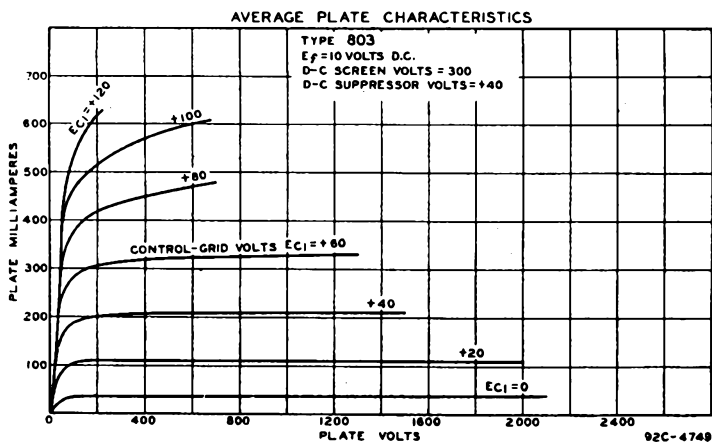

Top View of Socket Connections

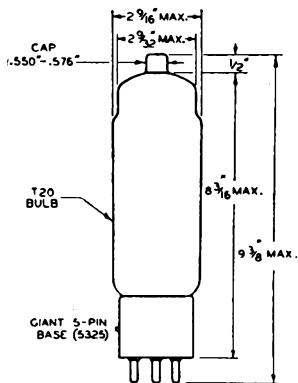
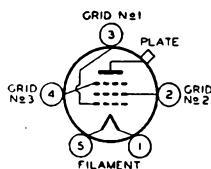

## R-F Power Amplifier Pentode

RCA-804 is a pentode transmitting tube of the thoriated-tungsten filament type for use as an r-f amplifier, frequency multiplier, oscillator, and suppressor-, grid-, or plate-modulated amplifier. The plate connection is brought out through a separate seal at the top of the bulb to insure excellent insulation and low grid-plate capacitance. In adequately shielded circuits, neutralization to prevent feedback is generally unnecessary. The suppressor is connected to its individual base pin. RCA-804 may be operated at maximum ratings in all classes of service at frequencies as high as 15 megacycles. The 804 has a ceramic base.

### CHARACTERISTICS

Filament Volts (a-c or d-c).....	7.5	Grid-Plate Capacitance (With external shielding) .....	0.01 max. $\mu\text{f}$
Filament Amperes .....	3	Input Capacitance .....	16 $\mu\text{f}$
Transconductance (For plate current of 32 ma.) Micromhos.....	3250	Output Capacitance .....	14.5 $\mu\text{f}$

### MAXIMUM RATINGS AND TYPICAL OPERATING CONDITIONS

#### As R-F Power Amplifier Pentode—Class B Telephony

*Carrier conditions per tube for use with a max. modulation factor of 1.0*

D-C PLATE VOLTAGE .....	1250 max.	Volts
D-C SUPPRESSOR VOLTAGE (Grid No. 3).....	200 max.	Volts
D-C SCREEN VOLTAGE (Grid No. 2).....	300 max.	Volts
D-C PLATE CURRENT .....	50 max.	Milliamperes
PLATE INPUT .....	60 max.	Watts
SUPPRESSOR INPUT .....	5 max.	Watts
SCREEN INPUT .....	10 max.	Watts
PLATE DISSIPATION .....	40 max.	Watts

#### TYPICAL OPERATION:

D-C Plate Voltage .....	1000	1000	1250	Volts
D-C Suppressor Voltage .....	0	45	45	Volts
D-C Screen Voltage .....	300	300	300	Volts
D-C Grid Voltage (Grid No. 1)§.....	-20	-20	-20	Volts
Peak R-F Grid Voltage .....	30	30	27	Volts
D-C Plate Current .....	45	45	45	Milliamperes
D-C Screen Current .....	12	11.5	11	Milliamperes
D-C Grid Current (Approx.) .....	1	1	1	Milliampere
Driving Power (Approx.)† .....	0.35	0.3	0.25	Watt
Power Output (Approx.) .....	11	12	16	Watts

#### As Suppressor-Modulated R-F Power Amplifier—Class C Telephony

*Carrier conditions per tube for use with a max. modulation factor of 1.0*

D-C PLATE VOLTAGE .....	1250 max.	Volts
D-C SCREEN VOLTAGE (Grid No. 2).....	300 max.	Volts
D-C GRID VOLTAGE (Grid No. 1) .....	-300 max.	Volts
D-C PLATE CURRENT .....	50 max.	Milliamperes
D-C GRID CURRENT .....	15 max.	Milliamperes
PLATE INPUT .....	60 max.	Watts
SCREEN INPUT .....	15 max.	Watts
PLATE DISSIPATION .....	40 max.	Watts

§, †: see end of tabulation.

TYPICAL OPERATION:

D-C Plate Voltage .....	1000	1250	Volts
D-C Suppressor Voltage (Grid No. 3).....	-35	-50	Volts
D-C Grid Voltage‡ .....	-100	-100	Volts
Peak R-F Grid Voltage .....	140	140	Volts
Peak A-F Suppressor Voltage .....	60	70	Volts
D-C Plate Current .....	45	48	Milliamperes
D-C Screen Current .....	33.5	35.5	Milliamperes
D-C Grid Current (Approx.) .....	5.5	7	Milliamperes
Screen Resistor .....	21000	27000	Ohms
Grid Resistor .....	18000	15000	Ohms
Driving Power (Approx.) .....	0.7	0.85	Watt
Power Output (Approx.) .....	16	21	Watts

As Grid-Modulated R-F Power Amplifier Pentode—Class C Telephony

Carrier conditions per tube for use with a max. modulation factor of 1.0

D-C PLATE VOLTAGE .....	1250 max.	Volts
D-C SUPPRESSOR VOLTAGE (Grid No. 3).....	200 max.	Volts
D-C SCREEN VOLTAGE (Grid No. 2).....	300 max.	Volts
D-C GRID VOLTAGE (Grid No. 1).....	-300 max.	Volts
D-C PLATE CURRENT .....	50 max.	Milliamperes
PLATE INPUT .....	60 max.	Watts
SUPPRESSOR INPUT .....	5 max.	Watts
SCREEN INPUT .....	10 max.	Watts
PLATE DISSIPATION .....	40 max.	Watts

TYPICAL OPERATION:

D-C Plate Voltage .....	1000	1000	1250	Volts
D-C Suppressor Voltage .....	0	45	45	Volts
D-C Screen Voltage .....	300	300	300	Volts
D-C Grid Voltage‡ .....	-115	-115	-115	Volts
Peak R-F Grid Voltage .....	140	135	135	Volts
Peak A-F Grid Voltage .....	35	35	35	Volts
D-C Plate Current .....	45	45	45	Milliamperes
D-C Screen Current .....	15	11	11	Milliamperes
D-C Grid Current (Approx.) .....	2	2	2	Milliamperes
Driving Power (Approx.)† .....	1.1	0.85	0.85	Watts
Power Output (Approx.) .....	14	16	21	Watts

As Plate-Modulated R-F Power Amplifier—Class C Telephony

Carrier conditions per tube for use with a max. modulation factor of 1.0

	Pentode Connection	Tetrode Connection	
D-C PLATE VOLTAGE .....	1000 max.	1000 max.	Volts
D-C SUPPRESSOR VOLTAGE (Grid No. 3) .....	200 max.	—	Volts
D-C SCREEN VOLTAGE*** .....	300 max.	200 max.	Volts
D-C GRID VOLTAGE (Grid No. 1).....	-300 max.	-300 max.	Volts
D-C PLATE CURRENT .....	80 max.	80 max.	Milliamperes
D-C GRID CURRENT .....	15 max.	15 max.	Milliamperes
PLATE INPUT .....	80 max.	80 max.	Watts
SUPPRESSOR INPUT .....	5 max.	—	Watts
SCREEN INPUT .....	10 max.	15 max.	Watts
PLATE DISSIPATION .....	27 max.	27 max.	Watts

TYPICAL OPERATION:

D-C Plate Voltage .....	1000	1000	Volts
D-C Suppressor Voltage .....	50	—	Volts
D-C Screen Voltage .....	220	155	Volts
D-C Grid Voltage‡ .....	-90	-80	Volts
Peak R-F Grid Voltage .....	130	145	Volts

‡, †, \*\*\*, ‡: see end of tabulation.

D-C Plate Current .....	75	75	Milliamperes
D-C Screen Current .....	21	28	Milliamperes
D-C Grid Current (Approx.) .....	6	8	Milliamperes
Screen Resistor .....	37000‡	30000**	Ohms
Grid Resistor .....	15000	10000	Ohms
Driving Power (Approx.) .....	0.65	1.1	Watts
Power Output (Approx.) .....	50	50	Watts

### As R-F Power Amplifier and Oscillator—Class C Telegraphy

Key-down conditions per tube without modulation††

	Pentode Connection	Tetrode Connection	
D-C PLATE VOLTAGE .....	1250 max.	1250 max.	Volts
D-C SUPPRESSOR VOLTAGE (Grid No. 3) .....	200 max.	—	Volts
D-C SCREEN VOLTAGE*** .....	300 max.	200 max.	Volts
D-C GRID VOLTAGE (Grid No. 1) .....	-300 max.	-300 max.	Volts
D-C PLATE CURRENT .....	95 max.	95 max.	Milliamperes
D-C GRID CURRENT .....	15 max.	15 max.	Milliamperes
PLATE INPUT .....	120 max.	120 max.	Watts
SUPPRESSOR INPUT .....	5 max.	—	Watts
SCREEN INPUT .....	15 max.	15 max.	Watts
PLATE DISSIPATION .....	40 max.	40 max.	Watts

**TYPICAL OPERATION:**

D-C Plate Voltage .....	1250	1250	1250	Volts
D-C Suppressor Voltage .....	0	45	—	Volts
D-C Screen Voltage .....	300	300	180	Volts
D-C Grid Voltage‡ .....	-100	-100	-100	Volts
Peak R-F Grid Voltage .....	145	150	160	Volts
D-C Plate Current .....	80	92	92	Milliamperes
D-C Screen Current .....	33	27	23	Milliamperes
D-C Grid Current (Approx.)... ..	7	7	8	Milliamperes
Screen Resistor .....	Not recommended			
Grid Resistor .....	14300	14300	12500	Ohms
Driving Power (Approx.) .....	0.9	0.95	1.2	Watts
Power Output (Approx.) .....	64	80	80	Watts

‡ Grid voltages are given with respect to the mid-point of filament operated on a.c. If d.c. is used, each stated value of grid voltage should be decreased by 5 volts and the circuit returns made to the negative end of the filament.

† At crest of audio-frequency cycle with modulation factor of 1.0.

\*\*\* For pentode connection, grid No. 2 is screen; for tetrode connection, grids No. 2 and 3 are connected together.

‡ Connected to modulated supply.

\*\* Connected to unmodulated plate-voltage supply.

†† Modulation essentially negative may be used if the positive peak of the audio-frequency envelope does not exceed 115% of the carrier conditions.

## INSTALLATION AND APPLICATION

The base pins of the 804 fit the standard 5-contact socket which should be installed to hold the tube in a vertical position with the base down. If it is necessary to mount the tube in a horizontal position, the socket should be mounted with the filament-pin openings one vertically above the other so that the plate will be in a vertical plane (on edge). The plate connection of the 804 is made to the cap at the top of the bulb.

Adequate shielding and isolation of the input and the output circuit are necessary if optimum results are to be obtained. If an external shield is employed with the 804, it should be designed to enclose the base end of the tube and extend up to a position 1/4 inch above the lowest edge of the internal shielding.

Clearance between the glass bulb and external shield should be at least  $\frac{1}{8}$ ". The impedance between the screen and filament must be kept as low as possible by the use of a by-pass condenser. When screen voltage is obtained from a series resistance, the screen by-pass condenser should have a voltage breakdown rating high enough to withstand the full plate voltage of the tube.

The plate of the 804 shows no color when the tube is operated at its maximum plate-dissipation rating for each class of service. The screen should not be allowed to show more than a barely perceptible red color.

For high-frequency operation above 15 megacycles, see page 144.

For additional information, see chapters on INSTALLATION and APPLICATION.

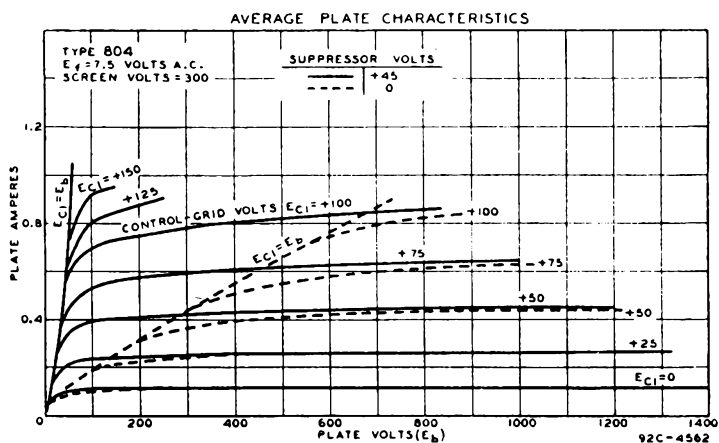

Top View of Socket Connections

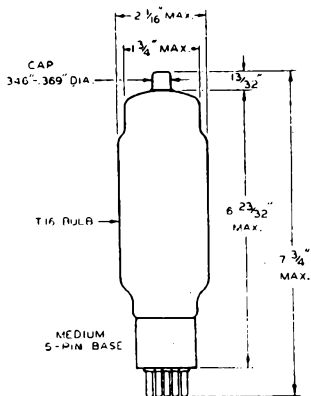
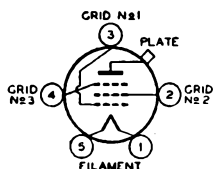

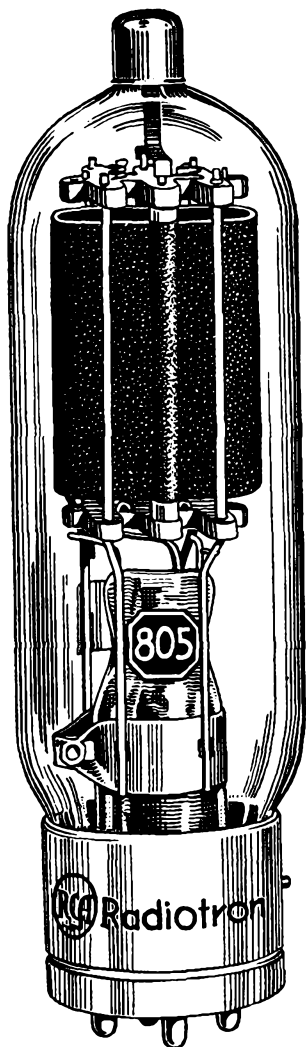

RCA-805

A husky, carbon-anode triode—excellent zero-bias, class B modulator—125 watts plate dissipation—full input to 30 megacycles.

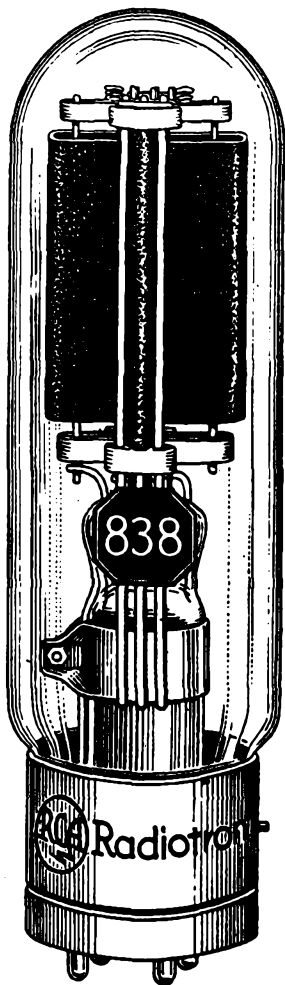

RCA-838

Carbon-anode triode particularly suited for zero-bias class B modulator applications requiring up to 260 watts of audio power.

The 203-A, 211, and 845—all of the popular so-called 50-watt class—are similar in appearance to the 838. All now have 100-watt plate dissipation rating.

# RCA-805

## R-F Power Amplifier, Oscillator, Class B Modulator

RCA-805 is a high- $\mu$ , three-electrode transmitting tube of the thoriated-tungsten filament type for use as a radio-frequency amplifier, oscillator, and class B audio-frequency amplifier. The plate connection is brought out through a separate seal at the top of the bulb to insure good insulation. As an r-f amplifier or oscillator the 805 may be operated at maximum ratings for frequencies as high as 30 megacycles. The grid is designed so that the amplification of the tube varies with the amplitude of the input signal. This feature facilitates the design of class B amplifiers to give high output with low distortion. The maximum plate dissipation of the RCA-805 is 125 watts for class C telegraph and class B services.

### CHARACTERISTICS

Filament Volts (a-c or d-c).....	10.0	Grid-Plate Capacitance .....	6.5 $\mu\mu\text{f}$
Filament Amperes .....	3.25	Grid-Filament Capacitance .....	8.5 $\mu\mu\text{f}$
		Plate-Filament Capacitance .....	10.5 $\mu\mu\text{f}$

### MAXIMUM RATINGS AND TYPICAL OPERATING CONDITIONS

#### As A-F Power Amplifier and Modulator—Class B

D-C PLATE VOLTAGE .....	1500 max.	Volts
MAX.-SIGNAL D-C PLATE CURRENT* .....	210 max.	Milliamperes
MAX.-SIGNAL PLATE INPUT* .....	315 max.	Watts
PLATE DISSIPATION* .....	125 max.	Watts

#### TYPICAL OPERATION:

*Unless otherwise specified, values are for 2 tubes*

D-C Plate Voltage .....	1250	1500	Volts
D-C Grid Voltage <sup>§</sup> .....	0	-16	Volts
Peak A-F Grid-to-Grid Voltage .....	235	280	Volts
Zero-Sig. D-C Plate Current .....	148	84	Milliamperes
Max.-Sig. D-C Plate Current .....	400	400	Milliamperes
Load Resistance (Per tube) .....	1675	2050	Ohms
Effective Load Res. (Plate-to-plate) .....	6700	8200	Ohms
Max.-Sig. Driving Power (Approx.) .....	6	7	Watts
Max-Sig. Power Output (Approx.) .....	300 <sup>†</sup>	370**	Watts

#### As R-F Power Amplifier—Class B Telephony

*Carrier conditions per tube for use with a max. modulation factor of 1.0*

D-C PLATE VOLTAGE .....	1500 max.	Volts
D-C PLATE CURRENT .....	150 max.	Milliamperes
PLATE INPUT .....	185 max.	Watts
PLATE DISSIPATION .....	125 max.	Watts

#### TYPICAL OPERATION:

D-C Plate Voltage .....	1250	1500	Volts
D-C Grid Voltage <sup>§</sup> .....	0	-10	Volts
Peak R-F Grid Voltage .....	75	70	Volts
D-C Plate Current .....	135	115	Milliamperes
D-C Grid Current (Approx.) .....	15	15	Milliamperes
Driving Power (Approx.) <sup>†</sup> .....	11	7.5	Watts
Power Output (Approx.) .....	55	57.5	Watts

• §, †, ‡, \*\*: see next page.



## As Plate-Modulated R-F Power Amplifier—Class C Telephony

Carrier conditions per tube for use with a max. modulation factor of 1.0

D-C PLATE VOLTAGE .....	1250	max.	Volts
D-C GRID VOLTAGE .....	-500	max.	Volts
D-C PLATE CURRENT .....	175	max.	Milliamperes
D-C GRID CURRENT .....	70	max.	Milliamperes
PLATE INPUT .....	220	max.	Watts
PLATE DISSIPATION .....	85	max.	Watts

## TYPICAL OPERATION:

D-C Plate Voltage .....	1000	1250	Volts
D-C Grid Voltage <sup>§</sup> .....	-155	-160	Volts
Peak R-F Grid Voltage .....	295	300	Volts
D-C Plate Current .....	160	160	Milliamperes
D-C Grid Current (Approx.) .....	60	60	Milliamperes
Grid Resistor .....	2600	2700	Ohms
Driving Power (Approx.) .....	16	16	Watts
Power Output (Approx.) .....	110	140	Watts

## As R-F Power Amplifier and Oscillator—Class C Telegraphy

Key-down conditions per tube without modulation<sup>††</sup>

D-C PLATE VOLTAGE .....	1500	max.	Volts
D-C GRID VOLTAGE .....	-500	max.	Volts
D-C PLATE CURRENT .....	210	max.	Milliamperes
D-C GRID CURRENT .....	70	max.	Milliamperes
PLATE INPUT .....	315	max.	Watts
PLATE DISSIPATION .....	125	max.	Watts

## TYPICAL OPERATION:

D-C Plate Voltage .....	1000	1250	1500	Volts
D-C Grid Voltage <sup>§</sup> .....	-95	-100	-105	Volts
Peak R-F Grid Voltage .....	225	230	235	Volts
D-C Plate Current .....	200	200	200	Milliamperes
D-C Grid Current (Approx.) .....	40	40	40	Milliamperes
Grid Resistor .....	2400	2500	2600	Ohms
Driving Power (Approx.) .....	8.5	8.5	8.5	Watts
Power Output (Approx.) .....	130	170	215	Watts

\* Averaged over any audio-frequency cycle of sine-wave form.

§ Grid voltages are given with respect to the mid-point of filament operated on a.c.

‡ Approximately 4% harmonic distortion.

\*\* Approximately 3% harmonic distortion.

† At crest of audio-frequency cycle with modulation factor of 1.0.

†† Modulation essentially negative may be used if the positive peak of the audio-frequency envelope does not exceed 115% of the carrier conditions.

## INSTALLATION AND APPLICATION

The base pins of the 805 fit the standard transmitting 4-contact socket, such as the RCA type UT-541A. The socket should be mounted to hold the tube in a vertical position with the base down. The plate lead is brought out to the cap at the top of the bulb.

The plate of the 805 shows only a barely perceptible red color when operated at the maximum plate-dissipation rating for each class of service.

When the 805 is operated as a class B audio-frequency amplifier and it is desirable to keep the audio-frequency distortion below 3%, the use of a small amount of grid-bias voltage at reduced plate voltage is advantageous. Typical

operating conditions are approximately the same as those for the 1250-volt condition. The exceptions are: grid-bias voltage, -14 volts; peak a-f grid-to-grid voltage, 250 volts; and zero-signal d-c plate current, 60 milliamperes (two tubes).

In class C telegraph service when the tube is operated at a plate voltage of 1250 volts or less, grid-leak bias is particularly useful. If the grid excitation is accidentally removed, the high plate resistance of the tube serves to protect it from overheating due to accidental overloads.

For high-frequency operation above 30 megacycles, see page 144.

For additional information, see chapters on INSTALLATION and APPLICATION.

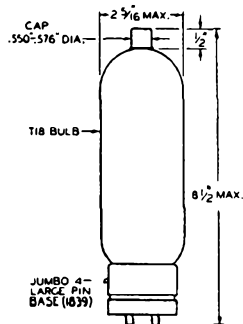
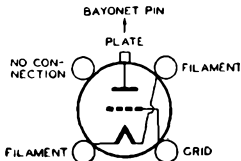
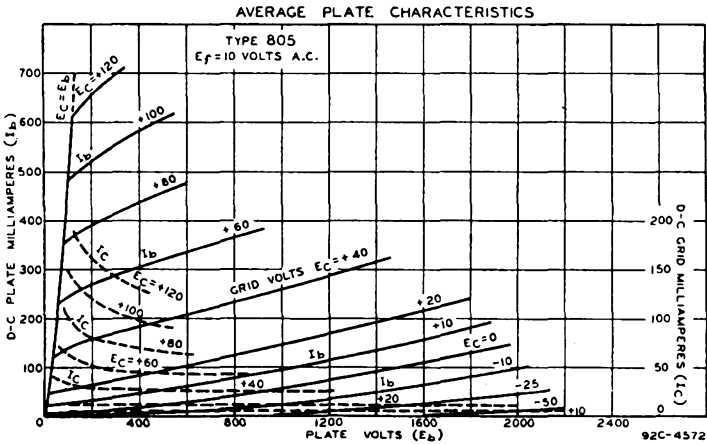

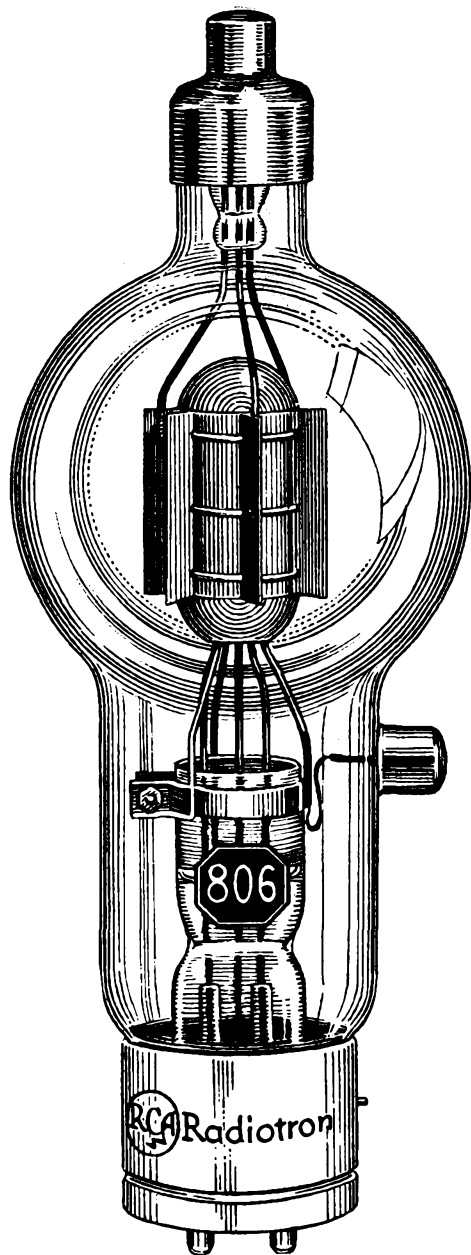

### RCA-806

A heavy-duty, tantalum-plate triode  
—two can take a kilowatt input on  
either 'phone or C.W.

# RCA-806

## R-F Power Amplifier, Oscillator, Class B Modulator

RCA-806 is a three-electrode transmitting tube for use as a radio-frequency amplifier, oscillator and class B audio-frequency amplifier. The plate connection is brought out through a separate seal at the top of the bulb; the grid connection is brought out through a separate seal in the lower part of the bulb near the filament base. This design insures excellent insulation and low interelectrode capacitances. In r-f service, the 806 may be operated at maximum ratings at frequencies as high as 30 megacycles. The maximum plate dissipation is 150 watts for class C telegraph and class B services.

### CHARACTERISTICS

Filament Volts (a-c or d-c).....	5.0	Grid-Plate Capacitance .....	3.4 $\mu\text{f}$
Filament Amperes .....	10	Grid-Filament Capacitance .....	6.1 $\mu\text{f}$
Amplification Factor .....	12.6	Plate-Filament Capacitance .....	1.1 $\mu\text{f}$

### MAXIMUM RATINGS AND TYPICAL OPERATING CONDITIONS

#### As A-F Power Amplifier and Modulator—Class B

D-C PLATE VOLTAGE .....	3000 max.	Volts
MAX.-SIGNAL D-C PLATE CURRENT* .....	200 max.	Milliamperes
MAX.-SIGNAL PLATE INPUT* .....	500 max.	Watts
PLATE DISSIPATION* .....	150 max.	Watts

#### TYPICAL OPERATION:

*Unless otherwise specified, values are for 2 tubes*

D-C Plate Voltage .....	2000	3000	Volts
D-C Grid Voltage <sup>§</sup> .....	-150	-240	Volts
Peak A-F Grid-to-Grid Voltage .....	680	810	Volts
Zero-Sig. D-C Plate Current .....	20	20	Milliamperes
Max.-Sig. D-C Plate Current .....	390	330	Milliamperes
Load Resistance (Per tube) .....	2875	5375	Ohms
Effective Load Res. (Plate-to-plate) .....	11500	21500	Ohms
Max.-Sig. Driving Power (Approx.) .....	14	10	Watts
Max.-Sig. Power Output (Approx.) .....	500	660	Watts

#### As R-F Power Amplifier—Class B Telephony

*Carrier conditions per tube for use with a max. modulation factor of 1.0*

D-C PLATE VOLTAGE .....	3000 max.	Volts
D-C PLATE CURRENT .....	150 max.	Milliamperes
PLATE INPUT .....	225 max.	Watts
PLATE DISSIPATION .....	150 max.	Watts

#### TYPICAL OPERATION:

D-C Plate Voltage .....	2000	3000	Volts
D-C Grid Voltage <sup>§</sup> .....	-150	-240	Volts
Peak R-F Grid Voltage .....	180	200	Volts
D-C Plate Current .....	110	70	Milliamperes
D-C Grid Current (Approx.) .....	1	0	Milliampere
Driving Power (Approx.) <sup>†</sup> .....	8	5	Watts
Power Output (Approx.) .....	70	70	Watts

\* , § , †: see next page.

## As Plate-Modulated R-F Power Amplifier—Class C Telephony

Carrier conditions per tube for use with a max. modulation factor of 1.0

D-C PLATE VOLTAGE .....	2500	max.	Volts
D-C GRID VOLTAGE .....	-1000	max.	Volts
D-C PLATE CURRENT .....	200	max.	Milliamperes
D-C GRID CURRENT .....	50	max.	Milliamperes
PLATE INPUT .....	500	max.	Watts
PLATE DISSIPATION .....	110	max.	Watts

## TYPICAL OPERATION:

D-C Plate Voltage .....	2000	2500	Volts
D-C Grid Voltage <sup>§</sup> .....	-500	-600	Volts
Peak R-F Grid Voltage .....	790	890	Volts
D-C Plate Current .....	195	195	Milliamperes
D-C Grid Current (Approx.) .....	40	40	Milliamperes
Grid Resistor .....	12500	15000	Ohms
Driving Power (Approx.) .....	28	32	Watts
Power Output (Approx.) .....	300	390	Watts

## As R-F Power Amplifier and Oscillator—Class C Telegraphy

Key-down conditions per tube without modulation<sup>††</sup>

D-C PLATE VOLTAGE .....	3000	max.	Volts
D-C GRID VOLTAGE .....	-1000	max.	Volts
D-C PLATE CURRENT .....	200	max.	Milliamperes
D-C GRID CURRENT .....	50	max.	Milliamperes
PLATE INPUT .....	600	max.	Watts
PLATE DISSIPATION .....	150	max.	Watts

## TYPICAL OPERATION:

D-C Plate Voltage .....	2000	2500	3000	Volts
D-C Grid Voltage <sup>§</sup> .....	-400	-500	-600	Volts
Peak R-F Grid Voltage .....	640	755	870	Volts
D-C Plate Current .....	195	195	195	Milliamperes
D-C Grid Current (Approx.) .....	25	25	25	Milliamperes
Grid Resistor .....	16000	20000	24000	Ohms
Driving Power (Approx.) .....	15	17	20	Watts
Power Output (Approx.) .....	280	370	450	Watts

\* Averaged over any audio-frequency cycle of sine-wave form.

§ Grid voltages are given with respect to the mid-point of filament operated on a.c. If d.c. is used, each stated value of grid voltage should be decreased by 3.5 volts and the circuit returns connected to the negative end of the filament.

† At crest of audio-frequency cycle with modulation factor of 1.0.

†† Modulation essentially negative may be used if the positive peak of the audio-frequency envelope does not exceed 115% of the carrier conditions.

## INSTALLATION AND APPLICATION

The base pins of the 806 fit the standard transmitting 4-contact socket, such as the RCA type UT-541A. The socket should be mounted to hold the tube in a vertical position with the base down.

The bulb becomes very hot during continuous operation so that free circulation of air should be provided. Forced cooling is required for continuous key-down conditions in class C telegraph service and is recommended for all services at frequencies of 30 Mc or higher. Forced cooling may be accomplished by means of an electric fan which directs air against the middle and upper sections of the bulb.

The plate of the 806 shows an orange-red color at the maximum plate-dissipation rating for each class of service.

For high-frequency operation above 30 megacycles, see page 144.

For additional information, see chapters on INSTALLATION and APPLICATION.

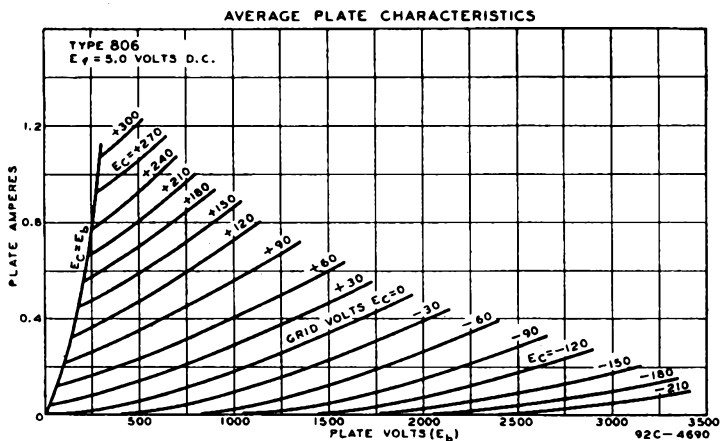

**Top View of Socket Connections**

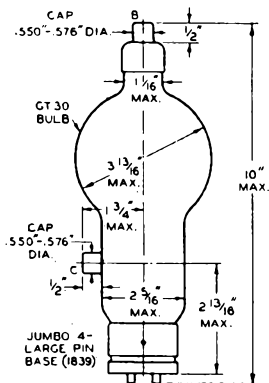
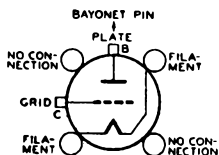

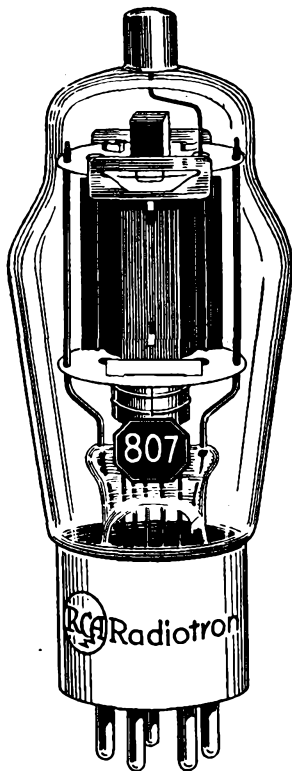

**RCA-807**

Beam power amplifier for all r-f applications — minimum driving power requirements—large output —neutralization usually unnecessary —a popular choice.

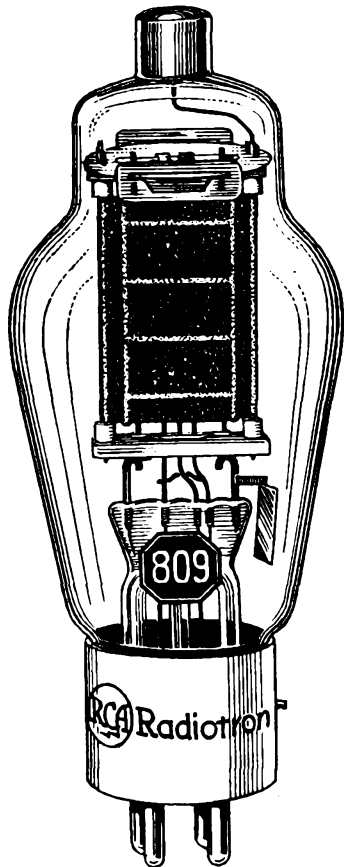

**RCA-809**

A high- $\mu$  triode which features high efficiency, excellent high-frequency performance, and economy —75 watts maximum input—a justly popular amateur tube.

# RCA-807

## Transmitting Beam Power Amplifier

RCA-807 is a heater-cathode type of transmitting tube incorporating new design principles involving the use of directed electron beams. Features resulting from the use of these principles in the 807 are that the screen does not absorb appreciable power and that efficient suppressor action is supplied by space-charge effects produced between the screen and the plate. The resultant high power sensitivity makes this tube especially suited for use as an r-f or a-f amplifier, frequency multiplier, oscillator and plate-modulated amplifier. The plate connection is brought out through a separate seal at the top of the bulb to maintain low grid-plate capacitance. In r-f applications the 807 may be operated at maximum ratings in all classes of service at frequencies as high as 60 megacycles. In class AB audio service two tubes of this type are capable of delivering an output of approximately 80 watts. RCA-807 has a ceramic base.

### CHARACTERISTICS

Heater Volts (a-c or d-c) .....	6.3	Grid-Plate Capacitance (With external shielding) .....	0.2 max. $\mu\text{mf}$
Heater Amperes .....	0.9	Input Capacitance .....	11 $\mu\text{mf}$
Transconductance (For plate current of 72 ma.) Micromhos, approx.....	6000	Output Capacitance .....	7 $\mu\text{mf}$

### MAXIMUM RATINGS AND TYPICAL OPERATING CONDITIONS

#### As Push-Pull Amplifier—Class AB<sub>2</sub><sup>§</sup> (Fixed bias)

D-C PLATE VOLTAGE .....	600 max. Volts
D-C SCREEN VOLTAGE (Grid No. 2).....	300 max. Volts
MAX.-SIGNAL D-C PLATE CURRENT* .....	120 max. Milliamperes
MAX.-SIGNAL PLATE INPUT* .....	60 max. Watts
SCREEN INPUT* .....	3.5 max. Watts
PLATE DISSIPATION* .....	25 max. Watts

#### TYPICAL OPERATION:

Unless otherwise specified, values are for 2 tubes

D-C Plate Voltage .....	400	500	600	Volts
D-C Screen Voltage .....	300	300	300	Volts
D-C Grid Voltage (Grid No. 1).....	-25	-25	-30	Volts
Peak A-F Grid-to-Grid Voltage .....	80	80	80	Volts
Zero-Signal D-C Plate Current .....	100	100	60	Milliamperes
Max.-Signal D-C Plate Current .....	230	230	200	Milliamperes
Max.-Signal D-C Screen Current .....	10	10	10	Milliamperes
Load Resistance (Per tube) .....	950	1165	1665	Ohms
Load Resistance (Plate-to-Plate) .....	3800	4660	6660	Ohms
Max.-Signal Driving Power† .....	0.35	0.6	0.4	Watt
Max.-Signal Power Output** .....	60	75	80	Watts

#### As R-F Power Amplifier—Class B Telephony

Carrier conditions per tube for use with a max. modulation factor of 1.0

D-C PLATE VOLTAGE .....	600 max. Volts
D-C SCREEN VOLTAGE (Grid No. 2).....	300 max. Volts
D-C PLATE CURRENT .....	80 max. Milliamperes
PLATE INPUT .....	37.5 max. Watts
SCREEN INPUT .....	2.5 max. Watts
PLATE DISSIPATION .....	25 max. Watts

§, \*, †, \*\*: see end of tabulation.



**TYPICAL OPERATION:**

D-C Plate Voltage .....	400	500	600	Volts
D-C Screen Voltage .....	250	250	250	Volts
D-C Grid Voltage (Grid No. 1).....	-25	-25	-25	Volts
Peak R-F Grid Voltage .....	30	30	20	Volts
D-C Plate Current .....	75	75	62.5	Milliamperes
D-C Screen Current .....	4	4	3	Milliamperes
D-C Grid Current (Approx.) .....	0	0	0	Milliampere
Driving Power (Approx.)*** .....	0.25	0.25	0.2	Watt
Power Output (Approx.) .....	9	12.5	12.5	Watts

**As Plate-Modulated R-F Power Amplifier—Class C Telephony**

*Carrier conditions per tube for use with a max. modulation factor of 1.0*

D-C PLATE VOLTAGE .....	475	max.	Volts
D-C SCREEN VOLTAGE (Grid No. 2).....	300	max.	Volts
D-C GRID VOLTAGE (Grid No. 1).....	-200	max.	Volts
D-C PLATE CURRENT .....	83	max.	Milliamperes
D-C GRID CURRENT .....	5	max.	Milliamperes
PLATE INPUT .....	40	max.	Watts
SCREEN INPUT .....	2.5	max.	Watts
PLATE DISSIPATION .....	16.5	max.	Watts

**TYPICAL OPERATION:**

D-C Plate Voltage .....	325	400	475	Volts
D-C Screen Voltage .....	225	225	225	Volts
D-C Grid Voltage .....	-45	-50	-50	Volts
Peak R-F Grid Voltage .....	70	70	70	Volts
D-C Plate Current .....	80	80	83	Milliamperes
D-C Screen Current .....	9	9	9	Milliamperes
D-C Grid Current (Approx.) .....	3	2	2	Milliamperes
Screen Resistor <sup>‡</sup> .....	10000	16000	25000	Ohms
Grid Resistor .....	5000	10000	10000	Ohms
Driving Power (Approx.) .....	0.2	0.13	0.13	Watt
Power Output (Approx.) .....	15	19	24	Watts

**As R-F Power Amplifier and Oscillator—Class C Telegraphy**

*Key-down conditions per tube without modulation††*

D-C PLATE VOLTAGE .....	600	max.	Volts
D-C SCREEN VOLTAGE (Grid No. 2) .....	300	max.	Volts
D-C GRID VOLTAGE (Grid No. 1) .....	-200	max.	Volts
D-C PLATE CURRENT .....	100	max.	Milliamperes
D-C GRID CURRENT .....	5	max.	Milliamperes
PLATE INPUT .....	60	max.	Watts
SCREEN INPUT .....	3.5	max.	Watts
PLATE DISSIPATION .....	25	max.	Watts

**TYPICAL OPERATION:**

D-C Plate Voltage .....	400	500	600	Volts
D-C Screen Voltage .....	250	250	250	Volts
D-C Grid Voltage .....	-50	-50	-50	Volts
Peak R-F Grid Voltage .....	80	80	80	Volts
D-C Plate Current .....	95	95	100	Milliamperes
D-C Screen Current .....	9	9	9	Milliamperes
D-C Grid Current (Approx.) .....	2.5	2	3	Milliamperes
Screen Resistor .....	17000	28000	39000	Ohms
Grid Resistor .....	20000	25000	16700	Ohms
Driving Power (Approx.) .....	0.18	0.14	0.22	Watt
Power Output (Approx.) .....	25	30	37.5	Watts

\*\*\*, ‡, ††: see next page.

§ Subscript (2) indicates that grid current flows during a part of input cycle.

\* Averaged over any audio-frequency cycle of sine-wave form.

† Driver stage should be capable of supplying the grids of the class AB stage with the specified peak values at low distortion. The effective resistance per grid circuit of the class AB stage should be kept below 500 ohms and the effective impedance at the highest desired response frequency should not exceed 700 ohms.

\*\* With zero-impedance driver and perfect regulation, plate-circuit distortion does not exceed 2%. In practice, plate-voltage regulation, screen-voltage regulation, and grid-bias regulation, should be not greater than 5%, 4%, and 3%, respectively.

\*\*\* At crest of audio-frequency cycle with modulation factor of 1.0.

‡ Connected to modulated plate-voltage supply.

†† Modulation essentially negative may be used if the positive peak of the audio-frequency envelope does not exceed 115% of the carrier conditions.

## INSTALLATION AND APPLICATION

The base pins of the RCA-807 fit the standard 5-contact socket which may be installed to hold the tube in any position.

The heater voltage should not fluctuate so that it ever exceeds 7.0 volts. In circuits where the cathode is not directly connected to the heater, the potential difference between them should not exceed 100 volts.

The plate of the 807 shows no color at the maximum plate-dissipation ratings for each class of service. The screen should never be allowed to show color.

For high-frequency operation above 60 megacycles, see page 144.

For additional information, see chapters on INSTALLATION and APPLICATION.

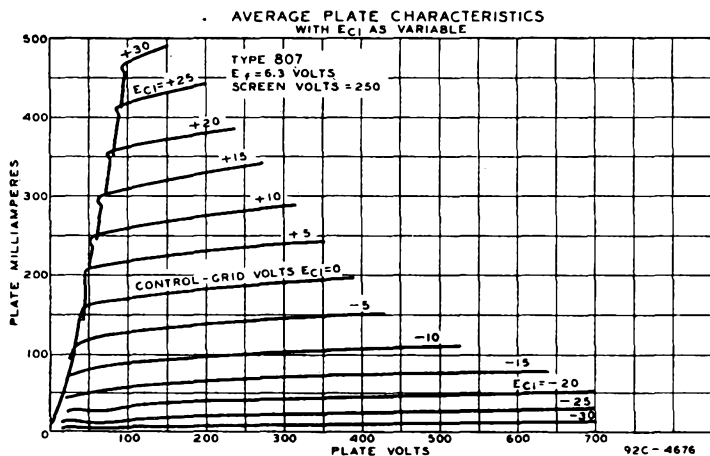

Top View of Socket Connections

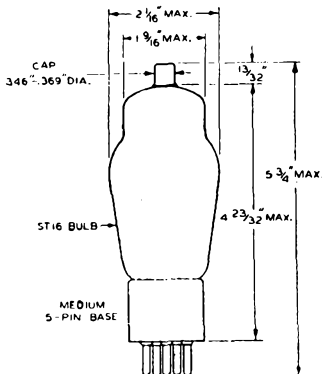
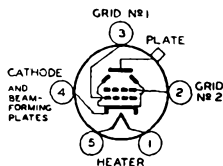

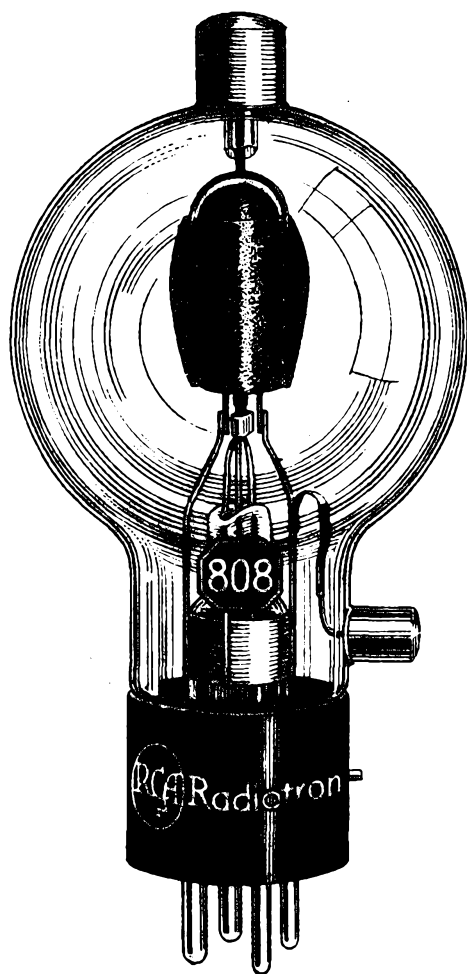

### RCA-808

Medium-power, tantalum-plate triode—easy to drive—high efficiency—high  $\mu$ —the outstanding type for 100-watt modulated, 150-watt unmodulated stages.

# RCA-808

## R-F Power Amplifier, Oscillator, Class B Modulator

RCA-808 is a three-electrode high- $\mu$ , transmitting tube of the thoriated-tungsten filament type for use as a radio-frequency amplifier, oscillator and class B audio-frequency amplifier. The plate connection is brought out through a separate seal at the top of the bulb; the grid connection is brought out through a separate seal in the lower part of the bulb near the filament base. This design insures good insulation and low inter-electrode capacitances. In r-f service, the 808 may be operated at maximum ratings at frequencies as high as 30 megacycles. The maximum plate dissipation is 50 watts for class C telegraph and class B services.

### CHARACTERISTICS

Filament Volts (a-c or d-c).....	7.5	Grid-Plate Capacitance .....	2.8 $\mu\mu\text{f}$
Filament Amperes .....	4	Grid-Filament Capacitance .....	5.3 $\mu\mu\text{f}$
Amplification Factor .....	47	Plate-Filament Capacitance .....	0.15 $\mu\mu\text{f}$

### MAXIMUM RATINGS AND TYPICAL OPERATING CONDITIONS

#### As A-F Power Amplifier and Modulator—Class B

D-C PLATE VOLTAGE .....	1500	max.	Volts
MAX.-SIGNAL D-C PLATE CURRENT* .....	150	max.	Milliamperes
MAX.-SIGNAL PLATE INPUT* .....	150	max.	Watts
PLATE DISSIPATION* .....	50	max.	Watts

#### TYPICAL OPERATION:

*Unless otherwise specified, values are for 2 tubes*

D-C Plate Voltage .....	1250	1500	Volts
D-C Grid Voltage <sup>§</sup> .....	-15	-25	Volts
Peak A-F Grid-to-Grid Voltage .....	240	220	Volts
Zero-Sig. D-C Plate Current .....	40	30	Milliamperes
Max.-Sig. D-C Plate Current .....	230	190	Milliamperes
Load Resistance (Per tube) .....	3175	4575	Ohms
Effective Load Res. (Plate-to-plate) .....	12700	18300	Ohms
Max.-Sig. Driving Power (Approx.) .....	7.8	4.8	Watts
Max.-Sig. Power Output (Approx.) .....	190	185	Watts

#### As R-F Power Amplifier—Class B Telephony

*Carrier conditions per tube for use with a max. modulation factor of 1.0*

D-C PLATE VOLTAGE .....	1500	max.	Volts
D-C PLATE CURRENT .....	75	max.	Milliamperes
PLATE INPUT .....	75	max.	Watts
PLATE DISSIPATION .....	50	max.	Watts

#### TYPICAL OPERATION:

D-C Plate Voltage .....	1250	1500	Volts
D-C Grid Voltage <sup>§</sup> .....	-30	-35	Volts
Peak R-F Grid Voltage .....	65	60	Volts
D-C Plate Current .....	55	45	Milliamperes
D-C Grid Current (Approx.) .....	1	1	Milliamperes
Driving Power (Approx.) <sup>†</sup> .....	3	2	Watts
Power Output (Approx.) .....	22	22	Watts

\*. §. †: see next page.

## As Plate-Modulated R-F Power Amplifier—Class C Telephony

Carrier conditions per tube for use with a max. modulation factor of 1.0

D-C PLATE VOLTAGE .....	1250	max.	Volts
D-C GRID VOLTAGE .....	-400	max.	Volts
D-C PLATE CURRENT .....	125	max.	Milliamperes
D-C GRID CURRENT .....	35	max.	Milliamperes
PLATE INPUT .....	135	max.	Watts
PLATE DISSIPATION .....	35	max.	Watts

## TYPICAL OPERATION:

D-C Plate Voltage .....	1000	1250	Volts
D-C Grid Voltage <sup>§</sup> .....	-210	-225	Volts
Peak R-F Grid Voltage .....	360	360	Volts
D-C Plate Current .....	120	100	Milliamperes
D-C Grid Current (Approx.) .....	35	32	Milliamperes
Grid Resistor .....	6000	7000	Ohms
Driving Power (Approx.) .....	11.5	10.5	Watts
Power Output (Approx.) .....	85	105	Watts

## As R-F Power Amplifier and Oscillator—Class C Telegraphy

Key-down conditions per tube without modulation††

D-C PLATE VOLTAGE .....	1500	max.	Volts
D-C GRID VOLTAGE .....	-400	max.	Volts
D-C PLATE CURRENT .....	150	max.	Milliamperes
D-C GRID CURRENT .....	35	max.	Milliamperes
PLATE INPUT .....	200	max.	Watts
PLATE DISSIPATION .....	50	max.	Watts

## TYPICAL OPERATION:

D-C Plate Voltage .....	1250	1500	Volts
D-C Grid Voltage <sup>§</sup> .....	-150	-200	Volts
Peak R-F Grid Voltage .....	300	350	Volts
D-C Plate Current .....	135	125	Milliamperes
D-C Grid Current (Approx.) .....	30	30	Milliamperes
Grid Resistor .....	5000	6670	Ohms
Driving Power (Approx.) .....	8	9.5	Watts
Power Output (Approx.) .....	120	140	Watts

\* Averaged over any audio-frequency cycle of sine-wave form.

§ Grid voltages are given with respect to the mid-point of filament operated on a.c. If d.c. is used, each stated value of grid voltage should be decreased by 5 volts and the circuit returns made to the negative end of the filament.

† At crest of audio-frequency cycle with modulation factor of 1.0.

†† Modulation essentially negative may be used if the positive peak of the audio-frequency envelope does not exceed 115% of the carrier conditions.

## INSTALLATION AND APPLICATION

The base pins of the RCA-808 fit the standard 4-contact socket, such as the RCA type UR-542A. The socket should be installed so that the tube will operate in a vertical position with the base down.

The plate of the 808 shows an orange-red color at the maximum plate dissipation rating for each class of service.

The grid-leak form of bias is particularly useful in class C Telegraph Service when the 808 is operated at a plate voltage of 1000 volts or less. If the grid excitation is accidentally removed, the high plate resistance of the tube serves to protect it from overheating due to accidental overloads.

For high-frequency operation above 30 megacycles, see page 144.

For additional information, see chapters on INSTALLATION and APPLICATION.

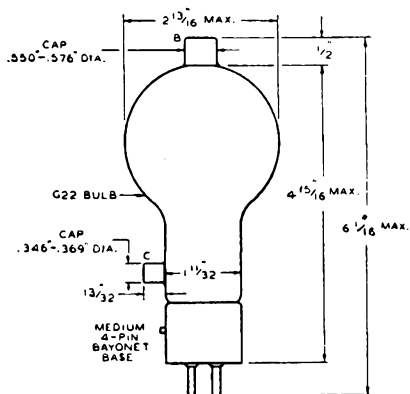
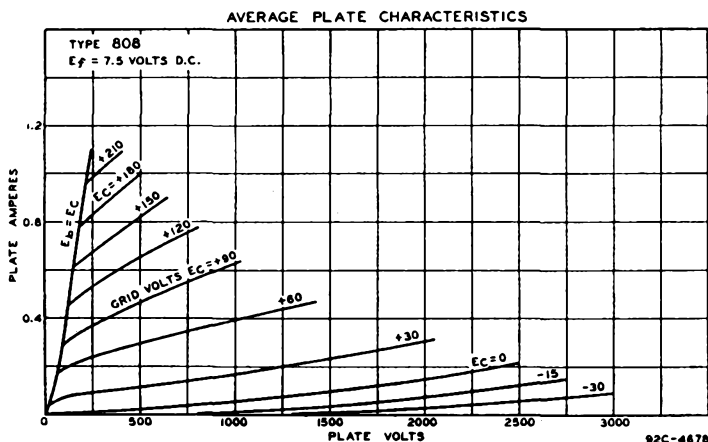

Top View of Socket Connections

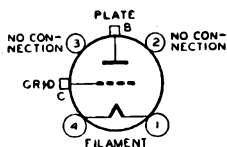

# RCA-809

## R-F Power Amplifier, Oscillator, Class B Modulator

Illustrated on page 70

RCA-809 is a three-electrode, high-mu, transmitting tube of the thoriated-tungsten filament type for use as a radio-frequency amplifier, oscillator, or class B modulator. Because of its high perveance, the 809 can be operated at high plate efficiency with low driving power. The plate connection is brought out through a separate seal at the top of the bulb to provide good insulation. The internal structure of the 809 permits operation at maximum ratings at frequencies as high as 60 megacycles. The maximum plate dissipation is 25 watts for class C telegraph and class B services. RCA-809 has a ceramic base.

### TENTATIVE CHARACTERISTICS AND RATINGS

Filament Volts (a-c or d-c).....	6.3	Grid-Plate Capacitance .....	6.7 $\mu\text{f}$
Filament Amperes .....	2.5	Grid-Filament Capacitance .....	5.7 $\mu\text{f}$
Amplification Factor .....	50	Plate-Filament Capacitance .....	0.9 $\mu\text{f}$

### MAXIMUM RATINGS AND TYPICAL OPERATING CONDITIONS

#### As A-F Power Amplifier and Modulator—Class B

D-C PLATE VOLTAGE .....	750	max. Volts
MAX.-SIGNAL D-C PLATE CURRENT* .....	100	max. Milliamperes
MAX.-SIGNAL PLATE INPUT* .....	75	max. Watts
PLATE DISSIPATION* .....	25	max. Watts

#### TYPICAL OPERATION:

*Unless otherwise specified, values are for 2 tubes*

D-C Plate Voltage .....	500	750	Volts
D-C Grid Voltage <sup>§</sup> .....	0	-5	Volts
Peak A-F Grid-to-Grid Voltage .....	135	140	Volts
Zero-Sig. D-C Plate Current .....	40	35	Milliamperes
Max.-Sig. D-C Plate Current .....	200	200	Milliamperes
Load Resistance (Per tube) .....	1300	2100	Ohms
Effective Load Res. (Plate-to-plate) .....	5200	8400	Ohms
Max.-Sig. Driving Power (Approx.) .....	2.4	2.4	Watts
Max.-Sig. Power Output (Approx.) .....	60	100	Watts

#### As R-F Power Amplifier—Class B Telephony

*Carrier conditions per tube for use with a max. modulation factor of 1.0*

D-C PLATE VOLTAGE .....	750	max. Volts
D-C PLATE CURRENT .....	50	max. Milliamperes
PLATE INPUT .....	37.5	max. Watts
PLATE DISSIPATION .....	25	max. Watts

#### TYPICAL OPERATION:

D-C Plate Voltage .....	500	750	Volts
D-C Grid Voltage <sup>§</sup> .....	-5	-10	Volts
Peak R-F Grid Voltage .....	35	40	Volts
D-C Plate Current .....	50	50	Milliamperes
D-C Grid Current (Approx.) .....	6	5	Milliamperes
Driving Power (Approx.) <sup>†</sup> .....	1.4	1.5	Watts
Power Output (Approx.) .....	7.5	12.5	Watts

\* , § , †: see next page.

### As Plate-Modulated R-F Power Amplifier—Class C Telephony

Carrier conditions per tube for use with a max. modulation factor of 1.0

D-C PLATE VOLTAGE .....	600	max.	Volts
D-C GRID VOLTAGE .....	-200	max.	Volts
D-C PLATE CURRENT .....	83	max.	Milliamperes
D-C GRID CURRENT .....	35	max.	Milliamperes
PLATE INPUT .....	50	max.	Watts
PLATE DISSIPATION .....	17.5	max.	Watts

**TYPICAL OPERATION:**

D-C Plate Voltage .....	500	600	Volts
D-C Grid Voltage .....	-160	-160	Volts
Peak R-F Grid Voltage .....	250	250	Volts
D-C Plate Current .....	83	83	Milliamperes
D-C Grid Current (Approx.) .....	32	32	Milliamperes
Grid Resistor .....	5000	5000	Ohms
Driving Power (Approx.) .....	7.2	7.2	Watts
Power Output (Approx.) .....	30	38	Watts

### As R-F Power Amplifier and Oscillator—Class C Telegraphy

Key-down conditions per tube without modulation††

D-C PLATE VOLTAGE .....	750	max.	Volts
D-C GRID VOLTAGE .....	-200	max.	Volts
D-C PLATE CURRENT .....	100	max.	Milliamperes
D-C GRID CURRENT .....	35	max.	Milliamperes
PLATE INPUT .....	75	max.	Watts
PLATE DISSIPATION .....	25	max.	Watts

**TYPICAL OPERATION:**

D-C Plate Voltage .....	500	750	Volts
D-C Grid Voltage .....	-50	-60	Volts
Peak R-F Grid Voltage .....	135	140	Volts
D-C Plate Current .....	100	100	Milliamperes
D-C Grid Current (Approx.) .....	20	20	Milliamperes
Grid Resistor .....	2500	3000	Ohms
Driving Power (Approx.) .....	2.5	2.5	Watts
Power Output (Approx.) .....	35	55	Watts

\* Averaged over any audio-frequency cycle of sine-wave form.

§ Grid voltages are given with respect to the mid-point of filament operated on a.c. If d.c. is used, each stated value of grid voltage should be decreased by 4.5 volts and the circuit returns made to the negative end of the filament.

† At crest of audio-frequency cycle with modulation factor of 1.0.

†† Modulation essentially negative may be used if the positive peak of the audio-frequency envelope does not exceed 115% of the carrier conditions.

## INSTALLATION AND APPLICATION

The base pins of the RCA-809 fit the standard 4-contact socket, such as the RCA type UR-542A. The socket should be installed so that the tube will operate in a vertical position with the base down. If it is necessary to place the tube in a horizontal position, the socket should be mounted with the filament-pin openings one vertically above the other so that the plate will be in a vertical plane (on edge).

The plate of the 809 shows no color at the maximum plate-dissipation rating for each class of service.



The grid-leak method of supplying bias is particularly suited for use with the 809 in class C telegraph service. If the grid excitation is accidentally removed, the high plate resistance of the tube serves to protect the tube from overheating due to accidental overloads.

For high-frequency operation above 60 megacycles, see page 144.

For additional information, see chapters on INSTALLATION and APPLICATION.

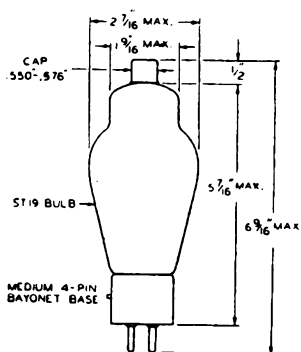
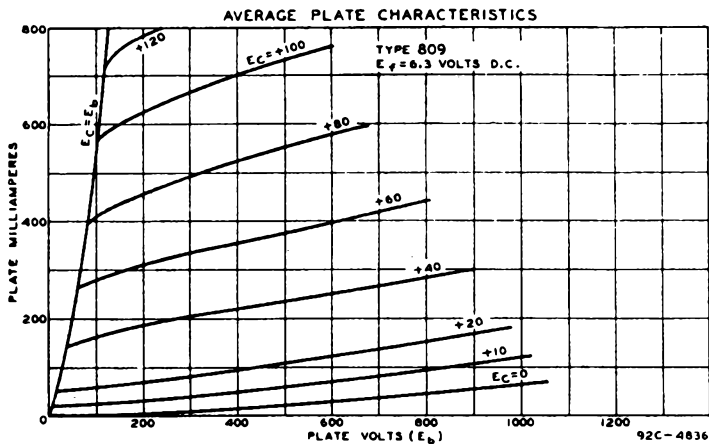

**Top View of Socket Connections**

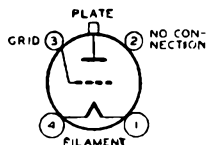

# RCA-814

## Transmitting Beam Power Amplifier

Illustrated on page 84

RCA-814 is a filament type of transmitting tube incorporating new design principles involving the use of directed electron beams. Features resulting from the use of these principles in the 814 are that the screen absorbs little power and that efficient suppressor action is supplied by space-charge effects produced between the screen and the plate. The resultant high power sensitivity makes this tube especially suited for use as an r-f amplifier, frequency multiplier, oscillator, and plate-modulated amplifier. The plate connection is brought out through a separate seal at the top of the bulb to maintain low grid-plate capacitance. The 814 may be operated at maximum ratings in all classes of service at frequencies as high as 30 megacycles. RCA-814 has a ceramic base.

### TENTATIVE CHARACTERISTICS AND RATINGS

Filament Volts (a-c or d-c) .....	10.0	Grid-Plate Capacitance (With	
Filament Amperes .....	3.25	external shielding) .....	0.1 max. $\mu\text{f}$
Transconductance (For plate current		Input Capacitance .....	13.5 $\mu\text{f}$
of 39 ma.) Micromhos, approx.....	3300	Output Capacitance .....	13.5 $\mu\text{f}$

### MAXIMUM RATINGS AND TYPICAL OPERATING CONDITIONS

#### As R-F Power Amplifier—Class B Telephony

*Carrier conditions per tube for use with a max. modulation factor of 1.0*

D-C PLATE VOLTAGE .....	1250	max. Volts
D-C SCREEN VOLTAGE (Grid No. 2) .....	300	max. Volts
D-C PLATE CURRENT .....	60	max. Milliamperes
PLATE INPUT .....	75	max. Watts
SCREEN INPUT .....	6.7	max. Watts
PLATE DISSIPATION .....	50	max. Watts

#### TYPICAL OPERATION:

D-C Plate Voltage .....	1000	1250	Volts
D-C Screen Voltage .....	200	200	Volts
D-C Grid Voltage (Grid No. 1)* .....	-28	-28	Volts
Peak R-F Grid Voltage .....	50	50	Volts
Beam-Forming-Plate Voltage <sup>§</sup> .....	0	0	Volts
D-C Plate Current .....	60	60	Milliamperes
D-C Screen Current .....	1.3	1	Milliamperes
D-C Grid Current (Approx.) .....	1.8	1.8	Milliamperes
Driving Power (Approx.) <sup>†</sup> .....	0.65	0.65	Watt
Power Output (Approx.) .....	20	25	Watts

#### As Grid-Modulated R-F Power Amplifier—Class C Telephony

*Carrier conditions per tube for use with a max. modulation factor of 1.0*

D-C PLATE VOLTAGE .....	1250	max. Volts
D-C SCREEN VOLTAGE (Grid No. 2) .....	300	max. Volts
D-C GRID VOLTAGE (Grid No. 1) .....	-250	max. Volts
D-C PLATE CURRENT .....	60	max. Milliamperes
PLATE INPUT .....	75	max. Watts
SCREEN INPUT .....	6.7	max. Watts
PLATE DISSIPATION .....	50	max. Watts

#### TYPICAL OPERATION:

D-C Plate Voltage .....	1000	1250	Volts
D-C Screen Voltage .....	200	200	Volts
D-C Grid Voltage* .....	-100	-100	Volts
Peak R-F Grid Voltage .....	129	129	Volts
Peak A-F Grid Voltage .....	64	64	Volts
Beam-Forming-Plate Voltage <sup>§</sup> .....	0	0	Volts

\* , §, †: see next page.

D-C Plate Current .....	60	60	Milliamperes
D-C Screen Current .....	2	1.4	Milliamperes
D-C Grid Current (Approx.) .....	3	2.8	Milliamperes
Driving Power (Approx.)† .....	2.5	2.3	Watts
Power Output (Approx.) .....	25	29	Watts

### As Plate-Modulated R-F Power Amplifier—Class C Telephony

Carrier conditions per tube for use with a max. modulation factor of 1.0

D-C PLATE VOLTAGE .....	1000	max.	Volts
D-C SCREEN VOLTAGE (Grid No. 2) .....	300	max.	Volts
D-C GRID VOLTAGE (Grid No. 1) .....	-300	max.	Volts
D-C PLATE CURRENT .....	120	max.	Milliamperes
D-C GRID CURRENT .....	10	max.	Milliamperes
PLATE INPUT .....	120	max.	Watts
SCREEN INPUT .....	6.7	max.	Watts
PLATE DISSIPATION .....	34	max.	Watts

#### TYPICAL OPERATION:

D-C Plate Voltage .....	900	1000	Volts
D-C Screen Voltage .....	300	300	Volts
D-C Grid Voltage* .....	-150	-150	Volts
Peak R-F Grid Voltage.....	215	222	Volts
Beam-Forming-Plate Voltage‡ .....	0	0	Volts
D-C Plate Current .....	120	120	Milliamperes
D-C Screen Current .....	15	17.5	Milliamperes
D-C Grid Current (Approx.) .....	10	10	Milliamperes
Screen Resistor† .....	40000	40000	Ohms
Grid Resistor .....	15000	15000	Ohms
Driving Power (Approx.) .....	2	2	Watts
Power Output (Approx.) .....	76	87	Watts

### As R-F Power Amplifier and Oscillator—Class C Telegraphy

Key-down conditions per tube without modulation††

D-C PLATE VOLTAGE .....	1250	max.	Volts
D-C SCREEN VOLTAGE (Grid No. 2) .....	300	max.	Volts
D-C GRID VOLTAGE (Grid No. 1) .....	-300	max.	Volts
D-C PLATE CURRENT .....	150	max.	Milliamperes
D-C GRID CURRENT .....	10	max.	Milliamperes
PLATE INPUT .....	180	max.	Watts
SCREEN INPUT .....	10	max.	Watts
PLATE DISSIPATION .....	50	max.	Watts

#### TYPICAL OPERATION:

D-C Plate Voltage .....	1000	1250	Volts
D-C Screen Voltage .....	300	300	Volts
D-C Grid Voltage* .....	-70	-80	Volts
Peak R-F Grid Voltage .....	150	165	Volts
Beam-Forming-Plate Voltage‡ .....	0	0	Volts
D-C Plate Current .....	150	144	Milliamperes
D-C Screen Current .....	17.5	22.5	Milliamperes
D-C Grid Current (Approx.).....	10	10	Milliamperes
Screen Resistor .....	Not recommended		
Grid Resistor .....	7000	8000	Ohms
Driving Power (Approx.) .....	1.35	1.5	Watts
Power Output (Approx.).....	100	130	Watts

\* Grid voltages are given with respect to the mid-point of filament circuit operated on a.c. If d.c. is used, each stated value of grid voltage should be decreased by 7 volts and the circuit returns made to the negative end of the filament.

‡ Beam-forming plates should be connected to the mid-point of filament circuit operated on a.c. or to the negative end of the filament, when a d-c filament supply is used.

† At crest of audio-frequency cycle with modulation factor of 1.0.

‡ Connected to modulated plate-voltage supply.

†† Modulation essentially negative may be used if the positive peak of the audio-frequency envelope does not exceed 115% of the carrier conditions.

## INSTALLATION AND APPLICATION

The base pins of the RCA-814 fit the standard 5-contact socket which should be installed to hold the tube in a vertical position with the base down. If it is necessary to place the tube in a horizontal position, the socket should be mounted with the filament-pin openings one vertically above the other so that the filament will be in a vertical plane (on edge).

The beam-forming plates of the 814 are connected to a separate base pin. They should always be operated at zero potential with respect to the filament; never positive. When the filament is operated from an a-c supply, the beam-forming plates should be connected to the mid-point of the filament circuit. When the filament is operated from a d-c supply, they should be connected to the negative end of the filament.

The plate of the 814 shows no color at the maximum plate-dissipation rating for each class of service. The screen should never be allowed to show color.

For high-frequency operation above 30 megacycles, see page 144.

For additional information, see chapters on INSTALLATION and APPLICATION.

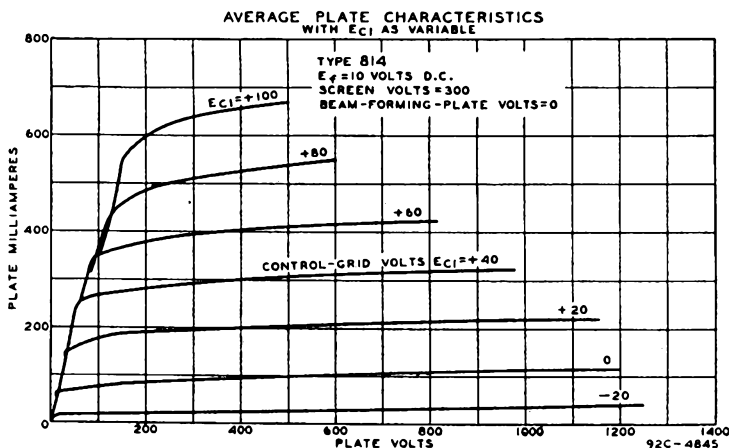

Top View of Socket Connections

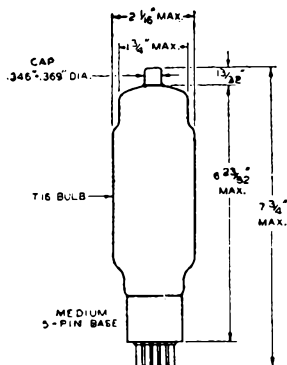
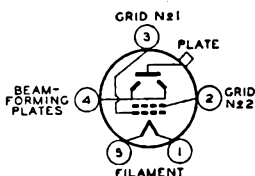

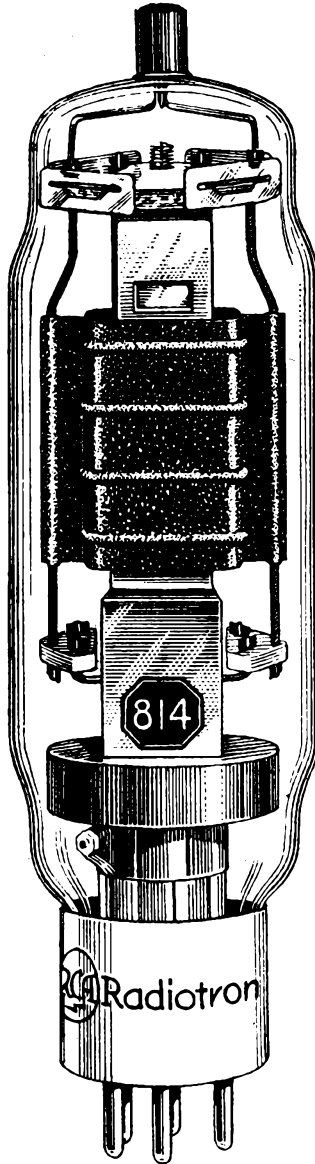

### RCA-814

Beam power amplifier—large power gain—high efficiency—easily driven—no neutralization—features combine to make this type ideal for many commercial and amateur applications.

# RCA-830-B

## R-F Power Amplifier, Oscillator, Class B Modulator

RCA-830-B is a three-electrode transmitting tube of the thoriated-tungsten filament type for use as a radio-frequency amplifier, oscillator and class B audio-frequency amplifier. The plate connection is brought out through a separate seal at the top of the bulb. As an r-f amplifier or oscillator, the 830-B can be operated at maximum rated conditions at frequencies as high as 15 megacycles. The plate dissipation for class C telegraph and class B services is 60 watts. In class B audio service two tubes of this type are capable of delivering an output of 175 watts.

### CHARACTERISTICS

Filament Volts (a-c or d-c).....	10.0	Grid-Plate Capacitance .....	11 $\mu\text{f}$
Filament Amperes .....	2	Grid-Filament Capacitance .....	5 $\mu\text{f}$
Amplification Factor .....	25	Plate-Filament Capacitance .....	1.8 $\mu\text{f}$

### MAXIMUM RATINGS AND TYPICAL OPERATING CONDITIONS

#### As A-F Power Amplifier and Modulator—Class B

D-C PLATE VOLTAGE .....	1000	max.	Volts
MAX. SIGNAL D-C PLATE CURRENT* .....	150	max.	Milliamperes
MAX. SIGNAL PLATE INPUT* .....	150	max.	Watts
PLATE DISSIPATION* .....	60	max.	Watts

#### TYPICAL OPERATION:

*Unless otherwise specified, values are for 2 tubes*

D-C Plate Voltage .....	800	1000	Volts
D-C Grid Voltage <sup>§</sup> .....	-27	-35	Volts
Peak A-F Grid-to-Grid Voltage .....	250	270	Volts
Zero-Sig. D-C Plate Current .....	20	20	Milliamperes
Max.-Sig. D-C Plate Current .....	280	280	Milliamperes
Load Resistance (Per tube) .....	1500	1900	Ohms
Effective Load Res. (Plate-to-plate) .....	6000	7600	Ohms
Max.-Sig. Driving Power (Approx.) .....	5	6	Watts
Max.-Sig. Power Output (Approx.) .....	135	175	Watts

#### As R-F Power Amplifier—Class B Telephony

*Carrier conditions per tube for use with a max. modulation factor of 1.0*

D-C PLATE VOLTAGE .....	1000	max.	Volts
D-C PLATE CURRENT .....	100	max.	Milliamperes
PLATE INPUT .....	90	max.	Watts
PLATE DISSIPATION .....	60	max.	Watts

#### TYPICAL OPERATION:

D-C Plate Voltage .....	800	1000	Volts
D-C Grid Voltage <sup>§</sup> .....	-27	-35	Volts
Peak R-F Grid Voltage .....	85	85	Volts
D-C Plate Current .....	95	85	Milliamperes
D-C Grid Current (Approx.) .....	7	6	Milliamperes
Driving Power (Approx.) <sup>†</sup> .....	9	6	Watts
Power Output (Approx.) .....	23	26	Watts

\*. §. †: see next page.

**As Plate-Modulated R-F Power Amplifier—Class C Telephony***Carrier conditions per tube for use with a max. modulation factor of 1.0*

D-C PLATE VOLTAGE .....	800	max.	Volts
D-C GRID VOLTAGE .....	-300	max.	Volts
D-C PLATE CURRENT .....	100	max.	Milliamperes
D-C GRID CURRENT .....	30	max.	Milliamperes
PLATE INPUT .....	80	max.	Watts
PLATE DISSIPATION .....	40	max.	Watts

**TYPICAL OPERATION:**

D-C Plate Voltage .....	600	800	Volts
D-C Grid Voltage§ .....	-140	-150	Volts
Peak R-F Grid Voltage .....	255	265	Volts
D-C Plate Current .....	95	95	Milliamperes
D-C Grid Current (Approx.) .....	30	20	Milliamperes
Grid Resistor .....	4700	7500	Ohms
Driving Power (Approx.) .....	7	5	Watts
Power Output (Approx.) .....	38	50	Watts

**As R-F Power Amplifier and Oscillator—Class C Telegraphy***Key-down conditions per tube without modulation††*

D-C PLATE VOLTAGE .....	1000	max.	Volts
D-C GRID VOLTAGE .....	-300	max.	Volts
D-C PLATE CURRENT .....	150	max.	Milliamperes
D-C GRID CURRENT .....	30	max.	Milliamperes
PLATE INPUT .....	150	max.	Watts
PLATE DISSIPATION .....	60	max.	Watts

**TYPICAL OPERATION:**

D-C Plate Voltage .....	600	800	1000	Volts
D-C Grid Voltage§ .....	-95	-105	-110	Volts
Peak R-F Grid Voltage .....	235	245	250	Volts
D-C Plate Current .....	140	140	140	Milliamperes
D-C Grid Current (Approx.) .....	30	30	30	Milliamperes
Grid Resistor .....	3160	3500	3670	Ohms
Driving Power (Approx.) .....	7	7	7	Watts
Power Output (Approx.) .....	45	70	90	Watts

\* Averaged over any audio-frequency cycle of sine-wave form.

§ Grid voltages are given with respect to the mid-point of filament operated on a.c. If d.c. is used, each stated value of grid voltage should be decreased by 7 volts and the circuit returns made to the negative end of the filament.

† At crest of audio-frequency cycle with modulation factor of 1.0.

†† Modulation essentially negative may be used if the positive peak of the audio-frequency envelope does not exceed 115% of the carrier conditions.

**INSTALLATION AND APPLICATION**

The base pins of the 830-B fit the standard 4-contact socket, such as the RCA type UR-542A. The socket should be mounted to hold the tube in a vertical position with base down. The plate lead is brought out to the cap at the top of the bulb.

The plate of the 830-B shows only a barely perceptible red color at the maximum plate-dissipation rating for each class of service.

For high-frequency operation above 15 megacycles, see page 144.

For additional information, see chapters on INSTALLATION and APPLICATION.

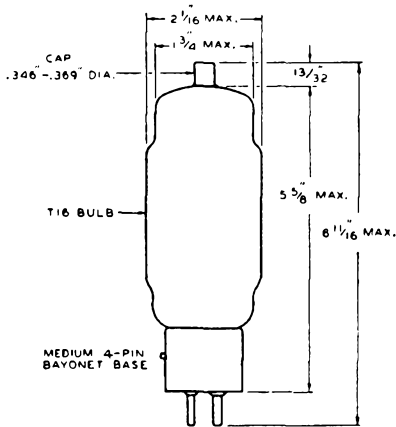
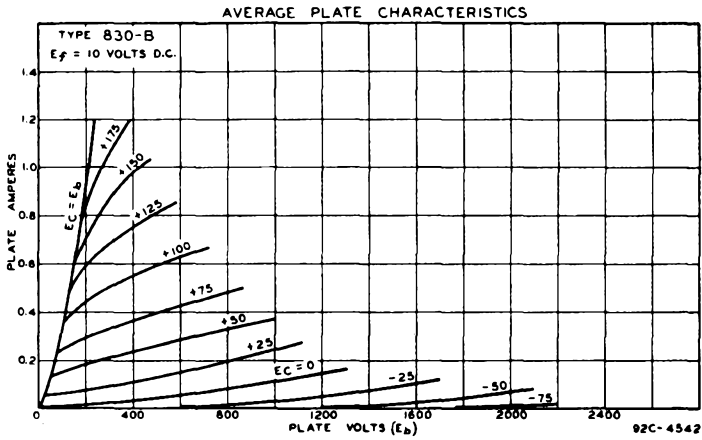

**Top View of Socket Connections**

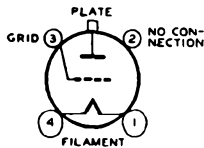



# RCA-831

## R-F Power Amplifier, Oscillator

RCA-831 is a high-power, air-cooled transmitting tube of the three-electrode type containing a thoriated-tungsten filament. Each electrode is supported on a separate stem and each electrode lead is brought out of the bulb through a separate seal. The 831 can be operated at maximum ratings at frequencies as high as 20 megacycles. The plate dissipation for class C telegraph and class B services is 400 watts.

### CHARACTERISTICS

Filament Volts (a-c or d-c) .....	11.0	Grid-Plate Capacitance .....	4 $\mu\text{f}$
Filament Amperes .....	10	Grid-Filament Capacitance .....	3.8 $\mu\text{f}$
Amplification Factor .....	14.5	Plate-Filament Capacitance .....	1.4 $\mu\text{f}$

### MAXIMUM RATINGS

	Class B Tele- phony*	Class C Tele- phony*	Class C Tele- graphy**	
D-C PLATE VOLTAGE .....	3500	3000	3500	Volts
D-C GRID VOLTAGE .....	—	-1000	-1000	Volts
D-C PLATE CURRENT .....	250	300	350	Milliamperes
D-C GRID CURRENT .....	—	75	75	Milliamperes
PLATE INPUT .....	600	650	1200	Watts
PLATE DISSIPATION .....	400	270	400	Watts

\* Carrier conditions per tube with a max. modulation factor of 1.0.

\*\* Key-down conditions per tube without modulation. Modulation essentially negative may be used if the positive peak of the audio-frequency envelope does not exceed 115% of the carrier conditions.

### INSTALLATION AND APPLICATION

The filament base and grid cap of the 831 fit the standard RCA end mountings UT-1085 and UT-1086, respectively. The tube must be mounted in a vertical position with the grid cap down.

The plate of the 831 shows an orange-red color at the maximum plate-dissipation rating for each class of service.

For high-frequency operation above 20 megacycles, see page 144.

For additional information, see chapters on INSTALLATION and APPLICATION.

#### Connections to End-Mountings

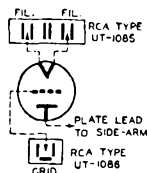
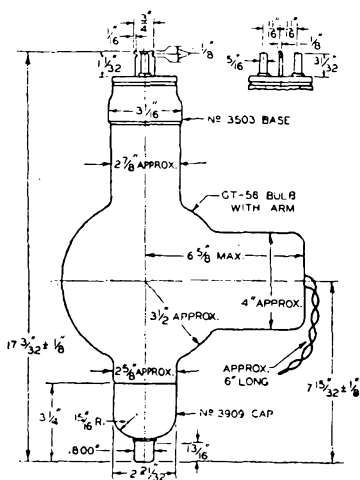

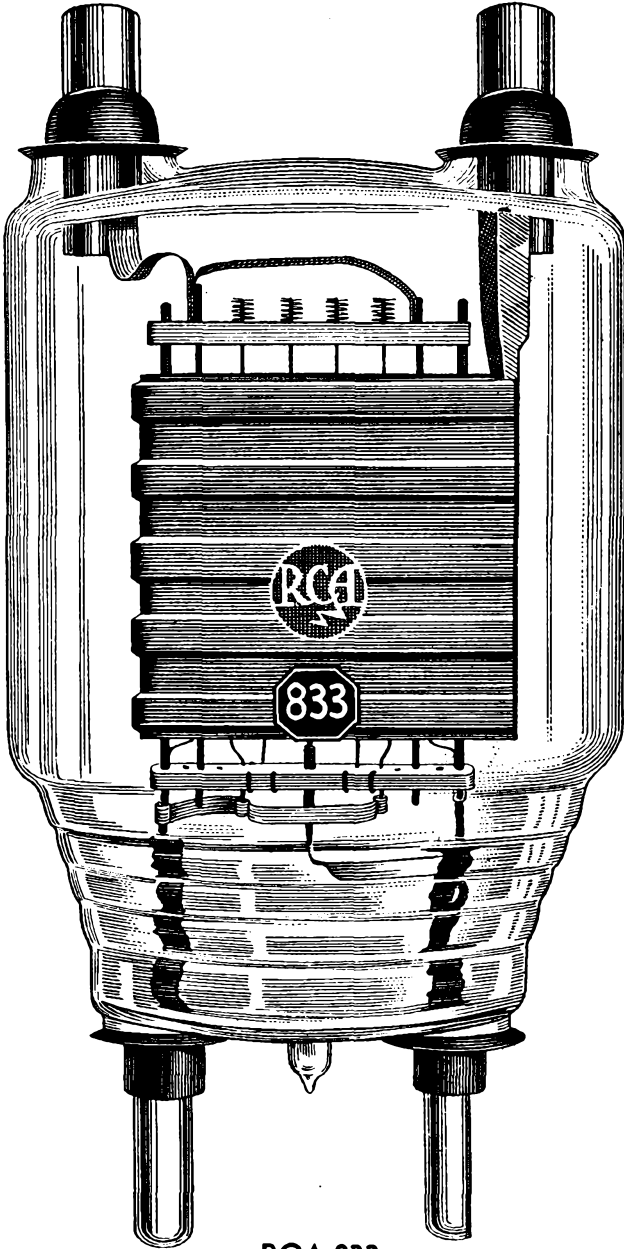

**RCA-833**

A new heavy-duty, tantalum-plate triode for high-power, high-frequency applications—its reliability and efficiency make it ideal for commercial applications.

## R-F Power Amplifier, Oscillator

*Illustrated on page 89*

RCA-833 is a three-electrode, high- $\mu$  transmitting tube of the thoriated-tungsten filament type for use as a radio-frequency amplifier, oscillator, and class B modulator. Because of its high perveance, the 833 can be operated at high plate efficiency with low driving power. Designed in a new way with post terminals which provide a rugged structure and make bases unnecessary, RCA-833 has a minimum amount of insulation within the tube. The plate is supported directly from its post terminal at the top of the tube. As a result of its construction, the 833 can be operated in class C telegraph service with maximum input of 1250 watts at frequencies as high as 30 megacycles, and with reduced input at frequencies as high as 100 megacycles.

### TENTATIVE CHARACTERISTICS AND RATINGS

Filament Volts (a-c or d-c) .....	10.0	Grid-Plate Capacitance .....	6.3 $\mu\text{f}$
Filament Amperes .....	10	Grid-Filament Capacitance .....	12.3 $\mu\text{f}$
Amplification Factor .....	35	Plate-Filament Capacitance .....	8.5 $\mu\text{f}$

### MAXIMUM RATINGS AND TYPICAL OPERATING CONDITIONS

#### As A-F Power Amplifier and Modulator—Class B

D-C PLATE VOLTAGE .....	3000	max.	Volts
MAX.-SIGNAL D-C PLATE CURRENT* .....	500	max.	Milliamperes
MAX.-SIGNAL PLATE INPUT* .....	1125	max.	Watts
PLATE DISSIPATION* .....	300	max.	Watts

#### TYPICAL OPERATION:

*Unless otherwise specified, values are for 2 tubes*

D-C Plate Voltage .....	2500	2650	3000	Volts
D-C Grid Voltage <sup>§</sup> .....	-57	-62	-70	Volts
Peak A-F Grid-to-Grid Voltage .....	380	300	400	Volts
Zero-Sig. D-C Plate Current .....	100	100	100	Milliamperes
Max.-Sig. D-C Plate Current .....	800	520	750	Milliamperes
Load Resistance (Per tube) .....	1825	2600	2375	Ohms
Effective Load Res. (Plate-to-plate) .....	7300	10400	9500	Ohms
Max.-Sig. Driving Power (Approx.) .....	15	5	20	Watts
Max.-Sig. Power Output (Approx.) .....	1425	840	1650	Watts

#### As R-F Power Amplifier—Class B Telephony

*Carrier conditions per tube for use with a max. modulation factor of 1.0*

D-C PLATE VOLTAGE .....	3000	max.	Volts
D-C PLATE CURRENT .....	400	max.	Milliamperes
PLATE INPUT .....	450	max.	Watts
PLATE DISSIPATION .....	300	max.	Watts

#### TYPICAL OPERATION:

D-C Plate Voltage .....	2500	3000	Volts
D-C Grid Voltage <sup>§</sup> .....	-60	-70	Volts
Peak R-F Grid Voltage .....	80	90	Volts
D-C Plate Current .....	150	150	Milliamperes
D-C Grid Current (Approx.) .....	2	2	Milliamperes
Driving Power (Approx.) <sup>†</sup> .....	10	10	Watts
Power Output (Approx.) .....	125	150	Watts

#### As Plate-Modulated R-F Power Amplifier—Class C Telephony

*Carrier conditions per tube for use with a max. modulation factor of 1.0*

D-C PLATE VOLTAGE .....	2500	max.	Volts
D-C GRID VOLTAGE .....	-500	max.	Volts
D-C PLATE CURRENT .....	400	max.	Milliamperes
D-C GRID CURRENT .....	75	max.	Milliamperes
PLATE INPUT .....	835	max.	Watts
PLATE DISSIPATION .....	200	max.	Watts

\* , § , † : see next page.

TYPICAL OPERATION:

D-C Plate Voltage .....	2000	2500	Volts
D-C Grid Voltage .....	-300	-300	Volts
Peak R-F Grid Voltage .....	460	460	Volts
D-C Plate Current .....	375	335	Milliamperes
D-C Grid Current (Approx.) .....	75	75	Milliamperes
Driving Power (Approx.) .....	30	30	Watts
Power Output (Approx.) .....	550	635	Watts

As R-F Power Amplifier and Oscillator—Class C Telegraphy

Key-down conditions per tube without modulation††

D-C PLATE VOLTAGE .....	3000 max.	Volts
D-C GRID VOLTAGE .....	-500 max.	Volts
D-C PLATE CURRENT .....	500 max.	Milliamperes
D-C GRID CURRENT .....	75 max.	Milliamperes
PLATE INPUT .....	1250 max.	Watts
PLATE DISSIPATION .....	300 max.	Watts

TYPICAL OPERATION:

D-C Plate Voltage .....	2500	3000	Volts
D-C Grid Voltage .....	-200	-200	Volts
Peak R-F Grid Voltage .....	390	360	Volts
D-C Plate Current .....	475	415	Milliamperes
D-C Grid Current (Approx.) .....	65	55	Milliamperes
Driving Power (Approx.) .....	25	20	Watts
Power Output (Approx.) .....	925	1000	Watts

\* Averaged over any audio-frequency cycle of sine-wave form.

† At crest of audio-frequency cycle with modulation factor of 1.0.

†† Modulation essentially negative may be used if the positive peak of the audio-frequency envelope does not exceed 115% of the carrier conditions.

‡ Grid voltages are given with respect to the mid-point of filament operated on a.c. If d.c. is used, each stated value of grid voltage should be decreased by 7 volts and the circuit returns made to the negative end of the filament.

INSTALLATION AND APPLICATION

FREQUENCY PERFORMANCE CHARACTERISTICS UNMODULATED CLASS C AMPLIFIER & OSCILLATOR

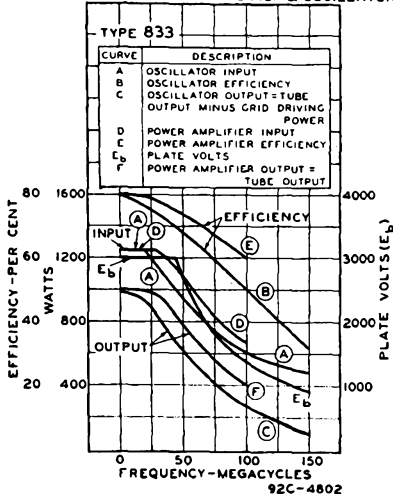

Terminal connections for the 833 can be conveniently made with the special connectors, collectively identified as RCA type UT-103. The UT-103 consists of one polarized mounting, type MI-7477, for the filament, and two connectors, MI-7478, for the grid and plate. RCA-833 may be operated in either a vertical or a horizontal position. When the tube is operated in a horizontal position, it should be mounted with the plate in a vertical plane (on edge). Special grid- and plate-post connectors, such as the RCA type MI-7478, should be used when the tube is operated at frequencies above 15 Mc. The connectors aid in cooling the terminal posts and their seals.

The plate of the 833 shows an orange-red color at the maximum plate-dissipation rating for each class of service.

The maximum ratings of the RCA-833 at high frequencies are shown on the curve on page 91. The improved efficiency for amplifier service is made possible by the fact that the input and output circuits of an amplifier are isolated, so that the plate-voltage phase may be adjusted independently of the applied grid voltage.

For additional information, see chapters on INSTALLATION and APPLICATION.

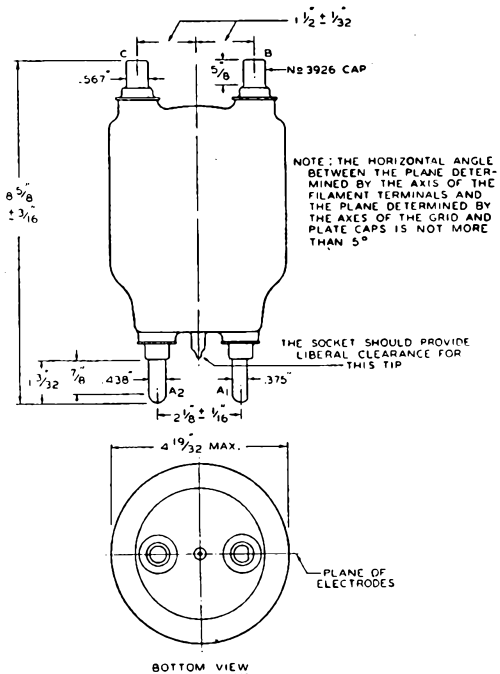

Connections to End-Mountings

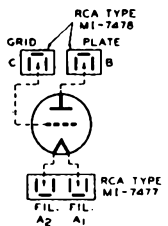

TWO MI-7478 } ARE DESIGNATED AS  
ONE MI-7477 }

RCA SOCKET ASSEMBLY UT-103

AVERAGE PLATE CHARACTERISTICS

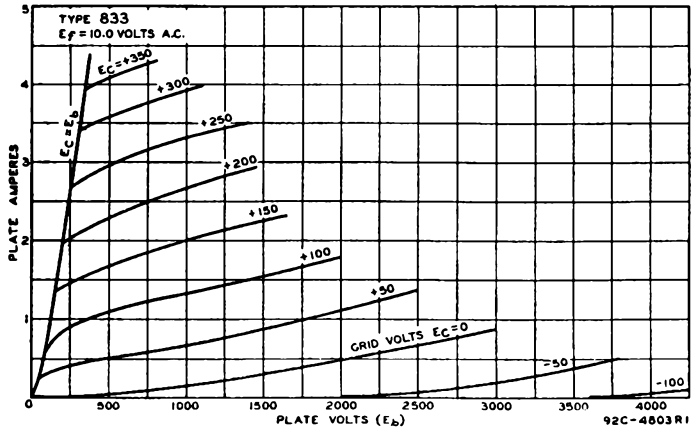

# RCA-834

## R-F Power Amplifier, Oscillator

Illustrated on page 42

RCA-834 is a three-electrode transmitting tube of the thoriated-tungsten filament type for use as a radio-frequency amplifier and oscillator, particularly at the higher radio frequencies. The grid and plate are supported from the top of the glass bulb by individual leads which are brought out of the tube through separate seals. This construction insures low interelectrode capacitances and minimum lead inductance. RCA-834 may be operated at maximum ratings at frequencies as high as 100 megacycles; it may be operated at reduced plate voltage and input up to 350 megacycles. The maximum plate dissipation for class C telegraph and class B services is 50 watts.

### CHARACTERISTICS

Filament Volts (a-c or d-c) .....	7.5	Grid-Plate Capacitance .....	2.6 $\mu\text{f}$
Filament Amperes .....	3.25	Grid-Filament Capacitance .....	2.2 $\mu\text{f}$
Amplification Factor .....	10.5	Plate-Filament Capacitance .....	0.6 $\mu\text{f}$

### MAXIMUM RATINGS AND TYPICAL OPERATING CONDITIONS

#### As R-F Power Amplifier—Class B Telephony

Carrier conditions per tube for use with a max. modulation factor of 1.0

D-C PLATE VOLTAGE .....	1250 max.	Volts
D-C PLATE CURRENT .....	100 max.	Milliamperes
PLATE INPUT .....	75 max.	Watts
PLATE DISSIPATION .....	50 max.	Watts

#### TYPICAL OPERATION:

D-C Plate Voltage .....	750	1000	1250	Volts
D-C Grid Voltage <sup>§</sup> .....	-70	-90	-115	Volts
Peak R-F Grid Voltage .....	90	100	115	Volts
D-C Plate Current .....	50	50	50	Milliamperes
D-C Grid Current (Approx.) .....	1	0.5	0	Milliampere
Driving Power (Approx.) <sup>†</sup> .....	3.3	3.1	3	Watts
Power Output (Approx.) .....	11	16	20	Watts

#### As Plate-Modulated R-F Power Amplifier—Class C Telephony

Carrier conditions per tube for use with a max. modulation factor of 1.0

D-C PLATE VOLTAGE .....	1000 max.	Volts
D-C GRID VOLTAGE .....	-400 max.	Volts
D-C PLATE CURRENT .....	100 max.	Milliamperes
D-C GRID CURRENT .....	20 max.	Milliamperes
PLATE INPUT .....	100 max.	Watts
PLATE DISSIPATION .....	35 max.	Watts

#### TYPICAL OPERATION:

D-C Plate Voltage .....	750	1000	Volts
D-C Grid Voltage <sup>§</sup> .....	-290	-310	Volts
Peak R-F Grid Voltage .....	415	435	Volts
D-C Plate Current .....	90	90	Milliamperes
D-C Grid Current (Approx.) .....	20	17.5	Milliamperes
Grid Resistor .....	14500	17710	Ohms
Driving Power (Approx.) .....	7.5	6.5	Watts
Power Output (Approx.) .....	42	58	Watts

§, †: see next page.

## As R-F Power Amplifier and Oscillator—Class C Telegraphy

Key-down conditions per tube without modulation††

D-C PLATE VOLTAGE .....	1250 max.	Volts
D-C GRID VOLTAGE .....	-400 max.	Volts
D-C PLATE CURRENT .....	100 max.	Milliamperes
D-C GRID CURRENT .....	20 max.	Milliamperes
PLATE INPUT .....	125 max.	Watts
PLATE DISSIPATION .....	50 max.	Watts

## TYPICAL OPERATION:

D-C Plate Voltage .....	750	1000	1250	Volts
D-C Grid Voltage <sup>§</sup> .....	-175	-200	-225	Volts
Peak R-F Grid Voltage .....	300	325	350	Volts
D-C Plate Current .....	90	90	90	Milliamperes
D-C Grid Current (Approx.) .....	20	17.5	15	Milliamperes
Grid Resistor .....	8750	11400	15000	Ohms
Driving Power (Approx.) .....	5.5	5	4.5	Watts
Power Output (Approx.) .....	42	58	75	Watts

§ Grid voltages are given with respect to the mid-point of filament operated on a-c. If d-c is used, each stated value of grid voltage should be decreased by 5 volts and the circuit returns made to the negative end of the filament.

† At crest of audio-frequency cycle with modulation factor of 1.0.

†† Modulation essentially negative may be used if the positive peak of the audio-frequency envelope does not exceed 115% of the carrier conditions.

## INSTALLATION AND APPLICATION

The base pins of the 834 fit the standard four-contact socket, such as the RCA type UR-542A. The socket should be installed to hold the tube in a vertical position. The filament terminals are connected to the two large base pins; the grid and plate leads are brought out through separate seals at the top of the bulb. See outline drawing.

Connections to the grid and plate leads must be flexible enough so that normal expansion will not place a strain on the glass at the seals, yet heavy enough to carry the high circulating r-f current. It is also necessary to provide a means for cooling the lead tips and their seals. A recommended method of doing this is to increase the radiating surface of each lead by means of a copper clamp connector having a cross-sectional area of at least  $\frac{3}{4}$  inch square. (See next page for constructional details.) Each lead wire should be connected to its copper clamp before the clamp is placed on the terminal tip. The clamp should be slightly sprung so that it can easily be slipped over its terminal. When the clamp is in place, carefully tighten the smaller bolt to insure good electrical contact. Connections should never be soldered directly to the tube terminal tips as the heat of the soldering operation may result in the cracking of the lead seals. The tube terminal tips should not be used to support coils, condensers, chokes, or other circuit parts.

The bulb becomes very hot during continuous operation. Therefore free circulation of air about the bulb should be provided. When the 834 is operated at frequencies higher than 60 megacycles, forced cooling of the tube is recommended. This may be done by means of a small electric fan. Under any condition of operation the maximum bulb temperature should not exceed 175°C (347°F) as measured by a thermometer placed against the glass at the top of the tube, midway between the grid and plate leads.

The plate of the 834 shows only a barely perceptible red color at the maximum plate-dissipation rating for each class of service.

For high-frequency operation above 100 megacycles, see page 144.

For additional information, see chapters on INSTALLATION and APPLICATION.

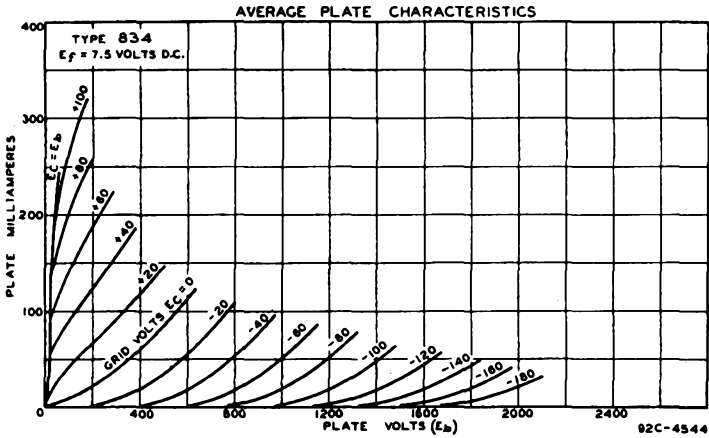

**RADIATING CONNECTOR**

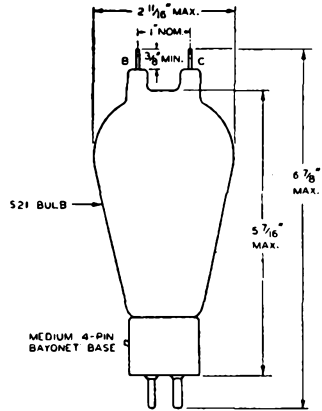
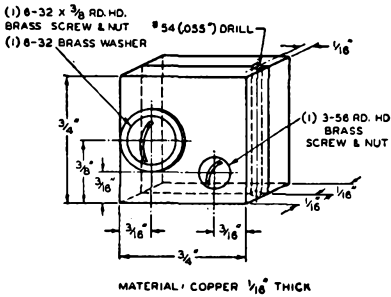

**Top View of Socket Connections**

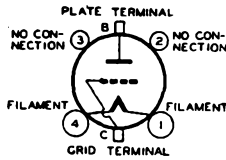



# RCA-836

## Half-Wave High-Vacuum Rectifier

RCA-836 is a high-vacuum, half-wave rectifier tube of the heater-cathode type for use in high-voltage rectifying devices to supply d-c power. The excellent voltage regulation characteristic of this tube is due to the close spacing of the cathode and plate, and to the use of double cathode construction. In single-phase circuits, full-wave rectification is accomplished by using two 836's.

### CHARACTERISTICS

HEATER VOLTAGE (a-c) .....	2.5	Volts
HEATER CURRENT .....	5	Amperes
PEAK INVERSE VOLTAGE .....	5000 max.	Volts
PEAK PLATE CURRENT .....	1.0 max.	Ampere
AVERAGE PLATE CURRENT .....	0.25 max.	Ampere

### INSTALLATION AND APPLICATION

The base pins of the 836 fit the standard 4-contact socket, such as the RCA type UR-542A. The socket may be mounted to hold the tube in any position. The plate lead is brought out to the cap at the top of the bulb.

Heater voltage should be applied for a length of time sufficient to permit the cathode to come up to operating temperature before plate current is drawn from the tube. For average conditions, the delay should be approximately 40 seconds.

The cathode of the RCA-836 is connected to one side of the heater circuit within the tube. When the positive return lead to the filter and load circuit is not connected to the electrical mid-point of the heater circuit, it should be connected to the heater lead to which the cathode is tied. When the heaters of two or more 836's are operated in parallel, the corresponding cathode leads must be connected together: likewise, the corresponding heater leads.

For outline drawing, refer to type 809.

For additional information, see chapter on RECTIFIERS and FILTERS.

Top View of Socket Connections

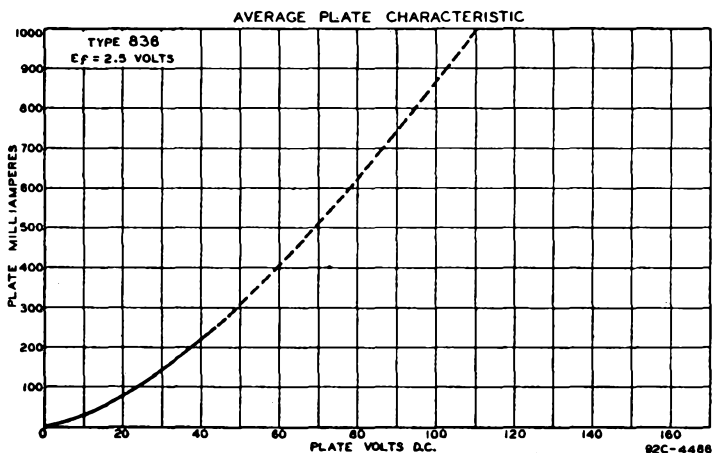
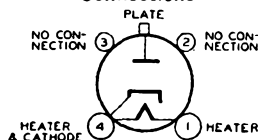

# RCA-837

## R-F Power Amplifier Pentode

RCA-837 is a pentode transmitting tube of the heater-cathode type for use as an r-f amplifier, frequency-multiplier, oscillator, and suppressor-, grid- or plate-modulated amplifier. The plate connection is brought out through a separate seal at the top of the bulb to maintain low grid-plate capacitance. Neutralization to prevent feedback and self-oscillation is generally unnecessary in adequately shielded circuits. The suppressor and the special internal shield are connected to individual base pins. RCA-837 has a ceramic base.

### CHARACTERISTICS

Heater Volts (a-c or d-c) .....	12.6	Grid-Plate Capacitance (With	
Heater Amperes .....	0.7	external shielding) .....	0.20 max. $\mu\mu\text{f}$
Transconductance (For plate current		Input Capacitance .....	16 $\mu\mu\text{f}$
of 24 ma.) Micromhos .....	3400	Output Capacitance .....	10 $\mu\mu\text{f}$

### MAXIMUM RATINGS AND TYPICAL OPERATING CONDITIONS

#### As R-F Power Amplifier Pentode—Class B Telephony

*Carrier conditions per tube for use with a max. modulation factor of 1.0*

D-C PLATE VOLTAGE .....	500	max. Volts
D-C SUPPRESSOR VOLTAGE (Grid No. 3) .....	200	max. Volts
D-C SCREEN VOLTAGE (Grid No. 2) .....	200	max. Volts
D-C PLATE CURRENT .....	40	max. Milliamperes
PLATE INPUT .....	16	max. Watts
SUPPRESSOR INPUT .....	5	max. Watts
SCREEN INPUT .....	5	max. Watts
PLATE DISSIPATION .....	12	max. Watts

#### TYPICAL OPERATION:

D-C Plate Voltage .....	400	500	500	Volts
D-C Suppressor Voltage .....	0	0	40	Volts
D-C Screen Voltage .....	200	200	200	Volts
D-C Grid Voltage (Grid No. 1) .....	-25	-25	-25	Volts
Peak R-F Grid Voltage .....	28	25	24	Volts
Internal Shield .....	Connected to cathode at socket			
D-C Plate Current .....	35	30	30	Milliamperes
D-C Screen Current .....	10	15	12	Milliamperes
D-C Grid Current (Approx.) .....	1	0	0	Milliampere
Driving Power (Approx.) <sup>†</sup> .....	0.4	0.2	0.1	Watt
Power Output (Approx.) .....	4	5	5.5	Watts

#### As Suppressor-Modulated R-F Power Amplifier—Class C Telephony

*Carrier conditions per tube for use with a max. modulation factor of 1.0*

D-C PLATE VOLTAGE .....	500	max. Volts
D-C SCREEN VOLTAGE (Grid No. 2) .....	200	max. Volts
D-C GRID VOLTAGE (Grid No. 1) .....	-200	max. Volts
D-C PLATE CURRENT .....	40	max. Milliamperes
D-C GRID CURRENT .....	8	max. Milliamperes
PLATE INPUT .....	16	max. Watts
SCREEN INPUT .....	8	max. Watts
PLATE DISSIPATION .....	12	max. Watts

#### TYPICAL OPERATION:

D-C Plate Voltage .....	400	500	Volts
D-C Suppressor Voltage (Grid No. 3) .....	-55	-65	Volts

<sup>†</sup>: see end of tabulation.

D-C Grid Voltage .....	-20	-20	Volts
Peak R-F Grid Voltage .....	45	32	Volts
Peak A-F Suppressor Voltage .....	55	65	Volts
Internal Shield .....	Connected to cathode at socket		
D-C Plate Current .....	35	30	Milliamperes
D-C Screen Current .....	37	23	Milliamperes
D-C Grid Current (Approx.) .....	8	3.5	Milliamperes
Screen Resistor .....	6500	14000	Ohms
Grid Resistor .....	2500	5700	Ohms
Driving Power (Approx.) .....	0.4	0.1	Watt
Power Output (Approx.) .....	4	5	Watts

### As Grid-Modulated R-F Power Amplifier Pentode—Class C Telephony

Carrier conditions per tube for use with a max. modulation factor of 1.0

D-C PLATE VOLTAGE .....	500	max.	Volts
D-C SUPPRESSOR VOLTAGE (Grid No. 3) .....	200	max.	Volts
D-C SCREEN VOLTAGE (Grid No. 2) .....	200	max.	Volts
D-C GRID VOLTAGE (Grid No. 1) .....	-200	max.	Volts
D-C PLATE CURRENT .....	40	max.	Milliamperes
PLATE INPUT .....	16	max.	Watts
SUPPRESSOR INPUT .....	5	max.	Watts
SCREEN INPUT .....	5	max.	Watts
PLATE DISSIPATION .....	12	max.	Watts

#### TYPICAL OPERATION:

D-C Plate Voltage .....	400	500	500	Volts
D-C Suppressor Voltage .....	0	0	40	Volts
D-C Screen Voltage .....	200	200	200	Volts
D-C Grid Voltage .....	-50	-45	-43	Volts
Peak R-F Grid Voltage .....	58	48	44	Volts
Peak A-F Grid Voltage .....	25	20	18	Volts
Internal Shield .....	Connected to cathode at socket			
D-C Plate Current .....	35	30	30	Milliamperes
D-C Screen Current .....	9	7	6	Milliamperes
D-C Grid Current (Approx.) .....	1	0	0	Milliamperes
Driving Power (Approx.)† .....	0.5	0.2	0.15	Watts
Power Output (Approx.) .....	4	5	5.5	Watts

### As Plate-Modulated R-F Power Amplifier—Class C Telephony

Carrier conditions per tube for use with a max. modulation factor of 1.0

	Pentode Connection	Tetrode Connection	
D-C PLATE VOLTAGE .....	400 max.	400 max.	Volts
D-C SUPPRESSOR VOLTAGE (Grid No. 3) .....	200 max.	—	Volts
D-C SCREEN VOLTAGE*** .....	200 max.	200 max.	Volts
D-C GRID VOLTAGE (Grid No. 1) .....	-200 max.	-200 max.	Volts
D-C PLATE CURRENT .....	50 max.	50 max.	Milliamperes
D-C GRID CURRENT .....	8 max.	8 max.	Milliamperes
PLATE INPUT .....	20 max.	20 max.	Watts
SCREEN INPUT*** .....	5 max.	7.5 max.	Watts
SUPPRESSOR INPUT .....	5 max.	—	Watts
PLATE DISSIPATION .....	8 max.	8 max.	Watts
<b>TYPICAL OPERATION:</b>			
D-C Plate Voltage .....	400	400	Volts
D-C Suppressor Voltage .....	40	—	Volts
D-C Screen Voltage*** .....	140	100	Volts

\*\*\*, †: see end of tabulation.

D-C Grid Voltage .....	-40	-70	Volts
Peak R-F Grid Voltage .....	60	100	Volts
Internal Shield .....	Connected to cathode at socket		
D-C Plate Current .....	45	45	Milliamperes
D-C Screen Current .....	20	30	Milliamperes
D-C Grid Current (Approx.) .....	5	7	Milliamperes
Screen Resistor .....	13000†	10000**	Ohms
Grid Resistor .....	8000	10000	Ohms
Driving Power (Approx.) .....	0.3	0.7	Watts
Power Output (Approx.) .....	11	11	Watts

### As R-F Power Amplifier and Oscillator—Class C Telegraphy

Key-down conditions per tube without modulation††

	Pentode Connection	Tetrode Connection	
D-C PLATE VOLTAGE .....	500 max.	500 max.	Volts
D-C SUPP. VOLT. (Grid No. 3) .....	200 max.	—	Volts
D-C SCREEN VOLTAGE*** .....	200 max.	200 max.	Volts
D-C GRID VOLT. (Grid No. 1).....	-200 max.	-200 max.	Volts
D-C PLATE CURRENT .....	80 max.	80 max.	Milliamperes
D-C GRID CURRENT .....	8 max.	8 max.	Milliamperes
PLATE INPUT .....	32 max.	32 max.	Watts
SUPPRESSOR INPUT .....	5 max.	—	Watts
SCREEN INPUT*** .....	8 max.	8 max.	Watts
PLATE DISSIPATION .....	12 max.	12 max.	Watts

#### TYPICAL OPERATION:

D-C Plate Voltage .....	500	500	400	500	Volts
D-C Suppressor Voltage .....	0	40	—	—	Volts
D-C Screen Voltage*** .....	200	200	110	80	Volts
D-C Grid Voltage .....	-85	-75	-70	-70	Volts
Peak R-F Grid Voltage .....	120	100	115	110	Volts
Internal Shield .....	Connected to cathode at socket				
D-C Plate Current .....	60	60	70	60	Milliamperes
D-C Screen Current .....	30	15	25	15	Milliamperes
D-C Grid Current (Approx.) .....	8	4	8	8	Milliamperes
Screen Resistor .....	10000	20000	11600	28000	Ohms
Grid Resistor .....	10600	18700	8700	8700	Ohms
Driving Power (Approx.).....	0.8	0.4	0.75	0.7	Watt
Power Output (Approx.) .....	20	22	18	20	Watts

† At crest of audio-frequency cycle with modulation factor of 1.0.

\*\* Connected to unmodulated plate-voltage supply.

\*\*\* For pentode connection, Grid No. 2 is screen; for tetrode connection, grids No. 2 and 3 connected together.

‡ Connected to modulated plate-voltage supply.

†† Modulation essentially negative may be used if the positive peak of the audio-frequency envelope does not exceed 115% of the carrier conditions.

## INSTALLATION AND APPLICATION

The 12.6-volt heater of the 837 may be operated from either an a-c or a d-c supply. It is designed to operate under normal conditions of line-voltage or battery-voltage variation. Other installation requirements are the same as for the 802.

For high-frequency operation above 20 megacycles, see page 144.

For additional information, see chapters on INSTALLATION and APPLICATION.

AVERAGE PLATE CHARACTERISTICS

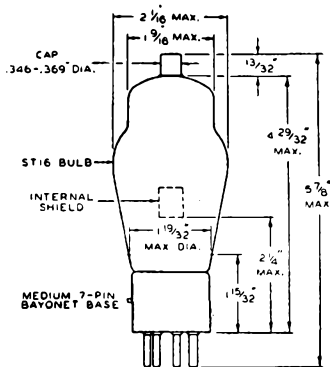
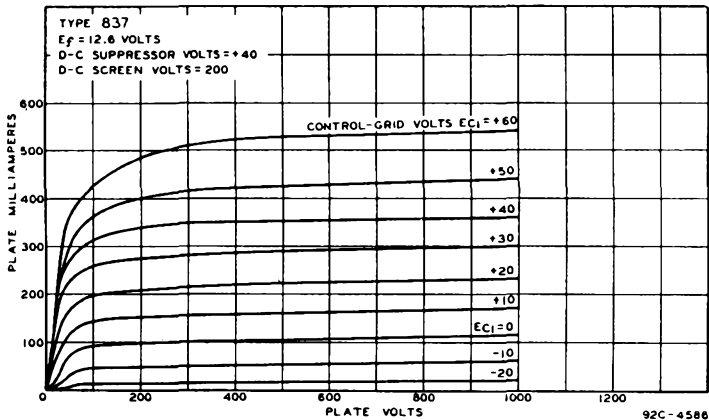

Top View of Socket Connections

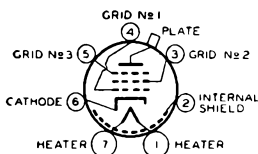

# RCA-838

## R-F Power Amplifier, Oscillator, Class B Modulator

Illustrated on page 62

RCA-838 is a three-electrode transmitting tube of the thoriated-tungsten filament type designed primarily for use as a zero-bias class B audio-frequency power amplifier. The grid is constructed so that the amplification factor of the tube varies with the amplitude of the input signal. This feature makes possible the design of class B a-f amplifiers to give high output with low distortion. In class B audio service, two tubes of this type are capable of giving an output of 260 watts with less than 5% distortion. The 838 may also be used as a radio-frequency power amplifier and oscillator at maximum ratings at frequencies as high as 30 megacycles. The maximum plate dissipation of the RCA-838 is 100 watts for class C telegraph and class B services.

### CHARACTERISTICS

Filament Volts (a-c or d-c).....	10.0	Grid-Plate Capacitance .....	8 $\mu\text{f}$
Filament Amperes .....	3.25	Grid-Filament Capacitance .....	6.5 $\mu\text{f}$
		Plate-Filament Capacitance .....	5 $\mu\text{f}$

### MAXIMUM RATINGS AND TYPICAL OPERATING CONDITIONS

#### As A-F Power Amplifier and Modulator—Class B

D-C PLATE VOLTAGE .....	1250	max. Volts
MAX.-SIGNAL D-C PLATE CURRENT* .....	175	max. Milliamperes
MAX.-SIGNAL PLATE INPUT* .....	220	max. Watts
PLATE DISSIPATION* .....	100	max. Watts

#### TYPICAL OPERATION:

Unless otherwise specified, values are for 2 tubes

D-C Plate Voltage .....	1000	1250	Volts
D-C Grid Voltage <sup>§</sup> .....	0	0	Volts
Peak A-F Grid-to-Grid Voltage .....	200	200	Volts
Zero-Sig. D-C Plate Current .....	106	148	Milliamperes
Max.-Sig. D-C Plate Current .....	320	320	Milliamperes
Load Resistance (Per tube) .....	1725	2250	Ohms
Effective Load Resistance (Plate-to-plate) .....	6900	9000	Ohms
Max.-Signal Driving Power (Approx.) .....	7	7.5	Watts
Max.-Signal Power Output (Approx.) <sup>‡</sup> .....	200	260	Watts

#### As R-F Power Amplifier—Class B Telephony

Carrier conditions per tube for use with a max. modulation factor of 1.0

D-C PLATE VOLTAGE .....	1250	max. Volts
D-C PLATE CURRENT .....	150	max. Milliamperes
PLATE INPUT .....	150	max. Watts
PLATE DISSIPATION .....	100	max. Watts

#### TYPICAL OPERATION:

D-C Plate Voltage .....	1000	1250	Volts
D-C Grid Voltage <sup>§</sup> .....	0	0	Volts
Peak R-F Grid Voltage .....	70	60	Volts
D-C Plate Current .....	130	106	Milliamperes
D-C Grid Current (Approx.) .....	15	15	Milliamperes
Driving Power (Approx.) <sup>†</sup> .....	8	6	Watts
Power Output (Approx.) .....	40	42.5	Watts

\* , § , † , ‡: see next page.

### As Plate-Modulated R-F Power Amplifier—Class C Telephony

Carrier conditions per tube for use with a max. modulation factor of 1.0

D-C PLATE VOLTAGE .....	1000	max.	Volts
D-C GRID VOLTAGE .....	-400	max.	Volts
D-C PLATE CURRENT .....	175	max.	Milliamperes
D-C GRID CURRENT .....	70	max.	Milliamperes
PLATE INPUT .....	175	max.	Watts
PLATE DISSIPATION .....	67	max.	Watts

**TYPICAL OPERATION:**

D-C Plate Voltage .....	750	1000	Volts
D-C Grid Voltage <sup>§</sup> .....	-100	-135	Volts
Peak R-F Grid Voltage .....	220	255	Volts
D-C Plate Current .....	150	150	Milliamperes
D-C Grid Current (Approx.) .....	60	60	Milliamperes
Grid Resistor .....	1670	2250	Ohms
Driving Power (Approx.) .....	14	16	Watts
Power Output (Approx.) .....	65	100	Watts

### As R-F Power Amplifier and Oscillator—Class C Telegraphy

Key-down conditions per tube without modulation<sup>††</sup>

D-C PLATE VOLTAGE .....	1250	max.	Volts
D-C GRID VOLTAGE .....	-400	max.	Volts
D-C PLATE CURRENT .....	175	max.	Milliamperes
D-C GRID CURRENT .....	70	max.	Milliamperes
PLATE INPUT .....	220	max.	Watts
PLATE DISSIPATION .....	100	max.	Watts

**TYPICAL OPERATION:**

D-C Plate Voltage .....	750	1000	1250	Volts
D-C Grid Voltage <sup>§</sup> .....	-80	-85	-90	Volts
Peak R-F Grid Voltage .....	190	195	200	Volts
D-C Plate Current .....	150	150	150	Milliamperes
D-C Grid Current (Approx.) .....	30	30	30	Milliamperes
Grid Resistor .....	2670	2835	3000	Ohms
Driving Power (Approx.) .....	6	6	6	Watts
Power Output (Approx.) .....	65	100	130	Watts

\* Averaged over any audio-frequency cycle of sine-wave form.

† Approximately 4% harmonic distortion.

§ Grid voltages are given with respect to the mid-point of filament operated on a.c. When a.c. is used, the circuit returns are made to the mid-point of the filament circuit. When a d-c supply is used, the returns are made to the negative filament terminal.

†† Modulation essentially negative may be used if the positive peak of the audio-frequency envelope does not exceed 115% of the carrier conditions.

† At crest of audio-frequency cycle with modulation factor of 1.0.

## INSTALLATION AND APPLICATION

For installation and outline drawing, refer to type 203-A.

In special cases when the 838 is operated as a class B a-f amplifier and it is desirable to keep the a-f distortion to a value lower than 4%, the use of a small amount of grid-bias voltage is advantageous. Typical operating conditions are approximately the same as those for zero-bias operation. With a plate-supply voltage of 1250 volts, the exceptions are: grid-bias voltage, -15 volts; peak a-f grid-to-grid voltage, 210 volts; and zero-signal d-c plate current, 50 milliamperes (2 tubes).

For high-frequency operation above 30 megacycles, refer to page 144.

For additional information, see chapters on INSTALLATION and APPLICATION.

Refer to type 805 for a plate family of average characteristics which also applies to this type.

Top View of Socket Connections

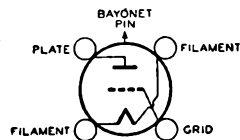

# RCA-841

## R-F Power Amplifier, Oscillator, Class B Modulator

RCA-841 is a high- $\mu$ , three-electrode tube of the thoriated-tungsten filament type. As a radio-frequency power amplifier it may be operated under maximum rated conditions at frequencies as high as 6 megacycles. For socket and outline drawing, refer to RCA-1602.

### CHARACTERISTICS

Filament Volts (a-c or d-c) .....	7.5	Grid-Plate Capacitance .....	7 $\mu\mu\text{f}$
Filament Amperes .....	1.25	Grid-Filament Capacitance .....	4 $\mu\mu\text{f}$
Amplification Factor .....	30	Plate-Filament Capacitance .....	3 $\mu\mu\text{f}$

### MAXIMUM RATINGS

	Class B Modu- lation	Class B Tele- phony*	Class C Tele- phony*	Class C Tele- graphy <sup>§</sup>	
D-C PLATE VOLTAGE .....	425	450	350	450	Volts
D-C GRID VOLTAGE .....	—	—	-200	-200	Volts
D-C PLATE CURRENT .....	—	50	60	60	Milliamperes
MAX.-SIG. D-C PLATE CUR. <sup>†</sup>	60	—	—	—	Milliamperes
D-C GRID CURRENT .....	—	—	20	20	Milliamperes
PLATE INPUT .....	—	22.5	21	27	Watts
MAX.-SIG. PLATE INPUT <sup>†</sup> .....	25	—	—	—	Watts
PLATE DISSIPATION .....	15 <sup>†</sup>	15	10	15	Watts

# RCA-842

## A-F Power Amplifier, Modulator

RCA-842 is a low- $\mu$ , three-electrode tube of the thoriated-tungsten filament type for use primarily as a class A power amplifier. For socket and outline drawing, refer to RCA-1602.

### CHARACTERISTICS

Filament Volts (a-c or d-c) .....	7.5	Grid-Plate Capacitance .....	7 $\mu\mu\text{f}$
Filament Amperes .....	1.25	Grid-Filament Capacitance .....	4 $\mu\mu\text{f}$
Amplification Factor .....	3	Plate-Filament Capacitance .....	3 $\mu\mu\text{f}$

### MAXIMUM RATINGS FOR CLASS A SERVICE

D-C PLATE VOLTAGE .....	425	Volts
PLATE DISSIPATION .....	12	Watts

With a plate voltage of 425 volts, a grid bias of -100 volts, and a load resistance of 8000 ohms, the 842 is capable of giving an undistorted power output of 3 watts.

# RCA-843

## R-F Power Amplifier, Oscillator

RCA-843 is a three-electrode tube of the heater-cathode type for use as an oscillator and r-f power amplifier. The 843 may be operated at maximum input at frequencies as high as 6 megacycles.

### CHARACTERISTICS

Heater Volts (a-c or d-c) .....	2.5	Grid-Plate Capacitance .....	4.5 $\mu\mu\text{f}$
Heater Amperes .....	2.5	Grid-Cathode Capacitance .....	4 $\mu\mu\text{f}$
Amplification Factor .....	7.7	Plate-Cathode Capacitance .....	4 $\mu\mu\text{f}$
Maximum Overall Length .....	5 $\frac{5}{8}$ "	Bulb .....	S-17
Maximum Diameter .....	2 $\frac{1}{8}$ "	Base .....	Medium 5-Pin

†, \*, §: see next page.



MAXIMUM RATINGS

	Class B Tele- phony*	Class C Tele- phony*	Class C Tele- graphy§	
D-C PLATE VOLTAGE .....	450	350	450	Volts
D-C GRID VOLTAGE .....	—	-200	-200	Volts
D-C PLATE CURRENT .....	30	40	40	Milliamperes
D-C GRID CURRENT .....	—	7.5	7.5	Milliamperes
PLATE INPUT .....	—	14	18	Watts
PLATE DISSIPATION .....	15	10	15	Watts

RCA-844

Screen-Grid R-F Power Amplifier

RCA-844 is a screen-grid transmitting tube of the heater-cathode type for use as a radio-frequency amplifier and multiplier. The 844 may be operated at maximum rated conditions at frequencies as high as 8 megacycles.

CHARACTERISTICS

Heater Volts (a-c or d-c) .....	2.5	Grid-Plate Capacitance (With external shielding) .....	0.15 max. $\mu\text{mf}$
Heater Amperes .....	2.5	Input Capacitance .....	9.5 $\mu\text{mf}$
Amplification Factor .....	75	Output Capacitance .....	7.5 $\mu\text{mf}$
Transconductance (For plate current of 13 ma.) Micromhos .....	600	Bulb .....	ST-16
Maximum Overall Length .....	5 $\frac{3}{8}$ "	Cap .....	Medium Metal
Maximum Diameter .....	2 $\frac{1}{8}$ "	Base .....	Medium 5-Pin

MAXIMUM RATINGS

	Class B Tele- phony*	Class C Tele- phony*	Class C Tele- graphy§	
D-C PLATE VOLTAGE .....	500	500	500	Volts
D-C SCREEN VOLTAGE.....	175	175	175	Volts
D-C GRID VOLTAGE .....	—	-200	-200	Volts
D-C PLATE CURRENT .....	25	25	30	Milliamperes
D-C GRID CURRENT .....	—	5	5	Milliamperes
SCREEN INPUT .....	3	2	3	Watts
PLATE DISSIPATION .....	15	10	15	Watts

\* Carrier conditions per tube for use with a max. modulation factor of 1.0.

§ Key-down conditions per tube without modulation. Modulation essentially negative may be used if the positive peak of the audio-frequency envelope does not exceed 115% of the carrier conditions.

† Averaged over any audio-frequency cycle of sine-wave form.

INSTALLATION AND APPLICATION

The plate of the 841, 842, 843, or 844 shows no color at the maximum plate-dissipation rating for each class of service.

For high-frequency operation of the 841, 843, and 844, see page 144.

Top Views of Socket Connections

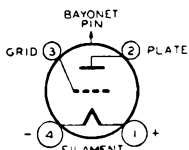

RCA-841 and 842

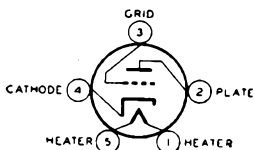

RCA-843

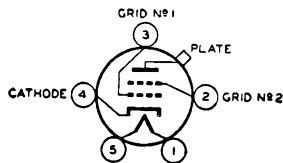

RCA-844

# RCA-845

## A-F Power Amplifier, Modulator

For illustration, refer to 838 on page 62

RCA-845 is a three-electrode power amplifier tube of the thoriated-tungsten filament type. It has a maximum plate dissipation rating of 75 watts, for class A modulator and a-f amplifier service. In class AB modulator and a-f amplifier service two 845's are capable of delivering over 100 watts of audio power.

### CHARACTERISTICS

Filament Volts (a-c or d-c) .....	10.0	Grid-Plate Capacitance .....	13.5 $\mu\text{f}$
Filament Amperes .....	3.25	Grid-Filament Capacitance .....	6 $\mu\text{f}$
Amplification Factor .....	5.3	Plate-Filament Capacitance .....	6.5 $\mu\text{f}$

### MAXIMUM RATINGS AND TYPICAL OPERATING CONDITIONS

#### As A-F Power Amplifier and Modulator—Class A

D-C PLATE VOLTAGE .....	1250 max.	Volts
PLATE DISSIPATION .....	75 max.	Watts

#### TYPICAL OPERATION AND CHARACTERISTICS:

D-C Plate Voltage .....	750	1000	1250	Volts
D-C Grid Voltage <sup>§</sup> .....	-98	-155	-209	Volts
Peak A-F Grid Voltage .....	93	150	204	Volts
D-C Plate Current .....	95	65	52	Milliamperes
Transconductance .....	3100	2800	2500	Micromhos
Plate Resistance .....	1700	1900	2100	Ohms
Load Resistance .....	3400	9000	16000	Ohms
Cathode Resistor .....	1030	2385	4020	Ohms
Undistorted Power Output .....	15	21	24	Watts

#### As A-F Power Amplifier and Modulator—Class AB $\diamond$

D-C PLATE VOLTAGE .....	1250 max.	Volts
D-C GRID VOLTAGE .....	-400 max.	Volts
D-C PLATE CURRENT .....	120 max.	Milliamperes
PLATE INPUT .....	130 max.	Watts
PLATE DISSIPATION .....	75 max.	Watts

#### TYPICAL OPERATION:

Unless otherwise specified, values are for 2 tubes

D-C Plate Voltage .....	1000	1250	Volts
D-C Grid Voltage <sup>§</sup> .....	-175	-225	Volts
Peak A-F Grid-to-Grid Voltage .....	340	440	Volts
Zero-Sig. D-C Plate Current .....	40	40	Milliamperes
Max.-Sig. D-C Plate Current .....	220	200	Milliamperes
Load Resistance (Per tube) .....	1150	2200	Ohms
Effective Load Res. (Plate-to-plate) .....	4600	8800	Ohms
Max.-Sig. Power Output (Approx.) .....	75	105	Watts

<sup>§</sup> Grid voltages are given with respect to the mid-point of filament operated on a.c. If d.c. is used, each stated value of grid voltage should be decreased by 7 volts and the circuit returns made to the negative end of the filament.

$\diamond$  No grid current flows during most positive swing of input signal.

## INSTALLATION AND APPLICATION

The base pins of the RCA-845 fit the standard four-contact socket, such as the RCA type UT-541A. The socket should be installed so that the tube will operate in a vertical position with the base down.

In cases where the input circuit of the 845 is resistance-coupled or impedance-coupled, the resistance in the grid circuit should not be made too high. A resistance value of 0.5 megohm is recommended when one 845 is used with cathode bias; without cathode bias, the grid resistance should not exceed 0.1 megohm.

In push-pull class AB amplifier service, each 845 should be provided with individual adjustment of grid-bias voltage. Each bias supply should be by-passed by a suitable condenser to minimize degenerative effects.

The plate of the 845 shows no color at the maximum plate-dissipation rating for each class of service.

For additional information, see chapters on INSTALLATION and APPLICATION.

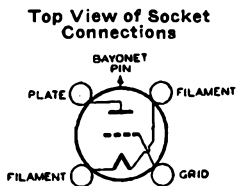
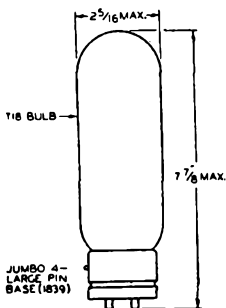
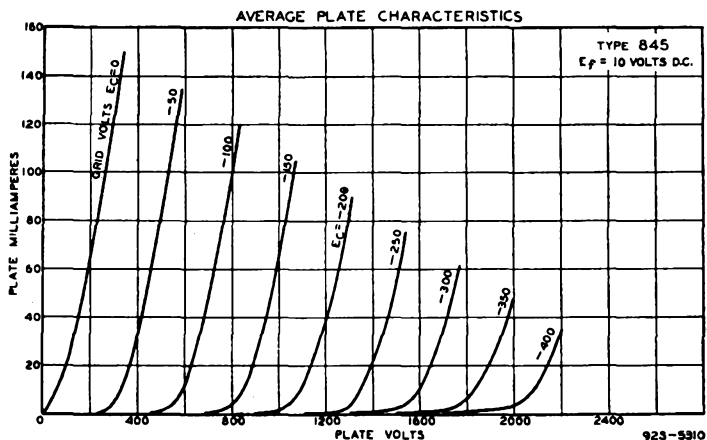

# RCA-849

## R-F and A-F Power Amplifier, Oscillator, Modulator

Illustrated on page 35

RCA-849 is a three-electrode transmitting tube of the thoriated tungsten filament type for use as a class A and class B audio-frequency power amplifier, modulator, radio-frequency amplifier and oscillator. Two tubes operated as a class B modulator or a-f amplifier are capable of delivering an audio-frequency power output of 1100 watts. As an r-f power amplifier and oscillator, the 849 can be operated under maximum rated conditions at frequencies as high as 3 megacycles.

### CHARACTERISTICS

Filament Volts (a-c or d-c) .....	11.0	Grid-Plate Capacitance .....	33.5 $\mu\mu\text{f}$
Filament Amperes .....	5	Grid-Filament Capacitance .....	17 $\mu\mu\text{f}$
Amplification Factor .....	19	Plate-Filament Capacitance .....	3 $\mu\mu\text{f}$

### MAXIMUM RATINGS AND TYPICAL OPERATING CONDITIONS

#### As A-F Power Amplifier and Modulator—Class A

D-C PLATE VOLTAGE .....	3000 max.	Volts
PLATE DISSIPATION .....	300 max.	Watts

#### TYPICAL OPERATION:

D-C Plate Voltage .....	2000	2500	3000	Volts
D-C Grid Voltage <sup>§</sup> .....	-74	-104	-132	Volts
Peak A-F Grid Voltage .....	68	98	126	Volts
D-C Plate Current .....	135	110	100	Milliamperes
Plate Resistance .....	2950	3150	3250	Ohms
Load Resistance .....	6000	12000	18000	Ohms
Cathode-Bias Resistor .....	550	950	1320	Ohms
Undistorted Power Output .....	58	81	100	Watts

#### As A-F Power Amplifier and Modulator—Class B

D-C PLATE VOLTAGE .....	3000 max.	Volts
MAX.-SIGNAL D-C PLATE CURRENT* .....	350 max.	Milliamperes
MAX.-SIGNAL PLATE INPUT* .....	825 max.	Watts
PLATE DISSIPATION* .....	300 max.	Watts

#### TYPICAL OPERATION:

*Unless otherwise specified, values are for 2 tubes*

D-C Plate Voltage .....	2000	2500	3000	Volts
D-C Grid Voltage <sup>§</sup> .....	-105	-130	-155	Volts
Peak A-F Grid-to-Grid Voltage .....	450	480	500	Volts
Zero-Sig. D-C Plate Current .....	14	20	24	Milliamperes
Max.-Sig. D-C Plate Current .....	650	560	520	Milliamperes
Load Resistance (Per tube) .....	1600	2600	3200	Ohms
Effective Load Res. (Plate-to-plate) .....	6400	10400	12800	Ohms
Max.-Sig. Driving Power (Approx.) .....	16	14	12	Watts
Max.-Sig Power Output (Approx.) .....	900	1000	1100	Watts

§, \*: see next page.

### As R-F Power Amplifier—Class B Telephony

Carrier conditions per tube for use with a max. modulation factor of 1.0

D-C PLATE VOLTAGE .....	2500	max.	Volts
D-C PLATE CURRENT .....	350	max.	Milliamperes
PLATE INPUT .....	600	max.	Watts
PLATE DISSIPATION .....	400	max.	Watts

**TYPICAL OPERATION:**

D-C Plate Voltage .....	1500	2000	2500	Volts
D-C Grid Voltage§ .....	-70	-95	-125	Volts
Peak R-F Grid Voltage .....	140	140	140	Volts
D-C Plate Current .....	320	265	216	Milliamperes
D-C Grid Current .....	5	3	1	Milliamperes
Driving Power (Approx.)† .....	18	15	12	Watts
Power Output (Approx.) .....	150	170	180	Watts

### As Plate-Modulated R-F Power Amplifier—Class C Telephony

Carrier conditions per tube for use with a max. modulation factor of 1.0

D-C PLATE VOLTAGE .....	2000	max.	Volts
D-C GRID VOLTAGE .....	-500	max.	Volts
D-C PLATE CURRENT .....	350	max.	Milliamperes
D-C GRID CURRENT .....	125	max.	Milliamperes
PLATE INPUT .....	700	max.	Watts
PLATE DISSIPATION .....	270	max.	Watts

**TYPICAL OPERATION:**

D-C Plate Voltage .....	1500	2000	Volts
D-C Grid Voltage .....	-250	-300	Volts
Peak R-F Grid Voltage .....	400	450	Volts
D-C Plate Current .....	300	300	Milliamperes
D-C Grid Current (Approx.) .....	35	30	Milliamperes
Grid Resistor .....	7140	10000	Ohms
Driving Power (Approx.) .....	14	14	Watts
Power Output (Approx.) .....	300	425	Watts

### As R-F Power Amplifier and Oscillator—Class C Telegraphy

Key-down conditions per tube without modulation††

D-C PLATE VOLTAGE .....	2500	max.	Volts
D-C GRID VOLTAGE .....	-500	max.	Volts
D-C PLATE CURRENT .....	350	max.	Milliamperes
D-C GRID CURRENT .....	125	max.	Milliamperes
PLATE INPUT .....	875	max.	Watts
PLATE DISSIPATION .....	400	max.	Watts

**TYPICAL OPERATION:**

D-C Plate Voltage .....	1500	2000	2500	Volts
D-C Grid Voltage .....	-175	-200	-250	Volts
Peak R-F Grid Voltage .....	310	325	360	Volts
D-C Plate Current .....	300	300	300	Milliamperes
D-C Grid Current (Approx.) .....	35	25	20	Milliamperes
Grid Resistor .....	5000	8000	12500	Ohms
Driving Power (Approx.) .....	11	9	8	Watts
Power Output (Approx.) .....	300	425	560	Watts

§ Grid voltages are given with respect to the mid-point of filament operated on a.c. If d.c. is used, each stated value of grid voltage should be decreased by 8 volts and the circuit returns made to the negative end of the filament.

\* Averaged over any audio-frequency cycle of sine-wave form.

† At crest of audio-frequency cycle with modulation factor of 1.0.

†† Modulation essentially negative may be used if the positive peak of the audio-frequency envelope does not exceed 115% of the carrier conditions.

## INSTALLATION AND APPLICATION

For information on end-mounting numbers and for plate dissipation considerations, see INSTALLATION and APPLICATION for the 204-A.

When the 849 is used as a class A amplifier with the grid circuit either resistance- or impedance-coupled, the d-c resistance in the grid circuit should not be made too high. A resistance value of 0.25 megohm for one 849 is the recommended maximum when cathode bias is used; without cathode bias, the grid resistance should not exceed 25000 ohms.

For high-frequency operation above 3 megacycles, see page 144.

For additional information, see chapters on INSTALLATION and APPLICATION.

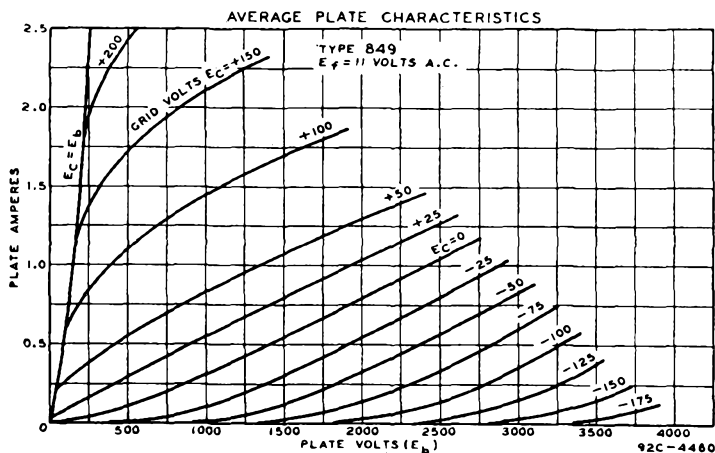

### Connections to End-Mountings

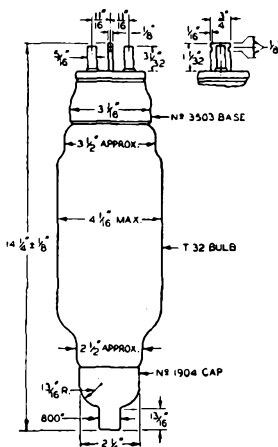
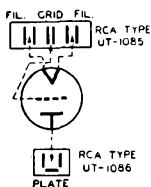

# RCA-850

## Screen-Grid R-F Power Amplifier

RCA-850 is a screen-grid transmitting tube of the thoriated-tungsten filament type for use as a radio-frequency power amplifier. The control grid is brought out through a separate seal at the top of the bulb. Neutralization to prevent feedback is generally unnecessary when the tube is used in adequately-shielded circuits. The 850 may be operated at maximum input at frequencies as high as 13 megacycles.

### CHARACTERISTICS

Filament Volts (a-c or d-c) .....	10.0	Grid-Plate Capacitance (With external shielding) .....	0.25 max. $\mu\mu\text{f}$
Filament Amperes .....	3.25	Input Capacitance .....	17 $\mu\mu\text{f}$
Amplification Factor .....	550	Output Capacitance .....	25 $\mu\mu\text{f}$
Transconductance (For plate current of 19.5 ma.) Micromhos .....	2750		

### MAXIMUM RATINGS

	Class B Tele- phony*	Class C Tele- phony*	Class C Tele- graphy <sup>‡</sup>	
D-C PLATE VOLTAGE .....	1250	1000	1250	Volts
D-C SCREEN VOLTAGE .....	400†	400	400†	Volts
D-C GRID VOLTAGE .....	—	-400	-400	Volts
D-C PLATE CURRENT .....	150	150	175	Milliamperes
D-C GRID CURRENT .....	—	40	40	Milliamperes
PLATE INPUT .....	150	150	220	Watts
SCREEN INPUT .....	10	7	10	Watts
PLATE DISSIPATION .....	100	70	100	Watts

\* Carrier conditions per tube for use with a max. modulation factor of 1.0.

‡ Key-down conditions per tube without modulation. Modulation essentially negative may be used if the positive peak of the audio-frequency envelope does not exceed 115% of the carrier conditions.

† Series-screen-resistor method not recommended.

### INSTALLATION AND APPLICATION

The base pins of the 850 fit the standard transmitting 4-contact socket, such as the RCA type UT-541A. The socket should be mounted to hold the tube in a vertical position with the base down. For outline drawing, refer to type 805.

The plate of the 850 shows only a barely perceptible red color at the maximum plate-dissipation rating for each class of service. The screen should never be allowed to show more than a dull red color.

For high-frequency operation above 13 megacycles, see page 144.

When the screen voltage is obtained from a series screen resistor, the value of the resistor should be not less than 15000 ohms for a plate-supply voltage of 750 volts and 25000 ohms for 1000 volts.

For additional information, see chapters on INSTALLATION and APPLICATION.

Top View of Socket Connections

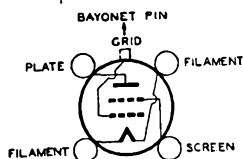

# RCA-851

## R-F and A-F Power Amplifier, Oscillator, Modulator

RCA-851 is a three-electrode transmitting tube of the thoriated-tungsten filament type for use as an oscillator, radio-, and audio-frequency power amplifier. The grid and plate leads are brought out at opposite ends of the tube to insure good insulation. As an r-f power amplifier and oscillator, the 851 can be operated under maximum rated conditions at frequencies as high as 3 megacycles.

### CHARACTERISTICS

Filament Volts (a-c or d-c) .....	11.0	Grid-Plate Capacitance .....	47 $\mu\mu\text{f}$
Filament Amperes .....	15.5	Grid-Filament Capacitance .....	25.5 $\mu\mu\text{f}$
Amplification Factor .....	20.5	Plate-Filament Capacitance .....	4.5 $\mu\mu\text{f}$

### MAXIMUM RATINGS

#### As A-F Power Amplifier and Modulator

	Class A	Class B	
D-C PLATE VOLTAGE .....	2500	3000	Volts
MAX.-SIGNAL D-C PLATE CURRENT† .....	—	1.0	Ampere
MAX.-SIGNAL PLATE INPUT† .....	—	2250	Watts
PLATE DISSIPATION .....	600	750†	Watts

#### As R-F Power Amplifier

	Class B Tele- phony*	Class C Tele- phony*	Class C Tele- graphy‡	
D-C PLATE VOLTAGE .....	2500	2000	2500	Volts
D-C GRID VOLTAGE .....	—	-500	-500	Volts
D-C PLATE CURRENT .....	0.75	1.0	1.0	Ampere
D-C GRID CURRENT .....	—	200	200	Milliamperes
PLATE INPUT .....	1100	1800	2500	Watts
PLATE DISSIPATION .....	750	500	750	Watts

† Averaged over any audio-frequency cycle of sine-wave form.

\* Carrier conditions per tube for use with a max. modulation factor of 1.0.

‡ Key-down conditions per tube without modulation. Modulation essentially negative may be used if the positive peak of the audio-frequency envelope does not exceed 115% of the carrier conditions.

### INSTALLATION AND APPLICATION

For information on end-mountings and for plate dissipation considerations, see INSTALLATION and APPLICATION for the 204-A.

When the 851 is used as a class A amplifier with the grid circuit either resistance or impedance coupled, the d-c resistance in the grid circuit should not be made too high. A resistance value of 100,000 ohms for one 851 is the recommended maximum when cathode bias is used; without cathode bias, the grid resistance should not exceed 10,000 ohms.

For high-frequency operation above 3 megacycles, see page 144.

For additional information, see chapters on INSTALLATION and APPLICATION.

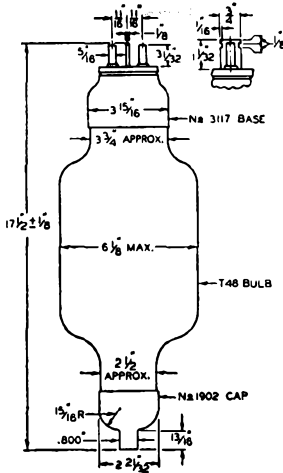

#### Connections to End-Mountings

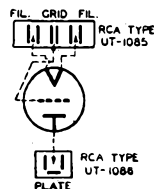



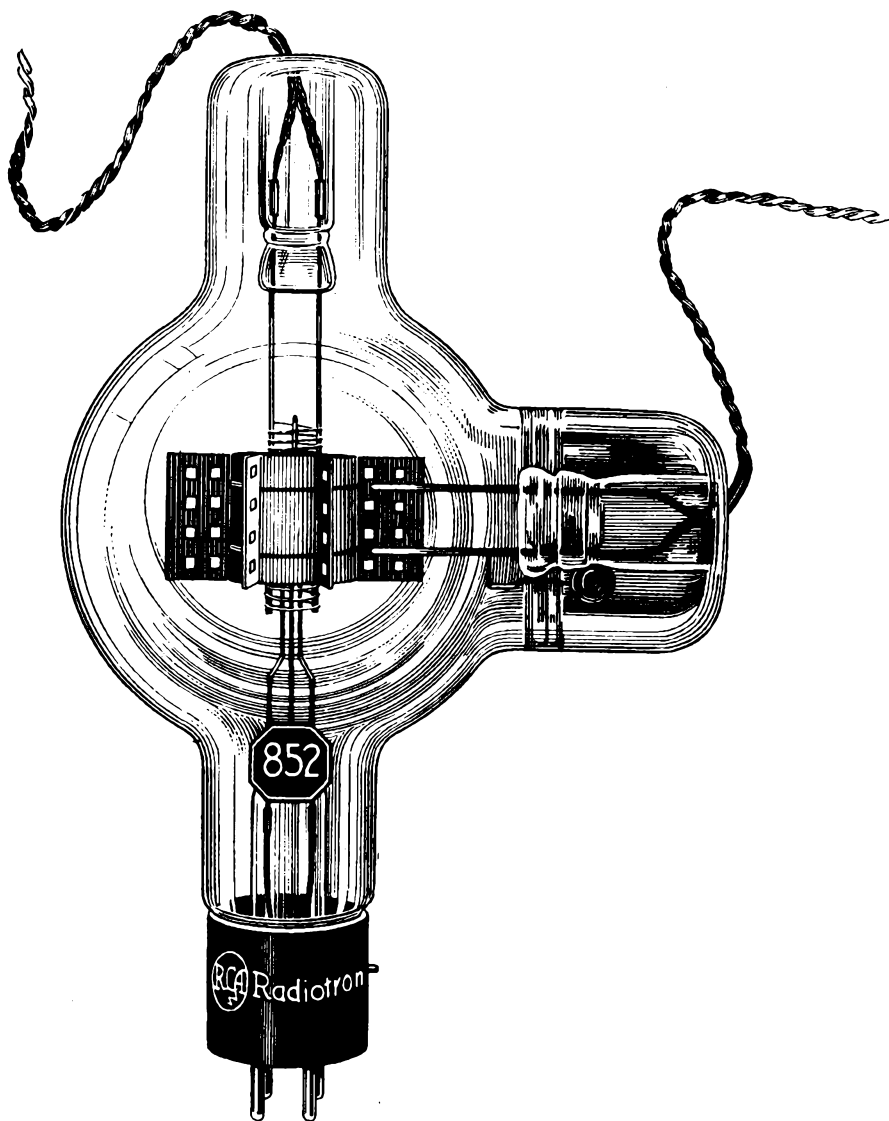

### RCA-852

The original high-frequency tube—continuously improved, it is the favorite of many tube users.

# RCA-852

## R-F Power Amplifier, Oscillator

RCA-852 is a three-electrode transmitting tube of the thoriated-tungsten filament type for use as an r-f power amplifier or oscillator. Each electrode lead is brought out of the bulb through a separate seal. This construction insures good insulation and low interelectrode capacitances. The 852 can be operated at maximum ratings at frequencies as high as 30 megacycles.

### CHARACTERISTICS

Filament Volts (a-c or d-c) .....	10.0	Grid-Plate Capacitance .....	2.6 $\mu\text{f}$
Filament Amperes .....	3.25	Grid-Filament Capacitance .....	1.9 $\mu\text{f}$
Amplification Factor .....	12	Plate-Filament Capacitance .....	1.0 $\mu\text{f}$

### MAXIMUM RATINGS AND TYPICAL OPERATING CONDITIONS

#### As R-F Power Amplifier—Class B Telephony

*Carrier conditions per tube for use with a max. modulation factor of 1.0*

D-C PLATE VOLTAGE .....	3000 max.	Volts
D-C PLATE CURRENT .....	85 max.	Milliamperes
PLATE INPUT .....	150 max.	Watts
PLATE DISSIPATION .....	100 max.	Watts

#### TYPICAL OPERATION:

D-C Plate Voltage .....	2000	3000	Volts
D-C Grid Voltage <sup>§</sup> .....	-155	-250	Volts
Peak R-F Grid Voltage .....	200	225	Volts
D-C Plate Current .....	60	43	Milliamperes
D-C Grid Current (Approx.) .....	1	0	Milliamperes
Driving Power (Approx.) <sup>†</sup> .....	10	7	Watts
Power Output (Approx.) .....	30	40	Watts

#### As Plate-Modulated R-F Power Amplifier—Class C Telephony

*Carrier conditions per tube for use with a max. modulation factor of 1.0*

D-C PLATE VOLTAGE .....	2000 max.	Volts
D-C GRID VOLTAGE .....	-1000 max.	Volts
D-C PLATE CURRENT .....	85 max.	Milliamperes
D-C GRID CURRENT .....	40 max.	Milliamperes
PLATE INPUT .....	170 max.	Watts
PLATE DISSIPATION .....	67 max.	Watts

#### TYPICAL OPERATION:

D-C Plate Voltage .....	1500	2000	Volts
D-C Grid Voltage <sup>§</sup> .....	-400	-500	Volts
Peak R-F Grid Voltage .....	650	750	Volts
D-C Plate Current .....	70	67	Milliamperes
D-C Grid Current (Approx.) .....	30	30	Milliamperes
Grid Resistor .....	13400	16700	Ohms
Driving Power (Approx.) .....	20	23	Watts
Power Output (Approx.) .....	45	75	Watts

§, †: see next page.

## As R-F Power Amplifier and Oscillator—Class C Telegraphy

Key-down conditions per tube without modulation††

D-C PLATE VOLTAGE .....	3000 max.	Volts
D-C GRID VOLTAGE .....	-1000 max.	Volts
D-C PLATE CURRENT .....	150 max.	Milliamperes
D-C GRID CURRENT .....	40 max.	Milliamperes
PLATE INPUT .....	300 max.	Watts
PLATE DISSIPATION .....	100 max.	Watts

### TYPICAL OPERATION:

D-C Plate Voltage .....	2500	3000	Volts
D-C Grid Voltage‡ .....	-450	-600	Volts
Peak R-F Grid Voltage .....	700	850	Volts
D-C Plate Current .....	90	85	Milliamperes
D-C Grid Current (Approx.) .....	15	15	Milliamperes
Grid Resistor .....	30000	40000	Ohms
Driving Power (Approx.) .....	10	12	Watts
Power Output (Approx.) .....	135	165	Watts

† At crest of audio-frequency cycle with modulation factor of 1.0.

‡ Grid voltages are given with respect to the mid-point of filament operated on a.c. If d.c. is used, each stated value of grid voltage should be decreased by 7 volts and the circuit returns made to the negative end of the filament.

†† Modulation essentially negative may be used if the positive peak of the audio-frequency envelope does not exceed 115% of the carrier conditions.

## INSTALLATION AND APPLICATION

The base pins of the 852 fit the standard 4-contact socket, such as the RCA type UR-542A. The socket should be mounted to hold the tube in a vertical position. In order to adequately handle the large circulating r-f current in the grid and plate circuits, both stranded leads from each arm terminal of the bulb should be used. For outline drawing, refer to RCA-860.

Top View of Socket Connections

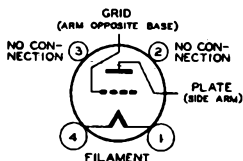

The plate of the 852 shows a dull red color at the maximum plate-dissipation rating for each class of service.

For high-frequency operation above 30 megacycles, refer to page 144.

For additional information, refer to chapters on INSTALLATION and APPLICATION.

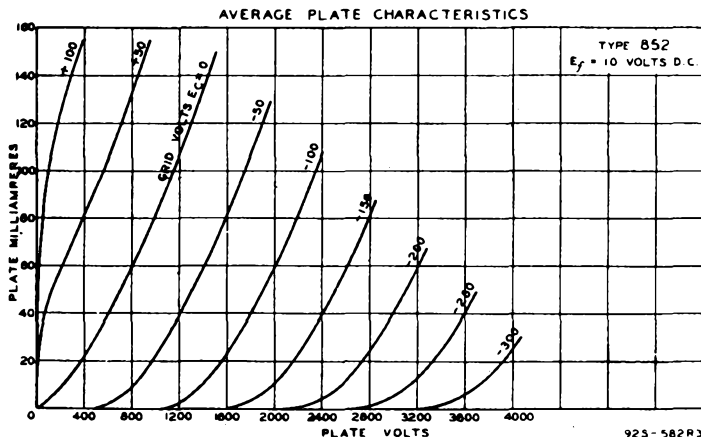

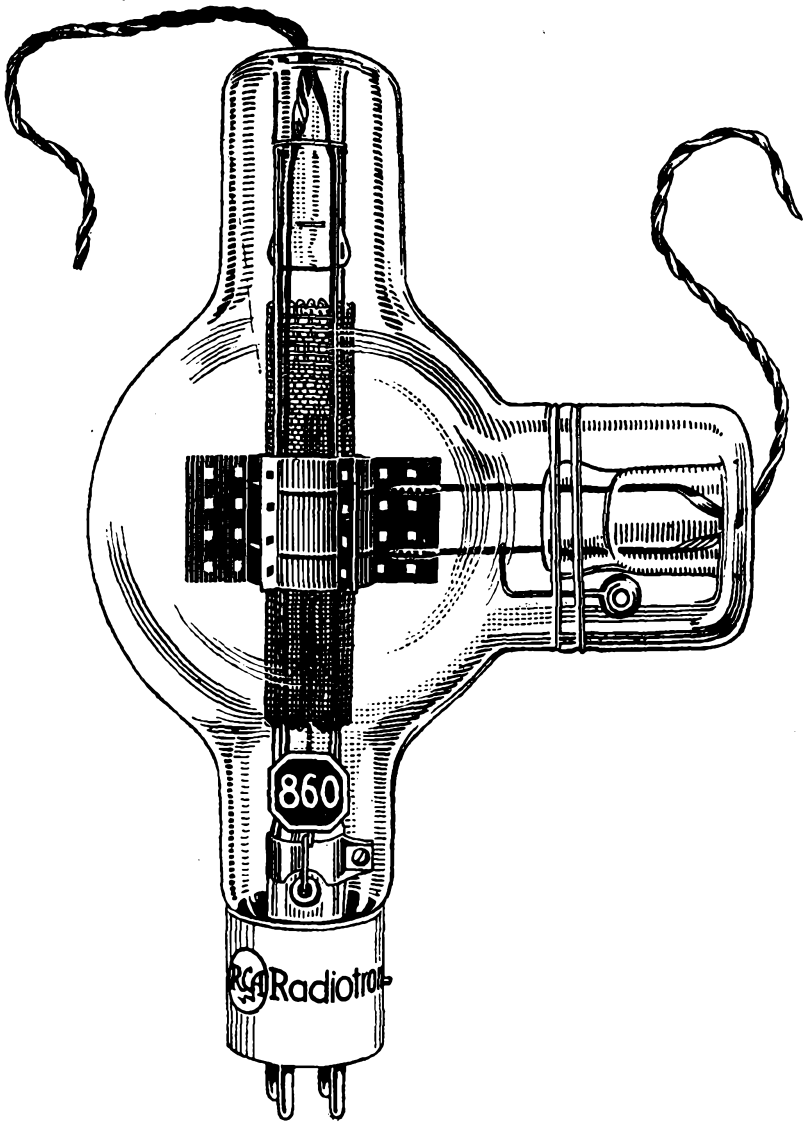

**RCA-860**

Tetrode — requiring no neutralization and being easy to drive, this type is the choice for many medium-power applications.

# RCA-860

## Screen-Grid R-F Power Amplifier

Illustrated on page 115

RCA-860 is a screen-grid transmitting tube of the thoriated-tungsten filament type for use as a radio-frequency power amplifier. The plate, grid, and screen leads are brought out of the bulb through separate seals. This design insures good insulation and low interelectrode capacitances. Neutralization to prevent feedback is generally unnecessary when the tube is used in adequately shielded circuits. The 860 may be operated at maximum input at frequencies as high as 30 megacycles. RCA-860 has a ceramic base.

### CHARACTERISTICS

Filament Volts (a-c or d-c) .....	10.0	Grid-Plate Capacitance (With external shielding) .....	0.08 max. $\mu\text{f}$
Filament Amperes .....	3.25	Input Capacitance .....	7.75 $\mu\text{f}$
Amplification Factor (Approx.) .....	200	Output Capacitance .....	7.5 $\mu\text{f}$
Transconductance (For plate current of 50 ma.) Micromhos .....	1100		

### MAXIMUM RATINGS AND TYPICAL OPERATING CONDITIONS

#### As R-F Power Amplifier—Class B Telephony

Carrier conditions per tube for use with a max. modulation factor of 1.0

D-C PLATE VOLTAGE .....	3000 max. Volts
D-C SCREEN VOLTAGE .....	500 max. Volts
D-C PLATE CURRENT .....	85 max. Milliamperes
PLATE INPUT .....	150 max. Watts
SCREEN INPUT .....	10 max. Watts
PLATE DISSIPATION .....	100 max. Watts

#### TYPICAL OPERATION:

D-C Plate Voltage .....	2000	3000	Volts
D-C Screen Voltage .....	300	300	Volts
D-C Grid Voltage <sup>§</sup> .....	-50	-50	Volts
D-C Plate Current .....	60	43	Milliamperes
Screen Resistor .....	Not recommended		
Power Output (Approx.) .....	30	40	Watts

#### As Plate-Modulated R-F Power Amplifier—Class C Telephony

Carrier conditions per tube for use with a max. modulation factor of 1.0

D-C PLATE VOLTAGE .....	2000 max. Volts
D-C SCREEN VOLTAGE .....	500 max. Volts
D-C GRID VOLTAGE .....	-800 max. Volts
D-C PLATE CURRENT .....	85 max. Milliamperes
D-C GRID CURRENT .....	40 max. Milliamperes
PLATE INPUT .....	170 max. Watts
SCREEN INPUT .....	6.7 max. Watts
PLATE DISSIPATION .....	67 max. Watts

§: see next page.

TYPICAL OPERATION:

D-C Plate Voltage .....	1500	1800	2000	Volts
D-C Screen Voltage .....	300	300	220	Volts
D-C Grid Voltage§ .....	-225	-225	-200	Volts
Peak R-F Grid Voltage .....	—	—	500	Volts
D-C Plate Current .....	70	67	85	Milliamperes
D-C Screen Current .....	—	—	25	Milliamperes
D-C Grid Current (Approx.) .....	30	30	38	Milliamperes
Screen Resistor .....	60000	85000	100000	Ohms
Grid Resistor .....	7500	7500	5260	Ohms
Driving Power (Approx.) .....	15	15	17	Watts
Power Output (Approx.) .....	45	60	105	Watts

§: see next page.

**As R-F Power Amplifier and Oscillator—Class C Telegraphy**

*Key-down conditions per tube without modulation††*

D-C PLATE VOLTAGE .....	3000 max.	Volts
D-C SCREEN VOLTAGE .....	500 max.	Volts
D-C GRID VOLTAGE .....	-800 max.	Volts
D-C PLATE CURRENT .....	150 max.	Milliamperes
D-C GRID CURRENT .....	40 max.	Milliamperes
PLATE INPUT .....	300 max.	Watts
SCREEN INPUT .....	10 max.	Watts
PLATE DISSIPATION .....	100 max.	Watts

TYPICAL OPERATION:

D-C Plate Voltage .....	1500	2000	2500	3000	Volts
D-C Screen Voltage .....	300	300	300	300	Volts
D-C Grid Voltage§ .....	-150	-150	-150	-150	Volts
D-C Plate Current .....	90	90	90	85	Milliamperes
D-C Grid Current (Approx.) .....	15	15	15	15	Milliamperes
Screen Resistor .....	Not recommended				
Grid Resistor .....	10000	10000	10000	10000	Ohms
Driving Power (Approx.) .....	7	7	7	7	Watts
Power Output (Approx.) .....	60	100	135	165	Watts

§ Grid voltages are given with respect to the mid-point of filament operated on a.c. If d.c. is used, each stated value of grid voltage should be decreased by 7 volts and the circuit returns made to the negative end of the filament.

†† Modulation essentially negative may be used if the positive peak of the audio-frequency envelope does not exceed 115% of the carrier conditions.

**INSTALLATION AND APPLICATION**

For installation, refer to type 852.

The plate of the 860 shows a dull red color at the maximum plate-dissipation rating for each class of service. The screen should never be allowed to show more than a barely perceptible red color.

For high-frequency operation above 13 megacycles, see page 144.

For additional information, see chapters on INSTALLATION and APPLICATION.

AVERAGE PLATE CHARACTERISTICS

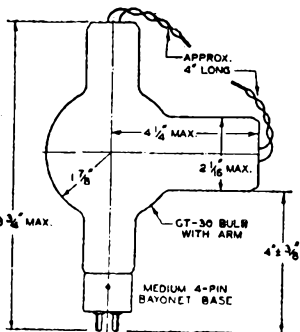
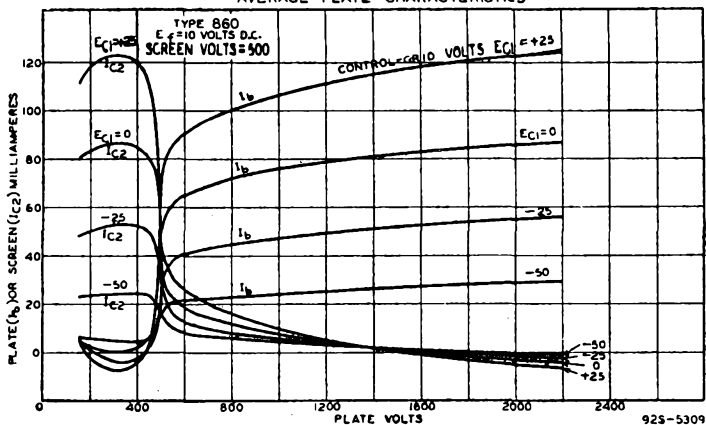

Top View of Socket Connections

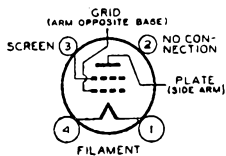

AVERAGE PLATE CHARACTERISTICS

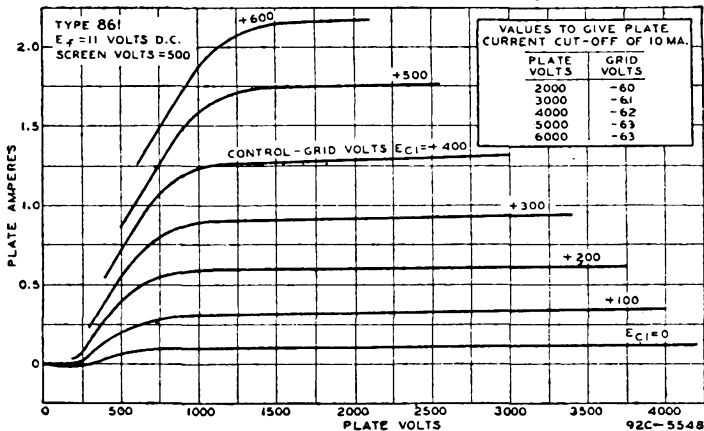

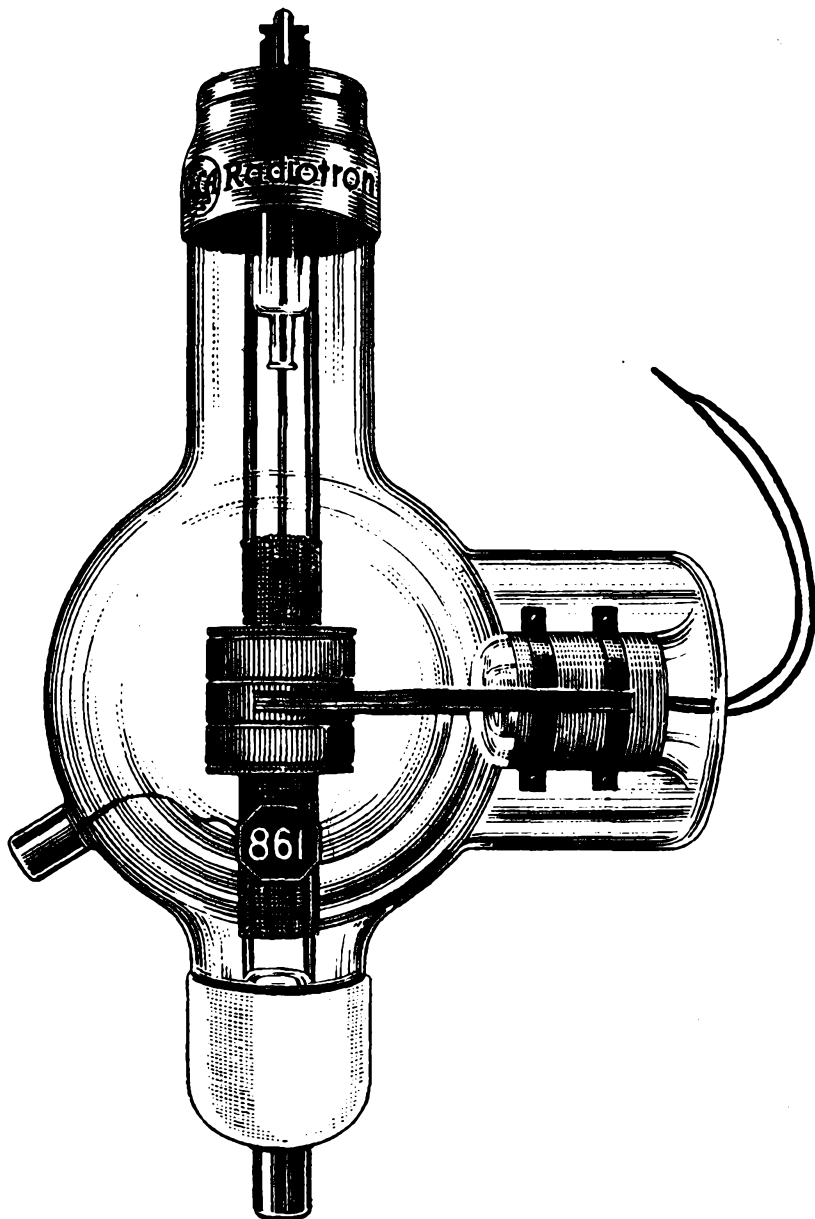

RCA-861

A high-power, heavy-duty tetrode  
— 400 watts plate dissipation—partic-  
ularly useful where rapid change  
of operating frequency is desired.



# RCA-861

## Screen-Grid R-F Power Amplifier

Illustrated on page 119

RCA-861 is a screen-grid transmitting tube of the thoriated-tungsten filament type for use as a radio-frequency power amplifier. The grid, plate, and screen are supported on separate stems and their leads brought out of the bulb through separate seals. This construction insures good insulation and low interelectrode capacitances. Neutralization to prevent feedback is generally unnecessary when the tube is used in adequately shielded circuits. The 861 may be operated at maximum input at frequencies as high as 20 megacycles.

### CHARACTERISTICS

Filament Volts (a-c or d-c) .....	11.0	Grid-Plate Capacitance (With external shielding) .....	0.1 max. $\mu\text{f}$
Filament Amperes .....	10	Input Capacitance .....	14.5 $\mu\text{f}$
Amplification Factor (Approx.) .....	300	Output Capacitance .....	10.5 $\mu\text{f}$
Transconductance (For plate current of 130 ma.) Micromhos.....	2100		

### MAXIMUM RATINGS AND TYPICAL OPERATING CONDITIONS

#### As R-F Power Amplifier—Class B Telephony

Carrier conditions per tube for use with a max. modulation factor of 1.0

D-C PLATE VOLTAGE .....	3500 max. Volts
D-C SCREEN VOLTAGE .....	750 max. Volts
D-C PLATE CURRENT .....	250 max. Milliampères
PLATE INPUT .....	600 max. Watts
SCREEN INPUT .....	35 max. Watts
PLATE DISSIPATION .....	400 max. Watts

#### TYPICAL OPERATION:

D-C Plate Voltage .....	2500	3000	3500	Volts
D-C Screen Voltage .....	500	500	500	Volts
D-C Grid Voltage <sup>§</sup> .....	-60	-60	-60	Volts
Peak R-F Grid Voltage .....	250	245	215	Volts
D-C Plate Current .....	190	175	150	Milliampères
D-C Grid Current (Approx.) .....	4	4	4	Milliampères
Screen Resistor .....	Not recommended			
Driving Power (Approx.) <sup>†</sup> .....	20	15	15	Watts
Power Output (Approx.) .....	140	160	175	Watts

#### As Plate-Modulated R-F Power Amplifier—Class C Telephony

Carrier conditions per tube for use with a max. modulation factor of 1.0

D-C PLATE VOLTAGE .....	3000 max. Volts
D-C SCREEN VOLTAGE .....	750 max. Volts
D-C GRID VOLTAGE .....	-1000 max. Volts
D-C PLATE CURRENT .....	300 max. Milliampères
D-C GRID CURRENT .....	75 max. Milliampères
PLATE INPUT .....	650 max. Watts
SCREEN INPUT .....	30 max. Watts
PLATE DISSIPATION .....	270 max. Watts

#### TYPICAL OPERATION:

D-C Plate Voltage .....	2000	2500	3000	Volts
D-C Screen Voltage .....	425	400	375	Volts
D-C Grid Voltage <sup>§</sup> .....	-250	-225	-200	Volts
Peak R-F Grid Voltage .....	675	625	575	Volts
D-C Plate Current .....	250	220	200	Milliampères
D-C Grid Current (Approx.) .....	65	60	55	Milliampères
Screen Resistor .....	30000	50000	70000	Ohms
Grid Resistor .....	3850	3750	3640	Ohms
Driving Power (Approx.) .....	45	40	35	Watts
Power Output (Approx.) .....	285	340	400	Watts

#### As R-F Power Amplifier and Oscillator—Class C Telegraphy

Key-down conditions per tube without modulation<sup>††</sup>

D-C PLATE VOLTAGE .....	3500 max. Volts
D-C SCREEN VOLTAGE .....	750 max. Volts

§, †: see next page.

D-C GRID VOLTAGE .....	-1000	max.	Volts
D-C PLATE CURRENT .....	350	max.	Milliamperes
D-C GRID CURRENT .....	75	max.	Milliamperes
PLATE INPUT .....	1200	max.	Watts
SCREEN INPUT .....	35	max.	Watts
PLATE DISSIPATION .....	400	max.	Watts

**TYPICAL OPERATION:**

D-C Plate Voltage .....	2000	3000	3500	Volts
D-C Screen Voltage .....	500	500	500	Volts
D-C Grid Voltage <sup>§</sup> .....	-250	-250	-250	Volts
Peak R-F Grid Voltage .....	725	725	725	Volts
D-C Plate Current .....	300	300	300	Milliamperes
D-C Screen Current .....	60	50	40	Milliamperes
D-C Grid Current (Approx.) .....	40	40	40	Milliamperes
Screen Resistor .....	Not recommended			
Grid Resistor .....	6250	6250	6250	Ohms
Driving Power (Approx.) .....	30	30	30	Watts
Power Output (Approx.) .....	400	600	700	Watts

§ Grid voltages are given with respect to the mid-point of filament operated on a.c. If d.c. is used, each stated value of grid voltage should be decreased by 8 volts and the circuit returns made to the negative end of the filament.

† At crest of audio-frequency cycle with modulation factor of 1.0.

†† Modulation essentially negative may be used if the positive peak of the audio-frequency envelope does not exceed 115% of the carrier conditions.

## INSTALLATION AND APPLICATION

The filament base and plate cap of the 861 fit the standard RCA end-mountings UT 1085 and UT-1086, respectively. The end-mountings should be placed to hold the tube in a vertical position with the small cap (plate) down. The screen has two connections which are brought out of the tube to the blade on the filament base and to the cap at the side of the bulb. Only one of these, preferably the blade, need be used for the screen-voltage supply. However, it is essential that both screen terminals be by-passed to ground through separate condensers to maintain low impedance between screen and filament.

The plate of the 861 shows an orange-red color at the maximum plate-dissipation rating for each class of service. The screen should never be allowed to show more than a barely perceptible red color.

For high-frequency operation above 20 megacycles, see page 144.

For additional information, see chapters on INSTALLATION and APPLICATION.

A plate family of curves is shown at the bottom of page 118.

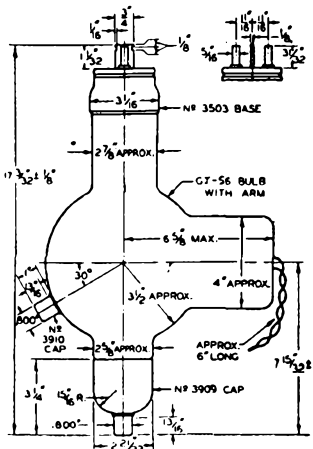

### Connections to End-Mountings

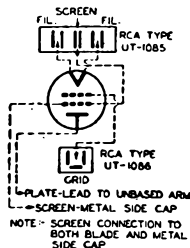

# RCA-864

## Amplifier

(Low Microphonic Design)

RCA-864 is a high-vacuum, three-electrode tube of the general-purpose type. The tube is designed with a coated filament and is intended for use under conditions where freedom from microphonic disturbance is required. It is applicable as a detector, amplifier, or oscillator in battery-operated equipment which may be subject to either impact or continuous vibration.

### CHARACTERISTICS

Filament Volts (d-c) .....	1.1	Grid-Plate Capacitance .....	5.3 $\mu\text{f}$
Filament Amperes .....	0.25	Grid-Filament Capacitance .....	3.3 $\mu\text{f}$
		Plate-Filament Capacitance .....	2.1 $\mu\text{f}$

### As A-F Amplifier—Class A

D-C PLATE VOLTAGE .....	90	135 max.	Volts
D-C GRID VOLTAGE .....	-4.5	-9	Volts
D-C PLATE CURRENT .....	2.9	3.5	Milliamperes
PLATE RESISTANCE .....	13500	12700	Ohms
AMPLIFICATION FACTOR .....	8.2	8.2	
TRANSCONDUCTANCE .....	610	645	Micromhos

### INSTALLATION AND APPLICATION

The base pins of the 864 fit the standard 4-contact socket which may be mounted to hold the tube in any position. Except in high-gain circuits, cushioning of the socket will generally be unnecessary.

The coated filament is designed for d-c operation. The filament supply may be from dry-cells or from a single lead storage cell. The filaments of 864's should preferably be operated in parallel although it is permissible to operate several tubes in series provided the rated filament current of 0.25 ampere is maintained.

As an amplifier in transformer-coupled circuits, the 864 should be operated as shown under CHARACTERISTICS. As an amplifier in resistance-coupled circuits, considerable leeway of plate-supply voltage is permissible provided the plate-coupling resistor and grid bias are chosen so as to limit the average voltage at the plate to the maximum value of 135 volts. The average voltage is that existing when no signal is impressed. A grid resistor of not more than 2 megohms is recommended.

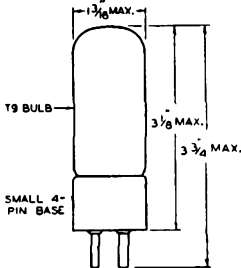

Top view of Socket Connections

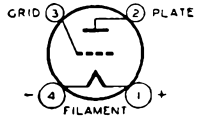

AVERAGE PLATE CHARACTERISTICS

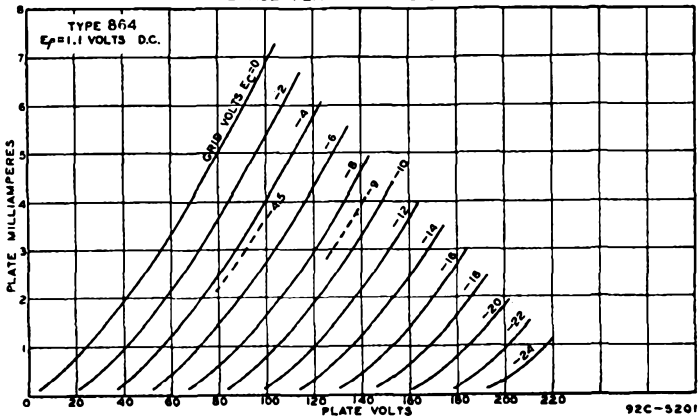

# RCA-865

## Screen-Grid R-F Power Amplifier

Illustrated on page 133

RCA-865 is a screen-grid transmitting tube of the thoriated-tungsten filament type for use as an r-f amplifier and frequency multiplier. The plate connection is brought out through a separate seal at the top of the bulb to maintain low grid-plate capacitance. Neutralization to prevent feedback is generally unnecessary when this tube is used in adequately shielded circuits. The 865 can be operated at maximum ratings in all classes of service at frequencies as high as 15 megacycles.

### CHARACTERISTICS

Filament Volts (a-c or d-c) .....	7.5	Grid-Plate Capacitance (with external shielding) .....	0.10 max. $\mu\text{f}$
Filament Amperes .....	2	Input Capacitance .....	8.5 $\mu\text{f}$
Amplification Factor (Approx.) .....	150	Output Capacitance .....	8 $\mu\text{f}$
Transconductance (For plate current of 18 ma.) Micromhos .....	750		

### MAXIMUM RATINGS

	Class B Tele- phony*	Class C Tele- phony*	Class C Tele- graphy‡	
D-C PLATE VOLTAGE .....	750	500	750	Volts
D-C SCREEN VOLTAGE .....	175	175	175	Volts
D-C GRID VOLTAGE .....	—	-250	-250	Volts
D-C PLATE CURRENT .....	30	60	60	Milliamperes
D-C GRID CURRENT .....	—	15	15	Milliamperes
PLATE INPUT .....	22.5	30	45	Watts
SCREEN INPUT .....	3	2	3	Watts
PLATE DISSIPATION .....	15	10	15	Watts

\* Carrier conditions per tube for use with a max. modulation factor of 1.0.

‡ Key-down conditions per tube without modulation. Modulation essentially negative may be used if the positive peak of the audio-frequency envelope does not exceed 115% of the carrier conditions.

### INSTALLATION AND APPLICATION

The base pins of the 865 fit the standard 4-contact socket, such as the RCA type UR-542A. The socket should be installed to hold the tube in a vertical position with the base down.

The plate of the 865 shows no color at the maximum plate-dissipation ratings for each class of service. The screen should not be allowed to show more than a barely perceptible red color.

For high-frequency operation above 15 megacycles, see page 144.

When the screen voltage is obtained from a series screen resistor, the value of the resistor should be not less than 20,000 ohms for a plate-supply voltage of 500 volts, 32,000 ohms for 625 volts, and 45,000 ohms for 750 volts.

For additional information, see chapters on INSTALLATION and APPLICATION.

Top View of  
Socket Connections

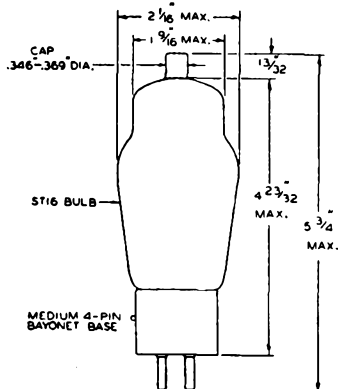
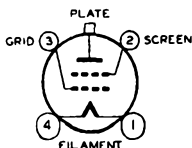

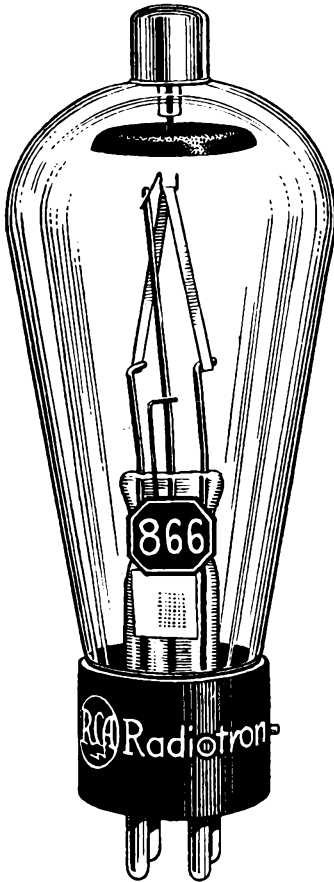

**RCA-866**

The standard, half-wave, mercury-vapor rectifier type used in nearly every transmitter—a rugged, reliable, economical tube of proven performance.

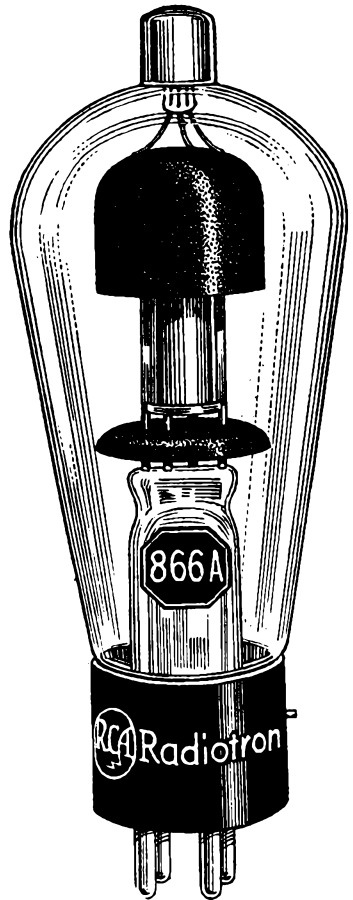

**RCA-866-A**

A rectifier for applications requiring higher voltages than the maximum ratings of the 866 permit.

# RCA-866 and RCA-866-A

## Half-Wave, Mercury-Vapor Rectifiers

RCA-866 and RCA-866-A are half-wave, mercury-vapor rectifier tubes of the coated filament type. They are for use primarily in high-voltage rectifying devices designed to supply d-c power of uniform voltage.

### CHARACTERISTICS

	RCA-866	RCA-866-A	
FILAMENT VOLTAGE (a-c) .....	2.5	2.5	Volts
FILAMENT CURRENT .....	5	5	Amperes
<b>PEAK INVERSE VOLTAGE:</b>			
Cond. Mercury Temp. of 10° to 60°C* ...	7500 max.	—	Volts
Cond. Mercury Temp. of 25° to 60°C* ...	—	10000 max.	Volts
Cond. Mercury Temp. of 25° to 70°C**	—	5000 max.	Volts
PEAK PLATE CURRENT .....	1.0 max.	1.0 max.	Ampere
AVERAGE PLATE CURRENT .....	0.25 max.	0.25 max.	Ampere
TUBE VOLTAGE DROP (Approx.) .....	15	10	Volts

\* For supply frequency up to 150 cycles. \*\* For supply frequency up to 1000 cycles.

### INSTALLATION AND APPLICATION

The base pins of the 866 and 866-A fit the standard 4-contact socket, such as the RCA type UR-542A. The socket should be installed to hold the tubes in a vertical position, base down. The plate lead of each tube is brought out through a separate seal at the top of the bulb.

During initial operation, the 866 should be operated for 15 minutes with normal filament voltage and no plate voltage; the 866-A, for 30 minutes with normal filament voltage and no plate voltage. This is done to distribute the mercury properly. The procedure need not be repeated unless, during subsequent handling, the mercury is spattered on the filament and plate.

The filament of the 866 and 866-A should be allowed to come up to operating temperature before the plate voltage is applied. For average conditions the delay should be approximately 30 seconds.

The 866 is capable of delivering a maximum peak plate current of 2.0 amperes provided the peak plate voltage does not exceed 200 volts and the supply frequency does not exceed 150 cycles. Likewise, the 866-A is capable of delivering a maximum peak plate current of 2.0 amperes provided the peak plate voltage does not exceed 200 volts and the supply frequency does not exceed 1,000 cycles.

For additional information, see chapter on RECTIFIERS and FILTERS.

Top View of Socket Connections

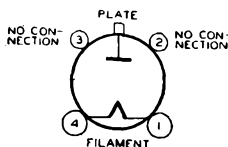

RCA-866 and 866-A

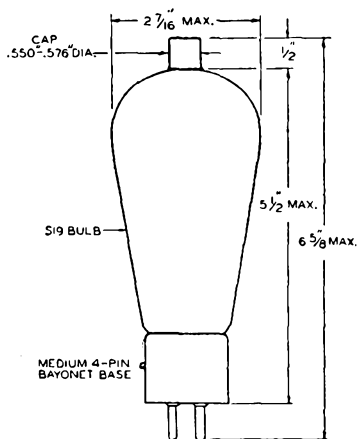

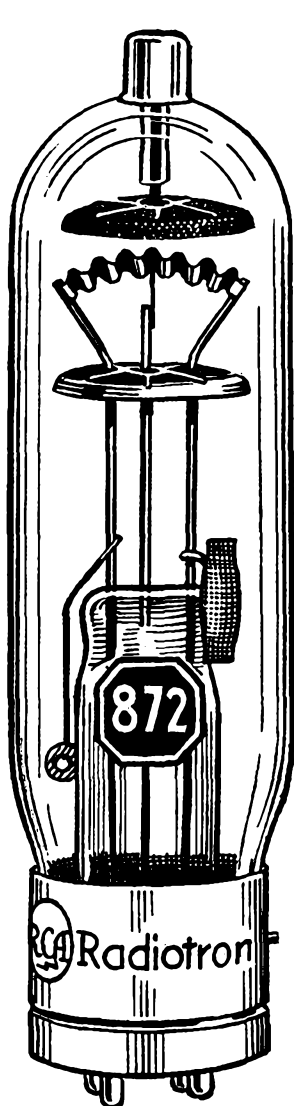

RCA-872

A mercury-vapor rectifier—for the plate supply of the high-power stages—has maximum ratings of 7500 peak inverse volts, 5 peak plate amperes.

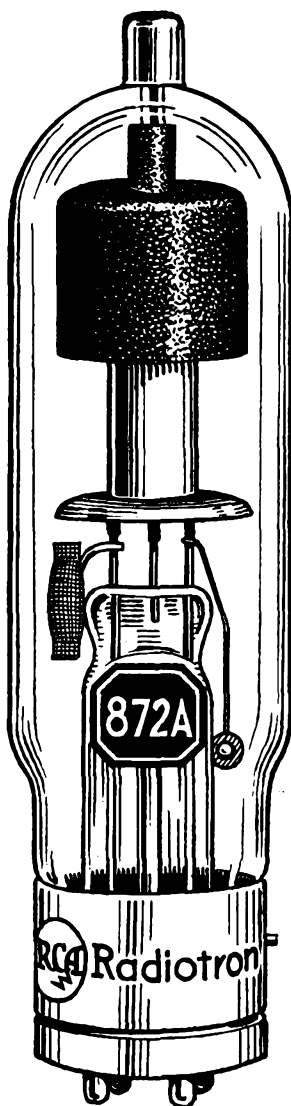

RCA-872-A

Similar to the 872 but has a peak-inverse-voltage rating of 10,000 volts.

# RCA-872 and RCA-872-A

## Half-Wave, Mercury-Vapor Rectifiers

RCA-872 and RCA-872-A are half-wave, mercury-vapor rectifier tubes of the coated filament type. They are intended for use in high-voltage devices designed to supply d-c power of uniform voltage.

### CHARACTERISTICS

	RCA-872	RCA-872-A	
FILAMENT VOLTAGE (a-c) .....	5.0	5.0	Volts
FILAMENT CURRENT .....	10	6.75*	Amperes
<b>PEAK INVERSE VOLTAGE**:</b>			
Cond. Mercury Temp. of 10° to 60°C.....	7500 max.	—	Volts
Cond. Mercury Temp. of 20° to 60°C.....	—	10000 max.	Volts
Cond. Mercury Temp. of 20° to 70°C.....	—	5000 max.	Volts
PEAK PLATE CURRENT .....	5 max.	5 max.	Amperes
AVERAGE PLATE CURRENT§ .....	1.25 max.	1.25 max.	Amperes
TUBE VOLTAGE DROP (Approx.) .....	15	10	Volts

\* Filament transformer should be designed for 10 amperes per tube.

\*\* For supply frequency up to 150 cycles.

§ Averaged over a period of 15 seconds.

### INSTALLATION AND APPLICATION

The base pins of the 872 and 872-A fit the standard transmitting 4-contact socket, such as the RCA type UT-541A. The socket should be installed to hold the tubes in a vertical position, base down. The plate lead of each tube is brought out through a separate seal at the top of the bulb.

For outline drawing, refer to Type 805.

During initial operation, the 872 and 872-A should be operated for 15 minutes with normal filament voltage and no plate voltage in order to distribute the mercury properly. This procedure need not be repeated unless, during subsequent handling, the mercury is spattered on the filament and plate.

The filament of the 872 or 872-A should be allowed to come up to operating temperature before the plate voltage is applied. For average conditions the delay should be approximately 30 seconds.

For additional information, see chapter on RECTIFIERS and FILTERS.

Top View of Socket Connections

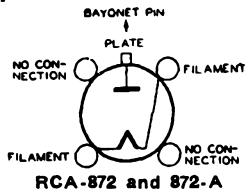



# RCA-954

## Detector, Amplifier Pentode (Acorn† Type)

For illustration, refer to 956 on page 133

The 954 is a heater-cathode type of pentode designed primarily for radio amateurs and experimenters working with wavelengths as short as 0.7 meter. As an r-f amplifier at a wavelength of one meter, the 954 is capable of gains of three or more in circuits of conventional design. Higher gains are, of course, attainable at longer wavelengths. Operation at short wavelengths is made possible by means of unconventional tube structure having small size, close electrode spacing, and short terminal connections.

### CHARACTERISTICS

Heater Volts (a-c or d-c) .....	6.3	Grid-Plate Capacitance	
Heater Amperes .....	0.15	(With shield baffle) .....	0.007 max. $\mu\mu\text{f}$
		Input Capacitance .....	3 $\mu\mu\text{f}$
		Output Capacitance .....	3 $\mu\mu\text{f}$

### As an R-F or A-F Amplifier—Class A

D-C PLATE VOLTAGE .....	250 max.	Volts
D-C SUPPRESSOR VOLTAGE (Grid No. 3).....	100 max.	Volts
D-C SCREEN VOLTAGE (Grid No. 2).....	100 max.	Volts

#### TYPICAL OPERATION AND CHARACTERISTICS:

D-C Plate Voltage .....	90	250	Volts
Suppressor .....	Connected to cathode at socket		
D-C Screen Voltage .....	90	100	Volts
D-C Grid Voltage (Grid No. 1) .....	-3	-3	Volts
D-C Plate Current .....	1.2	2	Milliamperes
D-C Screen Current .....	0.5	0.7	Milliampere
Amplification Factor .....	1100	Greater than 2000	
Plate Resistance .....	1.0	Greater than 1.5 Megohms	
Transconductance .....	1100	1400	Micromhos

### As Detector

D-C PLATE VOLTAGE .....	250 max.	Volts
D-C SUPPRESSOR VOLTAGE .....	100 max.	Volts
D-C SCREEN VOLTAGE .....	100 max.	Volts

#### TYPICAL OPERATION AS BIASED DETECTOR:

D-C Plate-Supply Voltage .....	250	Volts
Suppressor .....	Connected to cathode at socket	
D-C Screen Voltage .....	100	Volts
D-C Grid Voltage (Approx.) .....	-6	Volts
D-C Plate Current .....	Adjusted to 0.1 ma. with no input signal	
Plate Load* .....	250000 Ohms, or Equivalent Impedance	
Cathode-Bias Resistor .....	20000 to 50000 Ohms	

\* For resistance load, voltage at the plate will be less than the plate-supply voltage by an amount equal to the voltage drop in the load resistor caused by the plate current.

### INSTALLATION

The terminals of the 954 require a special method of mounting by means of clips supplied with each tube. The two small clips are for the control grid and the plate terminal at the bottom and top of the bulb, respectively. The five

† Registered Trademark.

large clips may be fastened to a supporting insulator. For minimum losses, it is desirable to clip circuit parts directly to the control-grid terminal and to the plate terminal. Since the circumferential tube terminals are located symmetrically, a stop of insulating material should be placed between the screen clip and the suppressor clip so that the cathode terminal will prevent insertion of the heater terminals in the screen and suppressor clips. This stop is identified on the Terminal Mounting Template shown under type 956 as Alignment Plug. *Do not attempt to solder connections to the terminals.* The heat of the soldering operation is almost certain to crack the bulb seal.

The heater is designed to operate on either a.c. or d.c. When a.c. is used the winding which supplies the heater circuit should operate the heater at its recommended value for full-load operating conditions at average line voltage. When d.c. is used on the heater, the heater terminals should be connected directly across a 6-volt battery. Under any condition of operation, the heater voltage should not deviate more than plus or minus 10% from the normal value of 6.3 volts. Series heater operation of the 954 is not recommended.

The cathode of the 954, when operated from a transformer, should preferably be connected directly to the electrical mid-point of the heater circuit. In the case of d-c operation from a 6-volt storage battery, the cathode circuit is tied in either directly or through bias resistors to the negative battery terminal. In circuits where the cathode is not directly connected to the heater, the potential difference between heater and cathode should be kept as low as possible. If the use of a large resistor is necessary between heater and cathode in some circuit designs, it is essential that this resistor be by-passed by a suitable filter network or objectional hum may develop.

The screen voltage may be obtained from a fixed tap on the B-battery or from a potentiometer across the B-supply. The screen voltage may be obtained from the B-supply through a series resistor when the tube is self-biased by means of a cathode resistor. The latter method is not recommended if the B-supply exceeds 250 volts.

**Shielding** of each r-f amplifier stage employing the 954 is required in order to prevent interstage coupling. A convenient method of shield construction is illustrated under type 956. The control-grid end of the tube is inserted through a hole in a metal plate so that the metal edge of the hole is in close proximity to the internal shield in the control-grid end of the tube. It may be desirable, depending upon circuit requirements, to provide a small collar on the baffle hole in order to increase the shielding effect.

**R-f grounding** by means of condensers placed close to the tube terminals is required if the full capabilities of the 954 are to be realized at the ultra-high frequencies. Conventional by-passing methods and grounding are not adequate. One convenient method is to use ribbon lead-ins to the clips and to insulate the ribbon lead-ins and the terminal clips from the grounding plate by mica spacers to form by-pass condensers right at the tube terminals. It is important in the cases of the plate and control-grid circuits that separate r-f grounding returns be made to a common point in order to avoid r-f interaction through common return circuits. It may also be advisable in some applications to supplement the action of the by-pass condensers by r-f chokes placed close to the condensers in the return or supply lead for the control grid, the screen, the suppressor, the plate, and the heater.

## APPLICATION

As an amplifier, the 954 is applicable to the audio- or the radio-frequency stages of short-wave receivers, especially those operating at wavelengths as short as 0.7 meter. Typical operating conditions for this service are given under **MAXIMUM RATINGS** and **TYPICAL OPERATING CONDITIONS**.

For a-f amplifier circuits, typical operating conditions are as follows: Plate-supply voltage, 250 volts; screen voltage, 50 volts; grid voltage, -2.1 volts; suppressor, connected to cathode at socket; plate-load resistor, 250000 ohms; and plate current, 0.5 milliampere. The grid resistor may be made as high as 1.0 megohm. Under these conditions, an undistorted voltage output of 40 to 50 volts RMS may be obtained. The voltage amplification is approximately 100.

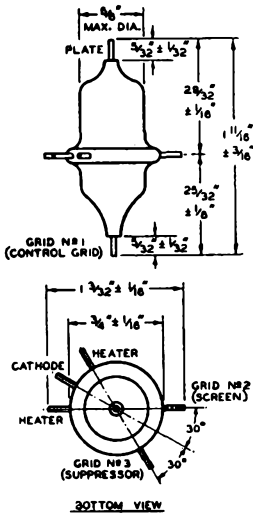
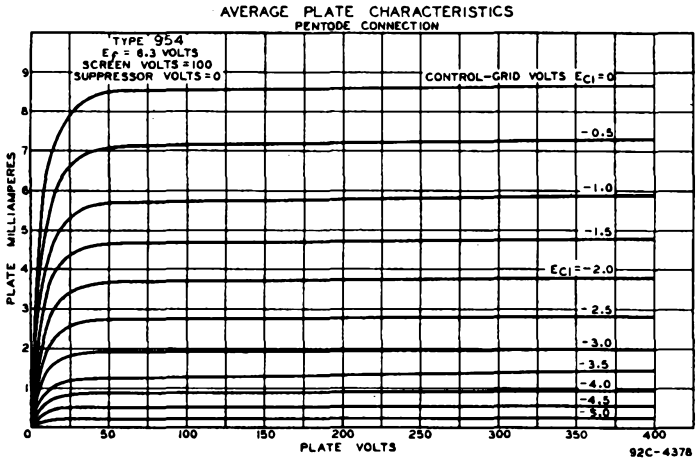

TYPICAL R-F AMPLIFIER CIRCUIT

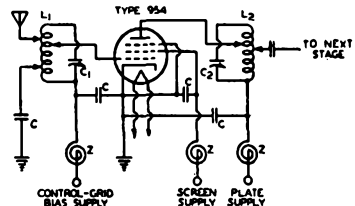

	2.75 TO 3.3 METERS APPROX.	1 TO 3 METERS APPROX.	0.8 METER APPROX.
L <sub>1</sub> -L <sub>2</sub> (OUTSIDE DIA. LENGTH)	10 N830 B.C. <sup>#</sup> 3/8 3/8	4 N830 B.C. <sup>#</sup> 3/8 3/8	N830 B.C. <sup>#</sup> 1/8 1/8
C <sub>1</sub> , C <sub>2</sub> (VARIABLE)	3 TO 25 μF	3 TO 25 μF	3 TO 4 μF
C	100 TO 500 μF	100 TO 500 μF	100 TO 500 μF
Z (TURNS WIRE OUTSIDE DIA. WINDING)	15 N830 1/2 S.L. <sup>®</sup>	15 N830 1/2 S.L. <sup>®</sup>	15 N830 1/4 S.L. <sup>®</sup>

<sup>#</sup>B.C. = BARE COPPER      <sup>®</sup>S.L. = SINGLE LAYER  
NOTE: THE ABOVE DATA ARE NECESSARILY APPROXIMATE FOR ULTRA-HIGH FREQUENCIES. COILS L<sub>1</sub> AND L<sub>2</sub> MAY BE TAPPED AT SUITABLE POINTS DETERMINED BY TEST TO REDUCE EFFECT OF TUBE LOADING ON CIRCUIT IMPEDANCES. SINCE ELECTRONIC PLATE LOADING IS NOT SERIOUS IN A PENTODE, THE USE OF COIL L<sub>2</sub> WITH TAPPED PLATE CONNECTION MAY NOT BE NECESSARY TO GIVE SATISFACTORY RESULTS. THE CONDENSERS SHOULD ALL BE OF HIGH QUALITY AND BE DESIGNED FOR ULTRA-HIGH FREQUENCY OPERATION.

# RCA-955

## Detector, Amplifier, Oscillator

(Acorn Type)

*Illustrated on page 133*

The 955 is a heater-cathode type of triode designed primarily for radio amateurs and experimenters working with wavelengths between 0.5 meter and 5 meters. Operation at these short wavelengths is made possible by means of an unconventional tube structure having small size, close electrode spacing, and short terminal connections.

### CHARACTERISTICS

Heater Volts (a-c or d-c) .....	6.3	Grid-Plate Capacitance .....	1.4 $\mu\mu\text{f}$
Heater Amperes .....	0.15	Grid-Cathode Capacitance .....	1 $\mu\mu\text{f}$
Amplification Factor .....	25	Plate-Cathode Capacitance .....	0.6 $\mu\mu\text{f}$

### MAXIMUM RATINGS AND TYPICAL OPERATING CONDITIONS

#### As R-F or A-F Amplifier—Class A

D-C PLATE VOLTAGE .....				180 max. Volts
<b>TYPICAL OPERATION AND CHARACTERISTICS:</b>				
D-C Plate Voltage .....	90	135	180	Volts
D-C Grid Voltage* .....	-2.5	-3.75	-5	Volts
D-C Plate Current .....	2.5	3.5	4.5	Milliamperes
Plate Resistance .....	14700	13200	12500	Ohms
Transconductance .....	1700	1900	2000	Micromhos
Load Resistance .....	-	-	20000	Ohms
Undistorted Power Output .....	-	-	135	Milliwatts

#### As R-F Power Amplifier and Oscillator—Class C Telegraphy or Plate-Modulated Telephony

D-C PLATE VOLTAGE .....				180 max. Volts
D-C PLATE CURRENT .....				8 max. Milliamperes
D-C GRID CURRENT .....				2 max. Milliamperes
<b>TYPICAL OPERATION:</b>				
D-C Plate Voltage .....				180 Volts
D-C Grid Voltage .....				-35 Volts
D-C Plate Current .....				7 Milliamperes
Grid Resistor (Approx.) .....				23000 Ohms
D-C Grid Current (Approx.) .....				1.5 Milliamperes
Power Output (Approx.)** .....				0.5 Watt

\* The d-c resistance in the grid circuit should not exceed 0.5 megohm.

\*\* At 5 meters. Only moderate reduction in this value will be found for wavelengths as low as 1 meter. Below 1 meter, the power output decreases as the wavelength is decreased.

### INSTALLATION AND APPLICATION

For terminal mounting considerations, refer to type 954. For Terminal Mounting Template, refer to type 956.

For heater, cathode, and r-f grounding considerations, refer to type 954.

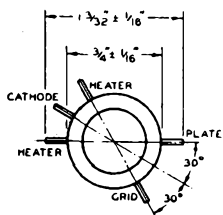
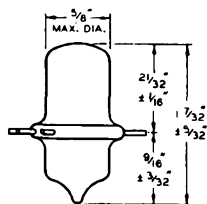

BOTTOM VIEW

As a detector, the 955 may be of the grid-leak-and-condenser type or of the grid-bias type. The plate voltage for the grid-leak-and-condenser method should be about 45 volts. A grid leak of from 1 to 5 megohms with a condenser of 0.00025  $\mu$ f is satisfactory. For the grid-bias method of detection, a plate-supply voltage of 180 volts may be used together with a negative grid-bias voltage of approximately -7 volts. The plate current should be adjusted to a little less than 0.2 milli-ampere with no input signal voltage. The grid-bias voltage may be supplied from the voltage drop in a resistor between cathode and ground. The value of this self-biasing resistor is not critical, 50000 ohms being suitable.

In miscellaneous applications in the laboratory, such as vacuum-tube voltmeters, the 955 can, because of its small size, be placed at the point of measurement. This feature combined with that of low input capacitance, makes possible vacuum-tube voltmeter measurements with a minimum effect on the constants of the circuit under measurement.

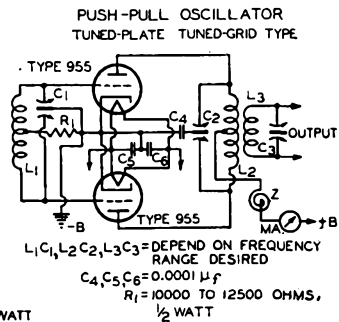
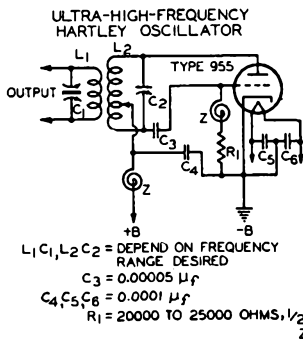
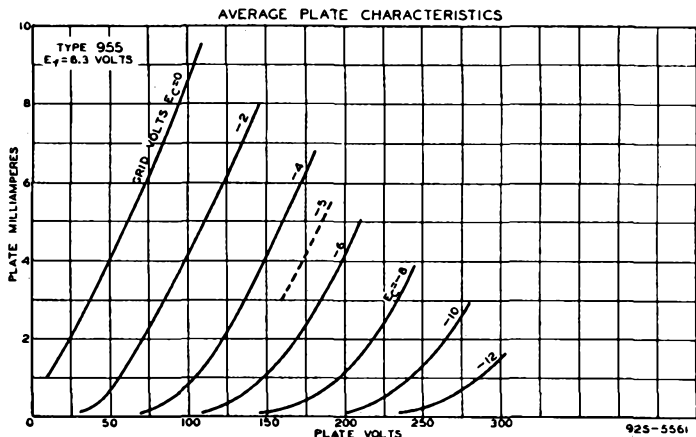

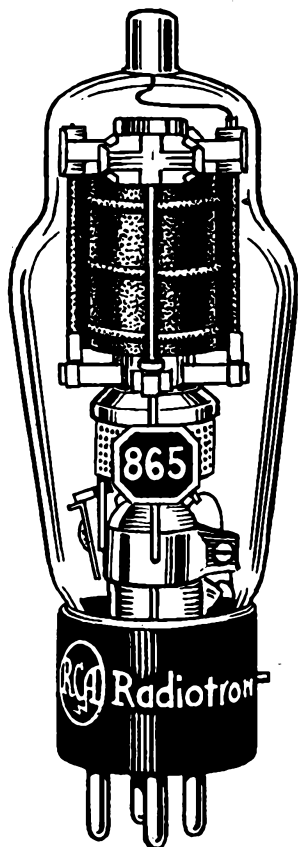

**RCA-865**

Tetrode — for buffer or doubler stages—requires no neutralization—easy to drive—gives good power gain.

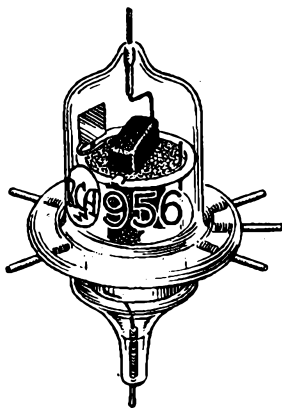

**RCA-956**

Acorn type pentode — companion tube to 954 and 955—indispensable to the designer of ultra-high-frequency equipment.

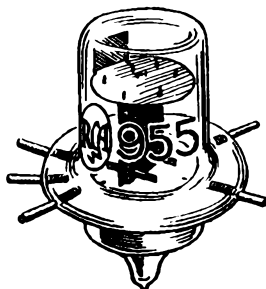

**RCA-955**

Acorn type triode—for the ultra-high-frequency receiver or "fly-power" transmitter—operates at frequencies unreachable with conventional tubes.

# RCA-956

## Super-Control R-F Amplifier Pentode (Acorn Type)

*Illustrated on page 133*

RCA-956 is a heater-cathode tube of the remote cut-off type for use by radio amateurs and experimenters as a radio- and intermediate-frequency amplifier, or mixer, in receivers operating at wavelengths as low as 0.7 meter. The super-control feature of the 956 makes the tube very effective in reducing cross-modulation and modulation-distortion over the entire range of received signals. This feature also makes the tube well-adapted to circuits incorporating automatic volume control, without the necessity for using local-distance switches or antenna potentiometers. At a wavelength of one meter, the 956 is capable of giving a gain of four or more when it is used as an r-f amplifier in circuits of conventional design. Higher gains are, of course, attainable at longer wavelengths. Operation at short wavelengths is made possible by means of an unconventional tube structure having small size, close electrode spacing, and short terminal connections.

### CHARACTERISTICS

Heater Volts (a-c or d-c) .....	6.3	Grid-Plate Capacitance	
Heater Amperes .....	0.15	(With shield baffle) .....	0.007 max. $\mu\text{f}$
Amplification Factor .....	1440	Input Capacitance .....	2.7 $\mu\text{f}$
		Output Capacitance .....	3.5 $\mu\text{f}$

### As R-F Amplifier—Class A

D-C PLATE VOLTAGE .....	250 max.	Volts	
SUPPRESSOR (Grid No. 3)* .....	Connected to	cathode at mounting	
D-C SCREEN VOLTAGE (Grid No. 2).....	100 max.	Volts	
D-C GRID VOLTAGE (Grid No. 1).....	-3 min.	Volts	
D-C PLATE CURRENT .....	5.5	Milliamperes	
D-C SCREEN CURRENT .....	1.8	Milliamperes	
PLATE RESISTANCE .....	0.8	Megohm	
TRANSCONDUCTANCE .....	1800	Micromhos	
TRANSCONDUCTANCE (At -45 volts bias) .....	2	Micromhos	

\* Maximum d-c voltage=100 volts.

### INSTALLATION AND APPLICATION

For terminal mounting considerations and outline drawing, refer to type 954.

For heater and cathode considerations, refer to type 954.

The screen voltage may be obtained from a potentiometer or bleeder circuit across the B-supply source. Due to the screen current characteristics of the 956, a resistor in series with the high-voltage supply may be employed for obtaining the screen voltage provided the cathode-resistor method of bias control is used. This method, however, is not recommended if the high-voltage B-supply exceeds 250 volts. Furthermore, it should be noted that the use of a resistor in the screen circuit will have an effect on the change in plate resistance with variation in suppressor voltage in case the suppressor is utilized for control purposes.

Shielding and r-f grounding requirements are the same as for the 954. A convenient method of shield construction is shown on the next page.

As a radio-frequency and intermediate-frequency amplifier, the 956 should be operated as shown under CHARACTERISTICS.

Volume control of receivers using this tube may be accomplished by variation of the negative grid bias. In order to realize the full volume-control range of the 956, an available grid-bias voltage of approximately 50 volts will be required, depending on the circuit design and operating conditions. This voltage may be obtained from a potentiometer, a bleeder, or from an adjustable cathode resistor.

As a mixer in superheterodyne receivers, the 956 may be used under the following conditions: Plate voltage, 250 volts; screen voltage, 100 volts; and grid bias, -10 volts approximately (with a 7-volt peak swing from the oscillator). The suppressor should be connected to the cathode at the mounting.

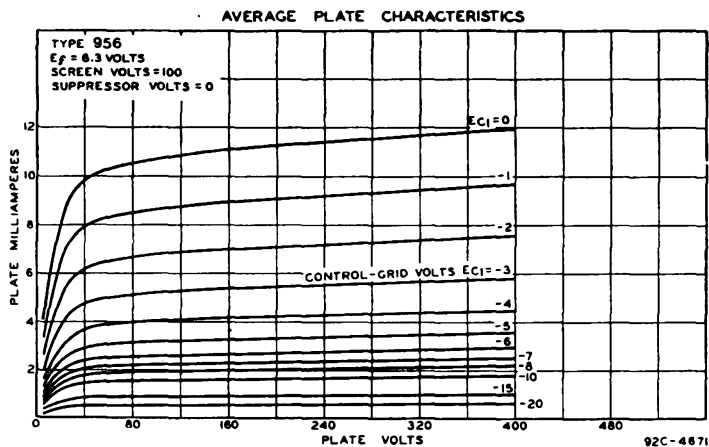

TERMINAL MOUNTING TEMPLATE  
 TOP VIEW

Typical Shield Construction

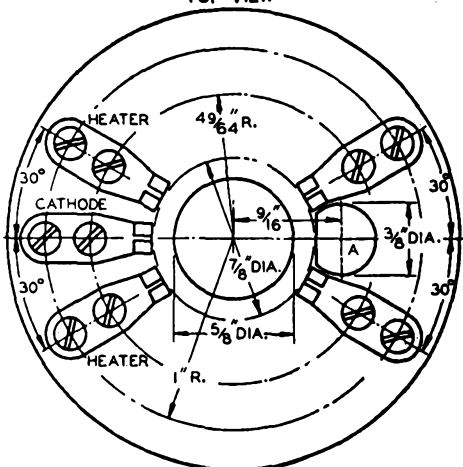
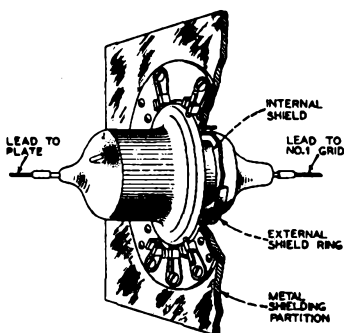

A = ALIGNMENT PLUG  $\frac{1}{4}$ " HIGH

NOTE: INSERT TUBE IN CLIPS SO THAT SHORT TIPPED END OF THE BULB RESTS IN THE MOUNTING HOLE



# RCA-1602

## Amplifier Triode

(For applications critical as to microphonics)

RCA-1602 is a three-electrode tube intended for use as an audio-frequency amplifier in applications critical as to microphonics.

This tube was formerly designated as the RCA-10-Special.

### CHARACTERISTICS

Filament Volts (a-c or d-c) .....	7.5	Grid-Plate Capacitance .....	7 $\mu\text{f}$
Filament Amperes .....	1.25	Grid-Filament Capacitance .....	4 $\mu\text{f}$
Amplification Factor .....	8	Plate-Filament Capacitance .....	3 $\mu\text{f}$

### MAXIMUM RATINGS

As A-F Power Amplifier

	Class A*	Class B	
D-C PLATE VOLTAGE .....	425	425	Volts
MAX.-SIGNAL D-C PLATE CURRENT** .....	—	60	Milliamperes
MAX.-SIGNAL PLATE INPUT** .....	—	25	Watts
PLATE DISSIPATION .....	12	12**	Watts

As R-F Power Amplifier

	Class B Tele- phony†	Class C Tele- phony†	Class C Tele- graphy‡	
D-C PLATE VOLTAGE .....	450	350	450	Volts
D-C GRID VOLTAGE .....	—	-200	-200	Volts
D-C PLATE CURRENT .....	45	50	60	Milliamperes
D-C GRID CURRENT .....	—	15	15	Milliamperes
PLATE INPUT .....	18	17.5	27	Watts
PLATE DISSIPATION .....	15	10	15	Watts

\* Undistorted power output is 1.6 watts at a plate voltage of 425 volts, a grid bias of -40 volts, and a load resistance of 10200 ohms.

\*\* Averaged over any audio-frequency cycle of sine-wave form.

† Carrier conditions per tube for use with a max. modulation factor of 1.0.

‡ Key-down conditions per tube without modulation. Modulation essentially negative may be used if the positive peak of the audio-frequency envelope does not exceed 115% of the carrier conditions.

### INSTALLATION AND APPLICATION

The base pins of the 1602 fit the standard 4-contact socket, such as the UR-542A. For high-frequency operation above 6 megacycles, see page 144.

For additional operating information, refer to the type 801 and to the chapters on INSTALLATION and APPLICATION.

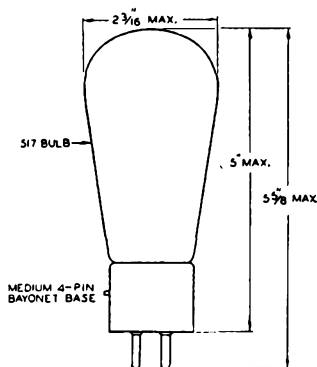

Top View of Socket Connections

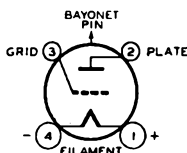

# RCA-1603

## Triple-Grid Detector Amplifier

(Low-microphonic, low-noise design)

RCA-1603 is a triple-grid tube of the heater-cathode type for use in pre-amplifier equipment critical as to noise and microphonics. The 1603 is constructed with an internal shield connected to the cathode within the tube.

### CHARACTERISTICS

Heater Volts ..... 6.3 Heater Amperes ..... 0.3

	Pentode Connection	Triode Connection <sup>†</sup>	
Grid-Plate Capacitance ...	0.007 max. (With shield can)	2	$\mu\text{f}$
Input Capacitance .....	5	3	$\mu\text{f}$
Output Capacitance .....	6.5	10.5	$\mu\text{f}$

### As Class A Amplifier Pentode

D-C PLATE VOLTAGE .....	100	250 max. Volts
SUPPRESSOR (Grid No. 3) .....	Connected to cathode at socket	
D-C SCREEN VOLTAGE (Grid No. 2).....	100	100 max. Volts
D-C GRID VOLTAGE (Grid No. 1)*.....	-3	-3 Volts
D-C PLATE CURRENT .....	2	2 Milliamperes
D-C SCREEN CURRENT .....	0.5	0.5 Milliampere
PLATE RESISTANCE .....	1	Greater than 1.5 Megohms
AMPLIFICATION FACTOR .....	1185	Greater than 1500
TRANSCONDUCTANCE .....	1185	1225 Micromhos

### As Class A Amplifier Triode<sup>†</sup>

D-C PLATE VOLTAGE .....	180	250 max. Volts
D-C GRID VOLTAGE .....	-5.3	-8 Volts
D-C PLATE CURRENT .....	5.3	6.5 Milliamperes
PLATE RESISTANCE .....	11000	10500 Ohms
AMPLIFICATION FACTOR (Approx.) .....	20	20
TRANSCONDUCTANCE .....	1800	1900 Micromhos

\* D-c grid voltage is -7 volts for cathode current cut-off.

† Grids No. 2 and No. 3 connected to plate.

Top View of Socket Connections

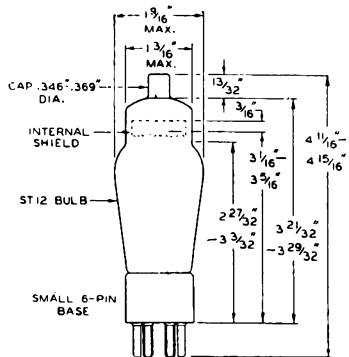
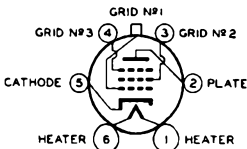

# RCA-1608

## R-F Power Amplifier, Oscillator, Class B Modulator

RCA-1608 is a three-electrode transmitting tube of the coated filament type for use as an r-f power amplifier, oscillator and class B modulator. It is capable of giving relatively high power output at low plate voltage. In r-f service, the 1608 may be operated at maximum ratings at frequencies as high as 45 megacycles. RCA-1608 has a ceramic base.

### TENTATIVE CHARACTERISTICS AND RATINGS

Filament Volts (a-c or d-c) .....	2.5	Grid-Plate Capacitance .....	9 $\mu\text{f}$
Filament Amperes .....	2.5	Grid-Filament Capacitance .....	8.5 $\mu\text{f}$
Amplification Factor .....	20	Plate-Filament Capacitance .....	3 $\mu\text{f}$

### MAXIMUM RATINGS

#### As A-F Power Amplifier and Modulator—Class B

D-C PLATE VOLTAGE .....	425 max. Volts
MAX.-SIGNAL D-C PLATE CURRENT* .....	95 max. Milliamperes
MAX.-SIGNAL PLATE INPUT* .....	40 max. Watts
PLATE DISSIPATION* .....	20 max. Watts

#### As R-F Power Amplifier

	Class B Tele- phony <sup>§</sup>	Class C Tele- phony <sup>§</sup>	Class C Tele- graphy <sup>‡</sup>	
D-C PLATE VOLTAGE .....	425	350	425	Volts
D-C GRID VOLTAGE .....	—	-200	-200	Volts
D-C PLATE CURRENT .....	70			Milliamperes
D-C GRID CURRENT .....		25	25	Milliamperes
PLATE INPUT .....	30	30	40	Watts
PLATE DISSIPATION .....	20	13.5	20	Watts

\* Averaged over any audio-frequency cycle of sine-wave form.

‡ Carrier conditions per tube for use with a max. modulation factor of 1.0.

‡ Key-down conditions per tube without modulation. Modulation essentially negative may be used if the positive peak of the audio-frequency envelope does not exceed 115% of the carrier conditions.

### INSTALLATION AND APPLICATION

The base pins of the RCA-1608 fit the standard 4-contact socket, such as the RCA type UR-542A. The socket may be mounted to hold the tube in any position.

The plate of the 1608 shows no color when the tube is operated at the maximum plate-dissipation rating for each service.

For high-frequency operation above 45 megacycles, see page 144.

For additional information, see chapters on INSTALLATION and APPLICATION.

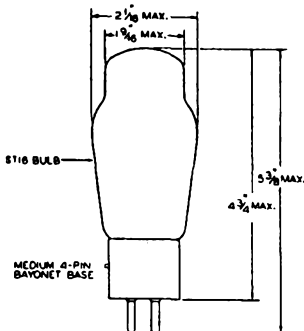

Top View of Socket Connections

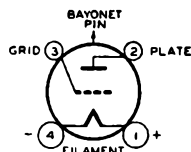

# RCA-1609

## Amplifier Pentode

(Low-microphonic design)

RCA-1609 is a pentode of the coated filament type for use as an audio-frequency amplifier in battery-operated installations critical as to microphonics.

### TENTATIVE CHARACTERISTICS

Filament Volts (d-c) .....	1.1	Grid-Plate Capacitance .....	1.1 $\mu\text{f}$
Filament Amperes .....	0.25	Input Capacitance .....	6.7 $\mu\text{f}$
		Output Capacitance .....	7 $\mu\text{f}$

### As Audio-Frequency Amplifier—Class A<sub>1</sub>

D-C PLATE VOLTAGE .....	135 <i>max.</i>	Volts
D-C SCREEN VOLTAGE (Grid No. 2).....	67.5 <i>max.</i>	Volts
D-C GRID VOLTAGE (Grid No. 1).....	-1.5	Volts
D-C PLATE CURRENT .....	2.5	Milliamperes
D-C SCREEN CURRENT .....	0.65	Milliampere
PLATE RESISTANCE (Approx.) .....	0.4	Megohm
AMPLIFICATION FACTOR (Approx.) .....	300	
TRANSCONDUCTANCE .....	725	Micromhos

### INSTALLATION AND APPLICATION

The base pins of the 1609 fit the standard 5-contact socket which should be mounted to hold the tube in a vertical position. If it is necessary to place the tube in a horizontal position, it should be mounted with the plate in a vertical plane (on edge).

The coated filament is designed for operation from dry-cells, or from a single lead storage cell. The filaments of 1609's should preferably be connected in parallel although it is permissible to operate several of these types in series provided the rated filament current of 0.25 ampere is maintained.

When the input circuit of the 1609 is resistance-coupled, the resistance in the grid circuit should not exceed 0.5 megohm for fixed-bias conditions.

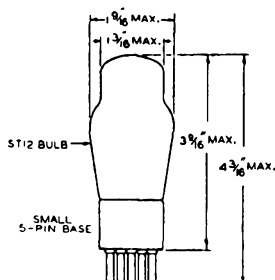
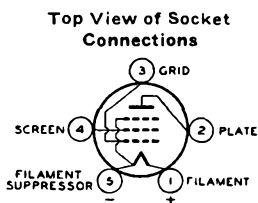

# RCA-1610

## Crystal-Oscillator Pentode

RCA-1610 is a filament type of pentode intended particularly for use as a crystal oscillator. The 1610 may be operated at maximum ratings at frequencies as high as 20 megacycles. The maximum plate dissipation for class C service is 6 watts.

### TENTATIVE CHARACTERISTICS AND RATINGS

Filament Volts (a-c or d-c).....	2.5	Grid-Plate Capacitance .....	1.2 $\mu\text{f}$
Filament Amperes .....	1.75	Input Capacitance .....	8.6 $\mu\text{f}$
Transconductance (For plate current of 31 ma.) Micromhos .....	2500	Output Capacitance .....	13 $\mu\text{f}$

### As R-F Power Amplifier and Oscillator—Class C Telegraphy

*Key-down conditions per tube without modulation††*

D-C PLATE VOLTAGE .....	400	max. Volts
D-C SCREEN VOLTAGE .....	200	max. Volts
D-C GRID VOLTAGE .....	-100	max. Volts
D-C PLATE CURRENT .....	30	max. Milliamperes
D-C GRID CURRENT .....	3	max. Milliamperes
PLATE INPUT .....	9	max. Watts
SCREEN INPUT .....	2	max. Watts
PLATE DISSIPATION .....	6	max. Watts

#### TYPICAL OPERATION:

D-C Plate Voltage .....	300	400	Volts
D-C Screen Voltage .....	125	150	Volts
D-C Grid Voltage .....	-60	-50	Volts
Peak R-F Grid Voltage .....	110	75	Volts
D-C Plate Current .....	30	22.5	Milliamperes
D-C Screen Current .....	13	7	Milliamperes
D-C Grid Current (Approx.) .....	2.5	1.5	Milliamperes
Screen Resistor .....	13500	35000	Ohms
Driving Power (Approx.) .....	0.25	0.1	Watt
Power Output (Approx.) .....	5	5	Watts

†† Modulation essentially negative may be used if the positive peak of the audio-frequency envelope does not exceed 115% of the carrier conditions.

### INSTALLATION AND APPLICATION

The base pins of the 1610 fit the standard 5-contact socket which should be installed preferably to hold the tube in a vertical position.

As a crystal-controlled oscillator, the 1610 should be operated with a grid-leak resistance of approximately 30,000 ohms (1-watt rating). When the tube is used as an oscillator, the screen voltage should be obtained from a fixed supply or from a potentiometer connected across the plate-voltage supply.

For high-frequency operation above 20 megacycles, see page 144.

For additional information, see chapters on INSTALLATION and APPLICATION.

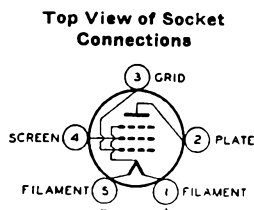
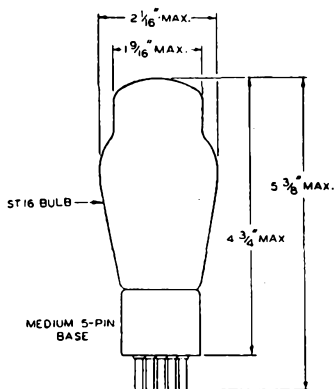

# Transmitting-Tube Ratings

## HOW RATINGS ARE DETERMINED

During the development of an RCA tube, tentative designs are constructed to meet desired ratings. For these designs, the materials chosen, the dimensions used, and the structures employed are based on the chemical and physical properties of materials, our research work, and the experience of our engineers with other tube types, both in the laboratory and in the field. Sample tubes of the new designs are then checked for compliance with the desired ratings and characteristics. Destructive overload tests are made to determine if there is a reasonable margin of safety in the designs. Life tests, however, are most important of all in the selection of the final design and the determination of final ratings. Groups of tubes are placed on life-test racks and operated under maximum rated conditions. At intervals they are removed for electrical measurements, but life testing is continued until the tubes fail. When the life tests indicate that the design is satisfactory for good tube performance at the tentative maximum ratings, these ratings are established for the tube type.

If the results of life tests on a large number of tubes of a given type are examined, some interesting facts will be found. The curve in Fig. 6 shows what

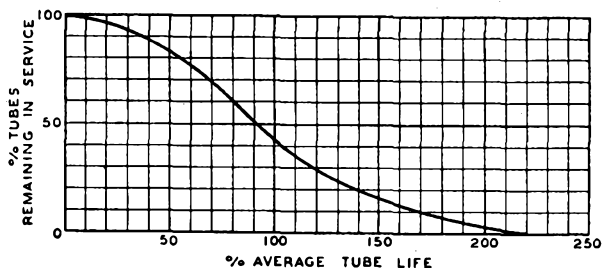

Fig. 6

occurs. The rate of tube failures is low initially, but after a prolonged period increases rather rapidly for a while. Finally, the rate again becomes low and a few tubes give an exceedingly long life. This curve is typical of many mortality relationships, and is particularly comparable to the human mortality curves from which life insurance companies compute their rates. It is apparent that although the life of a single tube, even under rigidly specified conditions, cannot be predicted, the average life of a group of tubes can be predicted when the tubes are operated under rated conditions. Therefore, if the operation of tubes is confined within well-established ratings, satisfactory service and life can be expected.

## CONSIDERATIONS INFLUENCING RATINGS

When a tube is manufactured, it is not known in what field of radio service it will be used. Accordingly, ratings must be established so that the tube will give long, reliable service in any field. Long tube life is capable of a number of interpretations, depending on the viewpoint of the user. A broadcasting station, for example, operates tubes on an average of 18 hours a day. Tube failures are

expensive both in themselves and in advertising revenue lost because of interrupted programs. Consequently, the broadcaster insists that his tubes operate for more than a thousand hours without failures. Reliability is the keyword.

On the other hand, aviation companies often operate transmitting tubes only 15 minutes each day. On this basis, a tube life of 1000 hours would seem unnecessary. However, it is imperative that the tubes be ready for operation when necessary, because failures at the wrong moment may mean damage to an expensive airplane or even loss of human life. Again, reliability is the keyword.

The radio amateur has different requirements. He does not usually demand the full measure of reliability that some other services require, nor, relatively speaking, does he require the extremely long tube life needed by others. It has been estimated that the average amateur transmitter is in operation 300 hours, or less, a year. On an average, therefore, an amateur requires at least  $3\frac{1}{2}$  years to obtain a thousand hours of operation from his transmitting tubes. Because of this, amateurs may feel that they can overload their tubes a certain amount, shorten the life to one year, and thus obtain economy in the operation of their stations (on the basis that an overloaded small tube can be made to do the work of a larger and more expensive type). The flaw in this reasoning is that not even the manufacturer can predict how much overloading an individual tube will stand and yet give a desired fraction of its probable life under normal operating conditions. A tube costing \$5 which delivers an output of 100 watts for 300 hours is not as economical as a larger tube costing \$10 which delivers an output of 100 watts for 1000 hours. Furthermore, there is no guarantee that the overloaded \$5 tube will give even 30 per cent of its probable normal life. The important conclusion for almost all users of transmitting tubes is that it is highly desirable to operate them within the manufacturer's ratings.

## INTERPRETATION OF TUBE RATINGS

A thorough understanding of the significance of published ratings is necessary if optimum results are to be obtained. The following explanation is intended to clarify the meaning of the ratings tabulated under each individual tube type.

The filament or heater voltage given in the tabulations is a normal value unless otherwise stated. Transformers and resistances in the filament circuit should be designed to operate the filament or heater at the rated value for full-load operating conditions with an average line voltage. Variations from the rated value due to line-voltage fluctuations or other causes should not exceed plus or minus 5 per cent, unless otherwise stated under the tube type.

In general, the filament of a transmitting tube may be operated with either an a-c or a d-c supply. An a-c source is usually employed because of its convenience and economy, unless a d-c source is necessary to avoid hum. With a-c operation, the grid return and the plate return should be connected to the mid-point of the filament circuit. This point may be the center tap of the filament winding or of a low resistance shunted across the filament circuit. When direct current is used, the return leads should be connected to the negative filament terminal.

Where it is found desirable to use d-c filament excitation on any filament-type tube for which data are given on an a-c basis, the grid-bias values as shown in

the tabulated data should be decreased by an amount equal to approximately one-half the rated filament voltage. The grid-bias voltage should be measured from the negative filament terminal.

In the rating of RCA transmitting tubes, certain tabulated values are given as maximum. These are limiting values above which the serviceability of the tube will be impaired from the standpoint of life and satisfactory performance. If these limiting values are not to be exceeded, it is necessary to determine the amount of voltage fluctuation due to line-voltage variation, load variation, and manufacturing variation in the apparatus itself. Average design values can then be chosen so that the maximum ratings will never be exceeded under the usual operating conditions.

Each maximum rating should be considered in relation to all other maximum ratings, so that under no condition of operation will any maximum rating be exceeded. If the product of the maximum rated plate voltage and d-c plate current exceeds the maximum rated d-c plate input, then either or both the plate voltage and plate current should be reduced an appropriate amount. For example, the 808 in class C telegraphy service has the following ratings: 1500 max. plate volts; 150 max. plate milliamperes; and 200 max. d-c plate input watts. It is apparent that when the maximum plate voltage of 1500 volts is used, the d-c plate current must be reduced so that the maximum d-c plate input will not be exceeded. If the maximum plate current of 150 milliamperes is used, then the plate voltage should be reduced accordingly.

The data tabulations also show typical operating values for each respective tube type in the classes of service for which the tube is recommended. These values should not be considered as ratings, because the tube can be used under any suitable conditions within its maximum ratings, according to the application. The output value for any operating condition is an approximate tube output—that is, plate input minus plate loss. Circuit losses must be subtracted from tube output in order to determine the useful output. Output values are approximate and are not to be considered as output ratings. The actual output in any case depends on a number of variable factors, important among which are circuit efficiency and operating frequency.

## TRANSMITTING-TUBE RATINGS VERSUS OPERATING FREQUENCY

Because circuit and tube losses increase with frequency, it is apparent that for each tube type there will be a limiting maximum frequency above which the tube cannot be expected to operate safely within its maximum power dissipation ratings when the maximum rated d-c plate input is employed. However, safe operation can be obtained at the higher frequencies if the d-c plate voltage and power input are appropriately reduced. The following table lists the recommended operating conditions in per cent of maximum rated plate volts and d-c plate input. For frequencies between the tabulated values, interpolation may be employed. For example, in the case of an 800 operating at 80 megacycles, the maximum d-c plate voltage and input that should be used are 87 per cent of the maximum rated values shown in the tabulated data for any given class of service. The maximum plate voltage for class C telegraphy service at 80 megacycles is 1090 volts (approximately), this being 87 per cent of the maximum rated value of 1250 volts. The maximum rated d-c plate current may remain the same.

In the fifth column of the accompanying table are given the resonant frequencies of the tubes alone. Each of the resonant values is obtained with the shortest practical connection between grid and plate.



## TRANSMITTING TUBE RATINGS VERSUS OPERATING FREQUENCY

Tube Type	Max. Freq. for 100% Max. Rated Plate Volts & Plate Input	Max. Freq. for 75% Max. Rated Plate Volts & Plate Input	Max. Freq. for 50% Max. Rated Plate Volts & Plate Input	Resonant Frequency of Tube Only
	Megacycles	Megacycles	Megacycles	Megacycles
203-A	15	30	80	100
204-A	3	10	30	50
211	15	30	80	100
800	60	100	180	300
801	60	75	120	170
802	30	55	110	150
803	20	35	70	115
804	15	35	80	140
805	30	45	85	115
806	30	50	100	197
807	60	80	125	155
808	30	60	130	272
809	60	70	100	140
814	30	50	100	190
830-B	15	30	60	90
831	20	30	60	100
833	See curve under this type			—
834	100	170	350	500
837	20	35	80	125
838	30	50	120	140
841	6	45	170	170
843	6	50	200	200
844	8	45	155	155
849	3	10	30	40
850	13	35	100	130
851	3	7	15	28
852	30	70	120	210
860	30	70	120	195
861	20	30	60	100
865	15	30	70	125
1602	6	45	170	170
1608	45	70	150	150
1610	20	110	—	215

# Transmitter Design Considerations

## CHOICE OF TUBE TYPES

In the design of a radio transmitter, the choice of the number and types of transmitting tubes is of paramount importance. Engineers, radio amateurs, and others interested in transmitter design are fortunate in having available a large variety of power tubes with which to work. The very number of tube types may even seem to be a source of confusion, but the problem, if approached logically, represents no great difficulty. The designer can, by the simple process of elimination, reduce the number of tube types suitable for a specific application to a small group from which a final choice can readily be made.

Most modern transmitters are of the crystal-oscillator power-amplifier type. In almost every case, however, the ultimate design revolves around the final stage—the r-f power amplifier which develops useful r-f energy and supplies it to the radiating system. The following considerations are important in the choice of power tubes for the final amplifier stages: (1) power capability, (2) frequency capability, (3) design suitability, and (4) economic suitability.

**Power capability.** The tube or tubes used in the r-f power amplifier should be capable of delivering the desired power output when operated (with a practicable value of efficiency) within the maximum ratings. The efficiency of the final stage depends on a number of factors, chief of which are the class of amplification and the operating frequency. Typical efficiencies to be expected in the various classes of amplification are given in the chapter on TRANSMITTING-TUBE APPLICATION.

**Frequency capability.** The final amplifier tube or tubes should be capable of operating at the desired radio frequency with sufficient d-c plate input so that, with a practicable value of efficiency, the required power output can be obtained. In this connection, the table TRANSMITTING TUBE RATINGS vs. OPERATING FREQUENCY is valuable. The problems introduced by the operating frequency are increasingly important as the frequency becomes higher.

**Design suitability.** Under this broad heading is included a large number of miscellaneous factors which the designer should consider. Some of these are:

(1) **Power supply.** This factor is important in the choice of tube types. In portable designs, it may be necessary to use tubes which can be economically operated from a heavy-duty, low-voltage battery supply. In fixed-station service, where a source of a-c power is available, the problem of d-c voltage supplies is greatly simplified through the use of suitable rectifiers and filters.

(2) **Power sensitivity.** In those cases where the total number of stages in a transmitter must be kept to a minimum, tubes having high power sensitivity should be employed. Power pentodes and beam power tubes, such as the 803, 807, and 814, require very little driving power compared to triodes of equivalent power output. For low-power frequency multipliers and intermediate amplifier stages, the 802 pentode and the 807 beam power amplifier are very useful.

(3) **Circuit flexibility.** Where a transmitter must be capable of operating on a number of widely different frequencies with a minimum of time required for changing frequencies, the use of tetrodes or pentodes (in preference to triodes) is indicated. Because tetrode and pentode amplifiers do not, in general, require neutralization, the problems that are sometimes encountered with neutralized triode amplifiers are avoided.

(4) Mechanical considerations. The size and shape of the tube may be important in some transmitter designs because of space or weight requirements. The arrangement of the electrode terminals is sometimes of importance because it affects circuit wiring and the mounting of circuit components.

(5) Electrical considerations. It is frequently convenient to use certain tube types together because they can be operated from a common filament supply, from a common plate-voltage source, or because they make practical other simplifications in design and maintenance.

**Economic suitability.** This factor includes not only initial tube cost but also the costs of auxiliary equipment, maintenance, and operation. An analysis of these costs will often indicate that it is desirable to modify the design to meet the requirements of a particular installation.

Most of these considerations have dealt with the choice of tube type for the r-f power amplifier stage. Where modulated service is contemplated, additional factors which influence the choice are introduced: these, however, are explained in the chapter on TRANSMITTING-TUBE APPLICATION.

An important problem in transmitter design is the choice of tube types for the intermediate amplifier, multiplier (if any), and oscillator stages. In practice, it is generally convenient to begin with the r-f power amplifier stage and work "backward", toward the master or crystal-oscillator stage. The driving power necessary for the final tube (or tubes) can be obtained, for a specified class of service, from the tabulated tube data. This power, as shown for triodes and tetrodes in class B r-f service and in class C service, is subject to wide variations, depending on the impedance of the output or load circuit. High-impedance load circuits require more driving power to obtain the desired output. Low-impedance circuits need less driving power, but cause a sacrifice of plate-circuit efficiency.

The driver stage should have a tank circuit of good regulation and should be capable of delivering considerably more than the rated driving power of the final amplifier tube. For example, if the final amplifier has a rated driving power of 10 watts in class C telegraphy service, the driver stage may have to be capable of delivering 15 to 25 watts of r-f power in order to compensate for circuit losses and to have suitable regulation. The actual value will depend on several variable factors, so that some actual experience is frequently necessary before the designer of a transmitter can choose the most logical tube type for the driver stage. In general, however, it is advisable to have available some surplus driving power, because class C amplifiers do not operate efficiently when under-excited. An important advantage of pentodes and beam power tubes is that they require very little driving power, so that the choice of a suitable driver stage for such tubes usually presents no great problem. In most cases, the driver should be operated as an amplifier rather than as a plate-circuit multiplier, because the efficiency and power output of the latter are relatively low.

The choice of tube types for the stages preceding the last intermediate amplifier depends, of course, on considerations of frequency and power. A typical arrangement for a high-frequency, multi-stage transmitter includes a crystal-controlled oscillator and one or more frequency-multiplier stages. Examples of such transmitters are shown in the CIRCUIT SECTION. The number of multiplier stages (usually frequency doublers) depends on the frequency of the crystal and on the desired operating frequency. In many cases, special oscillator circuits are used so that frequency multiplication initially takes place in the oscillator stage itself. These circuits usually reduce the number of multiplier stages necessary to reach a specified operating frequency with a crystal whose fundamental frequency is a sub-harmonic of the operating frequency.

Pentodes and beam power tubes, such as the 802 and 807, respectively, are very useful as frequency multipliers and low-power intermediate amplifiers. These tubes, when used in properly designed and shielded circuits, ordinarily require no neutralization in r-f amplifier service. This advantage is very worthwhile in multi-stage transmitters which necessarily require numerous controls and adjustments. The last intermediate amplifier is often driven by the last frequency-doubler stage. This arrangement is quite satisfactory provided the output of the doubler is sufficient to excite adequately the amplifier stage.

### GRID-BIAS CONSIDERATIONS

There are three general methods of obtaining negative grid bias for vacuum-tube amplifiers. Not all of these methods are suitable for every class of service, as explained in TRANSMITTING-TUBE APPLICATION. The three methods are: (1) fixed source, (2) grid-leak resistor, and (3) cathode resistor (self-bias).

Fig. 7 illustrates the use of fixed bias in several types of r-f amplifier circuits. The voltage source may be a battery, a d-c generator, or a rectifier designed to

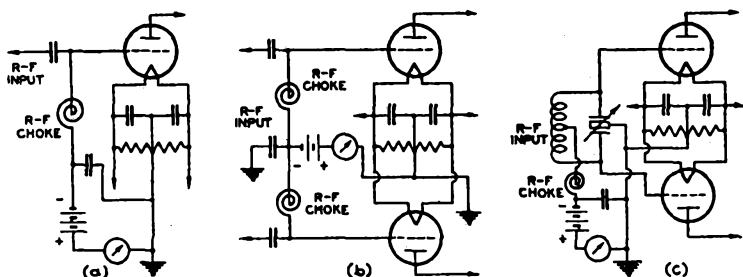

CONNECTIONS FOR FIXED BIAS SUPPLY

Fig. 7

have good regulation. An r-f choke and by-pass condenser serve to exclude the r-f grid voltage from the bias-voltage supply. Where a tuned grid circuit is employed, the r-f choke is often not essential and may sometimes even be detrimental to the operation of the circuit. An r-f choke of the wrong value in the grid circuit may cause trouble from parasitic oscillations, especially where a similar r-f choke is used in the plate circuit. A bias voltage from a fixed source serves to protect the tube against accidental removal of the r-f grid excitation, provided the bias is large enough to reduce the d-c plate current to cut-off, or to a low value.

Fig. 18 in the CIRCUIT SECTION shows a typical grid-leak-biased stage. In this circuit, the RCA-808 receives its entire negative grid bias from grid-leak resistor  $R_5$ . The value of the grid leak is determined by Ohm's law,  $R = E/I$ , where  $R$  is in ohms,  $E$  is the negative grid bias (in volts) recommended for the particular class of service contemplated, and  $I$  is the value of d-c grid current (in amperes) shown under typical operation in the tabulated data. In the example given, the grid bias and d-c grid current are  $-210$  volts and  $35$  milliamperes, respectively. Thus,  $R = 210/0.035 = 6000$  ohms, the value specified for  $R_5$ . If two tubes are used in parallel or in push-pull, the d-c grid current of both tubes may flow through a common grid leak. In this case, the value of the grid-leak resistance will be one-half that for a single tube.

The grid-leak bias method has the advantage of simplicity and of automatically biasing the grid in proportion to the excitation voltage available. Because of this automatic action, the bias voltage developed across a grid leak is not critically dependent on the value of the grid-leak resistance. Therefore, considerable variation in the resistance of the leak can usually be tolerated. Special care must be observed when grid-leak bias is used because accidental removal of the r-f grid excitation will cause the grid bias to fall to zero and (in the case of a tube having a low or medium amplification factor) the plate current to rise to an excessive value. The use of a protective device designed to remove the plate voltage (and screen voltage, in the case of tetrodes and pentodes) on excessive rises of plate current will minimize the danger of destructive overloads (see PROTECTIVE DEVICES).

Fig. 8 illustrates the use of cathode-resistor bias. In these circuits, the cathode current flowing through  $R_k$  builds up a voltage drop which makes the cathode positive with respect to ground. Since the grid is at ground potential with respect to all d-c voltages, the grid is biased negatively with respect to the cathode. The cathode current for triodes is the sum of the d-c plate current and the d-c grid current. For tetrodes and pentodes, the screen current must also be added.

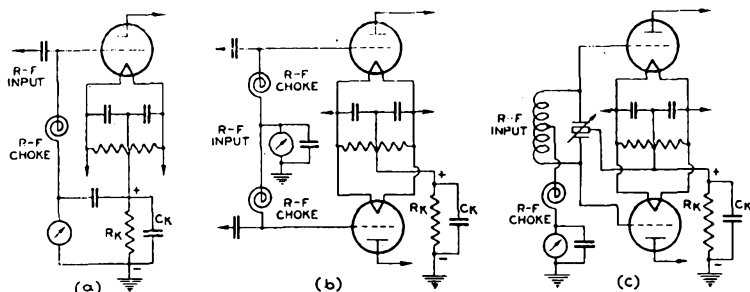

CONNECTIONS FOR CATHODE-RESISTOR BIAS SUPPLY

Fig. 8

Cathode-resistor bias, or self-bias, is advantageous in that it tends to protect the tube against heavy d-c plate-current overloads; that is, when the plate current increases, the bias voltage across the cathode resistor also increases so that the rise in plate current is automatically opposed. A disadvantage of self-bias is that the effective d-c plate voltage is reduced by the amount of the bias voltage. Thus, the voltage output of the plate supply must equal the desired plate voltage plus the required bias voltage.

The value of cathode resistor  $R_k$  can be determined by Ohm's law,  $R = E/I$ , where  $R$  is in ohms,  $E$  is the required bias in volts, and  $I$  is the total cathode current in amperes. For example, assume that the total d-c plate current (under normal load) is 100 milliamperes, that the total d-c grid current is 20 milliamperes, and that the required bias is  $-240$  volts. Then,  $R_k = 240/0.120 = 2000$  ohms. The power dissipated by  $R_k$  is equal to  $EI$ , or  $(240)(0.120) = 28.8$  watts. A 50-watt resistor is a logical choice, because it is desirable to operate a resistor at less-than-rated power in order to provide a suitable factor of safety.

Where two or more filament-type tubes are individually self-biased, the use of a separate cathode resistor and a separate filament-supply winding is necessary for each tube so biased (see Fig. 9). This arrangement provides a method of adjusting individually the bias of each tube in a push-pull amplifier stage.

Various combinations of biasing methods are sometimes desirable. Fig. 18 in the CIRCUIT SECTION shows a combination of grid-leak bias and self-bias in the second 807 stage. Part of the bias is supplied by  $R_4$  in the cathode circuit. The remainder is furnished by the grid leak  $R_3$ . This method reduces the

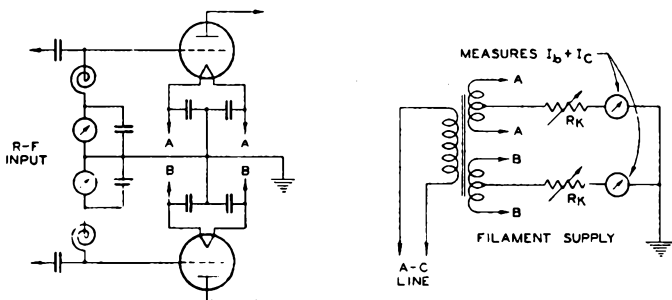

CONNECTIONS FOR INDIVIDUALLY-BIASED TUBES USING THE CATHODE-RESISTOR METHOD.

Fig. 9

magnitude of plate-current overloads due to loss of grid-leak bias when the r-f grid excitation fails. In addition, the loss in d-c plate voltage (caused by the drop across the cathode resistor) is less than in the method employing self-bias alone. Fig. 17 (CIRCUIT SECTION) illustrates the use of grid-leak bias with fixed bias. Sufficient fixed bias is used to reduce the d-c plate current to a low value when no r-f grid excitation is applied (as when the oscillator is keyed, or accidentally goes out of oscillation). The grid leak furnishes enough additional bias, under normal operating conditions, to provide the total bias voltage required. In a plate-modulated amplifier, the use of grid-leak bias combined with either cathode bias or fixed bias improves the linearity of the amplifier and thereby reduces distortion in the audio component of the modulated carrier.

### INDUCTANCE AND CAPACITANCE FOR TUNED CIRCUITS

The performance of a transmitting tube definitely depends on the characteristics of the circuit in which it is used. Because parallel-tuned circuits are almost universally employed for the plate, or output, circuit of vacuum-tube r-f amplifiers, except at ultra-high radio frequencies, considerations involving inductance (L) and capacitance (C) are very important in transmitter design.

The resonant frequency of the parallel-tuned circuits used in transmitters is given by the relation,

$$f = \frac{10^6}{2\pi\sqrt{LC}} \tag{1}$$

where  $f$  is frequency in kilocycles per second (kc)

L is inductance in microhenrys ( $\mu\text{h}$ )

C is capacitance in micro-microfarads ( $\mu\mu\text{f}$ )

This relation can be further simplified, so that

$$f = \frac{159160}{\sqrt{LC}} \quad \text{or} \tag{2}$$

$$L = \frac{(159160)^2}{f^2C} = \frac{25.33 \times 10^9}{f^2C} \tag{3}$$

Equation (3) can be used to determine the inductance necessary to tune to a specified frequency  $f$  with a known value of capacitance  $C$ . The product of  $L$  and  $C$  is a constant for a given frequency; the frequency of a resonant circuit varies inversely as the square root of the product of inductance and capacitance. Doubling both  $L$  and  $C$  halves the resonant frequency; reducing both  $L$  and  $C$  to one-half doubles the frequency. In actual circuits, of course, the effect of stray inductances and capacitances of the circuit wiring and of the tubes must be taken into account, especially at the higher radio frequencies.

The value of  $L$  and  $C$  should be chosen with considerable care. Because an r-f amplifier tube supplies power only during a fraction of each cycle, the tank circuit must function as a "fly-wheel" to carry on the oscillation to the next plate-current pulse. A measure of this fly-wheel effect is the ratio of volt-amperes in the tank circuit to the power delivered by the tube. This ratio is defined as the operating  $Q$ .

It is common practice to employ an operating  $Q$  of 10 to 15 for either telegraphy or telephony service. If the value of  $Q$  is much lower, there will be considerable distortion of the r-f waveform with resultant power output at harmonic frequencies. Harmonic output from the power amplifier is very undesirable because it represents wasted power and may lead to radiation at harmonic frequencies which will cause interference to other radio services. A value of  $Q$  which is too high will result in excessive losses in the tank circuit due to the large circulating r-f current in a high- $Q$  circuit. This condition is evidenced by high plate current even when the tank circuit is not loaded. Other factors being equal, the  $Q$  is proportional to the tuning capacity in the tank circuit. The capacitance needed for the tuned circuit of an r-f amplifier can be determined approximately from the following relation:

$$C = \frac{300QI_b}{fE_b} \quad (4)$$

where  $Q$  is a constant (about 10 to 15)

$I_b$  is the total d-c plate current in milliamperes

$f$  is the frequency in megacycles

$E_b$  is the d-c plate voltage in volts

$C$  is the total capacitance, in micro-microfarads ( $\mu\mu f$ ), placed across the tank inductance.

This value of  $C$  is for an amplifier of the single-ended type employing a tank circuit which is not split. It is the capacitance in actual use and not the maximum capacitance of the tank condenser. The value of  $C$  determined from equation (4) represents a minimum value; a slightly larger value can usually be used without appreciable reduction in power output.

Where a single-ended stage is used with a split tank circuit, the value of  $C$  (the total capacitance across the inductance) should be one-fourth that given by equation (4). The corresponding tank inductance should be approximately four times that employed in a tank circuit which is not split, in order to keep the product of  $L$  and  $C$  the same. For a push-pull stage of the same power input, the value of  $C$  is also but one-fourth that given by the formula. Because the condenser used in a push-pull stage is generally of the split-stator type, each section of the condenser should have a capacitance equal to one-half that given by equation (4). The factor  $I_b$  used in the equation is the total d-c plate current of the amplifier stage, regardless of how many tubes may be used in parallel or in push-pull.

For amateur-station design purposes, an operating  $Q$  of 12 is satisfactory for either telegraphy or plate-modulated telephony service. The chart shown in Fig. 10, based on a  $Q$  of 12, presents a simple method of determining the value of  $C$ . Similar charts, prepared by Mr. John L. Reinartz, are shown in his article "How Much C?", published in QST for March, 1937.

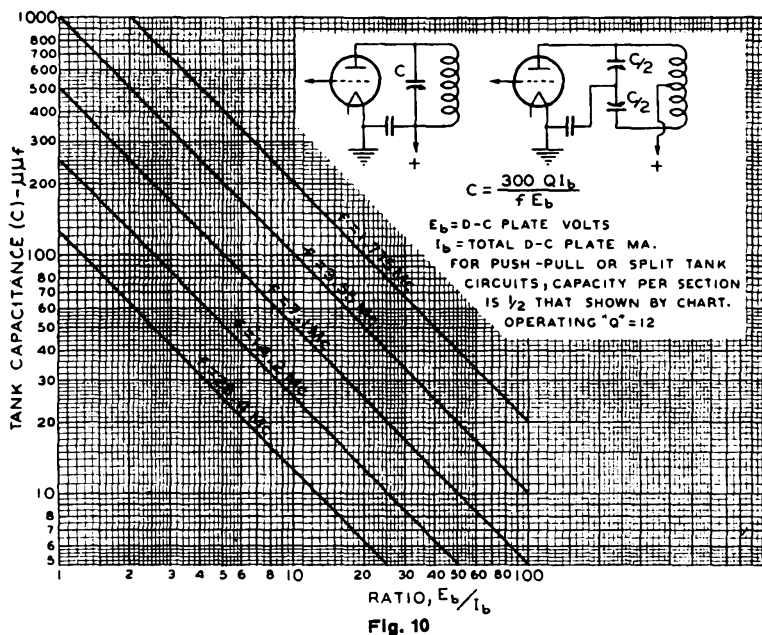

Knowing the frequency and the capacitance required, the designer can quickly determine the proper value of inductance in microhenrys from equation (3). In order to determine the approximate design of a single-layer coil to give the desired inductance, the chart shown in Fig. 11 can be employed as indicated in the following example.

Assume that the desired coil is to be wound with 3/16-inch copper tubing spaced 3 turns to the inch and is to have an inductance of 4.5 microhenrys ( $\mu\text{h}$ ). Then, from the equation

$$L = L_o N^2, \text{ or } L_o = \frac{L}{N^2}, \tag{5}$$

it is found that  $L_o = 4.5 / (3)^2 = 0.5 \mu\text{h}$ . Applying this value of  $L_o$  to the chart, we find that a coil  $2\frac{1}{2}$  inches in diameter should be about 4.2 inches long to give the proper inductance. The total number of turns necessary is  $4.2 N$ , or  $(4.2) (3) = 12.6$  turns. The length of the coil for other diameters can readily be found from the chart, and the total number of turns determined by multiplying the length by  $N$ , the number of turns per inch.

The chart can be used equally well to find the inductance of a coil of known specifications. For example, it is desired to determine the inductance of a coil  $2\frac{1}{2}$  inches in diameter wound with 90 turns of No. 24 D.C.C. wire. The wire tables show that this size of wire has a winding factor of 33.6 turns per inch,



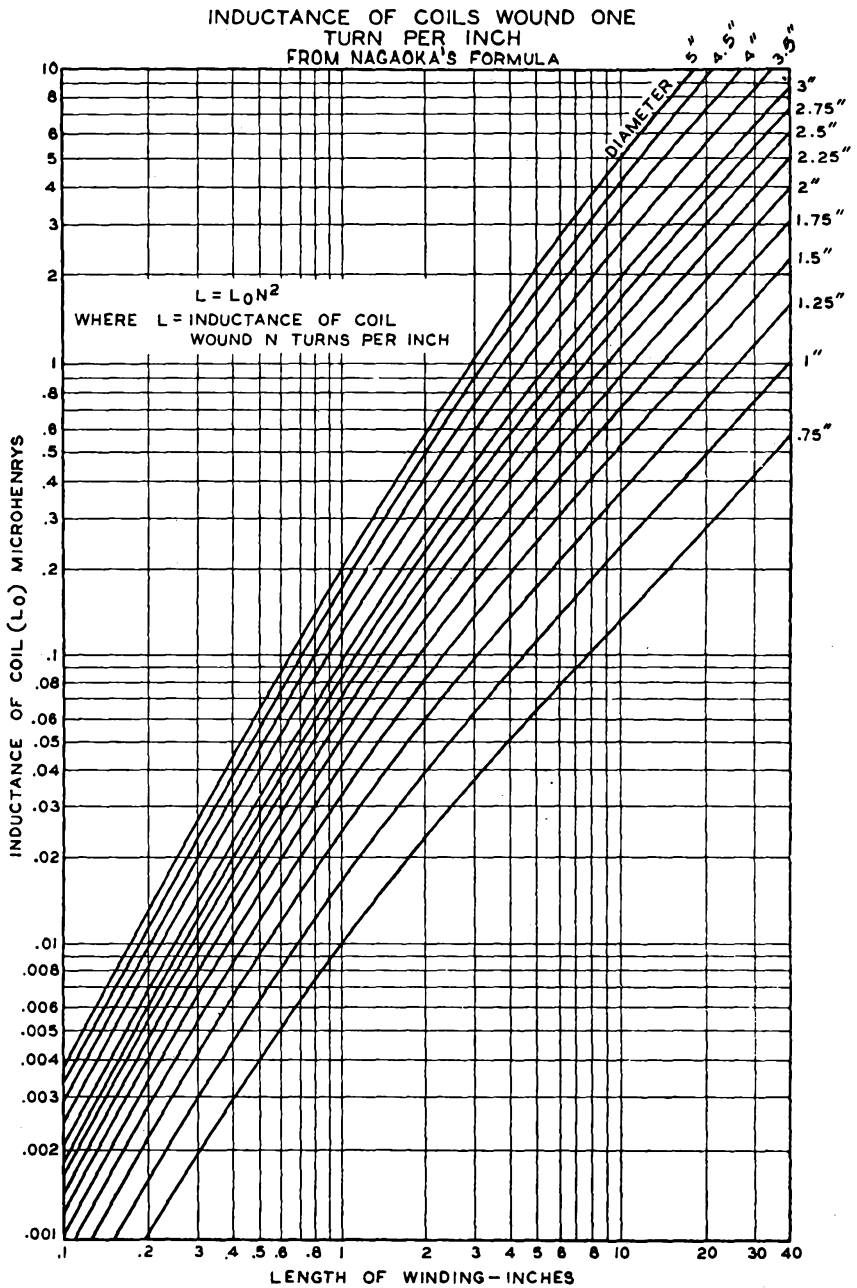

Data by courtesy of Electronics

Fig. 11

from which the length of the coil is found to be  $90/33.6 = 2.68$  inches. From the chart,  $L_0$  is found to be about  $0.29 \mu\text{h}$  for a  $2\frac{1}{2}$ -inch coil 2.68 inches long. Because  $L = L_0 N^2$ , the inductance of the coil is  $(0.29)(33.6)^2$ , or  $327 \mu\text{h}$  (approximately).

## INTERSTAGE COUPLING

In transmitter design, the coupling of the r-f amplifier grid circuit to the plate circuit of the driver stage is of considerable importance. In most cases, the amplifier grid is driven so that grid rectification occurs and, as a result, a direct current flows in the amplifier grid circuit. The amount of d-c grid current and driving power required depend principally on the tube type used in the amplifier, the class of service, the operating frequency, and on the plate load impedance of the amplifier. Where considerable power must be transferred from the driver to the amplifier, the interstage coupling system should be capable of transferring this power efficiently.

There are two general methods of coupling r-f stages, namely, capacitive and inductive. The latter method may consist of two directly coupled inductances, or of two inductances indirectly coupled through a low-impedance transmission line.

An example of capacitive interstage coupling is shown in Fig. 14 in the **CIRCUIT SECTION**. The grid condenser should be connected to a tap on the plate inductance of the driver stage. This tap should be chosen so that the required peak r-f voltage is applied to the grid of the amplifier tube. The higher the peak r-f voltage required, the closer the excitation tap should be placed to the plate end of the driver tank. This coupling method has the advantage of extreme simplicity, because it requires a minimum of parts and of circuit adjustments. It has the disadvantage that the use of a tap on the driver plate tank may form auxiliary tuned circuits which invite spurious, parasitic oscillations.

Direct inductive coupling between the driver plate tank and the amplifier grid tank provides an efficient coupling system. The grid circuit of the amplifier may be either tuned or untuned, the former being more efficient but more critical of adjustment. This system has the disadvantage that more circuit parts and adjustments are necessary than with capacitive coupling. In addition, the driver and the amplifier must necessarily be placed close together due to the importance of short leads at radio frequencies.

The advantages of inductive coupling can be retained, without the necessity of the coupled stages being in close proximity, by means of a low-impedance transmission line. The most common form, known as "link coupling," consists of two tuned circuits coupled by means of a twisted pair terminated at each end by a coupling coil of a few turns. This system is capable of transferring power efficiently and permits the amplifier to be placed at a considerable distance from the driver stage. Link coupling has the disadvantage of requiring additional circuit parts and adjustments, and is not particularly flexible where operation on several widely different frequencies is required. The coupling "links" should always be coupled to the associated tuned circuits at a point of zero or low r-f potential. Examples of link coupling are given in the **CIRCUIT SECTION**.

Other types of transmission lines can be used if desired. Two-wire spaced lines are more efficient than ordinary twisted pair, but are more difficult to handle and require more space. Co-axial-cable lines are most efficient, but, if made of considerable length, are costly and in many cases rather inflexible. Co-axial lines are, therefore, little used for coupling between stages.

For additional information on interstage coupling, see references No. 14 and No. 23 in the **READING LIST**.

## NEUTRALIZING

A triode used as an r-f amplifier will oscillate because of r-f feedback through the grid-plate capacitance of the tube, unless the effect of this feedback is eliminated. In tetrodes and pentodes, the grid-plate capacitance is practically eliminated by means of a screen grid placed between the grid and the plate. Feedback between grid and plate in a triode is nullified by a circuit arrangement which takes some of the r-f voltage from one circuit and feeds it back into the other circuit so that it effectively cancels the r-f voltage operating through the grid-plate capacitance of the tube. This procedure, known as **neutralization**, makes it impossible for a triode to operate in a self-excited condition. For proper neutralization, the neutralizing voltage must be opposite in phase and equal in amplitude to the feedback voltage between the grid and the plate.

A typical grid-neutralized circuit is shown in Fig. 12. In a balanced-input circuit of this type, the neutralizing condenser  $C_n$  should theoretically have a capacitance equal to the grid-plate capacitance ( $C_{gp}$ ) of the tube. Actually, however, the correct value for  $C_n$  may vary somewhat from the value of  $C_{gp}$ , due to the effects of stray capacitance in the circuit. The circuit from which the neutralizing voltage is obtained is sometimes not of the balanced type. If the tap on the coil is placed more than half the total number of turns from the "tube end," the capacitance required at  $C_n$  will increase about in proportion to the relative number of turns in the two portions of the coil. In most cases, it is desirable that  $C_n$  should have a small range which is adequate to extend beyond both sides of the calculated value, to take care of circuit and tube variations.

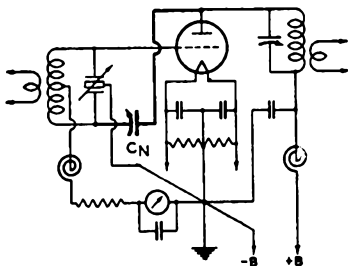

GRID-NEUTRALIZED CIRCUIT

Fig. 12

Two triodes in a push-pull circuit are neutralized by means of two neutralizing condensers connected in the so-called "criss-cross" circuit. The grid of each tube is connected through a neutralizing condenser to the plate of the other tube. Several illustrations of this arrangement are given in the **CIRCUIT SECTION**.

## Neutralizing Procedure

The technique in neutralizing an r-f amplifier is essentially the same irrespective of the type of tube or circuit employed. As the first step, the positive high-voltage plate lead should be disconnected from the amplifier. The filament of the tube should be lighted and the r-f grid excitation (from the driver stage) applied. Next, a fairly sensitive r-f indicator should be loosely coupled to the plate tank coil. Suitable r-f indicators are a neon bulb, a flashlight bulb or a thermogalvanometer connected in series with a one- or two-turn loop of insulated wire, a vacuum-tube voltmeter, or a cathode-ray oscillograph. The simple indicators are usually more convenient to use than the more complicated instruments. The plate tank circuit of the amplifier should be tuned to resonance, which will be shown by a maximum "reading" on the r-f indicator. The neutralizing condenser is now adjusted until the r-f indicator shows a minimum reading. This operation may detune the plate tank of the driver stage slightly, so that the latter should be carefully retuned to resonance. The plate tank of the amplifier should again be tuned to resonance. The r-f indicator will usually

show another maximum reading, but one of considerably less magnitude than the original reading. The neutralizing condenser is again adjusted for minimum (or zero) r-f indication. After this procedure has been repeated several times, a setting of the neutralizing condenser should have been found which shows no r-f voltage in the plate tank circuit of the amplifier. As the point of correct neutralization is more closely approached, the coupling of the r-f indicator will usually have to be tightened, because there is less r-f voltage available to operate the indicator. After each adjustment of the neutralizing condenser, the driver tank and the amplifier tank should be retuned to resonance. When the r-f indicator shows zero r-f voltage in the amplifier tank, the stage is properly neutralized. If a push-pull stage is to be neutralized, both neutralizing condensers should be adjusted simultaneously. They will not, however, always have exactly the same setting when neutralization is reached, because of slight differences in stray capacitances and because the tuned tank circuit may not be electrically symmetrical.

A very sensitive neutralizing indicator is a d-c milliammeter connected in the grid-return circuit of the amplifier which is being neutralized so as to measure rectified grid current. With the plate-voltage lead disconnected as before, the driver tank circuit is tuned until the d-c meter in the amplifier grid circuit shows a maximum reading. If the amplifier is not properly neutralized initially, tuning its plate tank circuit through resonance will cause the d-c grid current to vary. The neutralizing condenser should be adjusted slowly while the plate tank circuit of the amplifier is tuned gradually back and forth through resonance. As the point of correct neutralization is approached, the flicking of the needle of the d-c grid meter will gradually decrease in amplitude. If the amplifier is perfectly neutralized, tuning the plate circuit through resonance will not change the meter reading even slightly. During these adjustments, the driver plate circuit should occasionally be retuned to resonance, as indicated by a dip in its d-c plate current or by a maximum in the d-c grid current of the amplifier.

Because the rectified d-c grid current is a measure of the r-f excitation applied to the amplifier, the use of a d-c grid meter is usually advisable. The grid meter is not only useful for neutralizing adjustments, but it also provides a continuous check on the operation of the amplifier and the driver stage as well.

In some cases it may be found that, while a setting of the neutralizing condenser can be made which will give a definite minimum r-f indication, no adjustment will entirely eliminate r-f voltage from the tank circuit. This effect is sometimes due to stray coupling between the amplifier and driver plate tanks or to stray capacitances between various parts of the amplifier which tend to unbalance the neutralizing circuit. Adequate shielding between grid and plate circuits and between stages will often eliminate neutralizing difficulties. Shielding may actually cause trouble, however, if it is placed too close to the tuned circuits or to the neutralizing condensers. It is important that the ground lead from the rotor of a split-stator condenser be made direct (and as short as possible) to the filament circuit.

For additional information on neutralization, see references No. 14 and No. 23 in the READING LIST.

## OUTPUT COUPLING

There are numerous methods of coupling an r-f amplifier to an antenna or feeder system. The method best suited to a particular system depends on a number of factors which vary with different installations. Either capacitive or inductive coupling can be employed, regardless of whether the tank circuit of the final stage is of the balanced or unbalanced type.

**Capacitive coupling** has the advantage of simplicity, but does not attenuate harmonics which may be present in the output of the transmitter. The d-c blocking condenser should have a voltage rating high enough to take care of the peak plate voltage applied to the plate tank circuit.

**Inductive coupling** of the r-f amplifier to the antenna has many advantages and is often preferable to capacitive coupling. A well-designed inductive-coupling arrangement reduces the transfer of power at harmonic frequencies. In addition, inductive coupling effectively isolates the load circuit from the high d-c plate voltage, provides a flexible means of varying the load on the r-f amplifier, and, in conjunction with a low-impedance transmission line, permits the antenna tuning controls to be located at a distance from the transmitter.

When a tuned antenna tank circuit is inductively coupled to the tank circuit of the amplifier, the antenna coil should be coupled at a point of low r-f potential. This point is located at the "filament end" of a single-ended tank circuit and at the center of a split tank circuit of the balanced type. The popular "link" coupling arrangement employing a low-impedance transmission line is well suited for coupling to a balanced tank circuit. The turns ratio, primary to secondary, is equal to  $\sqrt{Z_p/Z_s}$ , where  $Z_p$  is the plate-circuit load impedance of the amplifier and  $Z_s$  is the impedance of the transmission line. This is a step-down ratio, because the impedance of the plate tank circuit is higher than that of the transmission line.

The plate-circuit load impedance  $Z_p$  can be determined approximately from the following relations:

$$Z_p = 500 E_b/I_b \quad (\text{for class C amplifiers})$$

$$Z_p = 250 E_b/I_b \quad (\text{for class B r-f amplifiers and for grid- or suppressor-modulated amplifiers})$$

where  $E_b$  is d-c plate voltage in volts

$I_b$  is d-c plate current in milliamperes

$Z_p$  is in ohms.

These values of  $Z_p$  are for unbalanced, single-ended output circuits. For split-tank or push-pull circuits, the values of  $Z_p$  as determined from the equations given above should be multiplied by four.\*

For additional information on output coupling methods, including circuits and design data, see references No. 14, No. 17, and No. 23 in the READING LIST.

## TUNING A CLASS C R-F AMPLIFIER

In general, the same adjustments are made in tuning different class C r-f amplifiers, irrespective of the type of tube or circuit used. Although the tuning of a triode r-f amplifier is described in the following paragraphs, the procedure applies almost equally well to tetrode and pentode amplifiers. In the following explanation, it is assumed that the triode has been correctly neutralized.

The filament of the amplifier tube is lighted, the positive plate-supply lead disconnected\*\*, and r-f excitation from the driver stage applied. The plate circuit of the driver is tuned to resonance, which is indicated by a dip in the driver plate current or by maximum d-c grid current in the amplifier stage. If the amplifier has a tuned grid circuit, the latter must also be tuned to resonance (indicated by the grid-current reading). After a maximum amplifier grid current has been obtained by these tuning processes, the coupling between the driver and the amplifier may be adjusted to give still more amplifier grid current, if this can

\* See reference No. 7 in the READING LIST.

\*\* The screen voltage should also be removed, if the tube is a tetrode or a pentode.

be done without overloading the driver stage. The plate circuit of the driver should be retuned to resonance every time the coupling is changed, because of the interaction between the various circuits.

After the interstage-coupling adjustments have been made, the amplifier plate tank should be set as near to resonance as possible. A protective resistance of adequate size should then be placed in series with the positive plate-supply lead, as explained in TRANSMITTING-TUBE INSTALLATION. In the case of large, high-power tubes which are protected by d-c overload relays, this protective resistor can be omitted, especially in those installations where the d-c plate voltage can be reduced to about 50 per cent of its rated value by means of taps in the primary circuit of the plate-supply transformer. The plate voltage is now applied and the plate tank circuit quickly tuned to resonance (indicated by a sharp dip in the d-c plate current of the amplifier). The plate current at resonance will usually drop to a value between 10 and 20 per cent of the rated full-load value (see Fig. 13), if no load is coupled to the plate circuit. In case the plate

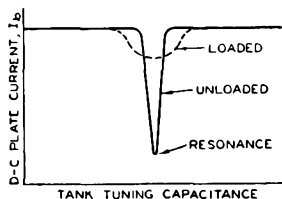

Fig. 13

tank condenser does not have an adequate voltage rating, the high r-f voltage developed across the unloaded plate tank circuit may cause the condenser to flash over. This effect should not occur with the d-c plate voltage reduced 50 per cent, if the condenser is suitable for the purpose. If it does occur, however, the load circuit can be coupled to the plate tank in order to reduce the r-f voltage developed.

If the plate tank cannot be tuned to resonance, the reason will usually be found in improper tuned-circuit constants. Either the tank inductance  $L$ , or the tank capacitance  $C$ , or both, may have to be increased or reduced, depending on whether the circuit is found to tune higher or lower than the desired frequency. An absorption-type wavemeter is useful in checking trouble of this kind. The "off-resonance" plate current of an amplifier may be quite high, even with a protective resistor in the plate supply lead. For this reason, a tube should not be operated with its plate circuit out of resonance, except for the very short time required to make the proper tuning adjustment. If the plate current does not dip normally with no load coupled to the plate tank, the trouble may be due to insufficient r-f grid excitation, to excessive tank-circuit losses, or to improper neutralization. Because the minimum plate current under no-load conditions depends on the  $Q$  of the tank circuit, on the biasing method used, and on the excitation voltage, the minimum plate-current value should not be considered a definite indication of the efficiency of an amplifier.

When the tuning procedure described has been completed, the load circuit may be coupled to the amplifier. The load may be an antenna, a dummy antenna (for test purposes), or the grid circuit of a following r-f amplifier stage. When the load is applied, the amplifier plate current will rise. The plate circuit of the amplifier should be retuned to resonance to guard against the possibility that the load has caused detuning. The plate current will still dip, but its minimum value will be considerably higher than under no-load conditions. Full plate voltage should now be applied and the coupling of the load made tighter, until the minimum plate current (at the dip) reaches the normal value given in the typical operating conditions tabulated under the tube type. Of course, if the required power output can be obtained with a lower value of plate current, the load-circuit coupling can be loosened or the d-c plate voltage reduced. In no case should

the d-c plate input exceed the value given under MAXIMUM RATINGS for the particular class of service involved.

Pentodes and tetrodes are tuned in the same manner as triodes. Because neutralization is ordinarily not required for screen-grid tubes, the circuits of these tubes are relatively simple and easy to adjust. It is quite important in a screen-grid r-f amplifier to prevent stray coupling between the input and output circuits. Although the use of a screen grid in a tube substantially eliminates internal feedback within the tube, self-oscillation and unstable operation may be caused by external feedback due to stray capacitances. Complete shielding of the input and output circuits from each other, and in some cases from the tube itself, is generally advisable.

The value of the d-c potential on the screen usually has an important effect on power output; adjustment of this voltage after the circuit has been tuned may result in better efficiency and more power output. Care should be observed, however, that the maximum rated d-c power input to the screen is not exceeded.

As the load on an r-f amplifier is increased, the d-c grid current will decrease, more so for triodes than for tetrodes and pentodes. After the load has been adjusted to the desired value, the d-c grid current should be checked. If it has dropped substantially lower than the normal value, insufficient r-f grid excitation or excessive d-c grid bias may be the cause.

The process of tuning other types of amplifiers will vary somewhat, depending on the class of service in which the tube is used.

### PARASITIC OSCILLATIONS\*

A parasitic, as the term is used in radio work, is any spurious oscillation taking place in a vacuum-tube circuit other than the normal oscillation for which the circuit is designed. Parasitic oscillations may occur in either audio- or radio-frequency amplifiers.

Parasitics, like normal oscillations, are generated when the conditions necessary for oscillations exist and may be of either audio or radio frequency. In many cases, circuit troubles which may be attributed to other causes are actually due to parasitics. They may cause the radiation of spurious carriers and side bands, voltage flashover, loss of efficiency, instability, and premature failure of vacuum tubes and other circuit elements.

Unfortunately, parasitic oscillations cannot always be foreseen and eliminated in the design of a new type of radio transmitter. It is usually necessary to remove any existing parasitics after a transmitter has been constructed. The location of the parasitic circuit often requires considerable study and may involve the use of "cut-and-try" methods. Detuning and damping of the offending circuit to stop the oscillation are often quite simple, once the undesired oscillating circuit has been located. The occurrence of parasitics during the development of a complex, modern transmitter, especially one of high power using several tubes in push-pull or in parallel, is not necessarily indicative of poor design. Such an occurrence is often to be expected.

The most detrimental parasitics are probably those which cause flashovers, spurious radiations, and low amplifier efficiency. The tubes and associated circuits in a transmitter may have damped or undamped parasitics, depending on the feedback coupling, the circuit losses, and the grid and plate potentials, as well as on the reactance and tuning of the parasitic circuit. Damped oscillations, or "trigger" parasitics, occur as the result of modulation transients, keying transients,

\*Part of the material in this section is adapted from reference No. 2 in the READING LIST.

or flashovers in vacuum tubes due to peak voltage effects. These parasitics may exist only during a part of the modulation cycle, when the plate or grid voltage is at a high positive value. When one parasitic is eliminated, it is quite possible that an entirely different one may start. Vacuum tubes can oscillate simultaneously on more than one frequency, but one oscillation may prevent one or more other oscillations from starting.

The tuned-plate-tuned-grid oscillator circuit has been found to be the basic circuit for the most common forms of parasitic oscillations. To satisfy the conditions for oscillation, there must be a grid circuit and a plate circuit tuned approximately to the same frequency together with capacitive feedback through the grid-plate capacitance of the tube. Oscillation can usually be stopped by heavy damping or by detuning of the circuits. It is generally preferable to detune a grid parasitic circuit to a much higher frequency than the corresponding plate parasitic circuit in order to stop the spurious oscillation.

Ultra-high-frequency parasitics may be generated if the leads from the amplifier tube to the plate tank condenser are long. This type of oscillation can be eliminated in a number of ways. Resistors in the order of 10 to 50 ohms may be inserted in the grid lead, plate lead, or both, close to the socket terminal. The resistors should be of the non-inductive, wire-wound type, or preferably, of the carbon-stick type. When large tubes are employed, especially in class B r-f service, it is not desirable to add very much series resistance in the grid circuit. Too much resistance tends to limit the positive modulation peaks, due to the flow of grid current through the grid resistor. A suitable method is the use of a grid resistor shunted by a low-resistance r-f choke; the latter carries the d-c grid current.

Ultra-high-frequency parasitics can also be eliminated by tuning a grid parasitic circuit to a much higher frequency than the corresponding plate parasitic circuit. This detuning can be accomplished by mounting the grid tank capacitor close to the tube in order to make the grid-to-filament circuit as short as possible. Small r-f chokes placed in series with the plate lead, next to the socket, are often helpful. In some cases, resistors should be shunted across the chokes.

Spurious oscillations are sometimes caused if the leads to the neutralizing capacitor are long. At high frequencies, long leads may have considerable inductance. A non-inductive resistor of low value placed in the lead from the tube to the neutralizing capacitor may remedy trouble from this source.

It is common practice to use a split-stator capacitor with the rotor grounded, in push-pull circuits and in single-ended circuits of the balanced type. If the

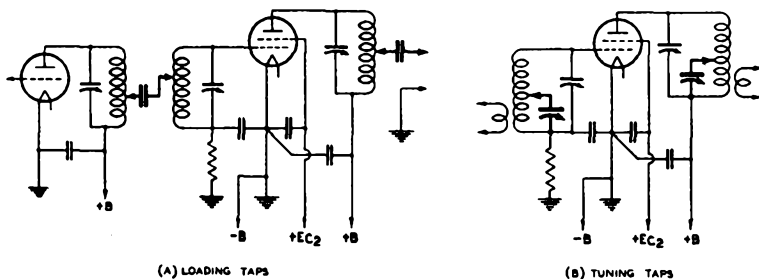

Fig. 14



capacitor is not grounded for r-f potentials, a parasitic oscillation may be the result. In such a circuit, with the rotor grounded for r-f voltages, the center tap on the tank inductance usually should not be by-passed to ground (or to the filament), because the use of a double r-f ground may unbalance the circuit and create parasitics. An r-f choke in the high-voltage lead to the plate tank inductance may prevent this condition.

When taps for loading (Fig. 14A) or tuning (Fig. 14B) are used, additional circuits for parasitics are formed. If the parasitic is caused by the use of tapped coils for loading or excitation, detuning of the coupling circuits by the addition of reactance or a change to inductive coupling may be required. The use of a tuning capacitor across a part of an inductance, as shown in Fig. 14B, creates a complex circuit which is resonant at more than one frequency. In general, this method of obtaining vernier control of tuning is undesirable, especially if the capacitor is shunted across a relatively small portion of the tank inductance.

If "shunt feed" is used for both the grid bias and the plate-voltage supply, considerable trouble may result from the complex circuits thus formed. The choke coils tend to resonate at various frequencies with the tank elements, and cause parasitics of the tuned-plate-tuned-grid variety. For this reason, it is desirable to eliminate shunt-feed chokes wherever possible. If shunt feed is used in one circuit, it is preferable to use series feed in the other. In case two chokes are used, whether in shunt-feed or in series-feed circuits, parasitics thus caused can often be eliminated by using a plate choke having about 100 times the inductance of the grid choke. This arrangement prevents the parasitic oscillating circuit from receiving sufficient excitation to continue in oscillation.

When tubes are paralleled, intertube parasitics having a very high frequency may exist. They may be eliminated by means of small resistors (in the order of 10 to 50 ohms) connected in series with each grid lead at the socket; or, the grids may be connected together with as short leads as possible and small choke coils placed in series with each plate lead.

In the checking of a transmitter for parasitics, an all-wave receiver is quite useful. The receiver will respond not only to parasitics but also to normal harmonics at integral multiples of the operating frequency. The latter are to be expected and need cause no confusion. If the receiver is a superheterodyne and is located near the transmitter, it is also important that signals due to image-frequency response not be mistaken for parasitics. An oscillating detector or a beat oscillator is a valuable aid in this method of testing. A pure tone should result from an unmodulated carrier and from its various harmonics. A rough tone usually indicates the presence of a parasitic.

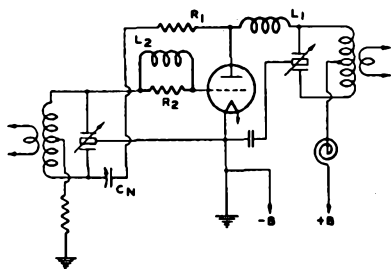

Fig. 15

Fig. 15 illustrates an r-f amplifier circuit with several circuit elements introduced to eliminate parasitic oscillations. R<sub>1</sub> and R<sub>2</sub> are non-inductive resistors having a small resistance. L<sub>1</sub> and L<sub>2</sub> are very small r-f chokes. One or more of these damping elements may be found necessary. In some cases, R<sub>2</sub> may be replaced by a variable capacitor having a very small maximum capacitance. Thus, a tuned circuit or "parasitic trap" is formed for the elimination of ultra-high-frequency parasitics.

## PROTECTIVE DEVICES

RCA transmitting tubes are designed to give long, reliable, and trouble-free service when they are operated within their maximum ratings in properly designed equipment. Even in a well-designed transmitter, however, a tube can be subjected to an overload which may be destructive if allowed to persist. Such an overload may be caused by the failure of a driver stage. In this event, the following amplifier tube will, if biased by means of a grid leak, lose its grid bias; unless the tube has a fairly high  $\mu$ , it will then draw excessive plate current. The tube must dissipate the entire d-c plate input because, with no excitation present, the plate efficiency of the tube is zero. Unless the overload is promptly removed, the tube will be damaged.

Although fixed bias from a rectifier may be employed for an r-f amplifier tube, the bias can still be lost because of rectifier trouble. Even if the grid bias and the grid excitation do not fail, an overload may result from inadvertent detuning of the plate tank from resonance. Such detuning causes a large increase in plate current and a rapid decrease in efficiency.

In view of these considerations, it is evident that radio transmitters should be equipped with suitable protective devices. D-c meters in the various circuits, while invaluable for tuning and testing purposes, as well as for power calculations, offer little assistance in preventing damage due to sudden overloads. A meter will show when the overload exists, but valuable apparatus may be destroyed before the operator can open the power-supply switch.

Protective devices, in order to be effective, must operate very rapidly when an overload occurs, so that the power input to the tube is either greatly reduced or entirely removed. Four commonly used protective devices are: (1) plate-supply series resistor; (2) cathode resistor; (3) high-voltage fuse; and (4) d-c overload relay.

A series resistor placed in the positive plate-supply lead is useful as a protective device when an amplifier stage is being adjusted initially, or when circuit changes and tests are being made. A sudden rise in plate current will increase the voltage drop across the resistor and automatically decrease the effective plate voltage. Data for calculating resistor values are given in TRANSMITTING-TUBE INSTALLATION. A series resistor in the plate circuit wastes power, and, therefore, is ordinarily not used in normal transmitter operation.

A cathode resistor, used to furnish part or all of the required d-c grid bias, acts to protect a tube against heavy overloads. The method of calculating the correct value for a cathode-bias resistor is explained under GRID-BIAS CONSIDERATIONS. The proper value for normal operating conditions may not be adequate to prevent exceeding the maximum rated plate dissipation of a tube when the grid excitation fails; however, the severity of the overload will be greatly reduced.

High-voltage fuses of the proper rating, placed in the positive plate-supply lead, protect vacuum-tube circuits very effectively. In the case of a screen-grid tube where the screen voltage is obtained from the plate supply by means of series resistor, the fuse is placed in the common positive lead so that its opening will remove both the screen voltage and the plate voltage; otherwise, with voltage on the screen only, the screen may draw excessive current.

High-voltage fuses are generally designed to blow at a current about 50 per cent higher than their rated value. Fuses designed for small currents are usually intended to carry continuously somewhat less than their rated current. For example, a typical fuse rated at 0.25 ampere has a maximum d-c load rating of 200 milliamperes for continuous operation.

The continuous-duty current rating of the high-voltage fuse employed in an amplifier stage should be about equal to the normal d-c plate current of the tube

being protected. Thus, when the d-c plate current reaches a value about 50 per cent greater than the rated value for the tube, the fuse should blow promptly.

Where a fuse is used as a protective device in a low-power stage which is followed by other stages employing grid-leak bias, it is not usually desirable to use fuses in these other stages. It is apparent that opening of the first fuse may cause fuses in the following stages to blow, due to the removal of grid excitation from all tubes following the low-power stage. If the tubes in the higher-power stages have a fairly high  $\mu$ , or employ a fixed bias sufficient to reduce the plate current to a low value when grid excitation fails, fuses can be used satisfactorily. Otherwise, a d-c overload relay is preferable.

A d-c overload relay, although initially more costly than a fuse, is one of the most satisfactory protective devices. Operating on the magnetic principle, such a relay can usually be adjusted to function on a predetermined value of d-c current. In addition, a relay can be used almost indefinitely, because it can be reset after each opening. The contactors are about the only parts subject to appreciable wear, and they can usually be replaced.

A relay is seldom used directly to open a high-voltage d-c circuit. Instead, the holding coil of the relay is placed in the negative plate-supply lead and the contactors are used to open the primary circuit of the high-voltage transformer. In some cases, it may be desirable to place the holding coil in the filament-to-ground return lead, although the coil then carries both the d-c grid current and the d-c plate current. When the holding coil is placed in either of the two positions mentioned, the coil should be shunted by a resistor having about 20 times the resistance of the relay winding. This arrangement serves to maintain the ground connection in the event that the relay winding should develop an open circuit. The relay contactors must be heavy enough to carry the relatively large a-c current flowing in the primary of the plate-supply transformer. Examples of circuits employing d-c overload relays are included in the CIRCUIT SECTION.

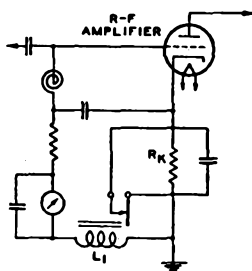

Fig. 16

Fig. 16 shows a very effective method of using a small d-c relay in conjunction with a cathode resistor to protect a grid-leak-biased tube against grid-excitation failure\*. The holding coil of the relay, inserted in the grid-return circuit, causes the relay contactors to short circuit the cathode resistor  $R_k$  as long as normal d-c grid current flows; thus, the development of bias voltage across  $R_k$  is prevented. When the grid excitation fails, however, the relay contactors open and  $R_k$  adds enough cathode bias to the circuit so that the plate current drops to a small value. The resistance value of  $R_k$  is not critical. It should be about five or more times that of the resistor which would normally be used for cathode bias. A resistance of 10,000 to 25,000 ohms is suitable for most tubes. The wattage rating of  $R_k$  depends on the d-c plate current which will flow against the bias voltage developed across  $R_k$ . This type of protective device does not guard against d-c plate-current overloads caused by plate-circuit detuning and is, therefore, not as universally effective as a d-c overload relay.

Some radio amateurs may feel that the use of protective devices for vacuum-tube circuits is not necessary for home-built transmitters. It should be remembered, however, that a fuse or a d-c overload relay will not only protect the amplifier tubes but may prevent the destruction of meters, power transformers, rectifier tubes, and other circuit elements. One heavy overload removed in time may represent a saving many times the cost of a good protective device.

\* D. A. Griffin, "Automatic Protection with Grid-Leak Bias", QST, October, 1935.

# USEFUL FORMULAS

Capacitances in parallel:

$$C = c_1 + c_2 + c_3 + \dots + c_n$$

Capacitances in series:

$$C = \frac{1}{\frac{1}{c_1} + \frac{1}{c_2} + \frac{1}{c_3} + \dots + \frac{1}{c_n}}$$

Resistances in parallel:

$$R = \frac{1}{\frac{1}{r_1} + \frac{1}{r_2} + \frac{1}{r_3} + \dots + \frac{1}{r_n}}$$

Resistances in series:

$$R = r_1 + r_2 + r_3 + \dots + r_n$$

Ohm's law (in d-c circuits):

$$I = \frac{E}{R}, \quad R = \frac{E}{I}, \quad E = RI$$

where I is in amperes

E is in volts

R is in ohms

Power (in d-c circuits):

$$P = EI = I^2R = \frac{E^2}{R}$$

where I is in amperes

E is in volts

R is in ohms

P is in watts

Sine-wave relations:

$$E_{\text{effective}} = E_{\text{rms}} = 0.707 E_{\text{max.}}$$

$$E_{\text{max.}} = 1.414 E_{\text{rms}}$$

Wavelength:

$$\lambda = \frac{300000}{f} \text{ (approx.)}$$

where  $\lambda$  is in meters

f is in kilocycles

per second (kc)

Capacitive reactance:

$$X_c = \frac{1000000}{2\pi f C} = \frac{159160}{f C}$$

where  $X_c$  is in ohms

f is in cycles per second

C is in microfarads ( $\mu\text{f}$ )

Inductive reactance:

$$X_L = 2\pi f L$$

where  $X_L$  is in ohms

f is in cycles per second

L is in henrys

Parallel-resonance relations:

$$f = \frac{159160}{\sqrt{LC}}$$

$$L = \frac{25.33 \times 10^9}{f^2 C}$$

$$C = \frac{25.33 \times 10^9}{f^2 L}$$

where f = frequency in kilo- cycles/second (kc)

L = inductance in micro- henrys ( $\mu\text{h}$ )

C = capacitance in micro- microfarads ( $\mu\mu\text{f}$ )

Transformer ratios:

$$\frac{N_s}{N_p} = \sqrt{\frac{Z_s}{Z_p}} \quad \text{or}$$

$$\frac{Z_s}{Z_p} = \frac{N_s^2}{N_p^2}$$

where  $N_s$  = secondary turns

$N_p$  = primary turns

$Z_s$  = secondary imped-  
ance, ohms

$Z_p$  = primary imped-  
ance, ohms

# RCA TRANSMITTING TUBE CHARTS

These charts will assist the tube user in making selection of a tube type for a particular service or application. The tube types have been grouped under the following headings: CLASS B MODULATORS, CLASS C AMPLIFIERS — TRIODES,

CLASS C AMPLIFIERS—TETRODES AND PENTODES, CLASS A AMPLIFIERS, and RECTIFIERS. Those types of special interest to radio amateurs have their type number shown in bold face.

## CLASS B MODULATORS

TYPE	FILAMENT		PLATE VOLTAGE Volts	GRIDS VOLTAGE Amper. Volts	PEAK A-F GRID-TO-GRID VOLTAGE Volts	PLATE CURRENT Milliamperes		PLATE-TO-PLATE LOAD RESISTANCE Ohms	DRIVER STAGE 1,2	MAX.-SIGNAL POWER OUTPUT Watts 1,3
	Volts	Ampere				Zero-Signal 1	Max.-Signal 1,2			
203-A	10	3.25	1000	-35	310	26	320	6900	Note 6	200
			1250 <sup>f</sup>	-45	330	26	320	9000		260
204-A	11	3.85	2000	-60	500	80	500	8800	Note 8	600
			3000 <sup>f</sup>	-100	500	80	372	20000		700
211	10	3.25	1000	-77	380	20	320	6900	Note 7	200
			1250 <sup>f</sup>	-100	410	20	320	9000		260
800	7.5	3.25	1000	-55	300	28	160	12500	Note 5	100
			1250 <sup>f</sup>	-70	300	30	130	21000		106
801	7.5	1.25	500	-60	290	8	130	8000	Note 6	36
			600 <sup>f</sup>	-75	320	8	130	10000		45
805	10	3.25	1250	0	235	148	400	6700	Note 6	300
			1500 <sup>f</sup>	-16	280	84	400	8200		370
806	5	10	2000	-150	680	20	390	11500	Note 8	500
			3000 <sup>f</sup>	-240	810	20	330	21500	Note 9	660
808	7.5	4	1250	-15	240	40	230	12700	Note 6	190
			1500 <sup>f</sup>	-25	220	30	190	18300		185

809	6.3	2.5	500	0	135	40	200	5200	Note 5	60
			750 <sup>†</sup>	-5	140	35	200	8400		100
830-B	10	2	800	-27	250	20	280	6000	Note 6	135
			1000 <sup>†</sup>	-35	270	20	280	7600		175
833	10	10	2500	-57	380	100	800	7300	Note 8	1425
			3000 <sup>†</sup>	-70	400	100	750	9500		1650
838	10	3.25	1000	0	200	106	320	6900	Note 6	200
			1250 <sup>†</sup>	0	200	148	320	9000		260
841	7.5	1.25	350	-5	176	7	114	5200	Note 5	21
			425 <sup>†</sup>	-5	180	13	120	7000		28
849	11	5	2000	-105	450	14	650	6400	Note 10	900
			3000 <sup>†</sup>	-155	500	24	520	12800		1100
851	11	15.5	2000	-85	500	120	1700	2600	Note 11	2200
			3000 <sup>†</sup>	-135	490	110	1200	5600		2400
852	10	3.25	2000	-155	600	22	180	22000	Note 8	220
			3000 <sup>†</sup>	-250	780	14	160	41000		320
1602	7.5	1.25	350	-40	240	8	110	6000	Note 6	20
			425 <sup>†</sup>	-50	260	8	110	8000		25
1608	2.5	2.5	350	-10	120	30	190	3800	Note 4	38
			425 <sup>†</sup>	-15	130	36	190	4800		50

† Maximum.

‡‡ For a-c filament operation.

1 Values are for two tubes.

2 For sinusoidal signals; for speech signals, the maximum-signal current values vary widely and may be as low as 50% of the values shown.

3 Values do not include output transformer losses.

4 Two 45's in push-pull, class A; plate volts=275, grid-bias volts=-56.

5 Two 2A3's in push-pull, class A; plate volts=250, grid-bias volts=-45.

6 Two 2A3's in push-pull, class AB<sub>1</sub>; plate volts=300, grid-bias volts=-62 (fixed).

7 Four 2A3's in push-pull-parallel, class AB<sub>1</sub>; plate volts=300, grid-bias volts=-62 (fixed).

8 Two 845's in push-pull, class A; plate volts=1000, grid-bias volts=-155.

9 Two 845's in push-pull, class A; plate volts=1250, grid-bias volts=-209.

10 Four 845's in push-pull-parallel, class A; plate volts=1250, grid-bias volts=-209.

11 Six 845's in push-pull-parallel, class A; plate volts=1250, grid-bias volts=-209.

12 Properly designed input transformers having adequate peak-power efficiencies should be used. Suitable transformers are commercially available.

## CLASS C AMPLIFIERS — TRIODES

TYPE	FILAMENT OR HEATER*		MAX. FREQUENCY FOR FULL INPUT Megacycles	DIRECT INTERELECTRODE CAPACITANCES $\mu\text{mf}$			AMPLIFICATION FACTOR	SERVICE P=Telephony* T=Telegraphy	MAXIMUM RATINGS			TYPICAL OPERATING CONDITIONS				
				$C_{gp}$	$C_{gr}$	$C_{pr}$			PLATE VOLT-AGE	D-C PLATE INPUT	PLATE DISSIPATION	PLATE VOLT-AGE	GRID VOLT-AGE	PLATE CURRENT	GRID DRIVING POWER	CARRIER POWER OUTPUT
	Volts	Amps		Volts	Watts	Watts			Volts	Approx. Volts	Ma.	Approx. Watts	Approx. Watts			
203-A	10	3.25	15	14.5	6.5	5.5	25	P	1000	175	67	1000	-135	150	14	100
								T	1250	220	100	1250	-125	150	7	130
204-A	11	3.85	3	15	12.5	2.3	23	P	2000	550	167	2000	-250	250	20	350
								T	2500	690	250	2500	-200	250	15	450
211	10	3.25	15	14.5	6	5.5	12	P	1000	175	67	1000	-260	150	14	100
								T	1250	220	100	1250	-225	150	7	130
800	7.5	3.25	60	2.5	2.75	2.75	15	P	1000	80	23	1000	-200	70	4	50
								T	1250	100	35	1250	-175	70	4	65
801	7.5	1.25	60	6	4.5	1.5	8	P	500	30	13.5	500	-190	55	4.5	18
								T	600	42	20	600	-150	65	4	25
805	10	3.25	30	6.5	8.5	10.5	variable high- $\mu$	P	1250	220	85	1250	-160	160	16	140
								T	1500	315	125	1500	-105	200	8.5	215
806	5	10	30	3.4	6.1	1.1	12.6	P	2500	500	110	2500	-600	195	32	390
								T	3000	600	150	3000	-600	195	20	450
808	7.5	4	30	2.8	5.3	0.15	47	P	1250	135	35	1250	-225	100	10.5	105
								T	1500	200	50	1500	-200	125	9.5	140

809	6.3	2.5	60	6.7	5.7	0.9	50	P	600	50	17.5	600	-160	83	7.2	38
								T	750	75	25	750	-60	100	2.5	55
830-B	10	2	15	11	5	1.8	25	P	800	80	40	800	-150	95	5	50
								T	1000	150	60	1000	-110	140	7	90
831	11	10	20	4	3.8	1.4	14.5	P	3000	650	270	3000	-500	200	50	360
								T	3500	1200	400	3500	-400	275	30	590
833	10	10	30	6.3	12.3	8.5	35	P	2500	835	200	2500	-300	335	30	635
								T	3000	1250	300	3000	-200	415	20	1000
834	7.5	3.25	100	2.6	2.2	0.6	10.5	P	1000	100	35	1000	-310	90	6.5	58
								T	1250	125	50	1250	-225	90	4.5	75
838	10	3.25	30	8	6.5	5	variable high-mu	P	1000	175	67	1000	-135	150	16	100
								T	1250	220	100	1250	-90	150	6	130
841	7.5	1.25	6	7	4	3	30	P	350	21	10	350	-47	50	2	11
								T	450	27	15	450	-34	50	1.8	15
843	2.5*	2.5	6	4.5	4	4	7.7	P	350	14	10	350	-150	30	1.6	5
								T	450	18	15	450	-140	30	1	7.5
849	11	5	3	33.5	17	3	19	P	2000	700	270	2000	-300	300	14	425
								T	2500	875	400	2500	-250	300	8	560
851	11	15.5	3	47	25.5	4.5	20.5	P	2000	1800	500	2000	-300	850	65	1250
								T	2500	2500	750	2500	-250	900	45	1700
852	10	3.25	30	2.6	1.9	1	12	P	2000	170	67	2000	-500	67	23	75
								T	3000	300	100	3000	-600	85	12	165
1602	7.5	1.25	6	7	4	3	8	P	350	17.5	10	350	-135	45	3.5	8
								T	450	27	15	450	-115	55	3.3	13
1608	2.5	2.5	45	9	8.5	3	20	P	350	30	13.5	350	-80	85	3	18
								T	425	40	20	425	-90	95	3	27

\* Indicates heater-cathode type.

\*\* Telegraphy values are for plate-modulated conditions.



## CLASS C AMPLIFIERS — TETRODES AND PENTODES

TYPE	FILAMENT OR HEATER*		MAX. FREQUENCY FOR FULL INPUT Megacycles	DIRECT INTERELECTRODE CAPACITANCES pF			SERVICE P=Telephony** T=Telegraphy	MAXIMUM RATINGS			TYPICAL OPERATING CONDITIONS						
	Volts	Amperes		C <sub>sp</sub>	C <sub>input</sub>	C <sub>output</sub>		PLATE VOLT-AGE Volts	D-C PLATE INPUT Watts	PLATE DISSIPATION Watts	PLATE VOLT-AGE Volts	SUPPRESSOR VOLTAGE Volts	SCREEN VOLT-AGE Volts	GRID VOLT-AGE Approx. Volts	PLATE CURRENT Ma.	GRID DRIVING POWER Approx. Watts	CARRIER POWER OUTPUT Approx. Watts
802 <sup>†</sup>	6.3*	0.9	30	0.15	12	8.5	P	400	16	6.7	400	40	195	-40	35	0.1	8
							T	500	25	10	500	40	250	-100	45	0.25	16
803 <sup>†</sup>	10	5	20	0.15	17.5	29	P	1600	250	85	1600	100	500	-80	150	4	155
							T	2000	350	125	2000	40	500	-90	160	2	210
804 <sup>†</sup>	7.5	3	15	0.01	16	14.5	P	1000	80	27	1000	50	220	-90	75	0.65	50
							T	1250	120	40	1250	45	300	-100	92	0.95	80
807 <sup>††</sup>	6.3*	0.9	60	0.20	11	7	P	475	40	16.5	475	—	225	-50	83	0.1	24
							T	600	60	25	600	—	250	-50	100	0.22	37.5
814 <sup>††</sup>	10	3.25	30	0.1	13.5	13.5	P	1000	120	34	1000	—	300	-150	120	2	87
							T	1250	180	50	1250	—	300	-80	144	1.5	130
837 <sup>†</sup>	12.6*	0.7	20	0.2	16	10	P	400	20	8	400	40	140	-40	45	0.3	11
							T	500	32	12	500	40	200	-75	60	0.4	22
844 <sup>‡</sup>	2.5*	2.5	8	0.15	9.5	7.5	P	500	—	10	500	—	150	-100	20	—	4
							T	500	—	15	500	—	175	-125	25	—	9
850 <sup>‡</sup>	10	3.25	13	0.25	17	25	P	1000	150	70	1000	—	140	-100	125	10	65
							T	1250	220	100	1250	—	175	-150	160	10	130
860 <sup>‡</sup>	10	3.25	30	0.08	7.75	7.5	P	2000	170	67	2000	—	220	-200	85	17	105
							T	3000	300	100	3000	—	300	-150	85	7	165
861 <sup>‡</sup>	11	10	20	0.1	14.5	10.5	P	3000	650	270	3000	—	375	-200	200	35	400
							T	3500	1200	400	3500	—	500	-250	300	30	700
865 <sup>‡</sup>	7.5	2	15	0.1	8.5	8	P	500	30	10	500	—	125	-120	40	2.5	10
							T	750	45	15	750	—	125	-80	40	1	16
1610 <sup>†</sup>	2.5	1.75	20	1.2	8.6	13	T	400	9	6	400	—	150	-50	22.5	0.1	5

\* Indicates heater-cathode type

† Pentode

†† Beam Power Amplifier

‡ Tetrode

\*\* Telephony values are for plate-modulated conditions

## CLASS A AMPLIFIERS

TYPE	FILAMENT OR HEATER*		TYPICAL PLATE VOLTAGE Volts	TYPICAL POWER OUTPUT Watts
	Volts	Amperes		
<b>TRIODES</b>				
801	7.5	1.25	600	3.8
841	7.5	1.25	425	Voltage Amplifier
842	7.5	1.25	425	3
843*	2.5	2.5	425	1.6
845	10	3.25	1000	21
849	11	5	2500	81
851	11	15.5	2000	100
864	1.1	0.25	90	Voltage Amplifier
955*	6.3	0.15	180	Voltage Amplifier
1602	7.5	1.25	425	1.6
<b>PENTODES</b>				
954*	6.3	0.15	250	Voltage Amplifier
956*	6.3	0.15	250	Voltage Amplifier <sup>††</sup>
.1603	6.3	0.3	250	Voltage Amplifier
1609	1.1	0.25	135	Voltage Amplifier

\* Indicates heater-cathode type.

†† Super-control type.

## RECTIFIERS

TYPE	FILAMENT OR HEATER*		MAXIMUM RATINGS			
	Volts	Amperes	AVERAGE PLATE CURRENT Amperes	PEAK PLATE CURRENT Amperes	PEAK INVERSE VOLTAGE Volts **	CONDENSED MERCURY TEMP. RANGE °C
<b>HALF-WAVE MERCURY-VAPOR</b>						
866	2.5	5	0.25	1.0	7500	0-60
866-A	2.5	5	0.25	1.0	5000	25-70
					10000	25-60
871	2.5	2	0.125	0.5	5000	10-60
872	5	10	1.25	5.0	7500	10-60
872-A	5	6.75	1.25	5.0	5000	20-70
					10000	20-60
<b>HALF-WAVE HIGH-VACUUM</b>						
217-A	10	3.25	0.20	0.6	3500	—
217-C	10	3.25	0.15	0.6	7500	—
836*	2.5	5	0.25	1.0	5000	—

\* Indicates heater-cathode type.

\*\* Where two ratings are given for any type, better temperature control is required for the higher rating, as indicated.

# Rectifiers and Filters

## RECTIFIER TUBES

Rectifier tubes are of the diode type. Their operation is discussed under the section **GENERIC TUBE TYPES**. The installation requirements of rectifier tubes are, in general, similar to those of other transmitting tubes and are covered under **TRANSMITTING TUBE INSTALLATION**. Special installation considerations peculiar to rectifier tubes follow.

During its **initial operation**, a mercury-vapor rectifier tube should be operated with normal filament voltage and no plate voltage in order to distribute the mercury properly. The time required for this slow-treating schedule is given under the **CHARACTERISTICS** for each mercury-vapor tube type. It is unnecessary to repeat this procedure unless during subsequent handling, the mercury is again spattered on the filament and plate.

The application of plate voltage should always be delayed until the filament has attained normal operating temperature. The **delay period** is determined by the length of time necessary to heat the filament and, in mercury-vapor tubes, the length of time necessary to raise the condensed-mercury temperature to the minimum value at which the tube will operate satisfactorily. Factors which increase the delay period are poor regulation of the filament-voltage supply and low ambient temperature. If the filament-voltage supply has good regulation and the ambient temperature is normal, the delay period will be that specified under **CHARACTERISTICS** for each rectifier tube type. If there is any evidence in the tube of improper operation, such as sputtering or arc-back, the delay period should be increased.

The **condensed-mercury temperature** of a mercury-vapor rectifier tube should be maintained within the ranges tabulated for each tube type. Low condensed-mercury temperature raises the potential at which the tube starts to conduct and is unfavorable for long filament life. High condensed-mercury temperature decreases the potential at which the tube starts to conduct and is favorable for long filament life but reduces the peak inverse voltage that the tube can stand. The temperature of the condensed mercury may be measured with a thermocouple or a small thermometer attached with a small amount of putty at a point near the base of the bulb.

The **bulbs** of mercury-vapor rectifier tubes eventually darken in service. This darkening is normal and is not an indication of the end of tube life.

**Voltage and current ratings** for rectifier tubes in this book are given on the basis of maximum peak inverse voltage, maximum peak plate current, and maximum average plate current.

**Maximum peak inverse voltage** is the highest peak voltage that a rectifier tube can safely stand in the direction opposite to that in which it is designed to pass current. In a mercury-vapor rectifier tube, it is the safe arc-back limit with the tube operating within the recommended condensed-mercury temperature range. The relation between peak inverse voltage, d-c output voltage, and RMS value of a-c input voltage depends largely on the individual characteristics of the rectifier circuit and the power supply. The presence of line surges, keying surges, any other transients, or waveform distortion may raise the actual peak voltage to a value higher than that calculated for sine-wave voltages. Therefore, the actual inverse voltage, not the calculated value, should be such as not to exceed the rated maximum peak inverse voltage for the rectifier tube. A cathode-ray oscillograph, or a spark gap connected across the tube, is useful in determining the actual peak inverse voltage. In single-phase, half-wave circuits with sine-wave input and with condenser input to the filter, the peak inverse voltage may be as high as 2.8 times the RMS value of the applied voltage. In single-phase, full-wave circuits with sine-wave input, the peak inverse voltage on a rectifier tube is approximately 1.4 times the RMS value of the transformer plate-to-plate voltage applied to the tubes. In polyphase circuits, the peak inverse voltage should be calculated for each circuit.

**Maximum peak plate current** is the highest instantaneous current that a rectifier tube can safely stand in the direction in which it is designed to pass current. The safe value of this peak current in hot-cathode types of rectifier tubes is a function

of the electron emission available and the duration of the pulsating flow from the rectifier tube during each half-cycle. In a given circuit, the value of peak plate current is largely determined by the filter constants. If a large choke is used in the filter circuit next to the rectifier tubes, the peak plate current is not much greater than the load current; if a large condenser is used in the filter next to the rectifier tubes, the peak current is often many times the load current. In order to determine accurately the peak current in any circuit, the best procedure usually is to measure it with a peak-indicating meter or to use an oscillograph.

**Maximum average plate current** is the highest value of average current that should be allowed to flow through the tube. With a steady load, this current may be read directly on a d-c meter. With a fluctuating load, the reading should be averaged over the period of time specified under CHARACTERISTICS for each rectifier tube.

A suitable fuse or an overload relay should be placed in the primary circuit of the power transformer for protection of the power supply against accidental overload.

Rectifier tubes, especially those of the mercury-vapor type, should be isolated from the transmitter as much as possible in order to avoid the detrimental effects of electromagnetic and electrostatic fields. These tend to produce breakdown effects in mercury vapor, are detrimental to tube life, and make filtering difficult. External shielding should be used when the tubes are in proximity to these external fields. R-f filtering should be used when the tubes are affected by r-f voltages. See Fig. 17. When shields are used, special attention must be given to adequate ventilation and to the maintenance of normal condensed-mercury temperature.

Mercury-vapor rectifier tubes occasionally produce a form of local interference in audio and modulator stages of transmitters and in radio receivers, through direct radiation or through the power line. This interference is generally identified in the receiver as a broadly tunable 120-cycle buzz (100 cycles for 50-cycle supply line, etc.). It is usually caused by the formation of a steep wave front when plate current within the tube begins to flow on the positive half of each cycle of the

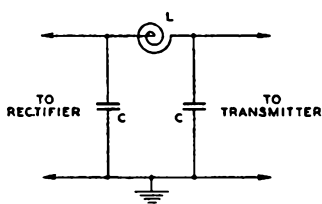

C = R-F BY-PASS CONDENSER, MICA  
L = R-F CHOKE

Fig. 17

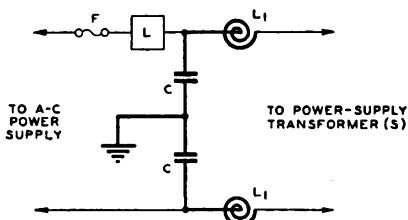

C = R-F BY-PASS CONDENSER, MICA  
F = FUSE  
L = OVERLOAD RELAY  
L<sub>1</sub> = R-F CHOKE, LOW RESISTANCE

Fig. 18

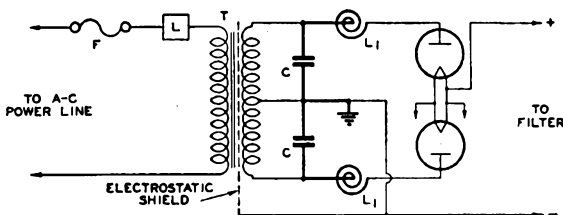

C = R-F BY-PASS CONDENSER, MICA  
F = FUSE  
L = OVERLOAD RELAY  
L<sub>1</sub> = R-F CHOKE  
T = POWER-SUPPLY TRANSFORMER

Fig. 19

a-c supply voltage. There are a number of effective methods for eliminating this type of interference. One is to introduce an r-f line filter in the primary circuit of the power-supply transformer. See Fig. 18. Another is to insert an r-f choke between each plate and transformer winding and to connect high-voltage, r-f by-pass condensers between the outside ends of the transformer winding and the center tap. See Fig. 19. These condensers should have a voltage rating high enough to withstand the peak voltage of each half of the secondary, which is approximately 1.4 times the RMS value. Transformers having electrostatic shielding between primary and secondary are not likely to transmit r-f disturbances to the line. Often the interference may be eliminated simply by making the plate leads of the rectifier extremely short. In general, the particular method of interference elimination must be selected by experiment for each installation.

## RECTIFIER CIRCUITS

Rectifier circuits are shown in Figs. 20 to 24. Fig. 20 shows the widely used, single-phase, full-wave rectifier using two half-wave rectifier tubes. Fig. 21 shows a single-phase bridge circuit employing two half-wave rectifier tubes in series on each side of a single-phase transformer secondary. This circuit is capable of giving twice the d-c output voltage for the same total transformer voltage and d-c output current as Fig. 20. Since the total peak secondary voltage is also the same as that for Fig. 20, tubes of the same peak inverse voltage rating can be used. When the bridge circuit is used, it may be necessary to reduce the load current in order to avoid exceeding the power rating of the high-voltage transformer. Fig. 22 shows a three-phase, half-wave circuit using three half-wave rectifier tubes. In this circuit, each tube conducts for only one-third cycle and three-phase waveform is obtained. Fig. 23 shows a three-phase, double-Y parallel circuit employing six half-wave rectifier tubes. In this circuit, an interphase reactor is required but only one filament-voltage supply is necessary. Fig. 24 shows a three-phase, full-wave bridge circuit employing six half-wave rectifier tubes. Two tubes are connected in series with each transformer leg. Like the bridge circuit of Fig. 21, this circuit will give twice the d-c output voltage of the half-wave circuit in Fig. 22. In the three-phase full-wave and three-phase double-Y parallel circuits, six-phase waveform is obtained. This requires relatively little filtering. A summary of the approximate conditions which can be obtained with the use of any mercury-vapor rectifier tube in these circuits is shown in the tabulation. The table is based on sine-wave input and the use of a suitable choke preceding any condenser in the filter circuit (see FILTERS). The table does not take into account the voltage drop in the power transformer, the rectifier tubes, nor the filter-choke windings, under load conditions.

### EXAMPLE OF USE OF TABLE

**Problem:** Choose a type of rectifier tube suitable for use in a single-phase, full-wave power supply to deliver a total average current of 500 milliamperes at a maximum d-c voltage of 2385 volts. Also, for what maximum secondary voltage ( $E_{RMS}$ ) should the transformer be designed in order to deliver 2385 volts to the filter at maximum load current.

**Procedure:** First, determine the maximum peak inverse voltage which each rectifier tube must withstand. By reference to the relations shown for the single-phase, full-wave circuit (Fig. 20 in the above table), it is found that the maximum peak inverse voltage corresponding to a d-c voltage of 2385 volts is  $3.14 \times 2385$ , or 7489 volts. Since two half-wave rectifiers will be required in this service, each rectifier will only have to deliver 500/2, or 250 milliamperes. A rectifier tube meeting these voltage and current requirements is the RCA-866, with a peak inverse voltage rating of 7500 volts and an average plate current rating of 250 milliamperes. In order to deliver 2385 volts to the filter at maximum load, the transformer should be designed so that each half of the secondary will produce an  $E_{RMS}$  of  $1.11 \times 2385$ , or 2647 volts.

The percentage change in output voltage of the power supply between no-load and full-load conditions is known as **voltage regulation**. For example, if the d-c output voltage is 1000 volts at no load and is 900 volts at full load, the voltage regulation is  $(1000-900)/1000 = 0.1$ , or 10%. Well-designed power supplies have

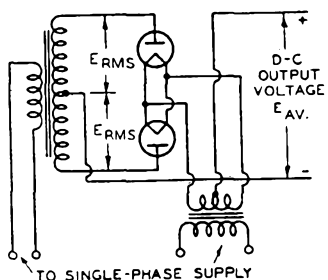

FIG. 20

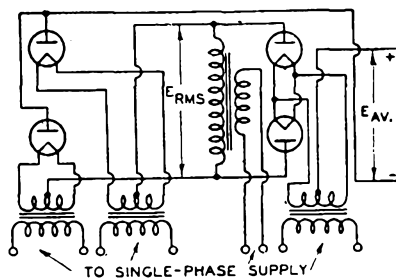

FIG. 21

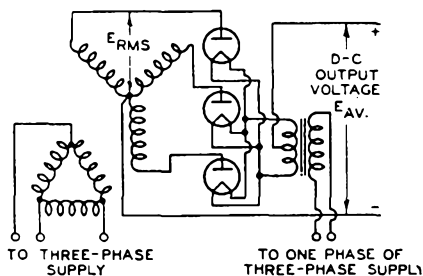

FIG. 22

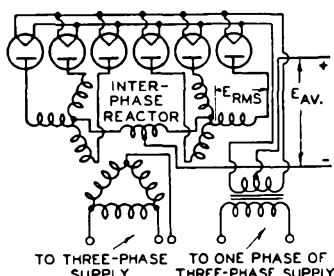

FIG. 23

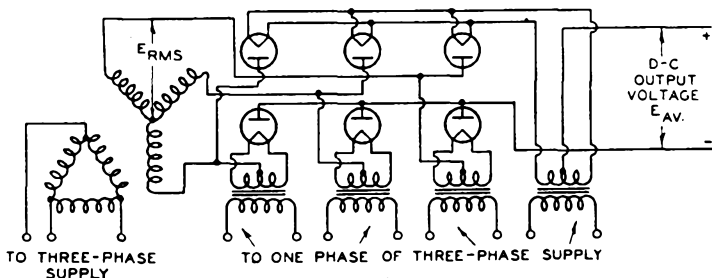

FIG. 24

CIRCUIT	SEE FIG.	TRANSFORMER SECONDARY VOLTAGE $E_{RMS}$	D-C OUTPUT VOLTAGE TO FILTER $E_{AV}$	PEAK INVERSE VOLTAGE $E_{INV}$	MAX. AVERAGE LOAD CURRENT PERMITTED
Single-Phase Full-Wave (2 Tubes)	20	(per tube) $0.353 \times E_{INV}$ . or $1.11 \times E_{AV}$ .	$0.318 \times E_{INV}$ . or $0.9 \times E_{RMS}$	$3.14 \times E_{AV}$ or $2.83 \times E_{RMS}$	$2 \times$ { Max. Average Plate-Current Rating per Rectifier Tube
Single-Phase Full-Wave Bridge (4 Tubes)	21	(total) $0.706 \times E_{INV}$ . or $1.11 \times E_{AV}$ .	$0.636 \times E_{INV}$ . or $0.9 \times E_{RMS}$	$1.57 \times E_{AV}$ . or $1.41 \times E_{RMS}$	$2 \times$ { Max. Average Plate-Current Rating per Rectifier Tube
Three-Phase Half-Wave (3 Tubes)	22	(per leg) $0.408 \times E_{INV}$ . or $0.855 \times E_{AV}$ .	$0.478 \times E_{INV}$ . or $1.17 \times E_{RMS}$	$2.09 \times E_{AV}$ . or $2.45 \times E_{RMS}$	$3 \times$ { Max. Average Plate-Current Rating per Rectifier Tube
Three-Phase Parallel Double Y	23	(per leg) $0.408 \times E_{INV}$ . or $0.855 \times E_{AV}$ .	$0.478 \times E_{INV}$ . or $1.17 \times E_{RMS}$	$2.09 \times E_{AV}$ . or $2.45 \times E_{RMS}$	$6 \times$ { Max. Average Plate-Current Rating per Rectifier Tube
Three-Phase Full-Wave (6 Tubes)	24	(per leg) $0.408 \times E_{INV}$ . or $0.428 \times E_{AV}$	$0.956 \times E_{INV}$ . or $2.34 \times E_{RMS}$	$1.05 \times E_{AV}$ . or $2.45 \times E_{RMS}$	$3 \times$ { Max. Average Plate-Current Rating per Rectifier Tube

a regulation of 10 per cent or less. Good plate-supply regulation is essential in self-excited oscillators to maintain frequency stability; it is essential for class B a-f amplifiers and modulators where the load current varies with the average signal voltage; and it is equally essential in the keyed r-f amplifier stage where key thumps must be minimized and condenser breakdown avoided. The voltage output of a power supply is reduced by the voltage drop through the rectifier tubes (only 15 volts in mercury-vapor types), the transformer-windings, and the filter-choke windings. It is also influenced by the type of filter system. The power transformer should be of substantial size, of generous overload rating, and should have low-resistance windings. A filter choke should have the proper value of inductance for the operating conditions, and a low-resistance winding. The use of "swinging" chokes and choke-input filters helps to provide good regulation. Their use is discussed under FILTERS.

A heavy-duty bleeder resistor connected across the output terminals of the power supply assists in maintaining good voltage regulation. The resistor prevents the filter condensers from charging up to the peak value of the a-c voltage and offers protection against accidental shock from contact with charged filter condensers after the power supply has been switched off. The value of current through the bleeder is frequently made about 10 per cent of the full-load current.

Two or more mercury-vapor rectifier tubes can be connected in parallel to give correspondingly increased output current over that obtainable with a single tube. A stabilizing resistor of 50 to 100 ohms should be connected in series with each plate lead in order that each tube will carry an equal share of the load. The value of the resistor to be used will depend on the amount of plate current that passes through the rectifier. Low plate current requires a high value; high plate current, a low value. When the plates of mercury-vapor rectifier tubes are connected in parallel, the corresponding filament leads should be similarly connected. Otherwise the tube drops will be considerably unbalanced and larger stabilizing resistors will be required. When it is desirable to minimize the small power loss caused by the voltage drop through the stabilizing resistor, an inductance of approximately one-third henry may be substituted. The use of the inductance has the added advantage of helping to limit the peak current to each tube. This is especially desirable if a condenser-input type of filter is used.

Two or more high-vacuum rectifier tubes can also be connected in parallel to give corresponding higher output current and, as a result of paralleling their internal resistances, give somewhat increased voltage output. The use of stabilizing resistors is generally unnecessary with parallel-connected high-vacuum rectifiers.

## FILTERS

Filters of either the choke-input or the condenser-input type may be employed to minimize rectifier ripple voltage. With either type of filter, the maximum ratings shown under CHARACTERISTICS for each rectifier tube should not be exceeded.

A choke-input filter has the advantages of providing good voltage regulation, of limiting current surges during switching, and of limiting peak plate current during rectifier operation. This type of filter is preferable from the standpoint of obtaining the maximum continuous d-c output from a rectifier tube under the most favorable conditions. It is especially recommended for use with mercury-vapor rectifier tubes and with high-vacuum rectifier tubes having closely-spaced electrodes. The performance of a good choke-input filter can be calculated accurately.

A condenser-input filter has the advantage of increasing the voltage output from a rectifier. It has the disadvantages of causing poor voltage regulation, of causing high switching surges, and of reducing the d-c load current over that permissible when choke input is used. A large input capacitance causes a high surge current when the power switch is closed; a small input capacitance reduces the surge current but decreases the filtering action and the voltage output. When a condenser-input type of filter is used, a current-limiting resistor should be connected between the rectifier tubes and filter to reduce the tube current to a safe amount at the time of switching on the rectifier. The value of this resistance, which also includes the power transformer resistance, can be determined as follows:

Current-limiting resistance in ohms =  $\frac{k \times E_{RMS}}{\text{rated peak plate tube current in amperes}}$   
 where  $k$  is equal to 1.41 for circuits of Figs. 20 through 23, and 2.45 for Fig. 24. After the rectifier-filter system has been switched on, the resistor can be short-circuited to avoid reducing the d-c output voltage. The resistor is employed at each switching operation. Because of the many variable factors involved in the functioning of a condenser-input filter, its performance is more difficult to determine than that of a choke-input system.

The general filter-design curves in Figs. 25A and 25B are useful in the selection of suitable combinations of chokes and condensers for choke-input filters. Values can be chosen from these curves to limit the peak plate current and the average plate current to the maximum rating of any rectifier tube for a given percentage of ripple voltage in single-phase, full-wave circuits operating from a 60-cycle supply. When the power supply is operated from a 50-cycle source, multiply the values of selected inductance and capacity by 60/50, or 1.2. When the power supply is operated from a 25-cycle source, multiply the selected filter values by 60/25, or 2.4.

The load resistance curves, identified by  $R_L$ , give the minimum or critical value of inductance that should be used with the indicated load resistance. Lower than the minimum inductance values may result in overloading of the rectifier tubes under steady operating conditions, and in poor regulation. The value of  $R_L$  for any specific design is obtained by dividing the required rectifier d-c output voltage by the desired load current (in amperes). The d-c output voltage used for this calculation is taken as 90% of the RMS voltage per rectifier tube plate. It does not take into consideration the regulation of the power transformer, filter choke(s), or rectifier tube(s). The percentage ripple curves, identified by  $E_{R1}$ , represent the percentage ripple for any single-section filter combination. An  $E_{RMS}$  line is given for each rectifier tube type. It shows the various combinations of minimum filter inductance and maximum filter capacitance ( $C_1$ ) that will limit the surge current to the maximum peak plate current rating of the particular tube it represents, at the maximum peak inverse voltage rating of the tube. Always select filter constants to the left of  $E_{RMS}$ . When lower than the rated maximum peak inverse voltage is used for a tube type, lower inductance and higher capacitance values may be used without exceeding the peak current rating of the tube. In this case, the filter combination is selected to the left of a new  $E_{RMS}$  line, the points of which are determined from the equation.

$$L_1 = \left( \frac{E_{RMS}}{I_{MAX.} \times 1110} \right)^2 C_1$$

where  $C_1$  = First filter condenser capacitance in microfarads  
 $L_1$  = First filter choke inductance in henries  
 $I_{MAX.}$  = Peak plate current rating of tube in amperes  
 $E_{RMS}$  = RMS transformer voltage per tube

When more filtering is required than can be obtained economically by means of a single filter section, a second filter section may be added to the first. The size of  $L_2$  and  $C_2$  for the second section may be easily determined from Fig. 25B. Since  $E_{R1}$  is known for the first section, the values of  $L_2$  and  $C_2$ , as a product, may be read from the appropriate  $E_{R1}$  curve for any desired value of percentage ripple  $E_{R2}$ . Practically any values of  $L_2$  and  $C_2$  forming the product read from the curve can be used for the second section. However, in order to avoid serious circuit instability and impairment of filtering due to 120-cycle resonance,  $L_2$  (in henries) must always be greater than  $3(C_1 + C_2) \div 2C_1 C_2$ , where  $C_1$  and  $C_2$  are in microfarads.

When designing a single-section filter, use Fig. 25A and observe the following rules. Always select inductance values, (1) above the proper  $R_L$  curve, (2) to the left of the proper  $E_{RMS}$  curve, and (3) along the desired  $E_{R1}$  curve. Use the corresponding value of filter capacitance for each selected value of inductance. When designing the second section of a double-section filter, use Fig. 25B and observe the following rules. (1) Select desired percentage of output ripple voltage  $E_{R2}$  on appropriate curve of  $E_{R1}$ . (2) Read corresponding  $L_2 C_2$  product. (3) To satisfy this product, choose convenient values of  $L_2$  and  $C_2$ . (4) Check the chosen value of  $L_2$  to insure that it is greater than  $3(C_1 + C_2) \div 2C_1 C_2$ .



When the load resistance varies over a wide range, good regulation may be obtained by (1) connecting a bleeder resistance across the filter output to restrict the range over which the effective load varies, (2) using an input choke with sufficient inductance to meet all values of load resistance up to the highest attained, or (3) using a swinging input choke. The last method is the more economical.

The inductance of a well-designed swinging choke rises from its normal value at rated load current to a high value at low load current. The required minimum and maximum values of swinging choke inductance can be determined from Fig. 25A at the intersection of the proper  $E_{RMS}$  curve with the minimum and maximum  $R_L$  curves, respectively. It is generally more economical to select low values of swinging choke inductance and to depend on additional filter sections to provide the required smoothing.

#### EXAMPLE No. 1

**Problem:** Given a d-c output voltage of 3180 volts (corresponds to a peak inverse voltage of 10,000 volts) from a 60-cycle full-wave rectifier employing two 872-A's, design a single-section filter of the choke-input type which will limit the ripple voltage to 5% at a load current equal to the combined maximum d-c load-current rating of the tubes (2.5 amperes), and prevent the peak plate current of either tube from rising higher than the maximum peak plate-current rating of the 872-A.

**Procedure:**  $E_{RMS}$  is equal to  $3180 \times 1.11$ , or 3535 volts.  $R_L$  is equal to  $3180/2.5$  amperes, or 1272 ohms. From Fig. 25A,  $R_L = 1272$  lies below curve  $E_{RMS} = 3535$  (as shown for the 872-A) and, therefore, is not required for the selection of filter constants. Any combination of inductance and capacitance along the curve  $E_{R1} = 5\%$  and to the left of the curve  $E_{RMS} = 3535$  will satisfy the requirements. A suitable combination is a filter section employing a 25-henry choke and a 1-microfarad condenser.

#### EXAMPLE No. 2

**Problem:** Given a d-c output voltage of 2385 volts (corresponds to a peak inverse voltage of 7500 volts) from a 60-cycle full-wave rectifier employing two type 866's, design a double-section filter which will limit the output ripple voltage to 0.5% at a load current equal to the combined maximum d-c load-current rating of the tubes (500 milliamperes) and prevent the peak plate current of either tube from rising higher than the maximum peak plate-current rating of the 866. The input choke is to be of the swinging type and the voltage regulation is to be good from no-load to full load.

**Procedure:**  $E_{RMS}$  is equal to  $2385 \times 1.11$ , or 2650 volts. At maximum load,  $R_L = 2385/0.5$  ampere, or 4770 ohms. Since curve  $R_L = 4770$  lies below curve  $E_{RMS} = 2650$  volts (as shown for the 866), it is not needed in the selection of constants for the first filter section. A value of 10% ripple at the output of the first filter section will be assumed to be satisfactory. The minimum value of swinging-choke inductance and corresponding value of capacitance for the first-section filter condenser may, therefore, be selected along curve  $E_{R1} = 10\%$  and to the left of curve  $E_{RMS} = 2650$  volts (for 866). Suitable values are 13.5 henries and 1 microfarad. The maximum value of swinging choke inductance to be used with a condenser having a capacity of 1 microfarad should be as high as practical. Assume that this value is 40 henries. Then, with a capacitance value of 1 microfarad, the maximum value of  $R_L$  is 44,000 ohms. Therefore, a bleeder resistance of 44,000 ohms is required to keep the d-c output from "soaring" at no-load conditions. With a load resistance of 44,000 ohms, the bleeder current is  $2385/44000 = 0.054$  ampere, or 54 milliamperes. The total useful d-c output current is then  $500 - 54$ , or 446 milliamperes.

The design of the second filter section should now be considered. It must be capable of reducing the ripple voltage from 10% in the first section to 0.5% in its own output. From Fig. 25B, the value of the product  $L_2 C_2$  is 37 as read on the curve  $E_{R1} = 10\%$  when  $E_{R2} = 0.5\%$ . If  $C_2$  is chosen to be 2 microfarads,  $L_2 = 37/2$ , or 18.5 henries. This value of  $L_2$  is greater than 3 ( $C_1 + C_2$ )  $\div$   $2 C_1 C_2 = 3(1 + 2) \div 2(1 \times 2)$ , or 2.25, and therefore is of ample size to avoid resonance effects.

# FILTER DESIGN CURVES

## FOR FULL-WAVE SINGLE-PHASE CIRCUITS ONLY

### 60-CYCLE SINE-WAVE SUPPLY\*

Fig. 25A—Curves for choice of filter values for (1) the first section of a double-section filter, or (2) a single-section filter.

Fig. 25B—Curves for choice of filter values for second section of a double-section filter.

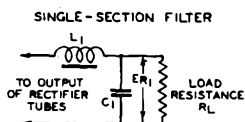
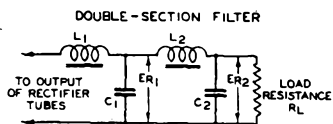
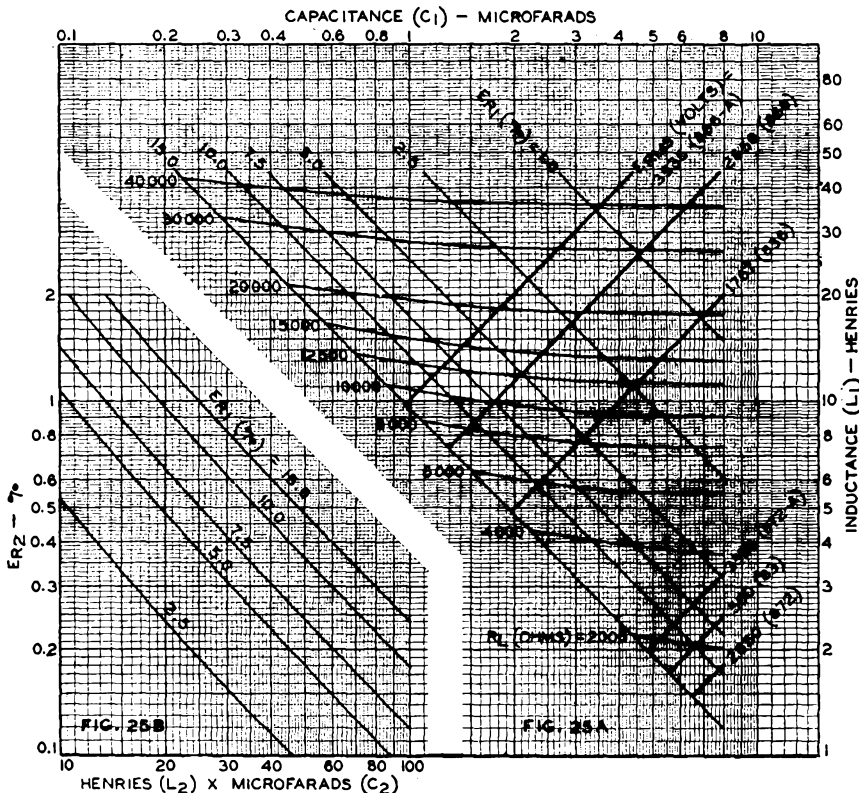

$ER_{MS}$  = MAXIMUM VOLTS (RMS) PER PLATE APPLIED TO RECTIFIER TUBE  
 $R_L$  = LOAD RESISTANCE  
 $ER_1$  = PER CENT RIPPLE IN D-C OUTPUT VOLTAGE FROM (1) THE FIRST SECTION OF A DOUBLE-SECTION FILTER, OR (2) A SINGLE-SECTION FILTER  
 $ER_2$  = PER CENT RIPPLE IN D-C OUTPUT VOLTAGE FROM SECOND SECTION OF A DOUBLE-SECTION FILTER

#### GENERAL RULES FOR SELECTION OF FILTER CONSTANTS

##### SINGLE-SECTION FILTER (FIG. 25A)

- (1) SELECT INDUCTANCE VALUES (1) ABOVE PROPER  $R_L$  CURVE
  - (2) TO LEFT OF PROPER  $ER_{MS}$  CURVE
  - (3) ALONG DESIRED  $ER_2$  CURVE
- FOR EACH SELECTED INDUCTANCE VALUE, USE CORRESPONDING VALUE OF FILTER CAPACITANCE

##### DOUBLE-SECTION FILTER (FIG. 25B)

- (1) SELECT DESIRED PERCENTAGE OF OUTPUT RIPPLE VOLTAGE  $ER_2$  ON APPROPRIATE CURVE OF  $ER_1$
- (2) READ CORRESPONDING  $L_2 C_2$  PRODUCT
- (3) TO SATISFY THIS PRODUCT, CHOOSE CONVENIENT VALUES OF  $L_2$  AND  $C_2$
- (4) CHECK VALUE OF SELECTED  $L_2$  TO MAKE SURE THAT IT IS GREATER THAN  $3(C_1 + C_2) + 2C_1 C_2$

\* See text for applying these curves to other supply frequencies.

# CIRCUIT SECTION

The schematic diagrams given on the following pages have been carefully chosen to illustrate the use of different generic tube types in diversified transmitting applications. All of the circuits are designed to give reliable and satisfactory performance; they show, for the most part, simple, conventional, straight-forward arrangements which experience has shown to be dependable. Although relatively few circuits are given, it is often practical to use a portion of one circuit in combination with portions of other circuits to obtain a design meeting the desired requirements. In general, almost any circuit shown using a triode, tetrode, or pentode tube type is equally suitable for any other tube type in the same generic group, provided the necessary revisions are made to meet the ratings of the tube used.

The capacitance values given for the various tuned circuits are in terms of  $\mu\mu\text{f}$  per meter of wavelength, and are the actual capacitances in use—not the maximum capacitance of the condensers. The value of inductance in each case is determined principally by the total shunt capacitance and by the operating frequency. The indicated capacitance values, in most cases, are chosen for an operating Q of 12, which is suitable for amateur transmitters intended for either telephony or telegraphy. Some other applications may require a somewhat higher Q for telephony.

Information on the characteristics and the application features of each tube, given under each tube type, will prove of assistance in the understanding and the utilization of these circuits. Frequent reference to the chapters on INSTALLATION, APPLICATION, and TRANSMITTER DESIGN CONSIDERATIONS will also prove helpful.

(1)

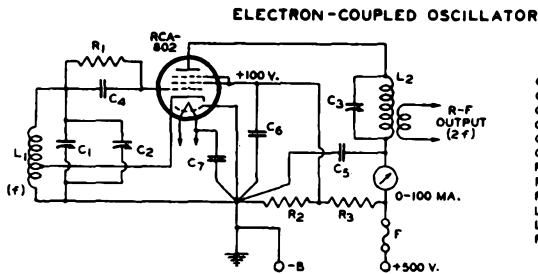

$C_1 = 4 \mu\mu\text{f} / \text{METER}$   
 $C_2 = \text{TRIMMER CONDENSER}$   
 $C_3 = 2 \mu\mu\text{f} / \text{METER}$   
 $C_4 = 0.00025 \mu\text{f}, \text{MICA}$   
 $C_5, C_7 = 0.005 \mu\text{f}, \text{MICA}$   
 $C_6 = 0.01 \mu\text{f}, \text{MICA}$   
 $C_8 = 0.01 \mu\text{f}, \text{MICA}$   
 $R_1 = 25000 \text{ OHMS}, 1 \text{ WATT}$   
 $R_2 = 20000 \text{ OHMS}, 5 \text{ WATTS}$   
 $R_3 = 20000 \text{ OHMS}, 10 \text{ WATTS}$   
 $L_1 = \text{TUNE TO FREQUENCY "f"}$   
 $L_2 = \text{TUNE TO FREQUENCY "2f"}$   
 $F = \frac{1}{2} \text{A. HIGH-VOLTAGE FUSE}$

(2)

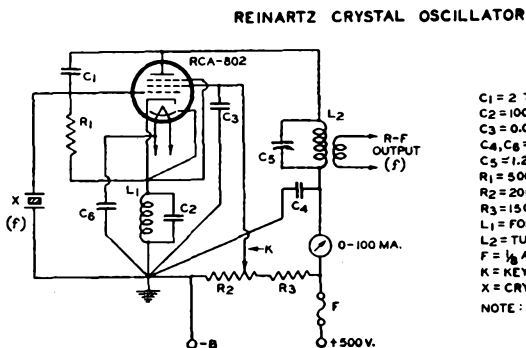

$C_1 = 2 \text{ TO } 3 \mu\mu\text{f}, 1200 \text{ VOLTS}$   
 $C_2 = 100 \mu\mu\text{f}, \text{MICA}$   
 $C_3 = 0.01 \mu\text{f}, \text{MICA}$   
 $C_4, C_6 = 0.005 \mu\text{f}, \text{MICA}$   
 $C_5 = 1.2 \mu\text{f} / \text{METER}$   
 $R_1 = 5000 \text{ OHMS}, \text{WIRE-WOUND}$   
 $R_2 = 20000 \text{ OHMS}, 10 \text{ WATTS}$   
 $R_3 = 15000 \text{ OHMS}, 10 \text{ WATTS}$   
 $L_1 = \text{FOR } \frac{1}{2} \text{ CRYSTAL FREQUENCY, WITH } C_2$   
 $L_2 = \text{TUNE TO FREQUENCY "f"}$   
 $F = \frac{1}{2} \text{A. HIGH-VOLTAGE FUSE}$   
 $K = \text{KEY HERE, OPTIONAL}$   
 $X = \text{CRYSTAL, FREQUENCY "f"}$   
 NOTE: ADJUST SCREEN VOLTAGE FOR OPTIMUM OUTPUT.

(3)

**PUSH-PULL CRYSTAL OSCILLATOR**  
POWER OUTPUT 30 WATTS (APPROX.)

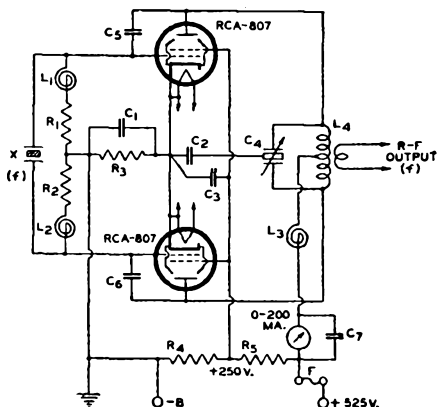

$C_1, C_2, C_3, C_7 = 0.005 \mu\text{f}$ , MICA  
 $C_4 = 2.0 \mu\text{mf}$  / METER / SECTION  
 $C_5, C_6 = 1$  TO  $2 \mu\text{mf}$  (NOT LARGER), 1000V.  
 $R_1, R_2 = 50000$  OHMS, 1 WATT  
 $R_3 = 200$  OHMS, 20 WATTS  
 $R_4 = 15000$  OHMS, 10 WATTS  
 $R_5 = 8000$  OHMS, 25 WATTS  
 $L_1, L_2, L_3 = \text{R-F CHOKE}$   
 $L_4 = \text{TUNE TO CRYSTAL FREQUENCY}$   
 $F = \frac{1}{4}$  A. HIGH-VOLTAGE FUSE  
 $X = \text{CRYSTAL, FREQUENCY "f"}$

(4)

**FREQUENCY DOUBLER OR R-F POWER AMPLIFIER**  
AMPLIFIER POWER OUTPUT 140 WATTS (APPROX.)  
(CLASS C TELEGRAPHY)

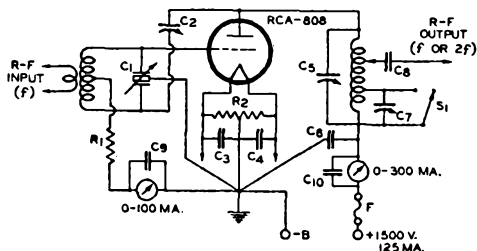

$C_1 = 1 \mu\text{mf}$  / METER / SECTION  
 $C_2 = 3 \mu\text{mf}$  (APPROX.), 4000 VOLTS  
 $C_3, C_4, C_9, C_{10} = 0.005 \mu\text{f}$ , MICA  
 $C_5 = 1.2 \mu\text{mf}$  / METER  
 $C_6 = 0.005 \mu\text{f}$ , 2000 VOLTS  
 $C_7 = \text{TRIMMER CONDENSER}$   
 $C_8 = 250 \mu\text{mf}$ , HIGH-VOLTAGE MICA  
 $R_1 = 7000$  OHMS, 10 WATTS  
 $R_2 = 50$  OHMS, C.T. WIRE-WOUND  
 $F = \frac{1}{4}$  A. HIGH-VOLTAGE FUSE  
 $S_1 = \text{FREQUENCY-CHANGE SWITCH}$   
 NOTE:  $C_7$  AND  $S_1$  ARE OPTIONAL,  
 FOR FREQUENCY CHANGING.

(5)

**FREQUENCY DOUBLER-QUADRUPLER**

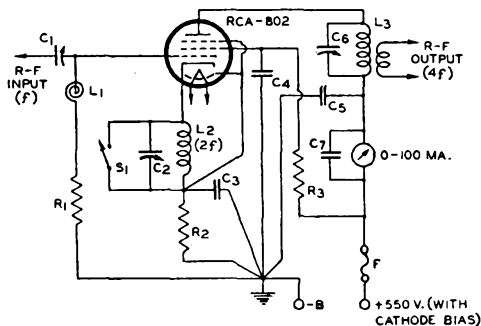

$C_1 = 50 \mu\text{mf}$ , APPROX.  
 $C_2 = 1 \mu\text{mf}$  / METER  
 $C_3, C_4, C_5, C_7 = 0.005 \mu\text{f}$ , MICA  
 $C_6 = 1.2 \mu\text{mf}$  / METER  
 $R_1 = 8000$  OHMS, 1 WATT  
 $R_2 = 800$  OHMS, 10 WATTS  
 $R_3 = 14000$  OHMS, 20 WATTS  
 $L_1 = \text{R-F CHOKE}$   
 $L_2 = \text{FOR } 2f$ , WITH  $C_2$   
 $S_1 = \text{S.P.S.T. SWITCH}$   
 $F = \frac{1}{8}$  A. HIGH-VOLTAGE FUSE  
 NOTE: CIRCUIT IS SHOWN FOR  
 FREQUENCY QUADRUPLING,  
 FOR DOUBLING, CLOSE  $S_1$   
 AND TUNE  $L_3$   $C_6$  TO  
 FREQUENCY "2f"

(6)

REINARTZ HARMONIC GENERATOR

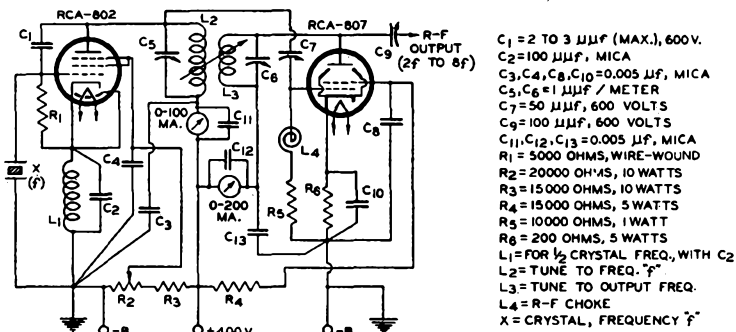

- C<sub>1</sub> = 2 TO 3 μμf (MAX.), 600V.
- C<sub>2</sub> = 100 μμf, MICA
- C<sub>3</sub>, C<sub>4</sub>, C<sub>8</sub>, C<sub>10</sub> = 0.005 μμf, MICA
- C<sub>5</sub>, C<sub>6</sub> = 1 μμf / METER
- C<sub>7</sub> = 50 μμf, 600 VOLTS
- C<sub>9</sub> = 100 μμf, 600 VOLTS
- C<sub>11</sub>, C<sub>12</sub>, C<sub>13</sub> = 0.005 μμf, MICA
- R<sub>1</sub> = 5000 OHMS, WIRE-WOUND
- R<sub>2</sub> = 20000 OHMS, 10 WATTS
- R<sub>3</sub> = 15000 OHMS, 10 WATTS
- R<sub>4</sub> = 15000 OHMS, 5 WATTS
- R<sub>5</sub> = 10000 OHMS, 1 WATT
- R<sub>6</sub> = 200 OHMS, 5 WATTS
- L<sub>1</sub> = FOR 1/2 CRYSTAL FREQ., WITH C<sub>2</sub>
- L<sub>2</sub> = TUNE TO FREQ. "f"
- L<sub>3</sub> = TUNE TO OUTPUT FREQ.
- L<sub>4</sub> = R-F CHOKE
- X = CRYSTAL, FREQUENCY "f"

NOTE: ADJUST COUPLING OF L<sub>2</sub> AND L<sub>3</sub> FOR MAXIMUM HARMONIC OUTPUT. CORRECT POLARIZATION OF L<sub>2</sub> AND L<sub>3</sub> IS ESSENTIAL.

(7)

PUSH-PUSH FREQUENCY DOUBLER OF HIGH EFFICIENCY  
POWER OUTPUT 65 WATTS (APPROX.)

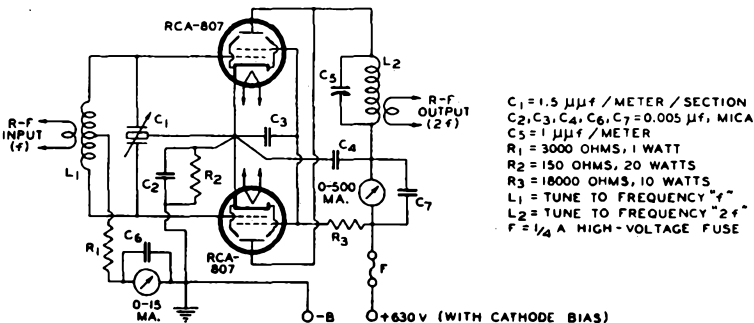

- C<sub>1</sub> = 1.5 μμf / METER / SECTION
- C<sub>2</sub>, C<sub>3</sub>, C<sub>4</sub>, C<sub>6</sub>, C<sub>7</sub> = 0.005 μμf, MICA
- C<sub>5</sub> = 1 μμf / METER
- R<sub>1</sub> = 3000 OHMS, 1 WATT
- R<sub>2</sub> = 150 OHMS, 20 WATTS
- R<sub>3</sub> = 18000 OHMS, 10 WATTS
- L<sub>1</sub> = TUNE TO FREQUENCY "f"
- L<sub>2</sub> = TUNE TO FREQUENCY "2f"
- F = 1/4 A HIGH-VOLTAGE FUSE

(8)

BEAM POWER R-F AMPLIFIER OR FREQUENCY DOUBLER  
AMPLIFIER POWER OUTPUT 37 WATTS (APPROX.)

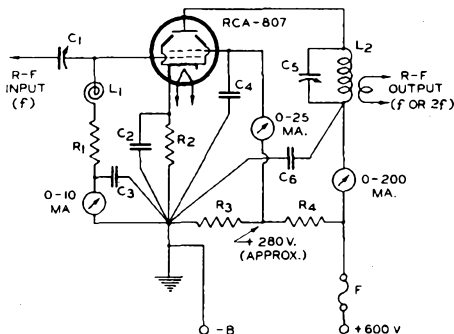

- C<sub>1</sub> = 50 μμf, MIDGET
- C<sub>2</sub>, C<sub>3</sub>, C<sub>4</sub>, C<sub>6</sub> = 0.005 μμf, MICA
- C<sub>5</sub> = 2 μμf / METER, 1200 VOLTS
- R<sub>1</sub> = 10000 OHMS, 1 WATT
- R<sub>2</sub> = 250 OHMS, 5 WATTS
- R<sub>3</sub> = 35000 OHMS, 10 WATTS
- R<sub>4</sub> = 20000 OHMS, 10 WATTS
- L<sub>1</sub> = R-F CHOKE
- F = 1/8 A. HIGH-VOLTAGE FUSE

NOTE FOR FREQUENCY DOUBLING, TUNE C<sub>5</sub> L<sub>2</sub> TO FREQUENCY "2f". A 40000-OHM, 10-WATT SERIES SCREEN RESISTOR CAN BE USED IN PLACE OF R<sub>3</sub> AND R<sub>4</sub>.

(9)

**PUSH-PULL CLASS C R-F AMPLIFIER FOR C-W TELEGRAPHY**  
 POWER OUTPUT 50 WATTS (APPROX.)

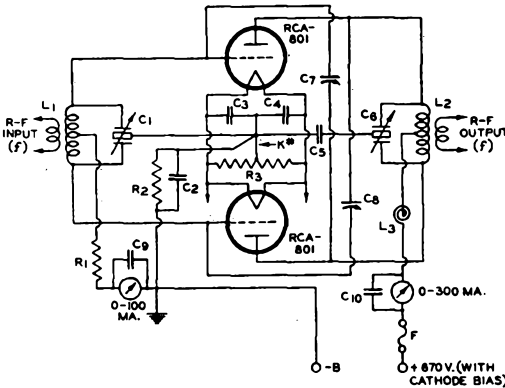

- C<sub>1</sub> = 1.2 μμf / METER / SECTION
- C<sub>2</sub> = 0.005 μf, MICA \*
- C<sub>3</sub>, C<sub>4</sub>, C<sub>5</sub>, C<sub>9</sub>, C<sub>10</sub> = 0.005 μf, MICA
- C<sub>6</sub> = 1.4 μμf / METER / SECTION
- C<sub>7</sub>, C<sub>8</sub> = 8 μμf (APPROX.) 3000 V.
- R<sub>1</sub> = 2700 OHMS, 5 WATTS
- R<sub>2</sub> = 400 OHMS, 20 WATTS
- R<sub>3</sub> = 50 OHMS, C.T., WIRE-WOUND
- L<sub>1</sub>, L<sub>2</sub> = TUNE TO FREQUENCY F\*
- L<sub>3</sub> = R-F CHOKE
- F = 1/4 A. HIGH-VOLTAGE FUSE
- K = KEY HERE \*

\*C<sub>2</sub> SHOULD BE SHUNTED BY A LARGE A-F BY-PASS CONDENSER WHEN THE 801'S ARE MODULATED. THE PLATE AND BIAS VOLTAGES SHOULD BE CHANGED ACCORDING TO PUBLISHED RATINGS FOR THE 801 IN MODULATED SERVICE

• WARNING — THE HIGH D-C VOLTAGE WILL APPEAR ACROSS THE OPEN KEY CONTACTS.

(10)

**GRID-MODULATED R-F AMPLIFIER**  
 POWER OUTPUT 60 WATTS (APPROX.)

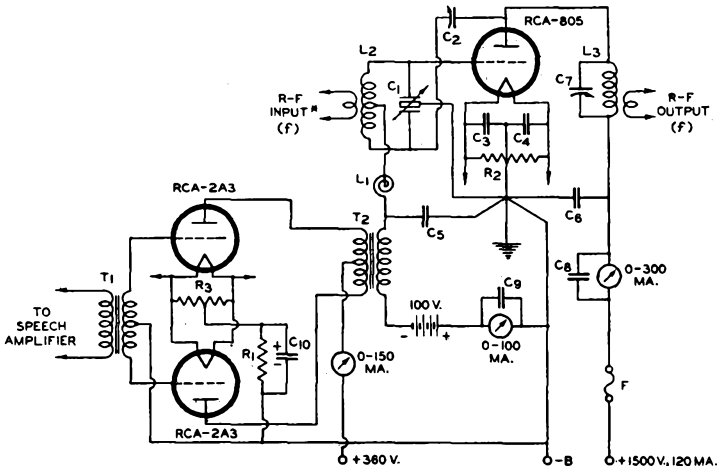

- C<sub>1</sub> = 1.5 μμf / METER / SECTION
- C<sub>2</sub> = 8.5 μμf (APPROX.), 4000 V.
- C<sub>3</sub>, C<sub>4</sub>, C<sub>6</sub>, C<sub>9</sub> = 0.005 μf, MICA
- C<sub>5</sub> = 0.0005 μf, MICA
- C<sub>8</sub> = 0.005 μf, 2000 V.
- C<sub>7</sub> = 1.0 μμf / METER
- C<sub>10</sub> = 25 TO 50 μf, 100 V.
- R<sub>1</sub> = 775 OHMS, 10 WATTS

- R<sub>2</sub> = 50 OHMS, C.T., WIRE-WOUND
- R<sub>3</sub> = 20 OHMS, C.T., WIRE-WOUND
- L<sub>1</sub> = R-F CHOKE
- L<sub>2</sub>, L<sub>3</sub> = TUNE TO FREQUENCY F\*
- T<sub>1</sub> = INTERSTAGE A-F TRANSFORMER
- T<sub>2</sub> = MODULATION TRANSFORMER
- F = 3/16 A. HIGH-VOLTAGE FUSE

\*THE R-F DRIVER SHOULD HAVE GOOD R-F VOLTAGE REGULATION UNDER THE VARYING LOAD OF THE GRID-MODULATED STAGE.

(11)

PLATE-MODULATED TETRODE R-F AMPLIFIER  
POWER OUTPUT 100 WATTS (APPROX.)

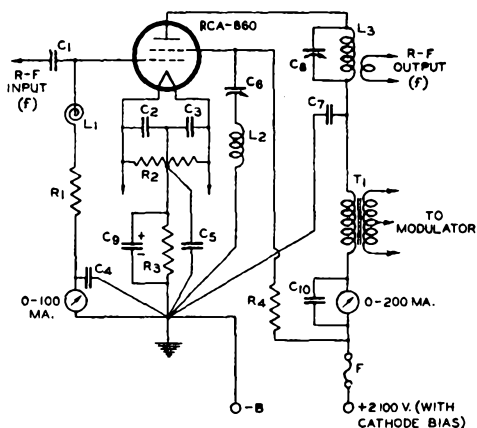

- C<sub>1</sub> = 0.0005  $\mu$ F, HIGH-VOLTAGE
  - C<sub>2</sub>, C<sub>3</sub>, C<sub>4</sub>, C<sub>5</sub>, C<sub>10</sub> = 0.005  $\mu$ F, MICA
  - C<sub>6</sub> = SEE NOTE
  - C<sub>7</sub> = 0.002  $\mu$ F, 5000 VOLTS
  - C<sub>8</sub> = 0.6  $\mu$ F/METER
  - C<sub>9</sub> = 25  $\mu$ F, 200 VOLTS
  - R<sub>1</sub> = 2500 OHMS, 10 WATTS
  - R<sub>2</sub> = 50 OHMS, C.T., WIRE-WOUND
  - R<sub>3</sub> = 800 OHMS, 20 WATTS
  - R<sub>4</sub> = 100000 OHMS, 50 WATTS
  - L<sub>1</sub> = R-F CHOKE
  - L<sub>2</sub>, L<sub>3</sub> = TUNE TO FREQUENCY  $f$
  - T<sub>1</sub> = MODULATION TRANSFORMER
  - F = 1/8 A. HIGH-VOLTAGE FUSE
- NOTE: C<sub>6</sub> L<sub>2</sub> IS SERIES TUNED TO CARRIER FREQUENCY C<sub>6</sub> SHOULD HAVE A 2500-VOLT RATING.

(12)

PUSH-PULL TETRODE R-F POWER AMPLIFIER  
POWER OUTPUT 1400 WATTS (APPROX.)  
(CLASS C TELEGRAPHY)

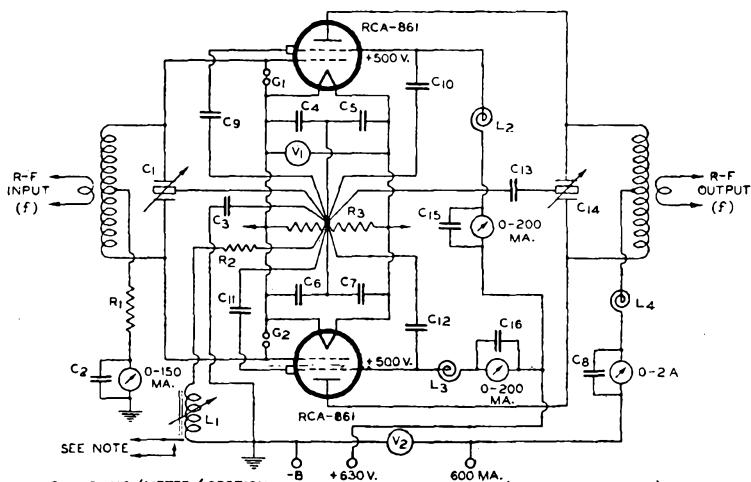

- C<sub>1</sub> = 1.5  $\mu$ F/METER/SECTION
- C<sub>2</sub> TO C<sub>8</sub> = 0.005  $\mu$ F, MICA
- C<sub>9</sub> TO C<sub>13</sub> = 0.01  $\mu$ F, 5000 VOLTS
- C<sub>14</sub> = 1  $\mu$ F/METER/SECTION
- C<sub>15</sub>, C<sub>16</sub> = 0.005  $\mu$ F, MICA
- R<sub>1</sub> = 1500 OHMS, 20 WATTS
- R<sub>2</sub> = 200 OHMS, 200 WATTS
- R<sub>3</sub> = 50 OHMS, C.T., WIRE-WOUND, 25 WATTS

- L<sub>1</sub> = SEE NOTE
- L<sub>2</sub>, L<sub>3</sub> = R-F CHOKE, 50 MA.
- L<sub>4</sub> = R-F CHOKE, 1.0 AMPERE
- G<sub>1</sub>, G<sub>2</sub> = SPARK GAP, 1/8" SPACING (APPROX.)
- V<sub>1</sub> = 0-15 V. A-C VOLTMETER
- V<sub>2</sub> = 0-5000 V. D-C VOLTMETER

NOTE L<sub>1</sub> IS AN ADJUSTABLE, LOW-RESISTANCE D-C OVERLOAD RELAY SET TO OPEN THE PRIMARY CIRCUIT OF THE HIGH-VOLTAGE POWER TRANSFORMER WHEN THE CATHODE CURRENT REACHES 1.1 AMPERES

(13)

**PUSH-PULL PENTODE PLATE-MODULATED R-F POWER AMPLIFIER**  
 POWER OUTPUT 250 WATTS (APPROX.)

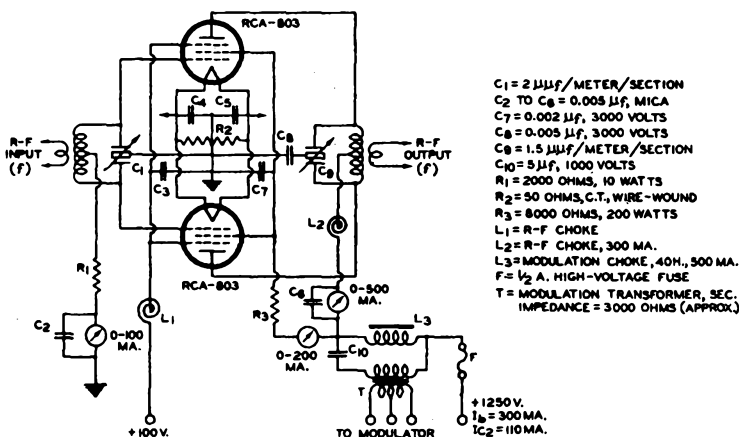

- C<sub>1</sub> = 2 μμf/METER/SECTION
- C<sub>2</sub> TO C<sub>8</sub> = 0.005 μf, MICA
- C<sub>7</sub> = 0.002 μf, 3000 VOLTS
- C<sub>9</sub> = 0.005 μf, 3000 VOLTS
- C<sub>9</sub> = 1.5 μμf/METER/SECTION
- C<sub>10</sub> = 5 μf, 1000 VOLTS
- R<sub>1</sub> = 2000 OHMS, 10 WATTS
- R<sub>2</sub> = 50 OHMS, C.T., WIRE-WOUND
- R<sub>3</sub> = 8000 OHMS, 200 WATTS
- L<sub>1</sub> = R-F CHOKE
- L<sub>2</sub> = R-F CHOKE, 300 MA.
- L<sub>3</sub> = MODULATION CHOKE, 40H., 500 MA.
- F = 1/2 A. HIGH-VOLTAGE FUSE
- T = MODULATION TRANSFORMER, SEC. IMPEDANCE = 3000 OHMS (APPROX.)

NOTE: SPECIAL ATTENTION SHOULD BE GIVEN TO THE SHIELDING OF THE INPUT CIRCUIT FROM THE OUTPUT CIRCUIT. REFER TO TYPE 803.

(14)

**SUPPRESSOR-MODULATED PENTODE R-F POWER AMPLIFIER**  
 POWER OUTPUT 21 WATTS (APPROX.)

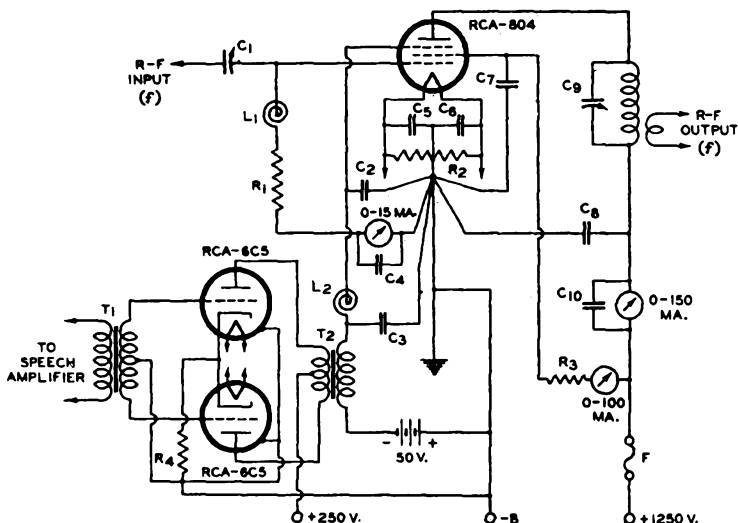

- C<sub>1</sub> = 100 μμf, MIDGET
- C<sub>2</sub>, C<sub>3</sub> = 0.001 μf, MICA
- C<sub>4</sub>, C<sub>5</sub>, C<sub>8</sub>, C<sub>10</sub> = 0.005 μf, MICA
- C<sub>7</sub> = 0.002 μf, 1500 VOLTS
- C<sub>8</sub> = 0.005 μf, 1500 VOLTS
- C<sub>9</sub> = 0.5 μμf/METER
- R<sub>1</sub> = 15000 OHMS, 2 WATTS

- R<sub>2</sub> = 50 OHMS, C.T., WIRE-WOUND
- R<sub>3</sub> = 27000 OHMS, 50 WATTS
- R<sub>4</sub> = 500 OHMS, 0.5 WATT
- L<sub>1</sub>, L<sub>2</sub> = R-F CHOKE
- T<sub>1</sub> = A-F TRANSFORMER
- T<sub>2</sub> = MODULATION TRANSFORMER, RATIO P/S = 3.0
- F = 1/2 A. HIGH-VOLTAGE FUSE



(15)

LOW-POWER HIGH-FREQUENCY TRANSMITTER  
CLASS C TELEGRAPHY POWER OUTPUT 55 WATTS (APPROX)

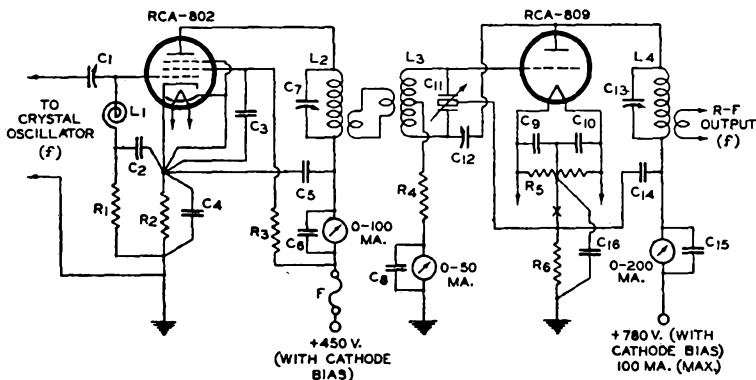

C<sub>1</sub> = 50 μμf, MIDGET  
C<sub>2</sub> TO C<sub>6</sub> = 0.005 μf, MICA  
C<sub>7</sub>, C<sub>13</sub> = 1.5 μμf/METER  
C<sub>8</sub>, C<sub>9</sub>, C<sub>10</sub>, C<sub>15</sub> = 0.005 μf, MICA  
C<sub>11</sub> = 1 μμf/METER/SECTION  
C<sub>12</sub> = 6.7 μμf (APPROX.) 2000 VOLTS  
C<sub>14</sub> = 0.002 μf, 1000 VOLTS  
C<sub>16</sub> = 0.005 μf, 1000 VOLTS  
R<sub>1</sub> = 7000 OHMS, 2 WATTS

R<sub>2</sub> = 650 OHMS, 10 WATTS  
R<sub>3</sub> = 8000 OHMS, 10 WATTS  
R<sub>4</sub> = 1500 OHMS, 2 WATTS  
R<sub>5</sub> = 40 OHMS, C.T., WIRE-WOUND  
R<sub>6</sub> = 250 OHMS, 10 WATTS  
L<sub>1</sub> = R-F CHOKE  
L<sub>2</sub>, L<sub>3</sub>, L<sub>4</sub> = TUNE TO FREQUENCY f<sup>\*</sup>  
F = 1/8 A. HIGH-VOLTAGE FUSE  
X = INSERT KEYING RELAY HERE

(16)

PUSH-PULL CLASS C R-F AMPLIFIER\*  
POWER OUTPUT 1270 WATTS (APPROX.)

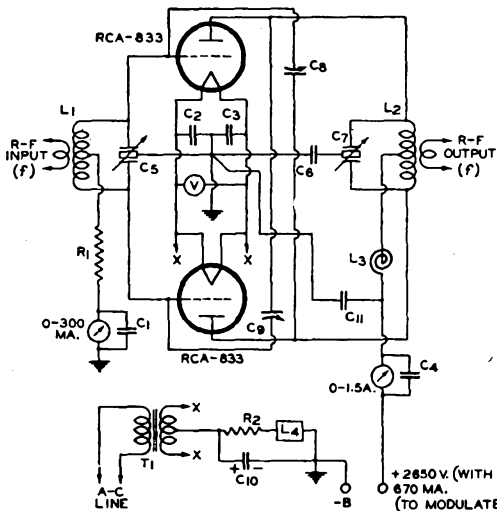

C<sub>1</sub> TO C<sub>4</sub> = 0.005 μf, MICA  
C<sub>5</sub> = 1 μμf/METER/SECTION  
C<sub>6</sub> = 0.005 μf, 7500 VOLTS  
C<sub>7</sub> = 2 μμf/METER/SECTION  
C<sub>8</sub>, C<sub>9</sub> = 6.3 μμf (APPROX.)  
C<sub>10</sub> = 50 μf, 250 VOLTS  
C<sub>11</sub> = 0.005 μf, 7500 VOLTS  
R<sub>1</sub> = 1000 OHMS, 50 WATTS  
R<sub>2</sub> = 170 OHMS, 200 WATTS  
L<sub>1</sub>, L<sub>2</sub> = TUNE TO FREQUENCY f<sup>\*</sup>  
L<sub>3</sub> = R-F CHOKE, 1 AMPERE  
L<sub>4</sub> = SEE NOTE (1)  
T<sub>1</sub> = FILAMENT TRANSFORMER  
Ⓢ = 0-15V. A-C VOLTMETER

NOTE (1) L<sub>4</sub> IS A 12-OHM D-C OVERLOAD RELAY SET TO OPEN THE PRIMARY CIRCUIT OF THE HIGH-VOLTAGE TRANSFORMER WHEN THE D-C CATHODE CURRENT REACHES 1.2 AMPERES.

\* CIRCUIT VALUES SHOWN ARE FOR PLATE-MODULATED TELEPHONY SERVICE.

(17)

C-W TELEGRAPH TRANSMITTER\*  
POWER OUTPUT 275 WATTS (APPROX.)

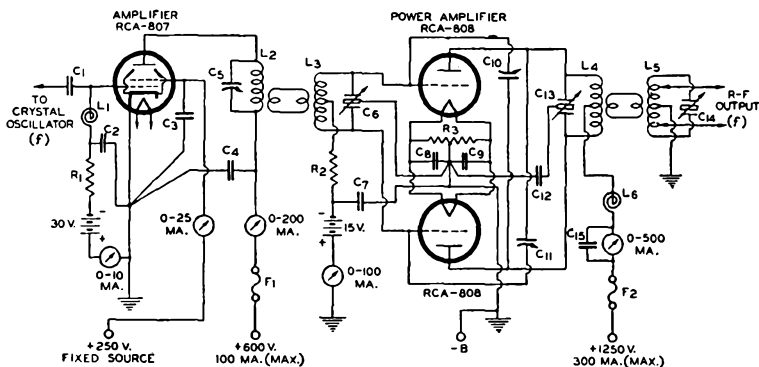

- C1 = 50 μμf, MICA
- C2, C3, C4 = 0.005 μf, MICA
- C5 = 2 μμf/METER, 1200 V.
- C6 = 2 μμf/METER/SECTION
- C7, C8, C9 = 0.005 μf, MICA
- C10, C11 = 3 μμf (APPROX.), 3000 V.
- C12 = 0.005 μf, 2000 V.
- C13 = 1.0 μμf/METER/SECTION, 1500 V.
- C14 = SEE L5
- C15 = 0.005 μf, MICA
- R1 = 7000 OHMS, 1 WATT

- R2 = 2200 OHMS, 20 WATTS
- R3 = 50 OHMS, C.T., WIRE-WOUND
- L1 = R-F CHOKE
- L2, L3, L4 = TUNE TO FREQUENCY "F"
- L5 = VALUE DEPENDS ON ANTENNA ARRANGEMENT AND ON THE OPERATING FREQUENCY
- L6 = R-F CHOKE, 300 MA.
- F1 = 1/8 A. HIGH-VOLTAGE FUSE
- F2 = 3/8 A. HIGH-VOLTAGE FUSE
- "F" = CRYSTAL FREQUENCY

\* BECAUSE PARTIAL FIXED BIAS IS USED ON THE AMPLIFIER STAGES, THE CRYSTAL OSCILLATOR MAY BE KEYPED FOR "BREAK-IN" OPERATION. SCREEN VOLTAGE FOR THE OSCILLATOR AND FOR THE 807 SHOULD BE OBTAINED FROM A FIXED SOURCE HAVING GOOD VOLTAGE REGULATION.

(18)

HIGH-FREQUENCY TRANSMITTER

CLASS C PLATE-MODULATED TELEPHONY POWER OUTPUT, 280 WATTS (APPROX.)  
CLASS C TELEGRAPHY POWER OUTPUT, 430 WATTS (APPROX.)

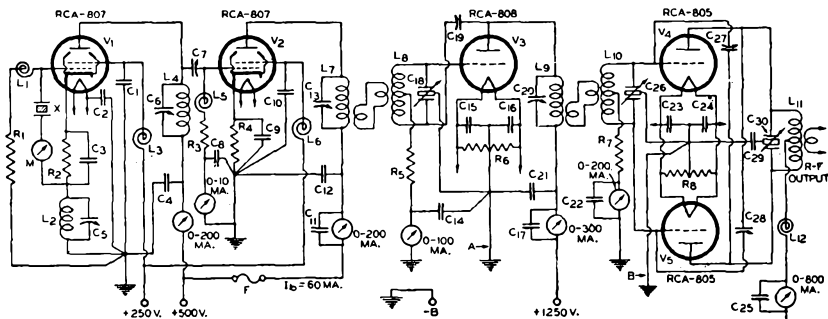

- C1 TO C4 = 0.005 μf, MICA
- C5, C6 = 1.0 μμf/METER
- C7 = 50 μμf, WIDGET
- C8 TO C12 = 0.005 μf, MICA
- C13 = 1.5 μμf/METER
- C14 TO C17 = 0.005 μf, MICA
- C18 = 1 μμf/METER/SECTION
- C19 = 3 μμf (APPROX.), 3000 VOLTS
- C20 = 1.5 μμf/METER
- C21 = 0.002 μf, 1500 VOLTS
- C22 TO C25 = 0.005 μf, MICA
- C26 = 1 μμf/METER/SECTION
- C27, C28 = 6.5 μμf (APPROX.)

- C29 = 0.002 μf, 3000 VOLTS
- C30 = 1.5 μμf/METER/SECTION
- R1 = 50000 OHMS, 1 WATT
- R2 = 400 OHMS, 5 WATTS
- R3 = 10000 OHMS, 1 WATT
- R4 = 250 OHMS, 5 WATTS
- R5 = 5000 OHMS, 10 WATTS
- R6 = 50 OHMS, C.T., WIRE-WOUND
- R7 = 1300 OHMS, 50 WATTS
- R8 = 50 OHMS, C.T., WIRE-WOUND
- L1, L3, L5, L6 = R-F CHOKE
- L2 = TUNE TO FREQ. 1.5F (APPROX.)
- L4 = TUNE TO FREQUENCY "2F"

- L7 TO L11 = TUNE TO FREQ. 2f
- L12 = R-F CHOKE, 500 MA.
- M = 0-15 MA. THERMOGALVANOMETER
- V1 = CRYSTAL OSCILLATOR, DOUBLER<sup>†</sup>
- V2 = R-F AMPLIFIER OR FREQ. DOUBLER<sup>†</sup>
- V3 = R-F AMPLIFIER, DRIVER
- V4, V5 = R-F POWER AMPLIFIER
- X = CRYSTAL, FREQUENCY "F"
- F = 1/2 A. HIGH-VOLTAGE FUSE
- A, B = INSERT D-C OVERLOAD RELAY, BY-PASSED FOR RADIO FREQUENCY

NOTE: CRYSTAL FREQUENCY "F" MAY BE AS HIGH AS 7 MC., FOR 20-MC. OPERATION OF THE FINAL AMPLIFIER.  
† THE "TRITET" TYPE OF OSCILLATOR CIRCUIT WAS ORIGINALLY DESCRIBED BY MR. J. LAMB IN QST.

(19)

CLASS B MODULATOR  
A-F POWER OUTPUT 45 WATTS

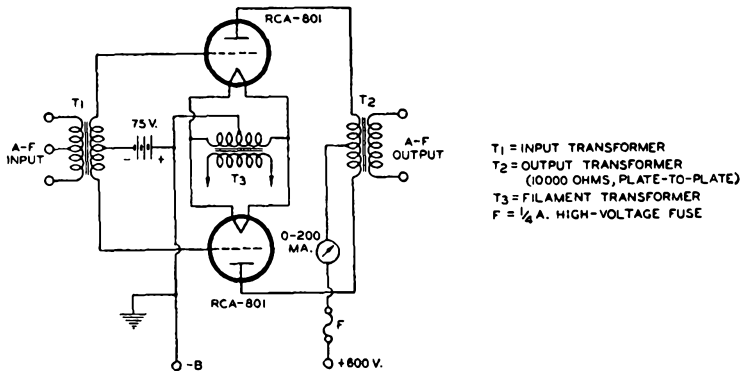

T<sub>1</sub> = INPUT TRANSFORMER  
T<sub>2</sub> = OUTPUT TRANSFORMER  
(10000 OHMS, PLATE-TO-PLATE)  
T<sub>3</sub> = FILAMENT TRANSFORMER  
F = 1/4 A. HIGH-VOLTAGE FUSE

(20)

14-MC PLATE-MODULATED PENTODE R-F AMPLIFIER\*  
POWER OUTPUT 155 WATTS (APPROX.)

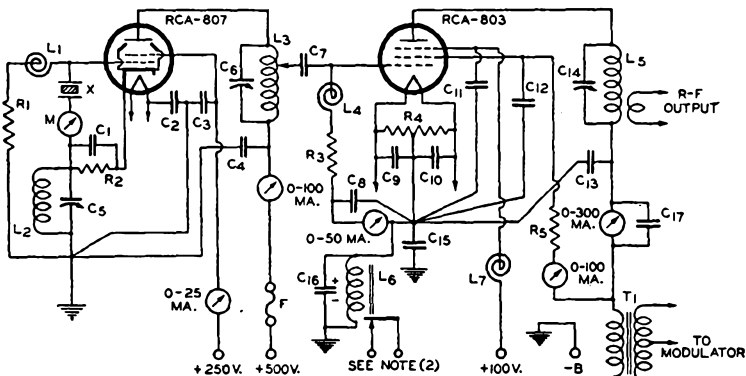

C<sub>1</sub> TO C<sub>4</sub> = 0.005 μf, MICA  
C<sub>5</sub> = 50 μμf, MIDGET  
C<sub>6</sub> = 25 μμf (APPROX.)  
C<sub>7</sub> = 0.0005 μf, MICA  
C<sub>8</sub>, C<sub>9</sub>, C<sub>10</sub>, C<sub>11</sub>, C<sub>15</sub>, C<sub>17</sub> = 0.005 μf, MICA  
C<sub>12</sub> = 0.002 μf, 3000 VOLTS  
C<sub>13</sub> = 0.002 μf, 5000 VOLTS  
C<sub>14</sub> = 25 μμf  
C<sub>16</sub> = 8 TO 16 μf, ELECTROLYTIC  
R<sub>1</sub> = 50000 OHMS, 1 WATT  
R<sub>2</sub> = 400 OHMS, 10 WATTS

R<sub>3</sub> = 4000 OHMS, 5 WATTS  
R<sub>4</sub> = 50 OHMS, C.T., WIRE-WOUND  
R<sub>5</sub> = 20000 OHMS, 100 WATTS  
L<sub>1</sub>, L<sub>4</sub>, L<sub>7</sub> = R-F CHOKE  
L<sub>2</sub> = SEE NOTE (1)  
L<sub>3</sub>, L<sub>5</sub> = TUNE TO 14 MC. (APPROX.)  
L<sub>6</sub> = SEE NOTE (2)  
F = 1/8 A. HIGH-VOLTAGE FUSE  
M = 0-115 MA. THERMOGALVANOMETER  
T<sub>1</sub> = MODULATION TRANSFORMER  
X = 7-MC. (APPROX.) CRYSTAL

NOTE (1): L<sub>2</sub> SHOULD HAVE CONSIDERABLY LESS INDUCTANCE THAN THE USUAL 7-MC. TANK COIL.

NOTE (2): L<sub>6</sub> IS A LOW-RESISTANCE D-C OVERLOAD RELAY, SET TO OPEN THE PRIMARY CIRCUIT OF THE HIGH-VOLTAGE SUPPLY WHEN THE CATHODE CURRENT REACHES 300 MA. (APPROX.)

\*OR LARGER, IF NECESSARY TO PREVENT FEED-BACK.

\*THE "TRITET" TYPE OF OSCILLATOR CIRCUIT WAS ORIGINALLY DESCRIBED BY MR. J. J. LAMB IN "QST".

(21)

CLASS B LINEAR R-F POWER AMPLIFIER  
POWER OUTPUT 140 WATTS (APPROX.)

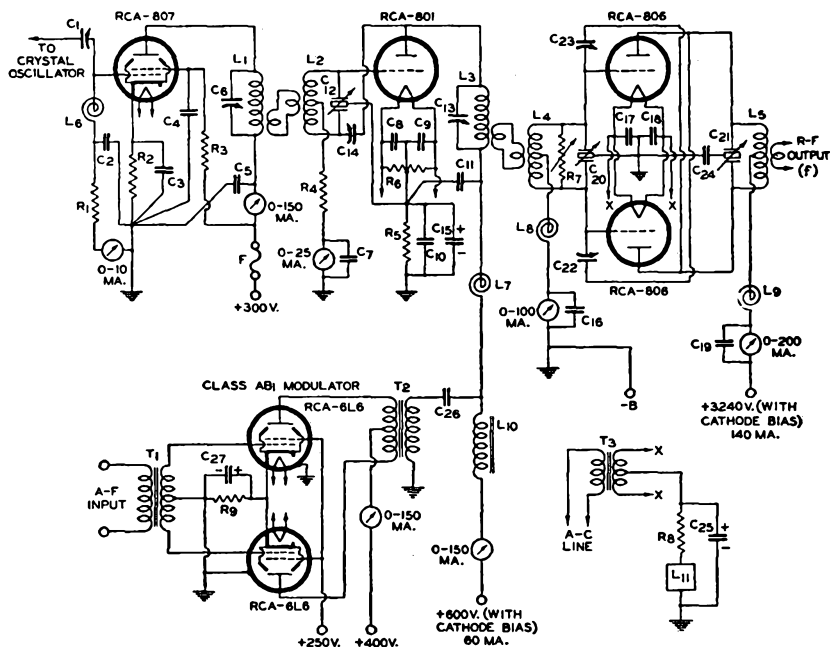

- C1 = 50  $\mu$ f
- C2 TO C5 = 0.005  $\mu$ f, MICA
- C6 = 2  $\mu$ f/METER
- C7 TO C11 = 0.005  $\mu$ f, MICA
- C12, C21 = 1  $\mu$ f/METER/SECTION
- C13 = 1.5  $\mu$ f/METER
- C14 = 6  $\mu$ f (APPROX.)
- C15 = 25  $\mu$ f, 250 VOLTS
- C16 TO C19 = 0.005  $\mu$ f, MICA
- C20 = 2  $\mu$ f/METER/SECTION
- C22, C23 = 3.4  $\mu$ f (APPROX.)
- C24 = 0.005  $\mu$ f, 5000 VOLTS
- C25 = 25  $\mu$ f, 450 VOLTS
- C26 = 2  $\mu$ f, 1000 VOLTS
- C27 = 50  $\mu$ f, 35 VOLTS
- R1 = 8000 OHMS, 1 WATT
- R2 = 400 OHMS, 5 WATTS
- R3 = 5000 OHMS, 2 WATTS

- R4 = 6000 OHMS, 5 WATTS
  - R5 = 1300 OHMS, 20 WATTS
  - R6 = 50 OHMS, C.T., WIRE-WOUND
  - R7 = NON-INDUCTIVE GRID-REGULATION RESISTOR
  - R8 = 1850 OHMS, 100 WATTS
  - R9 = 190 OHMS, 5 WATTS
  - L1 TO L5 = TUNE TO FREQUENCY  $f$
  - L6 TO L9 = R-F CHOKE.
  - L10 = 120 HENRIES, 80 MA.
  - L11 = D-C OVERLOAD RELAY, 50 OHMS
  - T1 = INTERSTAGE A-F TRANSFORMER
  - T2 = MODULATION TRANSFORMER, PLATE-TO-PLATE IMPEDANCE = 8500 OHMS, RATIO, PRI./SEC. = 1
  - T3 = FILAMENT TRANSFORMER
  - F = 1/8 A. HIGH-VOLTAGE FUSE
- NOTE: L11 SHOULD BE CONNECTED TO PROTECT THE 801 AS WELL AS THE 806'S.

(22)

**SPEECH AMPLIFIER AND DRIVER WITH NEGATIVE-PEAK AUTOMATIC MODULATION CONTROL AND TWO-CHANNEL ELECTRIC MIXER\***  
POWER OUTPUT 10 WATTS (APPROX.)

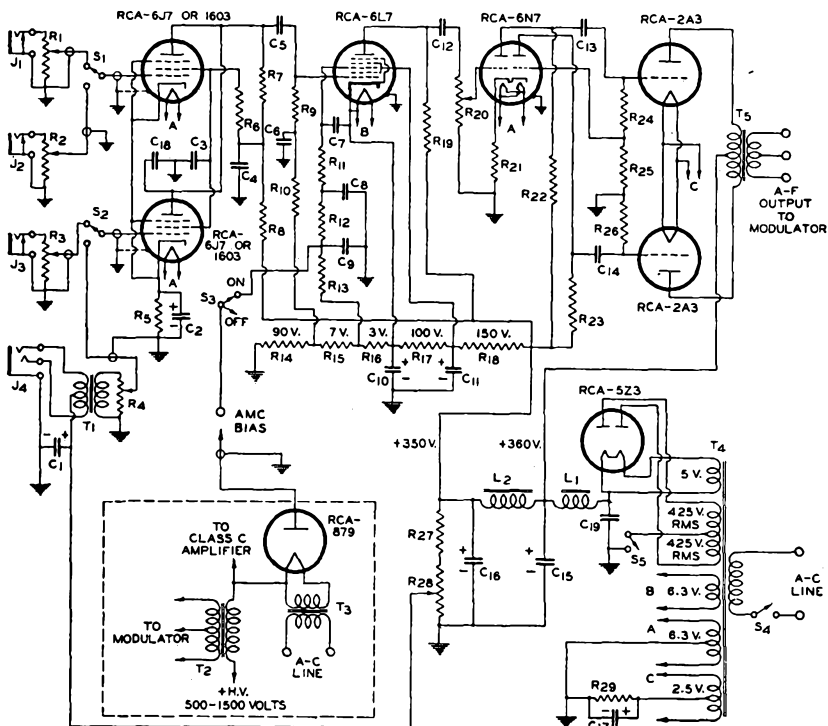

- C<sub>1</sub> = 25 μf, 50 volts
- C<sub>2</sub> = 16 μf, 15 volts
- C<sub>3</sub> = 0.1 μf, 400 volts
- C<sub>4</sub> = 8 μf, 450 volts
- C<sub>5</sub>, C<sub>12</sub> = 0.02 μf, 400 volts
- C<sub>6</sub> = 0.5 μf, 150 volts
- C<sub>7</sub> = 0.5 μf, paper, 150 volts
- C<sub>N</sub>, C<sub>9</sub> = 0.002 μf, mica
- C<sub>10</sub>, C<sub>11</sub> = 8 μf, 250 volts
- C<sub>13</sub>, C<sub>14</sub> = 0.015 μf, 400 volts
- C<sub>15</sub> = 16 μf, 500 volts
- C<sub>17</sub> = 50 μf, 100 volts
- C<sub>18</sub> = 0.0002 μf, mica
- C<sub>19</sub> = 1.0 μf, 750 volts
- R<sub>1</sub>, R<sub>3</sub> = 1-megohm potentiometer
- R<sub>2</sub>, R<sub>4</sub> = 500-ohm potentiometer
- R<sub>5</sub> = 800 ohms, 0.5 watt
- R<sub>6</sub>, R<sub>24</sub>, R<sub>26</sub> = 0.25 megohm, 0.5 watt

- R<sub>7</sub>, R<sub>N</sub> = 50000 ohms, 0.5 watt
- R<sub>8</sub>, R<sub>12</sub>, R<sub>13</sub> = 0.1 megohm, 0.5 watt
- R<sub>10</sub> = 0.5 megohm, 0.5 watt
- R<sub>11</sub> = 1.0 megohm, 1 watt
- R<sub>13</sub> = 0.5 megohm, 1 watt
- R<sub>14</sub> = 4500 ohms, 5 watts
- R<sub>15</sub> = 350 ohms, 0.5 watt
- R<sub>16</sub> = 150 ohms, 0.5 watt
- R<sub>17</sub> = 5000 ohms, 5 watts
- R<sub>18</sub> = 7500 ohms, 5 watts
- R<sub>20</sub> = 0.1-megohm potentiometer
- R<sub>21</sub> = 1500 ohms, 0.5 watt
- R<sub>22</sub>, R<sub>23</sub> = 0.1 megohm, 1 watt
- R<sub>25</sub> = 12000 ohms, 0.5 watt
- R<sub>27</sub> = 15000 ohms, 20 watts
- R<sub>28</sub> = 1500-ohm potentiometer, wire-wound
- R<sub>29</sub> = 780 ohms, 25 watts

- J<sub>1</sub>, J<sub>2</sub>, J<sub>3</sub> = Shielded, closed-circuit jack
- J<sub>4</sub> = Shielded, 3-circuit jack for double-button microphone
- T<sub>1</sub> = Microphone to 500-ohm line transformer
- T<sub>2</sub> = Modulation transformer
- T<sub>3</sub> = 2.5-volt fil. transformer, insulated for 5000 volts
- T<sub>4</sub> = Power transformer
- T<sub>5</sub> = Output transformer; plate-to-plate impedance, 5000 ohms
- L<sub>1</sub> = 12-henry, 120-ma. filter choke; d-c resistance, 80 ohms
- L<sub>2</sub> = 40-henry, 50-ma. filter choke; d-c resistance, 250 ohms (approx.)
- S<sub>1</sub>, S<sub>2</sub> = S.P.D.T. switch
- S<sub>3</sub>, S<sub>4</sub>, S<sub>5</sub> = S.P.S.T. switch

NOTE: The 879 audio rectifier should be built into the modulator unit in order to keep high-voltage leads away from the speech amplifier; the modulator and the speech amplifier must have a common ground connection. J<sub>1</sub> and J<sub>3</sub> are high-impedance inputs for a crystal microphone; J<sub>2</sub> is for a 500-ohm line; J<sub>4</sub> is suitable for either a double-button carbon microphone or a low-impedance line (in the latter case, R<sub>28</sub> must be set at ground potential). Voltage gain of amplifier is about 40000 at input to 2A3's; an input of less than 0.002 peak volt will produce full power output. The 97-volt positive bias on the 879 provides satisfactory amc action for plate-modulated class C r-f amplifiers operating with a d-c plate voltage of 500 to 1500 volts. In general, the bias for the 879, developed principally across R<sub>14</sub>, should be about 10 per cent of the d-c plate voltage of the modulated amplifier.

\* L. C. Waller, "Automatic Modulation Control," RADIO, March, 1938; "Negative-Peak Automatic Modulation Control for Plate-Modulated 'Phone Transmitters,'" QST, October, 1937.

# INDEX

	Page		Page
<b>Amplifiers:</b>		triode charts	166, 167, 169
audio-frequency	19	useful formulas table	163
audio mixer	188	Choke, swinging	176
chart of class A	169	Choke-Input Filter	174
chart of class B	164	<b>Circuit Diagrams:</b>	
chart of class C (triodes, tetrodes, and pentodes)	166-168	audio mixer	188
class A	19	automatic modulation-control amplifier	188
class AB	19, 21	break-in operation	185
class B a-f	19, 21	bridge rectifier	173
class B r-f	19, 24	cathode-bias supply	148, 149
class C	19, 25	class A modulator	183
parallel	20, 31	class AB <sub>1</sub> audio amplifier	187
push-pull	20, 31	class B linear r-f amplifier	187
tuning of class C	156	class B modulator	186
variable gain	188	combination bias supply	184
<b>Anodes, materials for and</b>		crystal oscillator	178-180, 185, 186
construction of	8	electron-coupled oscillator	178
<b>Application, of transmitting tubes</b>	19	fixed-bias supply	147
<b>Automatic Modulation-Control</b>		frequency multiplier	179, 180
Circuit	188	full-wave rectifier	173
<b>Bases, materials for</b>	11	grid-leak-bias supply	183
<b>Beam Power Tubes, features of</b>	14	grid-modulated stage	181
<b>Bias:</b>		high-gain a-f amplifier	188
battery, or fixed	147	overload relay	186
cathode, or self	148, 161	parasitic trap	160
considerations in obtaining	147	phase inverter	188
grid-leak	147	plate-modulated pentode	183, 186
<b>Bleeder Resistor</b>	174	plate-modulated tetrode	27, 182
<b>Break-In Operation, circuit for</b>	185	plate-modulated triode	187
<b>Bridge Rectifier Circuit</b>	172, 173	push-pull r-f amplifier	181-183
<b>Bulbs, kind of glass used for</b>	11	r-f filter, for rectifiers	171
		r-f power amplifier	179-187
		rectifier	173, 188
		screen-and-plate modulated amplifier	27, 182, 183, 186
<b>Capacitance Chart,</b>		single-phase rectifier	173, 188
for tuned circuits	151	suppressor-modulated stage	183
<b>Capacitances:</b>		three-phase rectifier	173
in parallel	163	tritron oscillator	185, 186
in series	163	<b>C-L Considerations</b>	149, 163, 175
<b>Capacitive Coupling</b>	153, 156	<b>Condensed-Mercury Temperature</b>	170
<b>Capacitive Reactance</b>	163	<b>Condenser-Input Filter</b>	174, 188
<b>Cathode Bias</b>	148, 161	<b>Coupling:</b>	
<b>Cathode Resistor, calculation of</b>	20, 148	interstage	153
<b>Cathodes:</b>		output	155
materials used for	6	<b>Crystal Oscillators:</b>	
operation of	15	use of	31
types of	6, 15	circuits for	178-180, 185, 186
<b>Charts and Tables:</b>		<b>Current:</b>	
capacitance chart	151	average plate	171
class A amplifier chart	169	cathode	148
class B modulator chart	164	grid	31, 155, 158
class C amplifier chart	166-168	peak plate	170
filter design chart	177	<b>Damping, of parasitics</b>	158
inductance chart	152	<b>Diodes, consideration of</b>	12, 170
pentode charts	168, 169	<b> Doubler Circuits</b>	179, 180
ratings vs frequency table	144	<b> Doublers, frequency</b>	30, 146
rectifier circuits chart	173		
rectifier tube chart	169		
tetrode chart	168		

# INDEX (Continued)

	Page		Page
Drivers:		Interstage Coupling .....	153
a-f .....	23, 164, 165	Keying Considerations .....	30
r-f .....	24, 146	L-C Considerations .....	149, 163, 175
Efficiency, amplifier .....	20-29	Linear Amplifier, class B .....	24, 187
Electron-Coupled Circuit .....	178	Link Coupling .....	153, 184, 187
Emission Efficiency .....	6	Load Impedance .....	146, 156
Excitation, r-f .....	146	Magnetic Overload Relay .....	162, 171
Exciter Stages .....	146, 178-180	Mercury-Vapor Rectifiers:	
Filaments:		condensed-mercury	
operation of .....	15, 16	temperature of .....	170
rating of .....	15, 142	features of .....	12, 170
reactivation of .....	15	initial operation of .....	170
rheostat control of .....	15	interference from .....	171
supply voltage for .....	15, 142	plate-voltage delay period for .....	170
Filters:		r-f filters for .....	171
choke-input .....	174	shielding of .....	171
condenser-input .....	174	stabilizing inductance or resistance	
design curves for .....	177	for parallel operation of .....	174
design of .....	174	Microphone Amplifier .....	188
double-section .....	175	Mixer, audio .....	188
radio-frequency .....	171	Modulation:	
single-section .....	175	amplitude of .....	26
Formulas .....	163	circuits for (see Circuit Diagrams)	
Frequency Multipliers:		high level .....	24
use of .....	30	low level .....	24
circuits for .....	179, 180	methods of .....	19-29
Frequency vs Tube Ratings .....	144	Modulation Factor .....	26
Full-Wave Rectifiers .....	12, 172	Modulation Impedance .....	24
Fuses, use of .....	161, 171	Modulators, chart of class B .....	164
Generic Tube Types .....	12	Multipliers, frequency .....	30, 179, 180
Grid Bias .....	20-29, 147	Neutralization .....	154
Grid Current .....	31, 155, 158	Ohm's Law (d-c) .....	163
Grid Excitation .....	146	Oscillator:	
Grid Modulation .....	28, 181	crystal .....	31
Grid Neutralization .....	154	electron-coupled .....	178
Grids, materials for .....	10	Output Coupling .....	155
Harmonic Generator Circuit .....	180	Output Power .....	143
Harmonic Output .....	150	Overload Relays .....	162
Heater:		Parallel Operation of Tubes .....	20, 31, 174
potential difference between		Parallel Resonance .....	163
cathode and .....	16	Parasitic Oscillations .....	158
supply voltage for .....	15, 142	Peak Inverse Voltage .....	170
Heater Cathode .....	6, 15	Peak Plate Current .....	170
High-Vacuum Rectifiers .....	12, 170	Pentodes:	
Impedance, plate-circuit load .....	146, 156	charts of .....	168, 169
Inductance and Capacitance		considerations of .....	13
Considerations .....	149, 163, 175	crystal oscillator	
Inductance Chart .....	152	(see Crystal Oscillators)	
Inductive Coupling .....	153, 156	modulation of .....	14, 27, 29
Inductive Reactance .....	163	Phase Inverter Circuit .....	188
Installation, of transmitting tubes .....	15	Phone Transmitters	
Instruments:		(see Radiotelephony)	
protection of .....	161	Plate Current, peak .....	170
use of .....	16, 18, 155	Plate Dissipation .....	16
Intermediate Amplifiers .....	146	Plate Load Impedance .....	146, 156

## INDEX (Continued)

	Page		Page
Plate Modulation .....	26, 27	self-bias .....	148, 161
Plates (see Anodes)		Resonance, formulas for .....	163
Power Output .....	143	Screen:	
Power Sensitivity .....	14	consideration of .....	13
Power Supply:		modulation of .....	27
bleeder resistor for .....	174	series resistor for .....	17, 27
circuits for .....	173	voltage supply for .....	17, 25, 27, 29, 30
filament .....	15, 142	Secondary Electrons .....	11, 13
rectifiers for .....	169, 170	Self-Bias .....	148, 161
regulation of .....	172, 176	Sensitivity, power .....	14
ripple voltage of .....	175	Shielding .....	17, 171
Protective Devices .....	161	Side-Band Power .....	26
Protective Resistors .....	18, 157, 161	Sine-Wave Relations .....	163
Push-Pull Crystal Oscillator Circuit	179	Speech Amplifier Circuit .....	188
Push-Pull Operation .....	20, 31	Suppressor:	
Push-Pull R-F Amplifier Circuits		consideration of .....	14
(see Circuit Diagrams)		modulation of .....	29, 183
Q, definition and operating value of	150	Swinging Choke .....	176
Radjotelephony:		Tables and Charts	
amplitude and power relations in	26	(see Charts and Tables)	
automatic modulation control		Tank Circuit:	
circuit for .....	188	design considerations for .....	18, 149
grid modulation in .....	28	impedance of .....	156
modulation and modulation		wiring of .....	18
methods in .....	20-29	Tapped Circuits .....	153, 159, 160
modulator circuits for		Temperature, condensed-mercury	170
.....	181, 183, 186, 187	Tetrodes:	
plate modulation in .....	26, 27	chart of .....	168
speech amplifier circuit for .....	188	considerations of .....	13
suppressor modulation in .....	29	modulation of .....	27
Ratings, of transmitting tubes	141	Transformers:	
Reactance, capacitive and inductive	163	class B .....	23, 24
Rectifiers:		turns ratio for .....	23, 24, 163
chart of .....	169	Transmission-Line Coupling .....	153
circuits for .....	172, 173, 178	Transmitter Design Considerations	145
considerations of .....	12, 170	Transmitting-Tube Application .....	19
filter systems for .....	174	Transmitting-Tube Installation .....	15
full-wave and half-wave .....	12	Transmitting-Tube Ratings .....	141
high-vacuum .....	12, 170	Triodes:	
interference from mercury-vapor	171	charts of .....	164-167, 169
mercury-vapor .....	12, 170	considerations of .....	12
parallel operation of .....	174	crystal oscillator .....	31
protective devices for .....	171	modulation of .....	26
relations in circuits for .....	173	Tritet Oscillator .....	185, 186
Regulation, voltage .....	172	Tube Types, choice of .....	145
Relay, d-c overload .....	162	Tuning an R-F Amplifier .....	156
Resistances:		Ultra-High-Frequency Tubes	
in parallel .....	163	(Included in table) .....	144
in series .....	163	Vacuum Tubes, general	
Resistor:		considerations of .....	6
bleeder .....	174	Voltage, peak inverse .....	170
cathode .....	148, 161	Voltage Amplifiers, class A .....	19, 169
current-limiting, for		Voltage Regulation .....	172
rectifier tubes .....	174	Voltage Supply .....	15-18, 20-29, 170
filament-voltage control .....	15	Wavelength-Frequency Formula .....	163
grid-leak .....	147		
protective .....	18, 157, 161		
screen .....	17, 27		



# READING LIST

The following list of references includes material of both elementary and advanced character. The list is not inclusive, but it will guide the reader to other references.

## Periodicals

1. *Communications*. Bryan Davis Publishing Co., Inc., New York.
2. FYLER, G. W. *Parasites and Instability in Radio Transmitters*. Proc. I.R.E., September, 1935.
3. NERGAARD, L. S. *Electrical Measurements at Wavelengths Less Than Two Meters*. Proc. I.R.E., Vol. 24, September, 1936.
4. *Proceedings of the Institute of Radio Engineers*. The Institute of Radio Engineers, New York.
5. QST. The American Radio Relay League, West Hartford, Conn.
6. *Radio*. Radio, Ltd., Los Angeles, California.
7. SPITZER, E. E. *Grid Losses in Power Amplifiers*. Proc. I.R.E., pp. 985-1005, June, 1929.
8. SPITZER, E. E. *Anode Materials for High-Vacuum Tubes*. Electrical Engineering, November, 1935.
9. WAGENER, W. G. *Simplified Methods for Computing Performance of Transmitting Tubes*. Proc. I.R.E., Vol. 25, January, 1937.

## Books

10. DUNCAN AND DREW. *Radio Telegraphy and Telephony*. John Wiley and Sons, Inc., New York.
11. EVERITT, W. L. *Communication Engineering*. McGraw-Hill Book Co., Inc., New York.
12. HENNEY, KEITH. *Radio Engineering Handbook*. Mc-Graw-Hill Book Co., Inc., New York.
13. HUND, AUGUST. *High Frequency Measurements*. McGraw-Hill Book Co., Inc., New York.
14. *Jones Radio Handbook* (now "Radio" Handbook). Radio, Ltd., Los Angeles, Cal.
15. MORECROFT, J. H. *Elements of Radio Communication*. John Wiley and Sons, Inc., New York.
16. NILSON, A. R. AND HORNING, J. L. *Practical Radio Communication*. McGraw-Hill Book Co., Inc., New York.
17. "Radio" *Antenna Handbook*. Radio, Ltd., Los Angeles, California.
18. *RCA Receiving Tube Manual (RC-13)*. RCA Manufacturing Co., Inc., Harrison, N. J.
19. *RCA Cathode-Ray Tubes and Allied Types (TS-2)*. RCA Manufacturing Co., Inc., Harrison, N. J.
20. RIDER, JOHN F. *The Cathode-Ray Tube at Work*. John F. Rider, Publisher, New York.
21. TERMAN, F. E. *Radio Engineering*. Mc-Graw-Hill Book Co., Inc., New York.
22. TERMAN, F. E. *Measurements in Radio Engineering*. McGraw-Hill Book Co., Inc., New York.
23. *The Radio Amateurs' Handbook*. The American Radio Relay League, West Hartford, Connecticut.



# TRANSMITTING TUBES

NOTED FOR

PERFORMANCE

RELIABILITY

ECONOMY

RECOMMENDED AND DISTRIBUTED BY