

8-3-71

73

Dipole and Long-Wire Antennas

by Edward M. Noll,

W3FQJ

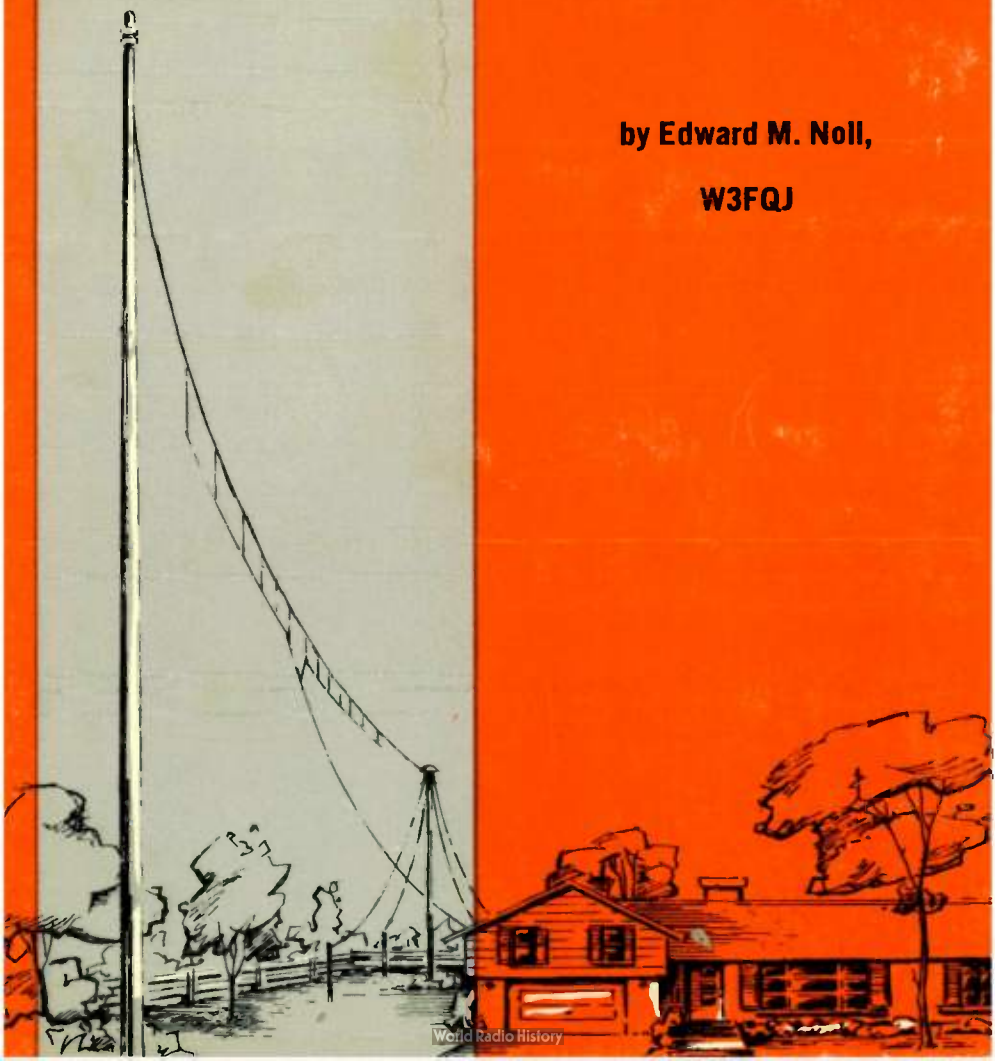

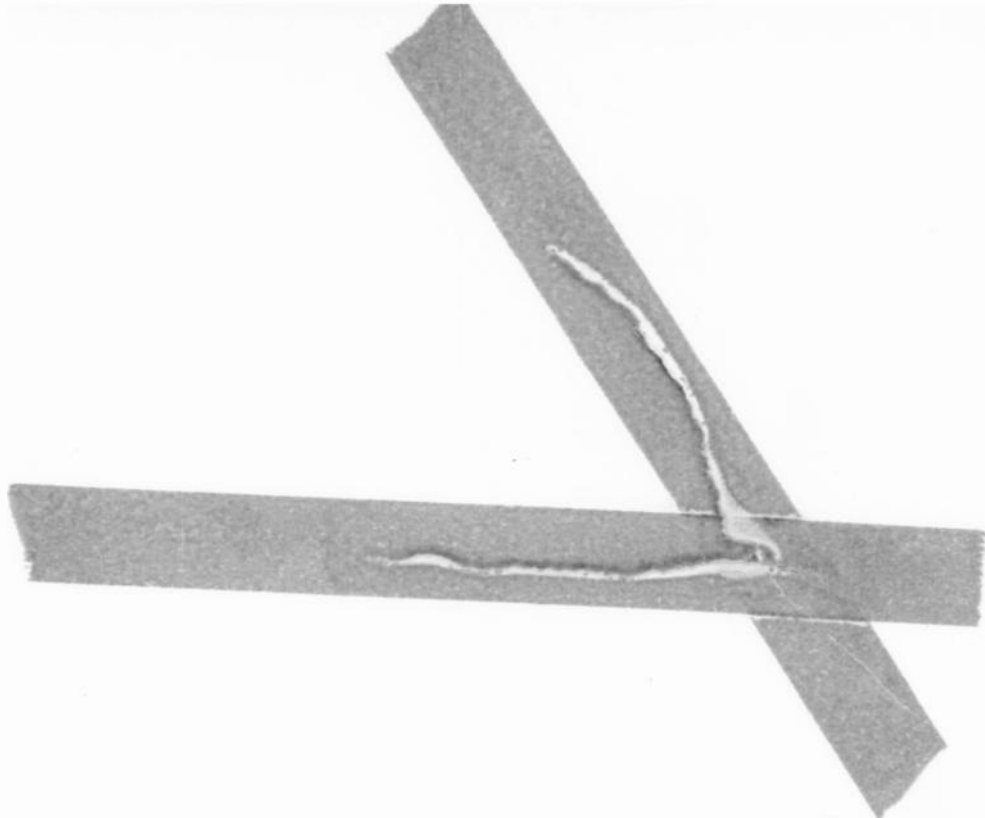

73

DIPOLE and LONG-WIRE ANTENNAS

by Edward M. Noll,

W3FQJ

Antenna experimentation offers a unique opportunity to make amateur radio hobby more than a operational spectator activity. All you need are telescoping masts, antenna wire, insulators, ingenuity, and a desire to experiment.

Antenna types from dipole to rhombic are covered in this book, and the topics are arranged in a sequential manner—from simple constructions to more and more complex ones. However, if the reader is interested in just one type of antenna, he can go directly to that type.

The necessary mathematics are included, but no extensive knowledge is required to build the antennas described. Simple test instruments are shown which will enable the reader to optimize the designs and obtain maximum performance from his antenna.

Many of these antennas compete with, and some surpass the performance of commercial beams. The serious experimenter will find in **73 Dipole and Long-Wire Antennas** examples of almost every type of wire antenna, included for the first time under one cover.



ABOUT THE AUTHOR

In addition to being an accomplished author of technical books, lessons, articles, and instruction manuals, Ed Noll is also a consulting engineer and lecturer. His other books include:

First-Class Radiotelephone License Handbook

Second-Class Radiotelephone License Handbook

Radar License Endorsement Handbook

Radio Operators License Handbook

all published by
Howard W. Sams & Co., Inc.

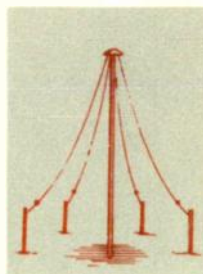

EDITORS AND ENGINEERS, LTD.
New Augusta, Indiana

65071

\$4.50 (In Canada \$5.40)

73 Dipole and Long-Wire Antennas

by Edward M. Noll, W3FQJ

EDITORS and ENGINEERS, LTD.
New Augusta, Indiana

FIRST EDITION

FIRST PRINTING—1969

Copyright © 1969 by Editors and Engineers, Ltd., New Augusta, Indiana. Printed in the United States of America.

All rights reserved. Reproduction or use, without express permission, of editorial or pictorial content, in any manner, is prohibited. No patent liability is assumed with respect to the use of the information contained herein.

Library of Congress Catalog Card Number: 72-81301

Preface

An often-heard comment of the present is: "The days of amateurs building and operating their own equipment are a thing of the past." To a great extent this is true, since the advent of sophisticated single-sideband equipment has convinced many hams that construction of their own gear is no longer practical.

The one big exception to this approach to amateur radio is in the field of antennas. The amateur, at very little expense and without the requirement of an R and D laboratory, can indulge in experimentation and building antennas—sometimes with startling results.

73 Dipole and Long-Wire Antennas is the first of a series of books which can make the hobby of amateur radio more than an operational spectator activity. Each antenna described in this book was constructed by the author, without assistance, and a minimum of tools and equipment was used. You can do the same, and use the world as your testing ground.

Many of the antennas described in this book compete with, and sometimes surpass, the performance of commercial beams. A number of new approaches in the construction of the basic long-wire antenna types are detailed.

There are 73 individual antennas included in an order that begins with simple construction and progresses in a sequential manner to more complex arrangements. However, if you are interested in only one particular type, you can locate that type immediately, and find that each type is completely described.

73 Dipole and Long-Wire Antennas is an invitation to some inexpensive education and fun. You will find it very educational and satisfying to put up a cheap antenna that you have calculated, erected, and tuned. You also gain a fringe benefit—that in talking to amateur friends all over the world, you can describe your antenna setup and really know what you are talking about.

EDWARD M. NOLL, W3FQJ

Contents

SECTION 1. REGULAR AND MODIFIED DIPOLE ANTENNAS

1. Half-Wavelength Dipole	9
2. Dipole Antenna, Line Tuned	11
3. Dipole and Balun	14
4. Novice-Band Dipoles	15
5. Advanced and Extra-Class Band Dipoles	16
6. Lamp-Cord Dipoles	16
7. Twin-Lead Folded Dipole	18
8. Folded Dipole and Balun	18
9. Inverted Dipole	19
10. Novice 15-40 Dipoles	21
11. Novice 15-80 Dipoles	23
12. Novice 40-80 Dipoles	23
13. Novice 15-40-80 Dipoles	24
14. 20-40-80 Maypole	26
15. 20-40-80 C-W Special	28
16. One-Wavelength Antenna	28
17. 3/2-Wavelength Antenna	30
18. Low-Band Segmented Dipoles, 40-80-160	33
19. Middle-Band Segmented Dipoles, 20-40-80	34
20. Open-Wire Two-Band Dipole	35
21. Extra and Advanced Open-Wire Inverted Dipoles	37

SECTION 2. INVERTED-VEE ANTENNAS

22. Center-Fed Monoband Inverted Long-Wire Vees	41
23. Two-Band Inverted Long-Wire Vees—No Tuning	43
24. Two-Band Inverted Vee—End Tuned	44
25. Long-Wire Inverted Vee—Sideband 10-15-20	46
26. All-Band 6-160 Inverted Vee	47
27. 15-40 Novice Inverted Vee	49
28. 15-40-80 Novice Inverted Vee	50

29. 10-15-20 and 20-40-80 Inverted-Vee Trio	52
30. W3FQJ Inverted-Vee 6-Through-80 Sidebander	52
31. Long-Wire Inverted Vees With Line Tuner	55

SECTION 3. LONG-WIRE ANTENNAS

32. Single Long-Wire Resonant Antennas—Center Fed	59
33. Single End-Fed Monoband Long-Wire Resonant Antennas	61
34. 10-15-20-40 Long-Wire WAS Special	63
35. Single Random Wire With Line Tuner	65
36. Resonant Antenna Plus Random-Wire Loading	66

SECTION 4. VEE-BEAM ANTENNAS

37. End-Fed Monoband Inverted-Vee Beam	71
38. 10-, 15-, and 20-Meter Inverted-Vee Beam	73
39. Four-Band Inverted-Vee Beam With Tuner	75
40. Three-Halves Wavelength Horizontal Vee	76
41. 15-40 Three-Halves-Wavelength Vee	78
42. 15-40 Conical Three-Halves-Wavelength Vee	79
43. 15-40 Conical Vee With Balun	80
44. Short Horizontal Vee-Beam Antenna	81
45. Duo-Band Horizontal Short Vee Beams	82
46. Tilted Short Vee Beams	83
47. 10-15-20 Short Vee Beam	84
48. 10-15-20-40 One-Hundred Footer	85
49. 10-15-20-40 Short Vee Beam	87
50. 10-15-20-40-80 Vee Beam and Inverted Dipole	88

SECTION 5. LONG VEE-BEAM ANTENNAS

51. Long Horizontal Vee-Beam Antenna	93
52. Long Horizontal Vee-Beam Antenna, Two Bander	96
53. 10-15-20 Vee Beam With Line Tuner	98
54. Multiband Vee-Beam Antenna With Antenna Tuner	98
55. Sloping Vee Beam	100
56. 10-15-20 Sloping Vee Beam	101

SECTION 6. RHOMBIC ANTENNAS

57. 10-15 Rhombic Antenna	107
58. 10-15-20 Rhombic With Line Tuner	111
59. 10-15-20-40 End-Tuned Rhombic	113
60. Two-Wire 10-15-20 Rhombic	114
61. Resonant Rhombic With Tuner and Open-Wire Line	115
62. Terminated Rhombic	116

SECTION 7. VERY LONG LONG-WIRE ANTENNAS

63. Two-Band Very Long Long-Wire Antenna	121
64. End-Tuned Very Long 5 DXCC Long Wire	123
65. 5 DXCC Long-Wire Special	125
66. All-Band 6-160 End-Fed Very Long Wire With Tuner	126
67. Long-Path Short-Path Long-Wire Antenna	128

SECTION 8. SPECIAL VEES AND RHOMBICS

68. 160-Meter Two-Mast Inverted Vee	131
69. 10-160 End-Tuned Two-Mast Inverted Vee	132
70. Two-Mast Vee Beam	133
71. Three- and Four-Mast Switchable Vee Beams	134
72. Two-Mast Rhombic	137
73. Short Squared Rhombic	138

APPENDIX I

Antenna Noise Bridge	143
----------------------------	-----

APPENDIX II

How to Measure the Velocity Factor of Transmission Line With a Noise Bridge	145
--	-----

APPENDIX III

Cutting Half-Wave Sections of Transmission Line Using the Antenna Noise Bridge	147
---	-----

APPENDIX IV

Measuring the Resonant Frequency and Resistance of an Antenna With the Antenna Noise Bridge	149
--	-----

APPENDIX V

Cutting an Antenna to Resonance Using an SWR Meter	152
--	-----

APPENDIX VI

The Construction and Tuning of a Line Tuner	154
---	-----

APPENDIX VII

Antenna Tuner for Long-Wire Vees and Rhombics	159
---	-----

SECTION 1

**Regular and Modified
Dipole Antennas**

1 — Half-Wavelength Dipole

As a starting point for the antennas discussed in this book, the half-wavelength dipole is considered to be the shortest long-wire antenna. Other long-wire types stem from this fundamental antenna dimension. In a dipole arrangement the transmission line is attached at the center (Fig. 1), and there is a quarter-wavelength conductor on each side of the feed point.

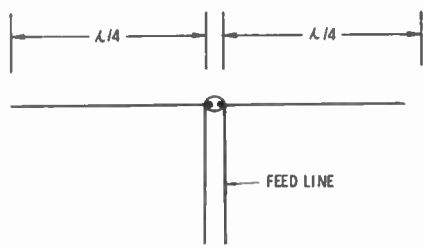

Fig. 1. Half-wavelength dipole antenna.

In free space and at most practical antenna heights the feed-point impedance is approximately 72 ohms. This can vary as a function of antenna height and the proximity of other conducting material.

The physical length of a dipole antenna is shorter than the calculated half wavelength of its resonant frequency. Thus the physical length of a dipole must be made shorter than the calculated free-space wavelength that corresponds to its resonant frequency. NOTE

A half wavelength ($\lambda/2$) in space has the following length: NOTE

$$\lambda/2 = \frac{492}{f \text{ MHz}}$$

The physical length of the dipole antenna needed to establish a resonant length for frequency (f) is shorter than this value

NOTE by approximately 5 per cent. A practical equation for calculating the length of a half-wavelength dipole is:

$$\lambda/2 = \frac{468}{f \text{ MHz}}$$

NOTE This length is influenced some by conductor dimensions, height above ground, and nearby conducting objects.

The directional pattern of a dipole antenna is a figure 8 with maximum radiation and sensitivity broadside to the antenna wire (Fig. 2). The vertical radiation pattern for a horizontal antenna

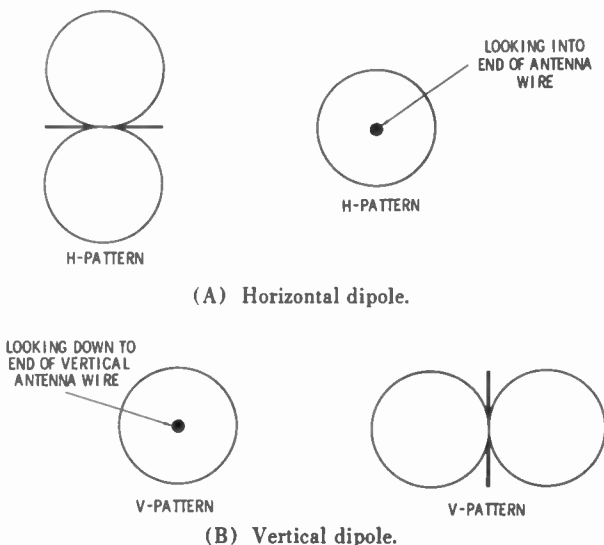

Fig. 2. Free-space dipole radiation patterns.

is circular. For a vertical dipole, the horizontal pattern is circular, while the vertical pattern in free space is a figure 8. In a practical situation the vertical pattern is modified by the influence of ground.

When a dipole antenna is fed with a 72-ohm line and the transmitter output loading circuit can be tuned to an output impedance of 72 ohms, the entire system is matched, and there is efficient transfer of power to the antenna. The standing wave on the transmission line is minimum and there is minimum attenuation of the signal by the line. In this case the matching is unaffected by the overall length of the line. Of course, losses increase with line length as a function of line attenuation figures. Under

matched conditions and a good-quality line those losses can be quite insignificant for surprisingly long lengths of transmission line.

Chart 1 presents dipole antenna dimensions for the radio amateur bands from 10 meters through 160 meters related to the center of each band, center of the phone segment, and center of the c-w segment.

The antennas described in this book were constructed variously of numbers 12, 14, and 16 wire, bare and insulated, with no significant differences in performance. In fact, insulated #14 was used extensively. Insulated wire provides an additional safety factor, can be run through trees, and is convenient for multi-conductor antenna applications.

Chart 1. Dipole and Half-Wavelength Line Dimensions

Band in Meters	Band Center			C-W Band			Phone Band		
	Ant.	0.66 Line	0.81 Line	Ant.	0.66 Line	0.81 Line	Ant.	0.66 Line	0.81 Line
160	256'5"	178'1"	218'1"	256'5"	178'1"	218'1"	256'5"	178'1"	218'1"
80	124'10"	86'8"	106'2"	128'3"	89'	109'	120'	83'4"	104'9"
40	65'5"	45'5"	55'8"	65'11"	45'9"	56'1"	64'7"	44'10"	54'9"
20	33'	22'11"	28'1"	33'2"	23'1"	28'3"	32'9"	22'9"	27'11"
15	22'	15'4"	18'9"	22'1"	15'4"	18'10"	21'11"	15'3"	18'8"
10	16'3"	11'3"	13'10"	16'7"	11'6"	14'1"	16'1"	11'2"	13'8"



2 — Dipole Antenna, Line Tuned

A dipole antenna at resonance does not always present exactly 72 ohms impedance to the transmission line. Also the antenna impedance off of the resonant frequency is other than 72 ohms. Antenna height above ground and the presence of nearby conducting obstacles influence the antenna resistance too.

Transmission-line impedances other than 72 ohms are employed. Fifty-ohm coaxial lines are popular and there are a variety of accessories designed for 50-ohm operation. Although the mismatch of 72 ohms to 50 ohms is not great, such a mismatch plus other factors that influence antenna resistance can cause a significant standing-wave ratio on the line. Poor ratios should be avoided because many transmitters, especially modern transceivers, are quite critical as to loading.

A proper match at the transmitter end of the line is important for two reasons—proper loading of the transmitter, and efficient operation of the antenna system. A 50-ohm line can be used with a dipole antenna and quite often performs well; however, it is advisable to stay away from reactive loading of the transmitter

if at all possible. This can be accomplished by cutting the length of the transmission line to an electrical half wavelength or a multiple of one-half wavelength (Fig. 3). In cutting an electrical

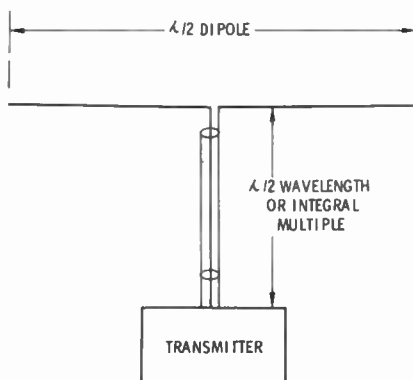

Fig. 3. Line-tuned half-wavelength antenna.

half wavelength of line, it is necessary to consider the velocity factor of the line:

$$\text{Line length } (\lambda/2) \text{ in feet} = \frac{492 \times VF}{f \text{ MHz}}$$

Of course, the length of the transmission line can be any integral multiple of the above length.

Chart 2 is based on the velocity factors of 0.66 and 0.81 typical of 50-ohm and 72-ohm regular and foam-dielectric type coaxial lines respectively. This information can be used to determine the dimensions of a length of line that will best accommodate the separation between the transmitter and the antenna feed point. For example, if you plan to operate a dipole on 7.1 MHz, and the approximate distance between antenna and transmitter is 100 feet, it is wise to use a length of transmission line of approximately 91 or 137 feet corresponding to either 2 or 3 half wavelengths of regular RG/58U or RG/59U line:

$$\text{Line length} = \frac{650}{7.1} = 91.55 \text{ ft.}$$

$$\text{Line length} = \frac{975}{7.1} = 137.3 \text{ ft.}$$

Chart 1 gives half-wavelength line lengths of 0.66 and 0.81 velocity factors for the various amateur bands.

A very precise cut cannot always be made by calculation alone for the reason that velocity factors are not always exactly the stated values of 0.66 or 0.81 because of line discontinuities and other variables. The exact velocity factor can be obtained by measurement, or a line can be cut for a half-wavelength condition on some precise frequency. Techniques and procedures are given in Appendices I through V.

For multiband operation, compromise line lengths are used. In most cases a length can be found which provides a reasonable match on each band. Examples will be given for many of the multiband antennas in this book.

A good compromise length for 40-, 20-, 15-, and 10-meter operation, using VF-0.66 line, is a whole multiple of 45' 6". If 80-, 40-, 20-, 15-, and 10-meter operation is desired, use a whole multiple of 90'. When VF-0.81 line is used, a whole multiple of 56' provides good performance on 10 through 40 meters. Make it a whole multiple of 112' to include 80 meters.

An alternative plan is to employ a line tuner (Fig. 4). Such a tuner can accommodate a random length of line although it is still advisable to cut the line close to one of the half-wavelength

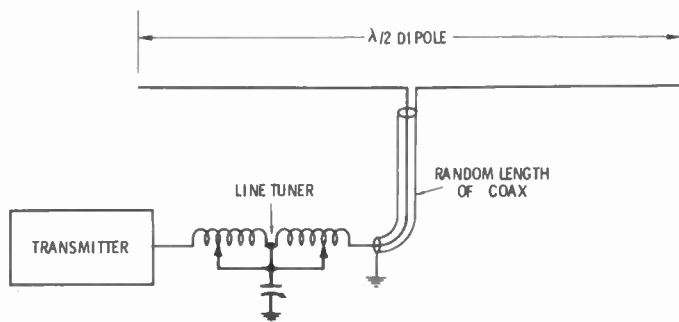

Fig. 4. Use of line tuner.

figures. An added advantage of the line tuner is that it can be used to tune the line over an entire amateur band or a group of bands by using tapped inductors and variable capacitors. Such a tuner can be adjusted to present the proper resistive load to the transmitter, and it tunes out reasonable reactive components so that they are not reflected to the transmitter.

**Chart 2. Dimensions of Half-Wavelength Line Segments
for Velocity Factors of 0.66 and 0.81**

Line Segments in Wavelengths	(VF=0.66) Line Lengths in Feet Reg. RG/58U-RG/59U	(VF=0.81) Line Lengths in Feet of Foam RG/58U-RG/59U
1/2	325/f	400/f
2/2	650/f	800/f
3/2	975/f	1200/f
4/2	1300/f	1600/f
5/2	1625/f	2000/f
6/2	1950/f	2400/f
7/2	2275/f	2800/f
8/2	2600/f	3200/f
9/2	2925/f	3600/f
10/2	3250/f	4000/f
11/2	3575/f	4400/f
12/2	3900/f	4800/f
13/2	4225/f	5200/f
14/2	4550/f	5600/f
15/2	4875/f	6000/f
16/2	5200/f	6400/f

3 — Dipole and Balun

A dipole antenna presents a resistive 72-ohm load only at its resonant frequency. The idealized value of 72 ohms can be affected by surroundings. At points off the resonant frequency, there are also reactive components present. Nevertheless, the performance of the antenna system can be optimized using the procedure covered in topic 2.

The dipole antenna is a *balanced* antenna system with identical and equal-length elements on each side of the feed point. Conversely, the commonly used coaxial transmission line constitutes an *unbalanced* feed system. Thus there are unequal r-f currents in the quarter-wavelength dipole sections which can disturb the radiation pattern and produce unfavorable line conditions which result in line radiation (Fig. 5).

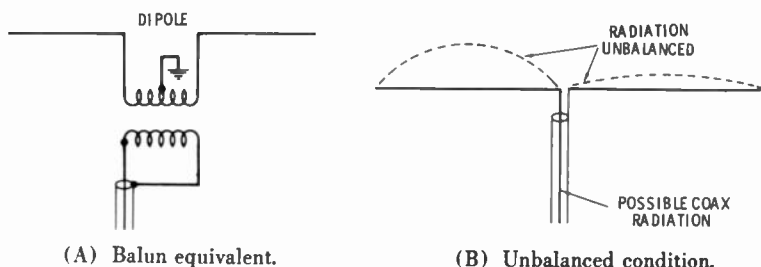

Fig. 5. Plan of a balun and condition which it reduces.

A balun avoids these imbalances by serving as a balance-to-unbalance transformer (Fig. 6). As such, it provides an efficient transformation between the single-ended coaxial line and the balanced dipole antenna. In matching a dipole to a coaxial line the

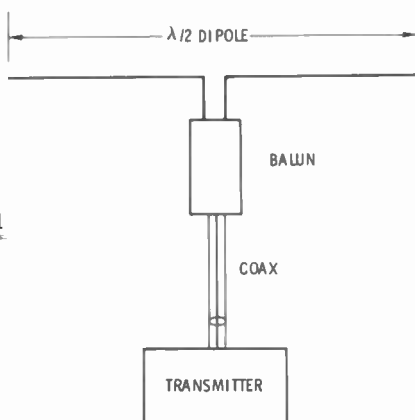

Fig. 6. Dipole antenna with 1 to 1 balun.

preferred balun transformation is one-to-one. Baluns of four-to-one and other ratios are feasible for matching higher antenna resistances to a 50- or 72-ohm coaxial cable.

A balun ensures more favorable line conditions and less disturbance of the antenna radiation pattern, and helps in establishing a more favorable standing-wave ratio over a wider span of frequencies, as compared to the dipole-direct-to-coaxial-line method of connection.

4 — Novice-Band Dipoles

Dipoles can be cut for optimum operation on the 80-, 40-, and 15-meter novice bands. Dimensions for novice-band centers are given in Chart 3. Optimum coaxial line lengths for half-wave segments of coaxial line are also given. Line lengths which are

Chart 3. Novice-Band Dipole and Line Dimensions

Novice-Band Centers	$\lambda/2$ Dipole Length	$\lambda/2$ Line Length- 0.66 Regular Coax	$\lambda/2$ Line Length- 0.81 Foam-Dielectric Coax
3.725 MHz	125'8"	87'3"	103'11"
7.175 MHz	65'3"	45'3"	55'6"
21.175 MHz	22'2"	15'4"	18'9"

integral multiples of these stated values may also be used. Refer to topics 1 and 2.

5 — Advanced- and Extra-Class Band Dipoles

Some amateurs concentrate their operations within the advanced- or extra-class bands. Dipoles can be cut with optimum performance on these portions of the spectrum. Dimensions as centered on the advanced and extra portions of the frequency spectra are given in Chart 4. Line lengths for optimum performance are also suggested. Line lengths which are multiples of the values given also provide optimum results. Refer to topics 1 and 2.

Chart 4. Advanced and Extra-Band Dipole and Line Dimensions

ADVANCED			
MHz Band	Center	$\lambda/2$ Dipole	$\lambda/2$ Line 0.66 VF
3.825—3.9	3.8625	121'2"	84'2"
7.2 —7.25	7.225	64'8"	45'
14.2 —14.275	14.2375	32'10"	22'10"
21.275—21.350	21.3125	21'11"	15'3"
EXTRA			
MHz Band	Center	$\lambda/2$ Dipole	$\lambda/2$ Line 0.66 VF
3.5 — 3.55	3.525	132'9"	92'2"
3.8 — 3.825	3.8125	122'9"	85'3"
7.0 — 7.05	7.025	66'7"	46'3"
14.00—14.05	14.025	33'4"	23'2"
21.00—21.05	21.025	22'3"	15'6"
21.25—21.275	21.2625	22'	15'3"

6 — Lamp-Cord Dipoles

Common electrical lamp cord can be used to construct indoor, portable, or emergency dipoles. The lamp cord can be divided down the middle, setting off two dipoles of appropriate length (Fig. 7). The remainder of the lamp cord then serves as the transmission line between antenna and transmitter. Antenna resistance of the dipole is 72 ohms and the characteristic impedance of the lamp cord is usually not too much different from this value. To aid in matching, the line segment is made a multiple of a half-wavelength long.

Fig. 7. Lamp-cord dipole.

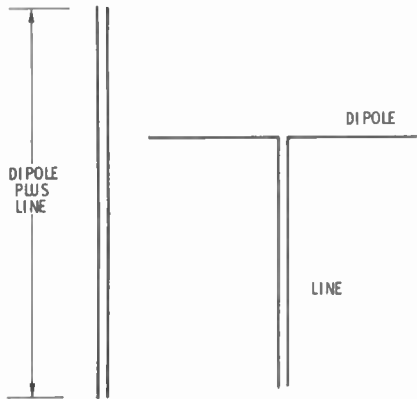

In constructing such an antenna use a section of lamp cord which has a total length corresponding to the dipole *plus* the transmission line. Then it can be cut down the middle to form the dipoles. Electrical tape can be used to secure the point of separation (Fig. 8). The insulation need not be bared from the dipole because it does not hamper the radiation of the r-f energy. The ends of the dipole can be fed through the eyes of the insulators and secured with electrical tape.

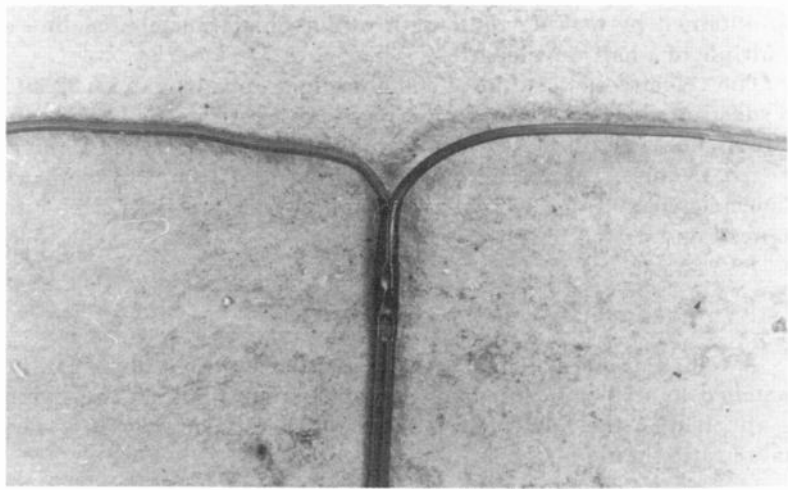

Fig. 8. Taping of lamp-cord dipole.

Such an antenna is serviceable for attic mounting. Since it is very flexible and consists of few components, it can be packed and stored conveniently, and serves well for quick portable installations.

7 — Twin-Lead Folded Dipole

An inexpensive and popular form of quick antenna construction has been the twin-lead folded dipole (Fig. 9). A folded dipole has a feed-point impedance of approximately 300 ohms rather than 70 ohms. Consequently it matches the characteristic impedance of the twin line from which it is made.

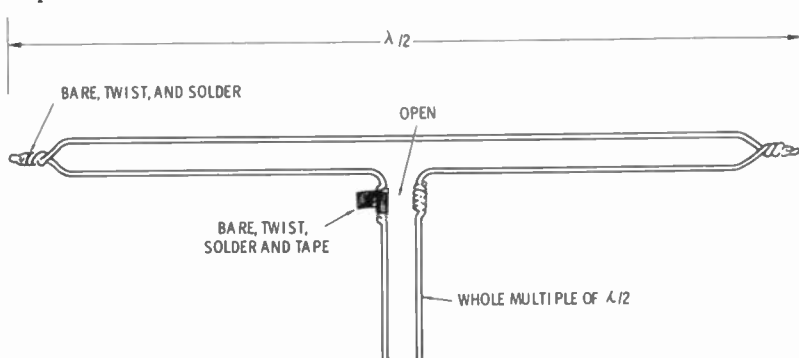

Fig. 9. Twin-lead folded dipole.

Some transmitters have enough output tuning range to provide a suitable match to a 300-ohm system. Again, matching help can be obtained by making the length of 300-ohm transmission line a multiple of a half wavelength.

The velocity factor of most 300-ohm lines approximates 0.82 and is substituted in determining the physical length needed to obtain a total line length that is a multiple of an electrical half wavelength. Values approximate those given in Chart 2 for foam-dielectric coaxial line which has a velocity factor of 0.81. Refer to topics 1 and 2.

8 — Folded Dipole and Balun

A folded-dipole antenna with its resistance of 300 ohms can be matched to a 50-ohm unbalanced system using a balun. The balun is attached to the feed point of the folded dipole (Fig. 10). The balun ratio should be 4 to 1.

One of the commercially available wideband types can be used or one can be constructed from a section of 72-ohm coaxial transmission line as shown in Fig. 10B. Don't forget to consider the velocity factor in cutting the line that is employed in the balun.

An alternate plan is to position the balun near the transmitter. This is a more economical arrangement when there is a great



(A) Balun at the antenna.

(B) Balun constructed of coax.

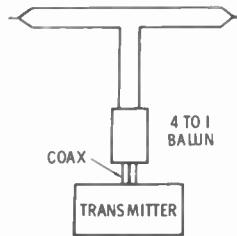

(C) Balun placed near transmitter.

Fig. 10. Baluns and connection arrangements.

separation between folded dipole and transmitter. Of course, one must be more careful in laying out the 300-ohm feed line so that it does not come too close to conducting surfaces. Stand-off insulators must be used to hold 300-ohm line away from the mast, while in a well-balanced and matched system, one can tape coaxial line to a mast.

It is a good idea to make the span of 300-ohm line between the antenna and balun a multiple of a half wavelength. The balun can be positioned within a few feet of the transmitter, or at any convenient point—perhaps the position at which the line is to enter the house. Refer to topics 1, 2, 3, and 7.

9 — Inverted Dipole

The inverted dipole has been and is a popular antenna because of its good results, ease of erection, durability, low cost, and limited space requirement. The inverted dipole is, in effect, a conventional horizontal dipole with its ends tilted down toward the ground (Fig. 11). The angle between the two legs is usually between 90 and 120 degrees, depending on apex height and leg length.

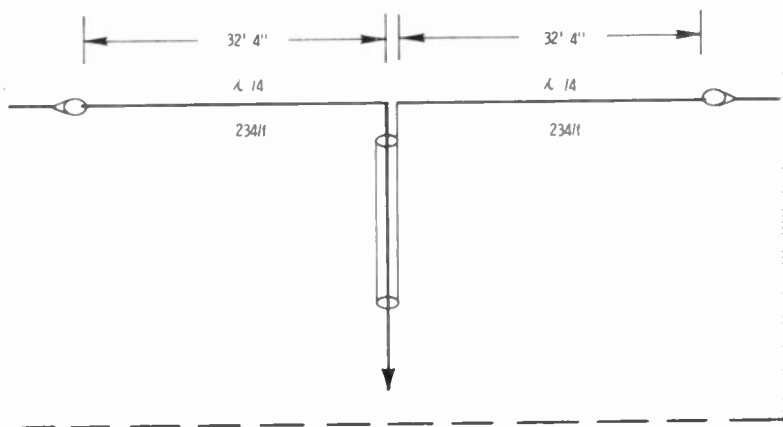

(A) Horizontal dipole.

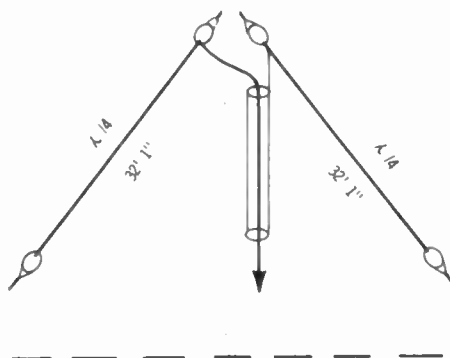

(B) Inverted dipole.

Fig. 11. Dimensions for 40-meter phone operation.

The leg length for a given resonant frequency is somewhat shorter than that of a straight horizontal dipole. As a function of apex angle and nearness of the leg ends to ground, the shortening falls between 2 and 6 percent. The nearer the antenna ends are brought to ground, the shorter is the leg length for a given resonant frequency. An antenna bridge or SWR meter is helpful in trimming the antenna to frequency. The work can be done conveniently with the antenna erected, because the leg ends are accessible from ground. Refer to Appendices I through IV.

Antenna feed-point impedance drops away from the impedance value of a horizontal dipole, becoming lower as the angle between the two wires is decreased. Usually a better match is made to

50- rather than 72-ohm line. Again, the most favorable conditions exist when the transmission line is made a multiple of a half wavelength at the operating frequency.

The performance of the inverted dipole is in general more uniform than the performance of a straight dipole. The horizontal pattern is less directive. Gain is less by comparison to the broadside gain of a horizontal dipole of the same height, because the inverted dipole has its antenna legs tilted down toward ground. However, the performance of the inverted dipole, relative to other horizontal angles, equals or betters that of the straight dipole. Another advantage of the inverted dipole is its lower angle of radiation and more vertical polarization. Thus for long-distance communications especially on 7 MHz and higher, surprising results are obtained with the inverted dipole.

Only a single erection mast or high mounting position for the apex is needed. The inverted dipole ends can be brought very near to the ground and can be tied down to metal fence posts, the side of a garage, shed, etc. Dimensions for a 40-meter phone inverted dipole are given. Optimum transmission-line length is a whole multiple of 45' 6". Refer to topics 1 and 2.

10 — Novice 15-40 Dipoles

More than one dipole can be attached to the same center feed point. If done properly, there can be minimum interaction and good operation on more than one band. For optimum results the two dipoles should be separated as much as possible from each other. It is best to have the elements of one dipole perpendicular to those of the other, rather than parallel (Fig. 12A). Thus, in erecting a 15- and 40-meter combination, the 15-meter wires should run broadside to the 40-meter wires. A further reduction in the interaction between the two dipoles can be obtained by using different polarization. In fact, a good-performing combination would be a 40-meter dipole and a 15-meter inverted vee (Fig. 12B). This combination has the 15-meter wires perpendicular to the 40-meter wires, and the 15-meter polarization has been changed away from that of the 40-meter dipole.

It has been said that the ordinary 40-meter dipole operates as a three-halves wavelength antenna on 15 meters. It is true that a 40-meter antenna often loads on 15 meters, but seldom can performance and standing-wave conditions on the transmission line be made as good as those obtainable when using a separate 15-meter dipole. The two frequency bands are not related properly for this optimum condition. In fact, a dipole cut for the low end

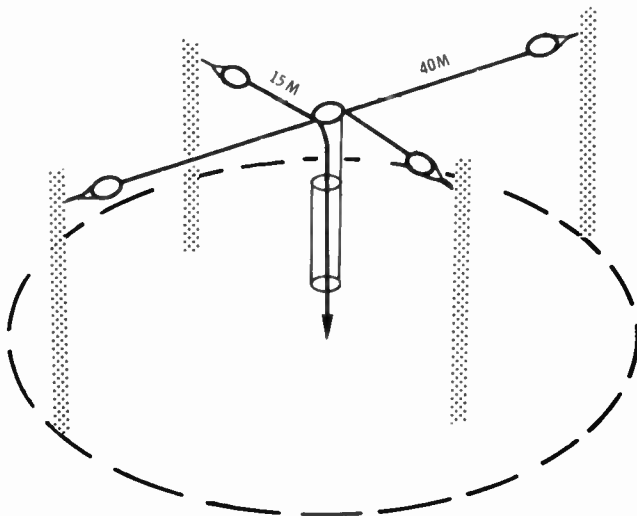

(A) Horizontal-dipole placement.

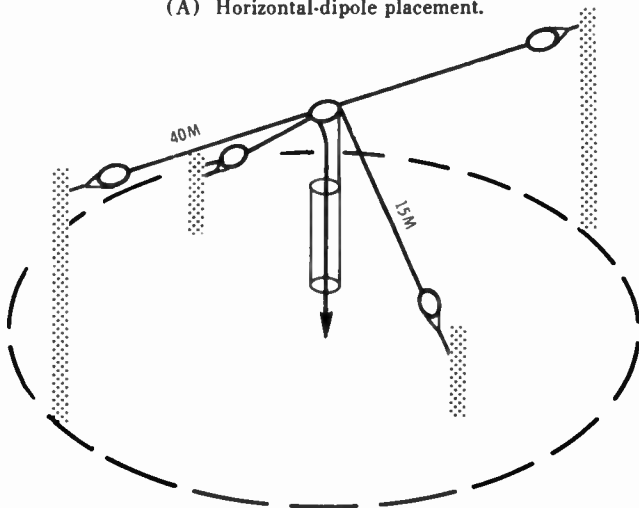

(B) Horizontal 40-meter dipole and inverted 15-meter dipole at center.

Fig. 12. 15- and 40-meter dipoles connected to same feed point.

of the 40-meter band is still too short for three-quarter wavelength operation at the high end of the 15-meter band. This is because end effect is a consideration in choosing the length of the 40-meter dipole, while it is less influential in determining the overall length of a three-halves wavelength antenna on 15 meters.

The inverted-dipole combination of Fig. 13 is a good combination. Only a single mast is required and the advantages of low-

angle radiation can be obtained on both bands. The 15-meter dipole wires should be at right angles to the 40-meter segments. Refer to topics 1, 2, 4, and 9.

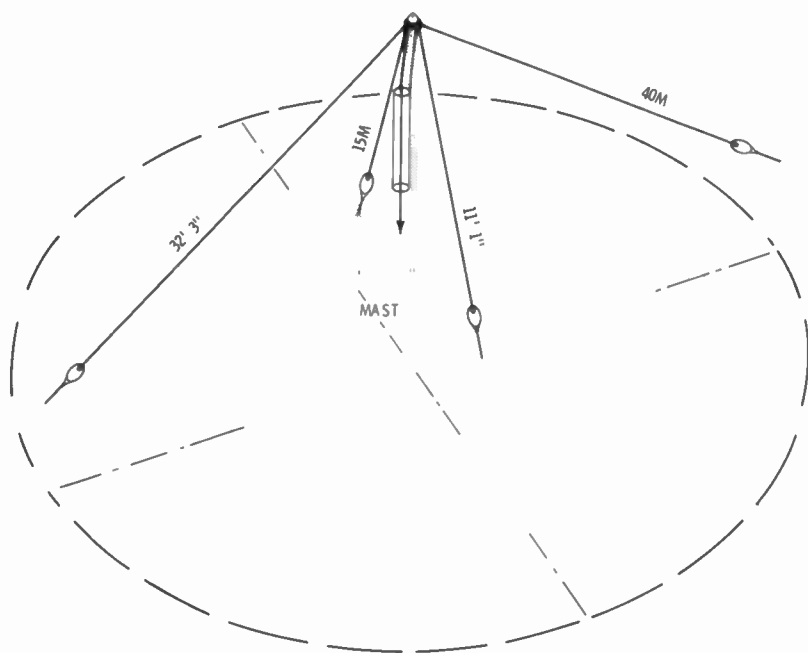

Fig. 13. 15-40 meter inverted dipoles.

11 — Novice 15-80 Dipoles

Just about optimum dipole operation can be obtained on 15 and 80 meters using two separate dipoles attached to the same center feed point (Fig. 14). There are three possible arrangements that give good performance. Both dipoles can be mounted horizontally and at right angles to each other; both can be mounted in an inverted-dipole combination; or the 80-meter antenna can be erected as a horizontal dipole, with the 15-meter elements coming off its center feed point as an inverted dipole. Refer to topics 1, 2, 4, 9, and 10.

12 — Novice 40-80 Dipoles

Near optimum operation can be obtained on 40 and 80 meters using two separate dipoles connected to the same center feed

point. There are three arrangements that perform well (Fig. 14). The 40- and 80-meter dipole elements can both be mounted horizontally but at right angles to each other; both can be connected as inverted-vee dipoles; or, if the 80-meter dipole can be mounted

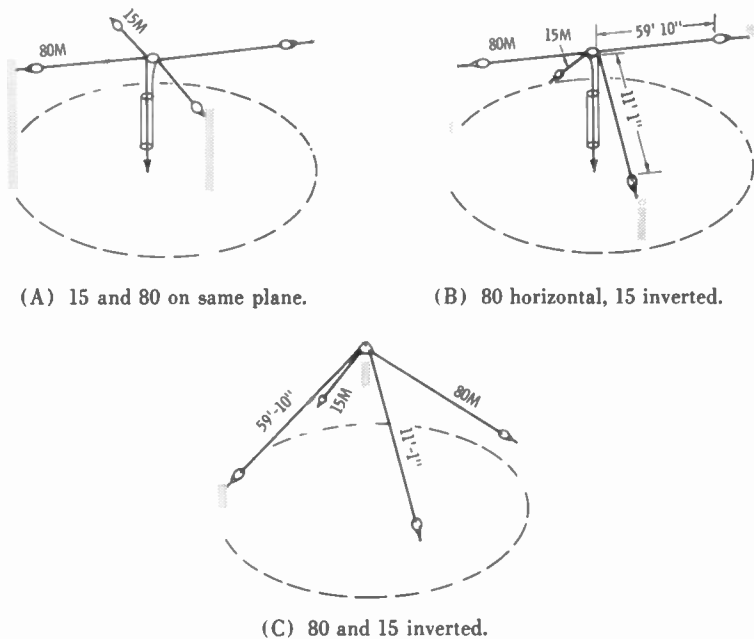

Fig. 14. 15-80 meter dipole combinations.

high enough, it is possible to run the 40-meter antenna wires off the center point as an inverted dipole. Forty- and 80-meter inverted dipole leg lengths are 32' 3" and 59' 10" respectively. Straight dipole dimensions are given in Chart 4. Refer to topics 1, 2, 4, 9, and 10.

13 — Novice 15-40-80 Dipoles

Three-band operation for the novice can be obtained by using three separate dipoles connected to the same center feed point. The secret of multi-dipole operation is to keep the various antennas isolated from each other as much as possible. Stay away from parallel runs of the antenna wires.

Two favorable arrangements are shown in Fig. 15. In example A the dipoles are mounted horizontally and are 60 degrees related in their physical positions. A simple and good performing arrange-

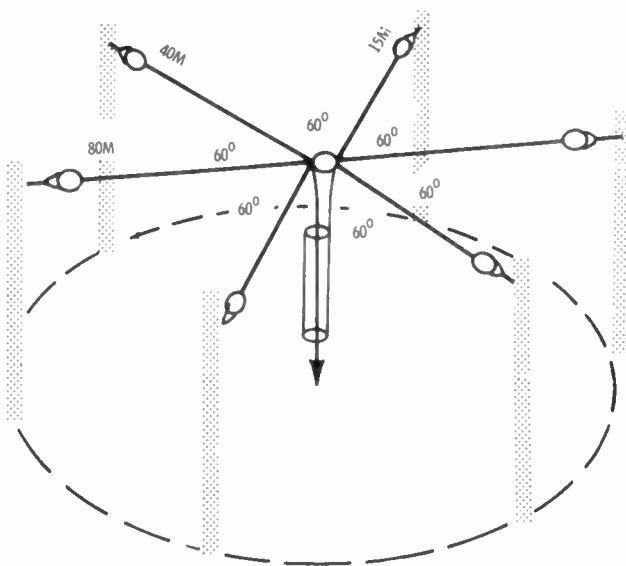

(A) Horizontal dipoles.

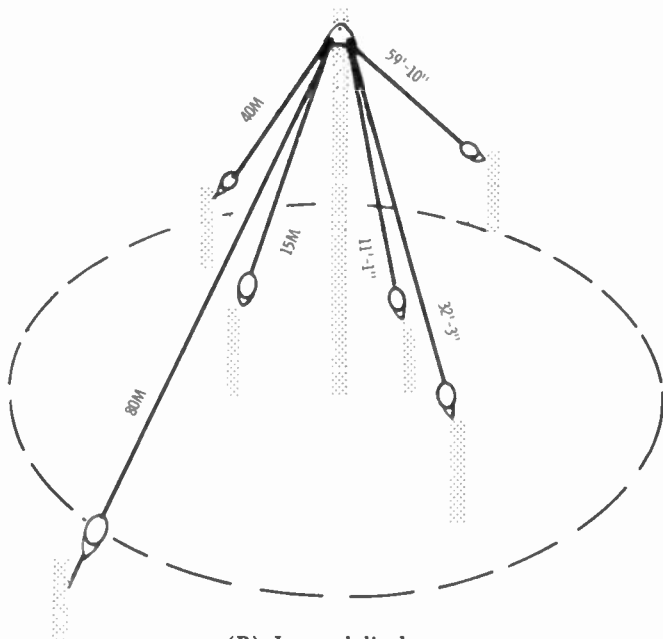

(B) Inverted dipoles.

Fig. 15. Novice 15-40-80 dipoles with common feed point.

ment using a single mast is the maypole arrangement of three inverted dipoles as shown in Figs. 15B and 16. The individual dipoles are 60 degrees related to each other in terms of their horizontal positioning around the mast. Refer to topics 1, 2, 4, 9, and 10.

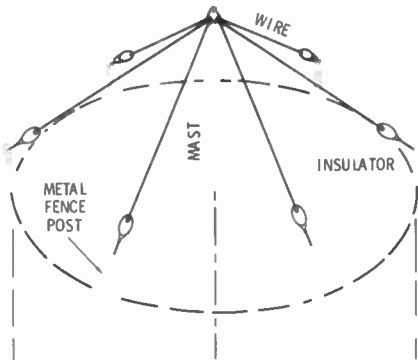

(A) Side view.

Fig. 16. Inverted-vee multi-antenna construction.

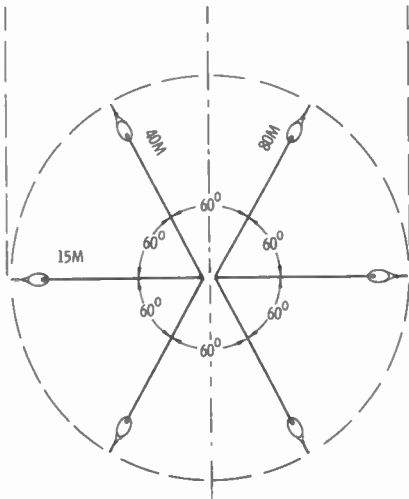

(B) Top view.

14 — 20-40-80 Maypole

Many radio amateurs confine their operations to 20, 40, and 80 meters. Some transmitters and transceivers function only on

these bands. A single antenna that permits rapid band changeover is a desirable attribute for these operators. If done properly three separate dipoles can be attached to the same center feed point and made to give optimum dipole operation on each of the three bands. The secret of good performance and low standing-wave ratios is to keep the dipoles isolated from each other as much as possible except at the feed point. The inverted-dipole style and its single supporting mast (Fig. 17) provides a good-performing arrangement in a small mounting area. The three dipoles are 60-degree related relative to their physical positioning around the mast. This affords a higher order of isolation.

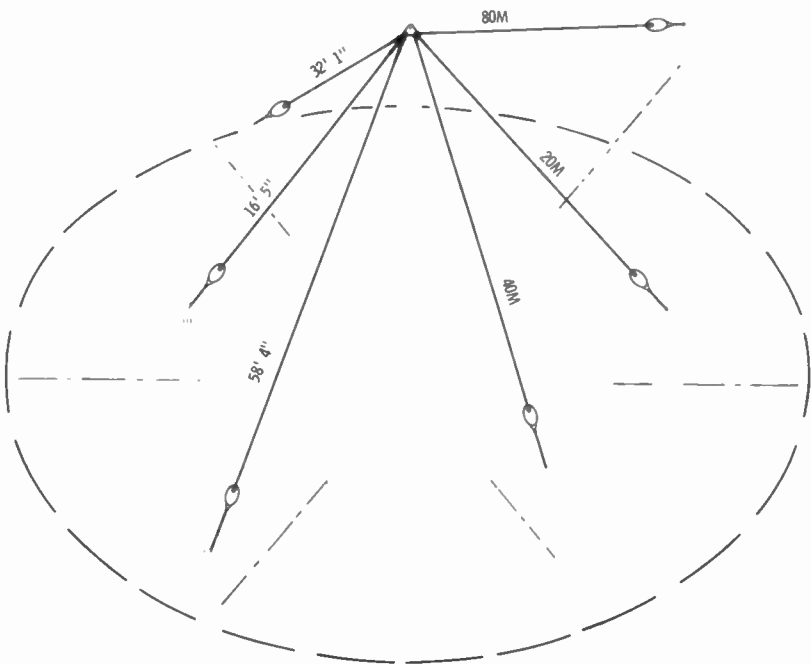

Fig. 17. 20-40-80 phone inverted dipoles.

Furthermore, the 80-meter wires stretch out more nearly horizontal while the 20-meter wires can be made the most vertical. Thus, there is some additional isolation through differing polarization, and at the same time, the more favored lower angle of vertical radiation can be obtained with increasing frequency.

Dimensions for a 20-40-80 phone antenna are given. Dipole ends are brought near the ground level and antenna resonance can be

shifted at will toward the low end of any band by clipping on additional short sections of antenna wire to the dipole ends (Fig. 18). Refer to topics 1, 2, 9, and 13.

15 — 20-40-80 C-W Special Inverted Dipoles

The inverted dipole construction of the previous topic (Fig. 17) is ideal for the c-w ham who concentrates his operations on 20, 40, and 80. The antenna occupies a relatively small space, is low cost, and no changes are needed when switching bands. The quarter-wave dipole segments when cut to resonate in the special and advanced c-w bands are 63' 4", 33' 1", and 16' 8" for the 80-, 40-, and 20-meter bands respectively.

If you operate both phone and c-w, an ideal arrangement is to use the dimensions for phone operation given in the previous topic. Cut clip-on extensions for attachment when operating cw (Fig. 18). These lengths are 5', 1', and 3" for the 80-, 40- and 20-meter bands respectively. Refer to topics 1, 2, 9, 13, and 14.

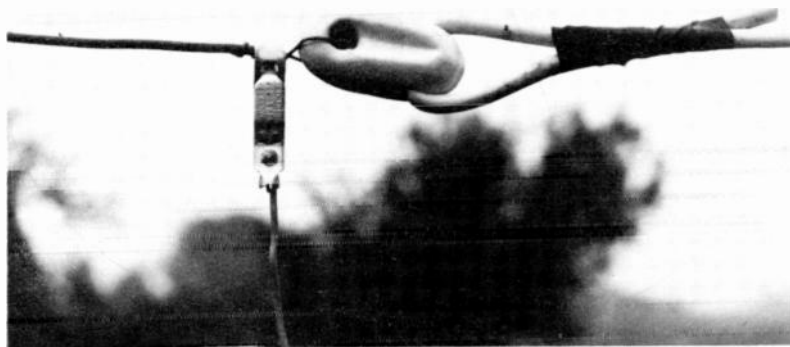
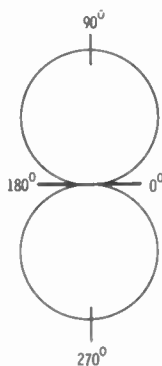
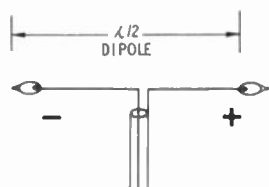

Fig. 18. Clip-on extension to lower resonant frequency of antennas.

16 — One-Wavelength Antenna

A half-wavelength dipole antenna is resonant on a specific frequency. Resonance on the same frequency can also be obtained by doubling the dipole length to form a "long-wire" one-wavelength antenna (Fig. 19). Such an antenna can be fed at the center. However, the center is a maximum-voltage/minimum-cur-

rent, or high-impedance point. Therefore a high-impedance transmission line must be used, or some sort of tuner is necessary to make the transformation from the low-impedance line to the high-impedance feed point.



(A) Half-wave dipole.

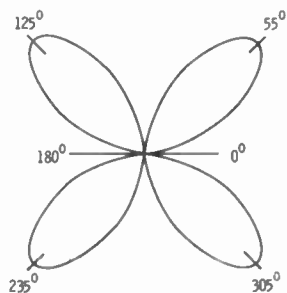
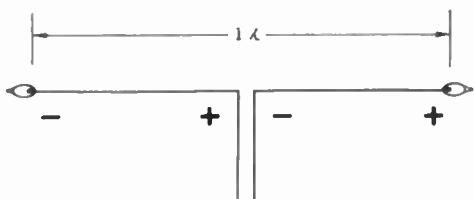

(B) Full-wave dipole.

Fig. 19. Comparisons in length and horizontal pattern of horizontal dipole and one-wavelength antennas.

Often this type of antenna is called two half wavelengths in phase as indicated by the polarities (in Fig. 19). The fields of the two horizontal half-wave segments interact to form a cloverleaf horizontal radiation pattern, instead of the figure-eight of a single half-wavelength dipole antenna (Fig. 19B). Note that radiation maxima occur at 55° , 125° , 235° , and 305° instead of the 90° and 270° of a horizontal dipole. Each of the four lobes of the one-wavelength antenna show a slight improvement in gain over the two-lobe maxima of the dipole. Of course, each lobe has a somewhat narrower beam angle than a dipole lobe.

A practical one-wavelength antenna is shown in Fig. 20. Dimensions are for 15-meter operation. Note that the feed point has been moved away from the center by a quarter wavelength. In so doing, a lower-impedance feed point is found (one quarter wavelength on one side and three quarter wavelengths on the other). There is a suitable match to either 50- or 72-ohm coaxial cable. Antenna feed-point impedance is only slightly higher (80 to 90 ohms) than a conventional dipole.

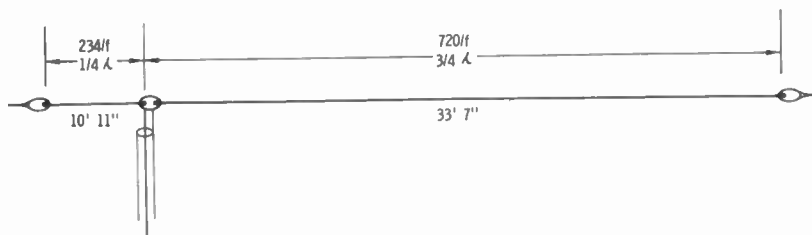

Fig. 20. One-wavelength antenna.

In the erection of the one-wavelength antenna, the direction of the antenna wire should be such that one or more horizontal lobes of the pattern are oriented in preferred directions. For any type of long-wire antenna, it is wise to choose a length of transmission line that corresponds to a whole multiple of an electrical half wavelength. Refer to topics 1 and 2.

17 — 3/2-Wavelength Antenna

Antennas can be resonated to a specific frequency by making their overall electrical length a whole multiple of a half wavelength. There is a rise in gain with each half-wavelength addition. In the case of a horizontal antenna, the antenna becomes more directive with antenna length.

The addition of leg lengths in odd multiples of a half wavelength ensures a low-impedance center feed point because each leg of such an antenna is an odd number of quarter wavelengths long.

For example, the antenna of Fig. 21 is 3/2 wavelength long, and each leg is 3/4 wavelength long, establishing a low-impedance feed point at the center. The directive pattern of a horizontal 3/2-wavelength antenna is shown in B. Note that two additional lobes have been added as compared to the one-wavelength antenna of Fig. 19.

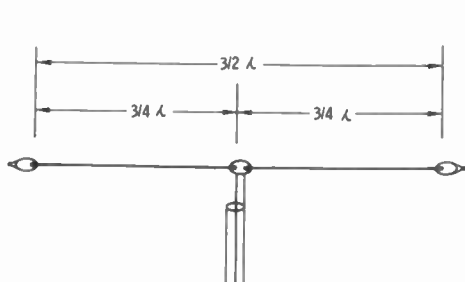

(A) Basic construction.

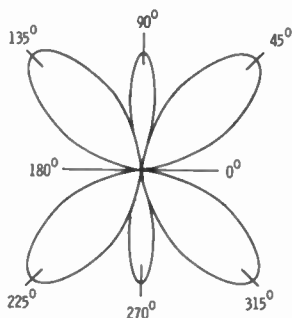

(B) Radiation pattern.

Fig. 21. 3/2-wavelength horizontal antenna and horizontal pattern.

Chart 5 provides the necessary constants for calculating leg lengths that are an odd multiple of a quarter-wavelength long. The constant for a quarter wavelength (half-wavelength dipole) is corrected for end effect. End effect has a decreasing influence with an increase in the number of quarter wavelengths on a leg.

There is some shortening required. It is wise to cut the antenna lengths slightly long in accordance with the constants given. One can then trim back to establish the desired resonant lengths. Refer to Appendices I through V.

Chart 5. Leg Lengths in Quarter Wavelengths and Feet

Leg Length in Wavelengths	Leg Length in Feet (f in MHz)
1/4	234/f
3/4	738/f
5/4	1230/f
7/4	1722/f
9/4	2214/f
11/4	2706/f
13/4	3198/f
15/4	3690/f
17/4	4182/f
19/4	4674/f
21/4	5166/f
23/4	5658/f
25/4	6150/f
27/4	6642/f
29/4	7134/f
31/4	7626/f
33/4	8118/f
35/4	8610/f
37/4	9102/f
39/4	9594/f
41/4	10086/f

Two practical $3/2$ -wavelength antennas are shown in Fig. 22. They have been cut for the 15-meter phone band. When an antenna is made an odd multiple of a half wavelength long, it can be fed either at the center or near one end. End-feed does influence the directivity pattern as compared to the center feed. The change is such that the lobes are of greater magnitude (more gain) on the five-quarter-wave side of the feed point as compared to the one-quarter-wave side.

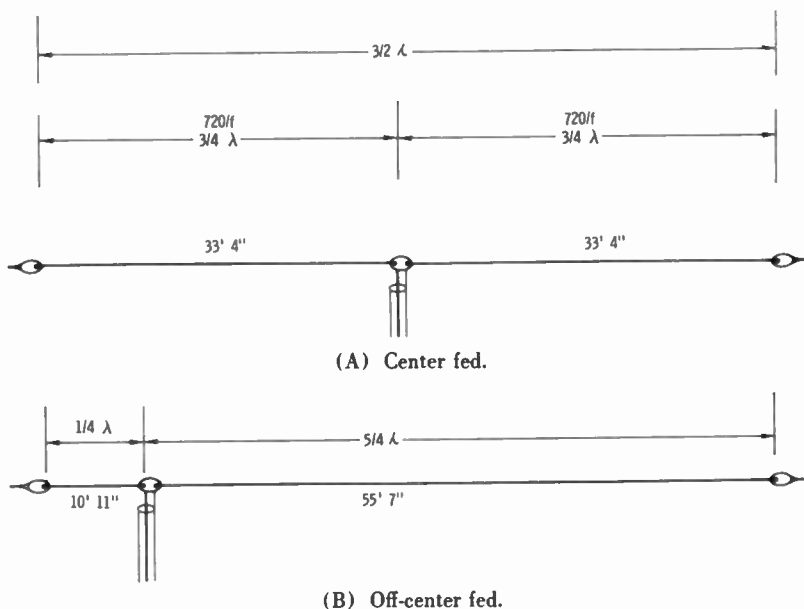

Fig. 22. $3/2$ -wavelength antenna.

Antenna resistance rises to near 100 ohms. Again this is a theoretical free-space value. The practical value depends on height above ground and other surrounding conducting surfaces. It is this indefinite value for most antennas that makes the use of transmission line which is a whole multiple of an electrical half-wavelength a useful practice.

The horizontal lobes of a long-wire antenna can be oriented in favored directions by choosing a favored angle for running the antenna wire. Approximate angles for the $3/2$ wavelength antenna are 45° , 90° , 135° , 225° , 270° , 315° . The 90 -degree and 270 -degree lobes are weaker and narrower than the four cloverleaf lobes. If the antenna wire were run 20 - 200 degrees in the eastern U.S., there would be favorable lobes at 65° , 155° , 245° , and 335° . As

shown in Fig. 23 these would be favorable directions for Europe, North Africa, South America, Australia and New Zealand, and Japan and the Far East respectively. The two minor lobes would be in the directions of the western states and South Africa. Mount the antenna 0.5 to 1.0 wavelength above ground for good low-angle vertical radiation.

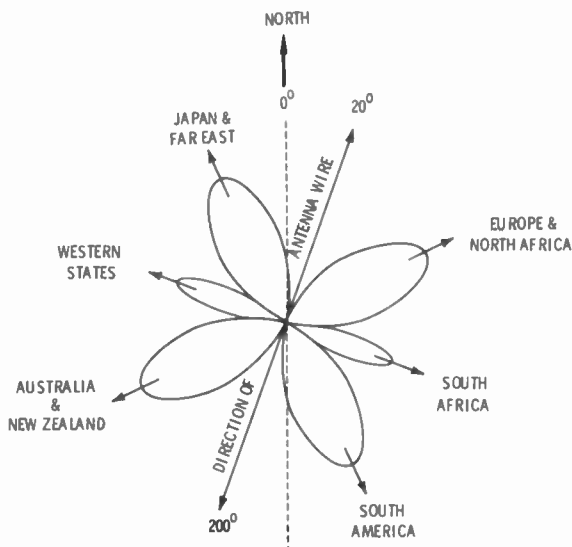

Fig. 23. Orientation of antenna in favored directions.

End-feeding on the 20-degree side favors the 155-degree and 245-degree lobes while end-feeding on the 200-degree side would favor the 65- and 335-degree lobes. Refer to topics 1, 2, and 16.

18 — Low-Band Segmented Dipoles, 40-80-160

Three separate dipoles for 40, 80, and 160 require considerable space, antenna wire, and transmission line. As a result few stations have optimum antenna systems for operation on the three low bands. Such operation can be provided with a single antenna if space is available for 160-meter dipole erection. A single antenna and a single transmission line can provide three-band facilities.

The segmented arrangement with insulators and jumpers is shown in Fig. 24. A simple halyard arrangement at one end can let the antenna down to make the necessary jumper connects or disconnects when operation on another band is desired. The dimensions shown permit operation as a dipole on 80 or 160 meters and operation as a 3/2-wavelength antenna (three-quarter wavelength legs) on 40 meters. Preferred transmission-line lengths

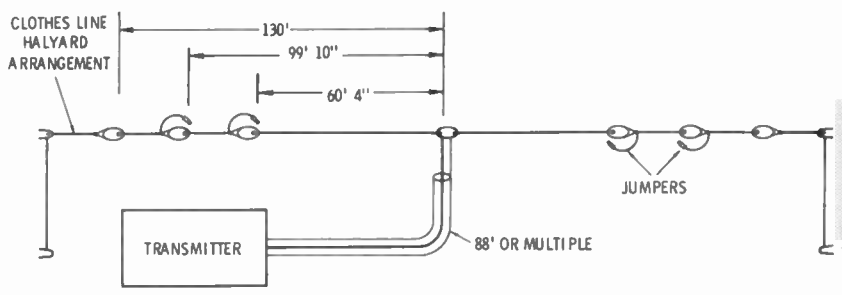
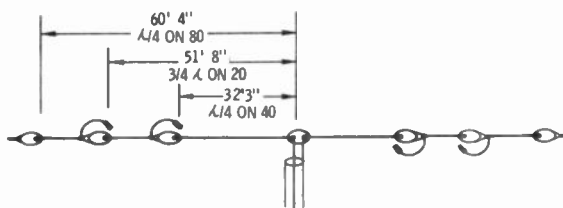

Fig. 24. Low-bands segmented dipoles—40, 80, and 160 phone.

would be 176 feet or an integral multiple. Although a 160-meter dipole is used, transmission-line lengths of 88 feet (or a multiple) can be used if the 160-meter dipole is cut and resonated rather carefully for the portion of the 160-meter band in which operation is desired. Refer to topics 1, 2, and 17.

19 — Middle-Band Segmented Dipoles, 20-40-80

A single antenna and transmission line can provide optimum dipole operation on these three bands using the segmented construction of Fig. 25. The one selected depends on available space. Again insulators, jumpers, and a halyard arrangement provide easy band changeover.



(A) Overall length is used for 80.

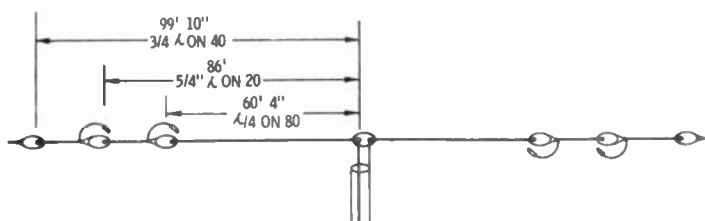

(B) Arrangement if more space is available.

Fig. 25. Segmented dipoles for 20, 40, and 80.

In arrangement A the overall length accommodates 80-meter dipole operation. The antenna is also segmented to provide 40-meter dipole operation. On 20 meters the antenna operates as a three-halves wavelength (three-quarter wavelength legs).

If additional space is available, antenna B can be operated as a dipole on 80 meters, a 3/2-wavelength long wire on 40, and a 5/2-wavelength antenna on 20.

Careful consideration of the direction of the antenna wire can help you align the lobes in preferred DX directions. Refer to topics 1, 2, 17, and 18.

20 — Open-Wire Two-Band Dipole

Open-wire transmission line, suitably cut, can be used to construct two-band antennas. The 450-ohm type is preferable because of the greater separation between conductors.

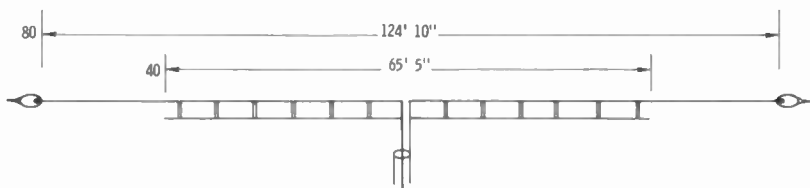

(A) 80-40 combination.

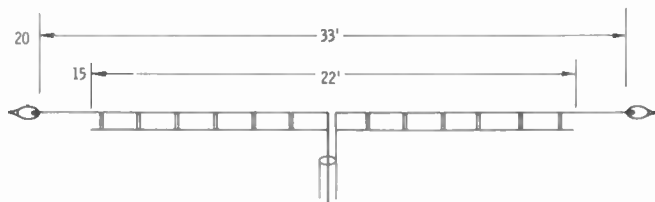

(B) 20-15 combination.

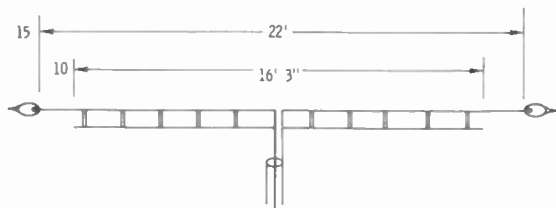

(C) 15-10 combination.

Fig. 26. Open-wire two-band dipoles, band-center dimensions.

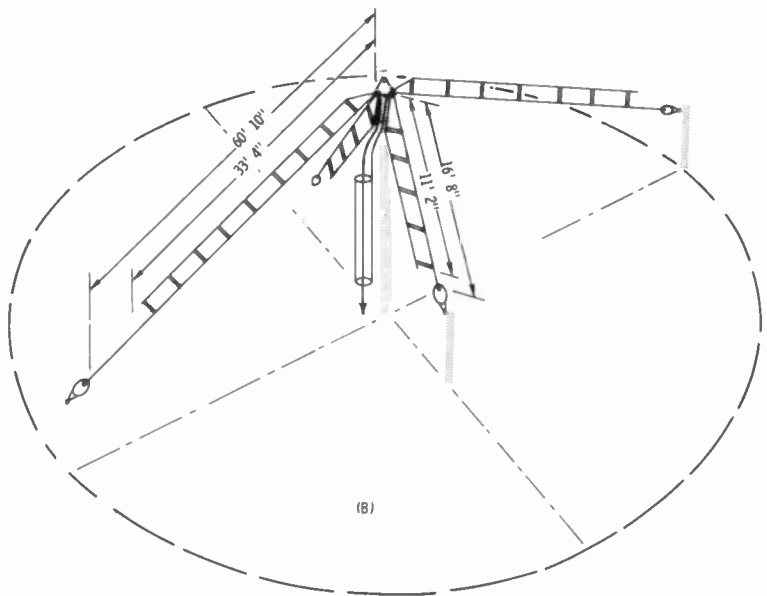
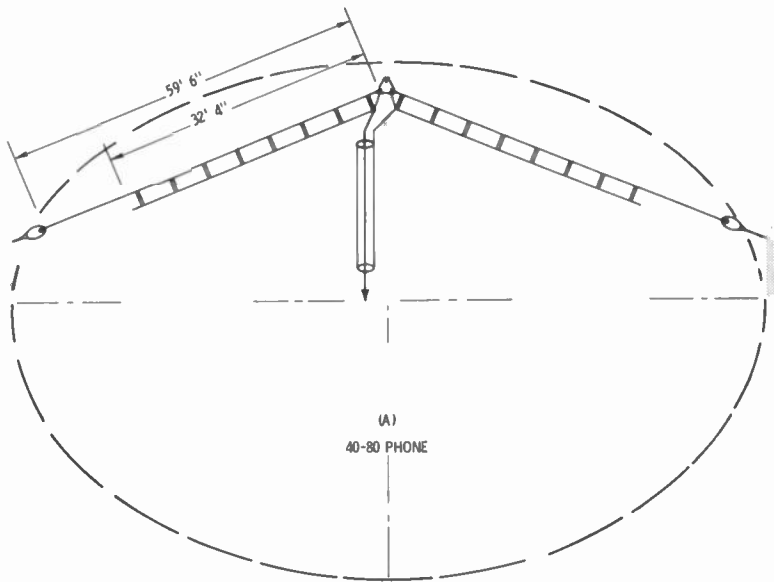

Fig. 27. Inverted dipoles (A) and four-band 15-20-40-80 dipole pairs (B).

The 40-80 combination has long been a popular duo. The longer wire serves as a half-wavelength dipole on 80; the shorter one, serves as a dipole on 40. Other pairs and appropriate dimensions are given in Fig. 26. The dipoles can be cut to a favored section of each band. It is preferable to use a length of transmission line which is a multiple of an electrical half wavelength. Refer to topics 1 and 2.

21 — Extra and Advanced Open-Wire Inverted Dipoles

Open-wire line can be used in the construction of two-band inverted dipoles (Fig. 27A). Various dipole pairs, as discussed in topic 20, can be constructed. Dipole lengths are shorter than formula values as a function of apex height and nearness of the antenna end to ground. Practical dimensions for 80- and 40-meter phone band operation are given.

Two such open-wire inverted dipoles mounted perpendicular to each other function well as a four-band antenna (Fig. 27B). The dimensions given in B are for c-w operation in the extra and advanced portions of the 15-, 20-, 40-, and 80-meter bands. Individual antennas can of course be cut for a specific portion of any one of the bands. Refer to topics 1, 2, 9, 13, 14, and 20.

SECTION 2

Inverted-Vee Antennas

22 — Center-Fed Monoband Inverted Long-Wire Vees

All antennas require a support structure and transmission line. This expense is a part of each antenna system. To this must be added the cost of the antenna proper. If it is made of antenna wire and assorted insulators, it amounts to a low-cost antenna. Such is the case for the long-wire inverted vee's. Another economy of this construction is that only a single mast or high point of erection is needed.

The inverted-vee construction is also less directional than the horizontal dipole or straight long-wire antenna. As the legs become more vertical, the horizontal radiation pattern becomes less directional. There is a loss in gain, too, as compared to the sensitive direction of the horizontal long wire. However, even this is overcome to some extent, especially for high-band operation and long-distance communications, because of its lower vertical angles of radiation.

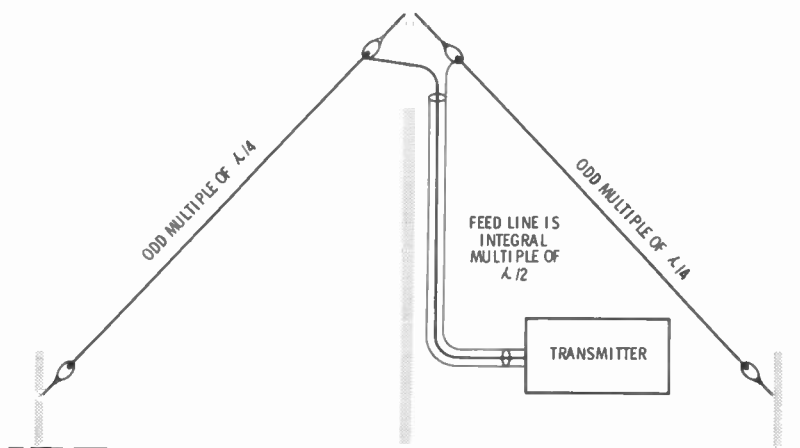

Fig. 28. Basic plan of a resonant and matched long-wire inverted vee.

The matching problems related to the long-wire inverted vee can also be minimized by choosing leg lengths that correspond to multiples of a quarter wavelength at the operating frequencies, and by using transmission line lengths that correspond to multiples of a half wavelength at operating frequencies (Fig. 28).

Lengths are selected according to available space and apex height by using Chart 5 in topic 17. Next the separation between the feed point and the transmitter is estimated. Chart 2 is then used to determine a preferred length of transmission line. Refer to topics 1, 2, 9, and 17.

A practical 20-meter design is shown in Fig. 29. A 25- to 45-foot vertical mast was assumed. Formula leg length for three-quarter wave operation is:

$$\text{Leg length} = \frac{738}{14.2} = 52 \text{ feet}$$

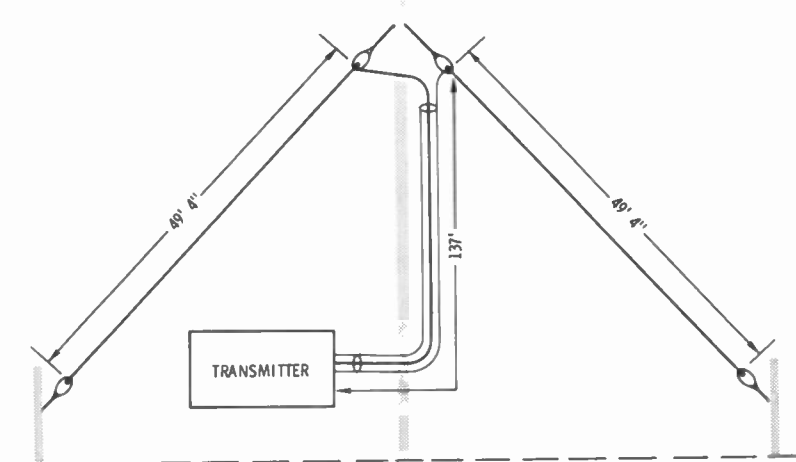

Fig. 29. Twenty-meter long-wire inverted vee—3/4 wavelength on each leg.

An estimate indicates that separation between feed point and second-floor location of transmitter is approximately 50 feet. The constants of Chart 2 indicate that a favorable transmission line length would then be:

$$\text{Line length} = \frac{650}{14.2} = 45' 9''$$

It is significant that an inverted-vee antenna is a sturdy construction. The mast itself does not support the antenna; rather the antenna wires contribute additional guying for the mast.

23 — Two-Band Inverted Long-Wire Vees— No Tuning

By choosing proper leg lengths for an inverted-vee antenna a single pair of wires can provide good performance on two bands. For example the length of an 80-meter inverted dipole is such that it will also resonate as a $7/2$ -wavelength antenna on 10 meters. Using the information of Chart 5, topic 17, the following formula values are obtained:

$$(80) \text{ Dipole leg length} = \frac{234}{3.9} = 60'$$

$$(10) \text{ Long-wire vee leg length} = \frac{1722}{28.6} = 60' 3''$$

In the practical situation the legs must be shortened from this value as shown in Fig. 30. In cutting antenna legs always use the values calculated from the chart. You can then shorten the legs with the antenna erected to set resonance on a desired frequency. In the case of two-band operation you must keep close watch on the resonance points in both bands. Inasmuch as the leg length has a more decided influence on the higher frequencies, it is wise to be conservative in trimming off the ends as you watch the change in resonance on the higher-frequency band. The dim-

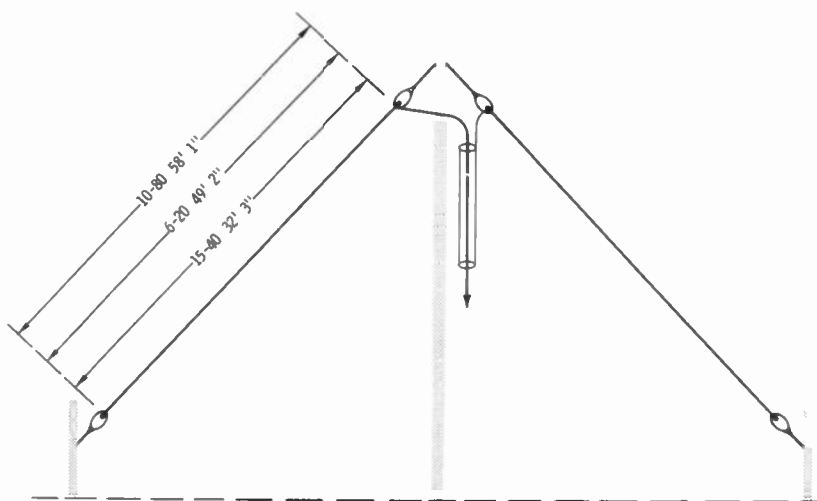

Fig. 30. Two-band inverted vee's.

ensions given in Fig. 30 provide a good combination for 10- and 75-meter single-sideband operation.

The 15- and 40-meter combination is a less favorable pair because the cut must be such that it will provide 40-meter c-w and 15-meter phone operation. Chart values are:

$$(40) \text{ Dipole leg length} = \frac{234}{7.1} = 33'$$

$$(15) \text{ Long-wire leg length} = \frac{738}{21.4} = 33' 6''$$

Note that on 15 meters the antenna operates as a 3/2-wavelength inverted vee (three quarter-wavelengths on a leg). A practical dimension which takes shortening effects into consideration is given in Fig. 30.

A third possible combination is a 6- and 20-meter inverted-vee antenna. This long-wire operates with legs three-quarters of a wavelength long on 20 meters and eleven quarter wavelengths on 6 meters. Formula calculations are:

$$(20) \text{ Leg length} = \frac{738}{14.2} = 52'$$

$$(6) \text{ Leg length} = \frac{2706}{52} = 52'$$

Dimensions for the practical cut are given in Fig. 30.

Various other combinations for two-band operation can be found by using Chart 5, in topic 17. Length selected depends on desired bands and the available physical space for the erection of the long-wire inverted-vee antenna. Sometimes a compromise choice must be made with regard to the resonance spectrum within each band, and it is not always possible to resonate at the exact frequency desired in each band. Refer to topics 1, 2, 9, 17, and 22.

24 — Two-Band Inverted Vee—End-Tuned

It is possible to resonate a two-band long-wire inverted-vee antenna at some specific frequency in each of the two bands to be covered simply by end-tuning each of the legs. A pair of alligator clips and two short segments of antenna wire permit optimum resonance on each of the two bands using the plan shown in Fig. 31.

In the previous topic 23 it was shown how a compromise length permits two-band operation. Exact-resonance frequencies can be obtained by cutting one length of line to the desired frequency in one band. Then, add on a short segment of line to establish the desired resonant frequency in the second band. This requires that the alligator clip be either connected or disconnected depending on the desired band of operation. This change-over, of course, can be done very conveniently because the leg ends are tied down at near ground level.

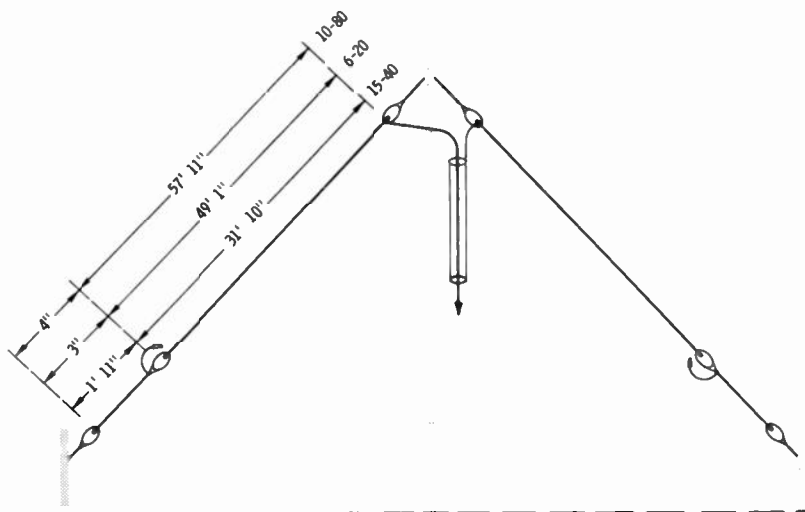

Fig. 31. Two-band inverted vee's, end-tuned.

Formula dimensions were given in the previous topic. The dimensions of Fig. 31 were planned for phone-band operation. In the case of the 15-40 antenna, the alligator clip would be open for 40-meter phone operation. Closing the two pairs of clips adds an additional 1' 11" to the antenna for optimum operation in the 15-meter phone band. If a 6-20 two-band combination is erected, the alligator clips are not connected for 20-meter phone operation. However, an additional 3" length is connected for operation on the 6-meter band.

For the 10-80 meter pair the clips are disconnected for 10-meter operation. For 80-meter phone-band operation, the two clips are connected.

The advantage of this manner of two-band inverted-vee operation is that the antenna can be peaked for optimum performance at any specific frequency within each band. The disadvantage is

that a short segment of line must be connected or disconnected when changing over from one band to the other. This really is a very simple operation, because it can be done conveniently (Fig. 32). Refer to topics 1, 2, 9, 17, 22, and 23.



Fig. 32. Alligator clips can be used to add length to an inverted vee.

25 — Long-Wire Inverted Vee—Sideband 10-15-2

Two attractive features of the inverted-vee construction are that the ends of the legs are near to ground where changes can be made conveniently and operation as a resonant antenna can be accomplished on more than one band with limited adjustments in leg length. The 10-15-20 single-sideband antenna demonstrates this versatility.

Preferred center frequency points were selected at 14.3, 21.3, and 28.6 megacycles. Reference to Chart 5 and suitable substitutions indicate that a practical inverted-vee can be operated as a $3/2$ -wavelength antenna on 20, a $5/2$ wavelength on 15, and a $7/2$ wavelength on 10. The required leg lengths are:

$$(20) \text{ Leg length} = \frac{738}{14.3} = 51.6'$$

$$(15) \text{ Leg length} = \frac{1230}{21.3} = 57.7'$$

$$(10) \text{ Leg length} = \frac{1722}{28.6} = 60.2'$$

Note that the difference spread is less than nine feet. Appropriate sections of wire for attachment to antenna ends can permit multi-band operation.

This antenna was constructed, and resonances at the desired frequencies were obtained with the dimensions given. Each antenna end includes three insulators and appropriate wire sections. Alligator clips (Fig. 32), or other means of interconnection are used to bridge across the first two insulators to permit operation on appropriate bands. Operation on 20 meters is accomplished by opening the clips nearest to the center feed point. With clip closed at the first insulator and open at the second on each leg, it is possible to obtain 15-meter operation. Finally with both pairs of clip connections closed, 10-meter operation is obtained. In this latter mode we also have a bonus in the form of 75-meter sideband operation as a simple inverted-vee dipole.

Of course, with the proper selection of frequencies and lengths, acceptable operation over each of the three bands can be obtained. An alternate plan is to cut to the high end of each band and use small clip-on sections to tune to any frequency on any band as shown in Fig. 18.

A length of transmission line must be selected to accommodate the three bands. Here again it is possible to come up with combinations that provide half-wavelength resonant lengths on the various frequencies, which, at the same time, are very near to each other in overall physical length. Trial substitutions using Chart 2 locate the following possibilities:

$$(20) \text{ Line length} = \frac{1950}{14.3} = 136' 4''$$

$$(15) \text{ Line length} = \frac{2925}{21.3} = 137' 4''$$

$$(10) \text{ Line length} = \frac{3900}{28.6} = 136' 4''$$

Cutting the transmission line to 137 feet provides fine matching on all three bands. Refer to topics 1, 2, 9, 17, and 22.

26 — All-Band 6-160 Inverted-Vee

Additional bands can be added to the basic inverted-vee construction of Fig. 33 by providing additional leg lengths. Top-band

160-meter operation is feasible without requiring any additional space by folding the legs back toward the mast (Fig. 34). This return span to the mast can be made at a height above ground of about 6.5 feet. This keeps all band-changing positions within easy reach.

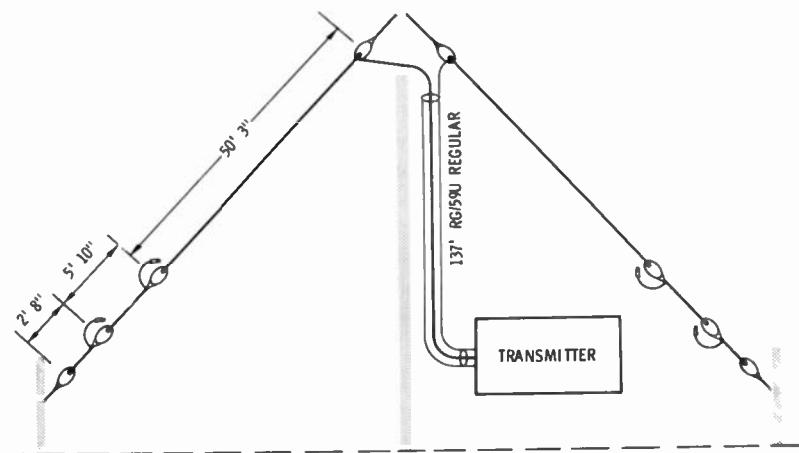

Fig. 33. 10-15-20 sideband long-wire inverted vee.

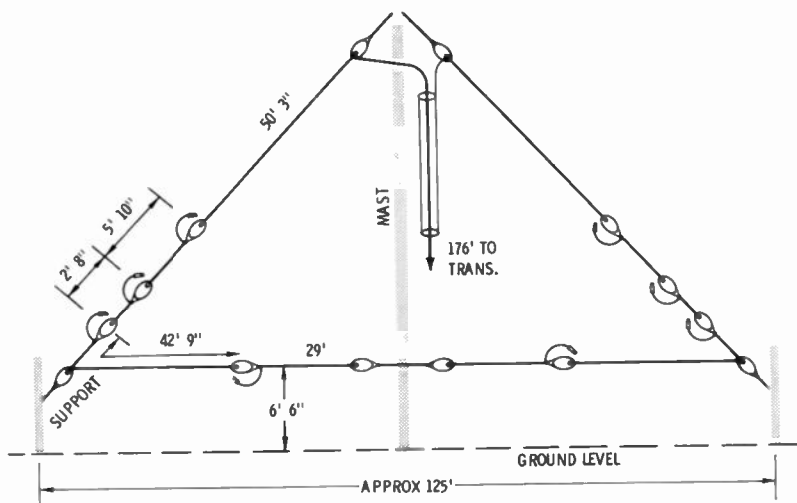

Fig. 34. 6-160 meter inverted dipole and long-wire inverted-vee system.

Adding a length of some 40 feet provides an overall leg length several inches more than 101 feet—the dimension for obtaining

three-quarter-wavelength operation on 40 meters. (As a bonus, this length also is a quarter-wavelength multiple of the 6-meter band). A further addition of somewhat less than 30 feet provides proper loading for 160-meter operation as a dipole.

In summary, all-band operation is possible with a single 35- to 45-foot mast in a space under 125 feet. Only one transmission line is needed, and no antenna tuner is required. The antenna operates as an inverted dipole on 80 meters, a modified inverted dipole on 160 meters, and as a long-wire inverted vee on the remainder of the bands. It is indeed a very inexpensive antenna despite its good all-band performance. Be careful in cutting the lengths, and be patient in tuning on each band, starting on 20 meters (shortest span), and continuing on through 160 meters (longest span). Refer to topics 1, 2, 9, 17, 22, and 25.

27 — 15-40 Novice Inverted Vee

The novice segments are so positioned in the 15- and 40-meter bands, that it seems plausible for a 40-meter dipole to also load on the 15-meter band, if dipole length can be cut in such a manner so that acceptable performance can be obtained on each band. This does not mean that *optimum* performance and the most

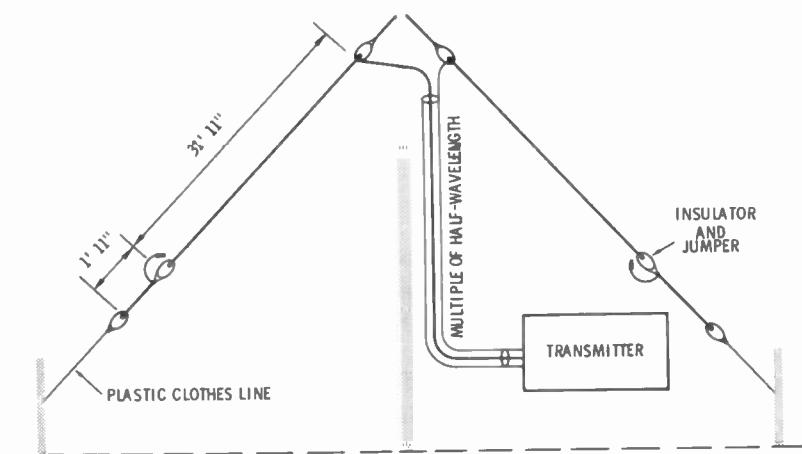

Fig. 35. Novice 15-40 inverted-vee antenna.

favorable line conditions can be obtained on each band. One can either favor one band or the other, or accept operation somewhat less than optimum on each band.

The inverted-vee construction, because the leg ends are near ground potential, can be adjusted to ensure top performance on each band. The inverted-vee dipole of Fig. 35 is cut precisely to the center of the 40-meter novice band. Calculated dimensions from topic 4 are 32' 8". The length of a three-quarter wavelength leg for 15-meter operation is slightly longer if ideal operation is desired:

$$(15) \text{ Leg length} = \frac{738}{21.175} = 34' 10''$$

It is very easy to add this additional leg length of approximately 2' 2" when changing over from 40- to 15-meter operation. Practical lengths (Fig. 35), are somewhat shorter as a function of height above ground.

Chart 2 can be used to calculate coaxial line lengths that are favorable for two-band operation. Half wavelengths of regular 72-ohm coaxial line are:

$$(40) \text{ Half-wave line length} = \frac{325}{7.175} = 45' 4''$$

$$(15) \text{ Half-wave line length} = \frac{325}{21.175} = 15' 4''$$

For a span of somewhat less than 100 feet, an optimum line length would be about 91' 6" (45' 4" × 2 and 15' 4" × 6). Refer to topics 1, 2, 4, 9, 10, 17, 22, and 25.

28 — 15-40-80 Novice Inverted Vee

The three novice bands are so situated frequency-wise that they do not lend themselves to the use of a single antenna for three-band operation when optimum performance is to be obtained on each channel. The exception is the inverted-vee which can be band-changed conveniently because its leg ends can be made readily accessible from the ground.

The inverted-vee antenna of Fig. 36 consists of segmented 40- and 80-meter inverted dipoles and a 15-meter long-wire inverted vee with three-quarter-wavelength legs. Only a single mast is needed (25 to 50 feet) and a single transmission line feeds from the transmitter to the center connection point at the top of the apex. Two metal fence posts can be the tie points for the leg ends. It should be possible to release these leg ends for convenient band changes.

Dimensions for the quarter-wave sides of the dipole based on band centers (Chart 4) are 62' 11", and 32' 8" for the 80- and

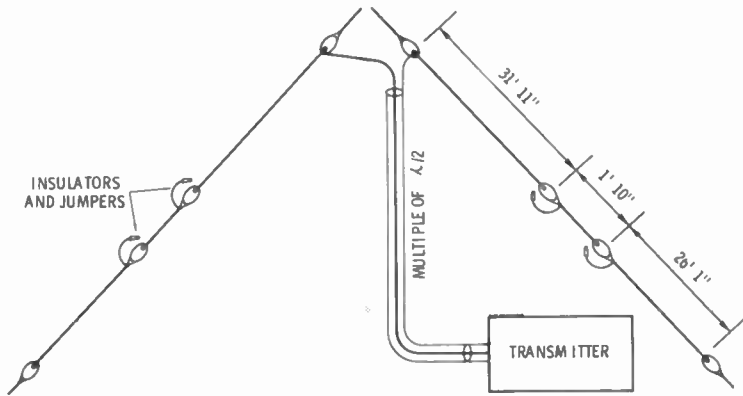

Fig. 36. 15-40-80 Novice-band inverted vee.

40-meter novice bands respectively. The three-quarter-wavelength dimension for 15-meter operation is:

$$(15) \text{ Leg length} = \frac{738}{21.175} = 34' 10''$$

Inverted-vee operation requires some shortening, and the practical dimensions for band-center resonances are as given in Fig. 36. Half-wavelength segments of line on the three bands have the following dimensions:

$$(80) \text{ Half-wave line length} = \frac{325}{3.725} = 87' 3''$$

$$(40) \text{ Half-wave line length} = \frac{325}{7.175} = 45' 4''$$

$$(15) \text{ Half-wave line length} = \frac{325}{21.175} = 15' 4''$$

For a separation of something less than 100 feet, a 91-foot transmission line (regular 72-ohm coaxial) would suffice (87' 3" × 1, 45' 4" × 2, and 15' 4" × 6). Refer to topics 1, 2, 4, 9, 13, 17, 22, and 27.

29 — 10-15-20 and 20-40-80 Inverted-Vee Trios

This is a three-section antenna that permits three-band operation without requiring any antenna changes. Operation can be selected on the basis of the triples 10-15-20 or 20-40-80. Two other triples can be selected if desired. These are 10-20-40 or 15-20-80. The antenna is a combination of the 20-40-80 inverted dipoles of topic 14 and long-wire inverted vees. Any of the three-band trios listed can be set up using appropriate jumpers. No changes need be made when switching among the three selected bands.

The antenna operates as inverted dipoles on 40 and 80, three-halves wavelength antennas on 15 and 20, and a nine-halves wavelength antenna on 10 meters. Preferred lengths of transmission line are multiples of 45 feet for phone operation and 46 feet for cw.

Calculations for phone-band operation are as follows:

$$(80) \text{ Dipole length} = \frac{234}{3.9} = 60'$$

$$(40) \text{ Dipole length} = \frac{234}{7.25} = 32' 3\frac{1}{2}''$$

$$(20) \text{ } 3/4\text{-wave leg length} = \frac{738}{14.25} = 51' 9''$$

$$(15) \text{ } 3/4\text{-wave leg length} = \frac{738}{21.3} = 34' 6''$$

$$(10) \text{ } 9/4\text{-wave leg length} = \frac{1722}{28.6} = 60' 4''$$

Actual dimensions for a practical version are shown in Fig. 37. Of course, frequencies can be selected and legs cut to meet your needs. Refer to topics 1, 2, 9, 13, 14, 17, and 22.

30 — W3FQJ Inverted-Vee 6-Through-80 Sidebander

In maintaining multiband schedules, net activities, participating in multiband sideband contests, and for general all-band operation, it is convenient to have a good single antenna that requires no changes when changing bands. Such an antenna can be constructed using the principles of the inverted dipoles and the long-wire

inverted-vees. Appropriate combinations and proper cutting provides sideband operation on each band from 6 through 80 meters. No tuner is needed.

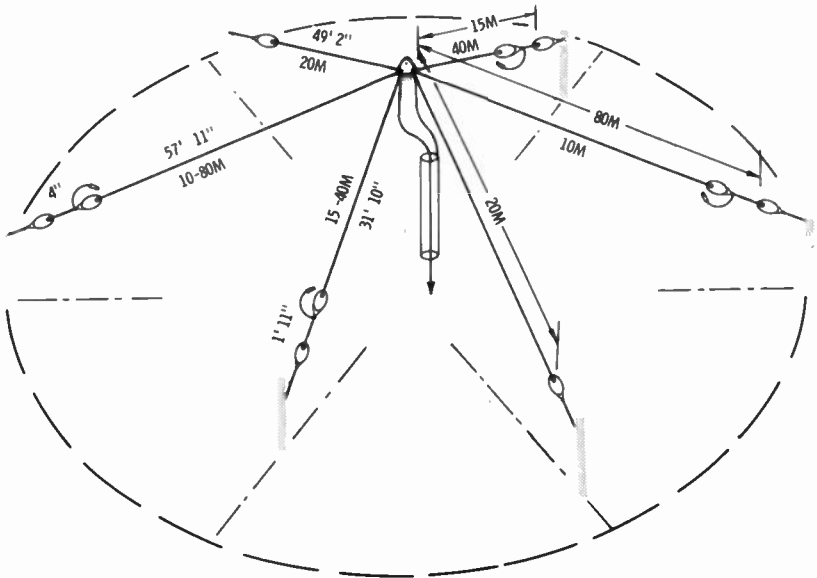

Fig. 37. Inverted-vee trios.

Three inverted vees (Fig. 38) are connected to a common feed point; a separation of 60° is maintained between legs. Two vees are inverted dipoles cut to resonate in the 40- and 80-meter phone bands. The third element is a three-halves wavelength long-wire (three-quarter wavelength on a leg) cut for the 20-meter phone band. These three elements also provide operation on 6, 10, and 15 meters. The 40-meter segment functions as a three-quarter wavelength long-wire on 15 meters while the 80-meter element operates $7/2$ wavelength on 10. The 20-meter vee operates as an $11/2$ -wavelength antenna on 6 meters.

The length of the transmission line should be a compromise that approximates a length corresponding to a whole multiple of a half wavelength on each band. This is feasible using a length of coaxial cable (velocity factor of 0.66) that is a whole multiple of 90 feet in length. Inasmuch as matching is seldom a problem with 80-meter dipoles, a multiple of 45 feet is equally good.

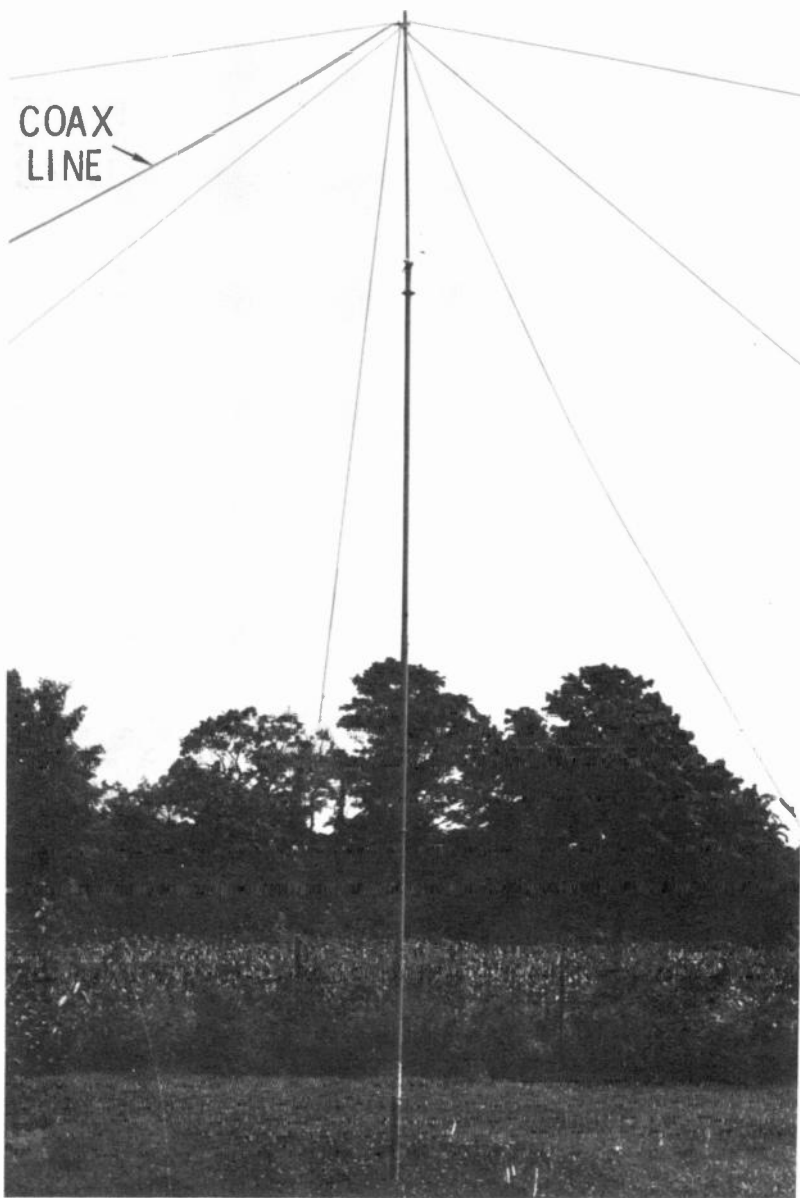

Fig. 38. W3FQJ inverted-vee sidebander.

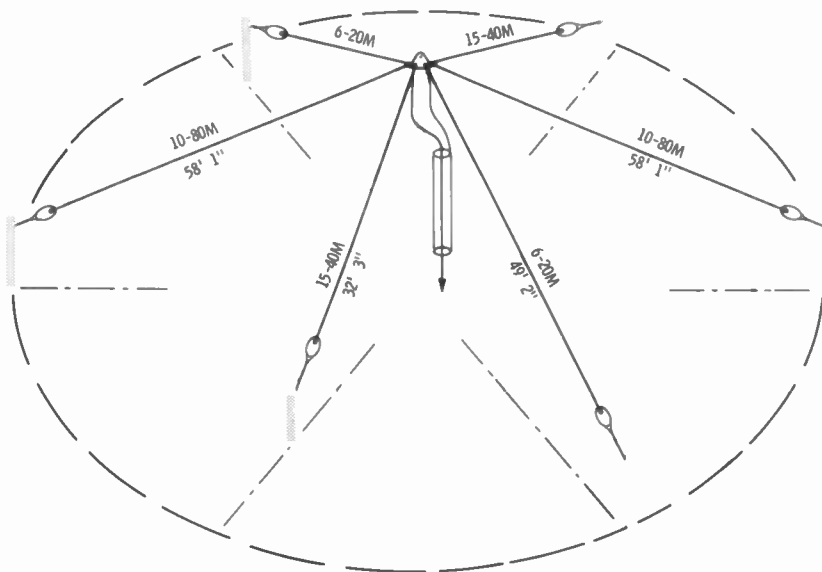

Fig. 39. W3FQJ inverted-vee 6 through 80 sidebander.

Practical dimensions for the inverted-vee construction are somewhat shorter than the formula values. The dimensions of Fig. 39 establish the following resonances:

- 80 meters—3.9 MHz
- 40 meters—7.2 MHz
- 20 meters—14.3 MHz
- 15 meters—21.42 MHz
- 10 meters—28.58 MHz
- 6 meters—51.4 MHz

Refer to topics 1, 2, 9, 13, 14, 15, 17, and 22.

31 — Long-Wire Inverted Vees With Line Tuner

A line tuner mounted at the transmitter end of a transmission line has as its major function the optimum loading of the *transmitter*. Within sensible operating limits, it is capable of establishing a standing-wave ratio less than 1.5 to 1 over a substantial frequency range. It permits the transmitter to see this proper load even though the standing-wave ratio on the transmission line might be quite high. Two additional benefits of the line tuner is that optimum operating conditions can be established over an entire amateur band even though the antenna is peaked

on one segment of that band, and multiband operation of an antenna is feasible without making any antenna changes when switching bands. Tuner adjustments must be made but this is done right at the operating position. The use of a line tuner is not a cure-all, but it does offer transmitter protection and contributes some convenience and versatility. Refer to Appendix VI.

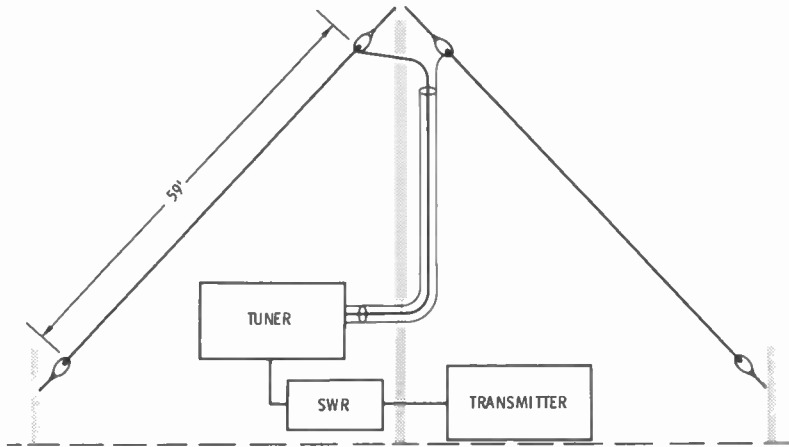

Fig. 40. 10-15-20 long-wire inverted vee, line-tuned.

The inverted-vee antenna of Fig. 40 is adaptable to the use of a simple line tuner. This is a version of the inverted-vee antenna discussed in detail in topic 25. The antenna has been cut to its longest dimension of 59 feet. The tuner discussed in Appendix VI when used with this antenna permits low-SWR operation on 10, 15, and 20 meters without making any antenna changes. Standing-wave ratios of less than 1.3 to 1 are attainable over the entire three bands. The antenna also loads well on both 40 and 80 meters with standing-wave ratios of less than 1.5 to 1.

If space is available, leg lengths can be increased. For example a leg length of 77.5 feet will load well on 10, 15, and 20 meters (leg lengths approximate $9/4$, $7/4$, and $5/4$ wavelengths respectively). The antenna will also load on 40 and 80 meters using the line tuner of Appendix VI. Commercial match boxes can be employed with this style of antenna. Refer to topics 1, 2, 9, 17, 22, and 25.

SECTION 3

Long-Wire Antennas

32 — Single Long-Wire Resonant Antennas —Center-Fed

Antennas can be resonated to a specific frequency by making their overall electrical length a whole multiple of a half wavelength. A low-impedance feed point can be found by making each of the legs an odd multiple of a quarter wavelength long. Legs can be equal or of unequal lengths just so each is some multiple of an odd quarter wavelength.

When additional electrical length is added to an antenna, changes are made in the radiation pattern. In the case of a horizontal long-wire antenna, the greater its length is, the higher is the gain, the greater is the number of horizontal lobes, and the more directional the antenna becomes in the directions off its ends.

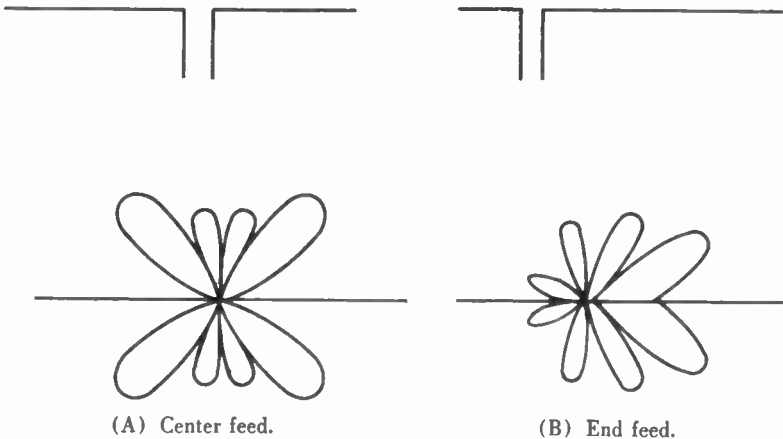

Fig. 41. Lobes of 2-wavelength long wire.

When such an antenna is center-fed, the antenna lobes are symmetrical on each side of the feed point (Fig. 41A). When such an antenna is fed at a low-impedance point near one end, the lobes on the long-leg side become the stronger and orient them-

selves nearer to the direction of the antenna wire as compared to the short-side lobes (Fig. 41B).

Some theoretical horizontal patterns are given in Fig. 42 for various long-wire electrical wavelengths. Note the increase in the number of lobes and end directivity as length is increased. In using such an antenna at practical heights above ground, the nulls are less sharp, and the pattern tends to fill in so that more uniform radiation results.

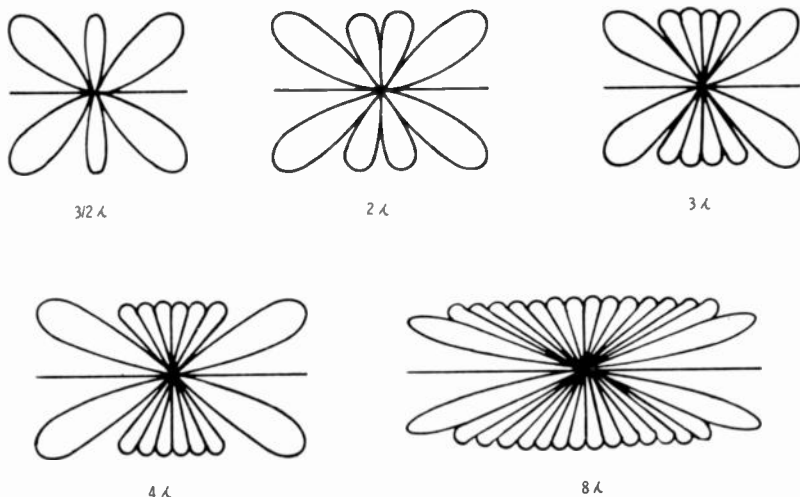

Fig. 42. Influence of long-wire length on horizontal pattern.

A practical long-wire antenna is shown in Fig. 43. Its dimensions are attractive because they permit 10- and 15-meter operation. Lengths are such that the antenna operates as a 2.5-wavelengths radiator on 15 and 3.5 wavelengths on 10. In the practical version, resonant frequencies were found to be 21.32 MHz on 15, and 28.4

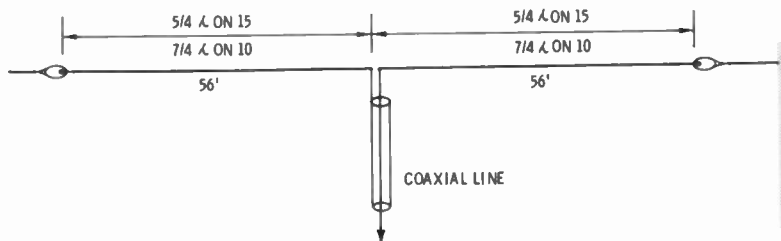

Fig. 43. Long-wire center-fed antenna for 10 and 15 meters.

MHz on 10. Direct connection to the transmitter without any intervening tuner is possible if the transmission-line length approximates a whole multiple of an electrical half wavelength. Refer to topics 1, 2, 16, and 17.

33 — Single End-Fed Monoband Long-Wire Resonant Antennas

Long-wire antennas can be fed conveniently a quarter wavelength in from one end. By so doing the length of the transmission line between the transmitter and antenna often can be reduced substantially. The quarter-wave displacement from the end locates a low-impedance feed point, and for antennas no more than several wavelengths long, a suitable direct match can be made to a low-impedance coaxial line (Fig. 44A). A four-to-one balun matches a longer antenna (Fig. 44B).

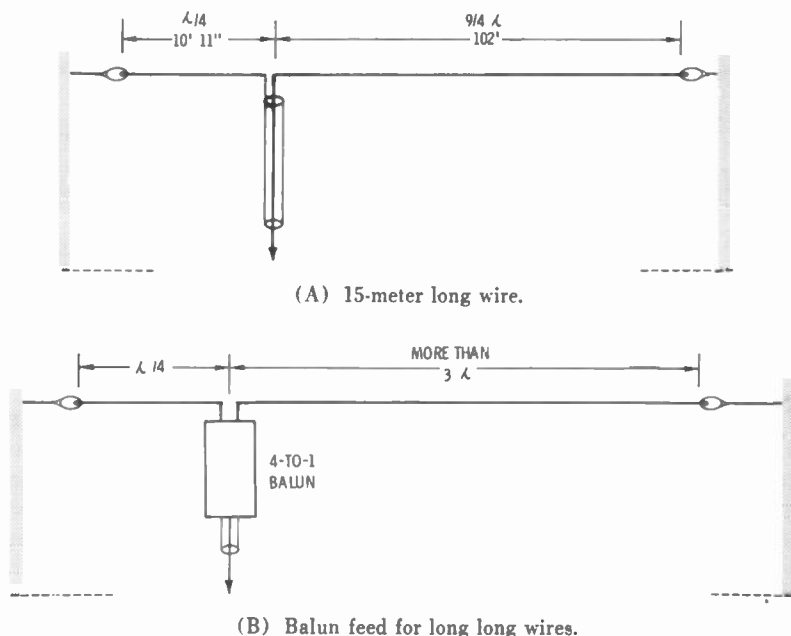

Fig. 44. End-fed long-wire antennas.

In general, the impedance of an end-fed long wire of a given length is higher than a center-fed version (topic 32). Furthermore the end-fed type is more directional in the direction of the long leg as compared to the short leg. Both legs of the antenna must

be trimmed carefully to establish resonance and to have the wave-distribution position a low-impedance at the feed point. Each leg should be made an odd multiple of a quarter wavelength long.

Note that the antenna of Fig. 44A is identical to that of Fig. 43. However it is end-fed rather than center-fed. In so doing, it becomes a single-band 15-meter antenna rather than a 10-15 combination. It is more directional (in the direction of the long leg) and, if one end is located near the transmitter, only a short length of transmission line is needed.

A 20-meter end-fed long-wire antenna is shown in Fig. 45. The long leg of the antenna has an electrical length of four and one-quarter wavelengths ($17\frac{1}{4}$). Using Chart 5 this would calculate as:

$$\text{Long-leg length} = 4182/14.2 = 294'$$

$$\text{Short-leg length} = 234/14.2 = 16' 5''$$

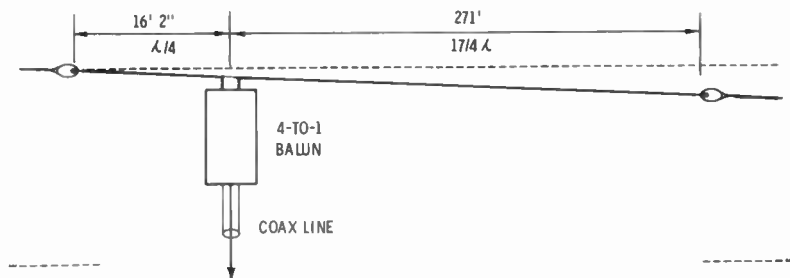

Fig. 45. Twenty-meter long-wire antenna with tilt.

As shown in Fig. 45 physical leg lengths are somewhat shorter. The best plan for determining leg lengths is to first cut them according to formula and then trim back slowly to find exact resonance. When close to resonance, the short leg should be trimmed inch by inch. Because the long leg is of much greater length, more wire must be trimmed off to produce the same change in resonant frequency. In trimming the antenna of Fig. 45 the long leg was cut back one foot at a time until resonance dropped into the band and then cut in 6-inch steps.

For effective low-angle radiation, the height of a horizontal antenna should be a half wavelength on the operating band. In recent years good results have been obtained by tilting long-wire antennas slightly in the direction of maximum propagation to obtain more favorable low-angle emission when the antenna height

must be made less than a half wavelength. The antenna of Fig. 45 had its near and far ends 45 and 38 feet high, respectively.

Transmission-line length was made a whole multiple of the electrical half wavelength at the desired frequency. Refer to topics 1, 2, 16, 17, and 32.

34 — 10-15-20-40 Long-Wire WAS Special

When multiband operation is desired, both ends of a long-wire antenna can be segmented (Fig. 46). In this arrangement insulators and alligator-clip jumpers are employed in changing bands. The ends of such an antenna can be dropped toward ground making the band-change jumpers accessible from the ground or a step ladder. The segmented arrangement is attractive because the antenna can be preset on each band to obtain optimum operation. No tuner is needed and a good match can be made to a low-impedance coaxial line using a 4-to-1 balun.

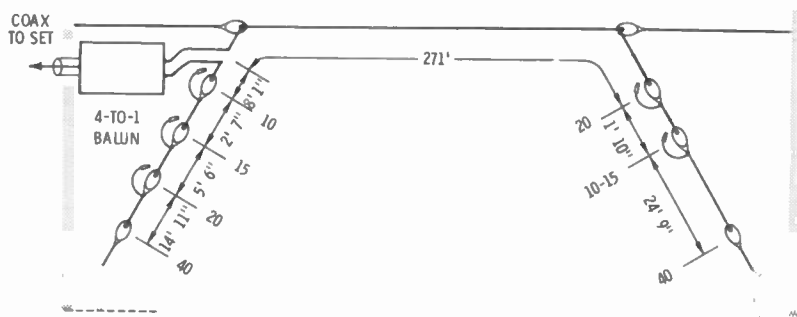

Fig. 46. 10-15-20-40 segmented end-fed long wire.

The longer the long leg is, the higher is the antenna gain, and the more directive is the radiation pattern off its end. The unidirectional characteristic permits the favoring of a given direction, while the multiplicity of secondary lobes provides reasonable omnidirectional performance. If there is a cluster of states that give you trouble, point the antenna in their direction.

If one lives along the east coast, the long leg can be pointed west. Conversely, for a western station the long leg can be directed east. In the central states you may prefer a bidirectional center-fed type, or perhaps, the end-feed unidirectional characteristics if you are having difficulties with certain states.

The length of the short leg can be calculated using the regular dipole equation. The long leg must be made some multiple of a quarter wavelength.

$$\text{Long leg} = \frac{246 \times n}{f\text{MHz}} \text{ feet}$$

$$\text{Short leg} = \frac{234}{f\text{MHz}} \text{ feet}$$

where,

n equals the number of quarter wavelengths.

The antenna legs must be trimmed carefully to find resonance and establish a feed-point impedance that can match the transmission-line system. Short sections should be trimmed off the quarter-wave segment to obtain resonance just as you trim an ordinary dipole. Because the long leg is so very long, it is possible to trim off larger pieces of the antenna wire in moving toward the desired resonant point.

For DXing the long-wire can be tilted slightly in the direction of the long leg (as shown in Fig. 45) to improve the low-angle radiation in the favored direction.

The arrangement and dimensions of a practical antenna are given in Fig. 46. The quarter-wave dipole segments are easy to set up and permit 10- through 40-meter operation. For 10-meters the first jumper is left open. For 15-meter operation, the first jumper is closed and the second jumper is opened. Twenty meter operation has the first two jumpers closed and the third jumper opened. For 40-meter operation, all jumpers are connected.

The long leg of the antenna is $9/4$ wavelengths long on 40, $17/4$ on 20, $25/4$ on 15, and $33/4$ on 10. Formula values are as follows:

$$(40) \text{ Leg length} = \frac{2214}{7.2} = 307 \text{ feet}$$

$$(20) \text{ Leg length} = \frac{4182}{14.2} = 294 \text{ feet}$$

$$(15) \text{ Leg length} = \frac{6150}{21.3} = 288 \text{ feet}$$

$$(10) \text{ Leg length} = \frac{8118}{28.6} = 283 \text{ feet}$$

After trimming, the practical lengths reduce to 297' 7", 271', and 272' 10" respectively. Note that the same leg length can be

used for both 10- and 15-meter operation. Thus in changing operation between the two high-frequency bands, only the jumpers at the feed end need be shifted.

The bearing of the long leg, as erected in eastern Pennsylvania, was set at 255° . On 10 meters where the directivity is sharpest, a strong-signal belt ran diagonally across the continental U.S. At the same time, good reports were obtained in the southern states and in north central states, thanks to the secondary lobes. Of course, on the lower bands the number of electrical wavelengths on the legs is not as great, and the horizontal radiation pattern is less sharp, thus encompassing a larger area of major-lobe coverage. Refer to topics 1, 2, 16, 17, 18, 19, 32, and 33.

35 — Single Random Wire With Line Tuner

One of the most convenient antennas is a single length of wire in association with a tuner (Fig. 47). The simple tuner of Appendix VI does a fine job. The random length of wire employed should be at least one-quarter wavelength at the lowest operating frequency. If 10- through 80-meter operation is desired, the total length of the random wire should be approximately 60 feet. Increase the length to about 123 feet if 160-meter operation is desired.

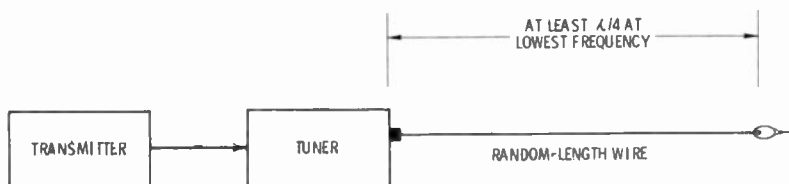

Fig. 47. Random-length single-wire antenna and tuner.

The most favorable operation is obtained when the total length of the random wire is such that its impedance at the tuner end is low. A quarter wavelength of antenna presents such a low impedance to the tuner. Try to avoid antenna lengths that are multiples of a half wavelength because they present a maximum impedance point to the tuner. It is wise then to use random lengths of wire that fall rather close to those obtained using Chart 5. Usually a compromise length can be found that does not present a high impedance to the tuner on any one of the bands you wish to operate.

For example, 40- and 80-meter Novice-band operation would indicate a random-wire length somewhere between 80 and 100 feet. Although a length of 60 feet presents a quarter wavelength on

80 meters, this becomes a half wavelength on 40 meters, and it will reflect a maximum impedance to the tuner.

Line tuners can of course be employed with a variety of antennas cut for single-band or multiband operation. The tuner permits such an antenna to be loaded as a random-wire type on other bands. Remember that random-wire loading means that the transmission line also becomes a part of the radiating system. In most instances the loading involves the inner conductor of the coaxial transmission line and whatever antenna wire is attached to this inner conductor. Thus, in determining the random-wire loading of another antenna type, the total radiating length is based on the total length of the transmission line and the active antenna leg. Refer to topics 1, 2, 17, 31, 32, 33, and 34.

36 — Resonant Antenna Plus Random-Wire Loading

The antenna of Fig. 46 can be used as an example of resonant antenna plus random-wire loading. Such an antenna loads readily on both 80 and 160 meters as a random-wire model with the antenna set for 20-meter operation (Fig. 48). Furthermore, it loads on 10 and 15 meters without requiring any jumper change. Even though the tuner is active, the antenna loads in normal fashion on 20 meters. On 80 and 160 meters, it loads as a random wire, with the inner conductor of the transmission line becoming part of the antenna. On 10, 15, and 40 meters the long leg is active, and there is some radiation from both the line and the short antenna leg. If you prefer to keep the SWR at a minimum on the transmission line, you can jump in the appropriate leg segments for each band.

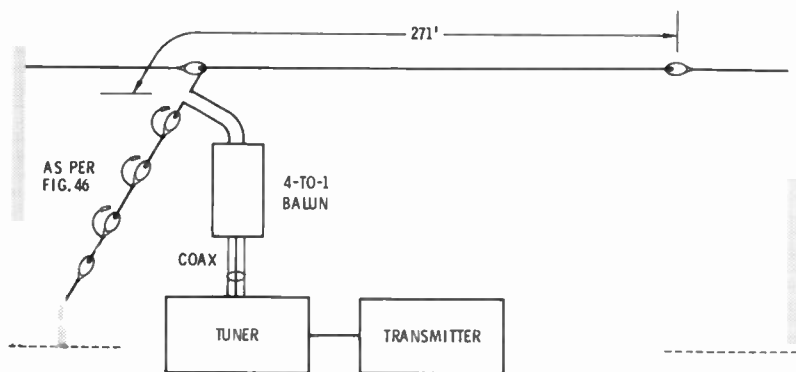

Fig. 48. Combination long-wire antenna and random-wire antenna with line tuner.

A line tuner in conjunction with the antennas of Fig. 43 and Fig. 44A permits operation on both the 20- and 40-meter bands. The antenna functions as discussed in topics 32 and 33 on 10 and 15 meters. However, in conjunction with the transmission line, it operates as a random-wire style for 20, 40, and 80 meters. In fact, if the transmission line itself is long enough, it will also load on 160 meters (total length of line plus the length of the long leg should be at least 130 feet). Refer to topics 1, 2, 17, 31, 32, 33, 34, and 35.

SECTION 4

Vee-Beam Antennas

37 — End-Fed Monoband Inverted-Vee Beam

An inverted-vee antenna can be end-fed as shown in Fig. 49. A low-impedance feed point is found by attaching the transmission line at a point one-quarter wavelength away from one of the leg ends. The other leg is made much longer. The apex point is at the center of the total antenna span. No tuner is needed when the overall length of the long span is made an odd quarter wavelength long. Low standing-wave ratios are possible without too-critical adjustments of the overall length.

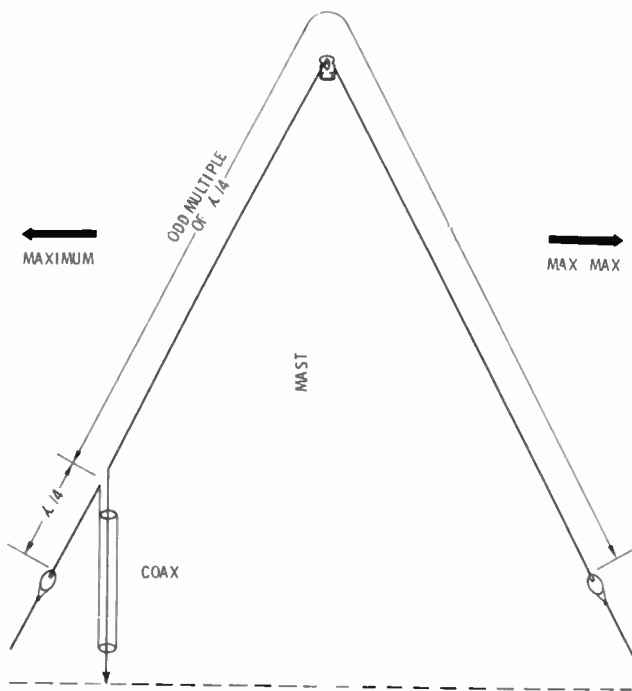

Fig. 49. End-fed inverted-vee beam.

Coaxial-line feed can be used. However, the lowest possible standing-wave ratios are obtained over a greater span of frequencies when a 4-to-1 balun is employed.

When a long-wire vee antenna is end-fed, there is maximum radiation off the ends (Fig. 49). The longer the antenna is, the higher is its gain, the greater is its directivity parallel to the wires, and the greater is the relative radiation off the long-leg end as compared to the short-leg side. This type antenna combines the features of the single long-wire resonant antenna and the long-wire inverted-vee antenna (topics 22 and 33). In this case both the feed point and the leg ends are near ground level. Quite often it is possible to locate the feed end of this antenna very near the transmitter and only a very short length of transmission line is needed.

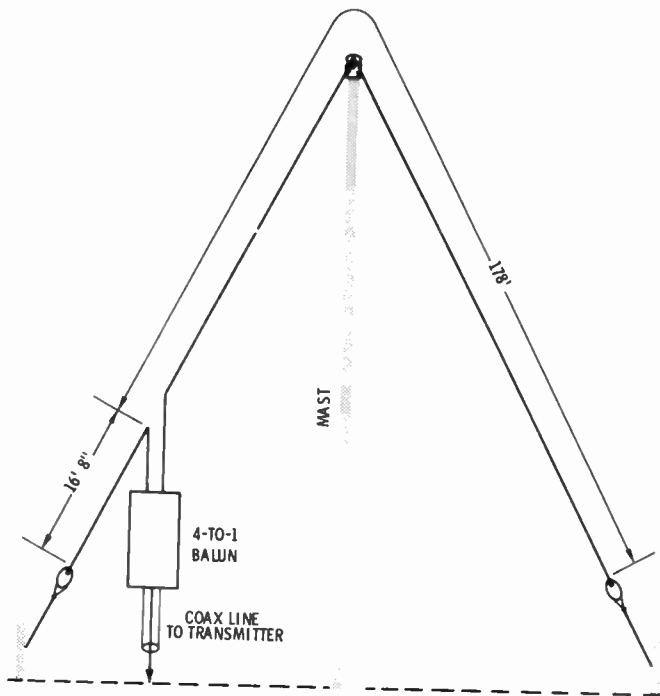

Fig. 50. Twenty-meter inverted-vee beam.

An example for 20 meter operation is given in Fig. 50. The long leg has been trimmed down from the calculated value for $1\frac{1}{4}$ wavelength:

$$\text{Long-leg length in feet} = \frac{2706}{14.2} = 190' 6''$$

$$\text{Short-leg length in feet} = \frac{234}{14.2} = 16' 5''$$

Actual dimensions for a practical version are given in Fig. 50. Apex height was 45' above ground. Refer to topics 1, 2, 22, and 33.

38 — 10-, 15-, and 20-Meter Inverted-Vee Beam

Two attractive features of the inverted-vee end-feed arrangement are: that the leg ends and feed point are accessible from ground level where changes can be made conveniently, and operation as a resonant gain antenna can be accomplished on more than one band with limited changes in overall leg length.

An antenna with legs properly segmented for sideband operation is shown in Fig. 51. Reference to Chart 5 and suitable substitu-

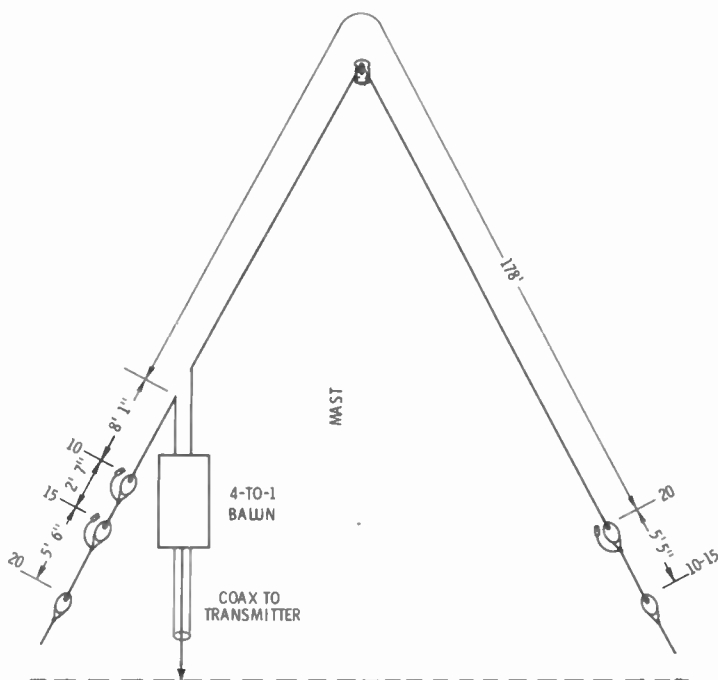

Fig. 51. 10-15-20 inverted-vee beam.

tions indicate feasible dimensions for the long leg of $11\frac{1}{4}$ wavelength on 20, $17\frac{1}{4}$ wavelength on 15, and $23\frac{1}{4}$ wavelength on 10:

$$(20) \text{ Long-leg length} = \frac{2706}{14.2} = 190' 6''$$

$$(15) \text{ Long-leg length} = \frac{4182}{21.35} = 195'$$

$$(10) \text{ Long-leg length} = \frac{5658}{28.6} = 197' 8''$$

Short-leg lengths can be cut using the values (Chart 1) of 16' 6", 11', and 8' 2" for 20, 15, and 10 meters respectively.

Practical dimensions as constructed by the author are given in Fig. 51. By proper trimming of the long leg a very minimum standing-wave ratio can be obtained on a given frequency or operating segment of each band. However, the antenna is relatively noncritical as to the precise leg length once the overall length is brought reasonably near to a given band. Operation on 10 and 15 meters is possible with the same length for the long leg. Preferred transmission-line length is a whole multiple of an electrical half wavelength (multiple of 45' 6").

Operation on 40 meters requires some additional length on the feed end of the antenna (Fig. 52). Some length must be removed

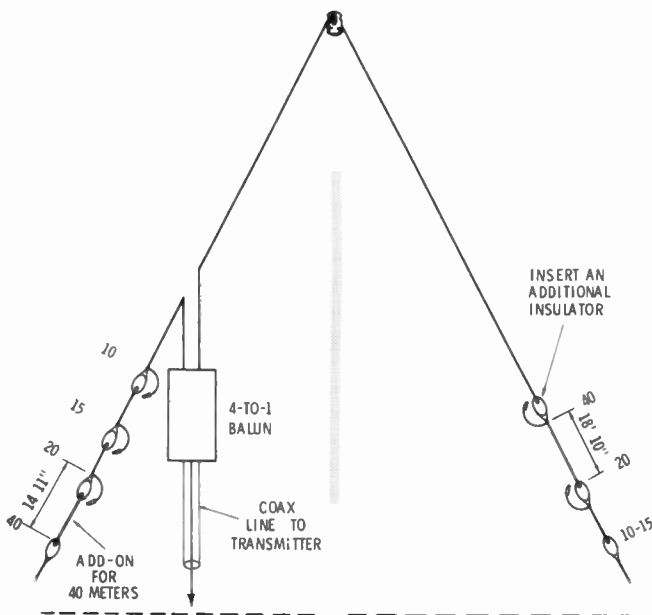

Fig. 52. Adding 40 meters to antenna of Fig. 51.

from the opposite end to permit an electrical length of $5/4$ wavelength on 40. This places the jumper point rather high on the long leg and convenient facility must be included to release this side of the antenna to make 40-meter band changes. Refer to topics 1, 2, 17, 22, 25, 33, and 37.

39 — Four-Band Inverted-Vee Beam With Tuner

A simple tuner of the type described in Appendix VI can be used conveniently with the inverted-vee style of antenna. Such a tuner can be positioned at the transmitter where its function would be to make certain that the transmitter operates into a proper load regardless of antenna resonance and standing-wave conditions on the line. A more efficient plan of feeding is to locate the tuner at the antenna feed point (Fig. 53). Here its responsibility would be to match the antenna to the transmission line; therefore, there is minimum standing wave developed on the transmission line, regardless of the frequency of operation. The transmitter also sees the proper load looking into its end of the transmission line.

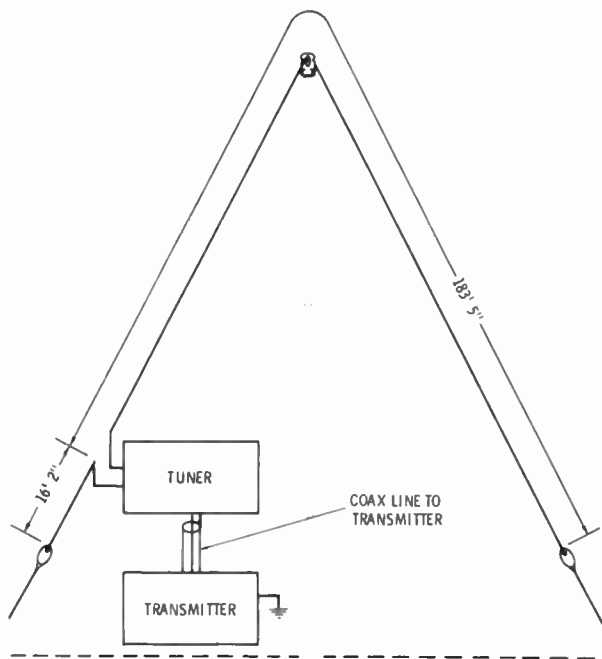

Fig. 53. Long-wire inverted vee with tuner.

No changes in the physical length of the antenna need be made in changing bands: however, the tuner must be readjusted. Leg lengths correspond to the longest used for the antenna of topic 38 when operated as a 10-, 15-, or 20-meter antenna. The tuner also loads the antenna on 40 meters without requiring any additional length on the feed side or change in overall length of the long leg.

The tuner is adjusted on each band by first using a dummy load to find the transmitter settings that represent optimum operation into 50 ohms. Low power is supplied to the antenna system. The tuner switches and controls are now adjusted for a minimum standing-wave ratio. Proper settings are recorded in a notebook for ease in making band changes. Refer to topics 1, 2, 17, 22, 31, and 38.

40 — Three-Halves-Wavelength Horizontal Vee

The $3/2$ -wavelength antenna as covered in topic 17 has a low-impedance feed point at the center and $3/4$ -wavelength legs. Instead of the two lobes of a dipole the $3/2$ -wavelength antenna has four major and two minor lobes (Fig. 21). This antenna can be made more directive by appropriate forward tilting of the legs (Fig. 54).

When the legs are tilted forward horizontally, the antenna displays a maximum directivity along a line that bisects the

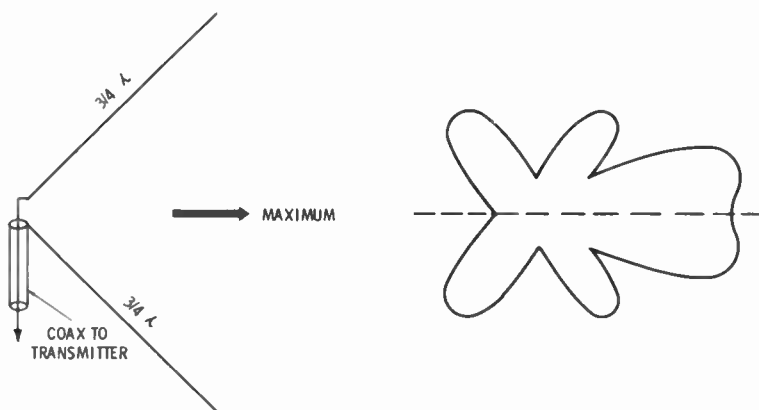

(A) Maximum-radiation direction.

(B) Radiation pattern.

Fig. 54. Basic $3/4$ -wavelength vee.

included angle. Minor side and back lobes remain; therefore the antenna has omnidirectional capability as well. The included angle between the two legs should be approximately 90° and may be as high as 110°.

Leg lengths are based on the 3/4-wavelength value of Chart 5. In most cases the horizontal-vee type antennas require some 4 to 6 percent shortening from the chart formula values. Calculations for 10, 15, and 20 meters are:

$$(20) \text{ Leg length} = \frac{738}{14.2} = 52'$$

6 percent shortening reduces length to 49'.

$$(15) \text{ Leg length} = \frac{738}{21.3} = 34' 6''$$

6 percent shortening results in a leg length of 32' 6''.

$$(10) \text{ Leg length} = \frac{738}{28.6} = 25' 10''$$

6 percent shortening results in a leg length of 24' 3''.

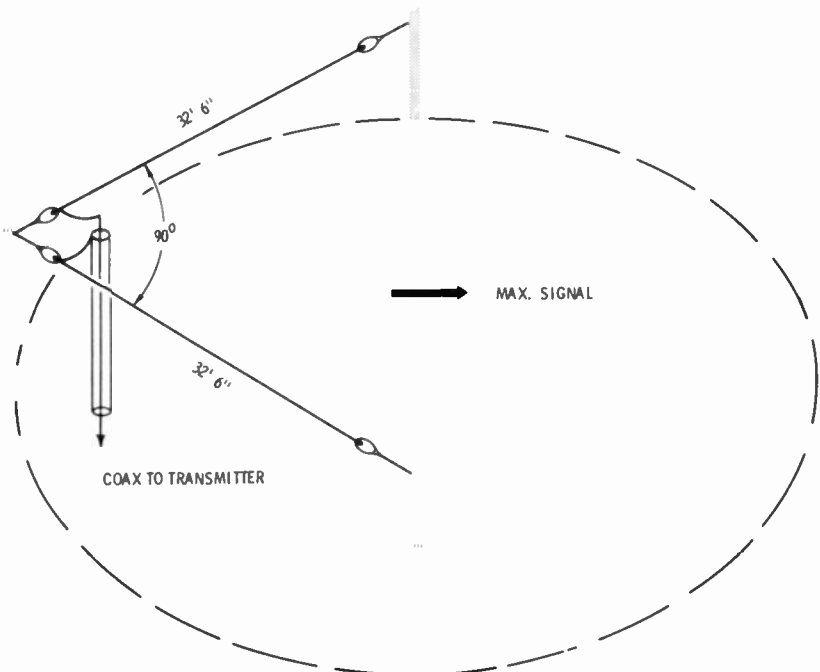

Fig. 55. 15-40 horizontal vee.

Cutting the legs down 6 percent from the formula values produced resonant points quite near the frequencies substituted in the above equations. Cut your transmission-line length to an even multiple of an electrical half wavelength. Refer to topics 1, 2, 16, and 17.

41 — 15-40 Three-Halves-Wavelength Vee

The frequency relationship between the 15- and 40-meter bands permits two-band operation, as a dipole on 40 and as a $3/2$ -wavelength antenna on 15 (Fig. 55). A wise choice of leg length permits good two-band operation. Such an antenna has a reasonably omnidirectional pattern on 40 and 15 meters plus a maximum 15-meter directivity in a line that bisects the included angle (Fig. 55).

In the practical antenna the optimum leg length was found to be 32' 6", producing a very low SWR on 40 meters and a somewhat higher value on 15, but no greater than 1.5 to 1 at any fre-

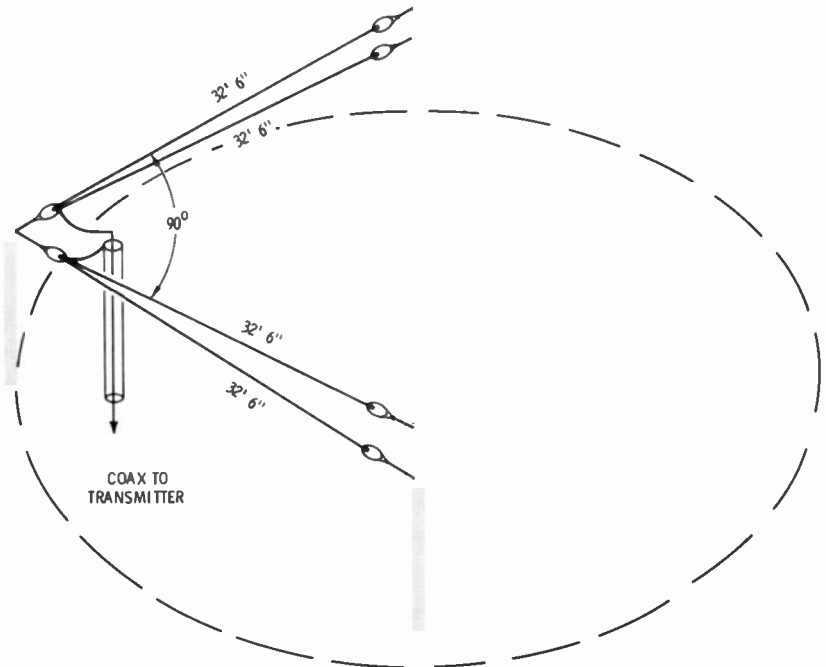

Fig. 56. 15-40 conical vee.

quency on the two bands. Cut your transmission line length to a whole multiple of an electrical half wavelength. Refer to topics 1, 2, 16, 17, and 40.

42 — 15-40 Conical Three-Halves-Wavelength Vee

Antenna resistance can be raised and bandwidth increased by attaching additional legs to the basic vee style of antenna. The antenna of Fig. 56 uses four legs (two on each side of the center feed point). A leg length of 32' 6" was found to be optimum for 15- and 40-meter band operation as a dipole on 40 and as a 3/2-wavelength antenna on 15.

In this arrangement a very low SWR was attained on 15 meters and a somewhat higher figure on 40 meters (the converse of the antenna of topic 41). The included angle was 90° and transmission-line length was an even multiple of an electrical half wavelength. Refer to topics 1, 2, 16, 17, 40, and 41.

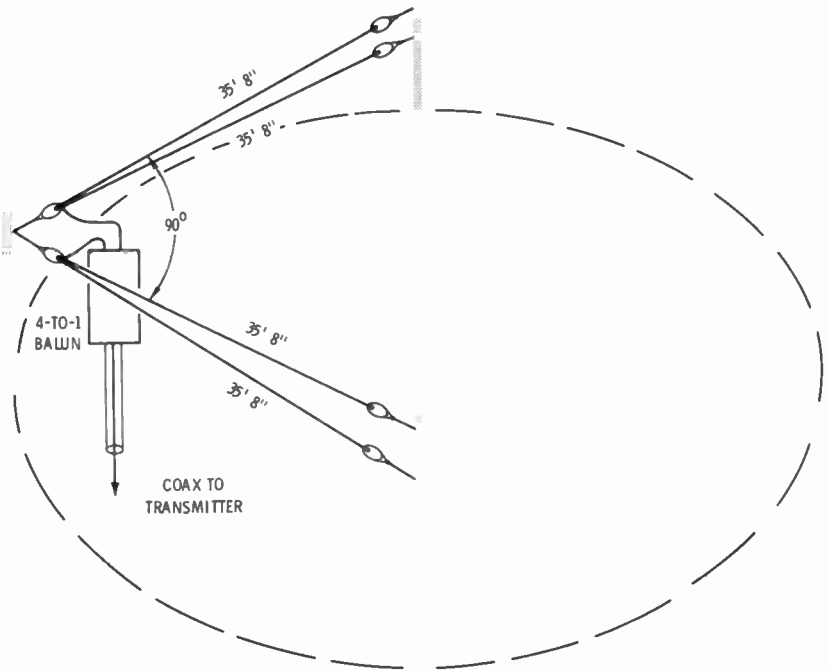

Fig. 57. Conical vee with balun.

43 — 15-40 Conical Vee With Balun

A uniformly lower SWR can be attained by using a balun in association with the conical style antenna (Fig. 57). The balun when used with the basic antenna of topic 42 provides lower and more uniform SWR readings over the two bands.

The presence of the balun has an influence on the resonant points. In general the antenna legs must be cut somewhat longer to establish the same resonant points. With the wideband balun used by the author, it was found that the leg lengths fell very near to the formula values of Chart 5. In fact, on occasion, optimum results were obtained by making leg lengths somewhat longer than calculated values. The leg length of 35' 8" was found optimum for two-band operation when the balun was added to the antenna of topic 42.

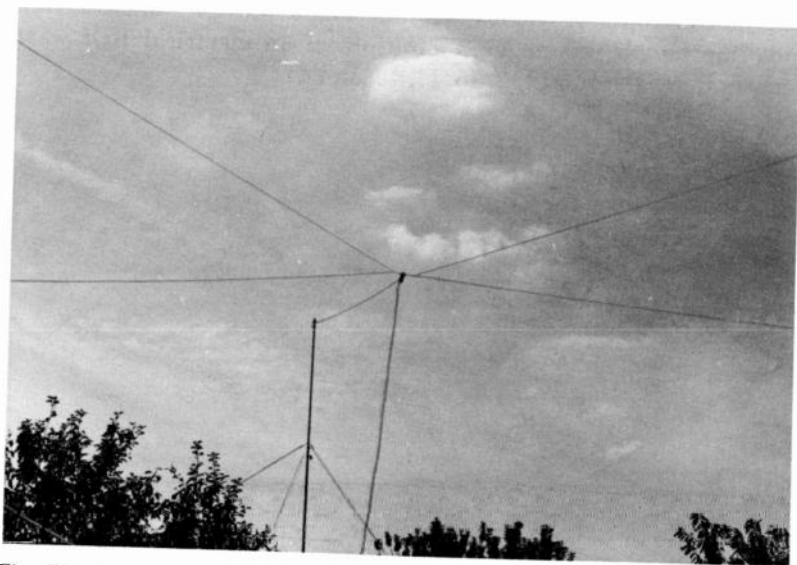

Fig. 58. Conical-vee antenna showing antenna wires, balun, transmission line, and center support mast.

The conical construction is shown in the photograph of Fig. 58. The two pairs of antenna wires connect to the balanced high-impedance side of the balun. A coaxial transmission line links the balun to the transmitter. Plastic clothesline supports the body of the balun and also establishes the proper angle between the two leg pairs. Three masts or high support points are needed. Refer to topics 1, 2, 16, 17, 40, 41, and 42.

44 — Short Horizontal Vee-Beam Antenna

The vee-beam antenna takes advantage of the directional characteristics of a long antenna wire. If two antenna wires are used jointly and have the proper included angle, the radiation lobes combine in such a manner that the antenna displays maximum directivity in a line that bisects the included angle (Fig. 59). To maintain this favorable combining of lobes, there must be a proper angle between legs. The longer the antenna legs are in wavelengths, the smaller is the included angle. Chart 6 relates leg length in odd multiples of a quarter wavelength to the optimum angle.

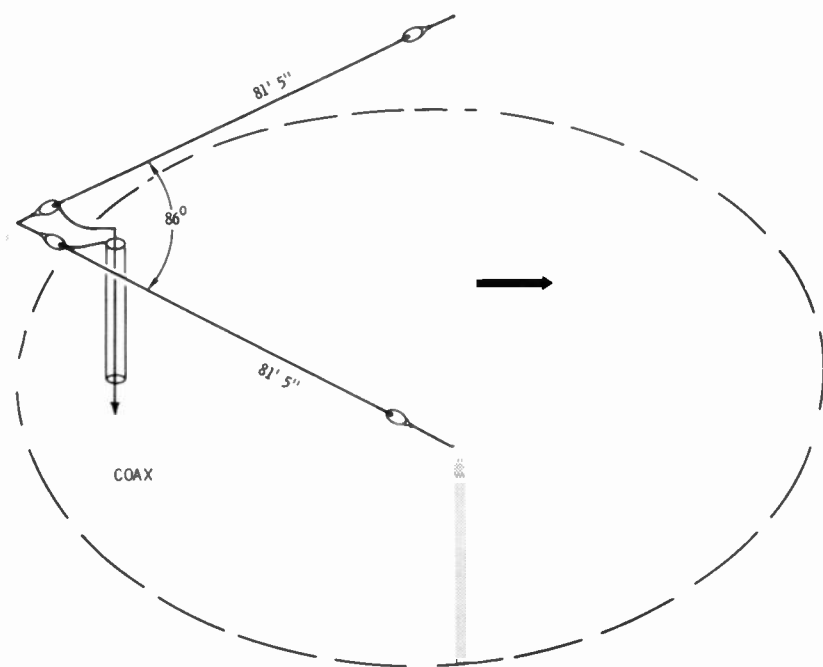

Fig. 59. Short vee beam for 20 meters.

Inasmuch as necessary mounting space, matching, and other considerations differ for a very-long vee antennas and shorter ones, the two basic constructions are covered separately in this book. An antenna with leg lengths shorter than 100' or $1\frac{1}{4}$ wavelength, whichever is the shorter, is considered a short horizontal vee beam.

Practical dimensions for a short horizontal vee beam for 20-meter operation can be obtained from the appropriate chart. Leg lengths for 5/4-wavelength operation from Chart 6 are:

$$(20) \text{ Leg length} = \frac{1230}{14.2} = 86' 6''$$

Using 6 percent shortening, the leg length reduces to 81' 5".

Chart 6 suggests an antenna angle of 86°. Such an antenna has a gain of 3.3 dB.

Chart 6. Angle Between Wires for Short Vee-Beams

Leg Length in Wavelength (λ)	Angle	Gain (dB)
3/4 λ	100°	2.5
5/4 λ	86°	3.3
7/4 λ	76°	4.0
9/4 λ	67°	4.75
11/4 λ	60°	5.3

Antenna resistance rises slowly with leg length. It is also influenced by the included angle. It has been found that the short vee-beam antennas (two-wire type) can be connected directly to a low-impedance coaxial transmission line. No tuner is needed for matching. Cut your line to a whole multiple of an electrical half wavelength. SWR ratios are no greater than 2 to 1 and substantially lower over most of the band. If this is a matter of concern to you, a simple line tuner such as described in Appendix VI can be used at the transmitter end of the line. No tuner is needed at the feed point. Refer to topics 2, 17, 31, 40, and 41.

45 — Duo-Band Horizontal Short Vee Beams

A proper choice of leg length permits two-band operation of a short vee beam. In addition to the 15-40 combination covered in topics 41 and 42, other possible pairs are 10-15, 10-20, and 10-80. Practical dimensions are given in Fig. 60.

The 10-15 antenna with a leg length of 56' operates 5/4 wavelength on 15 meters and 7/4 wavelength on 10 meters. The 49' leg length is a compromise choice for 5/4-wavelength operation on 10 and 3/4-wavelength on 20. The 60' leg length is a compromise that provides simple dipole operation on 80 meters and 7/4-wavelength on 10.

A compromise apex angle for the three antennas is about 80° to 85°. In general, the smaller the apex angle is, the greater

must be the leg length for a given resonant frequency. Leg shortening may only be 2 to 3 percent of the formula values using Chart 5, and in some cases leg length must be very near to the formula values. Refer to topics 1, 2, 17, 40, 41, and 44.

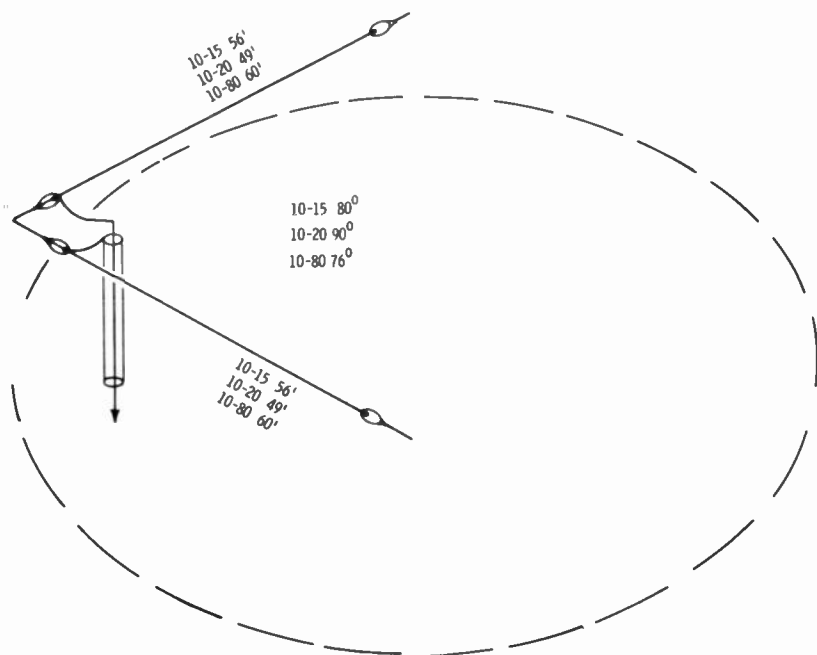

Fig. 60. Duo-band short vee beams.

46 — Tilted Short Vee Beams

The short vee beam has a reasonable omnidirectional characteristic with a maximum directivity in a line that bisects the angle between the two legs. Good low-angle radiation is obtained when a horizontal antenna has a one-wavelength height above ground (heights below 0.5 wavelength give only marginal performance). For low erection, some improvement in low-angle propagation can be obtained by tilting the vee-beam antenna so that the leg ends are below the center feed point (Fig. 61).

A short vee beam used successfully by the author had a feed-point elevation of 40 feet and leg-end heights of 30 feet. Operation in this manner improved the low-angle DX characteristics of the antenna but harmed the omnidirectional characteristics. Results seemed to indicate that there was no great change in the hori-

zonal directivity pattern, but there was a possible increase in the vertical angle in other than the forward direction. In the forward direction, the low-angle radiation was improved. Leg lengths employed were the same as given in topics 44 and 45. Refer also to topics 1, 2, 33, 40, and 41.

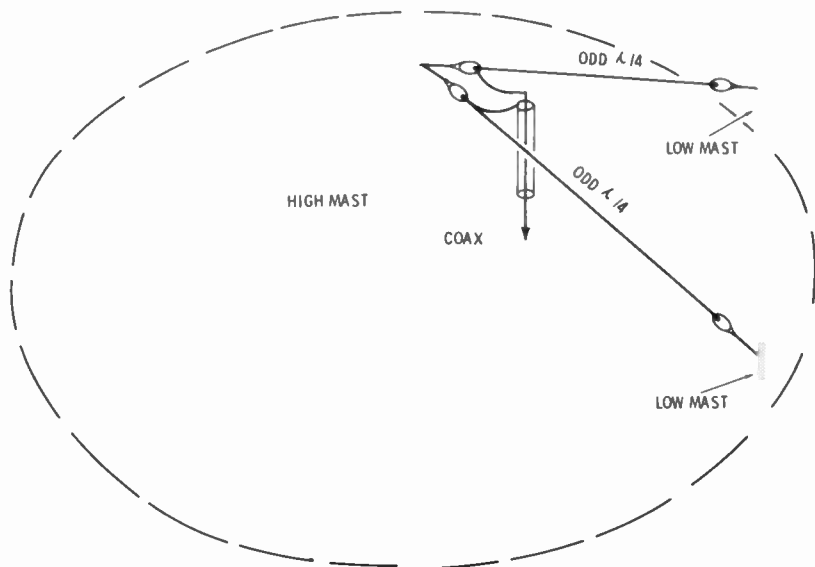

Fig. 61. Tilted vee beam.

47 — 10-15-20 Short Vee Beam

Three-band operation of a short horizontal vee is feasible using two pairs of legs of differing length. No tuner is needed and quick band changes can be made. In a practical version of this idea (Fig. 62) one pair of legs is cut for optimum two-band operation on 10 and 15 meters. A leg length of 56' was employed as in topic 45. The other pair of legs of 51' 2" provide optimum operation on 20 meters. The two pairs of legs span outward from the center feed point reaching a ten-foot separation at the leg ends. Thus the antenna has a conical appearance (Fig. 63) but the legs on each side are of differing lengths. Cut critically for sideband operation, the SWR can be kept below 1.5 to 1. The compromise angle is 80°.

The short vee beam is a good all-around antenna and emphasizes a favored direction. This antenna erected along the east coast with the bisecting direction toward the south would give three-

band coverage of South America, and at the same time good state-side results would be possible. Refer to topics 1, 2, 7, 40, 44, and 45.

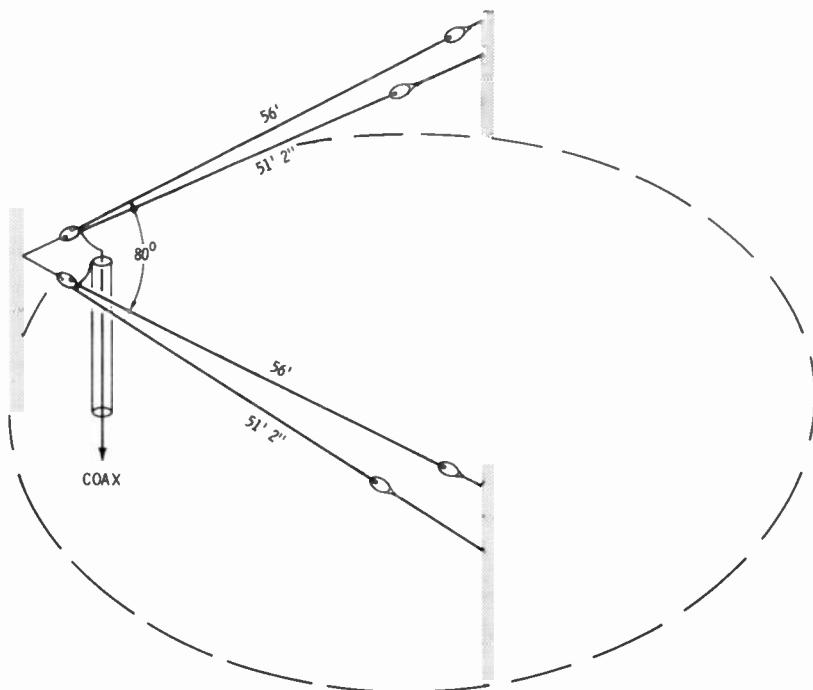

Fig. 62. 10-15-20 short vee beam.

48 — 10-15-20-40 One-Hundred Footer

In this antenna book we have arbitrarily selected 100 feet as the maximum length for a short vee beam. In fact, this easy-to-remember dimension is a good compromise value for 15- and 40-meter operation. On 40 meters, each leg is $3/4$ wavelength long, while for 15-meter operation, the electrical length is $9/4$ wavelengths long. On 15 meters the antenna resistance remains low enough to permit direct connection to a coaxial line (Fig. 64).

Formula values are:

$$(40) \text{ Leg length} = \frac{738}{7.2} = 102.5 \text{ feet}$$

$$(15) \text{ Leg length} = \frac{2214}{21.3} = 104 \text{ feet}$$

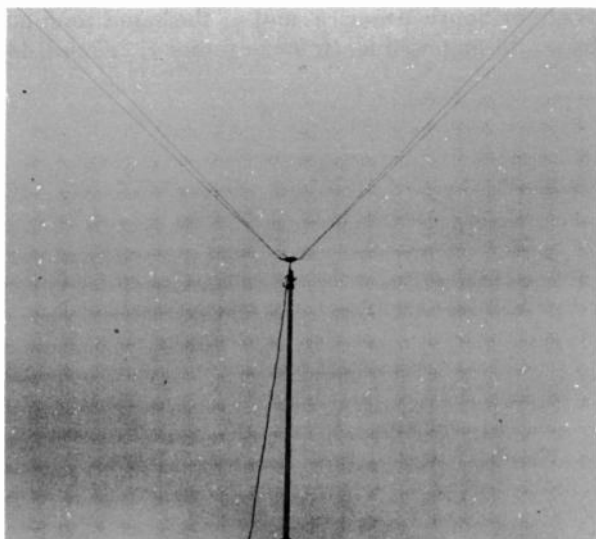

(A) Feed-point arrangement.

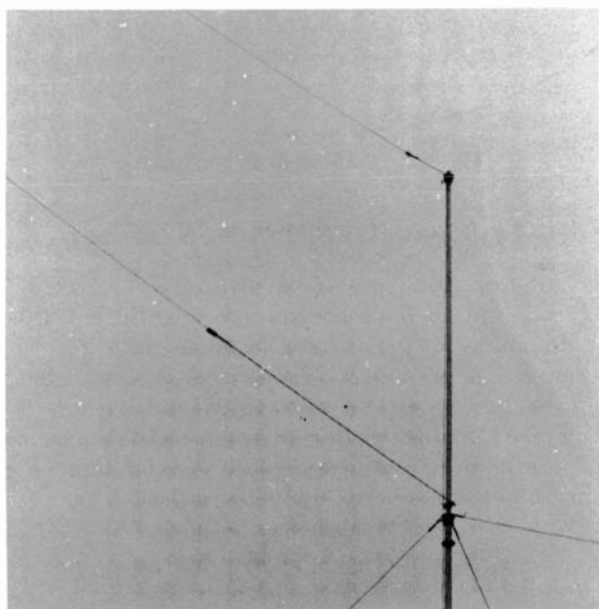

(B) Far-end view.

Fig. 63. 10-15-20 short vee.

The practical compromise value is 100 feet. Suitable apex angles fall between 67 and 75 degrees.

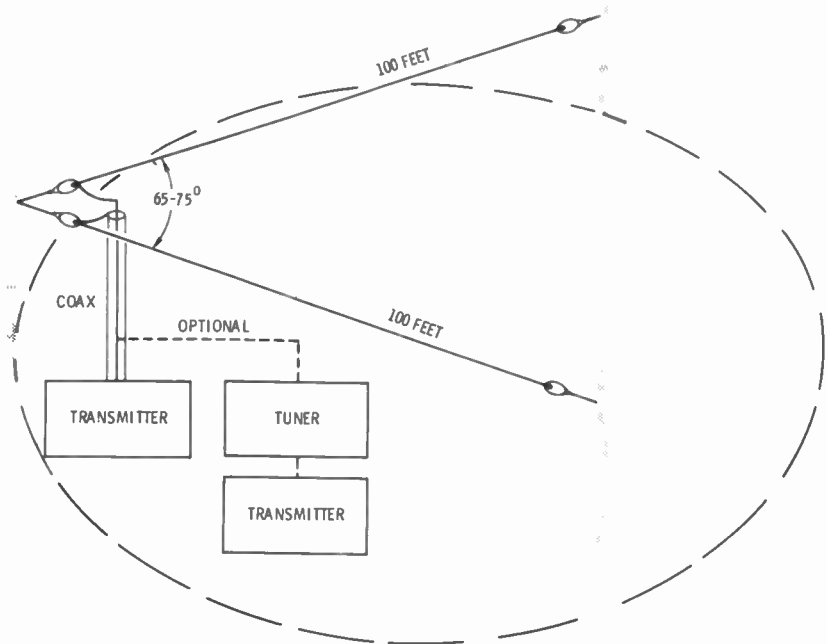

Fig. 64. Multiband 100-footer.

This short vee-beam antenna also functions on 10 and 20 meters. If a coaxial transmission line is cut rather carefully to a length that is a whole multiple of an electrical half wavelength on 10 meters, the SWR is low in the active sideband sections of the 10-, 15-, and 40-meter bands. Lower SWR ratings for 10- and 20-meter operation can be obtained with the use of the simple tuner described in Appendix VI. Refer to topics 1, 2, 7, 31, 35, 44, 45, and 48.

49 — 10-15-20-40 Short Vee Beam

Two pairs of vee-beam wires joined together at the feed point and spanning out to a separation of ten feet at the far end can provide multiband operation without the need for a tuner. This can be accomplished by cutting the two pairs of vee wires with differing lengths as shown in Fig. 65. The 100-foot vee provides

operation on 15 and 40 meters, while the shorter pair is 84 feet and optimized for 10- and 20-meter operation. The apex angle is 65 to 75 degrees, and the length of the transmission line is made an optimum whole multiple of an electrical half wavelength. Refer to topics 1, 2, 17, 44, 45, and 48.

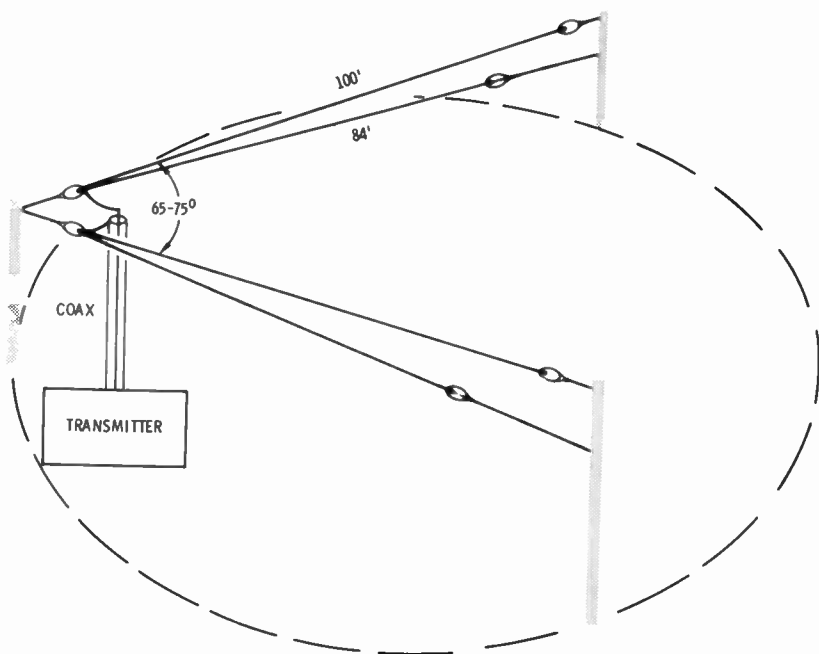

Fig. 65. 10-15-20-40 short vee beam.

50 — 10-15-20-40-80 Vee Beam and Inverted Dipole

It is possible to add 80-meter operation to the antenna of topic 50 in two ways. A 60-foot pair of antenna wires can be connected to the vee beam. However, this requires a substantial additional span of plastic clothesline or rope, or two separate masts for the 80-meter element. An effective approach is to simply add an 80-meter inverted vee (Fig. 66) to the short vee-beam construction. Inasmuch as the 60-foot 80-meter segment also resonates in the 10-meter band, there is some 10-meter omnidirectional radiation that is beneficial for local 10-meter operations. Refer to topics 1, 2, 17, 44, and 49.

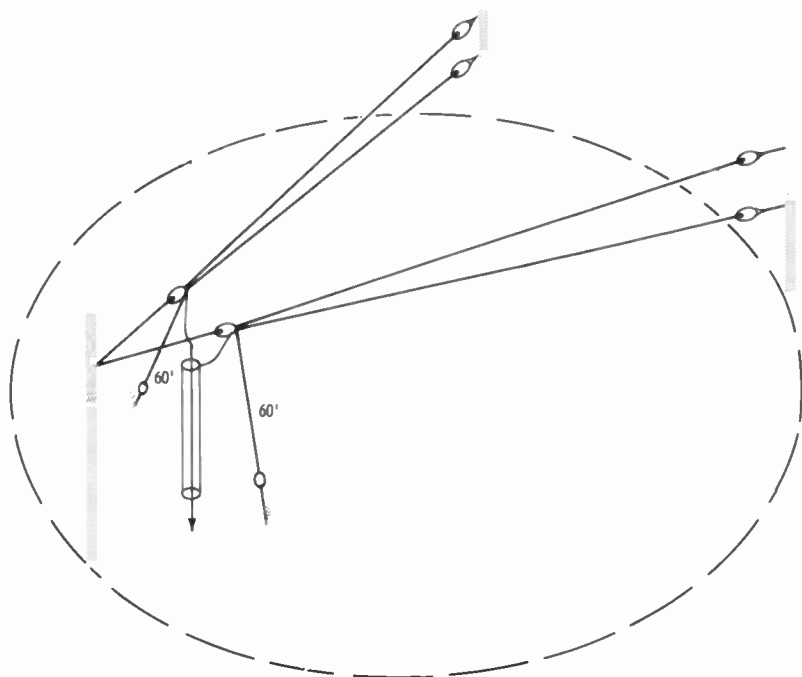

Fig. 66. Short vee-beam antenna of Fig. 65 with an attached 80-meter inverted dipole.

SECTION 5

Long Vee-Beam Antennas

51 — Long Horizontal Vee-Beam Antenna

In this book, the long horizontal vee-beam antenna is considered to have a leg length in excess of 100 feet, or three-quarters of a wavelength, whichever is the longer. As compared to the short vee beam there is a higher gain and a smaller angle between the two vee wires. Maximum radiation is again along the bisector line of the two wires. Orientation of a maximum lobe along this bisector line requires a proper angle as related to leg length. Chart 7 lists required angles and gain values as related to leg lengths.

Fig. 67. The basic long vee-beam antenna.

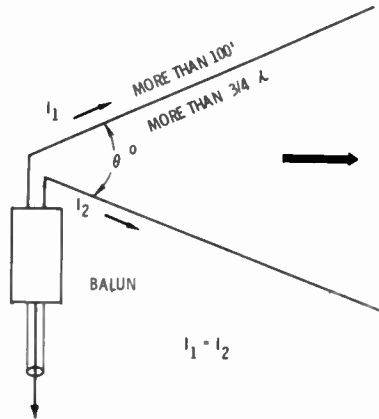

A matching balun is recommended for the long vee beams. Ratios of 2 to 1 or 4 to 1 are suitable (Fig. 67). The unbalanced-to-balanced (balun) coils ensure equal currents in the two leg wires. This is an important consideration for the long vee beams if the maximum lobe is to be aligned precisely along the bisector direction. It is less of a consideration for the short vee beam because of the inherent broadness of the maximum lobe.

An example demonstrates the planning process. Assume that a 10-meter vee beam is to be erected with a possible gain of 10.7 dB. From Chart 7 the leg length is $39/4$ wavelengths and the

recommended angle is 32° . The formula value of the leg length from Chart 5 is:

$$(10) \text{ Leg length} = \frac{9594}{28.6} = 335.4 \text{ feet}$$

In a practical version of this antenna with the feed point 50 feet in the air and the two ends 45 feet high, leg length had to be reduced to 329 feet to obtain resonance at 28.6 MHz (Fig. 68). A 4-to-1 balun was employed, and the overall length of the 50-ohm transmission line was a whole multiple of an electrical half wavelength.

Chart 7. Angle Between Wires for Long Vee Beams

Leg Length in Wavelengths (λ)	Angle	Gain (dB)
11/4 λ	60°	5.3
13/4 λ	56°	5.8
15/4 λ	52°	6.3
17/4 λ	48°	6.8
19/4 λ	46°	7.2
21/4 λ	44°	7.6
23/4 λ	42°	8
25/4 λ	40°	8.4
27/4 λ	38°	8.8
29/4 λ	37°	9.2
31/4 λ	36°	9.6
33/4 λ	35°	10
35/4 λ	34°	10.3
37/4 λ	33°	10.5
39/4 λ	32°	10.7
41/4 λ	31°	10.9

How much erection space is required for the above antenna? This is a simple trigonometric calculation using the sine natural functions (Fig. 69 and Chart 8). Each leg of the vee is the hypotenuse of a right triangle with the bisector line being one side. The included angle is 16° ($32/2$). Therefore the distance between one of the leg ends and the bisector line (side A) is:

$$A = 329 \times \sin 16^\circ = 329 \times 0.2756 = 90.7 \text{ feet}$$

The separation between the two ends of the vee legs is twice this value or slightly more than 181 feet.

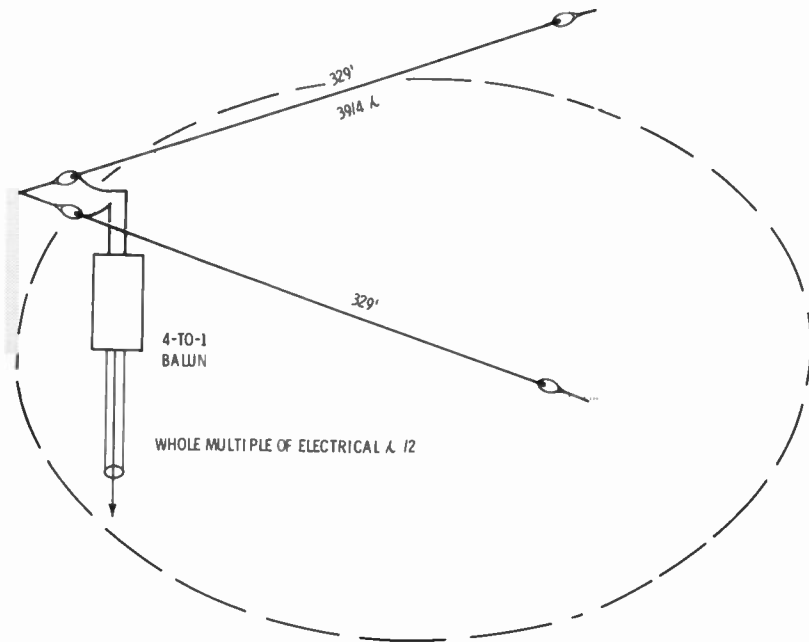
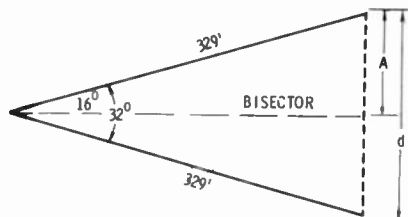

Fig. 68. Ten-meter long vee beam.

Fig. 69. Vee-beam angles and sides.



As in the case of the short vee beam, the lower the frequency of operation is, the longer the leg length must be, and the greater the erection space per a given gain. Antenna height too is a consideration and should be no less than one-half wavelength above ground. This means that for a 20-meter operation the vee-beam height should be no lower than 35 feet (approximately 0.5 wavelength), while the best low-angle results are obtained by using a 70-foot height (approximately one wavelength above ground).

Long-wire antennas are subject to precipitation static and static charges during driving rain or snow, and should be disconnected from equipment. Capability for complete disconnect and grounding is essential during thunderstorms. Refer to topics 1, 2, 17, and 44.

Chart 8. Sin and Cos Functions

Degrees	Sin	Cos
10.0	.174	.985
10.5	.182	.983
11.0	.191	.982
11.5	.199	.980
12.0	.208	.978
12.5	.216	.976
13.0	.225	.974
13.5	.233	.972
14.0	.242	.970
14.5	.250	.968
15.0	.259	.966
15.5	.267	.964
16.0	.276	.961
16.5	.284	.959
17.0	.292	.956
17.5	.301	.954
18.0	.309	.951
18.5	.317	.948
19.0	.326	.946
19.5	.334	.943
20.0	.342	.940
21.0	.358	.934
22.0	.375	.927
23.0	.391	.920
24.0	.407	.914
25.0	.423	.906
26.0	.438	.899
27.0	.454	.891
28.0	.469	.883
29.0	.485	.875
30.0	.500	.866
35.0	.574	.819
40.0	.643	.766
45.0	.707	.707
50.0	.766	.643

52 — Long Horizontal Vee-Beam Antenna, Two Bander

The long vee-beam antenna is attractive for use on two bands (particularly 10 and 15 or 15 and 20). Only a matching balun is required. No tuner is necessary when using a proper leg length.

The example of Fig. 70 demonstrates this possibility. In topic 51 a 10-meter leg length corresponding to $39/4$ wavelengths was employed. It is to be noted that a leg length of $29/4$ wavelengths cut for 15-meter operation is approximately the same. Leg length is:

$$(15) \text{ Leg length} = \frac{7134}{21.3} = 334.9 \text{ feet}$$

Note how closely this corresponds to the physical length for 10-meter operation in topic 51. Hence the practical leg length of 329 feet permits two-band operation. The recommended angle for the 15-meter cut is 37° . In the practical case a compromise angle of 34° was employed.

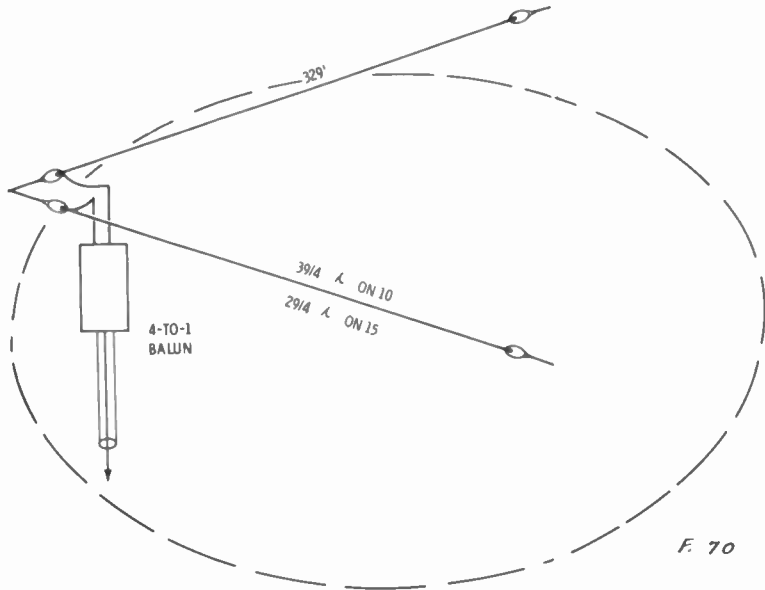

Fig. 70. Two-band long vee beam.

The separation between the leg ends is:

$$d = 2A = 2(329 \times 0.292) = 192 \text{ feet}$$

An attractive formula length for 15- and 20-meter operation is based on $31/4$ for 15 meters and $21/4$ for 20 meters.

$$(15) \text{ Leg length} = \frac{7626}{21.3} = 358 \text{ feet}$$

$$(20) \text{ Leg length} = \frac{5166}{14.3} = 361 \text{ feet}$$

Cut your leg wires 2 percent shorter than 360 feet and trim back to obtain desired resonances. Use a compromise angle of 38° . Refer to topics 1, 2, 17, 44, 45, and 51.

53 — 10-15-20 Vee Beam With Line Tuner

A line tuner in conjunction with a long horizontal vee beam can bring the standing-wave ratio down to a very low value over an entire band (c-w and phone portions). Furthermore the antenna can be operated on lower frequency bands as well.

For example, the antenna of Fig. 70 operates well without a tuner over the sideband segments of the 10- and 15-meter bands. The use of a tuner permits optimum matching to a transmitter on other segments of the two bands.

This antenna also functions with a low standing-wave ratio at the low end of the 20-meter c-w band. The addition of a line tuner permits the antenna to be operated over the entire 20-meter band.

The length of the antenna legs are such that they operate as electrical $19/4$ wavelengths on 20 meters:

$$(20) \text{ Leg length} = \frac{4674}{14.25} = 328 \text{ feet}$$

The recommended angle for this length is 46° which is greater than that used in the antenna of Fig. 70. Nevertheless reasonable performance can be expected because of the broader main lobe.

The tuner can be positioned at the transmitter or just below the feed point of the antenna (Fig. 71). In the latter arrangement, a 45-foot length of coaxial line can be connected between the feed point and the tuner, thus permitting the tuner to be mounted at the base of the mast. The tuner at this point minimizes the loss on the transmission line that must run between the tuner and the transmitter. This is particularly the case when the length of the line is very long. A disadvantage of the plan is the fact that retuning is necessary when changing bands or tuning from one end of the band to the other. Also a weatherproof housing is necessary. Refer to topics 1, 2, 17, 44, 51, and 52.

54 — Multiband Vee-Beam Antenna With Antenna Tuner

The long horizontal vee-beam antenna, when loaded properly, also functions well on lower frequencies, because of the long length of its legs. An antenna tuner (Fig. 72) attached to the antenna of topic 52 can provide loading on 20, 40, and 80 using the relatively simple tuner described in Appendix VII.

The tuner acts as an unbalanced-to-balanced transformer which matches the low impedance of a coaxial transmission line to the

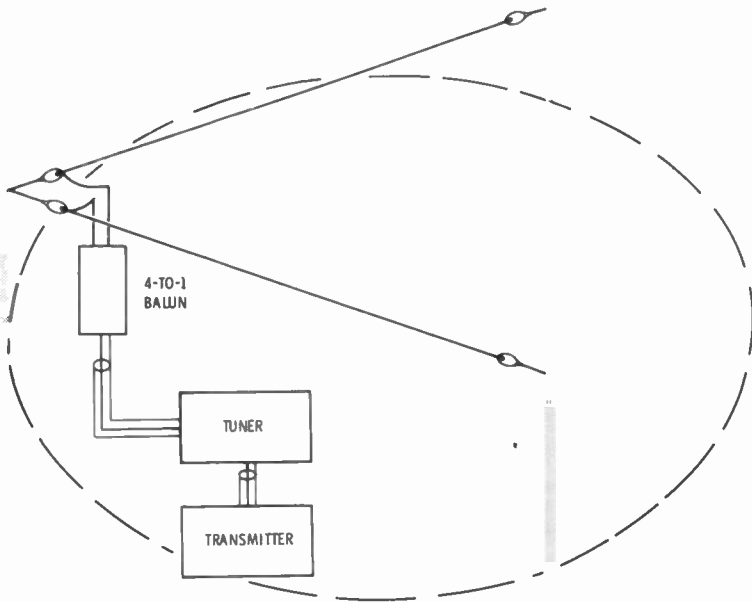

(A) Tuner at the transmitter.

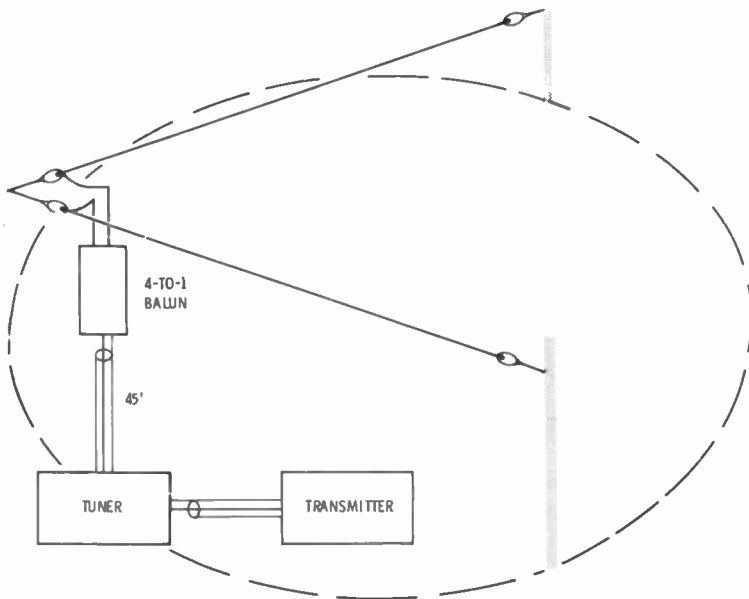

(B) Tuner at base of mast.

Fig. 71. Use of line tuner with vee-beam antenna.

somewhat higher impedance of a long-wire antenna. Such a tuner can be mounted in a weatherproof box at the base of the mast. A 50-foot section of open-wire 450-ohm line links the feed point of the vee antenna to the balanced output side of the tuner (Fig. 72). Coaxial line between tuner and transmitter is made a whole multiple of an electrical half wavelength. Refer to topics 1, 2, 17, 31, 52, and 53.

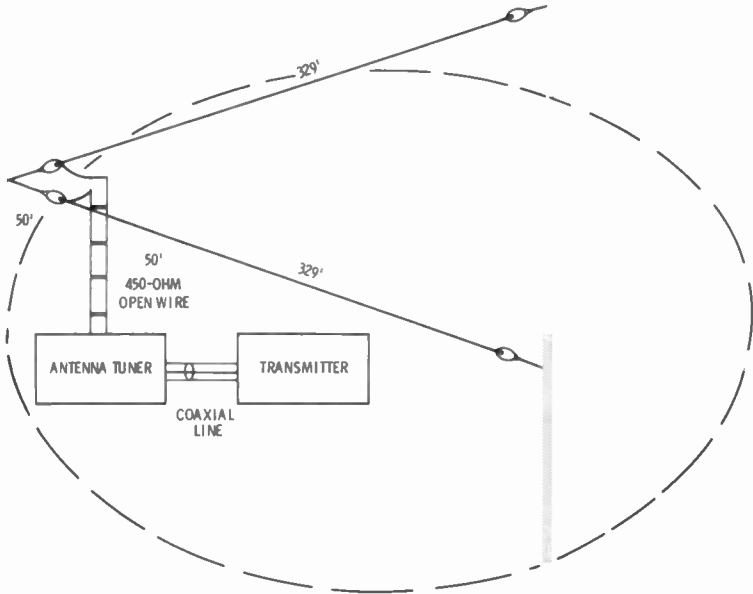

Fig. 72. Use of antenna tuner with vee-beam antenna.

55 — Sloping Vee Beam

A sloping vee-beam antenna is a modified version of the horizontal vee beam in which the far wire ends are nearer ground level than the feed point (Fig. 73). As compared to the horizontal vee beam, there is somewhat less gain at the maximum-gain frequency but a more uniform gain over a wider span of frequencies. Furthermore the legs slope toward ground, which permits a simple far-end mast, or support structure, and greater ease in making antenna resonance and angle changes. Furthermore with adequate space and proper positioning of several fence posts, it is possible to orient the antenna for maximum gain in a number of preferred directions.

Dimensions are given for the 10- and 15-meter two-band antenna of topic 52. Note that the ends of the two vee wires can be kept at a desired height above ground by using an appropriate length of plastic clothesline (nonmetallic core) between the insulator and the fence posts. Slope angles of 5° to 10° are employed. Refer to topics 1, 2, 17, 44, 51, and 52.

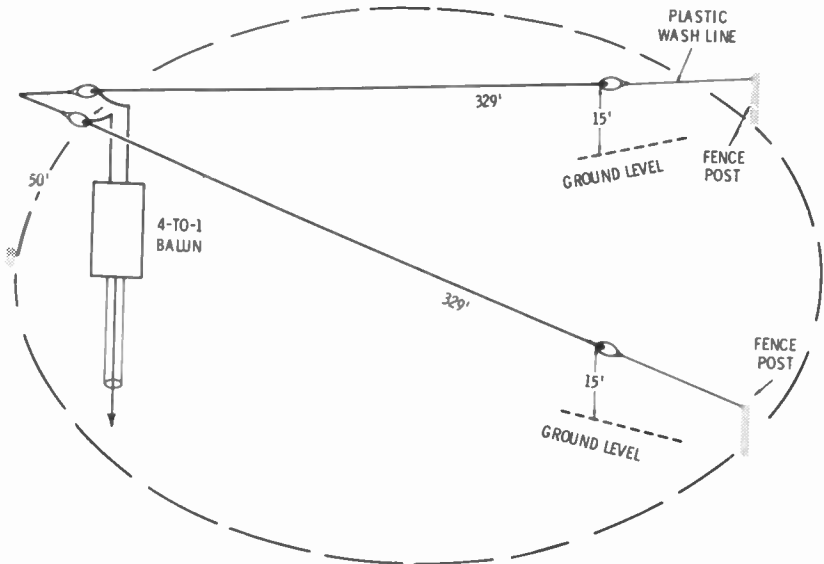

Fig. 73. Sloping vee-beam antenna.

56 — 10-15-20 Sloping Vee Beam

Space permitting, the long vee beam is a fine DX antenna. A single antenna can provide optimum operation on the three popular DX bands. Furthermore, this operation can be accomplished without the use of a tuner, which is a definite inconvenience in changing frequency of operation and bands. You can use one of two approaches in obtaining three-band facility.

If only a single pair of antenna wires is to be employed, these can be end-tuned as shown in Fig. 74. Dimensions for 10- and 15-meter operation are the same as those given in Fig. 70. Formula length for 20-meter operation as a $19/4$ -wavelength antenna is:

$$(20) \text{ Leg length} = \frac{4674}{14.25} = 328 \text{ feet}$$

Practical length was found to be 322 feet. Optimum angle for

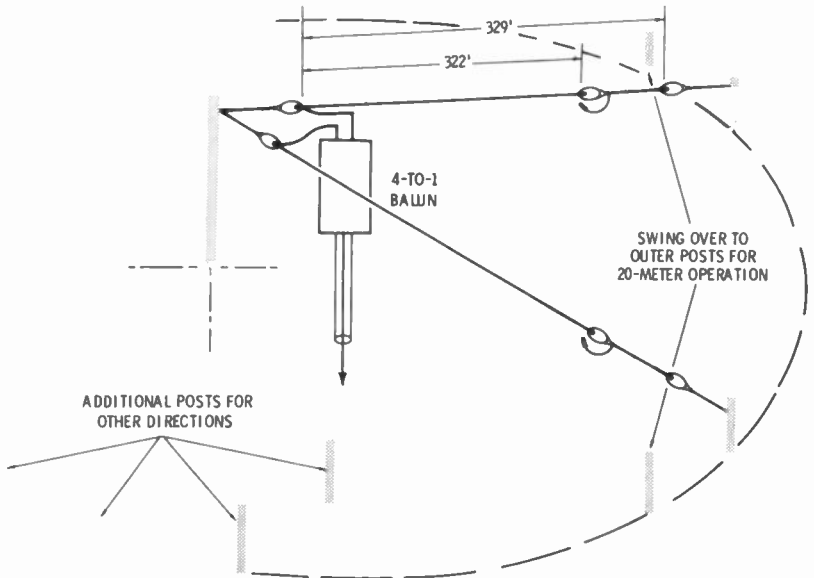

Fig. 74. 10-15-20 sloping end-loaded vee beam.

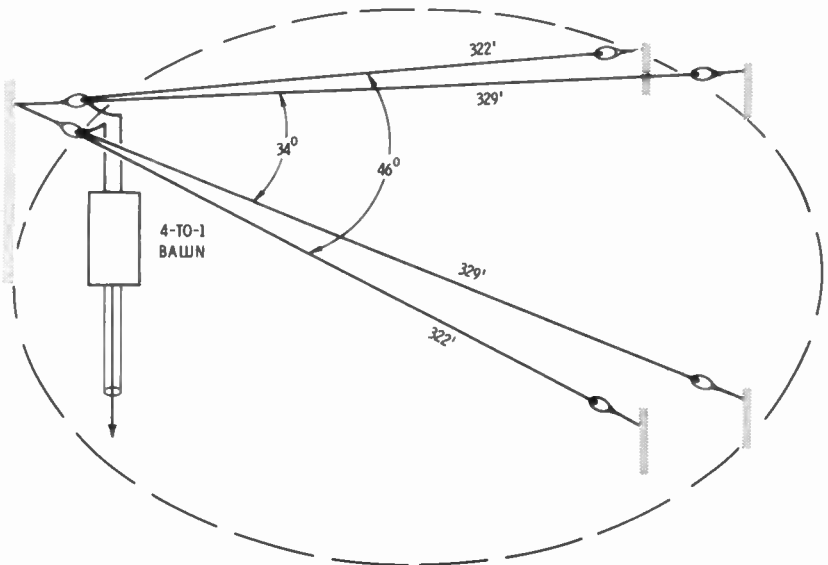

Fig. 75. 10-15-20 four-wire sloping vee beam.

20-meter operation of a long vee antenna of this length is 46° . To obtain this angle the separation between the end wires should be:

$$d = 2A = 2(\sin 23^\circ \times 322) = 252 \text{ feet}$$

Four separate fence posts can be driven into the ground at appropriate distances. The inner two are used for 10- and 15-meter operation with the insulator jumpers closed. For 20-meter operation, the two antenna wire's ends are connected to the outer posts, and the jumpers are operated in the open position. Don't forget that additional posts in other positions permit you to orient the vee beam in other directions.

An alternative plan using two pairs of wire is shown in Fig. 75. This arrangement provides sideband operation on three bands without any antenna changes and without the use of a tuner.

Three band c-w operation is possible by making appropriate adjustments in the leg length using the equations of this topic and topics 51 and 52. Refer to topics 1, 2, 17, 44, 45, 51, 52, and 55.

SECTION 6

Rhombic Antennas

57 — 10-15 Rhombic Antenna

A rhombic is a diamond-shaped long-wire antenna (Fig. 76). For a given length of antenna wire it has a gain approximately 3 dB higher than a long vee-beam antenna. The space requirements are longer and narrower than are needed for the vee antenna. An additional support mast is required by the rhombic.

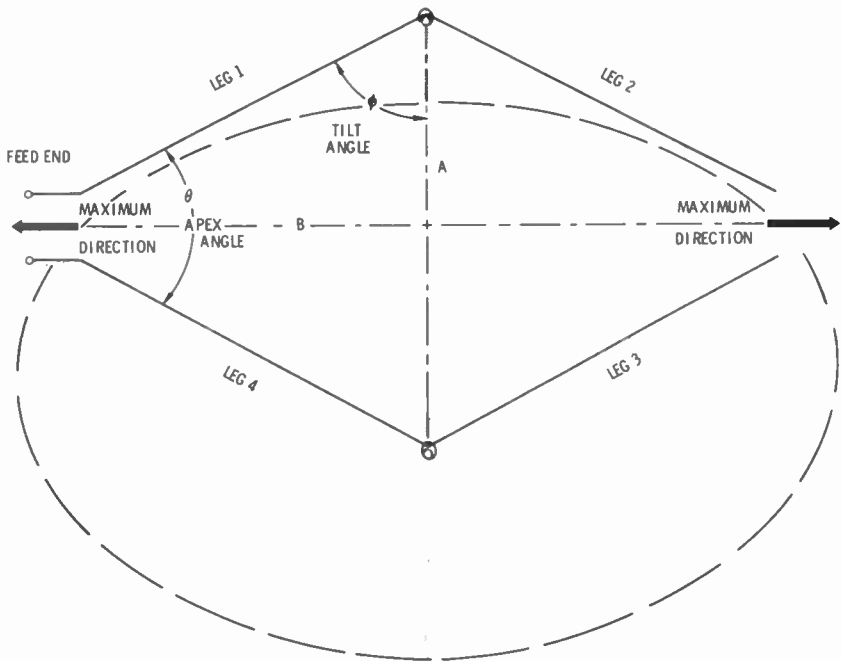

Fig. 76. Resonant rhombic.

Chart 9 relates the antenna leg length to the apex angle and gain. In discussing rhombic antennas the term tilt angle is often used rather than apex angle. These two angles are shown clearly

in Fig. 76. You will note that the tilt angle is that angle made at the side corners of the rhombic. The right triangle set off by the dashed lines indicate that the tilt angle is 90° minus one half of the apex angle:

$$\phi^\circ = 90^\circ - \frac{\theta^\circ}{2}$$

One other angle important to long-wire antennas such as the rhombic is the so-called wave angle. This refers to the vertical angle of radiation of a horizontal antenna relative to the horizontal plane of the antenna. For example 0° wave angle refers to the radiated r-f energy that comes off the antenna in the plane of the antenna. A wave angle of 90° would be the radiation rising perpendicular (at right angles) to the plane of the rhombic. For radio amateur and most communication application for long-wire antennas, the desired wave angles fall somewhere between 0 and 15 degrees. Chart 9 is based on a 0° wave angle.

The preferred apex angle for a rhombic is the same as a vee antenna having the same leg length. It is important to note that the leg length of a rhombic refers to one of the four equal-length sides of a rhombic.

As in the case of a vee-beam antenna or other forms of long-wire antennas, the selection of the proper leg length resonates the antenna in such a manner that a low resistive impedance can be presented at the feed point. The total length of the wire that makes up each of the two sides must be an odd multiple of an electrical quarter wavelength long or:

$$\text{Leg 1} + \text{leg 2} = \text{leg 3} + \text{leg 4} = \text{odd multiple of a quarter wavelength}$$

Chart 9 supplies the necessary information for determining formula leg lengths. The far end of the rhombic antenna wire can then be trimmed to attain a desired resonant frequency. Again by careful choice of leg length, the rhombic, like the vee-beam antenna, can be resonated on more than one band. The antenna can be matched to the coaxial transmission line by means of a balun and no tuning is required. Low standing-wave ratios are feasible. A line tuner can be used at the transmitter if you wish the transmitter to operate into the lowest possible SWR figure.

Chart 9. Rhombic Data Chart

Leg Length in λ	Side Lengths in λ	$L_1 + L_2$ and $L_3 + L_4$	Apex Angle θ	Gain dB
1.125	9/4	2214/f	104°	5.2
1.375	11/4	2706/f	94°	6.5
1.625	13/4	3198/f	86°	7.2
1.875	15/4	3690/f	80°	7.8
2.125	17/4	4182/f	74°	8.3
2.375	19/4	4674/f	70°	8.8
2.625	21/4	5166/f	67°	9.2
2.875	23/4	5658/f	64°	9.6
3.125	25/4	6150/f	61°	10.0
3.375	27/4	6642/f	58°	10.3
3.625	29/4	7134/f	56°	10.6
3.875	31/4	7626/f	54°	10.9
4.125	33/4	8118/f	52°	11.2
4.375	35/4	8610/f	50°	11.4
4.625	37/4	9102/f	49°	11.6
4.875	39/4	9594/f	48°	11.8
5.125	41/4	10086/f	47°	12.0
5.375	43/4	10578/f	46.5°	12.1
5.625	45/4	11070/f	46°	12.2
5.875	47/4	11562/f	45.5°	12.3
6.125	49/4	12054/f	45°	12.35
6.375	51/4	12546/f	44.5°	12.4
6.625	53/4	13038/f	44°	12.45
6.875	55/4	13530/f	43.5°	12.5

The resonant rhombic has a bidirectional pattern (Fig. 76) with maximum lobes in a line bisecting the apex angle. A rhombic can be made unidirectional with a proper termination.

A practical 10- and 15-meter rhombic is shown in Fig. 77. Total side lengths corresponding to 39/4 wavelengths on 10 and 29/4 wavelengths on 15 are approximately the same:

$$(10) \text{ Side length} = \frac{9594}{28.6} \approx 335 \text{ feet}$$

$$(15) \text{ Side length} = \frac{7134}{21.3} \approx 335 \text{ feet}$$

Each rhombic leg is one-half of this value or 167.5 feet. Approximate leg lengths on 10 and 15 are 5 and 3.5 wavelengths respectively. Preferred apex angles for 0° wave angle would be 48° and 56° respectively. A compromise angle of 50° is satisfactory.

The practical resonant lengths for the rhombic erected by the author are given in Fig. 77. Rhombic antenna height was 48 feet.

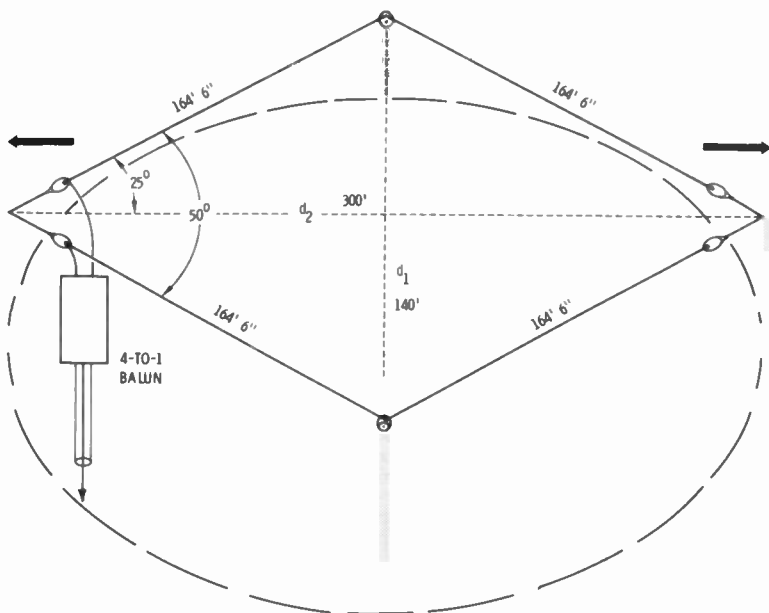

Fig. 77. 10-15 rhombic.

Simple trigonometry can now be used as an aid in locating the poles and determining space requirements. The distance between the side poles is:

$$d_1 = 2(\sin 25^\circ \times 164.5) \approx 140'$$

Distance between the near and end poles is:

$$d_2 = 2(\cos 25^\circ \times 164.5) \approx 300'$$

If additional erection space is available, the formula values of 55/4 on 10 and 41/4 wavelengths on 15 are attractive:

$$(10) \text{ Side length} = \frac{13,530}{28.6} = 473.1 \text{ feet}$$

$$(15) \text{ Side length} = \frac{10,086}{21.3} = 473.5 \text{ feet}$$

These correspond to leg lengths of 6.875 and 5.125 wavelengths for 10 and 15 meters respectively. Preferred apex angles are 43.5° and

47°; a compromise apex angle of 45° is appropriate. Space requirements increase as follow:

$$d_1 = 2(\sin 22.5^\circ \times 236.5) \cong 182'$$

$$d_2 = 2(\cos 22.5^\circ \times 236.5) \cong 440'$$

A 4-to-1 balun is used and the length of the coaxial transmission line to the transmitter is made an odd multiple of an electrical half wavelength. Refer to topics 1, 2, and 52.

58 — 10-15-20 Rhombic With Line Tuner

A line tuner (as per Appendix VI) in conjunction with a rhombic can bring the SWR down to a very low value over an entire band (c-w and phone portions). Furthermore, the antenna can be operated on lower-frequency bands as well.

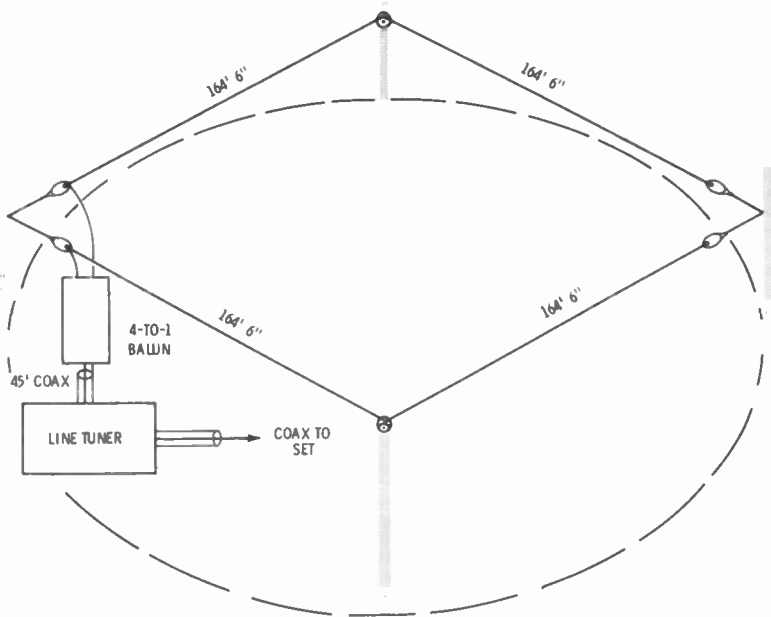

Fig. 78. Rhombic antenna with line tuner.

For example, the antenna of Fig. 77 operates well without a tuner over the sideband segments of the 10- and 15-meter bands. The use of a line tuner permits optimum matching to a trans-

mitter on other segments of the same two bands. This antenna also functions with a low standing-wave ratio at the low end of the 20-meter c-w band. The addition of the line tuner permits the antenna to be operated over the entire 20-meter band (c-w and phone).

The total length of each side of the rhombic (twice the leg length) is such that each side is $19/4$ wavelength on 20 meters.

$$(20) \text{ Side length} = \frac{4674}{14.25} = 328 \text{ feet}$$

The tuner can be positioned at the transmitter or just below the feed point of the antenna (Fig. 78). In the latter arrangement a 45-foot length of coaxial line was connected between the feed point and the tuner, permitting the tuner to be mounted at the base of the mast. This is a good plan because it minimizes the loss on the transmission line that must run between the tuner and the transmitter. A disadvantage of the plan is the fact that retuning is necessary when changing bands or tuning from one end of the band to the other. Also a weatherproof housing is needed. Refer to topics 1, 2, and 57.

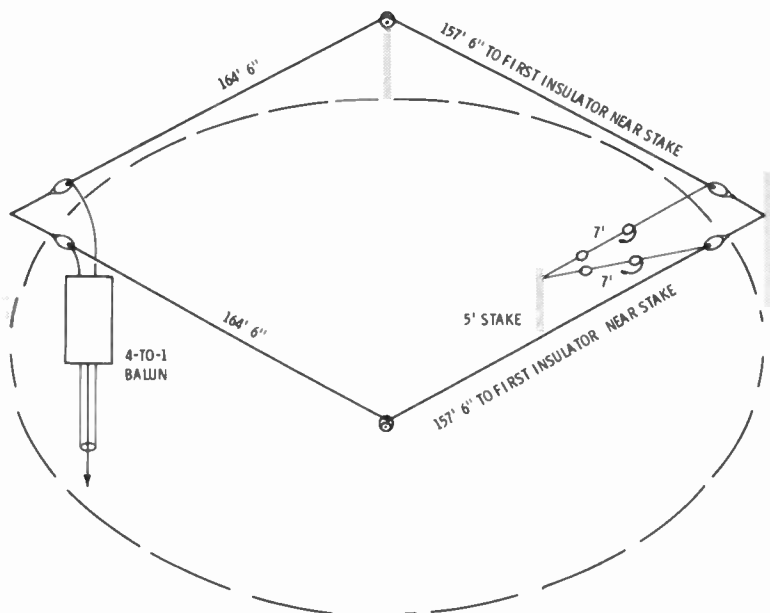

Fig. 79. 10-15-20 end-tuned rhombic.

59 — 10-15-20-40 End-Tuned Rhombic

The rhombic antenna, like the other long-wire types, can be end-tuned using insulators and associated jumpers (Fig. 79). Such multiband operation can be accomplished without the use of a tuner. The basis for the antenna is the 10-15 rhombic of topic 57. Operation on 20 meters is accomplished by using somewhat shorter sides. Formula length for 20-meter operation as a $19/4$ -wavelength antenna is:

$$(20) \text{ Side length} = \frac{4674}{14.25} = 328 \text{ feet}$$

Practical length was found to be 322 feet. The compromise apex angle used is also satisfactory for 20-meter operation. The band-change point is made accessible by bringing the end points down close to ground level as shown in Fig. 79 .

For 40-meter operation an attractive formula value for total side length corresponds to $11/4$ wavelengths:

$$(40) \text{ Side length} = \frac{2706}{7.25} = 373 \text{ feet}$$

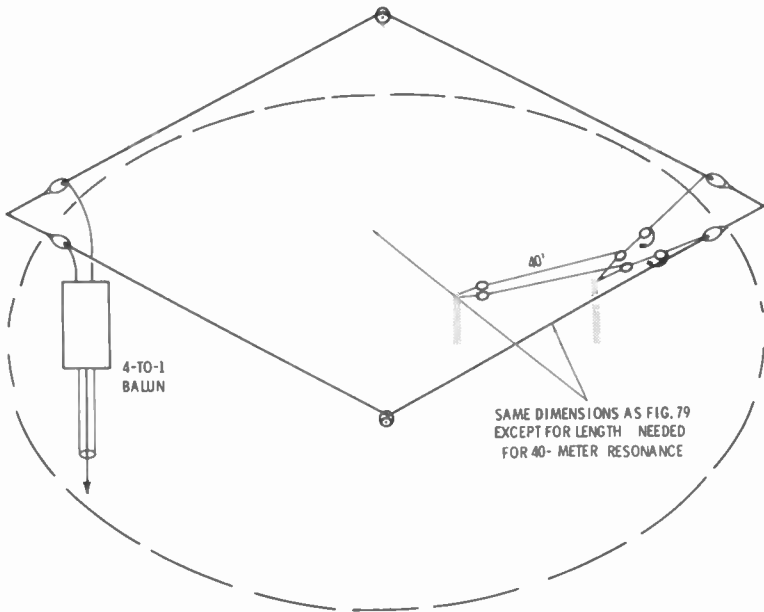

Fig. 80. 10-15-20-40 end-tuned rhombic.

The additional length of line needed to resonate the rhombic on 40 meters can be attached at the termination end where it is brought near to ground level (Fig. 80). An added length of 40 feet does the job. On 40 meters the leg length is just about 1.5 wavelengths and the apex angle is substantially smaller than the recommended value. This raises the wave angle, which is not altogether objectionable for 40-meter operation and general performance is quite good. Refer to topics 1, 2, 35, and 57.

60 — Two-Wire 10-15-20 Rhombic

Two resonant sections, one for 10- and 15-meter operation and the other for 20 meters, can be erected for three-band operation without the use of a tuner. In a practical version of this rhombic idea (Fig. 81), a side length of 329 feet was used for 10- and 15-meter sideband operation, while shorter sides of 322 feet established resonance in the sideband section of 20 meters.

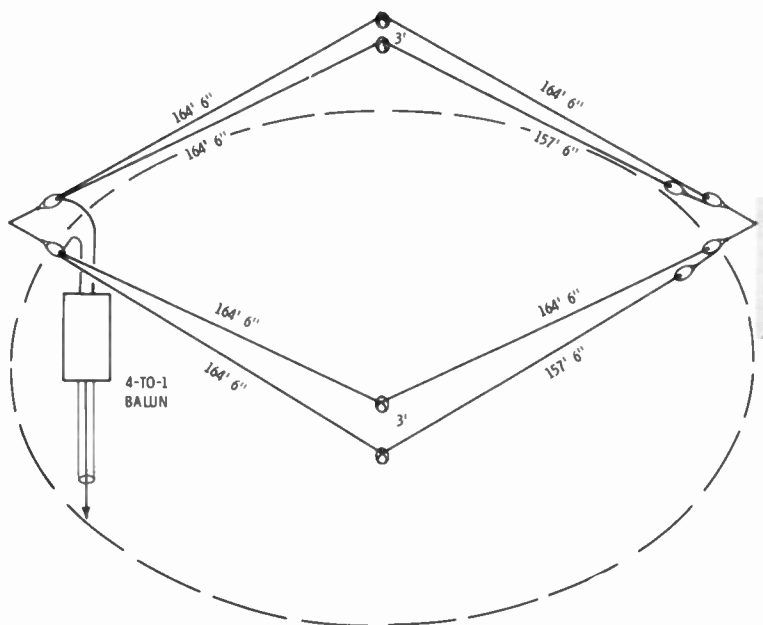

Fig. 81. Two-wire 10-15-20 resonant rhombic.

If desired, the same idea can be used to cut the resonant sides into the c-w portions of the three bands. Refer to topics 1, 2, 47, 57, and 59.

61 — Resonant Rhombic With Tuner and Open-Wire Line

When the length of the transmission line between the rhombic feed point and the transmitter/receiver is more than 135 to 150 feet, it is advisable to employ open-wire transmission line to minimize line loss. More power is delivered to the rhombic, and more signal is delivered to the receiver from a distant station. The 300-ohm and 450-ohm types are readily available. When the line can be brought into the shack, the antenna tuner of Appendix VII is ideal (Fig. 82).

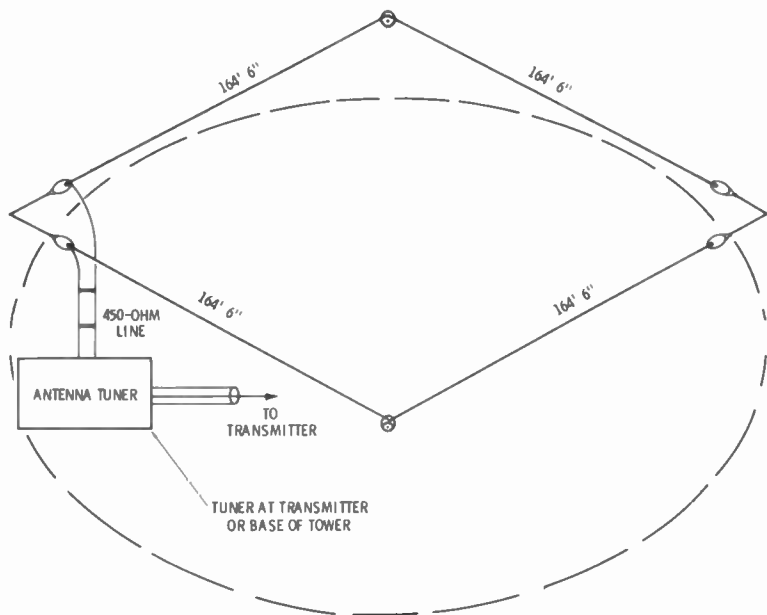

Fig. 82. Rhombic with open-wire line and antenna tuner.

The rhombic antenna when loaded properly also functions well on lower frequencies because of the long length of its legs. Of course, it does not have the sharp directional characteristics present on the higher-frequency bands unless it is made exceptionally long. An antenna tuner is essential.

Open-wire line can also be used to advantage with any of the vee and rhombic antennas when long lengths of transmission line are a necessity. Center-fed long wires can be fed in the same manner.

The antenna tuner of Appendix VII could be mounted in a weatherproof housing at the base of the feed-point mast. A 50-foot section of 450-ohm open-wire line links the rhombic feed point to the tuner. In this latter plan, there is some loss in the coaxial line to the set if the line is very long.

Refer to topics 1, 2, 17, 44, 54, and 57.

62 — Terminated Rhombic

The resonant rhombic is a bidirectional antenna. However the rhombic can be made unidirectional by employing a resistive termination at the far end of the antenna (Fig. 83). The characteristic impedance of the rhombic configuration approximates 800 ohms and if a resistive termination of 800 ohms is placed across the far end, the rhombic itself becomes nonresonant. (This is similar to the termination of a transmission line in its characteristic resistance.)

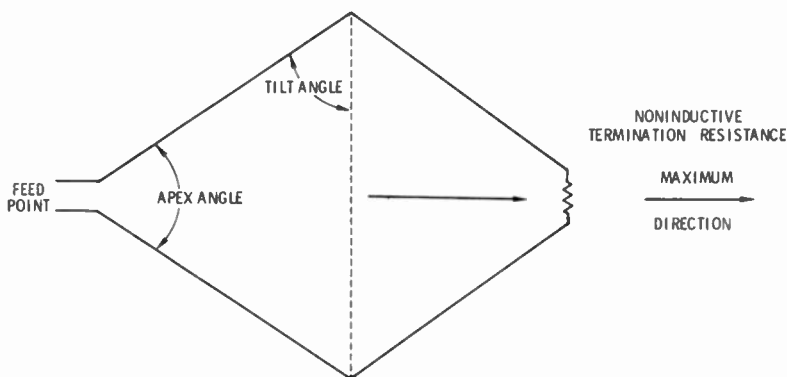

Fig. 83. Basic terminated rhombic.

When the rhombic is terminated properly, the antenna resistance at the feed point also approximates 800 ohms over a wide span of frequencies. The terminated rhombic has maximum directivity along the bisector line extending from the feed point toward the terminated end as shown in Fig. 83.

The termination must be resistive, and noninductive resistors are required. The power that must be dissipated by the resistors approximates one half of the power applied to the input end of the rhombic. For amateur use it is usually economical to employ a network of resistors of low power rating. The network used to terminate the practical rhombic of Fig. 84 consisted of 20 five-watt 600-ohm noninductive resistors connected in a series-parallel

network. The net resistance of the network is 750 ohms. Such a network displays a wattage rating capable of handling 200 watts PEP with no difficulty. In fact, the pulse nature of sideband transmission is such that considerably more power can be handled safely by the network.

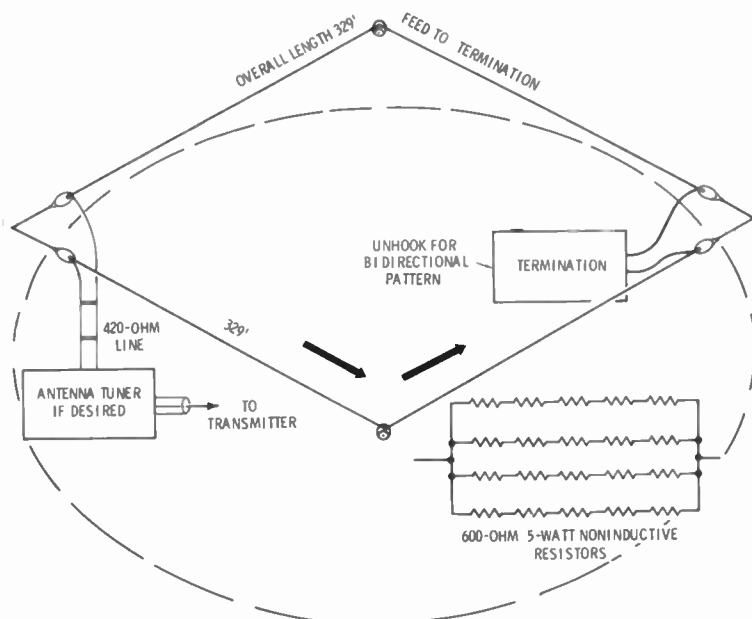

Fig. 84. Practical terminated rhombic.

The terminated rhombic can be fed suitably in a number of ways. A reasonable match is made to the 450-ohm open-wire line. A 50-foot section of this line can connect the rhombic feed point to an antenna tuner mounted at the base of the mast. The alternative plan is to continue the open-wire line from the rhombic feed point to the radio room and some point where the antenna tuner can be mounted conveniently.

Any leg length is permissible provided the appropriate apex angle is employed. An antenna tuner is advisable if you wish to avoid some trimming and you are fussy about SWR. Refer to topics 1, 2, 17, 54, 57, and 61.

SECTION 7

**Very Long
Long-Wire Antennas**

63 — Two-Band Very Long Long-Wire Antennas

The single long-wire antenna properly fed and very long in length is an effective gain antenna and can often be erected in positions where other types of long-wire antennas are not feasible. Length for two-band operation can be attained by calculating samples from dimension Chart 10. Such an antenna also has all-band capabilities if end-tuned. It has a high directivity in the direction of the far end of the wire for the high-frequency bands. Radiation patterns are less directional for the low-frequency bands.

Chart 10. Long Long-Wire Lengths

Length in Wavelengths	Length in Feet
39/4	9594/f
41/4	10086/f
43/4	10578/f
45/4	11070/f
47/4	11562/f
49/4	12054/f
51/4	12546/f
53/4	13038/f
55/4	13530/f
57/4	14022/f
59/4	14514/f
61/4	15006/f
63/4	15498/f
65/4	15990/f
67/4	16482/f
69/4	16974/f
71/4	17466/f
73/4	17958/f
75/4	18450/f
77/4	18942/f
79/4	19434/f
81/4	19926/f
83/4	20418/f
85/4	20910/f
87/4	21402/f

An excellent 10-15 meter combination has an electrical length of $55\frac{1}{4}$ wavelengths on 10 and $41\frac{1}{4}$ wavelengths on 15:

$$(10) \text{ Long-leg length} = \frac{13530}{28.6} = 473.1 \text{ feet}$$

$$(15) \text{ Long-leg length} = \frac{10086}{21.3} = 473.5 \text{ feet}$$

The short sides are calculated from the basic dipole equation:

$$(10) \text{ Short-leg length} = \frac{234}{28.6} = 8.53 \text{ feet}$$

$$(15) \text{ Short-leg length} = \frac{234}{21.3} = 10.98 \text{ feet}$$

Practical dimensions for the antenna are given in Fig. 85. It is wise to cut the very long long-wire antennas eight to ten feet longer than formula value and trim back from this length. A

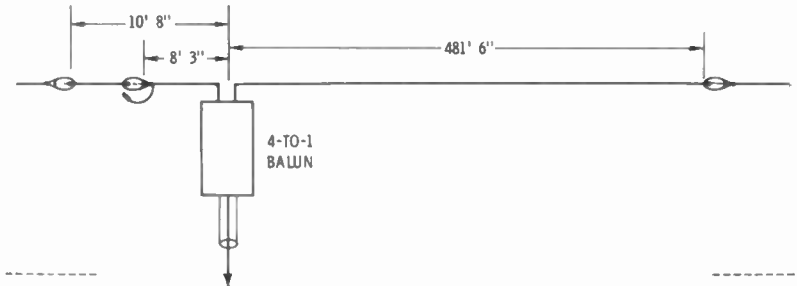

(A) Two-band, 10-15.

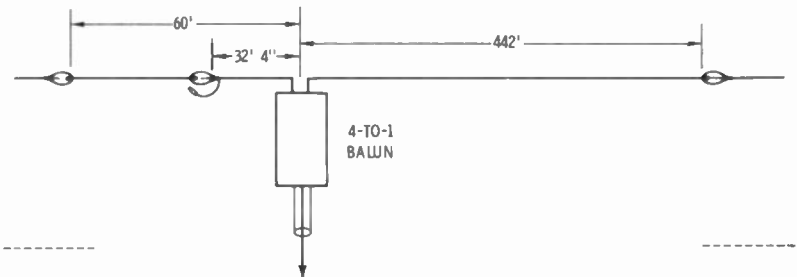

(B) Two-band, 40-80.

Fig. 85. Practical dimensions for two-band very long long-wire antennas.

four-to-one balun is used for matching, and the coaxial transmission line to the transmitter is made a whole multiple of an electrical half wavelength.

A long long-wire antenna can be erected to obtain good directivity in some desired direction for 40- and 80-meter operation. Formula dimensions for $14\frac{1}{4}$ wavelengths and $7\frac{1}{4}$ wavelengths for 40 and 80 meters respectively are attractive:

$$(40) \text{ Long-leg length} = \frac{3198}{7.25} = 441 \text{ feet}$$

$$(80) \text{ Long-leg length} = \frac{1722}{3.9} = 441 \text{ feet}$$

The shorter leg lengths are:

$$(40) \text{ Short-leg length} = \frac{234}{7.25} = 32.3 \text{ feet}$$

$$(80) \text{ Short-leg length} = \frac{234}{3.9} = 60 \text{ feet}$$

Again practical dimensions are given in Fig. 85.

An attractive 20- and 40-meter length is a $21\frac{1}{4}$ - and $41\frac{1}{4}$ -wavelength combination:

$$(20) \text{ Long-leg length} = \frac{10086}{14.2} = 710 \text{ feet}$$

$$(40) \text{ Long-leg length} = \frac{5166}{7.25} = 712 \text{ feet}$$

Other two-band combinations can be found by sampling the length equations. Refer to topics 1, 2, 17, 33, and 34.

64 — End-Tuned Very Long 5 DXCC Long Wire

The very long long-wire antenna can also be segmented to permit operation on other bands. The addition of a pair of insulators and associated jumpers can add 20-meter operation to the basic 10- and 15-meter antenna of topic 63.

Formula value for $27\frac{1}{4}$ wavelengths on 20 is:

$$(20) \text{ Long-leg length} = \frac{6642}{14.2} = 468 \text{ feet}$$

The long leg can be broken as shown in Fig. 86. A 20-meter short-leg segment must also be added. However the far end jumper need only be changed when making a changeover between 10- and 15- or 20-meter operation.

If an SWR no greater than 2.5 to 1 is tolerable on 20 meter side-band (lower on c-w), the long-leg length as used for 10- and 15-meter operation can also be used on 20. In this case only the short near-end jumper need be changed. The 40- and 80-meter bands can also be added to permit five-band capability. A line tuner can be used to further reduce the SWR at the transmitter if desired.

Formula calculations indicate a cluster of resonant lengths for all seven bands for a long-leg length of approximately 700 feet. The end of the long leg is brought down rather sharply from the end support mast for convenient band changes, permitting the bulk of the long leg to be kept high and clear as is advisable for good low-angle radiation.

Formula values are:

$$(10) \text{ Long-leg length} = \frac{20418}{28.6} = 713 \text{ feet}$$

$$(15) \text{ Long-leg length} = \frac{10086}{21.3} = 710 \text{ feet}$$

$$(20) \text{ Long-leg length} = \frac{9594}{14.2} = 675 \text{ feet}$$

$$(40) \text{ Long-leg length} = \frac{5166}{7.25} = 712 \text{ feet}$$

$$(80) \text{ Long-leg length} = \frac{2706}{3.9} = 694 \text{ feet}$$

$$(160) \text{ Long-leg length} = \frac{1230}{1.825} = 673 \text{ feet}$$

It should be noted that for 10-, 15-, and 40-meter operation, the lengths are approximately the same, and one end-tuning position handles these three bands. Likewise 20- and 160-meter resonances are about the same and only one length is needed. A separate length is required for 80 meters. It should also be noted that there is a 10-meter resonance near the 80-meter length.

$$(10) \text{ Long-leg length} = \frac{19926}{28.6} = 696 \text{ feet}$$

This length provides both 10- and 80-meter resonance. Refer to topics 1, 2, 17, 33, 34, 36, and 63.

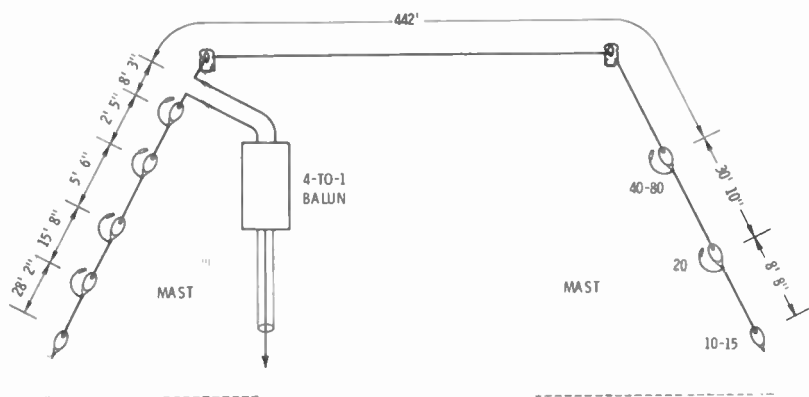

Fig. 86. End-tuned very-long wire.

65 — 5 DXCC Long-Wire Special

The 5 DXCC long-wire special consists of three individual long wires that permit five-band operation (10 through 80) without making any changes in the long wires once they are trimmed to resonance. The three long legs (Fig. 87) can be mounted high and clear in a permanent position because far-end switching is not necessary. The short quarter-wave legs can be mounted low and accessible for convenient band change.

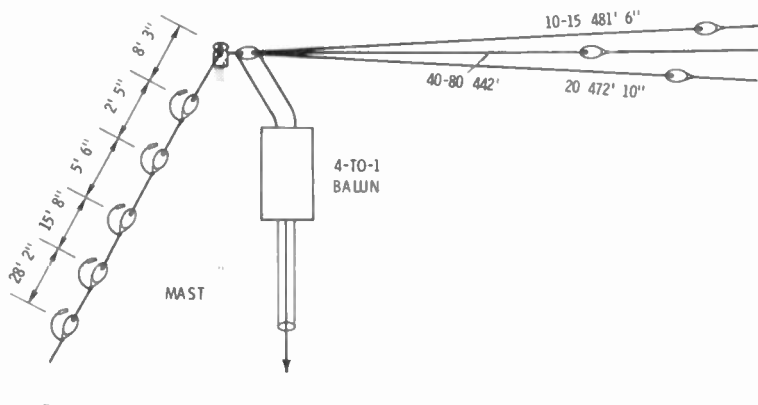

Fig. 87. Long-wire 5DXCC special.

High mounting of the long legs provides a low vertical angle for good DXing—wonderful, if you can get up 70 feet. The multiple lobes provide good omnidirectional results, and at the same time there is an exceptional performance peak off the far ends.

Dimensions of a practical antenna (Fig. 87) were established using the formula values calculated previously for the long-wire antennas of topics 63 and 64. Three such long-wires permit operation on five bands without the use of a tuner. Refer to topics 1, 2, 17, 44, 63, and 64.

66 — All-Band, 6-160 End-Fed Very Long Wire With Tuner

A very-long antenna wire in conjunction with the tuner of Appendix VI modified for 40-, 80-, and 160-meter end-feed use as in Fig. 88 permits you to use a long-wire antenna of a maximum

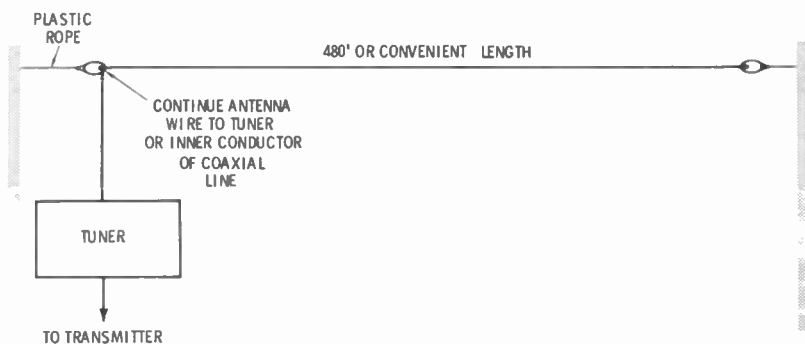

(B) Long-wire dimensions.

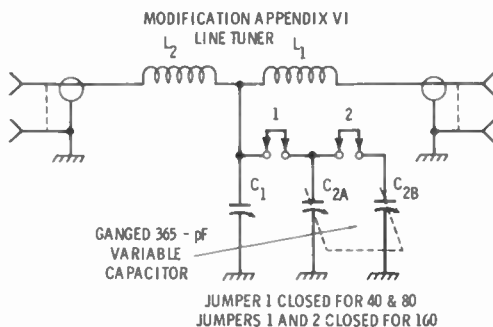

(A) Tuner modification.

Fig. 88. Convenient very-long wire length.

length that can be accommodated on your property. The longer the wire is, the more directive the antenna becomes, and the higher is the antenna gain off the far end of the antenna wires. The directivity and gain is at a maximum on the highest-frequency band.

In DX communications the higher the antenna is, the greater is the radiation at low wave angles. Thus one should attempt to keep most of the antenna as high as possible.

The transmitter end of the long-wire antenna can be brought directly into the shack. Of course, this part of the antenna should be insulated to prevent shorting to metallic surfaces. As mentioned early in the book, the antenna wire itself can be covered

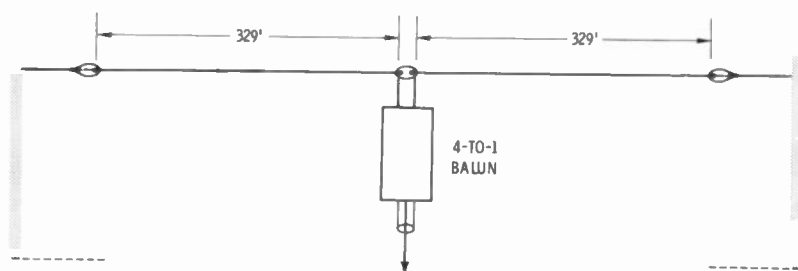

(A) 10-15 meters.

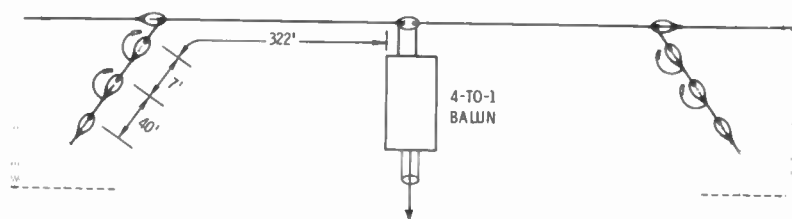

(B) 10-15-20 or 10-15-20-40, end-tuned.

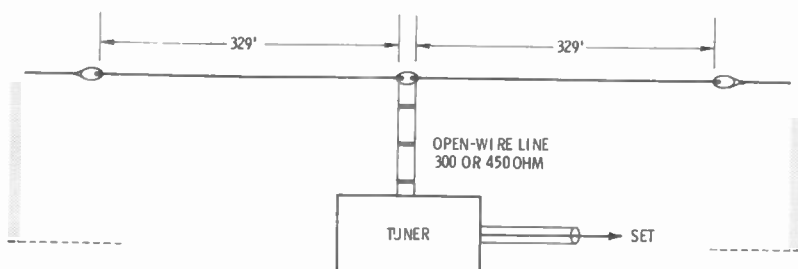

(C) Open-wire line with tuner.

Fig. 89. Bidirectional center-fed long wires.

with insulation as a safety feature. Such insulation does not have any adverse influence on the antenna radiation. Refer to topics 1, 2, 31, 33, 34, 35, 36, 63, 63, 65, and 66.

67 — Long-Path Short-Path Long-Wire Antenna

The center-fed long-wire antenna is bidirectional off its far ends. The longer the antenna, the sharper is the bidirectional pattern and the higher is the antenna gain off the ends. Such a bidirectional antenna pattern is advantageous in those sites where the preponderance of contacts are from two opposite directions. Furthermore the bidirectional antenna can provide both long-path and short-path communications by way of the same fixed-position antenna.

Three possible arrangements are shown in Fig. 89. For operation on 10 and 15 meters alone, a dimension can be selected that permits two-band operation. A four-to-one balun and coaxial transmission line can be used. If other bands are to be added, the antenna can be end-tuned. Bring each of the legs down sharply from the end support masts to make band changing convenient. The 10-15-20 and 10-15-20-40 combinations are shown.

If a long length of transmission line is necessary, the use of open-wire line minimizes line attenuation. A tuner (Appendix VII) is recommended and permits the antenna to be used on all frequencies in all bands. Such an antenna also performs well on 160 meters. An ideal tuner for 160-meter operation has been detailed by Lewis G. McCoy in May 1969 *QST*. In fact, coaxial line can be run from the outdoor end of a long-wire antenna to the transmitter. The grounded braid of the coaxial line helps to keep rf out of the shack, often a problem with random end-fed wires. Refer to topics 1, 2, 17, 32, 54, 61, 62, and 63.

SECTION 8

Special Vees and Rhombics

68 — 160-Meter Two-Mast Inverted Vee

Three factors of concern in the erection of a 160-meter antenna are space requirement, noise pickup, and local-DX capability. Generally the half-wavelength horizontal antenna is quieter and less subject to noise pickup as compared to the vertical. Furthermore a good ground system is very important to the operation of a vertical antenna. Long-haul DX contacts usually favor the verticals. At times the reception of DX stations is better on a horizontal. Better reliability is usually obtained with the long horizontal antenna for medium distances, while strictly local contacts are often more favorable with a good vertical.

The two-mast inverted-vee antenna is a compromise arrangement capable of accommodating an antenna with a full half-wavelength dimension in a shorter space. Furthermore the use

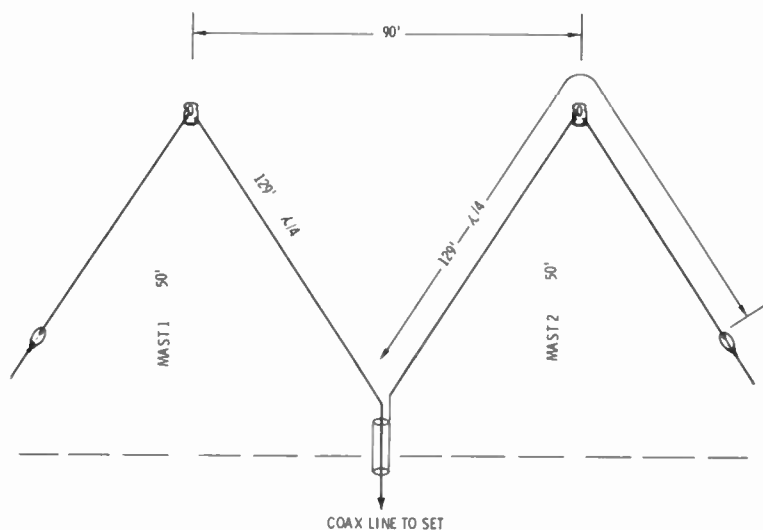

Fig. 90. Two-mast inverted vee for 160.

of two masts permits the wires to have a significant vertical slope (Fig. 90).

Leg length corresponds to a quarter wavelength on 1.81 MHz. Coaxial transmission line can be used to feed the antenna and a good SWR is obtainable between 1.8 and 1.85 MHz. Some length adjustment may be necessary to set resonance at a desired frequency.

If the transmission line run is very long an open-wire line and 160-meter antenna tuner can be used. Also in conjunction with the antenna tuner of Appendix VII, multiband operation as a center-fed long wire is feasible. It has some of the characteristics of the inverted vee and does display some end directivity on the 10-, 15-, and 20-meter bands. Refer to topics 1, 2, 17, 22, 39, 61, and 67.

69 — 10-160 End-Tuned Two-Mast Inverted Vee

The two-mast inverted-vee construction also lends itself to end feed. Segments of antenna wire can be added to the basic 160-meter arrangement of topic 68 as shown in Fig. 91. Formula dimensions work out as follows:

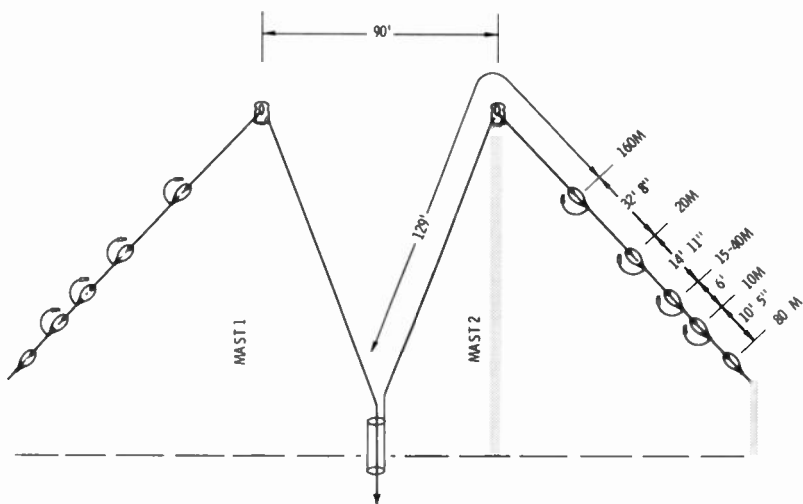

Fig. 91. Two-mast end-tuned inverted vee.

$$(80) \text{ Leg length} = \frac{738}{3.8} = 194 \text{ feet}$$

$$(40) \text{ Leg length} = \frac{1230}{7.2} = 170 \text{ feet}$$

$$(20) \text{ Leg length} = \frac{2214}{14.2} = 156 \text{ feet}$$

$$(15) \text{ Leg length} = \frac{3690}{21.3} = 173 \text{ feet}$$

$$(10) \text{ Leg length} = \frac{5166}{28.6} = 180 \text{ feet}$$

These lengths have to be trimmed to find the desired resonance point. Practical dimensions for the model erected by the author are given in Fig. 91. A coaxial transmission line that is a compromise whole multiple of an electrical wavelength was used (approximately 135 feet). Refer to topics 1, 2, 17, 18, 19, 24, and 68.

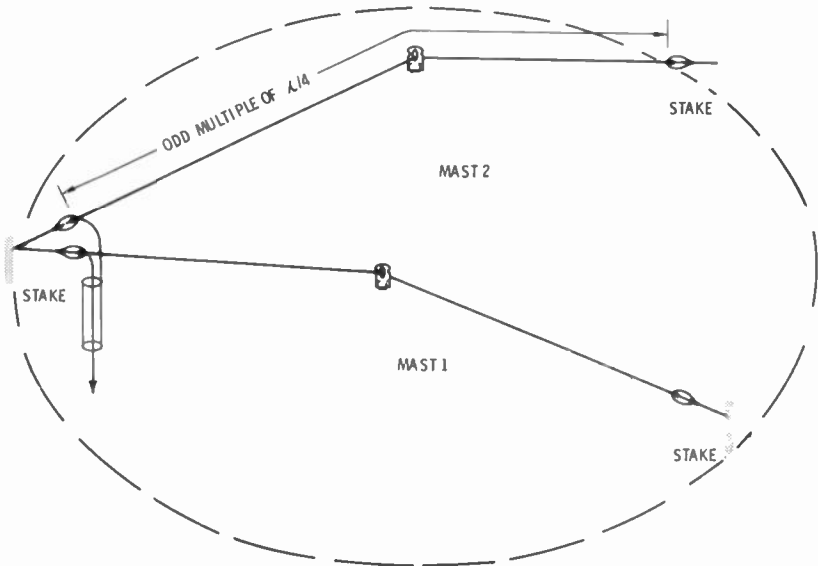

Fig. 92. General plan of two-mast vee beam.

70 — Two-Mast Vee-Beam

The legs of a two-mast inverted vee can be tilted forward to form a vee-beam antenna as in Fig. 92. The mast is located at the approximate center of each leg and the leg wires slant down toward the feed point and toward the antenna wire ends in inverted-vee fashion. Ordinarily the vee-beam antenna requires three masts.

An apex angle is selected in accordance with the number of wavelengths on each leg as per Charts 6 and 7. The feed point is brought down to a level where it becomes accessible for convenient changes. Likewise the antenna wire ends are brought down and made convenient for end tuning.

A practical version of this antenna using the dimensions of topic 69 was constructed as shown in Fig. 93. A compromise angle of 60° was selected for multiband operation. Somewhat better low-band performance can be obtained by increasing this angle up to approximately 90° . Directivity is still good on 10 and 15.

Dimensions for end tuning are given in Fig. 93A. For long lengths of transmission line an open-wire line and tuner are recommended as shown in Fig. 93B. The tuner of Appendix VII is ideal for 10- through 80-meter operation. Refer to topics 1, 2, 17, 44, 51, 54, 68, and 69.

71 — Three- and Four-Mast Switchable Vee Beams

The vee-beam construction of topic 70 can be used to advantage in the construction of a switchable vee beam because the feed point and the wire ends can be brought down to a level that is accessible. At the feed point it is then convenient to connect the transmission line to any pair of antenna wires in accordance with the desired orientation of the beam.

In the three-mast arrangement of Fig. 94A the three masts are mounted in a triangle. They are spaced equidistantly from each other and separated from the center of the triangle by approximately half the distance of the antenna leg length. Therefore the separation between antenna wires is 120° which angle also becomes the apex angle of the vee-beam. By attaching the transmission line to the correct pair of antenna wires there is a choice of three directions of maximum radiation, spaced 120° apart. Mount the three antenna masts so that these maxima fall at the most favorable compass angles. Recognize that the angles of the maxima fall midway between the angular positions of the mast.

If coaxial transmission line is to be used the antenna wires can be end-tuned, and the feed point can consist of three coaxial connectors as shown in Fig. 94A. Use dimensions of Fig. 93 if desired. One need only connect the coaxial line to the appropriate connector to select the desired pair of antenna wires. The antenna wires can be terminated in a set of three insulators when open-wire line and antenna tuner are employed. The open-wire line is connected to the preferred pair of antenna wires. This latter arrangement also permits coaxial feed via a 4-to-1 balun.

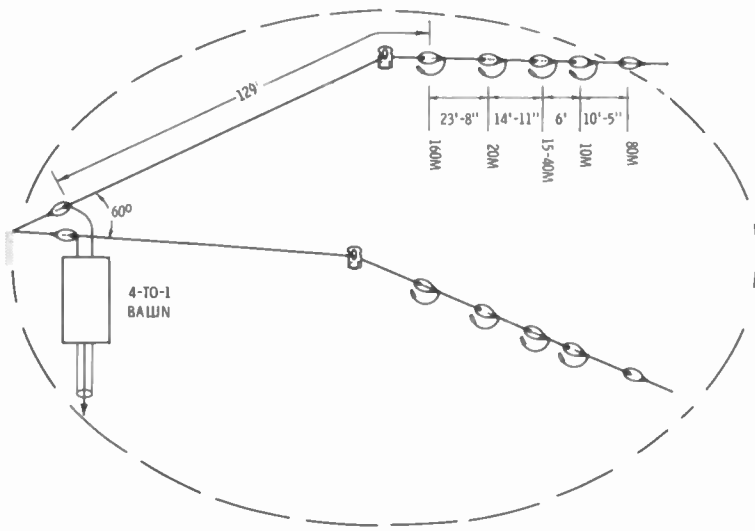

(A)

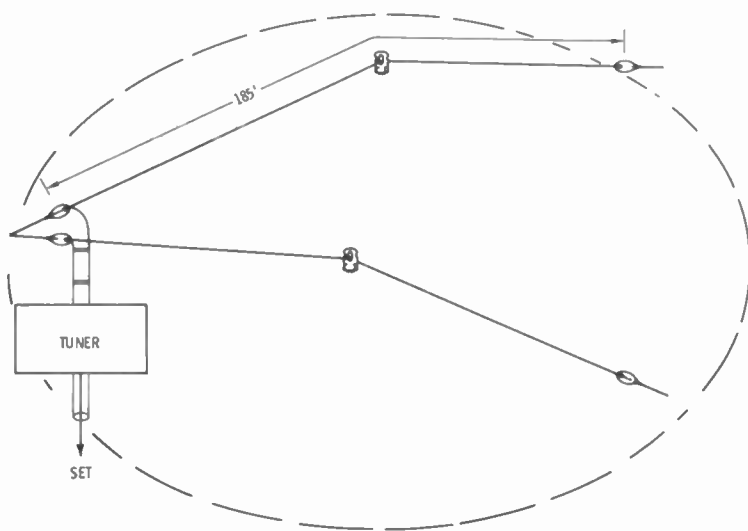

(B)

Fig. 93. Two-mast end-tuned vee beam.

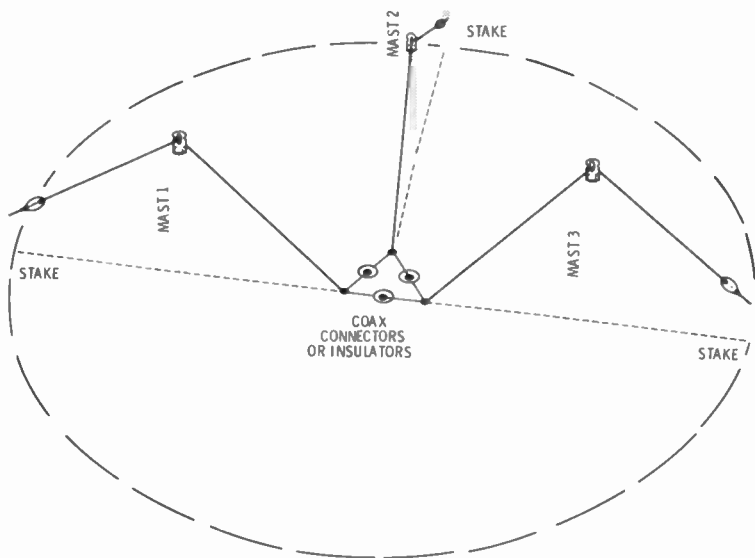

(A) Three mast.

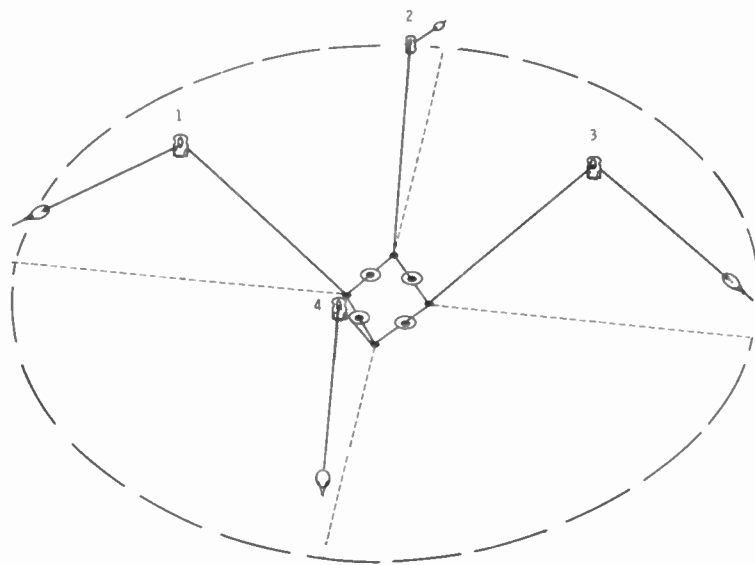

(B) Four mast.

Fig. 94. Switchable vee beams.

Four masts mounted in a square is a more versatile construction. The four antenna wires of such a combination are spaced 90°, which is a more favorable angle for vee-beam operation on the DX bands. As shown in Fig. 94B you now have four maximum directions available to you by selecting the appropriate pair of adjacent antenna wires. These pairs are 1 and 2, 2 and 3, 3 and 4, plus 4 and 1. Two center-fed long-wire combinations are also possible using antenna wires 1 and 3 or 2 and 4. Feed arrangement is the same as that of the three-mast plan except that four coaxial connectors or insulators are employed. Two additional insulators or connectors (from 1 to 3 and 2 to 4) are needed if you wish to take advantage of the center-fed long-wire pairs. Refer to topics 1, 2, 17, 44, 51, 54, 67, 68, 69, and 70.

72 — Two-Mast Rhombic

By tilting down the feed end and far end of a rhombic antenna in inverted-vee fashion only two center masts are needed for erection (Fig. 95). The feed point can then be made accessible for transmission-line changes and, if desired, for the direct attachment of an antenna tuner. The far end is also readily accessible and

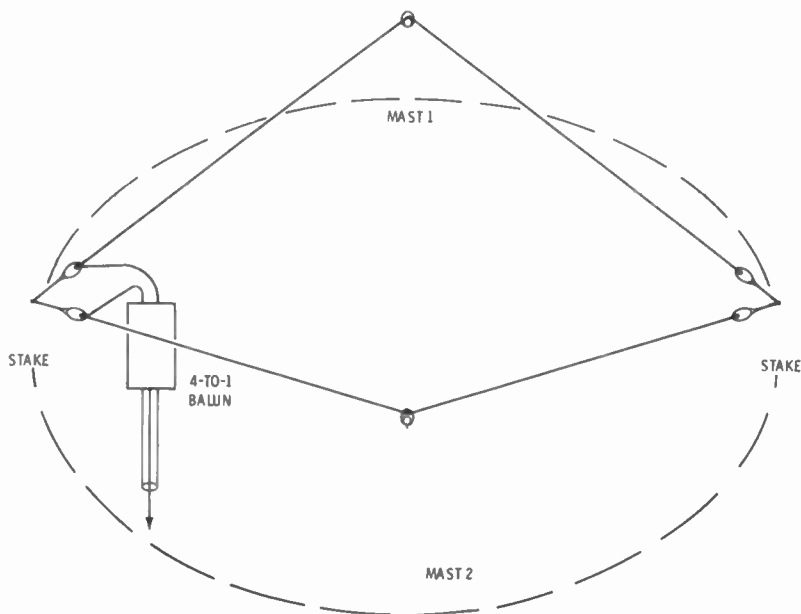

Fig. 95. General plan of a two-mast rhombic.

made quite convenient for switching over between open bidirectional and terminated unidirectional operation of the antenna. Of course, bringing the far end to a low level makes it convenient for end-tuning of the rhombic.

The practical short rhombic of Fig. 96 was compromised from the dimensions developed in topics 69 and 70. Unless the feed point can be located rather near to the transmitter, the use of open-wire transmission line and an antenna tuner is recommended for getting the most out of the short rhombic. With a 45-foot mast height, this antenna worked into all continents with ease. Its performance surpassed a three-element beam on 10 meters and equaled a two-element beam on 15. Also the antenna gives you low-band operating capability, including 160 meters.

The same idea can be used to construct a long rhombic antenna using the dimension information given in topics 57 through 63. Refer to topics 1, 2, 17, 57, 58, 59, 60, 61, 62, 63, 69, 70, and 71.

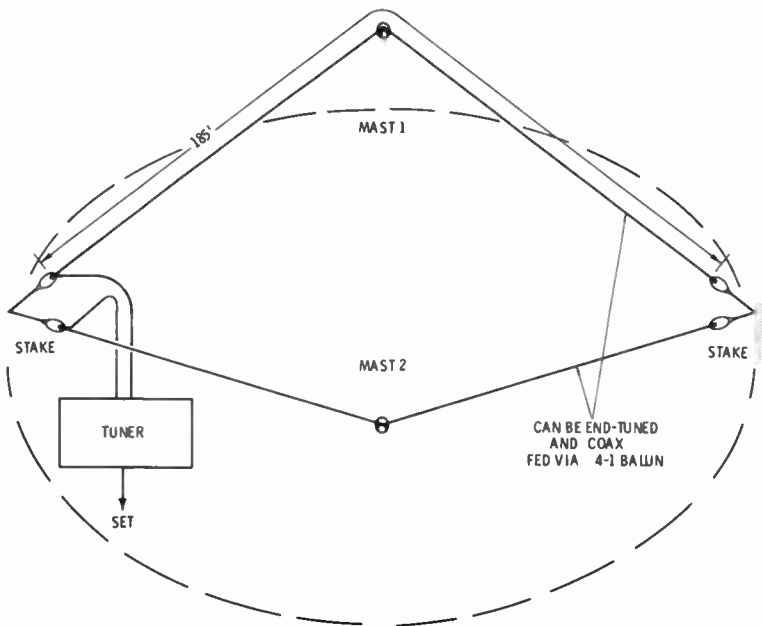
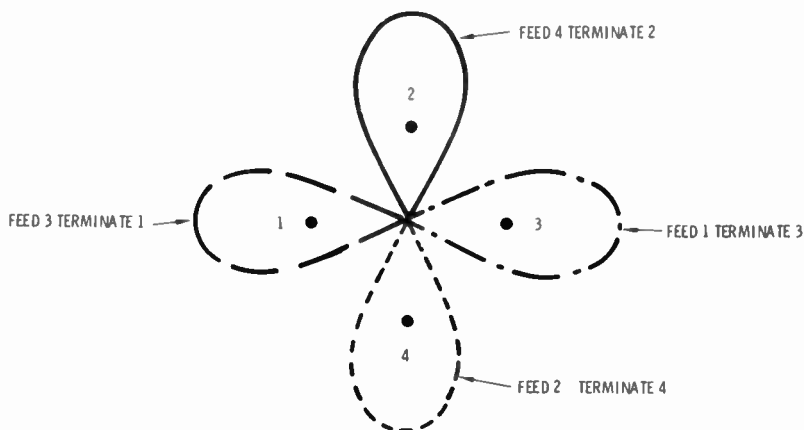

Fig. 96. Two-mast rhombic.

73 — Short Squared Rhombic

Do you have a plot of ground approximately 100-foot square for antenna erection? If so, an antenna mast mounted at each



(A) Unidirectional.

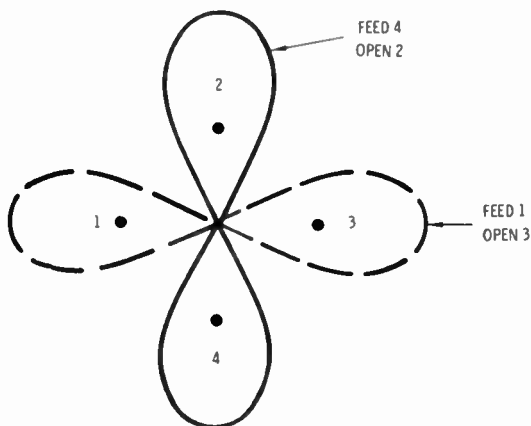

(B) Bidirectional.

Fig. 98. Different modes of operation.

four unidirectional patterns in the direction of the four poles and also two sets of bidirectional operation. These combinations are shown in Fig. 98.

The positioning of the masts in relation to the antenna erection area should be selected rather carefully in accordance with favored DXing directions. If you can get within 20° to 25° of a desired bearing, you can do reasonably well because the beam angle of the short rhombic is rather wide. Orientation is much less critical than for the very long rhombics.

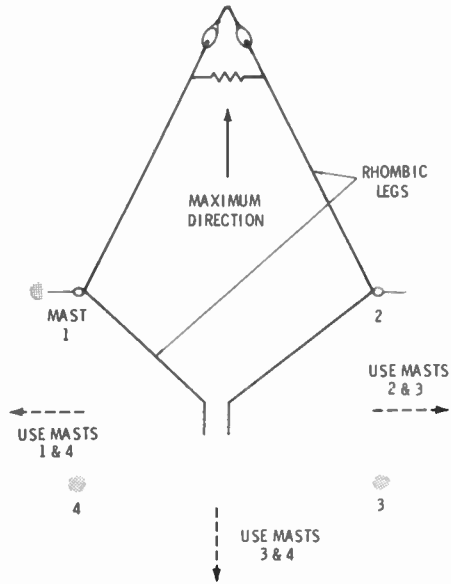

(A) Two-mast rhombic.

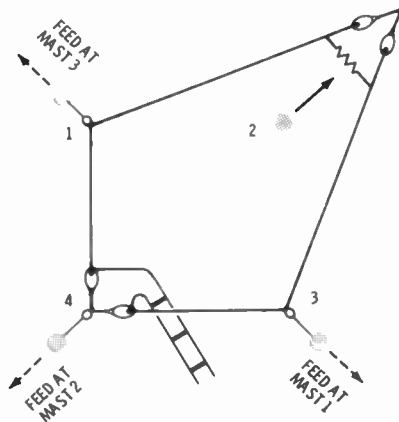

(B) Other directions available by changing feed point.

Fig. 99. Other antennas possible with four masts in a square.

When a reasonably omnidirectional pattern is desired, the antenna can be fed at one of the leg centers (Fig. 97). In this mode the wires at each of the four corners are jumped. For rhombic operation a jumper must always be placed across the insulator that is used for omnidirectional feeding.

The four-square mast installation is quite versatile and a variety of long-wire antennas can be constructed around this configuration. In this topic you learned how the four-square plan can be used for short switchable rhombic combinations. Previously in topic 71 it was used for switchable vee-beam antenna construction. Additionally, center-fed long wires can be placed in operation by using diagonal poles.

Longer two-mast rhombic antennas can be erected out of this basic plan, as shown in Fig. 99A. A choice of four possible directions can be made by coming out from the center of the hub. By establishing the feed point at one of the masts, four additional directions are made available as shown in Fig. 99 B. Refer to topics 1, 2, 57, 58, 59, 60, 61, 62, 63, 71, and 72.

APPENDIX I

Antenna Noise Bridge

The antenna noise bridge* is an especially useful device in cutting antennas to resonance and transmission lines to specific electrical lengths. It can also be used to measure antenna resistance. The unit consists of a signal source, the bridge circuit, and a detector (Fig. A-I-1). A diode noise generator and amplifier is built into the compact device along with the bridge. Your ham receiver serves as the detector. In fact, the noise generator is a broadband type and your ham receiver serves as a calibrated frequency-selective detector.

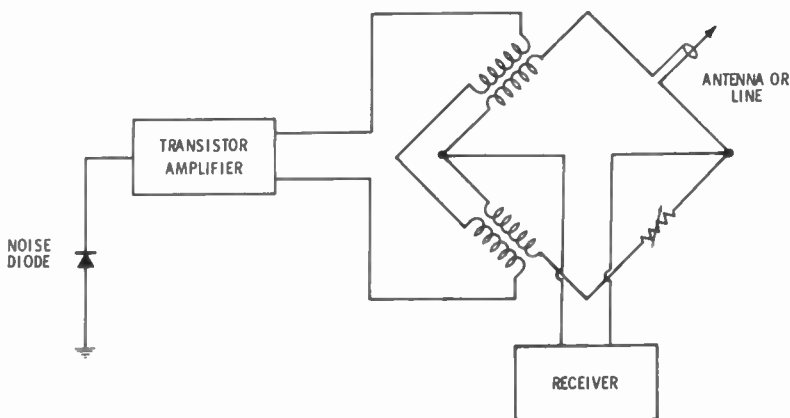

Fig. A-I-1. Omega-T antenna noise bridge.

Two balanced legs of the bridge are the secondary of a bifilar transformer which is wound on a toroid core. The broadband noise signal is applied across the primary. A third leg of the bridge is a calibrated variable resistor which is the only control of the unit. The dial is calibrated in ohms of antenna resistance between 0 and 100 ohms.

*Omega-T Inc., Richardson, Texas 75080

The antenna or line to be measured is connected as the fourth leg of the bridge. The receiver is, of course, connected between the junctions of the two leg pairs. When the bridge is balanced, there is minimum signal applied to the receiver. This happens when the antenna resistance is of the same value as the setting of the bridge resistor. If reactive components are present, the bridge does not balance. Any such reactance is balanced out by tuning the receiver. In doing this you also determine the resonant frequency of the antenna system.

The general operating procedure is:

1. Set the bridge control to the appropriate antenna resistance that is to be expected; for many ham antenna systems that is 50 ohms.
2. Tune the receiver over the frequency band to which the antenna is to be resonated. Find the minimum noise frequency (minimum audio output from the speaker and minimum S-meter reading).
3. Adjust the bridge resistance for the best minimum (null). Jockey the receiver tuning and bridge controls slightly for the best minimum. The resonant frequency of the antenna system is read from the receiver dial, while the antenna radiation resistance is indicated on the noise-bridge dial.

The antenna noise bridge is a small test unit, is easy to hook up, and makes antenna system checking a lot easier.

APPENDIX II

How to Measure the Velocity Factor of Transmission Line With a Noise Bridge

The noise bridge described in Appendix I can also be used to make transmission-line checks and measurements. Velocity factor is an important line characteristic in cutting lines to specific electrical wavelengths. Sometimes the information is not available from the manufacturer or it is necessary to know the velocity factor very exactly. If such is the case, the hookup of Fig. A-II-1 can do the job.

The near end of the transmission line is connected to the antenna terminal of the noise bridge. The far end of the line is shorted. At some frequency the total length of the line will be an



Fig. A-II-1. Determination of velocity factor of transmission line.

electrical half wavelength or a multiple of a half wavelength. At this frequency a short is reflected to the near end of the line, and there is no reactive component. The electrical length of the line is determined as follows:

1. Set the noise bridge dial just a hair away from zero corresponding to the few ohms of resistance of the transmission line. Tune the receiver for a noise null. It is customary to check a section of line that is approximately one-half wavelength long although multiples can be used for making the measurement.
2. Now measure the physical length of the transmission line. The velocity factor is obtained by dividing the physical length of the line by the calculated free-space half wavelength of the frequency indicated by the receiver dial.

$$\text{Velocity factor} = \frac{\text{physical length of line}}{492/\text{receiver freq. reading in MHz}}$$

The length of a quarter-wave segment of line or an odd multiple of a quarter wavelength can be determined in the same way with the exception that the far end of the line is opened rather than shorted.

APPENDIX III

Cutting Half-Wave Sections of Transmission Line Using the Antenna Noise Bridge

When the velocity factor of a transmission line is known, it is possible to cut that line to some whole multiple of a half-wavelength using the following relationships:

$$\text{Line length in feet} = VF \times \frac{492}{f\text{MHz}} \times \text{whole multiple of } \lambda/2$$

If the velocity factor of a specific line is unknown it can be determined using the procedure of Appendix II.

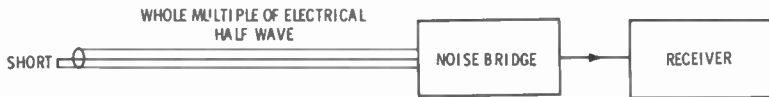

Fig. A-III-1. Method for cutting a transmission line to whole multiple of a half wavelength.

Once a section of line is cut, its exact electrical wavelength can be determined with the arrangement of Fig. A-III-1. Again the far end of the line is shorted while the near end is connected to the antenna terminal of the antenna bridge. This procedure is as follows:

1. Set the bridge control slightly above zero. Set the receiver to the desired frequency band.
2. Tune the receiver over the band to obtain a good null. For some receivers a more pronounced null can be obtained by deactivating the avc circuit and/or reducing the receiver r-f gain.
3. If the frequency indication is too low, the length of the transmission line can be trimmed slightly to make the electrical length of the line correspond to a specific operating frequency within the band.

The velocity factor of some foam-type lines tend to be less than 0.81. Thus resonance will appear at the low end of the band, or even off the low end of the band. Trim the line patiently to bring it into the band. When the overall length of your line is a *number* of whole multiples of a half wavelength long, a larger section of line must be trimmed off to obtain a given change in overall electrical length than if line were only *one* half wavelength long.

APPENDIX IV

Measuring the Resonant Frequency and Resistance of an Antenna With the Antenna Noise Bridge

The antenna noise bridge is battery operated and can often be placed at the antenna feed point, Fig. A-IV-1. It is of small size and no external signal source is needed. A noise generator source is a part of the device.

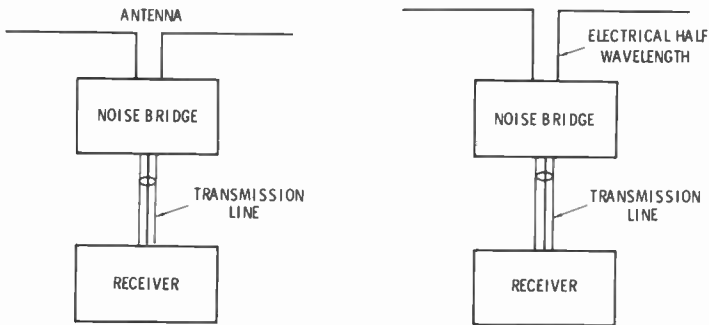

(A) Bridge at feed point of antenna. (B) Bridge at half wave from antenna terminals.

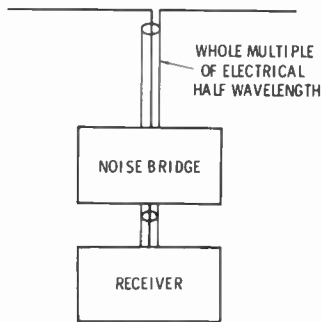

(C) Bridge at the receiver.

Fig. A-IV-1. Arrangements for measuring antenna resonance and antenna resistance.

The bridge can also be inserted into the line an exact electrical half wavelength away from the antenna terminals. A third alternative is to locate the noise bridge at the receiver, making certain that the overall length of the transmission line between the antenna and the bridge is a whole multiple of an electrical half wavelength for which the antenna is to be cut and measured. The transmission-line cutting procedures were covered in Appendices II and III.

The recommended operating procedure is as follows:

1. Set the noise bridge dial to the anticipated resistance of the antenna (usually 50 or 70 ohms).
2. Tune the receiver over the frequency band and locate the noise null (minimum speaker noise or minimum S-meter reading).
3. Adjust the antenna-noise-bridge dial for the best noise null.
4. The resonant frequency of the antenna can be read from the calibrated receiver dial while the antenna radiation resistance is indicated on the calibrated noise-bridge dial.
5. The two controls can be adjusted slightly for the very best null and the most accurate reading.

The most accurate readings are obtained when the transmission line is a whole multiple of an electrical half wavelength.

In the measurement and cutting of both lines and antennas, the Charts 1 through 6 are employed. The physical lengths of lines and antennas indicated by the charts are invariably somewhat longer than the necessary cut for the desired resonant frequency. (Even the cut for a half-wavelength antenna using the end correction factor is usually a bit longer than necessary.) This is the favorable situation because the antenna or line can then be trimmed back to the desired higher resonant frequency.

Therefore, in using the antenna noise bridge, the null point is usually found lower than the desired operating frequency and may sometimes be even lower than the low-frequency end of the desired frequency band. You can then trim very carefully and observe the noise null rising higher toward the desired frequency.

As you well know, cutting a length that falls on the high side of the desired frequency presents the added problem of having to add on rather than trim off to reach the optimum frequency. This is certainly not the desired situation when using coaxial transmission line. Thus the chart and formula information in this book tends to give you a long dimension rather than a short one.

This can be checked throughout the text by comparing the formula dimensions with those practical situation dimensions shown on the various antenna illustrations. If you have no means for checking and trimming antennas and lines use dimensions given in the illustrations and duplicate exactly the antenna arrangement shown.

APPENDIX V

Cutting an Antenna to Resonance Using an SWR Meter

The SWR meter and/or reflectometer arrangement have been used for years in checking out and monitoring ham antenna systems. Resonant antenna cuts can be made with the proper insertion of an SWR meter designed for the specific impedance of the transmission line. (For the usual SWR meter, optimum performance is obtained with 50- or 70-ohm coaxial lines.)

Two preferred arrangements are shown in Fig. A-V-1. True SWR measurements can be made by inserting the meter right at the antenna. Usually this is not a convenient arrangement. An alternative is to insert the meter one electrical half wavelength away from the antenna terminals or at some part of the line that is a whole multiple of an electrical half wavelength. The latter plan permits the SWR meter to be located near the transmitter. However, the very best accuracy in terms of the SWR reading and

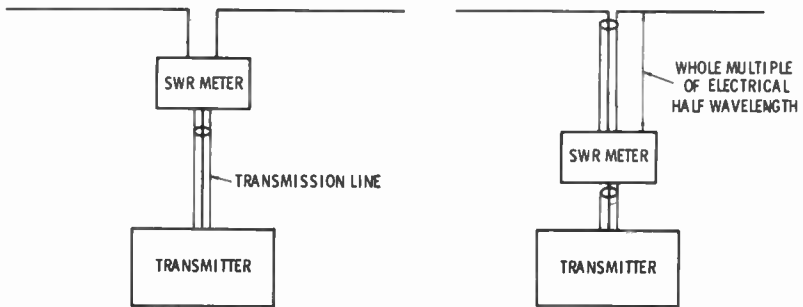

Fig. A-V-1. Measurement of SWR and antenna resonance.

in determining the resonant length of the antenna is feasible only when the exact length of line between the antenna and meter is a whole multiple of electrical half wavelengths. Under this condition the antenna terminal conditions are reflected to the meter and the reactive effects of the transmission line are reduced. The

equation for determining the physical length of an electrical wavelength line for a given frequency is as follows:

$$\text{Line length} = VF \times \frac{492}{\sqrt{\text{MHz}}} \times \text{whole multiple of } \lambda/2$$

The SWR measurement technique requires the use of a signal source (transmitter operated at low power level or a signal generator with an output capable of supplying adequate signal level to the SWR device). Because of transmitter designs, it is sometimes necessary to operate the transmitter at normal output power level, so that its operating conditions are favorable for matching into 50 ohms.

The usual procedure for operating your SWR meter is employed. In most cases when using the formula dimensions given in Charts 1 through 6 the antenna will be cut long and to a resonant frequency lower than that which is desired. Therefore if you tune your transmitter to the desired frequency and make an SWR measurement it will be higher than that which can be ultimately obtained. As you tune the transmitter lower in frequency the SWR reading drops. The actual minimum may be found considerably lower than desired.

The antenna may now be trimmed as you watch the SWR minimum move up toward the desired operating frequency. The resonant frequency indication and the SWR readings using this technique are reasonably accurate, and are more indicative of operating conditions than is indicated by random insertion of an SWR meter into a transmission line. In fact, with this method readings were quite comparable to those obtained using the antenna noise bridge for the many dipole and resonant long-wire antennas covered in this book.

APPENDIX VI

The Construction and Tuning of a Line Tuner

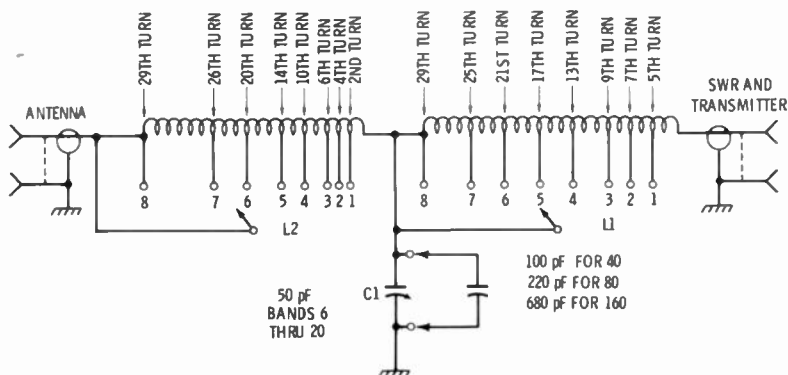

SETTINGS FOR ANTENNA OF TOPIC 31

59'		77 1/2'	
L ₂	L ₁	L ₂	L ₁
10	2	10	2
15	4	15	4
20	5	20	5
40	6	40	6
80	6-7	80	5-6

Fig. A-VI-1. Antenna line tuner.

- 2 binding posts
- 2 coaxial receptacles
- 1 case 10" X 5" X 4"
- 1 50-pF variable capacitor
- 1 100-pF mica capacitor
- 1 220-pF mica capacitor
- 1 680-pF mica capacitor
- 2 29 turns #14 wire, 1 3/4" dia. and 2 5/8" length (AIR DUX 1411)
- 2 r-f switches, 1 pole and 8 positions

The purpose of a line tuner is to provide the most favorable loading of a transmitter, although the impedance looking into the transmitter end of the transmission line is not optimum. Such a line tuner permits a given antenna to be used at a frequency removed from the limited frequency range for which it presents optimum loading conditions for the transmitter. It also permits the loading of a random length of antenna wire or permits a given antenna type to be operated on more than one amateur band. Such facility adds convenience and versatility to a station.

It must be emphasized that a line tuner does not improve the operation of an antenna and does not improve standing-wave conditions on the transmission line. It cannot duplicate the performance of an antenna made resonant at a specific frequency and matched precisely to the transmission-line system at that frequency. Even when using a tuner the very best antenna-system performance is obtained by establishing favorable resonant conditions at the antenna and using optimum lengths of transmission line that correspond reasonably close to whole multiples of a half-wavelength.

A line tuner does permit you to design an antenna system for peak performance over a certain desirable band of frequencies, and, with a tuner, you can at least operate your transmitter off of these frequencies and obtain results that are superior to those obtained without using a tuner. At the same time your transmitter operates under no burden because it sees a proper load impedance.

The tuner of Fig. A-VI-1 has been designed for optimum operation on the 10-, 15-, and 20-meter bands. It will also function on the 40- and 80-meter bands by connecting fixed capacitors of appropriate value across the variable capacitor (C_1).

The matching network is basically a T-section low-pass filter. Although there is some interaction between the two sections of the filter, inductor L_2 at the transmission-line (antenna) end of the tuner matches the antenna system impedance to the tuner, while the taps on inductor L_1 provide matching adjustment between the tuner and the transmitter and tune out reactive components reflected from the antenna system. Theoretically the ohmic value of the reactance of capacitor C_1 must be:

$$X_{C_1} = \sqrt{Z_{in} R_T}$$

where,

Z_{in} equals input impedance of line,

R_T equals the output impedance of transmitter.

In practice the proper operating conditions are established by using a variable capacitor and two tapped inductors in accordance with the parts list. It has been customary in most designs to place the taps on the coils in some regular manner and let the tuner operating conditions fall where they may. However, if the very lowest standing-wave ratios are to be established, it is helpful to experiment with tap positions for the very best performance. You may wish to start out with uniform positioning of the taps to determine what the operating conditions are on each band. For most bands it is likely that optimum performance can be obtained. However, if you have difficulty bringing the SWR reading down on certain bands, you can experiment with the tap positions. This is particularly the case for the 10- and 15-meter bands.

For the tuner constructed by the author the tap positions shown in Fig. A-VI-1 were found to be optimum. Switch positions for operation in the 10-, 15-, and 20-meter phone bands for the antennas of Fig. 40 are given. Coils L_1 and L_2 must be mounted at right angles to each other.

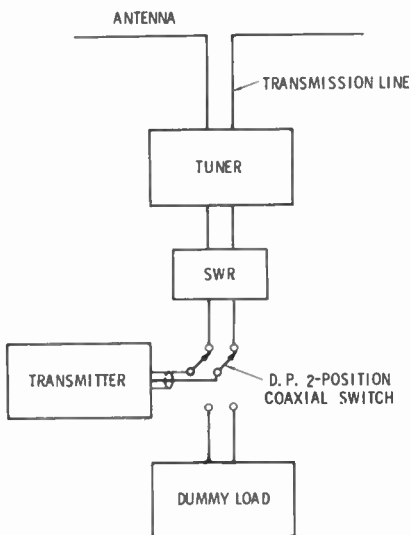

Fig. A-VI-2. Connection plan for adjusting a tuner.

Proper tuning is important if you are to derive the most benefit from your line tuner. The setup of Fig. A-VI-2 is a good one. The transmitter is first worked into a 50-ohm dummy load. Transmitter output-circuit settings (tuning and load) are set down in a notebook for specific frequencies. (You may wish to use the center frequencies of the 10-, 15-, and 20-meter phone bands.) This information helps you set the transmitter reasonably close to optimum and then the line tuner can be adjusted in such a manner

that the best performance is obtained with the transmitter preset. Some manufacturers provide tables for a match to specific impedances. If such is the case, preset the dials for 50-ohm operation.

Before turning on the power, preset the two tuner switches in accordance with the tuner information of Fig. A-VI-1. Operate the transmitter at low power and switch off the power whenever you change tuner switch positions.

Capacitor C_1 acts in a resonant way. If you are using the correct tap of inductor L_1 there is a dip in the SWR reading as you tune through the minimum position. The switch positions of inductor L_2 determine just how low an SWR reading can be obtained as the capacitor is tuned through its minimum. Thus various L_2 positions should be tried to determine the best minimum. If your minimum on any one band cannot be made to fall below 1.5, experiment with the appropriate tap positions of L_2 . Likewise if your minimum seems to be indicated at the minimum or maximum capacitor settings, a change in the L_1 inductor tap is indicated.

Using this technique the tuner of Fig. A-VI-1, when used with the antenna of Fig. 40, provided standing-wave ratios of less than 1.3 to 1 on any frequency in the 10-, 15-, and 20-meter bands.

One unusual condition arises when employing a line tuner of this type with a dipole, inverted-vee, or horizontal vee beam. A false matching position can show up for which the inner conductor of the transmission line and one side of the antenna acts as the

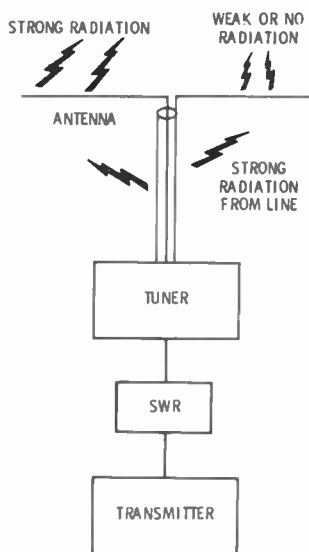

Fig. A-VI-3. Result of a tuner tuning the line and one antenna leg as random length of wire.

load (Fig. A-VI-3). In this case there is little or no r-f energy present at the far end of the second leg of the antenna. Thus, if at all possible, you should check for the presence of r-f energy at the ends of both legs of the antenna. This is quite easy to do for the inverted-vee antennas or the vee-beam types with sloping ends. False loading should be avoided when you wish no changes in the pattern characteristics of your antenna.

When the center-fed dipole or vee antenna approximates an odd number of quarter wavelengths on a leg, the tuner loads both legs. However, if the leg length approaches an even number of quarter wavelengths the tuner tends to load one leg and the line. For example, when the antenna of topic 31 with 59-foot legs is loaded on 80 meters, it will tune in dipole fashion on 80 meters. However the 40-meter dimension is so far off the quarter wavelength on a leg value that the tuner will simply load as a random wire with one leg more active than the other.

APPENDIX VII

Antenna Tuner for Long-Wire Vees and Rhombics

The purpose of an antenna tuner is to match and obtain the maximum transfer of r-f energy between the antenna end of a

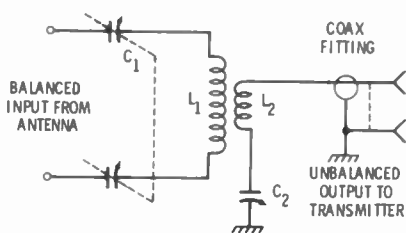

Fig. A-VII-1. Antenna tuner for vee, center-fed, long-wire, and rhombic antennas.

C_1 2 140-pF variables, ganged with insulated shaft connector

C_2 200-pF variable

L_1 - L_2 Plug-in coils (L_2 centered within L_1). L_1 AIR DUX 2006T except AIR DUX 2010T for 80 meters. L_2 AIR DUX 1610T.

Regular Coil Sizes.

Band	L ₁ Turns	L ₂ Turns
10-15	6	2
20	10	3
40	18	6
80	44	10

Intermediate Coil Sizes

Band	L ₁ Turns	L ₂ Turns
10-15	4	1
20-40	14	4
80	32 (2010T)	8

transmission line and the antenna. In the process, the SWR on the transmission line that links the tuner to the transmitter is brought down to a low value for suitable matching to the transmitter, and to ensure minimum transmission-line loss.

Resonant long-wire vees and rhombics usually have a low antenna resistance, and the step-up ratio between the transmission line and the antenna is not great. Hence, the rather simple tuner arrangement that matches a low-impedance unbalanced transmission line to a balanced antenna feed point of somewhat higher resistance is appropriate (Fig. A-VII-1). Both primary and secondary are series-tuned for minimum loss and lowest standing-wave ratio. Separate plug-in coils are recommended for each band. However the same plug-in coil can be used for both the 10- and 15-meter bands. Coil and component data are given in Fig. A-VII-1. Also given is coil data for intermediate values. If the very lowest SWR's for a variety of antennas are to be obtained, you may find one of these is better suited for a given situation.

The tuner adjusts very quickly and there is no need for making coil taps. An SWR meter is connected between the transmission line and the input of the tuner. Adjust the two tuner controls for a minimum SWR. Jockey back and forth between the two controls to obtain the very lowest minimum. The tuner must be re-adjusted, of course, when changing bands, or when changing from one end of the band to the other.

If you wish to construct a very versatile tuner that can meet almost any antenna situation around the amateur station, the author recommends highly the one described by Lew G. McCoy on page 58 of *QST*, July 1965. This tuner includes a standing-wave meter and has the flexibility needed to match both high and low antenna resistances.