

SEVENTY-FIVE CENTS

an **ALLIED** publication



integrated circuits

fundamentals & projects

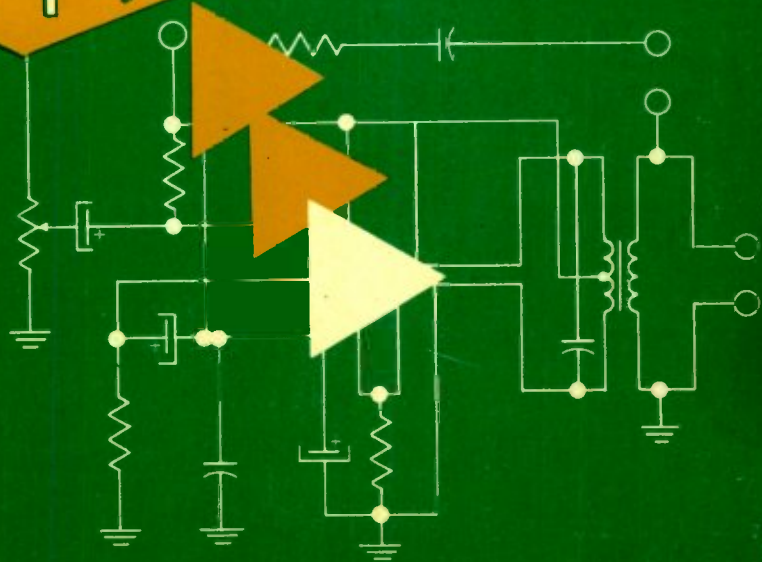
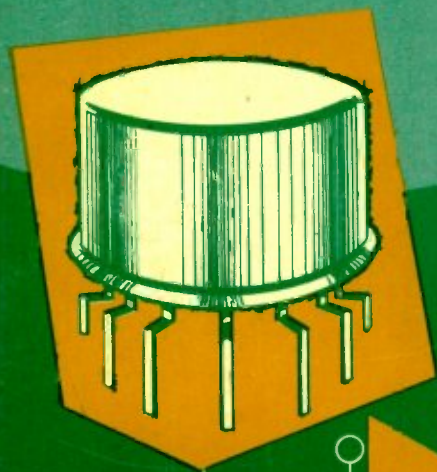

INTEGRATED CIRCUITS

Fundamentals & Projects

By

Rufus P. Turner, Ph.D.

Associate Professor Technical Writing,
California State College at Los Angeles;
Consulting Electronics Engineer; Senior
member, Society of Technical Writers
and Publishers; Member American Asso-
ciation for the Advancement of Science;
Author, *Semiconductor Devices*, *Transis-
tor Circuits*, *FET Circuits* and other
books on electronic subjects.

Published By

ALLIED RADIO CORPORATION

CHICAGO, ILL. 60680, U.S.A.

FIRST EDITION
FIRST PRINTING—AUGUST 1968
INTEGRATED CIRCUITS:
FUNDAMENTALS & PROJECTS

Copyright © 1968 by Allied Radio Corporation, Chicago, Ill. 60680. Printed in the United States of America.

All rights reserved. Reproduction or use, without express permission, of editorial or pictorial content, in any manner, is prohibited. No patent liability is assumed with respect to the use of the information contained herein.

Library of Congress Catalog Card Number: 68-9788

PREFACE

The purpose of this book is to help hobbyists and experimenters get acquainted with integrated circuits (abbreviated ICs). While a great deal of literature already has appeared, there is relatively little material in print for nonindustrial users. We hope to fill this gap, at least partially.

IC background material is presented in the first two chapters, and practical projects which may be built with simple tools and tested with common instruments are offered in the remaining ones. Each project uses only one IC. The devices described in the projects can be made much smaller than they are shown here—no attempt has been made to push miniaturization to its limit. On the other hand, our aim has been to keep each project small enough to exploit the small size of the IC, while at the same time keeping the device large enough that no special tools and skills are required to build them.

Several companies have helped us by supplying photographs and IC data. We thank the following: Motorola Semiconductor Products, Inc.; Radio Corporation of America (Electronic Components and Devices); Sylvania Electric Products, Inc.; and Texas Instruments, Inc.

RUFUS P. TURNER

CONTENTS

CHAPTER 1

MEET THE INTEGRATED CIRCUIT	7
Background—Nature of Integrated Circuits—Types of Integrated Circuits—How IC's are Used—Mechanical Specifications	

CHAPTER 2

PUTTING THE IC TO WORK	26
IC's in Circuit Diagrams—IC Installation—Use of IC's-General Method—Electrical Ratings of IC's—Construction Hints	

CHAPTER 3

SIMPLE AUDIO PREAMPLIFIER	40
Description—IC Employed—Construction—Testing—Uses	

CHAPTER 4

HIGH-GAIN PREAMPLIFIER	48
Description—IC Employed—Construction—Testing—Uses	

CHAPTER 5

QUARTER-WATT AUDIO AMPLIFIER	56
Description—IC Employed—Construction—Testing—Uses	

CHAPTER 6

FREQUENCY-STANDARD CRYSTAL OSCILLATOR	64
Description—IC Employed—Construction—Testing—Uses	

CHAPTER 7

AF/RF SIGNAL TRACER72
Description—IC Employed—Construction—Testing—Uses

CHAPTER 8

ELECTRONIC DC VOLTMETER83
IC Employed—Construction—Testing—Uses

INDEX94

CHAPTER 1

MEET THE INTEGRATED CIRCUIT

At this writing, the integrated circuit (abbreviated IC) has been commercially available only a short time; nevertheless, it has already begun positively to change the face of electronics. Fantastic miniaturization of stages and systems is being afforded by this device. Where formerly a “small” computer was at least the size of an office file case and had to stand on the floor, it now—through the use of IC’s—is about the size of a typewriter and can be set on the desk. Similar dramatic reduction of size is promised in industrial, military, consumer, and space products. The IC also has provided increased reliability, simplified construction of equipment, and greater ease of servicing.

This chapter introduces the IC, briefly tracing its development and describing its general features.

BACKGROUND

As the devices and systems with which we work become more complex, we have to think more and more in terms of groups and subdivisions; otherwise, we would have untold trouble understanding how the systems operate. Thus, we find ourselves thinking about how the *stages* of receivers, instruments, and computers work as units and in conjunction with each other (we think less and less about how each stage itself works). We carry this attitude further, when we can, by putting our systems together stage by stage and troubleshooting them in the same way.

Concept of the Module

With electronic circuits growing more complicated over the years, putting them together (either breadboarding or manufacturing) and troubleshooting and repairing them have be-

come harder and harder. One way to relieve the difficulty has been to build a whole stage (such as an IF amplifier, AF amplifier, detector, or counter) in such a way that it might be plugged into a large system (such as a receiver, amplifier, test instrument, or computer). In that way, systems can be put together relatively quickly by plugging prefabricated stages into a foundation unit (breadboard or frame chassis). Systems also can be serviced by quickly locating a malfunctioning stage, extracting it, and plugging in a good one. This type of thinking gave us the *module*.

A module is just such a plug-in or wire-in stage (some modules contain two or more stages). This device enables us to think of a stage in much the same way that we think of a block in the block diagram—principally in terms of what it accomplishes electronically and, secondarily, in terms of the components and circuitry inside it. It also enables us to assemble a system quickly from obtainable modules.

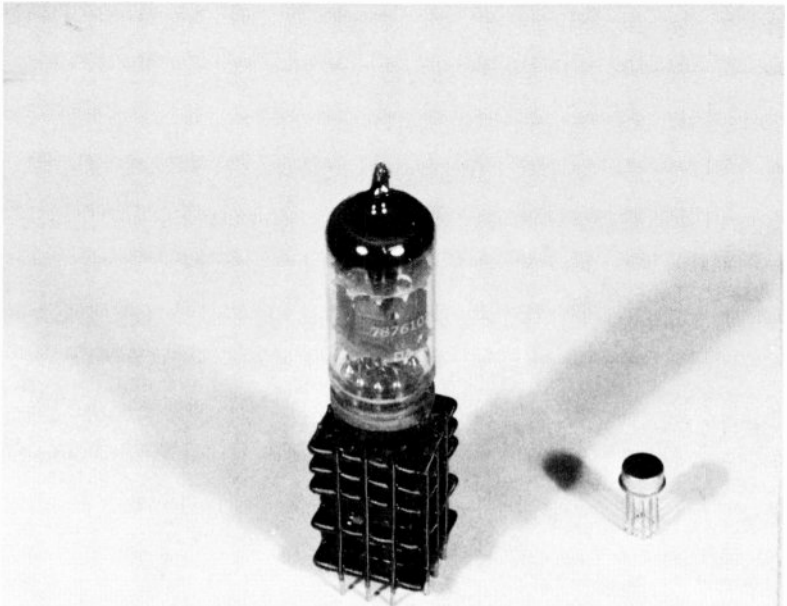

Fig. 1-1. Ten years of progress—a module and an integrated circuit.

Several kinds of modules have been available for over 10 years. These include box, can, and card types. Box and can types have been used often in receivers, transmitters, and test instruments; the card type has been especially prominent in digital computers, which may employ several hundred plug-in cards in a single machine.

All conventional modules employ discrete components; that is, they have definite resistors, capacitors, and coils. The first modules employed tubes and hand wiring; later ones used tubes and printed circuits. For example, the left unit in Fig. 1-1 is a tube-type, printed-circuit audio amplifier module employing "tinkertoy"-type construction. It uses a dual-triode tube, four resistors, and two capacitors. Still later modules employed transistors and hand wiring and, most recently, transistors and printed circuits.

In both the assembly and testing of equipment, all modules offered the advantages of simplicity, time-saving, compactness, and uniform wiring within a stage. And with the continued miniaturization of transistors, resistors, capacitors, and inductors, modules increasingly provided the additional advantage of small size. With the advent of printed-circuit resistors and capacitors, modules reached the ultimate in miniaturization for that type of device. But this size reduction was still short of what could be hoped for if the girth of large-scale electronic gear, such as computers, was to be cut down drastically.

Integrated Circuit as Super Module

The integrated circuit (IC) carries size reduction of the module into the realm of microminiaturization. Its dramatic achievement is easily shown: The unit at the right in Fig. 1-1 is an integrated circuit housed in a TO-5 transistor can (0.37-inch diameter, 0.18-inch height, 12 leads); but, in spite of its tininess, it contains 6 transistors, 2 diodes, 17 resistors, and all of the "wiring" between these components, which forms the internal circuit. Thus, in only 0.37 percent of the volume of the module on the left, the IC provides a circuit containing a great many more components.

It is because of their small size that IC's are also called *microcircuits*, and their design and application *microelectron-*

ics. These circuits sometimes are no larger than the head of a straight pin, sometimes smaller. When leads of actual wire are used in them—for connections between the IC and the outside terminals—these wires are almost invisible, being thinner than human hair. Because of the intimate relationship between components inside the IC, some slight electrical interaction may occur in some types. However, such interaction is usually negligible, and the user may proceed as if he were working with a module containing discrete components.

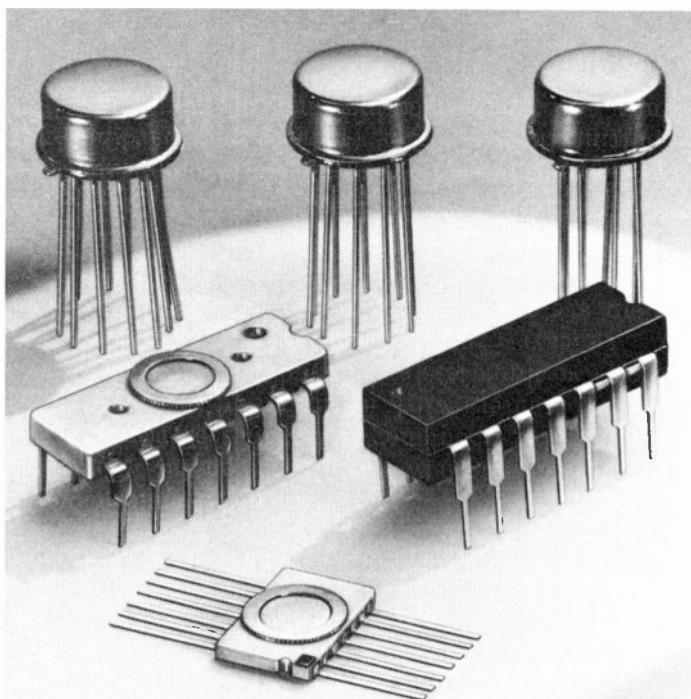

Courtesy Radio Corporation of America
Fig. 1-2. Typical integrated-circuit packages.

It is evident that many more stages or subsystems may be plugged into a system when using IC's than when using conventional modules. Fig. 1-2 shows the outside views of six typical IC's (most IC's, at this writing, are supplied in pack-

ages of these six types). In the back row are three IC's housed in the transistor-type metal can mentioned earlier (at rear left is a 12-lead IC, at rear center is a 10-lead one, and at rear right is an 8-lead one). At center left is a 14-lead dual in-line ceramic IC; at center right is a 14-lead dual in-line plastic one. In the front of the group is a 14-lead ceramic-to-metal flat package. Dimensions of these units are given in Figs. 1-10 to 1-15. Special miniature sockets or fixtures are available for inserting either of these IC's into a circuit; or the IC's may be soldered directly into a printed circuit or wired circuit.

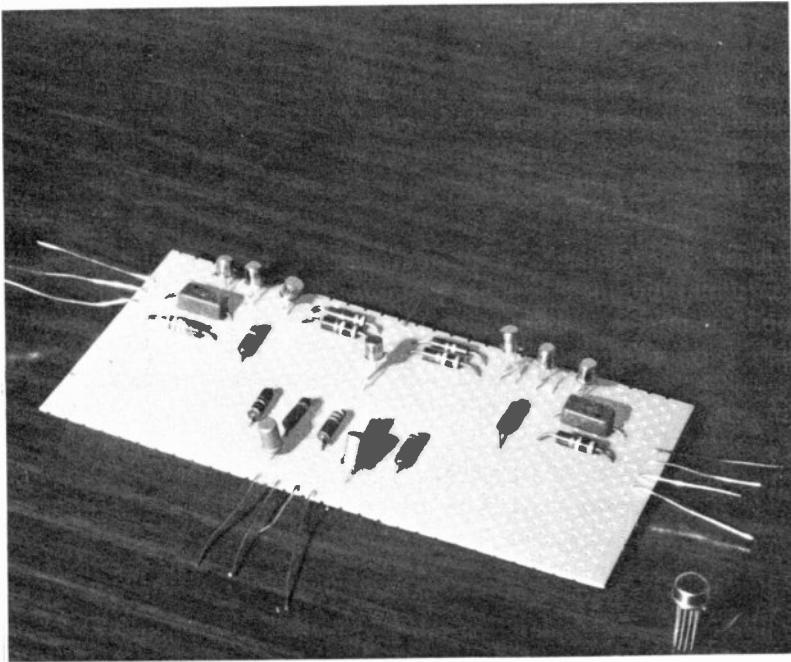

Fig. 1-3. Wired circuit shown with equivalent integrated circuit.

A further practical illustration of the size reduction afforded by an IC is given in Fig. 1-3. Here, a wired circuit card or board (left) is shown in contrast to an RCA CA3001 integrated circuit (lower right) that provides the same components and circuit (7 transistors, 2 diodes, 2 capacitors, 13 resistors, and 12 pigtailed). The wired circuit is assembled on

a 6-inch x 3-inch board, whereas the IC is housed in a 0.37-inch diameter, TO-5 transistor can. Fig. 1-4A shows the internal circuit of the IC, and Fig. 1-4B identifies the same components and leads in the wired circuit. The size advantage of the IC is obvious here.

Integrated circuits became available commercially in 1962. They now appear in some AM, FM, and television receivers; radars; missiles; satellites; hearing aids; hi-fi amplifiers; and test instruments; as well as citizens' band transceivers, electronic control gear, and computers. Because of the IC, equipment (or parts of it) have become smaller, cheaper, lighter, and cooler. When IC's are employed, the replacing of an entire circuit becomes as simple an operation as plugging in a transistor. Similarly, in the setting up of a breadboard, entire stages may be assembled without the labor of individually wiring each one.

NATURE OF INTEGRATED CIRCUITS

The IC is a solid-state product. Without the semiconductor manufacturing techniques developed by the transistor industry (and in particular the techniques of microminiaturization developed in 1958 by Jack Kilby of Texas Instruments, Inc.), this device would not be possible.

Whereas discrete transistors, diodes, resistors, capacitors, and wires are used in wired or printed modules, these components are fabricated into the body of a tiny semiconductor wafer (called a chip) in the IC. Through the use of transistor-making techniques, the chip is processed at the proper points to create a kind of "built-in" transistor, diode, resistor, or capacitor—and in other places to produce the low-resistance paths between these components, which simulate the connecting wires of the hand-wired circuit or the conducting areas of the printed circuit. Thus, all of the components and the interconnecting "leads" of a functional circuit are integrated within the chip, and this accounts for the name *integrated circuit*.

This brief chapter cannot possibly go deeply into the intricate process of IC manufacture. It is sufficient to explain here that the pattern of areas and lines that will constitute the

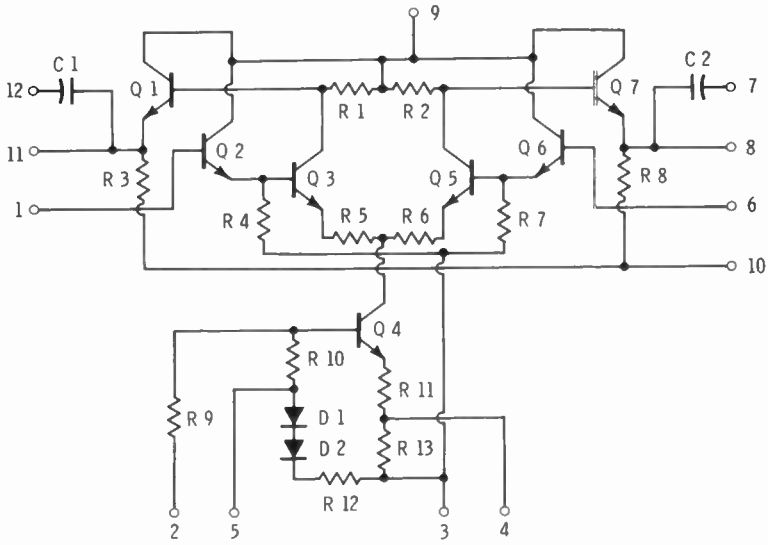

(A) Internal circuit of the CA 3001 integrated circuit.

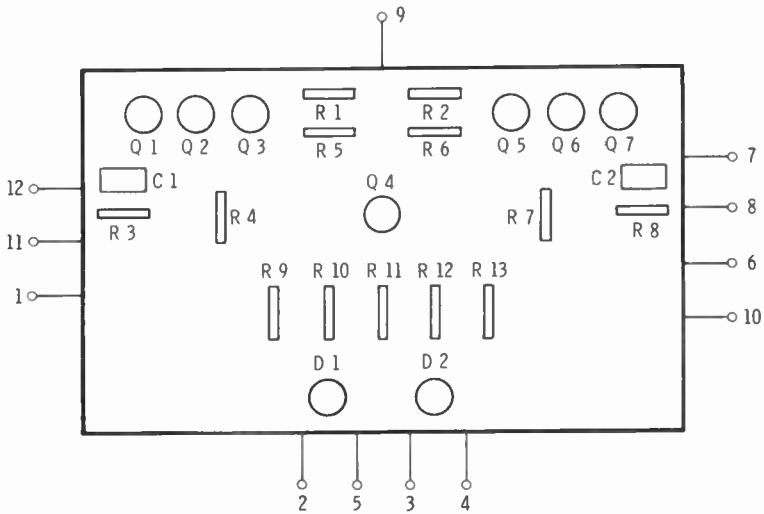

(B) Layout of the equivalent wired board.

Fig. 1-4. Integrated circuit versus wired board.

integrated circuit is first drawn large (this master pattern is often several hundred times larger than the resultant IC, as may be seen in Fig. 1-5). It is then reduced photographically on the light-sensitized surface of a silicon chip. In this way, the extreme miniaturization is obtained. After the pattern

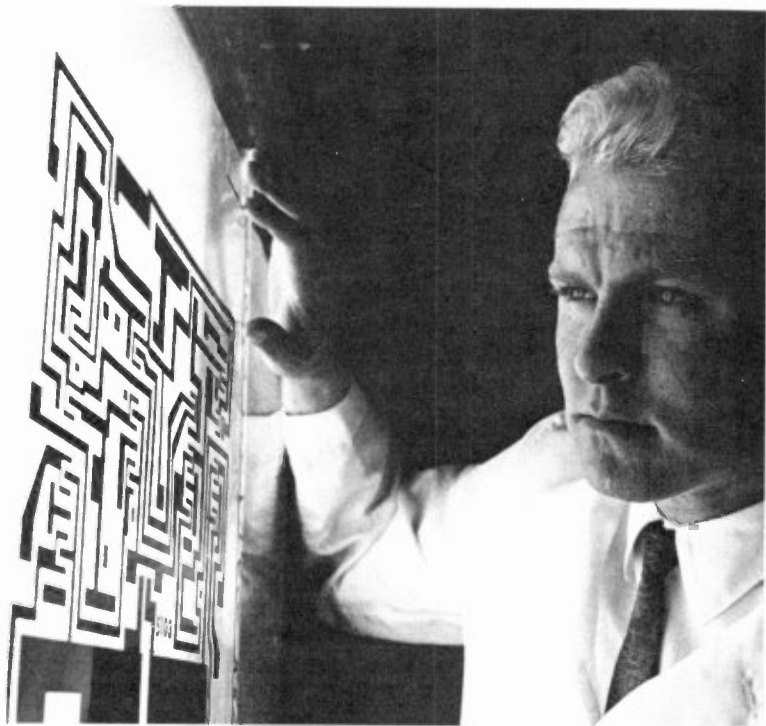

Courtesy Radio Corporation of America

Fig. 1-5. A preliminary step in the manufacture of an IC is the large size pattern which will be reduced photographically on the silicon chip.

thus has been “printed” on the chip, the latter is then processed chemically (acid-etched), electrically, or thermally (or in all three ways) to create the type and conductivity of the semiconductor in each part of the pattern to give resistor, capacitor, diode, or transistor action. (Sometimes, many chips are processed on a single large wafer from which they later are cut as separate, identical IC’s.) After completion of the process, fine leads are attached to appropriate points on the

chip, and the assembly is dried and then mounted in a suitable hermetically sealed container. (Fig. 1-2).

Under the microscope, the IC looks like a tiny printed circuit, but the lines and squares that are seen are not printed on the chip; they are processed into it, as explained in the

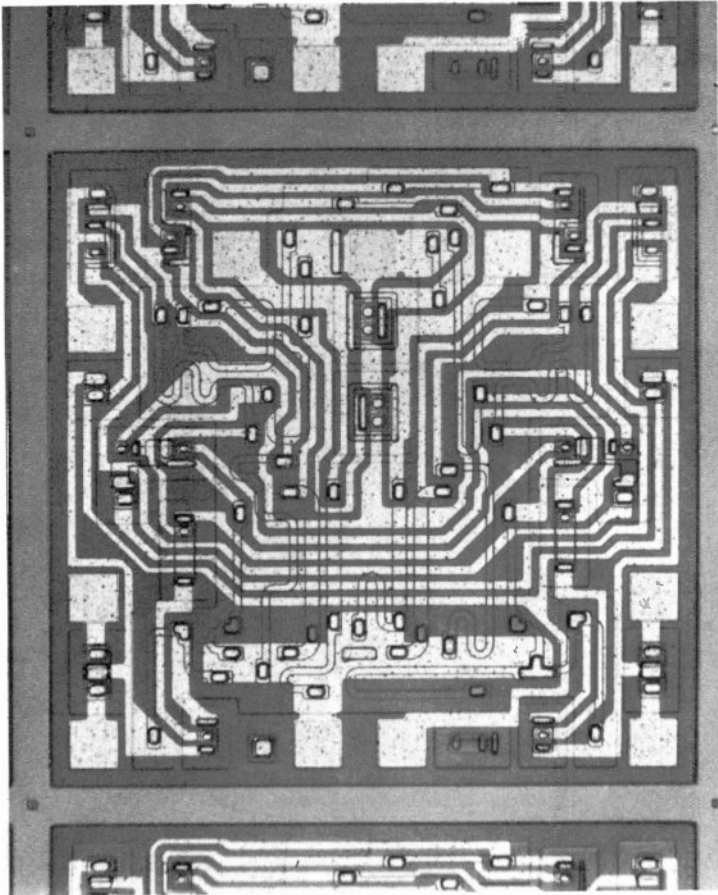

Courtesy Motorola Semiconductor Products, Inc.

Fig. 1-6. Enlarged view of an integrated-circuit chip.

preceding paragraph. Fig. 1-6 shows the top view of an IC chip, enlarged many times. Here, the light lines and areas are the circuit connections ("leads"); the large, dark areas

are transistors; and the slender, outlined paths are resistors. To give an idea of the small size of a completed IC chip, Fig. 1-7 shows seven of them placed on a Lincoln penny. (Approximately 150 of these chips could be placed on the coin.) Fig. 1-8 is an inside view of an in-line plastic IC package. The IC chip is in the center of the enclosure and thin leads connect the proper points on the chip to the external connector terminals.

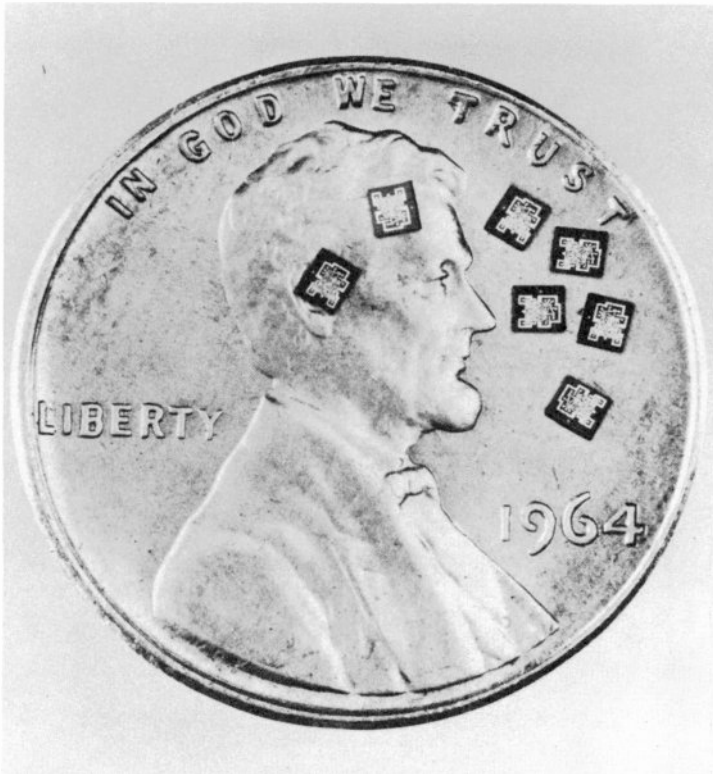

Courtesy Sylvania Electric Products, Inc.

Fig. 1-7. Seven complete IC chips on a penny.

In addition to the microminiaturization it affords, the IC provides stability and reliability of operation. Stability results from the integration of the circuit and all of its principal com-

ponents into a single chip of single-crystal silicon. Because the IC is a semiconductor device (that is, transistors and diodes rather than tubes), it usually generates little or no heat. Only those IC's that handle appreciable power (for example, those containing a power-amplifier stage) need a protective heat sink. Also, because the IC is a semiconductor device, its power requirements usually are modest (low voltage

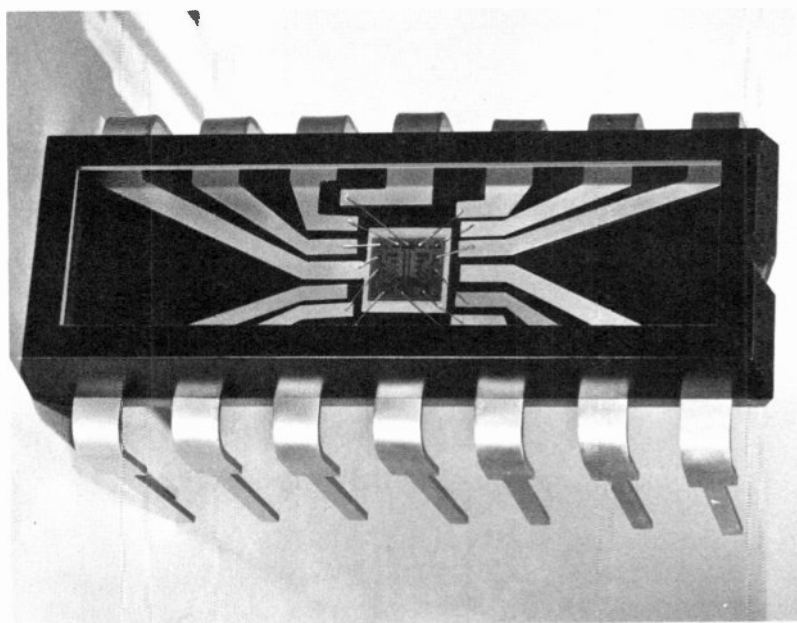

Courtesy Motorola Semiconductor Products, Inc.

Fig. 1-8. X-ray view of completed IC showing connection to terminals.

and/or low current). Temperature stability is promoted by making all components of an IC the closely spaced parts of a single-crystal silicon chip, so that they all tend to drift electrically by the same amount and in the same direction. But sometimes this is not enough, and in addition, some IC's employ a *current sink* to achieve even tighter control of drift. Thus, in Fig. 1-4A, a current sink is comprised by transistor Q4, diodes D1 and D2, and resistors R9, R10, R11, R12, and R13.

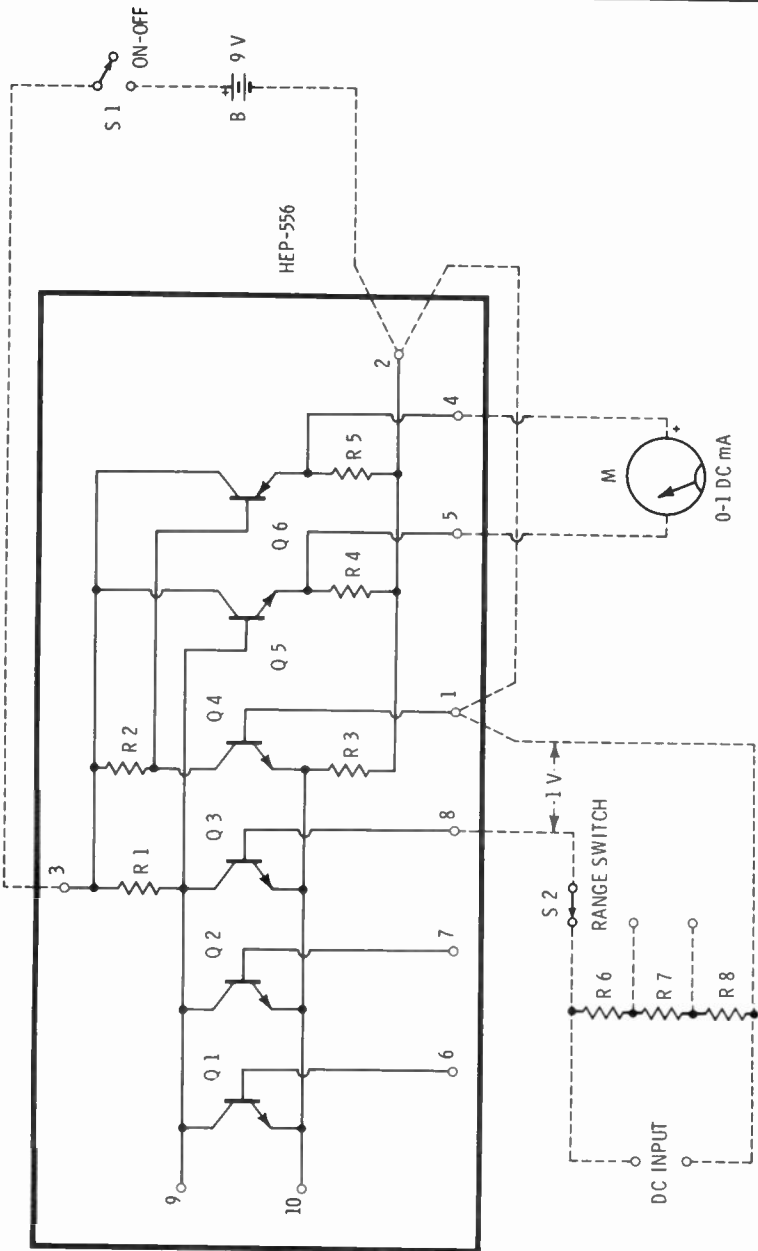

Fig. 1-9. Use of Motorola HEP-556 IC as electronic DC voltmeter.

TYPES OF INTEGRATED CIRCUITS

Depending on method of manufacture, IC's are considered to be of three types: *planar*, *thin-film*, and *hybrid*. Depending on internal circuit and intended class of application, they are considered to be of two types: *linear* and *digital* (sometimes called *nonlinear*). Thus, there can be IC's of the following kinds: planar linear, planar digital, thin-film linear, thin-film digital, hybrid linear, and hybrid digital.

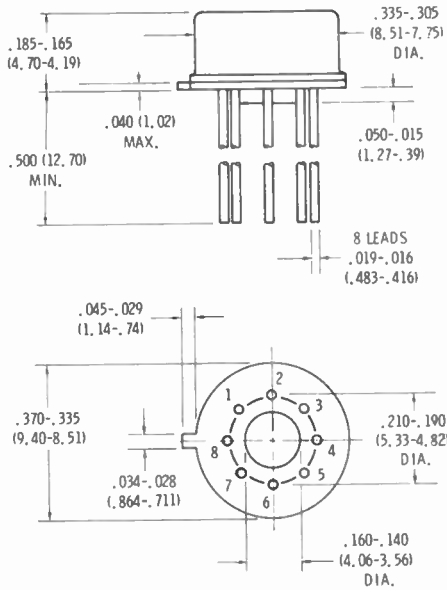

Fig. 1-10. TO-5 8-lead package.

Planar IC

The manufacturing technique for this type is similar to that employed for making planar transistors. It therefore offers the advantages common to planar transistors and diodes: high-frequency operation, high voltage breakdown, and passivation. Because all components and interconnections in the planar IC are formed in the solid silicon chip, this type is also termed *monolithic* (from the Greek expression meaning "single stone").

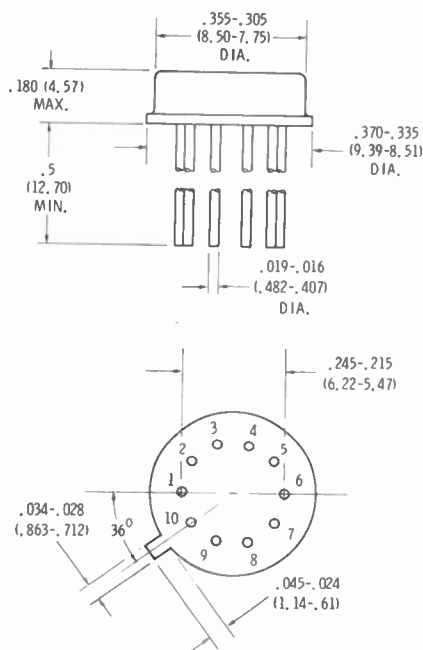

Fig. 1-11. TO-5 10-lead package.

Thin-Film IC

In this type, metallic and semiconductor substances for forming the IC components and interconnections are deposited in thin films on the semiconductor chip and then processed, electrically, chemically and/or thermally, for desired electrical properties. Presently, when the thin-film technique is used, it is to make IC capacitors, resistors, and diodes—not transistors.

Hybrid IC

This type is produced by a combination of planar (monolithic) and thin-film techniques.

Linear IC

The internal circuit of this type is designed to perform one or more of the linear (i.e., not on-off switching) electronic functions. Integrated circuits of this type include diode pairs

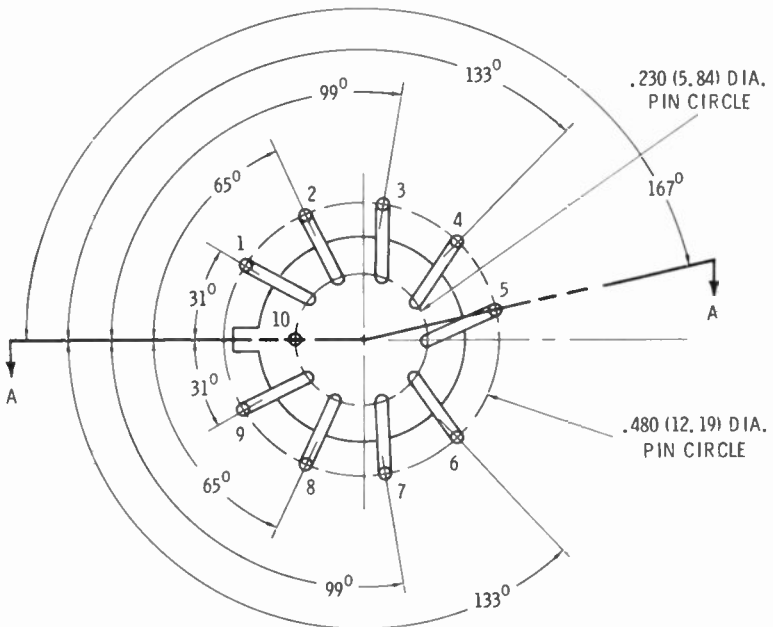
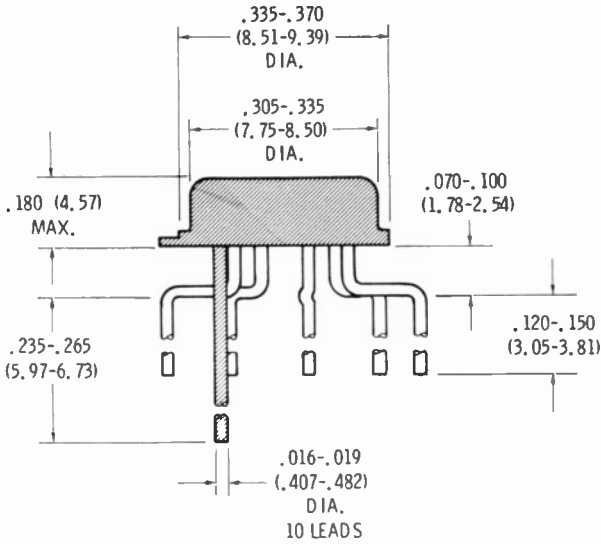

Fig. 1-12. TO-5 10 formed-lead package.

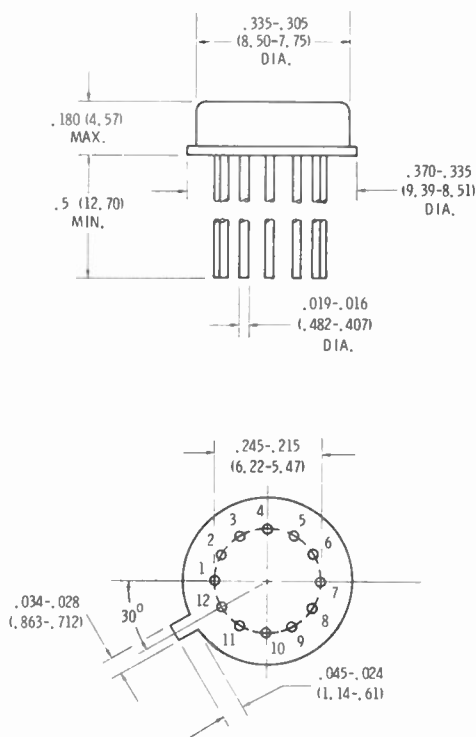

Fig. 1-13. TO-5 12-lead package.

and quads, transistor pairs and quads, Darlington circuits, DC amplifiers, AF amplifiers, RF amplifiers, IF amplifiers, operational amplifiers, video amplifiers, wideband amplifiers, phase detectors, FM discriminators, combination FM intermediate-frequency amplifier/discriminator/AF amplifiers, and voltage regulators.

Digital IC

The internal circuit of this type is designed to perform one or more of the nonlinear, switching or logic functions common to digital equipment. Integrated circuits of this type include buffers, gates (AND, OR, NOR, OR/NOR, and PHANTOM-OR), gate expanders, and flip-flops.

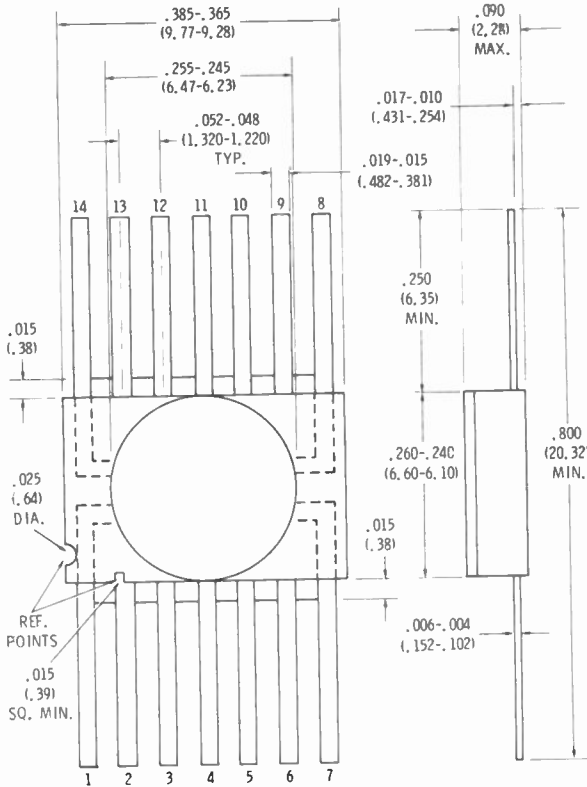

Fig. 1-14. 14-lead ceramic-to-metal flat package.

HOW IC's ARE USED

All or most of the required circuitry is inside the IC chip. The performance of the IC circuit may be modified as desired, however, by externally connecting a few components, such as resistors and/or capacitors, when needed. For example, resistance or resistance-capacitance feedback paths may be connected externally to tune an IC amplifier or to convert it into an oscillator. Thus, the RCA CA3020 integrated circuit, which is primarily a wideband amplifier (DC to 8 MHz), can be converted to a high-gain, $\frac{1}{2}$ -watt audio amplifier with speaker output by the addition of 2 resistors, 4 capacitors, an output transformer, and a volume-control potentiometer connected externally.

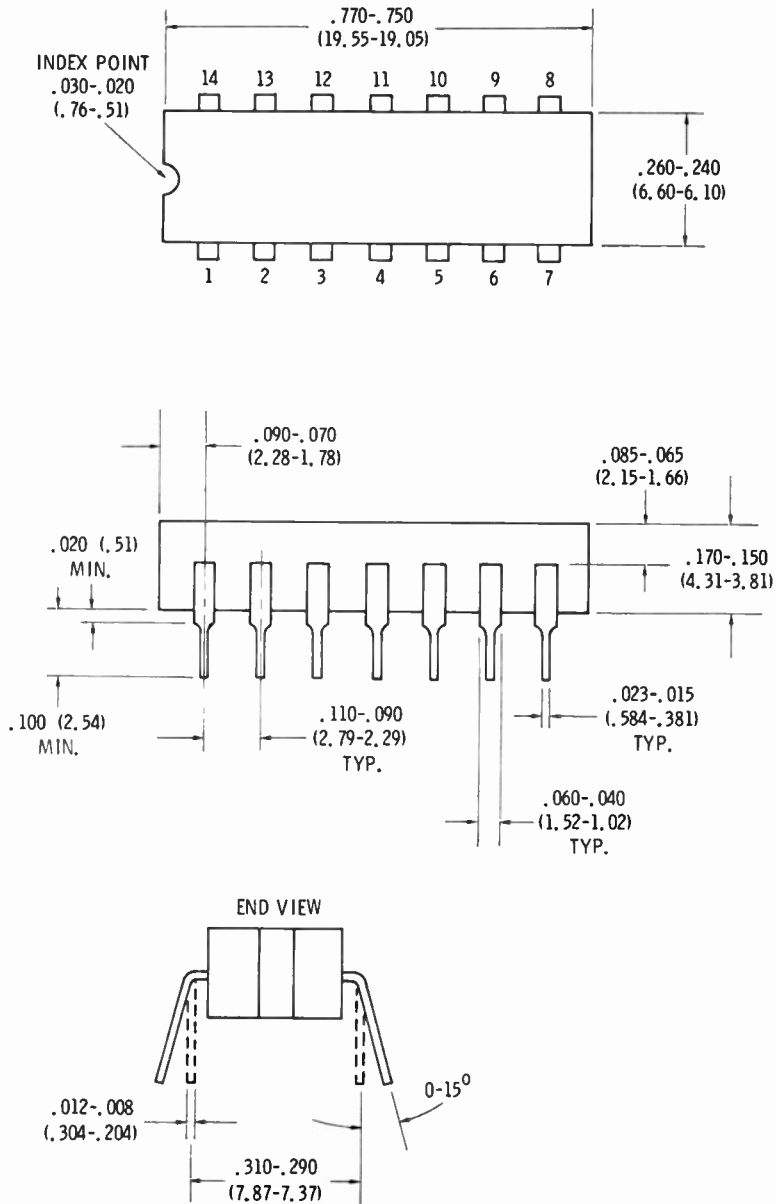

Fig. 1-15. 14-lead dual in-line package.

Each IC has been developed for a specific, primary application, either linear or digital. For example, its internal circuit may be that of an operational amplifier, three-input gate, flip-flop, or similar device. But, because points of the circuit are available through the IC terminals, the circuit (or portions of it) may be used at will for purposes other than the primary use. Thus, the Motorola HEP-556 integrated circuit is a three-input gate (a digital device); but, by means of external wiring and components (as shown by dotted lines in Fig. 1-9), it is easily converted into an electronic DC voltmeter (200,000 ohms per volt). The *outboard* components are ON-OFF switch (S1), a range-switching circuit (S2-R6-R7-R8), 9-volt battery (B), and 0-1 DC milliammeter (M). The unused components inside the IC (transistors Q1 and Q2) are simply ignored, and unused terminals 6, 7, 9, and 10 are left hanging. It is in this way that designers and experimenters are able to adapt existing IC's to a variety of applications.

MECHANICAL SPECIFICATIONS

Integrated circuits are supplied in several types of small packages (see, for example, Figs. 1-1, 1-2, 1-3, and 1-8). The shapes and dimensions of common packages are given in Figs. 1-10 to 1-15.

In Figs. 1-10 to 1-15, dimensions are given in inches (dimensions in millimeters are shown in parentheses). The terminal arrangements and numbering are shown in bottom views of the IC's, except that Figs. 1-14 and 1-15 are top views.

These outlines and dimensions will aid the designer and experimenter in choosing sockets and in planning layouts. They also will help the user to identify leads and terminals.

CHAPTER 2

PUTTING THE IC TO WORK

This chapter describes the fundamentals of integrated-circuit application. Pointers are given on care, installation, and use of IC's. This material should be read carefully before handling IC's, and especially before constructing any of the devices described in the next several chapters.

In ordinary handling, IC's seem to be as simple as transistors, but most of them are quite complex internally and present new problems of installation and of depiction in circuit schematics. Their complexity also demands that electrical ratings applied to them recognize that they are almost always complete circuits (amplifiers, switching devices, logic devices, etc.) containing both active and passive elements. They are not just single active components, like transistors and tubes. For these reasons, the newcomer to IC technology should become acquainted with the special installation and rating methods required for the IC.

No attempt has been made to give an exhaustive presentation of electrical characteristics. There is insufficient space here to cover the large number of IC's on the market and the large assortment of characteristics, some special. Instead, the reader's attention is called to the principal characteristics that are important to the newcomer, particularly in his handling and understanding of IC's in the practical projects presented later in the book.

IC'S IN CIRCUIT DIAGRAMS

There are several ways of representing an IC in a circuit schematic. These are shown in Fig. 2-1. Here, the IC is an RCA CA3002 unit (frequency range: DC to 15 MHz). This is a 10-lead unit in TO-5 can (see Chapter 1 for view and

dimensions). The IC is used with five outboard components; capacitor C1 and resistors R1 to R4.

Fig. 2-1A shows the complete internal circuit of this IC, together with the outboard components which complete the amplifier circuit. This method of presentation allows the viewer to see the full circuit of the IC and to determine which of the terminals and internal components are unused. The full presentation, as given in Fig. 2-1A, is seldom used, however, since it results in a very complex diagram, especially when several IC's are used.

In Fig. 2-1B, the conventional triangular symbol for an amplifier is used; none of the internal circuitry of the IC is shown. Use of the triangle is legitimate here, since the CA3002 is basically an IF amplifier. The terminal numbering on the triangle is the same as in the full circuit (Fig. 2-1A). In Fig. 2-1B, the numbering of the outboard components has been made to correspond to the numbers in Fig. 2-1A, although it places R1 and R2 in backward order in Fig. 2-1B. Greater simplicity results from use of the IC symbol shown in Fig. 2-1B.

In Fig. 2-1C, the symbol is actually the bottom view of the IC socket. Note that terminal 1 is adjacent to the key (or marker) on the socket, and that the terminal numbers increase clockwise around the socket. This is the simplest presentation of the three, and it is a very practical way of showing the IC and the external circuit when the diagram is to be used directly during wiring. It is this type of schematic that is used in the projects described in the following chapters.

IC INSTALLATION

The methods used to install an IC in a circuit are comparable to those for the installation of a transistor: (1) socket, (2) clips, (3) screw terminals, (4) soldering. Miniature round sockets (8-, 10-, and 12-contact types) are available for TO-5 type IC's, and miniature rectangular 14-contact sockets for flat packages and dual in-line plastic packages. Only TO-5 type IC's are used in the construction projects in this book.

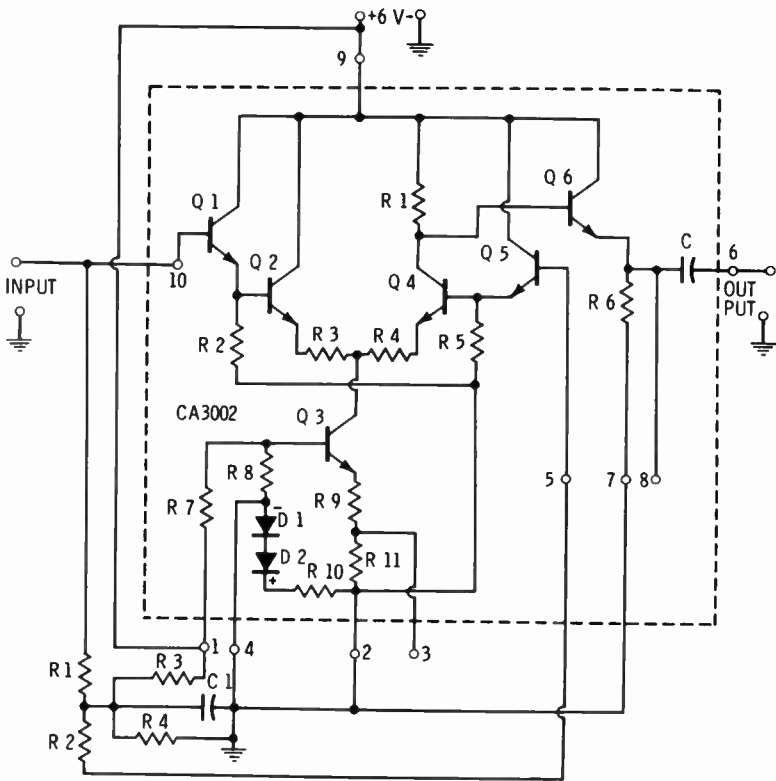

(A) Internal components of IC shown.

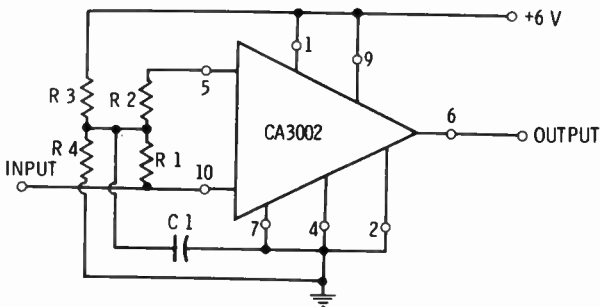

(B) Conventional triangular symbol for IC.

Fig. 2-1. Integrated circuit

An IC has up to four times as many terminal leads as a transistor and up to six times as many as a diode. This means very simply that six times as many mistakes can be made with IC's, and that six times as much care is needed in their installation. The leads of a TO-5 type IC are quite closely spaced and can easily be misaligned if the unit is clumsily handled.

Sockets

In most applications, a socket will be the most satisfactory holder. It allows an IC to be inserted or withdrawn quickly, and it does not hold the IC captive in one unit.

Two sockets for TO-5 type IC's are shown at left and center in Fig. 2-2. The left socket is a 10-contact, Cinch-Jones 10-ICS unit (Allied No. 47 J 0195). This socket is $\frac{3}{8}$ -inch in diameter, has narrow, flat leads, and has a ridge running vertically along its exterior adjacent to contact No. 1. This ridge acts as a key for mounting the socket. The center socket is a 12-contact Augat 8058 unit (Allied No. 47 J 6087). This socket is $\frac{3}{8}$ inch in diameter and has tubular leads. These two sockets are used in the projects described later in this book.

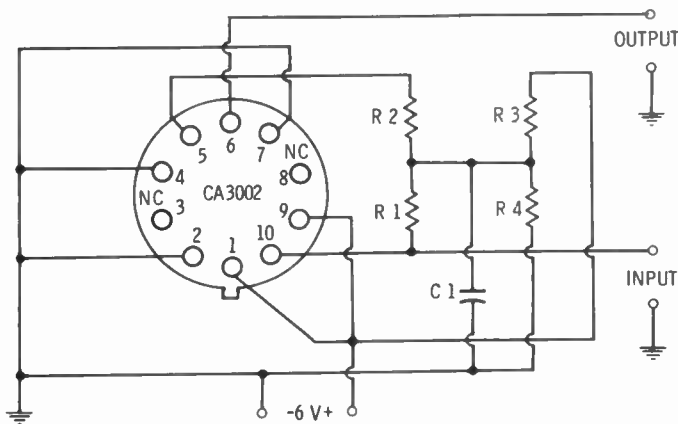

(C) Symbol is bottom view of IC socket.

in circuit diagrams.

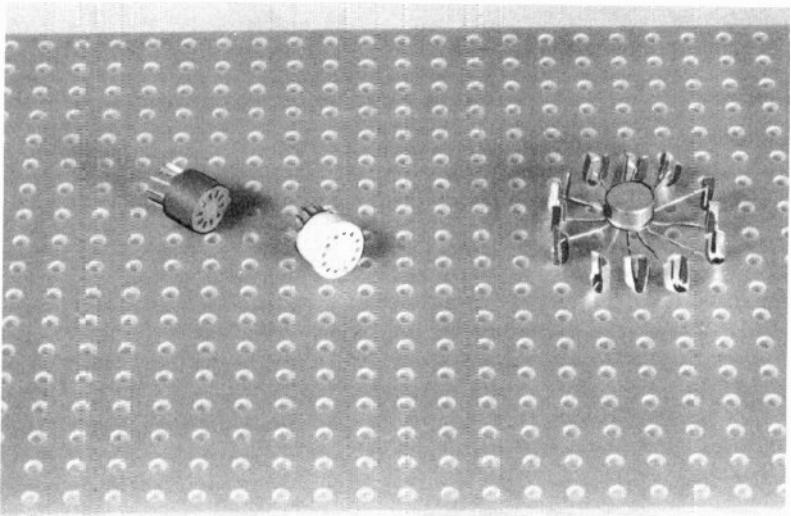

Fig. 2-2. Integrated-circuit sockets and mounting clips.

Because the socket terminals are so closely spaced, great care is needed in soldering leads or component pigtails to them. Use a fine-pointed soldering pencil in these close quarters, and take every precaution to prevent the flow of short-

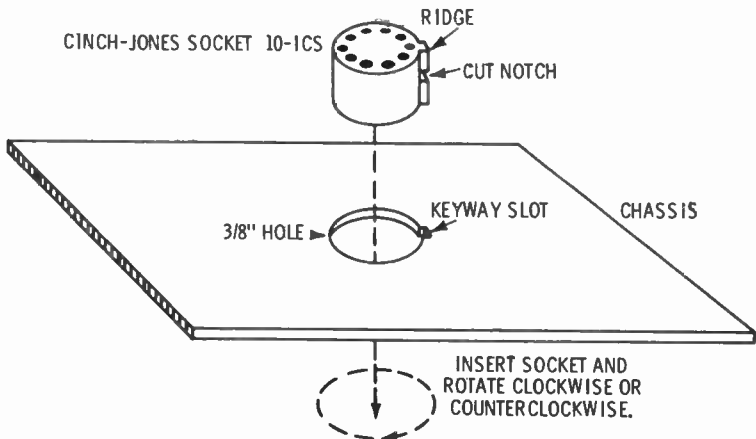

Fig. 2-3. Method of mounting IC socket.

circuiting solder between the socket terminals. The leads project straight down for a short distance from the bottom of the socket; and since they are so short, they do not need to be cut. In order to protect the close alignment of the contacts, leave the socket leads straight; do not bend them in any way.

These IC sockets may be cemented in place after they have been inserted into their holes in a plastic circuit board, or they may be fastened mechanically, as follows: The ridge of the Cinch-Jones 10-contact socket may be slotted, as shown in Fig. 2-3, with the width of the slot corresponding to the thickness of the circuit board or metal chassis on which the socket is to be mounted. After the socket is inserted into its hole, it may be turned to move the ridge away from the key slot in the hole. The split ridge then locks the socket to the board or chassis. The Augat 12-contact socket may be fastened in place with a $\frac{3}{8}$ -inch lock washer.

Complete all wiring to a socket before inserting an IC. Insertion requires more patience than is needed for transistors or tubes. There are 8 to 12 IC leads that must go into the socket holes, and they must be perfectly aligned with the holes. These leads are in good shape when the IC is taken out of its carton. Nevertheless, inspect them to be sure they are indeed straight and separated. It is best first to place each lead carefully just into its contact hole, after aligning the No. 1 lead of the IC with the No. 1 hole of the socket (use a toothpick or thin scratch awl to move the leads into the holes). Then press down on the top of the IC can firmly, so that all of the IC leads are pushed into their holes simultaneously, but gently enough that no lead becomes bent. Sometimes, the IC must be rocked back and forth a bit to urge the leads home.

Mounting Clips

On the right in Fig. 2-2, a 12-lead TO-5 type IC (RCA CA3020) is mounted by slipping its leads into Vector T9.4 push-in terminals (Allied No. 47 J 0878) arranged in a $1\frac{1}{4}$ -inch diameter circle on the perforated board on which the circuit will be wired. These terminals are easily pushed

snugly into the holes of the board and then rotated to receive the IC leads. The IC leads have previously been bent, like spokes, away from the can. The bend must be made carefully from a point $\frac{1}{8}$ -inch away from the bottom of the IC (bending right at the can may induce breakage).

The IC leads may be pushed readily between the jaws of the terminals if they are pressed gently. The jaws then grip them.

This method of mounting an IC is attractive to builders who want to avoid the cramped spacing of socket terminals. It is also a handy method when conventional sockets are not available, and is adaptable to any number of IC terminals.

Screw Terminals

Screws for gripping the leads of an IC may be arranged in a circle in the same way that push-in terminals are placed in the preceding example (5-40 screws, nuts, and solder lugs are a good size). The leads must be bent away from the IC can as before. Since each screw must be tightened after a lead is inserted under it, this method of mounting results in slower insertion and removal of an IC than other methods. Like the mounting-clip method, however, it provides more working space between terminals than a socket can, and it is convenient when a socket is not available.

Soldering

Integrated circuits may be soldered directly into circuits in which they are installed. Most commercial installations (and all printed-circuit applications) use soldering. This obviates the need for sockets or other hardware; however, it makes less convenient the transfer of an IC from one experimental circuit to another.

Soldering must be done very carefully to prevent heat damage to the IC. Hold the IC lead firmly with long-nose pliers between the IC and the point of soldering. Make a good solder joint as quickly as possible. Then continue to hold the lead with the pliers until it is completely cool. *Do not hurry.*

Unused IC Terminals

In some applications, not all of the IC components or terminals are used. Thus, in Fig. 2-1, the direct connection to the emitter of output transistor Q6 is not used, so neither is terminal 8. This is indicated in the following ways: In Fig. 2-1A terminal 8 is simply left with no connection, in Fig. 2-1B it is omitted from the IC symbol, and in Fig. 2-1C it is marked NC ("no connection"). In some diagrams of the type shown in Fig. 2-1B, *all* terminals of the IC are shown and each unused one is marked NC.

Unused terminals generally are ignored (they are left "hanging" when the circuit is being wired). In some instances, the IC manufacturer recommends that a certain unused terminal be grounded or connected to some circuit point, such as negative DC. But an unused socket terminal should not be used as a tie point, as often happens in tube-circuit wiring practice.

USE OF IC'S—GENERAL METHOD

There are two general methods of using integrated circuits, and all applications are some aspect of these two: (1) The IC is used directly, without externals except a DC supply and input and output signal terminals. This may be the specific use for which the IC was designed. Often, however, it is some other use that the unaided IC will serve equally well (thus, a video-amplifier IC may be used without modification as an audio preamplifier). (2) The IC is adapted to a desired application by modifying its performance with outboard components (thus, a wideband-amplifier IC may be converted into a sharply tuned bandpass filter by connecting an external feedback network—consisting of a few resistors and capacitors—between its input and output terminals; or a DC-amplifier IC may be converted into an emitter-coupled multivibrator by means of a single outboard capacitor). It is in these ways that the IC exhibits its versatility.

Most of the practical projects in this book adapt IC's to applications other than those for which the IC's were originally designed.

ELECTRICAL RATINGS OF IC'S

Because there are many types of linear and digital IC's, a long list of electrical characteristics is needed to describe their performance in every detail. The manufacturer's literature for a given IC lists each of the characteristics essential in rating that particular unit, and should be consulted by the circuit designer. The characteristics that are of chief interest to the IC beginner, however, are given below.

Supply Voltage

Supply voltage is expressed in volts (V) and is the voltage of the DC power source that supplies energy to the IC. There may be two supplies: V_{cc} and V_{ee} . The V_{cc} voltage is applied to the "collector end" of the IC and the V_{ee} voltage to the "emitter end." When there is a single supply, as in most of the practical projects in this book, it is V_{cc} . The V_{cc} voltage is positive with respect to ground, and is sometimes called the *positive supply* or *positive voltage*; the V_{ee} voltage is negative with respect to ground, and is sometimes called the *negative supply* or *negative voltage*.

Supply Current

Supply current is expressed in milliamperes (mA) and is the DC operating current drawn from the power supply by the IC. There are two such currents if there are two DC supplies: I_{cc} (collector current) from voltage source V_{cc} and I_{ee} (emitter current) from voltage source V_{ee} . Current I_{cc} is sometimes called *positive current* or *positive drain*; current I_{ee} is sometimes called *negative current* or *negative drain*. In some IC's, such as those employing a class-B output stage, maximum-signal current drain is higher than zero-signal current drain.

Power Dissipation

Power dissipation, expressed in milliwatts (mW), is the maximum DC power that may be dissipated safely by the IC. This sometimes includes AC signal power as well, and sometimes is a combination of DC operating power or control power.

Input Bias Current

Input bias current, expressed in microamperes (μA), is any current flowing into the IC signal-input terminals as a result of the application of a signal voltage.

Input Impedance

Input impedance, expressed in ohms (Ω) or kilohms ($\text{k}\Omega$) at a stated test frequency (kHz or MHz), is the AC impedance looking into the signal-output terminals of the IC.

Output Impedance

Output impedance, expressed in ohms (Ω) or kilohms ($\text{k}\Omega$) at a stated test frequency (kHz or MHz), is the AC impedance looking into the signal-output terminals of the IC.

Device Gain

Device gain, expressed in decibels (dB for a voltage ratio), is the open-loop voltage gain (unless otherwise specified). It is the ratio of output-signal voltage to input-signal voltage. Gain (A) may be expressed in several ways, corresponding to the type of amplifier IC as follows:

Single-Ended Voltage Gain—In an amplifier having single-ended input and single-ended output (Fig. 2-4A), $A_v = V_o/V_i$. In a differential amplifier having two inputs and one common output (Fig. 2-4B), single-ended voltage gain is the ratio of output voltage to one input voltage (i.e., $A_v = V_o/V_{i2}$). In a differential amplifier having two inputs and two outputs (Fig. 2-4C), single-ended voltage gain is the ratio of the signal voltage at the used output terminal to the signal voltage at the used input terminal $A_v = V_{o2}/V_{i2}$.

Common-Mode Voltage Gain—In a differential amplifier in which signal voltage V_{ic} (common-mode input voltage) is applied simultaneously to both inputs (Fig. 2-4D), the common-mode voltage gain is the ratio of the signal voltage measured between the two outputs to the common-mode input voltage ($A_c = V_o/V_{ic}$).

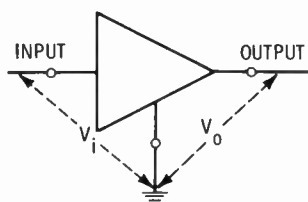

(A) Single-ended amplifier.

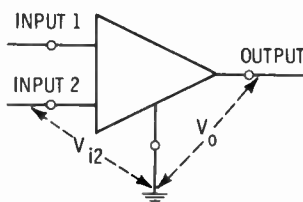

(B) Differential amplifier—single output, one side used.

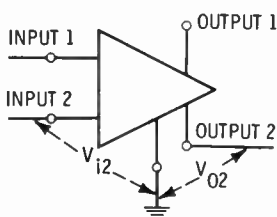

(C) Differential amplifier—dual output, one side used.

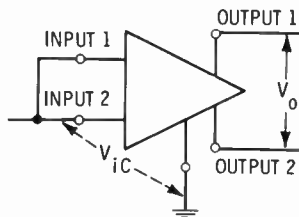

(D) Differential amplifier—common-mode input.

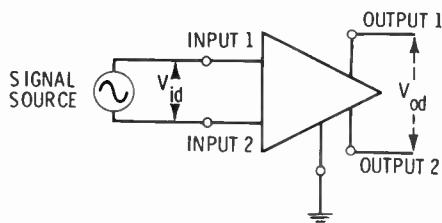

(E) Differential amplifier—both sides used.

Fig. 2-4. Various aspects of IC-amplifier gain.

Differential Voltage Gain—In a differential amplifier in which the input signal (differential voltage V_{ic}) is applied between the two inputs, and the output signal (differential voltage V_{od}) is taken between the two outputs (Fig. 2-4E), the differential voltage gain is the ratio of differential output to differential input ($A_d = V_{od}/V_{id}$).

Useful Frequency Range

Useful frequency range is expressed in megahertz as a bandwidth figure, or stated as beginning at a certain frequency

in kHz and ending at a certain frequency in Mhz. It is the frequency range over which IC performance is maintained within some specified response limits (for example, within a specified number of dB).

Harmonic Distortion

Harmonic distortion is expressed in percent (%), and is the ratio of the total harmonic voltage to the fundamental-frequency voltage in the output signal of the IC. It is specified at a stated test frequency or for a band of frequencies.

Maximum Input Voltage

Maximum input voltage, expressed in DC volts (V) or peak AC volts (V) for a given resistive load, is the maximum value of the input-signal voltage before distortion appears in the output-signal voltage.

Maximum Output Voltage

Maximum output voltage is expressed in DC volts (V) or peak AC volts (V). It is the maximum undistorted output-signal voltage that results from application of the maximum input voltage (see preceding item).

Noise Figure

Noise figure, expressed in decibels (dB), is the amplitude of electrical noise power generated by the IC. Sometimes (specified for a given test frequency), it is the ratio of the total IC output noise to the noise generated in the test-signal source.

Maximum Operating Temperature

Maximum operating temperature is expressed in degrees Celsius ($^{\circ}\text{C}$), and is the maximum temperature at which the IC may be continuously operated safely.

Operating Temperature Range

Operating temperature range, expressed in degrees Celsius ($^{\circ}\text{C}$), is the low- and high-temperature limits between which

the IC may be operated safely (for example, -55°C to $+125^{\circ}\text{C}$).

CONSTRUCTION HINTS

For success in the construction and operation of project devices described in the next chapters, observe the following rules. These apply to all projects; additional, specific instructions are also given with individual projects.

1. Use the exact components specified, except where substitution of an equivalent component is sanctioned in the instructions.
2. Follow the layout shown in the pictorial diagram.
3. Carefully follow the wiring diagram. Bottom views of IC sockets are shown.
4. Follow, step by step, the instructions for building and testing the projects.
5. For all soldering, use a fine-pointed soldering pencil and thin, rosin-core solder. Avoid acid-core solder and corrosive fluxes. Make a good tight mechanical connection before soldering it; then, complete the soldering quickly and with a minimum of solder.
6. For soldering to IC sockets, use the finest point of the soldering pencil, and be careful that no short-circuiting solder runs down between the socket leads.
7. Keep all circuit leads as short as is practical.
8. Do not employ any unused terminal of the IC socket as a tie point.
9. Complete and check all wiring before inserting the IC.
10. Carefully straighten and separate all IC leads before inserting into a socket. Start each lead into its proper socket hole; then press the IC gently to force it tightly into the socket. All leads must go in, all the way, at the same time.
11. Do not trim the IC leads unless you use very sharp cutters which will not bend or flatten the ends of the leads, and unless you can keep each lead straight.
12. Sockets are recommended for the beginner and experimenter; but when it is preferred to wire an IC directly into a circuit, install it in such a way that there is no

strain on the IC leads. When soldering IC leads, use a fine-pointed soldering pencil. Grip the lead with long-nose pliers between the IC case and the point of soldering, *and continue to grip it until cooling is complete.*

13. If IC leads must be bent for insertion into a circuit, make the bend no closer than $\frac{1}{8}$ inch from the IC case.
14. Do not exceed the specified power-supply voltage, unless the IC manufacturer's literature shows that a higher value may be used safely.
15. Check the polarity of the battery or other DC power supply.
16. When setting up the IC device, connect the power supply last.
17. Switch off the power supply before inserting or removing an IC.
18. When testing circuit voltages, use a vacuum-tube voltmeter or field-effect transistor voltmeter. If these electronic instruments are not available, use a 100,000 ohms-per-volt meter; and if that instrument is not available, a 20,000 ohms-per-volt meter.
19. Keep IC's clear of hot spots in other equipment.
20. Use a heat sink with any IC whose internal power dissipation causes it to become warm to the touch.

CHAPTER 3

SIMPLE AUDIO PREAMPLIFIER

This chapter gives construction details of a simple, general-purpose audio-frequency preamplifier which in a short time may be assembled, checked out, and put into operation. Employing a single IC and a 9-V transistor battery, this preamplifier has medium-impedance input, low-impedance output, very good frequency response in the AF range (20 Hz to 20 kHz), and low current drain. It is small enough to be easily

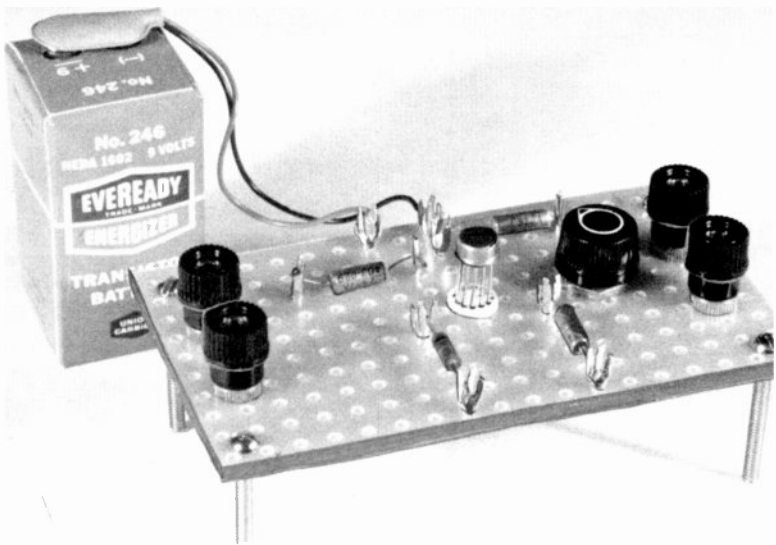
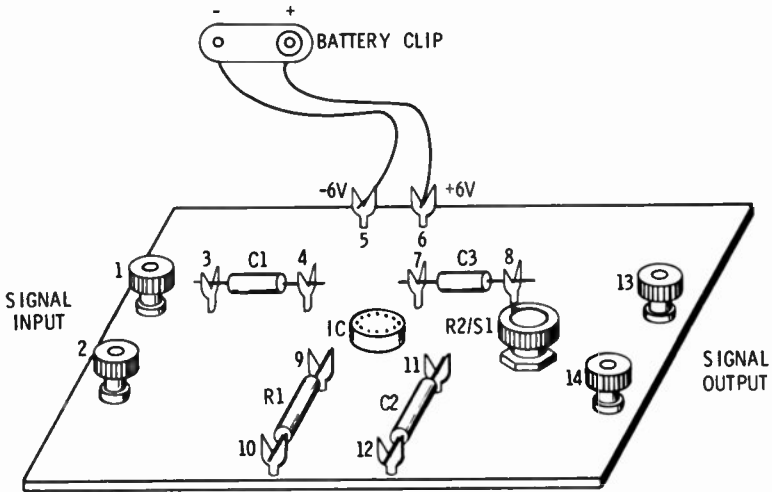
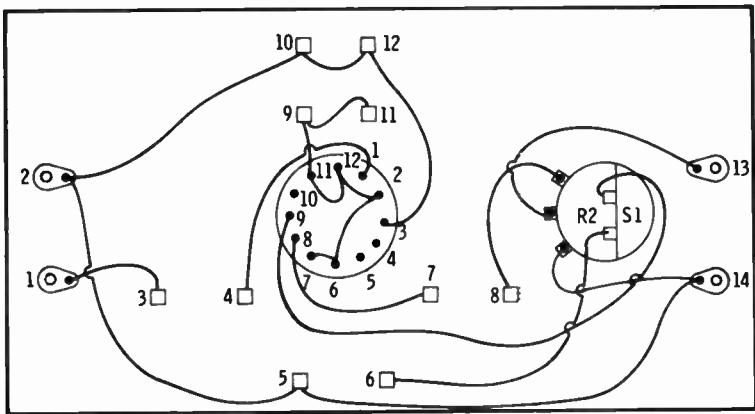

Fig. 3-1. Overall view of the completed preamplifier.



(A) Above-board layout.



(B) Below-board wiring.

Fig. 3-2. Layout and wiring of a simple preamplifier.

installed in other equipment, and accordingly will be found useful in receivers, instruments, transmitters, control devices, and larger amplifiers.

The circuit is uncompensated (instead, it operates "open", giving reasonably flat response throughout the useful audio spectrum). However, its response may be altered as desired, by the simple connection of appropriate outboard resistors and capacitors. The circuit uses no transformers.

DESCRIPTION

Fig. 3-1 is a view of the completed preamplifier with the IC plugged-in and the battery connected. Figs. 3-2 A and 3-2 B show the layout of components, and wiring; and Fig. 3-3 is the circuit diagram. For convenience in understanding the preamplifier circuit, Fig. 3-4 gives the internal circuit of the RCA CA3007 integrated circuit used in this project.

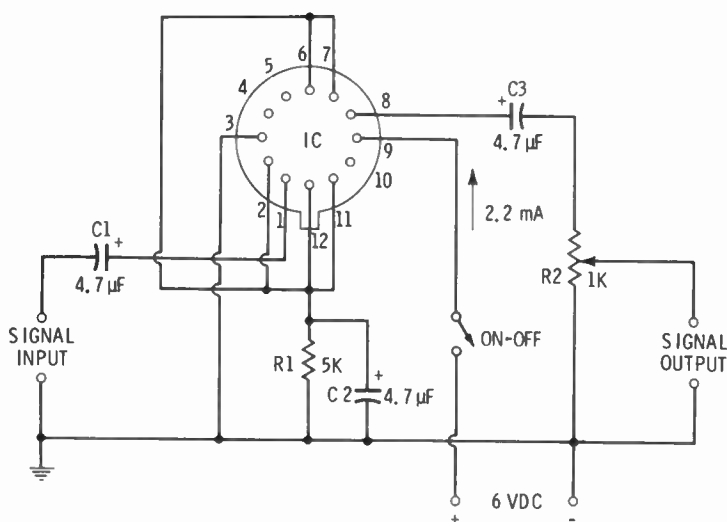

Fig. 3-3. Circuit of the simple audio preamplifier.

This preamplifier (Fig. 3-3) employs an RCA CA3007 IC and only five outboard components: capacitors C1, C2, and C3; resistor R1; and potentiometer R2. Response of the circuit is flat within 2 dB from 20 Hz to 20 kHz. When potentiometer R2 is set for maximum gain, the maximum signal-input voltage before output distortion begins is 0.04 volt rms, and the corresponding maximum signal-output voltage is 0.4 volt rms (this corresponds to an open-circuit voltage gain of 10). With a single 9-volt DC supply, the current drain is 22 mA under both zero-signal and maximum-signal conditions. Use of a transistor-type battery therefore is entirely feasible. The low-impedance output favors feeding the output signal into a low impedance line, which practically eliminates hum pickup. Placement of the gain control at the output, rather than the input, reduces the probability of potentiometer noise appearing in the output.

IC EMPLOYED

The RCA CA3007 integrated circuit, which is the heart of the preamplifier, is housed in a 12-terminal TO-5 can (see Fig. 1-13, Chapter 1, for outline and dimensions), and is rated at 4000 ohms input impedance and 60 ohms output impedance. Its useful frequency range is given as DC to 20 kHz, and its total harmonic distortion as 0.28 percent at 1 kHz.

Fig. 3-4 shows the internal circuit of the CA3007. Note that this IC contains two identical direct-coupled amplifier stages (Q1 feeding Q4, and Q2 feeding Q5). Each output stage has emitter-follower output. Transistor Q3, diodes D1 and D2, and the associated resistors form the stabilizing current sink. Transistor Q6 and resistors R11, R12, R13, and R17 stabilize the quiescent operating voltage at the output terminals (8 and 10) against variations of temperature and supply voltage. An input signal may be applied to input transistor Q1 through terminal 1, while the input terminal (No. 7) of input transistor Q2 is AC-grounded. As a result, Q1 and Q2 drive Q4 and Q5 in push pull and constitute an amplifier-type input phase splitter.

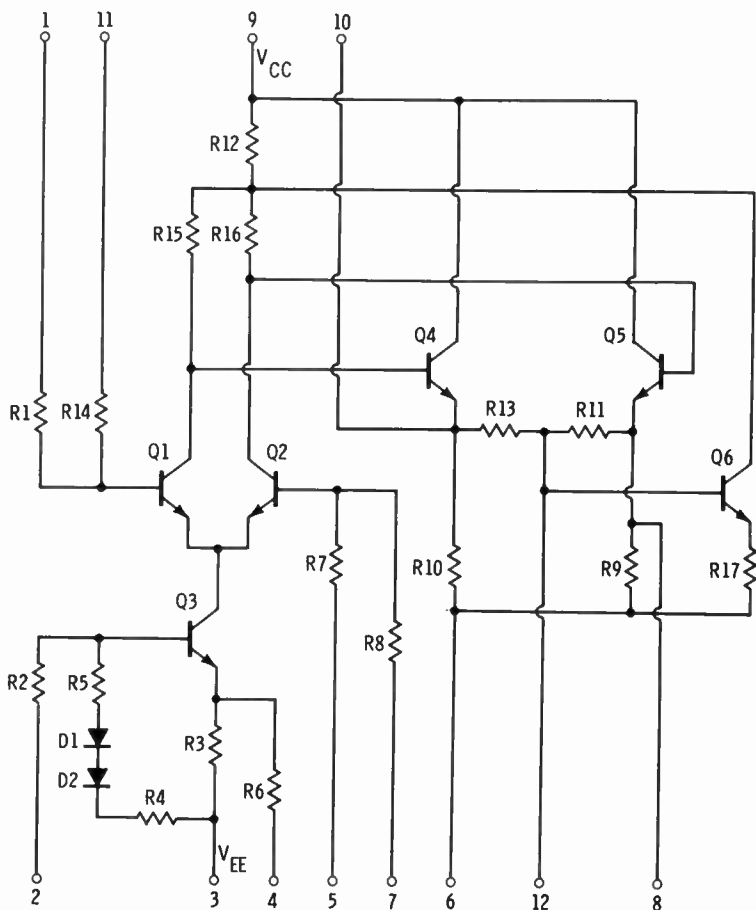

Fig. 3-4. Circuit of the RCA CA 3007 IC used in the preamplifier. (For base connections, see Fig. 1-13, Chapter 1.)

In the preamplifier circuit (Fig. 3-3), the external jumper between IC terminals 6 and 12 connects R9 and R11 in parallel and R10 and R13 in parallel. This allows outboard resistor R1 to serve partially as a common-emitter bias resistor for output transistors Q4 and Q5. The output signal is taken from one emitter-coupled output transistor (Q5).

CONSTRUCTION

The preamplifier is built on 2 $\frac{3}{4}$ -inch x 4 $\frac{3}{4}$ -inch piece of prepunched phenolic board (Allied No. 47 J 0919). Fig. 3-1, 3-2A, and 3-2B show layout of components on this board. All resistors and capacitors are soldered above board to Vector T9.4 push-in terminals (Allied No. 47 J 0878) which are simply pressed into the holes of the board. Potentiometer R2 and the IC socket (Augat 8058, Allied No. 47 J 6087) are mounted in $\frac{3}{8}$ -inch diameter holes drilled in the board. (Switch S1 is part of gain-control potentiometer R1.) All wiring is under the board Fig. 3-2B).

1. Read "Construction Hints" at the end of Chapter 2.
2. Cut a 2 $\frac{3}{4}$ -inch x 4 $\frac{3}{4}$ -inch piece of perforated board.
3. Drill the $\frac{3}{8}$ -inch holes for the socket and potentiometer. It is best to drill the socket hole slightly undersize and then to ream it out carefully until a tight fit is obtained for the socket. If the socket fits loosely, it may be secured in place by means of cement or a $\frac{3}{8}$ -inch inside-star lockwasher.
4. Mount the socket and potentiometer.
5. Press terminals firmly into the holes and turn their slots in the right direction to receive resistor and capacitor leads. For this purpose, insert the terminals so that their broad jaws are above, and their narrow jaws below the board. Mount each pair of terminals so that there are four empty holes between them. This allows good lead length for the resistors and capacitors.
6. Slip the resistor and capacitor leads into the terminals, and solder them using the minimum amount of solder. Observe the correct polarity of the electrolytic capacitors (the positive terminal is marked +).
7. Wire the underside of the board (follow the wiring diagram in Fig. 3-3 and the pictorial diagram in Fig. 3-2B), and solder the leads of the battery clip to the DC-supply terminals above board. Note that the bottom view of the IC socket is given in the layouts, and that terminal 12 is identified by a dot on the Augat socket. For wiring, use a thin, insulated, stranded hookup wire; thicker wire is too large for the closely spaced IC socket ter-

minals. For portions of the wiring that require no insulation (such as jumpers between socket terminals or the common ground bus), use solid tinned No. 22 wire (Belden 8021, Allied No. 55 J 8521).

8. Insert the four mounting screws, one in each corner hole of the board, and secure them with nuts.
9. After all wiring has been double-checked, carefully insert the IC into the socket. Note that terminal 12 is the key tab of the IC can, and that hole No. 12 is marked by a dot on the top of the socket.

TESTING

Test the preamplifier only after all wiring has been verified as correct.

1. Throw switch S1 to its OFF position.
2. Connect the 9-volt battery to the unit by means of the battery plug.
3. Connect an audio oscillator (set to 1 kHz) to the SIGNAL INPUT terminals. Set its output to approximately 20 millivolts rms.
4. Connect an AC VTVM or transistorized voltmeter to the SIGNAL OUTPUT terminals. Set this meter to its 1-volt, 1.5-volt, or 2.5 volt range.
5. Close switch S1 and slowly advance potentiometer R2. The meter should show an audio-output voltage which should increase as R2 is advanced.
6. The vertical-input terminals of an oscilloscope may be connected to the SIGNAL OUTPUT terminals if the waveform of the preamplifier output is to be examined.

USES

This simple preamplifier may be used in any of the conventional applications for such units where a voltage gain of 10 is sufficient. These include speech amplification, modulator driving, CB voice boosting, instrument amplification, and remote control.

Table 3-1. Parts List for Simple Preamplifier

Quantity	Symbol	Allied Catalog Number	Description	Price
1	B	18 J 5154	9-volt transistor battery, Eveready No. 246	\$ 1.30
3	C1, C2 C3	43 J 3346	4.7 μ F 35-DCWV ultraminiature tantalum electrolytic capacitors.	\$ 1.57 ea.
1	IC	50 J 1 CA 3007	Integrated circuit, RCA CA 3007	\$ 5.35
1	R1	45 J 5029 C	5.1K 1/2-watt composition resistor	\$.30
1	R2	46 J 5301	1K potentiometer, IRC Q11-108	\$ 1.23
1	S1	46 J 5359	SPST switch attached to potentiometer, IRC 76-1	\$.75
1		47 J 0919	Vector 64AA18 perforated phenolic board	\$ 1.60
1		47 J 6087	12-contact IC socket, Augat 8058	\$ 9.70 Pkg of 5
10		47 J 0878	Push-in terminals, Vector T9.4	\$ 1.38 per 100
4		47 J 1335	Insulated binding posts, Smith 220	\$.22 ea.
4			6-32 1 1/2-inch round-head machine screws	
4			6-32 1/4-inch hexagonal nuts	
1		47 J 4134	Miniature plastic knob for potentiometer R2, Davies	\$.09
1		18 J 5184	Battery plug, Cinch-Jones 5D	\$ 1.39 Pkg. of 2
Misc.			Insulated stranded hookup wire. Bare tinned solid hookup wire	

CHAPTER 4

HIGH-GAIN PREAMPLIFIER

Constructional details are given here for a high-gain AF preamplifier which provides at least 200 times the voltage gain of the preamplifier described in the preceding chapter. This unit is useful for operation from low-signal devices, such as high quality microphones and sensitive transducers, and for inclusion in sensitive measuring instruments (for example, AC millivoltmeters) and control devices (for example, a DC relay operated from a weak AC signal).

Employing two 6-volt batteries for DC power, this preamplifier has medium-impedance input, low-impedance output, excellent frequency response (DC to 15 MHz if no input and

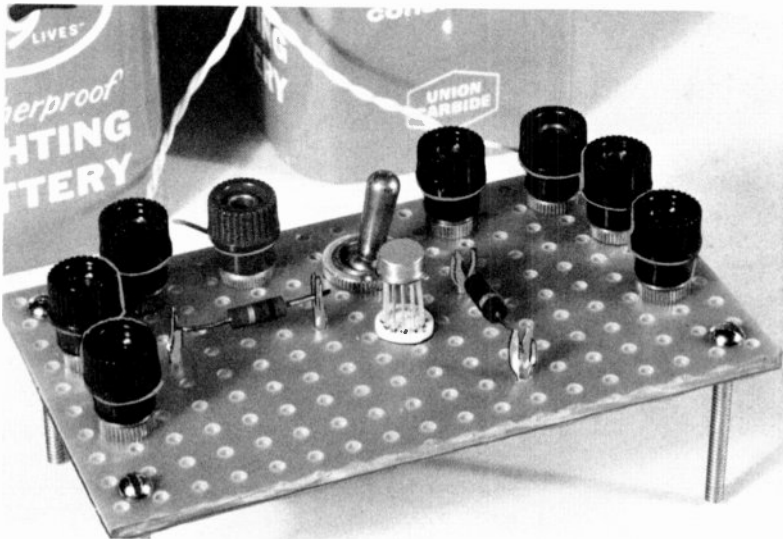
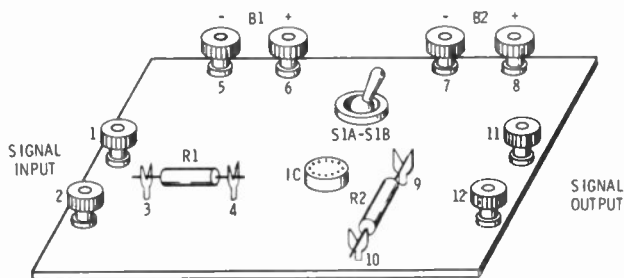

Fig. 4-1. Overall view of the completed high-gain preamplifier.

output coupling capacitors are used), and low current drain. Like the preamplifier described in Chapter 3, this unit is small enough to be installed in close quarters.

DESCRIPTION

Fig. 4-1 is an overall view of the completed preamplifier with the IC plugged in and batteries connected. Figs. 4-2A and 4-2B show the layout of components, and Fig. 4-3 is



(A) Above-board layout.

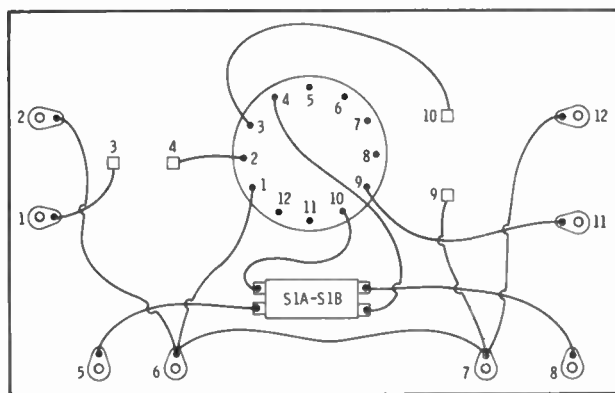

(B) Below-board wiring.

Fig. 4-2. Layout and wiring of the high-gain preamplifier.

the circuit diagram (this circuit is adapted from one recommended by RCA for the IC used). For convenience in understanding the preamplifier circuit, Fig. 4-4 gives the internal circuit of the RCA CA3010 IC used.

This preamplifier (see Fig. 4-3) employs the CA3010 IC with only two outboard components—resistors R1 and R2. If a gain control is desired, a 1000-ohm potentiometer may be connected in the output circuit in the same way shown in Fig. 3-3. If the preamplifier is used without input and output coupling capacitors, its frequency response is flat within 1 dB from DC to 200 kHz. In some applications, however, both capaci-

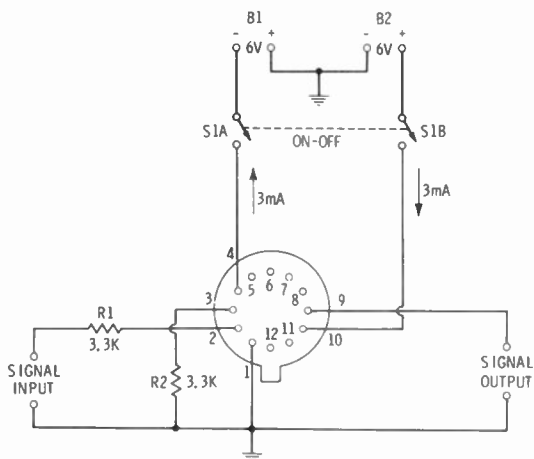

Fig. 4-3. Circuit of the high-gain preamplifier.

tors are needed to protect the circuit from DC voltages in equipment connected to the preamplifier. When this is necessary, large capacitances must be used (1 to $10\mu\text{F}$ and the response will drop, especially at the low-frequency end of the spectrum. (The most vulnerable region is 100 Hz and lower.)

The maximum signal-input voltage before output distortion sets in is 1.5 mV rms, and the corresponding maximum signal-output voltage is 3 volts rms. This corresponds to an open-circuit voltage gain of 2000.

While two 6-volt DC supplies are needed, the circuit is much simpler and more sensitive than it would be with a single supply. The current drawn from each 6-volt battery is 3 mA, under both zero-signal and maximum-signal conditions.

The low-impedance output favors feeding the input signal into a low-impedance line, which practically eliminates hum pickup.

IC EMPLOYED

This preamplifier uses an RCA CA3010 integrated circuit. This IC is an operational amplifier housed in a 12-terminal TO-5 can (see Fig. 1-13 for outline and terminals) and is rated at 14,000 ohms input impedance and 200 ohms output impedance. Its frequency range is given as DC to 15 MHz.

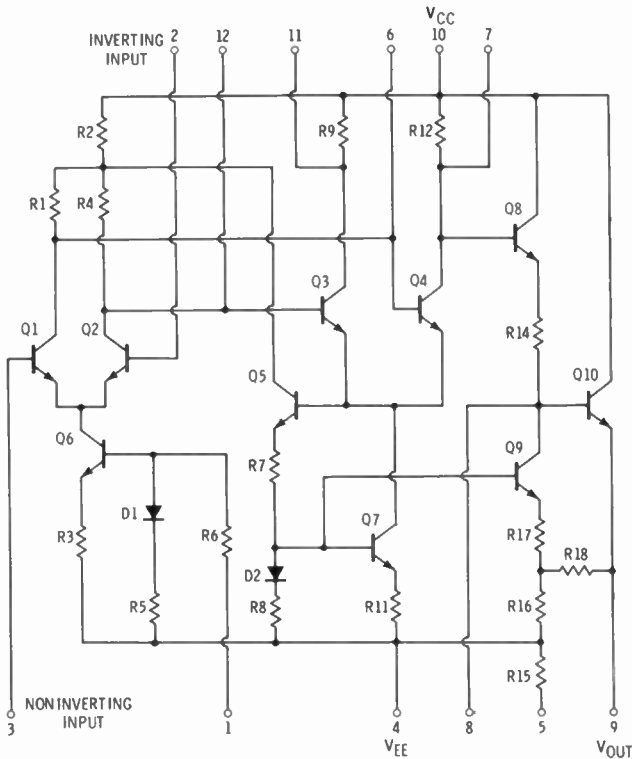

Fig. 4-4. Circuit of the RCA CA 3010 IC used in the high-gain preamplifier. (For base connections, see Fig. 1-3, Chapter 1.)

Fig. 4-4 shows the internal circuit of the CA3010. This unit consists of two cascaded, direct-coupled differential amplifiers (Q1-Q2 and Q3-Q4) direct-coupled to a single-ended emitter-follower output amplifier (Q10). Inverting input is provided by terminal 4 (base of Q2), while noninverting input

is provided by terminal 3 (base of Q1). This means that a positive signal applied to terminal 3 gives a positive-going output signal at terminal 9, whereas a positive signal at terminal 4 gives a negative-going output signal at terminal 9. A positive input signal applied simultaneously to both input terminals results ideally in zero output, since the amplifier system is a balanced one. (Actually, some common-mode error voltage appears at the output, but this, as well as other common-mode effects arising from the DC supply, is reduced by the degeneration produced by transistor Q5.)

In the first differential amplifier stage, a stabilizing current sink is provided by transistor Q6, and temperature stabilization by diode D1; and in the second differential amplifier stage, stabilization is provided by Q7 and D2.

Like other operational amplifiers, the CA3010 is noted for its high gain (here specified by the manufacturer as 60 dB power gain). This suits the unit to applications in which very high gain is imperative, such as those involving large amounts of negative feedback around the amplifier. If a more complete description of this operational-amplifier IC is required, see the RCA integrated-circuit literature.

CONSTRUCTION

The high-gain preamplifier is built on a 2 $\frac{3}{4}$ -inch x 3 $\frac{3}{4}$ -inch piece of perforated phenolic board (Allied No. 47 J 0919). Figs. 4-1, 4-2A, and 4-2B show layout of components of this board. The two resistors are soldered above the board to Vector T9.4 push-in terminals (Allied No. 47 J 0878) which are simply pressed into the holes of the board. The IC socket (Augat 8058, Allied No. 47 J 6087) is mounted in a $\frac{3}{8}$ -inch diameter hole drilled in the board. The DPST ON-OFF toggle switch (S1A-S1B) is similarly mounted in a $\frac{5}{16}$ -inch diameter hole. All wiring is under the board (Fig. 4-2B). Four 1 $\frac{1}{2}$ -inch, 6-32 screws serve as mounting legs.

1. Read "Construction Hints" at the end of Chapter 2.
2. Cut a 2 $\frac{3}{4}$ -inch x 3 $\frac{3}{4}$ -inch piece of perforated board.
3. Drill the $\frac{3}{8}$ -inch hole for the socket and the $\frac{5}{16}$ -inch hole for the switch. It is best to drill the socket hole slightly

undersize and then to ream it out carefully until a tight fit is obtained for the socket. If the socket fits loosely, it may be secured in place by means of cement or a $\frac{3}{8}$ -inch inside-star lockwasher.

4. Drill 8-32 holes for the eight binding posts used for input, output, battery-1, and battery-2 connections.
5. Mount the socket, switch, and binding posts.
6. Press push-in terminals firmly into the holes and turn their slots in the right direction to receive the resistor leads. For this purpose, insert the terminals so that their broad jaws are above, and their narrow jaws below the board. Mount each pair of these terminals so that there are four empty holes between them; this allows good lead length for the resistors.
7. Press the resistor leads into the terminals, and solder them using the minimum amount of solder.
8. Wire the underside of the board (follow the wiring diagram in Fig. 4-3 and the pictorial diagram in Fig. 4-2B). Note that the bottom view of the IC socket is given in the drawings, and that terminal 12 is identified by a dot on the top of the Augat socket. For wiring, use a thin, insulated, stranded hookup wire; thicker wire is too large for the closely spaced IC socket terminals. For those portions of the wiring that require no insulation (such as the common "ground" bus between SIGNAL INPUT and SIGNAL OUTPUT terminals from the bottom of R1 to socket terminal No. 1), use solid, tinned, No. 22 wire.
9. Insert the four mounting screws, one in each corner hole of the board, and secure them with nuts.
10. After the wiring has been double-checked, carefully insert the IC into the socket. Note that terminal 12 is at the key tab of the IC can, and that hole No. 12 is marked by a dot on the top of the socket.

TESTING

Test the preamplifier only after all wiring has been verified as correct.

1. Throw switch S1A-S1B to its OFF position.
2. Connect the two 6-volt batteries to the correct binding posts. Observe correct polarity.
3. Connect an audio oscillator (set to 1 kHz) to the SIGNAL INPUT terminals. Set its output to 1 millivolt rms, or lower. Use the shortest practical leads; otherwise, the preamplifier will pick up noise and hum.
4. Connect an AC VTVM or transistor voltmeter to the SIGNAL OUTPUT terminals. Set this meter to its 3-, 5-, or 10-volt range.
5. Close switch S1A-S1B. The meter should show an audio output voltage which should increase as the oscillator output is advanced.
6. The vertical input terminals of an oscilloscope may be connected to the SIGNAL OUTPUT terminals if the waveform of the preamplifier output is to be examined.

Table 4-1. Parts List for High-Gain Preamplifier

Quantity	Symbol	Allied Catalog Number	Description	Price
2	B1, B2	18 J 5085	6-volt battery, Eveready 510S	\$.92 ea.
1	IC	50 J 1 CA3010	Integrated circuit, RCA CA 3010	\$ 6.60
2	R1, R2	45 J 6045 C	3.3K 1/2-watt composition resistors	\$.24 ea.
1	S1	56 J 4502	DPST toggle switch, Cutler-Hammer 8630K7	\$ 1.14
1		47 J 0919	Perforated phenolic board, Vector 64AA18	\$ 1.60
1		47 J 6087	12-contact IC socket, Augat 8058	\$ 9.70
4		47 J 0878	Push-in terminals, Vector T9.4	Pkg. of 5 \$ 1.38
8		47 J 1335	Insulated binding posts, Smith 220	per 100 \$.22 ea.
4			6-32 1 1/2-inch round-head machine screws	
4			6-32 1/4-inch hexagonal nuts	
			Insulated stranded hookup wire,	
Misc.			Bare tinned solid hookup wire	

USES

This preamplifier may be used in all conventional applications, such as speech and music amplification from low-level microphones. Its high gain suits it to meter amplification, oscilloscope and recorder amplification, and sensitive remote control. This unit is especially advantageous in those applications in which a large amount of external negative feedback is used and the amplifier must have a voltage gain of 60 dB or higher.

CHAPTER 5

QUARTER-WATT AUDIO AMPLIFIER

The small-sized amplifier described in this chapter comfortably delivers $\frac{1}{4}$ watt of audio output to a speaker. With higher battery voltage (up to 9 volts), it will deliver even more power (up to $\frac{1}{2}$ watt). It may be used as a phono amplifier, the entire AF channel in an AM or FM receiver, speech amplifier and modulator in a low-powered transistor transmitter, and in

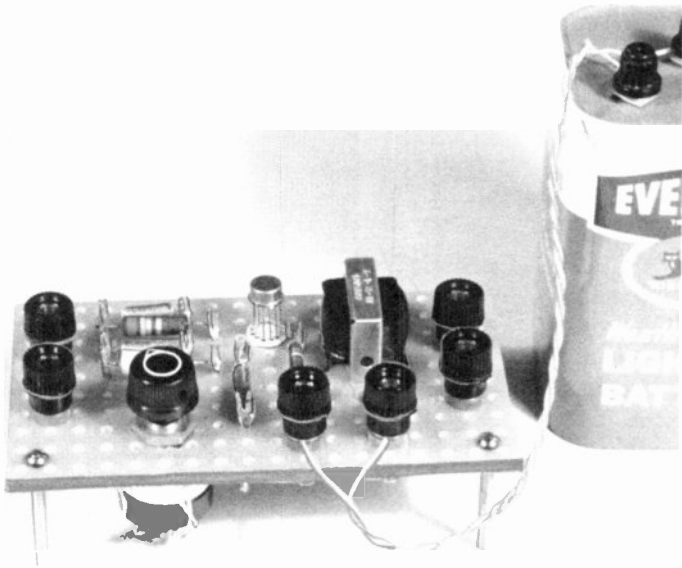
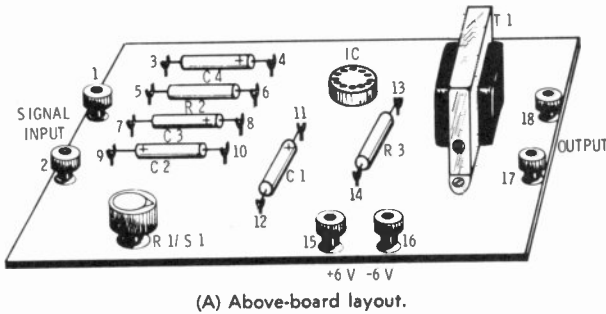

Fig. 5-1. Overall view of the quarter-watt audio amplifier.

any of the other multitude of applications served by a 1/4- to 1/2-watt, battery-operated unit.

DESCRIPTION

Fig. 5-1 is an overall view of the completed amplifier with IC plugged-in and battery connected. Figs. 5-2A and B show layout of the components, and Fig. 5-3 is the circuit diagram.



(A) Above-board layout.

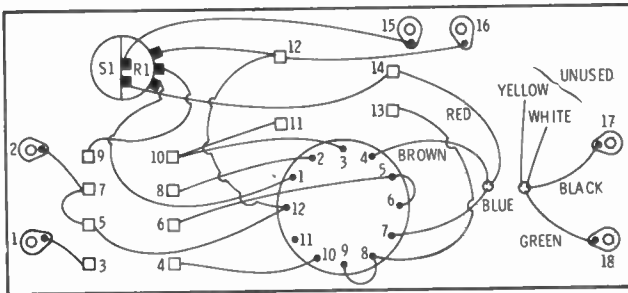

(B) Below-board wiring.

Fig. 5-2. Layout and wiring of the quarter-watt amplifier.

(The circuit is adapted from one recommended by RCA for the IC used.) For convenience in understanding the amplifier circuit, Fig. 5-4 gives the internal circuit of the RCA CA3020 IC used.

In this circuit, the CA3020 is used with eight outboard components: capacitors C1, C2, C3, and C4; resistors R2 and R3; potentiometer R1; and transistor-type output transformer T1. Although the useful frequency range of the CA3020 extends from DC to 8 MHz, it is restricted in this amplifier by

the response of the transformer and by the capacitors. When potentiometer R1 is set for maximum gain, the maximum signal-input voltage before output distortion sets in is 50 mV rms, and the corresponding maximum signal-output power is 250 mW (1/4-watt) into a 4-ohm load. With a single 6-volt

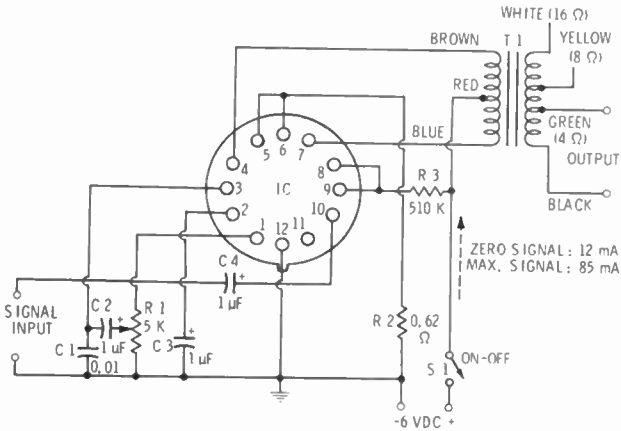

Fig. 5-3. Circuit of the quarter-watt audio amplifier.

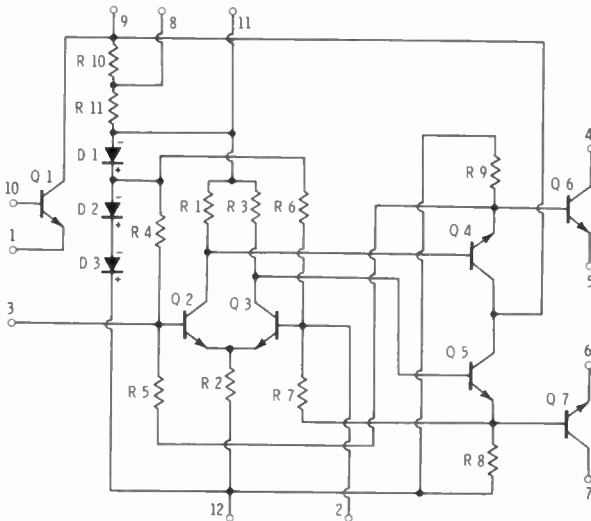

Fig. 5-4. Circuit of the RCA CA 3020 IC used in the quarter-watt amplifier. (For base connections, see Fig. 1-13, Chapter 1.)

DC supply, the current drain is 12 mA at zero signal input, and 85 mA at maximum signal input. Because of the high maximum-signal drain, use of a small transistor-type battery, except for very intermittent service, is not feasible. The $2\frac{5}{8}$ -inch x $2\frac{5}{8}$ -inch x 4-inch lantern-type battery (Eveready 510S, Allied No. 18 J 5085) will supply the current at 6 volts, however, and is shown with the amplifier in Fig. 5-1.

At power outputs of approximately 0.3 watt and higher (battery voltage up to 9 volts), the IC will heat up and may be damaged unless it is cooled by means of a heat sink. A suitable inexpensive sink, which fits on the TO-5 can of the IC, is the Wakefield Type NF 205 (Allied No. 60 J 6529).

IC EMPLOYED

Fig. 5-4 shows the internal circuit of the CA3020. This IC contains a four-stage, stabilized, direct-coupled amplifier. The first stage is a preamplifier comprised of input transistor Q1, the second stage is a phase inverter (Q2 and Q3); the third stage is a push-pull, low-impedance output driver (Q4 and Q5); and the fourth stage is a power output stage (Q6 and Q7). Because the emitter and collector terminals of the latter two transistors are uncommitted inside the IC and are available externally (terminals 4, 5, 6, and 7), the output stage may, by means of external connections, be used push-pull or single-ended. Diodes D1, D2, and D3 provide temperature and supply-voltage stabilization. The frequency response of the basic CA3020 with resistive load is flat within ± 3 db from 10Hz to 6 MHz.

In the $\frac{1}{4}$ -watt amplifier (compare Figs. 5-3 and 5-4), the input signal is applied to terminal 10 (base of transistor Q1), and the gain-control potentiometer (R1) is connected between terminal 1 (emitter of Q1) and ground. This makes an emitter follower out of Q1. Output from the potentiometer is applied to terminal 3 (base of Q2), which is one side of the phase inverter. The power output stage is connected push-pull: The emitters of Q6 and Q7 (terminals 5 and 6) are connected together and to 0.62-ohm emitter resistor R2, and the collectors (terminals 4 and 7) are connected to the outside

terminals of the center-tapped primary winding of output transformer T1.

CONSTRUCTION

The amplifier is built on a $2\frac{3}{4}$ -inch x $4\frac{3}{4}$ -inch piece of pre-punched, perforated phenolic board (Allied No. 47 J 0919), but it can be built much smaller, if desired. Figs. 5-1, 5-2A, and 5-2B show layout of components on this board. All resistors and capacitors are soldered above the board to Vector T9.4 push-in terminals (Allied No. 47 J 0878) which are simply pressed into the holes of the board. Output transformer T1 is mounted above the board (no special holes need be drilled, since the mounting holes in the transformer frame line up with holes in the board). The ON-OFF switch (S1) is a part of gain-control potentiometer R1. This potentiometer and the IC socket (Augat 8058 12-contact, Allied No. 47 J 6087) are mounted in $\frac{3}{8}$ -inch diameter holes drilled in the board.

1. Read "Construction Hints" at the end of Chapter 2.
2. Cut a $2\frac{3}{4}$ -inch x $4\frac{3}{4}$ -inch piece of perforated board.
3. Drill the $\frac{3}{8}$ -inch holes for the socket and potentiometer. It is best to drill the socket hole slightly undersize and then to ream it out carefully until a tight fit is obtained for the socket. If the socket fits loosely, it may be secured by means of cement or a $\frac{3}{8}$ -inch inside-star lockwasher.
4. Drill four 8-32 holes for the INPUT and OUTPUT binding posts.
5. Mount the socket and potentiometer.
6. Mount the transformer with two 5-40 screws and nuts. Pass its primary and secondary leads through nearby holes in the board.
7. Mount the binding posts.
8. Press push-in terminals for the resistors and capacitors firmly into the holes and turn slots in the right direction to receive the leads of these components. For this purpose, insert the terminals so that their broad jaws are above, and their narrow jaws below the board. Mount each pair of terminals so that there are four

empty holes between them. This allows good lead length for the resistors and capacitors.

9. Slip the resistor and capacitor leads into the terminals and solder them using the minimum amount of solder. Observe the correct polarity of the electrolytic capacitors (the positive terminal is marked +).
10. Wire the underside of the board (follow the wiring diagram in Fig. 5-3 and the pictorial diagram in Fig. 5-2B). Note that the bottom view of the IC Socket is given in the drawings and that terminal 12 is marked with a dot on the Augat socket. For wiring, use a thin, insulated, stranded hookup wire; thicker wire is too large for the closely spaced socket terminals. For portions of the wiring that require no insulation (such as jumpers between socket terminals, or the common bus), use solid, tinned, No. 22 wire. In wiring the transformer, follow the color coding of leads indicated in Fig. 5-3. This transformer has 4-, 8-, and 16-ohm outputs. The black and green secondary leads, shown in Fig. 5-3, provide 4-ohm output; for 8 ohms use black and yellow, and for 16 ohms use black and white. The unused leads should either be clipped off or rolled up and tucked to one side below the board.
11. Insert the four mounting screws, one in each corner hole of the board, and fasten them with nuts.
12. After all wiring has been double-checked, carefully insert the IC into the socket. Note that terminal 12 is at the key tab of the IC can, and that hole No. 12 is marked by a dot on the top of the socket.

TESTING

Test the amplifier only after all wiring has been verified as correct, and never operate the amplifier unless it is terminated in its load.

1. Throw switch S1 to its OFF position.
2. Connect the 6-volt battery to the +6 and -6 binding posts.
3. Connect an audio signal source (oscillator, record player,

microphone, etc.) to the SIGNAL INPUT terminals. The output of this device should not exceed 50 mV.

Table 5-1. Parts List for the Quarter-Watt Audio Amplifier

Quantity	Symbol	Allied Catalog Number	Description	Price
1	B1	18 J 5085	6-volt lantern-type battery, Eveready 510S	\$.92
1	C1	43 J 4419	0.01- μ F miniature metallized capacitor, Cornell-Dubilier MMW or equivalent	\$.66
3	C2, C3 C4	43 J 1784	1- μ F 50-DCWV miniature electrolytic capacitor, Sprague TE1300	\$.54
1	IC	50 J 1 CA3020	Integrated circuit, RCA CA 3020	\$ 2.56
1	R1	46 J 5383	5000-ohm potentiometer IRC Q13-114	\$ 1.23
1	R2	45 J 5078 C	0.62-ohm 2-watt wirewound resistor	\$.48
1	R3	45 J 7155 C	510K $\frac{1}{2}$ -watt composition resistor	\$.90
1	S1	46 J 5359	SPST switch attached to potentiometer R1, IRC type 76-1	Card of 10 \$.75
1	T1	54 J 2365	Miniature transistor-type output transformer (Pri. 100 ohms C.T., sec. 4, 8, 16 ohms), Knight 6-T-35	\$ 4.16
1		47 J 0919	Perforated phenolic board, Vector 64AA18	\$ 1.60
1		47 J 6087	12-contact IC socket, Augat 8058	\$ 9.70
12		47 J 0878	Push-in terminals, Vector T9.4	Pkg. of 5 \$ 1.38
6		47 J 1335	Insulated binding posts, Smith 220	per 100 \$.22 ea.
4			6-32 $\frac{1}{4}$ -inch round-head machine screws	
4			6-32 $\frac{1}{4}$ -inch hexagonal nuts	
2			5-40 $\frac{1}{4}$ -inch round-head machine screws	
2			5-40 $\frac{1}{4}$ -inch hexagonal nuts	
1		47 J 4144	Miniature plastic knob for potentiometer	\$.14
Misc.			Insulated stranded hookup wire	
			Bare tinned solid hookup wire	

4. Connect a speaker to the OUTPUT terminals. The impedance of this speaker must match that of the selected output impedance of transformer T1.
5. With the signal source operating, slowly advance the potentiometer after switching on the DC power. The speaker should now begin operating and its response should grow louder as R1 is advanced.
6. For other tests, such as waveform, bandwidth, gain, and noise the speaker may be replaced with a 2-watt resistor having the same resistance as the speaker impedance.

USES

Since this little amplifier contains preamplifier, phase-inverter, driver, and power-output stages, it immediately finds such obvious use as phono amplifier, audio channel of a receiver, driver for a higher-powered amplifier, speech amplifier/modulator channel of a low-powered transmitter, intercom, and power-developing preamplifier feeding a low-impedance line. But it finds other practical applications, as well: With a rectifier-type meter in place of the speaker, the amplifier may be used as a signal tracer, AC millivoltmeter, sound-level meter, applause meter, and vibration meter. And with a rectifier-type relay in place of the speaker, it becomes a sensitive AC relay. Two identical amplifiers may be built for stereo use.

Higher power output may be obtained from the amplifier with no more complication than increasing the battery voltage. Up to 9 volts may be used, and RCA specifies 0.545 watt (at 10 percent total harmonic distortion) into an 8-ohm load as power output for that voltage. At this power level, however, the IC will heat up and it must be cooled by means of a metal-fin heat sink, as explained earlier.

CHAPTER 6

FREQUENCY-STANDARD CRYSTAL OSCILLATOR

Only two outboard resistors, one capacitor, and a quartz crystal converts a DC-amplifier type IC into an unusually vigorous, multivibrator-type, low-frequency (up to 1 MHz) oscillator. The oscillator, which is described below, is a simple circuit, the output of which is rich in harmonics. It may be used as a spot-frequency RF alignment generator or as a secondary frequency standard. It may also be used in radio-control work.

This unit has the advantage over a single-transistor crystal oscillator in that its harmonic output is much greater than

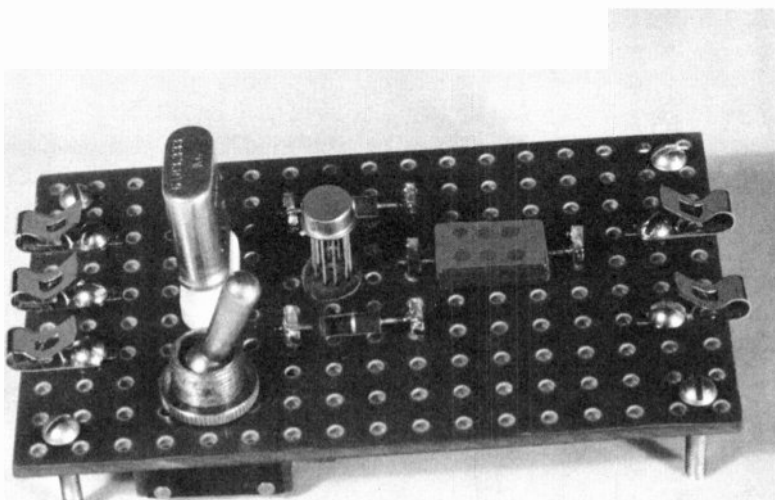

Fig. 6-1. Overall view of the completed crystal oscillator.

Frequency-Standard Crystal Oscillator

with the simpler circuit, so no auxiliary wave-distorting circuit is needed. In spite of the fact that the IC contains four transistors, the DC drain of the oscillator is low: 3 mA from one 6-volt battery, and 2.6 mA from the other.

DESCRIPTION

Fig. 6-1 shows the completed oscillator with IC plugged in. Figs. 6-2A and 6-2B show the layout of components, and wir-

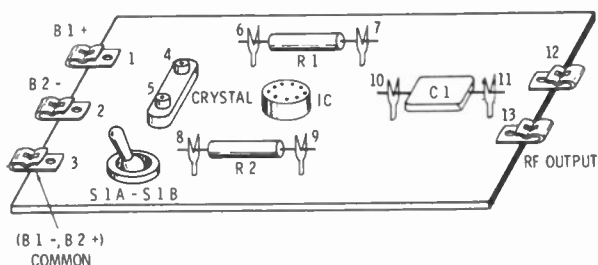

(A) Above-board layout.

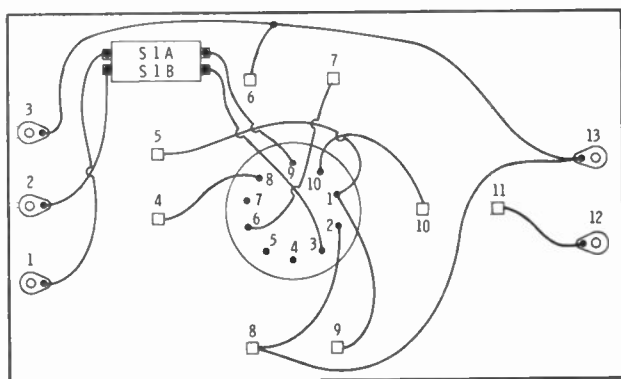

(B) Below-board wiring.

Fig. 6-2. Layout and wiring of the crystal oscillator.

ing; Fig. 6-3A is the circuit diagram; and Fig. 6-3B shows the waveform of the signal-output voltage. For convenience in understanding the oscillator circuit, Fig. 6-4 gives the internal circuit of the RCA CA3000 integrated circuit employed in this project.

This oscillator uses three outboard components with the CA3000: capacitor C1 and resistors R1 and R2. It employs two DC supplies (B1 and B2), each 6 volts. The current drain from B1 (the V_{cc} supply) is 2.6 mA, and from B2 (the V_{ee} supply) is 3 mA. Each of these currents is low enough to be

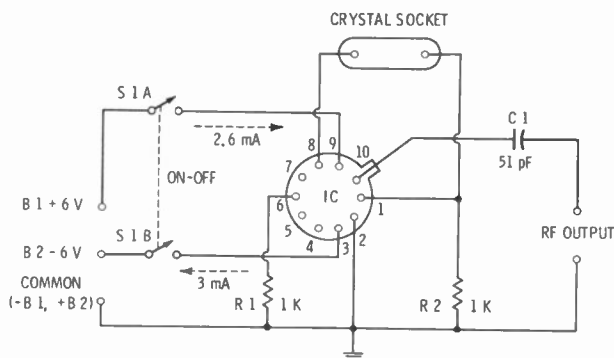

(A) Circuit of oscillator.

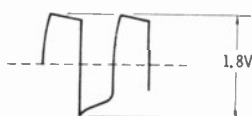

(B) Output waveform.

Fig. 6-3. Crystal oscillator circuit and waveform of output.

supplied easily by series-connected size-C or size-D flashlight cells, or by one single, small-sized 5.4-volt battery, such as Mallory TR114RT2 (Allied No. 18 J 5895). The DPST ON-OFF switch, S1A-S1B, disconnects both batteries in the OFF position. This circuit has been adapted from a basic one recommended by RCA for the CA3000 integrated-circuit used.

Fig. 6-3B shows the rectangular waveform of the RF output signal. At 100 kHz, this signal has a peak-to-peak amplitude of 1.8 volts; and this level is ample for secondary frequency-standard purposes, since the 100-kHz harmonics may be picked up as far as 30 MHz and somewhat beyond. For some applications, especially those involving sensitive receivers or detectors, the direct connection between the OUTPUT terminals

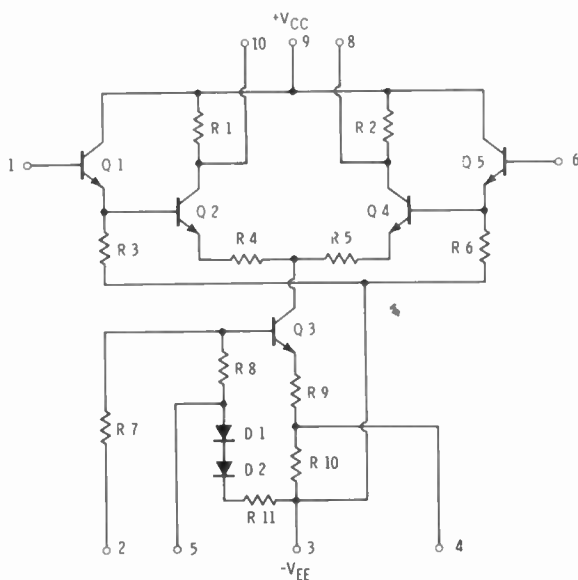

Fig. 6-4. Circuit of the RCA CA 3000 IC used in the crystal oscillator.

and a device under test may be eliminated and adequate coupling obtained from a short antenna connected to the "high" OUTPUT terminal.

IC EMPLOYED

Fig. 6-4 shows the internal circuit of the CA 3000 used in the oscillator. This is a DC-amplifier type IC containing two separate direct-coupled stages (Q1-Q2 and Q4-Q5) and housed in a 10-terminal TO-5 can (see Fig. 1-11, Chapter 1, for outline, terminals, and dimensions). On the left side of the circuit, Q1 is an input emitter follower which is direct-coupled to Q2, a high-gain common emitter. On the right side of the circuit, Q5 is the corresponding input emitter follower, and Q4 the high-gain output common emitter. This is essentially a differential amplifier arrangement in which transistor Q3, diodes D1 and D2, and their associated resistors (R8-R11) form a stabilizing current sink. The input impedance of the CA3000 is given as 195,000 ohms, and the output impedance as 8000 ohms.

Note that in the oscillator circuit (Fig. 6-3A), the crystal is connected between the base of input transistor Q1 (terminal 1) and the collector of output transistor Q4 (terminal 8). This provides a feedback path, through the crystal, from the right-side output to the left-side input. This arrangement of the components converts the IC into an emitter-coupled multivibrator, the operating frequency of which is determined principally by the crystal, and it is the multivibrator action which gives the nonsinusoidal output waveform shown in Fig. 6-3B. A signal of this sort, being rich in harmonics, is desirable for standard-frequency oscillator work. With external clipping provided by a simple diode circuit, the circuit may also be used as a single-frequency square-wave generator.

If it is desired to adjust the crystal frequency closely to zero beat with a standard-frequency source (such as WWV transmissions), a 20-pF midget variable capacitor may be connected in parallel with the crystal socket for that purpose.

CONSTRUCTION

The oscillator is built on a 2 $\frac{5}{8}$ -inch x 4 $\frac{1}{2}$ -inch piece of perforated phenolic board (Allied No. 47 J 0919). Fig. 6-1, 6-2A, and 6-2B show layout of components on this board. The capacitor and resistors are soldered above board to Vector T9.4 push-in terminals (Allied No. 47 J 0878) which are simply pressed into the holes of the board. The IC socket (Cinch-Jones 10-ICS, Allied No. 47 J 0195) is mounted in a $\frac{3}{8}$ -inch diameter hole notched as shown in Fig. 2-3. The DPST toggle switch (S1A-S1B) is mounted in a $\frac{5}{16}$ -inch diameter hole. Small Fahnestock clips (Allied No. 47 J 1707) are provided for output and battery connections. A standard ceramic crystal socket (Allied No. 47 J 5542) is used. This socket is held to the board by one central 5-40 screw and nut. All wiring is under the board (Fig. 6-2B.)

The unit is supported by four $\frac{3}{4}$ -inch 6-32 screws which serve either as legs, or (if the unit is enclosed in a case) as stand-off screws.

1. Read "Construction Hints" at the end of Chapter 2.
2. Cut a 2 $\frac{5}{8}$ -inch x 4 $\frac{1}{2}$ -inch piece of perforated board.

3. Drill the $\frac{3}{8}$ -inch hole for the IC socket. Follow the instruction given in Fig. 2-3 and the accompanying discussion.
4. Drill the $\frac{5}{16}$ -inch hole for the switch.
5. Drill $\frac{1}{4}$ -inch clearance holes for the lug terminals of the crystal socket. Space them on each side of one of the board holes which will be used for the single screw which holds the crystal socket.
6. Mount the IC socket (see directions in Fig. 2-3, Chapter 2).
7. Mount the crystal socket, using a single 5-40 screw and nut.
8. Mount the Fahnestock clips, using $\frac{1}{4}$ -inch 6-32 screws and nuts. Mount the three DC-supply clips with one empty board hole between them; mount the two OUTPUT clips with two empty holes between them.
9. Press the push-in terminals into the holes and turn their slots in the right direction to receive the resistor and capacitor leads. For this purpose, insert the terminals so that their broad jaws are above, and their narrow jaws below the board. Mount each pair of terminals so that there are four empty holes between them; this allows good lead length for the capacitor and resistors.
10. Slip the resistor and capacitor leads into the terminals and solder them, using the minimum amount of solder.
11. Wire the underside of the board (follow the diagram in Fig. 6-3A and the pictorial diagram in Fig. 6-2B). Note that the bottom view of the IC socket is shown in the drawings, and that terminal 10 is marked both by the key tab of the IC can and the ridge of the socket. For wiring, use a thin, insulated, stranded hookup wire; thicker wire is too large for the closely spaced socket terminals. For portions of the wiring which require no insulation (such as the common ground bus), use solid tinned No. 22 wire.
12. Insert the four mounting screws, one in each corner hole of the board, and secure them with nuts.
13. After all wiring has been double-checked, carefully insert the IC into the socket. Note that terminal 10 is at the

key tab of the IC can and should be inserted into the hole located at the ridge of the socket.

Table 6-1. Parts List for Crystal Oscillator

Quantity	Symbol	Allied Catalog Number	Description	Price
1	C1	43 J 4179	51-pF silver mica capacitor, Cornell-Dubilier CM or equivalent	\$.18
1	IC	50 J 1 CA3000	Integrated circuit, RCA CA 3000	\$ 3.80
2	R1, R2	45 J 6045	1000-ohm composition resistors	\$.24 ea.
1	S1A, S1B	56 J 4502	DPST toggle switch, 8360 K7	\$ 1.14
1		47 J 0919	Perforated phenolic board, Vector 64AA18	\$ 1.60
1		47 J 0195	10-contact IC socket, Cinch-Jones 10-ICS	\$.72
1		47 J 5542	Crystal socket, Elco 05	\$.66
6		47 J 0878	Push-in terminals, Vector T9.4	\$ 1.38
5		47 J 1707	Small Fahnestock clips	\$.20 Per 100
4			6-32 3/4-inch round-head machine screws	Per pkg. of 10
5			6-32 1/4-inch round-head machine screws	
9			6-32 1/4-inch hexagonal nuts	
1			Quartz crystal for desired frequency	
Misc.			Small insulated stranded hookup wire	
			Bare tinned solid hookup wire	

TESTING

Test the oscillator only after all wiring has been verified as correct.

1. Throw switch S1A-S1B to its OFF position.
2. Connect two 6-volt (or alternatively, two 5.4-volt) batteries to the + 6 V, - 6 V, and COMMON clips. (The COMMON clip receives the negative lead of the positive battery, and the positive lead of the negative battery.)

3. Plug a crystal into the crystal socket.
4. Connect an oscilloscope or an AC VTVM (or transistorized voltmeter) set to its 5- or 10-volt range, or both, to the OUTPUT clips.
5. Close switch S1A-S1B. The meter should show a deflection, or the oscilloscope should display the rectangular-wave signal. Check the voltage and waveform, as desired.
6. In the absence of a VTVM or oscilloscope, the oscillator signal may be picked up on a receiver tuned to the crystal frequency or one of its harmonics.

USES

This stable oscillator may be used as a secondary frequency standard (100 kHz or 1 MHz) or as a single-frequency oscillator for circuit alignment, frequency spotting, signal injection, time-mark generation, low-frequency radio control, transmission in a metal locator, etc.

CHAPTER 7

AF/RF SIGNAL TRACER

A signal tracer is one of the most useful and versatile instruments for electronic troubleshooting. As every serviceman knows, it can quickly localize the defective part of a circuit. The technique of troubleshooting by signal tracing is so well-known that it needs no recapitulation here.

The signal tracer described in this chapter exploits the compactness of an audio-frequency IC. Because the instrument is battery-operated, it offers complete portability, cool operation, instant performance, and freedom from power-line hum interference. It gives audible (speaker), and visual

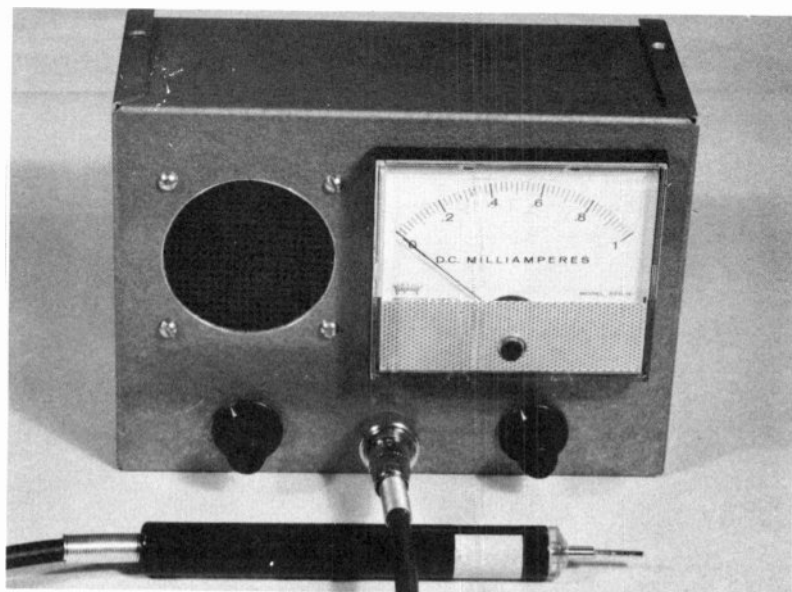

Fig. 7-1. Overall view of the AF-RF signal tracer.

(meter) indications. (A milliammeter, rather than the usual delicate microammeter, is used.) By means of separate probes, operation is provided on AF and modulated-RF signals. A front-panel switch allows the speaker to be cut out when silent operation is preferred.

Although this signal tracer can be held in one hand, it could be made still smaller. It is both sensitive and rugged.

DESCRIPTION

Fig. 7-1 is an outside, overall view of the signal tracer with one of the two test probes plugged in. Fig. 7-2 shows the inside

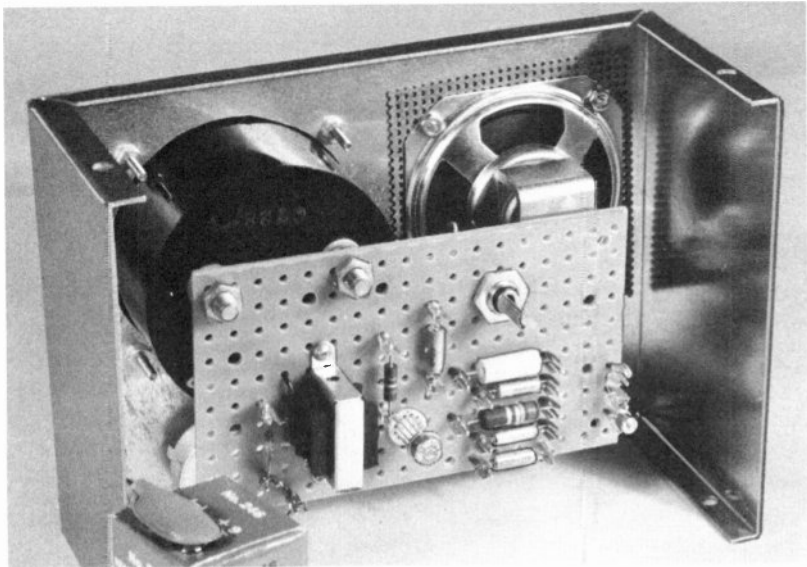

Fig. 7-2. Inside view of the signal tracer.

of the instrument (the self-contained battery stands to the left, front). Fig. 7-3 gives the complete drilling plan for the front panel. Fig. 7-4 is the circuit diagram. Figs. 7-5A and 7-5B show the layout of components and wiring of the circuit board; and Fig. 7-6 shows the mounting and wiring of components on the front panel.

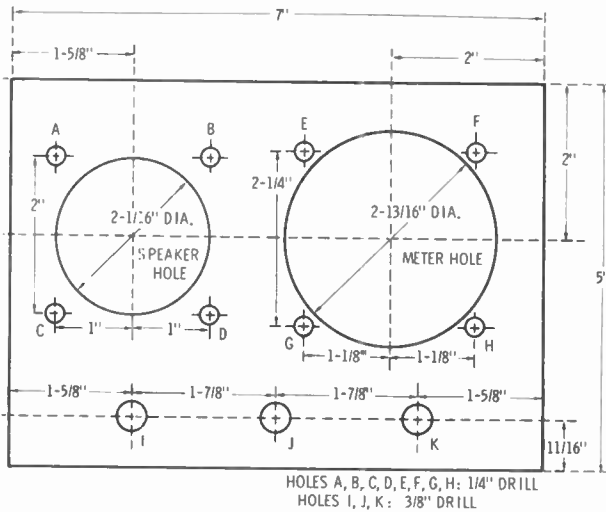

Fig. 7-3. Front-panel drilling plan for the signal tracer.

This instrument is built in a 7-inch x 5-inch x 3-inch gray hammertone aluminum box (Bud CU-2108-A *Minibox*, Allied No. 42 J 7624). The meter is a 3½-inch rectangular 0-1 DC milliammeter (Triplet 320-G, Allied No. 55 J 6635) and the speaker a 2½-inch square unit (Utah SP25A, Allied No. 16 J 3500). The circuit is wired on a 2¾-inch x 4¾-inch perforated board which is supported by the two ¼-inch terminal screws on the back of the meter (Fig. 7-2). All components are on this board, except gain-control potentiometer R1, speaker switch S2, and input jack J1, which are on the front panel. (In Fig. 7-1, the speaker switch is under the speaker, and the gain control is under the meter.)

The circuit (Fig. 7-4) is that of a high-gain AF amplifier with push-pull power-output transformer coupled into the speaker and meter circuit. The speaker signal is in excess of 0.4 watt, with approximately 50 mW input at jack J1, and this signal deflects the meter to full scale when potentiometer R1 is set for maximum gain. The RCA CA3020 IC supplies all of the basic amplifier stages (see Fig. 5-4, Chapter 5, for the internal circuit of this IC which provides the following stages: input preamplifier, phase inverter, push-pull driver, and push-

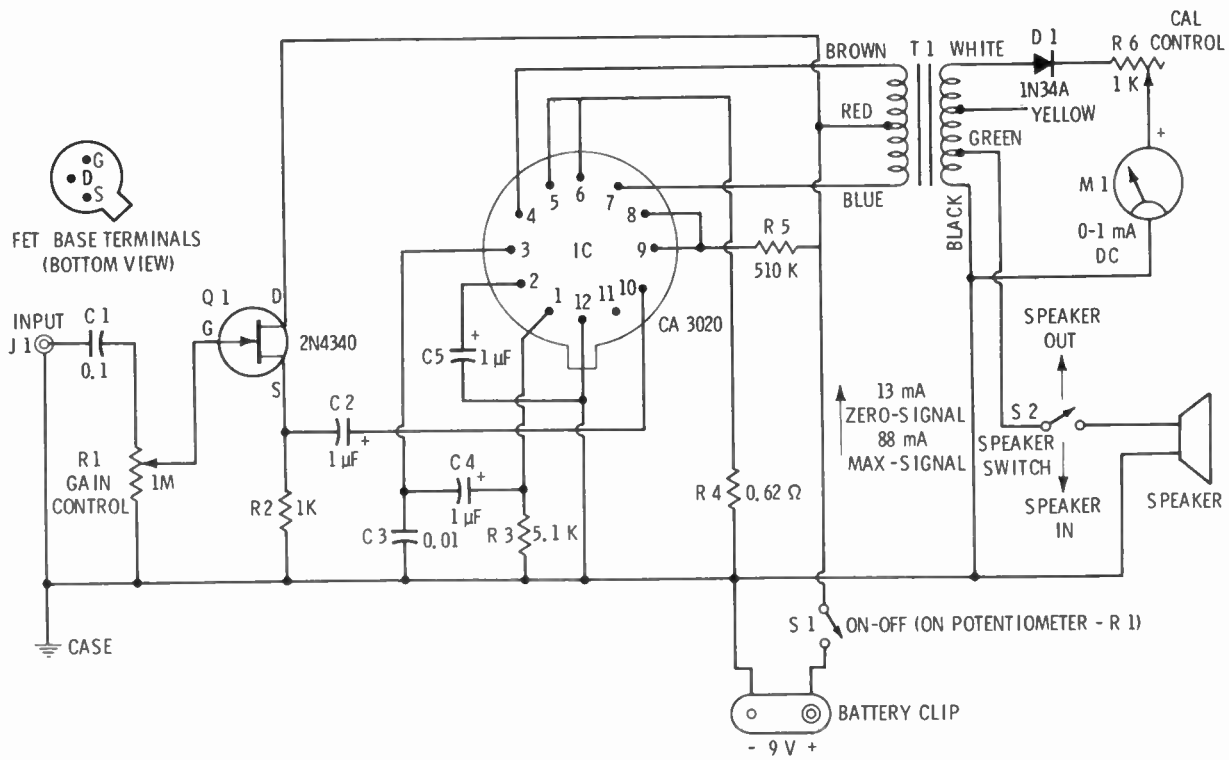
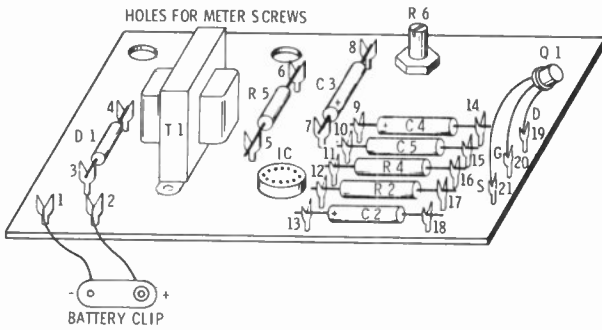
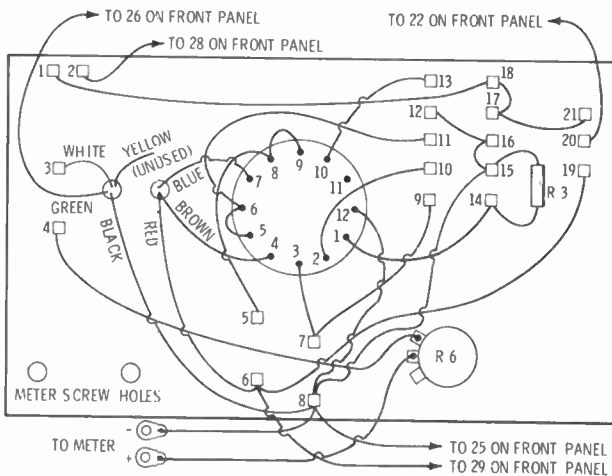

Fig. 74. Circuit of the signal tracer.





(A) Above-board layout.



(B) Below-board wiring.

Fig. 7-5. Layout and wiring of the signal tracer.

pull power output). An outboard 2N4340 field-effect transistor (FET), Q1, has been inserted as a source-follower between input jack J1 and the IC, to provide high input impedance for negligible loading of a circuit under test. (The net input impedance is approximately 1-megohm, the resistance of potentiometer R1.) The leads of the FET are soldered to three push-in terminals on the board (Fig. 7-5A); no transistor socket is required. The circuit draws 13 mA at zero signal, and 88 mA at maximum signal. At this drain, the heavy-duty 9-volt transistor battery seen in Fig. 7-2 (Eveready No. 246, Allied

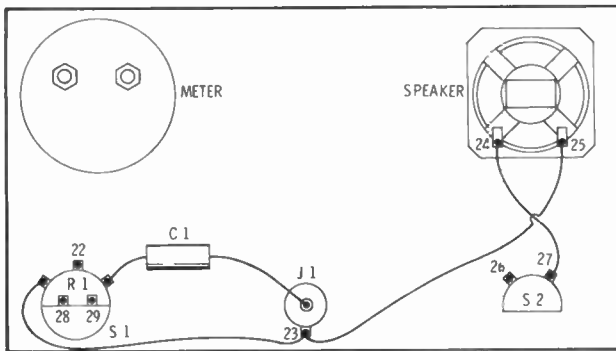

Fig. 7-6. Components and wiring on front panel.

No. 18 J 5154) will be satisfactory for short runs; but for prolonged use of the signal tracer, a heavier-duty, rechargeable battery is advised (for example, General Electric 6.25-volt nickel-cadmium battery, Allied No. 18 J 5120).

The AF output signal is rectified by germanium diode D1 (Sylvania IN34A, Allied No. 49 J 12 1N34A-SYL), and the resultant direct current deflects the 0-1 DC milliammeter (M1). The 1000-ohm wirewound rheostat (R6) is the CALIBRATION CONTROL, which allows the meter to be set to full-scale with a measured signal-input voltage. Since it need not be touched after adjustment, this rheostat is provided with a slotted shaft for screwdriver adjustment and is mounted on the circuit board inside the instrument case, where it will be protected from tampering. SPST rotary, phono-radio-type switch S2 (Centralab 1460, Allied No. 56 J 4080) allows the speaker to be switched off for the meter indication only.

The input jack (J1) is a concentric chassis receptacle (Amphenol 75-PC-1M, Allied No. 47 J 1965). This jack accepts a mating plug (Amphenol 75-MC-1F, Allied No. 47 J 1958). The signal from a suitable shielded test probe is applied at this jack. For this purpose, a direct-input probe (EICO PDK, Allied No. 21 J 4153) is used for AF signals, and a demodulator probe (EICO PSDK, Allied No. 21 J 4151) is used for amplitude-modulated signals. Both probes and their cables are supplied in kit form and must have the Amphenol plugs, mentioned above, attached to their cables.

The output transformer (T1) is a miniature, transistor-type unit (Knight 6-T-35 HF, Allied No. 54 J 2365). Its 8-ohm yellow lead is the only one of the secondary leads which is unused. No special holes need be drilled for this transformer, since its own mounting holes line up with those of the perforated board.

IC EMPLOYED

The RCA CA3020 integrated circuit used in the signal tracer is housed in a 12-terminal TO-5 can (see Fig. 1-13, Chapter 1, for outline and terminals). This IC is a complete amplifier, from preamplifier stage to push-pull power output stage, and is described fully under "IC Employed" in Chapter 5.

CONSTRUCTION

The main circuit is assembled on a 2 $\frac{3}{4}$ -inch x 4 $\frac{3}{4}$ -inch piece of perforated phenolic board (Allied No. 47 J 0919). Figs. 7-1, 7-5A, and 7-5B show layout of components on this board. All resistors and capacitors except R3, as well as diode D1 and transistor Q1, are soldered above board to Vector T9.4 push-in terminals (Allied No. 47 J 0878) which are simply pressed into the holes of the board. Resistor R3 is soldered between terminals 14 and 15 under the board, as shown in Fig. 7-5B. Potentiometer R6 and the IC socket (Augat 8058, Allied No. 47 J 6087) are mounted in $\frac{3}{8}$ -inch diameter holes drilled in the board. The board is held by the terminal screws of the meter. All wiring is under the board. On the front panel are mounted potentiometer R1 (and its ON-OFF switch, S1), input jack J1, meter M1, speaker SPKR, and speaker switch S2. Numbers on Figs. 7-5B and 7-6 show how connections are made between the board and these components.

1. Read "Construction Hints" at the end of Chapter 2.
2. Drill the front panel of the *Minibox*, using the plan given in Fig. 7-3.
3. Cut a 3-inch x 3-inch piece of finely perforated phenolic board to serve as the speaker grille. Drill four No. 6

corner mounting holes to line up with the speaker mounting holes.

4. Mount the meter, speaker, grille, potentiometer/switch R1/S1), input jack, and speaker switch S2 on the front panel.
5. Wire the front panel, as shown in Fig. 7-6.
6. Assemble and wire the two test probes, attaching a concentric plug on the end of each shielded cable (one plugged-in probe is shown in Fig. 7-1).
7. Cut a $2\frac{3}{4}$ -inch x $4\frac{3}{4}$ -inch piece of perforated board.
8. Drill the $\frac{3}{8}$ -inch holes for the socket and rheostat R6. It is best to drill the socket hole slightly undersize and then to ream it out carefully, until a tight fit is obtained for the socket. If the socket fits loosely, it may be secured in place by means of cement or a $\frac{3}{8}$ -inch inside-star lockwasher.
9. Drill two $\frac{1}{4}$ -inch diameter clearance holes ($1\frac{1}{4}$ -inch apart) in the upper-left section of the board to accommodate the meter screws (Fig. 7-5A).
10. Mount the socket and rheostat on the board.
11. Mount the transformer, using two 5-40 screws and nuts.
12. Press push-in terminals firmly into the holes and turn their slots in the right direction to receive resistor, capacitor, diode, and transistor leads. For this purpose, insert the terminals so that their broad jaws are above, and narrow jaws below the board. Mount each pair of resistor, capacitor, and diode terminals so that there are two empty holes between them; mount the three terminals for the transistor without any empty holes between them.
13. Slip the component leads into the terminals, and solder them, using the minimum amount of solder. Do not insert the transistor yet. Observe the correct polarity of the diode and of the electrolytic capacitors. Observe the color coding of the transformer leads.
14. Wire the underside of the board (follow the wiring diagram in Fig. 7-4 and the pictorial diagram in Fig. 7-5B), and wire the battery clip to terminals 1 and 2 above the board (observe correct polarity of the clip). Note that the bottom view of the socket is given in the layouts,

and that terminal 12 is identified by a dot on the Augat socket. For wiring, use a thin, insulated, stranded hookup wire; thicker wire is too large for the closely-spaced IC socket terminals. For portions of the wiring which require no insulation (such as jumpers between socket terminals, and the common ground bus), use solid, tinned, No. 22 wire.

15. Complete the wiring by running insulated leads between the circuit board and the front-panel components. Follow the number coding given in Figs. 7-5B and 7-6.
16. Solder the transistor to the three push-in terminals (19, 20, and 21). To prevent heat damage to the transistor, grip the lead firmly with long-nose pliers at a point between the soldered joint and the transistor case, and continue to grip it until the joint has completely cooled.
17. After all wiring has been double-checked, carefully insert the IC into its socket. Note that terminal 12 is at the key tab of the IC can, and that hole 12 is marked by a dot on the top of the socket.
18. Attach the lug-terminated leads (from terminal 8 and rheostat R6) to the meter screw terminals.
19. Mount the circuit board on the back of the meter by slipping the clearance holes over the meter screws. Tighten the meter nuts to secure the board in place.

TESTING

Test the signal tracer only after all wiring has been verified as correct.

1. Throw switch S1 to its OFF position.
2. Set rheostat R6 to its maximum-resistance position.
3. Throw switch S2 to its SPEAKER IN position.
4. Connect the direct probe to jack J1.
5. Connect an audio oscillator (set to 1 kHz and 50 mV output) to the probe.
6. Clip in the battery.
7. Throw switch S1 to its ON position and slowly advance potentiometer R1, noting that the speaker signal appears and increases in volume as R1 is advanced.

8. At the full-gain setting of R1, adjust rheostat R6 to bring the meter deflection exactly to full scale.
9. Throw switch S2 to its SPEAKER OFF position, to check that it does cut the speaker out. Then, return S2 to its SPEAKER IN position.
10. Remove the audio oscillator, and exchange the demodulator probe for the direct probe. Connect the probe to the output of an amplitude-modulated RF oscillator (signal generator) set to 1 MHz and approximately 50 mV output. Repeat steps 7, 8, and 9.

Table 7-1. Parts List for the Signal Tracer

Quantity	Symbol	Allied Catalog Number	Description	Price
1	B	18 J 5154	9-volt transistor battery, Ever-ready No. 246	\$ 1.30
1	C1	43 J 5122	0.1- μ F 200-volt Mylar tubular capacitor, Sprague 2TM	\$.24
2	C2, C4	43 J 5839	1- μ F 20-DCWV ultra-miniature tantalum electrolytic capacitor	\$ 1.22
1	C3	43 J 4419	0.01- μ F miniature metallized capacitor	\$.66
1	D1	49 J 12 1N34A Syl.	1N34A general-purpose germanium diode	\$.30
1	IC	50 J 1 CA3020	Integrated circuit, RCA CA 3020	\$ 2.56
1	J1	47 J 1965	Concentric chassis receptacle. Amphenol 75-PC-1M	\$.41
1	M1	52 J 6635	0-1 DC milliammeter, Triplett 320-G	\$17.50
1	Q1		Field-effect transistor, Siliconix 2N4340	
1	R1	46 J 5326	1-megohm potentiometer, IRC Q13-137, with SPST switch	\$ 1.23
1	R2	45 J 6045	1K $\frac{1}{2}$ -watt composition resistor	\$.24
1	R3	45 J 6045	5.1K $\frac{1}{2}$ -watt composition resistor	\$.24
1	R4	45 J 5078	0.62-ohm 2-watt wirewound resistor	\$.48
1	R5	45 J 6045	510K $\frac{1}{2}$ -watt composition resistor	\$.24

Table 7-1. Parts List For the Signal Tracer (Cont.)

Quantity	Symbol	Allied Catalog Number	Description	Price
1	R6	46 J 1110	1K wirewound potentiometer, Mallory VW-1K	\$ 1.38
1	S1	46 J 5359	SPST switch attached to potentiometer R1, IRC type 76	\$.75
1	S2	56 J 4080	SPST Phono-Radio switch Centralab 1460	\$ 1.08
1	SPKR	16 J 3500	2 1/2-inch square, 3.4-ohm speaker, Utah SP25A	\$ 2.25
1	T1	54 J 2365	Miniature transistor-type output transformer (pri. 100 ohms C.T., sec. 4, 8, 16 ohms). Knight 6T35 HF	\$ 4.16
1		21 J 4153	Direct probe kit, EICO PDK	\$ 2.95
1		21 J 4151	Demodulator probe kit, EICO PSDK	\$ 3.95
1		42 J 7624	7-inch X 5-inch X 3-inch Minibox Bud CU-2108-A	\$ 2.00
1		47 J 0919	Perforated phenolic board, Vector 64AA18	\$ 1.60
1		47 J 6087	12-contact IC socket, Augat 8058	\$ 9.70
21		47 J 0878	Push-in terminals, Vector T9.4	pkg of 5 \$ 1.38 per 100
2			5-40 round-head machine screws	
2			5-40 hexagonal nuts	
2		47 J 4140	Plastic pointer knobs	\$.15 ea.
1		18 J 5184	Battery plug, Cinch-Jones 5D	\$ 1.39
2		47 J 1958	Cable plugs, Amphenol 75-MC-1F	pkg of 2 \$.64 ea.
Misc.			Insulated stranded hookup wire	
			Bare tinned solid hookup wire	

USES

The instrument may be used in the regular manner for tracing signals in AF and RF circuits. The readings of the meter give comparative indications of signal strength. For high-amplitude input signals, the sensitivity of the tracer is easily reduced by turning down the gain control.

CHAPTER 8

ELECTRONIC DC VOLTMETER

The superiority of the vacuum-tube voltmeter (VTVM) and of its descendent the transistor voltmeter (TVM) rests on the near-zero loading of a circuit under test by these electronic-type meters and on their stability. Because the transistor meter has a self-contained battery power supply, it has offered

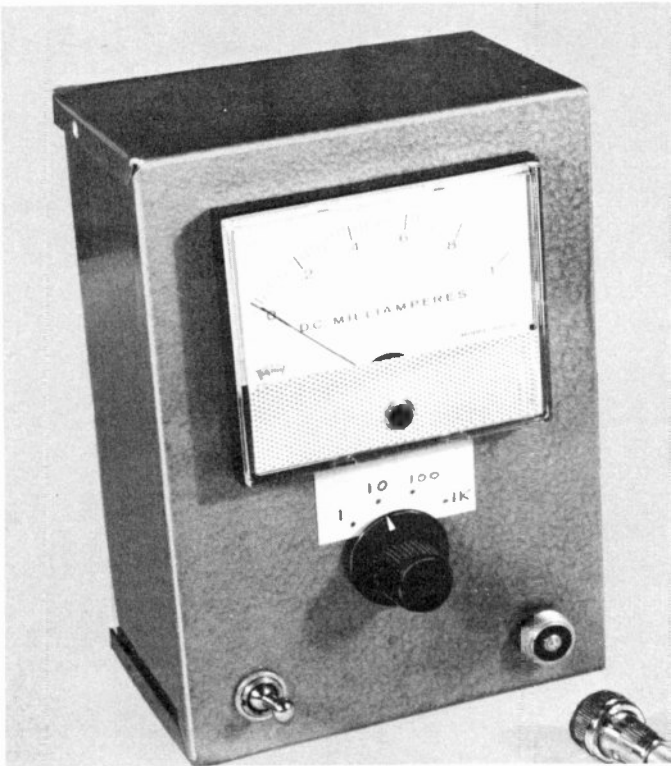

Fig. 8-1. Overall view of the electronic DC voltmeter.

the further advantages of freedom from the power line (and the trailing cord), elimination of hum interference from its own power supply, very light weight, and cool operation.

The best electronic DC voltmeters use a balanced circuit and several stages, and it is not easy for the amateur and hobbyist to design such an arrangement using direct-coupled stages. It is here that the IC comes to his aid, containing as it does the well-balanced stages in a symmetrical circuit. This chapter describes an electronic DC voltmeter employing one IC. It has an input resistance of 200,000 ohms per volt and is very stable. Unlike the VTVM, it requires no zero adjustment.

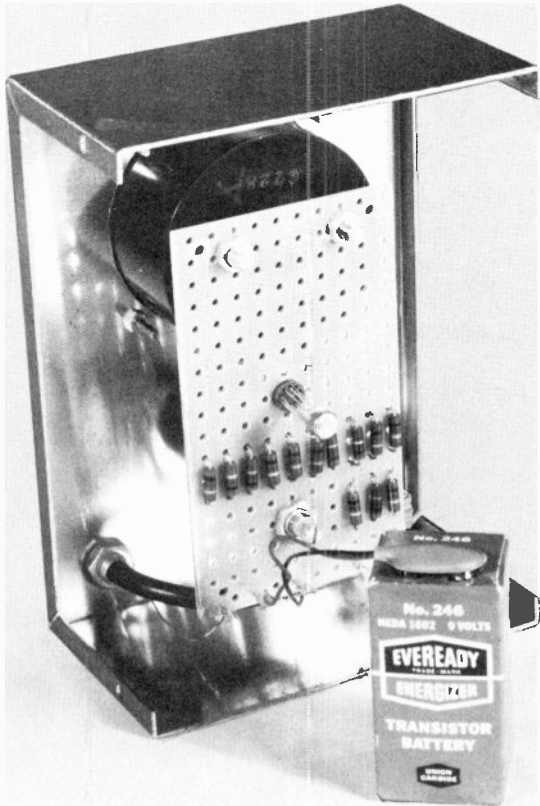
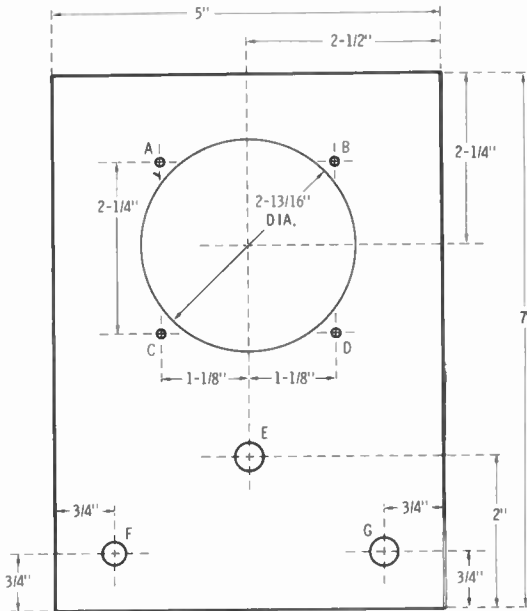

Fig. 8-2. Inside view of the electronic voltmeter.

This instrument has four ranges: 0-1, 0-10, 0-100, and 0-1000 volts DC, all of which may be read on the 0- to 1-milliampere scale of the meter by mentally placing the decimal point. The input resistance of 200,000 ohms per volt means that the instrument resistance is 0.2 megohm on the 1-volt range, 2 megohms on the 10-volt range, 20 megohms on the 100-volt range and 200 megohms on the 1000-volt range.

Fig. 8-1 gives an outside view of the completed voltmeter, with the probe unplugged. Fig. 8-2 shows the inside of the instrument, with the self-contained 9-volt battery. For constructional guidance, Fig. 8-3 shows the front-panel drilling scheme; Fig. 8-4, the circuit diagram; Figs. 8-5A and 8-5B, layout and wiring of components on the circuit board; and Fig. 8-6, the layout of components on the back side of the front panel. For aid in understanding the circuit, the internal circuit of the Motorola HEP-556 integrated circuit used is shown in Fig. 8-7.



HOLES A, B, C, D, : 1/8" DRILL. HOLES E, G, : 3/8" DRILL. HOLE F: 5/16" DRILL.

Fig. 8-3. Front-panel drilling plan for the electronic voltmeter.

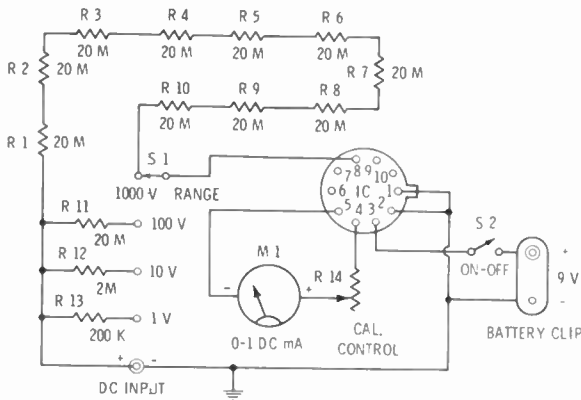
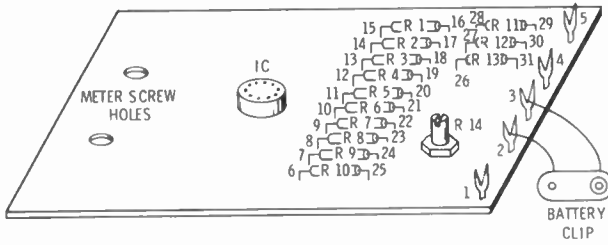

Fig. 8-4. Circuit of the electronic voltmeter.

This instrument is built in a 7-inch x 5-inch x 3-inch gray hammertone aluminum case (Bud CU-2108-A *Minibox*, Allied No. 42 J 7624). The meter is 3½-inch rectangular 0-1 DC milliammeter (Triplett 320-G, Allied No. 55 J 6635); the instrument is given added ruggedness by this meter, which takes the place of a more delicate microammeter. The circuit is wired on a 2¾-inch x 4¾-inch perforated board which is supported by the two ¼-inch terminal screws on the back of the meter (Fig. 8-2). All components are on this board, except range switch S1, ON-OFF switch S2, and input jack J1, which are mounted on the front panel.

This circuit is that of a symmetrical, direct-coupled DC amplifier with milliammeter readout. Reference to the internal circuit of the IC (Fig. 8-7) shows how the Motorola HEP-556 IC is used for this purpose. Note that input transistor Q3 directly drives output transistor Q5, and that input transistor Q4 directly drives output transistor Q6. The Q3 and Q4 stages are voltage amplifiers, and the Q5 and Q6 stages are low-impedance-output emitter followers. Q3 and Q4 also have a common-emitter resistor (R3). Transistors Q1 and Q2 may be ignored. With this symmetrical arrangement, an input signal may be applied (with opposite polarity) to input terminals 1 and 8, and the corresponding output signal taken from terminals 4 and 5. In the electronic voltmeter, one input terminal



(A) Above-board layout.

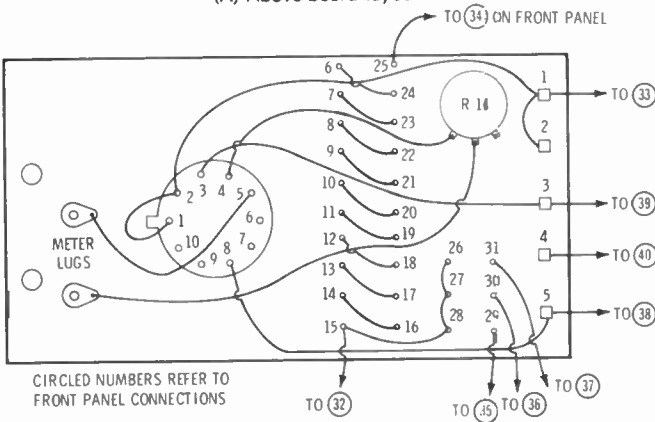

(B) Below-board wiring.

Fig. 8-5. Layout and wiring of the electronic voltmeter.

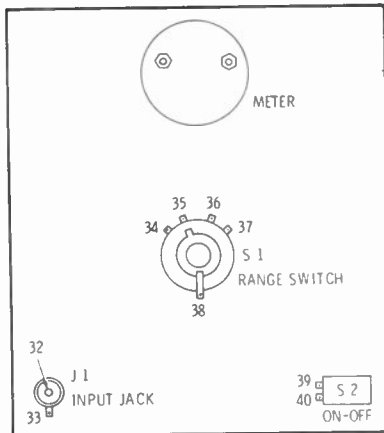

Fig. 8-6. Layout and terminals of front-panel components.

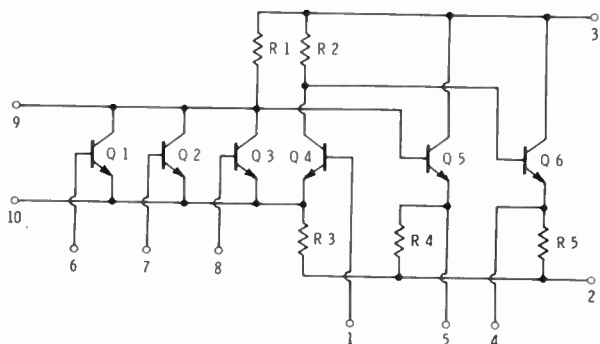

Fig. 8-7. Circuit of the Motorola HEP-556 IC used in the voltmeter.

(No. 1) is grounded, just as one of the input grids is grounded in the VTVM, and the input signal is applied to the other input terminal (No. 8). Also the milliammeter is connected between the two output transistors (that is, to terminals 4 and 5) just as the microammeter is connected between the output plates or cathodes in the VTVM. If you have difficulty relating Fig. 8-7 to the full circuit in Fig. 8-4, turn back to Fig. 1-9, where the external connections are shown made to the full circuit of the HEP-556 and are discussed in the accompanying text.

Aside from the milliammeter, input jack, and ON-OFF switch (Fig. 8-4), the only outboard components required are a voltage-range selector and calibration-control rheostat R14. The voltage-range selector is comprised of a single-pole, 4-position, nonshorting, rotary selector switch, S1, (Centralab 3215J, Allied No. 56 J 4350) and associated resistors R1 to R13. The 200-megohm resistor required for the 1000-volt range is made by series-connecting ten 20-megohm resistors (R1 to R10). The CALIBRATION CONTROL (R14) is a 1000-ohm wirewound rheostat (Mallory VW-1K, Allied No. 46 J 1110). Since this unit needs no readjustment between occasional calibrations, it is provided with a slotted shaft for screwdriver adjustment and is mounted on the circuit board where, inside the instrument case, it will be protected from tampering. Unlike the VTVM and TVM, this circuit is so well balanced, due to the superb matching of internal components of the IC, that no zero adjuster is required.

Since the instrument draws less than 10 mA, use of a transistor-type battery is entirely feasible. The one seen in Fig. 8-2 is a 9-volt Eveready No. 246 (Allied No. 18 J 5154).

The input jack (J1) is a concentric chassis receptacle (Amphenol 75-PC-1, Allied No. 47 J 1965). This jack accepts a matching plug (Amphenol 75-MC-1F, Allied No. 47 J 1958). The DC voltage under measurement is applied at this jack from a shielded test probe. For this purpose, a direct-input probe (EICO PDK, Allied No. 21 J 4153) is used. This probe and its cable is in kit form, and during its assembly must have the Amphenol plug, mentioned above, attached to its cable. The cable and plug are visible in Fig. 8-1.

IC EMPLOYED

The internal circuit of the Motorola HEP-556 integrated circuit used in this instrument is shown in Fig. 8-7. While this is a digital IC (a three-input gate), it lends itself well to this linear application. Operation of the IC has already been described. Here, we only need to repeat that transistors Q1 and Q2 are unused and may be ignored along with their terminals: 6, 7, 9, and 10.

The HEP-556 is housed in a 10-terminal TO-5 can. In this IC, terminal No. 1 is at the key tab of the can, as may be seen in Fig. 8-4.

CONSTRUCTION

The main circuit is assembled on a $2\frac{3}{4}$ -inch x $4\frac{3}{4}$ -inch piece of perforated phenolic board (Allied No. 47 J 0919). Figs. 8-2, 8-5A, and 8-5B show layout of components on this board. All resistors are on this board and are mounted without standoff terminals; their leads are simply passed through holes in the board (Figs. 8-5A and 8-5B) and connected, as required, under the board. Vector T9.4 push-in terminals are provided above the board for external connections and are labelled 1 to 5 in Fig. 8-5B. For this purpose, mount the terminals with their broad jaws above, and narrow jaws below the board. Rheostat R14 also is mounted on the board. This unit

and the IC socket (Cinch-Jones 10-ICS, Allied No. 47 J 0195) are mounted in $\frac{3}{8}$ -inch diameter holes drilled in the board. The socket hole must be notched, as shown in Fig. 2-3, Chapter 2.

All resistors in the voltage-range string (R1 to R13) must be selected as close as possible to rated resistance. Actually, they may be off value, as long as all of them are off by the same amount and in the same direction. In some instances, it may be necessary to connect two or more resistors in series to obtain desired values.

Follow this procedure:

1. Read "Construction Hints" at the end of Chapter 2.
2. Drill the front panel of the *Minibox*, using the plan given in Fig. 8-3.
3. Mount the input jack (J1), range switch S1, and ON-OFF switch S2 on the front panel.
4. Assemble the test probe, attaching the concentric plug to the end of its cable.
5. Cut a $2\frac{3}{4}$ -inch x $4\frac{3}{4}$ -inch piece of perforated board.
6. Drill the $\frac{3}{8}$ -inch diameter holes for the socket and rheostat. It is best to drill the socket hole slightly undersize and then to ream it out carefully until a tight fit is obtained for the socket. If the directions given in Fig. 2-3, Chapter 2, are followed, the socket may be tightly locked by rotating it after insertion into the notched hole.
7. Drill two $\frac{1}{4}$ -inch clearance holes ($1\frac{1}{4}$ inches apart) near the top edge of the board (Figs. 8-5A and 8-5B) to accommodate the meter terminal screws.
8. Mount the socket and rheostat.
9. Press push-in terminals (labeled 1 to 5 in Fig. 8-5B) into holes in the board, for the external connections indicated.
10. Mount the resistors by passing their pigtailed through the nearest holes, as shown in Fig. 8-5A, and connect and solder their pigtailed under the board, as shown in Fig. 8-5B.
11. Solder insulated leads to the various circuit points shown in Fig. 8-5B. These leads will run to front-panel components. Note that the bottom view of the socket is given.
12. Completely wire the underside of the board in the manner

shown in Fig. 8-5B, using the minimum amount of solder. For this wiring, use a thin, insulated, stranded hookup wire; thicker wire is too large for the closely-spaced IC socket terminals. For portions of the wiring that require no insulation (such as jumpers between socket terminals, and the common ground bus), use solid, tinned, No. 22 wire. Wire the battery clip to terminals 2 and 3 above the board as shown in Fig. 8-5A.

13. Complete the wiring by connecting the leads from the circuit board to the front-panel components. Follow the number coding shown in Fig. 8-5A, 8-5B, and 8-6. Run a short length of shielded cable from the high terminal of input jack J1 to terminal 5 on the circuit board (a portion of this lead may be seen at lower left in Fig. 8-2).
14. After the wiring has been double-checked, carefully insert the IC into the socket. Note that terminal 1 is at the key tab of the IC can.
15. Attach the lug-terminated leads to the meter screw terminals as shown in Fig. 8-5B.
16. Mount the circuit board on the back of the meter by slipping the clearance holes over the meter-terminal screws. Tighten the meter nuts to secure the board.

TESTING

Test the voltmeter only after all wiring has been verified as correct.

1. Throw switch S2 to its OFF position.
2. Set rheostat R14 to its maximum-resistance position.
3. Set switch S1 to its 10-volt position.
4. Connect the probe to input jack J1.
5. Connect an accurately known 10-volt DC source to the probe.
6. Clip in the battery.
7. Throw switch S2 to its ON position, noting that meter M1 is deflected.
8. Carefully advance rheostat R14 to bring the meter reading to exact full scale.

9. Throw switch S1 to its 100-volt position and note the new reading of the meter.

Table 8-1. Parts List for the Electronic Voltmeter

Quantity	Symbol	Allied Catalog Number	Description	Price
1	B	18 J 5154	9-volt transistor-type battery, Eveready No. 246	\$ 1.30
1	IC	50 J 26 HEP-556	Integrated circuit	\$ 2.99
1	J1	47 J 1965 and 47 J 1958	Concentric chassis receptacle (Amphenol 75-PC-1M) and matching cable plug (Amphenol 75-MC-1F)	\$.41 \$.64
1	M1	55 J 6635	0-1 DC milliammeter, Triplett 320-G	\$17.50
10	R1 to R10	45 J 5005 C	20-megohm 1/2-watt composition resistors, RC20, 5%	\$.08 ea.
1	R11	45 J 5025 C	20-megohm 1-watt composition resistor	\$.12
1	R12	45 J 5025 C	2-megohm 1-watt composition resistor	\$.12
1	R13	45 J 5025 C	200K 1-watt composition resistor	\$.12
1	R14	46 J 1110	1000-ohm wirewound potentiometer, Mallory VW-1K	\$ 1.38
1	S1	56 J 4350	Nonshorting rotary selector switch, Centralab 3215J	\$ 1.02
1	S2	56 J 4100	SPST toggle switch	\$.62
1		26 J 4153	Direct probe kit, EICO PDK	\$ 2.95
1		42 J 7624	7-inch X 5-inch X 3-inch Minibox, Bud CU-2108-A	\$ 2.00
1		47 J 0919	Perforated phenolic board, Vector 64AA18	\$ 1.60
1		47 J 0195	10-contact IC socket, Cinch-Jones 10-ICS	\$.72
5		47 J 0878	Push-in terminals, Vector T9.4	\$ 1.38 per 100
1		18 J 5184	Battery plug, Cinch-Jones 5D	\$ 1.39 pkg of 2
1		47 J 4113	Pointer-type knob, Raytheon DS90-3-2	\$ 1.05
Misc			Small insulated stranded hookup wire Bare tinned solid hookup wire	

USES

The favorable input sensitivity of 200,000 ohms per volt suits this instrument for use in many forms of testing which

demand the simplicity of a simple VOM but require the virtually zero loading afforded by an electronic voltmeter. A standard RF probe (available factory-built or in kit form) will convert the meter for direct readings of peak-to-peak AC voltage.

INDEX

- A**
- AF/RF signal tracer, 72-82
circuit, 75
description, 73-78
front-panel drilling plan, 74
IC employed, 78
inside view, 73
layout and wiring, 76
parts list, 81-82
testing, 80
uses, 82
- Audio amplifier, quarter-watt, 56-63
- Audio amplifier, 40-47
circuit, 42
description, 42-43
IC employed, 43-44
parts list, 47
testing, 46
- B**
- Bias current, input, 35
- C**
- Ceramic-to-metal flat package, 23
- Chip, 12, 15
- Concept of the module, 7-9
- Construction hints, 38-39
- Crystal oscillator, frequency-standard, 64-71
- Current sink, 17
- D**
- DC voltmeter, electronic, 83-93
- Device gain, 35-36
- Distortion, harmonic, 37
- Dual in-line package, 24
- E**
- Eight-lead package, 19
- Electrical ratings of IC's, 34-38
- Electronic DC voltmeter, 83-93
circuit, 86
description, 85-89
front-panel drilling plan, 85
IC employed, 89
inside view, 84
layout and wiring, 87
- layout and terminals, front panel, 87
parts list, 92
testing, 91-92
uses, 92-93
- F**
- Fourteen-lead package
ceramic-to-metal, 23
dual in-line, 24
- Frequency range, 36-37
- Frequency-standard crystal oscillator, 64-71
circuit, 66
description, 65-67
IC employed, 67-68
layout and wiring, 65
output waveform, 66
parts list, 70
testing, 70-71
uses, 71
- G**
- Gain
common-mode voltage, 35
differential voltage, 36
single-ended voltage, 35
- H**
- Harmonic distortion, 37
- HEP-556 as DC voltmeter, 18
- High-gain preamplifier, 48-55
circuit, 50
description, 49-50
IC employed, 51-52
Layout and wiring, 49
parts list, 54
testing, 53-54
uses, 55
- Hybrid IC, 20
- I**
- IC
as super module, 9-12
background, 7-12
chip, 12, 15
electrical ratings, 34-38
hybrid, 20
in circuit diagrams, 26-29

- installation, 27-31
 linear, 20, 22
 manufacture, 12-16
 mechanical specifications, 25
 mounting clips, 31-32
 packages, 10-12
 planar, 19
 sockets, 29-31
 soldering, 30, 32-33
 thin-film, 20
 unused terminals, 33
 versus wired board, 13
- Impedance**
 input and output, 35
 Input bias current, 35
 Input impedance, 35
 Input voltage, maximum, 37
- L**
- Linear IC, 20, 22
- M**
- Maximum input voltage, 37
 Mechanical specifications, 25
 Microcircuits, 9
 Microelectronics, 9-10
 Module
 advantages, 9
 concept, 7-9
 types, 9
 versus IC, 8
 Mounting clips, 31-32
- N**
- Nature of IC's, 12-17
 Noise figure, 37
- O**
- Operating temperature, maximum, 37
 Operating temperature range, 37-38
 Oscillator, crystal, 64-71
 Outboard components, 25, 27
 Outlines and dimensions, 25
 Output impedance, 35
 Output voltage, maximum, 37
- P**
- Planar IC, 19
 Power dissipation, 34
- Pre-amplifier
 audio, 40-47
 high-gain, 48-55
- Q**
- Quarter-watt audio amplifier,
 56-63
 circuit, 58
 description, 57-59
 IC employed, 59-60
 layout and wiring, 57
 parts list, 62
 testing, 61
 uses, 63
- S**
- Screw terminals, 32
 Signal tracer, AF/RF, 72-82
 Sockets,
 IC, 29-31
 Soldering IC's, 30, 32-33
 Stability
 of operation, 16-17
 temperature, 17
 Supply current, 34
 Supply voltage, 34
- T**
- Temperature range, operating, 37-38
 Temperature stability, 17
 Ten formed-lead package, 21
 Ten-lead package, 20
 Thin-film IC, 20
 TO-5
 8-lead package, 19
 10-formed-lead package, 21
 10-lead package, 20
 12-lead package, 22
 Triangular symbol, 28
 Twelve-lead package, 22
 Types of IC's, 19-23
- U**
- Useful frequency range, 36-37
 Use of IC's-general method, 33
- V**
- Voltmeter, DC, 83-93

THE ALLIED ELECTRONICS LIBRARY

ELECTRONICS DATA HANDBOOK



Contains math constants and algebraic formulas; log and trig tables; tables of roots, powers and reciprocals; formulas for Ohm's law, resistance, capacitance, inductance, impedance, vacuum tubes, transistors, etc. color codes; interchangeable tubes; lamp data; wire table; metric relationship; decibel tables attenuator networks. 112 pages, 6x9".

23 J 7398 EP. Postpaid in U.S.A. \$1.00

USING YOUR TAPE RECORDER



ABC's of modern tape recording. Written in simple language for the hobbyist and nonprofessional user. Chapter headings: Sound—What Is It; Your Recorder; Microphone Recording; Recording "Off the Air"; Dubbing from Records and Tape; Editing Tape; Sound and Special Effects; Sound for Slides and Home Movies; Recorder Maintenance. 96 pages, 5 1/4 x 8 1/4".

23 J 7730 EP. Postpaid in U.S.A. 50c

UNDERSTANDING SCHEMATIC DIAGRAMS



A basic text which is a must for the understanding of the science of electronics. Explains the functions of components, their use in electronics circuits, the symbols and techniques of schematic diagrams. Chapters: Getting Started; Fundamental Components; Tubes and Semiconductors; Other Components; Connecting Devices; Putting It All Together. Illustrations, diagrams, and symbols. 112 pages, 5 1/4 x 8 1/4".

23 J 7931 EP. Postpaid in U.S.A. 75c

GETTING STARTED IN ELECTRONICS



Covers types of transmission—AM, FM, TV, CW, and short wave. Explains uses of basic components, electron theory, resistance, magnetism, capacitance, antennas, and test equipment. Building projects: crystal set, walkie-talkie, 1-tube set, transistor set, intercom, burglar alarm, light detector, code-practice oscillator, and 5-band short wave receiver. 112 pages, 5 1/4 x 8 1/4".

23 J 7705 EP. Postpaid in U.S.A. 50c

HOW TO BUILD ELECTRONIC KITS



Discusses types of kits available; how to select kits, tools required. Chapters: The Values of Kit Building; How To Identify Parts and Components; Connecting Components; Electrical wiring; Soldering. Includes details on building 3 popular kits. 96 pages, 5 1/4 x 8 1/4".

23 J 7066 EP. Postpaid in U.S.A. 50c

ALL ABOUT HI-FI-AND STEREO



Helps you understand, select, and enjoy your music system. Covers components used; program sources—records, tape, broadcasts; discusses tape recorders, kits, use of transistors, and includes data on planning a built-in system. Glossary, charts, and illustrations. 96 pages, 5 1/4 x 8 1/4".

23 J 7699 EP. Postpaid in U.S.A. 50c

BEST WAYS TO USE YOUR VOM AND VTVM



Covers construction and use of VOM and VTVM. Tells how to test capacitors, chokes, switches, and other components. Covers functions of shunts and multipliers and explains calculations necessary for obtaining correct shunt and multiplier values. Discusses use in CB, ham radio, and hi-fi. 112 pages, 5 1/4 x 8 1/4".

23 J 7067 EP. Postpaid in U.S.A. 50c

ENCYCLOPEDIA OF ELECTRONICS COMPONENTS

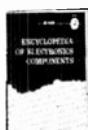

Alphabetical listing of the basic electronics components with a clear description and illustration of each. Prepared for the newcomer, hobbyist, and experimenter; this is really an "instant" course in electronics. Edited by A. C. Todd, Ph.D., Professor of E.E. Illinois Institute of Technology. 112 pages, 5 1/4 x 8 1/4".

23 J 7930 EP. Postpaid in U.S.A. \$1.00

UNDERSTANDING AND USING YOUR OSCILLOSCOPE



Edited by William A. Stocklin, Editor, Electronics World. Chapters: History of the Cathode-Ray Tube; Basic Oscilloscope Principles; Interesting Applications for an Oscilloscope; Oscilloscope Tests and Measurements; Types of Scopes Needed for Various Applications; Auxiliary Equipment; Oscilloscope and Test Equipment Kits. 128 pages, 5 1/4 x 8 1/4".

23 J 7932 EP. Postpaid in U.S.A. 75c

UNDERSTANDING AND USING CITIZENS BAND RADIO



Chapter headings: Getting Acquainted With CB Radio; Obtaining the License; About the Equipment; Setting Up A Station (Mobile and Base Station Installations); CB Antennas; Operating CB Equipment; The Uses and Abuses of CB Radio. Discusses CB servicing. Covers operating procedure and using the "10" signals. 112 pages, 5 1/4 x 8 1/4".

23 J 7701 EP. Postpaid in U.S.A. 50c

UNDERSTANDING TRANSISTORS AND TRANSISTOR PROJECTS



Covers basic transistor applications, characteristics, and construction. Discusses NPN, PNP, alloy-junction, drift, tetrode, surface barrier, power types, etc. Transistor projects: audio amplifier, 1-transistor radio, capacity-operated relay, code-practice oscillator, wireless broadcaster, timer, electronic flasher, and photoelectric controller. 112 pages, 5 1/4 x 8 1/4".

23 J 7602 EP. Postpaid in U.S.A. 75c

INTEGRATED CIRCUITS FUNDAMENTALS & PROJECTS



By Rufus P. Turner, Ph.D. Development, design, applications and electrical features of IC's are covered in non-technical language. Provides details on use of IC's in easily-built, projects including a simple audio preamplifier, high gain preamplifier, quarter-watt audio amplifier, crystal oscillator/frequency standard, AF/RF signal tracer and DC voltmeter. 96 pages, 5 1/2 x 8 1/2".

23 J 7625 EP. Postpaid in U.S.A. 75c

DICTIONARY OF ELECTRONIC TERMS



New eighth edition. Over 4,800 terms. Edited by Robert E. Beam, Ph.D., Professor of Electrical Engineering, Northwestern University. Covers radio, monochrome and color TV, high fidelity, recording, Radio Amateur, Citizens Band, Public Address and solid-state and integrated circuit technology. Includes aerospace, math, physics and computer terms. 112 pages, 6x9".

23 J 7756 EP. Postpaid in U.S.A. \$1.00



published by

ALLIED RADIO CORPORATION

CHICAGO, ILLINOIS 60680

23 7625

