

6P11
TANDY

**Practical
Transistor
Novelty
Circuits**

by
H. Ness

NO. 62-9005

40p

**PRACTICAL
TRANSISTOR
NOVELTY
CIRCUITS**

■
by

H. NESS



TANDY CORPORATION

© 1972

First Published June 1972
Reprinted, August 72
Reprinted, February 73
Reprinted, October 73
Reprinted August, 1974

Although every care is taken with the preparation of this book the publishers will not be responsible for any errors that might occur.

I.S.B.N. 0 85934 010 4

Printed in Great Britain by C. Nicholls & Company Ltd.

CONTENTS

Introduction	5
Electronic Thermometer	7
Radioactivity Detector	10
Ligh Flasher	14
Gram to Radio Converter	16
Intercom	18
Sound Triggered Flash	21
Electronic Organ	23
Metal Locator	26
Insect Repellant	30
The Fastest Draw Game	32
Noise Limiter	35
Burp Box	37
Audio Fliter	40
Rain/Water Alarm	43
Magic Candle	46
Tooter	48
Super High Insulation Tester	50
Lie Detector	53
Temperature Alarm	55
Electronic Doorbell	57
Electronic Siren	59
Simple Amplifier	61
Veroboard Dimensions	63

TO HELP OUR EUROPEAN AND AMERICAN READERS
 WE INCLUDE HEREWITH A FULL EQUIVALENTS AND
 INTERCHANGEABILITY LIST OF THE SOLID STATE
 DEVICES USED IN THE CIRCUITS SHOWN IN THIS BOOK.

TANDY-ARCHER-RADIO SHACK
 TYPE NUMBER

2N2926	RS276-2013
BY100	RS276-1106
2N4702	RS276-2021
AD192	RS276-2006
BC109	RS276-2009
AC128	RS276-2004 / 5
2N2646	RS276-2029
2N2926G	RS276-2013
CR91	RS276-1102
CRS1 05	RS276-1059
QC71	RS276-2004
1N914	RS276-1102
2N4202	RS276-2013

NOVELTY TRANSISTOR CIRCUITS - INTRODUCTION

The circuits in this book do not fall into the more common electronics categories such as radio, audio or test gear and these types of circuit have often been ignored for this reason.

Many of the circuits are thoroughly practical and can be built as permanent projects while others are included more for fun or interest. Even though you may not want to build a particular circuit it is useful to understand the circuit and to see the techniques used. Apart from the actual circuits, a wide variety of techniques are used and in places these are described in some detail so that a particular part of the circuit can be used elsewhere. The Radioactivity Detector is one such example; while the basic project may have only limited appeal, the technique for obtaining a high voltage from a small battery may be of interest.

This book is intended primarily for the intelligent constructor - the ability to read a circuit is assumed as is the ability to convert this into a layout. Some general points on construction are given but this part of the operation is left largely up to the reader. Many of the circuits leave room for further experimenting and many notes are included to start the reader off.

All the circuits have been thoroughly tested and constructing them should not be difficult. The simplicity of the circuits make the possibility of mistakes unlikely but if a circuit fails to work always suspect your wiring or layout before doubting the components. Finding out why a circuit does not work is a special skill and one that is only gained with experience. However, there is one golden rule that should be followed - approach the problem in a logical manner; isolate the section that does not seem to be operating and only then do the tests to find out what is amiss.

COMPONENTS

All the components specified should be readily available from most components shops. In the case of specialised components such as the relays, the geiger tube or the special resistors in the Electronic Organ, components may have to be bought from one of the larger mail order component suppliers. All of these produce catalogues and the components used here are all listed.

A variety of different transistor types are used but all these are cheap and widely available. Many of these transistors have equivalents; that is similar types but with a different coding. Many of these can be identified from the Babani Transistor Equivalents and Substitutes handbook.

Some transistors are sold by gain grouping such as the 2N2926. There is often a colour blob on these and there is an additional letter at the end of the number such as O, Y or G. The G, for green, is the highest gain group and should be used where possible but the other groups will do.

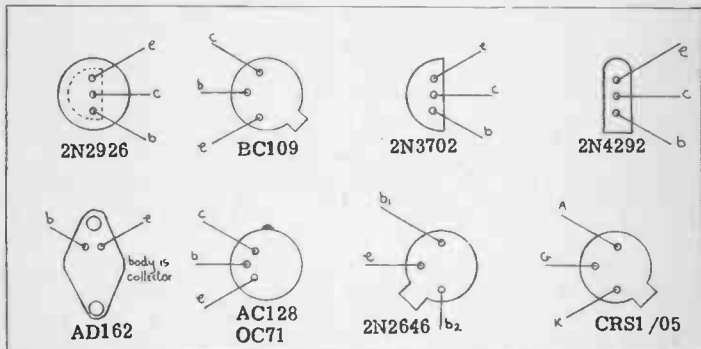

Base connections of the transistors used in this book are all viewed from the lead ends.

All resistors can be 10 per cent, $\frac{1}{4}W$ types except where stated. The tolerance of the capacitors used is, similarly, not critical, where no particular type is mentioned any sort, ceramic, polystyrene etc., can be used. The working voltage of the capacitors should be at least as high as that shown in the components list, usually 12V, but it can be as high as you like. In all cases the actual value of the electrolytics is very uncritical and a factor of two to one will make no appreciable difference.

It is not possible to give an indication of the cost for building up each circuit as prices vary considerably from supplier to supplier and prices change each month. Fortunately, there has been a definite tendency for component prices to fall in recent years and none of the components except for the meters, the geiger tube (and possibly the speakers) should cost more than £1.00.

All the prototypes were built up on VEROBOARD. For those unfamiliar with this product it is a method of building up circuits on a general purpose printed circuit board. It is easy to work out a layout and the final result will look very neat. The only exception is the Super High Insulation Tester and the text will explain the reason.

ELECTRONIC THERMOMETER

All semiconductor materials are heat sensitive, some more so than others. Usually this is a disadvantage and many components in circuits - especially those using germanium devices - are included to overcome the effect on operation of heat.

There is however at least one semiconductor device which is designed specifically to take advantage of this property - the thermistor, which is a resistor whose ohmic value varies with its temperature. Thermistors can have either a positive or negative temperature coefficient but most of those in common supply have a negative coefficient - that is their resistance falls with an increase in temperature. The resistance/temperature curve for most thermistors is reasonably linear and it will be seen that quite a simple circuit can be made to take the place of a conventional mercury or spirit thermometer.

It is necessary to ensure that the applied voltage is absolutely constant, far more so than a plain battery would be and so a Zener diode is used in the supply circuit. A Zener diode, if operated within its correct ratings will assure that whatever the condition of the power supply, there will always be exactly the same voltage across it (assuming that the supply voltage exceeds the operating working voltage).

With SW1 in the position shown, off, the meter terminals are shorted and no battery is connected. It is always a good idea to short out the terminals of a meter when not in use as this damps the movement in the case of accidental knocking and since there are spare switch positions, this facility is included.

In position B the battery is applied to the circuit through the resistor R4 on the other side of which is the Zener. The meter M1 is connected in a bridge circuit with R1 and the thermistor in one leg and with VR1 across the supply in the other. At 25°C the thermistor has a nominal resistance of about 500 ohms so there is about one third of the Zener voltage on that side of the meter. If VR1 is set to a position so that the upper part of the track is twice that of the lower track there will be no voltage difference across the meter and so no current will flow. If however the thermistor is heated above the nominal 25°C, the voltage on that side of the meter will fall and the meter will show a reading which will be directly proportional to the voltage which in turn is directly proportional to the temperature. By altering the setting of VR1 the meter can be made to read any range of temperature that is required. It is a fairly simple matter to calibrate the scale. For instance, if it is required to measure weather temperatures we could say that the mean temperature is perhaps 15°C (60°F) and we could make this the centre scale. It will be necessary to mix hot and cold water until this temperature is

reached (this can be tested using a mercury thermometer). The body of the thermistor is then put under water whilst making sure that the water does not come into contact with the wire leads. The construction of the device specified makes this a fairly easy task. When the thermistor has reached a stable resistance, VR1 is set so that the meter reads centre scale deflection. This control should not be touched again. To calibrate the scale it should then be a matter of adding hot water until the meter reaches full scale deflection and noting what this temperature is with the mercury thermometer. The lower end of the scale can then be calibrated but this is not really necessary as the deflection is constant. However many degrees full scale is over 15°C will indicate how many degrees zero deflection is below that temperature. On the prototype with a 15°C centre scale, the upper limit was 40°C (105°F) and the lower limit was -10°C (15°F) - quite a range. For calibrating at 100°C it is not necessary to put the thermistor into boiling water; it is quite sufficient to hold the thermistor in a jet of steam from a kettle. For low temperatures, 0°C can be obtained by putting the thermistor into a bowl of melting ice.

The third position of the switch is for testing the battery voltage. The Zener is bypassed and the battery is applied directly across meter with two accurate (at least 5%) resistors in series. It is necessary to use two resistors to obtain the correct value. If the meter reads over half scale deflection, the battery is O.K.; if not it should be replaced. The battery will last a considerable time as current is only drawn while the unit is actually on. Readings are shown instantly on switch on; there is no settling down time. The thermistor can be mounted anywhere in the circuit as the air temperature inside any cabinet will not be much different from that outside. Alternatively the thermistor could be mounted outside a house with the meter inside, thus enabling the outside temperature to be seen at a glance. The resistance of even quite a long length of wire will make no difference to the readings.

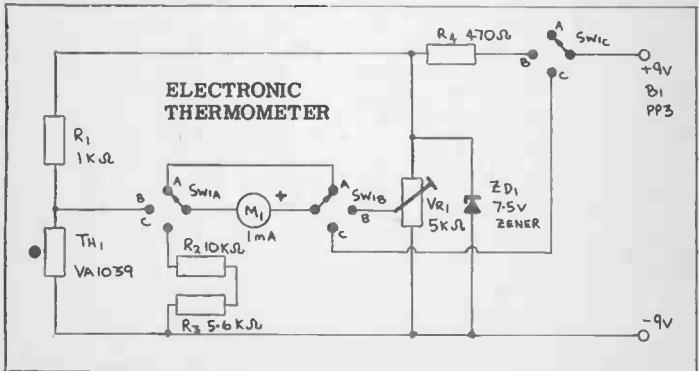

Components List

R1 1K ohms
R2 10K ohms 5%
R3 5.6K ohms 5%
R4 470 ohms
VR1 5K linear pot.preset.

TH1 VA1039 Thermistor

ZD1 7.5V Zener diode 500mW or better
SW1 3-pole 3-way rotary switch.
B1 9V PP3 battery

RADIOACTIVITY DETECTOR

The term "Geiger Counter" refers to a device which actually counts the number of radio active particles passing through a specified area and while this circuit does not actually count, it does produce the familiar "click-click" which most of us associate with a geiger counter. Simple and inexpensive though the circuit is, it is just as accurate and as sensitive as any commercial device and whilst we hope that no one ever has reason to use the device seriously it does open a whole field of experimenting. The circuit is battery operated and so the device can easily be made portable.

The operational part of the circuit is the geiger tube. These are available on the surplus market and cost about £1.50 each. They require a high voltage supply but the current consumption is minute and so a very simple type of power supply is needed.

The operation of a geiger tube is as follows. When the correct voltage is applied between the anode and cathode of the tube in normal circumstances no current will pass. When however a radio active particle passes through the tube, a gas inside the tube is ionized and creates a momentary conduction of current between the two. Radioactive particles are emitted by any radioactive material and are very, very small physically. Three types of rays are emitted by any source but it is only the dangerous (in large quantities) gamma rays that are of interest. They travel at very high speeds and have tremendous penetration powers: only thick lead screens are effective unless great thicknesses of other materials are used. These gamma rays have no difficulty in penetrating the surround of the geiger tube.

However it is not simply a matter of applying any voltage across the tube. Below a critical voltage there is insufficient potential for the conduction to take place and above a certain voltage it will take place continuously once a particle has created a path. The voltage between these two is known as the "plateau" voltage and it varies with the individual tube though it is generally about 400V. As long as the voltage applied to the tube lies in this plateau region the tube will operate successfully.

The output is taken from across a high value load resistor, R2. The value of this resistor limits the current flow through the tube to a low level. The clicks produced by the radioactive rays can be heard in a crystal earpiece connected via a d. c. blocking capacitor across the load resistor. If desired this output could be taken to an amplifier feeding a loudspeaker but the source impedance of the amplifier should not be much below 1M ohms.

The high voltage supply comprises Tr1 and the associated components. The transformer T1 is a low current 250V primary, 9-0-9V secondary but here we are using it in reverse; the secondary is connected into a Hartley oscillator circuit with Tr1. C2 provides the feedback to the base to sustain oscillation and C3 tunes the transformer winding. The frequency of operation is far from critical and it does not have to be the 50Hz normally applied to such a component. The transformer used in the prototype with the component values shown worked at several hundred hertz. The base bias is provided by R1.

In order to control the voltage applied to the geiger tube, a variable resistor, VR1, is connected in the supply to the complete stage. At maximum resistance this reduces the voltage applied across the transistor and this in turn affects the voltage in what has become the secondary.

The varying current in the primary induces very high voltages in the secondary but even these are not sufficiently high to drive the tube and so a voltage doubler is included, this comprises D1, D2, C4 and C5. This arrangement doubles the voltage of the transformer and rectifies and smooths it. Note that there is high potential at this point, albeit at very high impedance. The voltage here is at so high an impedance that reliable readings are not possible with a multimeter, though an indication of several hundred volts will be given on meters with a sensitivity of 20,000 ohms per volt or better. Note that for this reason the components used for C4 and C5 (especially the latter) must be of high quality and have low leakage. Because the frequency of the oscillator is high and because so small a current is being taken, the value of the smoothing capacitor C5 is quite adequate although it is very low in comparison to conventional values.

There should be no problems in getting the circuit to operate once the high voltage supply is working.

The value of VR1 should be set so that each radio active particle produces a nice clean click, this level on the pot can be noted. Over a certain voltage all that is heard is a continuous "mush".

No special equipment is necessary to hear the device working. There is always a background level of radioactivity and for this type of tube there are on average 40 clicks per minute though these are about as random as you can get; there may be long intervals and then a whole series of clicks.

Several common place objects are radioactive. Luminous watch dials always used to be highly radioactive (and some still are) and some of the luminous paint used on ex-Government equipment is very high indeed, in fact it is well above the now accepted safety limits. The radioactive background level also varies considerably with geography. Around Aberdeen the level is very considerably higher than the average and this also applies to other areas built on granite. A number of everyday objects are also slightly radioactive including gas mantles and lighter flints.

At high levels the "clicks" will become far more frequent and in areas of high level the clicks will all blend together into a single sound though this is distinguishable from the mush produced by setting the voltage too high.

The current consumption is about 10mA. It is worthwhile avoiding touching the high voltage sections, for although it will only give a slight shock which is not dangerous, this is nevertheless unpleasant.

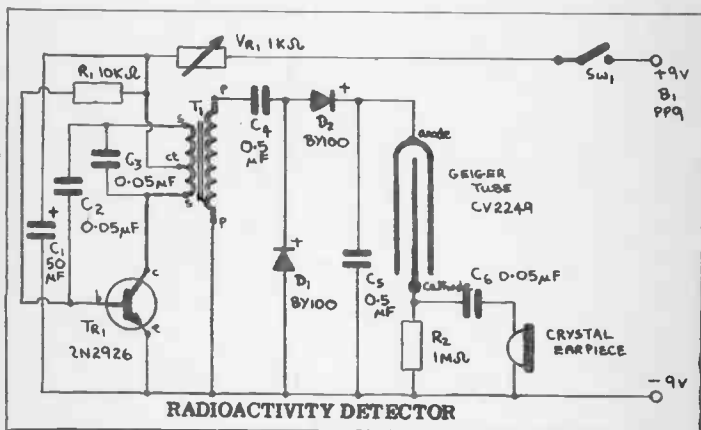

Components List

R1	10k ohms
R2	1M ohms
C1	50 μ F 12V
C2	0.05 μ F
C3	0.05 μ F
C4	0.5 μ F 600V
C5	0.5 μ F 600V
C6	0.05 μ F
Tr1	2N2926
D1	BY100
D2	BY100
VR1	1K ohms linear. pot
T1	250V primary, 9-0-9V secondary, lowest current available.
SW1	On/off switch (can be combined with VR1)
Geiger Tube	CV2249
B1	PP9, 9V
Crystal	Earpiece

LIGHT FLASHER

This circuit has a number of uses in many fields. It is common knowledge that flashing lights are far more noticeable than those that simply remain on. For example, advertising signs which come on and off are far easier seen than those that are simply lit up; police cars and ambulances also use flashing lights. In many cases, especially in motor cars, lights are used as warning devices, and it is not a difficult matter to convert these to flashing types rather than simply switch on. This makes them very much more apparent and while a straightforward light could be missed, a flashing light can not be.

The circuit is shown here for 9V but all that is necessary to convert it to the 12V used in cars is to use a 12V bulb, in fact the existing warning bulb can be used. The working tolerances of the components have been deliberately chosen to accommodate this higher working voltage. For use on 6V the circuit will also work and the specified bulb will suffice though it will not glow quite as brightly as it would do if it were connected directly to the supply. However this is made up for as the light is flashing and is therefore much more apparent.

The cost of the circuit is very small. When used in a car, no battery is needed, nor any switch and the bulb is already in place.

The circuit is a common multivibrator but unlike most designs the two transistors are not matched and there is an imbalance between the two sides. This is deliberate since only one of the transistors needs to carry high current, there seems little point in making both power types. The use of a true power transistor may at first seem wasteful but frequently such a circuit is working under very unfavourable conditions. In a car with the heater on, or on a very hot day, the temperature inside a car can reach high levels, quite outside the range expected of most circuits. If the circuit is to be used with a battery under normal conditions the AD162 may be replaced by another 2N3702 with no circuit changes being necessary. NPN transistors may also be used in the circuit but in this case the battery polarity will have to be reversed and the electrolytics (C1 and C2) will have to be wired in the other way around.

Although many people are familiar with the multivibrator, not many are quite sure how it operates.

When the supply voltage is applied, one transistor is bound to draw slightly more current than the other, this will be so even if great care is taken to ensure that the two sections are similar. Let's say that Tr2 draws more than Tr1 (though of course the same argument would apply if it was Tr2 that drew the higher current). This would cause a fall in the voltage at the collector of Tr2. This means that

C2 would start to charge and while it does so the potential at the base of Tr1 would not be enough to maintain conduction. However, as C2 continues to charge a certain point would be reached when Tr1 begins to conduct. This in turn causes a voltage drop at the base of Tr2, turning this off and so the cycle continues. When Tr2 is fully on, almost the complete supply voltage will appear across the bulb causing it to light up. Since it would be a waste of current to reduce the collector load of Tr1 to the low level of Tr2, balance is maintained in the circuit by having different values for C1 and C2. The flashing rate for the components shown is about one per second, but this can be altered by changing the value of R1. A lower value resistor here will increase the flashing rate, a higher value will slow the rate.

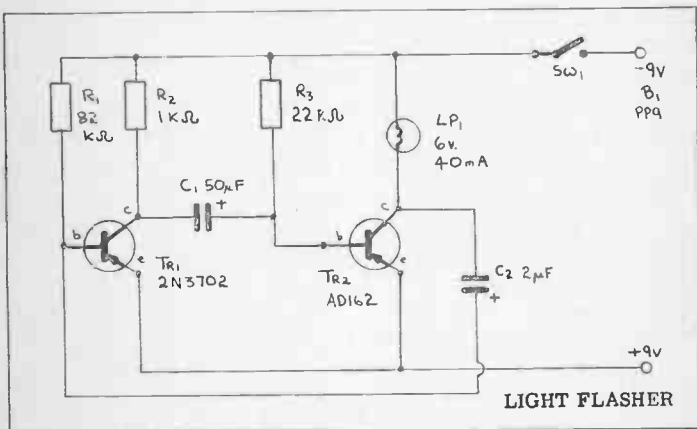

Components List

R1	82K ohms
R2	1K ohms
R3	22K ohms
C1	50 μ F 25V
C2	2 μ F 25V
Tr1	2N3702
Tr2	AD162 or similar - See Text
LP1	6V 40mA bulb - See Text
SW1	On-off switch
B1	PP9 9V battery

GRAM TO RADIO CONVERTER

This circuit is designed to convert an audio frequency signal to a modulated r.f. signal. Strictly speaking it is a very low power transmitter but it is not intended for that purpose - in any case it only has a range of a few feet. By using this circuit it is possible to make use of any radio for other purposes such as a record player or as a microphone amplifier.

Basically the circuit is a transistor connected as an r.f. oscillator which is modulated by an external audio signal. The transistor is arranged to oscillate at a frequency in the medium wave band and this is done by choosing the right values of inductance and capacitance for L1 and VC1. L1 cannot generally be bought as it is a centre tapped medium wave coil but it is not difficult to wind one's own. Eighty turns of wire should be wound onto a 3in. length of 3/8in. diameter ferrite rod. The gauge of wire used is not by any means critical but 32 s.w.g. is possibly about the best. The diameter of the ferrite rod and the length are similarly uncritical. The 80 turns should be centre tapped. This is best done by first winding on 40 turns, having first trapped the start of the winding in a band of sticky tape. At 40 turns a second band of tape is wound on the rod trapping the end. A large loop, about 3in. is then made in the wire which is then trapped in the tape again and the further 40 turns are made. The end is once again trapped in further band of tape. The loop should be twisted together, cleaned and tinned with solder.

This coil is tuned by a preset trimmer: the cheapest type and one which is very suitable for this type of circuit is the postage stamp compression type. The 250pF value shown will tune in the medium wave band but may not cover the whole frequency band. If it is desired to tune this to the lower frequency end, a 200pF fixed capacitor can be wired in parallel with the trimmer.

The coil is connected in the collector circuit of the transistor in the form of a Hartley oscillator. The centre tap on the coil goes to the positive line and one end feeds back to the base of the transistor via a capacitor to maintain oscillation. The value of this capacitor is not critical but to avoid too much distortion of the waveform it should be as low as possible while still keeping the circuit oscillating. The base bias for the transistor is supplied by R1.

The audio signal is applied at the emitter of the transistor which has R2 as a load.

As the audio signal adds to or subtracts slightly from the voltage at the emitter, this varies the applied voltage across the collector and emitter and this will mean that the level of the r.f. signal will also vary in sympathy with the applied signal. The inclusion of the resistor in

the emitter adds considerable negative feedback to the oscillator, this means that rather more feedback is needed in the oscillator than would normally be required. Also this feedback holds back the level to such a low value that the range is small enough to avoid interference to other radio users.

The output is taken from a short wire from the collector of the transistor and this is placed near the ferrite rod of the radio to be used as the amplifier. It is not usually necessary to get closer than a few inches and the best way is to tape the wire on the outside of the case. VC1 should be adjusted so that the signal is heard at a blank space on the dial. The radio itself will of course have to be tuned to the frequency of the oscillator.

The input level required is not high and either a crystal microphone or crystal pickup will drive the circuit. There will be a difference in the modulation level between the two but both will still be plainly heard.

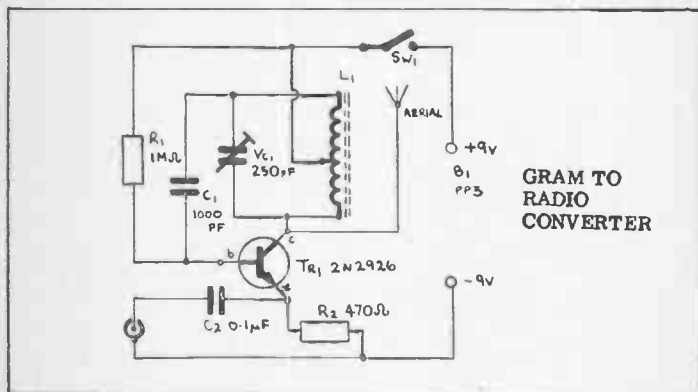

Components List

R1	1M ohms
R2	470 ohms
C1	1000pF See Text
C2	0.1 μ F
VC1	250pF postage stamp type preset.
Tr1	2N2926
L1	See Text
SW1	On-off switch
B1	PP3, 9V battery

INTERCOM

The most straightforward form of intercom would be to use a microphone feeding an amplifier which in turns feeds a speaker at the other end. When the remote end wished to contact the first station they would speak into a microphone which would drive a second amplifier at the remote end and this would be fed along the wires to the local station. However to avoid a "howl-round" occurring it would be necessary to ensure that only one end was speaking at the same time. Since this facility cannot easily be incorporated, we can make considerable economies in the circuitry by using just one amplifier and two speakers. The amplifier and one of the speakers is situated at the master station. At the remote station (often known as the "slave station") is situated only a speaker and a second battery.

Since we are using two speakers, which of course have low impedance, it is necessary to design a special amplifier which has both low input and low output impedance and also (for different reasons) one contact of each of the speakers should be common to the negative line.

Looking at the circuit we can see that the slave unit comprises simply of PP3 battery, a loudspeaker and an on-off switch. The negative side of the battery is connected to one side of the speaker and three wires lead to the master unit. These three wires can be of considerable length since there will be very little loss as the source impedance of the speaker is low, similarly with the battery; it needs a very long length of wire before the d.c. resistance is enough to cause any appreciable voltage drop.

In the standby position, with neither station making a call, SW1 in the slave unit is open. When the slave wishes to call the master this is closed and B1 applies voltage to the amplifier via one of the interconnecting wires.

In the master unit, on standby, SW2 is in the position shown and so the slave's loudspeaker is connected to the emitter of Tr1. This transistor is connected in the common base mode and the typical input impedance of a transistor so connected is low - about 50 ohms typical. This then closely matches the impedance of the speaker which (as will be seen from the component list) should be between 35 and 80 ohms. These impedances are quite common in small speakers. Large speakers could be used, they are generally more efficient, but this will make construction difficult.

The output of the first stage is coupled via C2 to a further stage of amplification, Tr2, which is connected in the common emitter mode. The collector load of this transistor is quite low and must also be accurately chosen. This stage connects to Tr3 which is an inverted PNP transistor. The collector of this goes via the switch to the local speaker and

in this way the speech at the remote end is heard without any local switching being done.

When the master wishes to call the slave unit, the switch SW2 is made. This firstly applies the local battery to the amplifier by SW2c. Secondly the output of the third transistor is switched to the remote loudspeaker and thirdly the local speaker is applied to the input of the amplifier. The same operation occurs but this time the speech locally originated is heard in the remote loudspeaker. The reason for referring to one of the units as the "master" is because the switch SW2 overrides the slave's switch. If the remote end makes the switch while the master is talking, all this does is to apply two batteries to the amplifier and no change takes place.

The current consumption of the circuit is quite high but this does not matter for an intercom is not likely to be used continually. Both of the switches should be spring loaded so that while talking the switch has to be held on; when the conversation has finished the switch is released and the unit is turned off.

The value of R4 is somewhat critical. This controls the bias on the third stage and it is important that the quiescent current is of the right level. If too low there will be severe distortion, if too high the quality will be lovely but the transistor will be drawing very high currents which will run the batteries down very quickly or even damage the transistor. The value of 82 ohms is a typical one but its actual value should be found by experiment; if necessary a variable resistor can be used in its place. The value should be the lowest one that is compatible with acceptable speech quality but should never be higher than 20mA if measured on a meter. Even this quiescent is fairly high and for this reason Tr3 should be fitted with a heat sink.

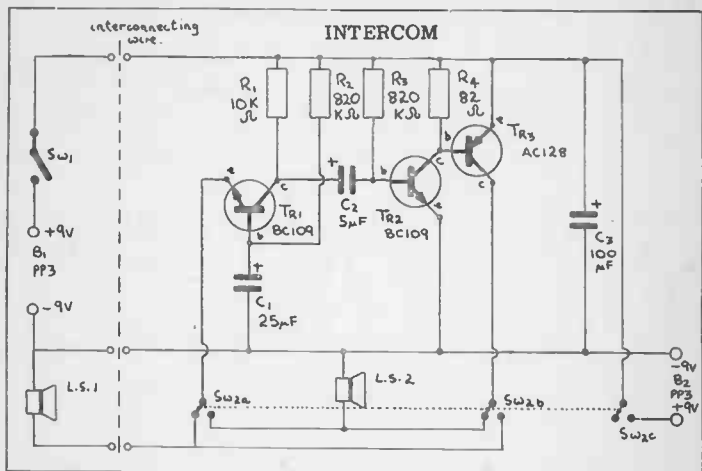

Components List

R1	10K ohms
R2	820K ohms
R3	820K ohms
R4	82 ohms - See Text
C1	25 μ F 12V
C2	5 μ F 12V
C3	100 μ F 12V
Tr1	BC109
Tr2	BC109
Tr3	AC128
LS1, 2	35 to 80 ohms miniature speakers.
SW1	Push to make, on-off switch
SW2	3-pole, two-way, spring loaded switch.
B1, 2	PP3, 9V batteries.

SOUND TRIGGERED FLASH

The introduction of inexpensive electronic flash guns has made possible a number of effects in photography. The duration of an electronically produced flash is of course very brief, normally about 1/500th of a second. If the camera shutter is left open in the dark or subdued light and the flash is made, it is the timing and duration of the flash which controls what is imprinted on the film rather than anything done by the camera.

Electronic flash guns are "fired" by making a switch and it can be seen that an electronic switch can do this job. If in turn this switch is activated by sound then some very interesting effects can be obtained. Using the prototype, a balloon at the instant of bursting has been captured for ever on film. A champagne cork leaving the bottle is another idea but the various gimmicks are limited only by the imagination.

The circuit shown is completely solid state and instead of a relay being used, a SCR is employed. This is cheaper and for this function just as good.

The first stage of the circuit is an impedance convertor. A crystal mike is used. Normally these have rather poor quality but in this circuit we are not too interested in quality, we are only using it as a device for converting sound into an electrical pulse. Tr1 is connected as a common collector stage; this has very high input impedance to correctly match the high impedance of the crystal microphone. The potentiometer VR1 is the emitter resistor and the sounds produced appear across this at a workable impedance. The output from this is fed to the conventional common emitter amplifier, Tr2 with VR2, a preset pot, as the collector load. The collector of this transistor is connected to the gate of the SCR via a resistor R3. For setting up the SCR is connected to a bulb, these two being across the battery supply.

When a sound is produced it is amplified by Tr1 and Tr2 and this causes Tr2 to draw rather more current at the peak of the sound. This reduces the voltage at the collector of the transistor and this is fed to the gate of the SCR. At the correct setting of VR1 this will cause the SCR to switch on and light will pass through the bulb. The bulb can be a 9V type but as these are hard to come by it can just as well be a 6V type with a 33 ohm resistor in series.

The bulb is used for setting up only. To continually trigger the flash gun in order to find the correct settings will be wasteful, especially as the flash tube has a limited life. Once the correct settings have been found, SW2 can be made and the SCR applied across the flash gun terminals. There are two variables in the circuit, VR1 and VR2. VR2 will normally only require setting once.

With the slider of VR1 at about a quarter the way up the track from the positive line, VR2 should be set so that the SCR just triggers on the loudest sound that can be made near the microphone. When this is done VR1 should give control over a wide range of sounds and acts as the sensitivity control.

The circuit should be tested to obtain the correct level setting of VR1 before every shot is taken with the test bulb in series. Once the correct settings are obtained the switch can be made to the flash gun having first made sure that the SCR is not on at that point. The SCR will stay switched on until the supply voltage is removed and so it is necessary to switch off the circuit using SW1 before switching over.

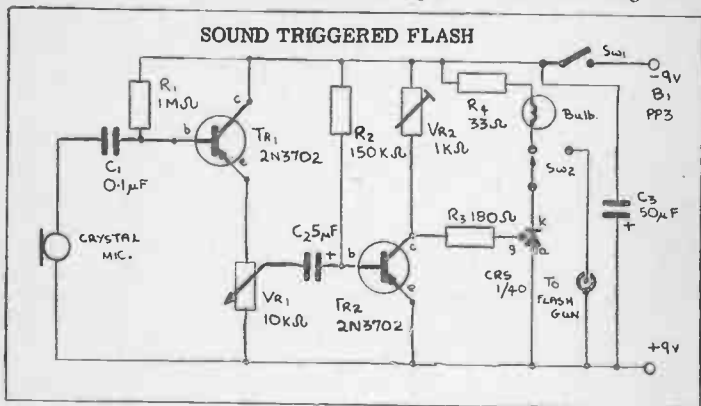

Components List

R1	1 M ohms	SCR	CRS1/40, 400V, 1A
R2	150K ohms	Crystal	Microphone
R3	180 ohms	VR1	10K ohms log. pot
R4	33 ohms	VR2	1K ohms linear preset
C1	0.1 μ F	SW1	On/off switch
C2	5 μ F 12V	SW2	One pole, 2-way switch
C3	50 μ F 12V	Bulb	6V, 40mA
Tr1	2N3702	B1	9V, PP3
Tr2	2N3702		

ELECTRONIC ORGAN

Until recently musical instruments relied on the vibration of strings or reeds but nowadays the loudspeaker is increasingly taking over. It is now possible for an organ enthusiast to have an instrument in his living room which a few years ago would have only been found in a cathedral. Proper electronic organs are pretty sophisticated devices - they comprise tone generators for the basic notes with dividers to provide a range of octaves. In addition 'voicing' is provided so that the organ can instantly be converted to give out sounds for a wide range of instruments. Such a circuit is of course very complex and costly to build and although kits are available even these are outside the range of most constructors.

Great fun, however, can be had using very simple electronic circuits. The one shown here covers over $1\frac{1}{2}$ octaves including sharps and flats and although only one note can be played at a time, nearly all tunes can be played and this is largely up to skill of the user. The advantage of this circuit over so many others of basically similar design that have appeared elsewhere is that there is no complex setting up procedure as far as getting the notes right is concerned. Fixed resistors are used and it is the value of these that determines the actual notes although there is preset to get those notes to the right part of the scale.

The circuit comprises two distinct sections, the tone generator and the vibrato unit.

The tone generator comprises Tr2, a unijunction transistor type 2N2646 together with C5, R5, VR1 and the tone resistors, R6 plus those resistors labelled Ra - Rn. The emitter of the unijunction goes to test probe which can select the correct notes and the frequency of the note depends on the total resistance in that chain. VR1 is a skeleton preset which alters the whole range. The output is taken from this oscillator via C6 to the volume control which should be connected to an external amplifier.

This circuit by itself will produce the correct notes and is a true electronic organ but the notes lack character and are not particularly pleasant. Character can be added by mixing with this note a low frequency a.f. signal known as vibrato. This works at a frequency which will lie in the range of 10Hz to 30Hz and it raises and lowers the level of the output very slightly at this frequency. This stage which comprises the components around Tr1 can be built separately at a later stage but it is strongly recommended that it is fitted. The oscillator is a phase shift type and the output is taken from the collector via C4 to feed directly to the emitter of the unijunction. In this way the low frequency note is not heard when the probe is not actually selecting a note. Phase shift oscillators can

sometimes be troublesome to get working but if trouble is experienced a small change in the value of R3, here shown as 1.8M ohms, will usually cure the problem.

It is important that the resistors specified in the components list for the tone notes are used. They may at first appear as slightly unusual values; they lie in what is known as the E24 series and such values can usually be bought at the larger component stockists. The range of the organ can be extended by adding further resistors but these will have to be found by experiment.

C5 in the circuit has a direct effect on the note and a good quality component should be used here.

It is possible to alter the vibrato frequency to suit personal tastes by altering the values of R1 and in fact a variable resistor could be used in its place. It is also possible to alter the level of vibrato applied to the unijunction by experimenting with C4 but if too high a value component is used this will affect the operation of the tone oscillator.

SW2 is included so that the vibrato can be removed if required. The current consumption of the circuit is not high and a PP3 battery will be sufficient. The simple amplifier described elsewhere in this book can be used with this circuit. This uses a PP9 battery and if built as a single unit, only this battery will be necessary.

Construction can take any form but note that the probe can not be just any piece of metal for if a poor contact is made - even for a fraction of a second, the organ sounds horrible. Various probes can be tried until one that makes a nice clean note instantly is found.

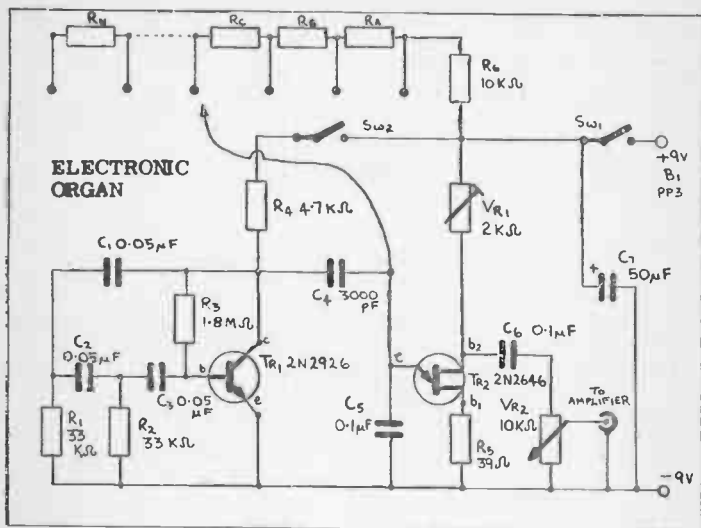

Components List

R1	33K ohms	SW1, SW2	On-off switches
R2	33K ohms	Note Scale Resistors - 5% - 1/8 W	
R3	1.8M ohms	Ra	1.2K ohms
R4	4.7K ohms	Rb	1.2K ohms
R5	39 ohms	Rc	1.1K ohms
C1	0.05 µF	Rd	1.1K ohms
C2	0.05 µF	Re	1K ohms
C3	0.05 µF	Rf	1K ohms
C4	3,000pF	Rg	910 ohms
C5	0.1 µF	Rh	910 ohms
C6	0.1 µF	Ri	820 ohms
C7	50 µF 12V	Rj	820 ohms
Tr1	2N2926G	Rk	750 ohms
Tr2	2N2646	Rl	680 ohms
VR1	2K ohms skeleton Preset	Rm	680 ohms
VR2	10K ohms log. pot.	Rn	620 ohms

METAL LOCATOR

Have you ever thought what people did with their money before the advent of banks? It's quite simple, they had to look after their money themselves and it was common practice to bury this money either in the garden or under the house so that robbers could not find it. This was the main method of holding money for 2,000 years and in that period literally thousands of people died without revealing the secret of the location of their hordes.

Also have you ever thought how careless we are with our money? The Royal Mint reckon that every year 150,000,000 coins are lost. Our generation is not the only one that is so careless with our hard earned cash. Every day dozens of Roman coins are found, there are so many in fact that they are worth very little. Excellent specimens cost only a couple of pounds while poor ones can hardly be given away; in fact many Victorian coins are worth more than some Roman ones.

All in all there is fortune laying in the top few inches of soil in Britain. Anyone who worked out the total would be rash but it has been estimated that if all the coins in one of the London Parks were found there would be enough to buy a house and an expensive car, which gives you some idea of the quantities involved, especially when one considers that the vast majority are low denomination types.

This is all very well, but how do you find them? The answer is by using a metal locator. All coins are made from some sort of metal and fortunately most are made from metals that do not corrode badly such as gold, silver, bronze or copper. It is quite possible to build an electronic device which will find metal buried in the ground to a depth of about 9 inches. The circuitry and construction are not particularly complex and commercially made metal locators are available from about £8.00 but you can make one for yourself for very much less, since it is the construction, not the component cost, that makes them complex.

Metal locators work in a number of ways but the principle that we are using here is the beat frequency. It has a number of advantages over the other designs and the principles are well established.

Beat frequency metal locators work as follows: There are two oscillators working at radio frequencies and both very close in frequency to each other so that when they are mixed there is beat note produced which can be heard as an audio note. Say one oscillator is operating on 465KHz and the other on 466KHz. When these are mixed together electronically an audio note equivalent to their difference is produced of 1KHz. If one of these oscillators alters frequency to 466.5KHz the beat note will change to 1.5KHz.

It is a simple matter to build an r.f. oscillator which will alter frequency in the presence of metal. A ferrite rod will greatly increase the inductance of a coil, but so will almost any metal. If the coil of one of these oscillators is wound in a special way, it can be arranged that the inductance will change whenever a piece of metal is brought within a few inches of it. So it will be seen that the beat note will also change thus indicating the presence of metal.

We shall call the two oscillators the search oscillator and the reference oscillator. The search oscillator is arranged to make use of the specially wound coil and this will change frequency when metal is brought near it. The reference oscillator frequency is not altered at all.

The Circuit

The search oscillator comprises those components surrounding Tr1. L1 is the search coil; the construction of this will be discussed later. Tr1 is connected as a Hartley oscillator. L1, the search coil, is connected in the collector circuit of the transistor and this is tuned by C1 and VC1. The centre tap goes to the positive supply line and the feedback is provided by C2 a 33pF capacitor. The value of this component is not critical and can be quite a bit higher. Base bias for this stage is provided by R1. This arrangement will oscillate at about 465KHz though the inclusion of VC1 allows the frequency to be varied over a wide range.

The reference oscillator comprises Tr2 and the associated components. This makes use of an i.f. transformer and is also connected as a Hartley oscillator. This will oscillate at about 465KHz depending on the position of the tuning slug.

The two oscillators are coupled by C3 which runs from the collector of Tr1 to the base of Tr2. This means that both frequencies are mixed in Tr2 and a beat note is produced. This appears in the collector circuit of Tr2 and is transformed by the secondary of IFT1 and couples to the base of Tr3 after being detected and smoothed. The signal is further amplified and applied to the headphones.

The building of such a circuit should present no real problems but a number of points have to be watched. If both frequencies are at exactly the same frequency no note will be heard so that before using it VC1 must be set so that there is a constant beat note heard in the headphones. There is a tendency for the two oscillators to lock together when their frequencies are too close together and the value of C3 may have to be reduced if this tendency is too marked. C3 may not be necessary at all and the stray capacity between the two stages may be enough to couple the two stages together; there is room for experiment here.

The construction of L1 is important as it determines the whole operation and it must be built with care. The second figure shows the general construction on a wooden former made up from a cross of wood, with a section of 1in x 1 in, as shown, each piece 6 in. long and half lapped. 20 turns of 32 s.w.g. enamelled copper wire should be wound on with a tap at 10 turns. The windings should be tight and once completed should be doped with a suitable cement to prevent vibrations causing a change in frequency. The wires running up the handle should be held tightly for the same reason.

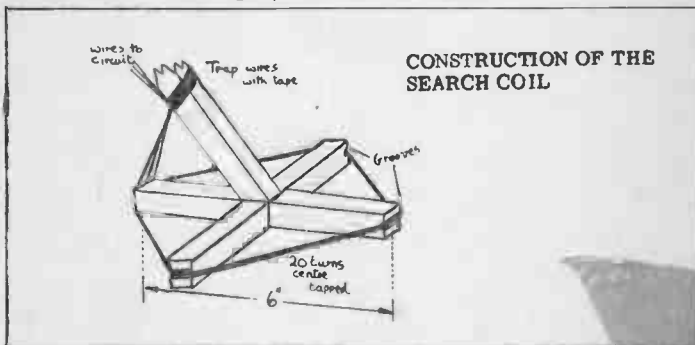

The search coil is "planned" over the ground until a change in the beat note is heard, this will indicate the presence of a metal object. There is considerable amount of skill involved in using a device of this type and several hours of practice will be needed to be able to find objects deep down, though metal near the surface will be found, if it is there, from the word "go".

METAL LOCATOR

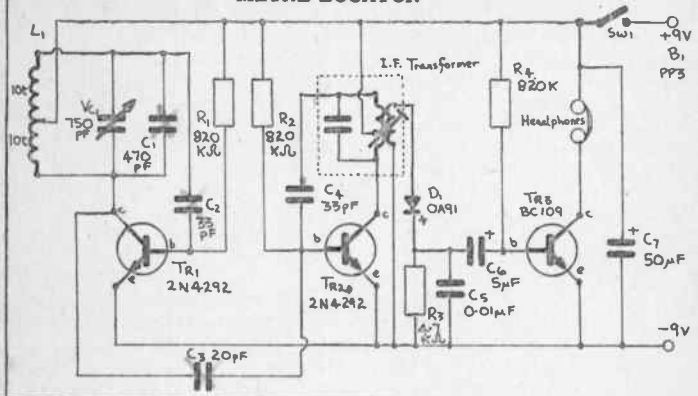

Components List

R1 820K ohms

R2 820K ohms

R3 4.7K ohms

R4 820K ohms

C1 470pF

C2 33pF

C3 20pF

C4 33pF

C5 0.01μF

C6 5μF 12V

C7 50μF 12V

VC1 750pF compression trimmer
used as variable.

Tr1 2N4292

Tr2 2N4292

Tr3 BC109

D1 OA91

L1 See Text

I.F.T. 465KHz transistor i.f.
Transformer

SW1 On-off switch

B1 PP3

High Impedance Headphones
(about 2,000 ohms)

INSECT REPELLENT

The title of this project may at first appear to belong more in the pages of a biology or a chemistry book, but we are not joking. It is possible to make life uncomfortable for certain types of bugs using electronics. The theory is quite complex though it is possible to give a rough outline of what happens.

It seems that mosquitoes and other nasty insects only mate at certain times and except for these times the two sexes are most unfriendly, in fact they stay well away from each other. It has also been reliably established that it is only the female of the species that actually bites; I have never closely examined a bug that has bitten me but I take the word of experts who know about such things! The third fact that we need to know is that the male mosquito (and this applies to other bugs as well) beats its wings at a slightly different rate than the female - this is one way that they identify each other. From these gems of information it will be seen that if one electronically simulates the sound of a male mosquito, the females will steer well clear. We are mentioning mosquitoes here but the same factors also apply to other bugs.

It is a very simple matter to simulate the noise of a male mosquito, all that is needed is a simple audio oscillator feeding an earpiece, the frequency has to be adjusted fairly accurately (you don't after all want to sound like a female and attract them!) and so a preset control is necessary. The sound level required is very low and a small earpiece is quite sufficient. In any case there would be strong disadvantages in producing the sound too loudly - it may even be more objectionable than the bugs.

The circuit shown is a simple audio oscillator whose frequency of operation can be varied over a wide range, in fact from about 500Hz to 10KHz and this will take in the range of all the common bugs. The circuit is a straightforward multivibrator with VR1 altering the audio frequency. This produces a square wave which is applied across the small crystal earpiece connected between the collector of Tr2 and the negative line. Crystal earpieces have a very high impedance and it will in no way affect the operation of the circuit. Pretty well any transistors can be used in this simple circuit but if PNP types are used the battery supply should be reversed. The values of the capacitors are not too critical either and if others are used and it is found that the frequency range is not adequate, R1 can be altered to bring it back to the right sort of range. The current consumption is low at 2-3mA, this varies slightly with the frequency, but a PP3 battery will last quite a while; after all the unit will have to be left on for long periods. None of the components need be large and the unit can be built in a small box to fit into a jacket pocket with the components arranged so that the earpiece is external. The preset VR1 should be a small skeleton preset with a facility for adjusting from outside.

As to adjusting for the right frequency this is a matter of trial and error. I have had some success by adjusting the note to that of a bug - in the hope that it was male, I must have been lucky for the circuit does seem to work.

I have not yet found out what happens if you try to use the unit during the bug mating season but I leave that up to the reader!

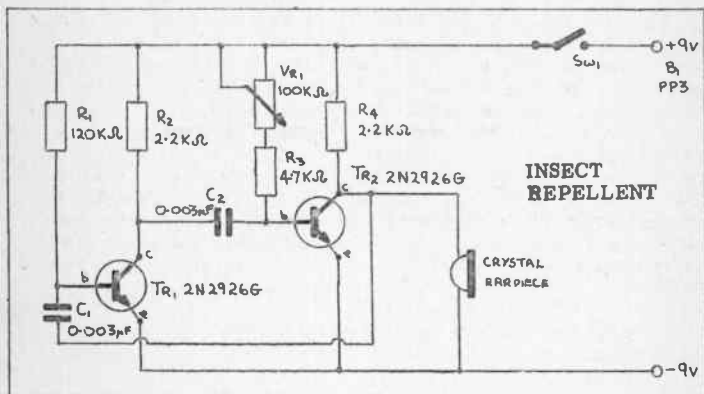

Components List

- R1 120K ohms
- R2 2.2K ohms
- R3 4.7K ohms
- R4 2.2K ohms
- C1 0.003 μ F
- C2 0.003 μ F
- VR1 100K ohms skeleton preset.
- Tr1 2N2926
- Tr2 2N2926
- SW1 On-off switch
- B1 PP3, 9V battery
- Crystal earpiece

THE "FASTEST DRAW" GAME

Have you ever wondered how your reactions compare to those of other people? This circuit is designed to do just that, it will show scientifically which of the two people playing the game has the most rapid reactions. It should be stated here that a person's reactions do not seem to bear any relationship to any other facet of their character. Some people who are generally considered to be dull-witted have very fast reactions and some bright and alive people have very poor responses. This is mentioned straight away in order that no one will try to draw unwarranted conclusions from the results. One or two facts do emerge however. The reactions of the young are very much faster than those of an older person and anyone who has had even a small amount of alcohol is at a distinct disadvantage.

There are two distinct parts to the circuit. Tr1 and Tr2 form a random indicator to signal the players to start in much the same way as a referee fires a shot to start an event, in this way the electronics provide an impartial starter. There are two alternative ways in which the start signal can be indicated. A loudspeaker can be included to produce a loud click or a light bulb can be made to switch off. Once the circuit is switched on there is a time delay before either of these happen and this time delay can be varied.

Tr1 and Tr3 are connected up as a Schmitt Trigger circuit. When the unit is off, SW1 is arranged to short out the capacitor C1. When SW1 is thrown C1 charges up through R1 and VR1. Initially the potential across C1 will be very low but at a certain point it will reach a level when Tr1 is beginning to turn on. This transistor will then start to draw current and so the potential across the emitter and the collector will fall, this in turn reduces the emitter-to-base voltage of Tr2, less current is then drawn by R3 so the voltage will drop at that point. This increases the emitter-to-base voltage of Tr1 which in turn switches itself further on. All of this takes place very quickly and this current is such that when Tr1 is on, Tr2 will be turned off and vice versa. The loudspeaker or bulb in the collector circuit of Tr2 will thus have a reduction of current passing through it. In the case of the loudspeaker this will result in a loud click and in the case of the bulb it means that it will stop glowing. When SW1 is turned off this shorts out C1 so that the game can start again.

The operational part of the circuit is very simple and comprises two transistors, two bulbs, three resistors and two switches. Each player has control over one of the switches, either SW2 or SW3. Say that SW2 is made first of all. This will mean that the supply voltage appears across the transistor which will be biased through R5 and LP3. When this transistor is turned on the voltage at the collector drops to very low level. If SW3 is then made it will also have the supply potential across it but R4, which provides the bias to the base, will have its other end at a very low potential and so the transistor can not be turned

on. The converse applies if SW3 is made before SW2. Whichever player makes his switch first also makes it impossible for the second player to light his lamp. This action is also very, very quick and even if there are imbalances in the resistors and transistors used these will not give any advantage to either player. It comes down to whoever makes their switch first, lights his own bulb and the action of the other switch becomes irrelevant.

The idea is that as soon as the signal from the starter is made, both players try to make the switch as fast as possible and the lighted bulb indicates who was faster, even if there is one ten-thousandths of a second separating them.

The reason for offering alternative start signals is that people's reactions vary with the type of stimulus. Some are fast with light and not with sound although there is usually very little in it but if two players are very evenly matched it will sometimes show that one is faster on one rather than the other. A small switch could be included to select either the loudspeaker or the bulb.

Another interesting effect that has been noticed is that some people are very much better than others if a long time delay is used, while they may not be good on short time delays. The knob on VR1 should preferably be of the type without any pointer and ideally it should be twiddled around by a third person (though this makes little difference). The time delay available is about 15 seconds with the loudspeaker and somewhat less with the bulb. If the time delay needs to be increased C1 can be raised in value. Note that the component chosen for C1 should have very low leakage and a tantalum type is to be preferred. If it does have high leakage the circuit may not work.

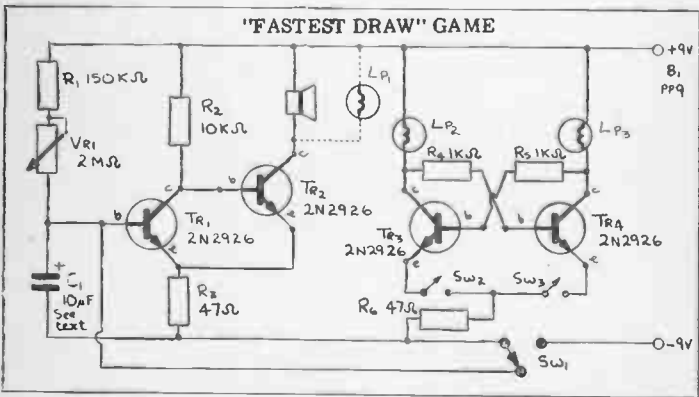

Components List

R1	150K ohms	Tr1-4	2N2926
R2	10K ohms	LP1-3	6V, 40mA bulbs
R3	47 ohms	LS	Loudspeaker - any type
R4	1K ohms	SW1	Single pole, two way toggle.
R5	1K ohms	SW2, 3	On-off toggle switches
VR1	2M ohms linear	B1	PP9, 9V battery
C1	10 μ F 10V - See text		

NOISE LIMITER

This circuit is particularly intended for those interested in DX-ing, that is, listening for distant radio stations. However, the same circuit has other uses such as reducing the scratch level on very old records (note that this is not the normal type of scratch filter circuit normally associated with Hi-Fi equipment). It also has uses in PA equipment where it can limit the input to the final stages and prevent overload distortion; distortion will still be present when an overload occurs but it is not as objectionable as that usually produced.

The circuit is designed to take almost any audio input but the output will have all peaks above a certain level, which can be adjusted, eliminated. Anyone who has listened to a really weak radio signal will know the limitations imposed by the noise. At any one time there are literally thousands of thunderstorms taking place somewhere in the world and sensitive receivers will hear lightning a considerable distance away, often the level of noise is much higher than that of the radio signal that is wanted. Apart from lightning there is more local interference such as that produced by poorly suppressed motor cars or electric motors. With a powerful radio signal these are just not noticeable since the noise level is well below that of the radio signal but on distant stations the noise level all but buries the signal.

The circuit can either be wired into a receiver circuit or directly from a headphones socket in which case the headphones are wired to this unit instead. If wired into a circuit permanently, VRI should take the place of the normal volume control and the output should be wired to the point which was previously connected to the volume control slider. An extra control plus a switch will also have to be mounted on the receiver front panel. The circuit can either be left in permanently as at most settings it will not affect the signal or it can be switched out.

The output of the receiver, which as we have said can be from the volume control or the headphone socket, is taken to the input and amplified by Tr1 which is connected in the common emitter mode. This transistor will considerably increase the audio level and this is applied via a d.c. blocking capacitor, C2 to the two silicon diodes D1 and D2. In the normal way these diodes will not have any bias voltage applied across them and so they will present a high resistance, and will not affect the output in any way. However, as soon as the output from the amplifier exceeds about 0.6V, the diodes will conduct and short the output to the negative line. Two diodes are needed, one connected each way around, so that both positive and negative going peaks are shorted out. The idea of the amplifier is to make sure that whatever the input level across VRI, it can be amplified so that at least 0.6V can be applied across the diodes. Since VR1 is adjusted so that the level is always the same a volume

control has been included in the circuit so that the output level can be controlled in the usual way; this is accomplished by VR2.

To limit the noise the input level is increased until the audio signal that is wanted is just distorting and then backed off slightly so that no distortion is heard on the peaks of the audio part of the signal. This will then mean that any audio peaks above that level will hardly be heard in the output as the peaks above the preset limit will be conducted to the negative line, VR2 is then adjusted as a normal volume control. If VR1 is adjusted well below the limiting level and VR2 is adjusted for normal listening levels, the circuit has no effect. However, it is a simple matter to include SW1 which will bypass the circuit. The supply voltage can be taken from a battery as shown in the circuit, the current drain being very small, or from the receiver's supply. If this is transistor operated with 9V then there will be no difficulty but if the receiver is a valved type or uses a supply potential higher than 9V then a suitable dropping resistor from the h. t. supply rail will have to be included. The value will depend on the supply voltage but for 250V a resistor in the order of 150K ohms will be about right; this should be connected between the h. t. line and the slider of SW1a.

The effect of the noise limiter is quite remarkable and by switching the circuit in and out it is possible to compare the results. The noise will still be there but not at an annoying level and the signal will be very, very much clearer.

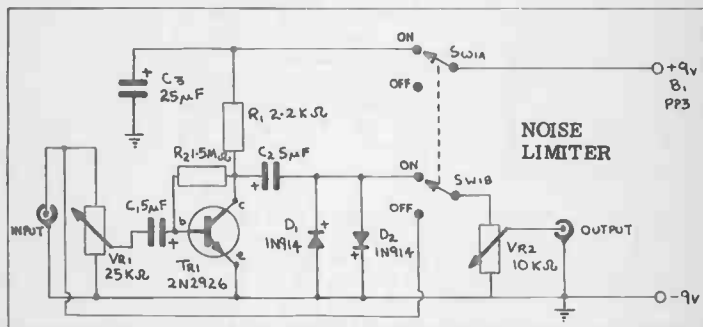

Components List

R1	2.2K ohms	C3	25 μ F 25V
R2	1.5M ohms	Tr1	2N2926
VR1	25K ohms log. pot	D1, D2	1N914 silicon diode
VR2	10K ohms log. pot	SW1	Two-pole, Two-way switch
C1	5 μ F 12V	B1	PP3, 9V battery - See Text
C2	5 μ F 12V		

BURP BOX

Of all the circuits that are included in this book, rather surprisingly this one has probably created the most interest among friends. Originally the circuit was built as quick lash up but because it was so popular, especially with children, it is still in everyday use. Exactly what it does is hard to describe fairly and since it is difficult to explain the effect in words and so many components are used the reader may well be put off. The results of this circuit can only really be appreciated by listening to final results.

The circuit comprises three multivibrators, all working at very different frequencies. They are supplied by a common positive supply rail which is deliberately not decoupled and the inclusion of the resistor Rx in the line enables the multivibrators to be coupled together.

A transistor output transformer and speaker are coupled in the collector circuit of Tr6 and it is from this that the output is heard.

All the multivibrators are working together at the same time and they can all have their frequency of operation altered over a wide range controlled by the settings of VR1, VR2 or VR3.

Tr3 and Tr4 are producing a high frequency, Tr5 and Tr6 are producing a very low frequency which does not repeat for several seconds while Tr1 and Tr2 are producing an intermediate frequency.

What may at first appear to happen is that due to lack of decoupling the combined frequencies would appear at the loudspeaker at rate approximately equal to the rate of the third multivibrator. In fact, the results are much more interesting. What actually happens is that the stages each have an effect on the others and they synchronise each other in an extraordinary way. Due to the three controls an almost infinite variety of sounds can be produced.

For instance a typical output may consist of a short burst of tone followed by a second of silence - this is then followed by a series of clicks followed by a low frequency note, then more silence and so. The patterns often do not repeat themselves for several seconds. The combinations and possible varieties are quite remarkable and on the prototype some of the sounds have sounded uncannily like that of animals or machines. At first sight it would seem possible to reproduce these again and again by noting the settings and duplicating these later but unfortunately this is rarely possible. Each tiniest part of a turn on the controls changes the pattern and sequence - often to a considerable extent.

The resistor Rx should be selected for maximum effect - its value will depend on the characteristics and values of the components used and so it is not possible to give a single best value but 47 ohms is a good one to start with.

The supply lines are all joined to one point and the addition of further resistors here will also effect the output - here again their values will depend very much on the components used and once again a value of 47 ohms is a good one to start with.

All the transistors specified are shown as BC109's but for this sort of project the surplus transistors which are sold in 50p packs are ideal. Initially tested transistors can be used to ensure that each individual circuit works and once operation established these can be replaced by surplus types.

As a circuit configuration the multivibrator is remarkably tolerant with regard to transistor types.

There is no need of course to limit the number of multivibrators to three. Four or more will add yet further effects but three will still give plenty of range.

If an amplifier is available it is possible to make a simple change which will increase the range. If T1 is replaced with a 2.2K ohms resistor, a low level audio output can be taken via a 0.1 μ F capacitor from the operational side of Rx to an amplifier, of course a wire should also join the two chassis lines together. In this way even more effects can be heard.

It is understandable that anyone seeing the circuit and reading a rather inadequate description of what will be heard may be hesitant but the pleasure and interest that the prototype has created testifies to the fact that this is a thoroughly worthwhile project - it is for amusement only but that should be a recommendation, not a criticism.

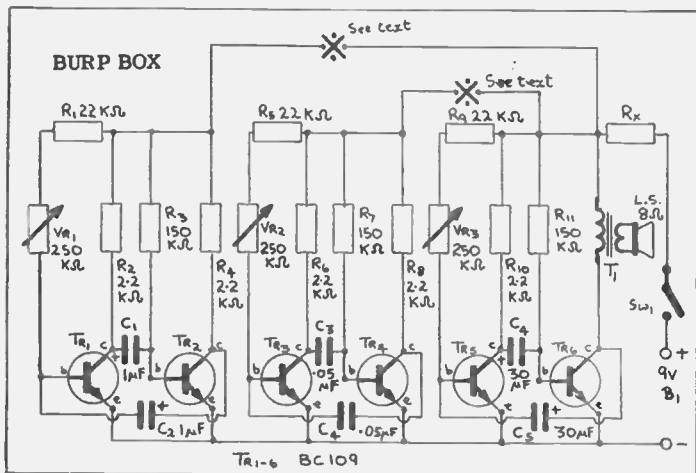

Components List

R1	22K ohms	C1, 2	1 μ F 12V
R2	2.2K ohms	C3, C4	0.05 μ F
R3	150K ohms	C5, C6	30 μ F 12V
R4	2.2K ohms	Tr1-6	BC109 - See Text
R5	22K ohms	Tr1	Transistor output trans- former
R6	2.2K ohms	LS	8 ohms loudspeaker.
R7	150K ohms	SW1	On-off switch
R8	2.2K ohms	B1	PP9 9V battery
R9	22K ohms		
R10	2.2K ohms		
R11	150K ohms		
VR1, 2, 3	250K ohms linear pots.		
Rx	See Text		

AUDIO FILTER

This circuit has uses in several fields but perhaps its greatest use is when DX-ing, that is listening to radio stations a great distance off. The circuit is designed to all but eliminates a very narrow band of audio frequencies while unaffected the other audio frequencies. Using the component values shown the actual frequency eliminated can be varied from about 100Hz to 20KHz.

Radio stations should all operate on a specific frequency band. In Europe on the medium wave band there is a station every 9KHz (8KHz at the high frequency end) and on the short waves every 5KHz. If there are two stations operating on exactly the same frequency this is annoying but the more powerful station will usually drown the less powerful one. Unfortunately many stations do not operate on the allocated channels and these create a beat frequency in the audio range which is very annoying. Even if one station is much more powerful this heterodyne is still heard. The audio frequency will be the difference between the two r. f. frequencies and will always be the same and so the inclusion of this circuit in the audio stages can eliminate this overpowering heterodyne. In use it has also been found useful for a less obvious purpose. If two signals are right on top of each other and one is transmitting music while the other is on speech, it is possible to set the filter to at least partially deaden one or other of the signals. If it is set for say 1KHz this will have very little effect on speech but at least a proportion of the music will fall into this range. Although the filter is sharp, that is it will show a marked effect at one spot frequency, it will also attenuate adjacent frequencies to a lesser extent. Even if the filter is put right in the middle of the speech frequencies it is remarkable how little effect it has on intelligability, the brain takes care of those missing frequencies.

The filter is not perfect but this is not due to any inefficiency on its part. Nearly all receivers create some harmonic distortion and the audio stages are rarely up to Hi-Fi standards. The filter will only eliminate the fundamental frequency but the harmonics remain and these will still be heard - albeit at a much lower level. As the control is tuned the heterodyne has the appearance of raising the frequency at the exact point of null.

The circuit comprises two transistors. All the action takes place around Tr1 but the output must be connected to a high impedance and for this reason an emitter follower circuit is used, the output being taken from the emitter resistor. The circuit has no gain, in fact the output will be very slightly less than that fed in but all that is necessary to overcome this is to increase the volume control.

When the signal is fed to the first transistor there are two outputs, one from the emitter load, the other from the collector load. These will be in a different phase and assuming that VR2 is set correctly, they will also be of the same amplitude. VR3 together with C3 and C4 form a frequency sensitive network and at the frequency determined by the setting of the control, the signals will be of exactly the same amplitude and out of phase with each other; they will therefore cancel and no output will be heard. At other frequencies one or other of the feeds from Tr1 will be dominant and these are hardly affected. The common point is connected to C5 which connects to the impedance matcher Tr2. The output is taken from the emitter load.

To set VR2 it is necessary to feed a constant audio frequency in, this must be a sine wave as other wave shapes all contain harmonics and these will not be affected to any degree. Varying VR3 will indicate a point at which a marked fall in level will occur. The setting of VR3 should be set for absolute maximum attenuation and then VR2 is set for a further minimum level. The setting of VR2 will depend on the actual frequency but only tiny changes are necessary and it may not be considered worthwhile to adjust VR2 each time, instead finding a compromise setting which is pretty good at all frequencies and perfect at one particular one.

The operation of VR3 is far from linear. On the prototype the lowest frequency was 100Hz as the mean null point and the highest frequency was outside the audio range at about 20KHz but half scale on VR3 is only 250Hz, the higher frequencies being severely compressed. This is not too troublesome however as nulling out will not have to be done except when the frequency changes.

The circuit will handle a wide variation of inputs - the filter does not depend on the input level and it can handle 500mV with no trouble. If the input is overloaded this will cause overload distortion and as mentioned, the circuit will not eliminate the harmonics. For this reason a level control is included at the input. It is not necessary to switch the circuit in and out of the circuit as setting VR3 at the highest frequencies will mean that the circuit will have no effect on the operation.

The circuit can be wired in several places in a radio circuit but the most convenient is to replace the volume control with VR1 and make the old volume control the emitter resistor of Tr2. The value of this emitter resistor is not critical within reasonable limits and can be up to 25K ohms. If the radio is a valved one, the volume control will be much higher in value than this and in this case R6 should be included with the existing volume control connected in parallel with it.

The current consumption is not very high and the supply voltage can be taken from the h.t. supply via a suitable resistor to drop the voltage to the necessary 9V. A battery can be used but this is a bit of a waste if power is already available.

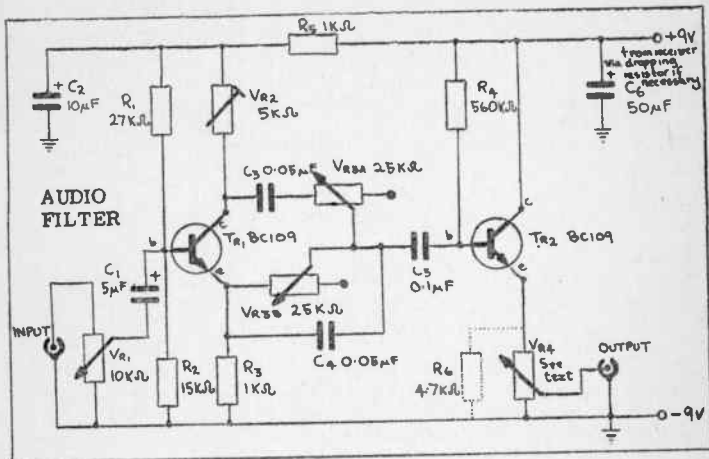

Components List

R1	27K ohms
R2	15K ohms
R3	1K ohms
R4	560K ohms
R5	1K ohms
R6	4.7K ohms - See Text
VR1	10K ohms log. pot.
VR2	5K ohms preset skeleton pot.
VR3	25K ohms plus 25K dual pot, linear.
VR4	See Text
C1	5µF 12V
C2	10µF 12V
C3	0.05µF
C4	0.05µF
C5	0.1µF
C6	50µF 12V
Tr1	BC109
Tr2	BC109

RAIN/WATER ALARM

This simple circuit can either be employed as a water level alarm or as an indicator that it is raining outside. Certain homes are prone to flooding in their basements and automatic pumps are available on the market which come into operation as soon as the water level rises. Other people live near rivers which can overflow at certain times. The same circuit, with no modifications can be used to give mum a warning that if she doesn't move quickly, the washing, which is supposed to be drying on the line, will soon be wetter than it was when it was put out.

As with all alarm circuits reliability is paramount. Alarms are by their very nature rarely used but they must work on the odd occasion that they are called upon to do so. For this reason they should employ only solid state circuitry, for although relays are pretty reliable, the contacts do occasionally get dirty. For the same reason a mains power supply is to be preferred over a battery. The unit will, of course, work perfectly well on batteries but eventually the battery will go flat and it is an easy matter to forget to change it. The current consumption is minute in the standby condition - a few millionths of an amp so that the cost of running the unit from the mains will amount to practically nothing.

The circuit makes use of the conductivity of water. Water is a fairly good conductor of electricity - nothing like as good as metals but still good. Even rain water which is very pure has a low resistance compared to that of materials that we normally consider to be insulators. However it would not be practical to rely simply on this resistance for our alarm circuit since the conductivity of the water depends on several factors. The alarm circuit will work if almost any resistance below a reasonable level is created. The circuit shown will in fact operate in a very similar way if the resistance falls in the range from a short circuit to 10M ohms. There is a slight difference in the frequency of the alarm note produced but this is of no importance. The higher resistances produce a lower note while the short circuit produces the highest.

The alarm part of the circuit is made up of Tr2 and Tr3. These are connected as a form of multivibrator - not the more usual configuration but still a multivibrator. When there is a very high resistance between the base of Tr2 and the negative line, the only current drawn is that of the transistor leakage, and, since the types shown are all silicon, this will be of a very low level. When there is a resistance the circuit will oscillate at audio frequencies and the note will be heard from the loud-speaker. The output is in the form of a series of pulses and this makes maximum use of the speaker, the output being of quite a high level.

To make this circuit operate when water is present we include Tr1. The sensors across which the water is made to bridge are in the collector-base circuit. The inclusion of R1 prevents a direct connection even in short circuit conditions to protect the transistor.

The water provides the bias for this transistor and when this is conducting it forms an electrical path from the base of Tr2 to the negative line via R2, a second 47K ohms resistor. Whatever the bias applied to Tr1 it will make the transistor appear as a low resistance compared to R2 and it is this which makes the actual resistance across the probes of little importance.

SW1 is arranged to have three positions, off, test and on. The on and off positions are obvious but the test position is included as it will be a chore to have to wet the probes each time to see if the battery (if that is used) is in good condition. Even if a mains operated power supply is used, this function can be included.

The probes can take a wide variety of forms. For sensing water across them they can be two bared wires which are bridged by the water. For a rain alarm it is important that this contact is made very soon after it starts raining and that even fine drizzle bridges the contact. A piece of cloth about 3in. square has been found to be quite good. This acts as blotting paper and if two bared wires are mounted on two opposite sides the first drop of rain will spread across and create the conduction path. A material that does not rot is desirable.

Another convenient place to mount the rain sensing probes is at the outlet of a gutter down pipe. The gutter then acts as the rain gatherer and gives a warning earlier than might otherwise be obtainable.

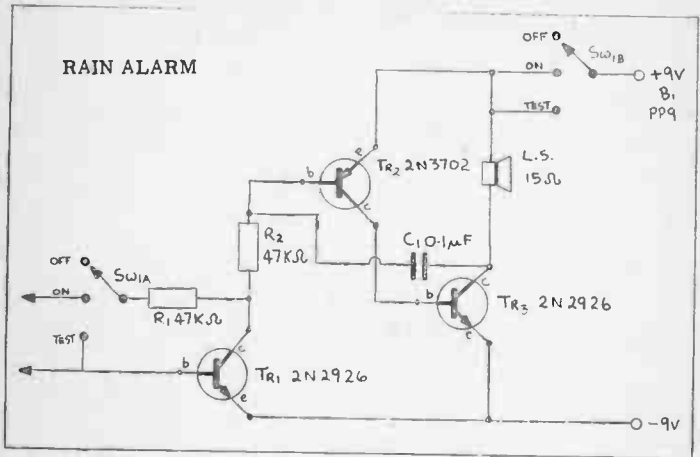

Components List

R1	47K ohms
R2	47K ohms
C1	0.1 μ F
Tr1	2N2926
Tr2	2N3702
Tr3	2N2926
LS	15 ohms loudspeaker
SW1	2-pole, 3-way rotary switch
B1	9V, PP9 battery - See text

MAGIC CANDLE

Electronic party tricks are always popular. The majority of people have very little understanding of electronics and even simple tricks can mystify them. This circuit, a "Magic Candle" uses only a handful of common components and can be built very quickly. However, as with many projects of this type, the ingenuity in building is probably more important than the circuitry, this however is left to the reader though some general tips are given later.

The idea of the "Magic Candle" is to demonstrate that lightbulbs can be lit by a match or cigarette lighter and can be snuffed in a similar way. The bulb should be the only item that is actually showing but it is important that the LDR - light dependant resistor - is very close by with the active face pointing at the bulb. When a match is struck and brought up to the bulb this causes light to fall on the LDR rather than the bulb. This causes the resistance of the LDR to fall considerably and since this forms a potential divider with VR1, which is coupled to the base of the transistor, the voltage here rises and causes the transistor Tr1 to conduct. This causes current to flow through the bulb which in turn lights up.

When the match is withdrawn the light from the bulb takes over as the source which keeps the resistance of the LDR low and so the transistor will remain on and the bulb will stay alight. If now the bulb is "snuffed" by breaking the path of light between the bulb and the LDR, the bulb will go out and remain so until the light level once again reaches a sufficient brightness to turn the transistor on.

The use of a 6V bulb is simply because these types are widely available and cheap and in order to prevent too high a voltage being applied the resistor R1 is connected in the emitter circuit. In the conducting stage there is only a tiny voltage drop across Tr1 but about 3V will be dropped across this resistor thus ensuring that the bulb is not overdriven.

Since the circuit will have to operate in widely differing light levels, it is necessary to control the sensitivity of the circuit and this is accomplished by VR1. In high ambient light levels the value of VR1 should be low, this means that the transistor will remain switched off until the light level created by the match goes above this level. In low light levels the value of VR1 will be high.

VR1 can take the form of a miniature preset control which for normal uses can probably be left at some level found experimentally for general purpose use. It is not possible to give even an indication of this value as the resistance of light dependant resistors varies considerably with the individual specimen.

The current drain is 40mA which is rather heavy for a PP3 battery though one in good condition will work for a short period. The heavy current drain may be acceptable as the circuit is unlikely to be on for long periods and this battery has the advantage of being small in physical size and cheap. SW1, the on-off switch can take any convenient form, it may even be omitted, the circuit being switched off by removing the battery clips.

As we mentioned before the bulb should be the only thing that observers can see, all the other components being hidden in a small box on which the bulb is mounted. An LDR is about 5/8 in. in diameter though even this can be well disguised since the active surface is rather smaller and in any case not all of it has to be exposed, even a 1/4 in. diameter hole should be sufficient and this hole should be close to the bulb and pointing at it. It must of course be possible to easily interrupt the light path between the bulb and the LDR in order to "snuff" it.

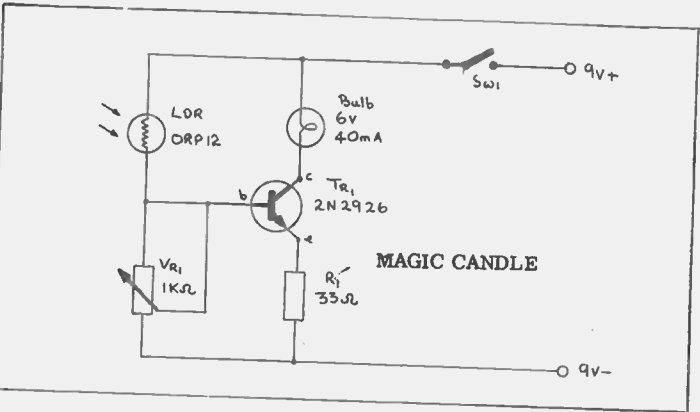

Components List

- R1 33 ohms
- VR1 1K ohms lin. preset pot.
- LDR Light dependent resistor, ORP12 or similar.
- Tr1 2N2926
- SW1 On-off switch - See text
- Battery See Text

KIDDIES TOOTER

Anyone who has small children will know how fascinated they are with noise. Banging a drum or rattling tin cans can keep them happy for hours on end. This can of course be very annoying for not only does the long suffering parent get very impatient (quite understandably) but they also have little control over the volume of the sound produced.

This circuit has been designed to overcome both problems while at the same time keeping the child happy. When built the circuit can be fitted into a plastic box with a series of push buttons on top. When switched on, the pressing of these buttons will produce a range of notes of various frequency. Pressing two buttons will produce yet another different note, three will produce yet another. The actual number of different notes provided is up to the constructor. Fewer than four leads to monotony and the child will quickly get bored and five - or even more - seems to be a good number - 120 notes can be produced using five.

The circuit is simply a conventional multivibrator using two cheap transistors. Using the component values shown the circuit will oscillate in the audio range and since an output transformer and a speaker are connected in one of the collector circuits, this frequency will be heard in the loudspeaker.

The frequency depends on virtually all the components, if any of them are changed there will be a change in frequency but the largest changes are brought about by altering the bias resistors for one of the transistors; here the bias resistor for Tr1 is changed and by arranging for a variety of different values to be selected by the switches, the note will be varied. The highest note will be produced when all the buttons are pressed and the lowest when the single highest value resistor is selected. The values of R1 to R5 can be selected at random but should lie within the range 27K ohms to 820K ohms. Almost any transistors can be used in this circuit with no changes in the component values. If P-N-P types are to hand it is only necessary to reverse the battery polarity as no electrolytics are used.

The output is in the order of 50mW - sufficient to keep a child amused yet not loud enough to be annoying. If a particular efficient speaker is used, or if this low output is still found to be annoying, a resistor can be wired in series with the output transformer - its value will be a matter of personal choice but one of a few hundred ohms will reduce the output appreciably. Remember however that if the output is very low the child will quickly lose interest.

The current drain is not high at about 15mA and batteries will last a fair time - they may have to for many children will never bother to turn it off. For a child who is likely to leave the unit switched on for long periods the on-off switch can be of the same type as used for the note selectors that is, push to make, release to break, these switches are inexpensive and are widely available.

The unit can be built on Veroboard and fitted inside a small plastic box with the note selectors on the lid and the on-off switch on one side. If the unit is intended for a very small child the lid should be fitted on in such a way that access cannot be obtained without the use of a screw-driver. No harm will befall the child from the battery - this is quite safe - but prying fingers could easily get cut on sharp components.

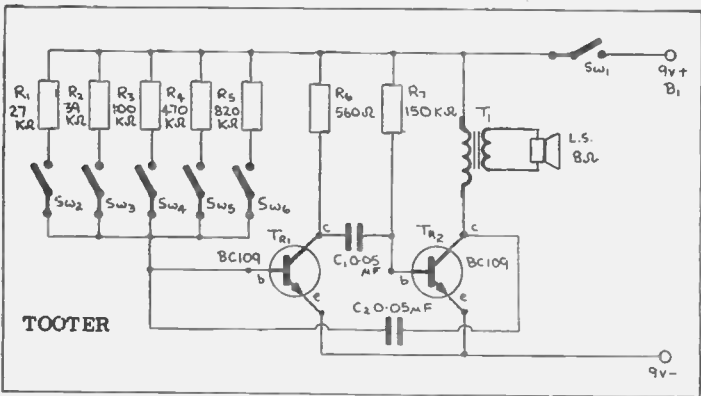

Components List

- R1 27K ohms
- R2 39K ohms
- R3 100K ohms
- R4 470K ohms
- R5 820K ohms
- R6 560K ohms
- R7 150K ohms
- C1 0.05 μ F
- C2 0.05 μ F
- Tr1 BC109
- Tr2 BC109
- T1 Transistor output transformer
- Speaker, miniature type, 8 ohms
- SW1 On-off switch
- SW2-SW6 Push to make, release to break.

SUPER HIGH INSULATION TESTER

We are accustomed to talk about conductors and insulators of electricity as though these were definite quantities. In fact the resistance of materials varies between superconductors, which at near absolute zero temperature are virtually perfect conductors of electricity, through copper and aluminium which are very good conductors, to semiconductor which have a typical resistance of 1 ohm per cubic centimeter. At the high end there are the materials used in electronics for component encapsulation and dielectrics in capacitors. Of course there are several grades which are not mentioned and lie somewhere in between but the scale is a continuous one. In some fields of electronics, aluminium is considered to be a poor conductor and in other fields waxolin and like materials are considered to almost conduct. For the ordinary experimenter it is rare that the normal materials used in construction have any effect on the circuit but there are occasions when it is useful or necessary to be able to either measure or at least compare very high resistances. The very high gains of some transistors now available mean that a resistance of 10M ohms between the base and collector will affect the circuit operation and the old fashioned form of construction called "breadboarding" is not suitable.

This circuit is capable of showing a meter indication for extremely high resistance, it can also be used for the measuring of the moisture content in wood or sand. It can identify leakage paths that would otherwise be very difficult to find.

These high resistances could of course be measured by using a very sensitive meter, say one with an f. s. d. of 50 microamps, in conjunction with a high voltage, say 250V, but even this would give a centre scale reading on the meter of only 10M ohms and such a system would be difficult (and dangerous) to use.

An alternative is to use the circuit shown. This comprises three identical transistors in conjunction with a relatively insensitive meter (1mA) in a conventional ohmmeter circuit. The secret of the operation is that the resistance is not measured directly but is virtually divided by the gains of the transistors to give a realistic reading on the meter. No high voltages are used, the battery being a common 9V, PP3

If we were to take just two of the transistors, these would form a Darlington pair and to understand the operation it is much easier to consider just two transistors. When this is understood the operation of the third becomes obvious.

Let us assume that Tr2 and Tr3 are the only transistors and that the probes are connected between the common collector point and the base of Tr2. Now Tr2 is itself in the collector base circuit of Tr3 and the bias for Tr3 is provided by the emitter-collector junction of Tr2. If we regard a transistor as a resistor whose ohmic value depends on

the value of the bias applied, the position becomes clear. A very high resistance between the base and collector of Tr2 lowers this transistor's effective resistance which in turn lowers the resistance of Tr3 which allows more current to pass through the meter thus indicating the value of the resistance applying the original bias of Tr2.

All we are doing here is to take matters one stage further by including a third transistor. The circuit depends on the use of very low leakage transistors and silicon transistors must be used; the leakage of germanium types would make the circuit unuseable.

The calibration of the scale will depend on the gains of the transistors used but calibration is rarely needed, such a circuit will almost certainly be used for comparative rather than direct readings but resistors with values of tens of megohms are available and these can be used for calibration if desired.

The inclusion of the resistor R1 is to protect the meter. If it were omitted the meter could be badly overloaded. A switch is shown but this could be omitted as the leakage of the transistors is far less than the natural decay of the battery but its inclusion does prevent drain should the sensors be accidentally left in contact. For zeroing the meter, if this is found to be required, R1 could be made a variable.

The sensitivity of this circuit is remarkable and it also demonstrates what excellent insulators are used by manufacturers for the construction of transistors as only the tiniest of readings will normally be shown, if any at all. Even breathing on the transistor Tr1 will cause a massive deflection on the meter. It is also important that the material between the base and collector of Tr1 is absolutely clean as even dirt will be shown as a reading.

This circuit is very interesting from an experimental point of view and allows the user to enter a field of measurements which would otherwise be all but impossible.

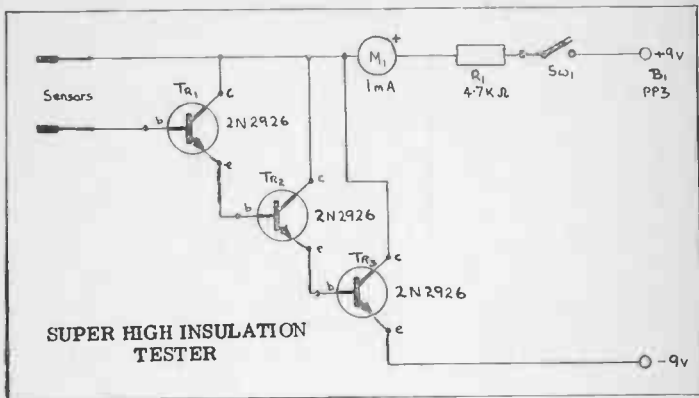

Components List

Tr1, 2, 3	2N2926
Meter	1mA moving coil meter
R1	4.7K ohms - See Text
SW1	See Text
B1	PP3, 9V battery

LIE DETECTOR

It is well known that a person perspires under tension; what is less well known is that this effect is a gradual one and that a small amount of perspiration takes place, especially in the palms of the hands, even under slight pressure. In the normal course of events this is rarely noticed but this effect can be shown electronically.

When a person is embarrassed or tells a lie there is a very small, but noticeable, increase in the sweat on the palms of the hands. Perspiration is reasonably conductive; holding the probes of a testmeter in the hands will show a resistance reading, albeit at a high level. It will therefore be seen that by measuring the resistance across a person's hands that we shall be able to see an indication of whether they are telling the truth or not. Let us say straight away that this test is far from perfect and it has little serious use but it does illustrate an interesting phenomena and makes room for a little experimenting.

The change in the body resistance is quite small when shown as a percentage - about 5 or 10 per cent and showing this change directly on a meter leaves something to be desired. For this reason we make use firstly of a transistor to "amplify" the resistance and secondly we place this in a bridge circuit. When this is in balance the meter will only read changes in the resistance.

When the probes are held, one in each hand, the body resistance, in conjunction with R2, provides the bias for the transistor. The body resistance varies enormously from person to person as well as with their emotional state but a typical value could be taken as 100K ohms. R2 is included solely as a safety resistor and will prevent damage to the device if the probes are touched directly together. The current passing through this transistor and through R1 will depend upon the value of the resistance between the collector and emitter. As the current varies, so will the voltage at the collector.

For setting up the circuit the probes should be held in the hands. This will give a particular voltage and VR1 is adjusted so that the voltage at the slider is the same as that at the collector of the transistor. As the voltages are the same, no current will be flowing through the meter coil and no reading will be registered.

If the body resistance now falls, Tr1 will conduct more and the voltage at the collector also falls and a reading will be shown on the meter, the size of the deflection will indicate by how much the body resistance has fallen.

Although the probes are held in the hand, there is no danger as only a 9V battery is being used. VR1 will have to be adjusted for each individual and even for each set of readings with the same person.

The effect is quite remarkable and also surprisingly rapid; within a very short while (one or two seconds) the meter will show a deflection. There may be a small amount of wandering of the needle but this will be small compared to normal readings.

As we have said, the results should not be taken too seriously but very definite readings are given when the person being tested is under stress.

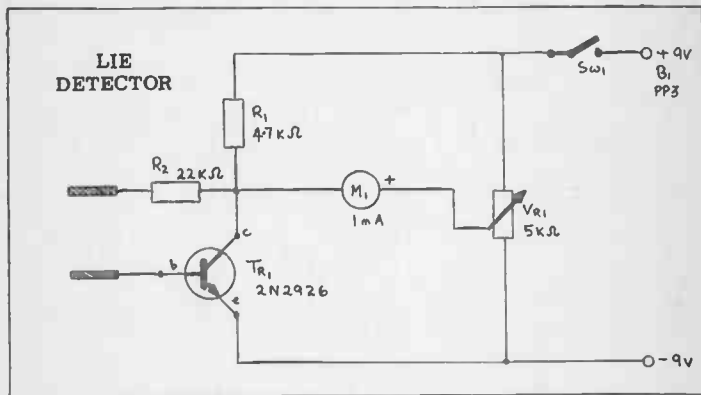

Components List

R1	4.7K ohms
R2	22K ohms
VR1	5K ohms ln. pot.
Tr1	2N2926
SW1	On-off switch
Meter	1mA moving coil
Battery	9V, PP3

TEMPERATURE ALARM

There are a very large number of electronic components which are designed to sense a change in the environment. Microphones sense a change in the noise level, LDR's a change in light level and so on. Electronic circuits can be made very much more sensitive than the normal human senses and this circuit has been designed as a very efficient heat alarm, that it will sound off an alarm as soon as either the temperature rises or falls below a certain level. There are several applications for this; it could form the basis of a fire alarm although it could justifiably be claimed that if the temperature rises so far above ambient that an alarm can be triggered, then it will be of little use. However, some commercial fire alarms rely on circuits based on this type of circuit. At the other temperature extreme it can be arranged as a frost warning device in greenhouses or even placed in the loft of a house to warn of possible freezing in the pipes. The cost is not high and even if it only once prevents a tragedy it will repay the investment many times over.

As mentioned, the circuit can be used either to give warning at a high or at a low level and the correct arrangement of VR1 and the thermistor at the input must be used.

A thermistor is a resistor whose value varies with the temperature, normally these have a negative temperature coefficient such as the type used here. At normal temperatures the resistance of TH1 is about 4.7K but when the temperature rises, this falls considerably. It would be possible for this thermistor to be wired into a circuit with only a relay and a battery but this would mean that an appreciable current would have to be passed by the thermistor and it would heat itself up, in any case a high voltage and a sensitive relay would have to be used for such an arrangement.

The thermistor, in conjunction with the variable resistor VR1, forms a potential divider across the supply voltage and it will be seen that the voltage at the base of Tr1 will depend upon the temperature. When the temperature is hot TH1 has a low ohmic value and the transistor will have insufficient voltage at the base for it to conduct. Tr1 and Tr2 are arranged in a Schmitt trigger circuit and this arrangement acts as very rapid and positive electronic switch. As long as the voltage at the base of Tr1 is above a certain level this transistor will be fully switched on and Tr2 will be fully switched off. As soon as the voltage at the base of Tr1 falls below this critical level Tr1 will rapidly switch off, in turn switching on Tr2 meaning that there will be a voltage drop across R3.

The voltage at the collector of Tr2 is arranged to trigger an SCR (also known as a thyristor). When the voltage on the gate approaches that on the anode, the anode and cathode (shown as A and C in the circuit) virtually short out and the supply voltage is applied across the bell.

The bell is the type widely available and has contacts for either a.c. or d.c. (for which a make-and-break circuit is included).

When an SCR is triggered on it will remain on whatever the condition of the voltage at the gate and will only switch off when the supply voltage is removed. Since the make-and-break circuit does precisely this (removes the supply voltage) the bell will only ring while the thermistor is above or below the triggering temperature.

As with all alarm circuits reliability is important and a permanently wired mains operated power supply should be used. The on-off switch is only included so that the bell can be switched off once it has raised the alarm. However, if the alarm is only to be used when danger is possible, e.g. when there is a possibility of frost, a battery may be used as the quiescent current is low - only a few milliamps. If this is used the battery should be of the large layer type such as the PP9.

VR1 acts as the sensitivity control and determines the temperature at which the alarm operates.

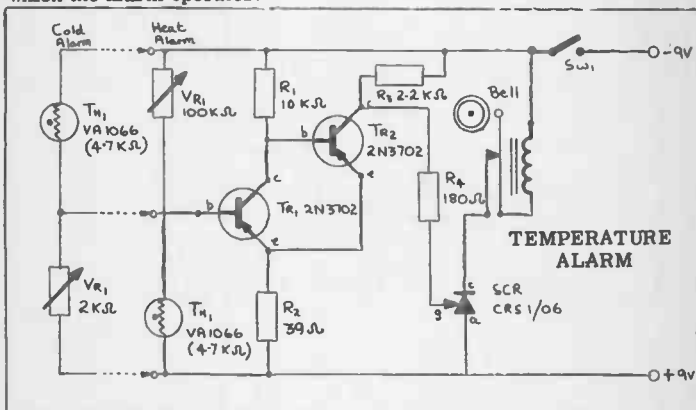

Components List

R1	10K ohms	SCR	CRS1/05, 50V, 1A type.
R2	39 ohms	Bell	See Text
R3	2.2K ohms	SW1	On-off switch
R4	180 ohms		
VR1	100K Lin. Pot. or 2K ohms Lin. Pot.		
TH1	Thermistor type VA1066 or similar - See text		
Tr1	2N3702		
Tr2	2N3702		

SIMPLE ELECTRONIC DOORBELL

It is a relatively simple matter to build an electronic doorbell to replace the more conventional bell. Instead of a ring, an audio frequency note is emitted from a loudspeaker. As well as being novel it is also very easy, using this circuit, to immediately identify whether it is the back or the front door which is calling. The existing wire can be used assuming it takes a conventional form and the electronics can be mounted in a small case in any convenient position.

The circuit is a fairly simple audio oscillator which is in fact a multi-vibrator in a modified form. Only two transistors, one resistor and a capacitor as well as the speaker and its associated transformer are used.

This circuit will work over a wide range of audio frequencies depending mainly on the values of the resistor and the capacitor and the note can be adjusted for personal taste.

The note produced also depends on the voltage supply. The lower the applied voltage, the lower the frequency of oscillation and by using two $4\frac{1}{2}$ V batteries in series we can arrange for either one or both the batteries to be applied to the circuit and this will provide a different note depending on which is applied.

Pretty well any transistors can be used in this circuit as long as TR1 is a PNP type and TR2 an NPN. The output transformer is a miniature output type. These are not widely available for the purpose shown here, though push-pull types that are used in small transistor radios are widely available. These have the primary centre tapped but for our purposes this tap is ignored. The type LT700 is the most widely available at the time of writing but supplies of these types of components vary and completely different types may be used.

Although the output will not be very high in level, it will be perfectly sufficient to draw one's attention but there is a very simple trick which can be used to make the output effectively much greater. If a small diameter speaker is used, these have quite high resonant frequency and if the note, produced by the "bell" that is used most, is selected to coincide with this resonant frequency, the loudness will appear very much greater.

Varying the value of R1 will change the frequency and by changing this the resonant frequency can be found. Speakers with diameters over about 3 in. will not exhibit this effect to any extent as their resonant frequencies are much lower.

The speaker impedance is not at all critical and any with an impedance in the range 3 ohms to 80 ohms can be used, although those with higher impedances will give a slightly reduced output.

Current drain is not important as the circuit is only operational when a button is pushed but in any case it is not high enough to worry the type of batteries that are specified.

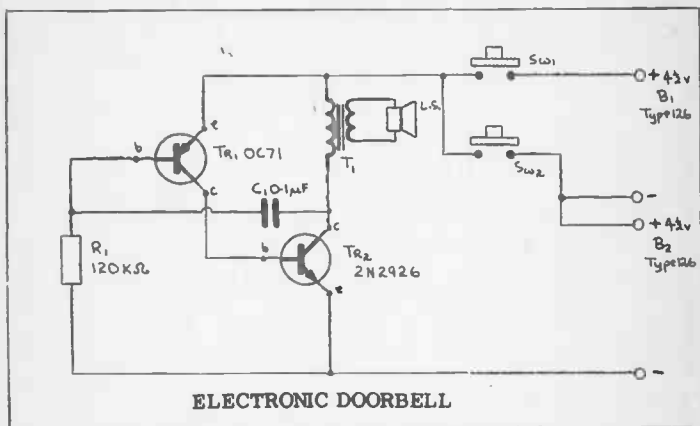

Components List

- R1 120K ohms - See text
- C1 0.1 μ F
- Tr1 OC71
- Tr2 2N2926
- T1 Transistor output transformer - See text
- L.S. Any type, see text
- B1, B2 4½V, Type 126

SIREN

It is possible to simulate a wide variety of everyday sounds electronically, the modern day electronic organ is just one example of this. Parts of circuits can be made to oscillate while others form the "envelope" which controls the amplitude while yet further circuits filter the sounds. Many of these circuits are very complex but some sounds can be reproduced quite simply, such as that of a wailing siren.

The siren produces an audio frequency which rises and falls in pitch at a fixed rate. Sirens vary in their actual sound but the circuit has plenty of room for experimenting to enable the constructors own interpretation to be produced. The sound is applied directly to the loudspeaker with a fairly low level but it is a simple matter to make a small change so that the output can be coupled to an external amplifier for greater output.

The circuit makes use of two oscillators. The first, comprising Tr1 and Tr2 working at a very low frequency, produces a voltage across the load resistor R2. This oscillator controls the rate which the siren repeats itself which is between one and two seconds though the adjustment of VR1 gives much wider control than this. If this is set at two seconds then at that interval, for quite a short time, Tr2 is switched fully on and a voltage, very nearly equal to that of the supply voltage is produced across the load. This is passed on to the second part of the circuit which comprises Tr3 and Tr4. These transistors, with the associated components, form an audio oscillator whose frequency depends both on the setting of VR2 and the applied voltage; the lower the voltage the lower the frequency and vice versa.

When Tr2 is off there is virtually full supply volts at the collector of Tr2 and since this line, in conjunction with the diode forms the negative line of the second oscillator, there is very little voltage for this to produce an output. When the voltage across R2 increases there is sufficient for the audio oscillator to operate and an output is produced. At the same time C4 is charged up. When Tr2 is switched off again the inclusion of the diode prevents the large capacitor C4 from discharging through R2 and this will provide sufficient voltage for the circuit to operate until the next pulse. The voltage across it will fall as the current is drawn to operate the oscillator, this will produce a falling frequency output which is developed in the load provided by the loudspeaker.

This explains how the frequency falls, but how does it rise? When the voltage is applied from the first oscillator it is applied to a partially discharged capacitor and, as this charges, it produces the reverse effect of gradually building the voltage up and so also the frequency. Depending on the components used it may be

found that the rise time is not balanced by the fall time; this can be corrected by inserting a low value resistor in series with the diode. The actual value will have to be found by experiment but will probably lie below 100 ohms. The value of C4 controls the fall time and here again there is room for experiment and it may be found that a value very much lower than that given will be sufficient. The value of R2 also has an effect on the circuit and although values lower than that shown will only reduce the life of the battery, higher values may improve the effect.

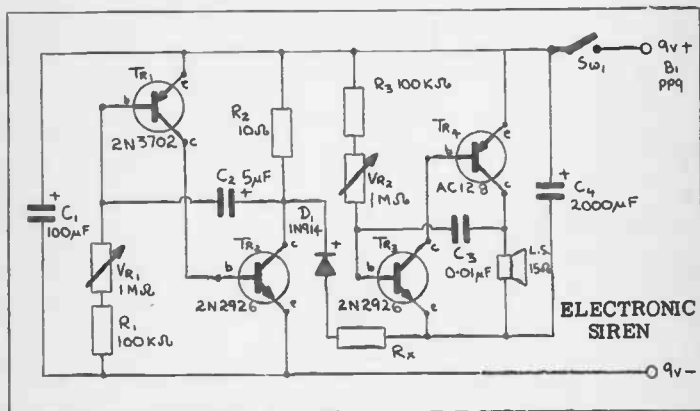

Components List

R1	100K ohms
R2	10 ohms
R3	100K ohms
Rx	See text
VR1	1M ohms linear pot
VR2	1M ohms linear pot
C1	100µF 12V
C2	5µF 12V
C3	0.01µF
C4	2,000µF 12V-See text
Tr1	2N3702
Tr2	2N2926
Tr3	2N2926
Tr4	AC128
D1	1N914
B1	PP9, 9V battery
SW1	On-off switch

SIMPLE AMPLIFIER

The term amplifier covers a very wide range from a one transistor preamp to an ultra sophisticated high power Hi-Fi system. There is no doubt that the latter is much more pleasant to listen to but for many applications high quality is of little importance and simplicity is required. There is little doubt that the circuit shown here is very simple. The output is in the order 250mW - which is quite sufficient for most purposes and is comparable to that of the average transistor radio. The distortion level is rather high but is not high enough to be noticed except by someone with a critical ear, being about 5%. Good frequency response is almost inherent in transistor amplifiers: in fact it is difficult to have a poor response using modern components.

The amplifier is also reasonably sensitive and will give full output with an input of about 50mV. Input impedance is about 50K ohms. A simple tone control is included though as since this is an active control, rather than a passive one, the range is quite sufficient.

The input is applied across the volume control which has R1 in series: as the amplifier is quite sensitive this slight attenuation hardly matters and it does increase the input impedance. For use with a crystal pick-up which has a much higher output and also a higher impedance, this resistor can be increased in value to about 150K ohms.

The slider from the volume control is connected to the base of Tr1 via a d. c. blocking capacitor. Tr1 is connected as a pretty conventional common emitter amplifier with R2 providing the base bias and R3 acting as the collector load. This stage is directly connected to the second transistor which is a PNP type. In this way the current passing through Tr1 provides the bias for the second transistor. Because of the values used, the output of the second transistor is connected directly to the speech coil of the loudspeaker. This is not normally good practice since the standing current in the output transistor continually biases the coil either slightly in or out from its usual operating point. However if a large speaker is used, as it should be, this has very little effect and since we are not aiming at Hi-Fi, it does not matter.

The tone control comprises C2 and VR2 which are connected between the collector and base of Tr1. At high resistance settings of VR2 this has little effect but on minimum settings the 0.1 μ F feeds back the high frequencies out of phase, thus cancelling them.

For this circuit to work properly R3 must be selected with great care. The value shown here of 39 ohms is only a typical one and although it may be used for initial setting up to ensure the circuit is operating, the value should be found by experiment. If it is too low there will be severe distortion at the higher volume settings. If it is too high the current drain will be excessive even though the quality of reproduction will be good.

There are two ways of finding the value. Without a multimeter the value should be selected as being the lowest which is compatible with good quality. If a multimeter is available this should be wired in series with the supply voltage and R3 should be selected so that the quiescent current, this is the current flowing with no input signal, is reading 20mA.

It is very important that Tr2 is fitted with a heatsink as it will get very hot and will probably run away without it.

The speaker impedance is not all that critical and in the prototype speakers with an impedance as low as 8 ohms and as high as 80 ohms all worked well although changing the speaker impedance will also necessitate a change in the value of R3.

For those without a good selection of resistors it may be just as well to replace R3 with a skeleton preset with a value of 100 ohms, this should certainly cover any likely resistance which is the optimum for the particular circuit.

As we have said, current drain with this circuit is quite heavy for, although it is reasonably efficient, you cannot get a high output without using a reasonably high current.

This amplifier will accept a wide variety of inputs and will be found to be very useful for adding to many types of electronic circuits.

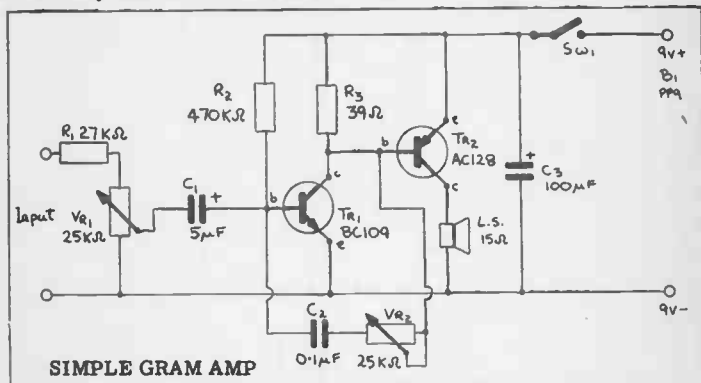

Components List		VR1	25K ohms log. pot. with switch
R1	27K ohms - See text	VR2	25K ohms lin. pot.
R2	470K ohms	C1	5 μ F 12V
R3	39 ohms - See text	C2	0.1 μ F
		C3	100 μ F 12V
		Tr1	BC109
		Tr2	AC128
		Battery 9V, PP9	

VEROBOARD DATA

Drilled Printed Circuit Board with Copper Strips.

Veroboard is available in 3 sizes of hole spacing i. e. .1", .15" and .2" matrix.

We list here the most popular sizes normally stocked by the better type of Radio Component dealer.

Type No.	Size		Holes	Matrix hole Spacing
	Width	x Length		
14354/P16	2 $\frac{1}{2}$ "	x 1"	24 way x 10 deep	.1"
10346	2 $\frac{1}{2}$ "	x 3 $\frac{3}{4}$ "	24 way x 36 deep	.1"
10345	2 $\frac{1}{2}$ "	x 5"	24 way x 48 deep	.1"
13236	2 $\frac{1}{2}$ "	x 17"	24 way x 170 deep	.1"
10348	3 $\frac{3}{4}$ "	x 3 $\frac{3}{4}$ "	36 way x 36 deep	.1"
10347	3 $\frac{3}{4}$ "	x 5"	36 way x 48 deep	.1"
13237	3 $\frac{3}{4}$ "	x 17"	36 way x 170 deep	.1"
126/P16	4.7"	x 17.9"	38 way x 180 deep	.1"
14353/P16	2 $\frac{1}{2}$ "	x 1"	16 way x 7 deep	.15"
43P16	2 $\frac{1}{2}$ "	x 3 $\frac{3}{4}$ "	16 way x 24 deep	.15"
42P16	2 $\frac{1}{2}$ "	x 5"	16 way x 32 deep	.15"
41P16	2 $\frac{1}{2}$ "	x 17"	16 way x 113 deep	.15"
46P16	3 $\frac{3}{4}$ "	x 3 $\frac{3}{4}$ "	24 way x 24 deep	.15"
45P16	3 $\frac{3}{4}$ "	x 5"	24 way x 32 deep	.15"
44P16	3 $\frac{3}{4}$ "	x 17"	24 way x 113 deep	.15"
4/1001/P16	4.8"	x 18"	21 way x 91 deep	.2"

PLAIN VEROBOARD - DRILLED UNCOPPERED

PLAIN	11990	2 $\frac{1}{2}$ " x 5"	.15 Matrix
	11991	2 $\frac{1}{2}$ " x 3 $\frac{3}{4}$ "	.15 Matrix
	441/4501	17" x 2 $\frac{1}{2}$ "	.15 Matrix
	442/4505	17" x 3 $\frac{3}{4}$ "	.15 Matrix
	442/8023	17" x 5"	.15 Matrix
	14352	5" x 3.75"	.15 Matrix
	522	3.75" x 17.9"	.1 Matrix

VEROPACK Retail Pack of 5 sample pieces of Veroboard with spot face cutter

D. I. P. BREADBOARD 13401 4.15" x 6.15"

GROUP BOARD 11986 53 Way Group Board 8 $\frac{1}{2}$ "x1 $\frac{1}{2}$ " .15 Matrix

ACCESSORIES	2022	Spot Face Cutter
	2150	Pin Insertion Tool for 2140 Pins
	2151	Pin Insertion Tool for 2144 Pins
	2140	Vero Pins .15 Matrix in Packets of 36
	2141	Vero Pins .15 Matrix in Packets of 36
	2144	Vero Pins .1 Matrix in Packets of 36
	2140	Vero Pins .15 Matrix in Packets of 1000
2144	Vero Pins .1 Matrix in Packets of 1000	

EDGE CONNECTORS	24 way	Edge Connector .1 Matrix
	36 way	Edge Connector .1 Matrix
	16 way	Edge Connector .15 Matrix
	24 way	Edge Connector .15 Matrix

FIRST BOOK OF TRANSISTOR EQUIVALENT AND SUBSTITUTES

**HIGH GRADE
SQUARE BACK
BINDING**

**80 PAGES
BY
B. B. BABANI**

**I.S.B.N.
0 85934 000 7**

Since its publication, The First Book of Transistor Equivalents has had to be reprinted 10 times, reaching world sales exceeding 1,000,000 copies. The First Book is produced in the same style as the Second Book but in no way duplicates any of the data presented in this book. The First Book contains different data and the two books complement each other and make available the most complete and extensive information in this field. The unique features have been used in both books making for very easy use by amateurs, engineers and industrial users. The interchangeability data covers semiconductors manufactured in Gt. Britain, U.S.A., Germany, France, Poland, Italy, Czechoslovakia, Japan, Australia, Scandinavia, Switzerland, East Germany, Belgium, Austria, Netherlands and many other countries. Immediate equivalents are shown and possible substitutes are also included.

We have shown, as in the Second Book, all the CV listings allotted to every type of transistor.

TANDY BOOK NO. 62-9001

PRICE 40p

TANDY RADIO BOOKS

62-9001	First Book of Transistor Equivalents and Substitutes	40p
62-9002	Handbook of Radio, TV, Industrial and Transmitting Tube and Valve Equivalents	60p
62-9003	Worlds Short, Medium and Long Wave FM and TV Broadcasting Stations Listing – International Edition	60p
62-9004	Radio and Electronic Colour Codes and Data Chart	15p
62-9005	Practical Transistor Novelty Circuits	40p
62-9006	Electronic Novelties for the Motorist	50p
62-9007	Second Book of Transistor Equivalents and Substitutes	95p
62-9008	Constructors Manual of Electronic Circuits for the Home	50p
62-9009	Handbook of Electronic Circuits for the Amateur Photographer	60p
62-9010	Radio Receiver Construction Handbook using IC's and Transistors	60p
62-9011	Boys and Beginners Book of Practical Radio and Electronics	60p
62-9012	The Boys Book of Crystal Sets	25p
62-9013	Coil Design and Construction Manual	50p
62-9014	Radio, TV and Electronics Data Book	60p
62-9015	Handbook of Practical Electronic Musical Novelties	50p
62-9016	Handbook of Integrated Circuits (IC's) Equivalents and Substitutes	75p
62-9017	IC's and Transistor Gadgets Construction Handbook	60p
62-9018	Second Book of Hi-Fi Loudspeaker Enclosures	60p
62-9019	First Book of Hi-Fi Loudspeaker Enclosures	60p
62-9020	Practical Transistor Circuits for Modern Test Equipment	60p