

No. 170-2

basic electronics

by **VAN VALKENBURGH,
NOOGER & NEVILLE, INC.**

VOL. 2

INTRODUCTION TO AMPLIFIERS
THE TRIODE TUBE
TETRODES & PENTODES
AUDIO VOLTAGE &
POWER AMPLIFIERS

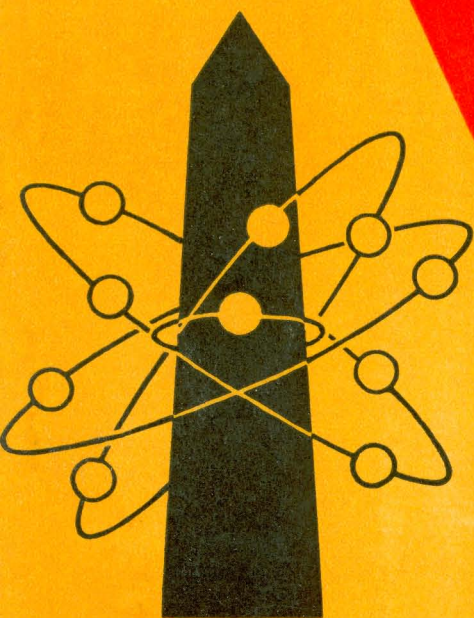

A. STICH

a **RIDER** publication

\$2.25

basic electronics

**by VAN VALKENBURGH,
NOOGER & NEVILLE, INC.**

VOL. 2



JOHN F. RIDER PUBLISHER, INC.
116 West 14th Street • New York 11, N. Y.

First Edition

Copyright 1955 by

VAN VALKENBURGH, NOOGER AND NEVILLE, INC.

All Rights Reserved under International and Pan American Conventions. This book or parts thereof may not be reproduced in any form or in any language without permission of the copyright owner.

Library of Congress Catalog Card No. 55-6984

Printed in the United States of America

PREFACE

The texts of the entire Basic Electricity and Basic Electronics courses, as currently taught at Navy specialty schools, have now been released by the Navy for civilian use. This educational program has been an unqualified success. Since April, 1953, when it was first installed, over 25,000 Navy trainees have benefited by this instruction and the results have been outstanding.

The unique simplification of an ordinarily complex subject, the exceptional clarity of illustrations and text, and the plan of presenting one basic concept at a time, without involving complicated mathematics, all combine in making this course a better and quicker way to teach and learn basic electricity and electronics.

In releasing this material to the general public, the Navy hopes to provide the means for creating a nation-wide pool of pre-trained technicians, upon whom the Armed Forces could call in time of national emergency, without the need for precious weeks and months of schooling.

Perhaps of greater importance is the Navy's hope that through the release of this course, a direct contribution will be made toward increasing the technical knowledge of men and women throughout the country, as a step in making and keeping America strong.

Van Valkenburgh, Nooger and Neville, Inc.

New York, N. Y.

February, 1955

TABLE OF CONTENTS

VOL. 2 — BASIC ELECTRONICS

Introduction to Amplifiers	2-1
The Triode	2-11
The Triode Amplifier	2-24
The Tetrode and the Pentode	2-42
The Single-Stage Amplifier	2-55
The Two-Stage RC Coupled Amplifier	2-58
The Transformer-Coupled Amplifier	2-67
The Audio Power Amplifier	2-71
The Output Transformer	2-74
The Push-Pull Amplifier	2-78
Microphones, Earphones and Loudspeakers	2-87

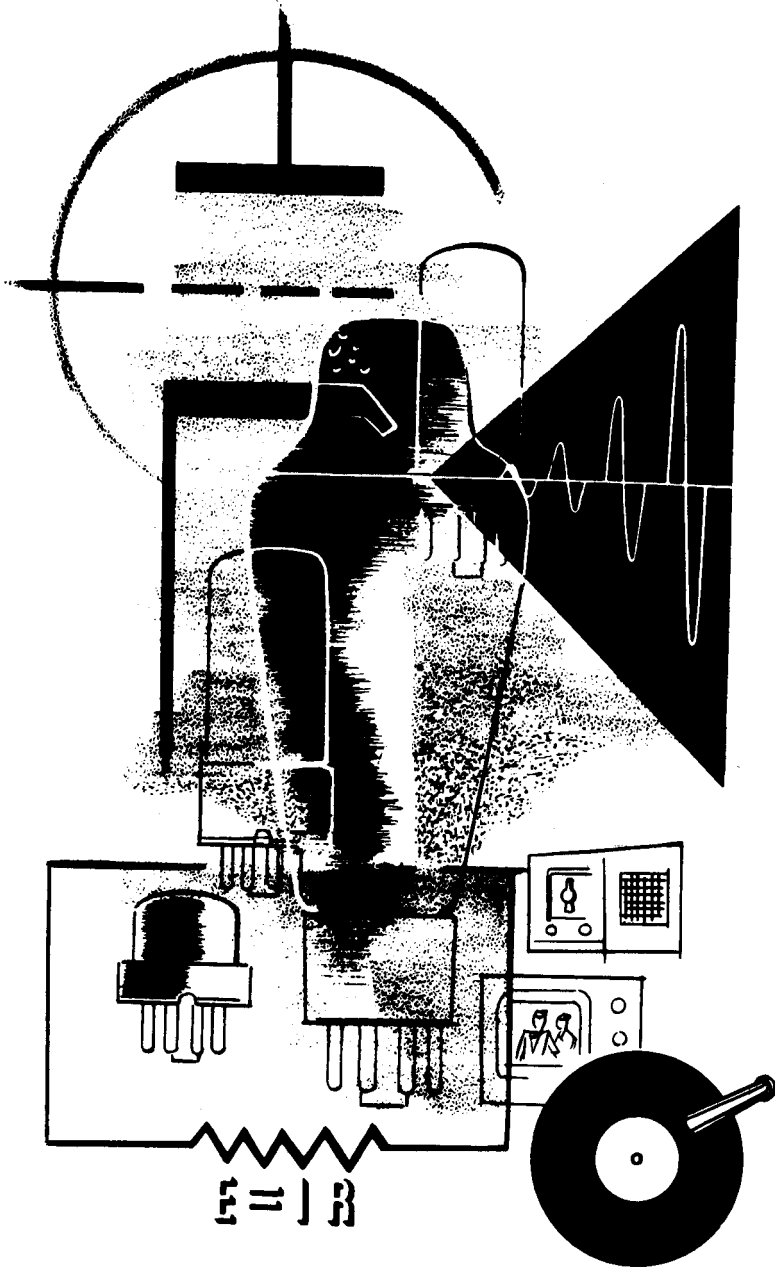

$$E = IR$$

Audio Amplifiers

INTRODUCTION TO AMPLIFIERS

Examples of Amplification

There are many things you can amplify:



Fact

Examples of Amplification (continued)

Sight

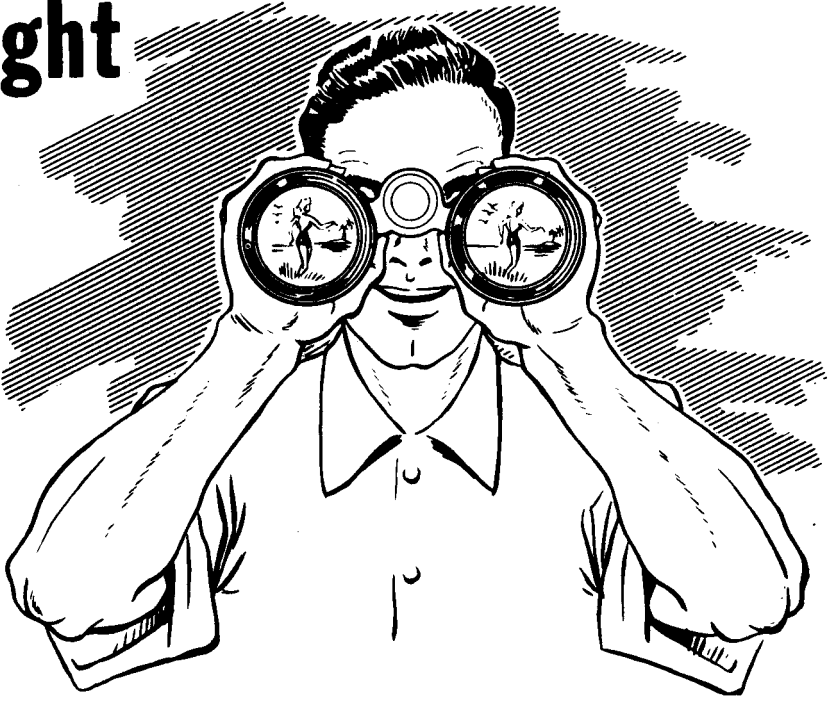

Sound



INTRODUCTION TO AMPLIFIERS

Examples of Amplification (continued)

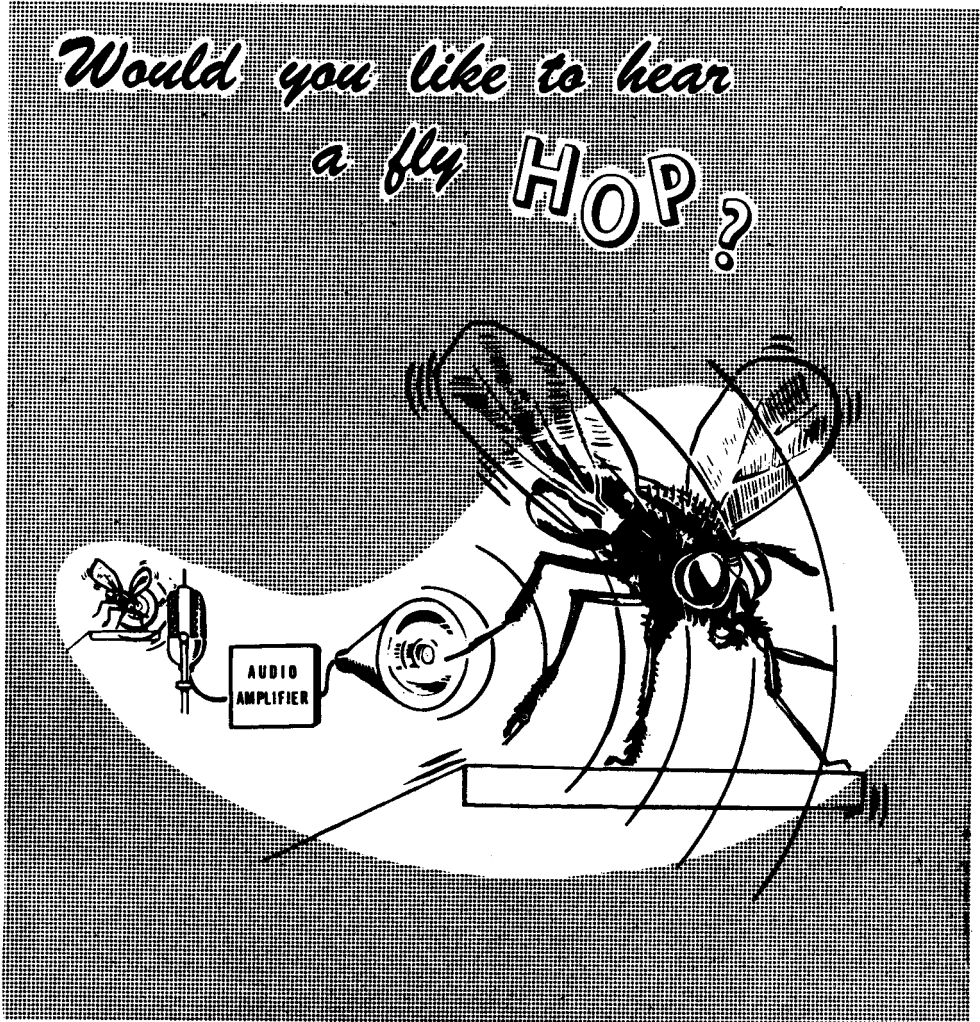

would you like to hear a whisper through a concrete wall or hear a fish pump water through its gills? Amplification makes all these things possible. There are however, more important uses for amplifiers.

Of the three basic types of electronic circuits—rectifiers, amplifiers and oscillators—amplifiers are by far the most widely used. The purpose of an amplifier is to take a very small voltage change—one that is so small that it cannot be used—and amplify it many times so that it can run a pair of earphones, drive a loudspeaker, be seen on a 'scope, operate a motor, etc.

INTRODUCTION TO AMPLIFIERS

What a Vacuum Tube Can Do

Make a Radio Play

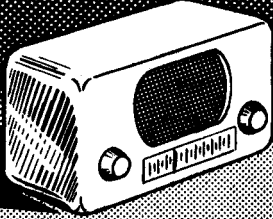

Show You Your Favorite
Television Program

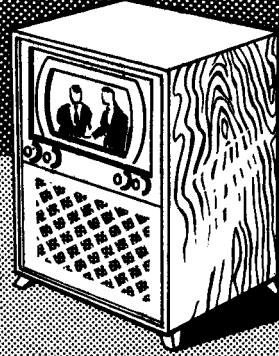

*I can do all
these things*

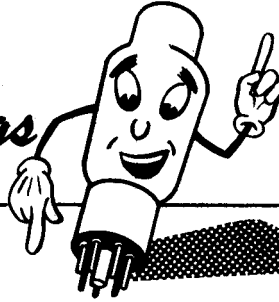

Operate A Radar System Which Seeks Out Enemy Planes

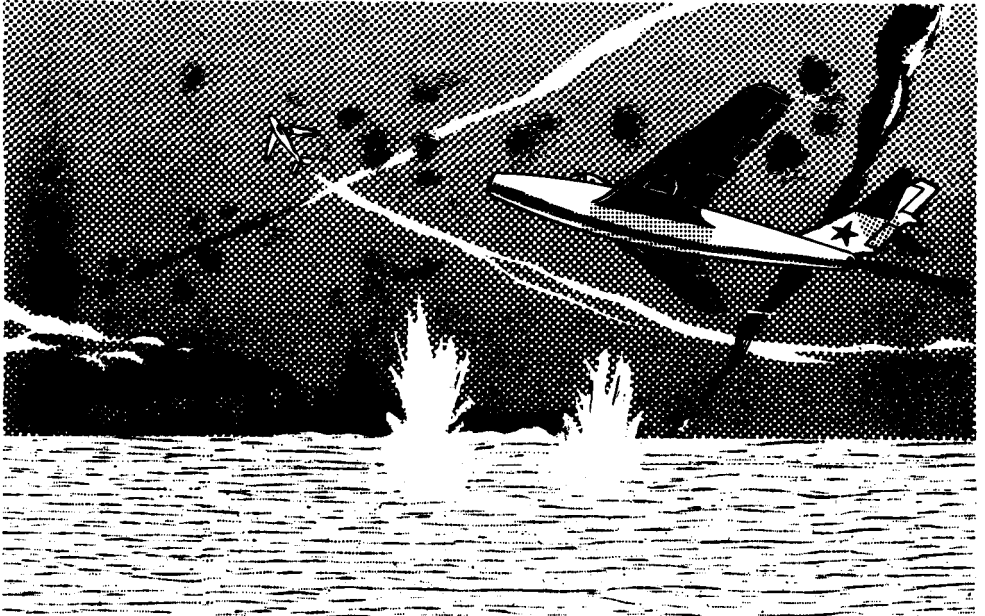

INTRODUCTION TO AMPLIFIERS

What a Vacuum Tube Can Do (continued)

When you first began your study of vacuum tubes you learned that there are only two main jobs for vacuum tubes to do.

The first job is to change an AC voltage into a pulsating DC voltage. This is called "rectification."

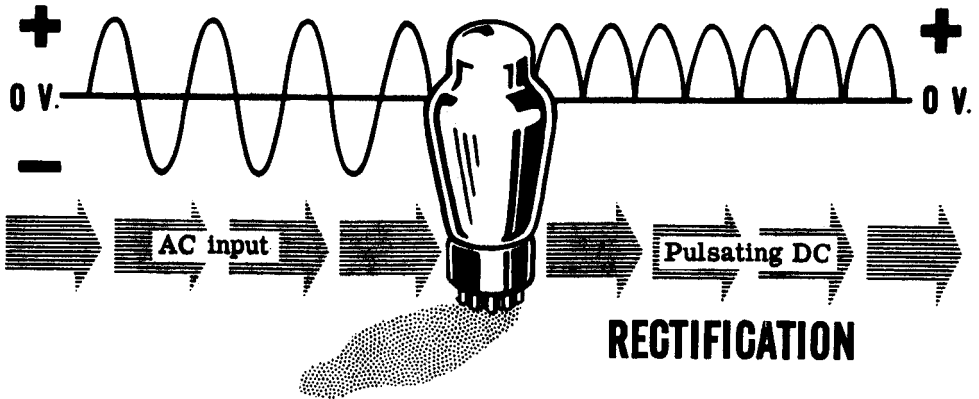

The second job is to change a small AC voltage into a large AC voltage. This is called "amplification."

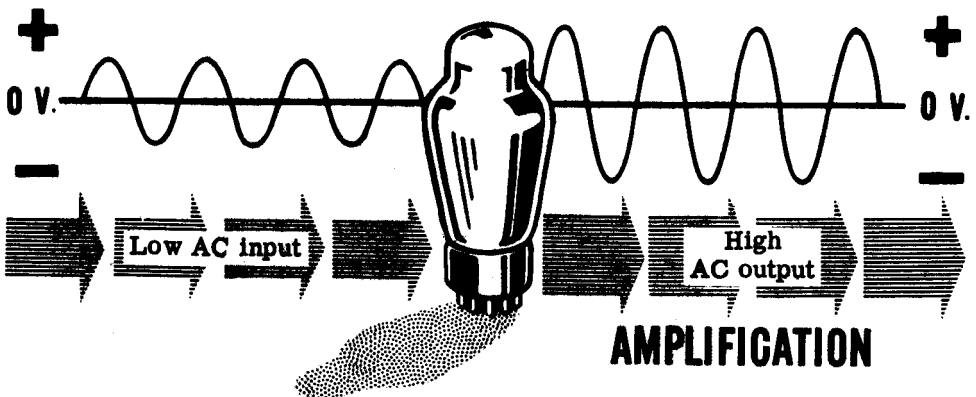

Because of your work with rectifier and power supply circuits, you now know all you need to know about rectification and the diode tubes that are used to do this job. Now you are ready to learn about the second main job a vacuum tube can do—amplification. In this section you will learn about the vacuum tubes that do the job of amplifying small AC voltages into large AC voltages.

INTRODUCTION TO AMPLIFIERS

Types of Vacuum Tubes

A recent survey of vacuum tubes manufactured in the United States showed that there are over 1,200 different types of vacuum tubes available! These tubes come in a wide variety of shapes and sizes—enclosed in glass and metal shells.

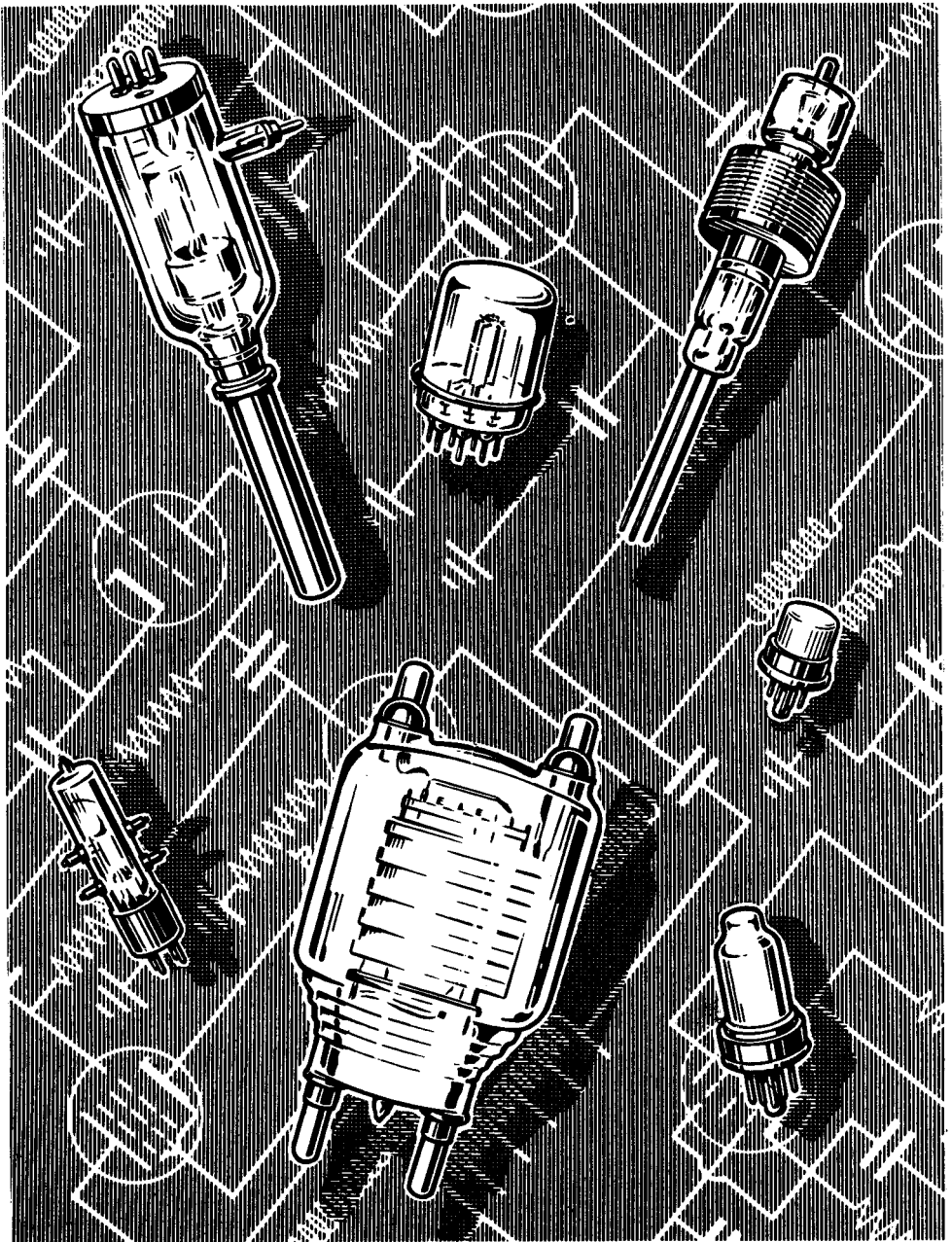

INTRODUCTION TO AMPLIFIERS

Types of Vacuum Tubes (continued)

Most of these 1,200 tubes can be broken down into four main types. Once you understand these four main types, you will know them all. Whenever you run across a new tube, you will always be able to understand what it does and how it works simply by comparing it to the four main types you know.

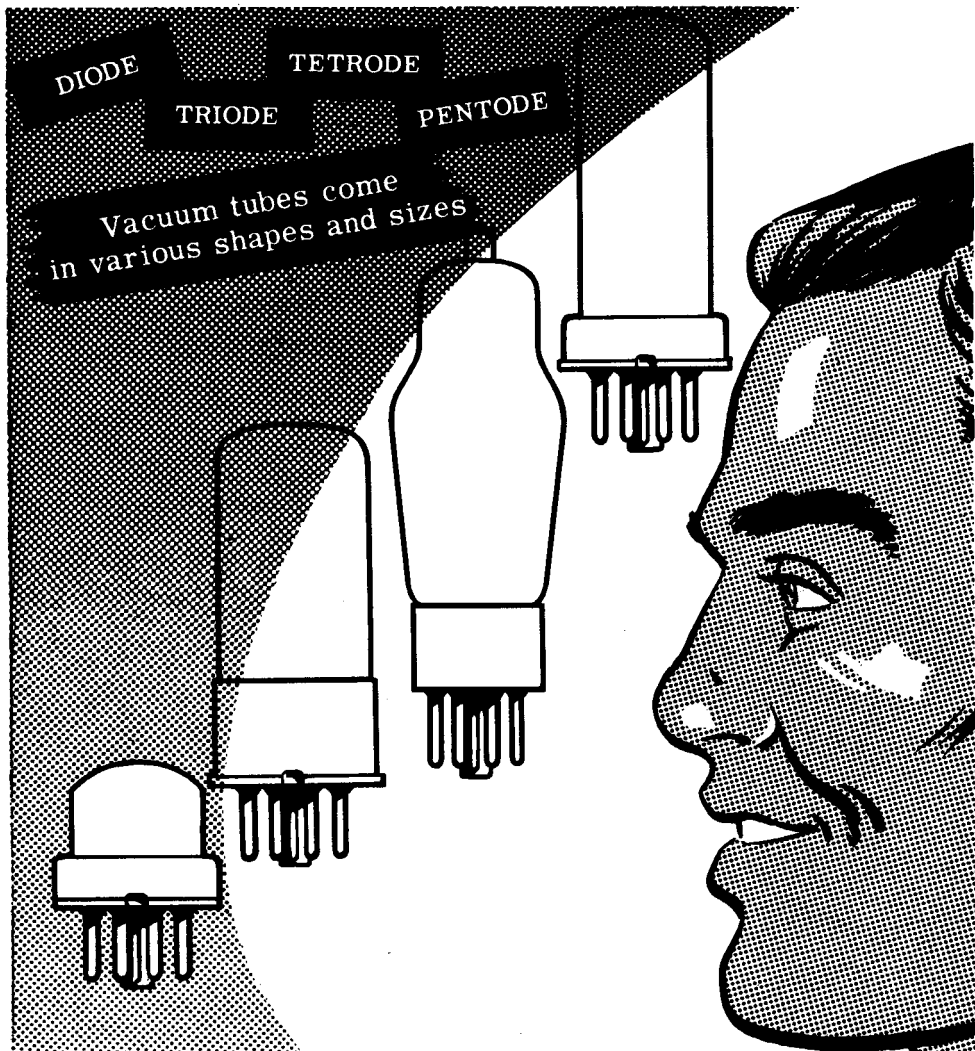

Their names describe them by telling how many parts (cathode, grid, plate) there are in the tube. A diode (di = two) has two parts—a cathode and a plate. A triode (tri = three) has three parts—a cathode, a plate and one grid. A tetrode (tetra = four) has four parts—a cathode, a plate and two grids. A pentode (penta = five) has five parts—a cathode, a plate and three grids.

How Vacuum Tubes Were Developed

Development of Vacuum Tubes

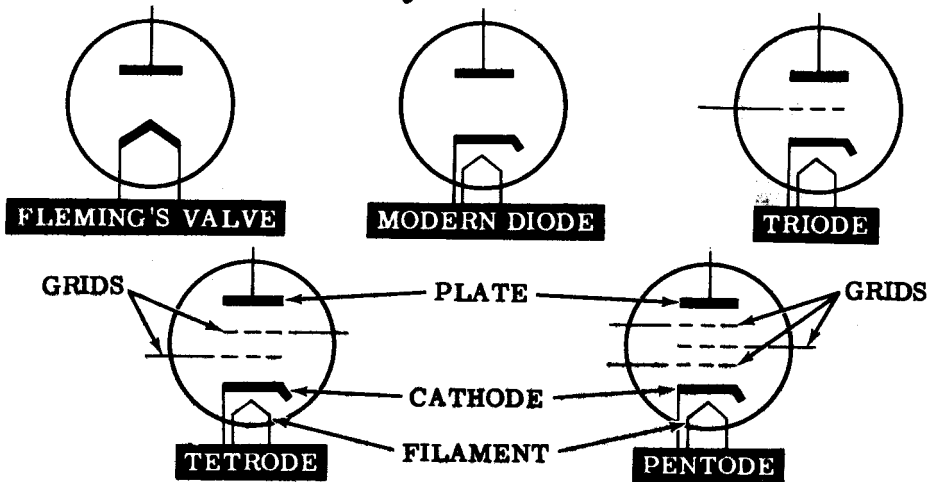

Tubes have developed in a logical sequence. . .

1. from Fleming's valve which consists of two elements, the filament and the plate,
2. to the modern diode in which the filament is replaced by a combination of a filament and a cathode (for reasons which will be discussed later) but which is still considered to be a two-element tube,
3. to the triode a three-element tube which contains one grid,
4. to the tetrode a four-element tube with two grids,
5. to the pentode a five-element tube with three grids.

The reason you are being taught vacuum tubes is not so that you will be able to repair one which has gone bad; you will only replace such a tube with a new one. You are being taught about these vacuum tubes in order to understand the circuits which use them and, thereby, to make you a more valuable troubleshooter of electronic equipment.

You will remember from your work with power supplies that thermionic emission—the emitting of electrons by a hot cathode—allowed you to change AC into DC. Notice that triodes, tetrodes and pentodes also contain a cathode, which emits electrons, and a plate which collects electrons. As you study these tubes you will see how the grids control electron flow to change small AC voltages into large AC voltages.

INTRODUCTION TO AMPLIFIERS

How Vacuum Tubes Were Developed (continued)

The construction of each of these four types varies greatly—all diodes, for example, are not built the same, do not look alike and do different jobs. In addition, combinations of a diode, triode, or pentode, may be put in one tube envelope. All these combinations add up to the 1,200 vacuum tubes manufactured today.

THE FOUR MAIN TYPES

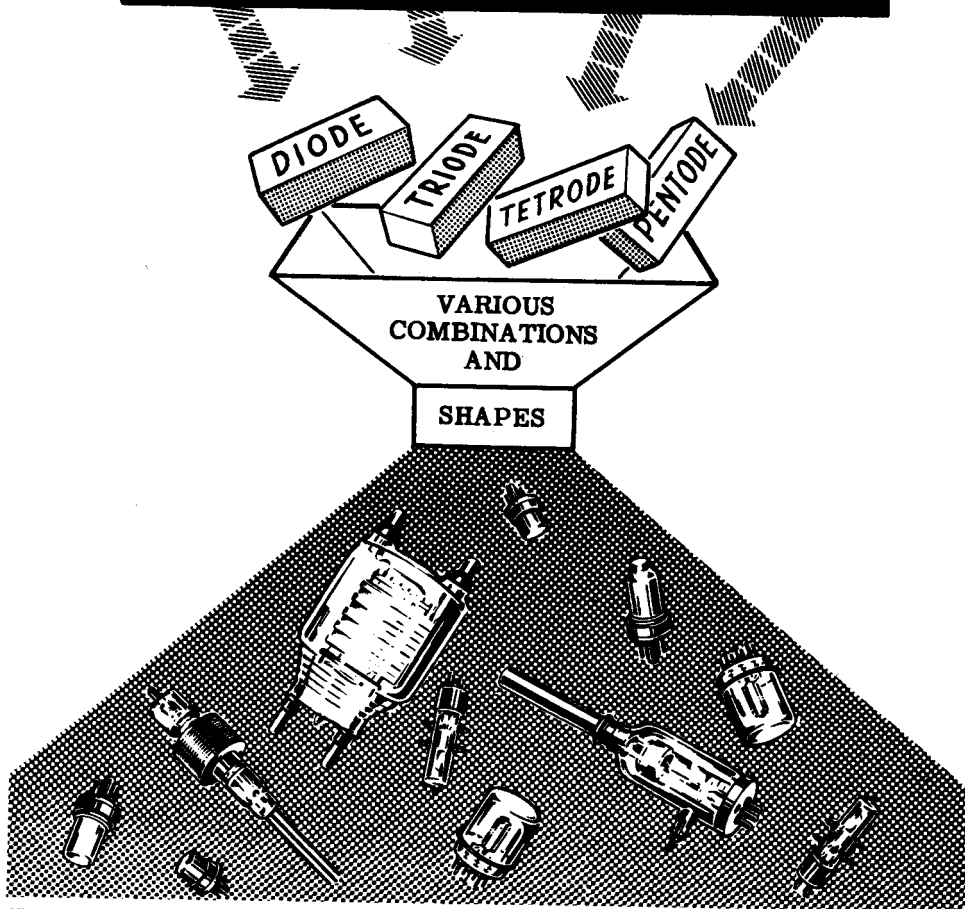

Every electronic circuit has its particular needs, and there is a vacuum tube for every job. Some have to handle small amounts of power, others large amounts. Sometimes they must work with low frequency currents, sometimes high frequencies and sometimes ultra-high frequencies. Sometimes they must be made small enough so that they can fit in a hearing aid or in the fuse container of a high explosive shell. They must be heated by 1 volt, by 2 volts, or sometimes by 6 volts, etc., etc. Sometimes because of limited space available, a diode and a triode must share the same shell. Sometimes two diodes and a triode or a diode, a triode and a pentode must share the same shell!

INTRODUCTION TO AMPLIFIERS

Types of Amplifiers

Amplifiers are designed to amplify only those frequencies their type of equipment requires and can be divided into three general groups according to the frequency range of the signals they amplify.

- 1. Audio Amplifiers:** These amplify a band of frequencies from 15 cycles per second (cps) to 15,000 cps. This is the range of frequencies which the ear can hear—therefore the name "audio." These amplifiers produce a great deal of the amplification in radio receivers, in intercom equipment, in sonar and in many other types of equipment.
- 2. Video Amplifiers:** These are similar to audio amplifiers in that they cover a wide range or band of frequencies and are also similar in design and operation. The frequency band, however, is very much expanded, covering frequencies from 30 cps to 6,000,000 cps and higher. Video amplifiers are used primarily to amplify signals for 'scope presentations in radar and fire control equipment and in television.
- 3. Radio Frequency Amplifiers:** Unlike the other types, RF amplifiers amplify a narrow band of frequencies, but this narrow band may be anywhere within the wide range of frequencies from 30,000 cps to several billions of cycles per second. They are used in radar, fire control, sonar, radio receivers and transmitters. When you tune a piece of equipment, such as a home receiver, you are changing the narrow band of frequencies which the set will amplify.

AUDIO AMPLIFIERS IN	VIDEO AMPLIFIERS IN	R. F. AMPLIFIERS IN
<ul style="list-style-type: none">● RADIO RECEIVERS● INTERCOM EQUIPMENT● SONAR	<ul style="list-style-type: none">● TELEVISION● RADAR● SONAR● FIRE CONTROL GEAR	<ul style="list-style-type: none">● RADAR ● SONAR● FIRE CONTROL GEAR● RADIO RECEIVERS● TRANSMITTERS

Even though they may look different from one another, amplifiers all work in much the same way. In the following work you will learn the operation of audio amplifiers. They come first because they are the simplest of the three and they will help you to understand how the others work.

THE TRIODE

Vacuum Tubes and Amplification

One of the most important applications of vacuum tubes is their use to change a small voltage input into a large voltage output. This process of increasing voltages is called amplification.

For example, in an ordinary radio set the tubes take a signal of a few millionths of a volt from the antenna ("aerial") and change it into a powerful signal that is capable of driving a loudspeaker. This requires a great deal of amplification.

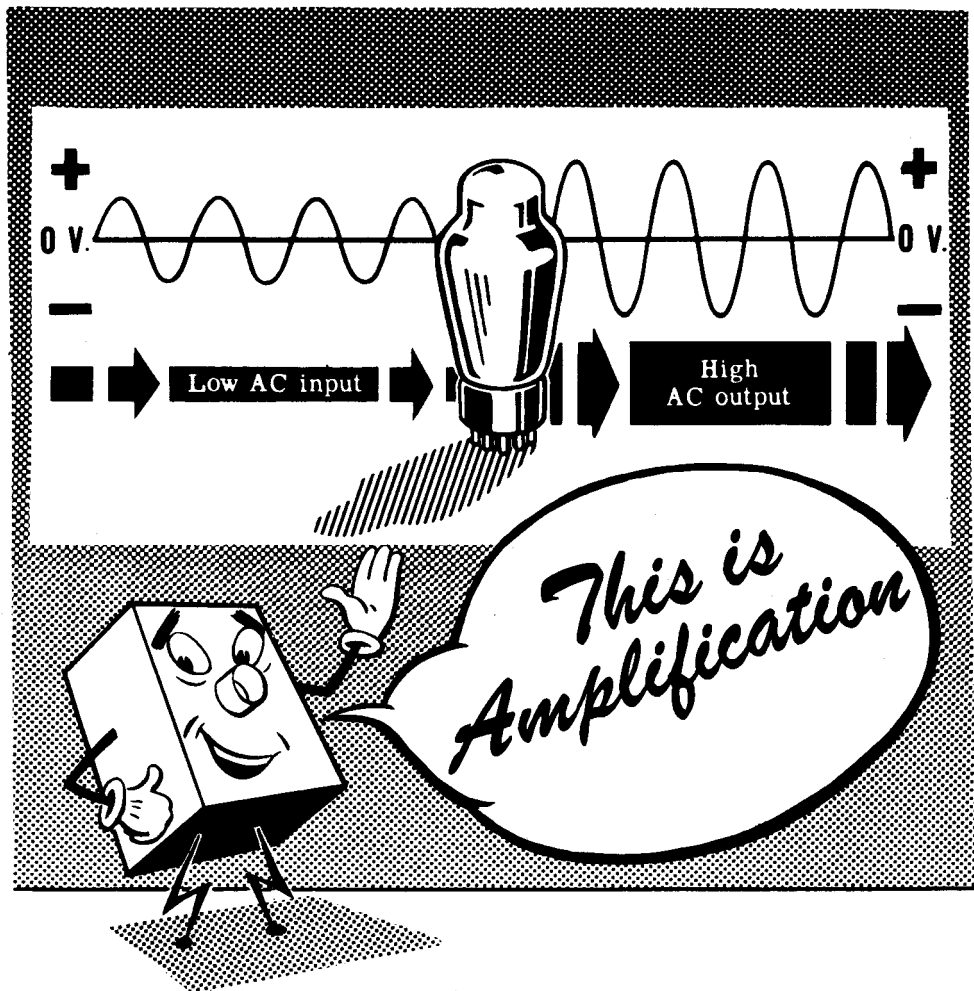

You will find that vacuum tubes are used to produce amplification in receivers, in transmitters, in sonar, in radar and in loran; and it is a foregone conclusion that when new types of electronic equipment come into use, some of the tubes there, too, will be used for amplification.

One of the tubes which can produce amplification is the triode.

THE TRIODE

A Typical Triode Tube

THE CONSTRUCTION OF A TYPICAL *Triode Tube*

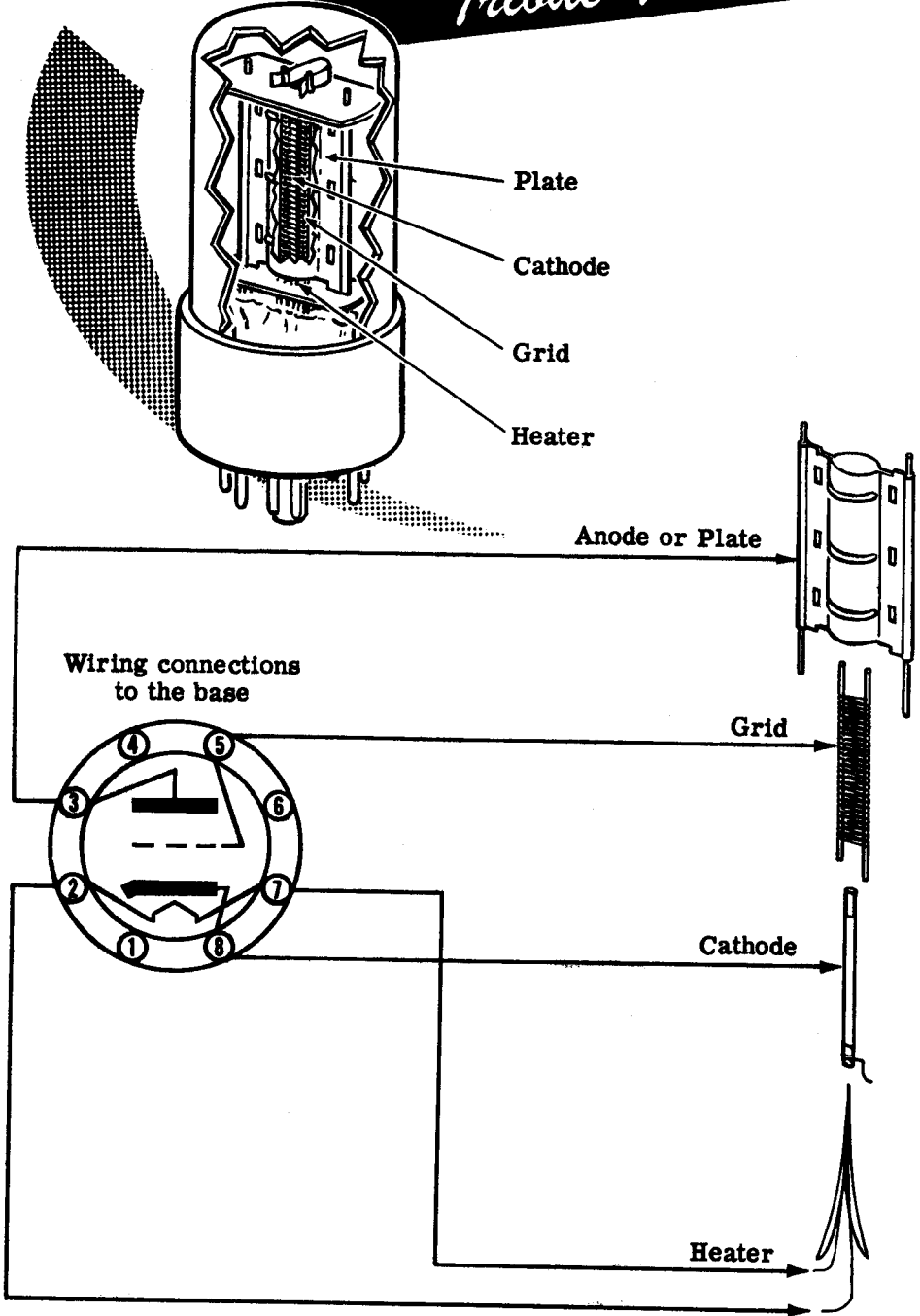

THE TRIODE

Seeing How the Triode Works

For purposes of explanation, let's compare the triode to the water system shown below. In the water system, you are interested in controlling the flow of water. One way you can do this is by varying the pressure in the system or, in other words, changing the height of the water tank.

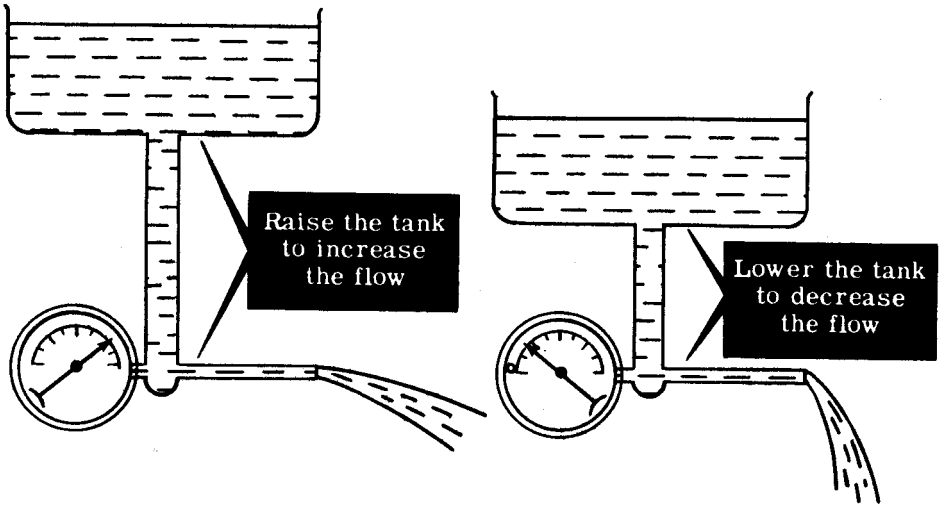

A much more convenient way to vary the flow of water is by using a faucet or valve in the system. Then, by simply turning the faucet, you can control the flow of water. Notice that the water pressure doesn't have to change in order to affect the flow.

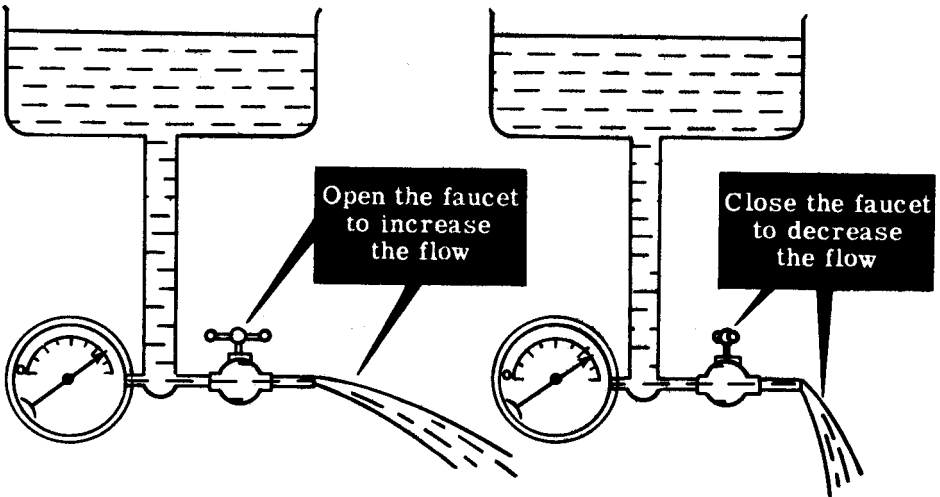

This is similar to the way a triode tube amplifies the flow of current. In the triode an additional element, the grid, is placed in the tube, its purpose being to control the flow of current in the tube just as the faucet controls the flow of water. You will see that a small voltage variation on this element produces a comparatively large current variation in the tube.

THE TRIODE

The Control Grid

This additional structure in the triode is called a "grid" or, more specifically, (to distinguish it from other grids found in tetrodes, pentodes, etc.) the "control grid". It is a very thin wire wound like a spiral around the cathode so that tube current can pass right through its spacings.

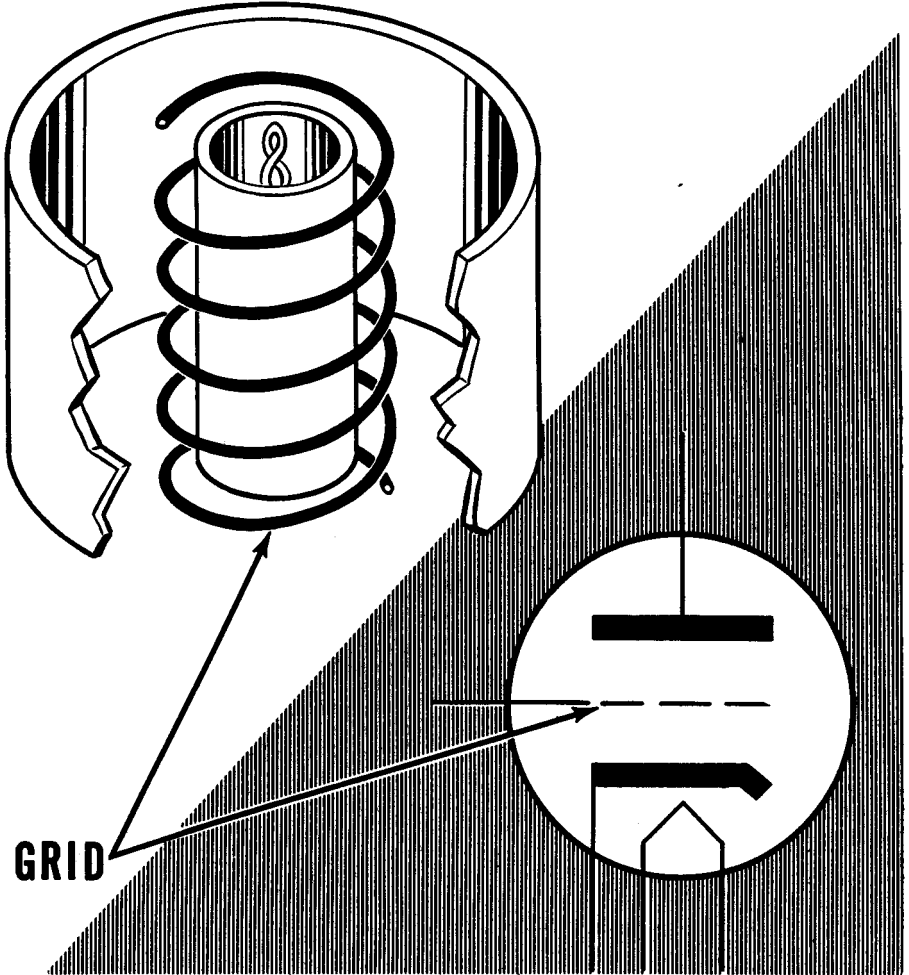

The plate of a triode is normally connected to a high positive voltage, $B+$. The grid of the triode is usually kept at a negative voltage with respect to the cathode. Because electrons are negatively charged, they tend to be repelled by the negative grid. The grid, being closer to the cathode than is the plate, has a greater effect in controlling the tube current than does the positive plate. If the grid becomes less negative, more electrons will get through to the plate; if the grid becomes more negative, fewer electrons will get through to the plate.

THE TRIODE

The Control Grid (continued)

This is what happens when you vary the DC voltage (called "bias") on the control grid. The plate is very positive and tends to attract electrons. If the grid is negative, it tends to repel electrons.

Cut-off

When the grid is made sufficiently negative, its tendency to hold back the electrons will just equal the plate's pull on the electrons and no current will flow. The point at which the two effects are balanced is called "cut-off." When the grid is more negative than this, the tube is operating "beyond cut-off" and no current flows.

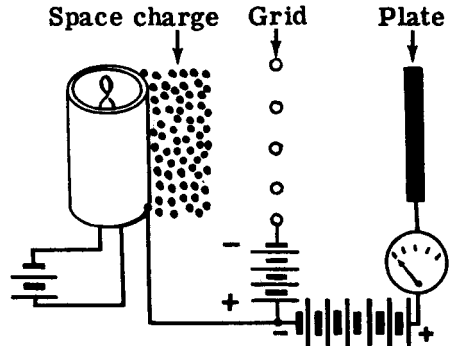

Less than cut-off

When the negative charge on the grid is reduced, a few electrons manage to get from the space charge to the plate.

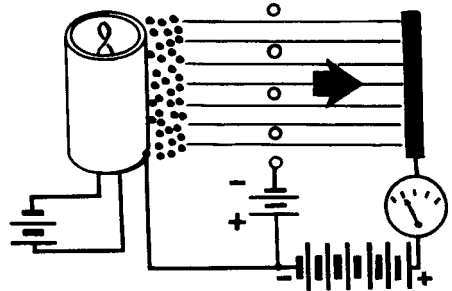

Much less than cut-off

When the grid voltage is reduced further or made equal to zero, more current will flow from the space charge to the plate.

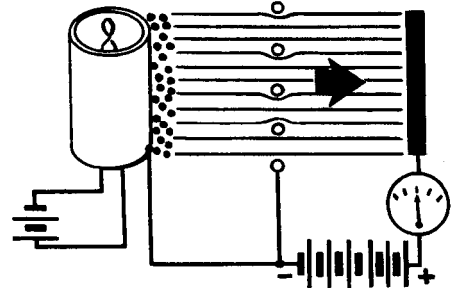

Saturation

If the grid is made positive with respect to the cathode, still more current will flow. A point will be reached when the grid is so positive that the electrons flow from the cathode as fast as the cathode can emit them. This is saturation and a still further increase in grid voltage will not cause an increased current to flow.

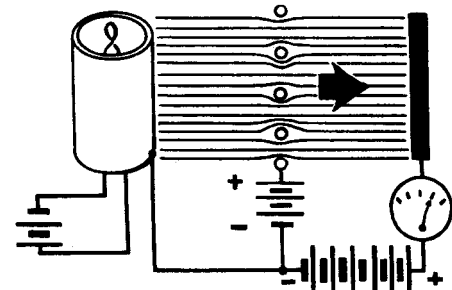

THE TRIODE

How the Triode Is Similar to the Diode

Since the only difference between the two tubes is the presence of a grid, you might expect to find several similarities between them.

The triode's cathode and filament are no different than the diode's and, therefore, everything that was said about a diode's electron emission is also true of the triode's. In both tubes the emission (and therefore saturation) depends upon the filament voltage. In both, burned-out filaments are the most common cause of failure and, in both, cathode emission will decrease as a tube is used.

DIODE...

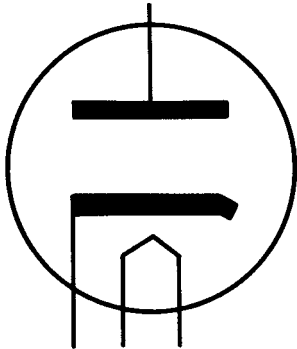

*plus a grid
equals...*

TRIODE

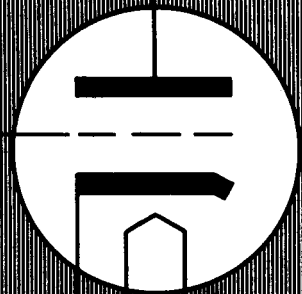

As in the diode, saturation in a triode occurs because there is a limit to the amount of current which the cathode can emit. In the triode, saturation (limiting current) can be reached at a lower value of plate voltage if a positive voltage is applied to the grid; in the diode, of course, it depends only on the plate voltage.

On the other hand, if the grid is made sufficiently negative, no current will flow. The value of grid voltage which reduces the current to zero is called the "cut-off" voltage. Increasing the negative grid voltage beyond this point will have no effect since the tube is already cut off. Cut-off also depends upon the triode's plate voltage; with a more positive plate voltage, a more negative grid voltage will be necessary to produce cut-off.

In a diode current flows only when the plate is positive, and no current flows when the plate is negative. In a triode, however, the plate can be positive and still no current flows if the grid is sufficiently negative. The cut-off point of a triode depends upon the particular tube (how it is constructed) and upon the value of plate voltage.

THE TRIODE

How Amplifiers Work

You have found out a little about how important amplifier circuits are in equipment. Now you are ready to find out how they work.

It's all very simple—a vacuum tube does the entire job of amplifying if you provide it with the proper operating voltages and connections. If you supply the proper voltages to the various tube elements, a small change in voltage applied to the grid causes a large change in voltage on the plate. The production of a large voltage change from a small voltage change is called "amplification."

You learned that a good way for you to picture the operation of a grid in a vacuum tube was to think of the grid as a valve in a water pipe. The British are so fond of this explanation that, to this day, they call a vacuum tube a "valve." When the grid of the tube is very negative, the "valve" is closed and there is little or no flow of electrons from the cathode to the plate. When the grid voltage is changed so that it becomes only slightly negative, the "valve" is nearly wide open and there is a large flow of electrons from the cathode to the plate.

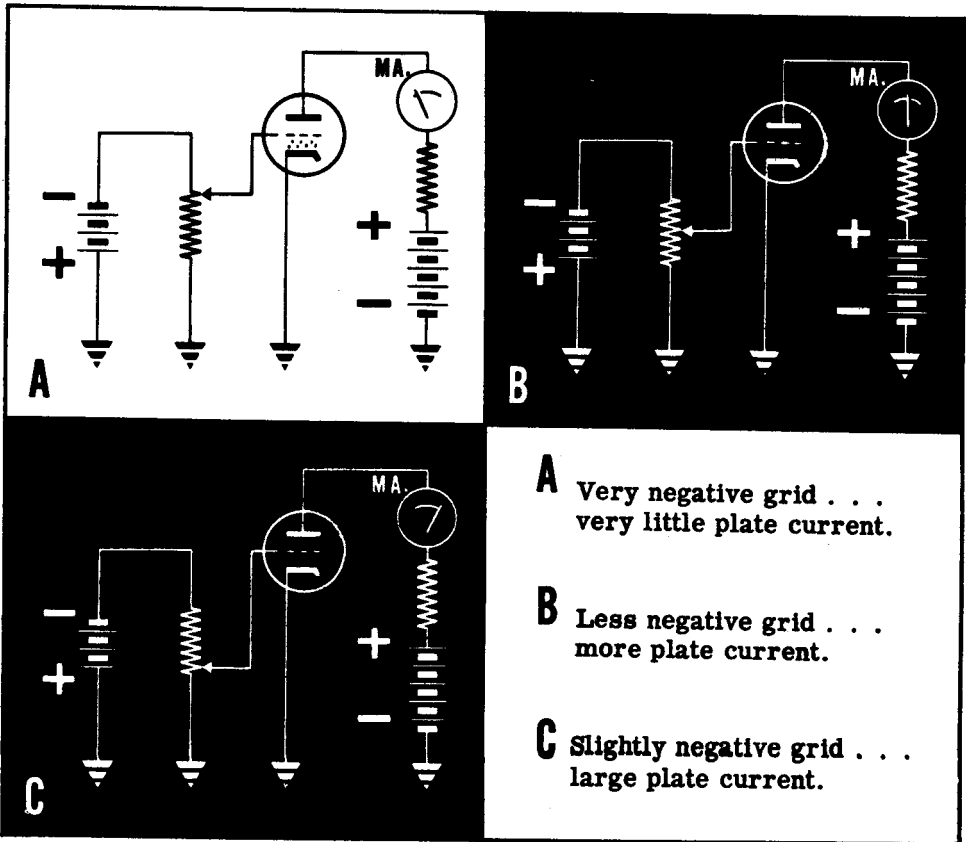

THE TRIODE

How Amplifiers Work (continued)

Now a small flow of electrons from the cathode to the plate means that only a small number of electrons flow from the plate to the B+ lead of the power supply, and a large flow of electrons from cathode to plate means a large current flow from the plate to the B+ lead of the power supply.

A change in current appearing at the plate of a tube is of no direct use, but, if this plate current change can become a plate voltage change, the original voltage change appearing at the grid will have been amplified. The way to accomplish this is to put a resistor between the plate and B+. You know that whenever the electron flow through a resistance changes, a voltage change is produced across that resistance. This voltage change is many times larger than the voltage change on the grid. Since the plate or output voltage changes by the same amount as the voltage across the resistor, the amplified grid voltage change appears at the output.

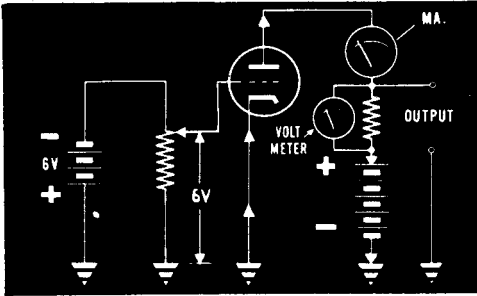

- VERY NEGATIVE GRID
- VERY LITTLE PLATE CURRENT
- VERY LOW VOLTAGE DROP ACROSS PLATE LOAD RESISTOR

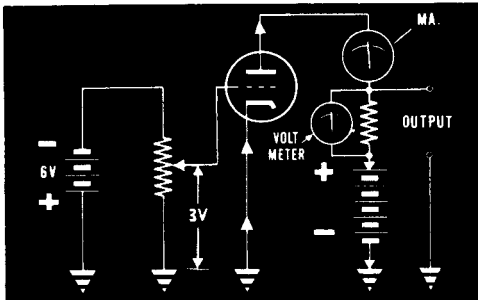

- LESS NEGATIVE GRID
- MORE PLATE CURRENT
- LARGER VOLTAGE DROP ACROSS PLATE LOAD RESISTOR

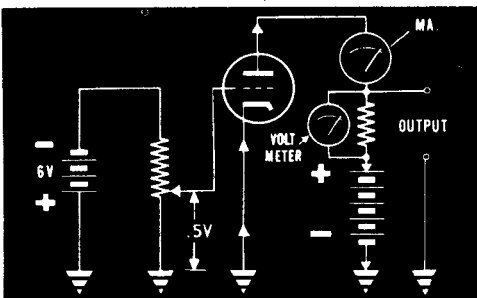

- SLIGHTLY NEGATIVE GRID
- LARGE PLATE CURRENT
- VERY LARGE VOLTAGE DROP ACROSS PLATE LOAD RESISTOR

Using this circuit with certain types of vacuum tubes, the change in plate voltage can be made more than 200 times the change in grid voltage—a voltage gain or amplification of over 200.

THE TRIODE

How Amplifiers Work (continued)

Let's take a look at a triode circuit and see how amplification is accomplished. The cathode-to-plate current flows through the load resistor which is in series with the plate and causes a voltage drop across the plate. Therefore, as long as current is flowing, the voltage on the plate is less than B+ by an amount equal to the drop across the load.

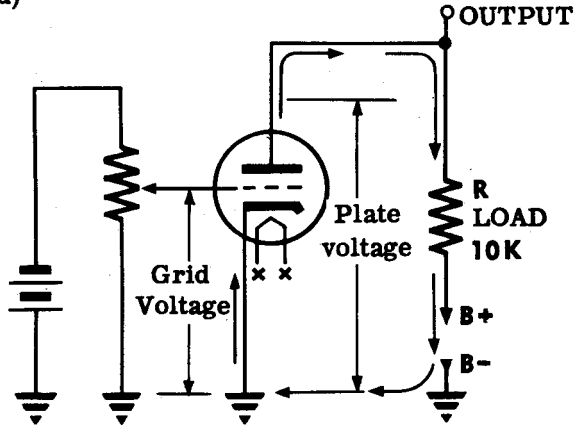

Now a slight change in grid voltage causes a large change in plate current and this causes a corresponding change in the voltage drop across the load resistor. If the voltage drop across the load resistor increases, the plate voltage will decrease by the same amount. This change in plate voltage is called the "output voltage." Because a change in grid voltage produces a much larger change in plate voltage, the triode amplifies.

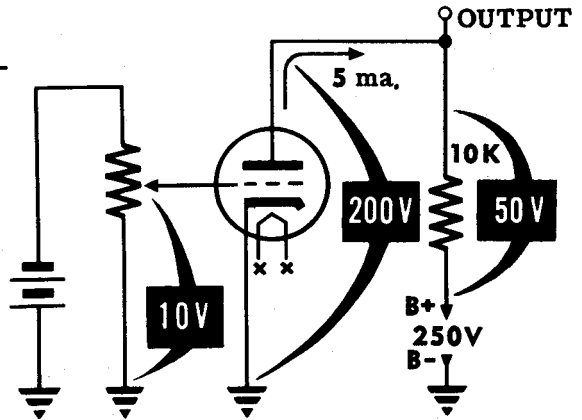

Here is an example of what happens in an actual tube: With the grid voltage = -10 volts, load resistor = 10K ohms, B+ = 250V, the plate current that flows is 5 ma. This current causes a voltage drop across the load of $E = IR = .005 \times 10,000 = 50$ volts. Therefore, the plate voltage is 200 volts (250 - 50).

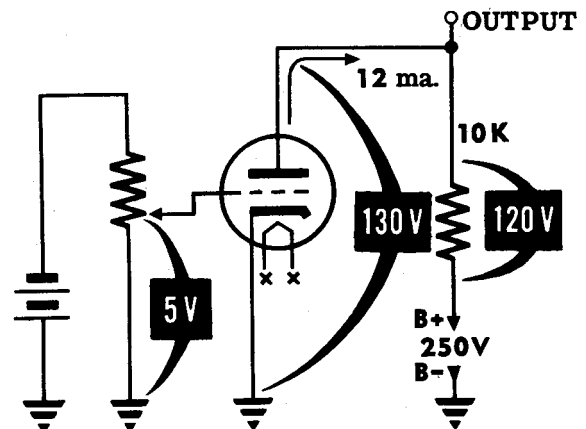

Now let's change the grid voltage from -10 volts to -5 volts (less negative). The current increases to about 12 ma., the drop across the load is 120 volts—an increase of 70V, and the voltage on the plate is now only 130 volts—a decrease of 70V. Note that the sum of these two voltages still adds up to the B+ voltage of 250V. Thus, a change of only 5 volts on the grid has changed the plate voltage 70 volts—an amplification of 14 times.

THE TRIODE

Tube Characteristics—Amplification Factor

Since the grid voltage and plate voltage can be used to control the flow of current to the plate, it is important to see which does the better job. If you look at the results of tests, you will see that a small change in grid voltage can produce a large change in plate current while a much larger change in plate voltage is necessary to produce the same plate current change.

The ratio of the effectiveness of the grid and plate in controlling plate current is called Mu, and the Greek letter μ is used to represent it.

From these results we can say that the grid of the tube is much more effective than the plate in controlling plate current.

$\mu = \frac{\text{Change in plate voltage}}{\text{Change in grid voltage}}$ to produce the same change in plate current.

Actually the Mu of tube is much more than a ratio. It tells you how much a vacuum tube is able to amplify a signal that is applied to its grid. For example, suppose you find that when the grid voltage is changed from -2 to -4 (a change of 2V) the plate current changed the same amount as it did when the plate voltage was changed from 140V to 100V (a change of 40V). The ratio of these two voltage changes is 20 to 1, which means that if one volt of AC is applied to the grid of the tube, 20 volts of AC will appear in the plate circuit. The tube, therefore, has amplified an AC signal 20 times. For this reason the Mu of a tube is also known as the amplification factor.

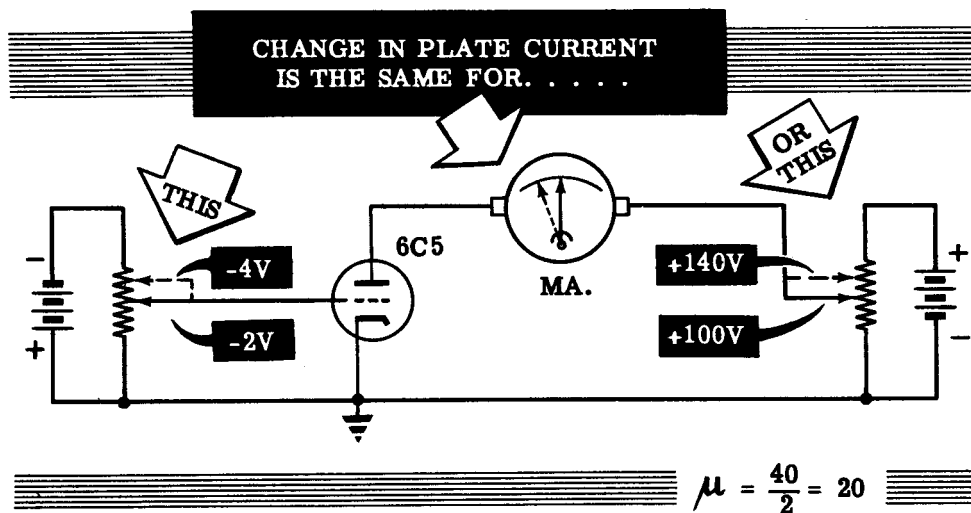

THE TRIODE

Tube Characteristics—Plate Resistance

The plate resistance of a tube is the internal opposition offered, between the cathode and plate, to the flow of the alternating component of plate current. When the tube is operating with an AC voltage on the grid, the number of electrons flowing to the plate changes, and this affects the internal or plate resistance of the tube.

This plate resistance is the ratio of a change in plate voltage to a change in plate current with the grid voltage constant. For example, the 6C5's plate resistance can be determined from the results of a test where the plate voltage will be varied and plate current values recorded for a constant grid voltage. Suppose the test curve indicates that a change in plate voltage from 100V to 150V produced a change in plate current of 5 ma. Since the plate resistance is —

$$r_p = \frac{\text{Change in plate voltage}}{\text{Change in plate current}} \text{ —for a constant grid voltage}$$

then

$$r_p = \frac{50}{.005} = 10,000 \text{ ohms.}$$

The plate resistance is not the same for all vacuum tubes. For triodes it will range from 2,000 to 100,000 ohms and for pentodes it may be as high as 1 megohm.

DETERMINING THE *Plate Resistance* OF A TRIODE

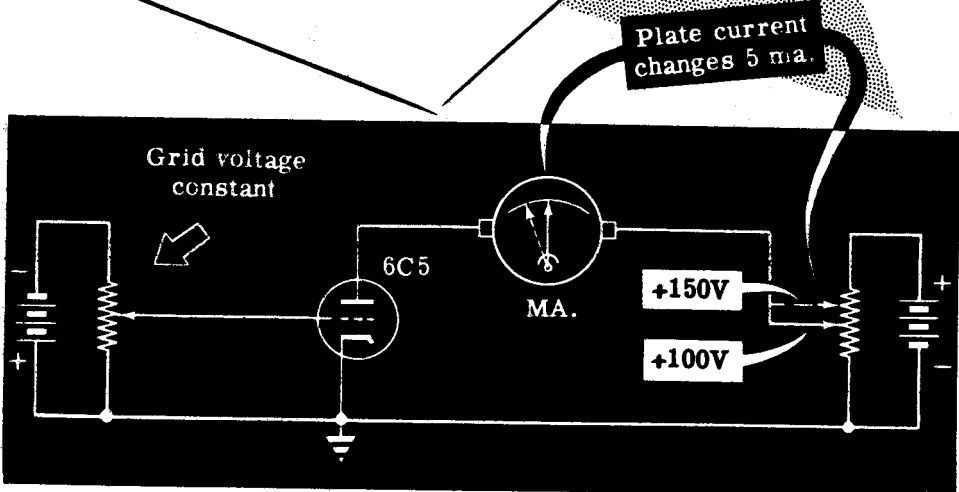

THE TRIODE

Tube Characteristics—Transconductance

So far you have learned about two characteristics of vacuum tubes—the μ or amplification factor and the internal plate resistance— r_p . Another characteristic—transconductance—is obtained from the relationship of μ and r_p . Transconductance is a measure of how effective the grid is in controlling plate current and it is expressed as the ratio of μ to r_p .

$$\text{Transconductance } (g_m) = \frac{\mu}{r_p} \text{ in mhos}$$

In simplified form, g_m represents the effect of a changing grid voltage on plate current with the plate voltage held constant.

The g_m of a tube is expressed in micromhos which is one millionth of a mho, pronounced "mo"—ohm spelled backwards. It is used as the unit of transconductance since conductance is the opposite of resistance.

Using the μ and r_p from the previous sheets, the g_m of the 6C5 can be determined.

$$g_m = \frac{\mu}{r_p} = \frac{20}{10,000} = .002 \text{ mhos}$$

$$g_m = 2000 \text{ micromhos}$$

For most vacuum tubes, the transconductance is usually several thousand micromhos. Tubes with a high μ and low r_p will have a high g_m .

DETERMINING THE *Transconductance* OF A TRIODE

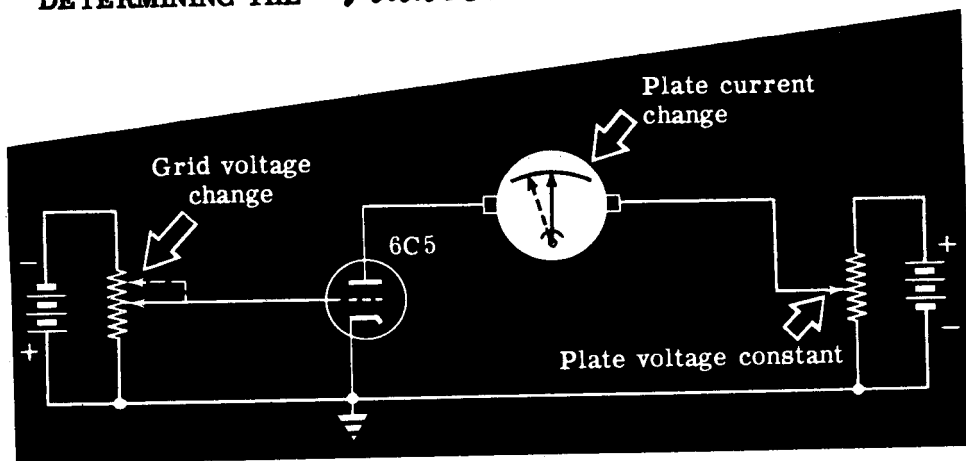

THE TRIODE

Review of Triode Characteristics

Curve 1: You can see that cut-off for this particular tube is about -14 volts with 200 volts on the plate. As the grid voltage is made less negative, the current increases along the E_g-I_p curve. A portion of the curve is straight or linear. On this linear portion the plate current variations are uniformly proportional to the grid voltage variations. In this linear region a change of 2 volts on the grid produces a change of about 4 ma. in the plate current. The graph shown here is called the E_g-I_p curve. E_g = grid voltage and I_p = plate current.

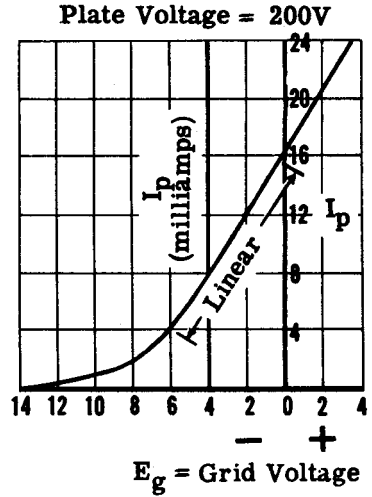

Curve 2: With the grid voltage set at -8 volts, it is seen that changes of plate voltage affect the plate current. But a 10-volt change on the plate causes only a very small change in the plate current. By comparing the results in curve 1 and curve 2, you can see that the grid exerts a greater control on the plate current than does the plate.

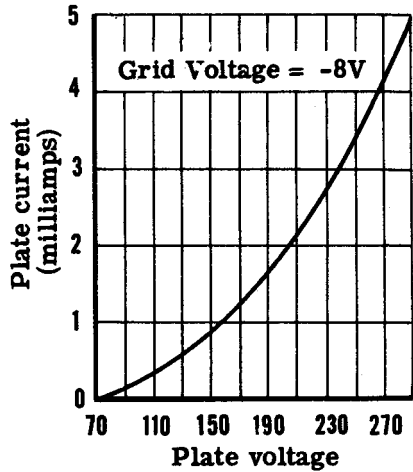

Curve 3: While the tube is cut off (from grid voltages of -14 and beyond) no current flows and there is no voltage drop across the plate load resistor. The plate voltage is equal to $B+$ while the tube is cut-off. When the grid voltage becomes less negative, plate current flows and a voltage drop is developed across the load resistor, causing the plate voltage to drop. Along the linear portion of the curve, a 2-volt change on the grid produces a change of about 30 volts on the plate. This is a gain (amplification) of 15.

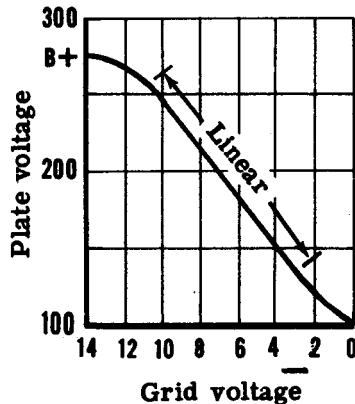

THE TRIODE AMPLIFIER

Grid Bias Voltage

You should know how the plate current of a triode behaves under different operating conditions. If you look at curve 1 on the previous page, you will see that when the grid is made positive with respect to the cathode, the plate current rises to high values. When the grid is made sufficiently negative with respect to the cathode, plate current drops to zero. These are the extreme conditions in the operation of a triode.

We are concerned with triodes used as amplifiers, and for this purpose they are normally operated with the grid negative to prevent distortion of the signal. This confines the operation to the left portion of the E_g - I_p curve (curve 1). The voltage which keeps the grid negative is called the "grid bias voltage." Grid biasing is simply the process of making the grid negative with respect to the cathode.

When a tube is used as an amplifier, two voltages in series are applied between grid and cathode:

1. The negative DC grid bias voltage which fixes the point of operation on the E_g - I_p curve. This bias voltage may be obtained from a battery or any other source of DC voltage. Various types of bias supplies will be discussed later.
2. The AC signal voltage, which for the present will be in the audio frequency range.

In the sheets which follow, you will see how the AC signal adds to and subtracts from the bias voltage to produce corresponding changes in plate current.

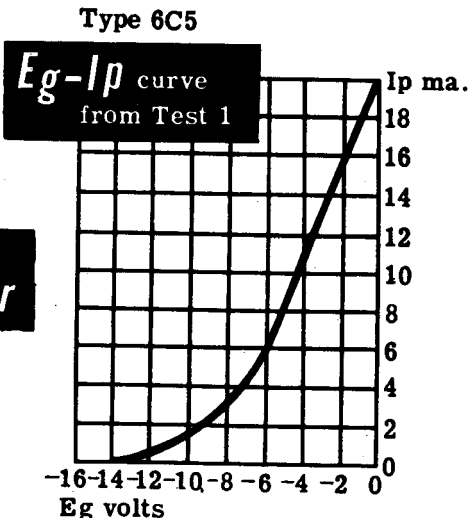
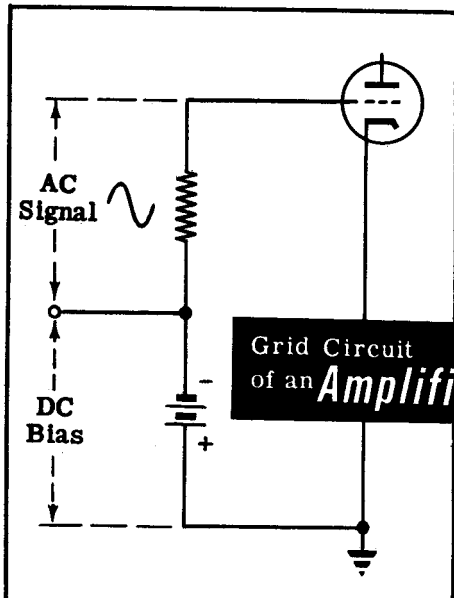

THE TRIODE AMPLIFIER

Grid Bias Voltage (continued)

If an AC signal is applied to the grid, the current flowing in the plate circuit will vary in the same manner as the signal voltage. The positive half cycle of the applied signal voltage is in series opposing with the bias voltage and therefore subtracts from it. The negative half cycle of the signal voltage is in series aiding with the bias voltage so that addition of the two voltages takes place. As a result, the AC signal voltage causes the grid to cathode voltage to be alternately less negative and more negative. This varying negative voltage between grid and cathode allows more and less current to flow so that the plate current variations will be a duplicate of the applied signal voltage.

THIS

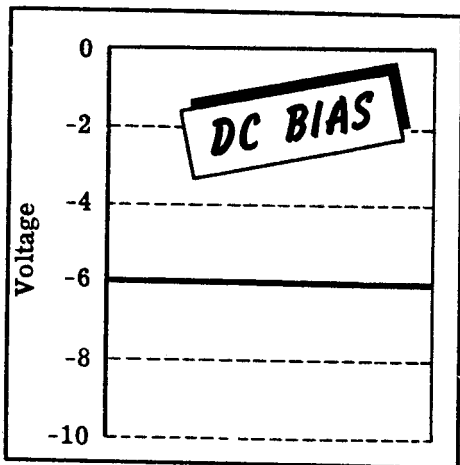

+ THIS

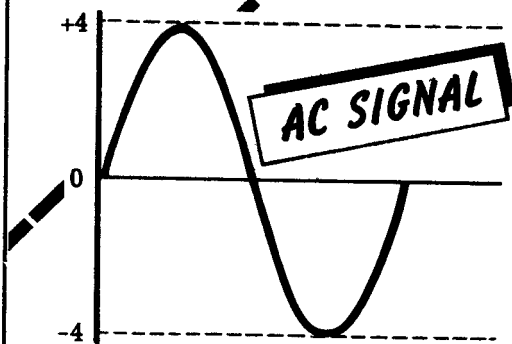

-6
+4
-2

= THIS

COMBINATION OF DC BIAS
AND AC Signal Voltage

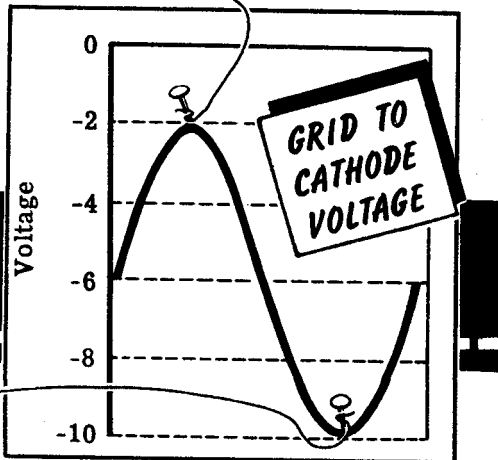

-6
-4
-10

THE TRIODE AMPLIFIER

Grid Bias Voltage (continued)

Let us consider the following example which will illustrate the points just made. Suppose a 6C5 triode is connected in a circuit with $-4V$ bias voltage applied to the grid and $+200V$ applied to the plate. With no signal applied, the plate current will be a steady 11 ma . This can be seen by referring to the E_g - I_p curve.

When an AC signal of $2V$ is applied to the grid, the positive half cycle will subtract $2V$ from the bias causing the grid to cathode voltage to change from $-4V$ to $-2V$. The negative half cycle will add to the bias and cause the grid to cathode voltage to change from $-4V$ to $-6V$. You can see that the grid to cathode voltage is varying from $-2V$ to $-6V$ around the $-4V$ bias.

The plate current depends on the amount of negative voltage between grid and cathode. This negative voltage is now varying in the same manner as the applied signal. Therefore, the plate current will vary in accordance with the applied signal.

When the grid voltage varies so that the plate current varies in accordance with the applied AC signal, the amplifier is called "Class A," and is operating on the linear portion of the E_g - I_p curve. You will learn more about the classes of operation a little later.

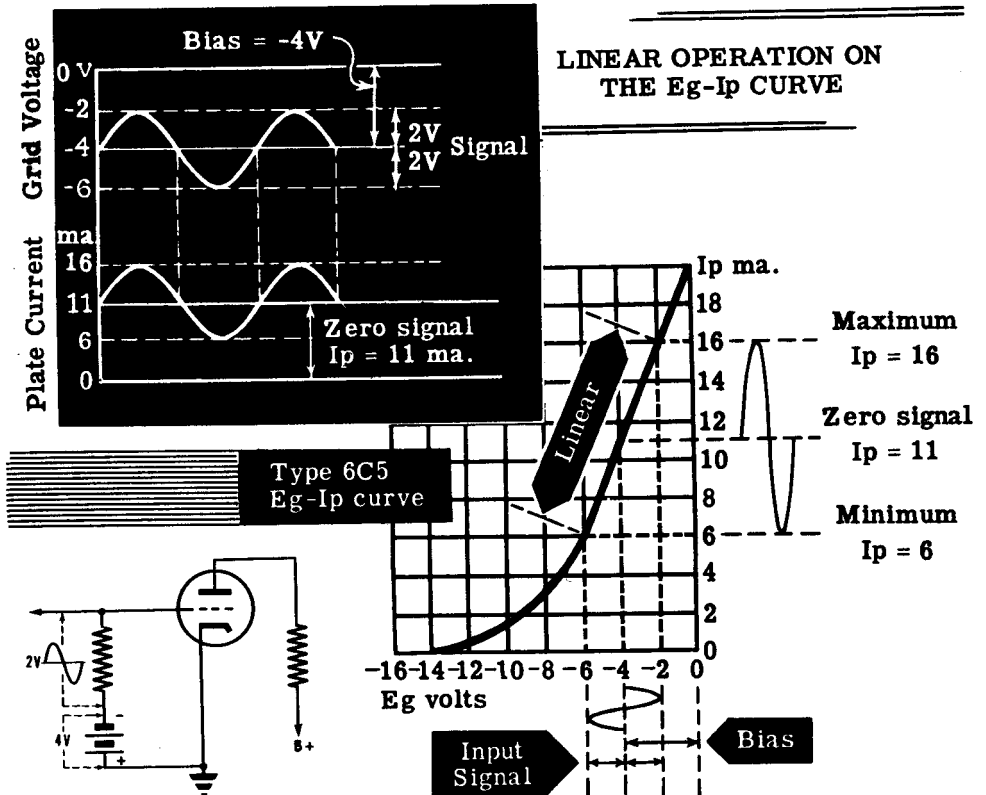

THE TRIODE AMPLIFIER

Why Proper Bias Is Necessary

To obtain an amplified output voltage at the plate we must use the plate current variation. In the example on the previous sheet, a 5 ma. AC component was produced in the plate circuit by applying a 2V AC signal to the grid.

Suppose we look at the plate circuit of the triode. If an 8,000 ohm plate load resistor (R_L) is used, the steady or zero-signal plate current of 11 ma. will produce a DC voltage drop across the load of $E = I \times R = .011 \times 8000 = 88V$. The DC plate voltage is 200V and the total DC voltage ($B+$) is the sum of the load voltage and plate voltage or 288V.

DC Voltage Distribution ... IN A TRIODE AMPLIFIER

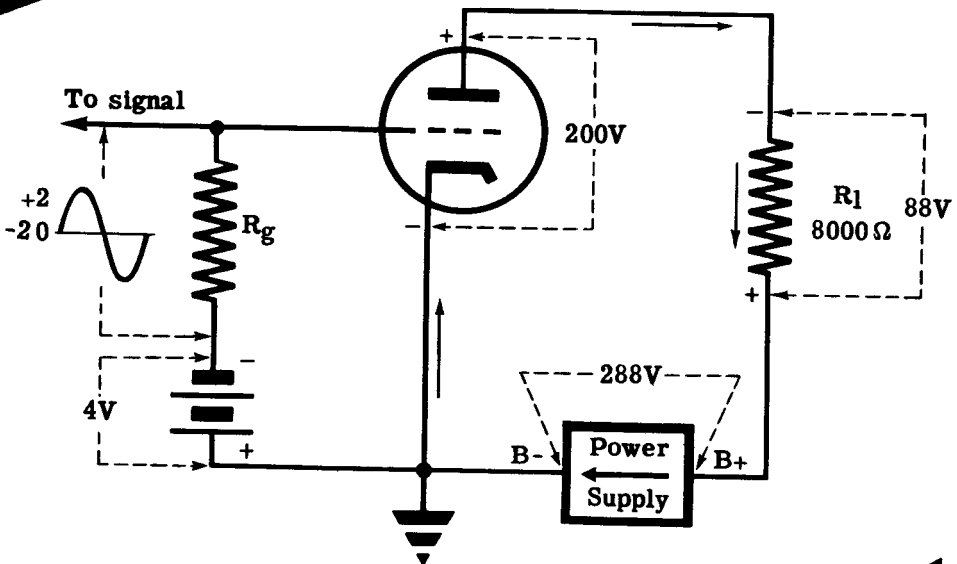

On the next sheet you will see how the load voltage and the plate voltage change when the signal is applied to the grid.

THE TRIODE AMPLIFIER

Why Proper Bias Is Necessary (continued)

When the signal is applied to the grid, the plate current increases to 16 ma. (5 ma. increase) and decreases to 6 ma. (5 ma. decrease). When 16 ma. flows through the load, the voltage drop across the load will be $E = I \times R = .016 \times 8000 = 128V$, an increase of 40V ($128 - 88 = 40V$). This will make the plate voltage decrease 40V since the total voltage must always add up to the B+ voltage of 288V. Therefore, the plate voltage will decrease from 200V to 160V. (Note: $160V + 128V = 288V$)

When the plate current decreases to 6 ma. the voltage drop across the load will be $E = I \times R = .006 \times 8000 = 48V$, a 40V decrease from its steady value of 88V. Since the total voltage must still be up to 288V, the plate voltage will increase from its steady 200V to 240V. (Note: $240V + 48V = 288V$).

You can see from the illustration below that the 5 ma. AC component of plate current produces a 40 volt variation across the plate load resistor and an equal and opposite variation in plate voltage. Since a 2V AC signal on the grid initially produced the plate current variation, the 40V signal at the plate is an amplified version of the grid signal.

A 2V signal on the grid has produced a 40V signal at the plate which means that we have amplified the signal 20 times. Note that this amplified signal at the plate is 180 degrees out of phase with the signal on the grid.

You will see on the next sheet that the correct bias is necessary if the plate current variation and likewise the plate voltage variation is to be an exact duplicate of the grid signal.

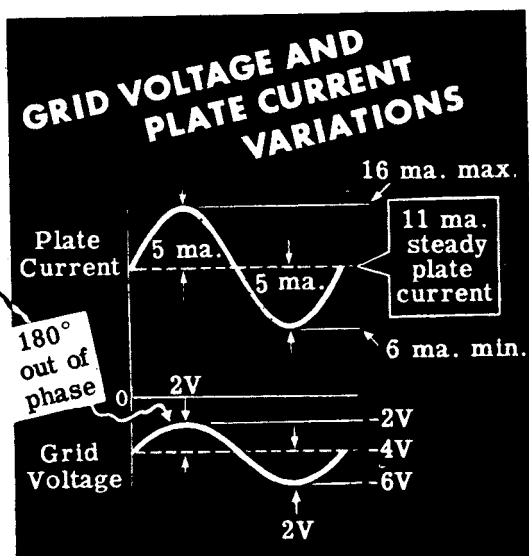
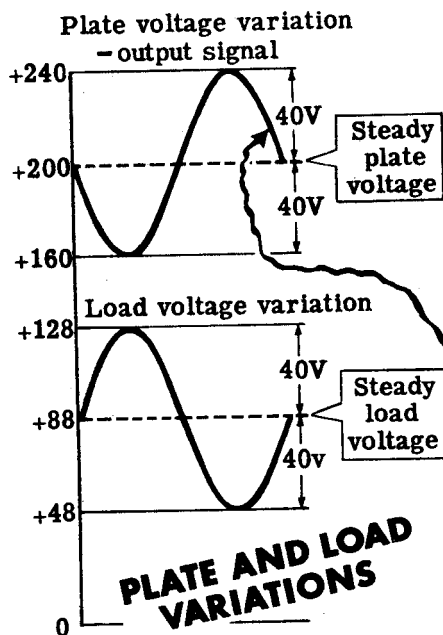

THE TRIODE AMPLIFIER

Why Proper Bias Is Necessary (continued)

Notice that although the signal itself was positive during one half cycle, the grid to cathode voltage was never positive—it just became more negative or less negative. The bias point for this amplifier was selected so that it fell in the center of the straight-line or linear portion of the Eg- I_p curve. Operation on the linear portion is essential if the output wave form is to have the same shape as the input wave form. Operating at incorrect bias voltages will produce distortion of one form or another. If too much bias is used, (making the grid voltage more negative) the signal will drive the tube into cut-off during the negative half cycle and produce a distorted plate current variation. If too little bias is used, the signal will drive the grid positive during the positive half cycle. This will cause the grid to take some electrons from the cathode that would normally have gone to the plate. Again the result is a distorted plate current variation. These conditions are illustrated below.

Distortion will result with the correct bias voltage if the input signal is too large. The large signal will drive the grid into both the positive and the cut-off regions—producing distortion.

You can now see that proper bias is necessary if the plate current variation is to look exactly like the grid signal variation. If the amplifier tube is biased in the center of the linear portion of the Eg- I_p curve and the tube is not overdriven (excessive signal), very little distortion will result. Incorrect bias will result in a distorted output signal.

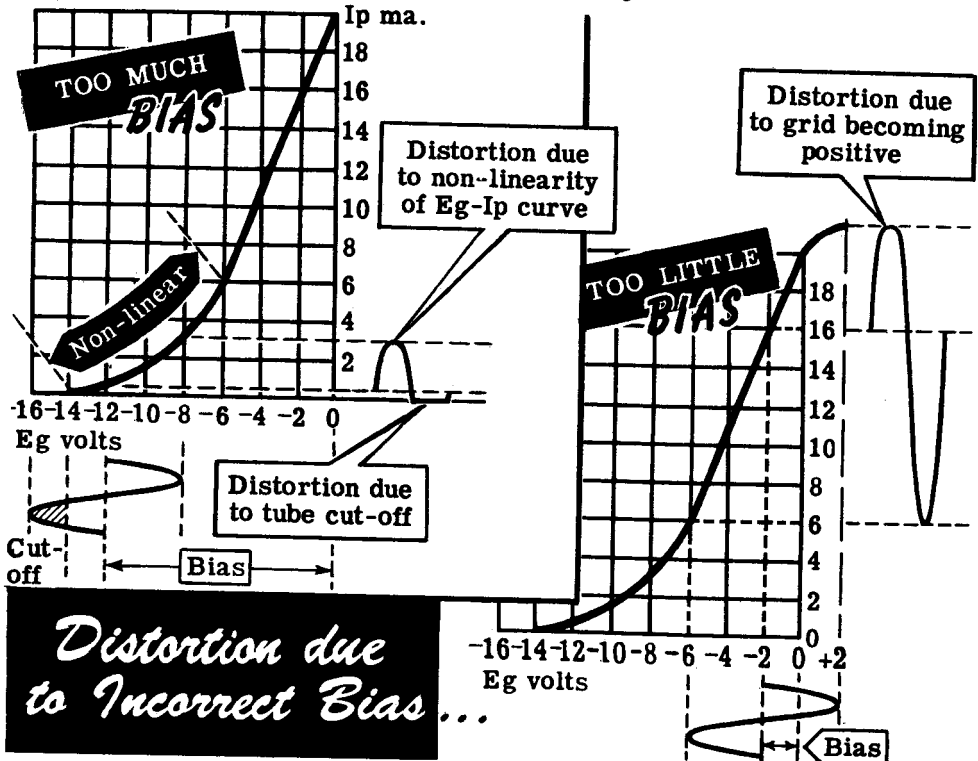

THE TRIODE AMPLIFIER

Classes of Amplifiers

The class of an amplifier is determined by its point of operation on the Eg- I_p curve. There are three major classes of amplifiers—Class A, B and C. Class A amplifiers are biased to operate in the center of the linear portion of the Eg- I_p curve. The amplifier described in the previous sheets is a Class A amplifier. Class B amplifiers are biased to operate near cut-off and Class C amplifiers operate at a point where the bias voltage is equal to twice the cut-off voltage of the tube.

The figure below shows the bias voltages for the three different classes of amplifiers. For this particular tube, the bias would be $-2V$ for Class A operation. Since Class B operates at cut-off, its bias voltage must be $-4V$. For Class C operation, the bias must be $-8V$ because a Class C amplifier operates at a bias equal to twice the cut-off value.

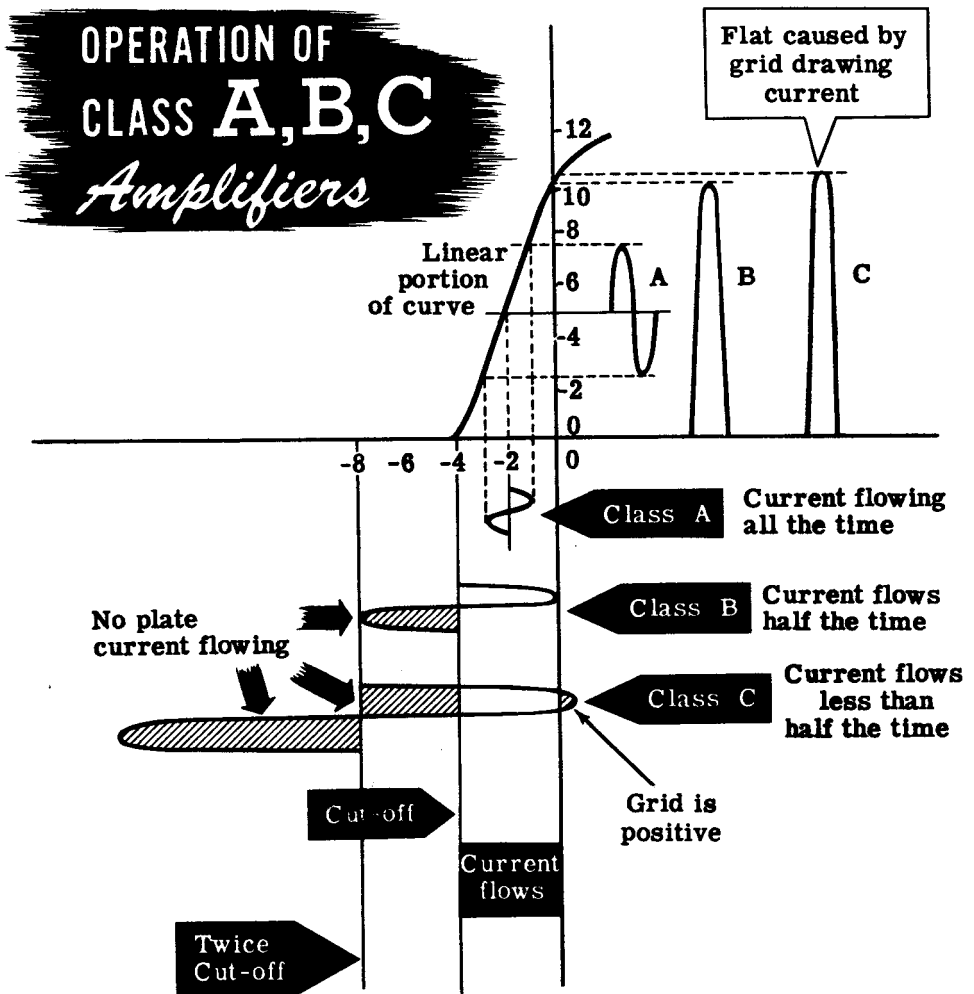

THE TRIODE AMPLIFIER

Classes of Amplifiers (continued)

The figure shown on the previous sheet is a comparison of the operating characteristics of Class A, B, and C amplifiers. This is what you should see from the illustration—

Class A

The signal is small. It is never large enough to drive the grid either positive or beyond cut-off. Plate current flows during the complete cycle of signal input. The plate current variation is an exact duplicate of the grid signal.

Class B

The signal is larger than for Class A. The grid may be driven positive. The signal drives the grid beyond cut-off for approximately half the input cycle. Only the positive half cycle of input appears in the plate circuit. The total plate current change is much greater than the change produced by Class A operation. Plate current flows for approximately half the complete cycle. Plate current is zero when no signal is put into the grid.

Class C

The applied signal is the largest of the three classes. The grid is driven beyond cut-off and into the positive grid region. The plate current variation is the largest of the three classes. The peak of the current wave has a dip because the control grid is drawing current, thereby reducing the amount of current available to the plate. Plate current flows for less than half a cycle of input voltage. Without a signal on the grid, no plate current flows. A large signal voltage is necessary to drive the grid positive during each cycle. This class is used only in RF (radio frequency) power amplifiers.

The Class A amplifier is used primarily as a voltage amplifier. Class B and Class C amplifiers are used as power amplifiers and are designed to deliver high currents.

There are combinations of Class A and Class B amplifiers and these are called Class AB₁ and AB₂. Class AB₁ amplifiers are biased to a point slightly more negative than Class A amplifiers. Class AB₂ amplifiers are biased to a point slightly less negative than that of Class B. These classes of operation are actually compromises between Class A and Class B.

THE TRIODE AMPLIFIER

Battery Bias

Battery bias was chosen for the first illustration of bias because it is the easiest to understand. In actual practice, you will find it used only in the laboratory or for experimental work. The battery type is reliable and efficient, but the size and weight of batteries make it difficult to use in most equipment.

Whenever batteries are used as a source of bias voltage, it is desirable to use a combination of cells in series that add up to the required voltage. With this arrangement, it is not necessary to use regulating devices, such as potentiometers, which draw current from the battery and gradually consume its power. Most bias or "C" batteries are made in multiples of 4-1/2 volts—4-1/2, 9, 18 volts and higher. These batteries are tapped for intermediate voltages. The negative terminal of the battery is connected to the grid through the resistor R_g , the positive terminal is connected to the cathode. This makes the grid negative with respect to the cathode.

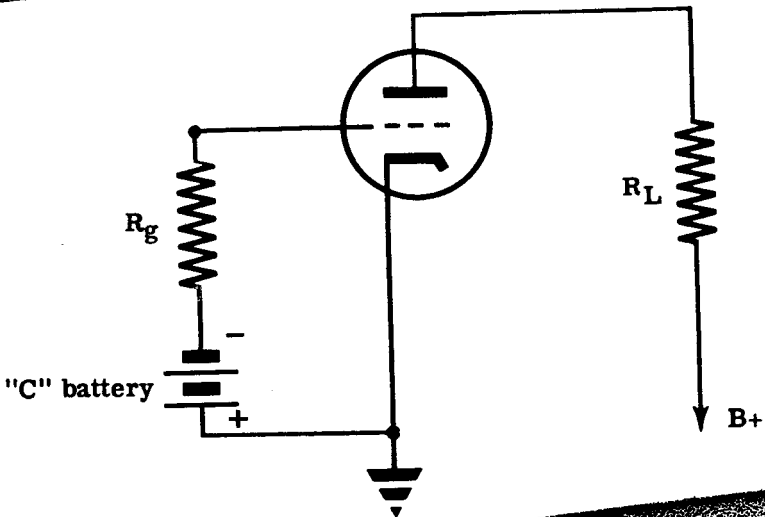

Battery **BIAS**

THE TRIODE AMPLIFIER

Power Supply Bias

Rectifier power supplies replace "B" batteries in the plate circuit and also are used to replace the "C" batteries. In large equipment, such as some transmitters, a separate bias power supply is used. It may be a generator, a half-wave rectifier or a full-wave rectifier. The positive side of the power supply is connected to the cathode and the negative side is connected to the grid, just as is done with a "C" battery. In the illustration below, the positive terminal of the bleeder resistor is connected to ground and the negative terminal is connected to the grid through R_g . Since the cathode is grounded, the grid is negative with respect to the cathode.

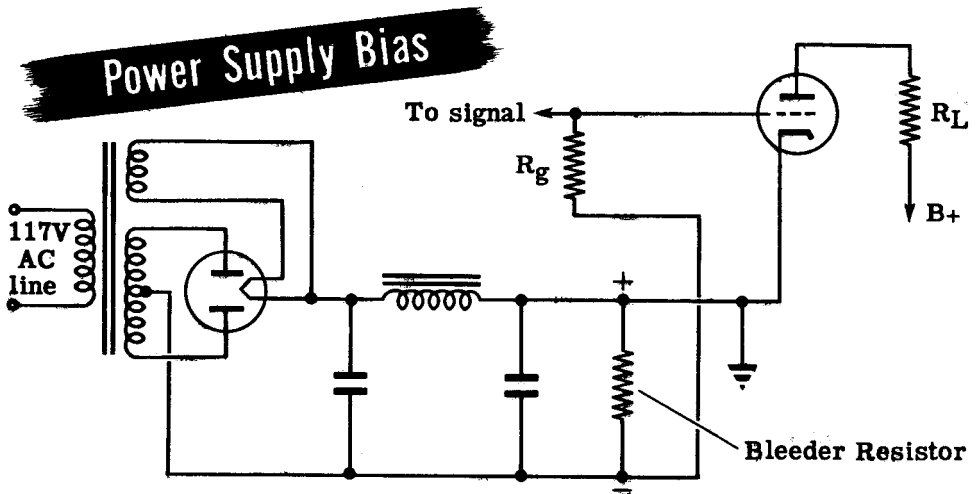

Power Supply Bias-Generator Type

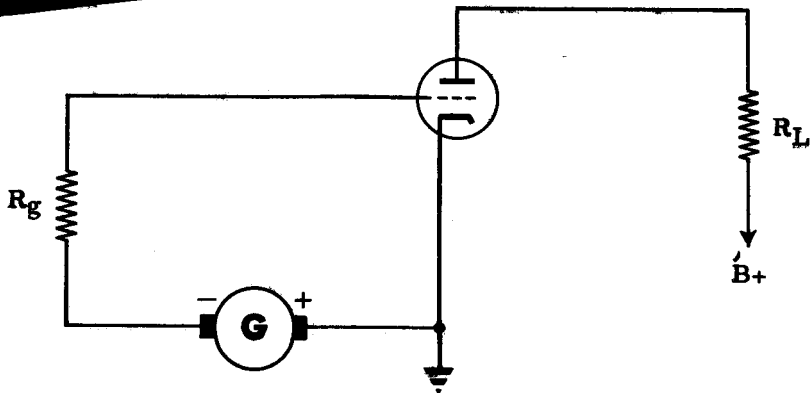

THE TRIODE AMPLIFIER

B+ Power Supply Bias

A negative and a positive voltage with respect to ground can be obtained from the same power supply. This is done by connecting two resistors in series across the power supply and grounding the junction of these resistors. A single tapped bleeder resistor can be used in place of the two resistors in series. The resistance to ground from the negative terminal is much smaller than the resistance from the positive terminal to ground. Therefore, the voltage across the positive portion of the bleeder will be greater than that across the negative portion. In other words, this circuit provides a large positive voltage with respect to ground which is used as the B+ plate supply voltage, and a small negative voltage with respect to ground which is used as grid bias voltage. The cathode is connected to ground, the plate is connected to the positive terminal of the bleeder through R_L , and the grid is connected to the negative terminal of the bleeder through R_g . Therefore, the grid is made negative and the plate is made positive, with respect to the cathode.

Negative Bias AND Positive Plate Voltage

FROM THE SAME POWER SUPPLY

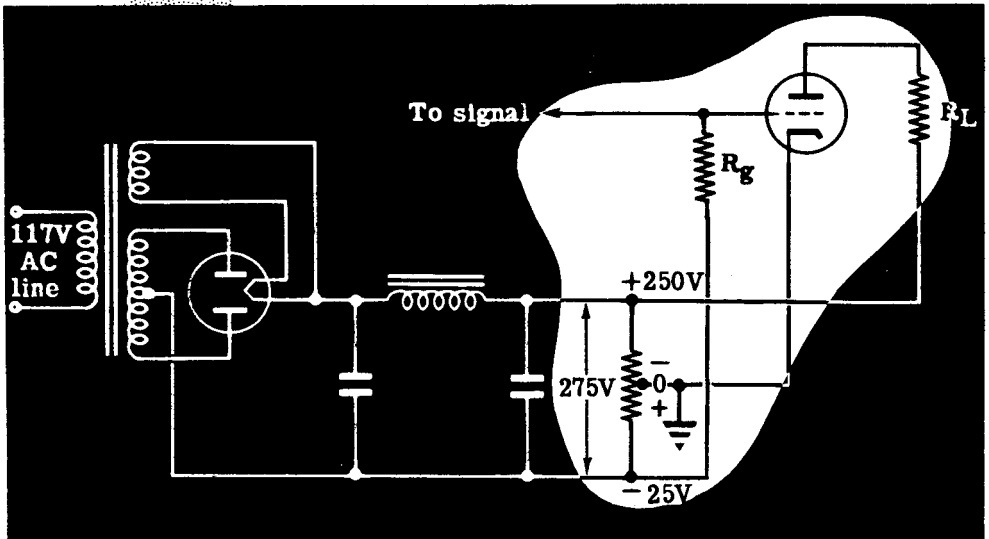

THE TRIODE AMPLIFIER

Cathode Bias

Of all bias systems, cathode bias is the most widely used. Cathode bias is obtained by connecting a resistor in series with the tube from B- or ground to the cathode.

In order to understand how this system works, it will be necessary for you to recall three points

1. If current flows through a resistor an IR drop will be produced.
2. The end of the resistor toward which the current is flowing is the most positive (+).
3. The purpose of bias is to keep the grid negative with respect to the cathode.

Look at the illustration below. Notice that a resistor (R_k) has been placed in the cathode circuit of the vacuum tube, between cathode and ground. All the current that flows through the tube must flow up from B- through the cathode resistor. This produces an IR drop across the cathode resistor, making the cathode positive with respect to ground. Since the grid is connected to ground through R_g and ground is negative with respect to the cathode, the grid is also negative with respect to the cathode.

CATHODE BIAS

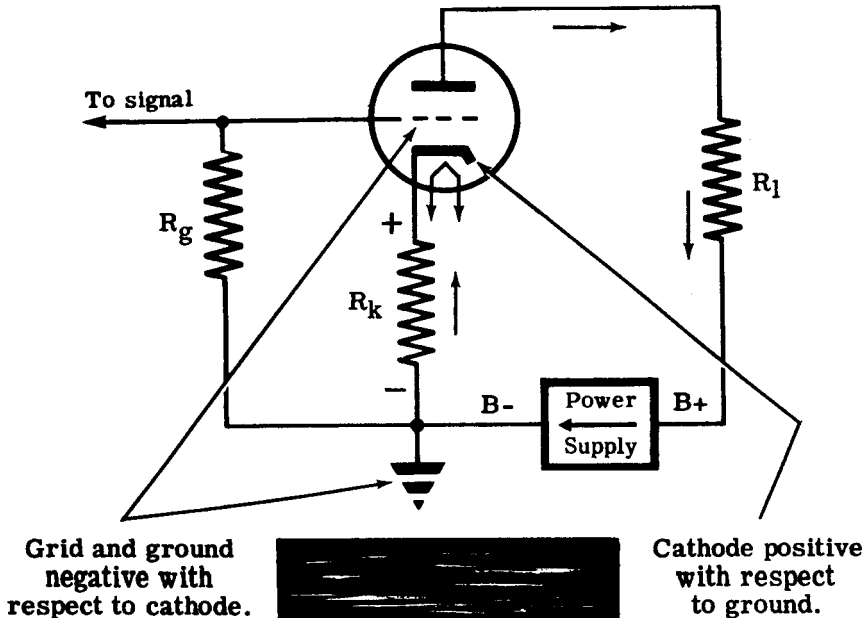

THE TRIODE AMPLIFIER

Cathode Resistor

Determining the size of the cathode resistor (R_k) is merely an arithmetic problem. Suppose that a tube requires a bias of -6 volts for proper operation and a plate current of 4 ma. flows with this bias. The 6-volt bias is produced by 4 ma. flowing through the cathode resistor. Using Ohm's law—

$$R_k = \frac{E}{I} = \frac{6}{.004} = 1500 \text{ ohms}$$

To determine the size of the cathode resistor for a triode, divide the required bias voltage by the plate current.

DETERMINING THE SIZE OF
THE CATHODE RESISTOR
FOR A TRIODE

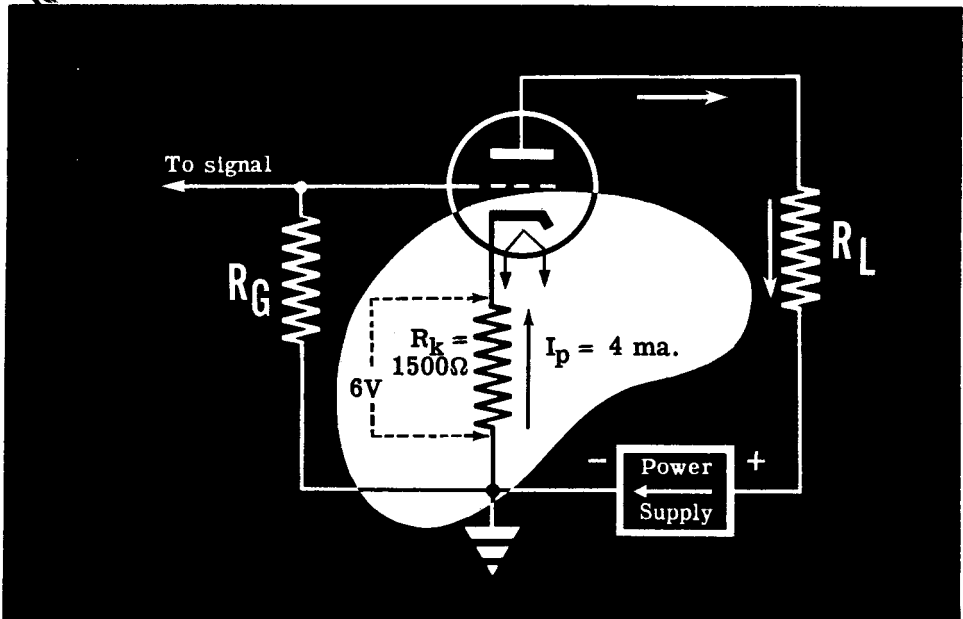
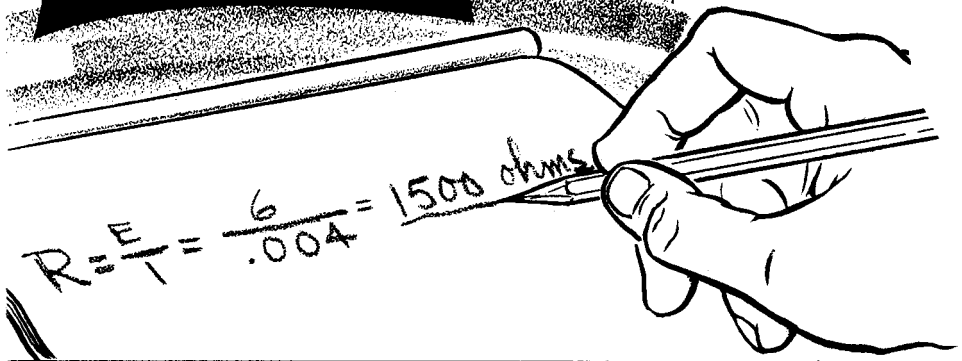

THE TRIODE AMPLIFIER

Cathode Resistor (continued)

In a triode, the only current that flows from the cathode of the tube is the plate current. This is not the case in the tetrode or pentode. Tetrodes and pentodes have a screen grid which has a positive voltage applied to it and attracts electrons from the cathode. Since all the current that flows through the tetrode and pentode must come from the cathode, the total cathode current is:

$$\text{PLATE CURRENT} + \text{SCREEN CURRENT} = \text{CATHODE CURRENT}$$

If a pentode, for example, has a plate current (I_p) of 6 ma. and a screen current (I_{sg}) of 2 ma., the cathode current would be 8 ma. If the required bias is 4 volts, using Ohm's law the value of R_k can be calculated—

$$R_k = \frac{E}{I} = \frac{4}{.008} = 500 \text{ ohms}$$

You will learn more about the construction, use and operation of tetrodes and pentodes in a later topic.

DETERMINING THE SIZE OF THE CATHODE RESISTOR FOR A PENTODE OR TETRODE

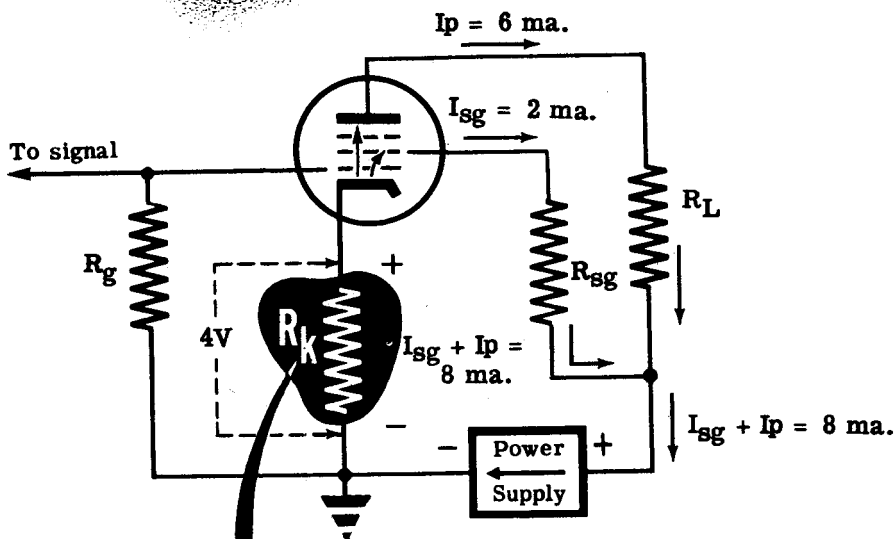

$$R_k = \frac{E}{I} = \frac{4}{.008} = 500 \text{ ohms}$$

$$R_k = 500 \text{ ohms}$$

THE TRIODE AMPLIFIER

Cathode Bypass Capacitor

A cathode bias resistor usually has a capacitor connected in parallel with it. This capacitor is called a bypass capacitor and its purpose is to keep the voltage across the cathode resistor at a constant value.

Suppose we look at the operation of a triode using cathode bias with no bypass capacitor. If a signal is applied to grid, the plate current will vary in accordance with the signal. Since it is the plate current flow through the cathode resistor that produces the bias, and this current flow varies, the bias will also vary.

This varying bias reduces the signal voltage between grid and cathode. On the next sheet you will see how this signal reduction occurs.

TRIODE AMPLIFIER WITH A CATHODE BYPASS CAPACITOR

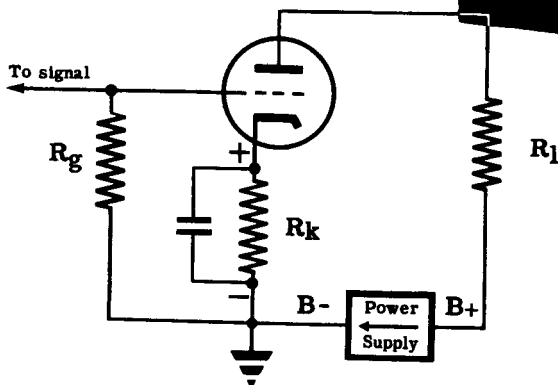

TRIODE AMPLIFIER WITHOUT A CATHODE BYPASS CAPACITOR

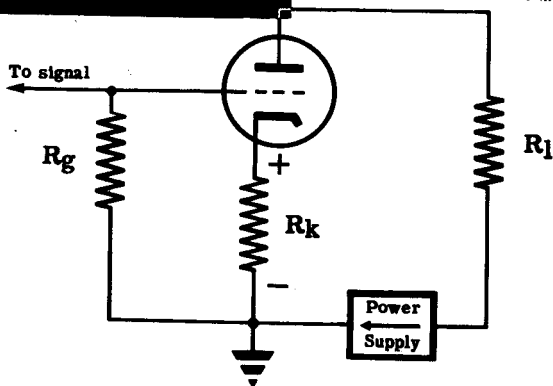

THE TRIODE AMPLIFIER

Cathode Bypass Capacitor (continued)

In the illustration below, an AC signal with a peak amplitude of 6V is applied to the grid of the triode. The triode has a cathode bias voltage of -8V with no signal applied. If the bias voltage remained constant, the signal would add to the bias during its negative half cycle, $(8 + 6) = 14\text{V}$ negative, and it would subtract from the bias during the positive half cycle $(8 - 6) = 2\text{V}$ negative.

With the grid to cathode voltage varying between -14V and -2V, the plate current will be minimum at -14V and maximum at -2V. In this case, assume that the plate current variation produces a voltage variation of 2 volts across the cathode resistor. Observe that the cathode voltage increases (becomes more negative) when the plate current increases and therefore the cathode bias voltage increases when the signal is reducing it (making it less negative). The voltage variation across the cathode resistor is 180 degrees out of phase with the input signal so that the two voltages (signal and cathode voltage variation) subtract from one another to produce an effective voltage variation of $(6 - 2) = 4\text{V}$ between grid and cathode.

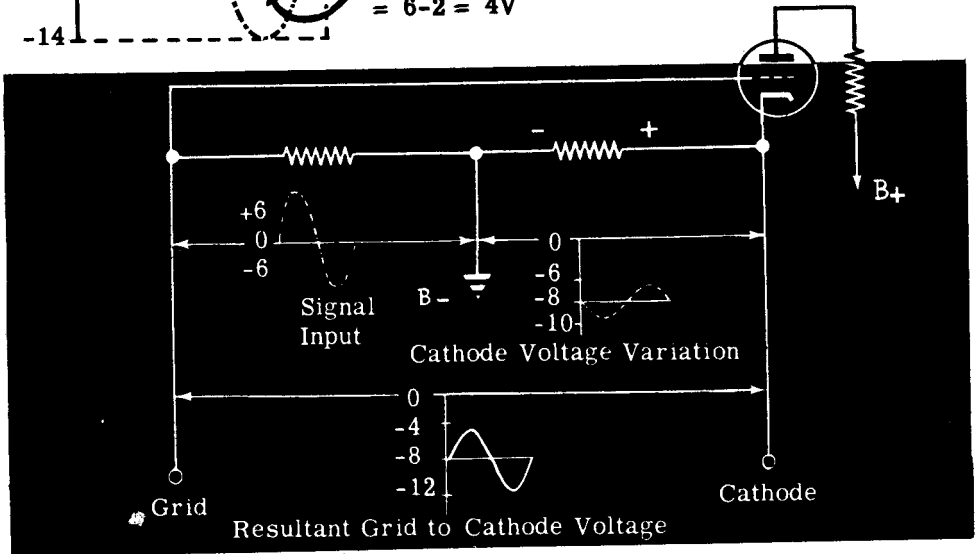
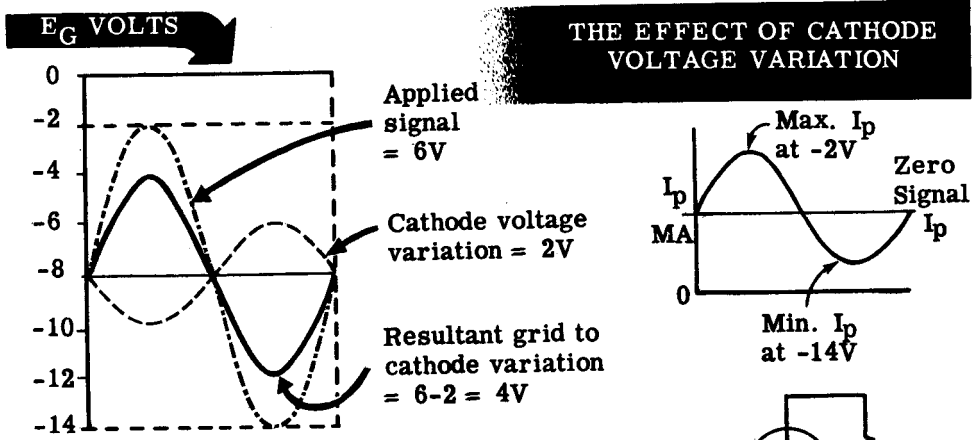

THE TRIODE AMPLIFIER

Cathode Bypass Capacitor (continued)

In other words, the cathode voltage variations cancelled 2 volts of signal. This effect is called degeneration. To eliminate the effect of degeneration, a cathode bypass capacitor is placed in parallel with the cathode resistor. If the proper capacitance is chosen, its capacitive reactance (found by using the formula you learned in Basic Electricity— $X_c = \frac{1}{2\pi fC}$) will be about one tenth the size of the resistor. Since a capacitor will only pass a continuously changing (AC) current, the steady (DC) component of current flows through the resistor and the varying component of current flows through the bypass capacitor. The resistor is virtually shorted out by the low reactance of the capacitor when a current variation occurs. The only current through the resistor is a steady one. Therefore, the voltage across the resistor will remain constant when a signal is applied to the grid and no signal cancellation will take place.

Here is an example of the method used to determine the size of the bypass capacitor. Suppose you had the circuit shown below.

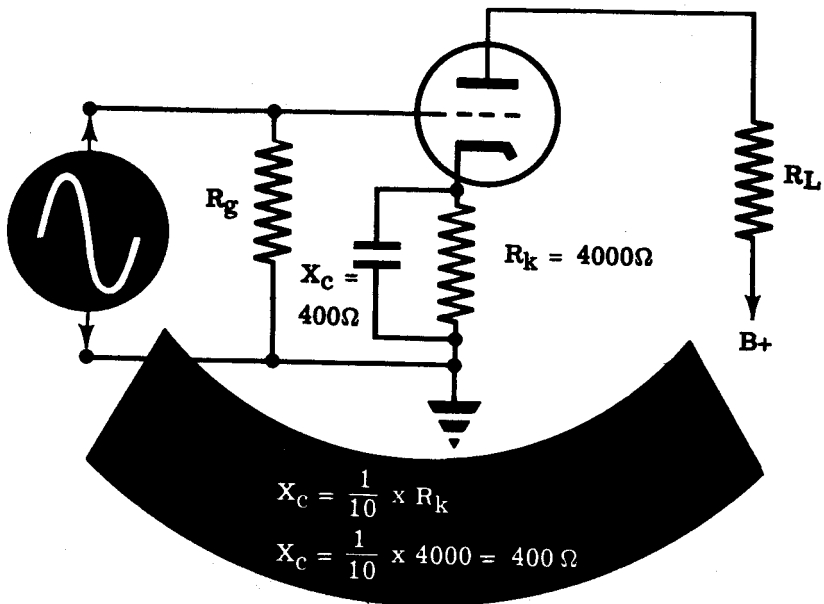

Since $X_c = \frac{1}{2\pi fC}$, the capacity of the bypass condenser can be found by using the formula $C = \frac{1}{2\pi fX_c}$, where f is the lowest frequency signal to be amplified. Suppose f is 60 cps and X_c is 400Ω as shown above, then C will be—

$$\frac{1}{6.28 \times 60 \times 400} \approx 6.6 \text{ mfd.}$$

Since capacitors are not made with a value of 6.6 mfd., a 10 mfd. capacitor would be used.

THE TRIODE AMPLIFIER

Review of Triode Amplifier Operation

GRID BIAS — The amount of grid-bias voltage determines whether an amplifier is operating Class A, Class B or Class C. In Class A the bias is less than cut-off; in Class B bias is at or near cut-off; in Class C bias is much less than cut-off.

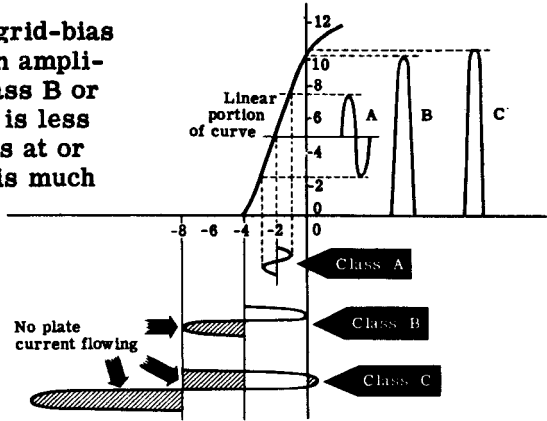

B+ POWER SUPPLY BIAS — A single power supply can be used to supply a positive voltage for B+ and a negative voltage for grid bias.

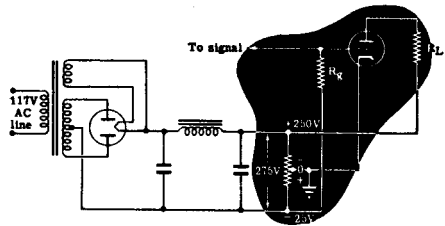

CATHODE BIAS — A cathode bias resistor in parallel with a cathode bypass capacitor in the cathode circuit provide the most widely used system of biasing.

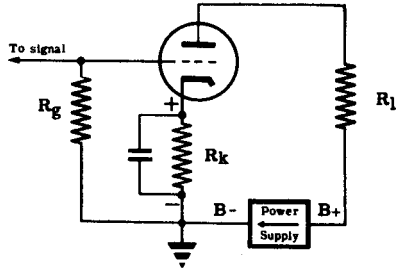

TRIODE AMPLIFIER OPERATION — The variation in voltage output (plate voltage) of a triode, used as an amplifier, may be ten or more times larger than the variation in the grid voltage (AC signal).

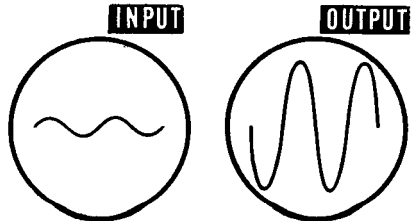

THE TETRODE AND THE PENTODE

Why the Tetrode Was Developed

A capacitor, as you know, is nothing more than two pieces of metal separated by a dielectric (insulator). In a vacuum tube each pair of elements acts as if it were a small capacitor. In a triode there are three such capacitors—one consisting of the grid and plate, one of the grid and cathode and the third of the plate and cathode. These are called the "interelectrode capacitances" and each one has a capacitance of only a few micromicrofarads.

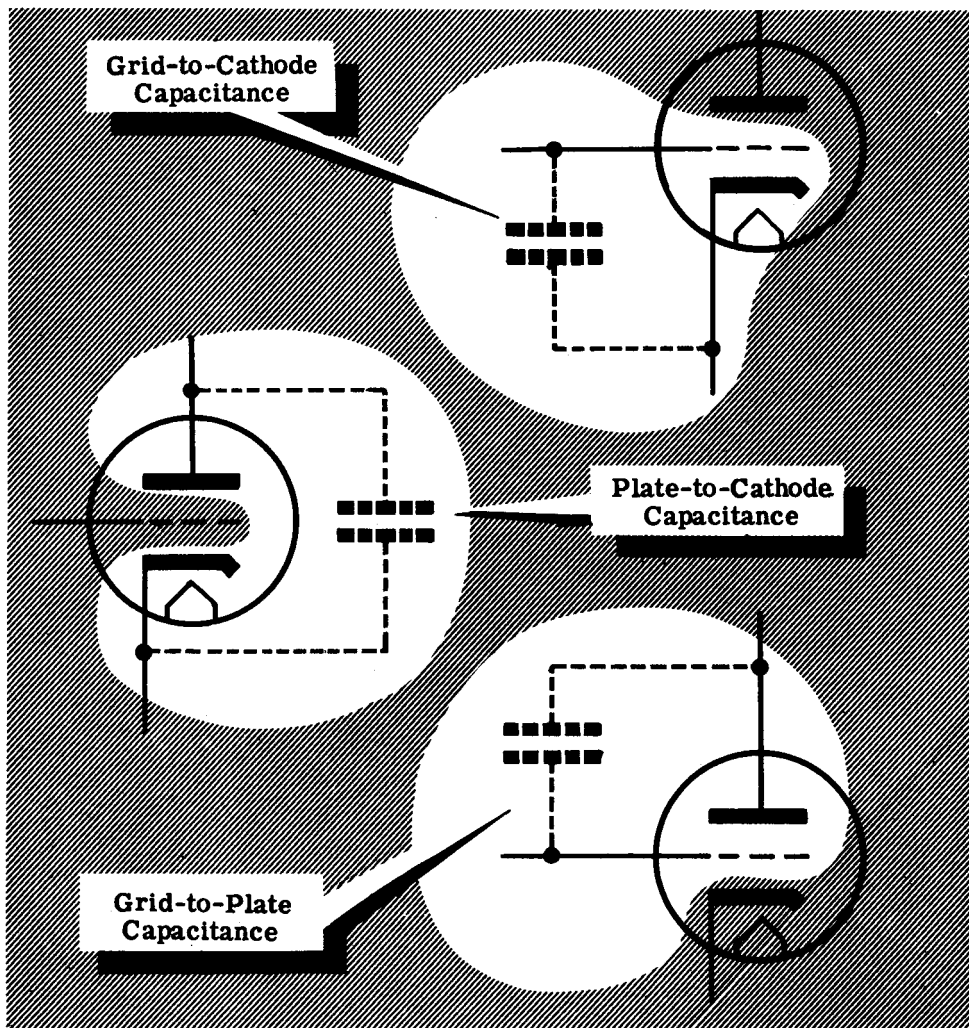

The grid-to-plate capacitance is the one which causes most of the trouble. At high frequencies it produces undesirable effects which may prevent the tube from amplifying properly. This will be explained later.

The tetrode was developed to reduce the interelectrode capacitance between the control grid and the plate.

THE TETRODE AND THE PENTODE

The Screen Grid

In the tetrode a second grid is placed between the control grid and the plate. Now there are two small capacitors in series between the plate and the grid and, of course, the total grid-to-plate capacitance is reduced. This second grid, called the "screen grid," has the effect of shielding the plate from the first grid and allows the tetrode to be used at higher frequencies than the triode could be used.

Normally, the screen grid has a high positive voltage and attracts electrons from the space charge just as the plate did in the triode. However, because the screen grid is a spirally-wound thin wire, most of the electrons pass right through it and end up at the plate. The screen draws only a little current.

TETRODE

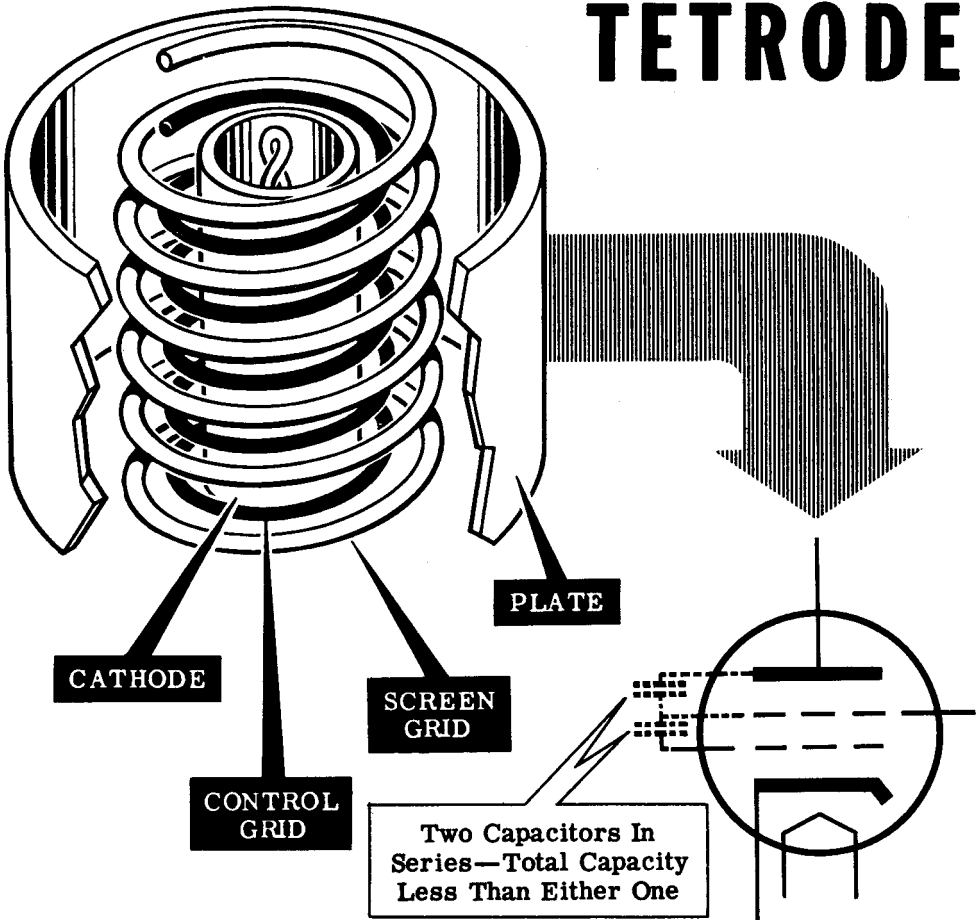

The plate is usually kept at a higher voltage than the screen and the plate circuit does not differ much from that which is used with triodes. In the tetrode, however, the plate voltage has less effect on the tube current than it did in the triode.

THE TETRODE AND THE PENTODE

Secondary Emission in the Tetrode

In any tube—diode, triode or tetrode—when one electron strikes the plate, it knocks several electrons out. Known as "secondary emission," this happens because the electrons are hitting the plate at high speed which becomes ever greater as the plate voltage is raised.

In the triode, secondary emission is not important since the plate is the most positive element in the tube and, therefore, attracts all the electrons that have been knocked out of it. In the tetrode, however, some of these secondary electrons (those which have been freed from the plate as a result of secondary emission) are attracted to the screen. Any flow of secondary electrons from the plate to the screen adds to the screen current and subtracts from the plate current.

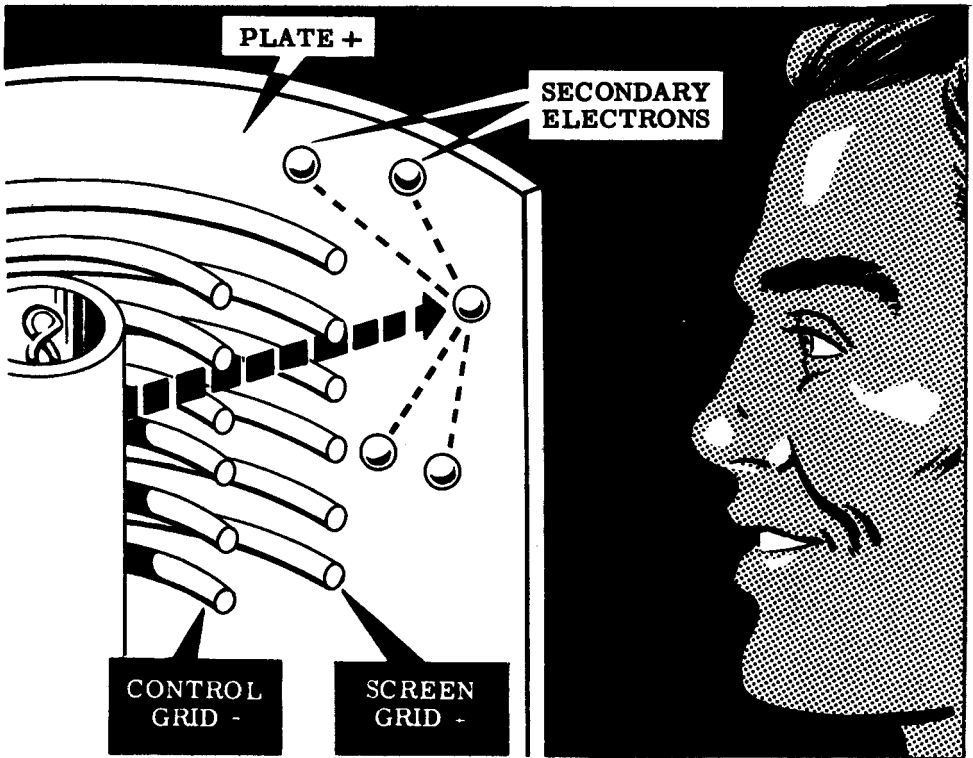

Cutaway Section -- OF A TETRODE

The number of secondary electrons which do not return to the plate depends upon the difference between the plate and the screen voltages. If the plate voltage is much higher than the screen's, all the secondary electrons will return to the plate and there will be no decrease in plate current. If the plate voltage is much lower than the screen's, fewer secondary electrons will be emitted, but all of these will be attracted to the screen.

THE TETRODE AND THE PENTODE

Static Characteristics of the Tetrode

The tetrode is rarely used today, and you are being told about this tube only because it is a "stepping stone" between the triode and the pentode. If static characteristics of a tetrode were taken with varying plate voltage but constant control and screen grid voltages, you would get a curve resembling the one in the diagram.

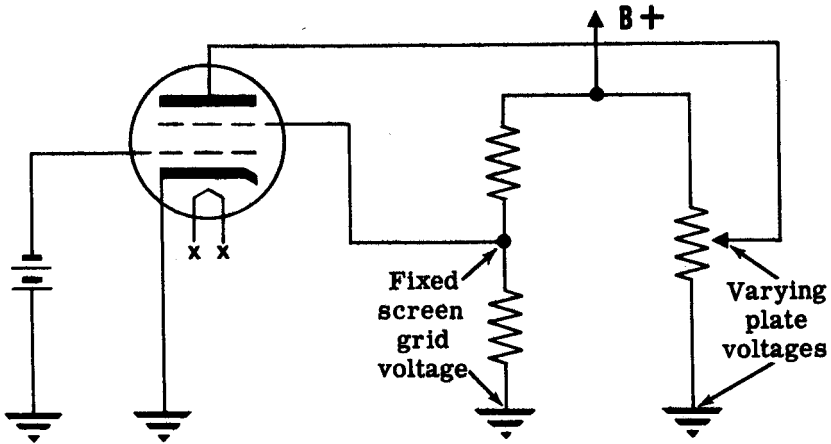

Notice that at high plate voltages above 300V, the plate current does not change when the plate voltage is increased. This is because the screen shields the plate from the space charge at the cathode which causes the screen to exert a greater control over plate current than the plate itself.

At about 100 volts, an increase in plate voltage causes a decrease in plate current because more electrons are knocked out of the plate by secondary emission. As long as the plate voltage is below the screen voltage, almost all the secondary electrons go to the screen.

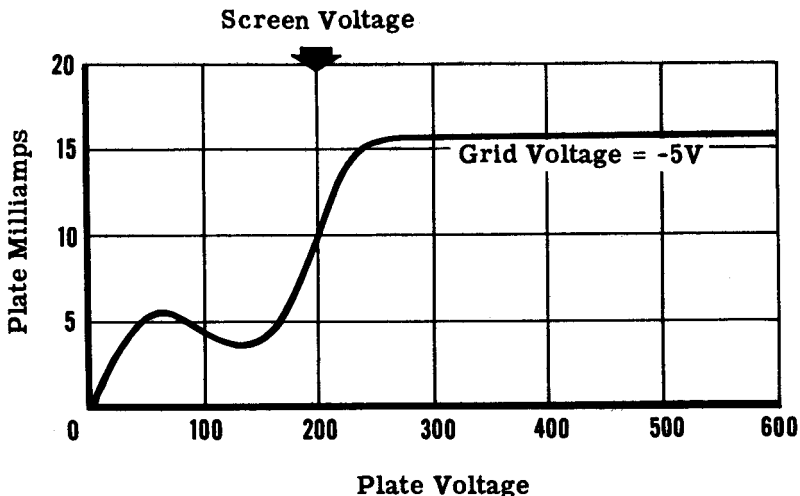

THE TETRODE AND THE PENTODE

Normal Operation of the Tetrode

Cathode bias in the tetrode is obtained in the same way as in the triode, except that in the tetrode the current flowing through the cathode resistor is the sum of the screen and plate currents.

The control grid voltage varies according to the input signal and produces variations in the plate current. Therefore the plate current the screen grid current vary with the control grid voltage. Screen grid voltage variation is prevented by connecting a screen bypass capacitor to ground. This keeps the screen at a fixed DC level and the tube current will be varied only by varying the control grid voltage.

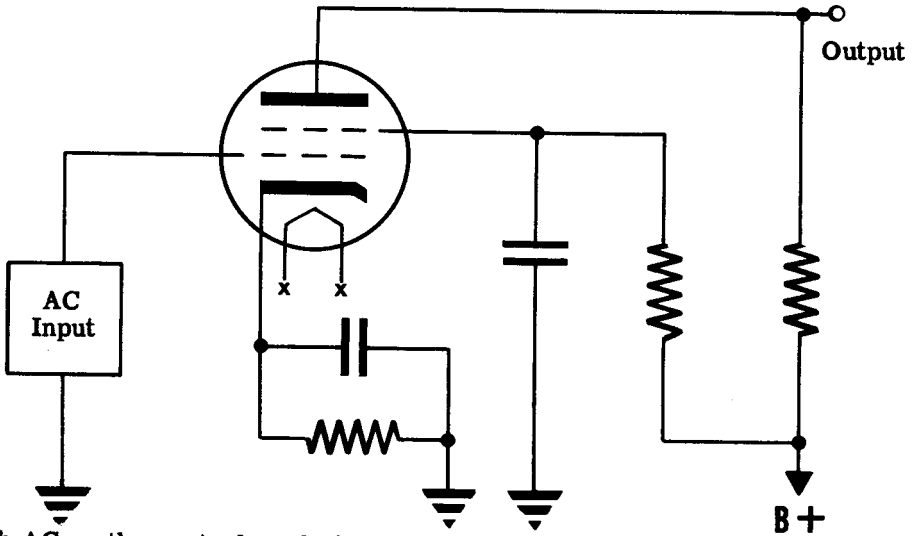

With AC on the control grid of the tube, the plate voltage will vary because of the drop in the load resistor just as in the triode. When the tetrode is used for getting large amplifications, the plate voltage varies over a wide range and, if it drops below the screen grid voltage, secondary emission effects cause distortion in the output.

To prevent this, the plate voltage would have to be very large to keep the plate at a higher potential than the screen regardless of the amount of voltage variation at the plate.

This—the requirement of an abnormally high B+—is the main disadvantage of using a tetrode. You will see how the pentode overcomes this disadvantage.

**DISTORTED OUTPUT OF
TETRODE WITH "LOW"
PLATE VOLTAGE SUPPLY**

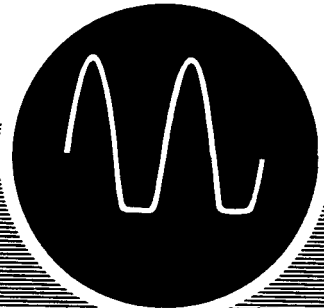

THE TETRODE AND THE PENTODE

Eliminating the Effects of Secondary Emission

You have seen that the main disadvantage of the tetrode is the need for a high plate voltage to prevent distortion in its output due to the effect of secondary emission.

The pentode is designed to overcome this undesirable feature of the tetrode by eliminating the flow of secondary electrons between the plate and the screen grid. This is accomplished by the inclusion of a third grid, the suppressor grid, between the plate and the screen grid.

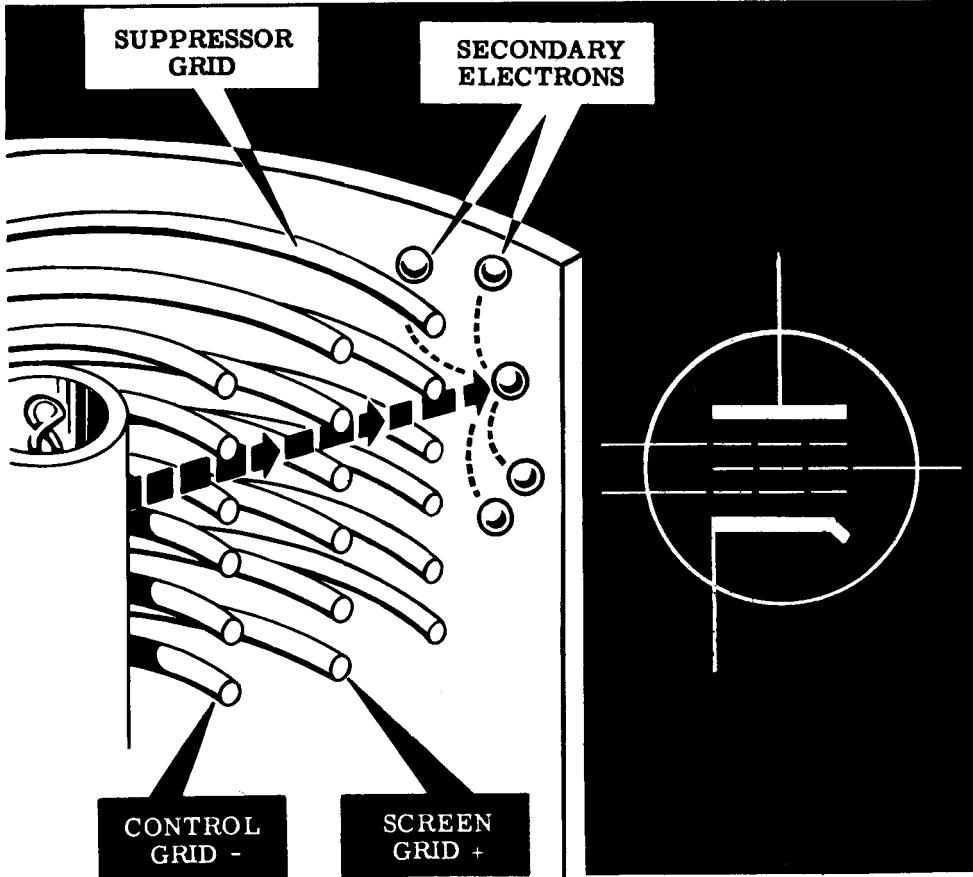

Cutaway Section - - OF A PENTODE

The suppressor grid is usually kept at cathode potential so that it is always very negative with respect to the plate. Therefore, any electron that is in the region between the suppressor and the plate (such as a secondary electron) is attracted back to the plate and prevented from getting through the suppressor to the screen. As a result of this arrangement, secondary emission does not affect the operation of the pentode.

THE TETRODE AND THE PENTODE

How the Pentode Works

You remember that in a triode a decrease of the negative grid voltage produced an increase in the current and a decrease in the plate voltage. The plate voltage change was more than the change in grid voltage. We called the ratio of plate voltage change to grid voltage change "amplification."

You remember too that the plate voltage in a triode also affects the current flow. The decrease in plate voltage has a tendency to decrease the current. The grid is trying to increase the current. It is clear, then, that the decrease in plate voltage is opposing the effect of the grid voltage decrease.

If the grid has 20 times as much control of the current as the plate has, the limit of amplification would be 20. When such an amplification is reached, the plate voltage changes would be 20 times as large as the grid voltage changes and, theoretically, there would be no change in the current. Thus the amplification is limited by the fact that the plate has some effect on the current.

In a pentode, neither the suppressor nor the plate voltage affect the amount of current drawn from the space charge surrounding the cathode since the screen grid shields both of these elements from the cathode. As in the tetrode, the pentode's screen voltage is fixed at some positive value and, therefore, only the variations of control grid voltage cause changes in plate current.

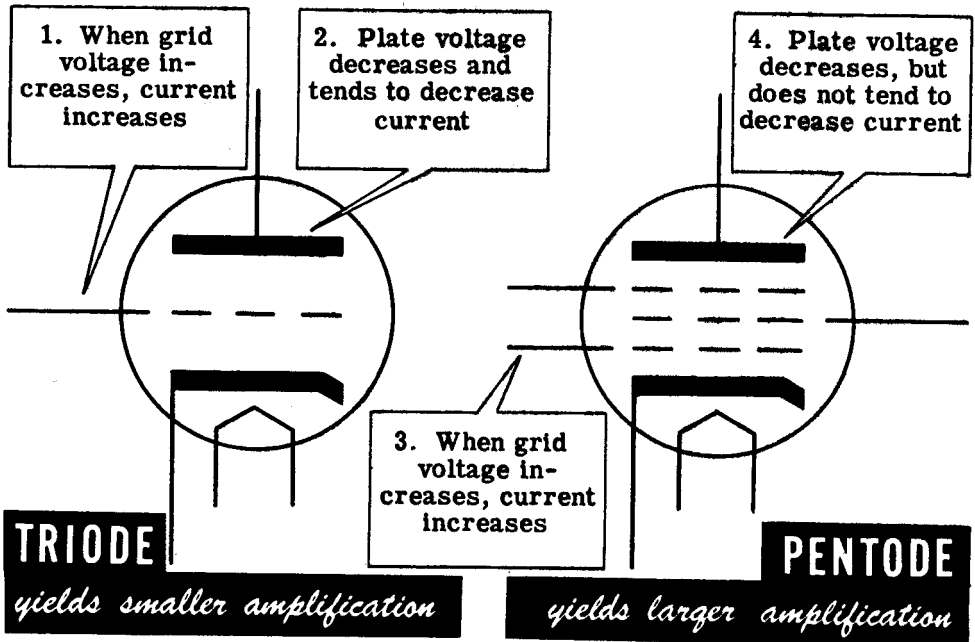

In the pentode the plate voltage can vary considerably with almost no effect on the current and, therefore, with no cancellation of the grid's control of the plate current. As a result, the amplification of a pentode is many times greater than that of a triode.

THE TETRODE AND THE PENTODE

A Typical Pentode Tube

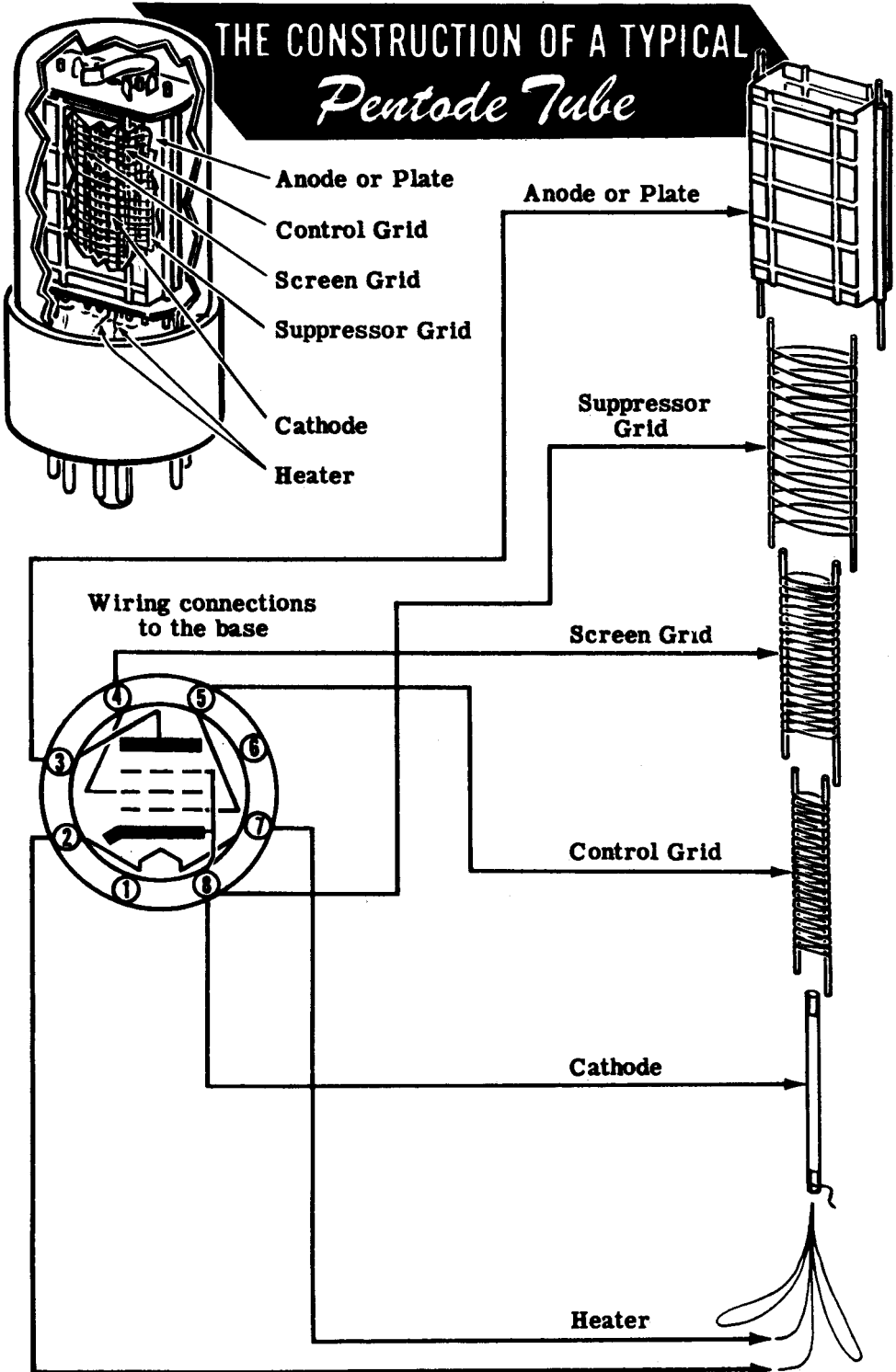

THE TETRODE AND THE PENTODE

The Beam Power Tube

You have learned from your study of the pentode that the suppressor grid reduces the effects of secondary emission. Instead of using the suppressor grid to control secondary emission from the plate, the same effect can be obtained by arranging the tube elements in such a way as to produce a negative charge near the plate. The action of this space charge is to repel any secondary emitted electrons back to the plate just as the suppressor does in the pentode.

The figure below shows the internal structure of a typical beam power tube such as the 6L6, 50L6, 6V6 and others. You see that this tube has a cathode, control grid, screen grid and two new parts—the beam-forming plates which are connected to the cathode. Each beam-forming plate extends about one-fourth the distance around the grids of the tube and prevents any electrons from reaching the plate except through the openings between the beam-forming plates. This tends to concentrate the electron stream into a small area and thereby form an electron beam.

The openings in the grids are arranged in such a way that the electrons pass between the grid wires in layers or sheets. After passing the screen grid, these electrons combine to form a concentration of electrons, or space charge, near the plate. It is this space charge that does the same job as the suppressor in the pentode.

The beam power tube has an advantage over the pentode in that a greater power output can be obtained for a given amount of cathode emission.

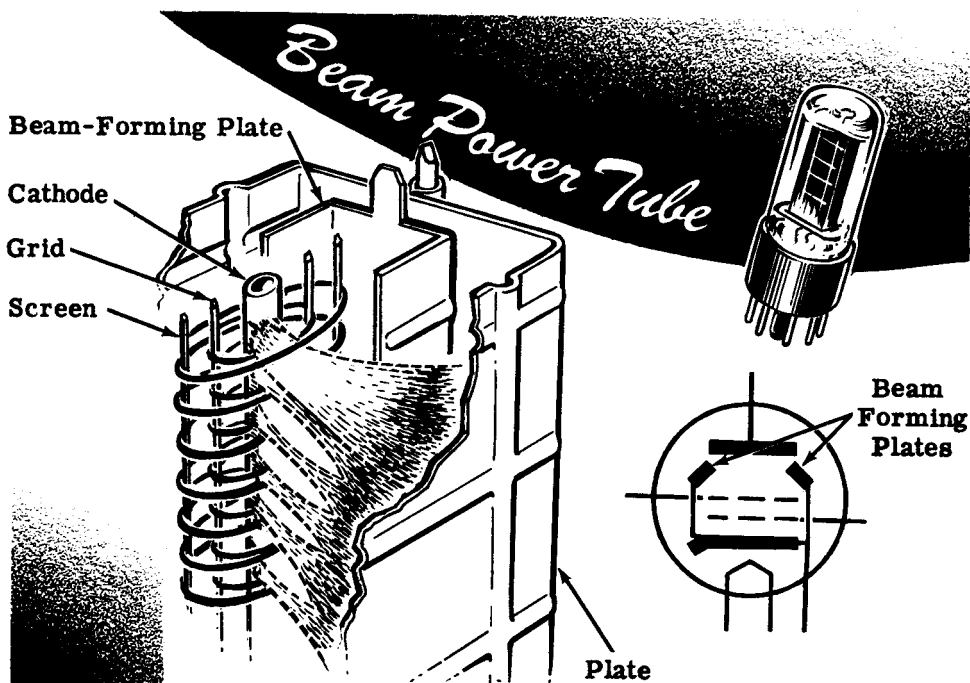

THE TETRODE AND THE PENTODE

The Beam Power Tube (continued)

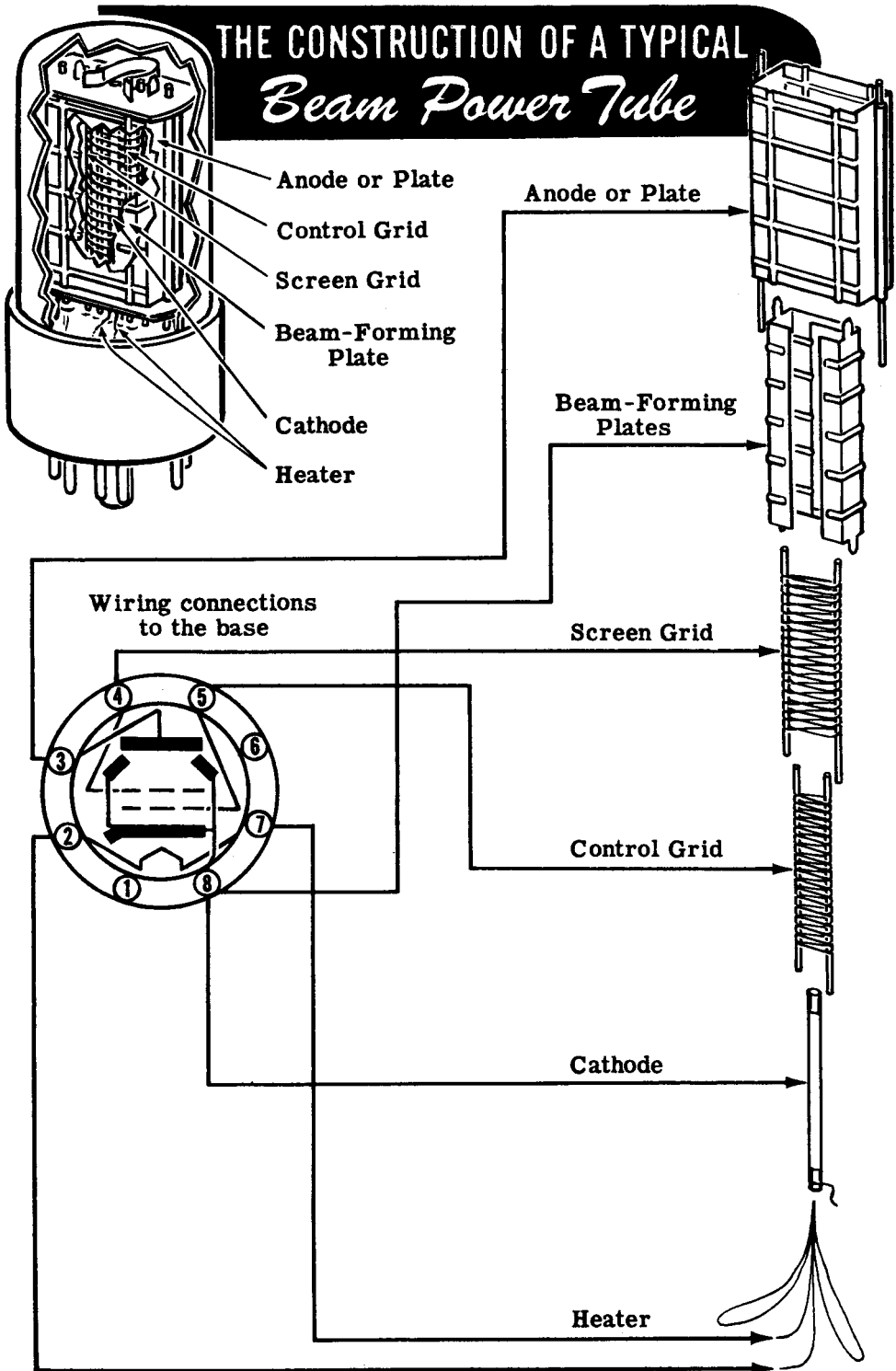

THE TETRODE AND THE PENTODE

Summary of Pentode Operation

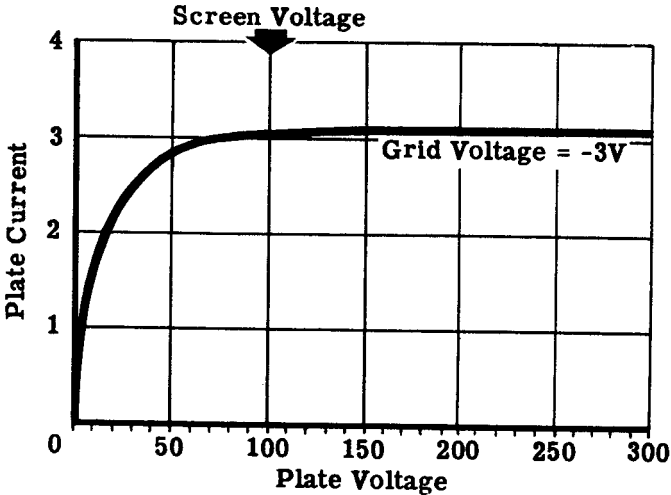

Curve No. 1: Over a wide range of plate voltages, the pentode plate current does not vary. But this is not saturation; in the next curve you will see that it is possible to draw more current than this. The reason the current doesn't vary over this range of values is that the screen shields the plate from the cathode's space charge.

At low plate voltages, however, the plate current does vary. Although the total tube current remains the same, many more electrons are attracted to the screen, which is now more positive than the plate is.

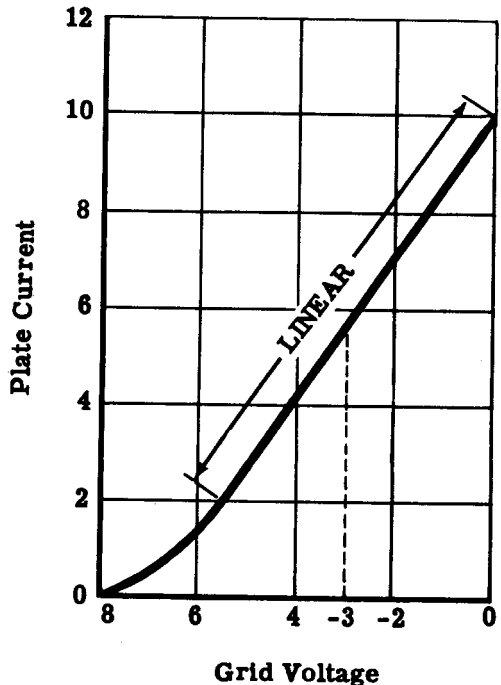

Curve No. 2: Here, you see that the control grid in a pentode controls current in the same way as it did in a triode. Normal grid bias for this particular pentode is about -3 volts.

The fact that the current rises considerably above 3 ma. in this test shows that 3 ma. is not the limit of cathode emission. Therefore, the flattened portion you saw in the first curve could not have been saturation.

THE TETRODE AND THE PENTODE

Summary of Pentode Operation (continued)

Curves No. 3 and 4: With the same value of load resistor in each, you can obtain larger amplifications with the pentode than with the triode.

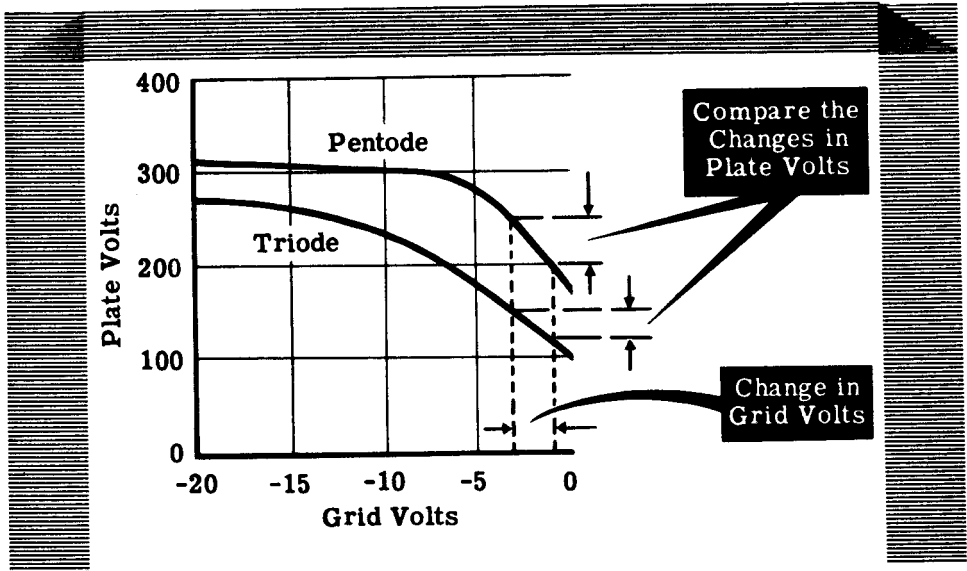

With a larger load resistor in the pentode circuit, larger amplification is obtained. This happens because the grid voltage, and only the grid voltage, can produce a change of current. This current will flow through the load resistor—the larger the resistor, the larger the voltage change.

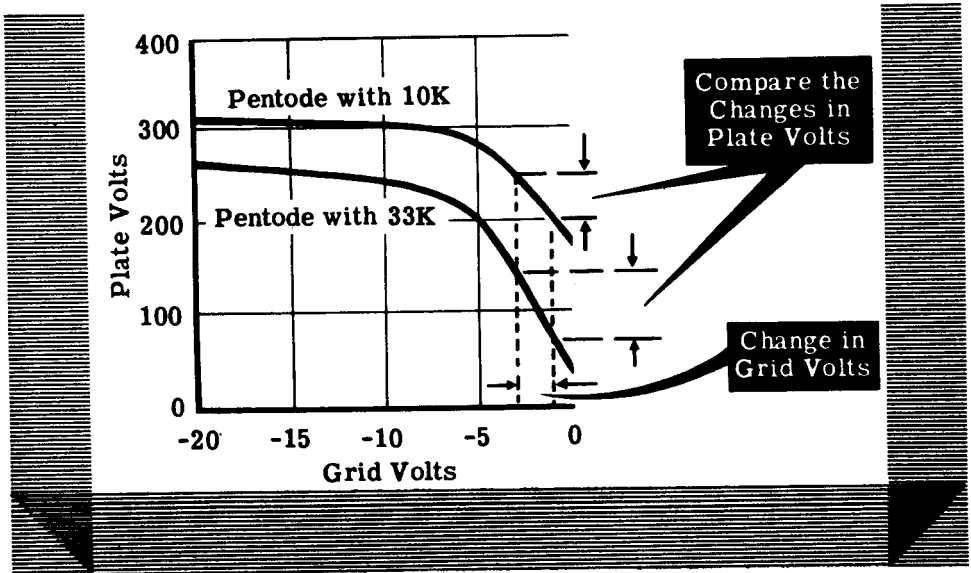

THE TETRODE AND THE PENTODE

Review of Tetrodes and Pentodes

THE TETRODE — A tube having a screen grid to reduce plate-to-control grid capacitance. It is rarely used today, but was a step in the development of the pentode.

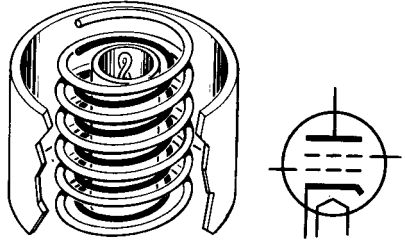

THE PENTODE — A tube which uses a suppressor grid between the screen grid and plate to reduce the effect of secondary emission. It has greater amplification than the triode.

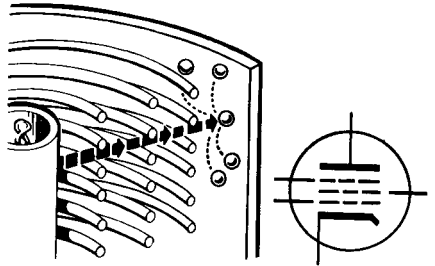

THE BEAM POWER TUBE — Tube using beam-forming plates instead of the suppressor to reduce the effects of secondary emission. Its power output is greater, for a given amount of cathode emission, than that of a pentode.

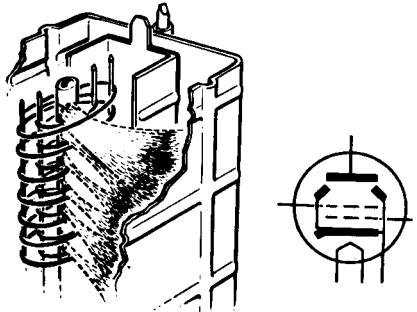

PENTODE CIRCUIT — A circuit providing proper operating voltages for control grid, screen grid and suppressor grid.

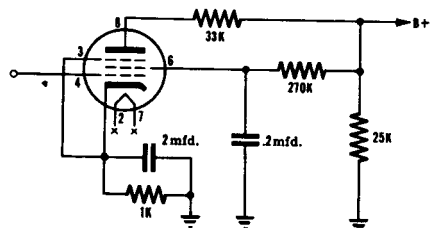

THE SINGLE-STAGE AMPLIFIER

A Typical Amplifier Stage

You are already familiar with the purposes of most of the components that will be used in this amplifier circuit. The 1-meg. resistor in the grid circuit is there to prevent any negative charge from accumulating on the grid. The 12K resistor and the 25-mfd. capacitor in the cathode circuit are the bias components. The 270K resistor in the plate circuit is the load resistor. The .01-mfd. capacitor and the 1-meg. resistor will be the RC coupling to the next stage of amplification.

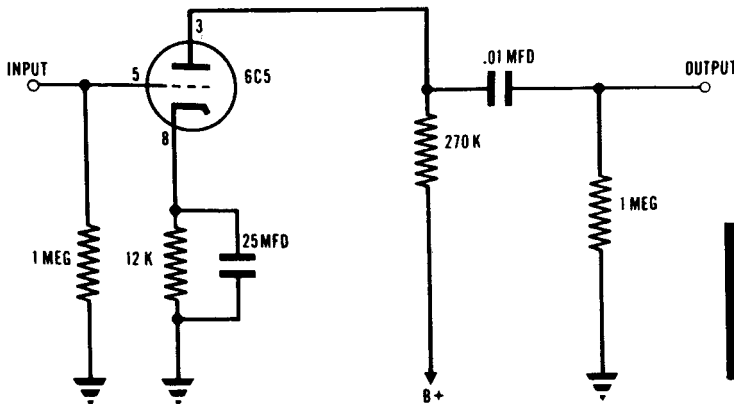

**TYPICAL
AMPLIFIER
STAGE**

The circuit shown below has two additional components. You will notice that the plate load resistor is connected to B+ through a 25K resistor. This resistor and the 8-mfd. capacitor make up a special filter circuit called a decoupling filter. If some form of undesired coupling exists between the various circuits of a multistage amplifier, we say that we have feedback. This feedback causes the amplifier to generate a low frequency audio signal which sounds like a motorboat when heard from the loudspeaker. It is the job of the decoupling filter to eliminate the feedback and the resultant motorboating.

Typical Amplifier Stage with **DECOUPLING FILTER**

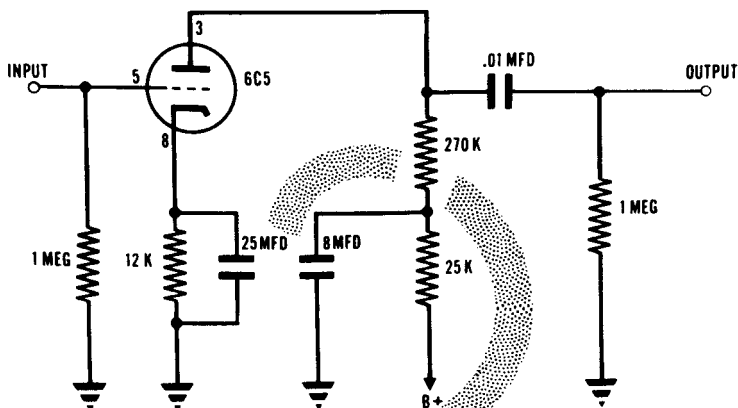

THE SINGLE-STAGE AMPLIFIER

The Decoupling Filter

Coupling may exist between circuits operating at the same frequency and having common impedance. If an amplifier contains several stages of amplification, all those stages will be supplied with plate voltage from a single source of DC power. The plate currents of all the amplifier tubes must flow through this power supply. Therefore, the internal resistance of the power supply (produced by the choke wire, internal tube resistance, etc.), will act as a common impedance for all the amplifier circuits.

When a signal is applied to the amplifier, the plate currents of all the tubes will vary in accordance with the signal. In addition to the DC flowing through the common power supply, we now have the AC components of all the plate currents flowing through the common impedance. Some of these currents will be in phase with each other and some will be 180 degrees out of phase. It is the currents which are in phase that cause the most trouble.

The in-phase currents add to one another and produce voltage variations across the common impedance which "feeds back" the variations from one stage to another. The overall effect of this is a sound in the loudspeaker which resembles the purring of an outboard motor. That is why this trouble in an amplifier is called "motorboating."

On the next sheet you will see how the decoupling filter eliminates feedback and motorboating.

FEEDBACK IN A THREE STAGE AMPLIFIER

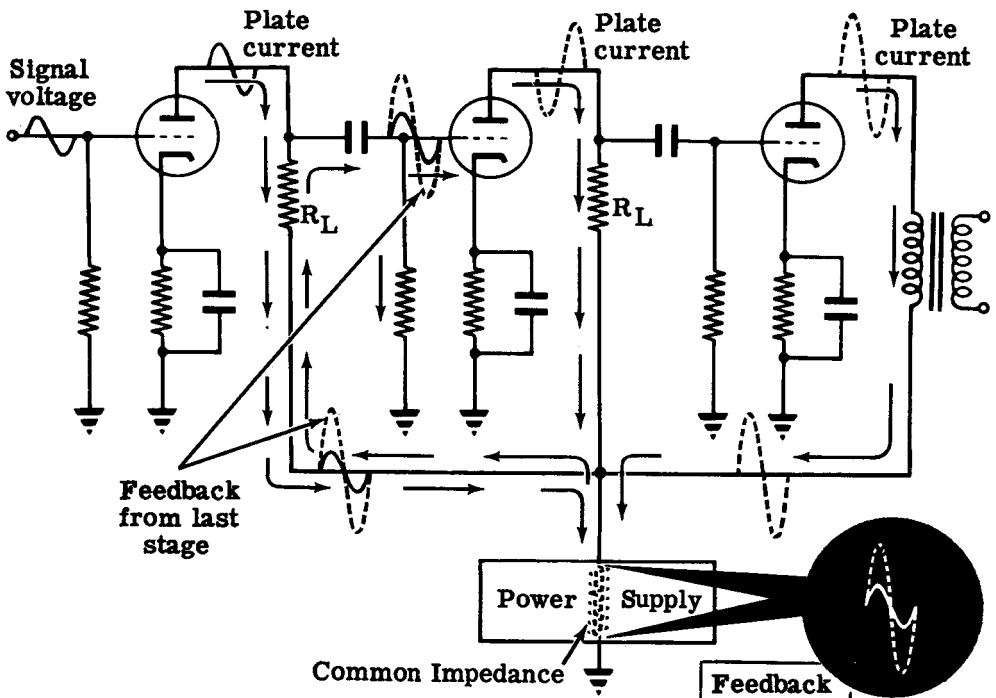

THE SINGLE-STAGE AMPLIFIER

The Decoupling Filter (continued)

If the AC components of plate current could be kept from flowing through the common impedance of the power supply, then the feedback that originates there would be eliminated. The decoupling filter's job is to provide a path of low reactance around the power supply and a path of high resistance to AC current flow through the power supply. Because of this very little AC current will flow through the power supply and its common impedance, thereby eliminating feedback.

The value of the decoupling capacitor must be high enough so that its reactance is much less than the total resistance of the decoupling resistor and the common impedance of the power supply. In an amplifier of the type shown, the value of the decoupling resistor is generally about one fifth the value of the plate load resistor R_L . The value of the decoupling capacitor varies from about 0.25 to 8 mfd.

The action of the decoupling filter is to isolate each stage from the power supply common impedance. The way the filter does this is shown below.

Decoupling Filters ISOLATE AMPLIFIER STAGES AND ELIMINATE FEEDBACK

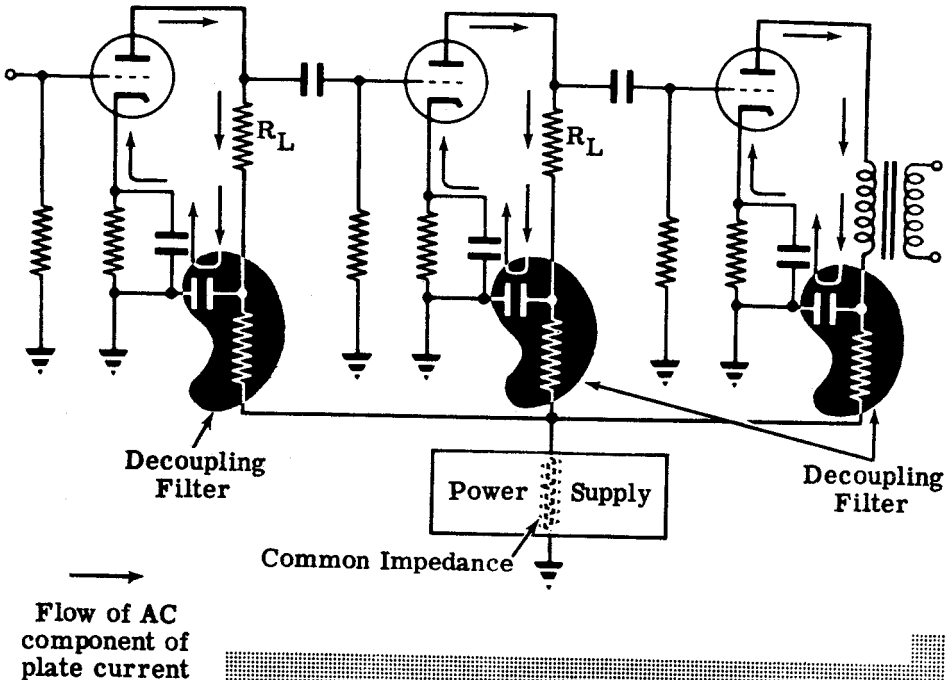

THE TWO-STAGE RC COUPLED AMPLIFIER

How to Increase Gain

If you need a voltage gain of 200 or less in an amplifier, one tube would be enough. However, very often a gain of 10,000 or 100,000 or even higher is required, and there is no way to make a single vacuum tube give you that much amplification. In order to increase the amplification, several tubes are needed.

These tubes are connected so that the voltage change from the plate of one amplifier tube is fed into the grid of a second tube; the voltage change from the plate of the second tube is fed into the grid of a third tube and so forth. If the amplification of each tube is 50, the signal input to the second tube will be 50 times greater than the signal fed into the first. The output of the second tube will be 50 times greater than its input or 2,500 times greater than the original signal. The third tube will amplify the output of the second tube 50 times so that its output is $50 \times 2,500$ times larger than the input to the first tube. Thus, the amplifier using three tubes, each with a gain of 50, has an overall gain of 125,000!

$$50 \times 50 \times 50 = 125,000$$

If the voltage change applied to the input of this amplifier is one ten-thousandth of a volt, the voltage change on the plate of the third tube will be twelve and a half volts.

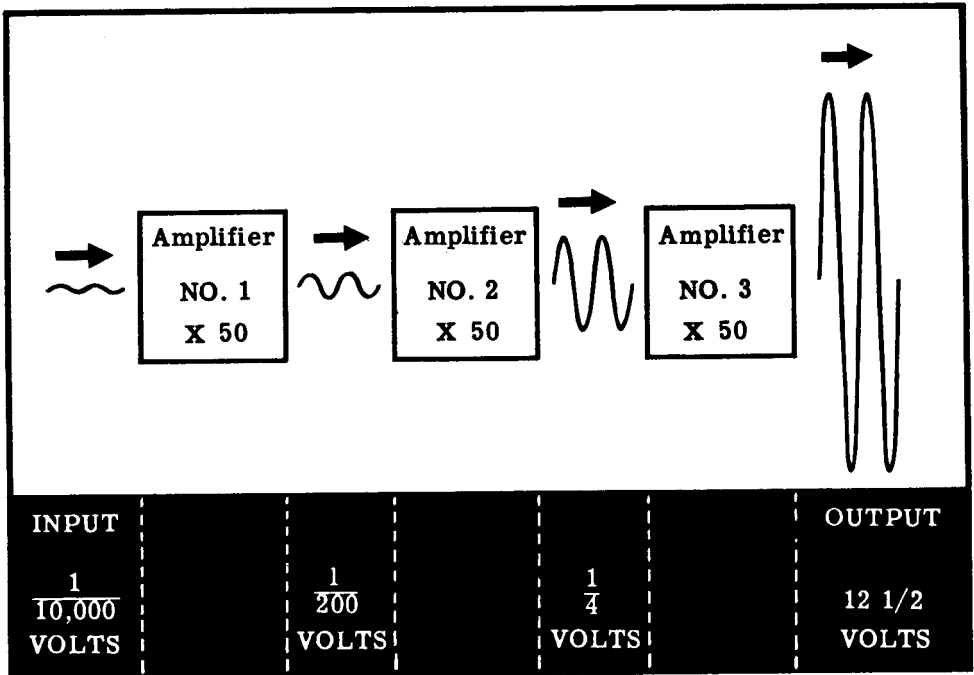

Since nearly all amplifiers require more amplification (gain) than can be achieved with only one tube, multi-stage amplifiers of this type are very common in all types of electronic equipment.

THE TWO-STAGE RC COUPLED AMPLIFIER

Coupling of Amplifier Stages

When several tubes are used in an amplifier, each tube together with its circuit is called a "stage" of amplification. There are several methods of connecting the output of one stage to the input of the next stage. You remember that the output of an amplifier tube is taken from the plate and the input is placed on the grid. Since the DC operating voltages of a plate and of a grid are so very different, a simple wire leading from one plate to the next grid cannot be used. The connection (or "coupling" as it is more commonly called) between two stages must, in some way, prevent the DC plate voltage from getting to the next grid. At the same time, the coupling must permit the plate voltage variations—AC—to become the input of the next stage.

There are two very common and very simple ways of doing this. One way is by using a transformer, the other by using a capacitor and a resistor.

Transformer coupling is accomplished by connecting the primary winding between the plate of the first tube and B+, and the secondary winding between the grid of the second tube and ground. By so doing, the B+ voltage is isolated in the plate circuit while only the AC is transferred to the grid.

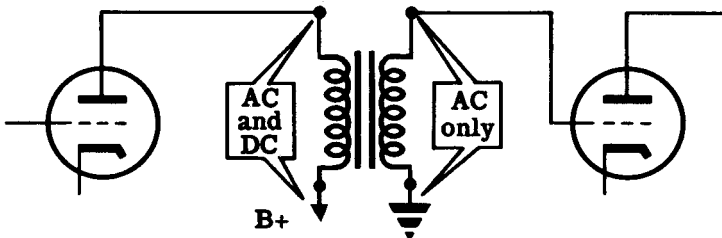

TRANSFORMER COUPLING

The use of the capacitor in coupling circuits is very widespread, the most common circuit being the RC (or resistance-capacitor) circuit. In your study of vacuum tubes, you learned that current variations in the load resistor cause the voltage at the plate to vary above and below a steady value. The coupling capacitor will charge to that steady voltage and, as the plate voltage rises above and falls below that value, the capacitor will charge and discharge slightly, causing an AC current to flow in the grid resistor. The voltage across the grid resistor therefore is AC and is the input to the next stage.

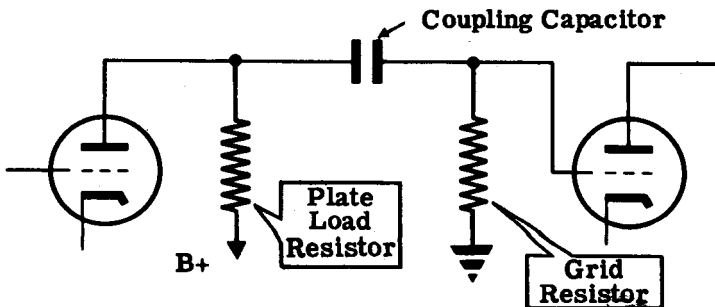

RC COUPLING

THE TWO-STAGE RC COUPLED AMPLIFIER

Characteristics of the Two-Stage Amplifier

The two-stage amplifier can be compared to two step-up transformers with the secondary of one connected to the primary of the other. For example, if two transformers which have a step-up ratio of 1 to 3 are connected in this manner, an AC voltage applied to the primary of the first transformer would be amplified 9 times by the combination. This example is illustrated below.

OBTAINING VOLTAGE AMPLIFICATION WITH A TRANSFORMER AND VACUUM AMPLIFIER

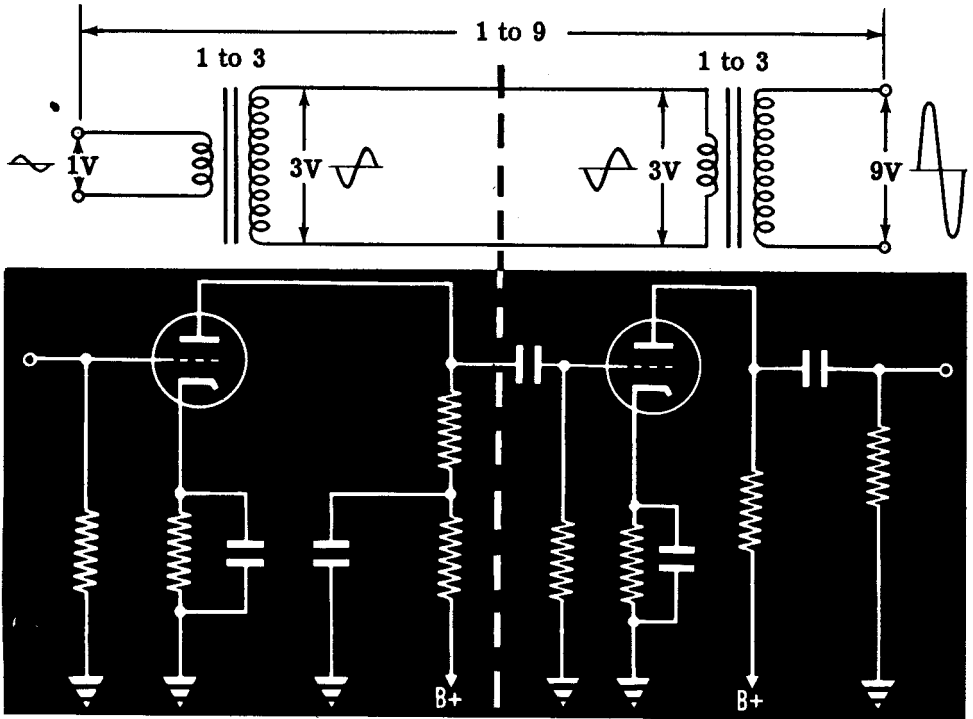

You may conclude from this that it would be a good idea to forget all about using vacuum tubes as amplifiers and use transformers instead. This is not possible because transformers with very high step up ratios would have to be used if they were to deliver a high amplification. Transformers of this type are impractical and even if they were used would not amplify all the audio frequencies the same amount. The higher audio frequencies (around 10,000 cycles) and the lower audio frequencies (around 100 cycles) would not be amplified as much as the middle frequencies. This would result in a signal output that is not a true representation of the original signal applied to the transformers.

Amplifiers using vacuum tubes can deliver much higher amounts of amplification, are lighter in weight, less costly and take up less space. On the next sheet you will see how a multistage vacuum tube amplifier compares to the transformer combination explained here.

THE TWO-STAGE RC COUPLED AMPLIFIER

Characteristics of the Two-Stage Amplifier (continued)

When the output of one amplifier is fed to the input of another, the two amplifiers are said to be connected in cascade. An amplifier arrangement of this type is shown below.

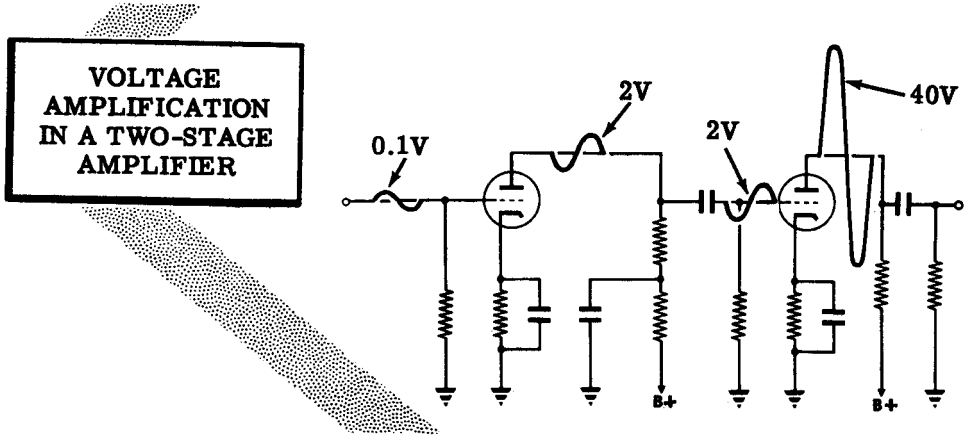

Suppose each amplifier stage can deliver an amplification of 20. If a 0.1 volt AC signal is applied to the grid of the first stage, the output of this stage will be $20 \times 0.1 = 2\text{V}$. Since the output of the first stage is connected to the input of the next stage there will be 2 volts AC on the grid of the second stage. The second stage amplifies the signal 20 times and produces an output voltage of $20 \times 2 = 40\text{V}$.

The overall amplification of the two stages is the product of the individual amplifications, that is, the gain of the first stage \times the gain of the second stage. In this case the overall amplification is $20 \times 20 = 400$. You can check this by multiplying the input voltage of 0.1 volts by the overall amplification. The result will be the output voltage ($400 \times 0.1 = 40\text{V}$).

If another stage is added to the output of the two-stage amplifier, 40 volts would be applied to its grid. In most cases, this signal would be too large for the tube to handle. The result is that the grid would be driven into the positive region and the cut-off region, and distortion produced. A potentiometer in the grid circuit of one of the amplifier tubes could be used to reduce the output signal so that the following stages would not be overdriven. This potentiometer is commonly referred to as the volume control.

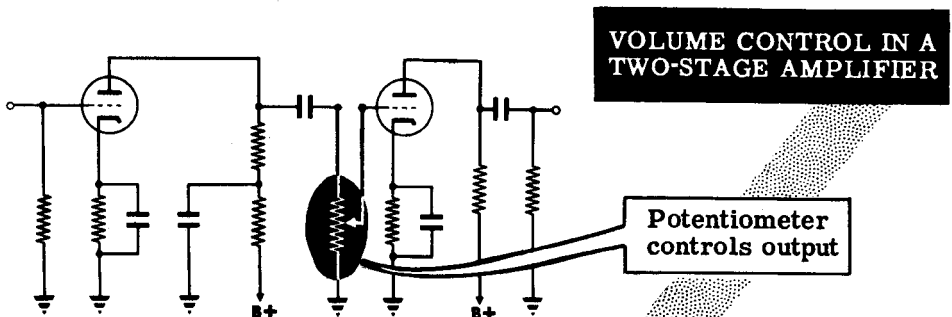

THE TWO-STAGE RC COUPLED AMPLIFIER

Frequency Response

Frequency response is a term applied to describe the effect in which some frequencies are amplified more than others. In actual practice, all amplifiers have a range over which they are designed to operate; above and below this range the signal output drops off rapidly. If an audio amplifier cannot amplify all the frequencies of the human voice by an equal amount, there is a loss of voice quality.

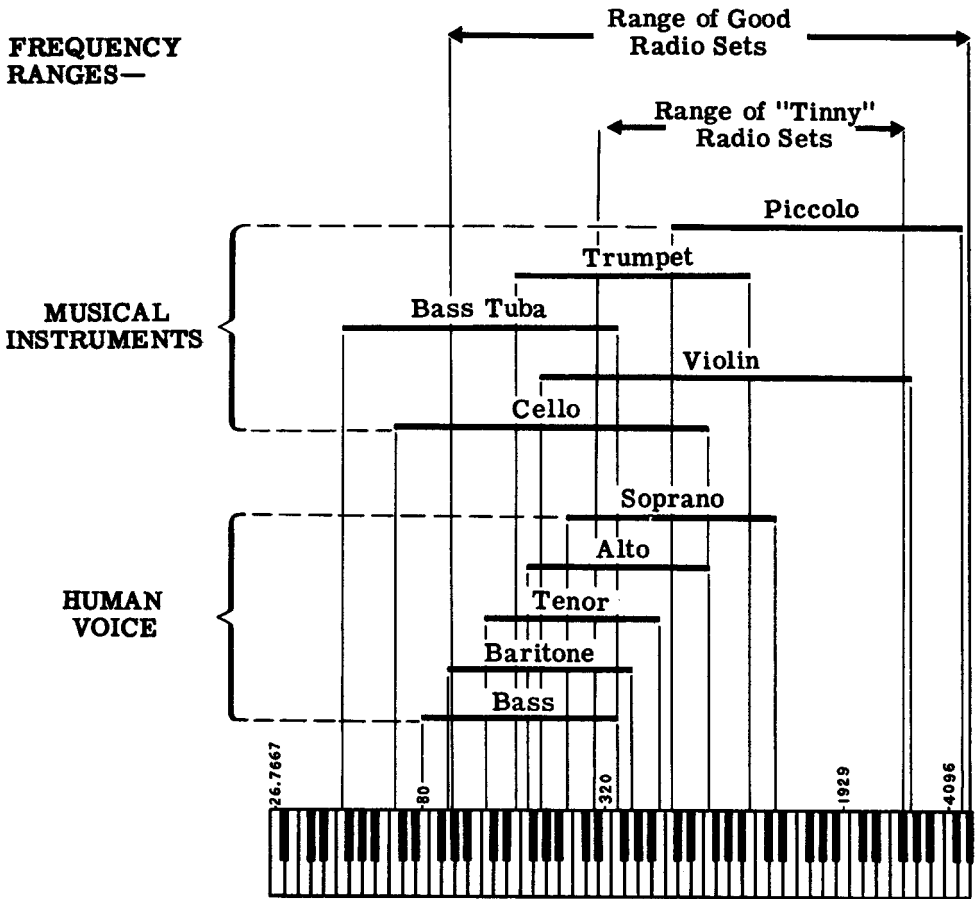

It is possible for this frequency distortion to be so great that the voice message cannot be understood. For this reason you should learn to measure the frequency response of your amplifier and see how good it actually is. A modern commercial amplifier designed for music amplification will have an equal gain from 30 - 15,000 cycles. A range as wide as this is hardly necessary for good amplification of voice signals.

THE TWO-STAGE RC COUPLED AMPLIFIER

Frequency Response (continued)

Even though the RC-coupled amplifier is well suited for the job of amplifying a wide range of frequencies, there are still causes for a drop in gain at high and low frequencies. Let's take a quick look at these causes:

At low frequencies the coupling capacitor and the grid resistor make up a voltage divider across the signal voltage input. As a result, only part of the signal gets to the grid of the amplifier tube. Just how much of the signal gets to the grid depends upon the reactance of the coupling capacitor as compared to the resistance of the grid resistor.

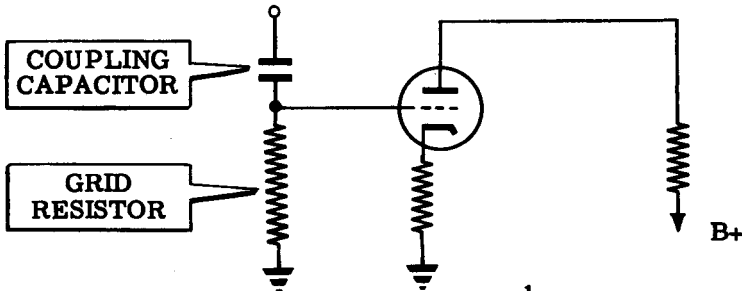

Due to the fact that capacitive reactance ($X_C = \frac{1}{2\pi fC}$) grows larger as frequency decreases, the amount of signal voltage lost across the capacitor increases at low frequencies. You can see that the signal voltage across the grid resistor becomes less and less as the frequency decreases. To reduce this loss of signal, the reactance of the coupling capacitor should be small with respect to the grid resistor at the lowest frequency to be amplified. This means that either the grid resistor or the coupling capacitor should be as large as possible. (If C increases, X_C decreases.)

However, if the coupling capacitor is made too large, there will be increased leakage through it from B+. This leakage will place a positive voltage on the grid and thereby disturb the amplifier operation. Luckily, we never need coupling capacitors that are so large that leakage becomes a problem. In fact, because of size and weight considerations, it is common to use a smaller coupling capacitor than is needed. Thus, low frequency response is sacrificed slightly so as not to bring about more serious problems. At high frequencies the coupling capacitor is no longer a cause of trouble, since its reactance is low compared to the grid leak resistor.

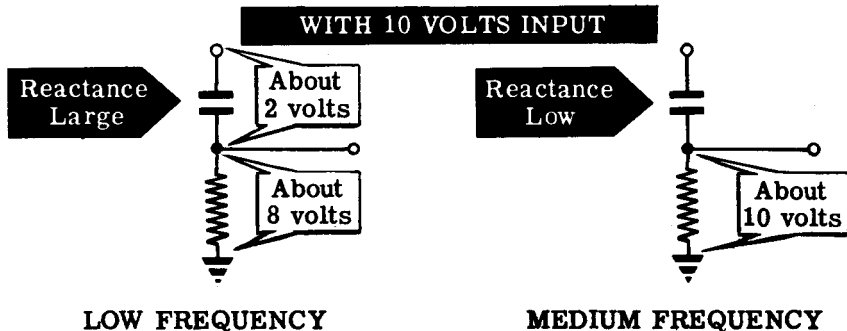

THE TWO-STAGE RC COUPLED AMPLIFIER

Frequency Response (continued)

At high frequencies, too, there is an effect that causes a loss of amplification. This loss is due to total stray capacitance that exists between the grid and ground. This total capacitance consists of the plate-to-cathode interelectrode capacitance of the tube from which the signal is taken, the grid-to-cathode capacitance of the tube to which the signal is brought, and the stray capacitances between the signal-carrying wires and the chassis.

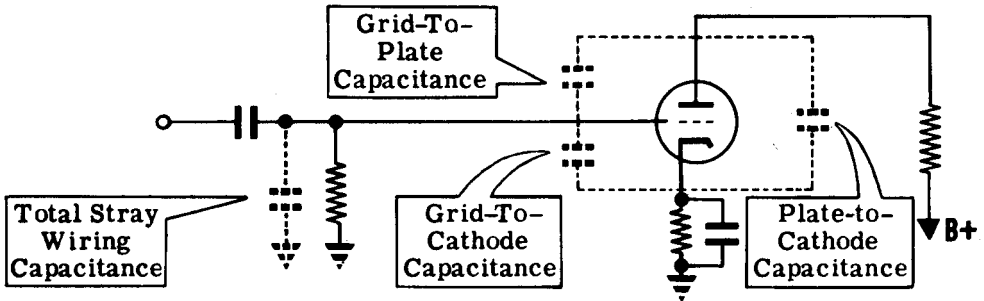

The effect of this total capacitance is to shunt the grid leak resistor. At low and medium frequencies the reactance of this small capacitance is high and therefore it does not disturb the operation of the circuit. At high frequencies, the reactance drops and effectively decreases the impedance between grid and ground. The signal appearing between grid and ground decreases as the impedance between grid and ground decreases.

Thus, the gain at high frequencies is less than at medium frequencies because of the shunting effects of the total stray and interelectrode capacitances. It is important to note that a low gain in itself is not bad; if the same gain existed for all frequencies, there would be no problem. Difficulties with frequency response are encountered only when there are unequal gains at different frequencies.

WITH 10 VOLTS INPUT

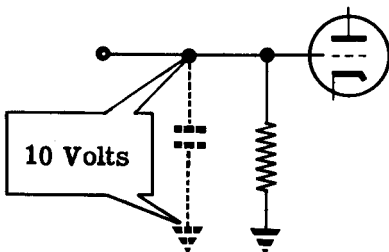

AT MEDIUM FREQUENCIES

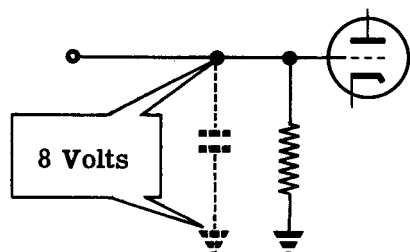

AT HIGH FREQUENCIES

The solution to the problem of loss of gain at high frequencies is to use special amplifier tubes with very low values of input and output capacitances, to use special wiring techniques to reduce the stray capacitance between the wire and ground, and to use lower values of resistors in the RC coupling. These methods increase the frequency at which the shunting effect becomes noticeable.

THE TWO-STAGE RC COUPLED AMPLIFIER

The Frequency Response Curve

The usual way that the frequency response of an amplifier is shown is with a frequency response curve. In this curve, a plot is made of the gain at each frequency; the highest gain is 100 percent (or sometimes 1.00) and any gain below that is figured as a certain percent of maximum—such as 75 percent, 25 percent, and so forth.

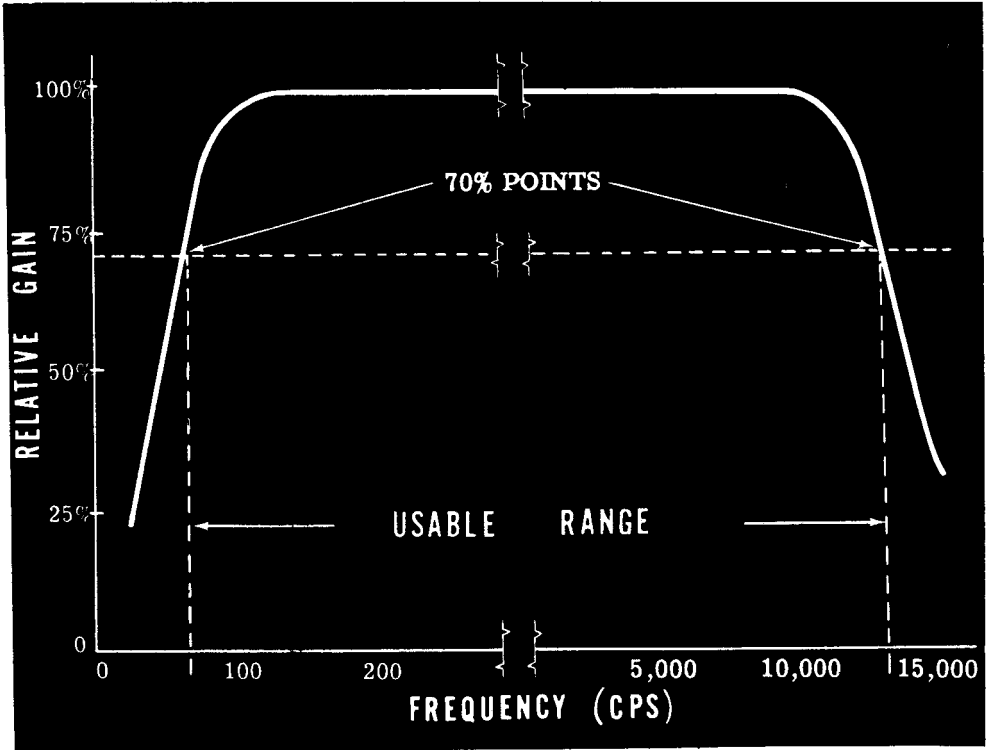

The general shape of the curve shows a flat region (plateau) between the ends of the curve. This means that the gain does not vary by very much as the frequency changes from the low end to the high end of this portion. This represents the usable frequency range of the amplifier.

On either side of this flat portion, there is a rapid falling-off of the curve. This means that the gains at these frequencies (both low and high) are not as high as the gain at the middle frequencies. In a speaker, the ear can detect these lowered gains if they are about 70 percent of maximum or below. Therefore, it is the 70-percent points on each end of the curve that determine the usable range.

As you remember from the previous discussions on frequency response, the reason for the decreased gain at the low end of the band was the fact that the coupling capacitor and the grid leak resistor form a voltage divider. The reactance of the coupling capacitor increases at the low frequencies, and the voltage across the resistor decreases. At the high end, the loss of gain is due to the shunting effect of the stray capacitances between grid and ground. At the middle frequencies, neither effect is noticeable and the gain does not vary by any appreciable amount.

THE TWO-STAGE RC COUPLED AMPLIFIER

Review of the Two-Stage Amplifier

RC COUPLING — When two or more stages are used in an amplifier, the AC plate voltage of each stage is fed to the grid of the next stage through the coupling capacitor and resistors.

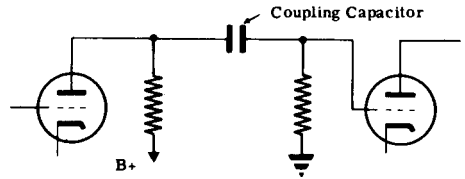

VOLTAGE GAIN — The total amplification of a two-stage (or multistage) amplifier is the product of the amplifications of each stage. The ratio of the output voltage of final stage to the input voltage of first stage is called the gain of the amplifier.

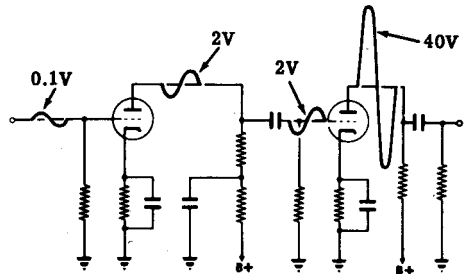

AMPLIFICATION LOSSES — At low frequencies the high reactance of the coupling capacitor reduces voltage gain; at high frequencies stray capacitance causes loss of voltage gain.

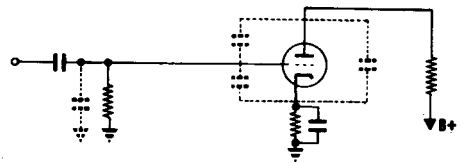

FREQUENCY RESPONSE — A measure of the ability of an amplifier to amplify AC signals of various frequencies by the same amount.

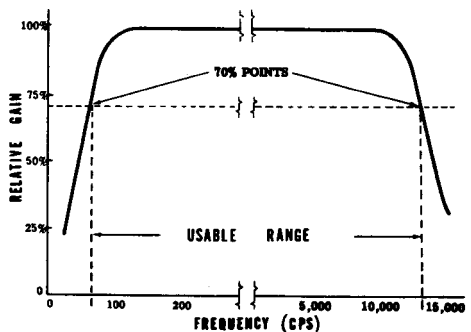

THE TRANSFORMER-COUPLED AMPLIFIER

Transformer Coupling

A transformer-coupled amplifier is an amplifier that makes use of transformer coupling instead of RC coupling between the stages. This method is most often used to couple an amplifier to its load, but it also may be used for interstage coupling. One advantage of using a transformer is that the secondary winding may have more turns than the primary winding, resulting in a voltage step-up. In addition, there is no sizable voltage drop in voltage at the plate of the amplifier tube as in the case of using a plate load resistor, and no coupling condenser is required. In transformer coupling the maximum gain is $\mu \times N$ where "N" is the ratio between the number of turns in the primary and secondary windings and μ is the amplification factor of the tube. In resistance coupling the maximum possible gain is only the μ of the tube.

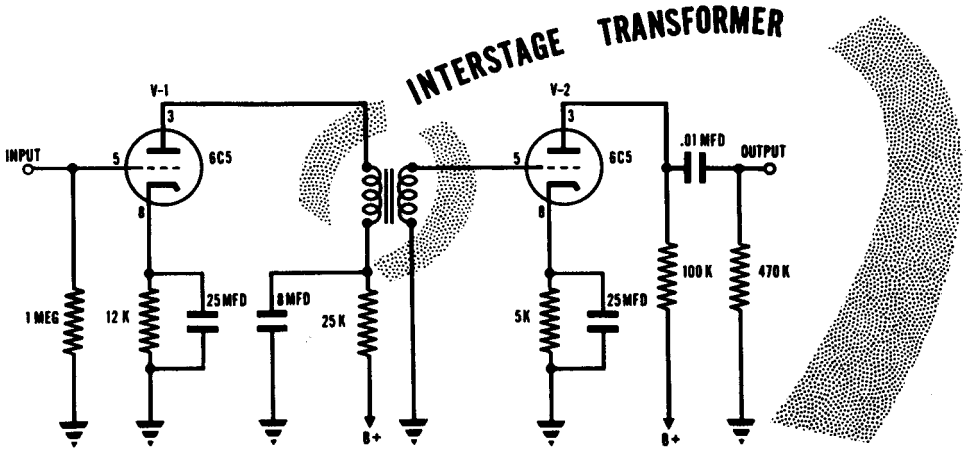

The reasons why transformer coupling is not widely used are, first, that a transformer usually has a poorer frequency response than an RC network. Modern high gain tubes cancel any advantages that the transformer has in voltage amplification. In spite of improvements in the design of interstage transformers, the trend is toward using high gain vacuum tubes with RC rather than transformer coupling between the stages of the amplifier.

There are many applications in which transformer stages have a particular advantage. Some of these applications include: High output for limited power supply voltage, impedance matching between low and high impedance lines and push-pull applications. In push-pull amplifiers a transformer is more readily adaptable than resistance coupling, and unlike an RC coupling, it places a low DC resistance in the grid circuit of the following amplifier under conditions where a low DC resistance is essential.

INTERSTAGE TRANSFORMERS

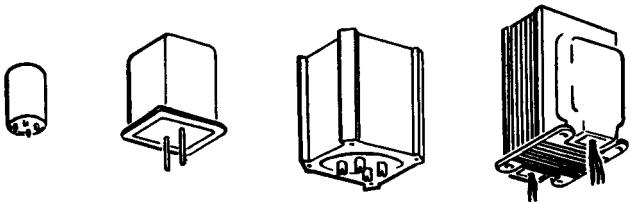

THE TRANSFORMER-COUPLED AMPLIFIER

Transformer Coupling (continued)

The main disadvantage of transformer coupling is that the impedance of the primary and secondary windings is not constant, but changes if the frequency of the signal is changed. If the frequency increases, the impedance increases and when the frequency decreases, the impedance decreases.

Look at the transformer in the schematic on the previous sheet. Suppose the primary winding has an inductance of 10 henries. At the low frequency of 100 cycles it will have an inductive reactance of—

$$X_L = 2\pi fL = 6.28 \times 100 \times 10 = 6,280 \text{ ohms}$$

At the mid-frequency of 1000 cycles, the inductive reactance will be—

$$X_L = 2\pi fL = 6.28 \times 1000 \times 10 = 62,800 \text{ ohms}$$

and at 10,000 cycles, it would be—

$$X_L = 2\pi fL = 6.28 \times 10,000 \times 10 = 628,000 \text{ ohms}$$

Since the inductive reactance of the primary is used as the plate load impedance of the triode amplifier, the inequality of reactance to AC signals of different frequencies will produce non-uniform amplification over the audio frequency range. A graph of the amplification of a transformer-coupled amplifier is shown below. Compare the graph of the transformer-coupled amplifier with that of the RC-coupled amplifier. Notice how much more uniform the amplification of the RC-coupled amplifier is.

THE AMPLIFICATION OF AN RC-COUPLED AMPLIFIER AND A TRANSFORMER-COUPLED AMPLIFIER AT AUDIO FREQUENCIES

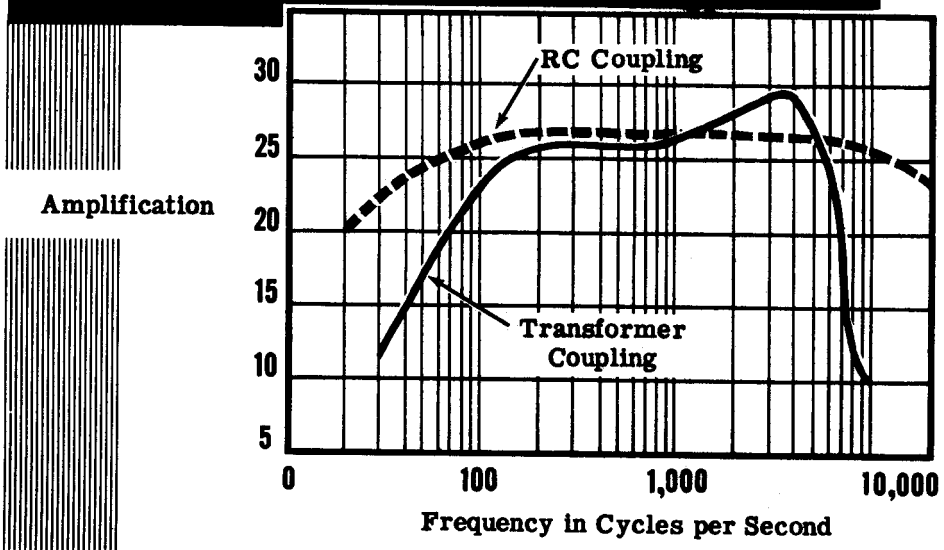

THE TRANSFORMER-COUPLED AMPLIFIER

Characteristics of the Transformer-Coupled Amplifier

The transformer-coupled amplifier shown below is typical of most amplifiers of this type. The amplifier has two stages coupled by an inter-stage audio transformer that has a 3 to 1 step-up ratio. The input stage uses a 6C5 triode V-1. The amplified output voltage of this tube is stepped up 3 times by the transformer and then fed to the grid of another 6C5 triode V-2. The second triode amplifies the signal still further and its amplified output appears across the 100K plate load resistor. The 0.01 mfd coupling capacitor blocks the DC but presents a low reactance to the AC component at the plate of V-2. Therefore, only the AC component of the plate voltage at V-2 appears across the 470K resistor. Normally, the 470K resistor would be the grid resistor of the next stage so that the signal across the resistor could be amplified further.

TRANSFORMER-COUPLED AMPLIFIER

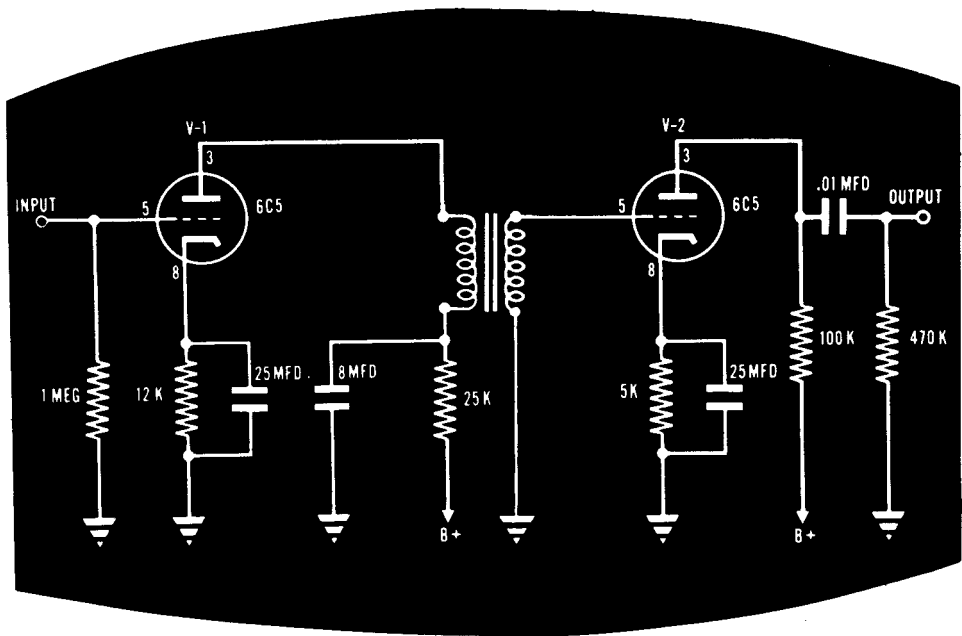

On the next sheet, a signal will be traced through the transformer-coupled amplifier and you will see how amplification occurs in this circuit.

THE TRANSFORMER-COUPLED AMPLIFIER

Characteristics of the Transformer-Coupled Amplifier (continued)

The amplification that can be expected from a transformer-coupled amplifier stage is approximately equal to the amplification factor (μ) of the tube times the turns ratio of the transformer (N). Amplification = $\mu \times N$. In this case, a 6C5 tube is used which has a μ of 20. The transformer has a step-up turns ratio of 3 to 1. Therefore, we can expect an amplification or gain of $-\mu \times N = 20 \times 3 = 60$.

Suppose a 0.01 volt AC signal is applied to the grid of V-1. From the illustration you can see that the output voltage of the 6C5 appears across the primary winding of the transformer and is amplified μ times ($20 \times .01 = 0.2V$). The transformer steps up the primary voltage 3 more times so that the secondary voltage is $3 \times 0.2 = 0.6V$.

It was stated that the gain of this stage is equal to μN or 60. Let us see if this checks. The grid signal is 0.01V. If we multiply this grid voltage by the gain we should get the voltage at the secondary of the transformer, or 0.6V. Multiply $60 \times 0.01 = 0.6V$ and you can see that this relationship holds.

VOLTAGE AMPLIFICATION IN A TRANSFORMER-COUPLED AMPLIFIER

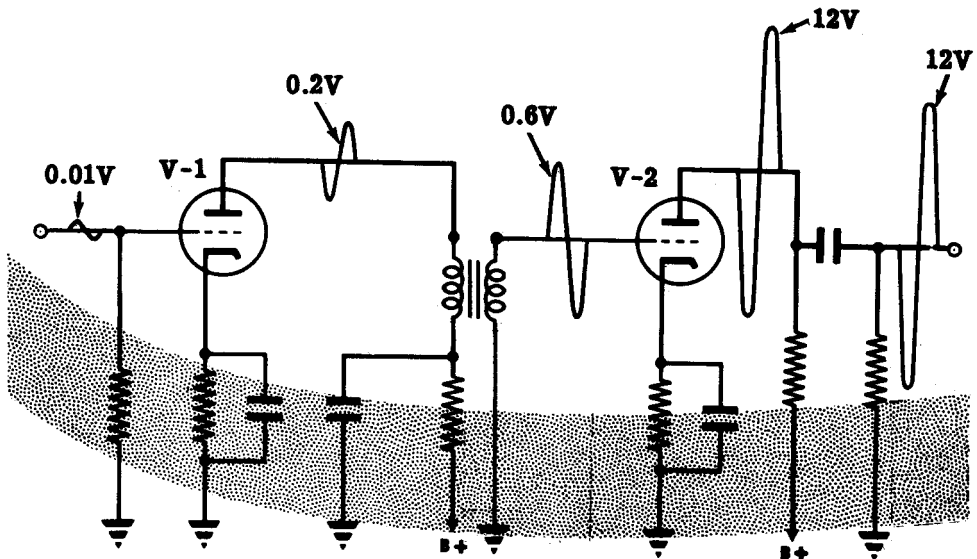

The voltage across the secondary of the transformer (0.6V) is now applied to the grid of V-2. If we assume that the gain of V-2 is equal to μ , then V-2 will amplify this signal 20 times. Therefore, the output voltage at the plate of V-2 will be $-20 \times 0.6 = 12V$.

The total gain is determined by multiplying the individual stage gains together. The gain of V-1 and the transformer is 60 and the gain of V-2 is 20. The overall gain is $-60 \times 20 = 1200$.

Checking this result, the input to V-1 times the overall gain should give us the output voltage of V-2— $1200 \times 0.01 = 12V$ which is correct.

THE AUDIO POWER AMPLIFIER

Characteristics of Audio Power Amplifiers

Up to this time you have been learning about audio amplifiers that are primarily designed to amplify the signal voltage up to many times the original input voltage. Now you will learn about power amplifiers. In a voltage amplifier the varying signal current in the plate circuit is used only in the production of a voltage to be applied to the grid of a following stage. The plate current is usually relatively small.

On the other hand, a power amplifier must supply a heavy signal current into a load impedance which usually lies in the range of 2000 to 20,000 ohms. Power amplifiers are used to drive power-consuming circuits or devices, such as loudspeakers, certain portions of transmitters and large amplifier stages whose grids require power from the preceding stage.

One use of audio power amplifiers is, of course, to produce a powerful audio signal. The radioman will find it used as the output stage of his receivers, and also in equipment which injects voice signals into transmitters. The sound man will find this circuit in almost every piece of his sound equipment. The sonarman will find audio power amplifiers used to produce the signal to drive not only a loudspeaker but also the underwater sound element called a transducer. Audio power amplifiers are also used in equipments which rotate radar antennas, sonar transducers and ship's guns.

POWER AMPLIFIERS

Are Used in Many Types of
Equipment

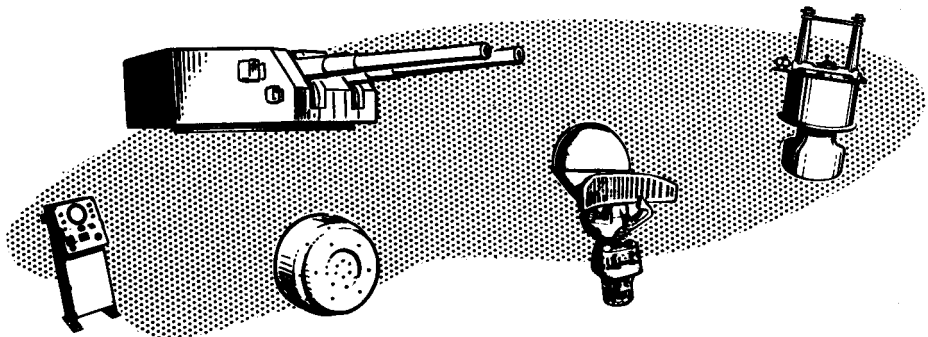

THE AUDIO POWER AMPLIFIER

Characteristics of Audio Power Amplifiers (continued)

You have learned in the preceding topics that the main purpose of voltage amplifier circuits is to produce a large increase in signal voltage. The amplified output of the voltage amplifier will now be applied to the grid of a power amplifier stage.

In the voltage amplifier circuits the output of one voltage amplifier is connected to the grid of the next stage. No current flows in this grid circuit, therefore no power will be consumed. If current did flow in the grid circuit, the power loss in this circuit would have to be supplied by the preceding stage. In the case of an amplifier that feeds a loudspeaker, the speaker requires large amounts of AC signal current for proper operation. When current flows in a circuit, power is always consumed. The power amplifier stage must supply the power that is consumed in the loudspeaker circuit.

The tubes used in voltage amplifier circuits are generally operated as Class A while the tubes used in power amplifier circuits may be operated either as Class A, Class B or Class AB.

Triodes, pentodes and beam power tubes can be used as power amplifiers. These tubes may be operated singly, in parallel, or in push-pull. The type of operation depends upon the amount of power required of the amplifier.

Voltage amplifiers are usually operated with a high value of plate load resistance or impedance to obtain the maximum voltage output. Power amplifier tubes are operated with lower values of load impedance to obtain a large current variation and a large power output. In a power amplifier, the amount of voltage output is not important for it is the power output which is the main factor.

If large amounts of power are to be supplied by the power amplifier, it must be capable of carrying high current—much more current than a voltage amplifier.

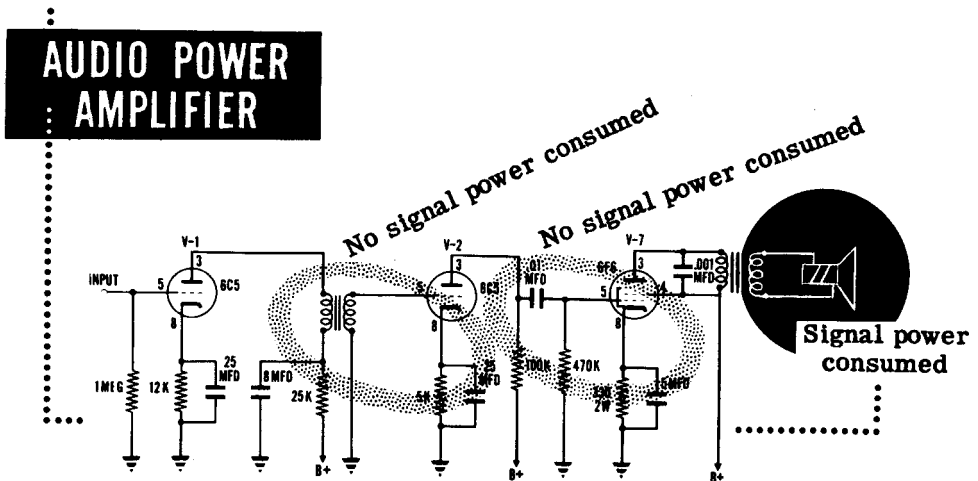

THE AUDIO POWER AMPLIFIER

Characteristics of Audio Power Amplifiers (continued)

The current that flows through the plate circuit of the power amplifier tube is made up of two parts:

1. A steady or DC component
2. A varying or AC component

The useful part of the plate current is the varying component as only variations in plate current produce sounds in the loudspeaker. The AC component of plate current flows through the primary of the output transformer along with the DC component. The DC component just produces a steady magnetic field about the primary winding and does not induce any voltage into the secondary. The AC component makes use of transformer action and induces a voltage into the secondary which is applied to the voice coil of the loudspeaker. This voltage is converted into sound by the loudspeaker.

You can see that the steady plate current does not contribute directly towards the sound output of the power amplifier circuit. This portion of the plate current does produce a power loss in the plate circuit which produces heating of the power amplifier tube and the output transformer.

AC AND DC CURRENTS

IN A POWER AMPLIFIER

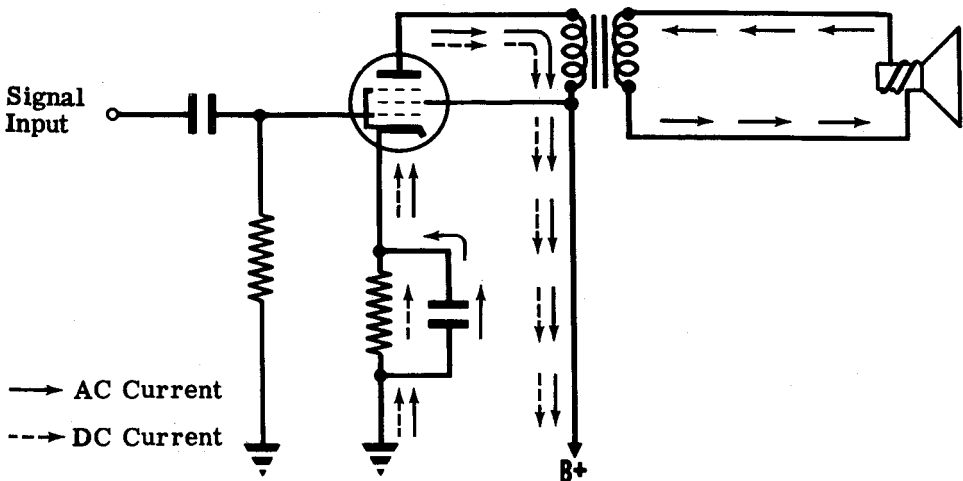

THE OUTPUT TRANSFORMER

The Job of the Output Transformer

The output transformer's job is to couple the amplified audio power from the plate of the power amplifier tube to the voice coil of the loudspeaker. In these next few sheets you will learn about the characteristics of output transformers so that you will be able to understand the importance of impedance matching. Impedance matching is necessary because the power amplifier must have a relatively high impedance plate load while the voice coil impedance is low. The output transformer matches the low impedance voice coil to the high impedance plate circuit.

Power amplifier tubes must operate into a specified value of plate load impedance for maximum power output and minimum distortion. The correct value of load impedance for a particular tube can be obtained from the tube manufacturer's references.

In a power amplifier circuit, the primary winding of the output transformer is used as the plate load impedance and it is this impedance with which we are concerned. The primary impedance is determined by the size of the load on the secondary and the turns ratio between primary and secondary. The turns ratio and the size of the secondary load impedance must be so chosen that the resultant primary impedance is the correct value for the required load impedance of the power amplifier tube.

THE *Output Transformer* IN THE AMPLIFIER CIRCUIT

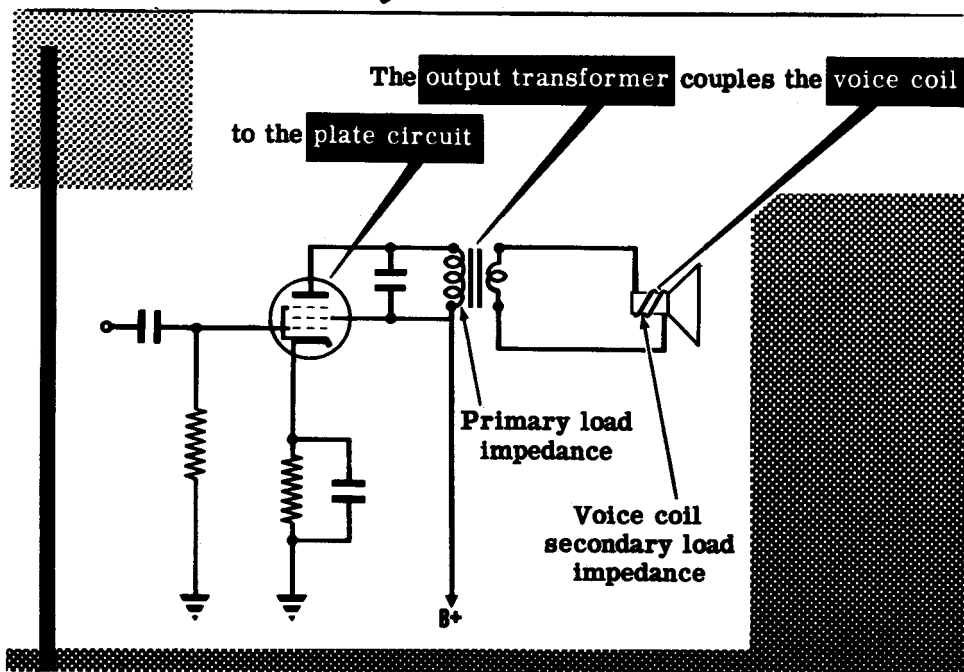

THE OUTPUT TRANSFORMER

Impedance Matching

Let us look back at some of the things you have learned up to this point. You know that a power amplifier tube must operate into a specified value of load impedance to obtain maximum power output and minimum distortion. You also know that this load impedance is actually the output transformer primary impedance, which is determined by the load on the secondary.

The secondary load is usually a loudspeaker and it is to the speaker that we wish to supply the amplified audio power. You may be thinking that it would be simpler to connect the speaker directly to the plate of the power amplifier tube but this is not possible. You recall that the plate load for the power amplifier cannot be anything but the specified value. This load is usually in the order of several thousand ohms while loudspeaker voice coil impedances are in the order of 1 to 15 ohms. If the voice coil impedance was used as the plate load, the amount of power obtainable from the amplifier would be very small to say nothing of the distortion that would result.

Therefore, we must use an impedance matching device, the output transformer, which will allow us to operate the tube into the high impedance primary and still, supply audio power to the low impedance loudspeaker voice coil.

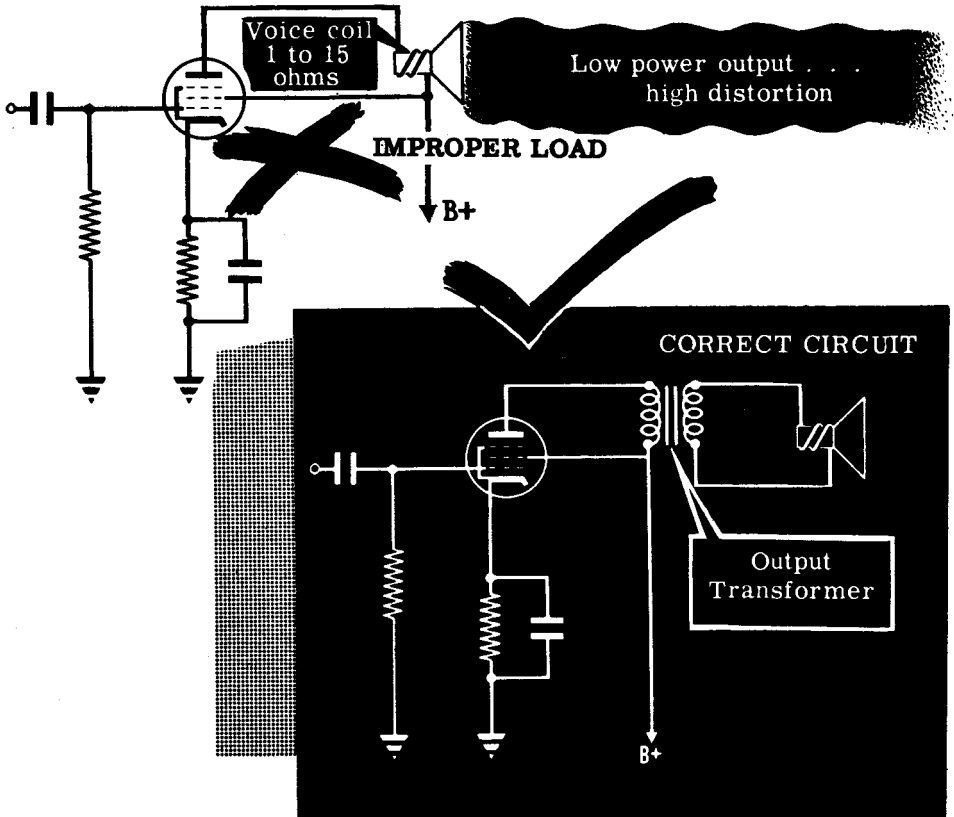

THE OUTPUT TRANSFORMER

Impedance Matching (continued)

Loudspeaker impedances and plate load impedances for different tubes vary widely. Since the primary impedance is set by the type of tube being used and the secondary load is set by the voice coil impedance, there must be some means of adjusting the relationship between primary and secondary impedance to obtain proper matching. The means of matching the two impedances is by varying the turns ratio of the transformer.

The output transformer that is shown below has a multi-tapped secondary so that you can select different numbers of secondary turns. Since the primary turns are fixed, if the secondary turns are varied then the turns ratio of the transformer is also varied. The primary impedance (Z_p) is related to the secondary load impedance (Z_s) by the following formula

$$Z_p = N^2 Z_s$$

where N is the turns ratio of the transformer $\frac{N_1}{N_2}$, N_1 is the primary turns

and N_2 is the number of secondary turns used. You can see that if the value of Z_s is fixed by the voice coil impedance, any value of Z_p can be obtained by varying the turns ratio.

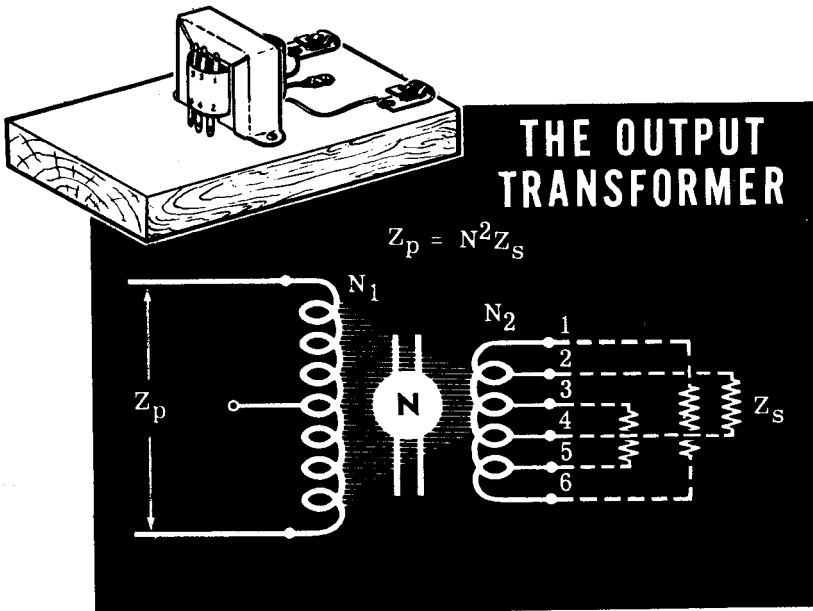

THE PUSH-PULL AMPLIFIER

How the Push-Pull Amplifier Works

In this topic, you will see that a very good type of power amplifier can be made by using a push-pull system. A power amplifier can be made using only one tube, but when you want to double the power, it is often more convenient to use two power tubes, rather than use one very large power tube. The obvious way to use two tubes would be to connect the two grids together and the two plates together (parallel connection) and thereby double the power output. However, there is a way that is better—that is to connect the tubes in push-pull. In a push-pull amplifier the input voltages to the grids of the two tubes are 180 degrees out of phase. This phase difference is often achieved by putting the signal into the primary of a transformer with a center-tapped secondary—the two grids are connected to the opposite ends of the secondary and the center tap is grounded or connected to a source of grid bias voltage.

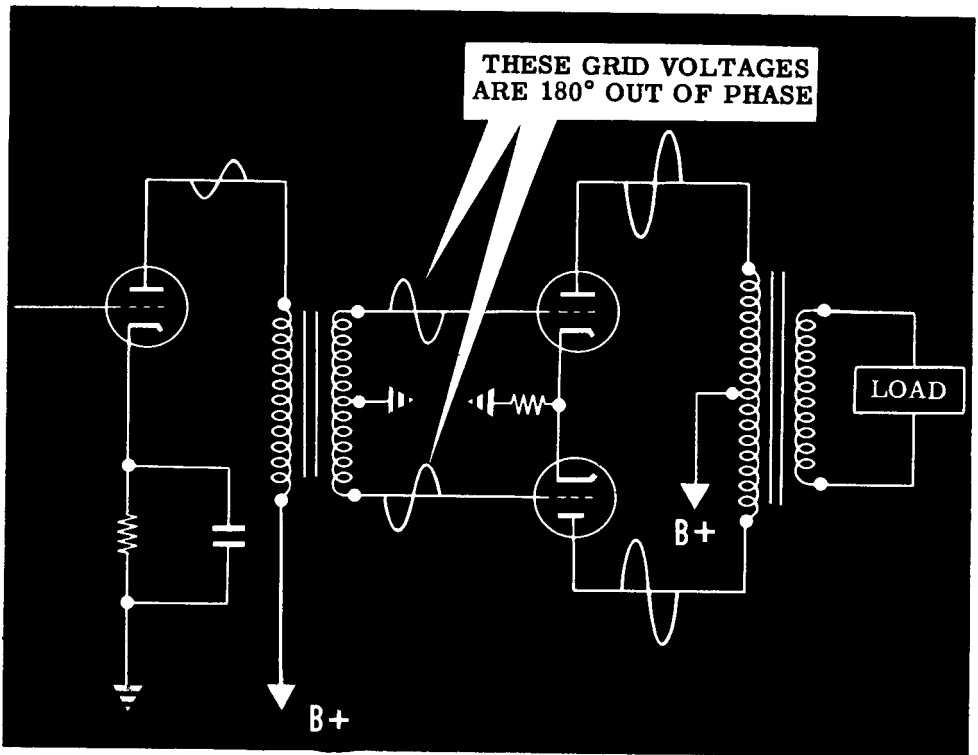

A TYPICAL PUSH-PULL CIRCUIT

The plates are connected to opposite ends of the primary winding of an output transformer and the center tap is connected to B+. The final output voltage appears across the output transformer secondary which is connected to the load.

THE PUSH-PULL AMPLIFIER

How the Push-Pull Amplifier Works (continued)

In a typical push-pull amplifier, the grids receive AC voltages from opposite terminals of a transformer secondary winding. The transformer secondary is center-tapped and the center tap is connected to ground. The AC grid voltages are 180 degrees out of phase. When one grid becomes less negative, the other grid becomes more negative by the same amount. The sum of the tube currents does not vary but remains pure DC since, when one current is increasing, the other is decreasing by the same amount. Because the sum of the two currents is pure DC, no bypass capacitor is needed across the cathode bias resistor.

In the output transformer, it is the difference between the two currents that is the output signal. The greater the signal input, the greater this difference and the greater the output.

Below you see a set of typical wave forms taken from a push-pull amplifier which is working normally.

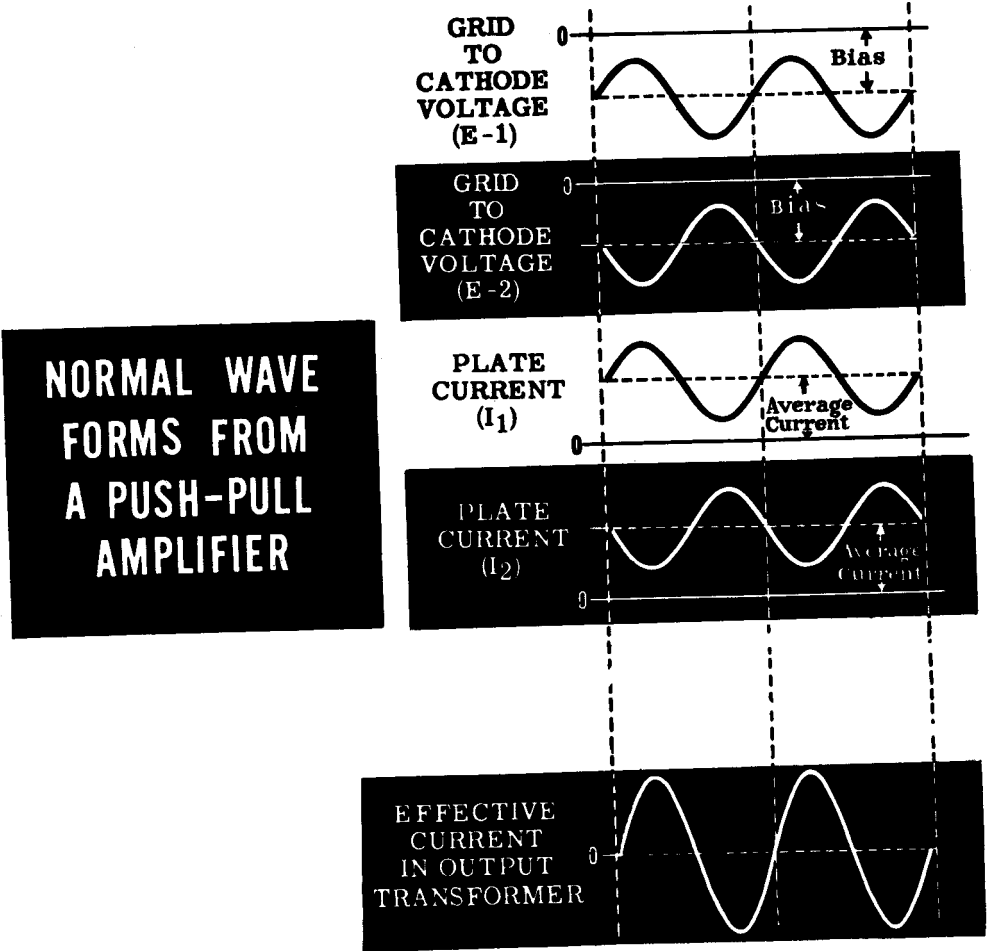

THE PUSH-PULL AMPLIFIER

How the Push-Pull Amplifier Works (continued)

Up to now, the only advantage of the push-pull circuit that has been mentioned has been the fact that no bypass capacitor is needed since the voltage variations produced across the cathode resistor by the out-of-phase plate current will cancel each other. If this were the only advantage of the push-pull circuit over the use of two tubes connected in parallel, the parallel combination would be more common than it is. Actually, there are some very important advantages which make the use of the push-pull circuit preferable.

Consider what happens if the two tubes in parallel are driven into cut-off by a large signal input. Both tubes go into cut-off together and distortion appears in the output. If the tubes are connected in a push-pull arrangement, one tube will be driven into cut-off on one half-cycle and the other tube on the next half-cycle. In the output, the distortion is minimized as you can see from the wave forms below.

DISTORTED WAVE FORMS DUE TO CUT-OFF

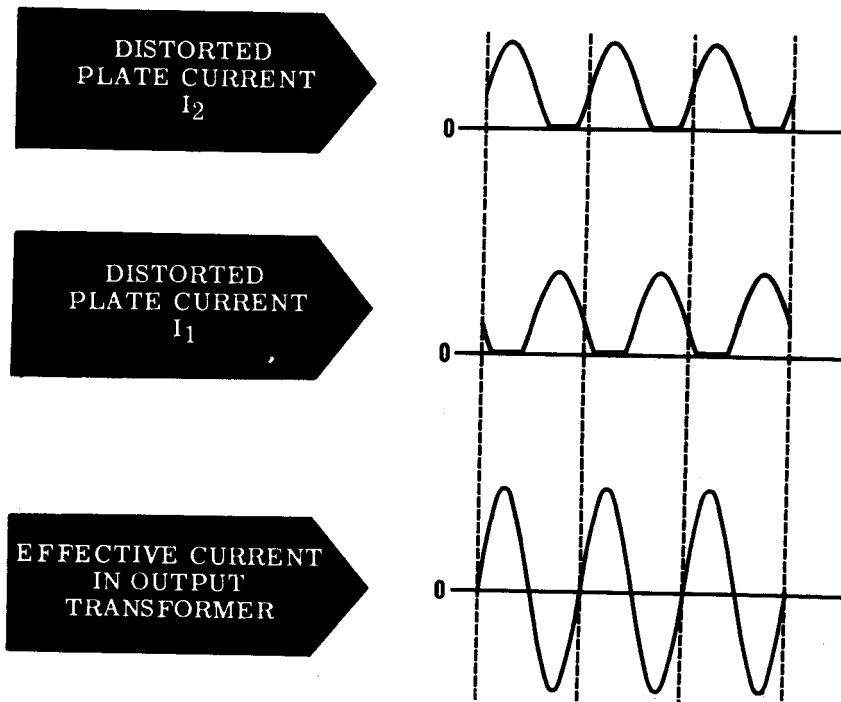

The reason that it is such a big advantage that the push-pull circuit reduces distortion is this—the tubes can be intentionally overdriven to produce a larger output and the output still will be practically undistorted.

THE PUSH-PULL AMPLIFIER

Phase Inverters

Transformers are objectionable in some push-pull circuits because of their size, weight and cost. It is sometimes desirable to obtain two signal voltages 180 degrees out of phase with each other without the use of a transformer. A circuit that accomplishes this is called a phase inverter.

You will recall that the two tubes of a push-pull system should be supplied with two signal voltages of equal amplitude but 180 degrees out of phase. In the circuit diagram shown below, the signal for the grid of the upper tube (V_2) of the push-pull system comes from the triode (V_1), while the other triode (V_3) is the phase inverter which drives the other push-pull tube (V_4).

The incoming signal is impressed on the control grid of V_1 through capacitor C_1 . The output from V_1 appears across the plate load resistor R_3 and is coupled through capacitor C_2 to the grid of the upper push-pull power amplifier V_2 . The full output of V_1 appears between grid and ground of V_2 —across R_4 and R_5 in series. Resistors R_4 and R_5 form a voltage divider that supplies the signal to the grid of the phase inverter tube V_3 . The values of R_4 and R_5 are so chosen that the amount of signal fed to V_3 is exactly the same as the input signal to V_1 .

The important thing to remember at this time is that there is always a 180 degree phase shift between the signal at the plate of an amplifier tube and the signal at the grid. Therefore, the signal taken from the grid of V_2 at the junction of R_4 and R_5 , will be shifted 180 degrees when it is amplified by V_3 . The output of V_3 is fed through capacitor C_4 to the grid of the lower push-pull power amplifier tube V_4 . Since the signals on the grids of the triodes V_1 and V_3 are equal in amplitude and 180 degrees out of phase, their outputs will also be equal in amplitude and 180 degrees out of phase. You see that these output signals are fed to the grids of the push-pull amplifier so that the requirements for push-pull operation have been met.

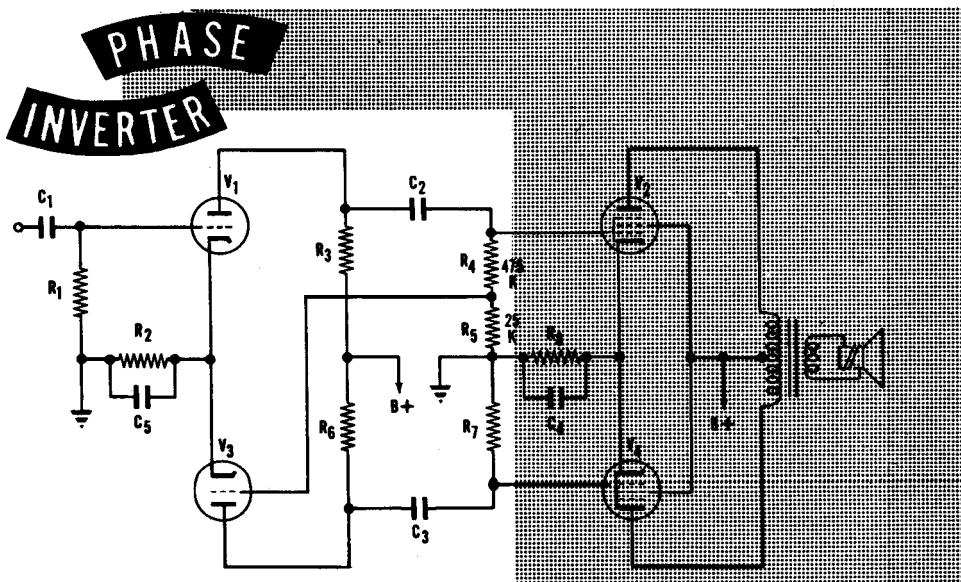

THE PUSH-PULL AMPLIFIER

How the Phase Inverter Works

Suppose we apply a signal to the phase inverter and trace it through the complete push-pull amplifier. If a 1 volt signal is applied to the grid of V_1 and we assume the gain of V_1 to be 20, there will be a 20 volt signal at the plate. This signal will appear between grid and ground of V_2 —across R_4 and R_5 in series. Since R_4 is 19 times as large as R_5 , 19 volts will appear across R_4 and there will be 1 volt across R_5 . The 1 volt signal across R_5 is applied to the grid of V_3 at the junction of R_4 and R_5 . Since the gain of V_3 is the same as that of V_1 (20), the output voltage of V_3 will be 20 volts in amplitude and shifted in phase 180 degrees. This output voltage is applied between grid and ground of V_4 .

You can see that we have provided the push-pull amplifier tubes with two signals equal in amplitude (20V) and 180 degrees out of phase so that proper push-pull operation will take place.

VOLTAGE WAVE FORMS IN A PHASE INVERTER

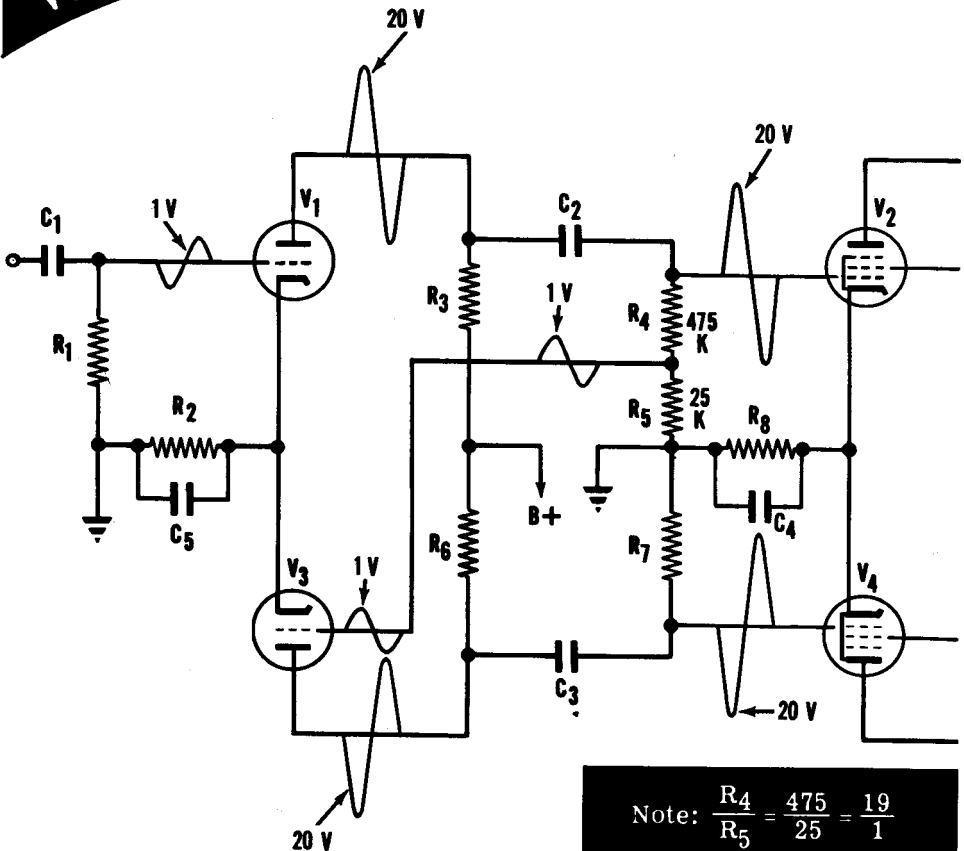

THE PUSH-PULL AMPLIFIER

Another Type of Phase Inverter

The phase inverter you will use has half of the load resistance in the cathode circuit (R-1), and half in the plate circuit (R-2). The same current flows in each of these resistors and since they have the same value, the same voltage appears across each of them. These voltages are 180 degrees out of phase. No signal appears across R-3 since it is bypassed with a large condenser.

The input voltage is applied between grid and ground and only part of this signal appears between grid and cathode. The tube current responds to the grid-to-cathode voltage and this current flows through R-1 and R-2, causing signal voltages to appear across these resistors.

The voltage across R-1 (and also the voltage across R-2) is always less than the input voltage. This is so since the grid-to-cathode voltage is equal to the difference between the input voltage and the voltage across R-1. Therefore, the gain of this type of phase inverter (or phase splitter) is less than one.

The two outputs are connected to the control grids of the following push-pull stage. These outputs are 180 degrees out of phase with each other since one is taken from the plate and the other from the cathode. Thus, when the plate current is increasing, the "top" of R-2 is becoming less positive and the "top" of R-1 is becoming more positive. The phase inverter has taken an AC signal input and produced two output signals of equal magnitudes and of opposite phase.

Compare this circuit to the transformer circuit shown below.

THE SINGLE-TUBE PHASE INVERTER CIRCUIT

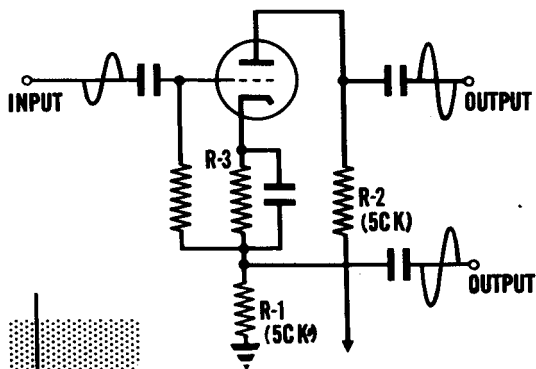

... ACTS LIKE THIS

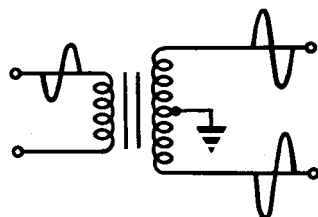

THE PUSH-PULL AMPLIFIER

Complete Diagram of Push-Pull Power Amplifier

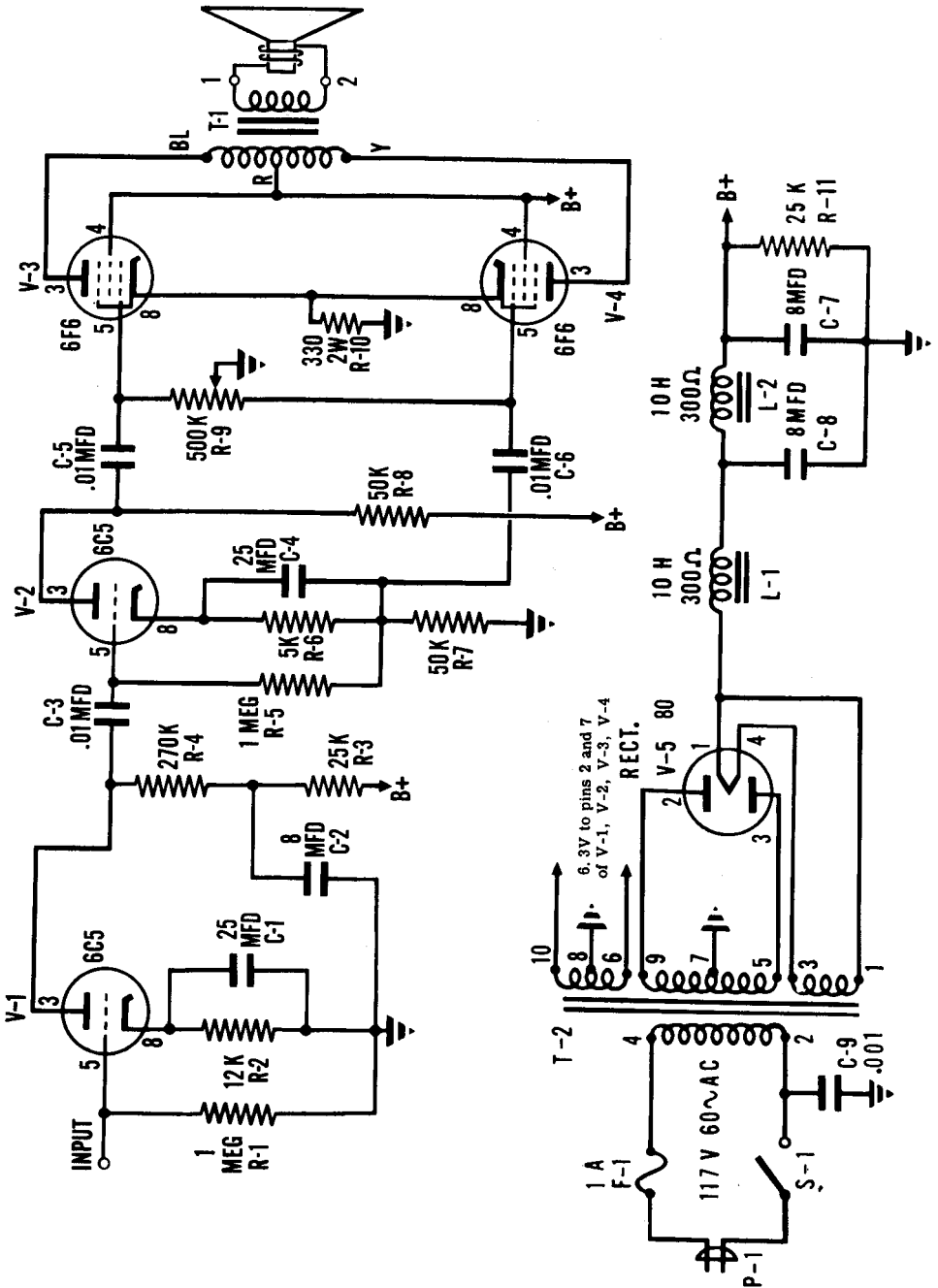

THE PUSH-PULL AMPLIFIER

The Advantages of a Push-Pull Amplifier

1. The core of the output transformer is not saturated by DC current flow in the transformer primary winding since the two halves of the primary winding are magnetized in opposite directions. This causes a cancellation of the magnetic lines of flux.
2. More than twice the amount of undistorted power output is produced by using a push-pull system than could be furnished by one tube.
3. Any hum voltages from the plate power supply will be canceled out.
4. No signal is fed from the plates of the power tubes to the rest of the amplifier through the B+ lead because the plate signals cancel out at B+. This also means that no bypass condenser is required across the common cathode resistor since the two signal voltages developed cancel each other out.

The output of a push-pull amplifier must be matched to the load with which it is going to be used, so that there will be a maximum transfer of power. Output transformers are rated for both the primary and secondary impedances, and the impedance of the primary will be its rated value only when the secondary is terminated with its own rated impedance. Only under a matched condition is there maximum power output.

Some output transformers have specific impedances to which both the primary and secondary must be matched. If the secondary has a load connected to it which is lower in impedance than the rated value, the reflected impedance on the primary would be lower than its rated value, resulting in loss of power output. If the secondary has a load connected to it which is higher in impedance than the rated value, the reflected impedance on the primary would be higher than its rated value, also resulting in loss of power output.

Other output transformers are of the "universal" type. This type has a secondary winding with a number of taps. By selecting the proper taps on the secondary, you may properly match a variety of load impedances to the transformer and consequently get a maximum transfer of power from the amplifier to the load.

THE PUSH-PULL AMPLIFIER

Review of the Push-Pull Amplifier

PUSH-PULL CIRCUIT uses two vacuum tubes and a transformer to double the power output of the circuit. The tube grid voltages are 180 degrees out of phase.

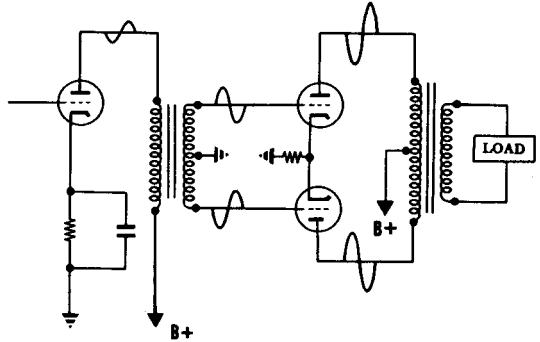

DISTORTED WAVE FORMS due to overdriving the tubes do not noticeably affect the current wave form in the output transformer of a push-pull amplifier.

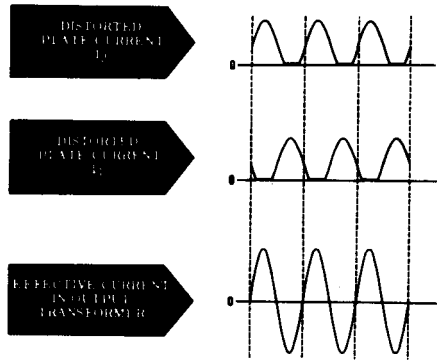

PHASE INVERTER produces two signal voltages 180 degrees out of phase without using a transformer. A phase inverter may use one or two vacuum tubes.

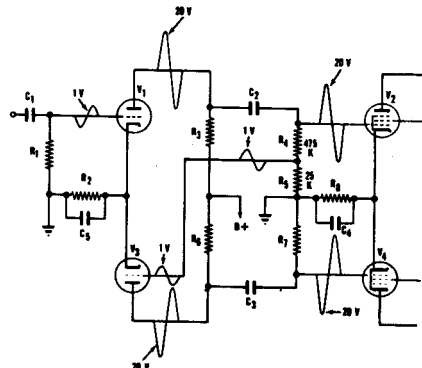

PUSH-PULL POWER AMPLIFIER consists of a voltage amplifier, a phase splitter (inverter), two power amplifier tubes and an output transformer.

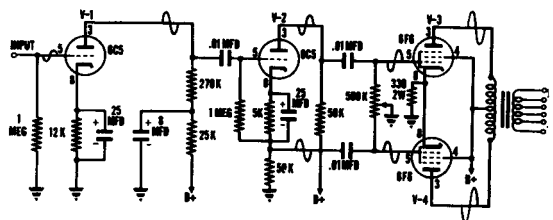

MICROPHONES, EARPHONES AND LOUDSPEAKERS

Principles of Sound

When it is desired to send an electric current from one point to another, wires are used to carry this current. When sound is sent directly from one point to another, it is the particles of air that carry the sound. In other words, in the transmission of electricity or sound, a medium must exist between the points of transmission; with electricity, wires are used, with sound, air is used.

Sound is actually the motion of pressure waves of air. Therefore, any device that produces sound, such as the human vocal cords, is a device for varying the pressure of the surrounding air. All musical instruments make use of this principle by having some part, such as a taut string, a reed or stretched membrane, which when set into vibration, produces varying pressure waves of air. In the piano, when a key is struck, a taut string is set into vibration. The string vibrates on both sides of its resting point and compresses and expands the surrounding air. When the string (see figure below) moves from its resting point to the right, the air to the right of the string is compressed (increased in pressure). When the string moves to the left of its resting point, the air to the right of the string will be expanded (reduced in pressure). If a sound detecting device, such as the human ear, is located in the vicinity of the vibrating string, the varying pressure waves will strike the eardrum and produce the sensation of sound.

The number of complete vibrations of the string occurring per second determines the frequency or pitch of the resulting sound wave. The intensity or amplitude of the sound wave is determined by the amount of displacement of the string from its resting point.

The sound produced by the human voice may vary in intensity in the ratio of 10,000 to 1 and cover a range of about 60 to 10,000 cycles. In music, the intensity variation may be as great as 100,000 to 1 and the frequency range is from about 40 to 15,000 cycles.

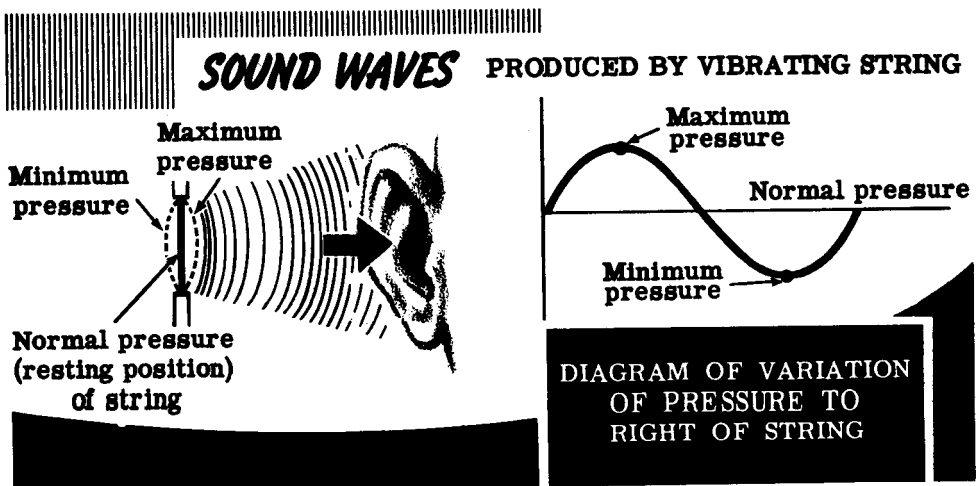

MICROPHONES, EARPHONES AND LOUDSPEAKERS

Characteristics of Microphones

The sound waves that you produce when you talk or sing can be converted into corresponding electrical impulses by the mechanism of a microphone. A diaphragm inside the microphone is actuated by the air pressure variations of the sound waves, and in turn causes the microphone to produce an AC voltage of the same frequency as the original sound. The amplitude of this AC voltage will be proportional to the intensity of the sound.

The ratio of electrical output (voltage) to the intensity of sound input is the sensitivity of a microphone. Sensitivity varies widely among different types of microphones. The electrical output of a microphone depends on the type of microphone and the distance between the microphone and the sound source. The output decreases as this distance is increased.

The frequency response of a microphone is a measure of its ability to convert different sound frequencies into alternating current. With a fixed sound intensity at the microphone, the electrical output may vary widely as the frequency of the sound source is varied. For clear understanding of speech, however, only a limited frequency range is necessary; from 200 to 4,000 cycles.

If the output of a microphone shows only small variations in amplitude between its upper and lower frequency limits, it is said to have a flat frequency response.

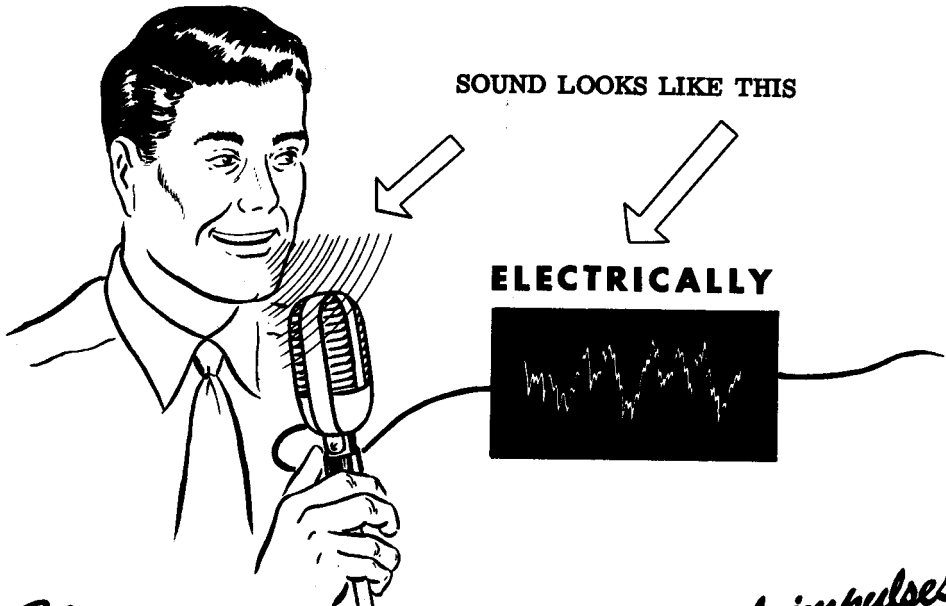

Changing sound waves into electrical impulses

You will study various types of microphones on the next few sheets.

MICROPHONES, EARPHONES AND LOUDSPEAKERS

The Carbon Microphone

The most common type of microphone, the carbon microphone, is restricted to a large extent to communications systems for the transmission of speech. This microphone is the most rugged of all the different types and supplies the largest output from a given sound input.

The figure below shows the principal parts of a single-button carbon microphone. This microphone operates by using the varying pressure waves of sound to vary the resistance between carbon granules. These carbon granules are sealed in a brass or carbon cup with an electrode that is mechanically connected to a thin diaphragm. The electrode acts as a plunger in compressing the carbon granules in the cup, which is often called a "carbon button." The carbon button is connected in series with a source of DC voltage and the primary of a microphone transformer.

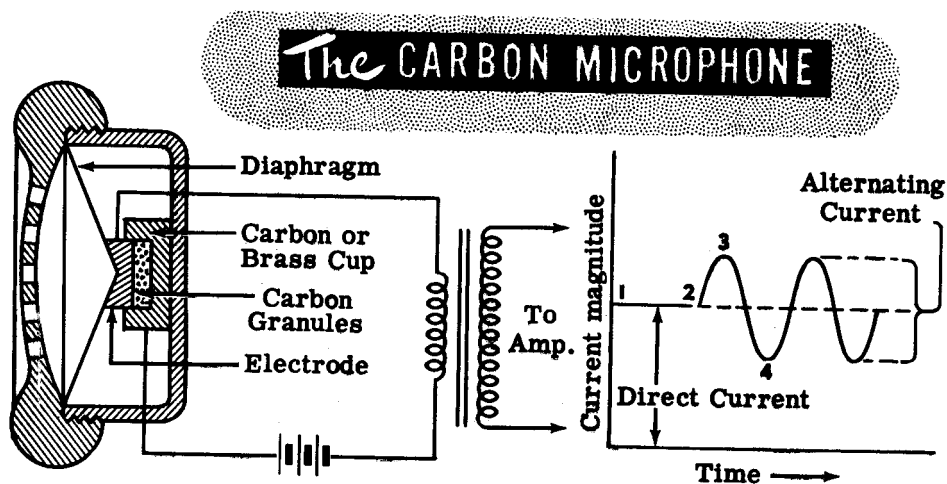

When no sound waves strike the diaphragm, the carbon granules are at rest. In this condition, the resistance of the carbon button, between the cup and the electrode, is constant and so is the circuit current. This is illustrated in the region from 1 to 2 in the illustration. When the pressure waves of sound strike the diaphragm, the diaphragm and the attached electrode move in and out, varying the pressure on the carbon granules. An increase in air pressure moves the diaphragm in, compressing the carbon granules and lowering their resistance. This causes the current to increase, which is shown in the region from 2 to 3 of the graph. A decrease in air pressure causes the diaphragm to move out which reduces the pressure on the granules raising their resistance and decreasing the circuit current. This is shown in the region from 3 to 4 of the graph.

In this manner, sound waves vary the circuit current in accordance with the sound pressure variations. These current variations through the primary of the transformer induce a stepped-up voltage in the secondary which is fed to the grid of an amplifier. The output of the amplifier can be connected to a loudspeaker or used to control the output of a radio transmitter.

The Crystal Microphone

One of the disadvantages of the carbon microphone is that it requires an external source of DC voltage for operation. In certain applications, a DC source for the microphone is not easy to obtain. In addition, the carbon granules may pack together due to the DC current arcing between them. This will eventually reduce the sensitivity of the microphone. Because the granules move around and cause tiny arcs when the microphone is handled, objectionable noise may appear in the output.

The crystal microphone eliminates all the difficulties encountered with the carbon microphone because it operates on a different principle and requires no external source of voltage.

Certain crystalline substances such as quartz and Rochelle salts, generate a voltage when pressure is applied. Remember, "How Pressure Produces Electricity" in Basic Electricity? This is known as the piezo-electric effect and this principle is used in crystal microphones.

The construction of a crystal microphone is shown below. The flat crystal of Rochelle salts (used instead of quartz because it is more sensitive) is mounted between two metal plates which have external connections. A thin diaphragm is mechanically connected to the crystal through a hole in the front plate. When the sound waves strike the diaphragm, varying pressure is applied to the crystal through the connecting pin and a varying voltage is produced between the plates. Since the sound waves apply the pressure to the crystal, the output voltage wave form will be an exact duplicate of the original sound.

The crystal microphone is a high impedance microphone and is connected directly to the grid of the amplifier without using a transformer.

The **CRYSTAL** *microphone*

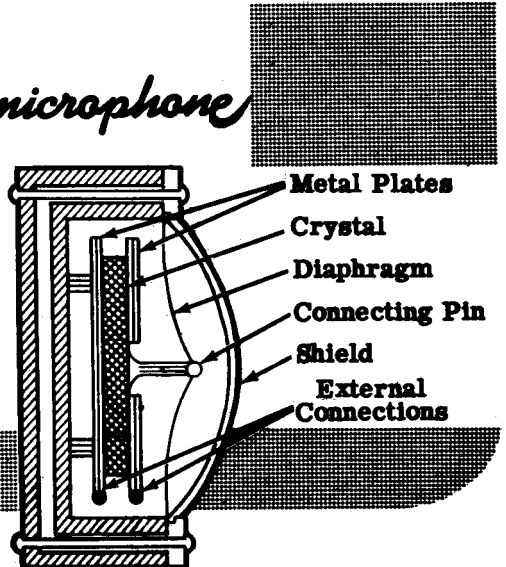
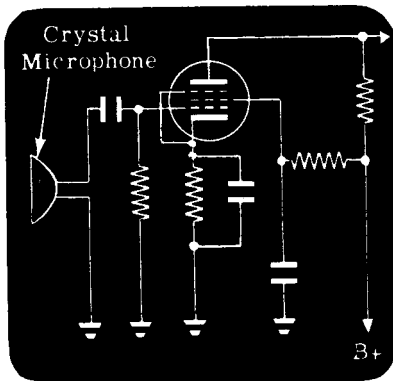

MICROPHONES, EARPHONES AND LOUDSPEAKERS

The Dynamic Microphone

In the dynamic or moving coil type of microphone, a coil of wire, which is rigidly attached to a diaphragm, is suspended in an air gap in which there is a very strong magnetic field. The magnetic field is produced by a permanent magnet. When the sound waves strike the diaphragm it moves back and forth with the coil. Since the coil is in the magnetic field, an AC voltage will be induced in it. This voltage will have the same wave form as the sound waves that strike the diaphragm.

The frequency of this AC voltage is the same as the frequency of the sound wave and the amplitude of the voltage is proportional to the sound wave's air pressure or intensity.

The dynamic microphone output feeds into a transformer which steps up the voltage and delivers a high impedance output so that it will work directly into the grid of an amplifier tube.

The dynamic microphone can be handled and moved during operation without producing undesirable noise in its output. It is dependable, requires no DC supply and has excellent frequency response between 20 and 9,000 cycles.

The DYNAMIC MICROPHONE

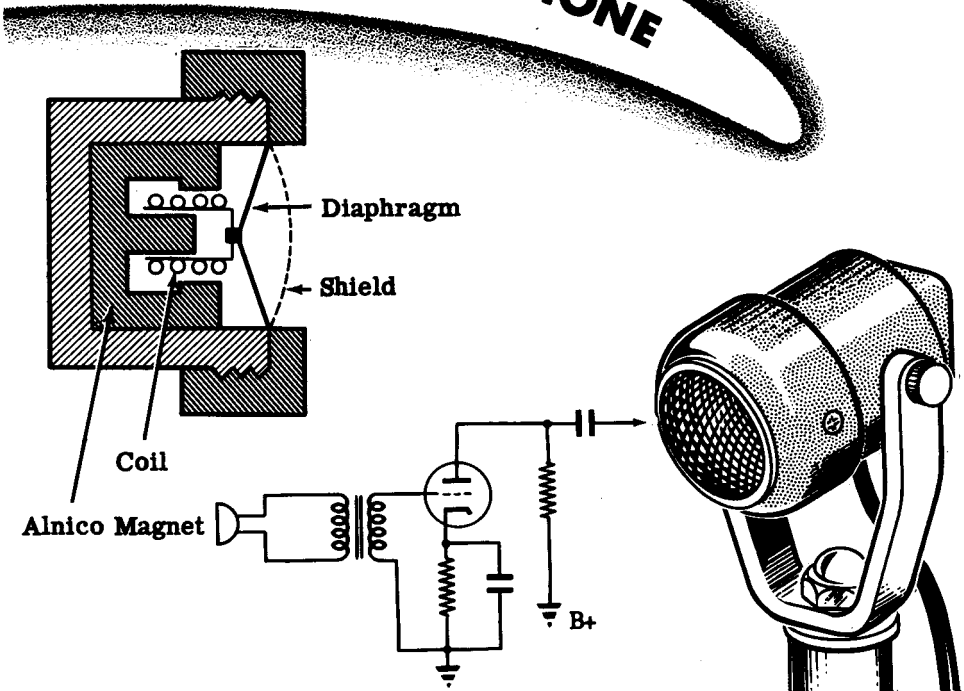

The Ribbon or Velocity Microphone

The ribbon microphone consists of a corrugated ribbon of aluminum alloy, which is suspended in a strong magnetic field so that the ribbon can be moved by the sound waves. As the sound waves move the ribbon back and forth, it cuts the lines of force between the poles of the magnets and a voltage is induced in the ribbon. This voltage is very small but it can be stepped up by a transformer, which is usually enclosed in the microphone casing. In addition to stepping up the voltage, the transformer raises the output impedance of the microphone so that it can be connected through a shielded cable to the grid of an amplifier.

The microphones described previously were pressure operated and had diaphragms which moved because the sound waves raised the air pressure on the front side of the diaphragm above the air pressure on the enclosed back side of the diaphragm. The ribbon microphone has no diaphragm and both front and back sides of the ribbon are exposed to the sound waves. The ribbon moves because of the small spaces between the ribbon and the pole pieces. The air passing through these spaces produces a difference in phase and pressure on the two sides of the ribbon. The voltage induced in the ribbon is determined not by the pressure of the air but by the velocity of the air particles traveling between the ribbon and pole pieces.

The Ribbon Microphone

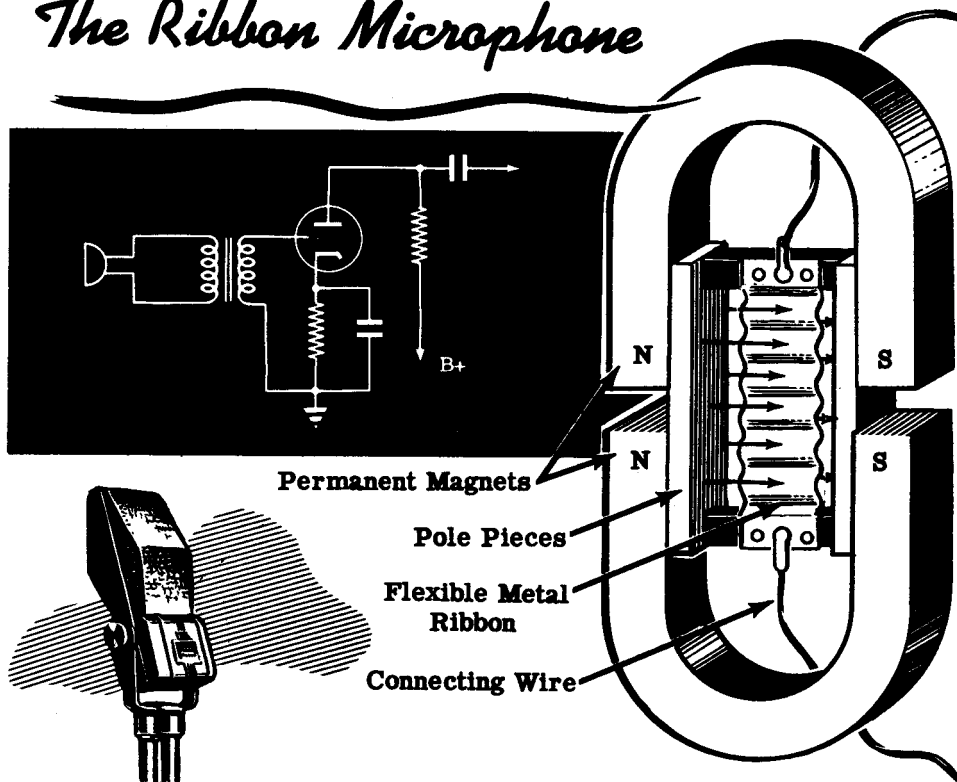

MICROPHONES, EARPHONES AND LOUDSPEAKERS

The Earphone

The purpose of a microphone is to convert sound pressure waves into corresponding AC voltages. The purpose of any sound reproducing device, such as an earphone or loudspeaker, is to change these AC voltages back into sound waves. To do this, the sound reproducer must be designed to vary the surrounding air pressure in accordance with the applied AC signal.

Earphones are used most often in communication systems where information is to be received but where high quality sound is not necessary. In some earphones, crystal elements are used. These earphones make use of the piezo-electric effect and act like a microphone in reverse. The amplified AC signal voltages are applied to the metal plates of a Rochelle salt crystal element, and these voltage variations cause the crystal to change its shape and produce pressure variations in the surrounding air, resulting in sound reproduction. The crystal earphones are light in weight and have excellent frequency response.

Most earphones operate on magnetic principles; a typical magnetic earphone is shown in the illustration below. A coil of fine wire is wound on each pole of a "U" shaped permanent magnet. These coils are usually connected in series and have external leads connected to the series combination. A soft iron diaphragm is held rigidly in place about one sixteenth of an inch away from the pole ends.

With no signal applied to the coils, the permanent magnet exerts a constant pull on the diaphragm. When the audio frequency (AC) currents flow through the coils, they become electromagnets. The magnetic fields that are produced by these coils are continuously reversing direction in accordance with the audio signal. At some instant the electromagnetic field will add to the permanent magnet's field and the diaphragm will be pulled in further, reducing the air pressure on the outer side. An instant later, the electromagnetic field will cancel some of the permanent magnet field and the diaphragm will move out beyond its normal position and compress the air in front of it. In this way the audio signal has been converted back into sound air pressure variations which, when striking the eardrum, produce sound.

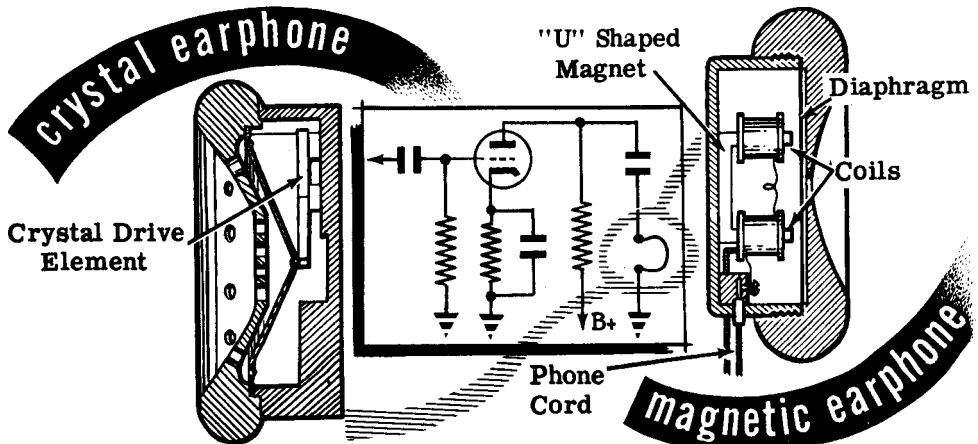

MICROPHONES, EARPHONES AND LOUDSPEAKERS

The Dynamic Loudspeaker

The dynamic loudspeaker is very similar in construction to the dynamic microphone. In fact, the permanent magnet type of speaker is sometimes used in intercommunication systems as both speaker and microphone.

Cross-sections of the permanent magnet dynamic speaker and the electro-magnet dynamic speaker are shown below. The construction of both types is exactly the same except for the method of obtaining the magnetic field. The electromagnetic type uses a field coil wound on a soft iron coil. A DC current is passed through the field coil and a strong magnetic field is produced in the air gap. In the permanent magnet type, a strong permanent magnet made of alnico alloy takes the place of the field coil. A coil of wire, which has relatively few turns, is suspended in the air gap and is attached to a paper cone. The outer edge of the cone and the voice coil suspension are corrugated and attached to the speaker frame. The corrugations allow the cone to move in and out freely.

The amplifier is connected to the voice coil through an output transformer which serves as an impedance-matching device. The AC audio signal current flowing through the voice coil causes it to generate a magnetic field whose polarity is continuously varying. When the voice coil field has a polarity that aids the field in the air gap, the voice coil and cone move in, reducing the air pressure in front of the cone. When the voice coil field is in opposition to the field in the air gap, the voice coil and cone are pushed out, compressing the air in front of the cone. In this way, audio signal currents are changed into sound pressure waves.

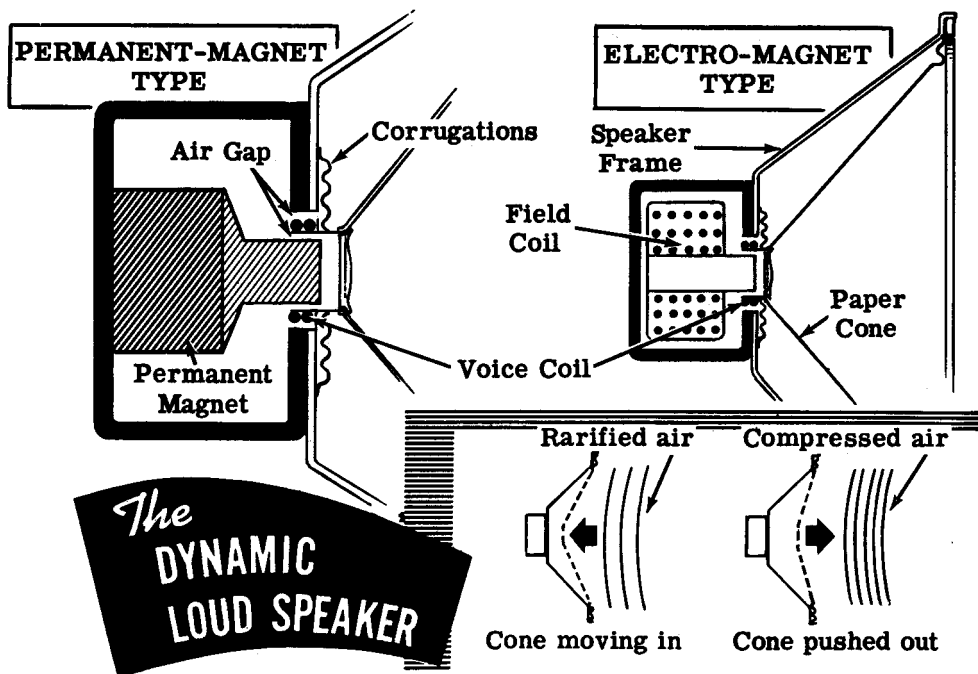

MICROPHONES, EARPHONES AND LOUDSPEAKERS

Review of Microphones, Earphones and Loudspeakers

SOUND WAVES are variations in air pressure produced by a vibrating solid body. The speed of vibration determines the pitch of the sound; the amplitude of vibration determines the loudness of the sound.

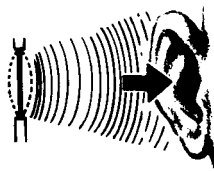

MICROPHONES change sound waves into electrical impulses. "Mikes" may be carbon, crystal, dynamic or ribbon type. The electrical impulses are fed into the grid of an amplifier either directly or through a step-up transformer.

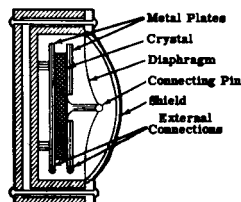
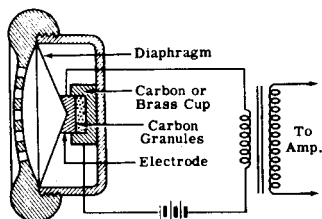

EARPHONES operate like microphones in reverse, and produce sound waves in response to electrical impulses. Both the crystal and magnetic earphones are widely used, the magnetic type being most common.

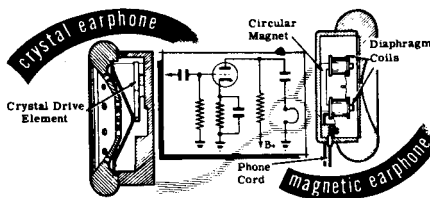

LOUDSPEAKERS are used where high quality sound reproduction is required. The dynamic loudspeaker operates like a dynamic microphone in reverse and may be of the permanent or electro-magnet type.

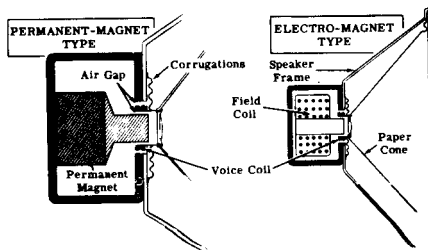

AUDIO AMPLIFIERS

Review of Audio Amplifiers

AMPLIFICATION — The process of changing a low AC input to a high AC output. A device which performs amplification is called an amplifier.

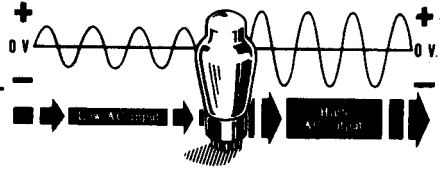

THE TRIODE — A vacuum tube similar to a diode but containing a grid which controls plate current between cathode and plate.

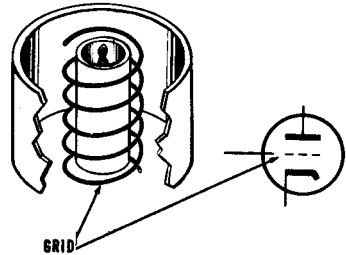

TRIODE CHARACTERISTICS — A plot of the variations in plate current as grid voltage changes; a measure of a triode's ability to amplify.

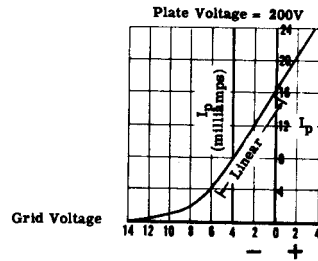

GRID BIAS — The amount of grid voltage determines the class of amplifier operation. In Class A the bias is less than cut off; in Class B bias is at or near cut-off; in Class C bias is much less than cut-off.

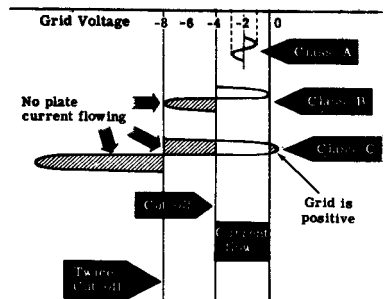

TRIODE AMPLIFIER — A simple circuit using a single triode with biasing components. This circuit is not used alone in actual equipment.

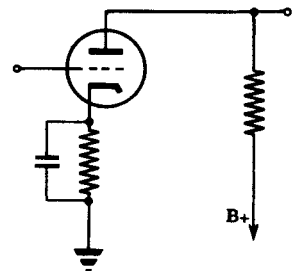

AUDIO AMPLIFIERS

Review of Audio Amplifiers (continued)

THE PENTODE — A tube which uses a suppressor grid and a screen grid between control grid and plate. It has greater amplification than the triode.

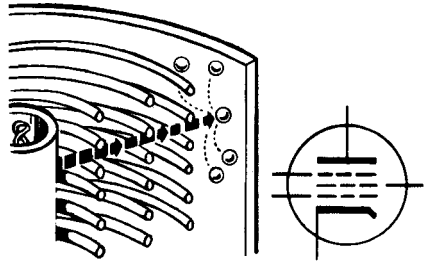

SINGLE-STAGE AMPLIFIER — A circuit consisting of a vacuum tube amplifier, biasing components, a load resistor, a decoupling network and a resistor and capacitor to provide coupling to another stage.

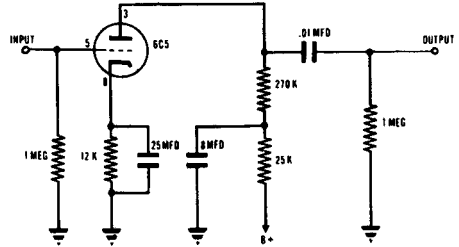

TWO-STAGE RC-COUPLED AMPLIFIER — A circuit consisting of two amplifier stages. The input to the grid of the second amplifier tube is the output from the first stage of amplification.

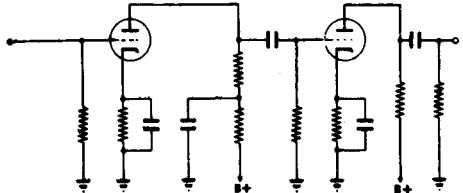

TRANSFORMER-COUPLED AMPLIFIER — A two-stage amplifier identical to the two-stage RC-coupled amplifier except that a transformer is used to couple the first and second stages.

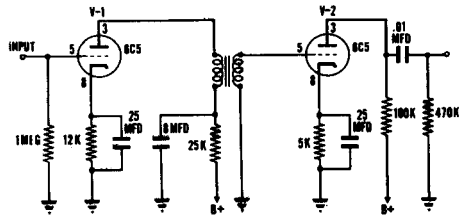

VOLTAGE GAIN — The total amplification of a two-stage (or multistage) amplifier is the product of the amplifications of each stage. The ratio of the output voltage of the final stage to the input voltage to the first stage is called the gain of the amplifier.

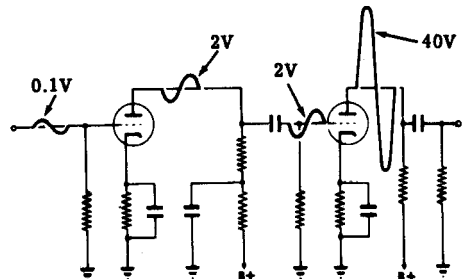

AUDIO AMPLIFIERS

Review of Audio Amplifiers (continued)

AUDIO POWER AMPLIFIER — An amplifier designed to supply power to a load. Its input is the output of a voltage amplifier stage. Its output feeds a load through an output transformer.

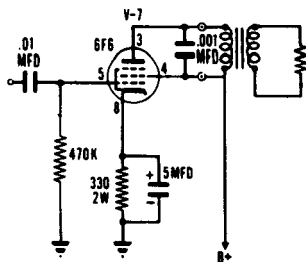

PHASE INVERTER — A circuit which uses one or two vacuum tubes to produce two signal voltages 180 degrees out of phase. It is also called a phase splitter and replaces the transformer in a push-pull circuit.

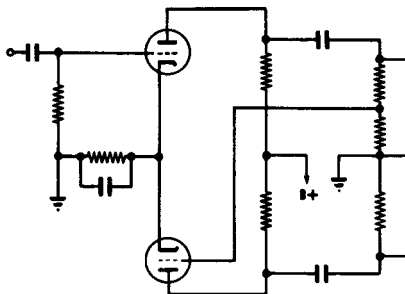

PUSH-PULL POWER AMPLIFIER — A circuit consisting of a voltage amplifier, a phase splitter (inverter), two power amplifier tubes and an output transformer.

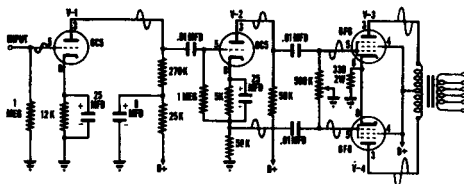

THE OUTPUT TRANSFORMER — A transformer used to couple the power amplifier output to the load. It matches the low load impedance to the high impedance required by the amplifier.

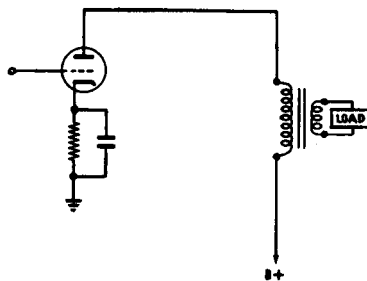

MICROPHONES, EARPHONES AND LOUDSPEAKERS — Carbon, crystal, dynamic and ribbon microphones are used to change sound waves into electrical impulses. Earphones and loudspeakers change electrical impulses to sound waves.

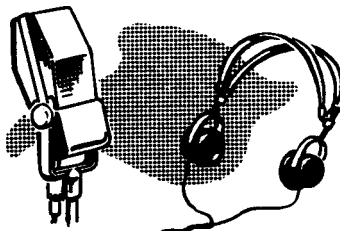

INDEX

INDEX TO VOL. 2

(Note: A cumulative index covering all five volumes in this series will be found at the end of Volume 5.)

- Amplification, examples of, 2-1 to 2-3
- Amplifiers, 2-1 to 2-10
 - advantages of push-pull type, 2-85
 - characteristics of audio power type, 2-71 to 2-73
 - characteristics of transformer-coupled type, 2-69, 2-70
 - characteristics of the two-stage type, 2-60, 2-61
 - classes of, 2-30, 2-31
 - diagram of push-pull type, 2-84
 - how they work, 2-17 to 2-19
 - how the push-pull type works, 2-78 to 2-80
 - single-stage, 2-55 to 2-57
 - push-pull type, 2-78 to 2-86
 - transformer coupled, 2-67 to 2-70
 - triode type, 2-24 to 2-41
 - two-stage RC coupled type, 2-58 to 2-66
 - typical stage, 2-55
- Beam power tube, 2-50, 2-51
 - construction of a typical tube, 2-51
- Bias, B+ power supply, 2-34
 - battery, 2-32
 - cathode, 2-35
 - grid voltage, 2-24 to 2-26
 - power supply, 2-33
- Cathode bypass capacitor, 2-38 to 2-40
- Cathode resistor, 2-36, 2-37
- Coupling, amplifier stages, 2-59
 - transformer, 2-67, 2-68
- Decoupling filters, 2-56, 2-57
- Earphones, 2-93
- Frequency response, 2-62 to 2-64
 - curve, 2-65
- Gain, increase of, 2-58
- Impedance matching, 2-76, 2-77
- Loudspeakers, dynamic type, 2-94
- Microphones, 2-88 to 2-92
 - carbon, 2-89
 - characteristics of, 2-88
 - crystal, 2-90
 - dynamic type, 2-91
 - ribbon or velocity type, 2-92
- Output transformers, 2-74 to 2-77
 - job of, 2-74, 2-75
- Pentodes, 2-47 to 2-49, 2-52, 2-53
 - construction of a typical tube, 2-49
 - how they work, 2-48
 - summary of operation of, 2-52, 2-53
- Phase inverters, 2-81 to 2-83
 - another type of, 2-83
 - how they work, 2-82
- Review, Audio Amplifiers, 2-96 to 2-98
 - Microphones, Earphones and Loudspeakers, 2-95
 - The Push-Pull Amplifier, 2-86
 - The Tetrode and the Pentode, 2-54
 - The Triode, 2-23
 - The Triode Amplifier, 2-41
 - The Two-Stage RC Coupled Amplifier, 2-66
- Sound, principles of, 2-87
- Tetrodes, 2-42 to 2-46
 - eliminating effects of secondary emission, 2-47
 - normal operation of, 2-46
 - screen grid, 2-43
 - secondary emission in, 2-44
 - static characteristics of, 2-45
 - why they were developed, 2-42
- Triodes, 2-11 to 2-23
 - construction of typical tube, 2-12
 - control grid in, 2-14, 2-15
 - how they work, 2-13
 - similarity to the diode, 2-16
- Triode amplifiers, why proper bias is necessary, 2-27 to 2-29
- Triode tube characteristics, amplification factor, 2-20
 - plate resistance, 2-21
 - transconductance, 2-22
- Vacuum tubes, amplification, 2-11
 - how they were developed, 2-8, 2-9
 - types of, 2-6, 2-7
 - what they can do, 2-4, 2-5

HOW THIS OUTSTANDING COURSE WAS DEVELOPED:

In the Spring of 1951, the Chief of Naval Personnel, seeking a streamlined, more efficient method of presenting Basic Electricity and Basic Electronics to the thousands of students in Navy speciality schools, called on the graphiological engineering firm of Van Valkenburgh, Nooger & Neville, Inc., to prepare such a course. This organization, specialists in the production of complete "packaged training programs," had broad experience serving industrial organizations requiring mass-training techniques.

These were the aims of the proposed project, which came to be known as the Common-Core program: to make Basic Electricity and Basic Electronics completely understandable to every Navy student, regardless of previous education; to enable the Navy to turn out trained technicians at a faster rate (cutting the *cost* of training as well as the time required) without sacrificing subject matter.

The firm met with electronics experts, educators, officers-in-charge of various Navy schools and, with the Chief of Naval Personnel, created a dynamic new training course . . . completely up-to-date . . . with heavy emphasis on the visual approach.

First established in selected Navy schools in April, 1953, the training course comprising Basic Electricity and Basic Electronics was such a tremendous success that it is now the *backbone* of the Navy's *current* electricity and electronics training program!*

The course presents one fundamental topic at a time, taken up in the order of need, rendered absolutely understandable, and hammered home by the use of clear, cartoon-type illustrations. These illustrations are the most effective ever presented. *Every page has at least one such illustration—every page covers one complete idea!* An imaginary instructor stands figuratively at the reader's elbow, doing demonstrations that make it easier to understand each subject presented in the course.

Now, for the first time, Basic Electricity and Basic Electronics have been released by the Navy for civilian use. While the course was *originally* designed for the Navy, the concepts are so broad, the presentation so clear—*without* reference to specific Navy equipment—that it is ideal for use by schools, industrial training programs, or home study. *There is no finer training material!*

"Basic Electronics" consists of *five* volumes, as follows: *Vol. 1—Introduction to Electronics, Diode Vacuum Tubes, Dry Metal Rectifiers, What a Power Supply Is, Filters, Voltage Regulators. Vol. 2—Introduction to Amplifiers, The Triode Tube, Tetrodes & Pentodes, Audio Voltage & Power Amplifiers. Vol. 3—Video Amplifiers, RF Amplifiers, Oscillators. Vol. 4—Transmitters, Transmission Lines & Antennas, CW Transmission & Amplitude Modulation. Vol. 5—Receiver Antennas, Detectors & Mixers, TRF Receivers, Superheterodyne Receivers.*

*"Basic Electricity," the first portion of this course, is available as a separate series of volumes.

JOHN F. RIDER PUBLISHER, INC., 116 WEST 14th ST., N. Y. 11, N. Y.