

No. 170-5

basic electronics

by **VAN VALKENBURGH,
NOOGER & NEVILLE, INC.**

VOL. 5

RECEIVER ANTENNAS
DETECTORS & MIXERS
TRF RECEIVERS
SUPERHETERODYNE RECEIVERS

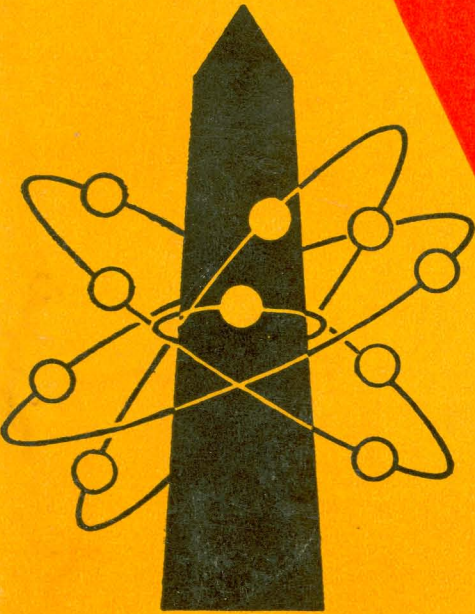

A. STICH

a **RIDER** publication

\$2.25

basic electronics

**by VAN VALKENBURGH,
NOOGER & NEVILLE, INC.**

VOL.5



JOHN F. RIDER PUBLISHER, INC.
116 West 14th Street • New York 11, N. Y.

First Edition

Copyright 1955 by

VAN VALKENBURGH, NOOGER AND NEVILLE, INC.

All Rights Reserved under International and Pan American Conventions. This book or parts thereof may not be reproduced in any form or in any language without permission of the copyright owner.

Library of Congress Catalog Card No. 55-6984

Printed in the United States of America

PREFACE

The texts of the entire Basic Electricity and Basic Electronics courses, as currently taught at Navy specialty schools, have now been released by the Navy for civilian use. This educational program has been an unqualified success. Since April, 1953, when it was first installed, over 25,000 Navy trainees have benefited by this instruction and the results have been outstanding.

The unique simplification of an ordinarily complex subject, the exceptional clarity of illustrations and text, and the plan of presenting one basic concept at a time, without involving complicated mathematics, all combine in making this course a better and quicker way to teach and learn basic electricity and electronics.

In releasing this material to the general public, the Navy hopes to provide the means for creating a nation-wide pool of pre-trained technicians, upon whom the Armed Forces could call in time of national emergency, without the need for precious weeks and months of schooling.

Perhaps of greater importance is the Navy's hope that through the release of this course, a direct contribution will be made toward increasing the technical knowledge of men and women throughout the country, as a step in making and keeping America strong.

Van Valkenburgh, Nooger and Neville, Inc.

New York, N. Y.

February, 1955

TABLE OF CONTENTS

VOL. 5 — BASIC ELECTRONICS

Introduction to Receivers	5-1
Receiver Antennas	5-16
TRF Receivers — RF Amplifier Stage	5-24
TRF Receivers — Audio Amplifier Stage	5-33
TRF Receivers — Regenerative Detector	5-38
TRF Receivers — Plate Detector	5-54
The Superheterodyne Receiver	5-57
Troubleshooting the Superheterodyne Receiver	5-89

INTRODUCTION TO RECEIVERS

History of Communication

Did it ever occur to you to ask, "Why is there such a thing as a radio receiver?" To answer this question, you have to know something about the history of man's attempt to improve his methods of communication.

Since the earliest days, man has always tried to increase the distance over which he could send messages.



INTRODUCTION TO RECEIVERS

History of Communication (continued)

Since the dawn of history, good communications have played an important part in the art of warfare. The victory message of the Battle of Marathon carried by a Greek runner was one of the earliest recorded instances of battle communications. Our own history offers another famous example in Paul Revere's ride.

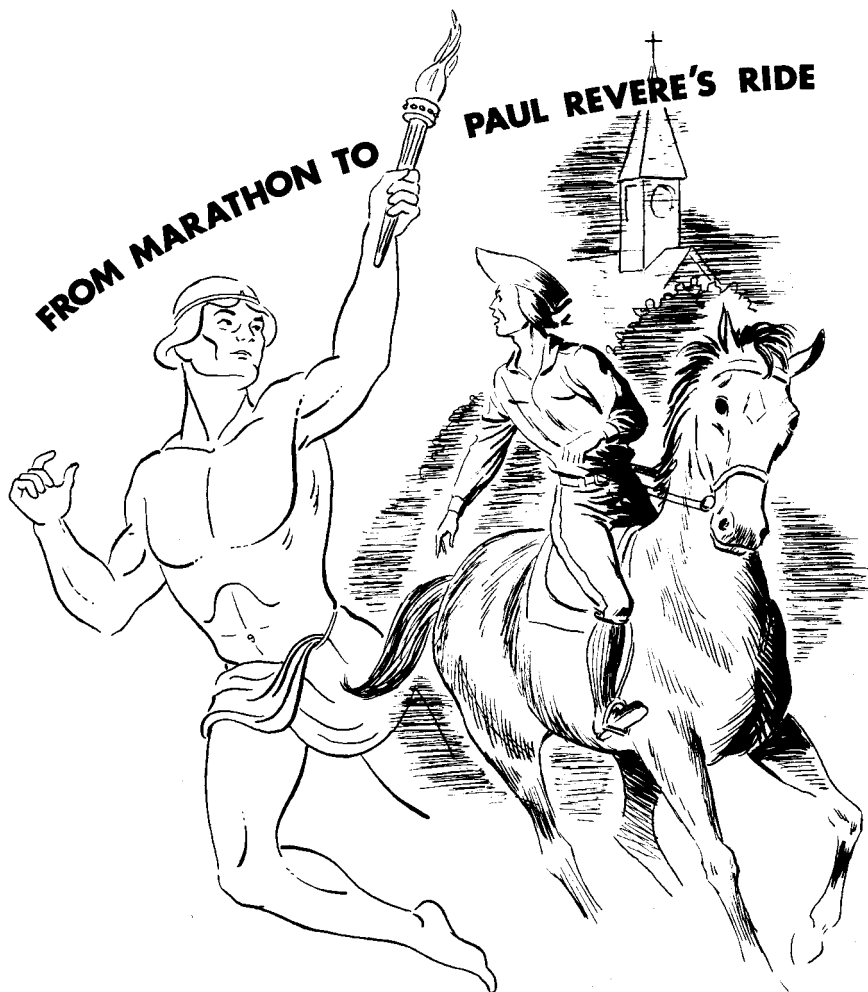

GOOD COMMUNICATIONS HAVE WON BATTLES

A result of poor communications was effectively demonstrated in the Battle of New Orleans during the War of 1812. Because news of the cessation of hostilities did not reach those in command until it was too late, this battle was fought several days after the war had ended.

INTRODUCTION TO RECEIVERS

History of Communication (continued)

Some of the more primitive methods of communication—human messengers and homing pigeons—have limited application. Today we still use semaphore signals and interrupted flashes of light to convey messages. Colored lights, rockets and flares perform functions similar to those of the warning hilltop fires of old, while whistles and sirens are still being used.

SOME **MODERN** VERSIONS OF
PRIMITIVE METHODS ARE

STILL IN USE.....

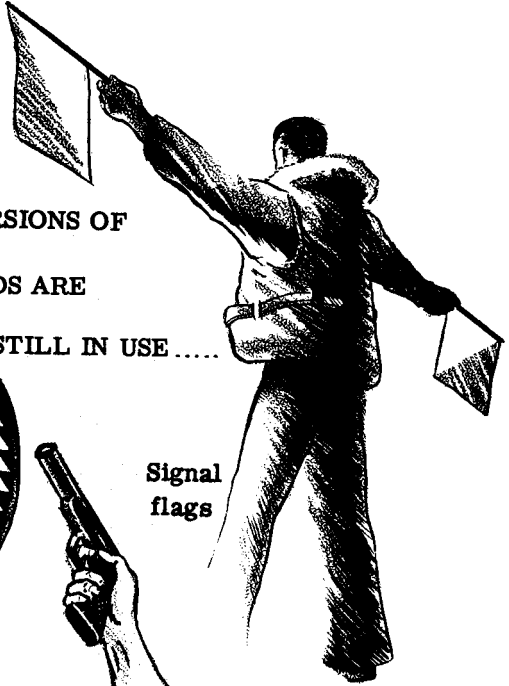

Signal
flags

Flares or Rockets

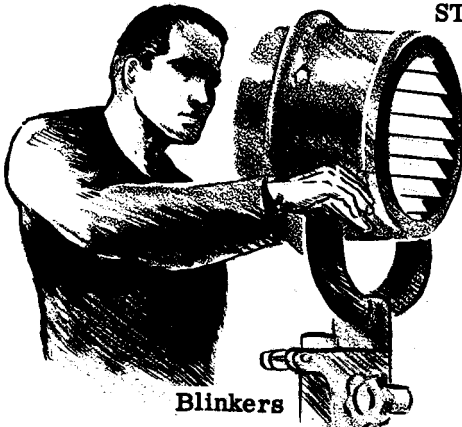

Blinkers



Sirens

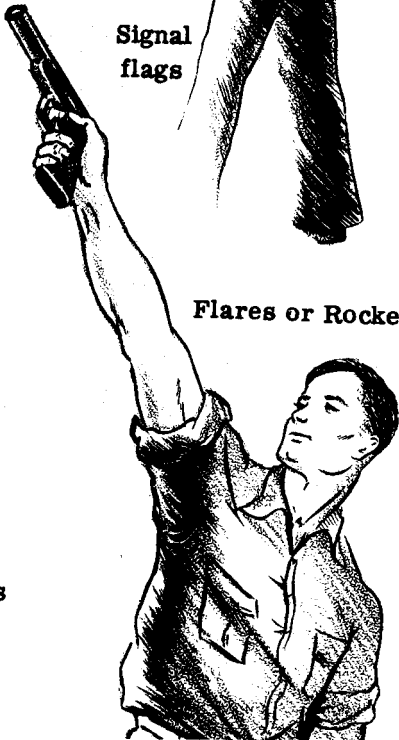

INTRODUCTION TO RECEIVERS

History of Communication (continued)

These simple signaling systems are at best slow and unreliable. If the wind is blowing from the wrong direction, sound signals will not be received. In thick fog or heavy rain, visual signals fail to deliver the message. Runners and pigeons are slightly more reliable, but their rate of travel is relatively slow.

The problem of rapid and reliable communication was solved by harnessing electricity to the task. Improvements on the inventions of Morse, Bell and Marconi have led to the development of modern telegraph, telephone and wireless communication systems capable of transmitting messages almost instantaneously over thousands of miles of space.

ELECTRICITY MADE COMMUNICATIONS RELIABLE AND RAPID

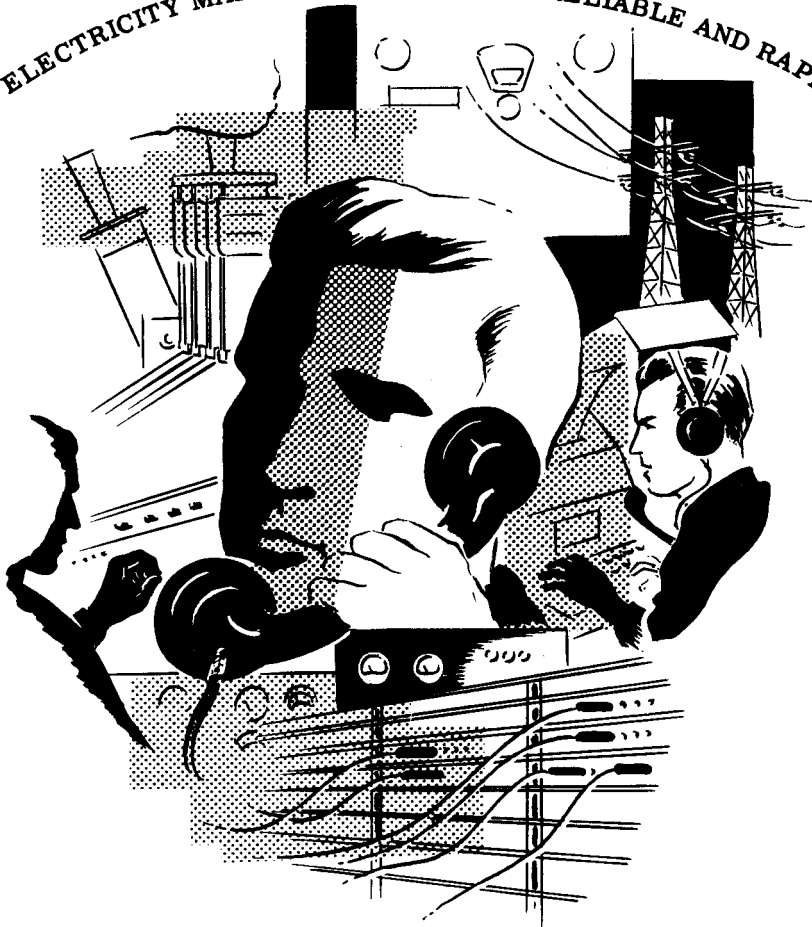

INTRODUCTION TO RECEIVERS

Modern Wireless Communication

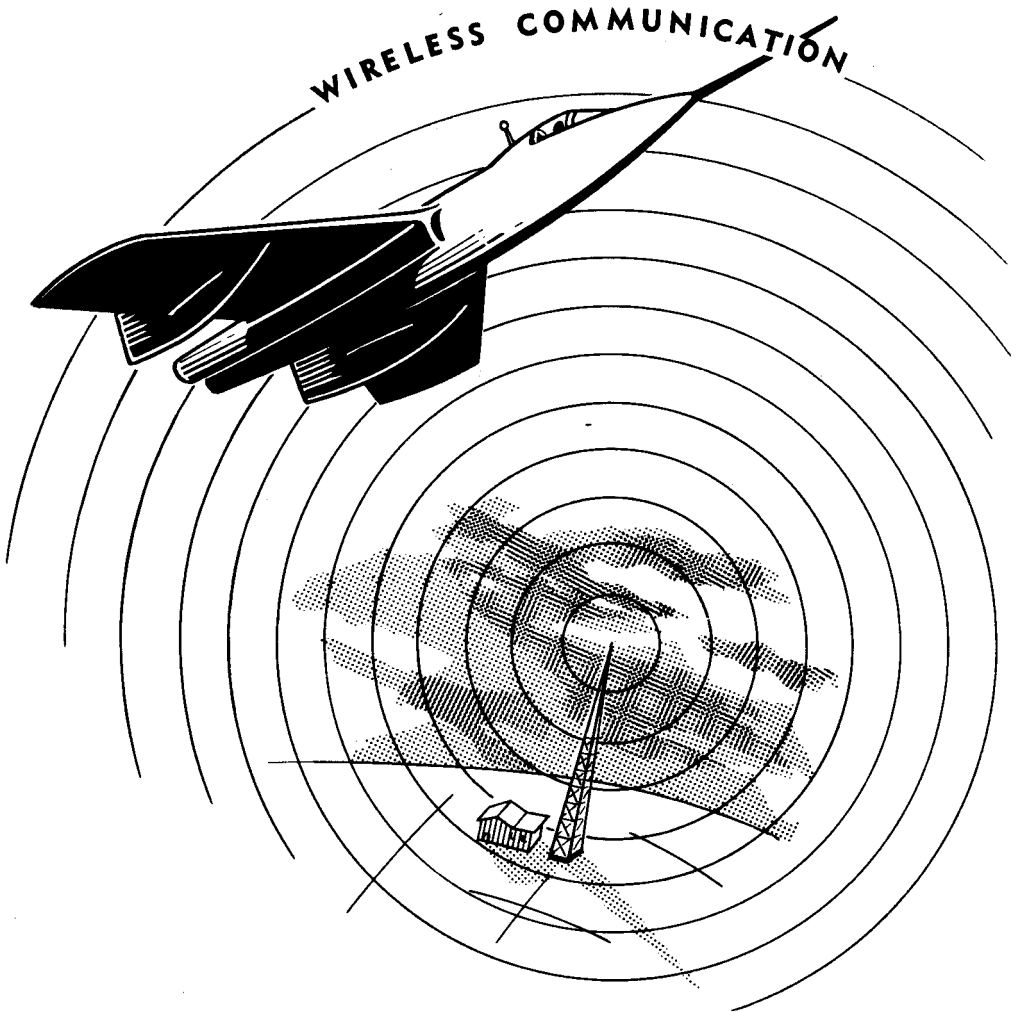

Today, with the advent of wireless communication, or as it is more commonly known—radio communication, the use of electricity for transmitting messages has reached its highest point. No longer is transmission limited to those places which a wire can reach, as is the case with telephone.

This remarkable electronic device, the radio, consists of two parts—the transmitter and the receiver. The transmitter sends out the message, in the form of radio waves, into the atmosphere. The radio receiver picks up the radio waves sent out by the transmitter, and converts them into the message which was originally put into the transmitter. This section will deal with the receiving end of radio communication—the receiver.

INTRODUCTION TO RECEIVERS

The Jobs a Receiver Performs

The jobs that a receiver must perform are very much the same in radio, radar and sonar equipment. Both the type of signal going into the receiver and the type of signal coming out of the receiver are different for each type of equipment; but the steps the incoming signal must go through before it emerges as a useful output are almost identical, whether the receiver is used for radio, radar or sonar. The function of any receiver can be broken down into five separate steps.

1. Picking up incoming signals: In radio and radar, the incoming signals are electromagnetic carrier waves sent out by a transmitter. When these waves cut across the receiving antenna, a very weak current is caused to flow. The current varies in frequency and amplitude to duplicate the signal radiated from the transmitter antenna.

In sonar, the "antenna" is an underwater microphone called a "transducer" which converts the incoming signal to a weak current flow and serves the same purpose as the radio and radar antennas.

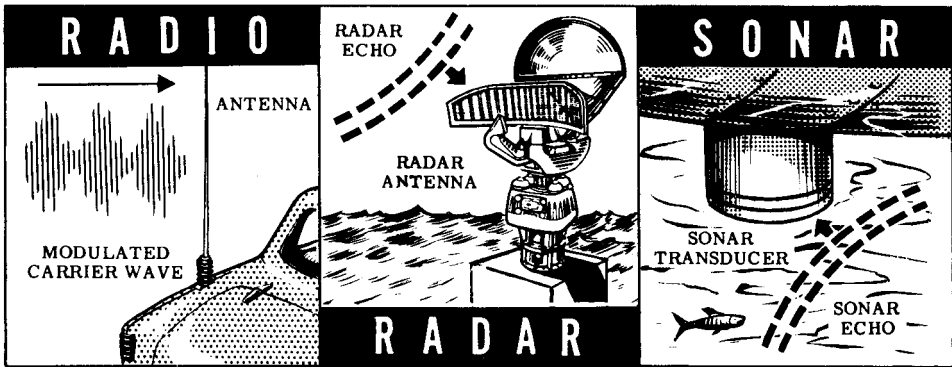

2. Selecting the desired signal: Many transmitters are sending out signals that reach the receiver antenna, and of these many signals, the receiver must be able to select the desired one. Each transmitter uses a different frequency, while the receiver contains circuits tuned to only the frequency that the operator desires to receive. The more tuned circuits used, the sharper the tuning. By tuning these circuits to the frequency of the signal of one of the transmitters, you can select that desired signal and reject all other signals.

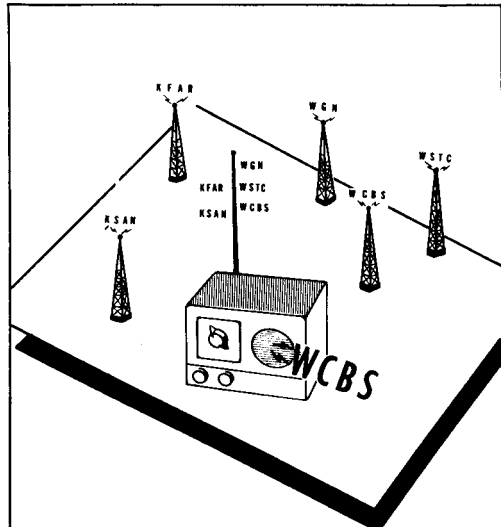

INTRODUCTION TO RECEIVERS

The Jobs a Receiver Performs (continued)

3. **Amplifying the desired RF signal:** The currents generated by the incoming signals in the antenna or transducer are extremely weak. RF amplifiers similar to those you have already studied are used to amplify these weak signals before they reach the detector.
4. **Detecting or demodulating the amplified signal:** A detector stage follows the last RF amplifier in a receiver. The detector does the important job of separating the "envelope" of the signal from the RF carrier. Because the envelope is the modulation of the signal, a detector is sometimes called a "demodulator." The signal, after demodulation, may be a voice or code signal as in communications radio receivers, or a sharp voltage rise and fall as in radar or sonar receivers.
5. **Amplifying the audio or video signals:** In radio receivers, the audio signal which comes from the detector undergoes further amplification. Audio voltage amplifiers and power amplifiers, similar to those you have already studied, build up the audio signal enough to operate a pair of earphones or a loudspeaker so that the signal may be heard.

In some sonar sets, the signal is heard in a loudspeaker, and the receiver is similar in design and operation to a radio receiver. In radar and certain other types of sonar receivers, the signal will show up as a "pip" on a 'scope. In these receivers, a video amplifier similar to those you have already learned about, would be used to amplify the voltage "pips." The video amplifiers take the signal from the detector and build it up so that it can be seen on the radar or sonar 'scope.

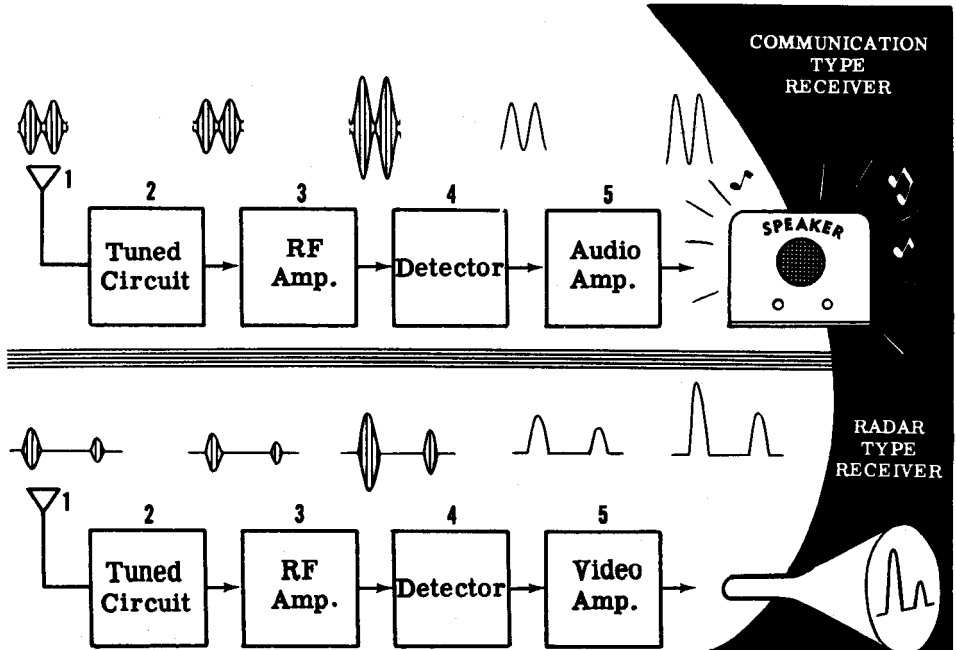

INTRODUCTION TO RECEIVERS

Receiver Sensitivity

There are several characteristics of a receiver which you can determine by simply comparing the input signal and the receiver output. These characteristics will tell you how well your receiver is working. The first of the characteristics—there are three in all—is sensitivity.

Sensitivity can be defined as the ability of the receiver to pick up weak signals, amplify them and deliver a useful output. No matter what type of equipment the receiver is in, sensitivity is important because many input signals which the receiver must amplify are extremely weak. Only a sensitive receiver can develop a sizable output with a weak input.

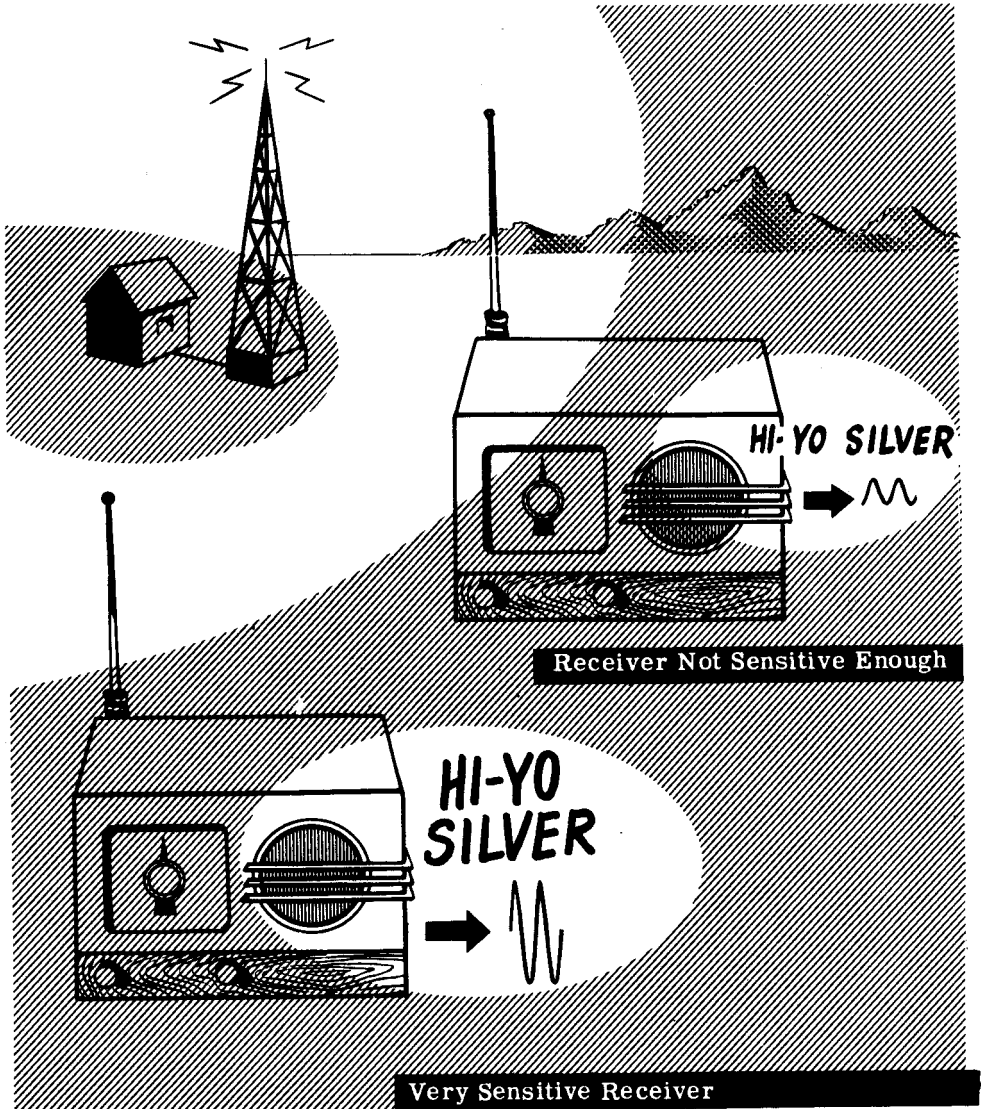

INTRODUCTION TO RECEIVERS

Receiver Selectivity

Sensitivity, by itself, does not make a receiver good enough for use. It must also be selective.

Selectivity is the ability of a receiver to select a desired signal and discriminate against all undesired signals. If every signal which struck the antenna were amplified, the output, although strong enough, would be worthless because of all the interference caused by the presence of the undesired signals.

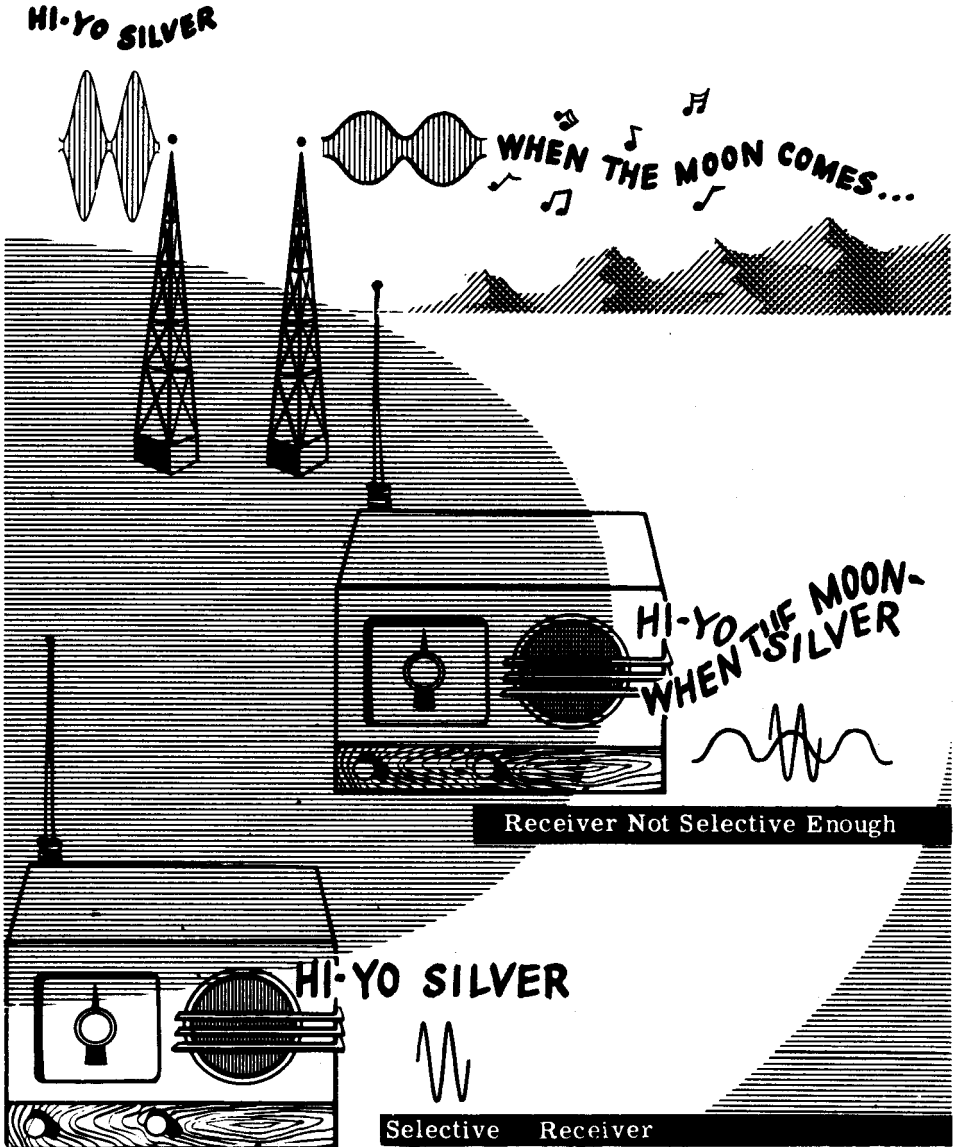

INTRODUCTION TO RECEIVERS

Fidelity

For some applications, if the receiver can pick out one signal from the many which strike the antenna (selectivity) and can amplify it so as to produce a useful output even though the signal may be weak (sensitivity), the receiver is good enough to be used. For other applications, one more thing is important—the receiver must be able to reproduce the incoming signal without distortion. A receiver which can do this is said to have "good fidelity"; a receiver which cannot, has "poor fidelity."

Home radio receivers usually have good fidelity since they are made for enjoyment. Communications receivers are made to duplicate voice, but only so that it is intelligible, and are therefore not usually designed with good fidelity in mind. Sonar and radar receivers, on the other hand, have good fidelity because the operator gets a great deal of information from the sound or 'scope appearance of the receiver output.



The Crystal Receiver

The first receivers were used in the early 1900's and were called "crystal sets." In their simplest form, they consisted of an antenna, a crystal detector, a "cat's whisker" and a pair of earphones.

The antenna picked up any signals in the air—in those days there were very few—and the crystal (which operated as a rectifier) allowed the antenna currents to flow directly to ground on every positive half cycle of RF, but blocked the negative half cycles. These positive half cycles of current flowed through the "cat's whisker," a delicate wire contact on the crystal, to the earphones where weak sounds sometimes were heard. Crystal sets at best had one tuned circuit before the crystal, but even so, the selectivity was very poor. Because no vacuum tubes were used, the sensitivity was so bad that crystal sets could not be used very far from a transmitting station. Today these sets are curiosities, and have no practical applications.

IN THE BEGINNING...

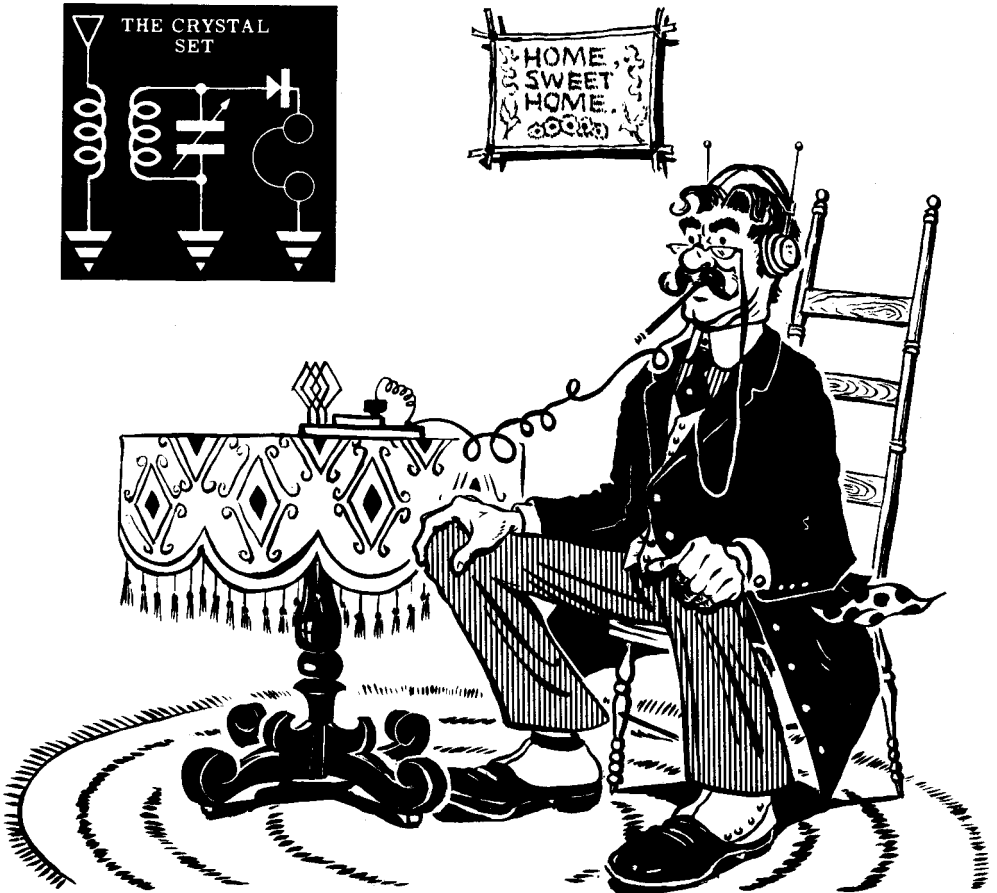
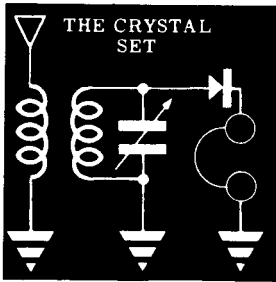

The TRF Receiver

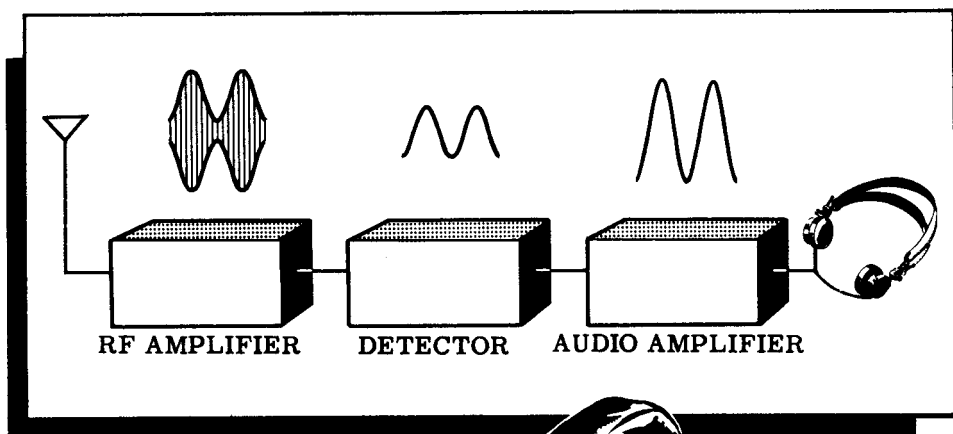

TRF



By 1920, crystal sets were on their way out and were being replaced by tuned radio frequency (TRF) receivers, which made use of vacuum tubes. The first few vacuum tubes, and their tuned circuits, make up the RF amplifier which gives the TRF receiver better selectivity and sensitivity than the old crystal sets. The detector does the same thing as the crystal detector and sometimes amplifies the signal as well. After the detector, the audio signal is amplified in the audio amplifier. The output of the audio amplifier is a fairly powerful signal which can be used to drive a loud-speaker or a pair of earphones. TRF receivers are not used very often today, but some receivers are still of this type.

INTRODUCTION TO RECEIVERS

The Superheterodyne Receiver

The most common type of receiver used in home radios and in other equipment is the superheterodyne receiver. In this type of receiver, all the RF amplification does not take place at the incoming signal frequency. Most of the RF amplification occurs after the incoming signal has been converted to an intermediate frequency (IF), which is always the same no matter what the frequency of the desired signal is. You will see how this is accomplished later.

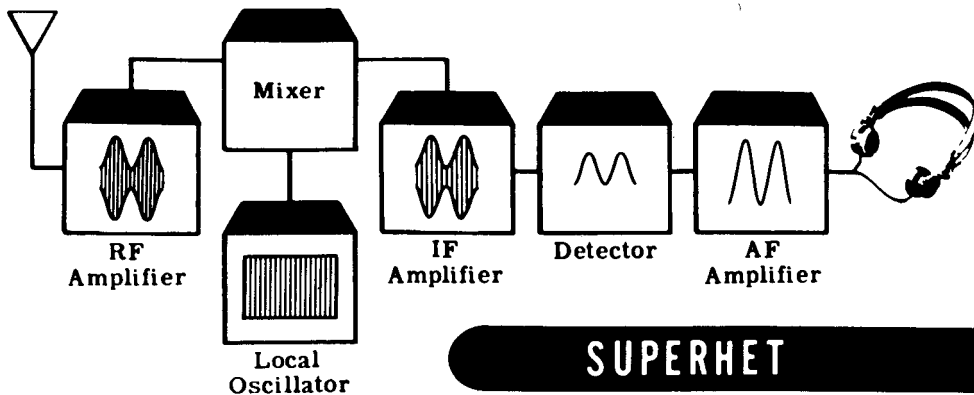

The only parts in a superhet which differ from those in a TRF are the variable frequency local oscillator, the mixer and the IF amplifier. The variable frequency local oscillator is similar to the oscillators with which you have already worked. The oscillator produces a pure RF signal which is "mixed" in the mixer stage with the signal from the RF amplifier. The resulting IF frequency is the difference between the input signal frequency and the local oscillator frequency. The IF is a fixed frequency and the IF amplifiers are therefore fixed-tuned. This allows them to be very accurately tuned so that high gain and selectivity can be obtained at the chosen frequency.

You will find out exactly how a superhet receiver works a little later in this section. For the time being, it is enough for you to know that the advantage of the superhet over the TRF receiver is that the superhet has higher gain and greater selectivity.

INTRODUCTION TO RECEIVERS

Recently Developed Uses of Receivers

Receivers play a very important role in the relatively new field of television, which finds wide application both in the civilian and military field.

Every home television set has at least two receivers. One receiver is designed to change part of the incoming signal into sound, while the other converts the remainder of the signal into a picture or image which appears on a screen.

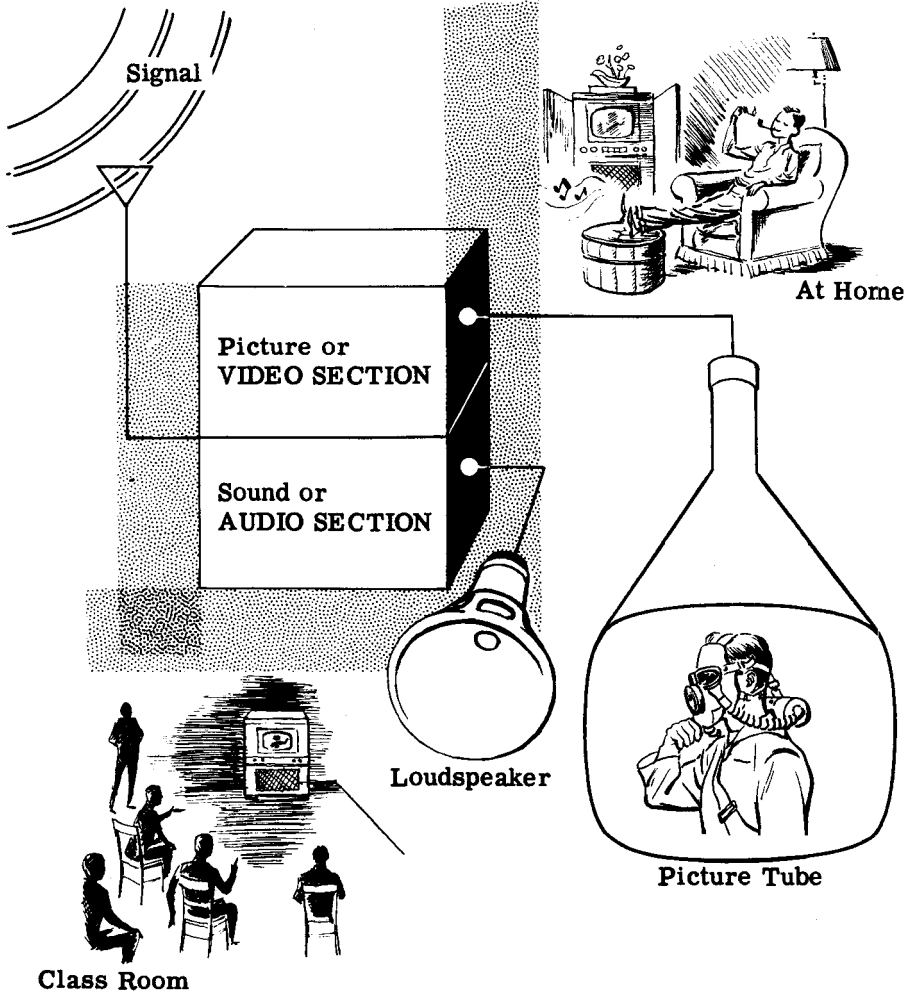

We are all aware of television as a source of entertainment. Another application, designed for improving and enriching training programs, involves the use of televised demonstrations. These demonstrations may be observed simultaneously in dozens of classrooms.

INTRODUCTION TO RECEIVERS

Recently Developed Uses of Receivers (continued)

Airborne television equipment can be used to transmit an overall survey of localized operations back to a flagship or to headquarters.

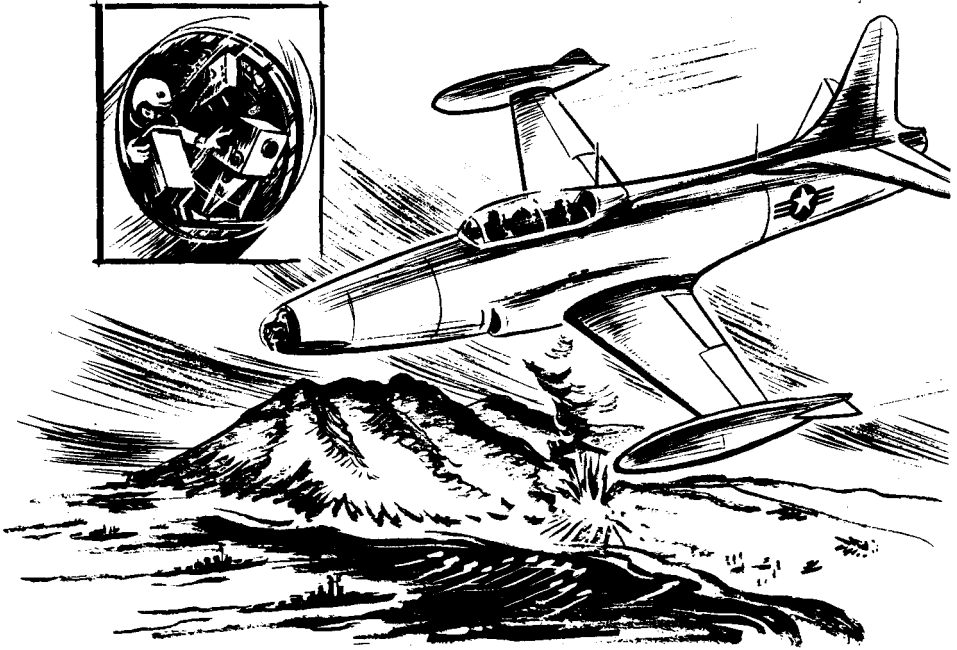

One of the most interesting and significant applications of radio reception to modern warfare is in connection with the development of guided missiles. The path followed by these missiles can be controlled by radio signals transmitted by a distant operator.

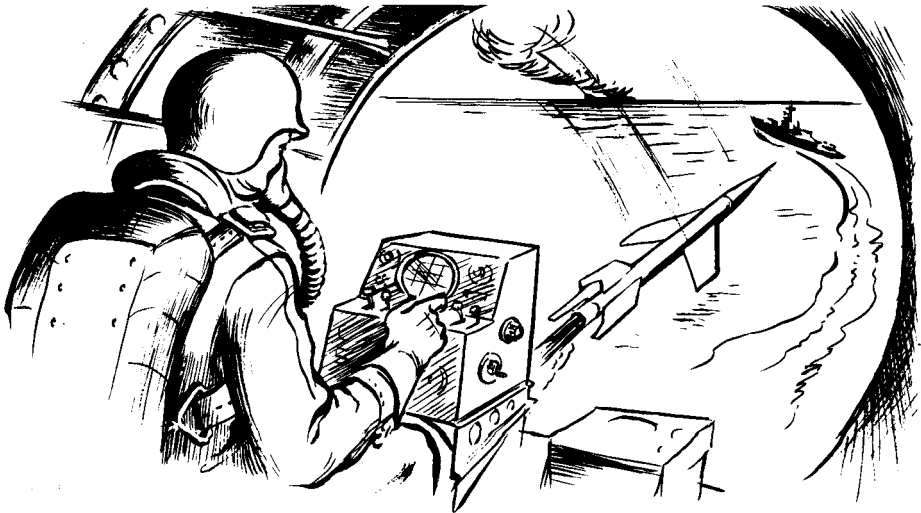

RECEIVER ANTENNAS

The Function of Receiver Antennas

The purpose of the receiver antenna is to intercept the electromagnetic waves radiated from the transmitter. When these waves cut across the antenna, they generate a small voltage in it. This voltage causes a weak current to flow in the antenna-ground system. This feeble current has the same frequency as the current in the transmitter. If the original current in the transmitter is amplitude modulated, the antenna current will vary in exactly the same manner. This weak antenna current, flowing through the antenna coil, induces a corresponding signal in the grid circuit of the first RF amplifier stage of the receiver.

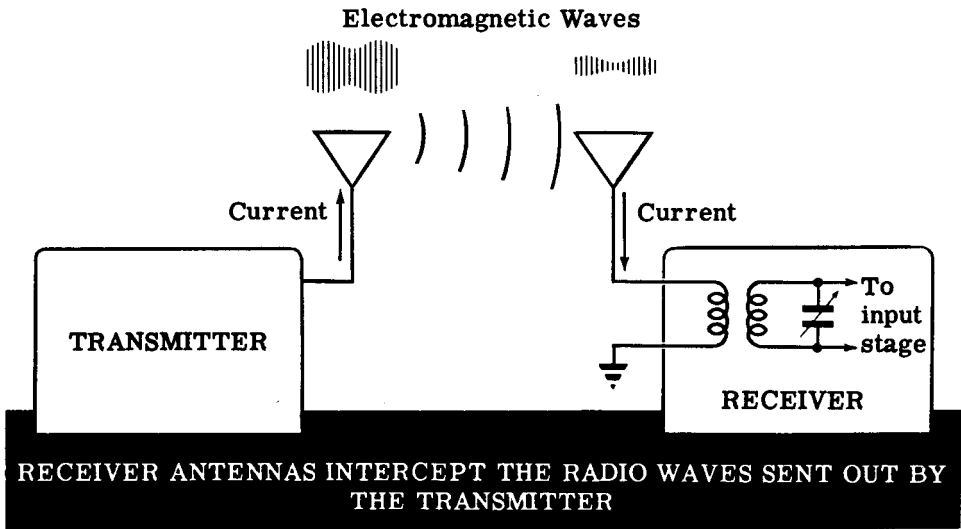

A receiving antenna should feed as much signal and as small an amount of undesired interference to the receiver as possible. It should be constructed so that the signal is not lost or dissipated before reaching the receiver. It should give maximum response for the frequency or band of frequencies to which the receiver is tuned. An antenna can also be directional, which means that it will give best response in the direction from which the operator wishes to receive.

The receiver antenna problem is easily solved when the receiver is operated in conjunction with a transmitter. Since the transmitting antenna is usually designed to incorporate the desirable features which have just been listed, the same antenna is used for both transmitter and receiver. A switch or relay is used to connect the antenna to the piece of equipment that is operating at that particular moment. However, when no transmitter antenna is available it may be necessary to erect a separate receiving antenna, paying attention to the four considerations of noise, signal loss, frequency response and directivity. Before discussing these considerations of antenna design, it might be a good idea to become familiar with a few of the more common types of receiving antennas.

RECEIVER ANTENNAS

Types of Receiver Antennas

One of the simplest and most commonly used antennas is the inverted L. It consists of a wire, known as a "flat-top," which is suspended horizontally between two insulators. The length of the wire should be from 50 to 75 feet for broadcast-band reception and from 20 to 40 feet for high-frequency reception. The flat-top should be suspended from 30 to 50 feet above the ground. A wire known as the "lead-in" is used as a transmission line from the antenna to the receiver. It is connected near one end of the flat-top and brought down to the primary winding of the receiver antenna coil.

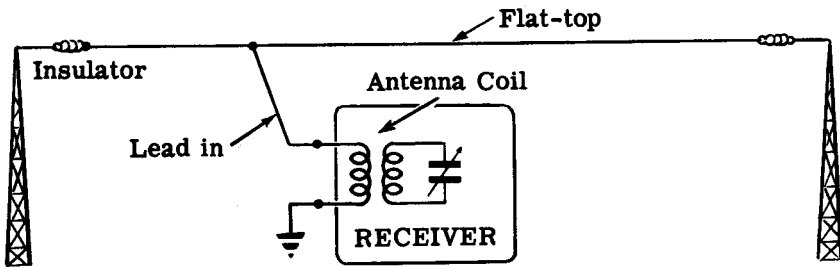

INVERTED L ANTENNA

Another common type of antenna is the doublet or dipole antenna. It consists of a horizontal wire divided into two equal sections by an insulator. Each half of the antenna should be a quarter wave long for the frequency band most commonly used. The transmission line from the antenna is connected to the two ends of the primary of the antenna coil.

This type of antenna will give excellent high-frequency response and will also give comparatively noise-free reception on the broadcast band. It may be of interest to note that most television receiver antennas are modifications of the dipole antenna, with metal bars replacing the less rigid wires.

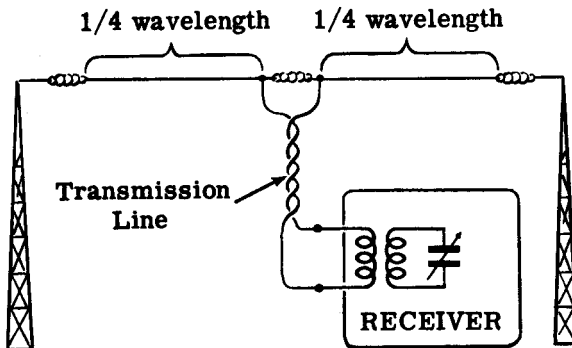

DIPOLE ANTENNA

RECEIVER ANTENNAS

Types of Receiver Antennas (continued)

Where lack of space makes horizontal antennas impractical, a vertical antenna is used. Vertical antennas, consisting of telescoping metal masts from 3 to 14 feet in length, are commonly used for automobile and portable receivers, and sometimes for home broadcast receivers. An ordinary lead-in wire is run from the bottom of the antenna to the primary of the antenna coil of the receiver. The other end of the primary should be grounded.

VERTICAL ANTENNA

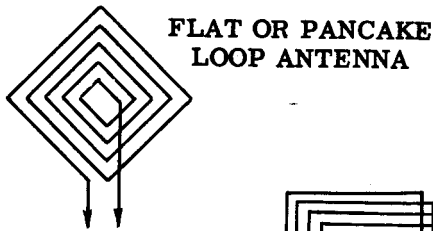
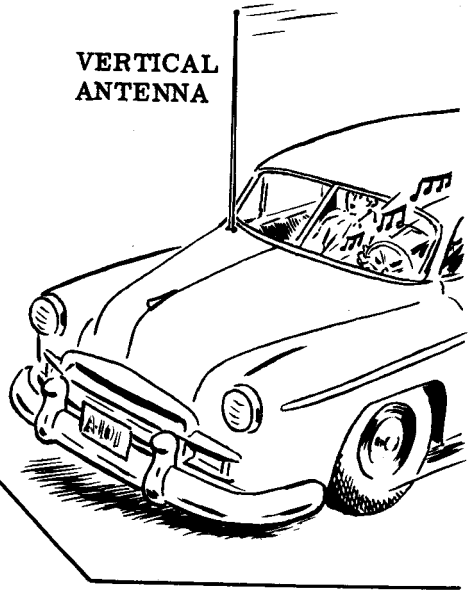

FLAT OR PANCAKE LOOP ANTENNA

BOX LOOP ANTENNA

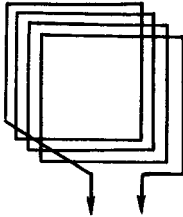

Another type of antenna used for portable and home receivers is the loop antenna. The loop consists of a coil of wire which is connected to the two ends of the primary of the antenna coil. Most home broadcast-band receivers contain a loop antenna within the cabinet.

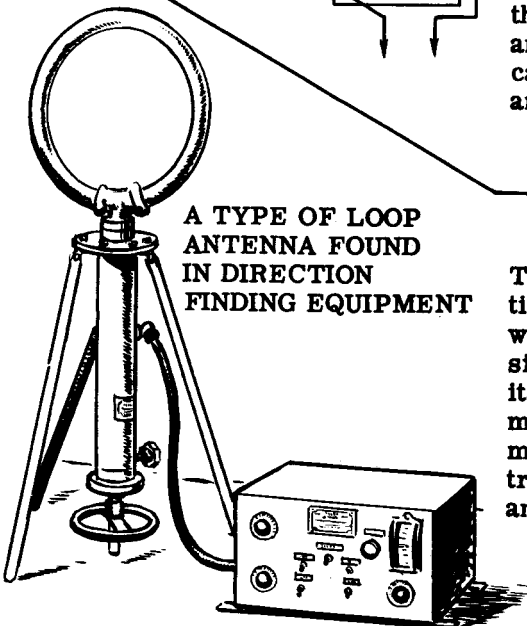

A TYPE OF LOOP ANTENNA FOUND IN DIRECTION FINDING EQUIPMENT

The loop antenna is highly directional. When it is pointed edge-wise toward a transmitter, the signal pickup is maximum; when its flat side is toward the transmitter, the signal pickup is minimum. This property makes it extremely useful for radio-beacon and direction-finding equipment.

RECEIVER ANTENNAS

Considerations in Selecting and Installing an Antenna—Noise

An important consideration in antenna installation is that of noise. Noise consists of radio waves of many frequencies and is produced by both man-made and natural electrical disturbances. Among the more important man-made noise producers are elevators, fans, refrigerators, automobile ignition systems, vacuum cleaners, X-ray and diathermy equipment, and power lines.

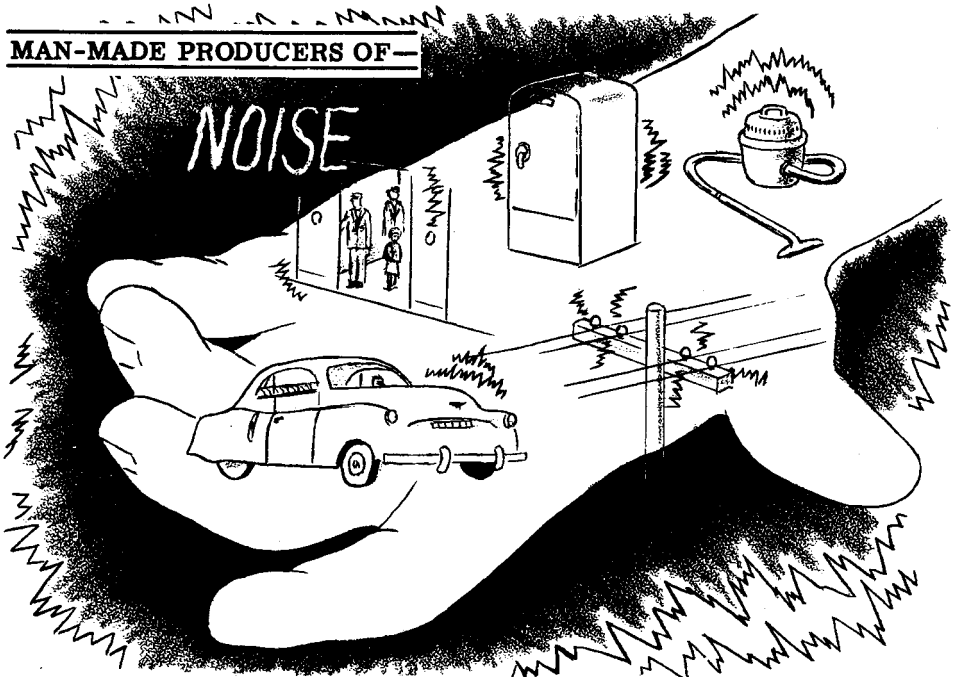

The antenna cannot differentiate between desired signals and undesired radio noise. It is customary to compare the signal pickup of the antenna with the noise pickup. This relationship is known as the "signal-to-noise ratio." A high signal-to-noise ratio is necessary if one desires to obtain relatively noise-free reception.

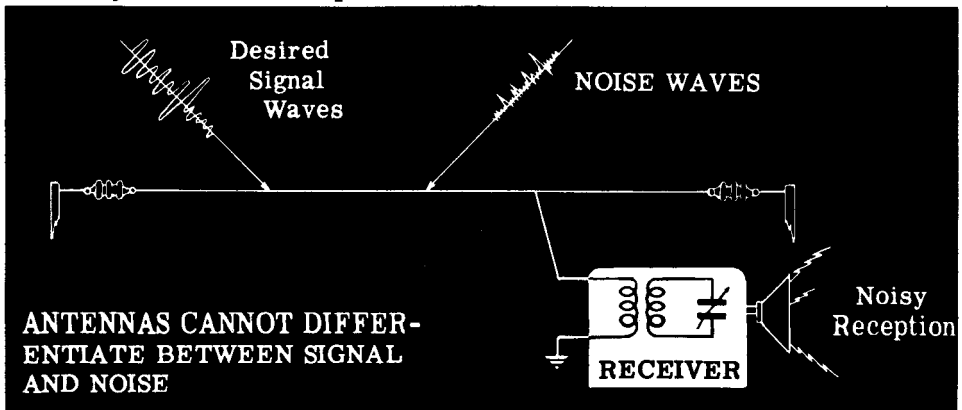

RECEIVER ANTENNAS

Considerations in Selecting and Installing an Antenna—Noise (continued)

There are various ways by which a high signal-to-noise ratio may be obtained. The first method is by locating the antenna as far as possible from elevator shafts, street car and power lines and other devices likely to produce noise. Placing the antenna at right angles to the power line will also reduce the amount of noise.

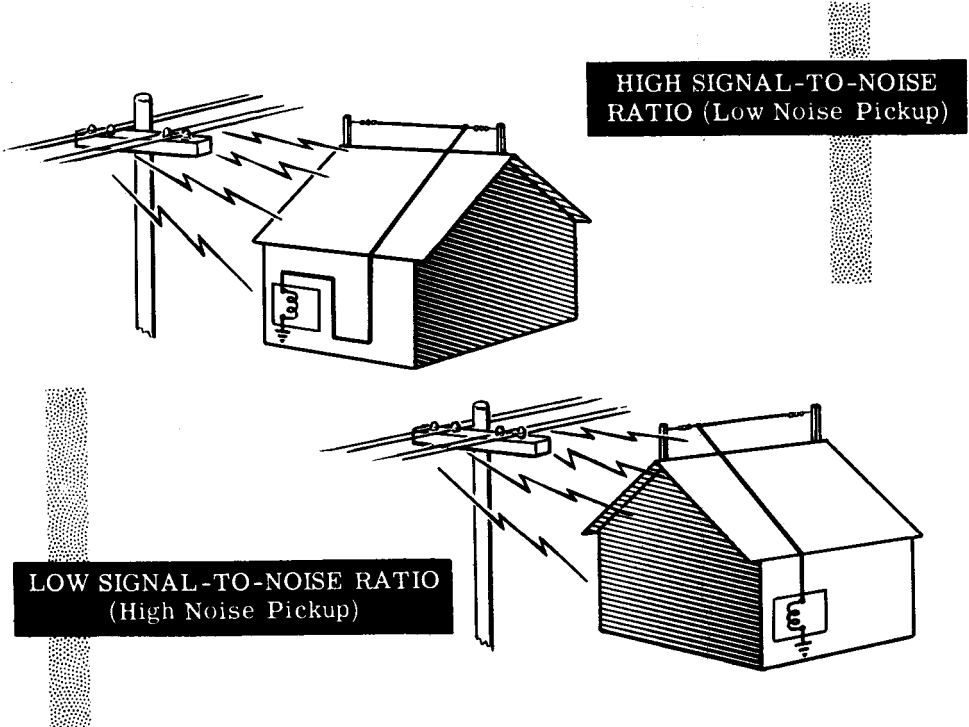

The second method is by increasing the height of the antenna as much as practical considerations will allow. This tends to increase the signal strength and reduce the amount of noise.

The third method involves using a good ground connection to the receiver when provision is made for one. A poor ground lead may pick up noise; therefore, it should be as short as possible and away from noise-producing devices. A good ground lead should use rubber-insulated wire, size No. 14 or larger. It should make good contact through a ground clamp to a grounded object, such as a radiator or water pipe. Gas pipes should never be used for grounding purposes.

A good deal of noise may be picked up by the lead-in. If the lead-in uses two wires, as in the case of the transmission line used with a doublet antenna, noise can be reduced by using twisted wires or by reversing the positions of the wires every few feet. Noise can also be reduced by using shielded lead-in wires.

RECEIVER ANTENNAS

Considerations in Selecting and Installing an Antenna—Signal Losses

The second factor to be considered in selecting and installing an antenna is that of signal losses. The antenna should be placed as far as possible from metal objects, chimneys, walls, and tree branches which absorb radio waves and thus reduce the strength of the signal reaching the antenna. A loose or swinging antenna may cause the signal to fade.

FACTORS THAT CAUSE ANTENNA SIGNAL LOSSES...

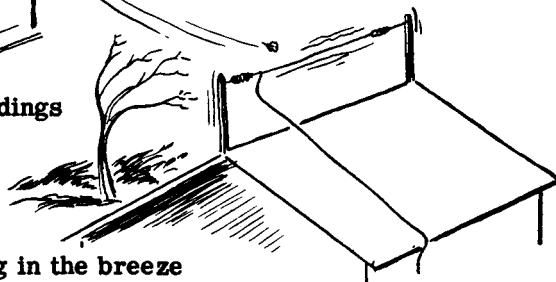
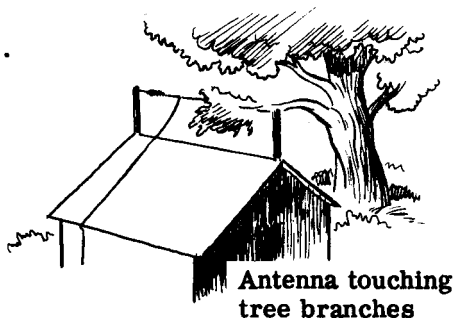
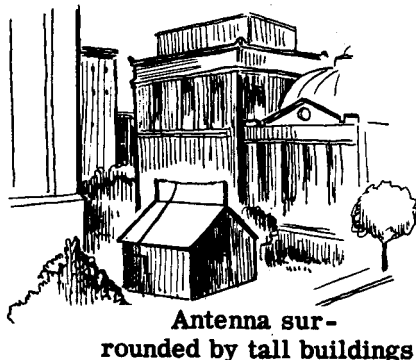

Signal losses will also be increased if a high resistance is present in the antenna circuit. To reduce resistance, all joints and connections should be carefully soldered and, wherever possible, the antenna and lead-in should consist of a single piece of wire with no joints.

Signal losses may be further increased by leakage of current through poor supporting insulators. These insulators should be made of materials such as glazed porcelain or pyrex glass, which do not readily absorb moisture and thus provide a leakage path for current.

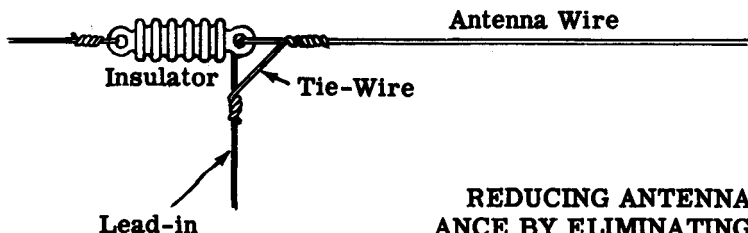

REDUCING ANTENNA RESISTANCE BY ELIMINATING JOINTS

RECEIVER ANTENNAS

Considerations in Selecting and Installing an Antenna— Frequency Response and Directivity

The third consideration is that of frequency response which is related to the antenna length. A maximum signal, at a given frequency, will be induced in the antenna if it is one-quarter or one-half the wavelength of the signal to be received. If desired, it is possible to change the effective length of an antenna by placing a coil or capacitor in series with it. Adding inductance increases the electrical length of the antenna, while adding capacity shortens it. The front panel of certain receivers contains a control marked ANT. COMP. (antenna compensation). This control varies the size of a small capacitor and is used to compensate for variations in antenna length. In general, adjustment of the antenna to the correct length is not nearly as important or critical for receiving equipment as for transmitters.

The final consideration is that of directivity. All antennas, except the vertical type consisting of a single perpendicular wire, have a directional effect and receive signals from certain directions better than from others.

A horizontal or inverted L antenna will receive best when the signal cuts the antenna wire at right angles. For any one station the antenna may be turned so that it produces the maximum signal pickup. However, since it is extremely unlikely that all transmitters will be broadcasting from the same direction, the placement of the antenna will probably be a compromise for all stations.

The directional effects of the loop antenna have already been discussed and need not be repeated. Dipole antennas may be made highly directional by arranging them into systems called "arrays," similar to those employed with television systems.

FACTORS TO BE CONSIDERED IN SELECTING AND INSTALLING ANTENNAS. . .

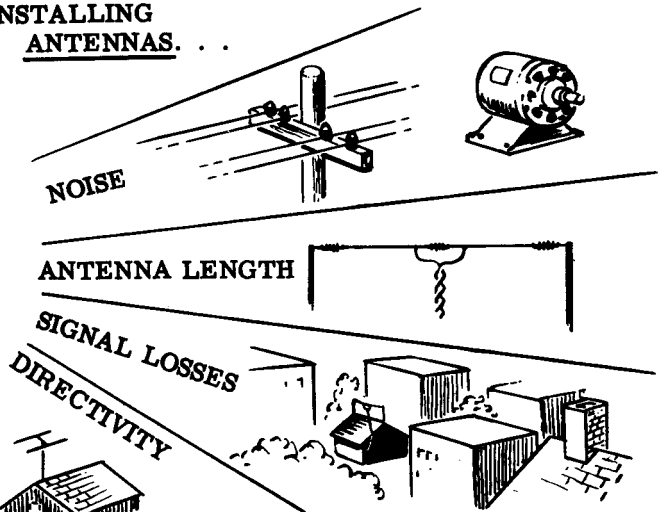

RECEIVER ANTENNAS

Review of Receiver Antennas

ANTENNA FUNCTION—The receiver antenna picks up signals radiated by a transmitter, and transmits these signals—via the lead-in or transmission line—to the primary of the receiver antenna coil. The electromagnetic waves cutting the antenna induce voltages, thus causing currents to flow which are amplified by the receiver.

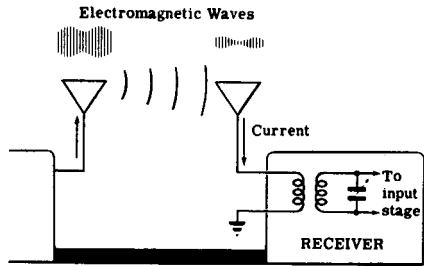

INVERTED L ANTENNA—This is one of the simplest and most commonly used types of antennas, consisting of a horizontally supported wire, with the lead-in attached near one end.

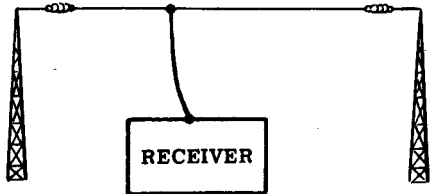

DIPOLE ANTENNA—This type of antenna is the same as is used in transmitters, and consists of two quarter wavelength sections supported horizontally. It gives excellent high-frequency response.

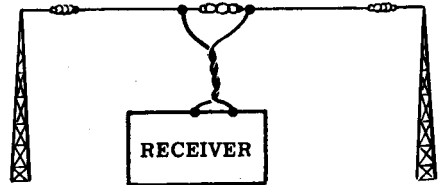

LOOP ANTENNA—The loop antenna is used with many portable and home broadcast-band receivers. Because it is highly directional, it is also used in direction-finding equipment.

FLAT OR PANCAKE LOOP ANTENNA



BOX LOOP ANTENNA

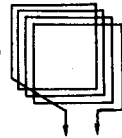

SELECTION AND INSTALLATION—Noise, signal loss, frequency response and directivity are the four factors which must be considered when selecting and installing an antenna.

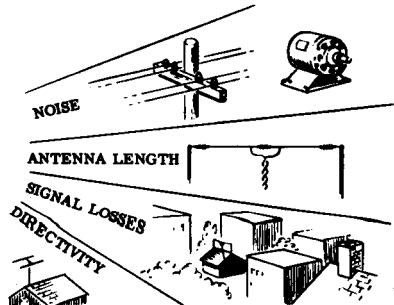

TRF RECEIVERS—RF AMPLIFIER STAGE

The TRF Receiver

The TRF receiver is the type of receiver you will study first. You will recall from "Introduction to Receivers" that the TRF consists of an RF amplifier, a detector and an audio amplifier.

So that you may have in mind the goal toward which you are working, shown below are the circuit diagrams of the two TRF receivers you will learn about.

TRF RECEIVER WITH A REGENERATIVE DETECTOR

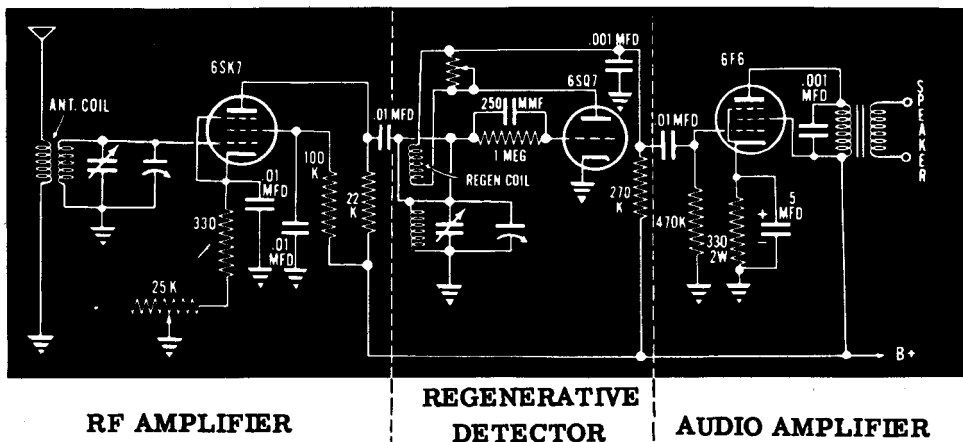

TRF RECEIVER WITH A PLATE DETECTOR

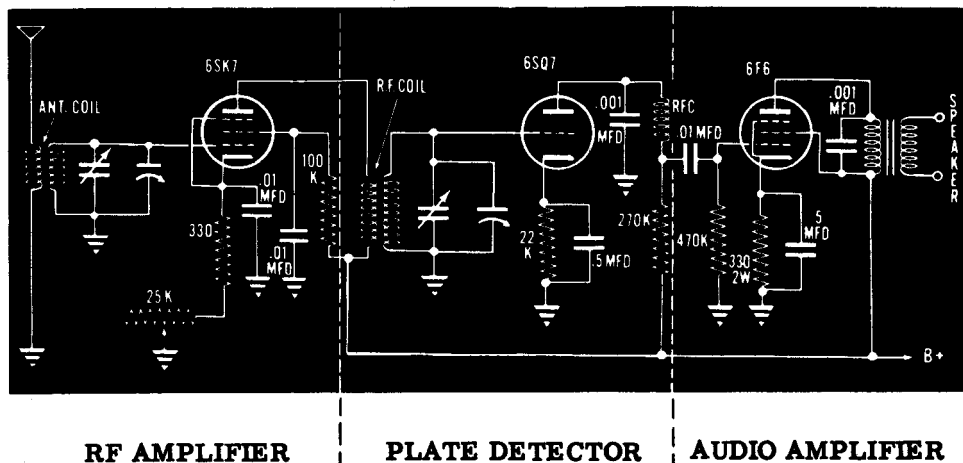

TRF RECEIVERS—RF AMPLIFIER STAGE

The RF Amplifier Stage

Every TRF receiver contains one or more stages of RF amplification preceding the detector. The main purpose of these amplifiers is to provide additional selectivity and sensitivity. You will recall that selectivity indicates how well a receiver receives a desired signal and rejects unwanted signals, and that sensitivity is a measure of the receiver's ability to pick up a weak signal. In general, the more RF amplifier stages used, the greater will be the selectivity and sensitivity. On this and the following few sheets you will review some of the outstanding points about RF amplifiers.

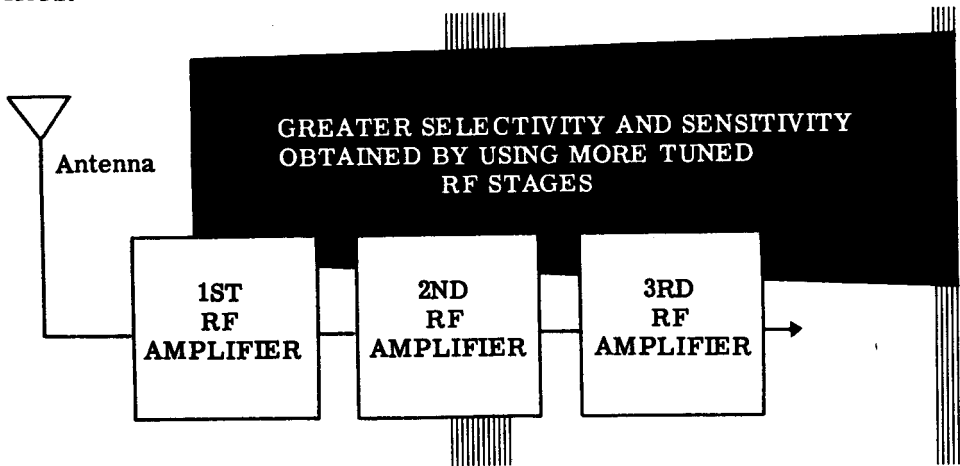

Since the RF amplifier stage is designed primarily for voltage amplification, any tube suitable for voltage amplification may be used. However, triodes are not considered satisfactory because they have a strong tendency to produce undesirable oscillations when employed in RF amplifier stages. Unless the triodes are carefully neutralized to prevent feedback, the oscillations produced are likely to cause considerable trouble.

Tubes containing a screen grid do not suffer from this disadvantage and as a result, most RF amplifiers found in receivers employ either tetrodes or pentodes. The tube which is generally preferred as an RF amplifier is a variable- μ pentode. The use of this type of tube not only provides for considerable voltage gain, but also minimizes certain types of interference from powerful undesired signals. Since varying the grid bias of a variable- μ pentode changes the amount of amplification, this type of tube lends itself admirably to applications in circuits involving manual volume control or automatic volume control.

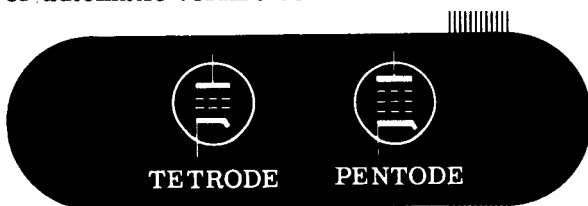

Only screen grid tubes are used in receiver RF amplifiers

TRF RECEIVERS—RF AMPLIFIER STAGE

RF Transformers

In the schematic of an RF amplifier stage shown below, you will note that the RF amplifier has two RF transformers. The first, the antenna coil, is designed to couple the antenna circuit to the grid circuit of the amplifier. The second, often referred to as the RF coil, couples the plate circuit of the RF amplifier with the grid circuit of the next stage.

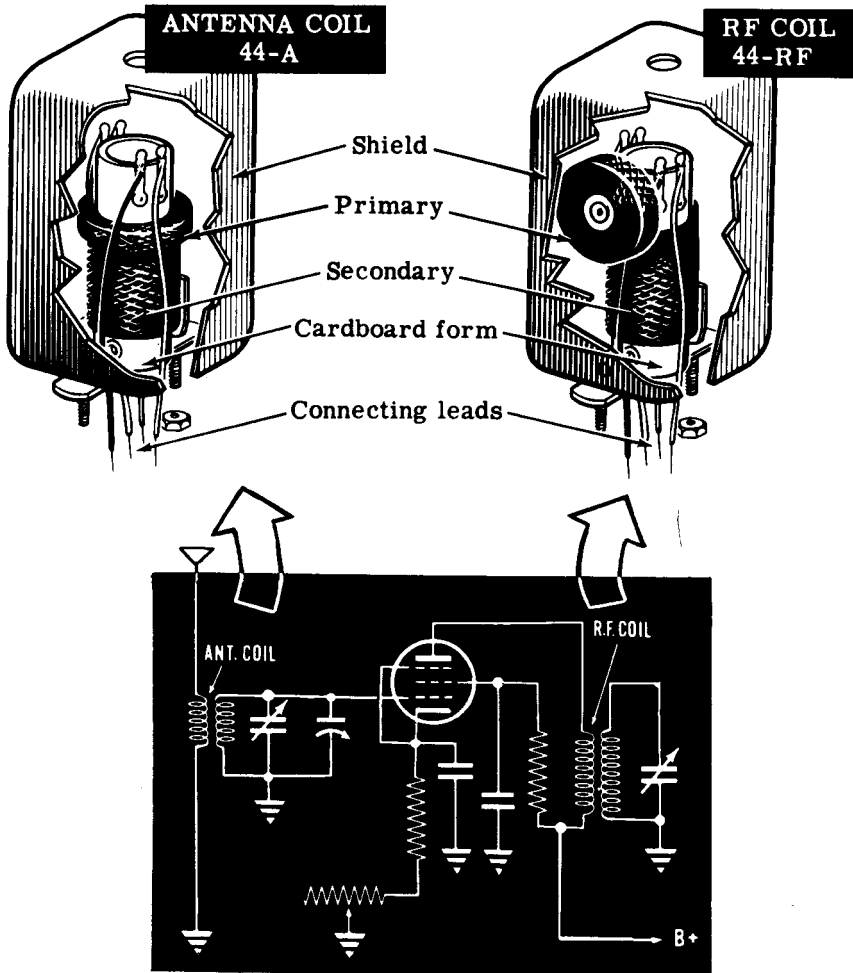

The coils are usually wound on a form made of cardboard or bakelite. They are generally of the air core type, although occasionally, when the frequency of operation is not too high, powdered iron cores may be employed.

RF Transformers (continued)

RF transformers used for broadcast band reception have relatively large primary windings which tend to resonate at low frequencies and produce greater gain at the low end of the dial. To compensate for this, capacitive coupling between primary and secondary is used to increase the gain at the high frequency end of the dial. This is accomplished during the manufacture of the coil, by connecting a small capacitor of from 3 to 10 mmfd capacity between the primary and secondary windings, or by using a loop of wire, known as a "gimmick" or "capacity turn." This wire is connected to the primary and is wrapped around, but insulated from, the secondary.

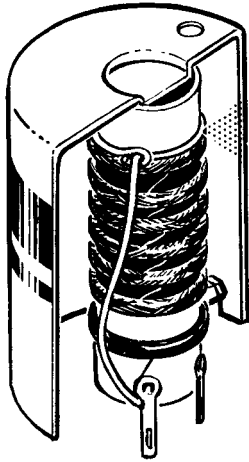

the
Gimmick

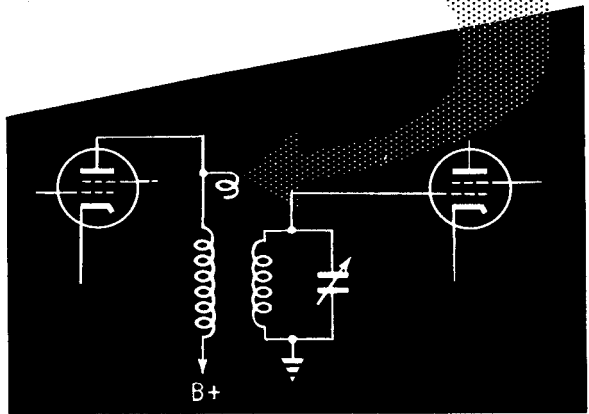

Perhaps you will recall some references, made in "RF Amplifiers," to the "Q" of a resonant circuit. This Q, which is equal numerically to the reactance of the coil divided by its resistance, determines both the selectivity and voltage gain that can be obtained from a resonant circuit. In order to keep the selectivity high, it is therefore necessary to use RF transformers whose resistance is fairly low.

Another important consideration is that of shielding. Unless RF transformers are shielded by means of copper or aluminum shields grounded to the chassis of the receiver, there probably will be undesirable coupling and the production of unwanted oscillations. It should also be noted that shielding changes the inductance and Q of a coil. Consequently any receiver adjustments, such as the alignment process which will be described shortly, should be performed with the shields in place.

TRF RECEIVERS—RF AMPLIFIER STAGE

Band Switching

You will note that while the primaries of these transformers are untuned, variable capacitors are connected across the secondary coils, thus forming resonant or tuned circuits. These resonant circuits are responsible for the high selectivity and sensitivity of the TRF receiver.

If a receiver is to cover a frequency range greater than one coil and one tuning capacitor will allow, it will be necessary to change the tuning circuits. This is usually accomplished by substituting a different coil. One system uses removable plug-in coils, while another system uses several mounted coils whose leads run to a multicontact rotary switch, known as a "selector" or "band switch." By turning the switch, any coil may be connected to the tuning capacitor and thus provide a satisfactory response for any desired band of frequencies.

A good example of a receiver employing band switching is shown below. In this receiver the selection of the frequency band is accomplished by rotating a four-position switch. Each switch section can connect any one of four RF coils to a variable capacitor.

BAND SWITCHING

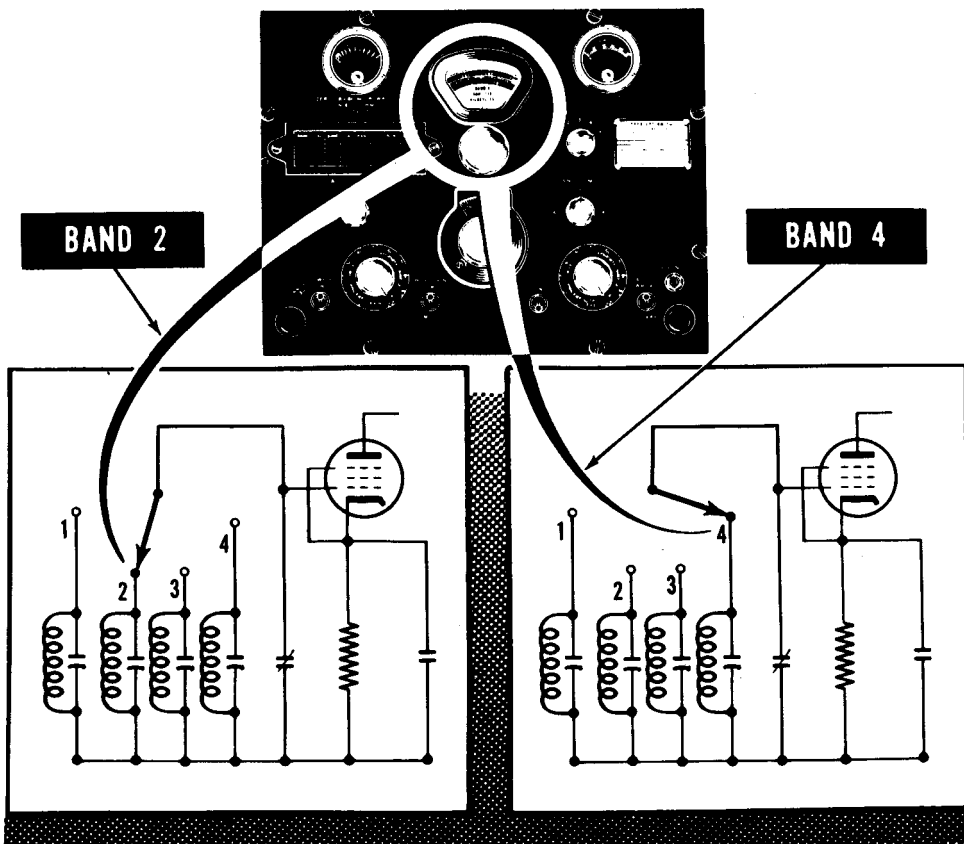

TRF RECEIVERS—RF AMPLIFIER STAGE

Ganged Capacitors and Alignment

Every TRF receiver has a minimum of two tuned circuits, one associated with the RF amplifier and one with the detector. In the early days of the TRF, each variable capacitor in the tuned circuit was connected to its own individual tuning knob. In order to tune your radio to a station, you had to turn each knob individually until each tuned circuit was resonant to the frequency of the desired station.

The modern TRF receiver eliminates the need for individual tuning knobs by having the variable capacitors of all the tuned circuits mounted on one shaft. This allows the receiver to be tuned with a single control which varies all the tuned circuits together and at the same time. This is called "ganged" tuning. In a receiver having two RF amplifier stages plus a detector, a three-gang capacitor would be used.

Since all of the tuned circuits are varied together, all of the variable capacitors should have exactly the same capacity, at the same time, for various settings. All of the tuned circuits would then be resonant to the same frequency at the same time—resulting in maximum sensitivity and selectivity.

Unfortunately, no two capacitors can be manufactured exactly alike, and therefore the individual capacitor sections on a ganged unit will have slightly different capacities at every setting. If nothing were done to compensate for these differences in capacity, the tuned circuits in a receiver would be resonant to slightly different frequencies for every setting of the tuning knob—causing poor receiver selectivity and sensitivity. Such a receiver is said to be "out of alignment."

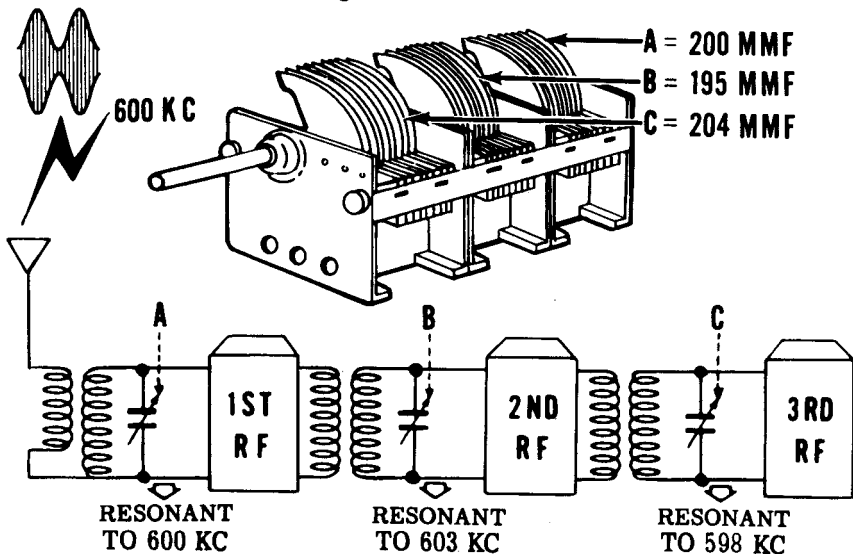

RECEIVER OUT OF ALIGNMENT

TRF RECEIVERS—RF AMPLIFIER STAGE

Trimmer Capacitors and Coils

The problem of misalignment can be solved by adding small variable capacitors, called "trimmer capacitors," in parallel with the main variable tuning capacitors.

Sometimes the adjustment is made in the coil of a tuned circuit rather than on the capacitors. In this case, an iron-cored slug is moved in and out of the coil, causing the inductance to vary. This is called "slug tuning."

In receivers covering only one band, the trimmers are usually located on the ganged capacitors, one for each section. In receivers using band switching, the trimmers for each range are usually mounted on, and in parallel with, the individual coils. These trimmer capacitors are adjusted after the main capacitors have been set at minimum capacity at the high end of the dial. They are adjusted to make the total capacity of the individual tuned circuits the same at every setting of the tuning control. The tuned circuits will, therefore, be tuned to the same frequency, simultaneously, all over the band—resulting in high receiver sensitivity and selectivity.

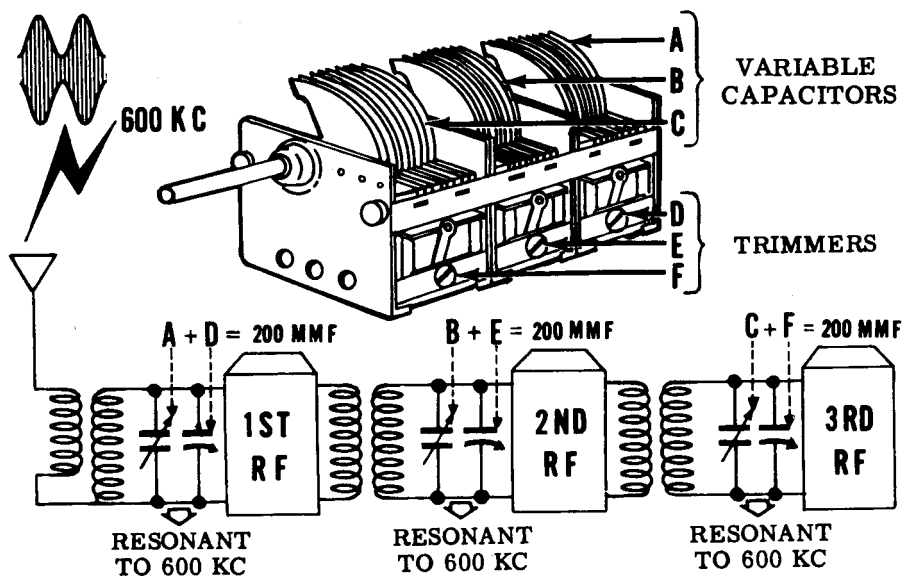

RECEIVER IN ALIGNMENT

It sometimes happens that although the circuits are properly adjusted at the high end of the dial, they may not tune to identical frequencies at the other end of the dial. A correction may be made for this, in some sets, if the end rotor plates are of the slotted type. Adjustments can be made by bending a portion of the slotted plates toward, or away from, the stator plates. When all of the stages tune to identical frequencies at all dial settings, they are said to be "tracking" and the receiver is in alignment.

TRF RECEIVERS—RF AMPLIFIER STAGE

Grid Bias Manual Volume Control

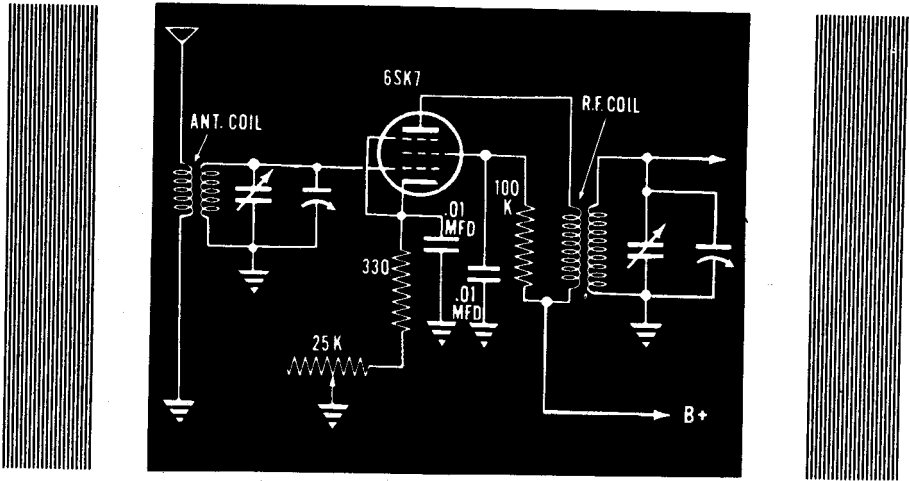

Since signals arriving from different transmitters will vary in intensity, it is necessary to provide a volume control so that the gain of the RF amplifier and the loudness of the signal can be varied. One of the most common methods of controlling the gain of a TRF is to change the bias voltage of the RF amplifier stage by placing a variable resistor in the cathode circuit.

You will recall, from previous discussion, that the RF amplifier stage usually employs a variable-mu pentode tube. Varying the bias of this variable-mu tube causes the amplification factor of the tube to vary, and therefore the gain of the stage to vary. If there are several RF amplifiers, the variable resistor may be connected in such a manner as to vary the bias of all of the RF amplifiers. The fixed resistor in the cathode circuit is placed there to provide the proper bias when the variable resistor is set for maximum gain at the zero resistance position.

A variation of the grid bias volume control employs a potentiometer, which also acts as a variable shunt across the primary of the antenna coil. When the moving arm of the potentiometer is moved to the left, the resistance across the primary of the antenna coil is reduced while the cathode resistance is increased. This results in a weaker signal on the grid and reduced voltage amplification. When the sliding arm is moved to the extreme right, the resistance across the primary is increased, while the cathode resistance is reduced. This produces a stronger signal on the grid and increased voltage amplification.

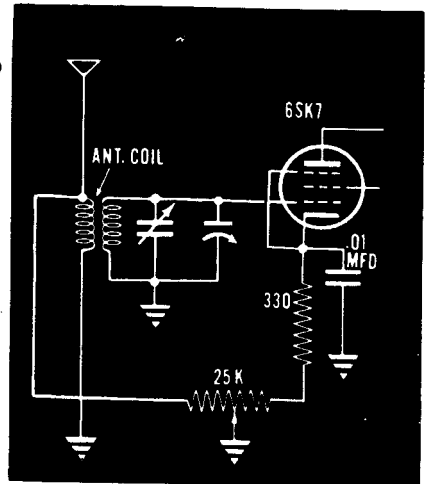

Analysis of the RF Amplifier

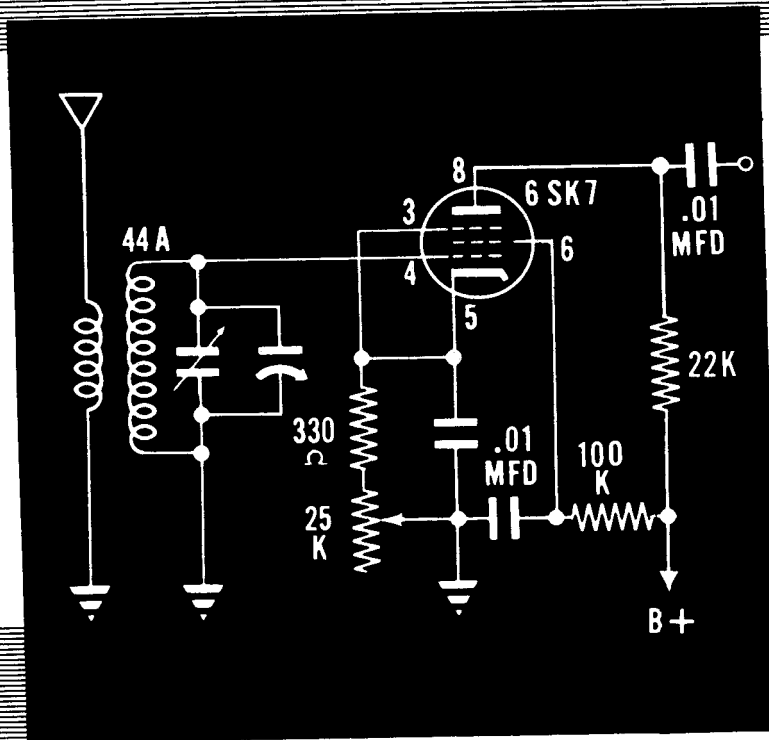

The RF Amplifier

Suppose you pause for a moment to examine the RF amplifier shown above and to review the purpose of each component. The antenna coil couples the antenna to the control grid of the RF amplifier. The variable capacitor enables the operator to tune the amplifier to the frequency of the desired signal, and thus provides selectivity. The 25K variable resistor acts as a volume control, while the 330-ohm resistor provides limiting cathode bias. The .01 mfd capacitor between the cathode and ground is the cathode bypass capacitor. The 100K resistor in the screen grid circuit is the screen grid voltage dropping resistor, which serves to keep the screen grid at a lower positive potential than the plate. The .01 mfd capacitor in the screen grid circuit is the screen grid bypass capacitor, which acts as a bypass for RF signals, and enables the screen to act as a shield between the plate and the control grid. The 22K resistor in the plate circuit is the plate load, while the .01 mfd capacitor in the plate circuit is used for the purpose of coupling the plate circuit to the grid of the next stage, and at the same time effectively blocking the passage of direct current.

TRF RECEIVERS—AUDIO AMPLIFIER STAGE

What the Audio Power Amplifier Does

Your next job with radio receivers will be to review an audio power amplifier. You need an audio power amplifier in your receiver because you will want to pick up stations and hear them in a loudspeaker. Loudspeakers have to push the air and make it move in order to produce sounds.

A loudspeaker converts electrical power into sound power. To supply the loudspeaker with sufficient power, an audio power amplifier is put in as the last stage of a receiver.

Like the RF amplifier, you will find an audio power amplifier in just about every receiver you will repair or operate. Here is a chance to add another building block to your know-how on receivers.

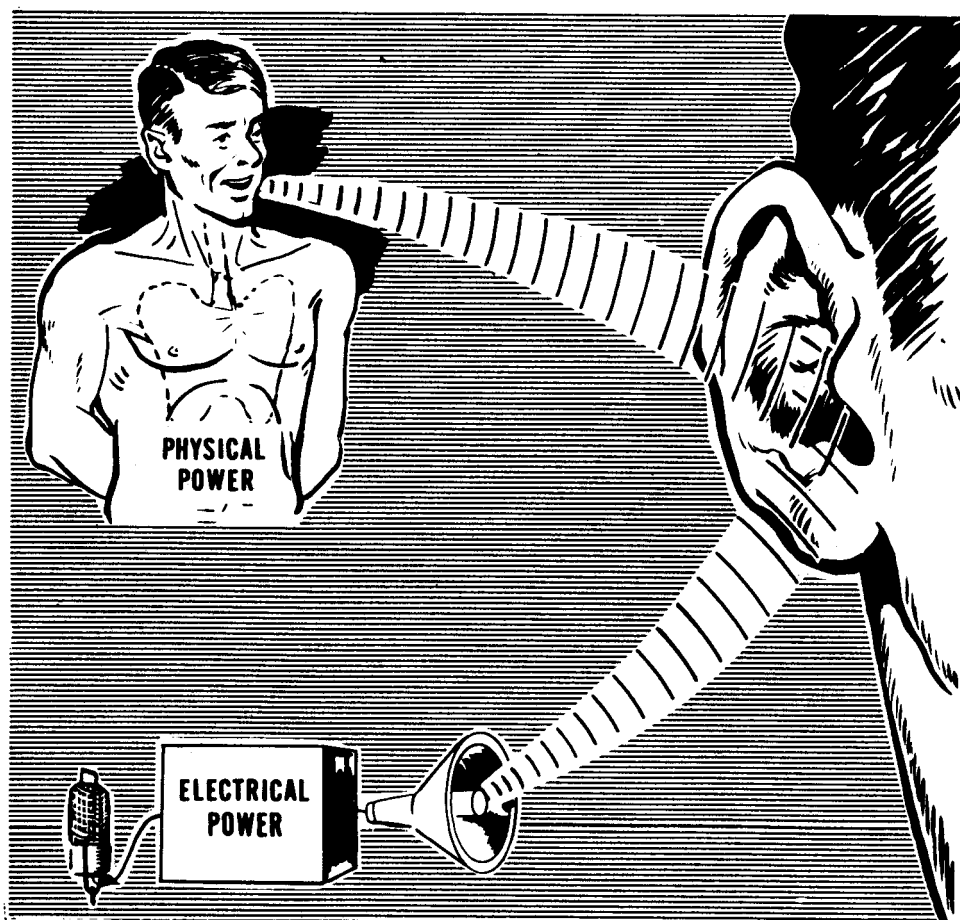

TRF RECEIVERS—AUDIO AMPLIFIER STAGE

AF Amplifier Tone Control Circuits

The tone or pitch of a complex sound depends upon whether there is a greater proportion of high frequency or low frequency waves in the sound. In other words, a high-pitched sound has more high frequency sound waves, while a low-pitched sound consists mainly of low frequency sound waves.

The sound emitted by a radio receiver may differ considerably from the original sound applied to the transmitter. The main reason for this is that audio amplifiers do not amplify all the frequencies by the same amount, and loudspeakers do not respond equally well to all frequencies.

Other causes of distortion are static and tube noises which generally are high audio frequencies of a random nature. To prevent the annoying interference from static and noise, and to provide a deeper bass effect which most radio listeners seem to prefer, many radio receivers employ some means of tone control. This is accomplished by eliminating some of the higher frequencies—shunting them to ground or bypassing them around the output transformer.

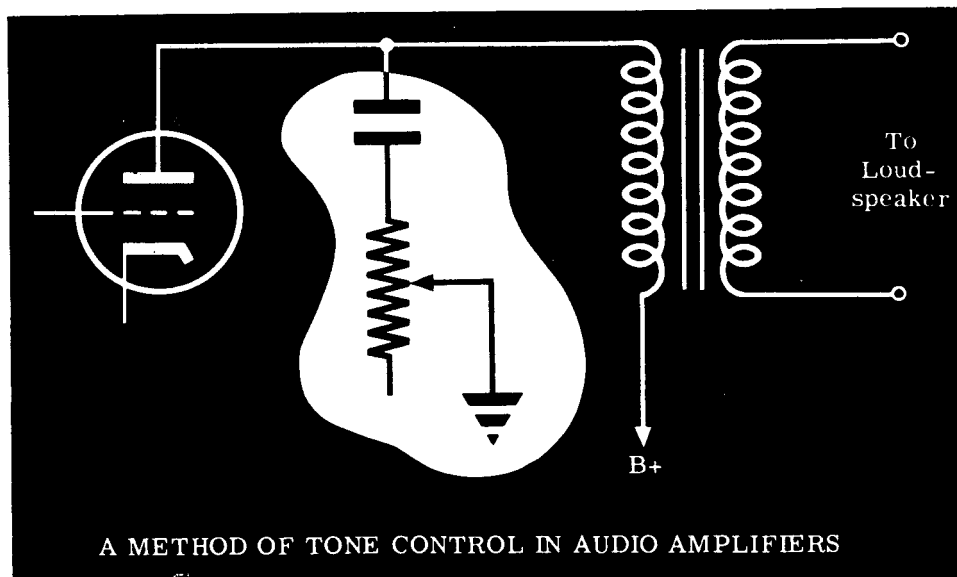

You will note that the capacitor in the plate circuit offers a relatively easy path for the higher audio frequencies, while the lower audio frequencies encounter a path of less opposition by traveling through the primary coil of the transformer. In this way, the amount of high frequency sound reaching the loudspeaker is considerably reduced. The variable resistor acts as a means of tone control. If the resistance is made very high, the path through the capacitor to ground becomes one which offers high opposition to the passage of high frequency as well as low frequency signals. As a result less high frequency current flows through the bypass capacitor and there is a rise in the pitch of the sound coming out of the loudspeaker.

TRF RECEIVERS—AUDIO AMPLIFIER STAGE

AF Amplifier Volume Control

You have previously been given a description of one method of controlling the volume of a receiver. This method involved varying the bias of the RF amplifier stage. There is another commonly used method of volume control involving the detector and AF amplifier stages.

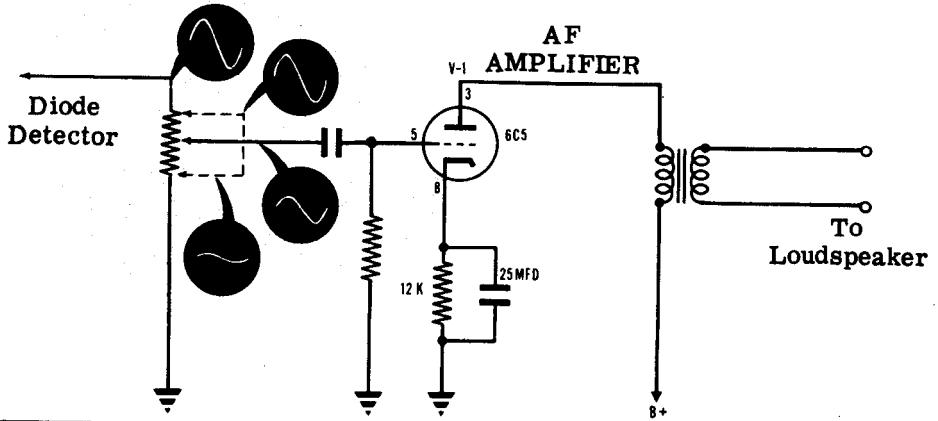

DETECTOR-OUTPUT VOLUME CONTROL

Notice that the detector is coupled to the AF amplifier by means of resistance-capacity coupling circuit. The volume control is basically a voltage divider, the moving arm tapping off the desired amount of signal voltage which is then applied, through the coupling capacitor, to the grid of the AF amplifier. This type of volume control is frequently employed in superhet receivers.

Some receivers employ a dual type of volume control. This control regulates the gain in the first and second RF amplifier stages by varying the cathode bias, and also controls the gain by varying the amplitude of the input signal applied to the first AF amplifier.

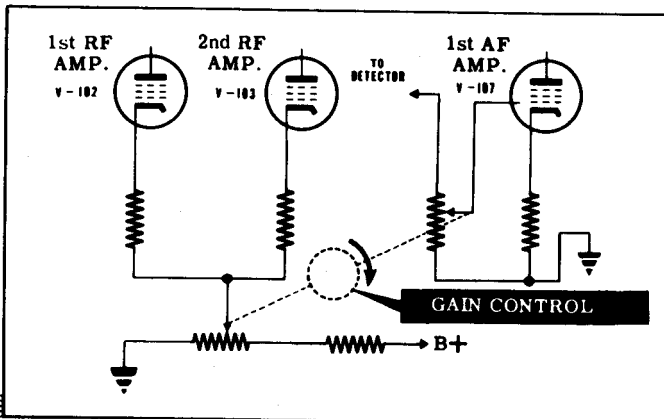

GRID CONTROL OF RECEIVER

TRF RECEIVERS—AUDIO AMPLIFIER STAGE

Analysis of the AF Amplifier Circuit

Now stop for a few minutes and analyze the functions of the various component parts of the AF power amplifier circuit shown here. Notice that no provision is made in this AF amplifier stage for volume or tone control.

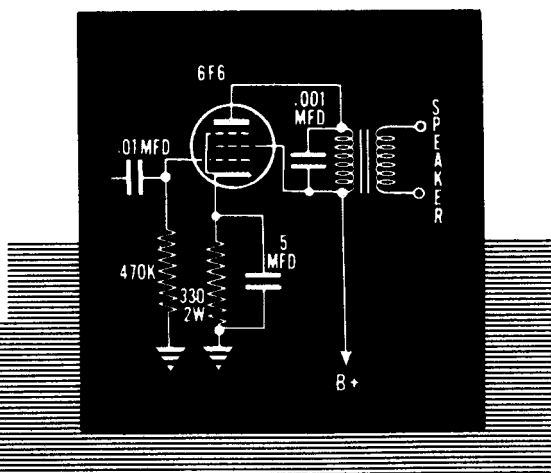

The 0.01-mfd coupling capacitor and 470K grid resistor found in the control grid circuit couple the control grid of the amplifier to the preceding detector stage. The capacitor also reduces the possibility that any DC voltages from the detector stage might be impressed upon the control grid of the amplifier.

The 330-ohm resistor acts as a cathode bias resistor, while the 5-mfd capacitor bypasses the varying component of the plate current around the cathode resistor, thus preventing the production of a varying bias and the accompanying reduction in amplification.

The primary of the output transformer acts as the plate load and couples the amplifier to the loudspeaker. The .001-mfd capacitor across the primary bypasses high frequency audio signals around the primary and this reduces the amount of high frequency sounds and noises emitted by the loudspeaker.

Components	Functions
0.01-mfd capacitor and 470K resistor	Couples AF amplifier to preceding detector stage
330-ohm resistor	Provides cathode bias
5-mfd capacitor	Bypasses signal around cathode bias resistor
0.001-mfd capacitor	Prevents high frequency audio signals from entering loudspeaker
Output transformer	Acts as plate load and couples amplifier to loudspeaker

TRF RECEIVERS—AUDIO AMPLIFIER STAGE

Comparison of RF and AF Amplifiers

Since most radio receivers you will encounter contain both RF and AF amplifiers, you must possess a clear understanding of the differences between them and the advantages and disadvantages of each. The following comparisons should serve to clarify your conceptions of RF and AF amplifiers.

RF Amplifiers

1. Designed to amplify frequencies above 20,000 cycles.
2. Usually have tuned circuits, thereby adding selectivity.
3. Usually coupled to other stages by RF air-core transformers.
4. Precede the detector stage.
5. Designed for voltage amplification.
6. If triodes are used they lack stability and must be neutralized.
7. Generally employ variable- μ pentodes.

AF Amplifiers

1. Designed to amplify frequencies between 15 cycles and 20,000 cycles.
2. Untuned and do not add to selectivity of set.
3. Coupled to other stages by AF iron-core transformers, or by resistance-capacity coupling.
4. Follow the detector stage.
5. Designed for power amplification.
6. Very stable and not likely to oscillate—if triodes are used, no neutralization is required.
7. Generally employ triodes, beam-power tetrodes, and power pentodes.

TYPICAL RF AMPLIFIER STAGE

TYPICAL AF AMPLIFIER STAGE

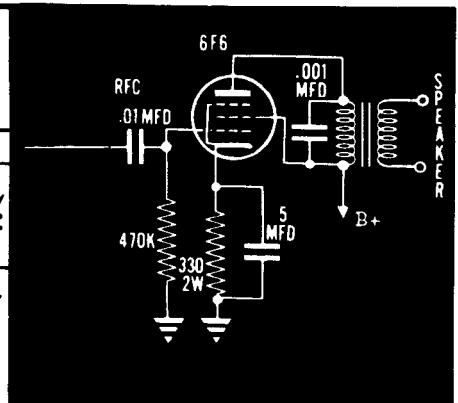
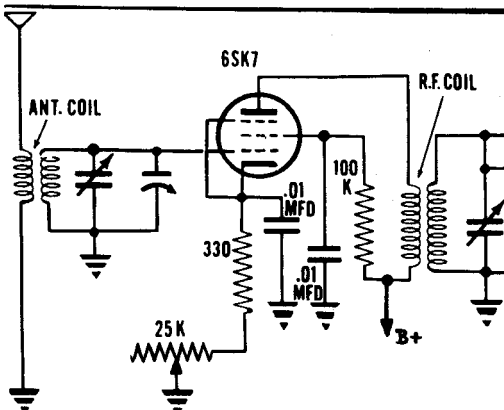

TRF RECEIVERS—REGENERATIVE DETECTOR

What the Detector Does

The detector is the key circuit of the radio receiver. The primary purpose of this circuit is to change the RF signal into a signal which can be reproduced as sound by the headphones or loudspeaker. Without the detector, radio reception is not possible. The simplest radio receiver contains a detector, an antenna and a pair of headphones. All of the other stages which are found in more complex receivers, such as the TRF and superhet, have been placed there for the primary purpose of enabling the detector to do a better job. In order to understand the purpose of the detector, it is necessary to review briefly the theory of radio-telephone transmission.

In the section on radio transmitters, it was made clear that radio-telephone transmission requires the generation of a radio-frequency carrier wave. Intelligence is impressed upon this wave by varying the amplitude of the carrier wave in direct proportion to the amplitude of the sound impulses. This combination of audio-frequency waves superimposed upon a carrier wave is known as an amplitude-modulated signal. It is this combination of waves that is picked up by the antenna of the radio receiver.

When transmitted signals reach a receiver, the desired signal is selected by the tuned circuit of the detector, or of the RF amplifier stage if the receiver employs such a stage. The selected signal is then rectified by a crystal or vacuum tube rectifier in the detector. The RF component is filtered out of the rectified signal, and the audio component is changed into sound waves by earphones or a loudspeaker. The process of detection includes the rectification and filtering steps, and these two steps are performed by the detector.

THE PROCESS OF... DETECTION

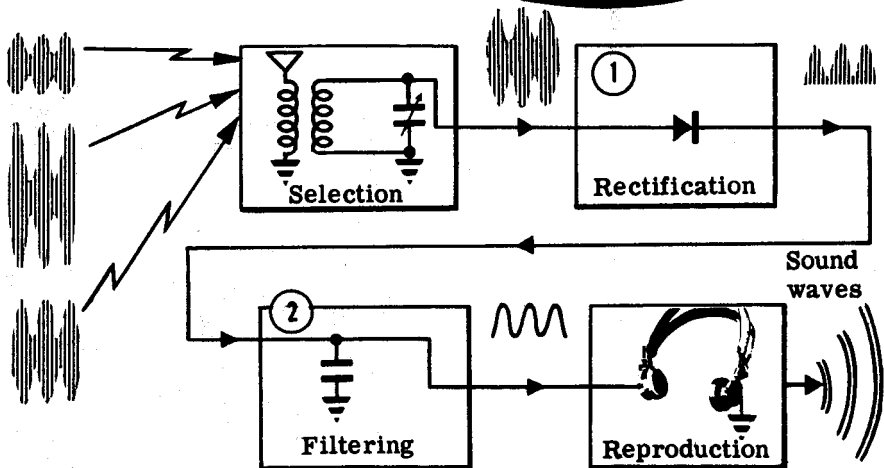

The Crystal Detector

The simplest of all detectors is the crystal type. If you understand how it works, you should have very little trouble understanding the operation of the somewhat more complicated vacuum-tube detectors.

A CRYSTAL DETECTOR

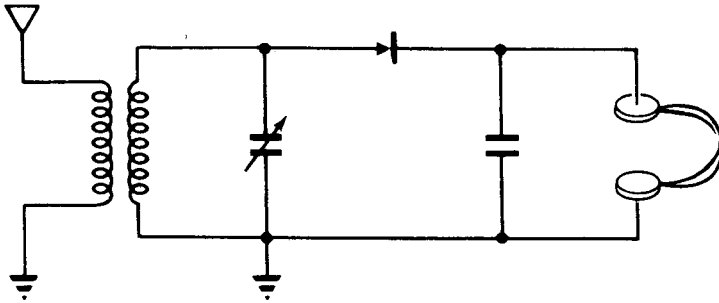

The modulated radio waves which are radiated from the transmitter's antenna induce corresponding signal voltages and currents in the antenna-ground system of the radio receiver. These signals are then transferred to the detector circuit by means of a radio-frequency transformer. If there are several transmitters in operation nearby, there will be several signals found at this point. Unless these signals are separated from each other, they will all be detected and the listener will hear a confused mixture of sounds. In other words, the selectivity will be extremely poor. It is the function of the coil and variable capacitor to separate these signals and thus provide selectivity. The coil and capacitor are called the "tuned circuits."

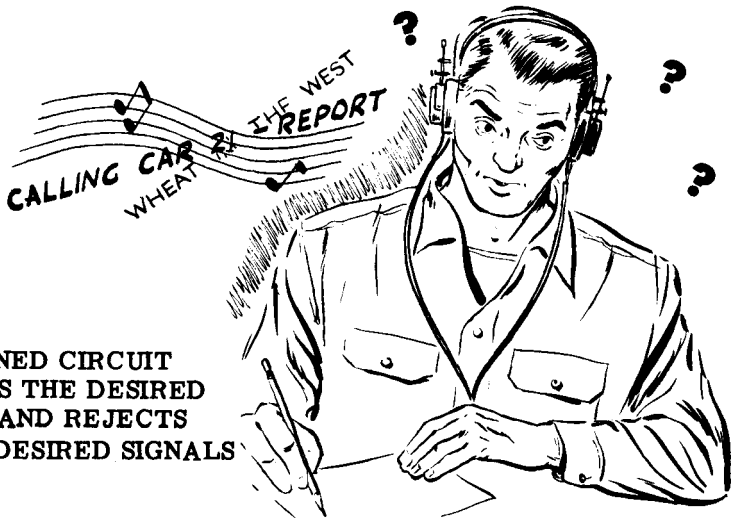

**THE TUNED CIRCUIT
SELECTS THE DESIRED
SIGNAL AND REJECTS
THE UNDESIRE SIGNALS**

TRF RECEIVERS—REGENERATIVE DETECTOR

How the Crystal Detector Works

You will probably recall from a previous discussion dealing with the selectivity of RF amplifiers that signals of differing frequencies can be separated from each other by taking advantage of the selective properties of a resonant or tuned circuit. A circuit of this type generally contains a fixed coil and a variable capacitor. It is capable of selecting or accepting radio signals of one particular frequency and rejecting those of all other frequencies. In addition, the tuned circuit produces a step-up or gain in signal voltage at resonance.

The tuned circuit can be adjusted to resonate or respond to a higher or lower frequency signal by varying the size of the capacitor. You will also encounter tuned circuits in which the capacity is kept constant and the tuning is accomplished by varying the inductance of the coil. Nevertheless, most resonant circuits are tuned by varying the capacitor.

Returning to our crystal detector, it is apparent that the variable capacitor and the secondary of the RF transformer form a tuned circuit. It is this circuit that gives the detector some degree of selectivity or ability to discriminate between desired and undesired signals.

The selected signal is rectified by the detector and the result is a pulsating DC signal containing two components, one of which is radio frequency and the other, audio frequency. The AF component passes through the headphones and produces sound waves similar to those originally used to modulate the radio wave. The RF component is bypassed around the headphones by the filtering action of a small capacitor placed across the headphones.

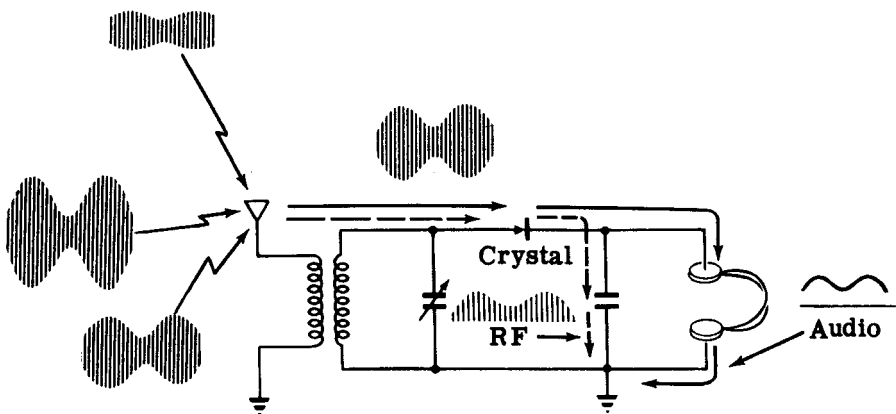

HOW A CRYSTAL
DETECTOR WORKS

—————> Audio Frequencies
- - - - -> Radio Frequencies

TRF RECEIVERS—REGENERATIVE DETECTOR

Characteristics of the Crystal Detector

The crystal detector possesses the advantages of simplicity and economy. In addition, it requires no batteries or other local sources of power. There are no filaments to burn out or produce hum and noise. In applications requiring the detection of ultra-high frequency signals, the crystal possesses certain decided advantages over the vacuum-tube detector.

Although transistors, which are crystals capable of amplifying signals, have been developed recently, the ordinary crystal detector provides no amplification. The crystal detector is therefore characterized by low sensitivity.

The galena crystal has still another disadvantage. Certain portions of the face of the crystal have better rectifying properties than the remaining portions. This makes it necessary to explore the face of the crystal with a wire probe called a "cat's whisker" until a sensitive rectifying point is found. The wire can easily be dislodged from this sensitive point and consequently, reception is likely to be erratic. In addition, dirt, grease or air-borne dust may spoil the sensitive spot and make it necessary to search for another spot.

These difficulties have been overcome in the more modern germanium and silicon crystal rectifiers. These consist of small sealed cartridges containing contact wires that cannot be dislodged. They have an extremely long life and resist shock and vibration better than most conventional vacuum tubes.

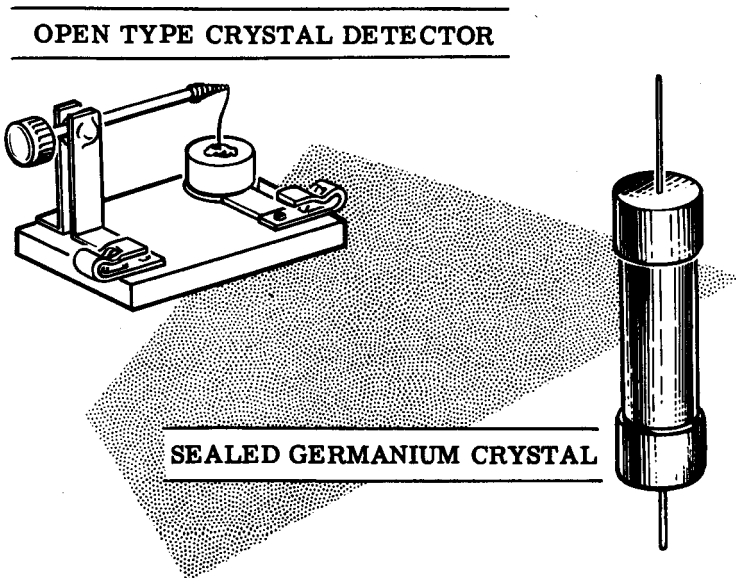

TRF RECEIVERS—REGENERATIVE DETECTOR

The Diode Detector

The fundamental circuit of the diode detector closely resembles that of the crystal detector. Consequently, the operating principles and characteristics of these two detectors resemble each other closely.

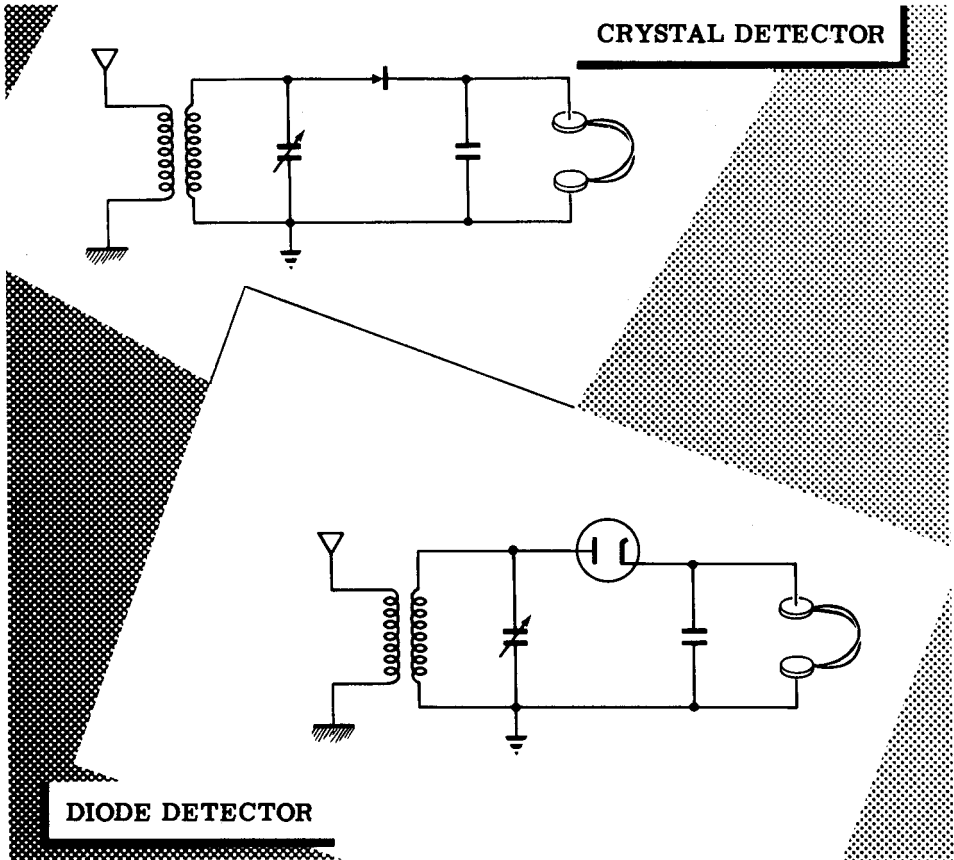

You will observe that the only difference between the diode and crystal detectors is the replacement of the galena crystal by a diode tube. The processes of selection, rectification and filtering are carried on in the manner previously described under crystal detectors. Diode detectors are characterized by faithful reproduction and low sensitivity. When the detector is operating, plate current flows through the tuned circuit during the positive half of each signal cycle. This plate current flow produces what is known as a "loading effect." This in turn has the effect of reducing both the voltage gain and selectivity of the tuned circuit.

Because of these factors and because it is capable of handling large signal voltages without distortion, the diode detector is generally preceded by one or more tuned RF amplifiers which provide increased sensitivity and selectivity. The detector is usually followed by one or more stages of AF amplification to provide sufficient power to operate a loudspeaker.

TRF RECEIVERS—REGENERATIVE DETECTOR

The Grid-Leak Detector

You have seen that since the diode detector cannot amplify, it is generally used in a receiver containing several stages of amplification. If you desire a receiver which uses fewer tubes, it is necessary to use a more sensitive detector—one which amplifies as well as detects. In order to amplify, the detector must of necessity use a tube containing a control grid, such as a triode, tetrode or pentode.

The triode detector which is easiest to understand is the grid-leak detector. This is because the grid-leak detector is basically a diode detector followed by a stage of audio-frequency amplification.

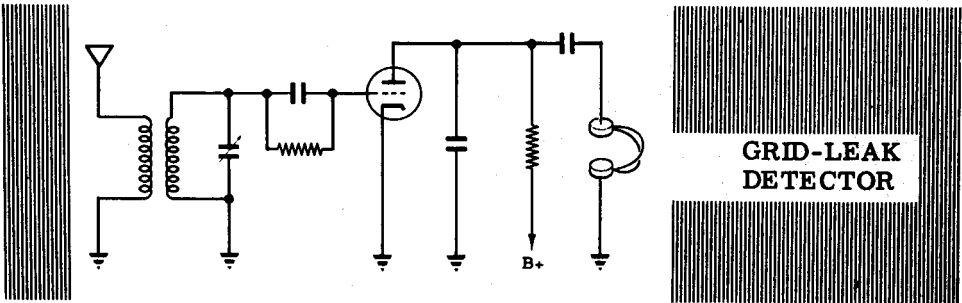

Suppose you examine the grid and cathode circuits of this detector and temporarily forget about the plate circuit. The result will be the circuit shown in the following diagram:

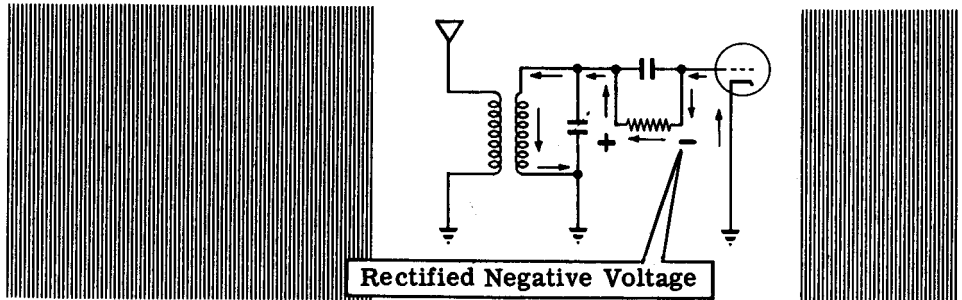

Note that this is basically the circuit of the diode detector. The control grid of the triode is taking the place of the diode plate, the grid-leak resistor has replaced the diode load or earphones, and the grid capacitor is acting as an RF filter capacitor across the load.

When a modulated signal voltage is applied to this circuit, the grid will attract electrons from the cathode during the positive half-cycles. The flow of current through the grid-leak resistor to ground produces a voltage drop across the grid-leak resistor. Because of the fact that current can flow in only one direction in the grid circuit, this voltage remains constant in polarity. The grid is thus biased, or kept at a negative voltage with respect to the cathode. The amount of bias will vary in accordance with the amplitude or modulation of the signal. In other words, the bias will vary at an audio-frequency rate.

The Grid-Leak Detector (continued)

Suppose you consider the complete grid-leak detector circuit.

Schematic of a grid-leak detector

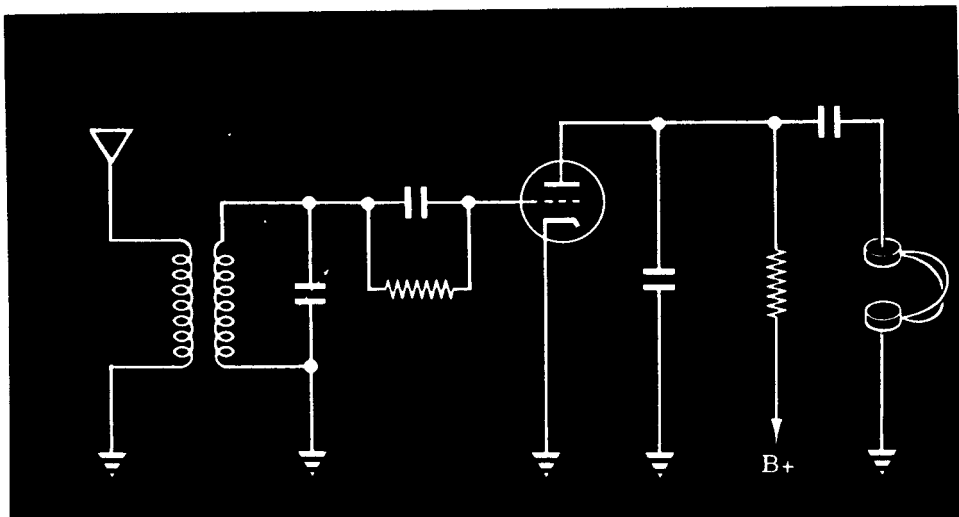

You will recall that the plate current of a triode is dependent upon the grid voltage. Consequently the audio frequency variations in bias should produce a corresponding pulsating plate current. Any radio frequency component of the plate current is filtered out by capacitors and RF chokes placed in the plate circuit. As a result, the voltage developed across the plate load is an amplified reproduction of the audio frequency voltage developed across the grid-leak resistor.

When there is no incoming signal, no bias is produced. Consequently, the plate current is high when no signal is being detected. When a signal is received, the grid becomes biased negatively and the average amount of plate current decreases.

The amount of grid bias developed is equal numerically to the amount of grid current multiplied by the amount of resistance of the grid-leak. Therefore the larger the grid-leak resistor, the greater will be the amplitude of the signal developed. For that reason, extremely sensitive grid-leak detectors usually use grid-leak resistors whose values are between one and five megohms.

However, if a strong signal comes in, it is quite possible that enough bias may be created to cut off the flow of plate current during part of the cycle, thus producing distortion. In order to reduce this distortion, grid-leak power detectors are used. They are designed for use with more powerful signals and generally employ smaller resistors in the grid circuit.

The Regenerative Detector

The regenerative detector, which is extremely sensitive, is a modification of the grid-leak detector. It utilizes the principle of regeneration, or strengthening the signal by feeding the amplified signal produced in the plate circuit back to the grid. From your work with oscillators you should have acquired an understanding of the nature and importance of regeneration. A regenerative detector is nothing more than a combination of an oscillator and a grid-leak detector. If you understand the operating principles of each of those circuits, the regenerative detector should give you very little trouble.

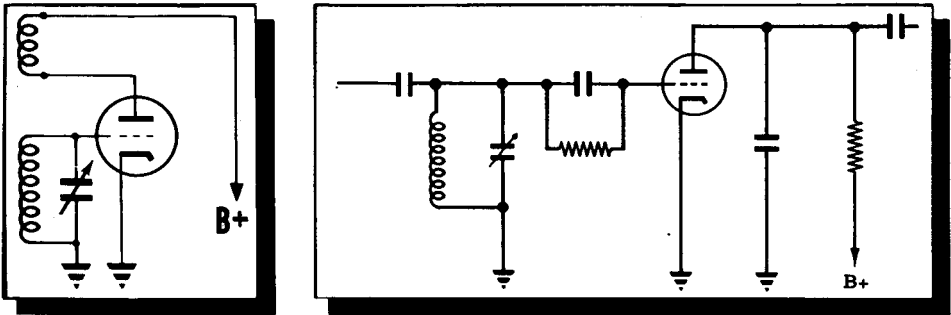

An Oscillator + A Grid-Leak Detector

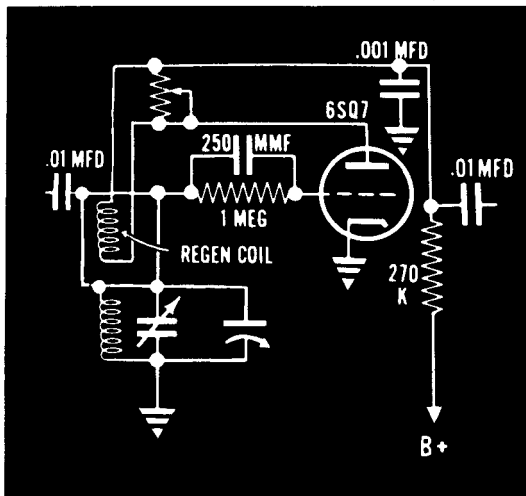

= A Regenerative Detector

TRF RECEIVERS—REGENERATIVE DETECTOR

How the Regenerative Detector Works

The regenerative detector circuit is similar to that of the grid-leak detector except for the coil in the plate circuit and the variable resistor across the coil. This circuit is shown on the previous sheet.

The plate coil, sometimes called the "tickler coil," feeds back voltage to the grid circuit in phase with the incoming signal voltage, thus increasing the voltage gain and sensitivity of the detector. The variable resistor is placed across the coil to control the amount of feedback or regeneration.

Why control the amount of feedback? The answer becomes obvious if you consider that when feedback becomes excessive, a circuit will begin to oscillate and produce squeals and howls. On the other hand, if there isn't enough feedback, this detector is hardly any more sensitive than the grid-leak detector. Control of feedback enables us to avoid the two extremes and strike a happy medium.

There are many ways of controlling the amount of feedback. One method which has been used involves varying the physical position of the tickler coil with respect to the grid coil. If the coupling between the two coils is reduced by moving the tickler coil away from the grid coil, or rotating it so that its axis is at an angle to the axis of the grid coil, the amount of feedback will be reduced. When this method is used to control feedback, a potentiometer is not connected across the tickler coil.

ARRANGEMENT TO VARY COUPLING BETWEEN TICKLER AND GRID COIL

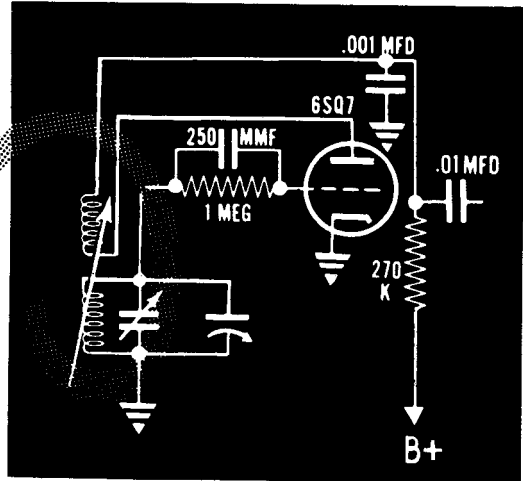
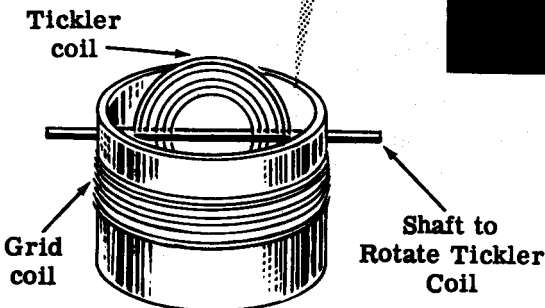

TRF RECEIVERS—REGENERATIVE DETECTOR

How the Regenerative Detector Works (continued)

Another method of regeneration control makes use of a variable capacitor which is placed between one side of the tickler coil and ground. Decreasing the size of the capacitor, reduces the amount of RF energy available in the plate circuit for regeneration.

REGENERATION CONTROL EMPLOYING A VARIABLE CAPACITOR

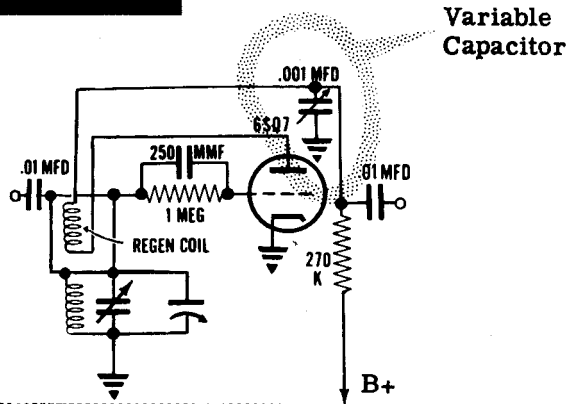

REGENERATION CONTROL EMPLOYING A VARIABLE RESISTOR

Variable Resistor

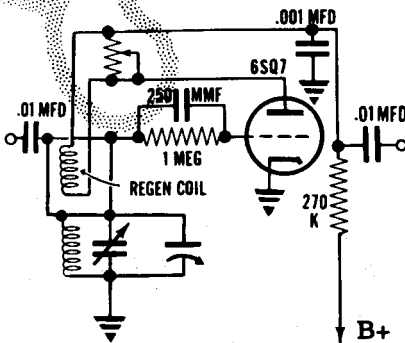

In the detector shown above, regeneration is controlled by a variable resistor placed across the tickler coil.

When the movable arm of the potentiometer is in the upper position, the tickler coil is effectively shorted out and there is no regeneration. The detector is now, for all practical purposes, a grid-leak detector. When the potentiometer arm is moved to the other extreme position, most of the RF current will flow through the tickler coil rather than through the potentiometer. As a result, the circuit will probably begin to oscillate.

TRF RECEIVERS—REGENERATIVE DETECTOR

How the Regenerative Detector Works (continued)

No matter what method is used to control regeneration, the control is usually advanced as far as possible without producing oscillations. In actual practice this is accomplished by tuning in a station, just as with any other type of detector. Then the regeneration control is turned up to the point at which whistles, howls and clicks are heard. This indicates that the detector is oscillating. The regeneration control is then turned back to the point where these interfering sounds just disappear. The regenerative detector is properly adjusted for maximum selectivity and sensitivity. This process of adjusting the regeneration control must be repeated each time a new signal is tuned in.

The regenerative detector is the most sensitive detector capable of receiving amplitude-modulated signals. The familiar walkie-talkie, used so successfully during the last war, employed a modified regenerative detector circuit.

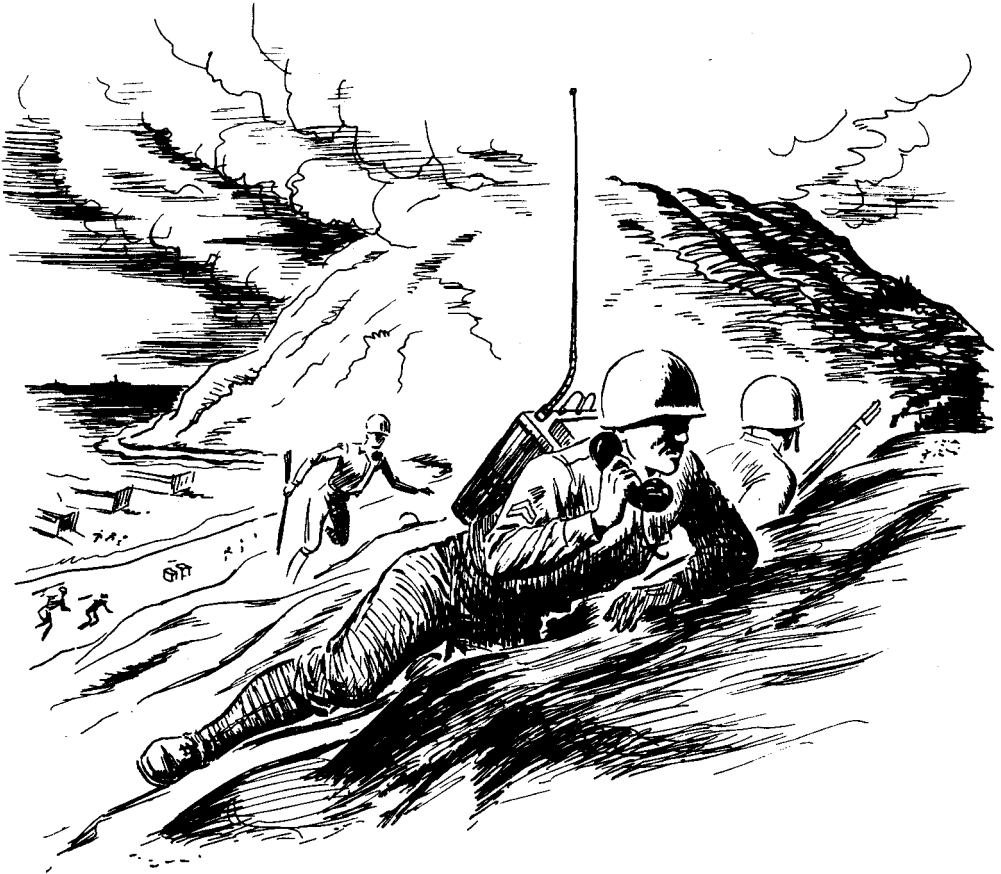

TRF RECEIVERS—REGENERATIVE DETECTOR

The Regenerative Detector as a CW Receiver

You may recall from your study of transmitters that there are several methods of impressing intelligence upon a carrier wave. One of these methods is known as "amplitude modulation." The crystal, diode and grid-leak detectors we have considered up to this point are designed for use with amplitude-modulated (AM) signals. Another method of conveying intelligence involves the interruption of a carrier wave in accordance with a code such as the Morse Code. These signals are called "interrupted continuous wave" or "CW signals." Since there is no modulation in this type of signal, it cannot be detected by crystal, diode or grid-leak detector circuits. In order to hear the signal, it is necessary to use a detector which employs the heterodyne principle. The heterodyne principle involves mixing the CW signal with a signal obtained from an oscillator. The result of this mixing is an AM signal which is interrupted in the same manner as the original CW signal. This AM signal can then be detected and the familiar "dit-dah" sound of code will be heard in the earphones.

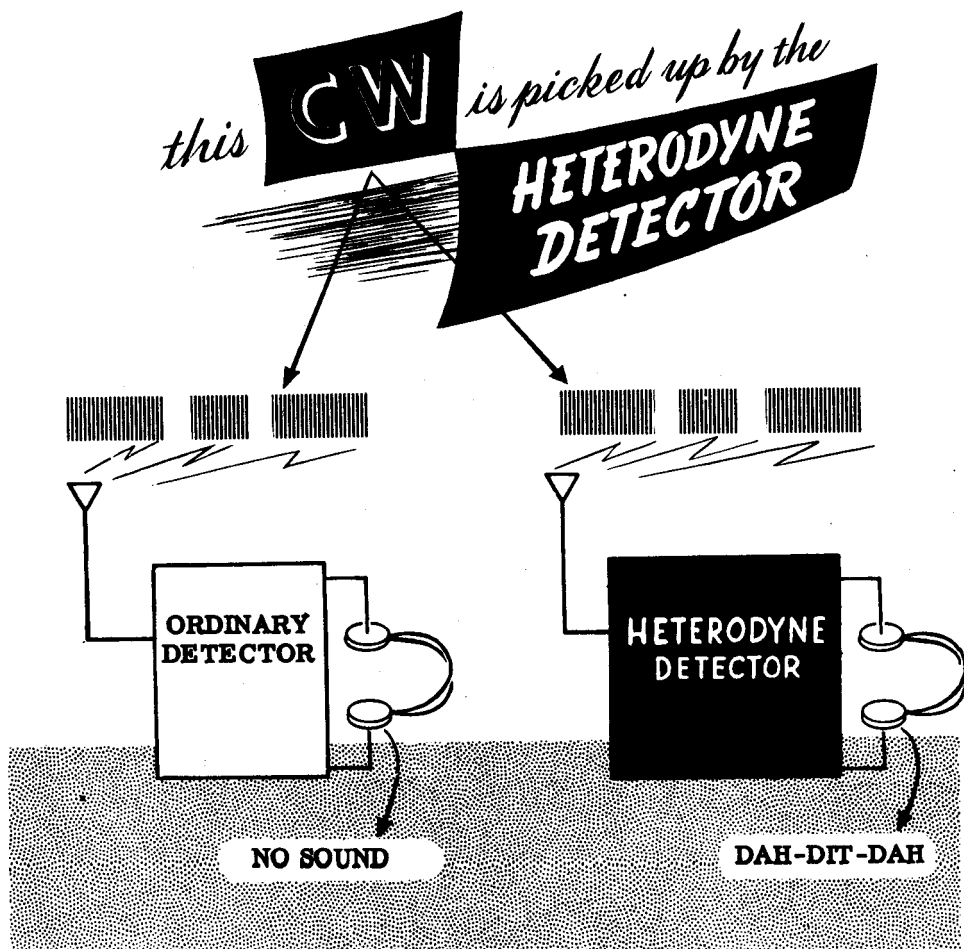

TRF RECEIVERS—REGENERATIVE DETECTOR

The Regenerative Detector as a CW Receiver (continued)

You may have observed that when two adjacent piano keys are struck at the same time, a distinct throbbing sound can be heard. This throbbing sound, known as a beat, has a frequency equal to the difference of the frequencies of the two notes struck. If the two notes struck have frequencies of 264 and 297 cycles respectively, the beat frequency will be equal to the difference between them, or 33 cycles.

Similarly, when two alternating voltages of slightly different frequencies are combined in a detector, the resultant wave circuit produced in the output will have a frequency which is equal to the difference between the frequencies of the two original voltages. This is the basis of the heterodyne principle.

For example, if two inaudible RF waves whose frequencies are 600 kc and 601 kc, respectively, are applied to a detector tube, the smaller wave (A) will add and subtract from the larger wave (B) to make the amplitude of the larger wave (B) vary in the manner shown. The rate of variation of the amplitude of wave B is the difference between the frequencies of the two waves—in this case 1 kc. Observe that wave B, because of the introduction of wave A, has been transformed into an amplitude-modulated wave. The audio modulation can be heard by detection of this AM signal.

The Heterodyne Principle

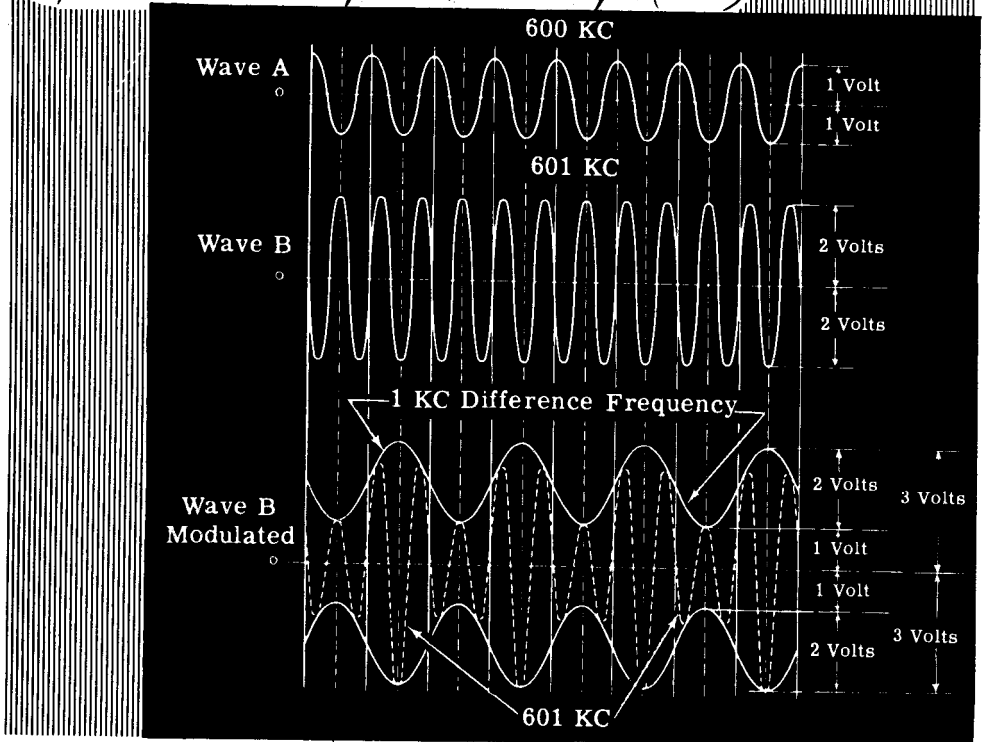

The Oscillating Detector

Some receivers designed for reception of CW signals employ a separate local oscillator known as a "beat-frequency oscillator" or "BFO." If the output of this oscillator is heterodyned against a continuous radio wave which is interrupted in accordance with the Morse Code, the audio beat note that is produced will be interrupted in a similar manner. In this way, the heterodyne principle makes possible the detection of CW signals. The heterodyne principle will also be applied in a later lesson dealing with the superheterodyne receiver.

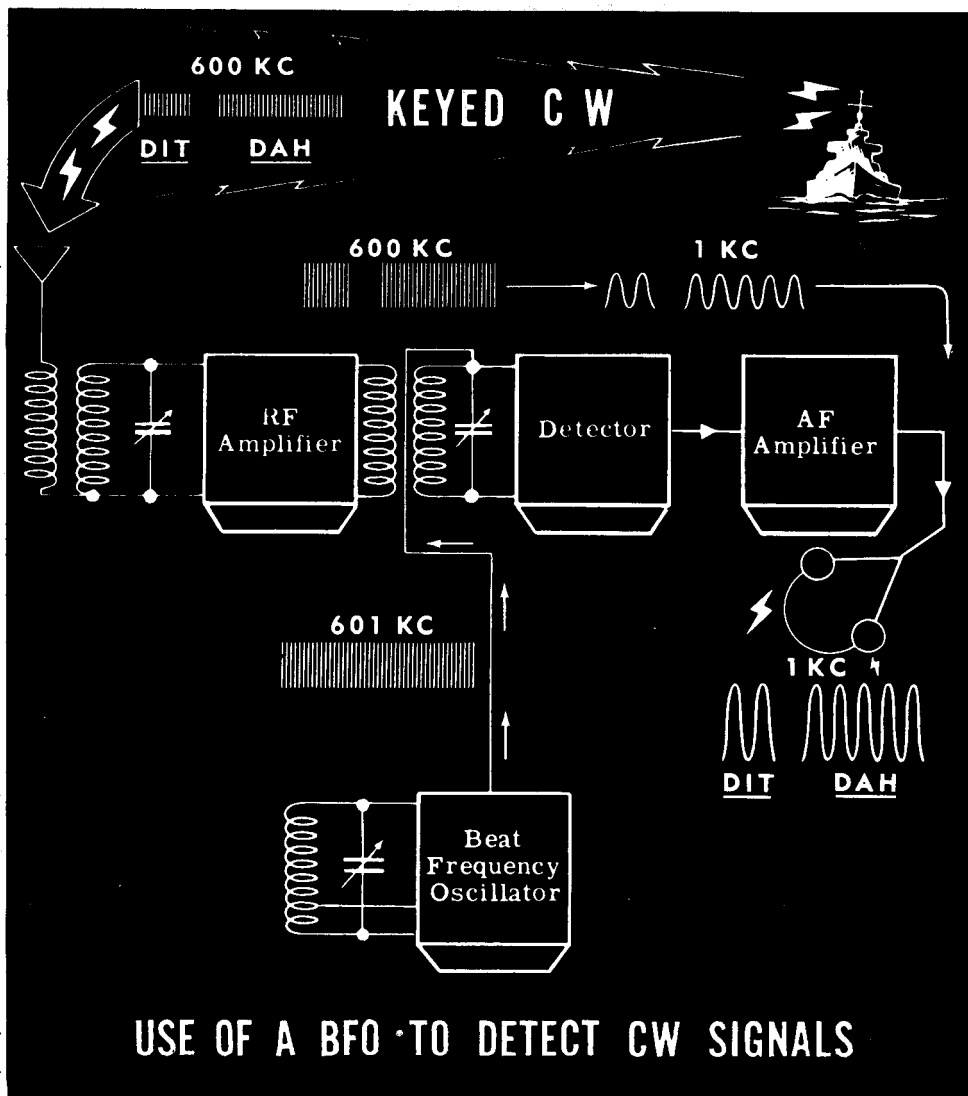

TRF RECEIVERS—REGENERATIVE DETECTOR

Analysis of the Regenerative Detector Circuit

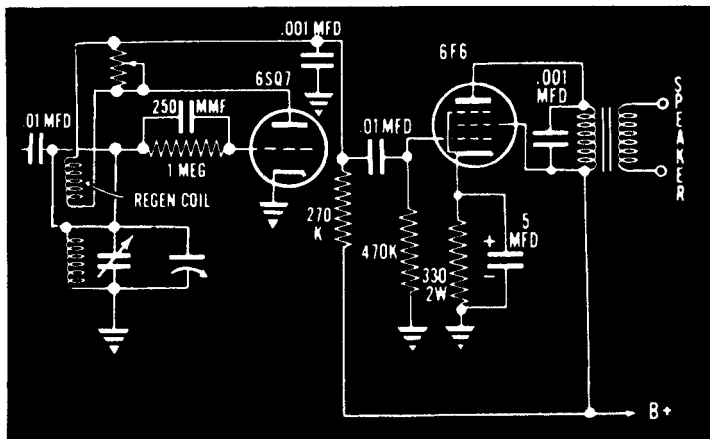

You know how the RF and AF amplifiers work. Suppose you review the functions of the various component parts used in the regenerative detector.

The .01-mfd capacitor found in the grid circuit is used to couple the preceding RF amplifier stage to the detector. The grid coil and variable capacitor provide tuning and selectivity. The 1-megohm resistor provides grid-leak bias while the 250-mmf capacitor acts as an RF bypass capacitor around the grid-leak resistor. The plate or tickler coil is inductively coupled with the grid coil and thus provides feedback, while the potentiometer across the tickler coil controls the amount of feedback. The .001-mfd capacitor is an RF filter or bypass capacitor around the 270K plate load resistor, and the .01-mfd capacitor in the plate circuit is used to couple the detector to the following AF amplifier stage.

COMPONENTS

FUNCTIONS

COMPONENTS	FUNCTIONS
.01-mfd capacitors	Couple detector to preceding and following stages
Coil and variable capacitor	Provide selectivity
1 megohm resistor	Provides grid-leak bias
250-mmf capacitor	Bypasses RF around grid-leak resistor
Regeneration coil	Provides feedback
500K potentiometer	Controls feedback
.001-mfd capacitor	Filters RF component of signal
270K resistor	Acts as plate load of detector

TRF RECEIVERS—REGENERATIVE DETECTOR

Review of Detectors

You have become acquainted with the basic principles of operation of four important types of detectors. We will now review the basic circuits and operating characteristics of each type.

CIRCUITS

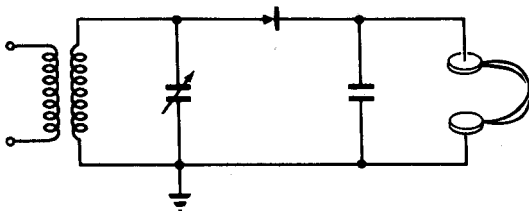

CRYSTAL DETECTOR

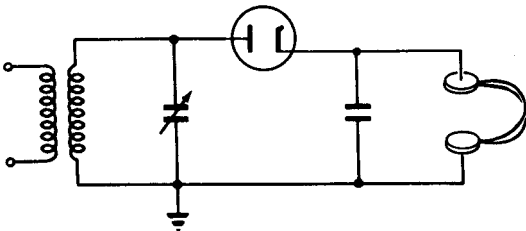

DIODE DETECTOR

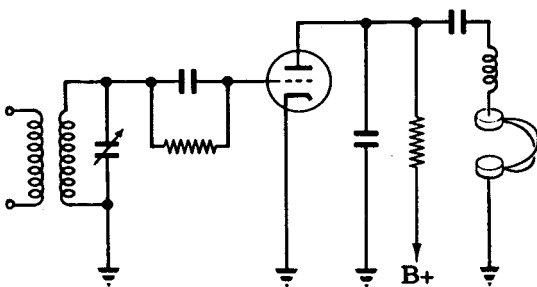

GRID-LEAK DETECTOR

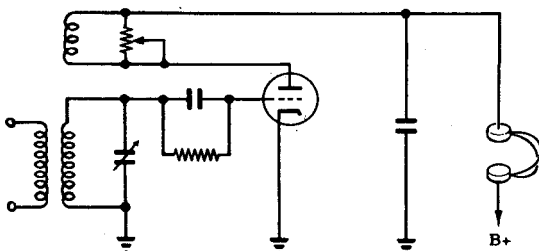

REGENERATIVE DETECTOR

CHARACTERISTICS

Low sensitivity
 Poor selectivity
 Good fidelity
 Low reliability
 Capable of handling strong signals
 Simple and economical to operate

Low sensitivity
 Poor selectivity
 Excellent fidelity
 High reliability
 Capable of handling strong signals
 Capable of supplying AVC voltages

High sensitivity
 Poor selectivity
 Low fidelity
 Moderate reliability
 Easily overloaded by strong signals
 Plate current decreases when a signal is received

Extremely high sensitivity
 Excellent selectivity
 Very poor fidelity
 Low reliability
 Easily overloaded by strong signals

TRF RECEIVERS—PLATE DETECTOR

How the Plate Detector Works

The plate detector employs a triode or pentode biased at, or near, cut-off. The bias is usually provided by means of a cathode bias resistor, or less frequently, by means of a bias battery placed between grid and cathode. The plate current will be at, or near, zero when no signal is received.

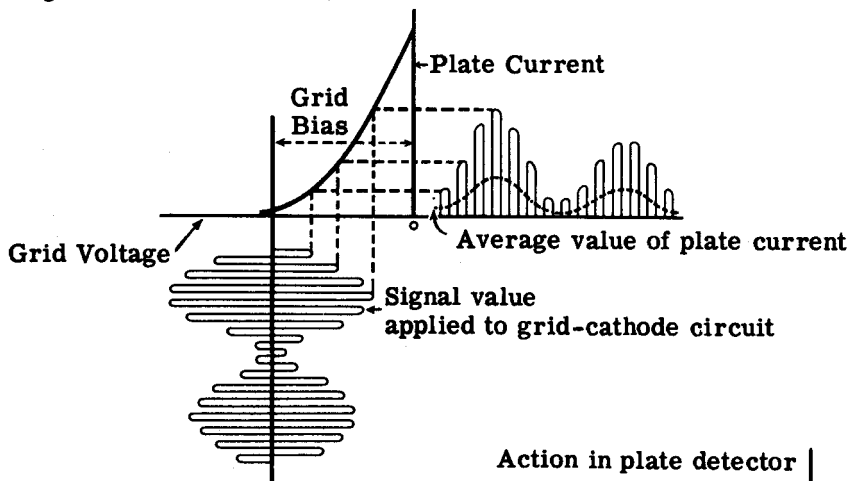

Action in plate detector

When a modulated RF signal is impressed on the grid, there will be a pulse of plate current during the positive half cycle and little or no plate current during the negative half cycle. The plate current will contain an amplified and rectified version of the input signal. The filtering of the RF component is accomplished by connecting a small capacitor between the plate and ground and an RF choke in series with the plate load. It is important that a small capacitor be used, since a capacitor that is too large will tend to filter out the higher audio frequencies as well as the radio frequencies.

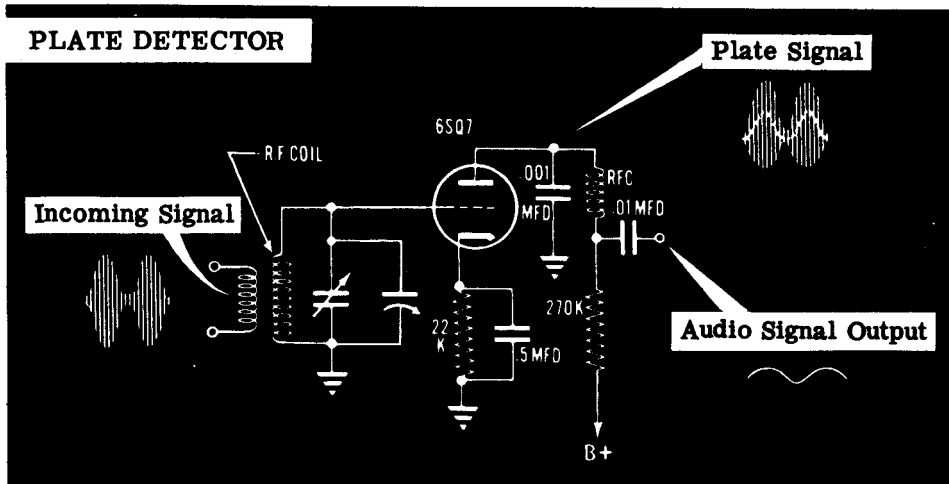

TRF RECEIVERS—PLATE DETECTOR

How the Plate Detector Works (continued)

In contrast with the action of the grid-leak detector, plate current in the plate detector is at a minimum with no incoming signal. Up to a certain point, the average plate current increases in direct proportion to the amplitude or strength of the signal impressed on the grid. Another important characteristic is that if care is taken not to drive the grid positive, the plate detector will consume no input power and there will be no loading effect upon the tuned circuit. Consequently the selectivity and fidelity of the plate detector surpasses that of the grid-leak detector.

On the other hand, among the disadvantages of the plate detector may be listed the fact that its sensitivity to weak signals is much less than that of the grid-leak detector. It also produces more distortion than the diode detector and it cannot directly provide a voltage to be used for automatic volume control.

The receiver shown below is a TRF receiver containing a plate detector. It also contains a beat-frequency oscillator to provide for reception of CW signals. The tuning capacitor of this oscillator is ganged with the RF amplifier stages in such a manner that a beat note of 1000 cycles will be heard when the receiver is tuned to a CW signal.

RECEIVER EMPLOYING A PLATE DETECTOR

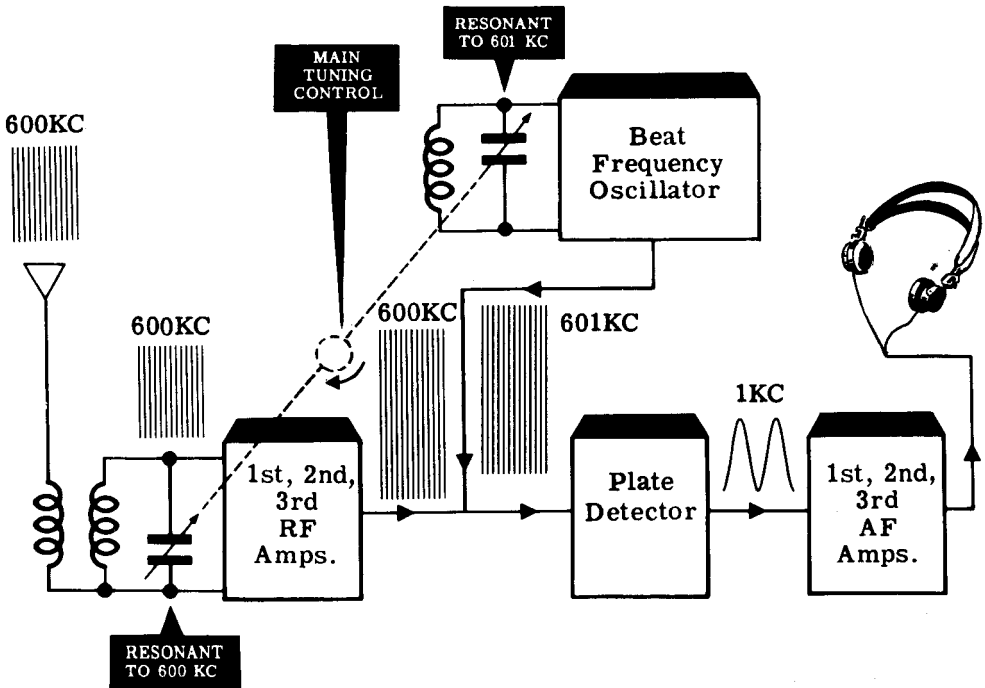

TRF RECEIVERS—PLATE DETECTOR

Analysis of the Plate Detector Circuit

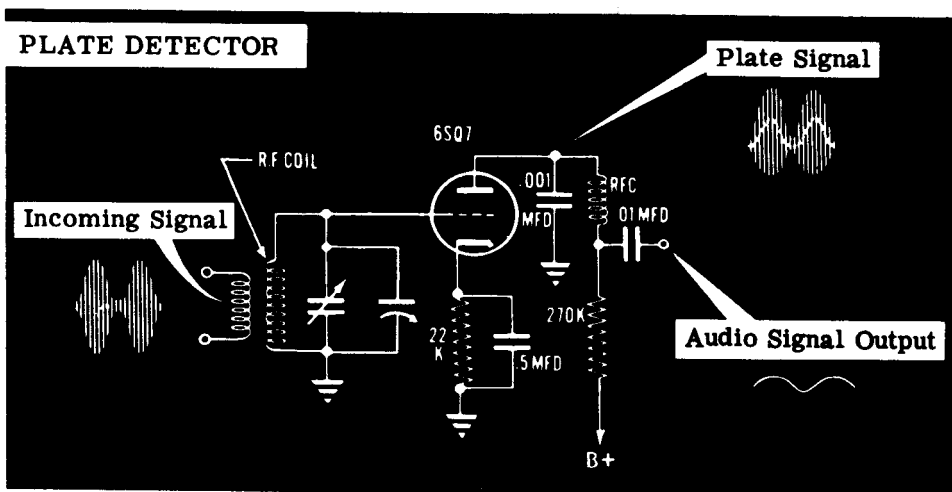

A brief analysis of the functions of the components used in the plate detector should help you to understand how this detector operates.

The coil and variable capacitor in the grid circuit form a tuned circuit and are obviously intended to provide selectivity. In addition, the grid coil of the detector is inductively linked with the plate coil of the preceding RF amplifier and thus couples these two stages. The 22K resistor in series with the cathode acts as the cathode bias resistor, biasing the tube almost to the point of cut-off, while the 0.5-mfd capacitor acts as a bypass capacitor around the cathode bias resistor. The RF choke and .001-mfd capacitor in the plate circuit serve to filter out the RF component of the signal while the 270K plate load resistor and the .01-mfd capacitor couple the detector to the following AF amplifier stage.

COMPONENTS	FUNCTIONS
RF coil and variable capacitor	Provide selectivity and couple detector to preceding RF amplifier stage
22K resistor	Provides cathode bias
0.5-mfd capacitor	Bypasses signal around cathode bias resistor
.001-mfd capacitor and RF choke	Filter RF component of signal
270K resistor	Acts as plate load of detector
.01-mfd capacitor	Couples detector to following AF amplifier stage

THE SUPERHETERODYNE RECEIVER

Introduction

The superheterodyne receiver is the most popular type of receiver in use today. Practically all commercial home radios are of this type. You will find either a superheterodyne circuit or a TRF circuit in practically every piece of electronic equipment that contains a receiver. This includes radar, sonar, communications gear—any device that picks up and receives a signal.

Knowing the TRF receiver gives you a good start toward learning the superheterodyne, because it uses all the basic components of a TRF—with three additional units. See the block diagram of a superheterodyne, showing the three additional units—mixer, local oscillator and intermediate frequency (IF) amplifier—which are in addition to the basic TRF circuit.

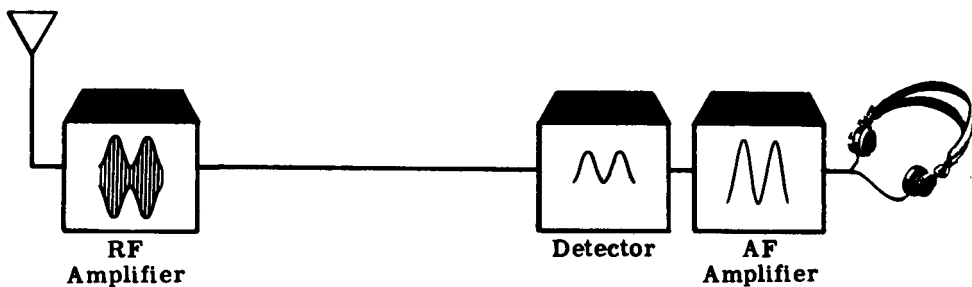

THE TRF RECEIVER

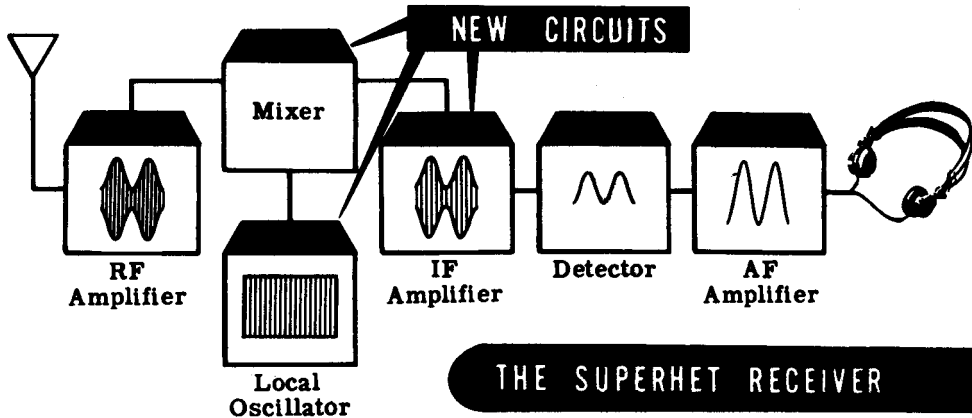

THE SUPERHET RECEIVER

THE SUPERHETERODYNE RECEIVER

The Superhet at High Frequencies

At high frequencies, the TRF receiver does not work as well as it does at lower radio frequencies. Above 20 mc, a conventional RF amplifier does not have the necessary sensitivity and selectivity.

The superheterodyne receiver avoids the difficulties encountered with the TRF at high frequencies by converting the selected signal frequency to a lower (intermediate) frequency (IF) which can be amplified more easily.

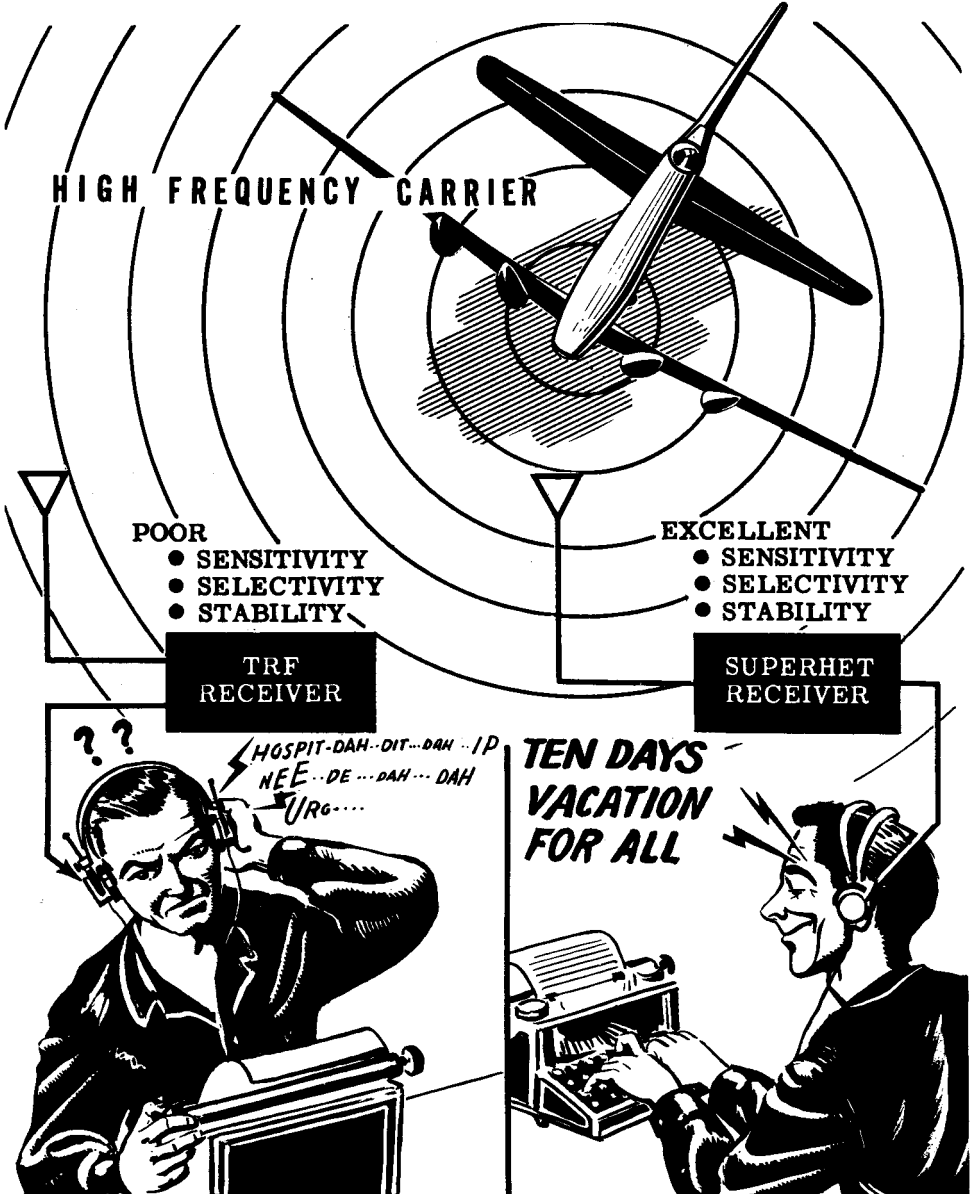

THE SUPERHETERODYNE RECEIVER

How the Superhet Works

If you know why the superheterodyne was developed, you will easily learn how it works. TRF receivers use RF amplifiers with variable tuned circuits to select and amplify the received signal. If the receiver has three RF stages before the detector, it will contain four tuned circuits. For the best selectivity and sensitivity, each of these four tuned circuits must be tuned to the same frequency. However, it is extremely difficult to make a multi-ganged tuning capacitor so that each section will tune its circuit to exactly the same frequency as the other sections. Therefore, the gain and selectivity of the TRF receiver is limited since more RF stages cannot be added conveniently.

The superheterodyne receiver overcomes this problem. It takes the incoming signal and converts the carrier frequency to another frequency. This new frequency is called the "intermediate frequency" (IF) and it does not vary regardless of the frequency to which the receiver is tuned. The IF signal is amplified in a series of high-gain amplifiers which are pre-tuned to this fixed IF frequency. Because it eliminates the many-ganged tuning capacitor, the superhet with its fixed frequency IF amplifiers can be used to give very large gains and very fine selectivity.

This is how the signal frequency is changed in the superhet. The incoming signal and the CW output of the local oscillator are fed into the mixer tube. The plate current is varied according to both of these signals which are of different frequencies. A beat (or difference) frequency appears in the resulting signal. This signal is then passed through the IF amplifiers which are tuned to this difference frequency. The IF signal has exactly the same modulation as the RF carrier. The only change has been the substitution of the IF frequency for the RF.

THE SUPERHET RECEIVERS MAKE USE OF . . .

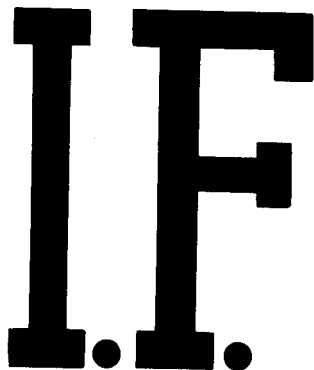

I.F.

AMPLIFIERS

THIS MEANS —

- 1. Greater Sensitivity*
- 2. Greater Selectivity*

THE SUPERHETERODYNE RECEIVER

Selectivity of the Superhet

This is what happens in a home superheterodyne radio set. When you tune it to a station of 880 kc, you are setting the tuned RF circuit to 880 kc and at the same time you are automatically tuning the local oscillator to 1336 kc. Two signals—one of 880 kc, the other of 1336 kc—are fed into the mixer stage. The output of the mixer stage contains a frequency of 456 kc which is the difference of its two inputs.

If at the same time the antenna picks up another station at a frequency of 1100 kc, the signal, if strong enough, can get by the first tuned circuit and would be mixed with the local oscillator output in the mixer stage. This undesired signal of 1100 kc would produce a beat-frequency of 1336-1100 or 236 kc.

The IF amplifier tuning, however, does not vary. It is always tuned to 456 kc. So you can see that only the beat signal produced by the desired station (880 kc) will be amplified by the IF amplifier. Since the undesired signal of 1100 kc produced a beat-frequency which is different from the IF frequency, its beat signal is not amplified. Thus, the superhet has selected the proper input signal on the basis of the frequency of the beat signal produced in the mixer stage.

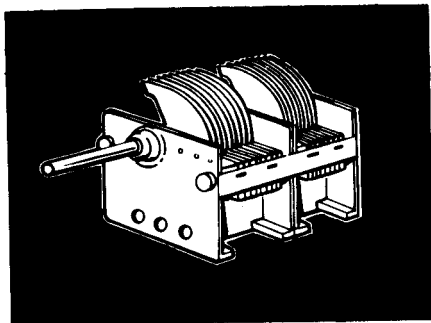

THE *ganged* *tuning capacitor*

KEEPS THE LOCAL OSCILLATOR

"TRACKING" THE TUNED RF

In order to hear the 1100-kc station, the receiver would have to be re-tuned. Turning the knob changes the frequency to which the RF amplifier is tuned and, at the same time, changes the local oscillator frequency. A two-section ganged tuning capacitor does the trick. Tuning the receiver does not affect the IF stages. When the RF tuned circuit is set at 1100 kc, the oscillator will be putting out a signal of 1556 kc; the IF remains at 456 kc.

Now it is the 1100-kc signal which produces the 456-kc beat-frequency. The beat produced by the 880-kc signal would be the difference between its frequency and the 1556-kc local oscillator frequency—676 kc—and this frequency will not be amplified by the IF stages.

In order for the superhet to work properly, the local oscillator must be adjusted so that it will always tune to a frequency which is a fixed number of kilocycles different from the desired RF frequency. Thus, as the receiver—that is, the RF tuned circuit—is tuned from 550 to 1600 kc, the local oscillator should tune from 1006 to 2056 kc. Then, any signal picked up at the frequency to which the receiver is tuned will produce an IF frequency of 456 kc (which is the standard IF frequency for commercial receivers).

THE SUPERHETERODYNE RECEIVER

RF Amplifier Stage

Many superhet receivers do not contain an RF amplifier stage. In such receivers the signal from the antenna is fed to the signal grid of the mixer or converter stage. However, you will encounter other receivers which contain stages of RF amplification preceding the mixer. You will therefore have a better understanding of the operation of superhet receivers if you know the reasons for including an RF amplifier stage.

The first function of the RF amplifier is to improve the signal-to-noise ratio. The mixer stage usually produces more tube noise than an RF stage of amplification. The signal, plus the tube noise, is amplified by the following IF amplifier stage. However, if the signal strength is increased by placing an RF amplifier stage before the mixer, less amplification is required in the IF amplifier stage. Since tube noises produced by the mixer are not amplified as much as they were when no RF stage was present, a greater signal-to-noise ratio is obtained.

The second function of the RF amplifier stage is related to radiation from the oscillator stage. It should not be forgotten that this oscillator is a low-powered transmitter. If there is no RF amplifier stage, the oscillator is connected through the mixer stage to the antenna. This antenna will radiate some energy from the oscillator. This radiated signal may cause interference with reception in nearby receivers and may also divulge the location of the receiver. This radiation may be reduced or prevented by using one or more stages of RF amplification, and by carefully shielding the oscillator stage.

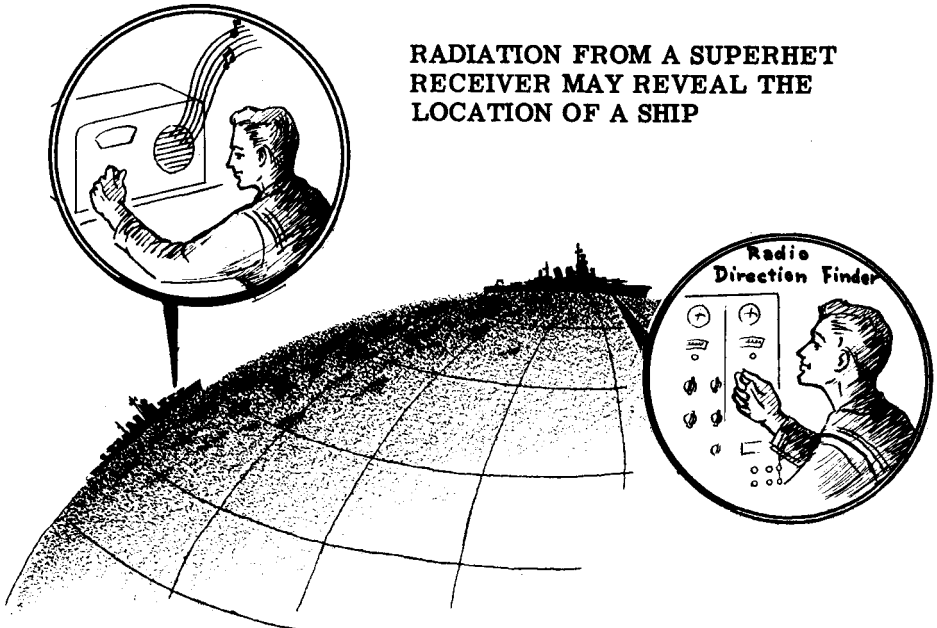

RADIATION FROM A SUPERHET RECEIVER MAY REVEAL THE LOCATION OF A SHIP

THE SUPERHETERODYNE RECEIVER

RF Amplifier Stage (continued)

The third function of the RF amplifier stage is concerned with selectivity. You will recall that in the TRF receiver the RF amplifier stages enabled the operator to select the desired signal from a group of signals whose frequencies were very close to each other. The RF amplifier in a superhet serves to prevent interference from a signal whose frequency may be several hundred kilocycles above that of the desired signal. This type of interference is called "image-frequency interference".

Let us assume that you have a superhet receiver without an RF amplifier stage and that the receiver is tuned to a station operating at a frequency of 600 kc. The oscillator in the receiver will be tuned to 1056 kc and the resulting IF signal will have a frequency of 1056 kc minus 600 kc or 456 kc. However, if there is a powerful station nearby, broadcasting at a frequency of 1512 kc, some of the signal from this station will enter the mixer stage where it will beat against the signal from the oscillator. The resulting signal will be 1512 kc minus 1056 kc or 456 kc—the same intermediate frequency as that produced by the desired station. The IF amplifier stage will amplify both signals equally well, since they are both at the correct frequency of 456 kc. This interference produces whistles and a confusing mixture of sounds coming out of the loudspeaker.

It should be noted that when the intermediate frequency is 456 kc, image interference is produced when there is a second station broadcasting at a frequency that is twice the intermediate frequency or 912 kc above that of the desired signal. Thus the image frequency of a station broadcasting on 600 kc is 912 kc higher, or 1512 kc. Image-frequency interference can be reduced by the use of an RF amplifier stage before the mixer. For this reason the RF amplifier is sometimes called a "preselector stage".

In any receiver in which images might present a problem, one tuned circuit is not enough to guarantee the elimination of this interference. There will be as many as two or three stages of RF amplification at the signal frequency before the signal is fed into the mixer. These stages are not as selective as those in a TRF, but are selective enough to discriminate between the desired signal and the image frequency. These stages, called "preselector" stages, do not present the alignment problems of the TRF since none of these stages need to be sharply tuned to the resonant frequency.

The preselector serves another purpose besides suppressing the image. It also isolates the antenna from the local oscillator so that there will be no possibility of the receiver radiating energy.

THE SUPERHETERODYNE RECEIVER

The Local Oscillator

In a superhet receiver circuit, the local oscillator is tuned by a variable capacitor ganged with the tuned RF circuit in the antenna input. The local oscillator is tuned to oscillate and put out a signal at a frequency that is above or below the RF frequency by a fixed difference for every position of the tuning dial—every received frequency. The local oscillator output is mixed with the RF carrier. The fixed frequency difference is the IF output of the mixer.

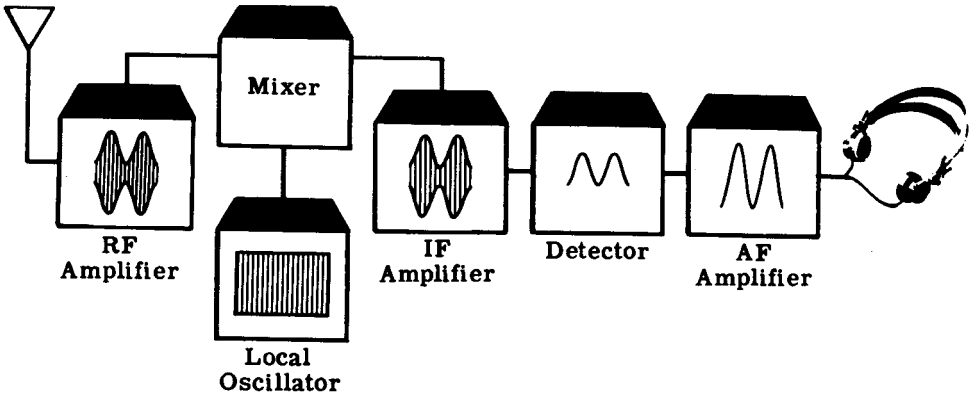

The process of mixing or beating two frequencies together to get a difference frequency is called "heterodyning." That is why the receiver was named superheterodyne.

The superhet you will discuss will have a tuned-grid type oscillator that operates at 456 kc above or below the RF frequency. The IF is 456 kc. The variable capacitor in the oscillator tank is ganged with the tuning capacitor in the antenna tuned circuit, as shown in the illustration of that section.

As the receiver is tuned to an incoming signal, the local oscillator is also varied to keep it at a frequency of 456 kc higher or lower than the signal to which the antenna circuit is tuned. The table below gives examples of typical operating frequencies.

TYPICAL OPERATING FREQUENCIES FOR THE SUPERHET

FREQUENCY OF RF CARRIER	FREQUENCY OF LOCAL OSCILLATOR	IF DIFFERENCE FREQUENCY
550 kc	1006 or 94 kc	456 kc
710	1166 or 254	456
880	1336 or 424	456
1440	1896 or 984	456

THE SUPERHETERODYNE RECEIVER

The Local Oscillator (continued)

There are several types of oscillators that may be employed as local oscillators. However, the types most frequently used are modifications of the Armstrong tickler-coil and the Hartley oscillators. An ideal local oscillator should possess the following characteristics:

1. The frequency of its output should be stable and free from drift at all settings.
2. It should be capable of delivering considerable voltage to the mixer. This voltage should be approximately ten times greater than that of the RF signal.
3. The strength of the output should be constant over the entire frequency range.
4. The oscillator should have minimum interaction with other tuned circuits. If the oscillator interacts with other tuned circuits, there will be a change in oscillator frequency each time the other circuits are tuned.
5. The oscillator should radiate a minimum of energy into space.

The oscillators found in receivers used for broadcast band reception are usually designed to produce a signal whose frequency is 456 kc higher than the frequency of the incoming radio wave. The tuning capacitor of the oscillator is ganged with the capacitor of the RF tuned circuit so as to maintain a constant difference in frequency as the receiver is tuned across the band. This is known as "tracking." Perfect tracking is the condition when the oscillator tuned circuit is resonant exactly 456 kc higher than the RF tuned circuits for all settings of the tuning dial. The process of adjusting the tuned circuits, to maintain this constant difference at both the high and low ends of the tuning bands, is known as "aligning." The process of adjusting a receiver to obtain good tracking will be discussed more completely in the section dealing with the alignment and adjustment of superhet receivers.

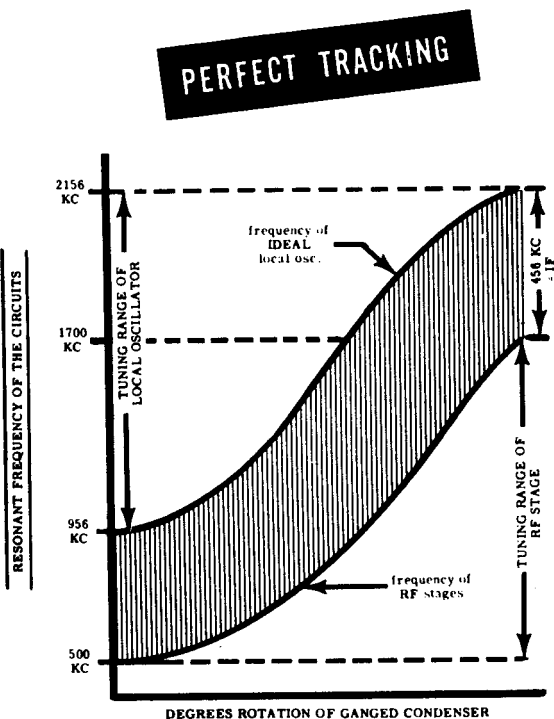

THE SUPERHETERODYNE RECEIVER

The Local Oscillator (continued)

There are two ways of designing the oscillator tank circuit so that it will produce a signal 456 kc higher than that of the RF circuit. One method employs a special kind of ganged capacitor. The plates of the oscillator section of this capacitor are made smaller than the plates of the RF section. Since the capacity of the oscillator section is less than that of the RF section, the oscillator section will resonate at a higher frequency. In addition, the plates of the oscillator section are shaped so as to produce correct tracking as the plates are meshed or unmeshed.

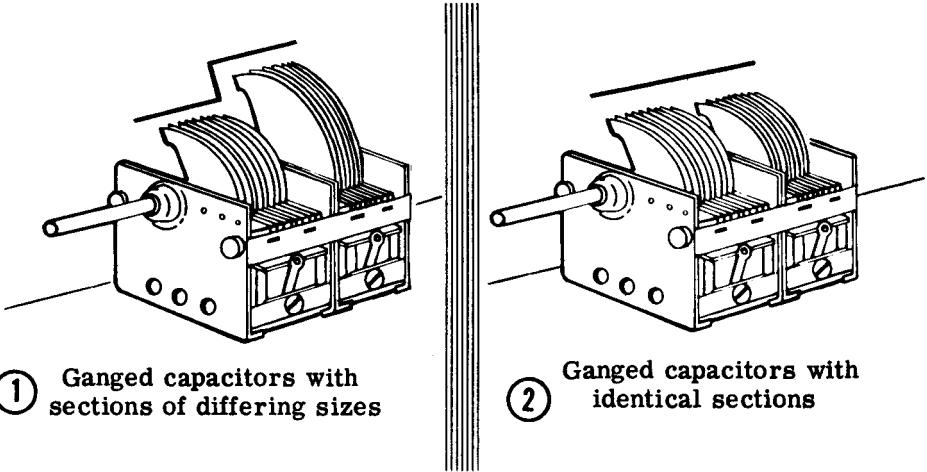

When both sections of the capacitor are identical, the total capacity of the oscillator tank circuit is reduced by placing an adjustable mica capacitor, called a "padder" capacitor, in series with the oscillator tuning capacitor. As a result of this reduction in capacity, the oscillator circuit resonates at a higher frequency. The capacity of the padder is usually between 500 and 1000 mmf. In the process of alignment, the padder capacitor is adjusted for perfect tracking at the low frequency end of the band.

In order to align the superhet receiver at the high frequency end of the band, trimmers are placed in parallel with each section of the tuning capacitor, just as they are in TRF receivers. These trimmers are adjustable mica capacitors whose capacity varies between 2 and 20 mmf.

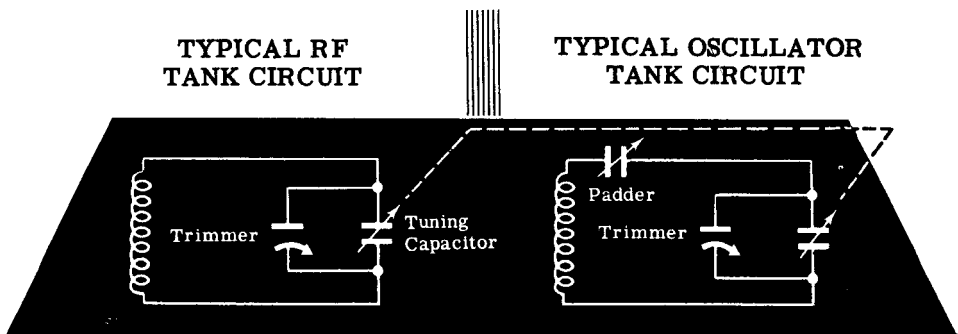

THE SUPERHETERODYNE RECEIVER

How the Mixer Stage Works

The mixer works on the following principle: If two different frequencies are mixed or combined in a tube, the output will contain four different frequencies which are:

1. The modulated RF signal from RF amplifier or antenna
2. The unmodulated local oscillator RF output
3. The sum of 1 and 2
4. The difference of 1 and 2

The difference frequency is the desired signal. This signal resulting from the mixing of a modulated carrier with the unmodulated output from the oscillator will have exactly the same modulation shape as the original carrier wave. Tuned circuits are used to amplify the desired signal and discriminate against the others.

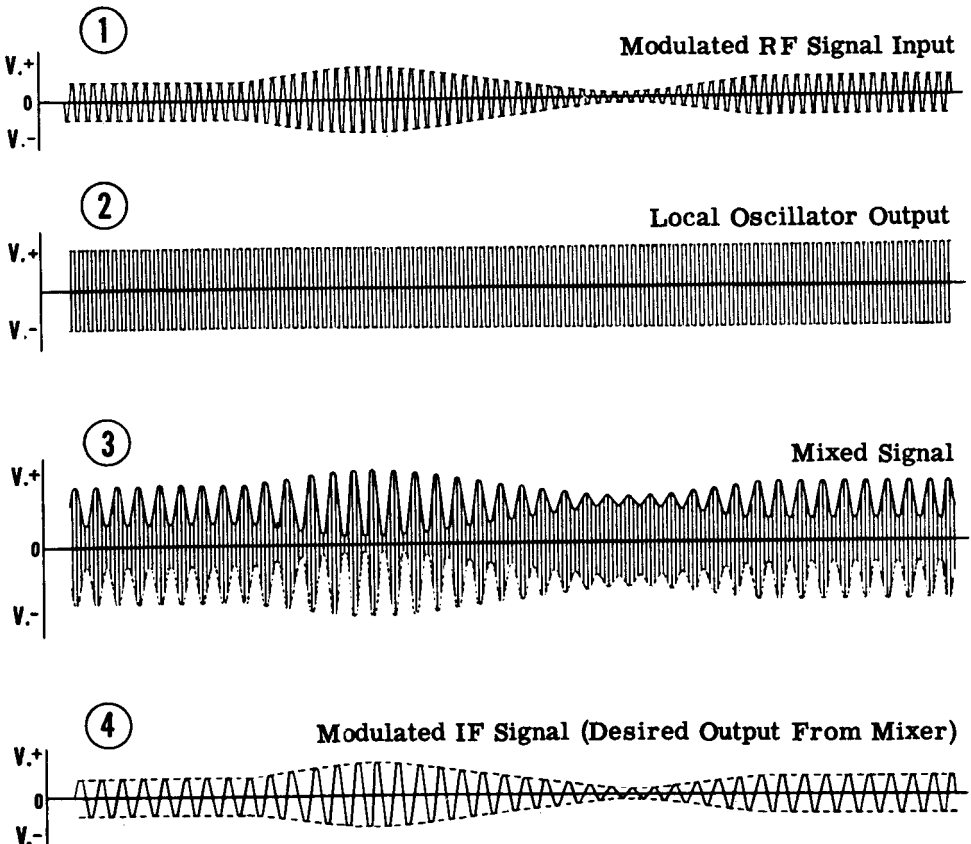

THE SUPERHETERODYNE RECEIVER

How the Mixer Stage Works (continued)

From among the several frequencies present in the plate circuit of the mixer tube—the original RF signal, the oscillator signal, a signal whose frequency is the sum of the first two signals, and another signal whose frequency is equal to their difference—only the latter or IF signal must be passed on to the next stage. This is accomplished by using the primary of a tuned IF transformer as the plate load. The primary and secondary coils are tuned to the intermediate frequency which generally is 456 kc. In this manner, maximum response is obtained for the IF signal. This IF signal is passed on to the following IF amplifier stage, while the other signals are rejected by the selective action of the tuned IF transformer.

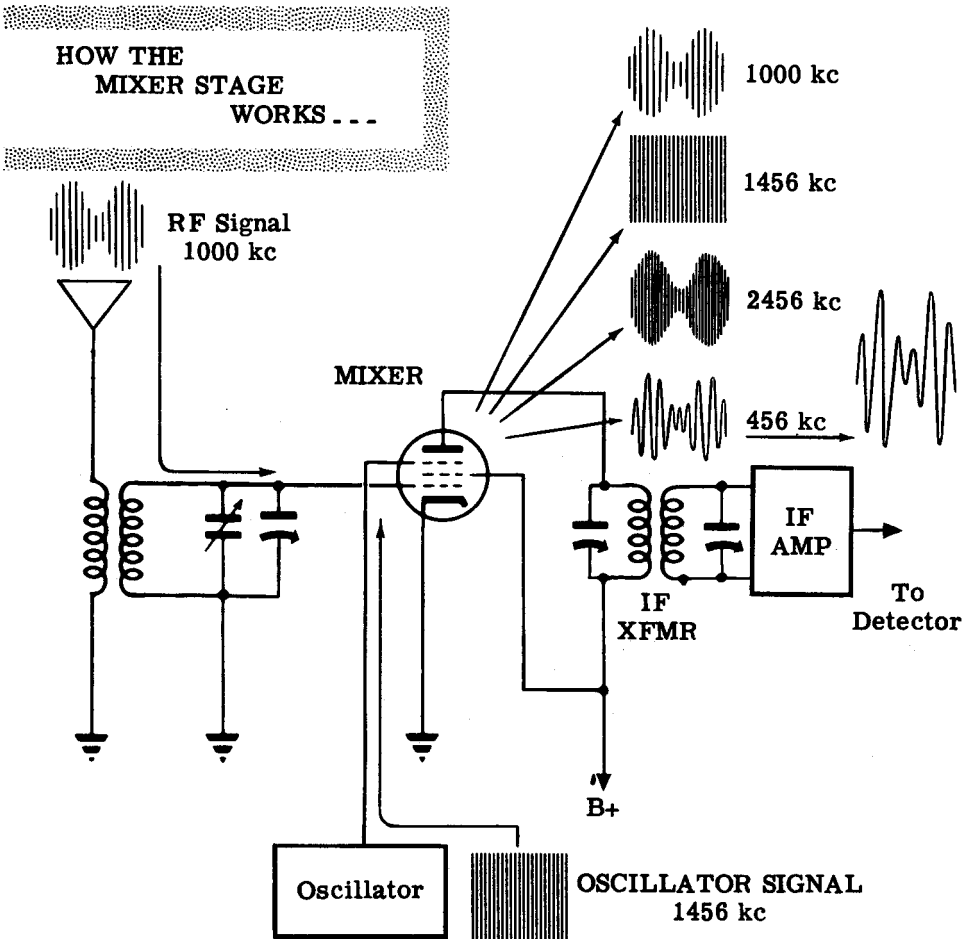

THE SUPERHETERODYNE RECEIVER

How the Mixer Stage Works (continued)

From the preceding discussion it may be seen that the principal function of the mixer or first detector stage is to act as a frequency converter. The input to this stage is a modulated RF signal whose frequency is relatively high. This signal is converted to a lower frequency modulated IF signal by means of the heterodyning action taking place in the mixer. The IF signal now possesses all the intelligence originally contained in the RF signal.

There are a large number of combinations of tubes and circuit components capable of serving as frequency converters. Among the tubes which may be employed are triodes, pentodes and pentagrid (five-grid) tubes. The oscillator may be coupled inductively or capacitively to either the cathode, control grid, screen grid, or suppressor grid of the mixer. It may even be coupled to a special grid, called the "injector" grid, which is found in certain types of mixer tubes. Some pentagrid tubes are designed to combine the functions of oscillator and mixer in one tube. They are then known as "pentagrid converters."

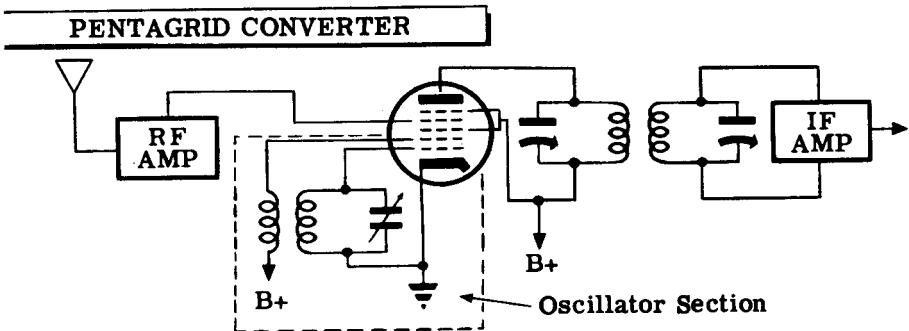
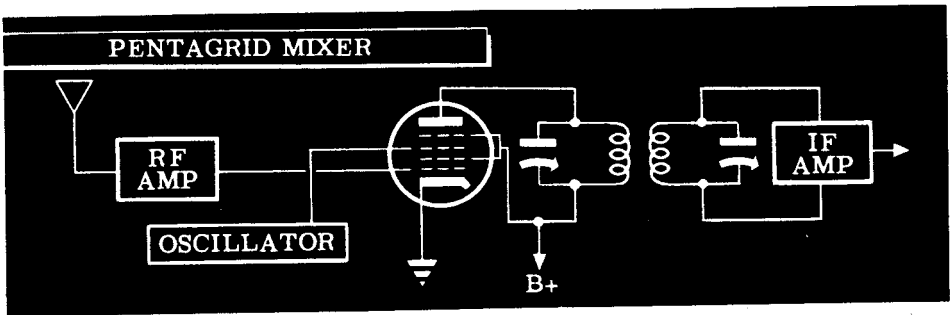
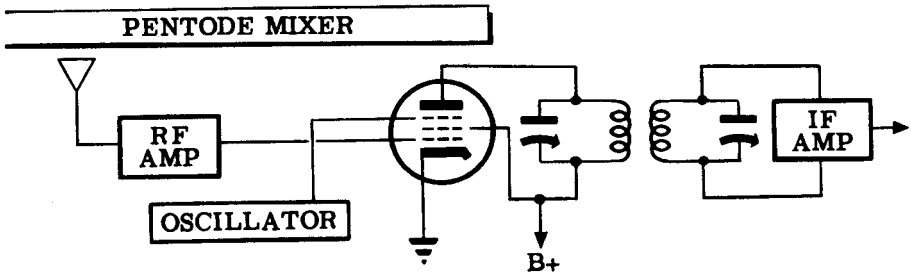

THE SUPERHETERODYNE RECEIVER

How the Mixer Stage Works (continued)

Most IF transformers are tuned by adjusting small mica trimmer capacitors to the correct frequency. This process of adjustment will be discussed later. The coils and capacitors are mounted in small metal cans which act as shields. Small holes in the tops of the cans make it possible to vary the value of the capacitors by turning adjusting screws without removing the shield.

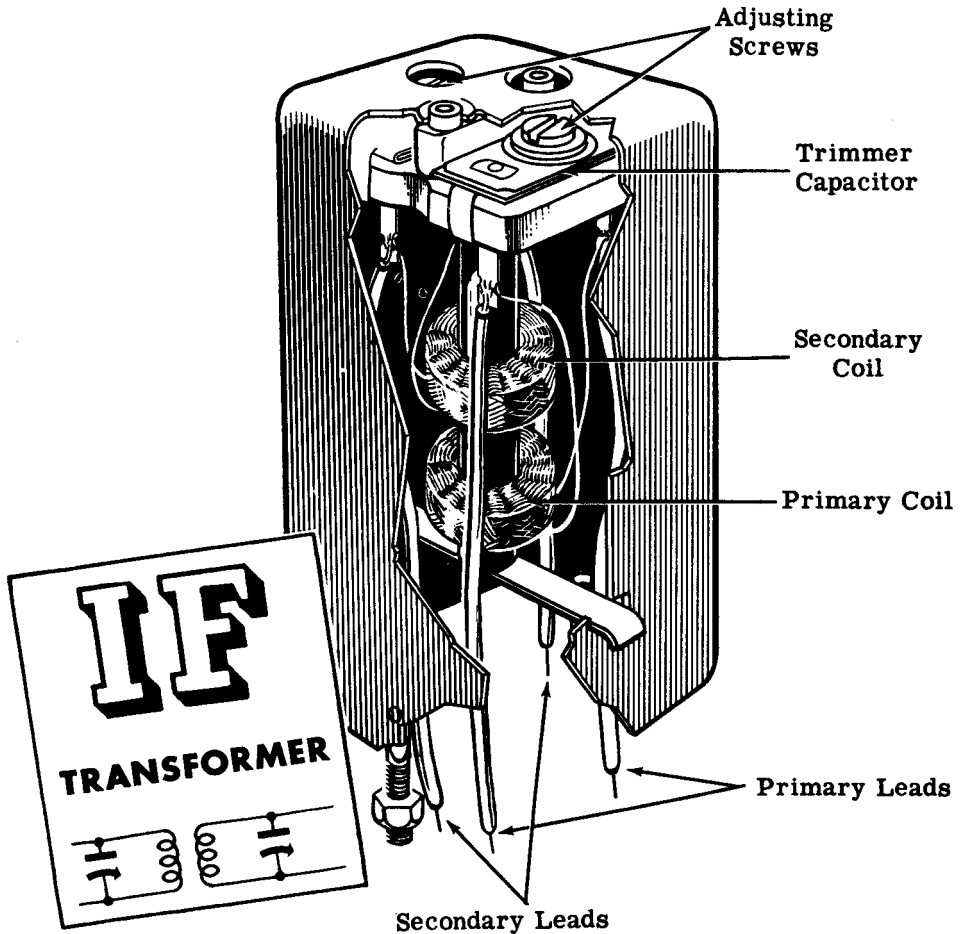

There are also some IF transformers that have powdered iron cores and fixed mica capacitors. Tuning is accomplished by turning a set screw which moves the iron core in or out of the coil. This type of transformer is known as a "permeability-tuned" transformer. No matter what method is used to tune the transformer, you will find that nearly all IF transformers are double tuned. This means that both primary and secondary are tuned to the intermediate frequency. This produces a very high degree of selectivity.

THE SUPERHETERODYNE RECEIVER

How the IF Amplifier Works

The intermediate-frequency amplifier is permanently tuned to the constant difference in frequency between the incoming RF signal and the local oscillator. The tuning of the IF amplifier stage is accomplished by means of two tuned IF transformers. The one associated with the grid circuit of the amplifier is called the "input" IF transformer, while the one associated with the plate circuit is called the "output" IF transformer. The tubes employed in IF amplifiers are generally variable-mu pentodes.

Since this amplifier is designed to operate at only one fixed frequency, the IF circuits may be adjusted for high selectivity and maximum amplification. It is in the IF stage that practically all of the selectivity and voltage amplification of the superhet is developed. Simple superhet receivers may contain only one IF amplifier, while more complex receivers contain as many as three IF amplifier stages.

The intermediate frequency used most often in superhet receivers is 456 kc, although intermediate frequencies as low as 85 kc and as high as 12,000 kc or higher have been used in special types of superhet receivers. Using a low intermediate frequency, such as 175 kc, results in high selectivity and voltage gain, but also increases the possibility of image-frequency interference. A high intermediate frequency reduces the possibility of image interference, but also reduces the selectivity and voltage gain. The choice of 456 kc as the intermediate frequency for most receivers represents a compromise between these two rather undesirable extremes.

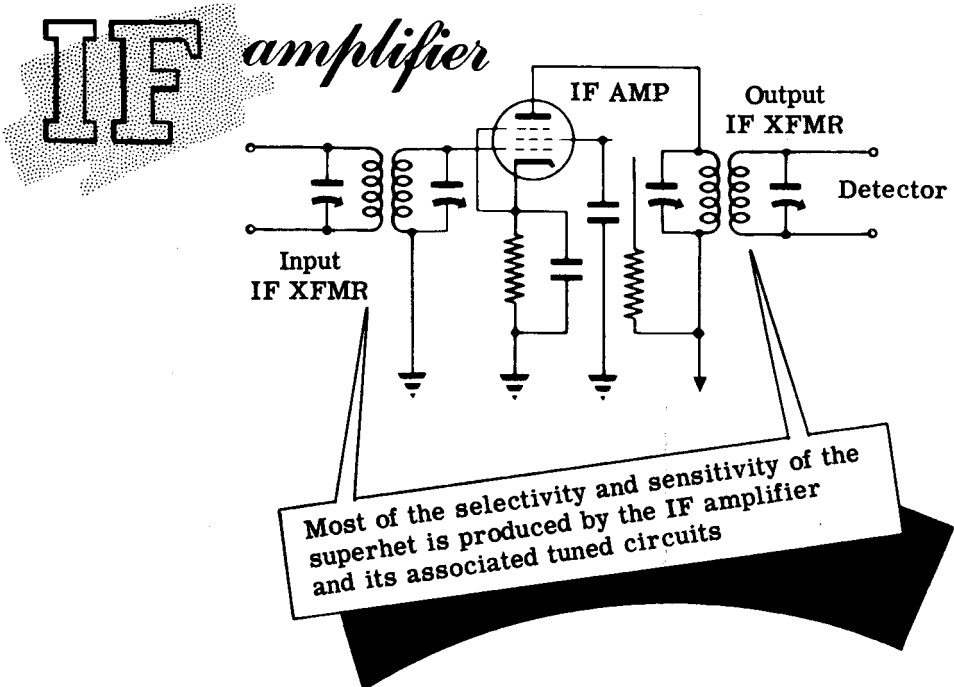

THE SUPERHETERODYNE RECEIVER

How the Detector Works

The conversion of the IF signal into an audio signal is accomplished by means of a diode detector. Since the mixer is sometimes called the "first detector," this diode detector is frequently referred to as the "second detector."

The second detector circuit in the superhet receiver will sometimes be combined in one tube with the first stage of audio amplification. The receiver's manual volume control and automatic volume control are also often included as part of the same tube circuit. The tube employed for this purpose may be a 6SQ7 which is a twin-diode high-mu triode. The diode section acts as the detector, and the triode section as the audio amplifier.

Since a detailed explanation of the operation of diode detectors has already been given under the topic TRF Receivers—Regenerative Detector, the operation of the diode detector which is shown in the accompanying circuit diagram will be described only briefly.

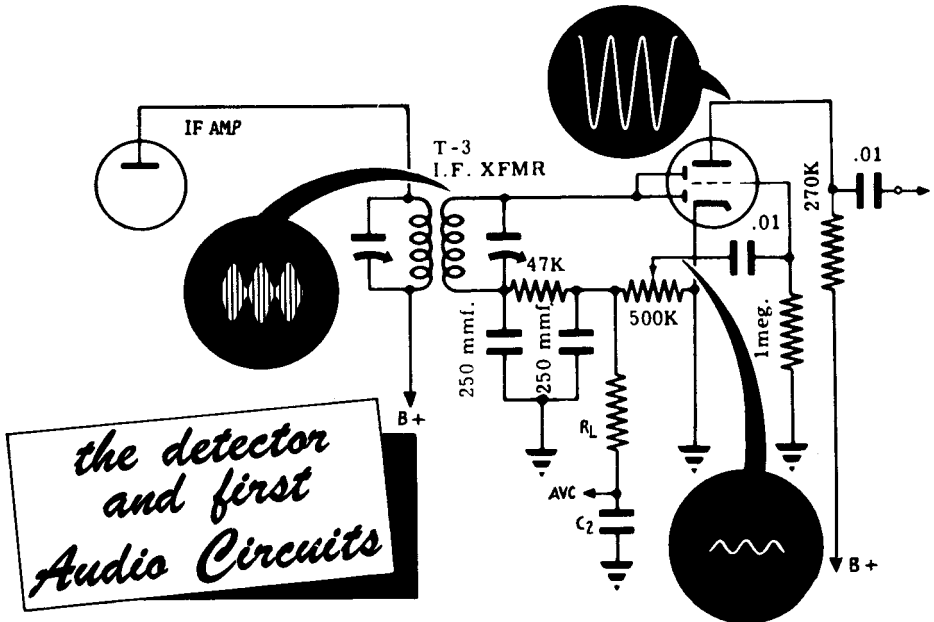

The diode acts as a rectifier and conducts current during that half of the signal cycle in which the plate is made positive with respect to the cathode. During the other half-cycle, when the plate is negative, no current flows. This produces a pulsating direct current which contains two components, one of which is audio frequency and the other intermediate frequency. The filter circuit, consisting of the 47K resistor and the two 250 mmf capacitors, filters out the IF component. The audio component of the pulsating direct current produces an AF voltage across the 47K fixed resistor and the 500K potentiometer. The AF voltage is applied to the grid of first audio amplifier and amplified at the plate as shown. Automatic volume control (AVC) which you will study later is developed across capacitor C_2 .

THE SUPERHETERODYNE RECEIVER

How the Audio Amplifiers Work

The audio signal developed across the 500K potentiometer is taken off the sliding arm and applied to the grid of the first audio amplifier. The potentiometer is connected as a voltage divider and functions as a detector-output type of volume control. The triode acts as an audio amplifier which increases the voltage of the AF signal and passes it on to the last stage, which is known as the "second audio" or "final power amplifier" stage. The purpose of this stage is to amplify the signal output of the first AF stage until it is strong enough to operate a loudspeaker. Power output is the main consideration in this stage. The operation of the audio power amplifier has been discussed previously under TRF Receivers—Audio Amplifier Stage. It would be an excellent idea at this time to review the previous material dealing with audio power amplifiers before proceeding further.

How Automatic Volume Control Works

Atmospheric conditions may sometimes cause fading of signals coming from certain stations. The resulting output of the receiver may at one moment be loud enough to blast the listener from his seat, while it may fade during the next moment to the point of becoming inaudible. Also, as you tune from one station to another, the signal strength may vary in the same way. One method of preventing this is to have the operator continually adjust the manual volume control in such a manner as to keep the output constant despite variations in signal strength. A better way of solving this problem is by the addition of a circuit which will accomplish this task automatically—an automatic volume control or AVC circuit.

The function of the AVC circuit is to vary the sensitivity or gain of the receiver in accordance with the strength of the signal. It reduces the sensitivity when a strong signal comes in and increases the sensitivity when the signal becomes weaker. The result is that the output of the receiver remains fairly constant in strength despite variations in signal strength.

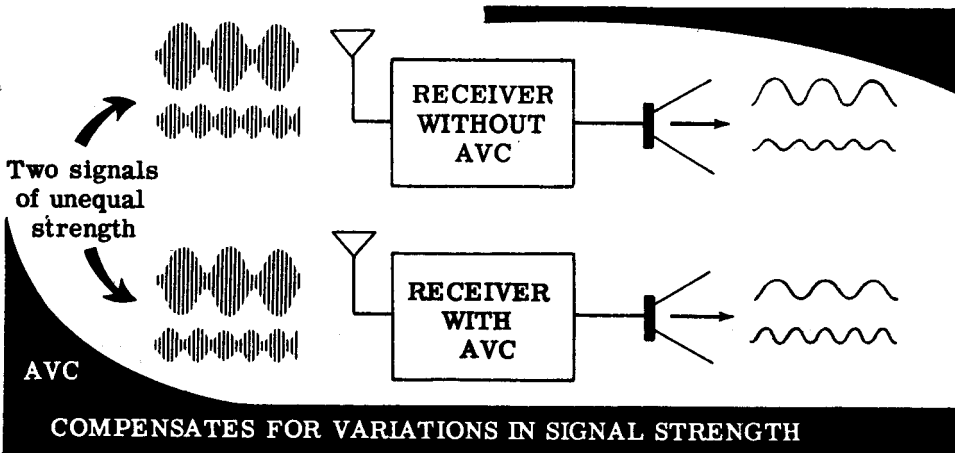

THE SUPERHETERODYNE RECEIVER

How Automatic Volume Control Works (continued)

The conventional AVC circuit most frequently encountered is incorporated in the diode detector stage. It requires that at least one, and preferably all, of the preceding IF amplifier, mixer or RF amplifier stages employ the variable- μ type of tube. It also requires some means of transferring the negative voltage that is developed by the AVC circuit to the control grid of these variable- μ tubes.

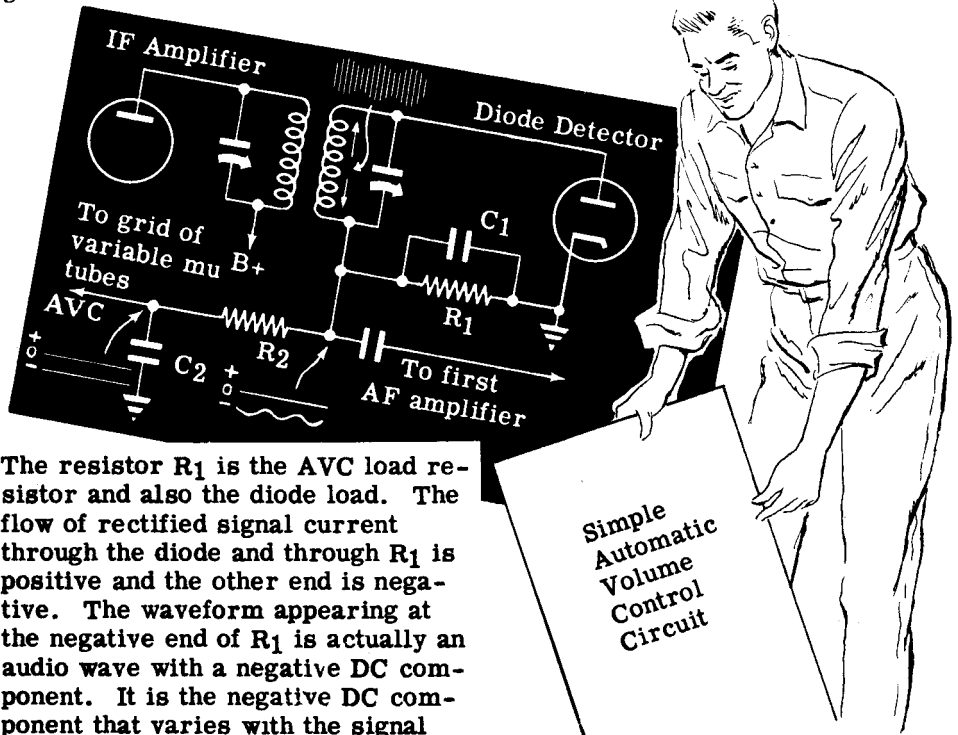

The resistor R_1 is the AVC load resistor and also the diode load. The flow of rectified signal current through the diode and through R_1 is positive and the other end is negative. The waveform appearing at the negative end of R_1 is actually an audio wave with a negative DC component. It is the negative DC component that varies with the signal strength. The AVC filter circuit, consisting of R_2 - C_2 , filters out the audio and C_2 charges up to the negative DC component. It is this negative voltage that is applied through the AVC line to the grids of the variable- μ tubes in the preceding stages.

The amount of negative voltage developed will vary in accordance with two factors. One is the relatively rapid variation in strength and amplitude produced by the audio signal at the transmitter during the process of modulating the carrier wave. The second factor is the slower variation in negative AVC voltage produced by variations in signal strength due to atmospheric conditions. If the rapid variations produced by the audio modulating signals were allowed to travel down the AVC line to the preceding IF or RF stages, undesirable effects would be produced. The AVC filter circuit, consisting of R_2 and C_2 , is added to remove these audio frequency variations of the negative AVC voltage. The slower variations in signal strength which show up as a slowly varying negative DC voltage are not bypassed and pass down the AVC line to the grids of the preceding amplifier stages.

THE SUPERHETERODYNE RECEIVER

How Automatic Volume Control Works (continued)

Since these preceding IF and RF stages employ variable- μ tubes, the amount of gain produced in each stage is dependent upon the amount of bias present on the control grid. When the signal increases in strength, a high negative AVC voltage is developed between one end of R_1 and ground. This negative voltage is applied through the AVC filter circuit and the AVC line to the control grids of the preceding stages, thus increasing the negative bias on these tubes. Because of this increased bias, there is a considerable decrease in the amount of amplification or voltage gain. In other words, the sensitivity of the receiver has been reduced. On the other hand, when a weak signal enters the receiver, a much smaller negative AVC voltage is developed. The bias on the amplifier tubes is reduced, resulting in considerably greater receiver sensitivity and voltage amplification for the weak signal. As far as the human ear is concerned, these variations in receiver sensitivity, as the signal strength varies, occur almost instantaneously, thus producing an output whose volume is reasonably constant.

IF AMPLIFIER, DETECTOR AND FIRST AUDIO AMPLIFIER

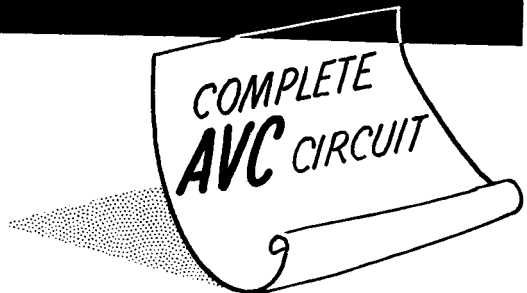
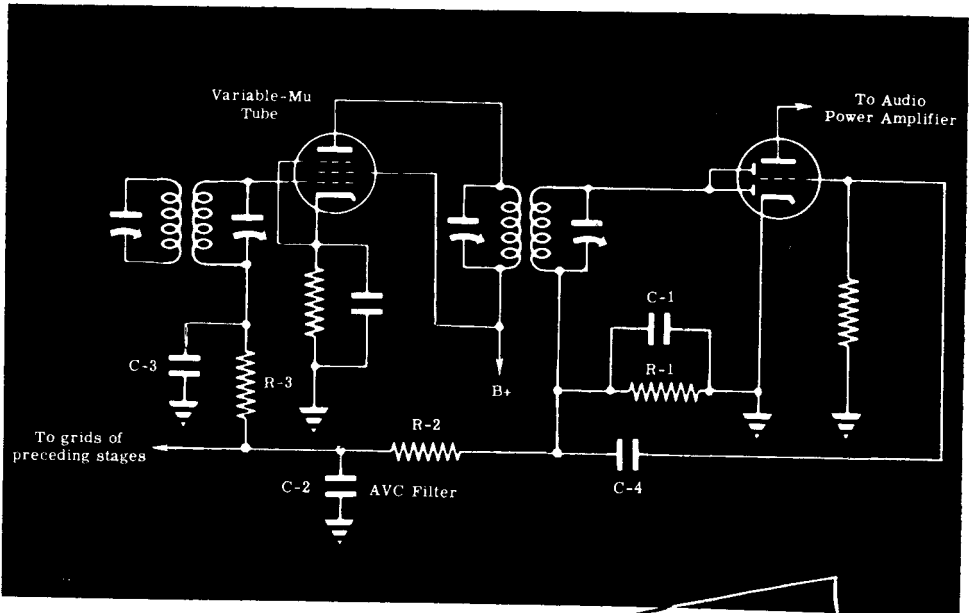

THE SUPERHETERODYNE RECEIVER

How the Beat Frequency Oscillator Works

It will be recalled from the topic entitled TRF Receivers—Regenerative Detector that in order to receive CW signals on a regenerative detector, it was necessary to make the detector oscillate. The frequency of these oscillations differed slightly from that of the incoming signal, in order to produce an AF signal by the process of heterodyning.

In superhet receivers this is often accomplished by means of a separate BFO, or beat frequency oscillator, capacitively coupled to the diode detector. The BFO may be a Hartley oscillator tuned to a frequency 1 kc above that of the intermediate frequency. Thus, if the IF is 456 kc, the frequency of the BFO is 457 kc and a 1-kc audio signal will be produced in the diode detector. The frequency of the BFO is variable over a small range, making it possible to vary the pitch of the resulting beat note until a satisfactory tone is produced.

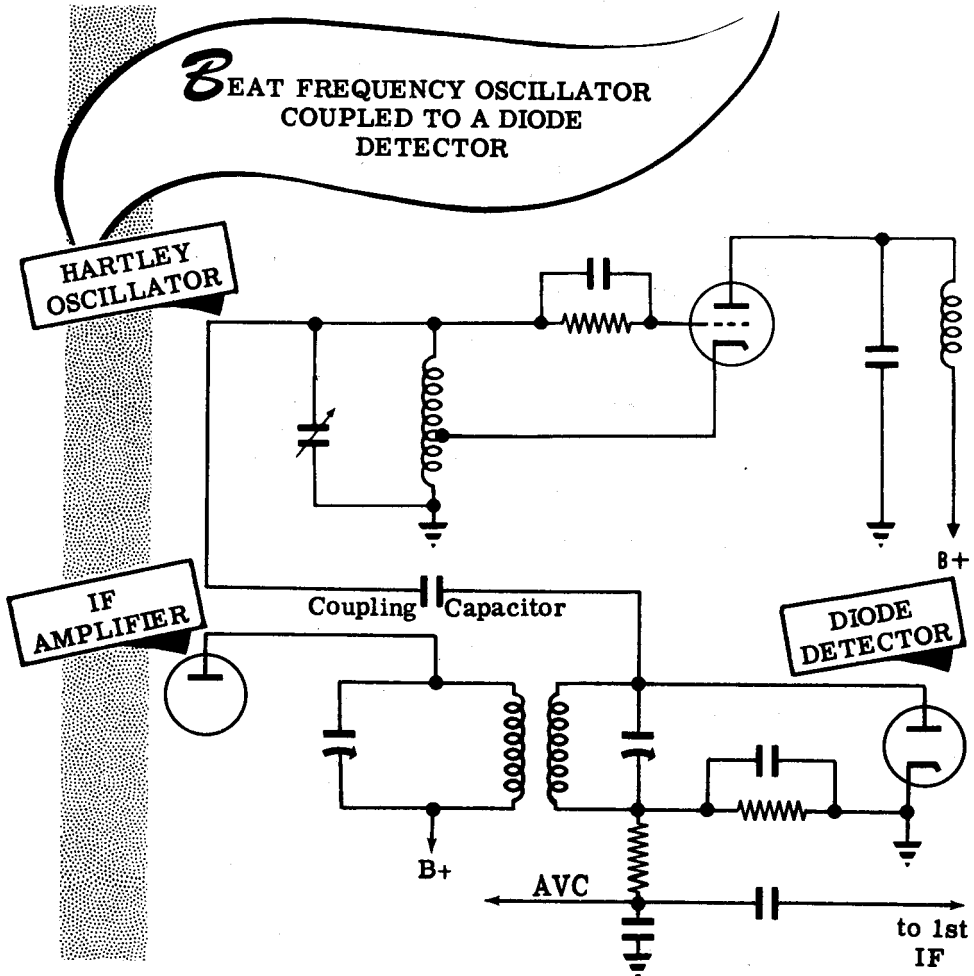

THE SUPERHETERODYNE RECEIVER

Complete Schematic of a Superheterodyne Receiver

The stages shown below include: a mixer, a local oscillator, one IF amplifier, a diode detector, an audio voltage amplifier, an audio power amplifier and a rectifier.

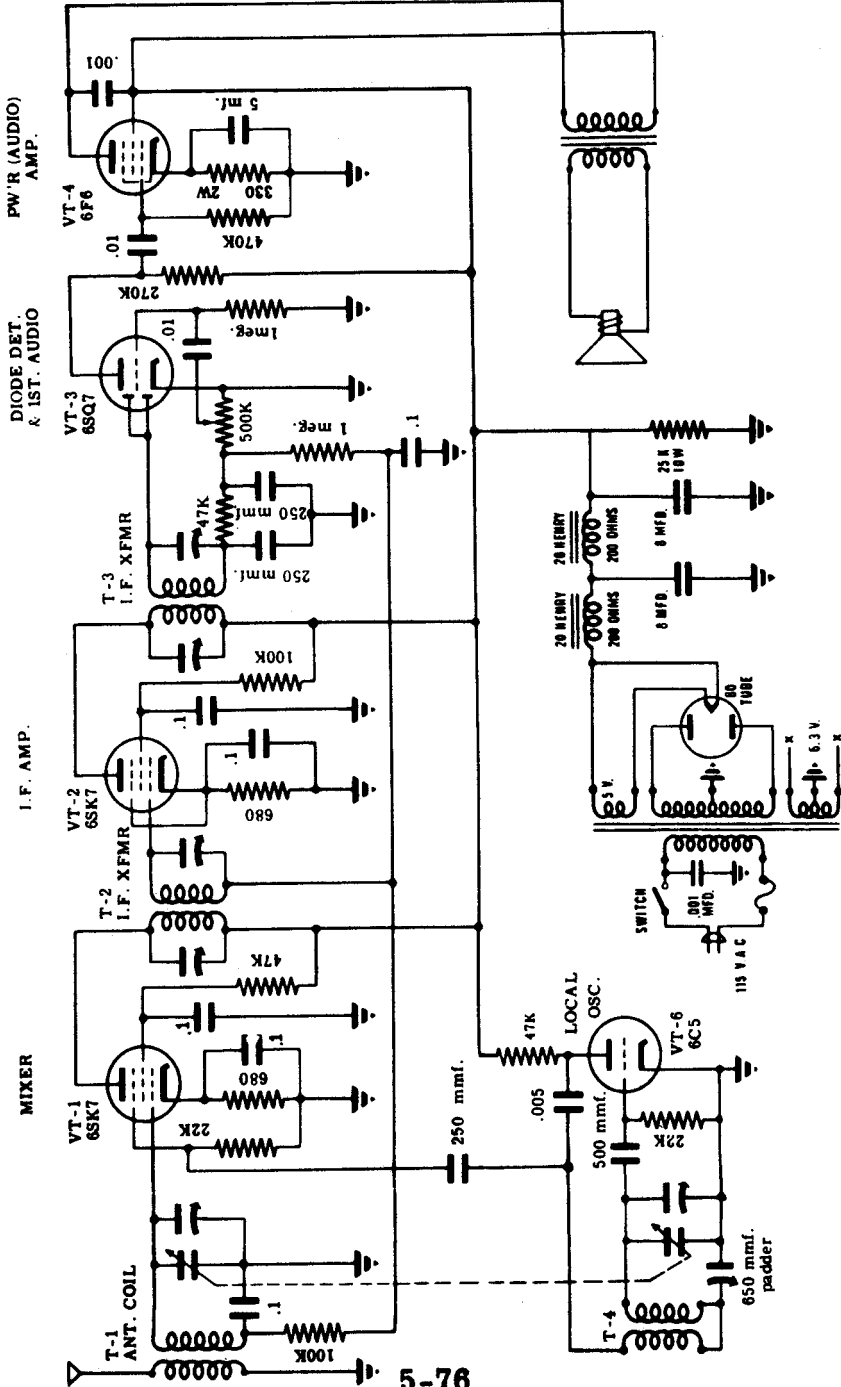

THE SUPERHETERODYNE RECEIVER

Analysis of the Local Oscillator Stage

THE *Local Oscillator*

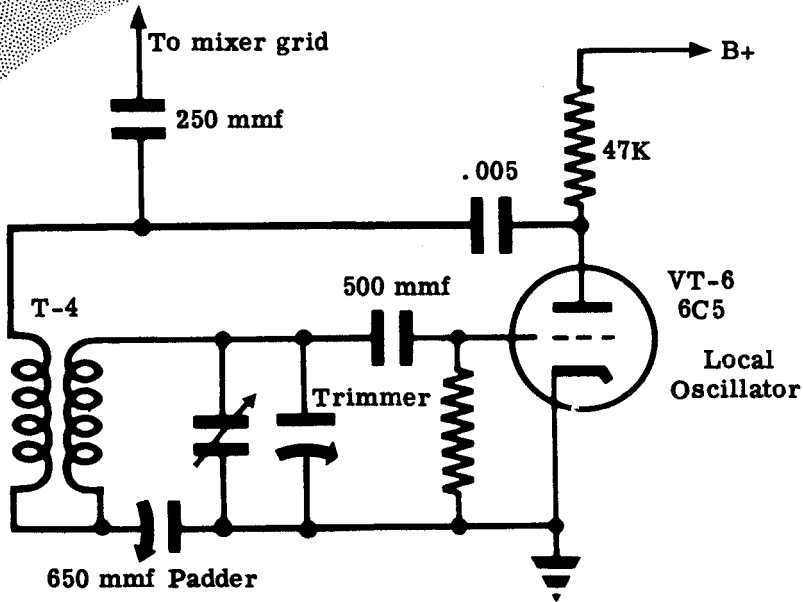

Now that you have seen the complete schematic of a superhet, it will be worth your while to spend a little time analyzing the function of the circuit components used in the oscillator, the mixer, and the detector stages.

The local oscillator circuit is basically that of an Armstrong (tickler coil) oscillator. Feedback is accomplished inductively using coil T-4. The variable tuning capacitor is ganged to the variable tuning capacitor of the mixer stage. The 650-mmf capacitor is a padder capacitor. It is used to make adjustments in the process of aligning the oscillator tuned circuit. It also serves to reduce the total capacity of the oscillator tank circuit so that the oscillator resonates at a frequency higher than that of the incoming signal.

The 500-mmf capacitor is a grid capacitor used to couple the tank circuit to the grid, while the 22K resistor is the grid-leak resistor. The 47K resistor is a plate load resistor which also blocks RF from going toward the power supply, and the .005-mfd capacitor couples the RF output of the plate circuit back to the tickler coil while effectively blocking the flow of direct current. Finally, the 250-mmf capacitor is used to couple the output of the oscillator with the suppressor grid of the mixer.

THE SUPERHETERODYNE RECEIVER

Analysis of the Mixer and IF Stages

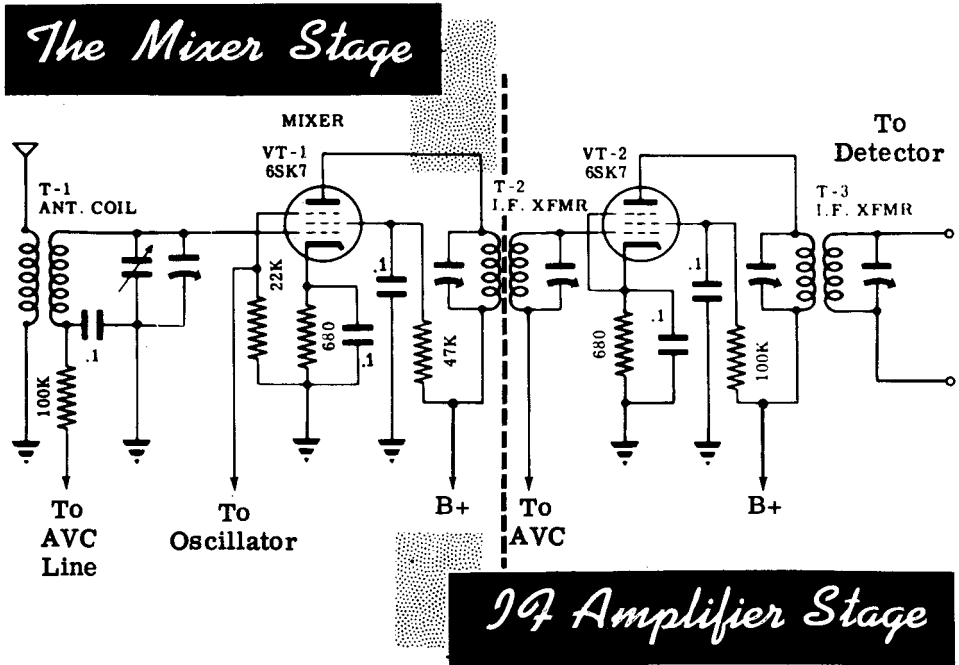

T-1 is the antenna coil used to couple the antenna with the control grid of the mixer. The variable tuning capacitor is used to tune the receiver to the desired station. It is ganged to the variable capacitor of the oscillator tank circuit. The signal from the oscillator is impressed upon the suppressor grid, and the 22K resistor is used to provide a path to ground for electrons that may collect on the suppressor grid. The 680-ohm resistor is a cathode bias resistor, while the 0.1-mfd capacitor in parallel with it is used to bypass the RF signal around the cathode bias resistor. The 100K resistor and 0.1-mfd capacitor connected to the bottom portion of the secondary winding of the antenna coil act as a decoupling network whose function is to keep the RF signal out of the AVC line. The 47K resistor and 0.1-mfd capacitor connected to the screen grid function as the screen grid voltage-dropping resistor and bypass capacitor respectively. T-2 is the input IF transformer which couples the 456 kc IF signal found in the plate circuit of the mixer with the grid circuit of the following IF amplifier.

The 680-ohm resistor and 0.1-mfd capacitor found in the cathode circuit of the IF amplifier serve as the cathode bias resistor and bypass capacitor respectively. The 100K resistor in the screen grid circuit is the screen grid voltage dropping resistor, while the 0.1-mfd capacitor in the screen circuit is the screen grid bypass capacitor. T-3 is the output IF transformer used in couple the IF amplifier with the diode detector. Both IF transformers are permanently tuned to the intermediate frequency—456 kc.

THE SUPERHETERODYNE RECEIVER

Analysis of the Diode Detector and First Audio Stages

DIODE DETECTOR AND FIRST AUDIO AMPLIFIER

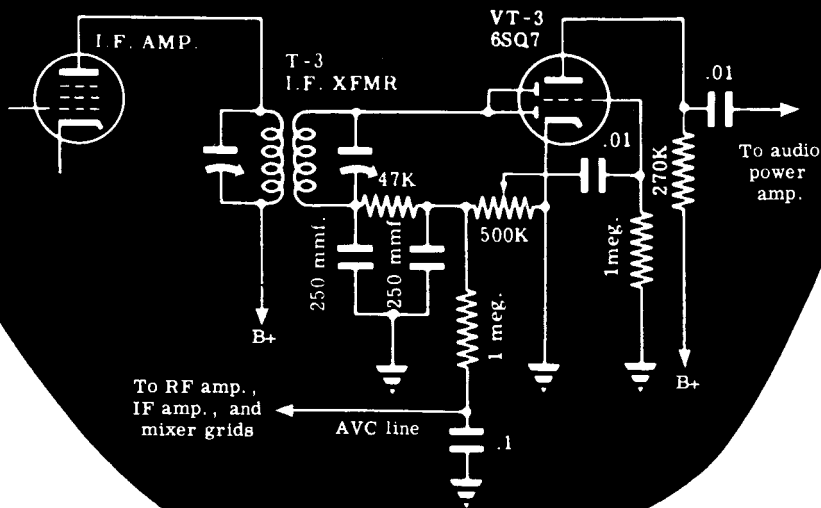

The two 250-mmf capacitors function as the detector filter capacitors. Their purpose is to bypass the IF component of the signal to ground around the 47K and 500K diode load resistors. The 47K resistor is part of the filter network, while the 500K potentiometer also acts as a bleeder resistor across the filter. It controls the amount of detector output delivered through the .01-mfd coupling capacitor to the grid of the first audio amplifier and thus serves as a volume control.

The 1-meg. resistor and 0.1-mfd capacitor in the AVC line filter out the relatively rapid variations in AVC voltage produced by the audio component of the signal. They allow the slower variations in AVC voltage produced by variations in signal strength to pass unimpeded down the AVC line.

The 1-meg. resistor connected to the control grid serves as a path to ground for any electrons that may accumulate on the grid. The 270K resistor acts as the plate load of the first audio stage, while the .01-mfd capacitor in the plate circuit couples the output of the first audio amplifier to the grid of the audio power amplifier.

The circuit of the audio power amplifier does not require further analysis, since the circuit is the same as that of the power amplifier previously discussed under the topic entitled TRF Receivers—Audio Amplifier Stage.

THE SUPERHETERODYNE RECEIVER

What Alignment Is

The superheterodyne receiver must be adjusted almost as carefully as a jeweler adjusts a watch. This process, called "alignment," is the same for all superheterodyne receivers. You align your superhet to make it operate at its best output. The purpose of alignment is to get the maximum gain in the superhet receiver for any setting of the main tuning dial. When the dial is set to receive a station transmitting at 980 kc, you want the receiver to give the greatest gain at 980 kc. The same thing must be true for every setting on the dial. The tuned circuits—RF, local oscillator, and IF—must be adjusted to give always the maximum output. How does the superhet circuit have to be tuned to give the greatest gain for each dial setting?

1. The IF transformers must be tuned to the fixed IF frequency.
2. The RF tuned circuit must be tuned to the frequency on the dial.
3. The local oscillator must be tuned to give an output at each setting of the main dial that is above or below the dial setting or RF frequency by a difference equal to the IF frequency.

A review of the superheterodyne circuit will show you how the tuning is done in the circuit itself. The diagram below includes all the tuned circuits in the receiver. The tuned circuits in the IF transformers are fixed to give maximum gain at the IF frequency. The RF circuit in the mixer grid is gang-tuned with the local oscillator. The trimmers on the two-gang variable capacitor and the padder capacitor in the local oscillator tank circuit are adjusted to keep the frequency difference between the RF circuit and the local oscillator constant at the IF frequency. For any setting of the dial, the local oscillator output must be above (or, in some sets, below) the received RF signal by the fixed difference of the IF frequency.

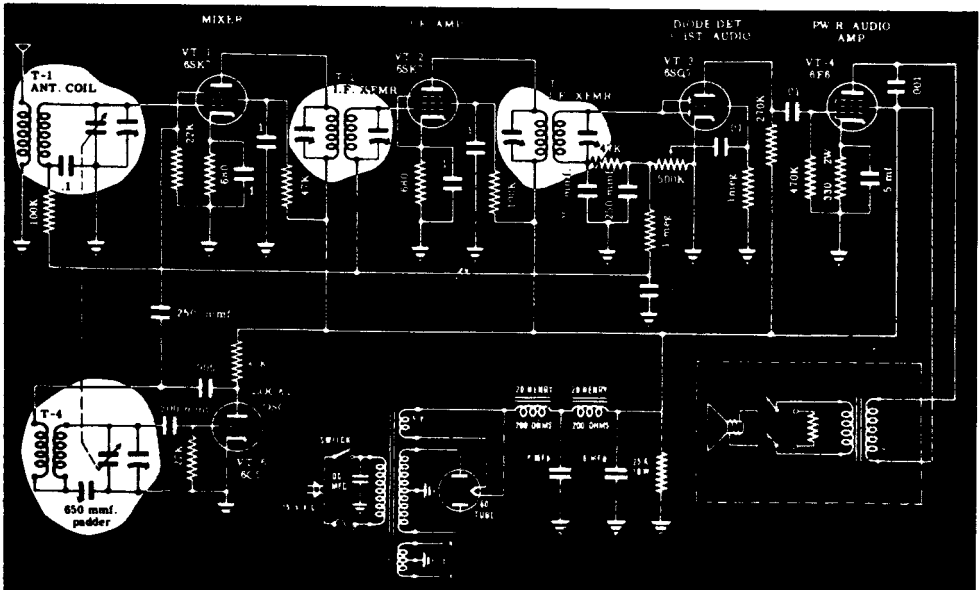

THE SUPERHETERODYNE RECEIVER

The Alignment Procedure

There are only three steps to follow to get the RF and the local oscillator tuned circuits adjusted in such a way that at any dial setting, there will be the best "tracking" possible. Perfect tracking would mean that as the RF tuning is varied, the local oscillator tuning will vary so as to maintain a fixed frequency difference.

**PERFECT
TRACKING**

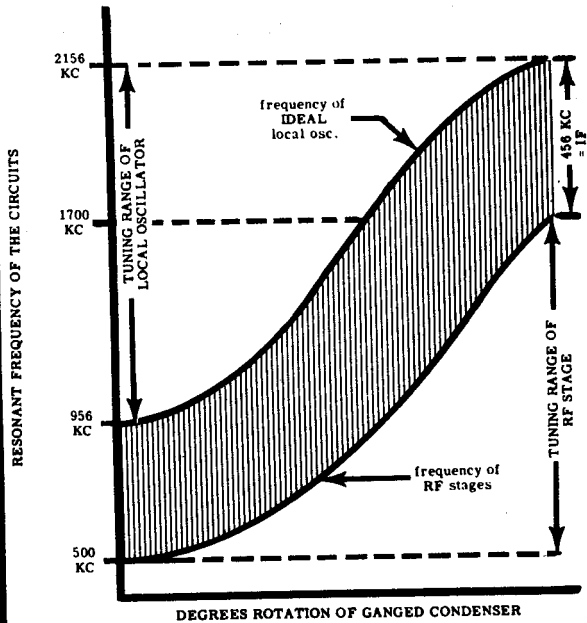

The first step is to adjust the trimmers on the two-ganged variable capacitor. Since these trimmers are in parallel with the tuning capacitors, they affect the total capacitance more at the high frequency end of the band (when the variable capacitor has minimum capacitance) than at the low frequency end. For this reason, the trimmers will be adjusted at 1500 kc, which is close to the high end of the broadcast band.

The local oscillator padder is in series with the tuning capacitor and will have more effect on the total capacitance when the tuning capacitor has maximum capacitance. This occurs at the low end of the tuning range where the plates of the variable capacitor are fully meshed. The padder will be adjusted at 600 kc, the low end of the band.

There is a problem here. When the 600-kc signal is fed into the input, even if the RF circuit is not set exactly to 600 kc, it is possible to adjust the local oscillator's padder for a maximum output; but this is not the best setting of the padder although the local oscillator frequency is 1056 kc. The real maximum will occur when the local oscillator is adjusted to 456 kc above 600 kc at the same setting that the RF circuit is tuned to 600 kc. The correct adjustment is achieved by a process called "rocking in." In rocking in, you make adjustments of the padder at several settings of the tuning dial in the vicinity of 600 kc. The setting at which the maximum output is greatest is the correct one. The local oscillator padder has been adjusted so that the local oscillator frequency differs from the resonant frequency of the RF circuit by 456 kc.

After the padder has been properly adjusted, you will tune back to 1500 kc, inject a signal of 1500 kc, and readjust the trimmer capacitors at the high end of band.

THE SUPERHETERODYNE RECEIVER

What Sensitivity Measurements Are

Sensitivity measurements are used to determine how sensitive a receiver is. A receiver may be operating normally, as far as your ear or even an oscilloscope can detect, but, if the overall gain of the set is low, you may not be able to receive weak signals. This would only show up by measuring the overall gain of your receiver and comparing the results with the overall gain of a standard receiver.

If a receiver was tested and found to have low sensitivity, the cause would then have to be determined. This would be done by checking the gain of each stage and comparing the results with some standard, thereby determining which stage has the low sensitivity. This trouble is almost always due to a weak tube in the stage which has low sensitivity.

Consider a typical broadcast-band receiver. Broadcast receivers are not designed to be very sensitive since very powerful stations are relatively close to the receivers. In these receivers, a loss of sensitivity would mean you would turn up the volume control and nothing more. Therefore, sensitivity measurements are not necessary. Only when reception becomes so poor that it is uncomfortable or impossible to hear a station, would you attempt to repair the receiver.

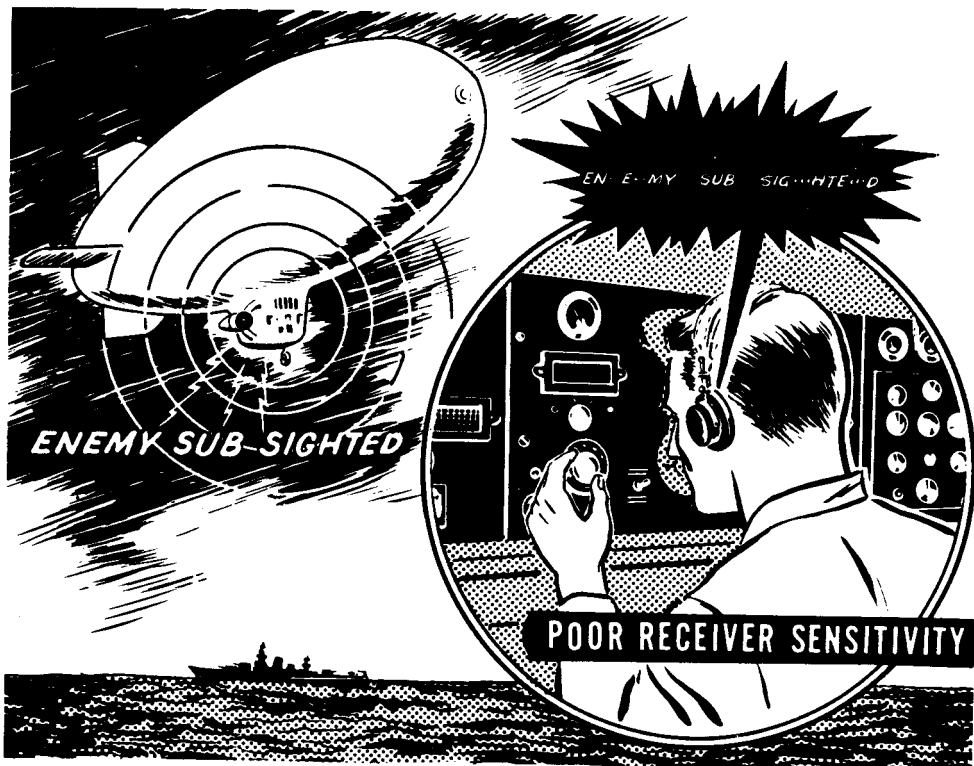

THE SUPERHETERODYNE RECEIVER

The Importance of Sensitivity Measurements

In some receivers, sensitivity measurements are very important. In a radar or sonar receiver, lack of sensitivity would mean that distant targets which should be detected would not be noticed at all. Decreased gain in a communication receiver would mean that weak signals could not be heard. If any of these devices have low sensitivity, you could not discover this fact by operating them, since you usually have no way of obtaining all the necessary data. You can't tell that a distant target is present unless you pick it up; you can't tell that a weak, distant transmitter is calling you unless you hear the message. Your only check on the performance of the receiver is through sensitivity checks.

Here is the typical way sensitivity measurements would be made with receiving equipment. An output meter is used to measure the output of the last stage of the receiver. The instruction book for the piece of equipment will tell how many microvolts are required as the input to this receiver for a standard output as measured on the output meter. Using a signal generator which has a calibrated output, you inject a signal of the proper frequency into the receiver input. You adjust the signal generator output until you read the standard amount of output on the output meter. By comparing the input you needed with the instruction book's data, you can tell if the receiver is working up to par. If the input you used is larger than that stated in the instruction book, your receiver has too low a sensitivity. You would then take stage-by-stage sensitivity measurements to determine the weak stage.

Starting with the last stage of the receiver, you inject a signal of proper frequency and adjust the signal generator output until the standard receiver output is obtained. If the input you used compares well with the instruction book data, the last stage of the receiver is working properly. You repeat this procedure for each stage, working backwards from the last stage. The stage that requires a larger input than that specified in the instruction book is the stage with low gain.

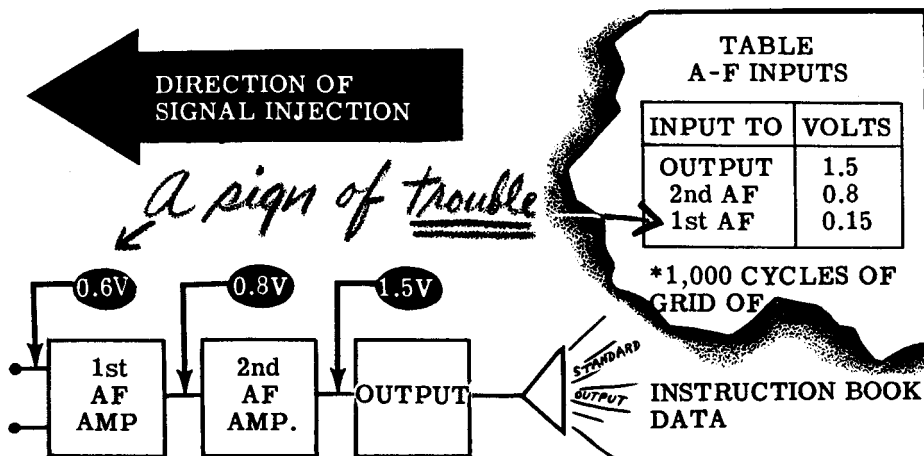

THE SUPERHETERODYNE RECEIVER

Demonstration—Aligning the IF Section

The first part of the receiver to be aligned is the IF section. The instructor removes the oscillator tube to prevent any signal other than that of the signal generator from entering the IF strip. He also shorts the AVC signal to ground since the AVC circuit, if operative, would tend to broaden the receiver response and thus make it more difficult to align the receiver sharply. The 'scope or output meter leads are connected across the speaker and the signal generator test leads are ready to be applied to the various test points in the IF section.

With the receiver gain at maximum, a modulated 456 kc signal is injected into point 1, the grid of the IF amplifier. Using an alignment tool, the instructor adjusts the trimmers on the IF output transformer for a maximum output on the 'scope screen. As the 'scope signal increases with the adjustment, the RF control knobs are lowered.

Next the RF signal is injected into point 2, the grid of the mixer stage, and the trimmers of the IF input transformer are adjusted for a maximum indication on the 'scope.

The trimmers on both the IF transformers are again touched up slightly to obtain optimum alignment of the IF section.

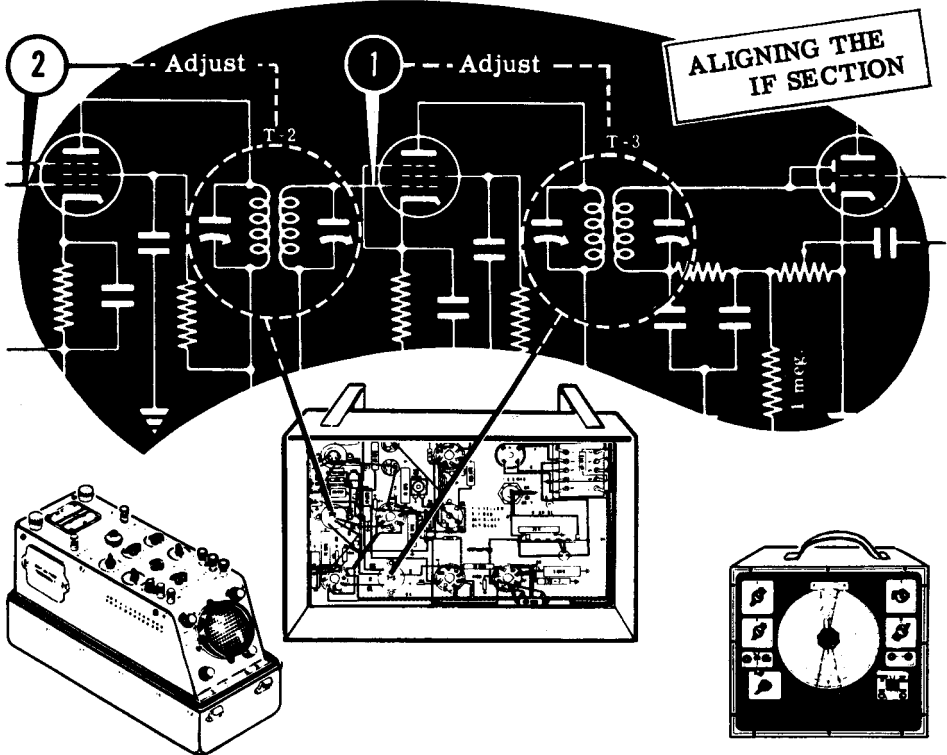

THE SUPERHETERODYNE RECEIVER

Demonstration—Aligning the Mixer and Oscillator

With the IF strip aligned, the RF tuned circuits in the grid of the mixer and the local oscillator are aligned next.

The instructor replaces the oscillator tube but leaves the AVC circuit shorted to ground. The signal generator test probe is moved to the antenna terminal and the signal generator is set to give a modulated RF output of 1500 kc. The receiver dial is set approximately to 1500 kc, and a signal is observed on the 'scope. With the alignment tool the instructor adjusts the oscillator and RF trimmers to give a maximum output on the 'scope screen. Now the RF circuit is tuned to resonate 1500 kc, and the oscillator is tuned to oscillate at 1556 kc.

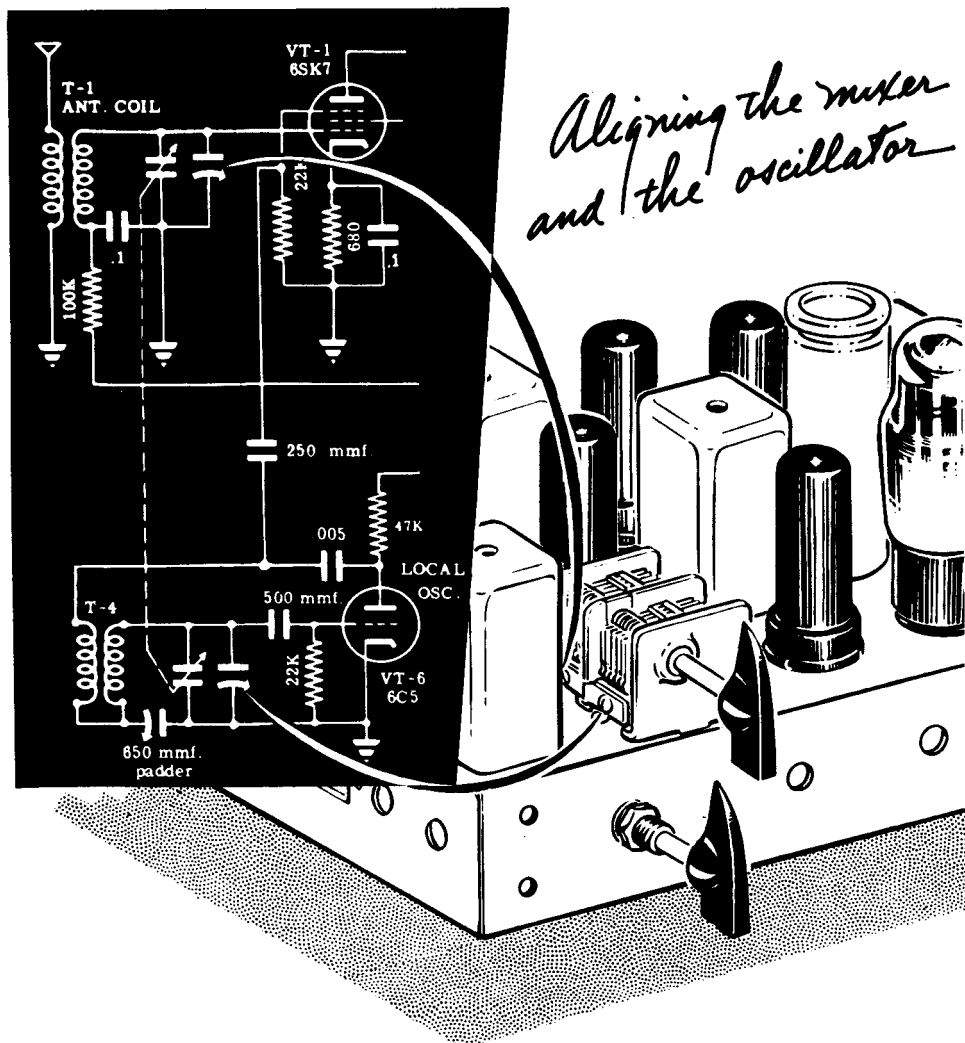

THE SUPERHETERODYNE RECEIVER

Demonstration—Aligning the Mixer and Oscillator (continued)

The mixer and oscillator tuned circuits must now be aligned at the low end of the band.

The instructor sets the signal generator at 600 kc and the receiver dial at 600 kc. He then adjusts the oscillator padder capacitor to give a maximum output on the 'scope. Now the oscillator is adjusted to oscillate 456 kc above the incoming signal of 600 kc.

Although the dial is set at 600 kc, there is no assurance that the RF tuned circuit is resonant to 600 kc. The ideal alignment for maximum output is to have the RF tuned circuit exactly resonant to 600 kc with the oscillator tuned to 456 kc above 600 kc. The ideal alignment is obtained by a procedure called "rocking in."

First the instructor notes the size of the 'scope image, and then he tunes the receiver in one direction slightly away from receiver dial reading of 600 kc. He readjusts the padder for a maximum output on the 'scope. If the 'scope image is greater than it was before, he has changed the setting of the tuning dial in the right direction. If the output is less, he must tune the receiver in the opposite direction from the 600 kc dial reading. Having found the right direction, he keeps on varying the setting of the tuning dial and adjusting the padder until an absolute maximum 'scope image is reached. At this point the RF circuit is tuned exactly to 600 kc with the local oscillator tuned to 1056 kc. Making sure not to change the setting of the tuning capacitor, the instructor loosens the knob set screw and repositions the knob so that the pointer now reads 600 kc. The final step in alignment is to touch up the alignment at the high end of the band.

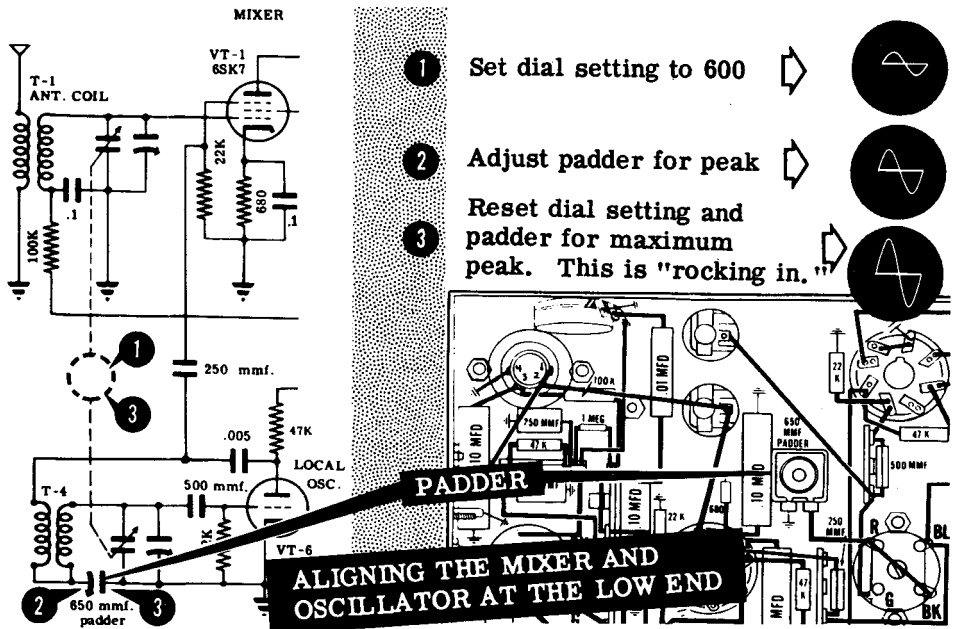

THE SUPERHETERODYNE RECEIVER

Review of the Superhet Receiver

SUPERHETERODYNE—A type of receiver in which the RF signal is converted to a lower frequency RF and then amplified before detection. It has much higher sensitivity, selectivity and stability than the TRF.

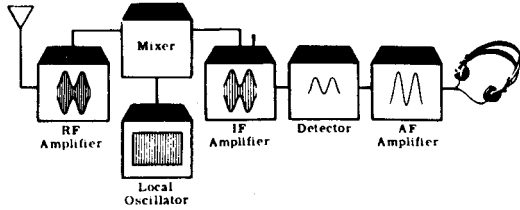

MIXER—This is the key circuit in a superhet. It takes the RF signal and beats it against the signal generated by a local oscillator. The resultant constant frequency signal is lower in frequency than the RF and thus is easier to amplify.

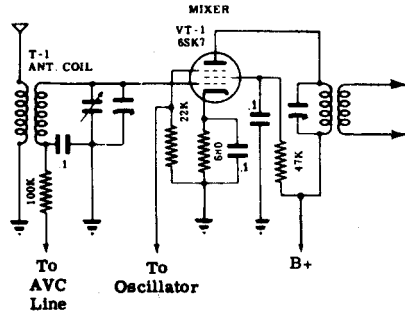

LOCAL OSCILLATOR

This circuit is tuned simultaneously with the RF tuned circuits in such a way that its output frequency is always 456 kc greater or less than the frequency of the signal being received. Its output is combined with the RF signal in the mixer, which thus always feeds a constant frequency signal to the IF amplifier.

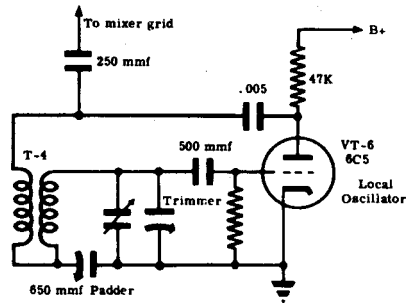

IF AMPLIFIER—The section of the superhet which amplifies the fixed frequency signal coming from the mixer. Its input and output are usually coupled by transformers in which the primary and secondary are tuned. This results in high selectivity.

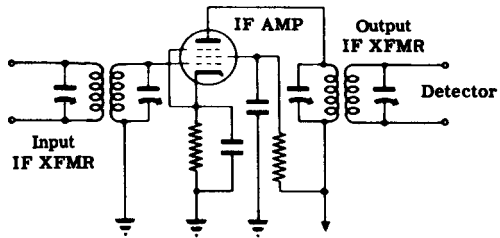

DETECTOR AND AF AMPLIFIER—These circuits perform the same functions as in the TRF receivers. In the superhet the diode detector is often combined with the first AF amplifier stage.

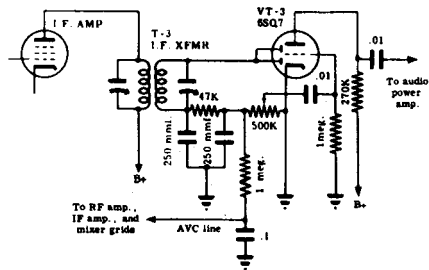

THE SUPERHETERODYNE RECEIVER

Review of the Superhet Receiver (continued)

AUTOMATIC VOLUME CONTROL (AVC)

—This circuit compensates for variations in signal strength. A diode rectifies the negative half of the signal and feeds the DC output to the RF and IF amplifier grids. When the signal increases the diode output increases, thus putting more negative bias on the RF and IF amplifiers and lowering their gain.

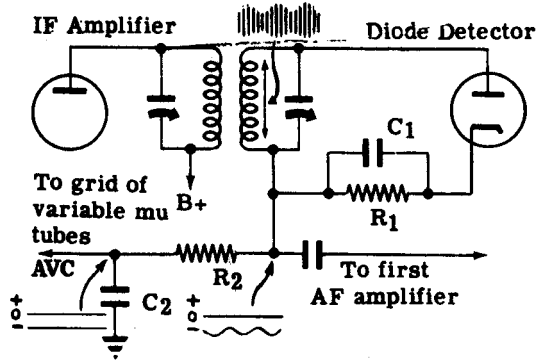

TRACKING—When the difference between the local oscillator frequency and the RF signal frequency is constant over the entire tuning range of the superhet, it is said to have perfect tracking. This is never achieved in practice.

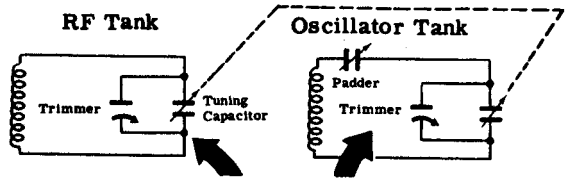

TRACKING: 456 kc difference over entire tuning range

BEAT FREQUENCY OSCILLATOR (BFO)

—This is an oscillator used when it is desired to receive CW signals with the superhet. Its output is tuned close to the frequency of the IF and is fed into the detector. It beats with the incoming signal, producing a beat note in the audio range. With a BFO, a CW signal is heard as a pure tone. Without a BFO, CW signals are heard as a soft hiss or not at all.

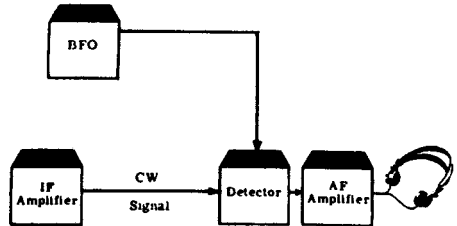
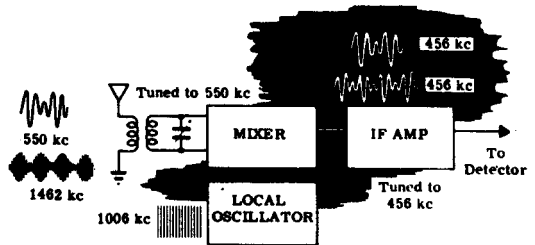

IMAGE FREQUENCIES—If the IF is 456 kc, then two signals (one 456 kc above and the other 456 kc below the oscillator frequency) will both send a signal through the IF amplifier and to the loudspeaker. One of them is the desired signal; the other is an image. The purpose of a tuned antenna coil and tuned RF amplifiers is to eliminate the image frequency.



TROUBLESHOOTING THE SUPERHETERODYNE RECEIVER

Review of the Troubleshooting Method

If you have to fix a defective piece of equipment, here is one way that you might go about finding the trouble source. If there is a complaint tag attached to a piece of equipment, get as much information as you can from it, so that you don't waste time looking for troubles that aren't there. In the event that there is no complaint tag, follow the procedure described in the following paragraphs.

Inspect the Equipment

This is a very important step—many defects can be found by using your five senses. Once you have heard a transformer sizzle and smelled the smoke, you will be able to spot a burned-out power transformer without even turning the chassis over. Visual inspection does not take long—in about two minutes you should be able to see the trouble if it is the kind that can be seen.

You should fully realize the significance of visible defects and you should know just how they can be recognized. Remember that even though you do find and repair a defect, you must prove to yourself that the equipment is operating properly and that there are no other defects. Usually, there will be only one trouble in a piece of equipment unless the faulty component has been caused to burn out by some other fault. When you find a trouble by visual inspection, try to imagine another trouble which could have caused the one you've located. If you merely proceed to replace the faulty component and then turn the equipment on, the replacement part may burn out again. The most obvious example is a fuse which burns out, gets replaced, and then the second one burns out. You must locate the cause of the trouble before you replace the faulty parts.



TROUBLESHOOTING THE SUPERHETERODYNE RECEIVER

Troubleshooting by Signal Tracing and Signal Injection

Devices such as radar, sonar and radio receivers are very complex. If you attempted to do troubleshooting on a radar receiver by means of voltage and resistance checks alone, you would have a long tiresome task ahead of you. There would be hundreds of voltage, current and resistance checks for you to perform, not to mention tubes and tuned circuits to be tested. And then there would always be the possibility that none of your checks would show you what was wrong, since static testing will not show up faults like misaligned tuned circuits, certain tube defects or defective automatic control circuits.

Fortunately, the signal injection method is an ideal way to locate quickly any receiver trouble.

Suppose you review the advantages of troubleshooting by signal tracing.

1. You can test each section of the receiver by putting in a signal and listening to the signal at the output or by examining the output with an oscilloscope.
2. You can determine immediately the defective section, since the signal at its output is either missing or distorted.
3. Knowing the section with the trouble, you can isolate the trouble to a particular stage by injecting a signal of the proper frequency and amplitude into the grid points, starting at the output and working back towards the input. The point at which the signal disappears or becomes distorted is the place to look for trouble.
4. Once the defective stage has been found the defective component can be isolated by using voltage and resistance checks.

Signal tracing and signal injection, therefore, enable you to find the trouble quickly and easily by greatly reducing the number of points to be tested. By the use of signal tracing, you can locate the stage which contains the trouble and sometimes, depending on the nature of the trouble, the faulty part. You also can narrow the trouble down to the particular stage or component with a minimum number of checks of those stages which are functioning properly.

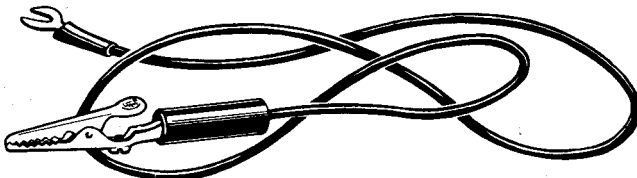

TROUBLESHOOTING THE SUPERHETERODYNE RECEIVER

Troubleshooting by Signal Tracing

The best way to locate the trouble is to trace a signal through the equipment, using either signal tracing or signal injection. Signal tracing and signal injection are basically the same thing. Each has some advantages over the other for the testing of different types of basic circuits. The basic purpose of these signal tracing methods is to locate the exact area of a trouble. Any break or short in the signal path can be located immediately because the signal will disappear at that point. If the trouble is due to an improper voltage on a tube or is due to a faulty tube, the signal will not pass (or will be distorted) between the grid and plate circuit of the tube. If the trouble is of this nature, it can be localized immediately to the specific tube, and then the exact trouble can be located by voltage and resistance checks and by trying a tube known to be good. Let's review the procedure for signal tracing and signal injection.

In the procedure for signal tracing, the normal signal input for a piece of equipment is connected to the input terminals. The 'scope is then used to trace the signal from the input towards the output. The point at which the signal disappears or becomes distorted is the point to look for the trouble.

Signal tracing can be used with practically every type of circuit that you will come across. In general, it is most useful in equipment where there is an audio signal. It may be used also in equipment where there is an RF signal of voltage amplitude high enough to be seen on the 'scope. Signals cannot be traced easily in receivers because of the low voltage RF signals present in a major part of the circuit.

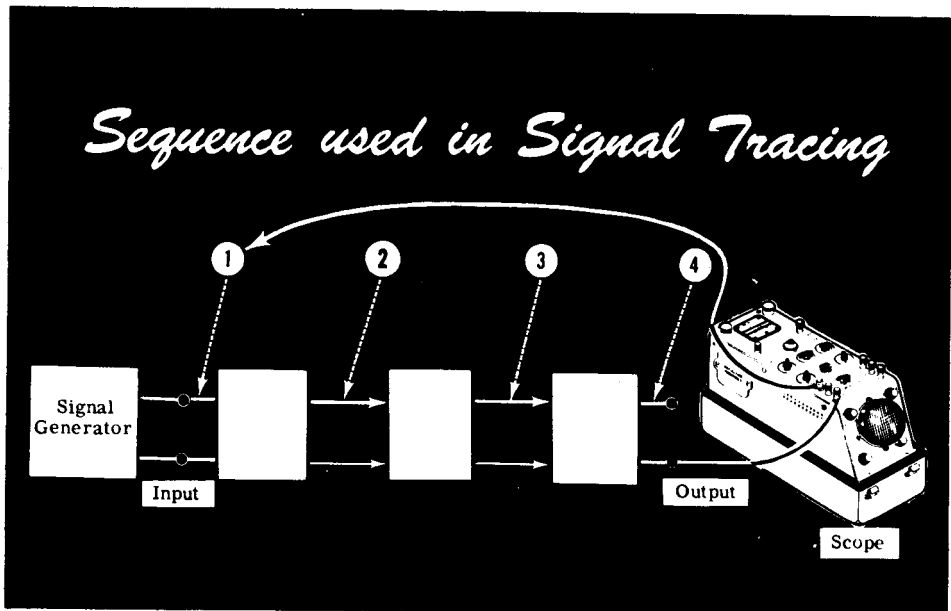

TROUBLESHOOTING THE SUPERHETERODYNE RECEIVER

Troubleshooting by Signal Injection

In the procedure for signal injection, the 'scope is permanently connected to the output of a piece of equipment. The signal generator is used to inject a signal of the proper amplitude and frequency into the various test points, starting at the output and working towards the input. Signal injection has the disadvantage of seeming to be a "backwards" procedure; actually it is basically the same as signal tracing.

Signal injection is used mainly with receivers and other similar equipment where there are high frequency amplifiers with a very low input voltage. The 'scope amplifier cannot amplify signals of radio frequency and the signal amplitude is much too low to be seen if it were connected directly to the 'scope vertical deflection plates. Signal injection solves this problem by using a signal generator to inject signals into various parts of the equipment. The amplifiers in the equipment under test will give a large enough gain so that the signal can be seen on the 'scope screen. The first stage to check is the last stage of the piece of equipment. If this last stage is operating normally, the next to the last stage is checked by feeding a signal into that stage and checking the output at the same point as before. It is because the 'scope is always observing the output of the equipment in signal injection that the last stage in the equipment is the first one to be checked. Just as in signal tracing, the point where the signal becomes distorted or disappears is the point to look for the trouble. For example, if the last stage is checked O. K. but when the signal is placed on the input to the next to the last stage, the output is not normal, the trouble is in the next to the last stage.

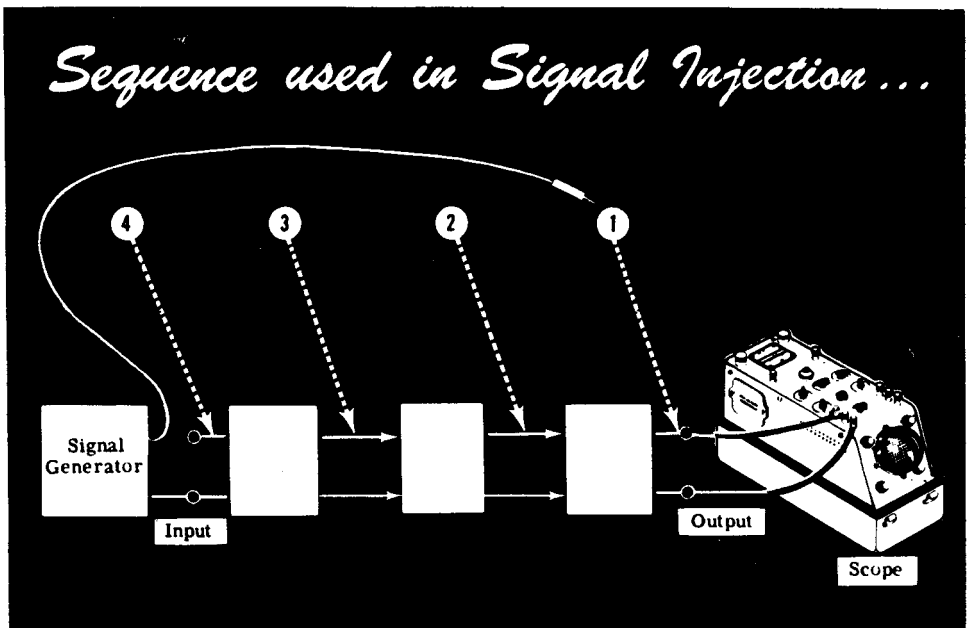

TROUBLESHOOTING THE SUPERHETERODYNE RECEIVER

Troubleshooting the Superheterodyne Circuits

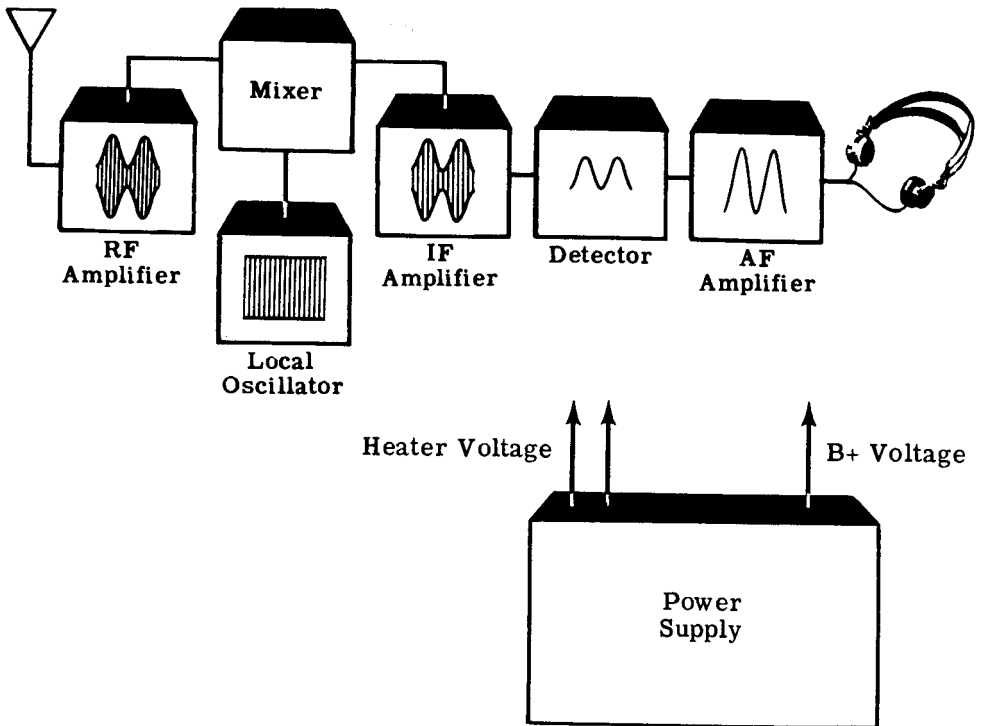

Here is an outline of how to troubleshoot the various sections of a super-het receiver.

1. The Power Supply

The power supply furnishes B+ and heater voltage to the various components of the receiver. In troubleshooting a power supply, the AC signal from the line cord is traced through the transformer, the rectifier tube, the filter circuit and up to the power supply bleeder resistor. The final B+ voltage should be quite free of hum, even with the 'scope Y GAIN control turned all the way up.

2. The Audio Amplifier

In troubleshooting the audio amplifier in a receiver, use the signal injection method because you will have to use that method for the rest of the receiver. The 'scope should be connected across the loudspeaker at the output transformer secondary. An audio signal should be injected into the various test points from the 'speaker towards the detector. The point at which the signal disappears or becomes distorted is the point to look for the trouble with your voltmeter and ohmmeter.

Use the 400-cycle audio output of the signal generator. Remember to use a .01-mfd blocking capacitor at the end of the probe to keep B+ out of the signal generator.

Troubleshooting the Superheterodyne Circuits (continued)

3. The Detector

The operation of the diode detector has been described in this section and the operation of two other basic types of detectors will be found in the TRF section. The detector takes a modulated RF (or IF) signal and separates the audio from the RF component. The high frequency component is bypassed to ground and the audio signal is connected to the audio amplifier. In troubleshooting a detector, a modulated RF (or IF) signal is injected into the detector input. If an audio signal corresponding to the modulation does not appear on the 'scope screen, there is trouble in the detector. Don't forget to use a 200-mmf isolating capacitor at the end of the test probe.

4. The IF Amplifier

The IF amplifier is an RF amplifier operating at a fixed frequency of 456 kc. The operation of the IF amplifier is similar to that of the RF amplifier described in the amplifier section—the only difference being that the IF amplifier operates at a fixed frequency and, because of this, may be designed for a much higher gain. By injecting a modulated 456-kc signal, you can first test the output transformer, then the tube and finally the input transformer. In all cases an audio signal should appear on the 'scope. This method will localize the trouble in any one of these three circuits—the rest is a job for the voltmeter and ohmmeter.

5. The Mixer and the Oscillator

The mixer stage selects the desired modulated RF signal from the antenna and mixes it with the unmodulated signal from the local oscillator. The local oscillator and the mixer tuning circuit have mechanically-ganged tuning capacitors which keep the frequencies of the selected signal and the oscillator 456 kc apart. As a result of the mixer tube action, a modulated 456-kc signal is fed into the IF amplifier no matter what the frequency of the incoming RF signal. Information on the operation of oscillator circuits will be found in the oscillator section.

The mixer is tested by first injecting a modulated 456-kc signal into the grid. If this signal passes through the mixer and appears as an audio signal at the final output, the mixer stage is operating. Then an RF signal is injected into the antenna input and tuned in by means of the antenna tuning circuit—an audio signal should appear on the 'scope. If no signal appears, there is trouble in the antenna tuning circuit or the oscillator circuit.

TROUBLESHOOTING THE SUPERHETERODYNE RECEIVER

Vacuum Tube Testing

Contrary to the belief commonly held by the general public, the first step in troubleshooting is not the testing of tubes. It is necessary to isolate the defective stage and to check that stage to reveal the defective component. However, since many receiver defects are due to faulty tubes, it is important that you become familiar with the operation of tube testing equipment.

Since burned-out filaments cause the majority of tube failures, it is usually possible to discover such defective tubes by removing them from the receiver and testing with an ohmmeter. A noisy tube, called a "microphonic tube," may be discovered by turning the receiver power on and then tapping each tube gently. If a blast of noise or a squeal is produced, the tube in question should be replaced.

In general, however, the most satisfactory method of determining whether some of the tube elements are shorted, and whether the tube's emission or transconductance characteristics are normal for its type, is to use a well designed tube tester. However, it should be noted that the tube tester cannot always be looked upon as a final authority for determining whether or not a particular tube will operate satisfactorily in a given receiver. This is due to the fact that this tube might be operating in the receiver on a portion of its characteristic curve which is not covered in the tube tester, or it might be operating in the set with voltages much higher or lower than those used in the tube tester. All deviations from normal readings should make a tube liable to suspicion. An excessively high reading may indicate a defective tube as readily as one that is too low.

The check for filament continuity and for shorted tube elements is generally performed as the first part of the testing procedure. If the filament is found to be open, it is useless to attempt further testing of that tube. If shorted elements are discovered, it is not advisable to test further, as the shorted elements may blow fuses or damage instruments in later tests. Filament continuity and shorted elements are usually indicated by the lighting of a small neon or pilot lamp on the instrument panel.

If the tube passes the short and filament continuity test, it is next tested for merit or quality. The greatest difference between various types of tube testers is in the selection of a suitable characteristic for the quality test. Testers are divided on this basis into two great classes, the emission type and the transconductance type.

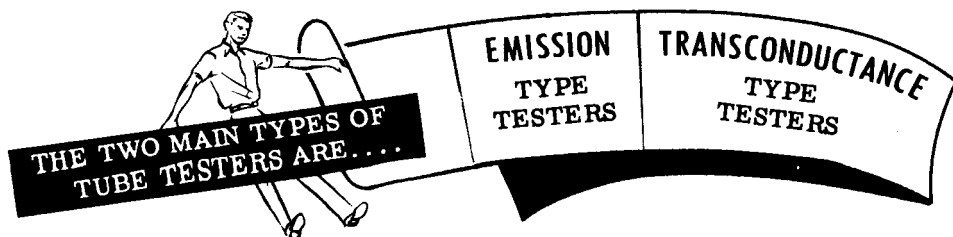

Vacuum Tube Testing (continued)

The emission-type tester determines the merit of the tube by measuring the amount of cathode current flowing when the filament is operated at its rated voltage and a positive voltage is applied to the plate. Since it is desired to measure only cathode emission in this test, the control grid, screen grid and suppressor grid are connected to the plate. Therefore, all tubes, whether they are diodes, triodes, tetrodes or pentodes, are tested as diodes. It is the simplest and cheapest method of testing the quality of a tube, but it is also the least satisfactory method.

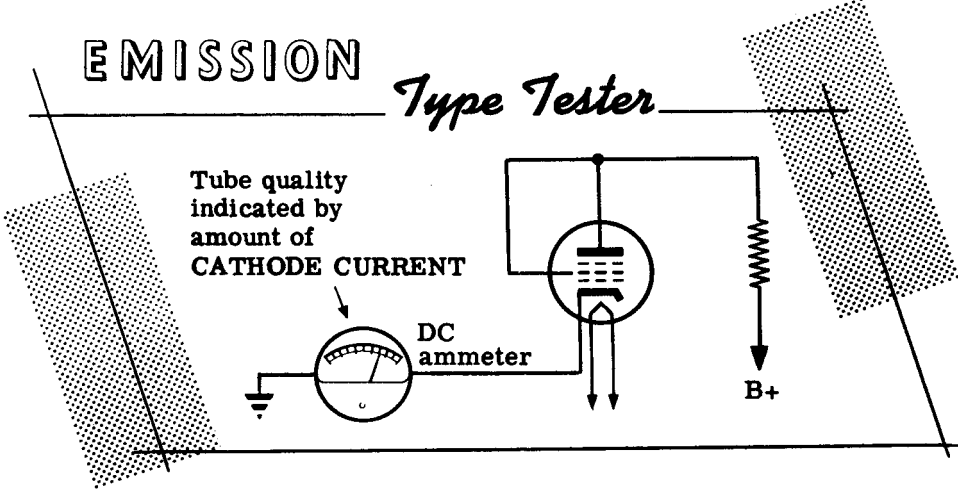

The mutual conductance or transconductance type of tester simulates the normal operation of the tube by applying a known signal to the grid and measuring the strength of the amplified signal in the plate circuit by means of an output meter. Since this procedure is performed under conditions which resemble the actual operating conditions of the tube in a receiver, the results obtained by using a transconductance-type tester give a better indication of a tube's serviceability than the results obtained from an emission-type tester.

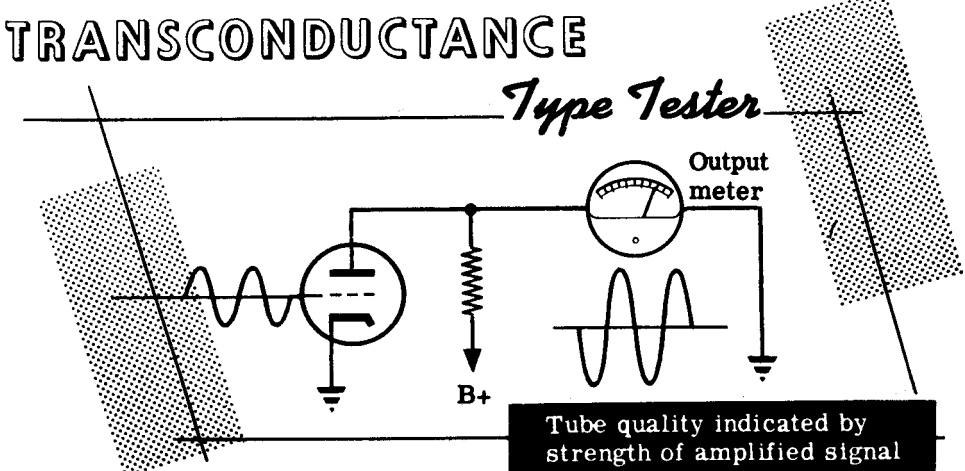

RECEIVERS

Review of Receivers

ANTENNA FUNCTION—The purpose of a receiving antenna is to pick up electromagnetic waves radiated by transmitting antennas. These waves, in cutting the antenna, induce voltages in it, causing a current to flow. The current flows into the input of the receiver, where it generates a signal which is amplified by the receiver circuits.

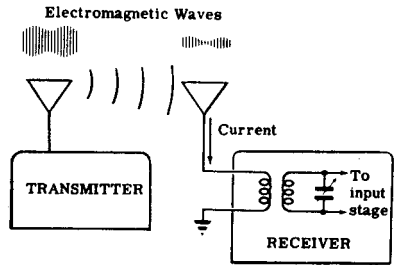

DIRECTIONAL CHARACTERISTICS

The position of a receiving antenna, relative to the transmitting antenna, will determine the strength of signal that it picks up. If a loop receiving antenna is broadside to a loop transmitting antenna, the signal picked up will be of maximum amplitude. If the loop is turned so that its edge faces the broad side of the transmitting antenna, a very weak signal will be picked up. Therefore, the antenna is said to have directional characteristics.

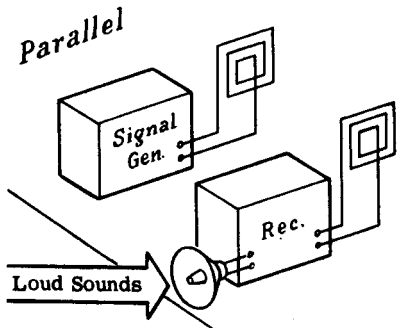

RF AMPLIFIER STAGE—An RF amplifier stage in a receiver improves the sensitivity and selectivity of the receiver. The added sensitivity is due to the amplification of the desired signal, and the added selectivity results from the use of tuned circuits which discriminate between the desired and undesired signals.

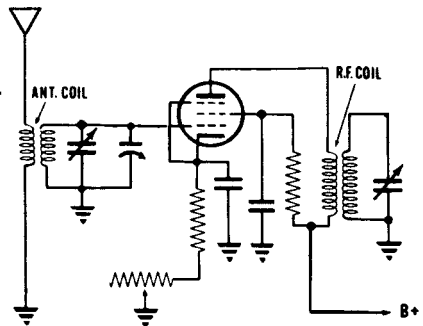

AUDIO AMPLIFIER STAGE—An audio amplifier stage in a receiver amplifies the detected audio signal. Audio stages, which precede the last stage, are voltage amplifiers whose sole function is to increase the amplitude of the audio to the level where it is large enough to drive the last stage. The last stage, called the "power stage," supplies the large current variations necessary to drive the speaker.

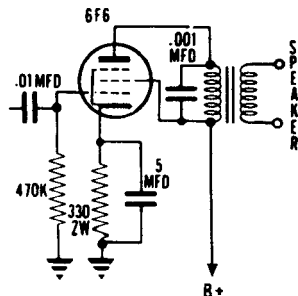

RECEIVERS

Review of Receivers (continued)

DETECTORS—The function of a detector in a receiver is to remove the audio component from a modulated RF signal so that it can be amplified by AF stages. A simple detector consists of a tuned circuit, a rectifier, and a filter. Such a detector is called a "diode detector."

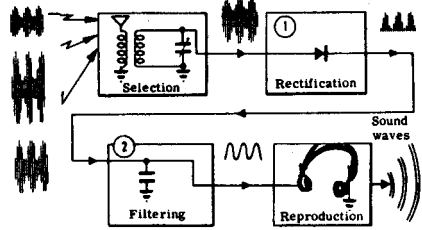

GRID-LEAK DETECTOR—This type is basically a diode detector with amplification added. The grid and cathode form the diode detector with the grid acting as the plate. The rectified signal, developed across the grid-leak resistor, is amplified in the plate circuit. This detector is more sensitive than the diode type.

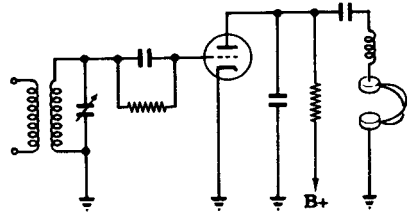

REGENERATIVE DETECTOR—This modified grid-leak type is still more sensitive. A feedback loop in the plate is coupled to the grid coil to provide regeneration, thus effectively increasing the gain of the stage.

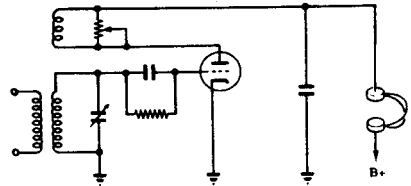
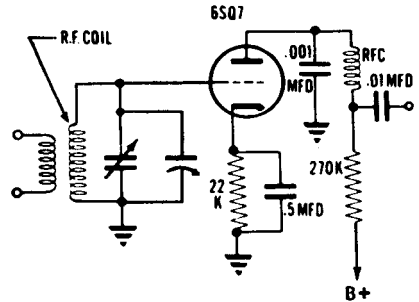

PLATE DETECTOR—This detector employs a triode or pentode, biased near cut-off. Rectification takes place in the plate circuit since the negative half of the modulated RF grid signal drives the tube into cut-off.



TRF RECEIVER—This receiver employs RF amplifiers, a detector and AF amplifiers. The tuned circuits are ganged-capacitor tuned. A shortcoming of the TRF is that since the tuned circuits are not fixed-tuned, constant sensitivity and selectivity cannot be realized over a tunable band.



TRF RECEIVER
All tank circuits gang tuned

Review (continued)

SUPERHETERODYNE RECEIVER—

The aforementioned disadvantage of the TRF is overcome in the superhet receiver, in which all desired RF signals are converted to the same fixed lower signal (called the "intermediate frequency") where the signal is amplified by fixed tuned circuits before it is detected. To accomplish this, the superhet incorporates a mixer, local oscillator and IF amplifier in addition to the usual TRF stages.

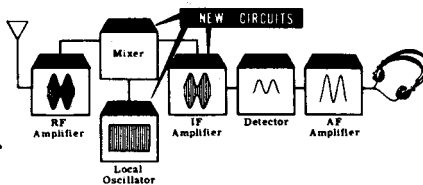

OBTAINING THE IF SIGNAL—The fixed IF signal is gotten by beating the incoming signal with the signal from a local oscillator which is always a fixed amount away from the incoming signal. This is accomplished by gang tuning the oscillator and the RF amplifier so that the difference between the RF tank resonant frequency and the oscillator tank resonant frequency is constant for all settings of the tuning dial. The oscillator tank resonant frequency is said "to track" the RF tank resonant frequency.

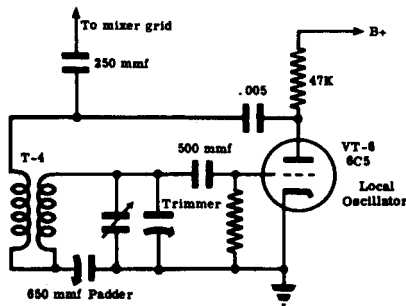

AUTOMATIC VOLUME CONTROL—The superhet receiver incorporates an AVC circuit whose function is to equalize the receiver output for both strong and weak incoming signals. It does this using a filter circuit which charges up to the DC level of the rectified RF wave. This DC voltage (negative with respect to ground) is then applied as bias to the grids of the IF, mixer and RF stages, all of which employ variable-mu tubes. In this way the bias voltage, and therefore the gain, of the stage is directly related to the intensity of the received signal.

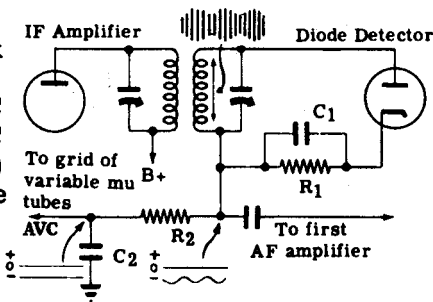

ALIGNING—When aligning a superhet the IF stages are adjusted first. Then the trimmers of the RF tuned circuits and local oscillator are adjusted at the high end of the band. The adjustment of the low frequency end of the band is made with the padder capacitor.

STEPS IN ALIGNING

- ① IF trimmers.
- ② RF tuned circuit trimmers and local oscillator trimmer at high end.
- ③ Local oscillator trimmer at low end.
 - a. Rocking in.

CONCLUSION TO BASIC ELECTRONICS

What You Have Learned

You have just completed the course in Basic Electronics. Looking back on the weeks you have spent studying these materials, what should you be able to do with the information you have now? If you can recognize the three basic electronic circuits—the rectifier, amplifier and oscillator—in a schematic diagram, if you understand how each component functions within these circuits, and what part the entire circuit plays in a piece of equipment, then you "know your stuff".

THESE ARE BASIC TO ALL ELECTRONIC EQUIPMENT

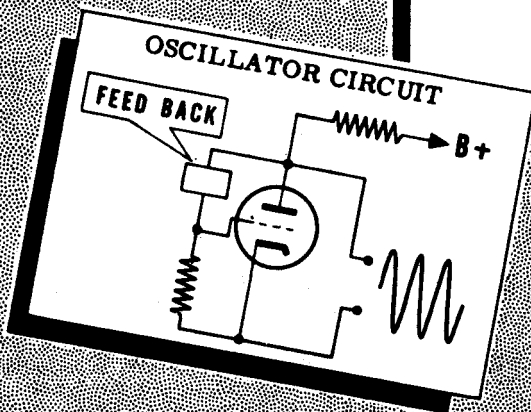
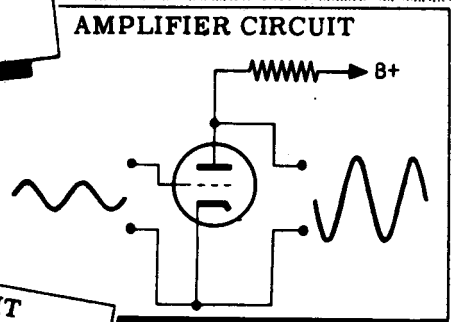
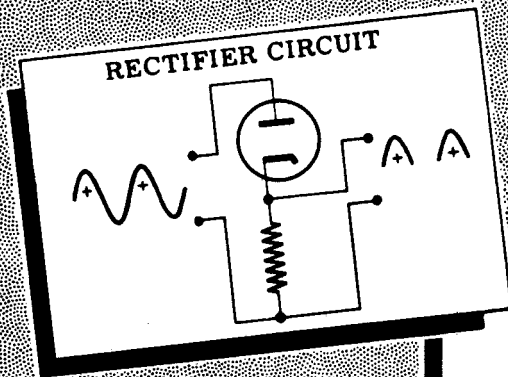

INDEX TO VOL. 5

(Note: A cumulative index covering all five volumes in this series will be found immediately following this index to Volume 5.)

- AF amplifier, tone control circuits, 5-34
 - volume control, 5-35
- AF amplifier circuits, analysis of, 5-36
- AF and RF amplifiers, comparison of, 5-37
- Alignment, what it is, 5-80
- Alignment procedure, 5-81
- Antennas, directivity as a consideration in
 - selecting and installing, 5-22
 - frequency response as a consideration in selecting and installing, 5-22
 - noise as a consideration in selecting and installing, 5-19, 5-20
 - receiver, 5-16 to 5-23
 - receiver, function of, 5-16
 - receiver, types of, 5-17, 5-18
 - signal losses as a consideration in selecting and installing, 5-21
- Audio, first stage, analysis of, 5-79
- Audio amplifiers, how they work in the superheterodyne receiver, 5-72
- Audio power amplifiers, what they do, 5-33

- Band switching, in TRF receivers, 5-28

- Capacitors, ganged, 5-29
 - trimmer, 5-30
- Coils, 5-30
- Communication, history of, 5-1 to 5-4
 - modern wireless, 5-5
- Crystal receivers, 5-11

- Demonstration, Aligning the IF Section, 5-84
 - Aligning the Mixer and Oscillator, 5-85, 5-86
- Detector, analysis of the plate detector circuit, 5-56
 - analysis of regenerative type circuit, 5-52
 - characteristics of the crystal type, 5-41
 - crystal type, 5-39
 - diode type, 5-42
 - grid-leak type, 5-43, 5-44
 - how the crystal type works, 5-40
 - how the plate type works, 5-54, 5-55
 - how the regenerative type works, 5-46 to 5-48
 - how they work in the superheterodyne receiver, 5-71
 - oscillating, 5-51
 - regenerative, 5-45
 - regenerative type as CW receiver, 5-49, 5-50
 - what they do, 5-38
- Detector stage, diode type, analysis of, 5-79

- Fidelity, in the receiver, 5-10

- IF amplifier, how it works in the superheterodyne receiver, 5-70
- IF stage, analysis of, 5-78

- Mixer stage, analysis of, 5-78
 - how it works in the superheterodyne receiver, 5-66 to 5-69

- Oscillators, beat frequency,
 - how they work, 5-75
 - local, in superheterodyne receivers, 5-63 to 5-65
 - local stage, analysis of, 5-77

- Receivers, introduction to, 5-1 to 5-15
 - recently developed uses of, 5-14, 5-15
 - the jobs they perform, 5-6, 5-7
- Review, Receivers, 5-97 to 5-99
 - Receiver Antennas, 5-23

INDEX TO VOL. 5

- The Superheterodyne Receiver, 5-87, 5-88**
- TRF Receivers — Regenerative Detector, 5-53**
- RF amplifier, analysis of, 5-32**
- RF amplifier stage, in superheterodyne receivers, 5-61, 5-62**
 - in TRF receivers, 5-25**
- RF and AF amplifiers, comparison of, 5-37**
- RF transformers, 5-26, 5-27**
- Selectivity, in the receiver, 5-9**
- Sensitivity, in the receiver, 5-8**
- Sensitivity measurements, importance of, 5-83**
 - what they are, 5-82**
- Superheterodyne receivers, 5-13, 5-57 to 5-96**
 - at high frequencies, 5-58**
 - complete schematic of, 5-76**
 - how they work, 5-59**
 - introduction to, 5-57**
 - selectivity of, 5-60**
 - troubleshooting, 5-89 to 5-96**
- TRF receivers, 5-12, 5-24 to 5-56**
 - audio amplifier stage, 5-33 to 5-37**
 - plate detector, 5-54 to 5-56**
 - regenerative detector, 5-38 to 5-53**
 - RF amplifier stage, 5-24 to 5-32**
- Troubleshooting, by signal injection, 5-90, 5-92**
 - by signal tracing, 5-90, 5-91**
 - superheterodyne circuits, 5-93, 5-94**
- Troubleshooting method, review of, 5-89**
- Vacuum tube testing, 5-95, 5-96**
- Volume control automatic, how it works in the superheterodyne receiver, 5-72 to 5-74**
 - grid bias manual type, 5-31**

CUMULATIVE INDEX

(Note: The first number in each entry identifies the volume in which the information is to be found; the second number identifies the page.)

- AC-DC half-wave rectifier, in power supplies, 1-94, 1-95
- AF amplifier, tone control circuits, 5-34
 - volume control, 5-35
- AF amplifier circuit, analysis of, 5-36
- AF and RF amplifiers, comparison of, 5-37
- Alignment, what it is, 5-80
- Alignment procedure, 5-81
- Amplification examples of, 2-1 to 2-3
- Amplifiers, 2-1 to 2-10
 - amplification in, 3-15
 - characteristics of audio power type, 2-71 to 2-73
 - characteristics of transformer-coupled type, 2-69, 2-70
 - characteristics of the two-stage type, 2-60, 2-61
 - classes of, 2-30, 2-31
 - diagram of push-pull type, 2-84
 - how the push-pull type works, 2-78 to 2-80
 - how they work, 2-17 to 2-19
 - push-pull type, 2-78 to 2-86
 - review of classes of operation, 4-8
 - single-stage, 2-55 to 2-57
 - transformer coupled, 2-67 to 2-70
 - triode type, 2-24 to 2-41
 - two-stage RC coupled type, 2-58 to 2-66
 - typical stage, 2-55
- Amplitude modulation, 4-85 to 4-99
 - percentage modulation, 4-97, 4-98
 - time base modulation pattern, 4-92
 - trapezoid figure, 4-93 to 4-96
 - what it is, 4-85
- Antennas, 4-63 to 4-79
 - basic, 4-66
 - directivity as a consideration in selecting and installing, 5-22
 - fading, 4-73
 - frequency response as a consideration in selecting and installing, 5-22
 - ground wave, 4-72
 - how they work, 4-64, 4-65
 - impedance, 4-68
 - noise as a consideration in selecting and installing, 5-19, 5-20
 - purpose of, 4-63
 - radiation pattern, 4-70
 - radiation resistance, 4-67
 - receiver, 5-16 to 5-23
 - receiver, function of, 5-16
 - receiver, types of, 5-17, 5-18
 - signal losses as a consideration in selecting and installing, 5-21
 - sky wave, 4-72
 - space wave, 4-73
 - tuning, 4-69
 - wave propagation, 4-71
- Armstrong oscillators, 3-55 to 3-61
 - advantages of grid leak bias in, 3-60
 - advantages of push-pull type, 2-85
 - frequency instability in, 3-61
 - grid leak bias in, 3-56
 - how oscillations are maintained in, 3-57, 3-58
- Audio, first stage, analysis of, 5-79
- Audio amplifiers, how they work in the superheterodyne receiver, 5-72
- Audio power amplifiers, what they do, 5-33
- Band pass, 3-37
- Band switching, in TRF receivers, 5-28
- Beam power tube, 2-50, 2-51
 - construction of a typical tube, 2-51
- Bias, B+ power supply, 2-34
 - battery, 2-32
 - cathode, 2-35
 - grid voltage, 2-24 to 2-26
 - power supply, 2-33
- Bridge rectifier circuits, 1-49, 1-50
- Capacitors, ganged, 5-29
 - how they are connected to the RF amplifier tube, 3-30
 - trimmer, 5-30
 - tuning, 3-25
- Cathode bypass capacitor, 2-38 to 2-40
- Cathode resistor, 2-36, 2-37
- Class C amplifiers, 4-8 to 4-15
 - combination bias, 4-14
 - fixed bias, 4-11
 - self-bias, 4-12, 4-13
 - tuned, 4-9, 4-10
- Coils, 5-30
 - how they are connected to the RF amplifier tube, 3-30
 - tuning, 3-26
- Colpitts oscillators, 3-64
- Communication, history of, 5-1 to 5-4
 - modern wireless, 5-5
- Compensating networks, high-frequency compensation, 3-5
 - low-frequency compensation, 3-6
- Coupling, amplifier stages, 5-59
 - transformer, 2-67, 2-68
- Coupling circuits, 4-40
 - tuned, 4-41
- Crystals, as resonators, 3-69
- Crystal oscillators, 3-68 to 3-73
 - analysis of, 3-72
 - introduction to, 3-68
 - tuning in, 3-71
- Crystal oscillator circuits, 3-70
- Crystal receivers, 5-11
- Current flow, in full-wave rectifier circuits, 1-48
 - in half-wave rectifier circuits, 1-43
- CW transmission, 4-80 to 4-84
 - advantage of, 4-80
 - blocked-grid keying, 4-83
 - cathode keying, 4-81, 4-82
 - keyer tube circuits, 4-84
- Decoupling filters, 2-56, 2-57
- Degeneration, 3-7 to 3-9
- Demonstration, Aligning the IF Section, 5-84

CUMULATIVE INDEX

- Aligning the Mixer and Oscillator, 5-85, 5-86
- Current Distribution Along an Antenna, 4-75
- Radiation Pattern of an Antenna, 4-76 to 4-78
- Transmission Lines, 4-57 to 4-61
- Detectors, analysis of the plate detector circuit, 5-56
 - analysis of the regenerative type circuit, 5-52
 - characteristics of the crystal type, 5-41
 - crystal type, 5-39
 - diode type, 5-42
 - grid-leak type, 5-43, 5-44
 - how the crystal type works, 5-40
 - how the plate type works, 5-54, 5-55
 - how the regenerative type works, 5-46 to 5-48
 - how they work in the superheterodyne receiver, 5-71
 - oscillating, 5-51
 - regenerative, 5-45
 - regenerative type as CW receiver, 5-49, 5-50
 - what they do, 5-38
- Detector stage, diode type, analysis of, 5-79
- Diodes, characteristics of, 1-109 to 1-112
 - current flow in, 1-28, 1-29
 - gas-filled, 1-35
 - how current is controlled in, 1-112
 - how they work, 1-25
 - in transformer type circuits, 1-40, 1-41
 - vacuum-filled in power supplies, 1-36
- Dynamotors, 1-104
- Earphones, 2-93
- Electron-coupled oscillators, 3-74 to 3-77
 - analysis of, 3-77
 - introduction to, 3-74
- Electron-coupled oscillator circuits, 3-75, 3-76
- Electronics, meaning of, 1-1
- Electronic equipment, 1-2
 - parts used in, 1-3
- Fidelity, in the receiver, 5-10
- Filters, improving operation of, 1-64, 1-65
 - power supplies, 1-12
- Filter capacitors (condensers), 1-60 to 1-63
 - electrolytic, 1-61 to 1-63
 - electrolytic dry, 1-63
 - electrolytic wet, 1-62
 - paper, construction of, 1-60
 - paper, high-voltage, 1-60
- Filter chokes, 1-69
- Filter circuits, 1-52 to 1-80
 - capacitors in, 1-57 to 1-59
 - capacitor input, filter circuit, single-section, 1-70, 1-72
 - choke input, filter circuit, single-section, 1-70, 1-71
 - in power supplies, 1-53
 - parallel resonant, 1-73
 - RC, faults of, 1-66, 1-67
 - series-resonant, 1-73
 - two-section, 1-73
 - using choke instead of resistor, 1-68
- Frequency, 4-43
 - Frequency doubling, 4-36
 - Frequency measurement, using standing waves, 4-53
 - Frequency multiplication, purpose of, 4-34
 - Frequency multipliers, 4-34 to 4-38
 - final power amplifier, 4-35
 - tuning indications, 4-38
 - Frequency response, 2-62 to 2-64
 - curve, 2-65
 - improving, 3-7 to 3-9
 - Frequency spectrum, 4-74
 - Frequency tripling, 4-37
- Gain, increase of, 2-58
- Hartley oscillators, 3-62, 3-63
 - how oscillations are maintained, 3-63
- High frequency oscillators, 3-82
 - tuned lines in, 3-83
- IF amplifier, how it works in the superheterodyne receiver, 5-70
- IF stage, analysis of, 5-78
- Impedance matching, 2-76, 2-77
- Input filter capacitor, 1-74
- Inverters, 1-105
- Klystron tubes, 3-85
- LC circuits, parallel, 3-21, 3-22
 - series, 3-20
- Loudspeakers, dynamic type, 2-94
- Microphones, 2-88 to 2-92
 - carbon, 2-89
 - characteristics of, 2-88
 - crystal, 2-90
 - dynamic type, 2-91
 - ribbon or velocity type, 2-92
- Mixer stage, analysis of, 5-78
 - how it works in the superheterodyne receiver, 5-66 to 5-69
- Modulation, grid, 4-90
 - how it is accomplished, 4-87
 - other methods of, 4-91
 - plate, 4-89
- Modulators, 4-88
- Motor generators, 1-104
- Oscillations, frequency of, 3-59
 - what they are, 3-45 to 3-47
- Oscillators, 3-41 to 3-89
 - beat frequency, how they work, 5-75
 - different grounding points in, 3-80
 - electronic, 3-48 to 3-52
 - feedback circuits in, 3-53
 - frequency stability of, 3-54
 - introduction to, 3-43 to 3-54
 - local, in superheterodyne receivers, 5-63 to 5-65
 - local stage, analysis of, 5-77
 - other circuits, 3-81

CUMULATIVE INDEX

- RF ground potential, 3-79
- series feed, 3-78
- shunt feed, 3-78
- what they do, 3-44
- why they are studied, 3-43
- Output transformers, 2-74 to 2-77
 - job of, 2-74, 2-75
- Pentodes, 2-47 to 2-49, 2-52, 2-53
 - construction of a typical tube, 2-49
 - how they work, 2-48
 - remote cut-off, 3-32, 3-33
 - summary of operation of, 2-52, 2-53
 - why they are used in RF amplifiers, 3-28, 3-29
- Phase inverters, 2-81 to 2-83
 - another type of, 2-83
 - how they work, 2-82
- Power line filter capacitor circuits, 1-43
- Power supplies, circuits in, 1-52
 - dry metal rectifier, 1-97
 - for DC voltage sources, 1-99
 - general types, 1-93
 - importance of, 1-7
 - need for other types, 1-92
 - transformer type, 1-39
 - transformerless, 1-94 to 1-98
 - transformerless and chokeless, 1-98
 - voltage doubler, 1-96
 - what they do, 1-8
 - why there are different types, 1-14 to 1-16
- Receivers, introduction to, 5-1 to 5-15
 - recently developed uses of, 5-14, 5-15
 - the jobs they perform, 5-6, 5-7
- Rectifiers, changing AC to DC in half-wave
 - dry metal type, 1-17
 - copper oxide, 1-18
 - circuits in dry metal half-wave type, 1-21
 - description of half-wave dry metal type, 1-18 to 1-20
 - dry metal half-wave, 1-17 to 1-22
 - full-wave, 1-45 to 1-51
 - full-wave, how they work, 1-46
 - gas-filled diodes, 1-35 to 1-37
 - parallel connection of elements in dry metal type, 1-19
 - power supplies, 1-10, 1-11
 - selenium, 1-18, 1-20
 - series stacking of elements in dry metal type, 1-19
 - transformer type, half-wave, 1-39 to 1-44
 - vacuum tubes, 1-23
 - vacuum tube half-wave type, 1-23 to 1-38
- Rectifier circuits, half-wave vacuum tube, 1-33
- Rectifier output, AC and DC components in, 1-55, 1-56
 - characteristics of, 1-54
 - filtering half- and full-wave, 1-74
- Rectifier tubes, 1-30, 1-31
 - cathode type, 1-31
 - diodes, 1-30, 1-31
 - directly heated, 1-32
 - full-wave, 1-47
 - indirectly heated, 1-32
 - plates connected together, 1-32
 - plates connected separately, 1-32
- Resistors, bleeder, 1-75 to 1-77
- Resonators, cavity type at ultra-high frequencies, 3-84
- Resonant circuits, how stations are selected, 3-23
- Review, A Single-Stage RF Amplifier, 3-34
 - A Three-Stage Transmitter, 4-33
 - Amplitude Modulation, 4-99
 - Antennas, 4-79
 - Audio Amplifiers, 2-96 to 2-98
 - Class C Amplifiers, 4-15
 - Diode Characteristics, 1-111
 - Filter Circuits, 1-78 to 1-80
 - Full-Wave Rectifier Circuit, 1-51
 - Half-Wave Rectifiers — Dry Metal Type, 1-22
 - Half-Wave Rectifiers — Transformer Type, 1-44
 - Half-Wave Rectifiers — Vacuum Tube Type, 1-38
 - Microphones, Earphones and Loudspeakers, 2-95
 - Miscellaneous Oscillators, 3-86, 3-87
 - Oscillators, 3-88, 3-89
 - Other Types of Power Supply Circuits, 1-106 to 1-108
 - Power Supplies, 1-113 to 1-115
 - Receivers, 5-97 to 5-99
 - Receiver Antennas, 5-23
 - The Armstrong and Hartley Oscillators, 3-65
 - The Push-Pull Amplifier, 2-86
 - The Superheterodyne Receiver, 5-87, 5-88
 - The Tetrode and the Pentode, 2-54
 - The Triode, 2-23
 - The Triode Amplifier, 2-41
 - The Tuned-Plate Tuned-Grid and Crystal Oscillators, 3-73
 - The Two-Stage RC Coupled Amplifier, 2-66
 - The Two-Stage RF Amplifier, 3-39
 - Transmission Lines, 4-62
 - Transmitters, 4-100 to 4-102
 - TRF Receivers — Regenerative Detector, 5-53
 - Tuned Circuits, 3-27
 - Video Amplifiers, 3-10, 3-11
 - Voltage Regulator Circuits, 1-91
- RF amplifiers, 3-13 to 3-39
 - analysis of, 5-32
 - introduction to, 3-15 to 3-18
 - two-stage, 3-35 to 3-39
 - single-stage, 3-28 to 3-34
 - what they do, 3-16, 3-17
- RF amplifier circuit, development of, 3-31
- RF amplifier stage, in superheterodyne receivers, 5-61, 5-62
 - in TRF receivers, 5-25
- RF and AF amplifiers, comparison of, 5-37
- RF stages, how they are coupled, 3-38
 - why more than one is used, 3-35, 3-36
- RF transformers, in TRF receivers, 5-26, 5-27

CUMULATIVE INDEX

- Rotary converters, 1-105
- Selectivity, 3-37
 - and "Q", 3-24
 - in the receiver, 5-9
- Sensitivity, in the receiver, 5-8
- Sensitivity measurements, importance of, 5-83
 - what they are, 5-82
- Sidebands, 4-86
- Sound, principles of, 2-87
- Square waves, distortion of, 3-3, 3-4
- Superheterodyne receivers, 5-13, 5-57 to 5-96
 - at high frequencies, 5-58
 - complete schematic of, 5-76
 - how they work, 5-59
 - introduction to, 5-57
 - selectivity of, 5-60
 - troubleshooting, 5-89 to 5-96
- Tetrodes, 2-42 to 2-46
 - eliminating effects of secondary emission, 2-47
 - normal operation of, 2-46
 - screen grid, 2-43
 - secondary emission, 2-44
 - static characteristics of, 2-45
 - why they were developed, 2-42
- Three-stage transmitters, 4-16 to 4-33
 - complete diagram of, 4-21
 - intermediate power amplifier, 4-18
 - neutralization, 4-27 to 4-29
 - neutralizing procedures, 4-30, 4-31
 - oscillators, 4-17
 - parasitic oscillations, 4-32
 - power amplifier, 4-19
 - purpose of tuning, 4-22
 - three basic circuits, 4-16
 - transmitting tube filament circuit, 4-20
 - tuning methods, 4-23 to 4-26
- Transformers, power supplies, 1-9
- Transformer type circuit, diagram of, 1-42
 - operation of, 1-43
- Transmission, AM, 4-6
 - FM, 4-6
 - keyed, 4-5
 - voice, 4-6
- Transmission lines, 4-39 to 4-62
 - characteristic impedance of, 4-45
 - equivalent circuit of, 4-44
 - input impedance of a line, 4-50
 - input impedance of an open-circuited line, 4-52
 - input impedance of a short-circuited line, 4-51
 - line termination in characteristic impedance, 4-46
 - nonresonant and resonant lines, 4-47
 - open and shorted, 4-49
 - standing waves on rope, 4-48
 - transferring electrical energy, 4-42
 - types of, 4-56
- Transmission line principles, 4-54, 4-55
- Transmitters, a simple type, 4-2 to 4-4
 - overall, 4-39
 - what they are, 4-1 to 4-7
- TRF receivers, 5-12, 5-24 to 5-56
 - audio amplifier stage, 5-33 to 5-37
 - plate detector, 5-54 to 5-56
 - regenerative detector, 5-38 to 5-53
 - RF amplifier stage, 5-24 to 5-32
- Triodes, 2-11 to 2-23
 - control grid in, 2-14, 2-15
 - construction of typical tube, 2-12
 - how they work, 2-13
 - similarity to the diode, 2-16
- Triode amplifiers, why proper bias is necessary, 2-27 to 2-29
- Triode tube characteristics, amplification factor, 2-20
 - plate resistance, 2-21
 - transconductance, 2-22
- Troubleshooting, by signal injection, 5-90, 5-92
 - by signal tracing, 5-90, 5-91
 - superheterodyne circuits, 5-93, 5-94
- Troubleshooting method, review of, 5-89
- Tuned circuits, what they are, 3-19
- Tuned-plate tuned-grid oscillators, 3-66, 3-67
 - feedback in, 3-67
 - introduction to, 3-66
- Vacuum tubes, amplification, 2-11
 - circuit wiring, 1-34
 - discovery of diode, 1-24
 - electron emission, 1-26, 1-27
 - factors common to all, 1-110
 - how they were developed, 2-8, 2-9
 - jobs of, 1-109
 - methods of representation in diagrams, 1-34
 - sockets, 1-31
 - types of, 2-6, 2-7
 - what they can do, 2-4, 2-5
- Vacuum tube testing, 5-95, 5-96
- Vibrators, 1-100 to 1-103
 - synchronous, 1-103
- Video amplifiers, 3-1 to 3-11
 - introduction to, 3-1, 3-2
- Voltage regulators, 1-81, 1-82
- Voltage regulation, when load current varies, 1-87, 1-88
 - when power supply voltage varies, 1-89, 1-90
- Voltage regulators, power supply, 1-13
- Voltage regulator circuits, 1-81 to 1-91
- Voltage regulator tube, 1-83, 1-84
- Voltage regulator tube circuit, 1-85, 1-86
- Volume control, automatic, how it works in the superheterodyne receiver, 5-72 to 5-74
 - grid bias manual type, 5-31
- Wavelength, 4-43

HOW THIS OUTSTANDING COURSE WAS DEVELOPED:

In the Spring of 1951, the Chief of Naval Personnel, seeking a streamlined, more efficient method of presenting Basic Electricity and Basic Electronics to the thousands of students in Navy speciality schools, called on the graphiological engineering firm of Van Valkenburgh, Nooger & Neville, Inc., to prepare such a course. This organization, specialists in the production of complete "packaged training programs," had broad experience serving industrial organizations requiring mass-training techniques.

These were the aims of the proposed project, which came to be known as the Common-Core program: to make Basic Electricity and Basic Electronics completely understandable to every Navy student, regardless of previous education; to enable the Navy to turn out trained technicians at a faster rate (cutting the *cost* of training as well as the time required) without sacrificing subject matter.

The firm met with electronics experts, educators, officers-in-charge of various Navy schools and, with the Chief of Naval Personnel, created a dynamic new training course . . . completely up-to-date . . . with heavy emphasis on the visual approach.

First established in selected Navy schools in April, 1953, the training course comprising Basic Electricity and Basic Electronics was such a tremendous success that it is now the *backbone* of the Navy's *current* electricity and electronics training program!*

The course presents one fundamental topic at a time, taken up in the order of need, rendered absolutely understandable, and hammered home by the use of clear, cartoon-type illustrations. These illustrations are the most effective ever presented. *Every page has at least one such illustration—every page covers one complete idea!* An imaginary instructor stands figuratively at the reader's elbow, doing demonstrations that make it easier to understand each subject presented in the course.

Now, for the first time, Basic Electricity and Basic Electronics have been released by the Navy for civilian use. While the course was *originally* designed for the Navy, the concepts are so broad, the presentation so clear—*without* reference to specific Navy equipment—that it is ideal for use by schools, industrial training programs, or home study. *There is no finer training material!*

"Basic Electronics" consists of *five* volumes, as follows: *Vol. 1—Introduction to Electronics, Diode Vacuum Tubes, Dry Metal Rectifiers, What a Power Supply Is, Filters, Voltage Regulators. Vol. 2—Introduction to Amplifiers, The Triode Tube, Tetrodes & Pentodes, Audio Voltage & Power Amplifiers. Vol. 3—Video Amplifiers, RF Amplifiers, Oscillators. Vol. 4—Transmitters, Transmission Lines & Antennas, CW Transmission & Amplitude Modulation. Vol. 5—Receiver Antennas, Detectors & Mixers, TRF Receivers, Superheterodyne Receivers.*

*"Basic Electricity," the first portion of this course, is available as a separate series of volumes.

JOHN F. RIDER PUBLISHER, INC., 116 WEST 14th ST., N. Y. 11, N. Y.