

ELECTRONIC TECHNOLOGY SERIES

CRYSTAL OSCILLATORS

a **RIDER** **publication**

\$1.25

Crystal Oscillators

Edited by

Alexander Schure, Ph. D., Ed.D.



JOHN F. RIDER PUBLISHER, INC.
480 Canal Street • New York 13, N.Y.

Copyright 1955 by

JOHN F. RIDER PUBLISHER, INC.

All rights reserved. This book or parts thereof may not be reproduced in any form or in any language without permission of the publisher.

FIRST EDITION

Library of Congress Catalog Card No. 55-12397

Printed in the United States of America

PREFACE

The study of oscillators is an integral part of every curriculum in electronics. One of the subdivisions is the study of crystals and crystal oscillators. In spite of its importance and complexity, the topic is rarely given extended treatment in textbooks. The value of the topic stems from constant use of the crystal oscillator in amateur, commercial, and military applications. The concepts necessary to the study of this important subject have been selected for this book.

Every effort has been made to make this work as comprehensive as possible. Included are descriptions of the nature of the piezo-electric field; of the characteristics of crystal elements and mounting methods; of the equivalent circuit characteristics of crystal units; and analyses of basic piezo-electric oscillator principles and circuit parameters.

The organization and treatment used in the book have been arranged to help the student follow each important item. The analysis of each of the topics presented is given in sufficient detail to assist the advanced student or practicing engineer to review the fundamental constants and basic applications to his advantage. With this idea in mind, all of the basic types of crystal oscillators have been treated in considerable detail.

Crystals and crystal oscillators play an important role in thousands of circuits developed and utilized each year. It would obviously be impossible to list and catalog all of the possible applications in a work of this size. The illustrative circuits shown herein were chosen for their simplicity and relative importance.

Acknowledgement is hereby made to WADC Technical Report 54-248, Handbook of Piezoelectric Crystals for Radio Equipment Designers (Wright Air Development Center), by John P. Buchanan. This report proved of immeasurable assistance in the derivation of the numerical data and some of the circuitry included in this manuscript.

Grateful acknowledgement is also made to the staff of The New York Technical Institute for its preparation of the manuscript for this booklet.

New York, N. Y.
November, 1955

A. S.

CONTENTS

<i>Chapter</i>		<i>Page</i>
1	Review of Oscillation Principles	1
2	Basic Quartz Crystal Oscillator	6
3	Crystal Techniques	21
4	Popular Crystal Oscillator Circuits	38
5	Harmonic and Overtone Crystal Oscillator Circuits	47

Chapter 1

REVIEW OF OSCILLATION PRINCIPLES

1. The Meaning of Oscillation

The oscillator is almost as old as radio itself. In every generation since Hertz transmitted electrical energy across a room, amateur experimenters and professional engineers have labored to improve oscillatory circuits along various lines toward the end of meeting the increasingly rigorous demands which the passing years impose.

Oscillation is a process in which an alternating voltage is produced as the result of the conversion of energy from one form to another through the use of some reciprocating agency. For example, the vibrator in an automobile radio is a mechanical oscillator that converts the d-c power of the car battery into higher a-c voltages and currents with the aid of a power transformer.

When used in association with vacuum tubes and other electronic gear, the word oscillation refers to the action in a generator of a-c power in the form of pulsating electron streams. The a-c power is generated in association with resonant circuits composed of inductors and capacitors, or time constant circuits made up of resistive and capacitive components. In this book we shall be concerned only with *L-C* circuit oscillations in the radio-frequency spectrum; *R-C* and low-frequency oscillators are covered elsewhere in this Review Series.

2. Applications of Oscillators

Virtually every phase of electronic industrial control and plant operation, communication, electronic warfare, radio aids to navigation, and many fields of research rely upon oscillators in one form or another. A general list of applications would be endless.

The discussion of crystal oscillators to follow will point to uses of this device particularly in communications, inasmuch as it is this field in which crystal control finds its natural application.

3. Oscillator Performance Requirements

Radio operators and others who are directly associated with the performance of radio transmitters have found by experience that certain performance features are required in the transmitter as a whole to ensure optimum operation. The most important features are: frequency stability, power output, simplicity of operation, ruggedness and reliability, and continuous frequency coverage. The first two features not only are a matter of convenience, but must meet certain legal requirements of law and of the Federal Communications Commission (FCC).

Because the oscillator generates the r-f carrier for the whole transmitter, it also fully controls the frequency stability of the transmitter. In the other transmitter features listed above, the oscillator must harmonize with the design of the complete transmitter. Thus all the above features are important in oscillator design. Let us examine each feature individually.

Frequency Stability. This is by far the most important consideration in the design of oscillators for communication equipment. It is the ability of an oscillator to maintain the same frequency of oscillation under conditions of changing load, changing d-c supply voltage, changing temperature, changing barometric pressure, vibration and mechanical shock, external capacitance and inductance effects, and high humidity.

Power Output. An oscillator with high power output lends itself to the design of a simpler transmitter because it reduces the need for many cascaded radio-frequency amplifier stages. Thus, an important goal of the oscillator designer and builder is as much

power output as possible without adversely affecting frequency stability. However, the two cannot usually be increased together. Power output is normally sacrificed in favor of frequency stability.

Simplicity of Operation. Oscillators having a variety of frequency ranges may be designed with one, two, or even three different adjustments. Hence one of the criteria for judging the value of an oscillator is the number of desirable operating features for a given complexity of the adjustments.

Ruggedness and Reliability. These characteristics speak for themselves and are important factors in the choice of an oscillator for a given job. Although construction methods contribute more to achieving good performance in these respects, circuit design also makes an appreciable difference in many instances.

Continuous Frequency Coverage. The ideal oscillator would offer the feature of continuous tuning over a required band of frequencies. As a further requisite, the output power should remain constant throughout the tuning range. Few self-excited oscillators fulfill the latter requirements, but many come very close to it; in addition, practically all of them do permit continuous frequency coverage.

4. Self-Excited L-C Oscillator Characteristics

By virtue of its ability to *amplify*, a vacuum tube (or a transistor) may be used to produce sustained oscillations in an L-C circuit (usually referred to as a *tank circuit*). To set up the conditions necessary for sustained oscillation, a tank circuit must be shock-excited into oscillation by a *change* in the current flowing through it; the oscillatory voltage thus developed must then be amplified by the tube, and a portion of the amplified power fed back to the oscillatory tank circuit to make up for the losses that occur there due to resistance, grid current flow, radiation, and loading. Because these losses may be made very small, particularly at the lower radio frequencies, a relatively small amount of feedback is all that is necessary, provided that it is phased properly to reinforce the oscillations.

The tube output may be coupled back to its input circuit by means of an inductive or capacitive network. In either case, when

the coupling is correctly adjusted, the feedback phase and amplitude cause sustained oscillations at a frequency approximately determined by the equation:

$$f = \frac{1}{2\pi\sqrt{LC}}$$

$f =$ cps
 $L =$ henries
 $C =$ farads

In Fig. 1 (A) is an inductive-feedback oscillator and (B) a capacitive type. In (A) the mutual inductance M is responsible for the feedback from plate winding $L2$ to grid winding $L1$. In (B) the component labeled $A-B$ is the reactance which is common to both plate and grid circuits and which accounts for the feedback.

Oscillators such as these are capable of very large power output when used with appropriately large vacuum tubes; in both cases two initial adjustments are required: in the inductively coupled type (1A), the setting of C determines the frequency with a given tank inductance, L . The coupling between $L1$ and $L2$ influences the efficiency of operation; the adjustments on the capacitive feedback oscillator (1B) involve the proper ratio between C_g and C_p to provide the grid with sufficient excitation for maintaining oscillations and further adjustment of both these capacitors to establish the desired frequency.

Self-excited oscillators must be of special design to avoid poor frequency stability at the radio frequencies. They are subject to line voltage variations, changes in loading, atmospheric conditions, and mechanical shock; under each of these circumstances the frequency and output amplitude tend to fluctuate unless extreme

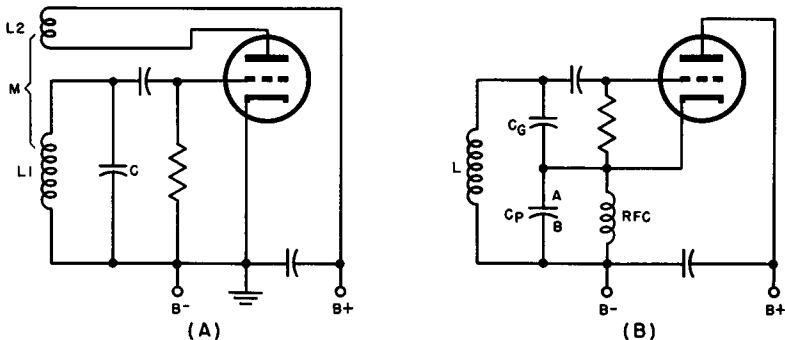

Fig. 1. Circuits illustrating inductive feedback (A) and capacitive feedback (B).

care is taken in the design. Thus, except when elaborate design measures for stability are taken, these oscillators are not suitable for radio transmitters, for which the FCC has set up small frequency tolerances.

The crystal-controlled oscillator answers the demand for simplified design with extraordinarily high frequency stability; it is rugged, easy to operate, and in most cases thoroughly reliable. Crystal oscillators cannot, however, be made to yield power output comparable with that of self-excited oscillators using large tubes and must, therefore, be followed by one or more radio-frequency amplifiers depending upon the power output requirements. This is not an important factor, however, because adequately stable self-excited oscillators must operate at low power anyway. Nor does the crystal oscillator lend itself to continuous frequency coverage, although crystal switching is now a perfected art and does enable the operator to choose one of several frequencies within the same band without retuning the entire transmitter.

5. Review Questions

1. Give six criteria for evaluating the performance of an oscillator.
2. What is meant by "frequency stability" in respect to an oscillator?
3. What is a "self-excited" oscillator?
4. Give the equation for calculating the frequency of oscillation.
5. What would be the frequency of oscillation of a theoretically resistance-free tank circuit whose inductance is $70 \mu\text{henries}$ and whose capacitance is $200 \mu\mu\text{F}$?
6. Draw a diagram of an inductive feedback oscillator.
7. Draw a diagram of a capacitive type feedback oscillator. Modify this diagram and that of question 6 to change these circuits to crystal-oscillator circuits.
8. List the characteristics governing adjustment of the oscillators whose circuits are drawn in answer to questions 6 and 7.
9. Enumerate two disadvantages of the self-excited type of oscillator.
10. List the desirable features and the disadvantages of a crystal controlled oscillator.

Chapter 2

BASIC QUARTZ CRYSTAL OSCILLATOR

6. Piezo-Electric Effect

The remarkable property of certain crystalline substances, notably quartz, in exercising control over the frequency of an oscillator arises from a relationship between *electrical stress* and *mechanical movement* that exists in such crystals. When a thin, flat section is cut from a "mother stone" (Fig. 2) along certain dimensions to be discussed later, the *plate* thus obtained actually vibrates at a high frequency rate when properly excited electrically. The phenomenon of the appearance of electrical charges on the faces of the plate, resulting from physical compression or distortion is called the *piezo-electric effect*.

Piezo-electricity is common to crystals such as Rochelle salts, tourmaline, and quartz. Any one of these may be used for frequency control. Quartz, however, has completely eclipsed the others in practical work. It does not fracture as easily as Rochelle salts while under stress nor is it affected by moisture, high temperature, and high humidity as are Rochelle salt crystals. Quartz is much more sensitive electrically and less costly than tourmaline. A crystal of Rochelle salts is capable of producing much greater piezo-electric voltages than quartz and for this reason is utilized in the manufacture of crystal microphones, in which the mechanical forces are not as great as they are in crystal oscillators. Tourmaline, on the other

Fig. 2. Quartz crystal, from which oscillator plates are cut.

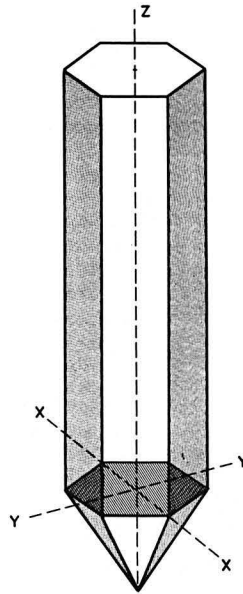

hand, is mechanically stronger than quartz and does not have to be ground as thin as quartz for a given oscillation frequency. However, because of its insensitivity, it is used only at very high radio frequencies where a fundamental quartz crystal would be impractical. The popularity of quartz may also be attributed to its low cost and its ready availability.

7. Crystal Characteristics

Quartz occurs naturally in the form of crystals that vary in size and shape, but the ones chosen for their piezo-electric properties are generally hexagonal in cross-section, having six side faces as shown in Fig. 2. Crystals of this form are usually capped by hexagonal pyramids at one or both ends, the pyramid having six *cap faces*.

To differentiate between the various directions within the crystal, lines may be drawn as shown in the figure, joining different important points. These lines, called *axes*, are conventionally labeled as shown in the figure.

The X axis joins two *points* at opposing corners of the hexagon. There are three such axes although only one is shown in the figure for the sake of clarity. The lines joining the remaining two pairs of corners are called X' and X'' . The X axes are termed the *electrical axes* because the greatest electrical sensitivity lies along these lines.

The Y axis joins two *faces* at opposite sides of the hexagon, intersecting the face planes at right angles. Again, since there are six faces, there are three Y axes (Y , Y' , and Y'') called the *mechanical axes*.

There is only one Z axis. Referred to as the *optical axis*, it passes longitudinally through the center of the mother stone and intersects all the X and Y axes perpendicularly.

The process of making a complete crystal unit from a mother stone involves proper orientation of the plate with respect to the three axes, cutting, grinding to the thickness needed to establish a desired frequency, and mounting in a suitable holder.

8. Modes of Vibration

When an alternating voltage is applied across a quartz crystal so that there is a component of electric stress (electrostatic field) along one of the X axes, mechanical strains or dimensional changes occur along the Y axis that is perpendicular to the X axis in use. When the electric stress alternates, the variations in size or shape of the plate likewise change so that the crystal vibrates mechanically. At a certain frequency of vibration, determined by the dimensions of the plate, the type of cut, the kind of holder or mounting, and other minor factors, the plate comes into *mechanical resonance* like a pendulum that is periodically prodded at exactly the right instant. At resonance, the crystal vibration may become very great in amplitude—great enough, in fact, to cause a fracture if the vibration is uncontrolled.

Even a simple thing like a vibrating violin string may oscillate in different *modes*; it may, for instance, move up and down as a whole (Fig. 3A), in two parts (Fig. 3B), in three parts (Fig. 3C), or in other configurations. When vibrating as a whole, the musical note is the lowest in pitch that this particular string can produce

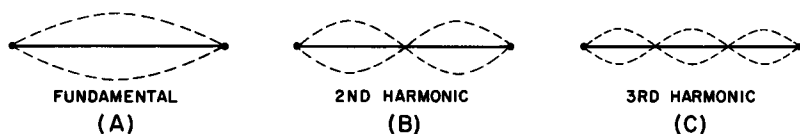

Fig. 3. Modes of vibration of a violin string.

and is called the *fundamental tone*. The two-part motion at twice the frequency of the fundamental tone is the *first overtone* or *second harmonic*; the vibration in three parts, having a frequency three times that of the fundamental, is the *second overtone* or *third harmonic*. In the interests of consistency, reference will be made only to harmonics in this discussion; it should be noted that this is appreciably simpler to interpret because the harmonic number is equal to the multiple of the fundamental frequency. That is, harmonic number = number of times fundamental is multiplied.

Depending upon the orientation of the crystal cut, a given plate usually vibrates in one particular mode, but various modes are possible under different conditions of cut, grinding, mounting, and excitation.

Flexure Mode (Fig. 4A). This kind of vibration is similar to that of a vibrating string producing its fundamental tone. When oscillating in this mode, a crystal produces an a-c voltage at its lowest characteristic frequency.

Shear Mode (Fig. 4B and 4C). As the name implies, this mode of vibration tends to shear the crystal along either its thickness (Fig. 4B) or along the face (Fig. 4C). The resulting distortion may be visualized as one in which the rectangular cross-section is altered to a regular parallelogram whose corner angles vary from some acute angle through 90 degrees to a corresponding obtuse angle as shown in the figures. This mode is employed chiefly at high frequencies because, in this portion of the spectrum, quartz vibrating in this mode can be given good temperature-frequency stability (low temperature coefficient).

Longitudinal Mode. This is sometimes called the *compression-al mode*. As Fig. 4D shows, the vibration occurs in such a manner as to periodically elongate and simultaneously reduce the thickness of the plate. This is a piston-like action which, in addition to its

use in frequency control functions, is now being applied to the design of ultrasonic crystal transducers. This mode of oscillation is especially useful in the frequency range between the flexure mode (very low frequencies) and the shear mode (high frequencies).

Torsional Mode. This mode is characterized by a twisting motion around the long axis of the plate. It is of historical interest only, having been used for very low frequencies in the early days of crystal control. It is no longer used in this country.

Activating potentials are normally applied to crystals at two points, as shown in Fig. 4E. In certain applications, however, where a low-frequency flexure mode is to be used, a special mounting, in which potentials are applied at four points as shown in Fig. 4F, is necessary.

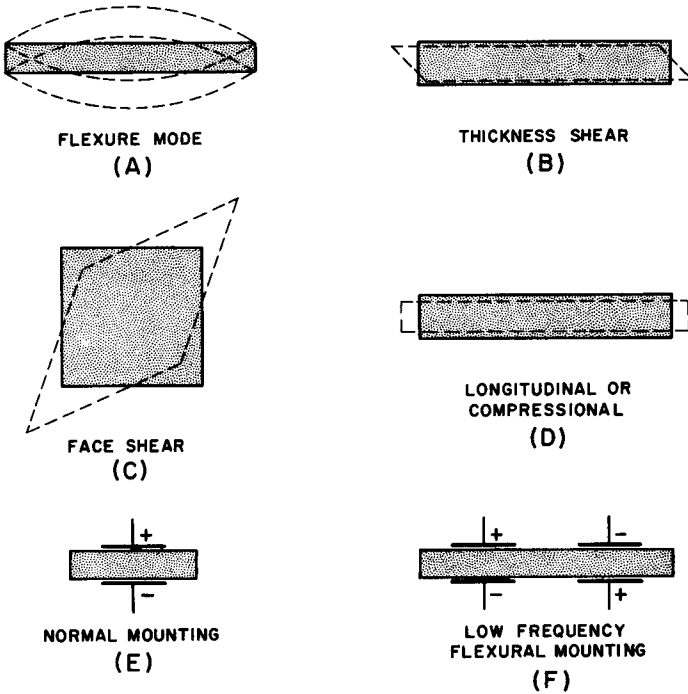

Fig. 4. Modes and mountings for oscillating crystals.

9. Fundamental Crystal Oscillator Circuit (Basic Miller Oscillator)

A triode amplifier with a resonant circuit in its output as well as its input circuit constitutes the standard tuned-plate, tuned-grid (TPTG) oscillator (Fig. 5). Positive feedback from the plate to the grid occurs through the grid-to-plate capacitances of the triode. Substituting a quartz crystal for the $L1-C1-C_p$ combination produces sustained oscillations if the $L2-C2$ tuning circuit is resonated to a frequency at or very close to the natural frequency of the crystal. The modified circuit is shown in Fig. 6. Here the crystal is mounted between two flat, carefully machined electrodes, which hold it in place and permit the application of radio-frequency potentials derived from the oscillatory plate tank circuit.

Thus, with this substitution made, the tuned oscillatory electrical circuit consisting of grid tank coil, grid tank capacitor, and grid coupling capacitor has been replaced by a mechanically resonant, oscillatory crystalline device in a mechanical mount. It is essential to recognize that this concept is of the utmost importance in the circuit analysis presented later in this chapter.

10. Circuit Operation

It was stated in Par. 4 that sustained oscillations may be explained on the basis of three phenomena: (a) shock excitation of the $L-C$ tank by some change in tube or circuit voltage, (b) amplification, and (c) positive or in-phase feedback from output to input circuit.

The oscillator whose circuit is given in Fig. 6 may be analyzed according to these actions. When plate power ($B+$) is applied by closing the switch, the triode becomes conductive and a surge of plate current starts to flow through $L2$, causing a magnetic field to build up around the coil. As the switch is closed, the rapid rate of increase of the intensity of the magnetic field induces a voltage by self-induction across $L2$, causing $C2$ to charge. As the plate current approaches maximum and tends to stabilize, the field tends to become static and the inductive voltage drop disappears. It is at this point that the true oscillatory process begins, with oscillations taking place in $L2-C2$ at the resonant frequency.

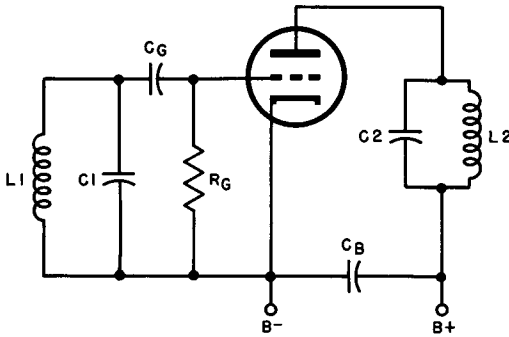

Fig. 5. TPTG oscillator circuit.

As C_2 begins to discharge to start its normally damped oscillatory cycle, the changing potential on this capacitor is transferred electrostatically through the tube's grid-plate capacitance and placed across the crystal. As a result, the crystal distorts physically in the particular mode for which it was designed. Because this distortion produces a voltage across the crystal faces, and because this voltage is fed to the control grid of the tube, the crystal now constitutes the input circuit—a circuit that develops a voltage whose frequency is determined by the crystal and holder constants.

Thus, the input voltage from the crystal is amplified by the tube, a part of the output energy being used to sustain plate-tank oscillations and a smaller part being fed back to keep the crystal vibrating. The action is identical with that of the TPTG oscillator except that the crystal has replaced the resonant circuit and the grid-coupling capacitor.

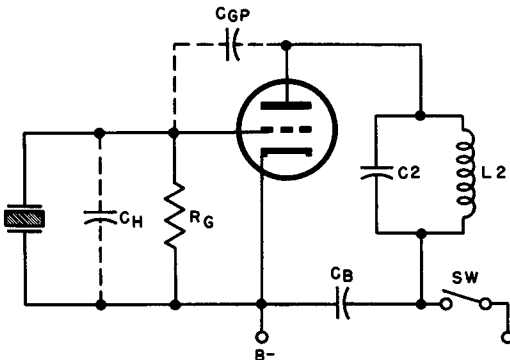

Fig. 6. TPTG circuit with crystal substituted for grid tank.

Figure 6 shows that C_{gp} , the capacitance between grid and plate inside the tube, may be simulated by an actual capacitor drawn outside the envelope and that the capacitance between the holder electrodes may be shown as a capacitor C_H , in parallel with the crystal.

While an oscillator is operating, it creates its own bias by grid conduction. As the crystal vibrates and generates piezo-electric potentials, the control grid is driven into conduction on positive peaks, current flows downward through R_g , the bias voltage developing across this resistor and C_H . A more extended discussion of crystal oscillator bias appears later in this chapter and in the practical circuits presented in Chap. 4.

11. Equivalent Circuit of the Crystal Oscillator

The very close electrical resemblance that a crystal bears to a tuned circuit (see Par. 8) makes it possible to analyze circuit operation on the basis of an *equivalent circuit*, in which the crystal is visualized and discussed as though it were composed of resistance, capacitance, and inductance.

Frequency versus impedance response curves (Fig. 7) indicate that a crystal in its holder or mounting behaves like a series resonant L - C circuit with an extremely high Q (X_L/R). Examination of the curve discloses that the impedance of the crystal unit is close to zero at the resonant frequency, rising to a peak at a second frequency called the anti-resonant frequency. The reduction of impedance with rising frequency in the illustration is shown between the ordinate axis and f_r (resonant frequency) and the sharp rise of impedance between f_r and f_a (anti-resonant frequency). The steep slope of the sides of the curve and the large differential between the impedance at f_r and f_a immediately suggest that the Q is high; that view is supported by the great difference between the pure resistance (R in the figure) and the total maximum impedance at the peak of the curve.

Thus, the equivalent circuit of a crystal consists of an inductance (L), a series capacitance (C), a series resistance (R), and a shunt capacitance (C_H), representing the capacitance of the crystal holder. (See Fig. 8.) It is to be assumed that the frequency at which L and C are in resonance is also the frequency of mechanical

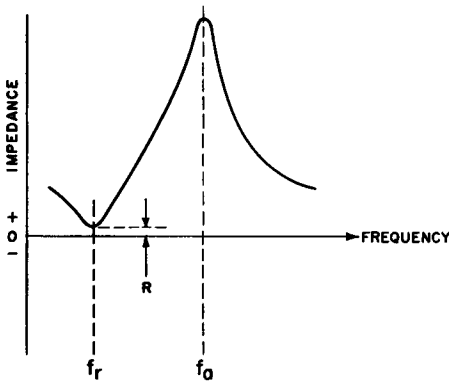

Fig. 7. Impedance - versus - frequency characteristic of a crystal.

resonance of the crystal. The electrical energy consumed by the equivalent L - C - R circuit is that which the circuit supplies to maintain crystal vibration; below resonance, the arrangement is capacitive in nature—as in any series resonant circuit—because the equivalent capacitive reactance is larger than the equivalent inductive reactance at the lower frequency; above resonance, the circuit is inductive. At resonance, of course, the reactive components disappear and the crystal is purely resistive.

The magnitudes of L , C , R , and C_H that enter into equivalent electrical network are determined primarily by the thickness of the crystal, the orientation of the plate to the crystal axes, the type of mounting, and the mode of vibration. Comparing the electrical constants with the mechanical characteristics of the crystal, it may be demonstrated that:

L is equivalent to the vibrating *mass* of the plate

C is equivalent to the stiffness or mechanical compliance

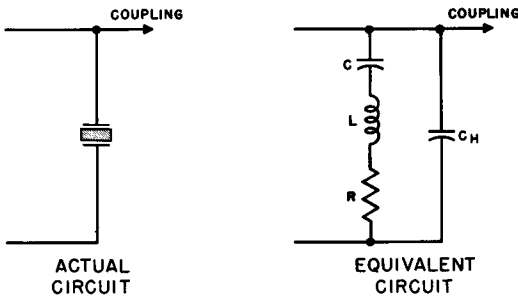

Fig. 8. Actual and equivalent circuits of a crystal.

R is equivalent to the losses due to friction and *acoustic* radiation

For a typical 5-mc crystal representative values for these constants might be:

$$L = .05 \text{ henry}$$

$$C = .02 \text{ } \mu\mu\text{f}$$

$$R = 50 \text{ ohms}$$

The Q of this particular crystal is computed as follows:

$$Q = \frac{X_L}{R} = \frac{2 \pi f L}{R}$$

$$Q = \frac{6.28 \times 5 \times 10^6 \times .05}{50}$$

$$Q = 31,400.$$

Hence, when one recalls that a Q of 100 for an ordinary L - C resonant circuit is considered high, a value such as that obtained above is quite remarkable.

One other important fact may be gleaned from the equivalent circuit: as shown in Fig. 8, the point at which coupling to the external circuit (to the grid of the vacuum tube in the case of the Miller oscillator) occurs is the junction between C and C_H . The extent of coupling is obviously dependent upon the ratio of these capacitances, since they form a voltage divider with the largest potential being developed across the smaller capacitance (the larger capacitive reactance). The coupling voltage appears across C_H and, for the typical crystal discussed in this paragraph, C_H might be approximately 12 $\mu\mu\text{f}$. Thus, the ratio is:

$$C/C_H = .02/12 = .002$$

This figure is very small and signifies that only a tiny fraction of the total crystal energy is coupled to the amplifier. Loose coupling like this makes the crystal relatively independent of load conditions—another very important favorable characteristic.

12. Crystal Oscillator Bias

In general, there are several ways in which grid bias is supplied in vacuum tube circuits:

a. *Fixed bias*, from a source independent of the tube's immediate circuit section. Examples of such sources are bias power supplies and bias batteries. In such an arrangement, the bias voltage

value is not affected by actions in the tube's immediate functional circuit.

b. *Cathode bias*, in which bias is the voltage drop across a resistor connected in series with the tube's cathode return lead. A bypass capacitor is usually connected across the cathode resistor to shunt a-c signal from the bias voltage. In this arrangement, bias voltage is proportional to plate current plus grid current (plus screen grid current in tetrodes, beam tubes, and pentodes). Thus, if plate current tends to become excessive, bias increases and tends to compensate and protect the tube.

c. *Grid leak bias*, which is of two types:

(1) In amplifiers in which there is no grid current resulting from signal drive, a very high resistance (10 megohms or greater) is sometimes connected between grid and cathode. The minute current from the grid due to the velocity of electrons in the tube's electron stream striking it produce sufficient voltage drop in the grid resistor to develop required bias. Signal drive must be kept within the bias range and not drive the grid positive.

(2) In amplifiers and oscillators in which there is grid current from signal voltage, a moderate value of resistance is connected between grid and cathode. This rectified signal grid current passes through the grid resistance, producing a voltage drop, which is the bias. The development of bias by this method is illustrated in Fig. 9.

In oscillators, fluctuations of load or supply voltages may cause a temporary drop of grid excitation voltage. If fixed bias (Par. 11a. above) were employed, any lowering of grid signal voltage would lower plate signal voltage. Then the feedback would decrease and cause even lower grid signal voltage. Thus any lowering of signal in the oscillator would be accelerated and the circuit might rapidly go out of oscillation. Also, it would be difficult

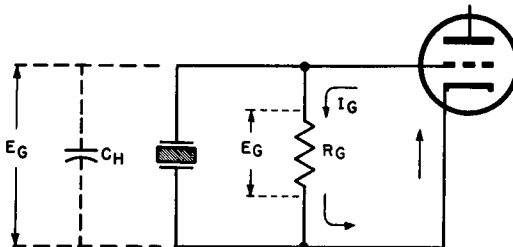

Fig. 9 How grid-leak bias is developed from grid circuit.

to get oscillations started, because there would be no grid current until the signals in the circuit were almost of normal strength. The oscillator would thus not be "self-starting." For these reasons, fixed bias is never used in practical oscillator circuits for the complete bias supply.

Cathode bias varies with plate (or more exactly, cathode) current. Grid current also contributes slightly, but is so much smaller than plate current (usually) that bias is primarily affected by the latter. When a cathode-biased oscillator is turned on, full plate current starts to flow and full bias is established, preventing start of oscillations. Without oscillation, plate current stays at full value and bias is fixed, and would not be affected by a signal voltage even if one were present. Thus, cathode bias alone is not suitable for oscillators, although it is occasionally used with grid leak bias, to protect the tube against excessive plate current.

Grid leak bias of the very high resistance type [C (1) above] is not suitable for ordinary oscillators, because it cannot be used with the signal current flow required in oscillators.

The other type of grid leak bias [C (2) above] can exist only when there is a grid signal present. This means that when the oscillator is first turned on, there is zero bias on the tube. Grid current and oscillation can begin immediately, making the oscillator fully self-starting. In addition, when the amplitude of oscillations tends to become excessive, the increase of grid current increases bias and reduces the tube gain, compensating for the tendency toward amplitude increase. Similarly, a tendency toward lower-than-normal amplitude lowers bias, increasing tube gain and compensating for the fall-off tendency. The oscillator thus becomes to a large extent "self-regulating" as well as self-starting. For these reasons, grid leak bias is virtually always used in oscillators.

The operation of most r-f oscillators is of the class C type. In fact, an oscillator can be quite accurately pictured to be a class C amplifier whose output circuit is appropriately coupled to its input circuit. Operating class C, an oscillator employs a rather high value of bias, approximating twice the cutoff value. Without the feedback signal, there would be no plate current at this bias. But as mentioned above, the bias is initially zero, and builds up with the signal. When oscillations have built up, the grid signal is strong

enough to more than overcome the full bias and drive the tube into both grid and plate conduction. In so doing, the grid signal passes the transconductance (G_m) of the tube from zero up to a high peak value at the peak of this grid signal. The plate current flows only during the relatively short intervals when the grid is driven more positive than the cutoff bias, and this accounts for the high efficiency derived from class C operation.

13. Crystal Oscillator Power Output

The power output obtainable from a crystal oscillator is limited by two factors:

- a. Heating of the crystal due to large r-f currents at high frequencies.
- b. Strains set up by mechanical vibration of the crystal at lower frequencies.

When the aim is to obtain high frequency stability, heating in the crystal is intolerable because it causes a frequency drift that may be appreciable even with special crystal cuts having low temperature coefficients. On the other hand, strong mechanical strains are apt to fracture the crystal if allowed to continue for any length of time.

With these limiting factors taken into account, present practice calls for the use of low-power-output crystal circuits using very loose coupling to the crystal to keep crystal current down to a minimum. In modern transmitters, Class C r-f amplifiers are used to increase the power output to the desired level.

14. Tuning and Measurement Procedure in the Basic Crystal Oscillator

The tuning procedure used with the basic crystal oscillator entails two current measurements, plate current and rectified grid current (Fig. 10), both of which are in the order of milliamperes (d-c) in practical equipment. The plate circuit milliammeter provides an indication of average plate efficiency and should read as low as possible while the oscillator is stable in operation as explained below; the grid circuit milliammeter gives a direct current reading, which is a measure of the crystal excitation.

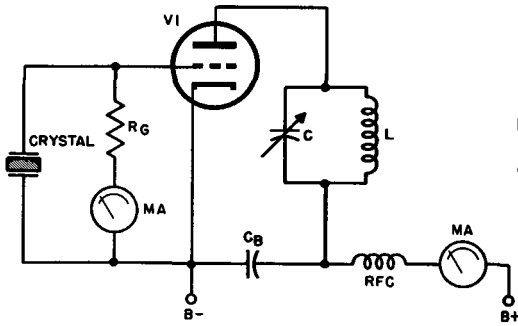

Fig. 10. Basic crystal oscillator circuit showing grid and plate current indications useful in tuning.

Most operators apply plate power with the tuning capacitor fully meshed; at maximum capacitance, the plate current is high (point *A* in Fig. 11) so that tuning must be deft and quick if the tube is to be protected against excessive heating. The capacitor is then swung outward toward lower capacitance and, just about at the resonant frequency, the plate milliammeter will show a sudden dip in its reading. At the same instant, the grid meter will begin to read the rectified grid current. The capacitance should be further reduced slightly to bring the operating point up slightly on the curve, as shown in Fig. 11; this provides good stability without much loss of efficiency and is highly advisable, because leaving the capacitance at the peak of the dip sets up hypercritical conditions which may cause the oscillator to be erratic, especially if it is being keyed.

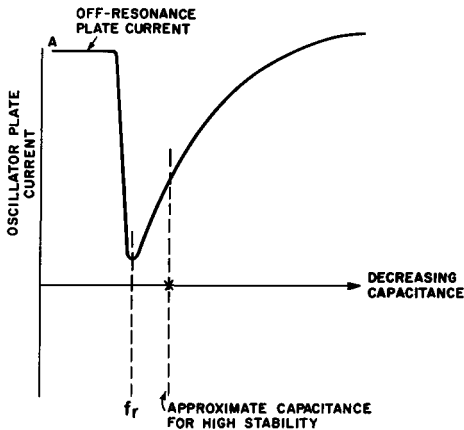

Fig. 11. Variation of plate current in crystal oscillator as tuning capacitance is varied.

In most instances, the grid meter may be replaced by a small 6-volt pilot lamp, once the oscillator characteristics have been determined. In this connection, it not only offers a visual indication of the degree of excitation but also serves as a fuse that protects the crystal against r-f overload and possible fracture.

When a crystal oscillator is coupled to a radio-frequency amplifier, the tuning curve broadens and flattens simultaneously, almost eliminating the critical point entirely. It is still recommended practice, however, to detune even a loaded oscillator in the direction of reduced capacitance (higher frequency) to achieve maximum stability.

15. Review Questions

1. What is meant by the Piezo-electric effect? Name three substances exhibiting this property.
2. Sketch a quartz crystal of the hexagonal cross-section type. Show clearly the X, Y, and Z axes of this crystal.
3. Which axes are the "optical axes"? Which are the "mechanical axes"? Which are the "electrical axes"?
4. What is meant by "fundamental tone," "second overtone," and "third harmonic"?
5. Define "flexure mode," "shear mode," "longitudinal mode," and "torsional mode."
6. Draw the basic Miller oscillator and explain the circuit operation.
7. Draw the equivalent circuit of the crystal.
8. What factors determine the magnitudes of L , C , R , and C_h in the equivalent circuit?
9. What factors limit the power output obtainable from a crystal oscillator?
10. Describe the tuning procedure used with the basic crystal oscillator and explain what the current measurements indicate.

Chapter 3

CRYSTAL TECHNIQUES

16. The Meaning of Orientation

The frequency and temperature characteristics of a crystal plate of given thickness and surface area depend primarily upon the way it is cut from the mother stone, or its *orientation* to the *X*, *Y*, and *Z* axes. (See Fig. 2.) Early crystals were either *X*-cut or *Y*-cut because of their respective orientations to the electrical and mechanical axes of the stone. These cuts and others that followed are described in the next paragraphs. Research, both past and present, is directed toward obtaining a cut that has little or no temperature sensitivity; for example, the *X*-cut crystal tends to fall in frequency as the temperature goes up and vice versa, while the *Y*-cut crystal behaves in the opposite manner. A temperature-sensitive crystal may serve as a precise frequency control only if it operates in a *crystal oven*, a thermostatically controlled heat box that maintains the temperature of the crystal constant at some predetermined level.

The first significant step toward temperature stability in crystal cutting came in 1934,¹ with the development of the *AT* cut and the *BT* cut. In 1937 cuts that were superior to the *AT* and *BT* in some ways were announced by the Bell Telephone Laboratories.² Concurrently, RCA scientists developed the *V* cut,³ an orientation sub-

¹ Lack, Williard, and Flair of Bell Telephone Laboratories.

² Williard and Hight (*CT*, *DT*, *ET*, and *FT* cuts).

³ Bokovoy and Baldwin.

stantially parallel to the *AT* and *BT* cuts. Finally, in 1940, the *GT* cut—the most stable resonator ever devised—was announced by W. P. Mason.

The large number of practical orientations now in use has made it necessary to devise a standard system by means of which any given plate position or cut may be described simply and completely. In 1949 such a system was proposed by the I.R.E. and has been almost universally adopted in this country. Its mechanism and application will be discussed later in this chapter, following the discussion below on temperature coefficient.

17. Temperature Coefficient

One of the most important characteristics of a crystal oscillator intended for frequency control is its ability to maintain constant frequency under various conditions of ambient temperature. Hence, when the performance of a crystal of particular cut is to be described, its *temperature coefficient* must be given in the form of some accepted, conventional expression.

The temperature coefficient of a crystal contains two dimensions: a + or – factor, depending upon the direction in which the frequency creeps with rising temperature, and a numerical quantity that expresses the amount of frequency change in parts per million per degree Centigrade. Several examples will clarify this.

A certain *Y*-cut crystal is said to have a temperature coefficient of +80 p/m/°C. This means that for one degree Centigrade of rise in temperature, its frequency *rises* 80 cps for one mc of its ground frequency. Suppose this crystal is ground to operate at 5 mc, at zero°C; suppose further that the temperature rises to 10°C. Its new frequency is $5 \times 10^6 + 80 \times 5 \times 10 = 5 \times 10^6 + .004 \times 10^6 = 5.004$ mc.

In another example, an *X*-cut crystal has a temperature coefficient of –20 p/m/°C (or –20 cps/mc/°C—another way of writing the same thing). It is rated to operate at 450 kc when its temperature is 20°C. At what frequency does it operate if the temperature rises to 25°C?

The best way to start is to convert all frequencies into cps and then solve as in the previous example. (Note that this crystal has a negative temperature coefficient so that the change of frequency must be subtracted from ground frequency to obtain the new frequency.)

$450 \times 10^3 - 20 \times .450 \times 5 = 450 \times 10^3 - .045 \times 10^8 = 449.955 \text{ kc.}$
 (In the above solution, note that 450 kc is changed to 450×10^3 to make it read in cps. Also, the middle term of the coefficient is .450 because 450 kc is 450/1000 of one mc.)

18. Pictorial Method of Specifying Crystal Cut Orientation

When the X and Y cuts were the only types in use, it was quite easy to describe the exact orientation of the plates by means of picture diagrams like that of Fig. 12. Such diagrams were supported by verbal descriptions as follows:

"X-cut crystals are removed from the mother stone by cutting the plate so that its faces are perpendicular to the X-axis or electrical axis of the stone. Y-cut crystals have their faces perpendicular to the mechanical or Y axis."

It is quite evident, however, that the discovery of the more complex cuts in which there are various angular rotations of the plate around one, two, or all three axes makes such a descriptive system too cumbersome to be practical.

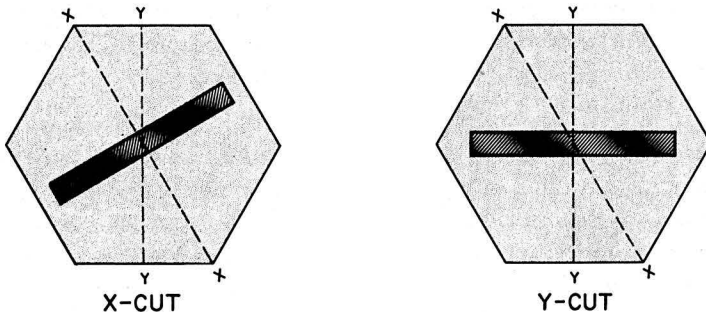

Fig. 12. Locations of X and Y cuts in a "mother" stone.

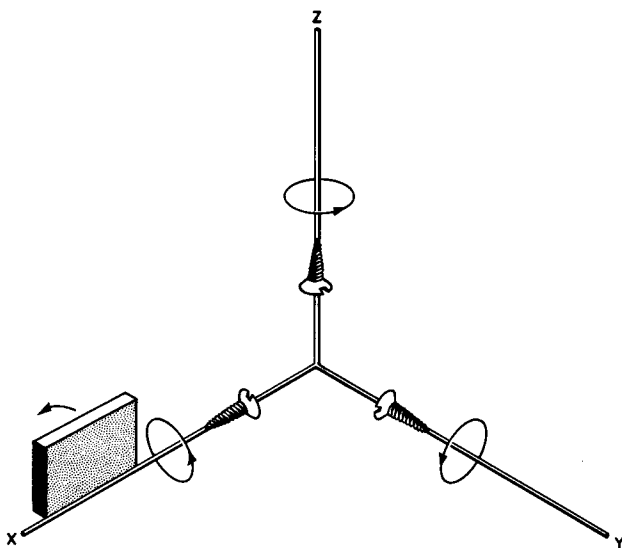

Fig. 13. Basic axes used in orientation specification, and positive rotation directions.

19. The IRE System of Orientation Specification

Since the orientation of plates depends upon the manner and degree of rotation around the X , Y , and Z axes of the stone, it is necessary first to agree upon a method of describing whether the rotation is clockwise or counterclockwise around a given axis. First, note in Fig. 13 the three coordinate axes that are mutually perpendicular just like the axes in a quartz crystal. Starting from the origin of the coordinates are three wood screws that are to be pictured as being driven towards the ends of the axes in the usual manner, i.e., by turning the screwdriver clockwise as one faces in the direction of drive. The arrows show the direction of rotation for this condition.

If a quartz plate is now pictured as resting on edge, say on the X axis and is rotated as shown, its direction is that of the driven screw and, by convention, is said to rotate in a *positive direction*; if it moved opposite to the screw direction, the rotation is called *negative*. Exactly the same convention is adopted for the Y and Z axes so that specifying the axis of rotation and the number of degrees preceded by a plus or minus sign completely describes the character and extent of motion.

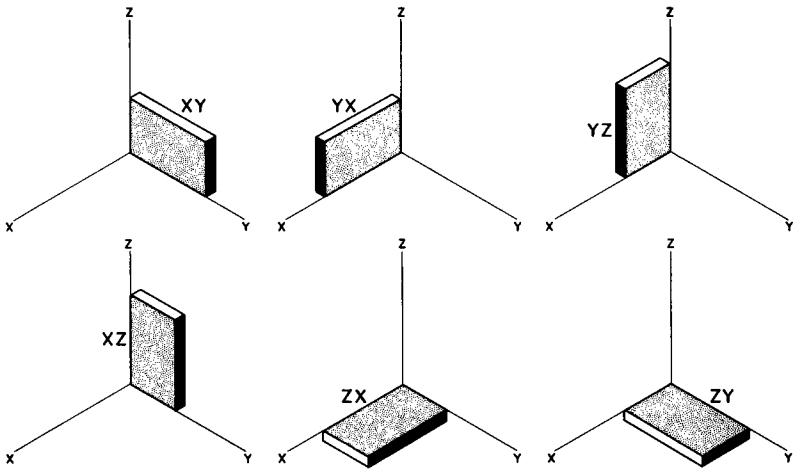

Fig. 14. Basic crystal locations before rotation, and their designations.

To specify the orientation of the cut, the crystal blank is assumed to have a hypothetical initial position, with one corner at the origin of the coordinate system, and the thickness, width, and length lying along the axes. There are six possible initial positions, each of which is described by two letters, the first letter indicating the thickness axis and the second letter the length axis. These positions are thus designated xy , xz , yx , yz , zx , and zy . Figs. 13 and 14 should make clear what is meant by each of these initial positions.

The blank shown in Fig. 13 has its thickness along the Y axis and its length along the X axis. Thus, this initial position is specified as yx . The reader should study each of the five positions in Fig. 14 to be certain that he understands the terminology.

In practice, the initial position is chosen so that the final orientation may be reached with a minimum number of rotations. These rotations are taken about axes that *parallel* the dimensions of the crystal at the time of rotation and are designated by the letters t , w , and l standing for thickness, width, and length.

The examples given below illustrate the use of this system.

Example 1 (Fig. 15): The geometrical specification of the rotation of the plate is given as $yzw + 30$ degrees. This means that

the initial position is yz and that the blank is rotated 30 degrees in a positive direction around the w (or width axis).

Example 2 (Fig. 16): The specification is $xyt-30$ degrees. Thus, the blank lies with its length along the y axis, its thickness along the x axis, and is rotated opposite from the screw direction along the thickness axis 30 degrees. (Hence the minus sign before the angle specification.)

Example 3 (Fig. 17): This blank starts with its thickness axis along y and its length along x , with two sequential rotations needed for it to reach its final orientation. The first rotation occurs along its thickness axis, 10 degrees downward or -10 degrees. The second rotation takes place in a positive direction around the length axis over an angle of 45 degrees ($+45$ degrees). The specification for its final position is then $yxtl -10$ degrees/ $+45$ degrees.

Most crystal cuts are oriented by using a single rotation such as in Figs. 15 and 16; a few, however, require two and sometimes the maximum of three rotations.

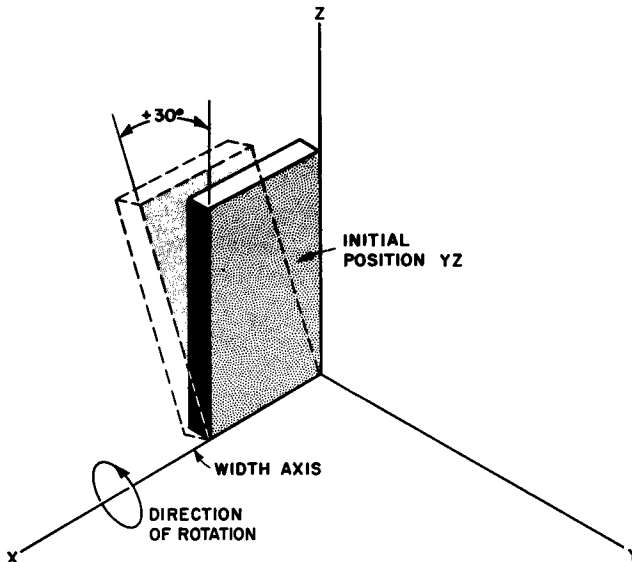

Fig. 15. Illustration of $yzw + 30$ degrees orientation.

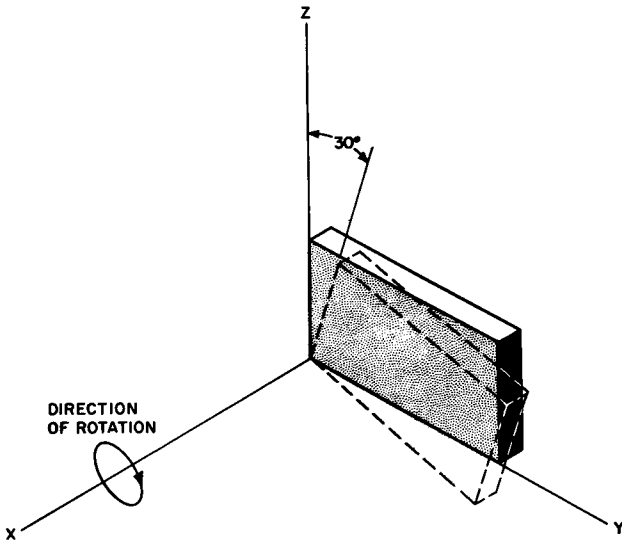

Fig. 16. Illustration of $xyt - 30$ degrees orientation.

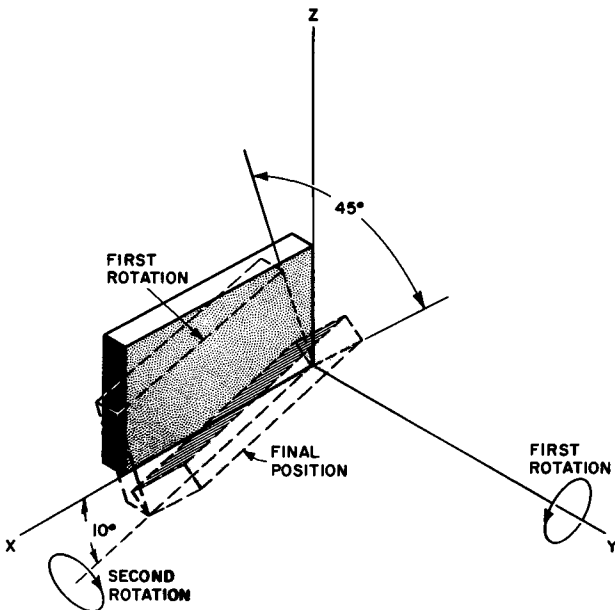

Fig. 17. Orientation of specified $xyt - 10$ degrees / + 45 degrees. Note that two successive rotations are necessary: (1) along thickness axis downward 10 degrees, (2) along the length axis clockwise 45 degrees.

20. Popular Cut Orientations

Standard quartz elements are conventionally divided into two groups: (1) Rotated X -cut crystals and (2) rotated Y -cut crystals. The X and Y cuts have their thickness dimensions parallel to the X and Y axes, respectively, with the length and width dimensions parallel to the remaining axes. Thus, in describing an orientation, the X cut is the equivalent of the two initial positions xy and xz (see Fig. 14) and the Y cut is initially in the yx or yz position. Belonging to the X and Y groups, then, are those crystals whose rotation symbols begin with the letters x and y respectively. As a general rule, the low-frequency units are cut from the X group and the medium to high-frequency blanks from the Y group. With one or two exceptions, Z -cut crystals (thickness parallel to Z -axis) are impractical.

In Table 1, an attempt has been made to show the differences between popular cuts with respect to orientation, mode of vibration, customary frequency range, and range of temperature coefficients.

21. Thickness-Frequency Ratio (Frequency Factor)

For most crystal cuts, the frequency is determined chiefly by the thickness of the finished blank. Depending upon the orientation, the thickness for a given frequency varies considerably from cut to cut so that it is convenient to express the thickness-frequency characteristics of each orientation by a constant number derived from the equation:

$$f = k/t$$

where f = frequency in mc
 t = thickness in thousandths
of an inch

The equation indicates that frequency is inversely proportional to thickness so that k , the product of f and t , is a large number for those crystals which are relatively thick even at high frequencies.

For example, the X cut has a frequency factor of 112.6 while an AT cut is rated at 66.4. Thus, for a given frequency of oscillation, the AT cut is one of the thinnest of blanks.

TABLE 1

DIFFERENCES BETWEEN POPULAR CRYSTAL CUTS

<i>Cut</i>	<i>Specifications</i>	<i>Mode of vibration</i>	<i>Frequency Range in Kc</i>	<i>Temperature Coefficient</i>
<i>X</i>	<i>xy</i> or <i>xz</i>	longitudinal (compressional)	350 to 20,000	20 to 25 p/m/°C (negative)
5-deg. <i>X</i>	<i>zxt</i> 5 deg.	flexure	10 to 100	varies with length:width ratio
<i>Y</i>	<i>yx</i> or <i>yz</i>	thickness shear	500 to 20,000	+ 80 to 100 p/m/°C (positive)
<i>AT</i>	<i>zxl</i> 35 deg. 25 min.	thickness shear	500 to 100,000	0 p/m/°C at 25°C *
<i>BT</i> (also called <i>YT</i>)	<i>-xyl</i> -49 deg. 8 min.	thickness shear	1000 to 75,000	0 p/m/°C at 25°C †
<i>CT</i>	<i>yxl</i> 37 deg. 40 min.	face shear	300 to 1100	0 p/m/°C at 25°C ‡
<i>DT</i>	<i>yxl</i> 52 deg. 30 min.	face shear	60 to 500	0 p/m/°C at 25°C §
<i>GT</i>	<i>yxlt</i> -51 deg. 7.5 min. /45 deg.	longitudinal	100 to 500	appr. 0 p/m/°C from -25° to + 75°C

* The *AT*-cut crystal may be oriented to give a zero temperature coefficient at any one of a number of different temperatures. The particular *AT* cut used here is one designed to provide zero coefficient at about room temperature.

† The *BT* cut does not have the ability to stay on frequency over as large a variation from room temperature as the *AT* cut.

‡ The *CT* cut has the same limitations as the *BT* cut.

§ The *DT* cut is especially useful for low frequency standards operating at room temperature.

|| Note the long range over which the temperature coefficient is virtually zero.

The frequency factors for the popular cuts are as follows:

X Cut	112.6
Y Cut	77.0
AT Cut	66.4
BT Cut	100.
CT Cut	122.*
DT Cut	81.
GT Cut	131.†

* In the case of the CT cut, whose vibrational mode is face shear, t is the length or width rather than the thickness.

† In longitudinal mode, width rather than thickness controls frequency.

22. Summary of Advantages and Disadvantages of Various Cuts

The advantages and disadvantages of each of the types of cuts specified in Par. 20 are presented for convenience in Table 2.

TABLE 2

<i>Cut</i>	<i>Advantages</i>	<i>Disadvantages</i>
X	Mechanical stability Economical type of cut	Large temperature coefficient Tendency to jump from one mode to another
5-deg. X	Low temperature coefficient Large ratio of stored mechanical to electrical energy	Must be made in the form of long thin bars to fit in special types of holders in which there is little tendency to jump between modes
Y	Most active cut of all (large ratio of stored mechanical to electrical energy) High mechanical strength	Large temperature coefficient Poor frequency spectrum

TABLE 2 (Continued)

<i>Cut</i>	<i>Advantages</i>	<i>Disadvantages</i>
<i>AT</i>	Excellent temperature-frequency characteristics Excellent frequency spectrum	Difficult to fabricate for optimum operation without coupling between modes
<i>BT</i>	Thicker crystals possible at high frequencies (higher frequency factor than <i>AT</i>)	Not as active as <i>AT</i> cut Too thick for low-frequencies Difficult to fabricate Zero temperature coefficient over very small range of temperatures
<i>CT</i>	Similar to <i>BT</i> cut	Large face dimensions make it uneconomical for very low frequencies Narrow useful frequency spectrum
<i>DT</i>	Excellent for generating low radio-frequencies	Does not perform well at frequencies over 500 kc
<i>GT</i>	Greatest stability yet obtained with any cut (does not vary more than one part in one million over a range of 100°C)	Most expensive of all types because of painstaking labor required in exact orientation and dimensioning

23. Mounts and Supports for Finished Crystals

In general, the requisites for a satisfactory crystal support include: (a) establishment of good electrical connection to the elec-

trodes, (b) least possible damping or mechanical impedance acting on vibrating blank, (c) firm support of the crystal to protect against mechanical shock and vibration, and (d) adaptability for hermetic sealing.

Military Standard crystal holders currently recommended for use in equipment of new design include only two categories: *pressure mounting* and *wire mounting*. The first type involves a support in which the crystal is placed between two elements under pressure; the latter type consists of wire supports cemented directly to the crystal. In this review, these general classifications are further subdivided into smaller groups that differ from each other sufficiently to warrant separate illustration.

Pressure Sandwich. In holders of this type, the crystal is held between two flat electrodes under light spring pressure. In a commercial assembly, identical electrodes are, in turn, sandwiched between two contact plates that connect to two metal prongs. The prongs serve simultaneously as electrical contacts and plugs that fit into the holder socket (Fig. 18). A fibre washer, the pressure spring, and a neoprene gasket for hermetic sealing complete the assembly. When the cover is screwed down to the holder case, the unit may be used in any position. The advantages of pressure sandwiches include ruggedness and low cost; due to the spring pressure, however, a certain amount of mechanical impedance is added to the crystal so that crystals mounted in this type of holder exhibit less activity than in more critically designed mounts.

Air Gap Mounts. The holder shown in Fig. 18 may be changed to an air gap type by adding tiny glass spacers between the two electrodes so that the crystal rests on the lower one while the upper electrode is separated from the crystal by an air gap of about 3 mils in thickness. Unfortunately, this type of holder loses its ruggedness because the crystal is free to move about in the space between electrodes. *Clamped Air Gap* mounts do away with this difficulty by holding the crystal in place at the four corners while air gaps exist above and below the crystal over much of its area. For some crystal modes, instead of clamping at the corners, the crystal is held by small triangular "lands" near the center of the long edge (*nodal clamping*). Corner clamping is particularly effective with high-frequency thickness-shear crystals, while nodal clamping is used mainly for low-frequency crystals that vibrate in a longitudinal mode.

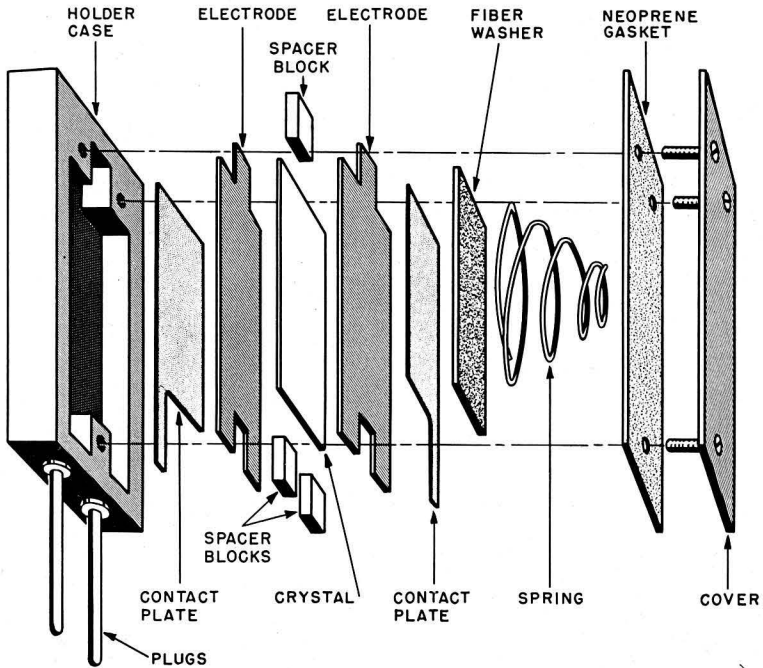
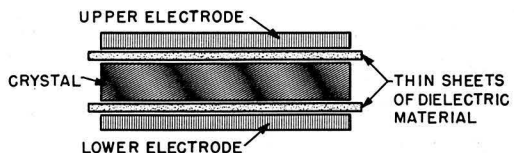

Fig. 18. Construction of "pressure-sandwich" type of mount.

Dielectric Sandwich. One of the dangers involved in overdriving a crystal in either a pressure sandwich or air-gap mount is that of arcing between the electrodes and the quartz, an effect that may puncture the crystal or oxidize the electrodes so as to render the unit useless. Arcing is due to ionization of air between the blank and the electrodes; the problem this introduces may be minimized by inserting thin sheets of high dielectric material, such as mica, fused quartz, cellophane, rubber, etc., between the electrodes and the faces of the crystal (Fig. 19).

Button Mounts. The ceramic button crystal mount represents the ultimate thus far in crystal-holder design via the sandwich and

Fig. 19. "Dielectric sandwich" type of mount.



air-gap evolutionary chain. The ceramic button electrodes are very thin metallic platings that cover a small circular area at the center of each ceramic plate. A tiny air gap, between three and five *microns* (thousandths of millimeters), is obtained by means of thin plated metal risers at the edges of the buttons. (See Figure 20.) A notch in each ceramic button permits an extension of the electrode plating on to the other side for contact with external leads. Button mounts have very low shunt capacitance, practically no spurious-mode tendencies, and little damping and are quite rugged.

Plated Crystals. Thin films of gold or silver may be deposited on crystal faces by evaporating the metal in a vacuum and allowing it to condense on the exposed portions of the crystal; another technique coming into favor is a sputtering process in which crystals are subject to ionic bombardment from high voltage negative elec-

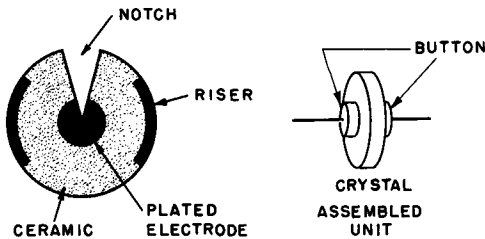

Fig. 20. Button type of mount.

trodes of the desired metal, the process again being carried on in a vacuum. Silver and gold are favored because of the strength of the solder bonds possible with these metals, their resistance to corrosion, and the ease with which they are handled. Other metals used in special cases are nickel, copper, and aluminum, the last being preferred where a very light weight element is required. Plated electrodes have many advantages: they provide maximum piezoelectric coupling, possibility of arcing between crystal and electrodes is reduced, there is no possibility of crystal shifting between electrodes, frictional losses between crystal and electrodes are removed, and the plating protects the crystal from erosion.

Plated crystals may be supported between pressure pins or pressure knife edges for nodal or edge clamping.

Wire Mounting. One of the chief disadvantages of any type of pressure mount is the damping effect caused by the electrodes or

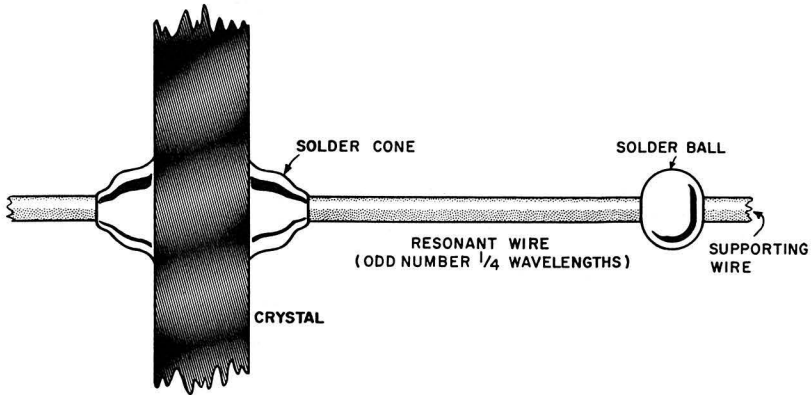

Fig. 21. Wire type of mount.

contact plates, yet the fact that pressure is present brings about a desirable condition—that of reasonable immunity to shock and vibration. Wire mounting makes it possible to retain the advantages of shock-proof design while, at the same time, reducing the effects of damping to a minimum.

By mounting the crystal as shown in Fig. 21, the wire lengths indicated may be so “tuned” as to become mechanically resonant to the crystal frequency; under these conditions, the wires vibrate with the blank and return mechanical energy to the system, reducing the impedance to a very low figure.

In the fabrication process, the crystal is first given a pair of small silver footings to which the wires are later to be attached; these footings are only 40 to 90 mils in diameter. The electrodes are then plated on the crystal by evaporation or sputtering with silver (or sometimes gold, if corrosion resistance is important enough to warrant it). The mounting wires are phosphor-bronze, a material of high tensile strength and comparative immunity to metal “fatigue.” They are soldered to the footings and the solder spot is formed into a cone as shown in the figure. The mechanically resonant length of wire is then determined and a ball of solder, which (by virtue of its mass) serves as the terminus of the free resonant length of wire, is then soldered to the lead. The solder ball behaves as a clamped point, which reflects the wave energy back

to the crystal, and is placed at an odd quarter-wavelength from the peak of the solder cone. The supporting wires are then carefully bent to form springs and secured to the crystal holder prongs.

24. Crystal Ovens

Excellent as the temperature characteristics of the "T"-cut crystals may be, the rigorous frequency stability requirements in both commercial and military radio installations demand temperature control in many instances.

Small crystal ovens, occupying not much more volume than a good-sized receiving tube, are now almost universally depended upon to maintain constant frequency in all but broadcast station installations. Figure 22 is an exploded view of a small crystal oven equivalent to Military Type HD-54/U and, although it is not designed for precision control, it does offer improved stability for crystal controlled devices, especially those that undergo rapid extremes of temperature as found, for example, in aircraft.

The thermal key, shown as a part of the base assembly, is a metallic heat-distributing layer that makes close thermal contact with the base of the distributing shell around which the heaters are wound. The baffle is a plastic cover that forms the walls of the crystal chamber. Its purpose is to form a heat-storing as well as a heat-insulating layer between the heater distributing shell and the crystal unit. Two thermostats and two heaters are provided. One thermostat-heater combination is for quick oven warmup when the oven is first turned on. This thermostat is adjusted to open its associated heater circuit at a temperature just below the desired operating temperature while the second pair determines the op-

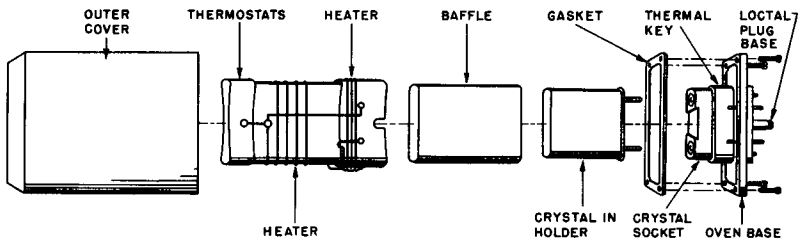

Fig. 22. Typical compact crystal oven which plugs into a local socket.

erating characteristics. The outer cover, a plastic composition, is large enough to provide a small air chamber around the crystal compartment.

The crystal oven illustrated in Fig. 22 is designed to plug into a regular 8-pin octal type of tube socket. Over an ambient temperature range from -55°C to $+55^{\circ}\text{C}$ it will maintain a maximum deviation within the range from -7° to $+6^{\circ}$ around its normal operating temperature of 75°C . It measures 1.9 inches in height, 1.4 inches in length, and 1.0 inch in width and weighs only 2 ounces.

25. Review Questions

1. Define the temperature coefficient as it pertains to crystals.
2. A Y-cut crystal is ground to operate at 3 mc at 20°C . Its temperature coefficient is listed as $+60$ p/m/ $^{\circ}\text{C}$. Calculate the operational frequency of the crystal if the temperature rises to 25°C .
3. Explain the IRE system of crystal orientation, developing at least two illustrations to explain your discussion.
4. Draw a diagram orienting the initial position of the crystal when given these specifications: xy , yx , yz , xz , zx , and zy .
5. What specification would the technician normally require in differentiating between the various crystal cuts?
6. List six different types of crystal cuts. Specify which of these are most commonly used in design applications.
7. Explain the term "frequency factor" and give the mathematical equation defining it.
8. Summarize the advantages and disadvantages of the following crystal cuts: x , y , AT , GT .
9. Differentiate between the pressure mounting and wire mounting types of crystal holders.
10. What is the function of a crystal oven?

Chapter 4

POPULAR CRYSTAL OSCILLATOR CIRCUITS

26. Circuit Classifications

From the standpoint of circuit design and the selection of crystal units for use as frequency control devices, crystal oscillator circuits may be conveniently classified as *parallel resonant* or *series resonant*.

The parallel resonant circuit is generally favored for use with crystals operating in their *fundamental* mode (lowest frequency to which the crystal can resonate), while series resonant arrangements are preferred when the crystal is to produce *overtones* or harmonics.

A subclassification often encountered is that which differentiates between straightforward triode oscillators and the electron-coupled type, which makes use of the screen grid element of a pentode to achieve increased stabilization of frequency.

This chapter will be confined to parallel resonant circuitry, both triode and electron-coupled, currently in use by amateurs, commercial communications companies, and the military. Series resonant circuits employing overtone crystals and other special forms of oscillators will be discussed in Chapter 5.

27. Standard Miller Oscillator

The fundamental circuit of this oscillator was discussed in Pars. 8 through 11 in connection with Figs. 6 through 9. A practical circuit using a 6J5GT/G is shown in Fig. 23. It is readily

evident from a comparison of this illustration with Fig. 6 that the circuits are identical except for the addition of two resistors, R_2 and R_3 . R_2 , in series with the grid leak resistor, carries the rectified grid current and develops a small voltage drop proportional to the excitation. An external milliammeter may be switched to the "MA" test point and ground to measure the amplitude of the excitation voltage without disturbing the circuit operation in any way. R_2 is very small in comparison to R_1 and therefore has negligible effect upon the grid leak bias. However, milliammeter resistance is small compared to R_2 , so virtually all the current goes through the meter and the reading is correct.

R_3 is a series dropping resistor inserted to reduce the plate voltage on the 6J5GT/G. This is the usual procedure when a power supply, common to other higher-powered stages in a transmitter, provides an output voltage that would be excessive if applied directly to the oscillator.

28. Miller Oscillator Using Screen Grid Tube

A screen grid tube—specifically a pentode or beam-power tube—offers a number of advantages as a crystal oscillator. The higher power sensitivity of a pentode makes possible greater output from the oscillator with the same or less crystal excitation, hence the crystal runs cooler; furthermore, pentodes of the well-shielded variety (6AC7, 6AG7, etc.) have so little capacitance between plate and control grid that it is almost impossible to overdrive the crystal

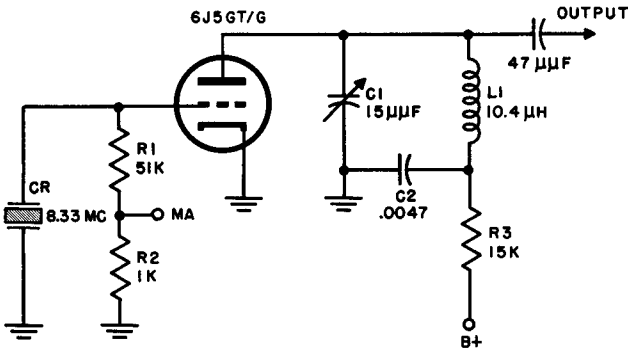

Fig. 23. Basic Miller oscillator circuit.

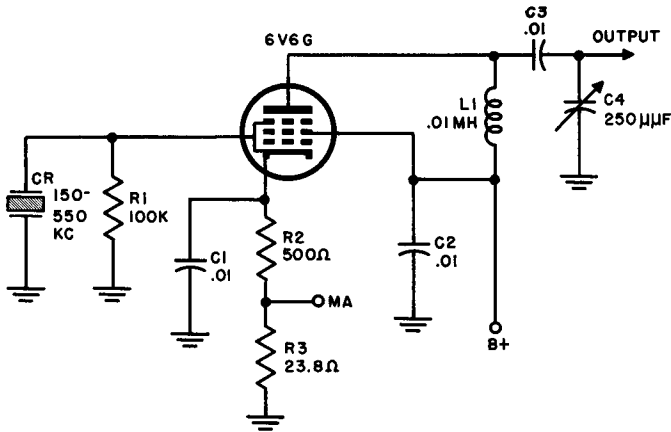

Fig. 24. Beam-tube Miller oscillator circuit.

in the Miller circuit. As a matter of fact, it is often necessary to *add* a small capacitance from plate to grid to form a second feedback loop to maintain oscillation. The circuit given in Fig. 24 does not need this additional capacitance because it uses a 6V6G, which has a high enough grid-plate capacitance.

The voltage applied to the plate and screen of the oscillator tube is relatively high (300 to 400 volts). Accordingly, for safety, cathode bias is provided in the form of a voltage drop across R_2 , a 500-ohm resistor. R_3 serves the same purpose as in the oscillator shown in Fig. 23—that of providing a test point for current measurement; here the cathode current, rather than the rectified grid current, may be read by switching the external milliammeter to the junction of R_2 and R_3 and to ground. Capacitor C_2 keeps the screen grid of the 6V6G at ground potential for r-f. C_3 , a comparatively large capacitor of low reactance at radio frequencies, passes r-f to complete the tuned circuit L_1 - C_4 but keeps d-c voltage off capacitor C_4 . This allows grounding of the rotor plates of C_4 , which is the tuning capacitor. C_1 is the cathode bypass capacitor, which provides a low impedance path for the plate circuit r-f current to return to the cathode.

29. Electron-Coupled Miller Oscillator

In this type of circuit, the screen grid of a pentode or beam power tube serves as the plate, and the plate of the tube becomes an output electrode. Since the potential of the screen grid varies with the radio-frequency energy generated by the oscillations in the screen tank, the electron stream that moves through the screen grid to the plate is *modulated* at the frequency of the crystal. The plate tank circuit, being resonant to the crystal frequency, oscillates as a result of the properly timed r-f pulses that reach it through this modulation process. The advantage of an electron-coupled crystal oscillator lies in the fact that the output circuit is completely isolated, capacitively, from the crystal circuit, being coupled only through the modulated electron stream. Thus, changes in output loading have little effect on crystal loading.

Figure 25 shows the circuit of a practical electron-coupled Miller crystal oscillator using a 6SJ7 pentode. Note the two tuned circuits and the safety bias resistor, R_2 . L_1 , C_3 , and C_2 comprise the screen tank while the plate tank is made up of L_2 , C_6 , and C_5 . Fixed capacitors C_2 and C_5 , which form a part of the two tuning networks, make it possible to use smaller variable capacitors (C_3 and C_6). This is always an advantage in that the tuning becomes broader and easier to handle.

30. The Fundamental Pierce Oscillator

The Pierce crystal oscillator has gained widespread acknowledgment as one having excellent frequency stability, great versatil-

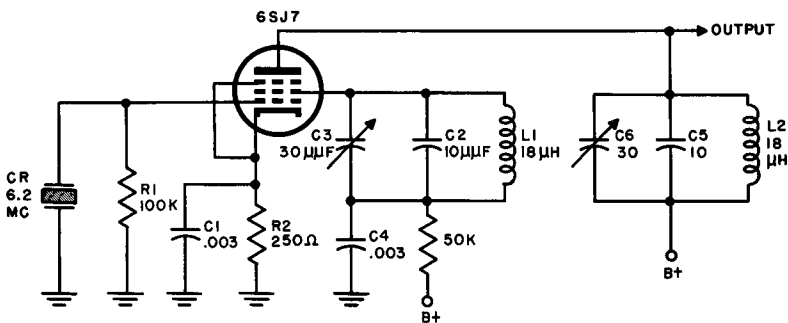

Fig. 25. Electron-coupled crystal oscillator.

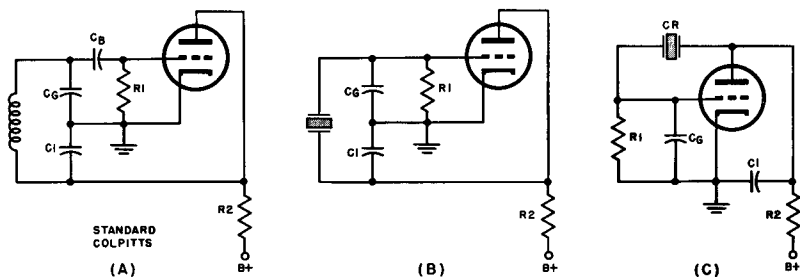

Fig. 26. (A) Colpitts oscillator circuit, self-excited, (B) crystal controlled colpitts circuit, which is the same as the Pierce circuit, (C) regular form of Pierce oscillator circuit.

ity, and extreme simplicity of construction. Although its output is not as great as that of a Miller oscillator using the same crystal unit, the feature of "tankless" oscillation makes it very easy to use with a multiplicity of crystals since it does not require retuning every time the crystal is changed.

The drawings in Fig. 26 (A) and (B) show the equivalence of the Pierce crystal oscillator and the standard Colpitts self-excited type. It will be recalled that the Colpitts oscillator sustains oscillations by virtue of the split tank capacitor C_g and C_i by means of which plate-to-grid feedback is achieved. Further examination of the circuit shows that capacitor C_b , necessary in the Colpitts to block high voltage d-c from the grid of the vacuum tube, is not required in the Pierce circuit because of the dielectric properties of the crystal and holder.

Otherwise, the circuits are identical, with the crystal unit replacing the tuning inductance of the Colpitts. For those who are accustomed to seeing the Pierce oscillator drawn somewhat differently, the conventional schematic layout is illustrated in Fig. 26 (C).

The use of a load resistor (R_2) makes the Pierce oscillator wide in frequency response so that it may be used with various crystals covering a large range; for greater activity and output where wide response is not a factor, R_2 should be replaced by an r-f choke of the inductance required for the particular frequency.

Some modern adaptations of the Pierce crystal oscillator are discussed and illustrated in the paragraphs which follow.

31. Practical Triode Pierce Circuit

The Pierce modification in Fig. 27 differs from the basic circuit in several details: the grid capacitor ($C1$) is variable so that the amount of crystal excitation may be adjusted for optimum operation; a small amount of safety bias is introduced by the voltage drop across $R2$ and the consequent d-c charge in $C3$; and the crystal is coupled to the plate via $C2$ (.01 mfd) rather than being directly connected from grid to plate. This capacitor serves a double purpose in this case because it removes d-c from the crystal holder and enables the output of the oscillator to be coupled to the next stage without additional capacitance. The 2.5-mh r-f choke used as a load impedance in this oscillator improves the output but limits the oscillator to a narrower range of crystal frequencies. This particular circuit is used as a master oscillator in a transmitter designed to cover the range between 2000 and 4000 kc; thus, the width of its coverage is sufficiently small to permit the use of the r-f choke rather than a load resistor.

32. Screen-grid Pierce Oscillator

The oscillator given in Fig. 28 is typical of many master oscillators being used in specialized military equipment on the lower radio frequencies. The Pierce circuitry is evident upon inspection of the schematic, the departures from the fundamental arrangement being due largely to the use of a screen grid tube rather than a triode.

Fig. 27. Modified Pierce oscillator circuit.

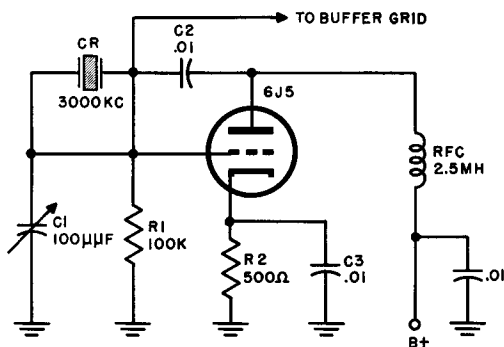

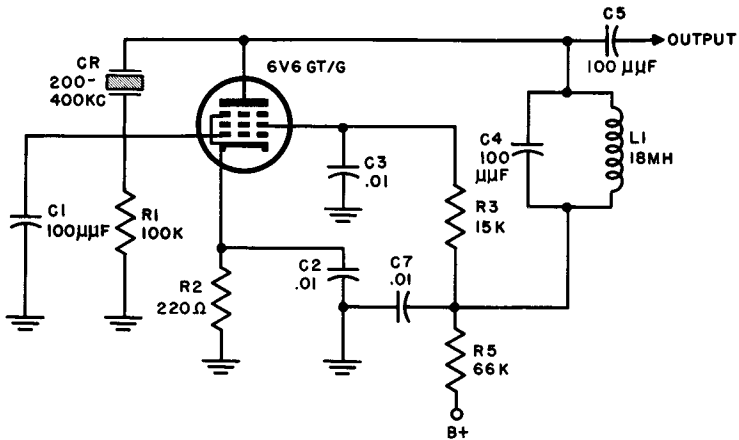

Fig. 28. Screen grid Pierce oscillator circuit.

The additional components are: C_3 , a capacitor that keeps the screen grid at r-f ground potential; R_3 , a screen dropping resistor to bring the voltage to the rated value for this tube; R_5 and C_7 , a decoupling network intended to isolate the oscillator from other stages operated by the same power supply; and the nonadjustable tank circuit comprising C_4 and L_1 , chosen to offer a relatively high impedance over the range of 200 to 400 kc. At these low frequencies a parallel resonant circuit used as a plate load is a more effective method of obtaining a high plate impedance than an r-f choke or a resistor.

33. Electron-Coupled Crystal Oscillator

The electron-coupled crystal oscillator shown in Fig. 29 is an adaptation of the grounded-plate Colpitts circuit to crystal control and electron-coupling, with the crystal replacing the untapped Colpitts tuning inductance. Capacitor C_3 effectively grounds the screen grid and, since this electrode serves as the plate of the oscillator, it may be referred to as a grounded-plate circuit. The amount of crystal excitation is a function of the ratio C_1/C_2 , C_1 being made variable so that the excitation may be adjusted for best performance.

Fig. 29. Colpitts crystal oscillator circuit in electron-coupled form.

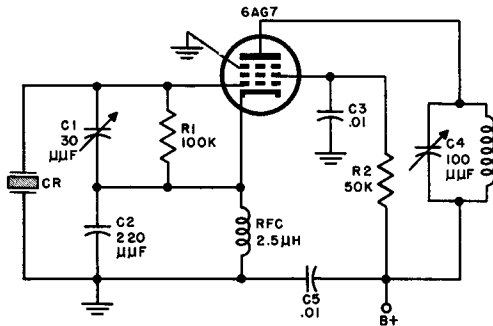

It is desirable always to ground one of the crystal electrodes. But, if that is done in this particular circuit, the ground must be moved from the cathode, which then must operate at r-f potential above ground. An additional component—the r-f choke—must be connected between the cathode and ground to provide a d-c return path to the cathode for the plate current, without short-circuiting the cathode to ground for r-f. It may be observed by referring to Fig. 26 (A) that an r-f choke is unnecessary if the cathode is grounded, but under the circumstances shown in Fig. 29, the d-c plate path must be completed by a device having high r-f impedance, hence the use of the choke.

The 6AG7 is an excellently shielded tube, internally; this makes for minimum reaction between output and input circuits and lends greater stability to the crystal oscillator. In this circuit again, the electron stream is modulated by the oscillation frequency and the plate circuit is, therefore, electron coupled to the oscillatory section.

34. Review Questions

1. What single major factor of circuit design determines the selection of a parallel resonant or series resonant crystal oscillator?
2. Draw a circuit of a standard Miller oscillator using a 6J5GT. Assign values to the component parts and explain the purpose of each component in the diagram.
3. What advantages might be gained by replacing the triode of question 2 with a pentode? Are any other circuit modifications necessary?

4. Draw a typical circuit for the "Pierce" crystal oscillator.
5. Give the equivalent circuit for the diagram above.
6. Draw the electron coupled Miller oscillator and explain its operation.
7. Why is grid capacitor $C1$ of Fig. 27 variable?
8. What are the *two* functions of $C2$ in Fig. 27?
9. Draw the diagram of an electron-coupled crystal oscillator and explain its operation.
10. In the diagram of question 9 an r-f choke is usually inserted between cathode and ground. Explain why this is necessary.

Chapter 5

HARMONIC AND OVERTONE CRYSTAL OSCILLATOR CIRCUITS

35. Harmonic and Overtone Operation

The use of the terms “harmonic” and “overtone” often leads to confusion because, as nearly synonymous as these expressions may be, their connotations are often vastly different. Since both terms refer to multiples of fundamental frequencies, it is advisable to distinguish between them as they are to be applied in this chapter.

Harmonic operation of a crystal oscillator occurs in a circuit in which the crystal vibrates in its *fundamental mode*. Harmonics of the fundamental frequency are obtained by tuning—usually in the output circuit—to multiples of the crystal frequency.

Overtone operation occurs in a crystal that oscillates in one of its *overtone modes* rather than at its fundamental frequency. Harmonic output from such oscillators is realized by amplifying the crystal’s overtone oscillation directly. There is no fundamental-frequency signal present in such an oscillator.

For a great many years, crystal control at frequencies above 20 mc could be accomplished only by utilizing one or more cascaded frequency multipliers, with the attendant problems of removing unwanted harmonic frequency components. The first steps toward the elimination of the problem came in the form of harmonic oscillator circuits such as the famous tri-tet crystal oscillator; later, other electron-coupled harmonic oscillators made their appearance on the scene and their use became quite common.

The introduction of overtone crystals, however, marks the inception of very high frequency crystal control. For example, a crystal-controlled amateur transmitter on 144 mc might use a crystal marked "24 mc"; the output of the crystal oscillator might then be doubled to 48 mc, then tripled to 144 mc and used to drive a high power 144-mc final class C amplifier. Such a 24-mc crystal is really an 8-mc *AT* cut specially "treated" for overtone characteristics so that it oscillates freely on its third harmonic mode.

It should be pointed out that the frequency of a crystal's oscillation at an overtone mode may not be an exact multiple of the frequency of the same crystal's oscillation at its fundamental frequency. The physical "breakup" of the crystal for overtone vibration is not always into exactly equal parts. Accordingly, a crystal accurately ground for a fundamental frequency cannot be expected to be accurately ground for an overtone frequency. Crystals to be operated on overtone frequency should be ground by the manufacturer for the overtone to be used, and the overtone frequency specified. These crystals may also be used on their fundamental frequency, but this fundamental frequency will not usually be exactly the overtone frequency divided by a whole number.

The paragraphs immediately following deal with harmonic oscillators of the tri-tet type; those toward the close of the chapter are concerned with overtone operation.

36. Fundamental Tri-Tet Circuitry

The name "tri-tet," derived from *triode-tetrode*, implies that the oscillator tube behaves as a triode (screen acting as oscillator plate) and as a tetrode (plate acting as output electrode) simultaneously. Since many of the circuits previously discussed also follow this pattern, a further qualification must be added to differentiate these from the conventional tri-tet. The tri-tet designation is used to describe oscillator circuits in which the output plate tank *is in series with* the oscillatory tank, with the tube between the two (Fig. 30). The *L1-C1* combination may be visualized as the generator of r-f energy, because it is the oscillatory tank. The cathode-to-plate path within the tube and the output tank *L2C2* are all in series with it as shown in Fig. 30 (B).

Tri-tet frequency stability is measurably lower than that of conventional pentode circuits because of the large stray capacitance that directly shunts the crystal unit. The stray capacitance comes to about $8 \mu\mu\text{f}$ in the average circuit. About $4 \mu\mu\text{f}$ of this is due to the capacitance between the control grid and the screen grid and another $4 \mu\mu\text{f}$ is due to the capacitance of the grid leads to ground, which otherwise would be part of C_p .

As in other harmonic generators, high harmonic output is obtainable only when the plate current is cut off for a large part of the cycle, making for greater distortion and richer harmonic content. If the frequency is being doubled, plate current should flow for about $\frac{1}{4}$ of the time; if it is being tripled, plate current should flow for approximately $\frac{1}{6}$ of the time. To generalize, if the frequency is to be multiplied n times, optimum n th harmonic output is approached if the oscillator is designed so that the tube conducts for approximately $\frac{1}{2} n$ of each fundamental cycle.

37. A Practical Miller Tri-Tet Oscillator

The circuit pictured in Fig. 31 was designed for use with a crystal on or about 3.0 mc. It is essentially the same as the basic circuit in Fig. 30, differing only in a few details.

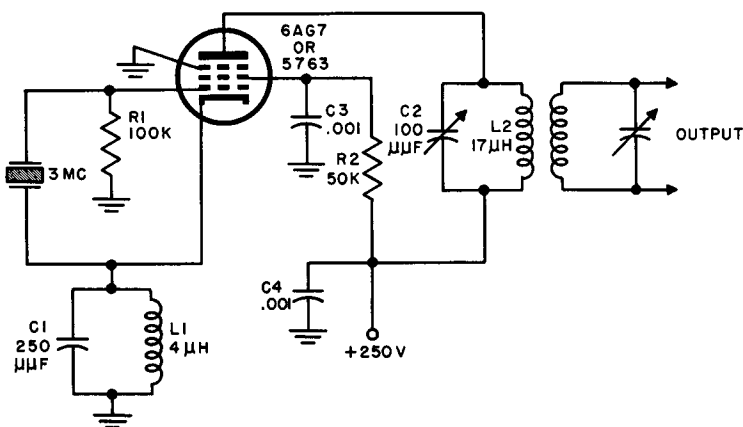

Fig. 31. Miller tri-tet oscillator.

A tube such as the 6AG7 is recommended for a circuit of this type because of its good internal screening, although other tubes having similar characteristics can be made to perform satisfactorily. Grid resistor $R1$ is, in this case, returned to ground rather than to the cathode for a more convenient wiring layout; it should be noted, too, that the suppressor grid in the 6AG7 or 5763 is externally connected to ground rather than to cathode, and that the cathode tank circuit has a low L/C ratio as called for by proper design.

Such an oscillator is suitable for use as the crystal driver for a multi-stage transmitter, as a calibration oscillator, or in any application where strong, stable harmonic output is desired.

38. A Practical Pierce Tri-Tet Oscillator

The type of oscillator with which one is dealing is not always evident from a cursory inspection of the schematic diagram. For those who are interested in naming the circuit under study—and this is often very difficult because of the multitude of modifications that may be made in the fundamental design—a rule that is usually (though not always) safe for differentiating between Pierce and Miller circuits is this: if one end of the crystal is at the same radio-frequency potential as the plate (or screen in electron-coupled oscillators) the circuit is probably a Pierce; if one end of the crystal is at the same radio-frequency potential as the cathode, it is probably a Miller Oscillator.

This point is made here because a casual glance at the circuit of Fig. 32 would seem to give the impression that it is a Miller modification until one recognizes that the bottom of the crystal does not return to cathode potential. In the circuit given in this figure, excitation is controlled by means of $C1$; the cathode tank circuit consists of the r-f choke and $C3$; the bottom of the crystal is returned to the screen (making it a Pierce circuit, as explained previously) through $C4$; and the plate tank circuit is tuned to the second harmonic of the crystal frequency. This Pierce tri-tet oscillator is used as a crystal calibrator in Frequency Meter TS-186/UP, and is furnished with a 5-mc crystal.

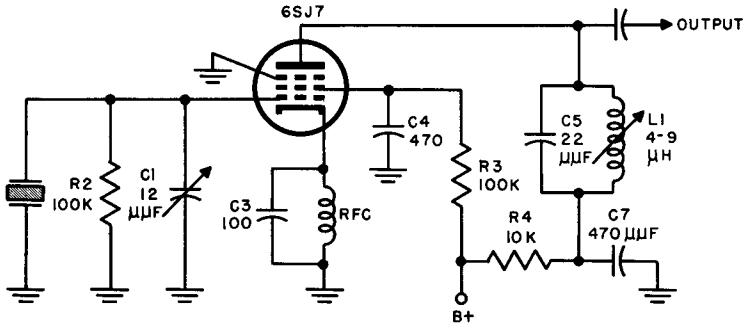

Fig. 32. Pierce tri-tet oscillator circuit.

39. Series-Mode Oscillation

In general, crystals show definite response characteristics at two distinct frequencies; the series resonant frequency (f_r) and the anti-resonant frequency (f_a) as described in Par. 10 and illustrated in Fig. 7. All of the oscillators discussed thus far are typical of *parallel resonant* circuits for which the operating frequency lies somewhere between f_r and f_a . This requires further clarification.

Although an oscillator may depend upon a crystal operating at its series-resonant frequency (f_r) as will be shown in subsequent paragraphs, it is not practicable for a crystal unit to control an oscillator at the anti-resonant frequency (f_a). Although it would seem that the conditions for parallel resonance are best met at the anti-resonant frequency of the crystal, because it is at this point that the impedance of the crystal unit is maximum and is thus extremely sensitive to frequency changes, consideration of the circuit as a whole shows at once that such an assumption is incorrect. The input of the vacuum tube shunts the crystal unit; this shunt circuit has a much lower impedance than that of the crystal at anti-resonance so that the *total* impedance will be relatively insensitive to small frequency variations in the region of f_a .

In practice, the actual frequency of Pierce, Miller, and other parallel-resonant crystal oscillators lies between f_r and f_a to take advantage of the steep slope between these two frequencies (Fig. 7). In this region the crystal unit is still very sensitive to small fre-

quency changes, but its impedance is much lower than at anti-resonance, hence the effect of the shunt circuit is not as severe.

With the introduction of overtone crystals, series-mode operation (operation at series resonance) becomes more widely used because of its excellent frequency stability characteristics. At series resonance, the crystal element appears as a very small resistance, so that in the normal circuit it can be short-circuited or replaced by a comparable resistance without stopping oscillations. Quite often, satisfactory control is obtained simply by designing a conventional variable-tuned oscillator to operate at the desired frequency, and then inserting the crystal unit in a plate tank or feedback circuit. Over a very definite range of adjustments, the crystal can assume control and hold the frequency nearly constant. However, a number of special oscillator circuits have been designed specifically for series-mode operation and, most often in new equipment planning, one of these is utilized if overtone operation is contemplated.

Although the scope of this book does not permit discussion of all the various types of series-mode oscillator, the recommended designs are given below for future reference or most extensive reading: Meacham Bridge, Capacitance Bridge, Butler, Grounded Cathode, Grounded Grid, Grounded Plate, Transitron, Impedance-Inverting Pierce and Miller, Two-Stage Feedback, and Modified Colpitts.

40. The Butler Oscillator

At the time of writing, probably the most widely used of the series-mode oscillators is the Butler cathode-coupled two-stage oscillator. Its popularity is attributable to its simplicity, versatility, frequency stability, and reliability. Especially with older overtone crystals, it was generally found that the Butler circuit was least critical to design and to adjust for operation of the crystal at a given harmonic. The balanced arrangement of the circuit and the fact that twin triodes are common and inexpensive contribute to the economy of its construction and to short lead design.

The basic Butler oscillator is illustrated in Fig. 33. $V1$ is a cathode follower, which is coupled to the grounded-grid amplifier, $V2$, through the crystal unit. The resonant circuit, C_oL_o , is tuned to

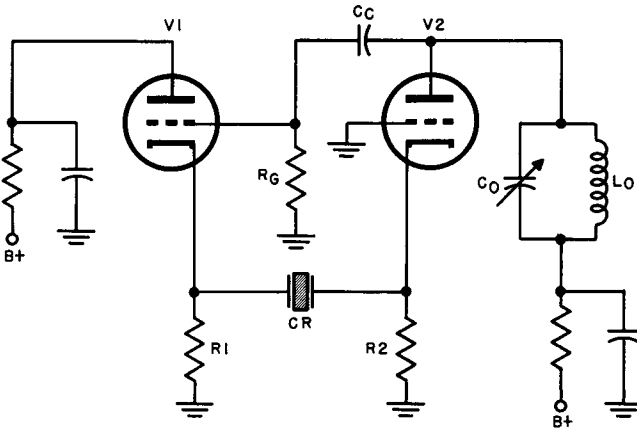

Fig. 33. Basic Butler type overtone oscillator circuit

the desired overtone of the crystal and, when power is applied, produces a transient oscillation, which is applied as a voltage to the grid of $V1$. At series resonance, the resistance of the crystal is low, so that the voltage drop across $R1$ due to the coupled oscillation is fed back with little loss to the cathode of $V2$, thus maintaining oscillation. At any frequency other than that of the overtone of the series-resonant frequency, the crystal presents a high impedance to the flow of feedback current (See Fig. 7) preventing the loop from compensating for circuit losses. Thus, when oscillation does occur it is at the frequency of the crystal overtone and no other.

Should the crystal be shorted out, the crystal would still oscillate at a frequency governed by the values of C_0 and L_0 because in this circuit, the crystal behaves as a series resistance of very low value. The control value of the crystal lies, of course, in the fact that it has this low resistance only at its series resonant frequencies, and therefore permits sustained oscillations only at f_r or its overtones.

41. Design Considerations for Butler Overtone Oscillators

If an oscillator is to operate below 20 mc, the Butler circuit has little advantage over the simpler Pierce or Miller. At the higher fre-

quencies, however, it will be found that the Butler oscillator has the advantage of ease of adjustment and dependability.

In selecting the vacuum tube, space and weight considerations suggest the use of a twin-triode or twin-pentode unless a more balanced arrangement is possible with separate tubes. The transconductances of $V1$ and $V2$ should be as high as possible for maximum frequency stability.

If the oscillator is to operate in Class A, both tubes may be of the same type; for Class C operation, however, the power rating of the cathode follower should be greater than that of the grounded-grid amplifier, a condition that usually requires the use of separate tubes. If it is desirable to isolate the load from the oscillator, a pentode may be used in an electron-coupled circuit for $V1$ (Fig. 34), with the screen serving as the plate of the oscillator.

In the vhf range triodes may be preferable because of their smaller transit-time effects. To reduce transit time to a minimum, the plate voltages should be as high as practicable; in addition, the use of high plate voltage raises the transconductance and hence the stability of the system.

The electron-coupled circuit of Fig. 34 is similar to that of the basic Butler circuit except for the presence of the second tuned circuit, LC . The screen of $V1$ is the plate of the oscillator while the output is taken from the plate of the tube. LC is tuned to the desired crystal overtone but has little loading effect, and consequently

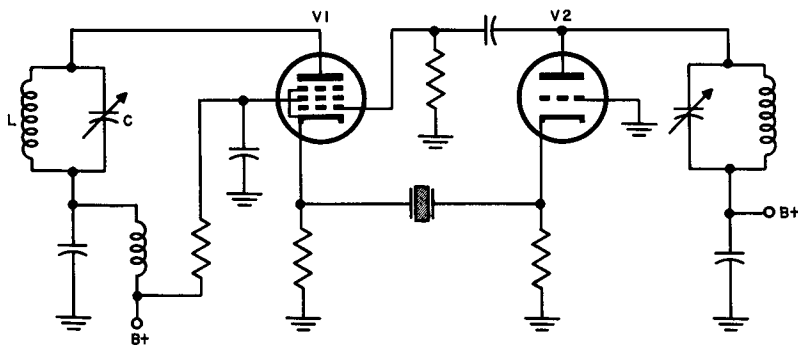

Fig. 34. Electron-coupled Butler oscillator circuit.

helps maintain the frequency constant even when the load varies within limits.

42. Capacitance-Bridge Series-Mode Crystal Oscillator

A bridge of any kind is essentially an arrangement in which a balanced condition is established through proper choice of resistive, capacitive, and inductive components. In the bridge circuit of Fig. 35, meter M reads zero when the bridge is in balance, because the potentials at points A and B are the same, equal voltage drops having occurred across the bridge arm components. Under these conditions, the component relationship is: $C2/C1=L1/L2$.

Consider now the effect of substituting a crystal unit for $C2$. At a frequency removed from the series-resonant frequency, the crystal unit simply behaves as a capacitor; hence the conditions are essentially identical to those which obtain if this arm contains an ordinary capacitor *except at the resonant frequency*. When f_r is reached, the crystal unit becomes purely resistive, thus completely upsetting the bridge balance. Thus, a bridge of this variety may be balanced for all frequencies above and below the crystal frequency (within rather wide limits) by means of a single adjustment, but at the crystal frequency it will be unbalanced.

By adding another capacitor as shown in Fig. 36 (A) the bridge may be used as a tank circuit without affecting its balancing function. Figure 36 (B) illustrates the same arrangement redrawn to clarify the designation of tank circuit. $C3$ is now the tuning capacitor, while $C1$ retains its ability to balance the bridge.

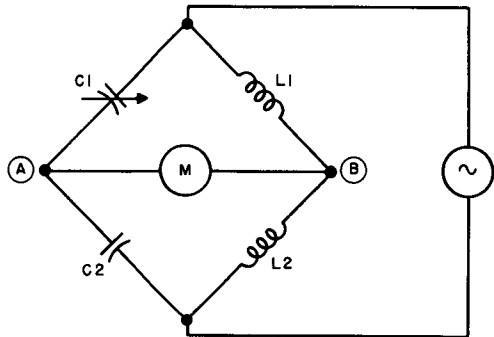

Fig. 35. Basic capacitance bridge circuit.

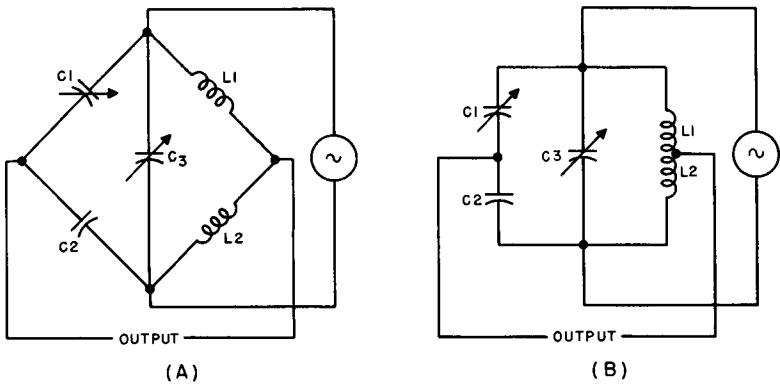

Fig. 36. (A) Capacitance bridge circuit and (B) its form as a tank circuit.

Figure 37 is a drawing of this bridge circuit connected to form a crystal-controlled oscillator. $L1$ and $L2$, in this case, are actually a single, tapped inductance with the two sides wound on the same form and tightly coupled together. The induced-voltage effect is equivalent to that of a single generator connected across both coils (as in Figs. 35 and 36) and driving the bridge with an emf that is roughly equal to the voltage across $L1$ multiplied by the turns ratio plus one. That is, driving emf = $E1 (T. R. + 1)$. The turns ratio is usually and most conveniently made equal to 1 so that the inductance may be center-tapped.

As long as the bridge is in balance as a result of prior adjustment, oscillation cannot take place, because the voltage applied be-

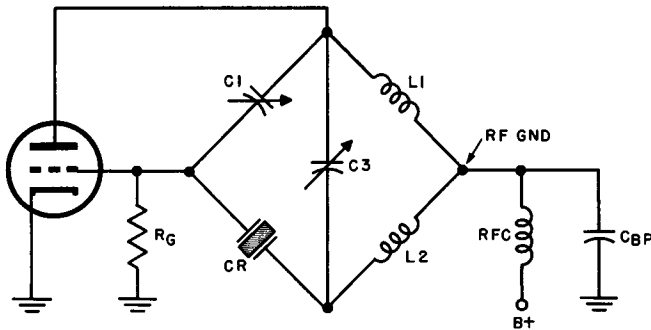

Fig. 37. Basic capacitance bridge oscillator circuit.

tween grid and ground must be zero. Therefore, before the oscillator is put to work, the bridge is balanced with $C1$, using a signal from an external generator of some frequency either above or below the crystal f_r . For this balancing adjustment, the capacitance of $C3$ is reduced to minimum, then $C3$ is slowly meshed and, at some point, oscillations suddenly start. This is the point where f_r has been closely approached, so that the crystal behaves as a resistor instead of a capacitor, throwing the bridge off balance. When this occurs, voltage appears between grid and ground at the crystal frequency and the circuit is then capable of sustaining oscillations. As in other series-mode oscillators, the frequency to which the tank circuit is tuned may be that of one of the crystal overtones or that particular overtone specified by the manufacturer on the crystal unit.

43. A 50- to 90-Mc Capacitance Bridge Oscillator

The capacitance-bridge oscillator shown in Fig. 38 has been operated at frequencies as high as 135 mc but its particular merit lies in its performance at frequencies between 50 mc and 90 mc. Values for all the components except $L1$ and $L2$ are given in the

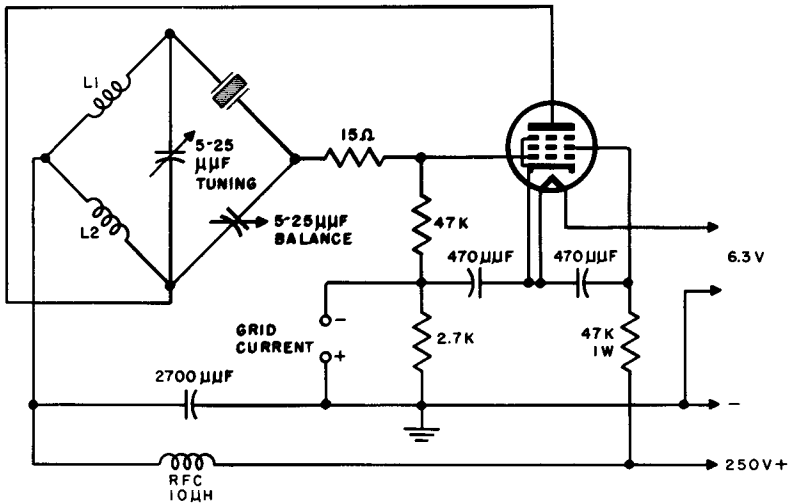

Fig. 38. Capacitance bridge oscillator circuit particularly designed for use in the 50-90 mc frequency range.

schematic diagram; the coils are made up of a single center-tapped inductance whose magnitude must be determined by calculation for a particular crystal unit. Provision is made for measuring grid current to determine optimum operating adjustments. *R1* is inserted to prevent momentary crystal overdrive during the tuning process. In all other respects, the circuit functions as described in the preceding paragraph.

44. Other Series-Mode Oscillators

Space prohibits an extended discussion of the other kinds of series-mode oscillators mentioned in Par. 35. It is felt, however, that the reader may be interested in a tabular comparison of these with respect to specific features. Table 3 is a condensation of authoritative research information of recent years compiled by the United States Department of Commerce. It should be realized that the ratings for the different oscillators are based on average qualitative results reported by qualified investigators but that any rating may vary in individual cases.

45. Review Questions

1. Distinguish between the terms "harmonic operation" and "overtone operation."
2. Draw the circuit of a fundamental tri-tet oscillator.
What does the name tri-tet refer to?
3. Explain the circuit operation and the principal advantages of the tri-tet crystal oscillator.
4. Sketch a practical Miller tri-tet oscillator employing a 6AG7 tube. Compare your drawing with Fig. 31 and explain the function of grid resistor *R1*.
5. How does Fig. 32 differ from the circuit of question 4?
6. Explain the operation of the crystal element in series-mode oscillation at the resonant frequency.
7. Draw the circuit of the Butler cathode-coupled two-stage oscillator.
8. Explain the circuit operation of the Butler oscillator.
9. Refer to Fig. 37, and explain the operation of the capacitance-bridge series-mode oscillator.
10. In what respects do the circuits of Figs. 37 and 38 differ?

TABLE 3

RATINGS FOR SERIES-MODE OSCILLATORS

A—Meacham Bridge
 B—Capacitance Bridge
 C—Butler
 D—Grounded Grid,
 Transformer Coupled
 E—Transitron
 F—Impedance Inverting
 Miller
 G—Impedance Inverting
 Pierce
 H—Modified Colpitts

(1 is highest rating, 7 is lowest rating)

	A	B	C	D	E	F	G	H
Frequency								
Stability*	0.0001	0.002	0.0005	0.0004	0.0004	0.002	0.0015	0.0015
Power								
Output	6	5	3	3	4	2	4	3
Versatility	4	4	2	2	2	3	3	3
Upper								
Frequency								
Level	5	1	3	2	2	3	3	3
Ease of Ad-								
justment	6	7	1	2	2	5	5	5
Frequency								
Multi-								
plication	5	5	2	4	5	3	3	6
Circuit								
Simplicity	4	5	3	1	2	3	3	4
Isolation from								
Load	1	2	3	4	4	4	4	4
Low								
Frequency								
Operation	1	6	3	5	2	4	4	2
Low								
Harmonic								
Output	1	2	2	5	5	4	4	2

* In percent, oven controlled.

INDEX

- Acoustic radiation, 15
- Adjustments, self-excited oscillator, 4
- Air gap mount, 32
- Angular rotation, crystal axes, 23, 24, 25
- Anti-resonant frequency, crystal, 13
- AT-cut crystals, 29
- Average plate efficiency,
 - crystal oscillator, 18
- Axes, crystal, 7, 8
- Axes, electrical, 8
- Axes, mechanical, 8
- Axes, optical, 8

- Baffle, oven, 36
- Bias, 13, 15
- BT-cut crystals, 29
- Butler oscillator, 53
- Butler oscillator, electron coupled, 55
- Butler overtone oscillator, design, 54
- Button mounts, 33, 34

- Capacitance-Bridge oscillator, basic, 56, 57
- Capacitance-bridge oscillator, practical, 58
- Caps, crystal, 7
- Cathode bias, 16
- Circuit classification, crystal oscillator, 38
- Class A operation, Butler oscillator, 55
- Class C operation, Butler oscillator, 55
- Colpitts oscillator, 42
- Compliance, mechanical, 14
- Compressional mode, 9
- Continuous frequency coverage, oscillator, 3
- Crystal cut, chronology, 21, 22
- Crystal fuse, 20
- Crystal heating, 18
- Crystals, piezo-electric, 6
- CT-cut crystals, 29

- Dielectric sandwich, 33
- Distortion, crystal, 12
- DT-cut crystals, 29

- Electrical stress, in crystal, 6
- Electron-coupled, crystal oscillator, 38
- Electron-coupled oscillator, crystal, 44, 45
- Equivalent circuit, crystal oscillator, 13, 14
- Equivalent inductive reactance, 14

- Faces, crystal, 8
- Fixed bias, 15
- Flexure mode, 9
- Frequency equation, 4
- Frequency factor, 28, 30
- Frequency factors, popular cuts, 30
- Frequency-impedance curve, 13
- Frequency stability, oscillator, 2
- Frequency stability, tri-tet, 50
- Fundamental tone, strings, 9

- Grid current, crystal oscillator, 13
- Grid leak bias, 16, 17
- Grid meter, use of, 19
- Grid-plate capacitance, 13
- GT-cut crystals, 29

- Harmonic operation, 47
- Harmonics, 9

- IRE system of specification, 24, 25, 26

- Longitudinal mode, 9
- Loose coupling, crystal circuits, 18

- Mass, vibrating, 14
- Mechanical resonance, 8
- Miller oscillator, basic, 11
- Miller oscillator, electron coupled, 41
- Miller oscillator, screen grid tube, 39, 40
- Miller oscillator, standard, 38, 39
- Modes of vibration, 8
- Modulated stream, electron coupled oscillator, 41
- Mother stone, crystal, 6
- Mounts, crystal, 31, 32, 33, 34, 35

- Operating temperature, oven, 37
- Orientation, meaning of, 21
- Oscillation, 1
- Oscillator, applications, 2
- Oscillator, crystal-controlled, general, 5
- Oscillator, L-C characteristics, 3
- Oscillators, performance requirements, 2
- Oscillators, self-excited, 4
- Oven, crystal, 21, 36, 37
- Overtone operation, 47
- Overtones, strings, 9

- Parallel resonant, crystal oscillator, 38
- Parallel resonant frequency, 52
- Pictorial method, orientation
 - specification, 23
- Pierce oscillator, fundamental circuit, 41, 42
- Pierce oscillator, practical circuit, 43
- Pierce oscillator, screen grid tube, 43, 44
- Piezo-electric effect, 6
- Plate, crystal, 6
- Plated crystals, 34
- Popular cut orientation, 28
- Positive feedback, 11
- Power output, crystal oscillators, 5, 18
- Power output, oscillator, 2, 3
- Pressure sandwich mount, 32

- Q of crystal, 15
- Quartz crystal, 6

- Resonance, mechanical, 8
- Rochelle salts crystal, 6
- Ruggedness, oscillator, 3

- Self-regulation, 17
- Self-starting oscillation, 17
- Series-Mode oscillation, 52
- Series-Mode oscillators, 59
- Series-Mode oscillators,
 - design rating chart, 60

- Series resonant, crystal oscillator, 38
- Series resonant frequency, 52
- Shear mode, 9
- Shock excitation, 11
- Simplicity of operation, oscillator, 3
- Summary, advantages and
 - disadvantages of various cuts, 30, 31

- Tank circuit, 3
- Temperature coefficient, 22
- Temperature coefficient problems, 22, 23
- Thermal key, 36
- Thermostats, oven, 36
- Torsional mode, 10
- Tourmaline crystal, 6
- TPTG Oscillator, 11, 12
- Tri-tet circuitry, fundamental, 48
- Tri-tet Miller circuit, 50
- Tri-tet Pierce circuit, 51
- Tuning, crystal oscillator basic, 18

- V-cut crystal, 21

- Wire mounting, 34, 35

- X-cut crystals, 28

- Y-cut crystals, 28