

on  
D-C. VOLTAGE DISTRIBUTION  
in  
RADIO RECEIVERS

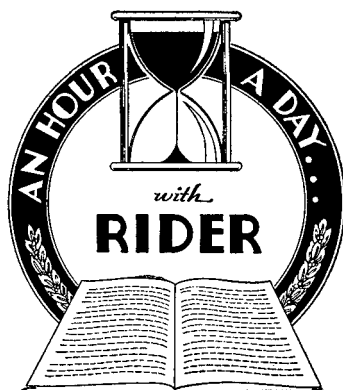

ON  
D-C. Voltage Distribution  
IN  
Radio Receivers

*Published by*

**JOHN F. RIDER, Publisher**

1440 BROADWAY

NEW YORK CITY

Copyright 1936, by  
JOHN F. RIDER

---

*All rights reserved, including that of translation  
into the Scandinavian and other  
foreign languages*

*Printed in the United States of America*

## TABLE OF CONTENTS

- CHAPTER I. GENERAL REVIEW**—1. Matter and Molecules—1. Atoms and Electrons—2. Electric Current—3. Electron and Electric Current Polarity—5. Direct or Continuous Current—6. Conductivity and Resistance—6. Temperature Coefficient—9. Unit of Resistance—Ohm—10. Unit of Current—Ampere—11. Unit of Potential—Volt—12. Ohm's Law—13. Power Rating of Resistances—17. Conversion Tables—20.
- CHAPTER II. SERIES CIRCUITS**—23. Resistances in Series—26. Voltage Drop—28. Polarity of Voltage Drop—34. Variation in Polarity with Ground—38. Internal Resistance and Internal IR Drop—38.
- CHAPTER III. PRACTICAL APPLICATIONS OF SERIES CIRCUITS**—40. Plate Circuits—40. Plate Circuit Measurements—46. Bias Circuits—50.
- CHAPTER IV. PARALLEL AND SERIES-PARALLEL CIRCUITS**—69. Polarity of Voltage Drop in Parallel Circuits—76. Series-Parallel Circuits—76.
- CHAPTER V. PRACTICAL APPLICATIONS OF PARALLEL AND SERIES-PARALLEL CIRCUITS**—80. Voltage Dividers—88.

## Chapter I

### GENERAL REVIEW

MORE than likely you have heard the question asked, "What is electricity?" . . . Well,—electricity is the electron and electric current is the electron in motion. This explanation is simple and consists of but a few words. However, we cannot rest there, because the term "electron" has been introduced and while it is not our idea to devote a great deal of time or space to the discussion of the electron theory—there are certain facts appertaining thereto—meager as they may be—which you may want to know. . . . As a matter of fact this information may serve as a sort of background for what follows:

#### Matter and Molecules

Speaking in generalities, Matter is anything which has weight and consequently is acted upon by gravity. Irrespective of the nature of Matter, whether a solid, a gas, or a liquid, invisible or visible, it is made up of extremely small particles called "molecules." Molecules are the smallest integral particles of Matter and are individual and separate from each other in the particular kinds of Matter which they comprise. If we are talking about a gas, the gas is made up of molecules of that gas. If we are talking about a solid, such as wood, it is said that the wood is made up of molecules of wood. If we are talking about a liquid, such as water, it would then be said that the water is comprised of molecules of water.

### Atoms and Electrons

While it is true that the molecule is the smallest integral particle of Matter—it too is a structure and in turn consists of smaller particles known as “atoms.” There are as many kinds of atoms as there are kinds of basic chemical elements. Various combinations of these atoms comprise the various kinds of molecules. For example, a molecule of water consists of two atoms of the basic chemical element hydrogen and one atom of the basic chemical element oxygen. A molecule of sulphuric acid, on the other hand, consists of two atoms of the basic element hydrogen, one atom of the basic element sulphur, and four atoms of the basic element oxygen. Other kinds of molecules consist of other atomic combinations of the basic chemical elements.

In accordance with accepted theory, although not the most modern theory, the atom consists of two parts,—as it happens, electrical parts. One of these is electrically positive and is known as the “proton”; the other is electrically negative and is known as the “electron.”

The different kinds of atoms are identified by the number of protons and electrons contained within them. Inasmuch as a normal atom is electrically neutral, that is, the positive and negative charges are alike in magnitude, it is assumed that the number of electrons and protons are alike in any one kind of atom, but differ in different kinds of atoms. For example, the simplest atomic structure is the hydrogen atom, in which there is one proton and one electron and the nucleus of this atom is the single proton or unit positive charge. In some other kinds of atoms there may be five protons and five electrons. In a third kind of atom there may be twenty-six protons and twenty-six electrons—and so on. Note that in each case the number of electrons or negative charges is the same as the number of protons or positive charges.

Another item of interest is the fact that the arrangement of the positive charges and the negative charges is not always the same. The nucleus always contains all of the positive charges—but in some kinds of atoms it also contains some of the electrons. The electrons present in a normal atom, but which are not a part

of the nucleus, revolve around this nucleus in a number of different orbits like the various planets around the sun. In some atoms all of the electrons revolve around the nucleus, whereas in other atoms, only a few electrons are planetary—that is, revolve around the nucleus.

The power of attraction between the nucleus and the planetary electrons is not the same in all atoms. Certain kinds of atoms will part freely with one or more of the planetary electrons, whereas other atoms will hold on to these planetary electrons. All materials, which conduct electric current very readily, are made up of atoms which will part easily with one or more electrons—whereas materials, which are poor conductors of electricity and are classified as insulators, are composed of atoms which do not readily part with their planetary electrons. This relation between various kinds of electrical conductors, and the ease with which an atom will part with one or more electrons is important, inasmuch as the electric current is these electrons in motion.

### **Electric Current**

Electric current, which is flowing through a conductor, is nothing more than a definitely directed drift of electrons through the conductor. If you apply a voltage across the terminals of a substance wherein the atoms retain a very powerful influence upon the planetary electrons, so that these electrons are not abundantly freed from the atoms—there will be a very small current flow through that material.

Electrical conductors, as a rule, are made up of densely packed atoms, and these atoms are in a state of continual agitation. This internal thermal agitation exists without any external voltage being applied. The normal consequence of such agitation is that collisions occur between the atoms and planetary electrons are dislodged from electrically neutral atoms. These dislodged electrons drift in a slow haphazard fashion through the conductor—sometimes attracted to atoms which have lost an electron and now bear a preponderance of positive charges—sometimes repelled by atoms to which has become attached an extra electron, so that the atom displays a preponderance of

negative charges. Supplementary to this—there are in all materials free electrons not bound to any particular atom and which drift and bounce through the conductor.

Such electron action takes place in all materials to a varied degree. In some the wandering electrons are more plentiful, and in others they are very scarce. However, irrespective of the abundance of electrons in a material, all electrons are the same no matter what the type of atom. *All electrons bear negative charges and all are carriers of the same amount of electricity.*

When a voltage is applied to such a conductor, the general drift of these moving or wandering electrons is directed in a certain, definite direction. The electrons, which normally move through the circuit, do not necessarily move in a straight path. They wander around, but under the influence of an applied voltage will move or drift in the direction of the voltage—namely, from the negative to the positive direction. An idea of what has been said can be had by referring to Fig. 1. The

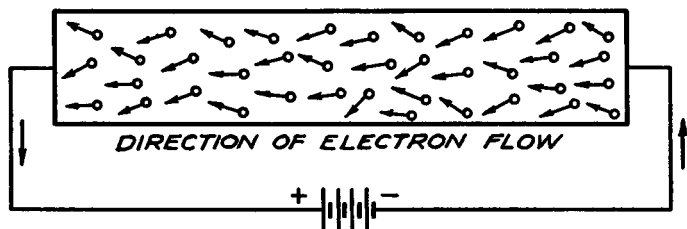

*Fig. 1. The general drift of electrons is from minus to plus, but their movements are erratic, as indicated by the different directions in which the arrows point.*

arrows attached to each of the circles all point in the general direction towards the positive side of the circuit, but at the same time they indicate a haphazard direction of the individual electron's movements.

The moving or drifting electrons constitute the electric current. Contrary to general conception, use of the word "drift" is quite proper, because the speed at which electrons move through a conductor is quite slow. The actual amount of electricity represented by an electron is infinitesimally small, so that a great number of electrons must move through a circuit in order



to be representative of reasonable amounts of current, such as are experienced in modern radio circuits. An idea of the small amount of electricity carried by an electron, or represented by an electron, and the large number of electrons, which must pass a certain point in order to equal 1 ampere of current, can be had by conceiving, if such is possible, the movement of the staggering sum of 6,280,000,000,000,000 electrons past a point in one second. Fortunately for us, we work with conveniently chosen units of electric current rather than in quantities of electrons, so that the figures involved in the circuit are comparatively simple.

### Electron and Electric Current Polarity

Now we come to a very peculiar condition existent in the realm of electricity. We have made the statement—and it is a generally accepted fact—that electron flow is from minus to plus or from the minus end of the circuit to the plus end of the circuit. *In other words, the positive charge is at the higher potential and attracts the negative charge, which is the electron. . . . However, the accepted convention of the direction of electric current flow is opposite to the direction of electron flow. . . . In an electric circuit we assume that the direction of current flow is from the positive side to the negative side—or from + to —.* When speaking about electron flow, we say that the positive charges attract the negative charges. . . . When speaking about electric currents—we say that the current *flows away from the positive side . . .* and at the same time the positive side of the circuit is the higher potential side.

From the practical angle, in most cases, we can neglect the direction of electron flow. As far as the subject matter of this book is concerned, it is not necessary for us to consider the movement of electrons when speaking of the electric current in the circuit. We speak of electric current and its direction of flow or polarity without concerning ourselves with what it is.

Fig. 2 illustrates pictorially the difference between the direction of electron flow and the accepted convention of electric current flow. As far as you are concerned in the practical determination of the polarity of different points along an electri-

cal circuit, consider electric current as flowing from the most positive end of the circuit to the most negative end. So much of that for the present.

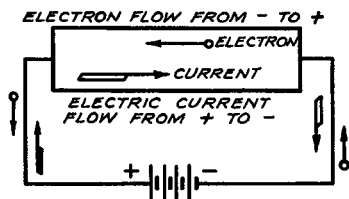

*Fig. 2. The flow of electrons is from the minus side of a battery to the plus, whereas current flow is considered to be from plus to minus, the latter being indicated by the tailed arrows.*

### Direct or Continuous Current

This volume is devoted to the distribution of what we classify as being d-c. voltages, which means that the current flowing in the circuit is naturally of the type classified as being direct current. In view of the fact that there is a distinction between d.c., or direct current, and a.c., or alternating current, we must make just one more reference to the connection between electron flow and electric current flow. When a d-c. voltage is applied to a circuit, the general direction of the electron drift is maintained the same. When the movement of the electrons is in one direction, the current in the circuit is said to be unidirectional, and is identified as being d.c. (direct current).

Pulsating current comes under the general classification of direct currents, because, while the magnitude of the current is not constant, its direction of flow is constant.

### Conductivity and Resistance

The distribution of d-c. voltage in the various circuits of a radio system involves the use of wire and other mediums which allow the flow of direct current. As such it becomes an important matter to have some idea concerning the factors which govern the conductive properties of these connecting mediums. . . . What do we mean by conductivity?

By conductivity of various mediums used in radio systems, we mean the quality or power of allowing the passage of electric

current. As a general rule, wires are good conductors of electricity, which means that the conductivity is high and the resistance is low. On the other hand, insulators are poor conductors, the conductivity being low and the resistance high. Referring once more to wires—there are essentially two general kinds. One general type of wire is known as electrical connecting wire. This is the regular, conventional copper wire, such as is used for the winding of coils, transformers, interconnection of circuits, etc. The other general variety is specified as “resistance” wire. The class of wires identified as connecting wires are good conductors of electrical currents and offer very little opposition to the flow of such currents. This means that their resistance per unit length is low. The resistance wires, on the other hand, offer more opposition to the flow of current. Expressed in another manner, their resistance per unit length is high.

It might be well at this time to state that all wires, irrespective of type, possess the property of resistance—that is, present opposition to the flow of current. Such opposition to the flow of direct current is expressed as d-c. resistance. Under certain conditions, the amount of resistance present is so low as to be negligible—whereas in other cases it is appreciable. The utility and the choice of wires with respect to their resistance is dependent upon the desired function and purpose of the wire.

At this time it would be quite natural if you asked why one type of wire should conduct electric current better than another type of wire. The reason is found in the atomic structure of the elements which comprise the wire. The ease with which an atom of a substance parts with an electron is considered to be indicative of the suitability of that material as a conductor of electricity. If a wire is composed of such materials that the atoms will part freely with electrons, then an abundant flow of electrons occurs through the circuit, and for any one unit length of such wire we will obtain a plentiful drift of electrons, which means that the current will be great through that wire and its resistance per unit length will be low. On the other hand, if the atomic structure of the wire is such that the atoms will not part freely with an electron, the flow of electrons through such a wire will not be abundant, which means that the current

through the circuit for the application of a unit value of voltage will be much less. The last named characteristic is possessed by those wires which are identified as being "resistance" wires. As a general rule, such wires are alloys of various combinations of metals, and the selection of those metals with respect to atomic structure is deliberately such that a high order of electronic affinity exists. High electronic affinity means that the atoms will not part freely with their electrons.



*Fig. 3, left, Fig. 4. The resistance of a wire is directly proportional to the length, see Fig. 3, and it is inversely proportional to the cross-sectional area, see Fig. 4.*

Another question which you no doubt think of in connection with this discussion, is the relation between the resistance of different lengths of wires and between thin and thick wires. If we assume a definite atomic structure for a certain wire, the resistance of that wire or conductor is proportional to the length and inversely proportional to the cross-section or the area. That is to say, if we have two lengths of the same wire or conductor, one of which, A, shown in Fig. 3, is 1 foot long, and B is 2 feet long, and if the resistance of A is 1 ohm, the resistance will be 2 ohms for B. Wires are usually specified as offering a certain amount of resistance per unit length and the resistance of longer or shorter lengths is then established by multiplying the resistance per unit length by the length of the conductor. It is quite natural that B would have twice as much resistance as A, since it is twice as long as A, and the path of electron travel is twice as long. If B were one hundred times as long as A, its resistance would then be one hundred times as great. On the other hand, if we have two wires, A and B, both of the same length and substance, but of different cross-section, so that the area of B is twice that of A, as shown in Fig. 4, the resistance of B will be half as much as that of A. The reason for this is that

the thicker the conductor or wire, the greater is the number of atoms present in that wire and the greater will be the electron flow, because more electrons are available within the unit length. In other words, if the resistance of A is 1 ohm per 1 foot length, the resistance of conductor B would be  $\frac{1}{2}$  ohm per 1 foot length. The thinner of two wires of similar material and length will have the higher resistance.

### Temperature Coefficient

Often when working upon radio systems, references to the d-c. resistance of circuits or devices *at certain temperatures are found*. Perhaps the temperature is not expressed in so many degrees, but rather the device is described as being "warm." The reason for this reference is that the resistance of conductors varies with temperature. This variation in d-c. resistance with temperature for metal conductors is in the positive direction; by "positive direction" we mean that it increases. The extent of the increase in resistance with temperature is not the same for all metals. As it happens, nickel wire shows the greatest increase in d-c. resistance with temperature. Next to nickel is pure iron wire. However, conductors used in radio systems are seldom made of either pure nickel or pure iron, so that this increase in resistance with temperature is not of great importance. . . . Certain types of resistance wires, such as manganin, Advance, Eureka possess very low positive temperature coefficients, which means that they increase very little in d-c. resistance value per degree increase of temperature. The copper wire used in many radio sets as the connecting wire, has a medium positive temperature coefficient, which becomes of importance when checking the d-c. resistance of a winding with many turns and one which carries appreciable current—as for example, a filter choke or transformer winding.

There are substances which possess a negative temperature coefficient, which means that the d-c. resistance *decreases* with an increase in temperature. Such substances are glass, carbon, quartz, graphite and porcelain. You may wonder why such materials are not used generally as conductors. There are a number of reasons why they are unsuited as conductors, the

most important being that the materials in themselves are not very good conductors and possess very high values of resistance. The only possible exceptions to this statement are carbon and graphite, which elements are used as resistors in radio systems.

### Unit of Resistance—Ohm

We have referred to resistance. The unit of resistance employed in connection with radio systems—for that matter, in connection with all electrical circuits, is the “ohm.” Georg Simon Ohm, a physicist, investigated the relation between resistance, current, and voltage in electrical circuits, and the unit of resistance bears his name. **Expressed from the practical viewpoint, the ohm is the amount of resistance possessed by a circuit when the application of one volt will cause the flow of one ampere of current.**

As a general rule, resistance is expressed in ohms or a fraction of an ohm, depending upon the value. It has become common practice, when expressing values of resistance, and when indicating a value of resistance of less than five thousand ohms, to quote the complete numerical value, as for example:

1 ohm  
450 ohms  
1,000 ohms  
3,000 ohms  
5,000 ohms  
9,500 ohms

For values in excess of this amount the figure is quoted as a decimal value of a megohm, or million ohms. (The prefix “meg” indicates a million.) For example:

10,000 ohms = .01 megohm  
50,000 ohms = .05 megohm  
75,000 ohms = .075 megohm  
100,000 ohms = .1 megohm  
235,000 ohms = .235 megohm

Resistance values in excess of a million ohms are invariably expressed in megohms, viz:

1,000,000 ohms = 1 megohm  
 2,000,000 ohms = 2 megohms  
 3,530,000 ohms = 3.53 megohms

As previously stated, the fraction of a megohm, represented by a resistance of less than five thousand ohms, is seldom used, but when used for certain common values, it would appear as the following:

2,500 ohms = .0025 megohm  
 1,000 ohms = .001 megohm  
 500 ohms = .0005 megohm

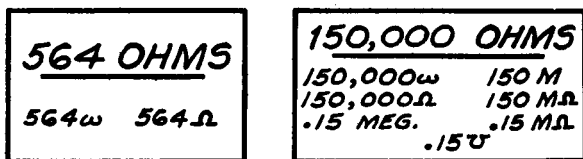

*Fig. 5, left, Fig. 6. The Greek letter "omega"—both small and capital—is used to indicate ohms, but that there is no standard usage is evident in Fig. 6, which shows the numerous ways the same value of resistance is written.*

It is unfortunate there is no standard method for representing the numerical values of resistors. In Figs. 5 and 6 we show the various symbols and methods which are in common use at the present time.

### Unit of Current—Ampere

The unit of current employed in radio systems is the ampere, and it is the amount of current which will flow through a circuit of one ohm resistance when the applied voltage is one volt. In view of the fact that the current in radio circuits is often much less than the unit ampere, use is made of the prefix "milli," to indicate one thousandth part, and the prefix "micro" to indicate one millionth part. Accordingly, a *milliamper*e is a thousandth part of an ampere, and a *microampere* is the equivalent of one millionth part of an ampere. There are, of course,

intermediate values of current between one ampere and a milliampere: as for example, one hundredth part of an ampere. In this connection it has become common practice to refer to currents of less than one ampere, but more than one milliamper, as being a certain number of milliamperes. For example, a current of one tenth of an ampere is the equivalent of one hundred milliamperes, and when referred to would be spoken of as one hundred milliamperes or one hundred mils. Then again, a current of eight-tenths of a milliamper, which is the equivalent of eight hundred microamperes, would be referred to as eight hundred microamperes, rather than eight-tenths of a milliamper. You are, of course, privileged to use whatever designation you see fit, but it is best to employ the designations commonly used in radio texts. Examples of the conversion of current from the unit value of one ampere to milliamperes or microamperes are given in the table at the end of this chapter.

### Unit of Potential-Volt

The unit of potential is the volt and is the amount of electric pressure required to cause the flow of one ampere of current through a resistance of one ohm. As in the case of current, reference is often made to decimal values of the unit volt, and the prefix "*milli*" to designate one thousandth part and the prefix "*micro*" to designate one millionth part are used. In certain cases, although not very often, reference is made to multiples of the unit volt and when the figure is in excess of one thousand volts, the prefix "*kilo*," to represent one thousand, is employed. As far as conversion of the unit volt into its decimal values is concerned, the manner in which this is handled is identical to that used with current. In other words, voltages of from one *microvolt*, or one millionth of a volt, up to one *millivolt*, or one thousandth part of a volt, are referred to as so many microvolts. Of course, when the value of voltage amounts to the unit value or greater than the unit value, then reference is made to so many unit volts or plain volts.



### Ohm's Law

Now we come to what is really the essence of this entire book, namely Ohm's Law. Thorough grounding in Ohm's Law is the open sesame to all problems relating to d-c. voltage distribution. Inasmuch as we are primarily concerned with direct-current circuits, our references to Ohm's Law will be made in connection with d-c. voltage and direct current. Irrespective of the type of work to be done, that is service work, design, or replacement, it is essential to understand the factors operating in Ohm's Law. The specific application is not the important item, inasmuch as this law, as it relates to direct current systems, is universally applicable.

If the resistance of a circuit is that factor which retards the flow of current when a voltage is applied, there must be some relation between the current, voltage and resistance in that circuit. . . . Actually there is such a relation and it is known as Ohm's Law. When expressed in the form of an equation this basic relation is

$$\text{Current} = \frac{\text{Voltage}}{\text{Resistance}}$$

When letters are used to designate these three quantities the equation appears as:

$$I = \frac{E}{R} \quad (1)$$

From this relation are derived two others:

$$E = I \times R \quad (2)$$

or voltage is equal to the current times the resistance, and

$$R = \frac{E}{I} \quad (3)$$

or resistance is equal to the voltage divided by the current.

These three equations indicate definite relations between the three quantities. Referring to (1), it can be seen that the current varies directly as the voltage, when the resistance in the circuit is kept constant, and that the current varies inversely as the resistance, when the voltage applied to the circuit is kept constant. Just what do we mean by these statements? Let us consider a simple electrical circuit such as that shown in Fig. 7.

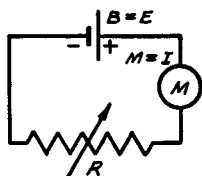

*Fig. 7. A basic electrical circuit energized by a battery  $B$  with the total resistance of the circuit indicated in  $R$ .  $M$  is an ammeter for showing the amount of current flowing in the circuit.*

$B$  is the source of voltage and we indicate it as equal to  $E$ .  $M$  is the meter used to indicate the current; hence the reference that  $M = I$ .  $R$  is the resistance. For the sake of simplicity we will assume that  $R$  represents the resistance of the entire system, rather than just the physical element indicated by  $R$ . Suppose that in this case  $E$  equals 10 volts and that  $R$ , for the moment, is equal to 5 ohms. Then according to equation number (1)

$$I = \frac{10 \text{ volts}}{5 \text{ ohms}}$$

$$I = 2 \text{ amperes}$$

Thus the value of the current is found to be 2 amperes. Now suppose that the resistance  $R$  is doubled, that is, increased in value to 10 ohms as against the previous value of 5 ohms. What will the current be now? Using the same relation, we have

$$I = \frac{10 \text{ volts}}{10 \text{ ohms}} = 1 \text{ ampere}$$

and the current is now equal to 1 ampere. If you analyze what has happened you will see that doubling the resistance in the circuit has halved the current. This is what is meant when it is

said that the current varies inversely as the resistance when the voltage is constant. Similarly if the resistance in the circuit were halved, then the current would double. If the resistance were tripled, then the current in the circuit would decrease to one-third of its former value. If the resistance were reduced to one-third, the current would increase to three times its original value.

On the other hand, we stated that the current is directly proportional to the voltage, when the resistance is maintained constant. This means that if the voltage is doubled, then the current will also be doubled. Similarly if the voltage is increased to 10 times its previous value, then the current will also be increased in the same proportion, that is, to 10 times its former value. If the voltage is halved, the current in the circuit is halved.

Equation (2) shows that the voltage developed or applied across a circuit is proportional to the resistance of the circuit or to the current in the circuit when either one is constant. In other words, let us again refer to Fig. 7. If the resistance  $R$  of this circuit is fixed at a certain value, let us say 10 ohms, and the current  $I$  indicated upon the meter,  $M$ , is 1 ampere, the voltage according to equation (2) is 10 volts. If the resistance is maintained at 10 ohms and it is desired to increase the current to 2 amperes, or twice its original value, the voltage required is 20 volts, according to equation (2). On the other hand, if the resistance is maintained at 10 ohms, and the current is reduced to half of its original value, or half (.5) ampere, the voltage is five (5) volts, according to equation (2). It is evident from these two examples of current variation that with the resistance fixed, the voltage change required is in proportion to the current variation. If the current is increased to 2 amperes, the voltage is increased two fold. On the other hand, if the current is decreased to one-half its value, the required voltage is decreased to one-half of its original value. Once again we must make the comment that actually the current in the circuit is dependent upon the applied voltage, whereas in our discussion we have referred first to current and then to voltage. This is done in order to show the relation between voltage and current when the current is known and voltage is the unknown quantity.

The relation between current and voltage with resistance fixed, in equation (2), is duplicated when the current is fixed and we are concerned with the relation between the voltage and the resistance. For example, if  $R$  in Fig. 7 is fixed at 10 ohms, and  $I$  is 1 ampere,  $E$  is 10 volts. Suppose that we vary  $R$  so that it becomes 20 ohms, and still desire that  $I$  be maintained at its original value of 1 ampere. The impressed voltage  $E$  must be 20 volts, in accordance with equation (2). If, on the other hand, the resistance of  $R$  in Fig. 7 is changed to 5 ohms, or half of its original value, and the desired current  $I$  is 1 ampere, the impressed voltage is 5 volts, in accordance with equation (2). Once again you see that the voltage variation is proportional to the resistance variation when the current is maintained constant. With the current constant and the resistance increased twofold, the voltage increases twofold. With the current constant and the resistance decreased to one-half of its original value, the voltage decreases to one-half of its original value.

Referring to equation (3) wherein the resistance  $R$  is the unknown quantity, we find that the resistance is proportional to the voltage with current constant, and inversely proportional to the current with the voltage constant. Having given two examples of inverse relations and direct proportional relations, we do not deem it necessary to go into a similar discussion. From what has been said in connection with equations (1) and (2), it should suffice to say that if the voltage is maintained constant in a circuit, such as given in Fig. 7, or for that matter any circuit, the resistance in that circuit varies oppositely to the current. If the current is maintained constant and the voltage is decreased in that circuit, the resistance will likewise decrease. Equation (3), of course, is useful primarily when the current and voltage are known and it is desired to find the resistance in the circuit.

We want to emphasize that in using Ohm's Law, it is highly important that the *current be expressed in amperes, the voltage in volts, and the resistance in ohms.* Since, as we have seen, these are not the most commonly used units in radio work, but that multiples or submultiples of these units are used, it is important that you know how to convert these to the basic units which must be substituted into the formula.

### Power Rating of Resistances

Whenever a current flows through a resistance, energy is dissipated in that resistance in the form of heat. Expressed in other terms, the electrical energy, which is supplied to the resistance in the form of current, is converted into thermal or heat energy.

The amount of heat developed in a unit is an important consideration in radio circuits. If too much heat is developed and the resistance unit cannot dissipate all of this heat, damage results. On the other hand, if the heat or energy dissipating capability of the resistor is adequate or more than adequate, then the heat, which is developed as a result of the passage of the current, is safely carried away.

*The unit of power which is used to measure the rate at which heat is developed in a resistance is the watt.* In terms of heat units, 1 watt is the equivalent of a certain amount of heat generated per second,—specifically 0.24 calorie per second. As we should expect, the amount of heat developed per second depends upon the current flowing through the resistance and the magnitude or size of the resistance. The fundamental relation which is used to calculate the number of watts being generated in a resistance, is given by the relationship

$$P = I^2R \quad (4)$$

where  $P$  is the power in watts;  $I$ , the current in amperes, and  $R$ , the resistance in ohms. But from Ohm's Law we know that any one of the quantities contained in the above equation can be expressed in terms of the other two and consequently there are two other expressions for the power. These are

$$P = I^2 \times R = I^2 \times \frac{E}{I} = IE \quad (5)$$

$$P = I^2R = \left(\frac{E}{R}\right)^2 \times R = \frac{E^2}{R} \quad (6)$$

Let us first consider the relation (4) where the power is expressed in terms of the current and the resistance. This equation states that in order to find the power developed in a resist-

ance,  $R$ , which is carrying a current,  $I$ , it is necessary to multiply the square of the current by the value of the resistance. Furthermore, *doubling the value of the current and keeping the resistance the same, will increase the power by a factor of four.* On the other hand, doubling the value of resistance and keeping the current constant will simply double the power  $P$ . For example, if a current of 2 amperes flows through a 10-ohm resistance, then the power is

$$P = I^2R = 2^2 \times 10 = 40 \text{ watts}$$

If the current is doubled,  $I = 4$  amperes, then

$$P = I^2R = 4^2 \times 10 = 160 \text{ watts}$$

and the power is now four times as great as before.

If the resistance is doubled,  $R = 20$  ohms, then

$$P = I^2R = 2^2 \times 20 = 80 \text{ watts}$$

and the power is only twice as large as before.

In the same way, the relations (5) and (6) can be used to compute the power, depending upon which quantities are known. When the current and resistance are known, equation (4) should be used to find the power dissipation. When the current through, and the voltage across a resistance are known, then the equation (5) is most convenient for the computation of the power. When the value of resistance and the voltage across the resistance are known, then equation (6) can be used to find the power.

The following practical example will illustrate how these relationships are used in practice. Suppose that it is necessary to replace a screen voltage-dropping resistor. The function of the resistor is to drop the voltage from 250 volts to 90 volts, and the value of resistance is known to be 200,000 ohms, the latter information being obtained from the schematic diagram or possibly from the color code on the resistor to be replaced. What must be the power rating of the replacement resistor? Since in this case we know the value of  $R$  and  $E$ , it is most convenient to use equation (6). We have, first of all, that the voltage across the resistor is 250 — 90, or 160 volts. Therefore, the power is

$$P = \frac{E^2}{R} = \frac{(160)^2}{200,000} = \frac{25,600}{200,000} = 0.13 \text{ watts}$$

The resistor then must be capable of dissipating or carrying away 0.13 watt of power. To allow an adequate factor of safety, the replacement resistor should be of the .5-watt capacity,—this being closest to the calculated power rating.

We might note at this point that the greater the ventilation and the more exposed a resistor is, so that the heat developed in it can be freely radiated and conducted away, the less chance there is that the power capability of the resistor will be exceeded. On the other hand, if the resistor is located in a confined area where there is little circulation of air, the temperature assumed by the resistor for a given amount of power will be appreciably higher and due allowance in the form of the use of a resistor of higher than the computed power rating must be made to prevent burn-out.

There is another relationship which is useful in connection with the power handling capacity of resistors. It often happens that the power rating of a resistor is known and it is desired to determine the maximum permissible current which the resistor can carry. This value of current which must not be exceeded is given by the square root of the power divided by the resistance:

$$I = \sqrt{\frac{P}{R}}$$

Suppose, for example, that you wish to find the maximum current which a 100-watt, 25-ohm rheostat can handle. Using the above equation

$$I = \sqrt{\frac{100}{25}} = \sqrt{4} = 2 \text{ amperes}$$

and the maximum value of current is thus 2 amperes.

In this connection it should be mentioned that the power rating of 100 watts refers to the entire value of resistance in the rheostat and is not applicable when a fraction of the total re-

sistance is used. For example, suppose that this same rheostat is adjusted so that only 4 ohms are being used. Let us calculate the maximum current on the assumption of the 100-watt power rating:

$$I = \sqrt{\frac{P}{R}} = \sqrt{\frac{100}{4}} = \sqrt{25} = 5 \text{ amperes}$$

With this assumption we arrive at a value of 5 amperes as a safe value of current. That this is false is at once apparent, since we computed above that the largest permissible current is 2 amperes. The error took place because of the erroneous assumption that a small part of the total resistance is capable of dissipating as much power as the entire value of resistance. *In general the safe procedure is to calculate the largest value of current when the entire resistance is used and to take this value of current as the value which must not be exceeded, regardless of how much of the total resistance is used.*

### Conversion Tables

The following relationships and examples will be useful in connection with specification of current, voltage and resistance in all cases.

To express milliamperes in terms of amperes	—divide	by 1,000
To express microamperes in terms of amperes	—divide	by 1,000,000
To express millivolts in terms of volts	—divide	by 1,000
To express microvolts in terms of volts	—divide	by 1,000,000
To express megohms in terms of ohms	—multiply	by 1,000,000

#### *Conversely*

To express amperes in terms of milliamperes	—multiply by 1,000
---	--------------------



To express amperes in terms of microamperes	—multiply by 1,000,000
To express volts in terms of millivolts	—multiply by 1,000
To express volts in terms of microvolts	—multiply by 1,000,000
To express ohms in terms of megohms	—divide by 1,000,000

The following examples should be studied to indicate how the above relationships are applied:

5 ma. or 5 milliamperes	equals .005 ampere
16 mv. or 16 millivolts	equals .016 volt
54 $\mu$ a or 54 microamperes	equals .000054 ampere
2.5 megohms	equals 2,500,000 ohms
1.2 amperes	equals 1,200 milliamperes or 1,200,000 microamperes
0.3 volt	equals 300 millivolts or 300,000 microvolts.

The analysis of d-c. voltage distribution in a radio receiver is a relatively simple matter. It means primarily identification of the type of circuit arrangement used which may also be expressed as the type of network used. In connection with such identification and analysis we are concerned primarily with the d-c. resistance of the component parts of the d-c. voltage distribution system and with the continuity of the circuit. As far as d-c. resistance is concerned—we do not care what the basic function of the device may be. . . . If it possess some value of d-c. resistance and allows the normal passage of direct current—it is of interest to us. From the viewpoint of d-c. resistance and voltage distribution, a transformer winding rated at a d-c. resistance of 1,000 ohms is no different from a fixed resistor of 1,000 ohms.

As far as d-c. circuit arrangements are concerned, there are three major basic varieties commonly found in radio systems of all types. These are identified as series, parallel and series-parallel. Once the type of circuit has been identified and various laws relating thereto are known, all further computations involve Ohm's Law—irrespective of the exact location of the

d-c. network—that is, its use in any part of a radio receiver, transmitter, amplifier or testing device. You will see as you progress through this text that the combination of a number of different parts of a radio receiver, transmitter, amplifier or testing device can be interpreted as being combinations of one or more of the three basic d-c. circuits—despite the assortment of names applied to the devices used in the system. . . . Since the series circuit is the simplest—it will start this discussion.

## Chapter II

### SERIES CIRCUITS

WHAT do we mean by a series circuit? . . . A series circuit is one in which there is but one path for the total current and in which the current is the same in all parts of the circuit. An example of the simplest series circuit is that shown in Fig. 8, wherein a conductor joins the two terminals of a battery, or

Fig. 8, left, Fig. 9. The simplest of all series circuits, Fig. 8, and a second in which a resistance,  $R$ , of 10 ohms is introduced. The battery,  $B$ , is rated at 10 volts.

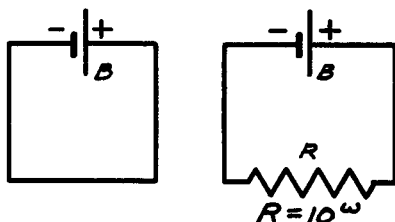

source of voltage. (Of course shorting a battery in this manner is not practical.) A more practical arrangement which we can use for analysis is that shown in Fig. 9, wherein the circuit consists of  $B$ , a source of voltage, and  $R$ , a resistor. The balance of the circuit consists of the conductor which connects the resistor across the battery. If we assume that the battery  $B$  supplies a voltage of 10 volts, and the resistor  $R$  is of 10 ohms, the current through that circuit, in accordance with Ohm's Law for current is,

$$I = \frac{E}{R} = \frac{10}{10} = 1 \text{ ampere}$$

As you note, the resistance of the conductor and the internal resistance of the battery are considered to be included in  $R$ .

If you examine Fig. 9, you will note that the one ampere of current, already established as flowing in the circuit, flows in all parts of the circuit and if a meter is placed in any point in the circuit, it will indicate that value of current.

We speak of  $R$  as being a resistance. The statement, however, does not mean that the resistance of 10 ohms must be that of a resistor unit. The resistance in the circuit can be that of a winding, as, for example, the winding of an r-f. transformer—or a choke—or, for that matter, any device which will offer opposition to the flow of current, yet not interrupt continuity. In other words, the circuit of Fig. 10, wherein the winding has

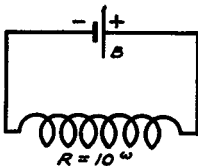

*Fig. 10. Here a coil, whose resistance is 10 ohms, is shown in place of the resistor shown in Fig. 9. This substitution makes no difference in the application of Ohm's Law, provided that the device does not interfere with the passage of the current, other than offering the normal ohmic resistance.*

a resistance of 10 ohms, from the steady current viewpoint is identical with that of Fig. 9. As far as the distribution of d-c. voltage and direction of current flow are concerned, the nature of the device which offers the required opposition to the flow of current is of no importance—providing that the nature of the device does not conflict with the circuit. The items of primary interest are, first, that the path be continuous so as to allow the flow of current from the positive side of the voltage supply source to the negative side of that source. Second, that the amount of d-c. resistance supposed to be in the circuit—is actually in the circuit.

It might be well, at this time, to dwell upon the first half of the preceding sentence. In view of the various complicated networks to be found in radio systems, it is necessary to stress that when analyzing the distribution of d-c. voltages and direct current flow in radio systems, attention be paid to satisfactory continuity in the system. In other words, it is imperative that you recognize the presence of those devices which are essential parts of the radio system, yet are not a part of the d-c. distribution system. We are referring particularly to the presence of a condenser, fixed or variable, whichever it may be. While it is true

that all condensers possess a certain amount of d-c. resistance, normally identified as insulation resistance or leakage resistance, such devices, when in perfect operating state, possess such high values of resistance that they are, in effect, insulators against the flow of direct current and prevent the distribution of d-c. voltages through the circuit which contains the condenser. When making this statement we recognize that electrolytic condensers afford more ready paths for the flow of direct current than solid or air dielectric condensers. Notwithstanding this condition, the statement still holds true, because such condensers are never located in circuits which distribute direct currents.

Recognizing that a condenser is an insulator against the flow of direct current, a series circuit, such as that shown in Fig. 11, wherein the condenser C is in series with resistor R, will not allow the steady flow of current as a result of the voltage applied

*Fig. 11, left, Fig. 12. Direct current will not flow through R, Fig. 11, unless the condenser is defective, but it will flow in the circuit of Fig. 12, as indicated by the arrows.*

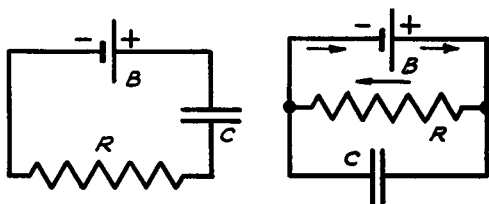

by battery B. If, by chance, this condenser is not perfect electrically, which condition may be productive of a very low insulation resistance, or if the condenser is internally shorted, it will act as a conductor and current will flow in the system. On the other hand, if the arrangement of this simple circuit is such that the condenser C is in parallel with the device represented by R, as shown in Fig. 12, continuity of the circuit is not interrupted and current will flow through the device represented by R. No current flows through the capacitive circuit, because, as originally stated, this condenser acts as an insulator, when in good electrical condition. For future reference it is imperative to remember the statements made concerning such condensers, because the design of many radio systems is such that a condenser appears associated with the d-c. voltage distribution system, but in reality functions as a means of insulating one part of the system from some other. Instead of providing a path for the

direct current flow and the application of a d-c. voltage to some point, it actually blocks or prevents the passage of direct current and insulates some point from the d-c. voltage.

### Resistances in Series

From what has been said concerning series circuits, and in accordance with the illustration given, it is possible that you will develop the erroneous idea that a series circuit can contain but one resistor and/or that a series circuit cannot contain any devices other than pure resistances. . . . Both of these ideas should be dispelled, because they are very far from the truth.

To start with, a series circuit can contain any number of elements or units connected in series, providing, as has been mentioned, suitable continuity is available through these units.

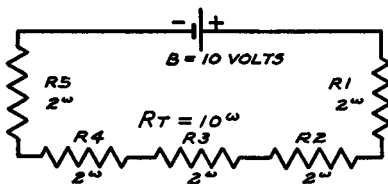

*Fig. 13. The total resistance of the five 2-ohm resistors equals the resistance of that in Fig. 9, which is an example of the rule for series resistances given below.*

For example, the circuit of Fig. 9 can be shown as Fig. 13, consisting of five resistor units, R1, R2, R3, R4 and R5 in series. The basis for saying that these resistors are connected in series is that the connection of the units provides but one path for the current and that the total circuit current flows through each of the resistors or is the same throughout the circuit.

There is a basic electrical law which states that

**“The total resistance of a number of resistances in series is the sum of the individual resistances.”**

According to this law, the total resistance  $R_t = R_1 + R_2 + R_3 + R_4 + R_5$

According to this law, the circuit of Fig. 13 is identical to that of Fig. 9, except for the fact that five resistors are shown in Fig. 13, whereas only one resistor is shown in Fig. 9.

There will be times when it is advantageous to identify each of the resistors in a series network containing more than one unit, and there are times when it is possible to resolve any number of series resistances into a single resistance. An example of this case is the determination of the current flowing in the circuit. If the circuit contains but a single resistance, then that unit presents the total opposition to the flow of current. Thus the current in Fig. 9 is determined by the equation

$$I = \frac{E}{R}$$

When several resistors are connected in series, each unit contributes a certain amount of opposition to the current flow and the total opposition is the sum of each individual amount of opposition so that the equation for the current flow in Fig. 13, is

$$I = \frac{E}{R_1 + R_2 + R_3 + R_4 + R_5}$$

However

$$R_t = R_1 + R_2 + R_3 + R_4 + R_5$$

so that

$$I = \frac{E}{R_t}$$

which is identical to the equation applicable to Fig. 9, except for the fact that the sum of five resistance values in Fig. 13 is used instead of the single resistance value, in Fig. 9.

At this time it might be well to mention that the law previously quoted concerning the addition of resistances in series is applicable to any combination of values. It is not essential that all values be alike as used in the illustration. It is perfectly possible for one value to be two, three, ten or even fifty times as great as the other. . . . It might be well to mention that the same law applies to any number of units in the combination.

. . . A series circuit may consist of any number of units in series.

Now for a few comments concerning types of units. If you recall, we stated that as far as voltage distribution or current flow is concerned, a winding of 10 ohms or 1,000 ohms d-c. resistance present in a d-c. circuit has exactly the same effect upon current flow as a resistor of 10 ohms or 1,000 ohms respectively. (See Figs. 9 and 10.) The same is true when more than one unit is connected in series. For example, a circuit such as that shown in Fig. 14, consisting of a filter choke FC, a tube

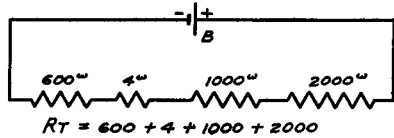
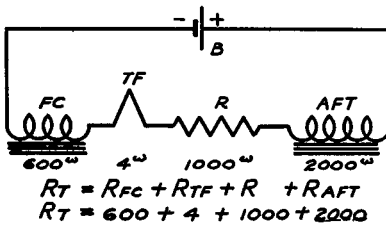

Fig. 14, left, Fig. 15. The units shown in Fig. 14 offer various amounts of resistance as indicated and can be considered as pure resistances, as shown in Fig. 15.

filament TF, a fixed resistance R, and an audio transformer primary AFT with ohmic values as shown, is no different as far as total circuit resistance or direct current flow is concerned from the four series resistance combination shown in Fig. 15.

### Voltage Drop

When a voltage is applied across a circuit, current flows through the circuit. . . . This current is due to the difference of potential which exists across the terminals of the source of voltage and we can also see that this source of voltage supplies an electric pressure or electromotive force, (the force to move the electron). . . . By the same token, whenever current flows through a circuit—or any portion of a circuit—a voltage must exist across the circuit or across a portion of the circuit.

Let us delve a little deeper. . . . Consider the circuit shown in Fig. 16. A source of d-c. voltage, type not important, supplying 100 volts, is connected across the series combination of three resistors, R<sub>1</sub>, R<sub>2</sub> and R<sub>3</sub>. Since the total resistance of the series



resistances is the sum of the individual resistances, the total resistance of this circuit is  $9,000 + 900 + 100$ , or  $10,000$  ohms. In accordance with Ohm's Law for current, the current in this series circuit is

$$I = \frac{E}{R} = \frac{100}{10,000} = .01 \text{ ampere}$$

This current of .01 ampere flows through the circuit, hence through each resistor in that series circuit.

Now we have to use a little imagination. . . . What is really happening with the applied voltage  $E$ ? We know that it is fixed in value. We also know that it is forcing current through the three series resistances. . . . It is overcoming the opposition offered individually and collectively by these resistances. However, we also know that a voltage must exist across each and every part of a circuit in order that current will flow through these parts. . . . That is a basic law. . . . This means that a voltage or difference of potential must exist across each of the three resistors,  $R_1$ ,  $R_2$  and  $R_3$ . . . . **And the amount of voltage or difference of potential which must exist across these resistors, is the amount needed in accordance with Ohm's Law to overcome the opposition presented by each resistance to the flow of current through the resistance.**

If we expressed this in another manner—the amount of voltage which must exist across each resistance is the amount which

*Fig. 16. The current of 0.01 ampere flowing in the three resistors results in the voltage drops as indicated at the terminals A, B, C, and D.*

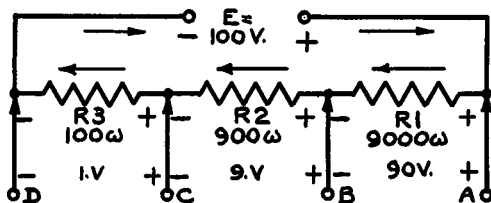

would be needed to force the calculated value of current, (.01 ampere), through each of these resistors, if each were in a separate circuit by itself. . . .

Where does this voltage come from? . . . Stated in the simplest manner—we can say that in a series circuit the applied voltage is divided among the various elements of the series cir-

cuit. . . . How is this voltage divided? The division of the voltage is dependent upon the Ohm's Law relation for the voltage required to force a certain value of current through a definite value of resistance. In other words—the portion of the total applied e.m.f.,  $E$ , “expended” or “used up” or “dropped” across  $R_1$  is the amount needed to overcome the 9,000-ohm opposition to the extent that .01 ampere will flow through  $R_1$ . The portion of the total e.m.f.,  $E$ , “expended,” “used up” or “dropped” across  $R_2$  is the amount needed to overcome the 900-ohm opposition to the extent that .01 ampere will flow through  $R_2$ . . . . The portion of the total e.m.f.,  $E$ , “expended,” “used up” or “dropped” across  $R_3$  is the amount needed to overcome the 100-ohm opposition to the extent that .01 ampere will flow through that resistor. Expressed in the form of Ohm's Law equations, the division of the applied e.m.f.,  $E$ , across the various elements of this series circuit is

$$E_{R_1} = I \times R_1 = .01 \times 9,000 = 90 \text{ volts (A to B)}$$

$$E_{R_2} = I \times R_2 = .01 \times 900 = 9 \text{ volts (B to C)}$$

$$E_{R_3} = I \times R_3 = .01 \times 100 = 1 \text{ volt (C to D)}$$

and

$$E_{\text{applied}} = E_{R_1} + E_{R_2} + E_{R_3}$$

$$E_{\text{applied}} = 90 + 9 + 1$$

$$E_{\text{applied}} = 100 \text{ volts}$$

The division of the applied e.m.f. “ $E$ ” across the various elements of a series circuit is dependent upon the current through the element and the resistance of the element or  $I \times R$ , as has been shown, and is usually known as *the IR drop or voltage drop*. . . . A definite relation exists between the applied e.m.f. and the respective IR drops in a series circuit and this relation is expressed in the law which states that—

**“The sum of the individual IR drops in a series circuit is equal to the applied voltage or e.m.f.”**

This is shown in the last stated set of equations and holds true irrespective of the number of resistances in the circuit or the nature of the devices employed and which may be represented

as resistances. That such a law is quite natural becomes apparent when you analyze the fact that the sum of the resistances in series is the total resistance of the circuit;—that the total current is determined by the total resistance when the applied e.m.f. is fixed, and that the voltage across each resistor is the product of the current times the ohmic value of that resistor.

If you refer to the circuit in Fig. 16, and also to the equation for the voltage drop across these various resistors, you will note that 90 volts is the drop across R1 or between the terminals A and B;—that 9 volts is the IR drop across R2 or between terminals B and C, and that 1 volt is the IR drop across R3 or between terminals C and D. Terminals B and C are common to two resistors each because they are located at the junction points—B between resistors R1 and R2 and C between resistors R2 and R3.

At this time you may wonder about the utility of the IR drop. . . . Does it serve any purpose? The answer is yes—several purposes, some of which will be outlined in this general review, and some of which will appear in the chapter devoted to practical applications. To start with, consider the voltages available between the A, B and C terminals with respect to the initially applied voltage E. The applied voltage or e.m.f. is 100 volts—a single fixed value. . . . However, across the terminals A, B, C and D, in various combinations, we have available six separate and distinct voltages, namely:

- 100 volts between A and D
- 90 volts between A and B
- 99 volts between A and C
- 10 volts between B and D
- 9 volts between B and C
- 1 volt between C and D

In other words, such a series network enables a division of the applied voltage. As a matter of fact, this series network is the equivalent of a *voltage divider* system—and such it is. Speaking about voltage dividers—they are not limited to the use of three resistances. Any number may be used and, furthermore, it is not essential that the units in the network be resistors. Any other type of unit, such as a coil winding, possessed of the re-

quired value of d-c. resistance can be used in place of a resistor. . . .

It might be well at this time to mention that there is another consideration related to the operation of a series type voltage divider—that introduced by the term “I” (the current) flowing through the respective resistances. The drop across the sections is at certain values of current, hence the voltage available at the various taps, other than the two extreme terminals, is with limited current. . . . This will be discussed later.

Referring once more to IR drop across the various resistors in a series combination, it is possible to employ this drop in various ways. For example, an IR drop is established so as to reduce the available voltage to a required amount. For example, we desire to reduce 100 volts to 25 volts and the device which requires this voltage also requires a current of .5 ampere. This means that we must produce a voltage drop equal to the difference between the available voltage and the required voltage, or  $100 - 25 = 75$  volts at .5 ampere. According to Ohm’s Law for resistance, the value of this voltage-dropping resistor is

$$R_x = \frac{E}{I} = \frac{75}{.5} = 150 \text{ ohms}$$

The circuit which would be used is shown in Fig. 17 where R is the representation of the device which requires 25 volts at .5 ampere and  $R_x$  is the voltage-dropping resistance across which we drop, expend, or dissipate 75 volts. The d-c. resistance of the device which requires 25 volts at .5 ampere is according to Ohm’s Law

$$R = \frac{E}{I} = \frac{25}{.5} = 50 \text{ ohms}$$

hence

$$E_R = I \times R = .5 \times 50 = 25 \text{ volts}$$

and

$$E_{R_x} = I \times R_x = .5 \times 150 = 75 \text{ volts}$$

There is another point of interest relating to the division of the applied e.m.f. as the voltage drop among the resistors of the

series combination. *This is that the ratio between the respective voltage drops is proportional to the ratio of the respective resistances and vice versa.* For example, in Fig. 17 we find two resistances,  $R$  being the resistance of the device which requires a certain voltage, namely, 25 volts, and  $R_x$ , the voltage-dropping resistor. The entire available voltage will be divided between these two resistors. . . . In what proportion? Let us say that

**Fig. 17, right.** *If the voltage drops across series resistors are known, their resistances can be found, as the ratio between their IR drops is proportional to the ratio of their respective resistances.*

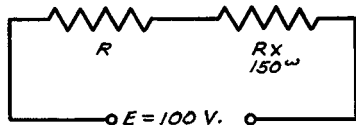

*R IS THE DEVICE WHICH REQUIRES 25 VOLTS AT .5 AMPERE AND IS EQUAL TO  $\frac{25}{.5} = 50$  OHMS*

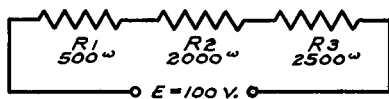

**Fig. 18, left.** *If the values of resistances are known, the respective voltage drops across them can be determined by establishing the ratios between the known values.*

the available voltage represents 100%. The required voltage being 25 volts, it is one-quarter or 25% of the total available voltage. . . . Then three-quarters of the total available voltage or 75% of the total available voltage—which is 75 volts—must be dissipated. . . . The voltage to be dissipated is, therefore, three times as great as the voltage required. . . . If a drop of 25 volts at .5 ampere is needed, the resistance of that device is, as has been shown, 50 ohms. This resistance will cause a drop of 25 volts and since another drop three times as great is needed, the resistance to produce this drop must be three times as great or  $50 \times 3 = 150$  ohms.

Reversing the picture and knowing the values of the resistances in the circuit, the respective drops may be computed by establishing the ratio between the resistances. For example in Fig. 18 three resistors,  $R_1 = 500$  ohms,  $R_2 = 2,000$  ohms and  $R_3 = 2,500$  ohms, are shown. The total resistance then is 5,000 ohms and the drop across the entire 5,000 ohms is going to be 100 volts. . . . How will the drop be divided between  $R_1$ ,  $R_2$

and R3? . . . The resistance R1 is equal to 10% of the total 5,000 ohms, so that 10% of the total voltage will be dropped across R1. This is 10 volts or

$$\frac{500}{5,000} \times 100 = 10 \text{ volts}$$

In turn, the resistance R2 is equal to 40% of the total resistance, so that the drop across R2 will be 40% of the total voltage. This is 40 volts or

$$\frac{2,000}{5,000} \times 100 = 40 \text{ volts}$$

In turn, the resistance of R3 is equal to 50% of the total resistance, so that the drop across R3 will be equal to 50% of the total voltage. This is 50 volts or

$$\frac{2,500}{5,000} \times 100 = 50 \text{ volts}$$

If you take the sum of the individual percentages, you will find that they amount to 100%, and if you take the sum of the individual drops, you will find that they equal the applied voltage.

### **Polarity of Voltage Drop**

What is the polarity of the voltage drops developed across the various elements in a series circuit? . . . Bearing in mind that the voltage drop is the consequence of current flow through the resistor, it is not surprising to learn that the polarity of the voltage developed as a consequence of this current flow is in accordance with the direction of the current flow. . . . While it is true that we have made specific reference to series circuits, it might be well if you realize that this statement is applicable to any and all types of circuits. The arrangement of the resistances with respect to the source of voltage and the current flow in the circuit does not alter the fact that the polarity of the voltage drop is the same as the direction of the current flow. The rule applies

to series circuits, parallel circuits, which, as it happens, have not been discussed as yet but will be shortly, and to series parallel circuits,—also to be discussed later.

Continuing with series circuits, suppose that you consider the schematic and the information shown in Fig. 19. This arrangement is an elaboration of the circuit shown in Fig. 16. The arrows within the series circuit indicate the direction of the cur-

**Fig. 19.** The points B and C have two different polarities indicated and this shows how the polarity at any point in a d-c. circuit depends on the relation between that point and some other point in the circuit. The IR drops across the resistors are indicated on the right with their respective polarities.

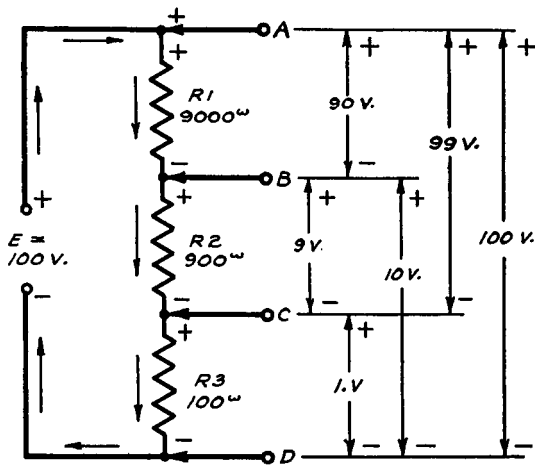

rent flow and, as is evident, these arrows show that the current flows from the most positive side of the circuit to the most negative side of the circuit,—from the plus terminal of the source of applied voltage to the minus terminal of the source of the applied voltage. Electric current flows away from the “high” or plus side of the circuit. . . . According to this method of reasoning, current then is flowing away from the top of R1, which is identified as point A, and is flowing towards the bottom of R1, which is identified as point B. . . . This makes the top of R1 the “high” end or the (+) end, and the bottom of R1 the “low” end or the (−) end. Therefore, terminal A is (+) and terminal B is (−). If we now speak about the voltage drop developed across R1, the polarity of this voltage drop is such that point A is the high terminal, or plus terminal, and B is the low or minus terminal.

Continuing on we find that the current is flowing away from the top of R2 and is flowing towards the bottom of R2, which means that as far as resistor R2 is concerned, the polarity of the voltage drop is such that it makes the top of R2, which is shown as being connected to point B, plus—and the bottom of R2, shown as being joined to point C, minus. As a result of the current flow in the system, a 9-volt drop exists between terminals B and C, and the polarity of this voltage is as indicated.

Continuing on, the current is flowing away from the top of R3 towards the bottom of R3, and since point C is connected to the top of R3 and point D is connected to the bottom of R3, the polarity of the voltage developed across R3 is such that point C is positive, or plus, and point D is negative, or minus.

More than likely you have noted that points B and C seem to have dual polarity. . . . This is quite correct and, for that matter, *all points in a d-c. circuit possess dual polarity. The exact polarity at any point is dependent upon the relative relation between that point and some other point in the circuit.* This is a very important matter and should at all times be remembered.

We have identified point A as being positive with respect to point B, yet if we consider that current is flowing away from the plus side of the voltage supply source towards point A—then point A must be negative with respect to the plus terminal of the source of applied voltage. For that matter, every part of the circuit is negative with respect to the (+) terminal of the source of applied voltage—if the latter is considered as the reference point. On the other hand, we have identified terminal D as being negative with respect to terminal C, yet if we recognize that current is flowing away from terminal D towards the negative terminal of the voltage supply source, then in truth terminal D is positive with respect to the (—) terminal of the source of applied voltage. Once more, if the negative terminal of the source of applied voltage is considered to be the reference point—then all other points in the circuit are positive with respect to that same reference point.

Referring again to points A, B, C, and D, the polarities are relative with respect to each other. The reason why points B and C appear to have dual polarity is that they are common junction points for the three resistors and when B is viewed



with respect to R1, it is the point towards which the current is flowing and, therefore, is negative. However, if point B is viewed with respect to R2, then it is the point from which the current is flowing away towards some other point and consequently point B becomes positive. The same considerations apply to point C, except that in this case we are concerned with resistors R2 and R3. . . . The change in polarity of point C is due to the fact that in one case the current is flowing towards point C, whereas in the other case it is flowing away from point C.

It is customary in practice when considering voltage drop, without being concerned about polarity, to establish the point of highest potential as being the reference point. This is point A in the resistor network shown in Fig. 19. As we move down from point A, or from the point of highest potential towards the point of lowest potential, there results what is known as a *fall of potential*. This is quite natural, inasmuch as voltage is being expended in the effort to force the current through the circuit and the further away we move from the highest point, the greater is the drop between the point of highest potential and wherever we may be located. For example, in Fig. 19 the plus terminal of the source of applied voltage is actually the point of highest potential. Since current is forced to flow through the circuit to point A, it is natural that a certain amount of drop will take place along the conductor which links the plus terminal of the source of voltage and point A. Hence point A is at a lower potential than the plus terminal of the source of voltage. No matter how low the resistance of the circuit, a fall of potential takes place all along the circuit as we move from the (+) terminal of the source of voltage to the (—) terminal.

We stated that if point A is selected as the most positive point in the system, then all of the points in that system working towards the minus terminal of the voltage supply source are negative. This means that point B can be classified as being negative with respect to point A. . . . Point C, likewise, can be classified as being negative with respect to point A and point D can also be classified as being negative with respect to point A. Such an arrangement is actually found in practice. In other words, if we distribute the voltage developed across this voltage divider system to three different points which require three

different potentials, namely, 90 volts, 99 volts and 100 volts, all of which are minus with respect to the reference point, the circuit

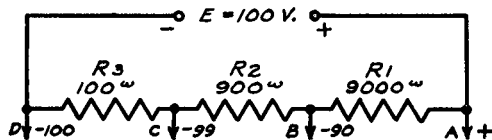

*Fig. 20. The voltage divider of Fig. 19 is shown. The three voltages are taken with respect to A as the reference point.*

is as shown in Fig. 20. This is the basis, as you will learn later, for the distribution of bias voltages in connection with the various types of rectifiers.

### Variation in Polarity with Ground

In days gone by it was common practice to consider the most negative point in the system as being at ground potential. By being at ground potential is normally meant being connected to ground. . . . Expressed in another manner, we can say that it was common practice to consider the ground terminal in a radio system to be the most negative point, and that all other points in the system were at a higher potential. . . . In other words, all other points in the system were positive with respect to ground. Such is not the case today. . . . As a matter of fact, a large number of radio systems employ arrangements wherein the ground is negative with respect to certain points in the system,—and positive with respect to other points. Recognition of the manner in which such a condition may exist is a most important consideration; particularly in connection with automatic volume control systems in radio receivers and in connection with various types of biasing systems.

An example of the manner in which a grounded point in a voltage distribution system has dual polarity is shown in Fig. 21.

### Internal Resistance and Internal Voltage Drop

It might be well at this time, before advancing to practical applications of series circuits, to mention briefly that voltage supply sources are possessed of what is known as internal resistance.

If we consider the internal resistance of the voltage supply source, it is necessary to augment the expression for current in a d-c. circuit to read as follows:

$$I = \frac{E}{R + r}$$

where the capital letter R designates the external resistance of the circuit, and the small letter r is the internal resistance of the voltage supply source.

*Fig. 21. The point B, which is grounded, has a dual polarity. It is minus with respect to the point A, but is positive with respect to the points C and D. Such conditions are often found in modern receivers.*

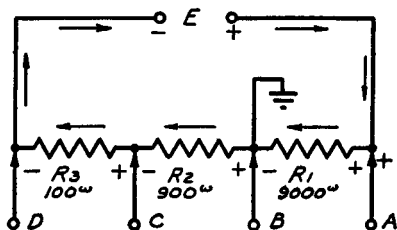

If we consider the internal drop in a series circuit, it is necessary to augment the expression for the total voltage drop in a circuit to read as follows:

$$E = IR + Ir$$

wherein IR is the external voltage drop and Ir is the internal voltage drop.

## Chapter III

### PRACTICAL APPLICATIONS OF SERIES CIRCUITS

Let us now consider some radio circuits encountered in practice and which are representative of, or are based upon the basic series circuit. Inasmuch as we are interested in d-c. voltage distribution systems, the examples selected are those which involve distribution of d-c. voltage and the flow of direct current in various arrangements employed in radio systems and allied equipment.

Without a doubt, the most frequently employed important device to be found in a radio system is the vacuum tube. Consequently, it might be best to start this discussion with various series circuits built around the vacuum tube.

#### Plate Circuits

If you recall, we made the statement in the early part of this book, that electron flow is from the minus to the plus side of the circuit. Such is actually the case in the vacuum tube. The electrons are emitted by the cathode or filament, whichever type of tube is used, and because of the application of a positive charge upon the plate of the tube, the electrons are attracted to the plate. The electron flow in the plate-cathode circuit of the vacuum tube is illustrated in Fig. 22 by the direction of the arrows. *Electric current flow, on the other hand, is, as has already been stated, in a direction opposite to that of the electron flow.* A pictorial representation of the direction of this current flow appears in Fig. 23, and, as indicated by the direction of the arrows, is from the positive to the negative side of the circuit.

Now, while it is true that the plate and the cathode are not mechanically joined internally, current does flow between these

two elements within the tube, and the magnitude of this current is limited by the resistance existing between these elements. When we speak of the d-c. plate circuit resistance of a vacuum tube, we mean the resistance to the flow of electrons between the plate and the source of electrons, which naturally means the flow of current between these elements. The magnitude of this d-c. resistance is a function of the design of the tube. It is also a function of the operating potentials which are applied to the tube, namely, the plate voltage divided by the plate current. The

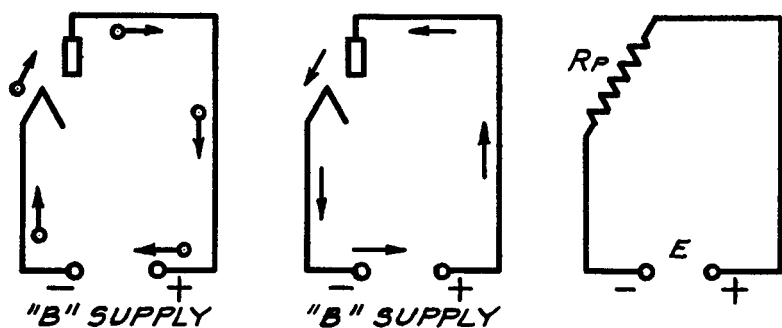

*Figs. 22, 23, 24, left to right. The direction of the electron and current flow in the plate circuit of a vacuum tube are indicated by the arrows in Figs. 22 and 23 respectively. The plate resistance of a tube is shown as a resistor,  $R_p$ , in Fig. 24.*

last reference is again a matter of tube design, because the tube is intended to possess a certain value of plate resistance, when certain values of operating potentials are applied. In other words, for a fixed value of "B" voltage applied to the plate, and for a fixed electron emitting temperature of the cathode or filament,—and for a fixed value of control grid bias (not shown in the illustration)—we assume the existence of a certain value of resistance between the plate and the cathode within the tube. As a general rule the exact value of this plate resistance for certain specified values of operating potentials is usually quoted in tube tables. Generally it is possible, for the purpose of analysis, to replace the plate resistance with a pure resistance. This is shown in Fig. 24, wherein the circuit consists of a source of

voltage  $E$  and a resistor  $R_P$ , representing the B voltage supply and the internal plate resistance respectively. If you compare this circuit with the series circuit shown in Fig. 9, you will find that the vacuum tube circuit being discussed is the equivalent of the simple basic series circuit.

It is extremely important that you recognize the nature of the plate-cathode circuit of a vacuum tube. If you will make an effort to remember, for further references, that this circuit is basically a simple series circuit, you will find it very much easier to comprehend other relations, as they make their appearance in this discussion. The reason why we show the resistance  $R_P$  at an angle, is to identify its connection more closely with the plate and cathode elements shown in the preceding two figures.

The representation of the internal plate resistance of a vacuum tube by means of a resistor  $R_P$ , as shown in Fig. 24, is not for this one illustration only. Each and every vacuum tube possesses some value of plate resistance. In other words, diode rectifiers, regular power rectifiers, r-f. pentodes, power output tubes, etc.,—all vacuum tubes irrespective of the number of elements, possess some value of internal plate resistance. In each and every case it is possible to illustrate this internal plate resistance with a fixed resistor, and in each and every case, as the consequence of the design of the vacuum tube and the operating potentials, the internal plate resistance is the primary current-limiting factor. Since this internal plate resistance is inherent in the tube, it is always present, irrespective of what other units may be inserted into the circuit. By this we mean that if we add an element with resistance into the plate circuit of the tube, outside the tube—the internal plate resistance is still existent. Consequently, irrespective of the elements contained externally in the plate-cathode circuit of the tube, and irrespective of the amount of current flowing in the system, a d-c. voltage drop will develop across the internal plate resistance of the tube, just so long as there is direct current flow in the circuit.

Let us assume that we do not know the value of  $R_P$ , the plate resistance of the tube, and that we apply a voltage of 180 volts. We establish, by means of a meter, that the current flow in the circuit is .0045 ampere or 4500 microamperes or 4.5 milli-amperes. In order to be able to establish the plate resistance by

means of Ohm's Law, we must use the value of current expressed in terms of amperes. This means that the resistance of the circuit, which in this case is the d-c. plate resistance, is

$$R = \frac{E}{I} = \frac{180}{.0045} = 40,000 \text{ ohms}$$

where E is the voltage at the plate and I is the plate current.

Since there is only one resistor in the circuit, it stands to reason that the entire voltage drop takes place across the resistor  $R_P$ , or across the plate resistance of the tube.

*Fig. 25, left, Fig. 26. The plate voltage is fed to the plate of the tube through the resistor,  $R_L$  the direction of the current being indicated by the arrow in Fig. 25. The electrical equivalents are shown in Fig. 26 with the IR drops of each.*

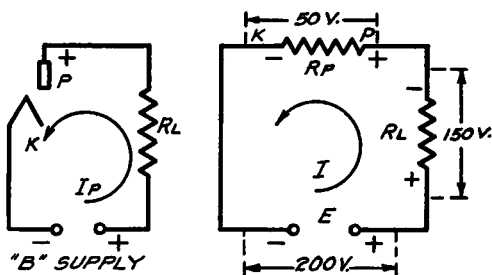

We know from practice that various elements may be incorporated in the plate circuit of a vacuum tube, and that the plate voltage is applied to the plate of the tube through these elements. A circuit representation of such an element is shown in Fig. 25, wherein a resistance  $R_L$  is located in the plate circuit of the vacuum tube. The electrical equivalent of the complete circuit of Fig. 25 is shown in Fig. 26, wherein  $R_P$  is the internal plate resistance,  $R_L$  is the external resistance and E is the B voltage supply. . . .  $R_L$  need not be a pure resistor. . . . It can be the d-c. resistance of a choke, transformer winding, etc.

If you will again refer to Fig. 25, you will find that the polarity of the plate is identified as being positive. This is quite natural in that the positive side of the B voltage is connected to the plate through the device located in the plate circuit. However, the plate of a vacuum tube is positive only with respect to the negative side of the B voltage supply source. For that matter, as originally stated in connection with series circuits, if the negative end of the voltage supply source is taken as the reference point,—

then the other points in the system are positive. If you will refer to Fig. 26, you will find similar polarity identification. However, you will also note two negative signs. These negative signs identify the polarity of the respective ends of the tube resistance and the external resistance with respect to the positive terminal of the B voltage supply, or the positive terminal of the applied voltage E. In other words, *the plate of the vacuum tube has dual polarity, being positive with respect to the negative end of the B voltage supply source and negative with respect to the positive end of the voltage supply source.*

The addition of the external resistance  $R_L$ , which is normally spoken of as the load resistance or the load applied to the vacuum tube, adds another resistance to the series circuit, and since we know that in a series circuit the applied voltage is distributed between the various resistances in the form of voltage drop, the applied voltage E is divided across  $R_P$  and  $R_L$ . The voltage across  $R_L$  is

$$E_{RL} = I \times R_L$$

and the voltage across the internal plate resistance is

$$E_{RP} = I \times R_P$$

For example, if the B voltage is 200 volts, the internal plate resistance is 50,000 ohms, and the external resistance in the plate circuit of the tube is 150,000 ohms, the total resistance or  $R_P$  plus  $R_L$  equals 200,000 ohms. The current flowing in the circuit then is equal to

$$I = \frac{E}{R_P + R_L} = \frac{200}{50,000 + 150,000} = .001 \text{ ampere}$$

According to Ohm's Law, the voltage drop across  $R_L$  is

$$E_{RL} = .001 \times 150,000 = 150 \text{ volts.}$$

Since the total voltage is 200 volts, neglecting the possible drop in the voltage supply source, the voltage across the internal plate resistance of the tube is 50 volts. This can be checked by multiplying the current through the tube times the internal plate resistance.



Referring to Fig. 26, let us consider another case using different values. We know the value of  $R_L$ , which is the load resistance, but do not know the value of the plate resistance  $R_P$ . However, we do know that we apply 200 volts to the plate circuit, which means that  $E$  is equal to 200 volts. By means of a current meter, we check the current and find that it amounts to .00036 ampere, which is the equivalent of 360 microamperes or .36 milliampere. The entire resistance of the circuit, then, is in accordance with Ohm's Law:

$$R = \frac{E}{I} = \frac{200}{.00036} = 555,555 \text{ ohms}$$

We assume a value of 150,000 ohms for  $R_L$ . Then the value of  $R_P$  must be the difference between the total resistance of 555,555 ohms and 150,000 ohms or 555,555 minus 150,000 equals 405,555 ohms. That is the value of  $R_P$  or the plate resistance of the tube. In accordance with these figures, the voltage drop across the load resistance is

$$E_{RL} = I \times R_L = .00036 \times 150,000 = 54 \text{ volts}$$

and the voltage drop across the plate resistance  $R_P$  is

$$E_{RP} = I \times R_P = .00036 \times 405,555 = 146 \text{ volts}$$

The sum of the voltage drops across  $R_L$  and  $R_P$  equals the voltage applied, that is,

$$E_{app.} = IR_L + IR_P = 54 + 146 = 200 \text{ volts}$$

Now we come to a subject which you no doubt have heard discussed, or which you have seen in print, namely the effective voltage at the plate terminal of a vacuum tube. If we correlate Figs. 25 and 26, and recognize that 150 volts are dropped across  $R_L$  in Fig. 25, the effective voltage at the plate of the tube shown in Fig. 25 is not the B supply voltage of, say 200 volts, but only 50 volts. . . . *In other words, the effective plate voltage is invariably less than the voltage of the B supply source because of the voltage drop which takes place across the device located in the plate circuit*—in this case the resistor  $R_L$ .

Obviously, the higher the value of the load resistance, the less the total current flowing in the plate circuit and the lower the plate voltage effective at the plate. As it happens, the design of vacuum tube circuits used for voltage amplification is such that the maximum value of load resistance ( $R_L$ ) is desired, yet, there is an optimum value for this resistance which will provide the required amount of effective plate voltage consistent with maximum transfer of signal voltage from the tube to the load. . . . This subject will receive special attention in another volume of this "An Hour a Day With Rider" series.

### Plate Circuit Measurements

As far as we are concerned at this time, the subject of importance is the distribution and measurement of d-c. voltages within this tube circuit. No doubt you have had occasion, in the past, to establish the d-c. voltage drop across the load resistance in a vacuum tube circuit. And more than likely, the first test you made was not productive of the information desired, because the voltmeter read backwards and it was necessary to reverse the polarity of the instruments. . . . An occurrence of this kind is quite commonplace, because it is the natural impulse to connect the plus side of the voltmeter to the end of the load resistance nearest the plate of the tube and the minus side of the voltmeter to the end of the load resistance nearest the B supply. . . . The reason for this is that it is natural to assume that the end of the load resistance nearest the plate, which we all understand to be positive, is positive. . . . However, you forget that the plate of the tube is positive only with respect to the negative end of the B voltage supply source, or with respect to the filament or cathode. . . . The polarity of the tube is negative with respect to the plus side of the B voltage supply source, consequently the end of the load resistance nearest the plate likewise is negative with respect to the plus end of the voltage supply source, and the end of the load resistor nearest the B voltage supply source is positive rather than negative. This is in accordance with the polarity indicated for  $R_L$  in Fig. 26.

No doubt you are also surprised to note the discrepancy between the voltage existing across the minus side of the B supply

and the plate, and the voltage rating of the B supply source. . . . This is quite natural, since there is a voltage drop across the resistance  $R_L$ . . . . In some cases the discrepancy is not great and in others it is quite substantial. The extent of the discrepancy is generally controlled by the voltage drop across the load resistance. If the load resistance  $R_L$  is of a high value, then the voltage drop across it is appreciable. On the other hand, if the load resistance is the d-c. resistance of a transformer winding or a choke, then the voltage drop across it is much less. . . . The

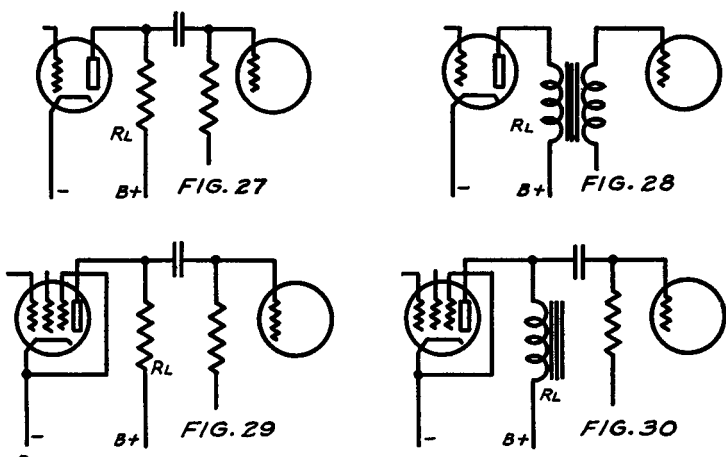

*Figs. 27, 28, 29, and 30. In each of these circuits  $R_L$  is the load resistance in the tube plate circuit. Compare Fig. 26.*

higher the value of the load resistance with respect to the internal plate resistance, the less is the d-c. voltage existing between the minus terminal of the B voltage supply source and the plate of the tube. A measurement of this kind is the equivalent of a voltage test across  $R_P$  in Fig. 26. The voltage existing between the plate of the tube and the minus end of the B voltage supply source is the equivalent of the voltage drop across  $R_P$  in Fig. 26.

As far as a resistance in the external plate circuit is concerned, the electrical diagram shown in Fig. 26 is identical to the circuits shown in Figs. 27, 28, 29, and 30. In each and every case,  $R_L$  is the d-c. resistance of the device connected in the ex-

ternal plate circuit and used as the load resistance. (When viewed from the angle of alternating currents, these devices would represent the plate load impedance.) In Fig. 28,  $R_L$  is the d-c. resistance of the transformer primary, and in Fig. 30,  $R_L$  is the d-c. resistance of the choke.

It might be well at this time to add that our discussion, as it relates to d-c. voltage distribution, current flow and voltage drop, applies, irrespective of the function of the vacuum tube, that is, its use in a receiver as an amplifier or rectifier,—its use in a transmitter as an amplifier, oscillator,—as a special func-

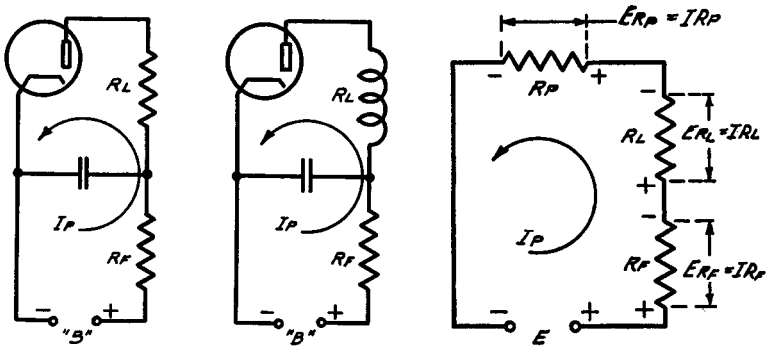

*Figs. 31, 32, and 33, left to right. A filter resistance,  $R_F$ , has been added to the basic circuits of Figs. 27 to 30. The condenser can be neglected in any calculations, as it does not affect the d-c. voltage distribution. Fig. 33 is the electrical equivalent of Figs. 31 and 32.*

tion tube, such as a tuning indicator, automatic volume control, etc. The same applies with respect to frequencies. We are not concerned with the frequency of the signal voltages fed to the various circuits and the signal currents flowing in the circuits. Our primary concern is with the direct currents and d-c. voltages in connection with operating potentials.

An elaboration of the basic simple structure, shown in Figs. 25 and 26, is that shown in Fig. 31, wherein the external plate circuit contains the load resistance  $R_L$  and a filter resistance  $R_F$ . This circuit is identical to that shown in Fig. 32, wherein  $R_L$  is the d-c. resistance of a winding of some kind, whatever it may happen to be. An electrical equivalent of this system is shown

in Fig. 33, wherein  $R_P$  is the plate resistance,  $R_L$  is the load resistance, and  $R_F$  is the filter resistance. The condenser illustrated in Figs. 31 and 32 does not play any part in the distribution of the d-c. voltages or in connection with direct current flow.

If you examine Fig. 33 you will find that it is essentially the same as the basic series circuit shown in Figs. 19 and 21. The function of the filter resistance  $R_F$  is to isolate the plate voltage supply source from the remainder of the plate circuit with respect to alternating signal currents which flow in the plate circuit. However, as far as d-c. distribution and direct current are concerned, this resistor carries current and consequently a voltage drop is developed across this resistance. The current in the circuit is

$$I = \frac{E}{R_P + R_L + R_F}$$

and the voltage drop across the respective units is

$$\begin{aligned} E_{RP} &= I \times R_P \\ E_{RL} &= I \times R_L \\ E_{RF} &= I \times R_F \end{aligned}$$

and the voltage existing between the plate and the negative side of the B supply voltage being equal to the voltage drop across  $R_P$ , is

$$E_{RP} = E_{app.} - (E_{RL} + E_{RF})$$

The polarities of the series voltage drops in this circuit are in accordance with what was said in connection with Figs. 25 and 26.

We have spoken of  $R_F$  as being a filter resistor. It is perfectly possible that this unit is a voltage dropping resistor, which is intended to drop a certain amount of voltage, so that the voltage at the plate of the tube will be correct, despite the fact that the B supply is much greater than the voltage required. For example, the required voltage at the plate is 90 volts, at which time the rated plate current is .5 milliamperere or .0005 ampere. We assume that the available B voltage is 200 volts. We know that in the case of Fig. 31, the load resistance  $R_L$  is supposed to be 100,000 ohms. This much resistance is actually required as determined by the design of the circuit. We know that we must

drop 110 volts, or the difference between the required voltage at the plate and the available voltage at the B supply, or  $200 - 90 = 110$  volts. According to Ohm's Law, the resistance required to drop 110 volts is

$$R = \frac{E}{I} = \frac{110}{.0005} = 220,000 \text{ ohms}$$

However, the plate load resistor is 100,000 ohms, so that the additional voltage dropping resistor required in the circuit is the difference between the total resistance required and that already in the circuit, namely,  $220,000 \text{ ohms} - 100,000 \text{ ohms} = 120,000$  ohms. The same method of calculation applies to Fig. 32, although we must recognize that the ohmic value of a transformer or choke winding is less than that of the usual plate load resistor and that under such conditions, the ohmic value of  $R_F$  is higher so as to establish the proper drop in the circuit.

### Bias Circuits

It is quite a commonplace occurrence to establish the control grid bias voltage by means of a voltage drop developed across a resistance through which is passed the plate current of the tube. An example of this is shown in Fig. 34. Essentially this is the same circuit as shown in Fig. 25, except for the addition of a resistor in the cathode circuit. Let us trace the current flow through the circuit in order to establish the polarity of the terminals of this cathode resistor and, consequently, the polarity of the voltage drop.

We know that electric current flow in a vacuum tube is from the plus side of the circuit to the minus side of the circuit, which means that electric current flow is from the plus terminal of the battery B, shown in Fig. 34, through the resistor  $R_L$ , from the plate to the cathode and then down through the resistor  $R_K$  to the minus terminal of the battery.

In accordance with the direction of the current flow described, the top of  $R_K$ , or the end which is connected to the cathode, is *positive with respect to the bottom of the unit, or the end of the unit which is joined to the minus terminal of the B battery*. This is so despite the fact that we normally interpret

the cathode of the tube as being negative with respect to the plate of the tube. The electrical equivalent of the circuit shown in Fig. 34, is illustrated in Fig. 35, wherein  $E$  is the source of voltage,  $R_L$  is the plate load resistor,  $R_P$  is the plate resistance of the tube, and  $R_K$  is the cathode bias resistor. The arrows indicate the direction of current flow through the circuit. Based upon this direction of current flow, the polarities of the ends of the resistors, which means the voltage drop across these resistors, are as shown by means of the various plus (+) and minus (-) signs.

The purpose of the cathode resistor  $R_K$  is to develop a certain voltage, which is then applied to the control grid of the tube (not shown in this illustration) as the control grid bias. Accordingly, we start off with the knowledge of the voltage required. Furthermore, we usually know the amount of current which flows in the

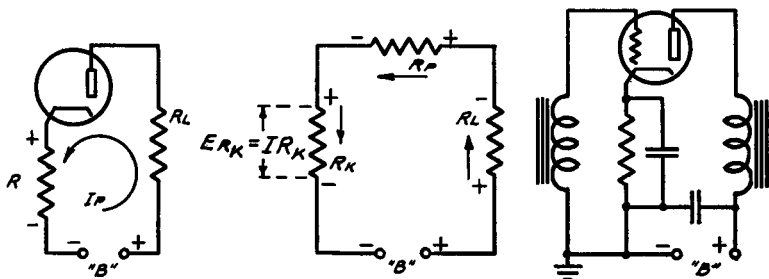

**Figs. 34, 35, and 36, left to right. In order to obtain grid bias, a resistor is connected in the cathode circuit, this being  $R_K$  in Figs. 34 and 35. The latter is the electrical equivalent of the former. Fig. 36 shows how the bias can be applied to the grid of a tube.**

circuit, that is, the amount of plate current. The desired information is, as a rule, the value of the resistance required to develop the desired voltage drop. The value is established by the ordinary application of Ohm's Law. For example, suppose that we desire a control bias of 5 volts. We know that the plate current in the tube, when the proper bias is applied and the correct operating voltages exist, is 10 milliamperes or .01 ampere. According to Ohm's Law, the resistance required to develop 5 volts at .01 ampere is

$$R = \frac{E}{I} = \frac{5}{.01} = 500 \text{ ohms}$$

There are a number of other methods in which bias voltage is automatically secured, but since some of them are related to parallel circuits rather than series circuits, we will hold the discussion of such systems in abeyance until such time as we discuss parallel systems. The method of applying such a bias voltage to the control grid of a tube is illustrated in Fig. 36.

If you will refer back again to Fig. 35 and examine the polarities indicated across the respective resistors, you will note that measurement of the voltage drop across  $R_K$  requires that the plus end of the voltmeter be joined to the cathode of the tube and that the minus end of the voltmeter be connected to the minus end of the voltage supply  $E$ . This is so even if the minus end of the voltage supply  $E$  is connected to ground, as shown in Fig. 36.

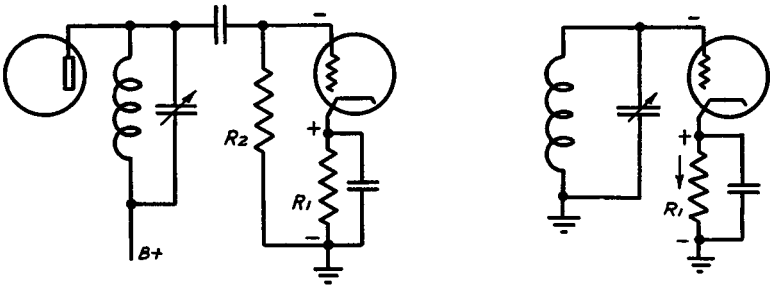

*Fig. 37, left, Fig. 38. In finding the voltage developed across  $R_1$ , Fig. 37, the plate current is used, but  $R_2$  does not enter into the calculations, as it is assumed that no current flows between the grid and the cathode. Fig. 38 shows another variation of this circuit.*

If you now desire to check voltages across the respective units in the circuits of Figs. 34 and 36 with the minus end of the voltage supply source  $B$  as the reference point, then the voltage existing between the minus end of the voltage supply source and the cathode is that which is developed across the cathode resistor. . . . The voltage existing between the minus end of the voltage supply source and the plate of the tube is the sum of the voltage drops across the internal plate resistance and the cathode



bias resistor. The voltage across the minus and plus terminals of the B supply source is, naturally, the sum of all of the drops and requires no further discussion.

A modification of the circuit shown in Fig. 36 is shown in Fig. 37, wherein the bias voltage developed across R1, the cathode resistor, is applied to the control grid of the tube through a grid leak or grid resistor R2. As far as the calculation of the cathode bias resistor R1 is concerned, the value of R2 is not of any importance, because it is assumed that direct current flow does not exist between the control grid and the cathode circuit. The current flow which develops the control grid bias across the bias resistor R1 is the plate current of the tube. Another variation of the basic circuit shown in Fig. 36 is that shown in Fig. 38.

Referring to Figs. 37 and 38, the polarity of the voltages is as shown in the illustrations. In each case the control grid is (—) with respect to the cathode, which is (+). In each case, as is evident, the control grid is at the same potential as ground. This may appear strange in the case of Fig. 37, because of the resistor R2. It is true, nevertheless, because there being no current flow through R2, there is no voltage drop across the element and the potential and polarity remain the same all along R2.

However, the presence of R2 in Fig. 37 does influence voltage measurement, that is the measurement of the control grid bias existing between the control grid and the cathode. The reason for this is the fact that current is required by the voltmeter and when such a measurement is made with the voltmeter connected between the control grid and the cathode, the meter current flows through R2 and consequently a voltage drop appears across this device. As the result of this voltage drop, the voltage measured between the control grid and the cathode is appreciably less than the actual control bias voltage developed across R1.

Another variation of the basic control grid bias circuit, such as shown in Fig. 36, is that illustrated in Fig. 39, wherein a resistor R is in series with C-bias battery, CB. Such a circuit is often used in transmitting systems, wherein the C-bias battery supplies the basic bias and, as the consequence of driving the control grid positive by the application of sufficient signal voltage, direct current flows between the control grid and the cathode. This current, which in reality is rectified current,

causes current flow through the grid resistor  $R$  in the direction shown by the arrow, and the polarities, which exist across  $R$ , are as indicated in Fig. 39. The voltage drop which then appears across  $R$ , is in the same direction as the polarity of the voltage of the C-bias battery  $CB$ , and the actual bias voltage effective upon the control grid is the sum of the voltage developed across

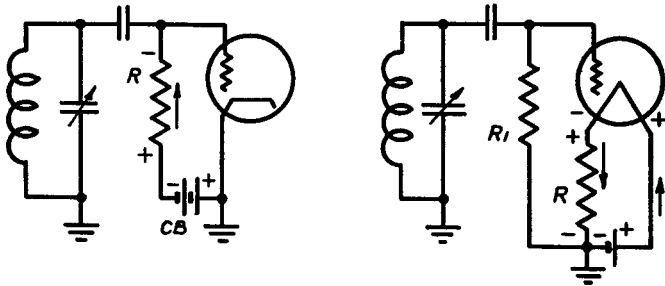

*Fig. 39, left, Fig. 40. Another variation of Fig. 36 is shown in Fig. 39, wherein the bias resistor is in series with the C battery,  $CB$ . In Fig. 40,  $R$  is the bias resistor and  $R_1$  is the grid resistor through which the bias is fed to the grid.*

resistor  $R$  and the C-bias battery voltage. The calculation of the value of  $R$  in such a system is in accordance with the normal applications of Ohm's Law for resistance, viz:

$$R = \frac{E}{I}$$

wherein  $R$  is the required value of the grid resistor,  $E$  is the additional voltage which must be developed across  $R$  so that the sum of this voltage and the voltage of the C-bias battery  $CB$  will total the required amount, and  $I$  is the grid current during such operation. The grid current is, of course, expressed in terms of amperes, so as to enable proper use in the Ohm's Law equation.

The application of Ohm's Law to simple control grid bias circuits, as found in d-c. systems, is illustrated in Figs. 40 and 41. In Fig. 40,  $R$  is the biasing resistor, whereas  $R_1$  is the grid resistor through which is applied the control grid bias voltage. The latter does not appear in these calculations. The value of

$R$  is established in the regular routine manner, wherein  $R$  is the desired resistance,  $E$  is the required bias voltage, and  $I$  is the filament current flowing through resistor  $R$ .

As shown in Fig. 40, the direction of the filament current through resistor  $R$  is down through the unit, so that the end of the resistor  $R$  nearest the minus terminal of the A battery is ( $-$ ), and the end of the resistor  $R$  nearest the filament is ( $+$ ). Consequently, by connecting the grid resistor  $R_1$  to the minus end of the bias resistor, a difference of potential is established between the control grid and the filament, which makes the control grid negative with respect to the negative end of the filament by the amount of the drop across  $R$ .

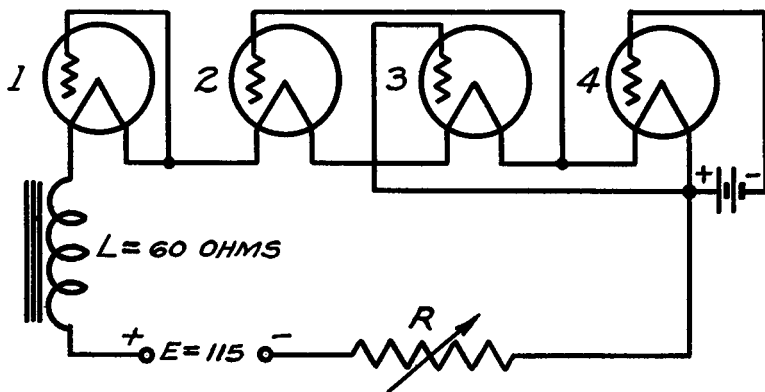

Fig. 41. The basic filament and control grid circuits of a simple d-c. receiver. Note the connections to the grids.  $R$  is the filament control resistor and  $L$  is a 60-ohm choke.

While it is true that the filament itself is a resistance and a voltage drop takes place across this resistance, this drop is not considered in connection with bias values, because the *negative point of the filament is taken as the reference point*. In other words, the control grid is made negative by a certain amount with respect to the negative end of the filament. Thus, if the filament current is .25 ampere and a bias voltage of 3 volts is required, the equation becomes

$$R = \frac{3}{.25} = 12 \text{ ohms}$$

In Fig. 41 is shown the basic filament and control grid circuits of a simple d-c. receiver, which can serve as an example of the methods employed in more elaborate d-c. receiver systems. All bypass condensers have been omitted, because they do not enter into the discussion. The control grid circuits of the various tubes are shown connected to certain points in the system without reference to the transformers or other windings which may be part of the control grid system. Each of these filaments is assumed to be operating at 2 volts and .25 ampere. Resistor R is the filament control resistor, whereas the choke L is a filter choke rated at 60 ohms. The voltage supply E equals 115 volts.

If we replace the filaments with equivalent resistances and also show a resistance in place of the choke L, the circuit will appear as shown in Fig. 42, wherein R is the control resistor,

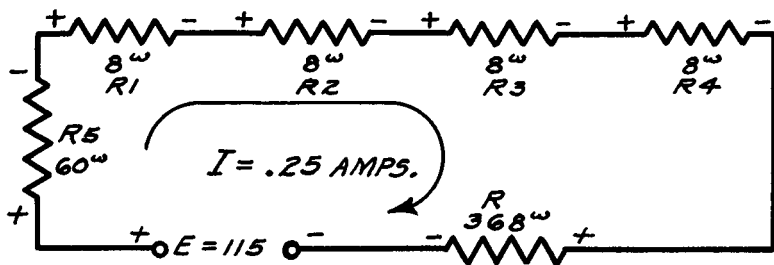

*Fig. 42. Equivalent values of resistance are here substituted for the four filaments, the choke, and the control resistor of Fig. 41. Note the polarities indicated and compare with Fig. 41.*

R1 is the filament of tube No. 1, R2 is the filament of tube No. 2, R3 is the filament of tube No. 3, R4 is the filament of tube No. 4, and R5 is the resistance of the choke L. According to the voltage and the current ratings of the respective filaments, the values of R1, R2, R3, R4, are equal to

$$R1 = \frac{E}{I} = \frac{2}{.25} = 8 \text{ ohms}$$

and since all the ratings are the same  $R_1 = R_2 = R_3 = R_4$ . The value of  $R$  required to maintain the current through each of these filaments at .25 ampere, is determined by establishing the relative  $R_1, R_2, R_3$  and  $R_4$  voltage drops, each at .25 ampere, and the drop across the filter choke. In a series circuit the voltage drops are additive, so that the voltage drop across the four filaments is the sum of the drop across each filament—which makes a total of eight volts. The drop across the 60-ohm filter choke is equal to

$$E = I \times R = 60 \times .25 = 15 \text{ volts.}$$

The sum of the voltage drops across the filaments and the filter choke is  $8 + 15$ , or 23 volts. Accordingly the resistor  $R$  must drop or dissipate an amount of voltage equal to the difference between the available voltage and the total drop across the filaments plus the filter choke. This is,

$$115 - (2 + 2 + 2 + 2 + 15) = 92 \text{ volts.}$$

The resistance required then is

$$R = \frac{E}{I} = \frac{92}{.25} = 368 \text{ ohms.}$$

Since the current flow in the circuit is from the positive to the negative side, the polarity of the respective voltage drops is as shown in Fig. 42. . . . So much for the filament circuit. Let us now consider the bias systems.

*Fig. 43. The various IR drops of the resistances in Fig. 41 are indicated on the respective units. The method of calculating these drops is explained in the accompanying text.*

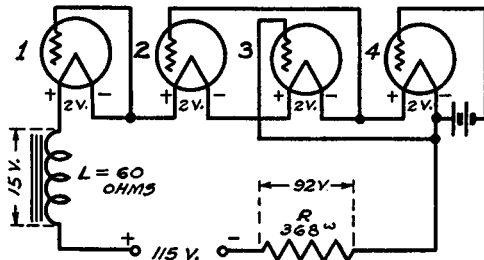

In Fig. 43 is shown the evolution of Fig. 42 inclusive of the polarities and values of the voltage drops across the various elements and the grid circuit connections. We stated that 2.0 volts

is the drop across each of the filaments. As far as distribution of the bias voltage is concerned, the voltage drops across the filter choke and control resistor are of no consequence. Now it is accepted convention to assume that the control grid is biased with respect to the negative side of the filament, which means that as far as the control grid bias for any one particular tube is concerned—if the control grid of a tube is connected to the minus end of the filament, that control grid is assumed to be operating at zero potential. . . . This is shown in connection with tube No. 1, wherein the control grid is joined to the minus side of the filament of that tube. No doubt, you appreciate that a voltage drop of two volts does occur across this filament and that if the control grid voltage were considered with respect to the positive side of the filament, then the connection, as shown, would apply a two volt negative bias to this control grid.

In order that tube No. 2 have a two volt negative bias, it is necessary to connect the control grid lead to the (—) end of the filament in tube No. 3. The reason for this is that the (—) end of No. 3 filament is two volts negative, or lower in potential than the (—) end of No. 2 filament. This becomes evident when you analyze the relation between No. 2 filament and No. 3 filament. The (—) end of No. 3 filament is two volts (—) with respect to the (+) end of No. 3 filament. However, the (+) end of No. 3 filament is common with the (—) end of No. 2 filament. Furthermore, all parts of the circuit to the left of the (—) point on No. 3 filament are (+), despite the fact that in each case, each point has a dual polarity. Consequently, by connecting the control grid of the No. 2 tube to the (—) end of the No. 3 filament, the control grid of No. 2 tube is two volts negative with respect to the negative point of the No. 2 filament.

If a voltage measurement were made to establish the bias voltage existing between the filament and the control grid of tube No. 2, the negative end of the voltmeter would be connected to the control grid of tube No. 2 and the positive end of the voltmeter would be connected to the negative side of tube No. 2 filament. The indication would then be the voltage drop across tube No. 3 filament. If, by chance, the positive end of this voltmeter were connected to the positive end of tube No. 2 filament, then the indication would be the sum of the voltage drops across the No. 3 filament and the No. 2 filament.

As far as tube No. 4 is concerned, it secures its bias from a C-bias battery, and the bias existing upon the control grid is then the voltage of this battery, as measured between the control grid of the tube and the (—) side of tube No. 4 filament. Once again, if the reference point is taken as the (+) end of tube No. 4 filament, the bias voltage, between the control grid and the plus side of tube No. 4 filament, is the sum of the C-bias battery voltage and the voltage drop across tube No. 4 filament.

**Lest you forget, we again repeat that the accepted convention in d-c. operated circuits is that the minus end of the filament is the reference point, and that all control grid bias voltages are with respect to the negative end of the filament.**

As far as biasing of circuits is concerned, we would like to make the comment that the nature of the device, which is located in the grid circuit, is of no consequence as far as the actual distribution of the bias voltage is concerned, provided that a steady value of direct current can flow through the device. As has been mentioned, the only time that the nature of this device becomes important is when measurement of the bias voltage is

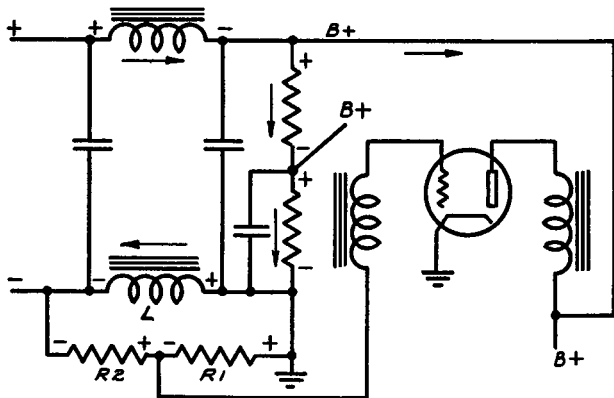
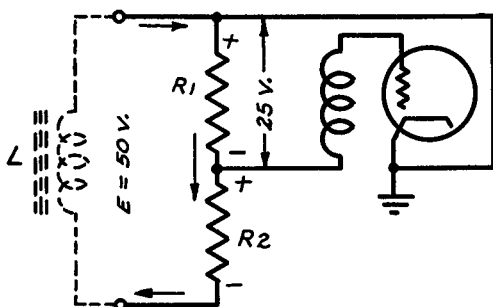

*Fig. 44. The voltage distribution system for a power pack. The tube here shown can be considered to be in the output a-f. stage.*

made between the control grid and whatever other point in the system is the reference point. Even then low d-c. resistance units, such as r-f., i-f. and a-f. transformers, as a rule, will not influence the voltage reading when made with proper types of

equipment. High values of resistance, such as grid leaks or grid resistors ranging from 50,000 ohms and up, will influence the indication upon a voltmeter.

An elaboration of a bias arrangement, as far as it applies to d-c. voltage distribution, is that shown in Fig. 44. This illustration shows a portion of a power supply circuit. The items which interest us are the choke  $L$  and resistors  $R_1$  and  $R_2$ , also the ground connection. It is assumed that the input to this complete filter system is connected across a source of d-c. voltage with the polarity shown, so that the current flow is as indicated by the arrows and the polarities of the respective voltage drops



*Fig. 45. In this revised diagram of Fig. 44, the coil  $L$  is considered to be the source of voltage, which is permissible upon comparison with the former figure. Note the grounding of the cathode, which is positive with respect to the grid.*

are as shown in the illustration. Continuing, we are concerned with the voltage drop which develops across choke  $L$  with the polarity shown and with the presence of the voltage divider,  $R_1$ - $R_2$ , connected across this choke  $L$ . For our purposes, we can assume  $L$  to be a source of d-c. voltage with the polarities shown, and from this point on, we can discuss how such a circuit is used to supply the control grid bias for certain tubes in radio receivers and amplifiers and how voltage measurements are made.

It is significant to note in Fig. 44 that the control grid is connected to the voltage divider  $R_1$ - $R_2$ , and that the (+) side of  $R_1$  is connected to ground. This means that ground is positive with respect to the most negative point in the system. It is also significant to note that the cathode of the tube is also connected to ground and consequently is positive with respect to the most negative point in the system. A revised diagram of Fig. 44 is shown in Fig. 45, wherein  $L$ , shown in dotted lines, becomes a



source of voltage and R1-R2 constitutes a voltage divider across this source of voltage. The direction of the current flow through the voltage divider is in such direction that the polarities indicated exist. In Fig. 45 we have joined the cathode of the tube to the plus side of R1. This is permissible, because, if you examine Fig. 44, you will find that the plus side of R1 goes to ground and the cathode of the tube goes to ground, so that they are electrically at the same potential. If you now examine Fig. 45, you will note that the control grid is at a lower potential than the cathode by a value equal to the voltage drop across R1. When we say "lower" we mean negative. In other words, if the voltage E, available across choke L in Fig. 44, is 50 volts, and R1 and R2 are of equal value, then the available voltage divides equally between R1 and R2—which means that a drop of 25 volts is available across R1 and the polarity of this voltage is such that the control grid of the tube is 25 volts minus with respect to the cathode of the tube; or, expressed in another manner, the cathode is 25 volts plus with respect to the control grid of the tube.

To measure voltage in such an arrangement, the measurement would be made between the control grid and the cathode, with the positive side of the voltmeter connected to the cathode and the negative side of the voltmeter joined to the control grid.

When establishing the voltage drop across the voltage divider R1-R2, it is not necessary actually to compute the current flow through the divider. Irrespective of what the voltage across choke L in Fig. 44 is, which means the available voltage E in Fig. 45,—that voltage will appear across the elements of the divider and will be divided in accordance with the respective values of the elements in the divider. . . . The manner in which this voltage divides has already been discussed. If you will refer back to the text relating to Figs. 16, 19 and 21, you will find various references to such division. In the event that you are interested in the simple mathematical expression concerning such division as it applies to Fig. 45, *the voltage across any one section bears the same relation to the whole voltage, as that section bears to the resistance of the entire divider.* For example, the voltage across R1 is

$$E_{R_1} = \frac{R_1}{R_1 + R_2} \times E$$

and the voltage across R2 is

$$E_{R_2} = \frac{R_2}{R_1 + R_2} \times E$$

For example, if the available voltage is 50 volts and R1 has a resistance of 40,000 ohms, and R2 has a resistance of 10,000 ohms, then

$$E_{R_1} = \frac{40,000}{40,000 + 10,000} \times 50 = 40 \text{ volts}$$

and

$$E_{R_2} = \frac{10,000}{40,000 + 10,000} \times 50 = 10 \text{ volts}$$

The foregoing discussion of grid bias voltages, secured from power supply systems and wherein the grounded portion of the receiver is at a potential higher than the most negative portion of the receiver, is an example of what was mentioned earlier in this text concerning the possibility of establishing ground at a higher potential than the most negative point in a receiver. We refer you to Fig. 21 and the discussion relating thereto.

Of course if you wish to compute current flow through the divider and then select the values for the divider, it is possible to do so with very little additional effort. Inasmuch as the voltage available, that is, the voltage across choke L, is known, it can be considered as being a source of voltage of that value. Let us assume this to be 50 volts. Inasmuch as current does not flow in the grid circuit,—that is, it is not supposed to flow in the grid circuit during normal operation of the amplifier system, it is possible to employ high values of resistance for the voltage divider. A total resistance for this divider of 100,000 ohms is satisfactory. Based upon the available voltage, the current flow through the entire divider then is

$$I = \frac{E}{R} = \frac{50}{100,000} = .0005 \text{ ampere}$$

If the required value of voltage is, say, 10 volts, then the portion of the divider, which is supposed to supply this drop, can be determined by the equation

$$R = \frac{E}{I} = \frac{10}{.0005} = 20,000 \text{ ohms}$$

This means that the voltage drop across 20,000 ohms of this 100,000-ohm total resistance will provide the 10-volt drop. Naturally, it is not logical to tap a 100,000-ohm resistor at 20,000 ohms, unless a type of resistance is used that allows a tap. A more logical step is to use a 20,000-ohm resistance in series with an 80,000-ohm resistance, in order to comprise the divider of 100,000 ohms and arrange a tap upon the junction between these two resistances. The arrangement of this divider is in such manner that the 20,000-ohm resistance is adjacent to the most positive point of the system and the 80,000-ohm resistance is adjacent to the most negative point of the system. In other words, the 20,000-ohm tap occupies the position of R1 in Fig. 44, and the 80,000-ohm resistance occupies the position of R2 as shown in Fig. 44.

It might be well if we give another example of the manner in which bias voltages are secured from the power supply system in what is actually a series circuit arrangement. Fig. 45-A shows a power supply system wherein the voltage divider consists of the four resistors, R1, R2, R3, and R4. The direct current flow through the circuit is as indicated in the diagram, and the polarities of the voltage drops across these various resistors are also indicated. The two B+ terminals apply B voltage to the tube plates, as shown, and the current flow is indicated.

If you examine Fig. 45-A, you will find that the junction between R2 and R3 is connected to ground and one polarity sign is a plus (+) sign and another polarity sign is a minus (—) sign within a circle. The minus (—) sign identifies the polarity of this ground connection with respect to the resistors R1 and R2,—which means the B voltage supply circuits. On the other hand, R3 and R4 also have plus and minus signs, but as far as current is concerned, all points along R3 and R4 are minus.

If you now examine the circuits, you will find that the center

tap of the transformer windings, which supply the tube filaments, goes to ground, which means that these points are at the same potential as the ground upon the divider. Accordingly, the filament transformer center taps are plus with respect to R3 and R4,—just as the ground upon the divider is plus with respect to R3 and R4. Since the current flows down through resistors R3 and R4, the terminals C-1 and C-2 are both negative with re-

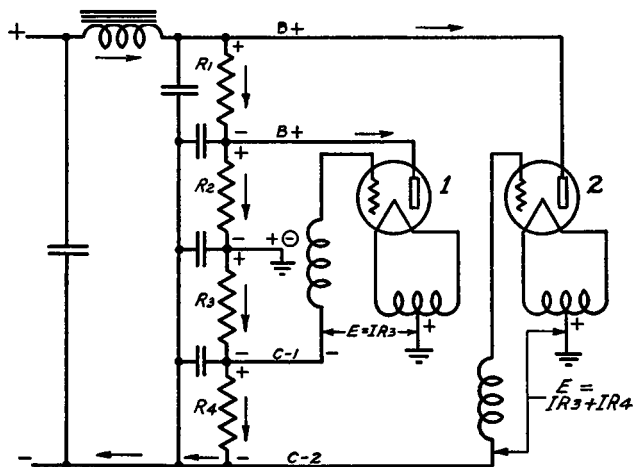

**Fig. 45A.** A voltage divider of four units, R1, R2, R3, and R4. Note the dual polarity of the mid-point, which is grounded, and how the grids are negative with respect to the filaments.

spect to ground; hence if we join the grid of tube No. 1 to terminal C-1, the control grid of tube No. 1 becomes negative with respect to the filament of tube No. 1 by the amount of drop across R3. This is indicated in the diagram by the statement that  $E = IR_3$ .

If we join the control grid of tube No. 2 to terminal C-2, this control grid is then negative with respect to its filament center tap by the sum of the voltage drops across R3 and R4, and this is shown in the diagram by the statement that  $E = IR_3 + IR_4$ .

If you compare Fig. 45-A with Fig. 44, you will find a very definite similarity between the two circuits,—that is, as far as

the C bias is concerned. There are certain differences between the two circuits, but the manner in which these voltages are obtained is substantially identical.

Fig. 46 illustrates the conventional diode rectifier, wherein L and C constitute the tuned circuit feeding the rectifier system; and  $R_L$  is the load resistance. Such a system operates in the conventional manner of a vacuum tube, in that electrons flow

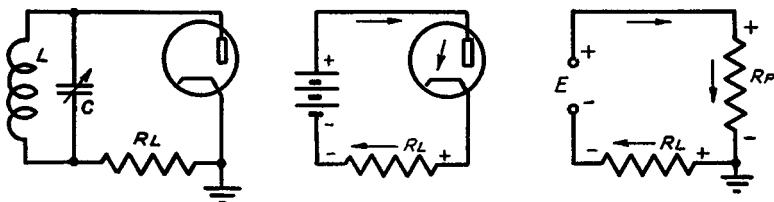

*Fig. 46, 47, and 48, left to right. A conventional diode rectifier circuit, Fig. 46, wherein the tube can be considered as a battery and series resistance, Fig. 47. The electrical equivalent circuit is shown in Fig. 48, with the directions of the current indicated by the arrows.*

between the cathode and the plate during the periods that the plate goes positive with respect to the cathode. The plate goes positive during certain portions of the signal voltage cycles, which are applied across the plate and cathode by the L-C circuit.

When this tube acts as a rectifier it causes the flow of pulsating direct current, so that we are privileged, during the analysis of this system, to assume that the rectifier tube itself is the equivalent of a battery and a series resistance, which battery causes the flow of current through the system in the manner shown in Fig. 47. Interpreting the d-c. resistance existing between the plate and the cathode in Fig. 47 in the form of a resistor  $R_P$ , which resistance is in series with a d-c. voltage supply source, we evolve the circuit shown in Fig. 48, as being the equivalent of Fig. 46. . . .

We recognize that the nature of the direct current flowing through  $R_L$  during operation of the rectifier system is pulsating current, but there is developed across  $R_L$  a value of d-c. voltage, which is the average value of the pulsating voltage and this aver-

age value can be considered as being the voltage that would be secured from a voltage supply source  $E$ , which would provide a constant voltage of the average value previously mentioned. Consequently, we can say that the circuit in Fig. 48 is the equivalent of Fig. 46 during the state of operation of the rectifier.  $R_P$  is the d-c. plate resistance between the cathode and the plate of the rectifier,  $E$  is the voltage supply source, and  $R_L$  is the load resistance. It is common practice to ground the cathode of such diode rectifiers and consequently we show the ground in the electrical circuit.

It is evident that the diode rectifier circuit of Fig. 46, when viewed as shown in Fig. 48, is a simple series circuit and that voltage drops are developed across  $R_P$  and  $R_L$  in accordance with the respective values of these resistances and the current flow in the circuit. It might be well, however, to state that in actual practice the magnitude of the d-c. plate resistance of the diode rectifier is so small with respect to the load resistance, that the voltage drop across the d-c. plate resistance of the tube is negligible. At this time we are not so much interested in the respective voltage drops across  $R_P$  and  $R_L$ —as we are in the polarity of the voltage developed across  $R_L$ .

Based upon the direction of current flow indicated in Fig. 48, the (+) end of  $R_L$  is grounded and all points along  $R_L$  to the left of the plus end are minus with respect to ground. Accordingly, it is possible to tap along  $R_L$  and secure various voltages, which would be negative with respect to the grounded end of the circuit or—when expressed in connection with Fig. 47, it is possible to secure various voltages, which are negative with respect to the cathode. Such is the method used in practice.

An example of such an application is shown in Fig. 49, wherein  $R_L$  is a resistance of 500,000 ohms with a tap at 200,000 ohms.  $R_1$  and  $R_2$  are filter resistors and  $R_3$  and  $R_4$  are bias resistors in the r-f. and i-f. amplifier tube circuits. The automatic bias voltage for the r-f. tube is tapped off  $R_L$  at the 200,000-ohm point, whereas the bias voltage for the i-f. tube is that which is developed across the entire load resistor  $R_L$ . At the same time fixed minimum bias voltages are developed for the r-f. and i-f. tubes by means of the resistors  $R_3$  and  $R_4$ , respectively. Referring to  $R_L$ , let us assume that for a certain signal input to the

diode rectifier, 20 microamperes of direct current, representing the average value of the pulsating current, flows through  $R_L$ . 20 microamperes of current are equal to .00002 ampere and a voltage equal to  $E = I \times R = 500,000 \times .00002$  or 10 volts is developed across  $R_L$ .

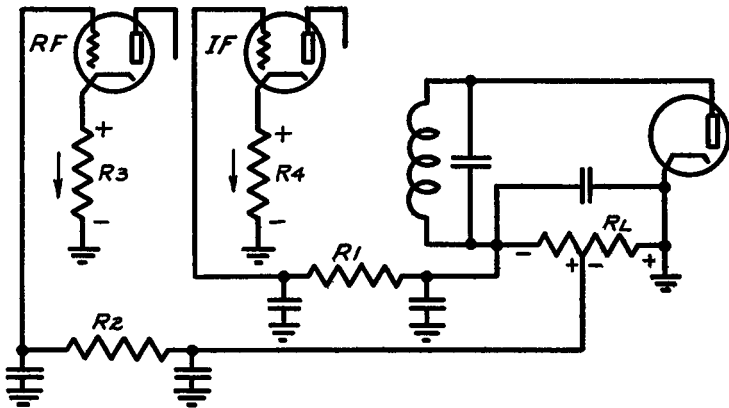

**Fig. 49.** Note how the minimum bias voltages are developed for the grids of the r-f. and i-f. tubes by R3 and R4 respectively. R1 and R2 are filter resistors and so do not enter into the calculations.

Now, if you check the polarity of this voltage developed in the diode circuit you will find that it is in series with the bias voltage developed across R4 by the plate current flowing in the i-f. tube. You will note that the grounded point of R4 is negative with respect to the cathode of R4. This means that if we assume R4 to be a source of voltage with the polarity shown, the (—) end of this source of voltage is connected to ground. Then, if we assume  $R_L$  to be also a source of voltage, we find that the (+) end of this source of voltage is connected to ground. In other words, the (—) side of the R4 voltage is connected to the (+) side of the  $R_L$  voltage, so that we have an arrangement which is the equivalent of that shown in Fig. 50, and the total difference of potential existing between the control grid of an i-f. tube and the cathode of that i-f. tube is the sum of the voltage developed across R4 or,  $E_{R4}$ , and  $E_{RL}$ .

If we assume that the voltage developed across R4 is 2 volts,

then the control grid of the i-f. tube is 12 volts negative with respect to the cathode of that tube.

Referring once more to  $R_L$ , we stated that the bias voltage for the r-f. tube was developed across the 200,000-ohm portion of  $R_L$ , and in accordance with the 20 microamperes of current, which is said to flow through  $R_L$ , a voltage equal to 4 volts is the automatic bias voltage which is applied to the control grid of the r-f. tube. What was said in connection with the series arrangement of the i-f. bias voltage is true with respect to the r-f. bias voltage, except that in this case the voltage developed across  $R_3$  is in series with the voltage developed across the 200,000-ohm

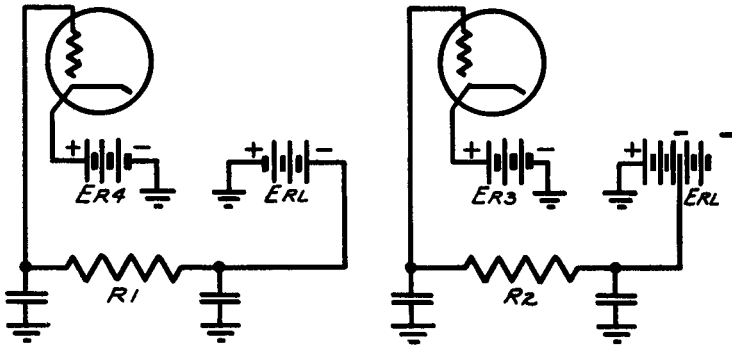

*Fig. 50. The voltages developed across the bias and load resistors in Fig. 49 are shown here as batteries. Note the polarities.*

portion of  $R_L$ . The control grid of the r-f. tube is negative with respect to its cathode by the sum of the voltages developed across  $R_3$  and across the 200,000-ohm portion of  $R_L$ . As in the case of the i-f. tube, the minimum bias developed across  $R_3$  is that due to the plate current flowing in that tube.

The filter resistors  $R_1$  and  $R_2$  have no bearing upon the distribution of the voltages. Their function in each case is to isolate the diode circuit from the control grid circuit and to remove any possible fluctuations in voltage due to the audio-frequency component which is present in the voltage developed across  $R_L$ .



## Chapter IV

### PARALLEL AND SERIES-PARALLEL CIRCUITS

In addition to the series circuit described in the preceding pages, we also have two other arrangements of electrical units. One of these is the parallel arrangement and the second is the series-parallel arrangement. We are going to deal with each of these arrangements individually and at the present moment will focus our attention upon the parallel circuit.

The distinction between circuit arrangements is found in the manner in which current flows through the circuit. If you remember, we stated that a series circuit was one in which there was but one path for the current, and that the current was the same in all parts of the circuit. On the other hand, the rule governing parallel circuits states:

*A circuit which has two or more paths connected between the same two points, is known as a parallel circuit.*

Such a circuit is shown in Fig. 51, wherein resistances  $R_1$  and  $R_2$  are connected between the same two points in the system. As in the case of series circuits, parallel circuits are not necessarily limited to the use of pure resistors. In other words, a parallel circuit may consist of a resistor in parallel with a coil or vice versa, as shown in Fig 52, where  $R$  is the resistor and  $L$  is the coil. There are, of course, various combinations of condensers as well as resistors and coils which can be classified as being parallel combinations, but since we are interested primarily in those units which allow the flow of direct current, we omit the condenser.

As far as direction of current flow is concerned, what has been said in connection with series circuits, namely that the current flows from the positive end of the circuit to the negative end, is illustrated in Fig. 51 by the direction of the arrows. If we

momentarily neglect resistance  $R_2$  and consider resistance  $R_1$  only, then the current, due to the voltage  $E$  through resistance  $R_1$  is

$$I_1 = \frac{E}{R_1}$$

As far as this resistor is concerned, with respect to the voltage source, the two combine to form a series circuit.

If we now neglect resistance  $R_1$  and consider resistance  $R_2$ , we again note a simple series circuit where the current through  $R_2$  is

$$I_2 = \frac{E}{R_2}$$

An analysis of these two equations brings one important item to light: namely that the same voltage acts upon both resistances. This gives rise to a law relating to parallel circuits which states that:

*The current flowing through any branch of a parallel circuit is equal to the voltage acting across its terminals, divided by the resistance of the branch.*

This is evident, because the same voltage is acting upon resistance  $R_1$  and  $R_2$  and the current, which flows in these two branches, depends upon the resistance of each branch.

An examination of the circuit in Fig. 51 shows that the terminals of the two resistances in parallel are the points A and B. Each one of these resistances offers a path for the flow of current and is therefore a branch, and the voltage  $E$  is the same across A and B for either one of the two resistances. Since  $R_1$  and  $R_2$  are both in the circuit and it is possible to consider either one individually, the total current flowing into the point A and out of the point B must be the sum of the two currents  $I_1$  and  $I_2$ . If  $I_t$  is the main or total current, and

$$I_t = I_1 + I_2$$

*then the total current through any parallel combination connected between two points in a circuit is equal to the sum of the currents through the branches.*

You can readily understand that the total current  $I_t$  must be

greater when both  $R_1$  and  $R_2$  are in the circuit than when either one of the resistances is removed, and the voltage  $E$  remains constant. Analyzing the circuit, we find that according to Ohm's Law, when  $R_1 = 10$  ohms,  $R_2 = 10$  ohms, and  $E = 100$  volts, then the current through  $R_1$  is

$$I_1 = \frac{E}{R} = \frac{100}{10} = 10 \text{ amperes}$$

and the current through  $R_2$  is

$$I_2 = \frac{E}{R} = \frac{100}{10} = 10 \text{ amperes}$$

therefore

$$I_t = I_1 + I_2 = 10 + 10 = 20 \text{ amperes.}$$

With a constant voltage, it is apparent that if the total current is 20 amperes with  $R_1$  and  $R_2$  in the circuit, and only 10 amperes when either resistance is out, it can be stated that

*The joint resistance of two resistors in parallel is less than the resistance of either one of the individual branches.*

**Fig. 51, left, Fig. 52.** The resistors,  $R_1$  and  $R_2$ , Fig. 51 are in parallel and the arrows indicate the paths followed by the respective currents,  $I_1$  and  $I_2$ , the sum of which is  $I_T$ . In Fig. 52 a coil,  $L$ , is substituted for a resistor, but this does not change the parallel circuit effect.

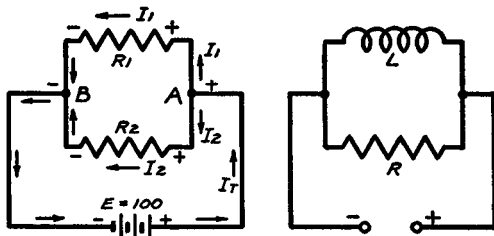

The above rule does not apply solely to two resistances in parallel, that is two branches of a parallel circuit, it applies just as readily to any number of elements connected in parallel. In other words, the *joint resistance of any number of units in parallel is less than the resistance of any one of the branches.*

Under the circumstances it is possible to replace this parallel combination of two resistances with a single element of the

proper value of resistance. This of course applies only from the angle of d-c. voltage distribution and direct current. We most certainly do not mean to imply that it is possible to replace the coil L in Fig. 52 with a resistor and still secure the same type of a-c. operation. However, for an analysis of direct current flow and d-c. voltage distribution, it is possible to replace coil L in Fig. 52 with a resistor and have this resistor in parallel with the other resistor R.

Speaking about parallel circuits and the ability to resolve a combination of two parallel resistances into a single resistance, that also applies to any number of resistances connected in parallel. In other words, it is possible to resolve three or four or more resistances which are connected in parallel, into a single resistance of the proper value. Let us now determine the joint resistance of the simple two element parallel combination shown in Fig. 51. Since the two branch currents are equal to the total current, there must be some value of resistance which causes the flow of the same value of total current. According to Ohm's Law for resistance, the total resistance represented by  $R_1$  in parallel with  $R_2$  then is equal to

$$R_t = \frac{E}{I_1 + I_2} = \frac{100}{10 + 10} = \frac{100}{20} = 5 \text{ ohms}$$

which checks with the rule concerning the joint resistance of resistors in parallel.

We have shown that since the total current is equal to the sum of the branch currents or that  $I_t = I_1 + I_2$ , then the total voltage divided by the total resistance must be equal to the total voltage divided by resistor  $R_1$  plus the total voltage divided by resistor  $R_2$ , or

$$\frac{E}{R} = \frac{E}{R_1} + \frac{E}{R_2}$$

Regardless of the value of E, then

$$\frac{1}{R} = \frac{1}{R_1} + \frac{1}{R_2}$$

which results in the law that:

The joint resistance of a parallel combination of resistances is equal to the reciprocal of the sum of the reciprocals of the resistances constituting the individual branches.

(By the reciprocal of a number is meant one divided by that number. For example, the reciprocal of 10 is one divided by 10, or .1)

Referring to the aforementioned example, the total resistance  $R_t$  of the parallel combination shown in Fig. 52, is

$$R_t = \frac{1}{\frac{1}{R_1} + \frac{1}{R_2}}$$

and if we substitute the numerical values used before, we have

$$R_t = \frac{1}{.1 + .1} = \frac{1}{.2} = 5 \text{ ohms}$$

Let us now elaborate upon what has been said and show the method of computing currents in circuits which involve three resistances in parallel, and when the values of the resistances are

*Fig. 53. The three resistors, R1, R2, and R3, are in parallel. The total resistance is calculated by the method indicated in the text.*

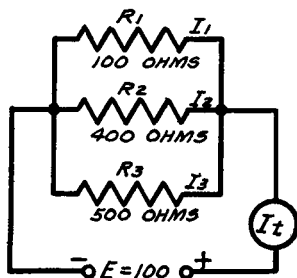

different. For example, in Fig. 53, the applied voltage  $E$  is 100 volts,  $R_1$  equals 100 ohms, and  $R_2$  equals 400 ohms, and  $R_3$  equals 500 ohms. According to the Ohm's Law, the current through  $R_1$  is

$$I_1 = \frac{E}{R_1} = \frac{100}{100} = 1 \text{ ampere}$$

and

$$I_2 = \frac{E}{R_2} = \frac{100}{400} = .25 \text{ ampere}$$

and

$$I_3 = \frac{E}{R_3} = \frac{100}{500} = .2 \text{ ampere}$$

and

$$I_t = I_1 + I_2 + I_3$$

and

$$I_t = 1 + .25 + .2 = 1.45 \text{ ampere}$$

If we solve for the total resistance in accordance with the law relating to reciprocals,

$$R = \frac{1}{\frac{1}{R_1} + \frac{1}{R_2} + \frac{1}{R_3}}$$

and if we substitute numerical values, then

$$R_t = \frac{1}{\frac{1}{100} + \frac{1}{400} + \frac{1}{500}} = \frac{1}{.01 + .0025 + .002} = \frac{1}{.0145} = 69 \text{ ohms}$$

This checks with the determination of the resultant resistance of the parallel combination by the simple application of Ohm's Law, wherein

$$R = \frac{E}{I} = \frac{100}{1.45} = 69 \text{ ohms}$$

There is another method of computing the joint resistance of two resistances in parallel, such as is shown in Fig. 51. This method is much simpler than the use of reciprocals, but unfortunately is limited in its simple state to cases involving only two resistances. However it can be used for more than two resistances by first solving for two resistances and then solving again

for each of the additional resistors. As expressed in the form of an equation, as it applies to two units, the joint resistance of two resistances in parallel is equal to the product divided by the sum. In other words,

$$R_t = \frac{R_1 \times R_2}{R_1 + R_2}$$

If we substitute numerical values as shown in Fig. 51, then

$$R_t = \frac{10 \times 10}{10 + 10} = 5 \text{ ohms}$$

The method of solving the problem shown in Fig. 53 by using the product and sum relation is to determine the joint resistance of  $R_1$  and  $R_2$  first, and then the joint resistance of this resultant value and then  $R_3$ . For example, the joint resistance of  $R_1$  and  $R_2$  is equal to

$$R_{1-2} = \frac{R_1 \times R_2}{R_1 + R_2} = \frac{100 \times 400}{100 + 400} = \frac{40,000}{500} = 80 \text{ ohms}$$

and the joint resistance between this value and  $R_3$  then is

$$\frac{80 \times 500}{80 + 500} = 69 \text{ ohms}$$

This time is just as good as any other to introduce a modification of the normal parallel circuit. . . . It is not essential that the resistance  $R_1$ , or for that matter  $R_2$  or  $R_3$ , be a single unit in order to possess the resistance value specified for the unit,—for example, 100 ohms for  $R_1$  in Fig. 54. Since resistances in series are additive, it is possible to arrange a number of resistances in series, so that the resultant resistance amounts to the required value. . . . Suppose that a 100-ohm resistance is not available, but two other resistors, of 60 and 40 ohms, are available. The two can be connected in series, so as to total the required 100 ohms of the  $R_1$  branch. While it is true that a combination of series and parallel arrangements are used, the circuit is essentially a parallel system. Any number of such units can be arranged to comprise the branches without altering the final arrangement.

Irrespective of the number of units used in each branch, so as to comprise the required total resistance of that branch, the voltage across each branch and the division of the current through each branch takes place exactly as if each branch consisted of but a single resistance of the required

amount. . . . In other words, if the 500-ohm branch consists of four resistors of 88, 12, 125 and 275 ohms respectively, the voltage across that branch and the current through that branch are the same as if the branch consisted of a single 500-ohm resistor.

### **Polarity of the Voltage Drop in Parallel Circuits**

The fundamental laws governing the polarity of the voltage drop in series circuits is applicable in its entirety to parallel circuits. The electric current flows from plus to minus and the polarity of the voltage drop is shown in Fig. 51. The end of the elements, at which the current presumably enters, is the positive end, and the end, where it presumably leaves, is negative. . . . For a more detailed explanation, we suggest that you refer back to the theory covering the series circuit, with particular reference to the polarity of the voltage drop in series circuits.

### **Series-Parallel Circuits**

Having discussed the series circuit and the parallel circuit as individual systems, we are now ready to combine these two systems and discuss the circuit which is very common in actual practice, namely,—series-parallel arrangements. . . . While it is true that series arrangements are quite common, parallel arrangements are somewhat less often used—the combination of these two is very frequently used.

More than likely, you can conceive of the general structure of such a series-parallel arrangement. . . . The name itself is its description. . . . *Essentially it is an arrangement wherein the total current flows through one or more elements and then divides and flows through a number of branches of some other elements.* A circuit which fulfills these conditions and is typical of a series-parallel arrangement, is shown in Fig. 55. The resistor R1 is in series with the parallel circuit consisting of the two resistors R2 and R3. From the angle of the current flow, the total current in the circuit flows through R1 and then divides through the R2 and R3 branches of the parallel combination.

What determines the total current in the circuit? . . . If R1 alone were in the system, then it would be the determining influence. . . . Since it is one of the elements in the circuit, it



contributes a certain amount of the total opposition. . . . The remainder of the opposition to the flow of current is furnished by the combined action of R2 and R3 in parallel. . . .

In other words, the total resistance  $R_t$  in this circuit is

$$R_t = R_1 + (R_2 \text{ and } R_3 \text{ in parallel})$$

In order to be able to establish the sum of R1 and (R2 in parallel with R3), we must first solve for the joint resistance of the com-

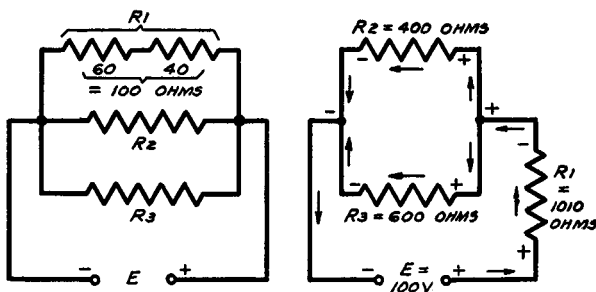

**Fig. 54, left, Fig. 55.** If two or more resistors in series are in one leg of a parallel circuit, see Fig. 54, their total resistance (found by adding the two or more values) is used in finding the resistance of the parallel circuit. The total resistance of the series-parallel circuit, Fig. 55, is found by solving for the combined resistance of the parallel resistors, R2 and R3, and adding this to the value of R1.

ination. According to the statements made in connection with parallel circuits, the simplest method of determining the joint resistance of two such units in parallel is by the product and sum method, viz:

$$R = \frac{400 \times 600}{400 + 600} = \frac{240,000}{1,000} = 240 \text{ ohms}$$

is the joint resistance of R2 and R3 in parallel. With R1 equal to 1,010 ohms, the total resistance is

$$R_t = 1,010 + 240 = 1,250 \text{ ohms}$$

The total current in the circuit, according to Ohm's Law, is

$$I = \frac{E}{R} = \frac{100}{1,250} = .08 \text{ ampere}$$

If we consider the parallel combination of R2 and R3 as a single unit, the circuit arrangement shown in Fig. 55 then becomes a simple series circuit wherein .08 ampere of current flows. In line with what happens in series circuits, the applied voltage is then distributed as a voltage drop across R1 and across the parallel combination of R2 and R3. The drop across R1 is

$$E = IR = .08 \times 1,010 = 80.8 \text{ volts}$$

and the drop across the parallel combination is

$$E = IR = .08 \times 240 = 19.2 \text{ volts}$$

The sum of these two voltage drops equals the applied voltage. As far as the parallel circuit is concerned, the drop of 19.2 volts is present across both resistors.

As to the current flow, .08 ampere flows through R1 and it divides between the two branches of the R2-R3 parallel combination. It is significant at this time to mention that this total current of .08 ampere *divides* between the two branches. Do not make the mistake of believing that this amount of current flows through each branch.

What is the current flow through each of the parallel branches? . . . Since a voltage exists across the terminals of this branch, it is logical that the amount of current, which will flow through each branch, is determined by the resistance of the branch. In other words, the current in the R1 branch, according to Ohm's Law, is

$$I_{R_1} = \frac{E}{R} = \frac{19.2}{400} = .048 \text{ ampere}$$

and the current through the R2 branch is, according to Ohm's Law,

$$I_{R_2} = \frac{E}{R} = \frac{19.2}{600} = .032 \text{ ampere}$$

and since the sum of the currents through the branches of a parallel circuit is equal to the total current in the circuit,

$$I_t = I_{R_1} + I_{R_2} = .048 + .032 = .08 \text{ ampere}$$

*As is evident, the higher the resistance of the branch, the less the current and, inversely, the lower the resistance of the branch, the greater the current.* This item is an important consideration as you will see in practice. In making this statement, we are more concerned with the distribution of the current between the two branches with respect to the relative resistances rather than with the conclusion normally to be derived from the application of Ohm's Law, wherein the current is found to be inversely proportional to the resistance.

We would like to add here that the method employed to establish a total current in the circuit and the division of this total current between the branches of the parallel system shown in Fig. 55, is applicable in its entirety to series-parallel combinations, consisting of more than one series resistor and to parallel combinations, which employ more than two branches.

## Chapter V

### PRACTICAL APPLICATIONS OF PARALLEL AND SERIES-PARALLEL CIRCUITS

In order to present the practical applications of parallel and series-parallel circuits, we deem it best to segregate these two arrangements and to consider first the normal application of parallel arrangements. While it is true that in the majority of cases the practical application involves both series and parallel arrangements, some few instances exist, where the parallel circuits, without any relation to a series arrangement, are found. One of these is the filament or heater system in a receiver or an amplifier.

In view of the fact that the voltage is the same across the terminals of all of the branches of a parallel circuit, it is essential that when devices are connected in parallel, all must be rated at the same voltage. In other words, the filaments or heaters, shown in Fig. 56, connected in parallel, are operated at the same voltage. The current rating, that is, the resistance of the filaments or heaters, is of no importance just so long as they are all rated at uniform values of voltage. When filaments or heaters are connected in parallel, the current consumption of the various heaters or filaments is added, so as to arrive at the final figure representative of the total current flow in the system.

One of the most commonplace applications of the simple parallel circuit is the arrangement of a value of resistance which is not available as a single unit. For example, in Fig. 57 a resistor  $R$  of 1,000,000 ohms is in the plate circuit of a tube and the circuit requires that this resistor be replaced by a 300,000-ohm unit. Such a unit is not available, but several other values are on hand. What value of resistance can be connected in shunt with the 1,000,000-ohm resistor  $R$ , so that the resultant resistance of the combination is 300,000 ohms? In other words, what is the value of  $R_x$ ? . . . The following relation applies to this problem:

$$R \text{ shunt} = \frac{\text{desired resistance} \times \text{initial resistance}}{\text{initial resistance} - \text{desired resistance}}$$

which in this case is

$$\frac{300,000 \times 1,000,000}{1,000,000 - 300,000} = \frac{300,000,000,000}{700,000} = 428,571 \text{ ohms}$$

which in round numbers is 400,000 ohms. Suppose that we take another example which employs smaller figures. We have an

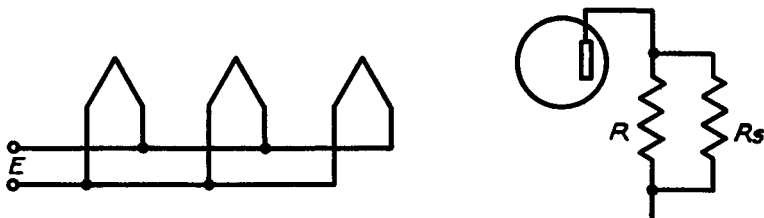

*Fig. 56, left, Fig. 57. When devices are connected in parallel, the voltage is the same across each one and the total current consumed is found by adding the current used by each. The method of finding the value of a resistor  $R_s$ , Fig. 57, to bring the total resistance of a parallel circuit to a certain value, is explained in the accompanying text.*

initial resistance  $R$  of 10,000 ohms. We desire to shunt some other resistance across  $R$ , so that the combined resistance  $R_1$  will be 8,000 ohms. What resistance  $R_s$  must be shunted across  $R$  so as to produce  $R_1$ ? According to the relation previously given,

$$R_s = \frac{R \times R_1}{R - R_1} = \frac{10,000 \times 8,000}{10,000 - 8,000} = \frac{80,000,000}{2,000} = 40,000 \text{ ohms}$$

In each and every case, the value  $R_s$ , as determined in connection with the foregoing two problems, must be capable of carrying the current present in the circuit.

You will frequently find two resistances in parallel in order to provide for proper power dissipation, because a single unit of equivalent resistance and capable of dissipating the proper amount of power, is not available. For example, suppose that the circuit requirements call for a resistance of 200 ohms ca-

pable of passing 2 amperes. According to the equation for power, power =  $I^2R = 4 \times 200 = 800$  watts. By dividing the current between the two resistances, R1 and R2, shown in Fig. 58, it is possible to develop a resultant resistance of 200 ohms and to divide the current so that each of these resistances dissipates a certain portion of the required 800 watts. Naturally, the simplest arrangement is to use two equal values of resistance, each of which will carry 1 ampere of current. The value of these resistances can be determined by the application of Ohm's Law.

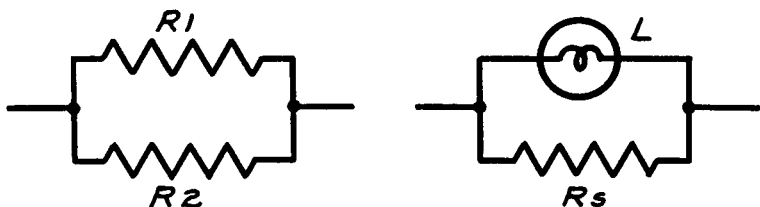

*Fig. 58, left, Fig. 59. Often two parallel resistors, R1 and R2, can be used to dissipate a large amount of power when a resistor of larger wattage rating and a resistance equal to the parallel value of the two, is unavailable. In Fig. 59, Rs is shunted across the lamp to prevent its burnout.*

We stated that the required resistance is 200 ohms and the current flow is 2 amperes, which means that 400 volts is present across the resistors. On this basis, the value of R1, in order that it pass 1 ampere, is

$$R = \frac{E}{I} = \frac{400}{1} = 400 \text{ ohms,}$$

and the value of R2 is

$$R = \frac{E}{I} = \frac{400}{1} = 400 \text{ ohms}$$

The combined value of these two resistances, according to the product and sum equation, is

$$\frac{400 \times 400}{400 + 400} = 200 \text{ ohms}$$

The power across R1 then is  $I^2R = 1 \times 400 = 400$  watts, and the power R2 is  $I^2R = 1 \times 400 = 400$  watts. Thus we divide the current between the two circuits and also the power in the circuit.

Another example of division of current for use in the parallel system is that given in Fig. 59. L is a pilot light operated at 6 volts and .2 ampere. It is used in a heater circuit wherein .3 ampere flows. What value of shunt resistance must be connected across L so that .2 ampere will flow through L and .1 ampere will flow through the shunt resistance  $R_s$ , thereby permitting the use of the pilot light in the system? According to Ohm's Law, the resistance of the pilot light is

$$R = \frac{E}{I} = \frac{6}{.2} = 30 \text{ ohms}$$

A very simple method of determining the value of  $R_s$  is to consider the division of the currents. The lamp passes twice as much current as the shunt. Consequently, according to Ohm's Law, the value of the resistance  $R_s$  must be twice as great as the resistance of the lamp L in order that it pass half as much current, when the voltage is the same across both units. Since the lamp L passes .2 ampere and has a resistance of 30 ohms, and the shunt resistance  $R_s$  must pass half as much current, it stands to reason that its resistance must be twice as great, consequently the value of  $R_s$  is 60 ohms. This is checked when you apply Ohm's Law for resistance, namely,

$$R = \frac{E}{I} = \frac{6}{.1} = 60 \text{ ohms}$$

An example typical of series-parallel circuits is shown in Fig. 60, wherein filament voltage is fed to three filaments, F1, F2 and F3, connected in

*Fig. 60. The three filaments, F1, F2, and F3, are connected in series and the filaments F4 and F5 are in parallel. The first three are in parallel with R1 and the second pair. The proper filament voltage is obtained by utilizing the IR drops of R, L, and R1.*

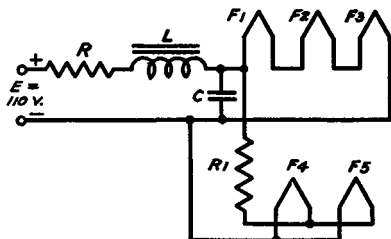

series, and two filaments, F4 and F5, connected in parallel. The filament voltage is secured from the power supply through two voltage-dropping

resistors,  $R$  and  $R_L$ , and a filter choke  $L$ . The condenser  $C$  is shown, but does not enter into the discussion. The electrical equivalent of Fig. 60 is shown in Fig. 61, wherein the choke  $L$  and the five filaments are replaced by resistors. For a proper analysis of voltage distribution in such a circuit, it is best to separate the system into its two component parts, that is, the series system and the parallel system. The junction points between the two systems are indicated by  $X$  and  $Y$ .

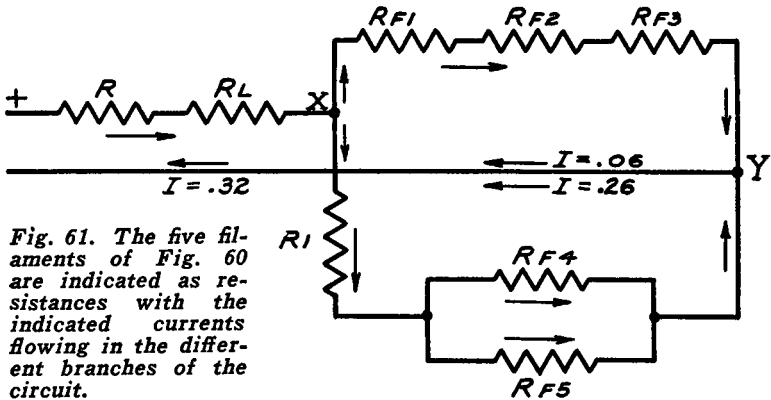

Fig. 61. The five filaments of Fig. 60 are indicated as resistances with the indicated currents flowing in the different branches of the circuit.

The filament ratings of  $F_1$ ,  $F_2$  and  $F_3$  are 2 volts at .06 ampere for each tube, and for  $F_4$  and  $F_5$  they are 2 volts at .13 ampere for each tube. We note that the three filaments,  $R_{F_1}$ ,  $R_{F_2}$  and  $R_{F_3}$ , are connected in series, which means that the current is .06 ampere through the circuit; whereas the voltage across the series combination is the sum of the three voltage drops, namely 6 volts. In accordance with these figures, the required voltage across  $X$  and  $Y$ , in Fig. 61 is 6 volts, and since the resistance of  $L$  is 80 ohms, we must establish the value of  $R$ , so that the correct voltage is available across points  $X$  and  $Y$ .

If you now examine the circuit in Fig. 61, you will note the presence of the parallel circuit connected across  $X$  and  $Y$ , which means that the current flowing through the resistances  $R$  and  $R_L$  is not only the current of the three filaments connected in series, but also the current of the two filaments,  $F_4$  and  $F_5$ , which are connected in parallel. In other words, when solving for the value of  $R$ , it is essential to realize that the drop across this resistance takes place at the sum of the currents in the series circuit and in the parallel circuit. According to the specifications of the filaments  $F_4$  and  $F_5$ , the total current consumption is .26 ampere and the voltage across the



circuit is 2 volts. This means that the current flowing through R and  $R_L$  is .32 ampere. Of this amount of current, .06 ampere, or 60 milliamperes, flows through  $R_{F1}$ ,  $R_{F2}$  and  $R_{F3}$ , whereas 26 ampere, or 260 milliamperes, flows through R1 and then this total of 260 milliamperes divides between  $R_{F4}$  and  $R_{F5}$ .

Now, we know that we require 6 volts across X and Y, consequently we must drop the line voltage of 110 volts to the required 6 volts, which means a difference of 104 volts. Solving for  $R_T$ , we use the conventional Ohm's Law for resistance wherein

$$R_T = \frac{E}{I} = \frac{104}{.32} = 325 \text{ ohms}$$

We stated that the d-c. resistance of L was 80 ohms, so that the value of R is the difference between the total resistance required and the d-c. resistance of L, namely  $325 - 80 = 245$  ohms.

The next problem is to establish the value of R1, whereby the 6 volts available across X and Y is reduced to 2 volts required for the two parallel filaments. In other words, we must drop 4 volts at the current consumption of the parallel circuit, namely .26 ampere. To solve for R1, we use Ohm's Law for resistance, wherein

$$R1 = \frac{E}{I} = \frac{4}{.26} = 15.4 \text{ ohms}$$

As far as direction of current flow is concerned and the direction of the voltage drops, these are indicated by the arrows in Fig. 61.

Another example of voltage distribution is shown in Fig. 62, wherein is illustrated a screen grid tube system such as is used in very many receivers produced during 1932 to 1935.  $R_C$  is the cathode bias resistor, R1 and R2 constitute a voltage divider system, whereby a certain amount of bleeder current is fed to the cathode, and the proper voltage is applied to the screen grid of the tube. R3 is a voltage-dropping resistor and L is a winding in the plate circuit. The electrical wiring diagram of this system is as shown in Fig. 63, wherein  $R_C$  is the cathode bias resistor, which, for the purposes of this problem, is fixed at a value of 800 ohms. . . .  $R_P$  is the plate resistance,  $R_L$  is the d-c. resistance of the winding L, and R3 is the voltage-dropping resistor in the plate circuit.  $R_{sc}$  is the internal screen-to-cathode resistance, and R1 and R2 comprise the voltage divider system for the screen grid. The control grid and the winding L1, shown in Fig. 62, are not repeated in Fig. 63, because there is no current flow in the circuit

and it is sufficient to state that a certain bias voltage will be applied to the control grid of the tube.

We know certain standard specifications for our typical circuit. We know that the plate voltage required is 160 volts, which means that point A is 160 volts plus with respect to the negative end of the voltage supply system E. We further know that at this voltage the plate current is 5 milliamperes, or  $I_P = .005$  ampere. We further know that the screen circuit requires 90 volts, which means that point B is 90 volts plus with respect to the minus side of the voltage supply source, and that the screen

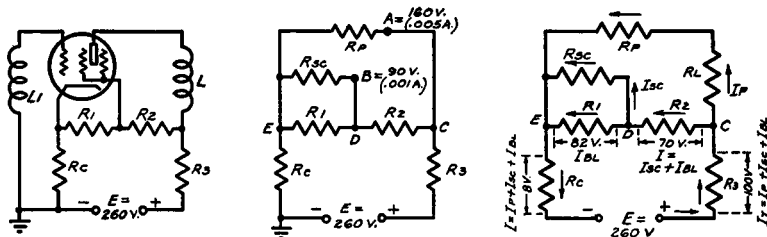

**Figs. 62, 63, 64, left to right. A typical voltage distribution network to a screen-grid tube is shown in Fig. 62. The plate resistance and screen-to-cathode resistance are shown in Figs. 63 and 64 as resistors. The direction of the current flow is indicated in the latter by arrows, together with the voltages across the several resistors.**

current is 1 milliampere, or  $I_{Sc} = .001$  ampere. According to Fig. 62, the d-c. resistance of the winding L is equal to 50 ohms, so that  $R_L = 50$  ohms. We further know that the control grid bias is minus 8 volts.

If we trace the path of the several currents flowing in the circuit, we develop the arrangement shown in Fig. 64. The total current  $I_t$  flows through resistor  $R_3$  and the plate current  $I_P$  flows through  $R_L$  and  $R_P$ . It also flows through the bias resistor  $R_c$ . The bleeder current flows through  $R_2$ , through  $R_1$  and through  $R_c$ .

Let us solve for the values of some of these units in order to fulfill the various conditions which we have named. Knowing that the voltage at the plate of the tube must be 160 volts, the current is 5 milliamperes, and the available voltage E is 260 volts, we must establish the value of resistance required in the plate circuit to drop the available voltage to the required 160 volts. This means that we must drop  $260 - 160 = 100$  volts at .005 ampere. **However, we also find that the current, which flows through  $R_3$ , is not only the plate current of 5 milliamperes, but also the screen current and the bleeder current.** Obviously the grid

bias voltage developed across the cathode resistor is not entirely that due to the plate current, because if  $R_C = 800$  ohms and the plate current is 5 milliamperes, the voltage drop across  $R_C$ , which is due to the plate current, is only 4 volts,—and we require 8 volts! It therefore stands to reason that the grid bias developed across resistor  $R_C$  is that due to the *plate current plus other currents*, because in accordance with Ohm's Law, 10 milliamperes of current is required through  $R_C$  in order to develop the 8-volt bias.

Now, since the total current in the circuit flows through  $R_C$  as well as  $R_3$ , and we know the required current through  $R_C$ , we know that when we establish the value of  $R_3$  in order to drop the voltage at the plate to the required 160 volts, it must be at 10 milliamperes. At this time it will be valuable to select point C in Fig. 64 as being a reference point with respect to voltage, because it is at that point where the current divides into the various branches. We know the plate current, which means the current flowing through  $R_L$ , hence we can establish the voltage drop existing across  $R_L$  and then develop the drop required across  $R_3$  so that we can properly distribute the various voltages.

The drop across  $R_L$  is, according to Ohm's Law,  $E = I \times R$  is equal to  $.005 \times 50$  or .25 volt, which is entirely negligible as far as our computations are concerned.

In view of what has been said, points A and C are substantially at the same voltage, which means that point C is approximately 160 volts positive with respect to the negative side of the voltage supply source and the value of  $R_3$  must be such as to drop 100 volts at 10 milliamperes. Therefore,  $R_3$  is, according to Ohm's Law,

$$R_3 = \frac{E}{I} = \frac{100}{.01} = 10,000 \text{ ohms}$$

We know that 5 milliamperes of current flow through the plate circuit, which means that 5 milliamperes of current remain to flow through  $R_2$  and divide between the screen grid resistance  $R_{SC}$  and  $R_1$ . Knowing that the screen grid requires 90 volts, and since the voltage at point C is 160 volts—we know that  $R_2$  must drop 70 volts, so that 90 volts will be available at the screen grid of the tube. We also know that 5 milliamperes of current flow through  $R_2$ —which means that 70 volts must be dropped at 5 milliamperes. That makes the value of  $R_2$  equal to

$$R_2 = \frac{E}{I} = \frac{70}{.005} = 14,000 \text{ ohms}$$

We said that 1 milliamperes of current flowed through the screen grid circuit, which means that 4 milliamperes flow through R1. Now we know that the screen grid is 90 volts positive with respect to the negative side of the voltage supply E. According to the manner in which R1 is located in the circuit, point D is at the same potential as the screen grid of the tube. Point E, on the other hand, is 8 volts positive with respect to the negative side of the voltage supply source, which means that R1 must drop 82 volts at 4 milliamperes. Therefore

$$R_1 = \frac{E}{I} = \frac{82}{.004} = 20,500 \text{ ohms}$$

As far as the cathode resistor  $R_C$  is concerned, the 10 milliamperes of current flow through the unit and consist of  $I_P = 5$  milliamperes— $I_{SC}$  of 1 milliamperes and the bleeder current of 4 milliamperes.

As far as the power rating of R1, R2 and R3 is concerned, the following figures apply: The power to be dissipated by resistor R1 is

$$P_{R_1} = I^2R = (.004)^2 \times 20,500 = .328 \text{ watt}$$

in round numbers, .5 watt, and

$$P_{R_2} = I^2R = (.005)^2 \times 14,000 = .35 \text{ watt}$$

in round numbers, .5 watt, and

$$P_{R_3} = I^2R = (.01)^2 \times 10,000 = 1 \text{ watt}$$

### Voltage Dividers

We have made a number of references to voltage dividers and in practically every instance the subject was mentioned in connection with a number of series resistances, wherein it was understood the current was the same throughout the system and the division occurred in accordance with the respective values of the resistances.

What was said should not be construed as meaning that the current is always the same throughout each element of a voltage divider. . . . As a matter of fact, such types of dividers, with the exception of the C bias arrangement already mentioned, are not very commonplace in actual practice. The time, therefore, is ripe for a discussion of the practical types of dividers used in connection with power supply devices.

To start with, the operation of these devices is founded upon the basic principles outlined in connection with the ordinary division of voltage by means of resistances. . . . In each and every case, the division of voltage is the consequence of the presence of current flow through a resistance. . . . The marked difference between the types of voltage dividers used for the division of operating potentials, such as plate and screen voltages, and the division of potentials in an ordinary series circuit, is that in the former case the current is not the same throughout the circuit of the voltage divider.

Take as an example the three resistance series network  $R_1$ ,  $R_2$  and  $R_3$  shown in Fig. 65. These three resistors, connected across a filter system of a rectifier, constitute a simple series

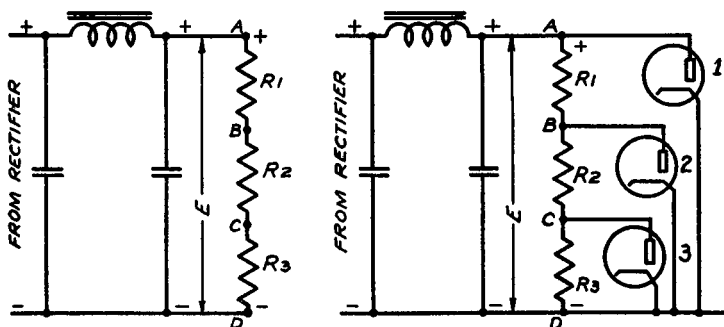

*Fig. 65, left, Fig. 66. The three resistors,  $R_1$ ,  $R_2$ , and  $R_3$ , form a voltage divider, see Fig. 65, and three different voltages are taken off at the points A, B, and C. See the accompanying text for an explanation of the different currents that flow in the three resistors.*

circuit and as such, the current due to the voltage impressed from the filter of the rectifier system, is the same throughout the system and this conforms with the basic facts. . . . The drop across the respective resistances is a function of the total current and the respective values of resistance. . . . However, if this network without any changes is used to divide the voltage  $E$ , available

from the filter system, to a number of different circuits—each of which requires current, the current is no longer the same through the three resistors and the drop across the individual resistors depends upon the current and the resistance. For example, suppose, that we connect three vacuum tubes to this network and arrange that the voltage available at the terminals A, B and C constitute the plate voltage of these three tubes. . . . Just what we mean is illustrated in Fig. 66. Point A along the divider supplies the plate voltage for tube 1; point B along the divider supplies the plate voltage for tube 2, and point C supplies the

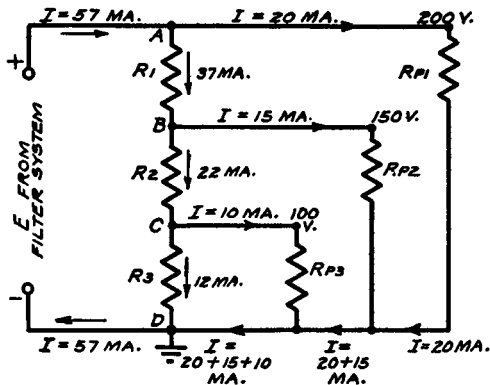

Fig. 67. The plate resistances of the three tubes of Fig. 66 are here represented as pure resistances and the different currents flowing in each tap from the voltage divider are indicated. Note that the only current flowing through  $R_3$  is the bleeder current of 12 ma.

plate voltage for tube 3. The electrical equivalent of this circuit is shown in Fig. 67, wherein the d-c. plate-cathode resistance of each tube is identified as  $R_P$ .

Suppose for the sake of illustration that the rated plate voltage of tube 1 is 200 volts and the plate current is 20 milliamperes. . . . The rated plate voltage of tube 2 is 150 volts and the plate current is 15 milliamperes and the rated plate voltage of tube 3 is 100 volts with a plate current of 10 milliamperes. (These plate voltage and plate current values are not typical of any particular type of tube and are given simply for the purpose of illustration.) The various voltages and the various currents are identified in Fig. 67.

Let us now analyze the path of these currents. . . . What currents flow in this system? . . . In the first place, the series network of  $R_1$ ,  $R_2$ , and

R3 constitutes a complete path across the filter network, consequently, the voltage E will cause the flow of some value of current through R1, R2 and R3—irrespective of what happens in connection with tubes 1, 2 and 3. . . . In other words, the three tubes can be removed from their sockets and some value of current, small or great—depending upon the total resistance of the three resistances R1, R2 and R3—will flow through the divider. . . . This current is the bleeder current, usually predetermined in value when the voltage divider is designed, but whatever value it may be, the fact remains that some value of bleeder current flows through R1, R2 and R3. . . . So much for that and it should be remembered for future reference.

Now for the currents flowing in the various plate circuits. . . . The plate current of tube 1 flows out at tap A and finds its way back into the power supply system via the d-c. plate-cathode resistance of tube 1 and the junction between the cathode and point D on the divider. We have 20 milliamperes of current flowing out of the power supply and not passing through the divider.

Now, the plate of tube 2 is operated at a lower voltage than the plate of tube 1, so that a drop in voltage is required. . . . This is the function of R1. According to the figures shown in Fig. 67, a 50-volt drop takes place across R1. . . . However, this drop does not take place as the consequence of the relative values of R1, R2 and R3. . . . Instead it is a function of the amount of current required by tube 2 PLUS other currents. . . . In the first place, the current through R1 is not only the plate current of tube 2, which is 15 milliamperes; in addition to this amount of current, there is flowing through R1, the 10 milliamperes required by the plate circuit of tube 3. . . . In addition to the 10 milliamperes required by the plate circuit of tube 3, the bleeder current also flows through R1. . . .

If we arbitrarily set the bleeder current at 12 milliamperes, the total current flowing through R1 is the 15 milliamperes of tube 2, the 10 milliamperes required for tube 3, and the 12 milliamperes bleeder current making a total of  $15 + 10 + 12 = 37$  milliamperes, AND THE VOLTAGE DROP ACROSS R1 IS  $I \times R$ , where I is the aforementioned 37 milliamperes, and R is the ohmic value of R1.

Now for tube 3. The plate circuit of this tube requires 100 volts at 10 milliamperes, which means that this plate is operated at a lower voltage than the plate of tube 2. . . . Another voltage drop is required and this is the function performed by R2. . . . A drop of 50 volts takes place across R2. . . . At what value of current? . . . How much current is flowing through R2? . . .

We know that the 10 milliamperes required for the plate circuit of tube 3 flows through R2, because of the location of point C and the direction of current flow. . . . Since the bleeder current of 12 milliamperes flows through all of the resistors, it stands to reason that it flows through R2. . . . What about the 15 milliamperes required for the plate circuit of tube 2? This current flows through R1, but it does not flow through R2, because it passes out through the feeder lead joining point B and the plate of tube 2. . . . Hence, resistor R2, carries 22 milliamperes of current,—and the drop of 50 volts, which is necessary so that the plate of tube 3 will receive the required 100 volts, is secured at a current of 22 milliamperes and NOT at the 10-milliamperere current required by tube 3.

What about R3? . . . The 12 milliamperes of bleeder current flow through R3 and the voltage drop across this unit is that required to drop the 100 volts difference existing between points C and D.

How about the current? . . . If we review the currents flowing in the various branches, we have 20 milliamperes to the plate circuit of tube 3 and 12 milliamperes bleeder current, making a total of  $20 + 15 + 10 + 12 = 57$  milliamperes,—which is the total current flowing out of the filter towards point A, or out of point A in all directions and is the amount of current flowing into point D and then back to the filter system.

Perhaps the circuit of Fig. 68 will help make even clearer the distribution of these currents. This schematic is the same as that shown in Fig. 67, except that the location of the respective resistances has been rearranged so as to show the division of the currents at points A, B and C more clearly. . . . All of the current flows out at point A and flows in at point D. . . . The potential of the points A, B, C and D in Fig. 68 is the same as that for A, B, C and D in Fig. 67.

Having determined the several currents and voltage drops, it is a simple application of Ohm's Law to find the values of R1, R2 and R3:

$$R1 = \frac{50 \text{ volts}}{.037 \text{ ampere}} = 1350 \text{ ohms}$$

$$R2 = \frac{50 \text{ volts}}{.022 \text{ ampere}} = 2270 \text{ ohms}$$



$$R_3 = \frac{100 \text{ volts}}{.012 \text{ ampere}} = 8333 \text{ ohms}$$

The determination of the power capacity of these resistors follows along the same lines previously discussed:

$$P = IE$$

For R1,

$$P = .037 \text{ ampere} \times 50 \text{ volts} = 1.85 \text{ watts}$$

For R2,

$$P = .022 \text{ ampere} \times 50 \text{ volts} = 1.10 \text{ watts}$$

For R3,

$$P = .012 \text{ ampere} \times 100 \text{ volts} = 1.2 \text{ watts}$$

In practice, each of the resistors in this voltage divider would in general have a commercial rating of 2 watts.

It might be well to close this volume with a brief example of

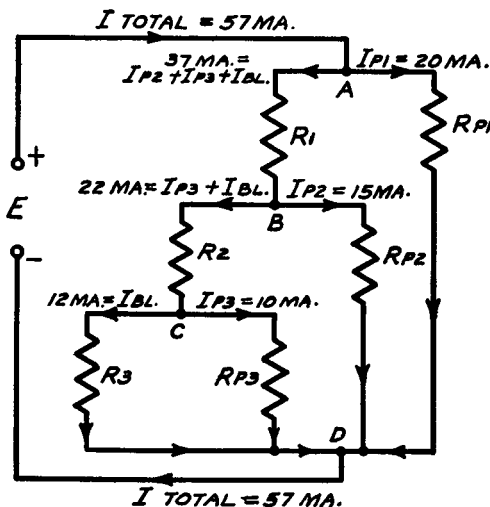

Fig. 68. This schematic diagram is similar to that shown in Fig. 67, except that the resistors have been rearranged to illustrate more clearly the division of the various currents flowing from points A, B, and C.

the relations existing in a modern power supply and voltage divider system, in which the output tube bias voltage is developed across the speaker field winding located in the negative leg of the power supply filter system.

In general, circuits of this type follow along the lines indicated in Fig. 69. This voltage divider system makes available four different voltages: the highest voltage with respect to ground being at point A, the next highest at point B, the next highest at point C, and the lowest voltage at point D. In addition to the above voltages, which are all (+) with respect to ground, there is a voltage drop across the speaker field coil. The direction of the current through the speaker field is such as to make point F (—) with respect to the ground, point E. An additional voltage divider across the speaker field serves to provide the correct value of bias for the power tube and for other purposes, if so desired. It should be noted that no current is drawn from the tap C—on the bias voltage divider and that the resistance of the voltage divider is high in comparison with that of the field resistance, so that the current through the bias voltage divider is negligible in comparison with the current through the field.

We want to comment first on the meaning of the resistances designated as R2, R3, R4 and R5, each of which is enclosed with a circle. These represent the load across the several taps of the voltage divider due to the tubes which are connected across the point in question. **While only one symbol is used to designate the load across each point on the voltage divider, it should be understood that this represents any number of tubes and that the current in question represents the combined plate current of all the tubes, which are fed from any one point on the voltage divider.** For example, R4 represents the combined resistance of all the r-f. and i-f. tubes in the receiver, which operate at the same plate voltage of say 250 volts. In like manner I4 represents the combined plate current of all these tubes. As a further example, point D may be connected to the screen of the resistance-coupled pentode used in the a-f. amplifier of the receiver and I2 will consequently represent the screen current of this tube. If, in addition the screen of the first detector were connected to point D, then I2 would represent the combined currents and not just a single current. Similar relations hold for the remaining currents.

Let us now analyze the distribution of currents. Referring to Fig. 69, and beginning at the output of the rectifier, we note that a high voltage is available across points A and F, which consti-

tutes the input to the filter and voltage divider system. At point A, the first division of the current takes place. If the current taken from point A by the power tube or tubes is denoted by  $I_5$ , then you will note that this current leaves point A and passes through the power tube or tubes, and returns to ground, as is indicated in the diagram. The remainder of the current which, for convenience, is denoted as  $I_1, I_2, I_3$  and  $I_4$ , passes through the filter choke, which is designated  $L_1$ . At the next junction, which is B, the current again divides. This time the current, which is taken from the voltage tap at B by the tubes connected to this

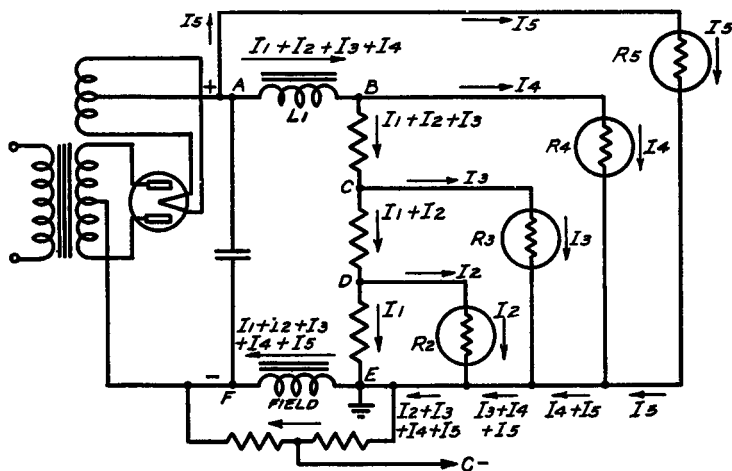

**Fig. 69.** The various currents flowing in each branch of the power pack and the several taps from the voltage divider, are indicated together with the direction of flow.

point, is denoted by  $I_4$ . The current returns through the respective tube circuits to ground. The remainder of the total current, which originally left point A, travels through the first resistor of the voltage divider and arrives at the junction C. The amount of this current by simple subtraction is equal to  $I_1 + I_2 + I_3$ . At the junction C, this current further divides, so that the amount of current taken by the tubes at this voltage is  $I_3$  and the remainder, which is  $I_1 + I_2$ , passes through the voltage divider

resistor down to the next junction at point D. Here a further division of the current takes place. Current  $I_2$  flows to the tubes connected to point D, and the remaining current  $I_1$  flows through the last resistor of the voltage divider to the ground junction of the network, which is at point E.

However, the current flow does not cease at this point, since there must be a complete circuit for the flow of current. Consequently, the current  $I_1$  which flows through the last leg of the voltage divider, must return to the rectifier through the field coil. Furthermore, the currents distributed to the various tubes must also return to the negative leg of the rectifier output through the speaker field. The net result is that the sum total of all the currents which leave point A, must flow through the field coil and in terms of the symbols used here, the current through the field coil is  $I_1 + I_2 + I_3 + I_4 + I_5$ . The drop across the field coil will then be this total current multiplied by the field coil resistance.

In view of what already has been said about the computation of voltages we need hardly go into detail as to the quantitative relationships in this circuit. However, we might point out that when once the various currents are determined, as in Fig. 69, then the computation of the various resistances in the voltage divider is simply a matter of dividing the desired voltage drop across the resistor in question, by the total of the current which flows through that resistor. . . . So much for that.

We hope that the repeated examples of Ohm's Law, as given in this volume, will prove of definite aid in the comprehension of the mode of d-c. voltage distribution in receivers and the measurement of such voltages and currents.