

on
RESONANCE
and
ALIGNMENT

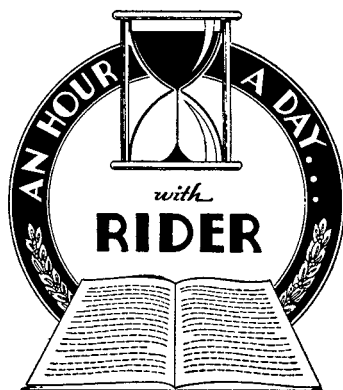

ON
RESONANCE
AND
ALIGNMENT

Published by

JOHN F. RIDER, Publisher

1440 BROADWAY

NEW YORK CITY

Copyright 1936, by
JOHN F. RIDER

*All rights reserved, including that of translation
into the Scandinavian and other
foreign languages*

Printed in the United States of America

TABLE OF CONTENTS

- CHAPTER I. GENERAL REVIEW OF TUNED CIRCUITS.—1.** Reactance and Impedance—2. Inductive Reactance—2. Capacitive Reactance—4. Series Resonance—6. Tuning or Trimming—9. Applications of Series Resonant Circuit—10. Parallel Tuned Circuit—11. Effect of Resistance on Series Tuned Circuit—17. Effect of Resistance on Parallel Tuned Circuit—20. Shunt Resistance—22. Coupling and Resonance Curves—23. The Double Tuned Transformer—26. Selectivity Requirements—31. Variable Selectivity Circuits—33.
- CHAPTER II. ALIGNMENT PROCEDURE.—39.** Need for Alignment—40. Trimmer Adjustments—42. Use of the Tuning Wand—43. Regeneration—44. AVC Adjustment during Alignment—44. Output Indicators in Audio System—45. Output Indicators Based upon AVC Action—47.
- CHAPTER III. ALIGNMENT AND NEUTRALIZATION OF TRF RECEIVERS.—49.** Synchronizing Variable Condensers—52. Neutralization of TRF Receivers—52. Neutralizing Procedure—53.
- CHAPTER IV. THE ALIGNMENT OF SUPERHETERODYNE RECEIVERS.—55.** General I-f. Amplifier Alignment—57. Aligning Atwater Kent Receivers—58. Balancing Unit for General Use—59. Aligning Overcoupled I-f. Transformers with Output Meter—60. Neutralization of I-f. Amplifiers—61. Regenerative I-f. Amplifiers—61. Staggering—62. Dual Band Receivers with Single Oscillator Range—65.
- CHAPTER V. OSCILLATOR ALIGNMENT.—66.** Oscillator Tracking—67.
- CHAPTER VI. R-F. AND DETECTOR ALIGNMENT.—70.** Dummy Antenna—70. R-f. and First Detector Alignment—70. Low-Frequency Oscillator Alignment—72. Rocking Necessary for High-Frequency Detector Alignment—73. Insufficient Attenuation at Higher Frequencies—73. I-f. Wave Trap Adjustment—74. Image Suppression Circuits—75. Double Conversion Systems—77. Converter Alignment—79. Beat Oscillator Alignment for C-W. Reception—80. Adjusting 10-Kc. Audio Filters—80. Determining Unknown I-f. Peaks—81. Use of Signal Generator Harmonics—82. Visual Alignment—84. Visual Alignment at 600 Kc.—88. Frequency Range of Visual Alignment—91.

Chapter I

GENERAL REVIEW OF TUNED CIRCUITS

AT FIRST thought it may seem inappropriate to begin a discussion of alignment and its problems by a consideration of the tuned circuit and the elements of which it is composed. However, when we take into account the fact that the tuned circuit is the basic unit encountered in all alignment problems, it is only natural to expect that a knowledge of the operation of a tuned circuit will be of tremendous value in simplifying the problems encountered during the alignment process. It is of extreme importance that the man called upon to align a receiver be as familiar with what is actually happening, speaking from the technical viewpoint, when a circuit is trimmed, as he is with the ultimate result with respect to operation of the receiver unit. Admittedly, alignment operations have been carried on for a long time—but in altogether too many cases these operations consisted of nothing more than a series of arbitrary or mechanical steps.

Basically, all alignment operations are alike, yet all of us who have had experience in this type of work realize that certain differences exist purely as a result of circuit variations introduced by the men responsible for the design of the receiver. With nothing but a mechanical knowledge of the operations of a radio receiver, the men called upon to align such receivers consider each of these various systems as a separate and different problem. A general review of resonance phenomena and the functions of the elements which comprise the tuned circuits, cannot help but prove of value in attaining proficiency in aligning. It is for this reason that the first section of this book is devoted to a general treatment of the tuned circuit.

It is our intention, with respect to the general treatment of the tuned circuit, to omit the mathematical details. In the event that you are interested in the complete technical exposition of the tuned circuit with its ramifications and in the practical mathematics relating thereto, we suggest that you secure the companion volume "An Hour A Day With Rider On Alternating Currents In Radio Receivers."

Reactance and Impedance

When a direct current is caused to flow through a circuit, that current meets no opposition or hindrance other than the direct-current resistance of the circuit. If, however, an alternating current is caused to flow through the circuit, the opposition to the flow of that current depends upon several factors. One of these is the *resistance* of the circuit; another is the *reactance* of the circuit, usually expressed in ohms. The total hindrance encompassing the resistance and the reactance, is known as the *impedance*, which, likewise, is expressed in ohms.

Inductive Reactance

By inductive reactance is meant the opposition to the flow of alternating current presented by an inductance. An inductance, sometimes referred to as an inductor, may be in any one of a number of forms. Such units as r-f. chokes, filter chokes, plate chokes, the windings in r-f., i-f., a-f., and power transformers are inductances. In fact, all coils are inductances, with the exception of such windings as are especially arranged to be free of inductive properties. Lest some misconception exist, the term inductance, as designating the physical unit, has become a commonplace expression, hence is used throughout this volume.

Inductive reactance depends primarily upon the frequency of the applied voltage and the inductance value of the unit. Whenever inductive reactance is mentioned, it is customary to mention also the frequency, at which the measurement was made viz; a choke has a reactance of 1000 ohms at 60 cycles. The manner in which inductive reactance varies with frequency is illustrated in Fig. 1, wherein inductive reactance, for a fixed value of inductance, is plotted against frequency. As is evident, the vari-

ation of inductive reactance with frequency is a straight line, which means that inductive reactance varies in direct proportion with the frequency. At zero frequency the inductive reactance is zero. As the frequency is increased, the inductive reactance increases. Doubling the frequency, doubles the inductive reactance. Halving the frequency, halves the inductive reactance. Thus, if a winding has an inductive reactance of 10,000 ohms at 600 cycles,—at 1200 cycles the inductive reactance will be 20,000 ohms and at 300 cycles, the inductive reactance will be 5000 ohms.

Reactance in general, can be looked upon as a sort of resistance offered to the flow of alternating current through the device or unit. At the same time, however, it is necessary to understand that inductive reactance is different from the direct-current resistance of a winding. The former depends upon the presence

Fig. 1. The graph at the right shows that when the frequency of the current flowing through an inductance increases, then the inductive reactance increases also. Inductive reactance is usually referred to as being positive and so is shown above the zero line.

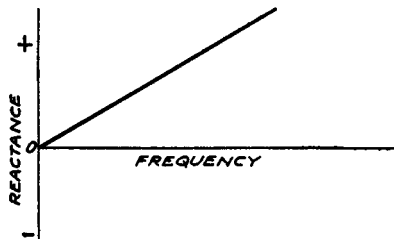

of alternating current, or, expressed in another manner, the application of an alternating e.m.f., whereas the latter is a function of the conductivity of the wire used. It is possible that a coil will have a d-c. resistance of 10 ohms, yet present a reactance of 10,000 ohms at a certain frequency. It is also possible, although not generally true in practice, that a coil will offer a reactance at a certain frequency within the operative range, which is less than the direct-current resistance. Basically speaking, the determination of the reactance does not include or embrace the direct-current resistance of the unit.

Inductive reactance is usually referred to as being *positive*, and is shown above the zero reference line, as in Fig. 1. At the same time, it is necessary to understand that if an alternating e.m.f. is applied to a circuit containing an inductance, then the

current flowing through the inductance is said to "lag" behind the applied voltage. There is a very definite reason for this condition. Expressed in the simplest manner, in order to avoid an elaborate discussion, it is of the following order: When an alternating voltage, or e.m.f., is applied to a coil, current flows through the coil and varies between zero and maximum and changes its polarity or direction in accordance with the rise and fall and change of polarity of the impressed or applied voltage. This change in current intensity sets up a continually varying magnetic field around the turns of the coil. The magnetic lines of force, created as a result of the varying current flowing through the turns, again cut the turns of the coil, and there is induced in the coil, *a counter e.m.f. of self-induction*.

This counter e.m.f. of self-induction opposes any change in the current which causes it. In other words, it tends to keep the current low when the current is increasing and tends to keep the current high, when the current is decreasing. The consequence is that the variations of intensity of the current are not simultaneous with the variations in magnitude of the impressed voltage. By this is meant that the current and impressed voltage are *not in phase*. Expressed differently, the current through the coil does not pass through its maximum point until a short interval after the impressed voltage has passed through its maximum point. The same delay exists between the voltage and current at all other points along the cycle. Such a condition is described by saying that the current "lags" behind the voltage. (More extensive details concerning this phenomenon will be found in the companion volume "Alternating Currents in Radio Receivers.")

Capacitive Reactance

The presence of a condenser in an a-c. circuit introduces an opposition to the flow of the alternating current. This opposition, or hindrance, is referred to as *capacitive reactance*. In contrast to inductive reactance, the opposition offered by a condenser varies inversely with frequency, as illustrated in Fig. 2. Whereas inductive reactance increases with frequency, capacitive reactance decreases with frequency. The inverse relation be-

tween frequency and capacitive reactance identifies that if one is increased, the other decreases. In other words, if the frequency is increased twice, the capacitive reactance decreases to one-half of its original value. For example, if at 1000 cycles the capacitive reactance is 31,840 ohms, at 2000 cycles the capacitive reactance would be 15,920 ohms. If the frequency is increased ten times, the capacitive reactance becomes one-tenth of its original value. Capacitive reactance also depends upon the value of capacity. Increasing the capacity, decreases the reactance and conversely, decreasing the capacity, increases the reactance.

Referring to Fig. 2, you will note that the curve representing capacitive reactance is plotted below the horizontal axis, thereby indicating that it is *negative*. If you remember, the curve repre-

Fig. 2. *When a condenser is connected in a circuit, the capacitive reactance decreases with an increase in frequency. Note that the curve is below the horizontal axis, indicating that the capacitive reactance is always considered to be negative.*

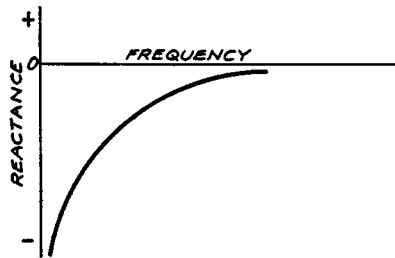

senting inductive reactance was plotted above the horizontal axis. The relation between positive and negative reactance, as mentioned before, becomes of importance when considering resonance problems and will be explained at greater length later in this chapter.

The relation between alternating current and voltage in a circuit containing a condenser is such that the current *leads* the voltage. The reason for the leading current in a capacitive circuit can be explained in the following manner: Assume that a voltage is applied to a condenser and that this voltage starts at zero. As the voltage increases, there is a flow of electrons (current) around the circuit as the electrons are moved from one plate to the other, in accordance with the voltage applied. After a certain interval of current flow, the condenser becomes fully charged to the value of the voltage applied. It is, there-

fore, evident that a flow of current takes place prior to the time that the voltage across the condenser becomes maximum. Consequently, it is said that the current in a capacitive circuit "leads" the voltage. For a more elaborate discussion of this subject, which is not deemed necessary at this time, see "An Hour A Day With Rider On Alternating Currents In Radio Receivers."

No doubt you have experienced practical examples of the relation between capacitive reactance and frequency in connection with bypass circuits. More than likely you have at one time or another discovered that a certain condition, perhaps regeneration, is occasioned by the fact that the value of the capacity, used in any one position in the circuit, is not sufficient to bypass properly the frequencies present in that system. The reactance is too high and proper bypassing is not obtained. By increasing the capacity, the reactance is decreased and a more ready path is offered for the flow of the signal currents and, consequently, they are kept out of harmful paths. It might also be well at this time, to remember that under certain circumstances, when the frequency is very high, it is possible that the presence of a condenser will be the equivalent of a virtual short-circuit to that frequency, because the reactance of that condenser may approach zero or an extremely low figure.

Series Resonance

Having briefly considered inductance and capacity separately, let us now speak about the circuit which contains both capacity and inductance, as, for example, the circuit illustrated in Fig. 3,

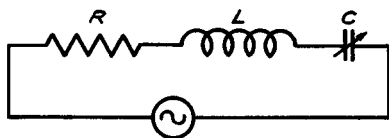

Fig. 3. The fundamental series resonance circuit is shown at the left, containing resistance, inductance and capacity.

where C represents capacity and L represents inductance. We also introduce the resistance R, because it is invariably present in all circuits and because in the final analysis it plays an important part with respect to the operation of resonant circuits,

such as will be considered in connection with alignment procedure.

These three elements, L, C and R, are connected in series and a series circuit is recognized by tracing the path of the current through the system. *A circuit is said to be a series circuit if the current is equal in all parts of the circuit, and if but a single path is offered to the flow of current.* Which is the case in Fig. 3. Check this for yourself. A generator is assumed to be the source of the voltage applied to the circuit.

Now let us suppose that the frequency of the applied voltage is increased, starting at zero. What happens in the circuit? . . . When the frequency is very low, there will be substantially no current, or very little flowing through the circuit; because although the reactance of the coil is very small, the reactance of the condenser at these low frequencies is very great. Now,—if the frequency is increased, the inductive reactance will increase from its low value and the capacitive reactance will decrease from its high value. This is in accordance with Figs. 1 and 2. In accordance with Fig. 1, the inductive reactance increases in a *positive* direction and in accordance with Fig. 2, the capacitive reactance will decrease numerically, and will always remain *negative* throughout the frequency range.

If one reactance is increasing and the other reactance is decreasing, as the frequency is being increased, there will come a time when the frequency will be such that the inductive reactance of the coil will exactly equal the capacitive reactance of the condenser. ***Now, since the inductive reactance is positive and the capacitive reactance is negative, the two will tend to neutralize or oppose each other, and since the two reactances are equal and of opposite sign, in effect, they cancel each other and the net reactance becomes zero. This frequently is termed the "resonant" frequency of L and C, and it can be said that the resonant frequency is that at which the combined reactance of L and C in the circuit is zero.***

No doubt you have noted that in all of the considerations concerning inductive reactance and capacitive reactance, we have omitted the resistor R. This is quite natural since this unit, even if it represents the direct-current resistance of the coil, plays no part in the reactance phenomenon. Since the reactance at the

resonant frequency is zero, you would normally expect that the current in the circuit at this frequency would be very large and this is, in fact, the case. With zero reactance, the current limiting agent is the resistance of the circuit and/or the direct-current resistance of the generator. It is the presence of some resistance which prevents infinite current at resonance. The impedance of the series circuit at resonance is its resistance. Off resonance, the impedance embraces the net reactance and the resistance.

You have noted how we arrived at the resonant frequency of the L and C combination by increasing the frequency from zero. What happens if the frequency is increased beyond the resonant frequency? Referring once more to Figs. 1 and 2, you can see that the reactance of the coil will increase, whereas the reactance of the condenser will decrease. Because of this mode of variation, the balance which existed between the two reactances at resonance is destroyed. When the frequency is above resonance, the reactance of the condenser is decreased, but the reactance of the coil is increased, so that the current flowing in the circuit for frequencies above the resonant frequency, is reduced just as when operation is below the resonant frequency. If the frequency of the voltage applied differs greatly from the resonant frequency, the current through the circuit will be very small. An examination of the table given herewith illustrates the variation of inductive reactance, capacitive reactance and resultant reactance with the frequency of the voltage applied to a series circuit, and advanced towards and beyond resonance. Arbitrary values of inductance and capacity are used. Note that resonance occurs at 1007 kc. at which frequency the two reactances cancel each other.

f kc.	X_L ohms	X_C ohms	X_T ohms
700	110	227	-117
800	126	199	- 73
900	141	177	- 36
1007	158	158	- 0
1100	173	145	+ 28
1200	189	133	+ 56
1300	204	122	+ 82

The relation between circuit impedance and frequency and circuit current and frequency, in a series circuit, is shown in Figs. 4A and 4B. In 4A you will note the change in impedance as the frequency is varied above and below the resonant frequency, and in Fig. 4B you will note the variation in current under similar conditions. Note that when the impedance is maximum, the current is minimum, and when the impedance is minimum, the current is maximum. The reason why the current does not

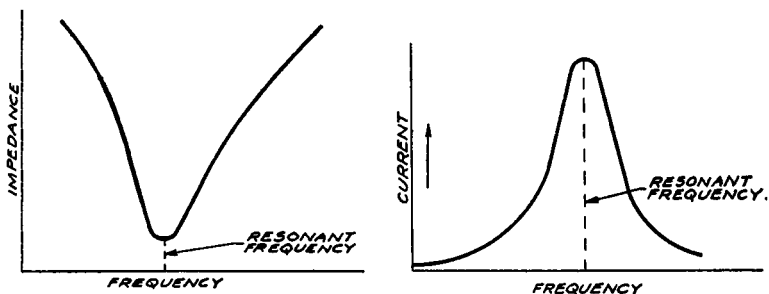

Figs. 4A, left, and 4B. The left curve shows that the impedance is a minimum at the resonant frequency for a series circuit and the curve at the right shows that the current is a maximum at the resonant frequency.

become infinite at resonance is because the circuit impedance never is zero, due to the resistance of the coil. Fig. 4B can be said to be a resonance curve of the series circuit.

Tuning or Trimming

It might be well, at this time, to say a few words concerning the means of attaining a state of resonance when the frequency is fixed. Inductive reactance is a function of inductance as well as frequency. In other words, if, with a fixed value of inductance, an increase in frequency will increase the inductive reactance and a decrease in frequency will decrease the inductive reactance—an increase in inductance with fixed frequency will likewise increase the inductive reactance. Conversely, a decrease in inductance with fixed frequency will, therefore, decrease the inductive reactance. As far as the capacitive reactance is concerned, if the frequency is fixed—increasing the capacity will

decrease the reactance, and decreasing the capacity will increase the reactance. Thus it is possible to obtain the proper balance of reactances so as to produce the state of resonance when the frequency of the voltage applied is fixed, either by varying the inductance and maintaining the capacity constant, or by varying the capacity and maintaining the inductance constant. The latter is usually the method employed. Such is the function of the tuning or trimmer condenser.*

Applications of Series Resonant Circuit

Based upon what has been said so far, you can appreciate the various applications of the series resonant circuit. Bearing in mind that maximum current flows during the state of resonance and that during that time the impedance of the circuit is a minimum, it is possible to accomplish two things. One of these is to utilize the low impedance as a short-circuiting path at the resonant frequency, or as a trap circuit and the second is to employ the device so that maximum current is allowed to flow through the desired circuit at resonance. These two applications though identical in basic design, differ in circuit arrangement and

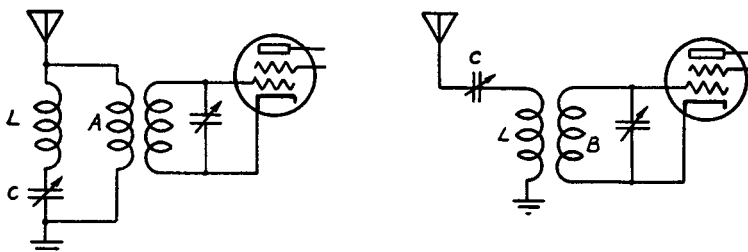

Figs. 5A, left, and 5B. The wave trap, L and C in the left circuit bypasses the current at the resonant frequency and so rejects it. The circuit of Fig. 5B passes on to coil B current at the resonant frequency only.

are shown in Figs. 5A and 5B. In Fig. 5A, the wave trap LC is the series circuit used as a short-circuiting impedance at resonance. It is shunted across the antenna coil A and its purpose is to bypass the current at the resonant frequency. If we assume that the function of this circuit is to bypass an inter-

* See note page 38.

fering signal of, say, 465 kc., tuning this circuit to 465 kc. will prevent the development of a voltage at this frequency across the antenna coil, consequently there would be no signal voltage at this frequency applied to the r-f. amplifier tube. At 465 kc. the reactance of L cancels that of C and there is no net reactance in the trap circuit. The impedance of the circuit, being limited solely by the resistance, is consequently very low; much lower than that of the antenna coil A. The lower the resistance of the circuit, the less its impedance at resonance and the greater its efficiency. The greater the efficiency of this circuit, the less its effect upon signals higher or lower than the resonant frequency. In other words, the sharper the trap.

Another application of the same principle, but employed differently, is shown in Fig. 5B. L and C now constitute the tuned circuit in the antenna system. The impedance is a minimum at resonance, consequently the maximum amount of current flows through the circuit. Coil B, being coupled to L, receives the maximum amount of energy. In Fig. 5A, the resonant circuit is used to trap out or reject a certain signal, whereas in Fig. 5B the same principle is employed to accept the desired signal.

Still another practical application of the phenomena relating to series circuits is the scratch filter used in connection with phonograph pick-ups and audio amplifiers. The series resonant circuit, tuned to the approximate frequency of the scratch noise, is connected across the pick-up and its purpose is to bypass or short-circuit the balance of the system at this noise frequency by offering a low impedance path.

Referring again to Figs. 4A, 4B, 5A and 5B, tuning or trimming a circuit so as to produce the desired state of resonance, is the adjustment of that circuit so that the respective inductive and capacitive reactances balance each other.

The Parallel Tuned Circuit

In addition to series resonance, there is another type of resonance which appears in practically all radio circuits. This is the parallel tuned circuit and resonance in such a circuit is termed *parallel resonance*. As in the case of the series resonant

circuit, the resonant frequency of a parallel circuit is reached when the reactance of the coil is equal to the reactance of the condenser. An example of a parallel resonant circuit is shown in Fig. 6, where L is the inductance, C the capacity and R the resistance. The distinction between the series and the parallel resonant circuits is found in the manner in which the current flows through the circuit. We have stated that a series circuit is one in which there is but one path for the current. In a parallel circuit, however, there is more than one path for the current. In Fig. 6 you will note a capacitive branch and an inductive branch. The presence of R in the inductive branch will receive additional mention later.

Let us for the moment consider each of these branches as a separate entity with respect to the frequency of the applied voltage. At very low frequencies, the reactance of the condenser

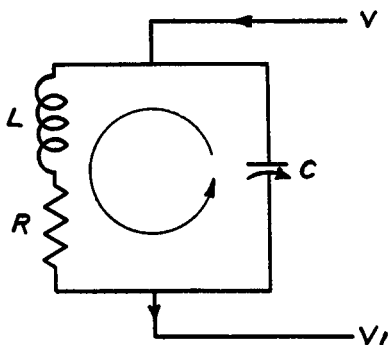

Fig. 6. An example of a parallel resonance circuit is shown at the left. Instead of there being but one path for the current to follow, as in the series circuit of Fig. 3, here there are two paths along which the current can flow. Note that in this circuit the dominating influence with respect to current flow is the lower reactance.

branch is high. Consequently, very little current flows in that circuit. However, at the low frequencies the inductive reactance of L is low. Consequently, the inductive branch carries the major portion of the current. At very high frequencies, the reactance of the inductive branch is very high. Consequently, very little current flows through that branch. However, at such frequencies the reactance of the capacitive branch is very low, so that the major portion of the current flows through that branch. As in the case of the series resonant circuit, at some frequency in between these two extremes, at each of which the impedance of the circuit is low, the impedances of the capacitive

branch and the inductive branch are the same. This is the "resonant frequency."

In the series circuit, we showed that the limitation of current was due to the *higher* of the two reactances. Whether it was the capacitive reactance or the inductive reactance, if one of these was high, as a result of the frequency of the voltage applied, the current through the circuit was small. In the parallel resonance circuit, we find a different condition. In this circuit the dominating influence, with respect to current flow, is the *lower* reactance. If the frequency is such that the capacitive reactance is high and the inductive reactance is low, the total impedance of the circuit is low, because a low reactance shunts the high reactance. If, on the other hand, the frequency is high, so that the inductive reactance is high, but the capacitive reactance is low—the net impedance is still low for the same reason as given above. At resonance, however, both the capacitive reactance and the inductive reactance are of like order and the total impedance is a maximum. There is equal division of current flow through the two branches, but the current through the coil is at every moment opposite to the current through the condenser. This is so because the current through the coil lags behind the voltage, whereas the current through the condenser leads the voltage. The sum result is that the total current through the circuit is very small, hence the impedance of the circuit at resonance is a maximum.

This reference to the minimum current through the circuit should not be confused with the fact that at resonance there is very large circulating current *in the tuned circuit itself*—that is, flowing around L and C. In fact, this circulating current in the tuned circuit may be many times larger than the line current flowing through the tuned circuit. This large circulating current, which is present only at resonance, is due to the energy surging back and forth from the condenser to the coil. Furthermore, because the capacitive reactance balances or offsets the inductive reactance, the net reactance in the tuned circuit is zero. Consequently, the tuned circuit behaves as a pure resistance and may, in fact, be considered as such when computed in radio circuits. The smaller the resistance R of the tuned circuit, the

greater will be the circulating current in the tuned circuit at resonance and the greater is the operating efficiency.

It might be well to elaborate upon the relation between the circulating current in the tuned circuit and the line current through the tuned circuit by saying the following: During the state of resonance, the function of the line current is to be just great enough to supply the circuit losses. In view of the low resistance of the tuned circuit, the energy losses therein are small—consequently the line current is small. The higher the losses in the tuned circuit, the higher is the line current with respect to the circulating current.

The manner in which the impedance of a parallel circuit varies with frequency as resonance is approached and passed is

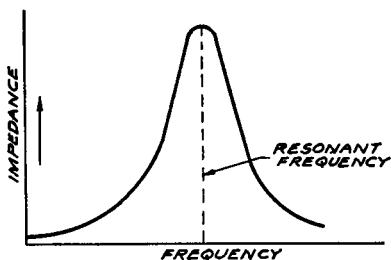

Fig. 7. The impedance of a parallel resonance circuit reaches a maximum at the resonant frequency, which is opposite to the condition for a series circuit, as shown in Fig. 4A.

shown in Fig. 7. Compare Fig. 7 with Fig. 4A. You will note that at resonance, the impedance of the series circuit is a minimum, whereas in the parallel circuit it is a maximum.

Let us examine Figs. 8A and 8B. In Fig. 8A, the parallel circuit, consisting of L_1 C_1 , is in series with the antenna lead and the antenna transformer primary coil A. We can assume that as a result of the signal received, the voltage is applied across the antenna and ground points. These two points would be the equivalent of the two points V and V_1 , shown in Fig. 6. Current flow in this complete circuit, inclusive of coil A, depends upon the tuning of the parallel resonant circuit. If the frequency of the voltage applied is below the resonant frequency, then current will flow in the circuit through the low impedance L_1 branch. If the frequency is above the resonant frequency, current will flow in the circuit through the low impedance C_1 branch. At resonance, however, the minimum amount of current will be

found in the circuit, because, while it is true that the same voltage is being applied, the impedance of the resonant circuit is maximum, and the line current through coil A would be very small. If this applied voltage is a signal voltage, the circuit $L_1 C_1$ serves as a trap to keep the undesired signal out of coil A. All other signals pass through $L_1 C_1$.

Let us now refer to Fig. 8B. L_1 and C_1 are still in parallel and coil L_1 is inductively coupled to coil A. The voltage is introduced through this medium of coupling between coils A and L_1 . What happens in this system?

The voltage developed across a parallel resonant circuit is equal to the current times the impedance. For any condition other than resonance, with the frequency of the voltage introduced via coil A, the impedance of the parallel circuit is low, as has been stated. Consequently, the voltage developed across the circuit is a minimum. However, when the $L_1 C_1$ combination is properly resonated with the frequency of the voltage fed into the circuit via coil A—which may be the signal voltage introduced through the antenna system—the impedance of the parallel

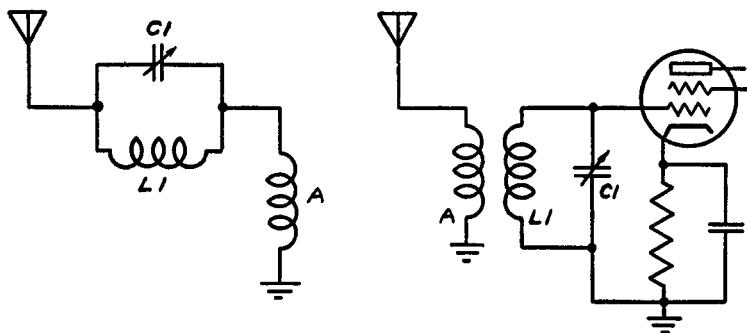

Figs. 8A, left, and 8B. In the circuit at the left, a minimum of current is found in coil A at resonance, while in the circuit of Fig. 8B, the voltage delivered to the grid of the tube is a maximum at the resonant frequency.

resonant circuit is maximum. Consequently, the maximum voltage is developed across the tuned circuit and applied to the input of the tube. By making the efficiency of the parallel circuit very high, so that any unbalance of the respective inductive and capacitive reactances results in a major change of impedance, it

is possible to make the system very responsive to the resonant frequency and lack response off resonance. The greater the efficiency of the circuit, the greater the change of response for a given change in frequency. The circuit shown in Fig. 8B is typical of the average parallel resonant circuit in a radio receiver.

If you now compare Figs. 8A and 8B you will note the difference in application of the parallel resonant circuit. In Fig. 8A the circuit is so arranged that at resonance, influence of the high impedance is such that it keeps a certain signal out of the circuit. On the other hand, in Fig. 8B, the resonant condition and the resonant high impedance enables maximum response at a certain signal frequency. A more detailed explanation of the voltages present across parallel and series resonant circuits will be found in "An Hour A Day With Rider On Alternating Currents In Radio Receivers." Additional material supplementing that which has already been mentioned in this volume on resonance and alignment will be found later on in this chapter.

Parallel Resonant Circuit Most Common

The parallel resonant circuit finds far more extensive application in radio receivers than the series resonant circuit. This condition is not due to any difference in operating efficiency of the two circuits, but rather to the fact that the arrangement of the elements, which comprise the parallel circuit, is such that the coil constitutes a ready path for the application of the operating potentials to the elements of the respective tubes. In other words, the coil in the parallel circuit supplies a continuous path for the plate current and grid current. Another reason for the widespread application of the parallel resonant circuit is that the circuit arrangement makes it possible to place the condenser or the tuning capacity at ground potential, thereby providing freedom from hand and body capacity effects with greatest ease and convenience.

Perhaps the most important reason for the greater use of the parallel tuned circuit as against the series tuned circuit is that the former offers a high impedance at resonance, while, as we have seen, the impedance of the latter at resonance is very small.

Since it is necessary to provide a high impedance load in order to secure any degree of amplification from a vacuum tube, the reason for the more frequent occurrence of the parallel resonant circuit is at once apparent.

Series and parallel resonant circuits, such as have been described, find a number of different applications. In this volume we are concerned solely with applications at frequencies within the i-f. and r-f. bands. As far as alignment operations are concerned, there are two important considerations to remember. One of these is the manner in which the circuit is employed with respect to what is to be accomplished. The second is the electrical phenomenon developed when the trimmer condenser or the tuning condenser is being adjusted. Referring to the former, it is necessary that the man carrying out the alignment procedure understand the purpose of the circuit being trimmed. You must recognize whether the circuit is being resonated to a certain frequency in order to eliminate that signal, or if the circuit is being resonated to a certain frequency in order to build up that signal to maximum level. Both of these objectives can be obtained by means of series as well as parallel resonant circuits.

Effect of Resistance on Series Tuned Circuit

We have explained that due to the relation between the inductive reactance and the capacitive reactance in a series tuned circuit, there is no net reactance at resonance. It was also shown that the current at resonance is limited solely by the resistance of the circuit. The greater the resistance, the lower will be the current. The resistance we are referring to is that represented as R in Fig. 3. The variation of current at resonance in a series circuit for constant voltage input and for varying values of resistance is shown in Fig. 9. This curve is the equivalent of a resonance curve for such a series resonant circuit with various values of resistance.

In connection with the reference to the resistance R , it is not necessary that this be an external resistor or an individual resistor. It is possible that this symbol of a resistor may represent the resistance of the coil. Likewise, it may represent a poor

contact in the circuit or the electrical connections in the system. The three values of resistance shown are arbitrary, selected to illustrate the effect of resistance in the circuit.

It stands to reason that every circuit has a definite amount of inherent resistance, so that a specific finite curve exists. It then becomes necessary, in order that the maximum current be obtained at resonance, to make the circuit structure such that it possesses the minimum amount of resistance. This is a matter of design.

Now—in addition to the fact that the current at resonance is decreased as the resistance is increased—a close examination of the curves shows that another significant fact is developed as the resistance is increased. If this current curve is representative of the ability of the circuit to discriminate between frequencies both sides of the resonant frequency, then it is evident that as the

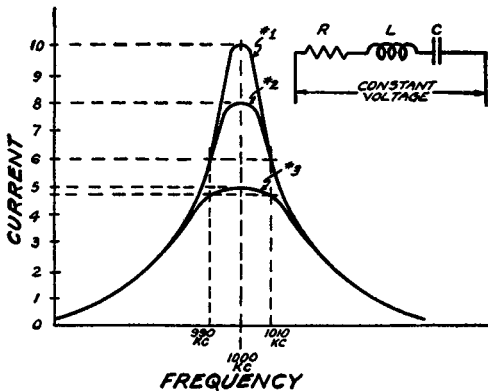

Fig. 9. The group of three curves shown at the left indicates the variation of the current at resonance in a series circuit, shown above, for different values of resistance. In order to get the greatest amount of current at resonance, it is necessary to have a minimum of resistance.

resistance is increased, not only does the current decrease, but the ability to discriminate between frequencies likewise is impaired.

Perhaps this reference to discrimination between frequencies deserves somewhat lengthier comment. The ability of a circuit to discriminate between frequencies both sides of resonance depends primarily upon the ratio between the current in the circuit at resonance and the current in the circuit at some frequency either side of resonance. For example, referring to curve No. 1, if we set an arbitrary value of 1000 kc. as being the resonant frequency, and if we say arbitrarily that the current in the

circuit is 10 units at resonance, the characteristic of that circuit, at whatever value of resistance is present, is such that at 10 kc. off resonance, the current in the system is reduced to 6 units. In other words, if the circuit is resonated to 1000 kc., and some other signal of 990 kc. finds its way into the circuit, the current at this frequency is only 6 units. The same is true if another signal of 1010 kc. finds its way into the circuit when the circuit is resonated to 1000 kc. The greater the current at the resonant frequency, with respect to the current in the circuit at some frequency off resonance, the more readily does the circuit discriminate between the two frequencies, namely, the resonant frequency and the off-resonance frequency. If you will now refer to curve No. 2 in Fig. 9, representative of the same circuit but with a larger value of resistance, you will note that the circuit is still resonant to 1000 kc., but now the current at resonance is only 8 units and at 10 kc. off resonance is still 6 units. This means that the circuit will not discriminate as readily between the 990 kc. and the 1000 kc. signals, because the current off resonance is not very much less than the current at the resonant frequency.

If you will now refer to curve No. 3 in Fig. 9, which is representative of a still greater value of resistance present in the resonant circuit, you will note that the circuit is still resonant to 1000 kc., but that the curve is much flatter. It is no longer as steep as the curve developed with lower values of resistance. If you check the current at resonance, you will find that it is 5 units, and 10 kc. off resonance it is approximately $4\frac{3}{4}$ units. The off-resonance signal develops approximately as much current in the system as the resonant signal. Consequently, such a circuit would not discriminate between the two frequencies, and if such a condition is interpreted in actual practice, it means that the off-resonance signal would interfere with the resonant frequency signal.

What has been said in connection with the off-resonance signal at 10 kc. below the resonant frequency, is likewise true if the interfering signal or the off-resonance signal is 10 kc. above the resonant frequency.

The ability of a circuit to discriminate between frequencies is the ability of that circuit to select between signals and is a

measure of the selectivity of the circuit. The flatness of curve 3 implies directly that the circuit will not be able to respond differently to different frequencies and hence implies that the selectivity of that circuit is poor. Accordingly, we can see that the greater the resistance of the circuit, the less its selectivity powers. Interpreting this entire situation into practice, it would mean that interference would exist and that the amplitude of the signal at the resonant frequency would be comparatively low.

It might be well, at this time, to comment upon the deliberate insertion of resistance in such a series circuit under certain circumstances. Based upon what is shown in Fig. 9, it is clearly evident that varying the resistance of the circuit varies the frequency response of the circuit over a band of frequencies both sides of the resonant frequency. This characteristic is utilized when the series resonant circuit is employed as a trap or a bypass in audio-frequency systems. Perhaps discussion of this subject does not belong in this volume, but a few words will not be amiss. Oftentimes such a circuit is employed to take out or eliminate the scratch noise when an electric pick-up is used in a phonograph installation, or when attenuation or reduction of the intensity of certain audio signals is required in an audio amplifier. Total elimination at the resonant frequency not being desired, the resistance is inserted and by varying the resistance, it is possible to limit the amount of bypassing through the series resonant circuit. Thus we see how under one condition resistance in the circuit is detrimental, and in another case how the resistance is deliberately inserted so as to accomplish a certain effect.

Effect of Resistance on Parallel Tuned Circuit

It is somewhat more difficult to understand the effect of resistance on the characteristics of the parallel tuned circuits without going into the mathematical computations. However, the following can be readily appreciated: We have previously seen how at resonance the electrons surge back and forth from the coil to the condenser. With a minimum of resistance in the circuit, this energy transfer can take place with maximum amplitude. Consequently, the circulating current in the tuned circuit is high. Adding resistance to the circuit, such as R in Fig. 6,

does two things: First it reduces the amount of current circulating between the coil and the condenser. In other words, it damps the circuit. In accordance with what has been said before concerning the function of the line current, loss is introduced as a result of the resistance and tends, in effect, to reduce the impedance of the parallel resonant circuit. With a reduction in the impedance of the circuit, the voltage developed across the circuit is reduced. Because of the damping of the circuit, the change in impedance both sides of the resonant frequencies, is not as great as when minimum resistance exists in the circuit. This means that the selectivity powers of the circuit are impaired as the resistance of the circuit is increased, or, if we say that such resistance represents losses—as the losses in the circuit are in-

Fig. 10. The curves at the right show how the impedance of a parallel circuit varies with three different values of R, see schematic diagram in upper right corner. Note how the resonance curves flatten as the value of R is increased.

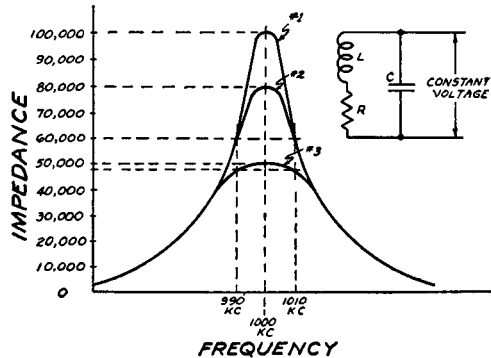

creased. Fig. 10 illustrates the variation in impedance of a parallel circuit at three values of resistance over a band of frequencies.

The curve No. 1, Fig. 10 is for what would be the equivalent of minimum, normal amount of resistance in such a circuit. Note the sharpness of the resonance curve. This is the same in character as curve No. 1 in Fig. 9. In this curve we illustrate the discriminating powers of the circuit by noting the change in impedance as the frequency of the applied voltage is made lower than the resonant frequency and as it is made higher than the resonant frequency. In actual function, Figs. 9 and 10 are similar. Both are selectivity curves, but in Fig. 9 the resonance curve is established on the basis of current change in the circuit,

whereas in Fig. 10, the resonance curve is developed as a result of the change in impedance.

If you examine curve No. 1 in Fig. 10, you will note that the impedance at resonance is 100,000 ohms and at 990 kc., which is 10 kc. below resonance, the impedance is approximately 60,000 ohms. If you now examine curve No. 2 in Fig. 10, which is for a higher value of resistance, the impedance at resonance is approximately 80,000 ohms, and at 990 kc. the impedance is approximately 60,000 ohms. Obviously the change in impedance, as the frequency is changed by 10 kc., is not as great as previously, and if the 990-kc. voltage is that of an interfering signal, the selectivity powers of the circuit would not be great enough to choose between the two signals. Note also that the slope of the curve is not as steep and that the peak of the resonance curve is much broader than is the curve indicative of the lower value of resistance. Curve No. 3 of Fig. 10 is for a still greater value of resistance. Note that the top of the curve is almost flat. At resonance the impedance is approximately 50,000 ohms, and at 990 kc. the impedance is approximately 48,000 ohms—practically no variation in impedance over this 10-kc. band. Obviously the selectivity powers of such a circuit over this 10-kc. band are substantially nil. What has been said concerning the 10-kc. change below the resonant frequency is naturally applicable to 10-kc. above the resonant frequency.

In accordance with what explanations have been given in connection with Figs. 9 and 10, it is clearly evident that superfluous resistance in either series or parallel resonant circuits can be very harmful and should be avoided wherever possible. At the same time, we might remark that there are times when, a small value of resistance may be inserted into a circuit, in order to increase the width of the response curve. Such is the case in high fidelity systems in some of our modern receivers. The relation between the width of the response curve at its peak with respect to fidelity of reception, is discussed later in this chapter under the caption, "Selectivity Requirements."

Shunt Resistance

We have spoken about the series resistance in a series or parallel resonant circuit. It is equally important to keep the

shunt resistance across a tuned circuit as low as possible. Effectively, a resistance shunted across a tuned circuit is equivalent to a resistance in series with the coil and the effects are exactly as described in preceding paragraphs. Shunt resistance will interfere with the selectivity characteristics just as readily as series resistance.

Coupling and Resonance Curves

We have considered the subject of resonance from the viewpoint of balanced reactances. We have also spoken of the current curve or impedance curve of the simple tuned circuit as being representative of the resonance curve. Let us now give some thought to the effect of the coupling of various types of tuned transformers upon the resonance curve. From the practical viewpoint there is very little need for such adjustments, because in the majority of instances, the coupling within the transformer is definitely fixed, and seldom, if ever, subject to adjustment in the field. The only exception to this statement is the type of transformer wherein variable coupling is employed as a form of volume control or as a means of increasing the band width of the response curve. Of course, if the type of coupling used in a unit is such that either an inductance or a condenser is common to the coupled coils, and if this coupling unit is not

Fig. 11. At the right is shown the simplest form of a two-winding transformer. Note that here the primary, P, is untuned, while the variable condenser shunted across the secondary tunes that winding.

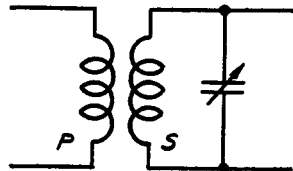

intact and replacement is required, that also constitutes an exception, but when the replacement is made, the original degree of fixed coupling prevails. Nevertheless, in order that you have the proper conception of the reason why certain types of resonance curves are secured with certain types of units, it is necessary to consider the relation between coupling and the shape of the resonance curve. It is our belief that alignment operations are expedited when this is well known.

The simplest of the two-winding transformers found in r-f., i-f. and mixer or first detector systems, is shown in Fig. 11. It consists of an untuned primary P coupled to a tuned secondary S. When establishing the primary and secondary windings, it is customary to designate as the primary that winding in which the applied e.m.f. is found. The other circuit is designated as the secondary. If a third coupled winding is used, that winding is identified as the tertiary winding.

When two windings are linked together through a magnetic or electrostatic field, or have something in common, they are said to be *coupled*. By being coupled is meant that the application of an alternating e.m.f. to the primary winding will result in the generation of a corresponding voltage in the coupled winding or windings, as the case may be.

When two or more circuits are coupled to each other, they react upon each other. The amount of reaction displayed varies under different conditions and is dependent upon the degree of coupling between the windings. The greater the coupling, the greater the reaction. The reaction of one winding upon the other is displayed in two ways: One of these is *the effect upon the selectivity powers* of the unit, consisting of the coupled circuits. The second of these effects is found in the *amplitude of the voltage developed in the coupled circuit*. The second of these effects, expressed from a practical viewpoint, is the effect upon signal output or sensitivity of the receiver.

As a result of variation in coupling, or the degree of reaction between the coupled circuits, the response curve can be made to have extremely steep sides, thereby discriminating to an appreciable degree between the resonant frequency and other frequencies below and above resonance. Then again the shape of the resonance curve can be such that it is wide and has a substantially flat top, so that very little discrimination exists between the resonant frequency and a reasonable range of frequencies both sides of the resonant frequency.

Considering the amplitude of the voltage developed in the resonant circuit, this is the equivalent of referring to the amplitude of the resonance curve. This condition is associated with the shape of the resonance curve, so that it is evident that cou-

pling is related to both selectivity and signal output or sensitivity.

The simple tuned transformer, consisting of a single tuned secondary circuit coupled to an untuned primary circuit, is productive of a resonance curve which has but a single peak at resonance. The peak is sharp and the sides are steep. With respect to the width of the curve, the resonance curve for a complete transformer is somewhat wider than that of the transformer secondary itself—taken with the primary absent. The presence of the primary—untuned though it may be—has the effect of introducing some resistance into the secondary winding. Maximum transfer of electrical energy between the primary and secondary windings develops the resonance curve with the greatest amplitude and this occurs when *optimum coupling* exists. Increasing the coupling beyond this point will reduce the amplitude of the resonance curve and tend to broaden it. Reducing the coupling below the optimum point will likewise reduce the amplitude of the curve and make it narrower.

As far as coupling is concerned, what is said about the simple single tuned circuit transformer is true about all other types—that is, with respect to the results of optimum coupling. The shape of the resonance curve may change with other types of transformers, but there is an optimum adjustment or condition of coupling sometimes expressed as *coefficient of coupling*, which provides maximum transfer of energy. At this time we hasten to add—that with the exception of those transformers which are provided with means of changing the coupling—you who may have occasion to work upon such transformers in connection with the testing or checking of finished receivers, should not take it upon yourselves to change the coupling in the transformers. The desired condition will be obtained by correct alignment. Of far greater importance, as far as the operator is concerned, is that he should know the type of resonance curve to be attained, in accordance with the type of transformer involved. Let us now consider the most popular type of transformer used in modern radio receivers—namely, the double tuned transformer.

The Double Tuned Transformer

The double tuned, inductively coupled transformer is illustrated in Fig. 12. The basic description of such a transformer is one in which two separate circuits, coupled to each other, are tuned to the same frequency. Some variations of this condition will be found in practice as outlined later, but the basic condition is as has been stated. In this transformer, both the primary and secondary are parallel resonant circuits. This is

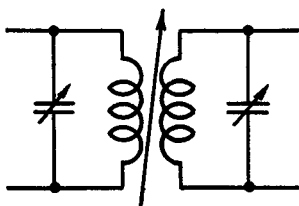

Fig. 12. A conventional i-f. transformer is shown on the left, having both its primary and secondary tuned. The arrow between the windings indicates that the coupling can be varied, the effects of which are explained in the accompanying text.

the common practice as far as receiver application is concerned, but what will be said is just as true if either or both circuits are of the series resonant variety and the inductances in the two circuits are inductively coupled. What happens in this type of unit under two conditions—first, the effect of coupling and second, the effect of incorrect tuning?

What can we expect when the coupling is varied? In accordance with the function of coupling and from what has been said in connection with the simple single tuned transformer, it is more or less obvious that the overall resonance curve is going to depend upon the coupling. In order that the effect of coupling be illustrated in the most practical manner, a conventional i-f. transformer of the commercial variety used in a modern superheterodyne receiver, was arranged to simulate working conditions and in such manner that the coupling could be changed at will. The unit was connected into an oscillograph circuit, so that oscillograms of the overall resonance curve could be taken. The constant voltage input to the transformer was secured from a frequency-modulated oscillator. The two windings were tuned accurately to the same frequency, with minimum coupling between the windings, so that there would be no reaction between the windings and accurate tuning would be possible. (For a

complete resumé of how such curves are made with the cathode-ray oscillograph, see Rider's "The Cathode-Ray Tube At Work.") The amplitude of the response curve for each condition of coupling is representative of the actual performance of the unit under the conditions named. The results are shown in the series of nine oscillograms given in Fig. 13, and are for increasing values of coupling, beginning with the minimum coupling, which would result in the transfer of just sufficient energy so that a resonance curve could be obtained.

The effect of increasing coupling is evident in figures 13-A, 13-B, 13-C and 13-D. As you can see, increasing the coupling from the minimum point results in an increase in energy transfer, until a critical point is reached, where there is no further increase

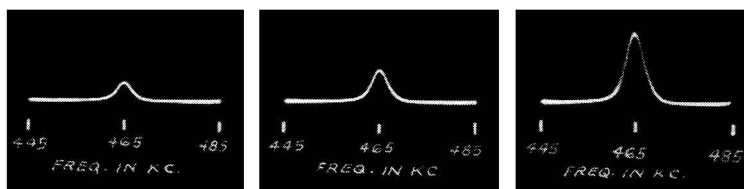

Figs. 13A, left, 13B, middle, and 13C. As the coupling between the two transformer windings is increased, more and more energy is passed, as may be seen from the increasing height of the peak in the three oscillograms above.

in amplitude of the response curve, but there is a slight broadening of the peak. Fig. 13-D illustrates the curve with the slightly broadened peak. During this time, there has been no change in the tuning or the magnitude of the signal voltage fed into the test circuit. The frequency-modulated oscillator supplies a signal voltage which varies from about 445 kc. to 485 kc. twenty-five times per second and is constant in voltage over this range. The periodic frequency or the resonant frequency of the transformer is 465 kc.

Up to this time the effect of coupling increase is to increase the energy transfer. Neglecting the very slight amount of interaction between the primary and secondary, as indicated by the slightly broadened peak, we can say that critical coupling exists. A slight increase in coupling, with everything else unchanged, develops the curve shown in Fig. 13-E. Note that the amplitude

of the curve does not increase, that is, gain through the transformer, but the shape of the curve is changed in that two distinct peaks have appeared both sides of the slight dip in the center. Also that the band-width has increased at the top of the curve, as well as at the base. Note that the dip occurs at the point which was originally the peak and that one peak now occurs below the resonant frequency and another peak occurs above the resonant frequency. A still further increase in coupling develops the curve shown in Fig. 13-F, which illustrates an

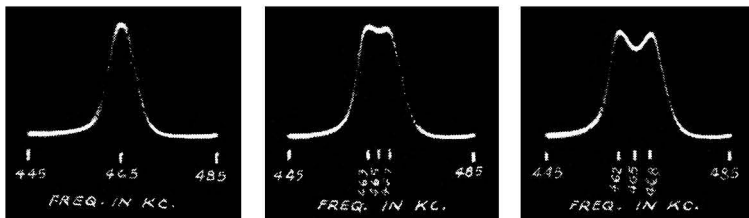

Figs. 13D, left, 13E, middle and 13F. As the coupling between the windings is increased further it reaches an optimum value in Fig. 13D. A further increase results in the development of a peak on each side of the resonant frequency, in this case 465 kc.

accentuation of the condition shown in Fig. 13-E. The dip is more pronounced and there is a slight decrease in the overall-amplitude of the resonance curve. . . . Also the frequency band pass is increased as indicated by the increased separation between the two peaks.

The interaction between the primary and secondary windings, as a result of the higher degree of coupling, is manifesting itself. Coupling which produces a double peaked or double hump resonance curve, is known as *close coupling*. Naturally, there are various degrees of close coupling, as is evident in Figs. 13-E and 13-F and more to follow. The following is a brief explanation of why the resonance curve appears as shown.

For coupling in excess of the critical or optimum amount, the presence of the secondary winding reduces the current through the primary at the resonant frequency. Since the current in the secondary circuit conforms, to a major extent, to the primary current variations, a dip at the resonant frequency occurs. The greater this coupling, the greater is this dip. At frequencies

above and below resonance, the effect of the secondary is to increase the primary current to values greater than those when the secondary is absent. The closer the coupling, the further apart the two peaks and the greater the dip at the resonant frequency—simultaneous with a gradual reduction of the amplitude of the curve. This is shown in Figs. 13-G, 13-H and 13-I, where Fig. 13-I is for maximum coupling possible with the i-f. transformer used in the test.

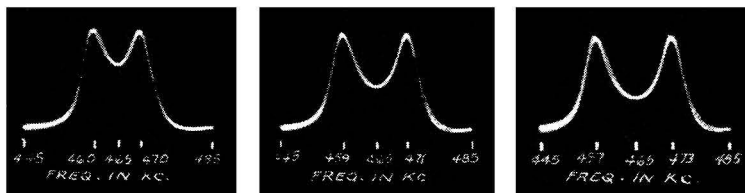

Figs. 13G, left, 13H, middle, and 13I. As the coupling is increased, the frequency at which the peaks occur departs farther from the resonant frequency, as is indicated in the frequency designations under the oscillograms in Figs. 13E to 13I.

When external influences, such as regeneration, are absent, the resonance curve is quite symmetrical. By this is meant that the variations in the curve are essentially the same both sides of the resonant frequency and the amplitude of the two peaks is the same.

Let us now analyse the curves of Figs. 13-A to 13-I, and see what can be learned concerning the resonance curves of such double-tuned transformers. First, it is evident that such a transformer is capable of providing a single peaked or a double peaked resonance curve. Whichever is developed depends upon the degree of coupling. Second, that unless external and undesired influences are present, the curve should be symmetrical. This is of value when the resonance curve is established by any one of the numerous means available, as will be stated later. Third, because of the range of resonance curves possible with such a unit, it is possible to increase the band of frequencies passed by the device—PROVIDING THAT THE COUPLING IS VARIABLE. . . . However, in the event that the coupling is fixed, then the optimum setting is that which can be secured solely by correct tuning. . . . If the design of the transformer

is such that the curve of Fig. 13-D is the correct figure, then the correct tuning and correct conditions will develop such a curve. On the other hand, if the design of the transformer is such that the curve of Fig. 13-E, is the correct curve,—then correct tuning and correct conditions will develop this curve.

Correct tuning can be stated as being that which provides the maximum amplitude for the resonance curve, consistent with the proper frequency band-pass. Information concerning frequency band-pass is given under the heading "Selectivity Requirements," later in this chapter.

What happens if the two windings are not resonated to the same frequency? The major effect is that the two peaks are not of like amplitude. If the frequency of resonance in the

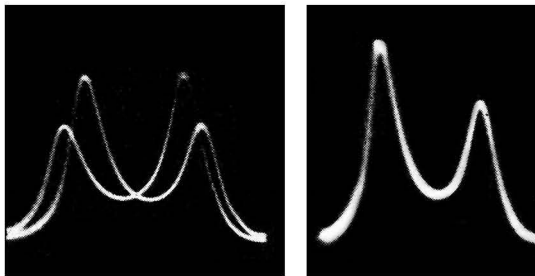

Figs. 14A, left, and 14B. If both windings of a transformer are not tuned to the same frequency, two peaks of unequal heights result. Note that these oscillograms were made with two types of oscillographs, as explained in the text below.

primary circuit does not differ very greatly from the resonant frequency of the secondary circuit, then the two bumps or peaks' will not be far apart, but if these two frequencies differ widely, then the two peaks will be far apart and of uneven amplitude. Another effect is that the dip does not take place at either resonant frequency, but some place between—at least not midway between the peaks, as is the case when both primary and secondary circuit are resonated to the same frequency. Furthermore, the two peaks do not occur at the two resonant frequencies of the primary and secondary respectively. An example of an asymmetrical curve, or one with uneven amplitudes for the peaks, due to incorrect tuning, is shown in Figs. 14-A and 14-B. The former was taken with the double image type of visual alignment method, and Fig. 14-B was taken with the single image

type of visual alignment method. (For the difference between these two systems, see Rider's "The Cathode-Ray Tube at Work.")

Selectivity Requirements

An understanding of the selectivity requirements in the alignment process and how these are related to the quality of reception, is highly desirable, because it establishes the type of resonance curve which should be developed and the advantage of one type of curve over the other. Suppose we consider the frequency composition of a 1000-kc. carrier, which is modulated with a 1000-cycle tone. In actual voice transmission, as practiced by the majority of broadcasting stations, the highest frequency used for modulation is 5000 cycles. In some few instances where high-fidelity transmission is effected, the highest frequency is about 7500 cycles. Referring once more to our example, such a modulated wave consists of three frequencies: the 1000-kc. carrier, the 1001-kc. upper sideband and the 999-kc. lower sideband. This is shown graphically in Fig. 15. If this same carrier is

Fig. 15. If the carrier frequency is 1000 kc. and if this is modulated by a 1000-cycle note, then the frequencies of the two sidebands will be 999 kc. and 1001 kc., as are indicated in the accompanying graph.

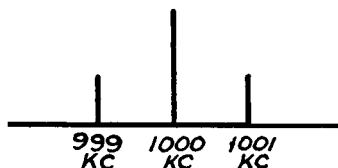

modulated by a 30-cycle tone, the frequencies in the wave are the carrier of 1000 kc., the upper side band of 1000 kc. + 30 cycles and the lower sideband of 1000 kc. - 30 cycles. If the modulating frequency is 10,000 cycles, then the three frequencies are 1000 kc., 1010 kc. and 990 kc.

In these examples we assume a constant tone for modulation. If complex tones are used so that 30 to 5000 cycles is the band of modulating frequencies, then the upper and lower sidebands are limited by the highest frequencies. The carrier frequency remains as before, 1000 kc. The carrier frequency may of course be other than 1000 kc.

Now, an essential characteristic of a receiver is to pass the modulated carrier without any suppression of the sidebands.

This means that those parts of the receiver which are called upon to pass the modulated carrier, should be equally responsive to the sidebands as well as to the carrier. In order that this be so, the ideal response curve required for the various tuned circuits is a square top curve with vertical sides. The width of

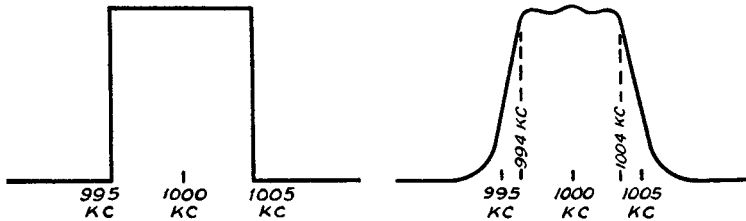

Fig. 16, left. The ideal square topped response curve of a unit passing 5 kc. sidebands.

Fig. 17, right. In practice the ideal flat top of Fig. 16 is approached by response curve of the type shown here and secured as explained in the text.

the top should be the full width of what is classified as being normal sidebands for normal broadcast transmission. . . . With 5000-cycle modulation this is 10 kilocycles, or 5 kilocycles each side of the carrier frequency. This is illustrated in Fig. 16. If the modulating frequency limit is 10,000 cycles, then each sideband is 10,000 cycles wide and the total band-width must be 20,000 cycles or 20 kc.

Up to the present time, square top resonance curves have been impossible to attain, but an approach has been reached. For example the curves of Figs. 13-E and 13-F show a fairly flat top. If you compare Figs. 13-D and 13-E, you will note that while the amplitude or the response of both is substantially the same at the carrier frequency, which in this case is assumed to be the resonant frequency, the response 3.0 kc. each side of the carrier is greater with the adjustment indicated by Fig. 13-E than with the adjustment indicated in Fig. 13-D. In turn, the adjustment indicated in Fig. 13-F, shows greater response at about 5.0 kc. each side of the carrier than either Figs. 13-D or 13-E. At the same time, Fig. 13-F, shows less response at the carrier frequency than either of the other two oscillograms.

In the modern high-fidelity receiver, even a closer approach to the ideal is attained, by developing a curve, such as that

shown in Fig. 13-F or Fig. 13-G, in the i-f. system and depending upon superimposed r-f. selectivity, which is most responsive to the carrier, as shown in Fig. 13-D, to fill in the dip between the two outside peaks. The curve developed as a result of the combination of the response characteristic of the i-f. amplifier with a resonance curve, such as that shown in Figs. 13-G and 13-D, is shown in Fig. 17. The variation in amplitude between the peaks is not sufficient to cause any complications. At the same time, the proper band-pass is obtained and the sides of the curve are a close approach to the straight lines of Fig. 16. The flat top of Fig. 16 is simulated by the top of the curve of Fig. 17.

Variable Selectivity Circuits

The effect of a very sharply tuned amplifier, which has a characteristic similar to that of Fig. 13-D, is to attenuate the outer sidebands and hence to attenuate the higher audio frequencies, which are contained in these sidebands. Thus, excessive selectivity results in reduced high frequency (audio) response. It is for this reason that the intermediate-frequency

Fig. 18. By varying the coupling between the windings of the first and second i-f. transformers, the selectivity of the stage can be varied. Note that the third i-f. transformer has fixed coupling; the response of this is broad enough so that the sidebands are not attenuated.

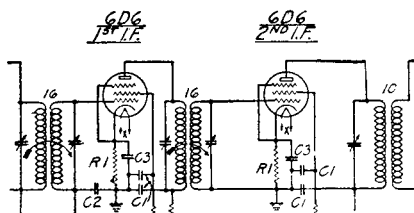

Courtesy Zenith Radio Corp.

amplifiers of almost all the high-fidelity receivers on the market incorporate some arrangement for broadening the response of the amplifiers so as not to lose the higher audio frequencies. If you examine the modern receiver you will find that many systems are in use for accomplishing this result and also that they all depend upon the fact that the frequency response of a transformer becomes broader as the coupling is increased. The time has come to discuss some of the circuits now in use in current receivers.

A direct application of the principles previously discussed is in the Zenith Stratosphere. That part of the receiver which concerns us is shown schematically in Fig. 18. As indicated by the conventional arrow, the coupling in the first and second i-f. transformers is continuously variable. This receiver is representative of that type which uses a mechanical variation of the coupling in a two-winding transformer to accomplish a continuous variation of the selectivity. It is interesting to note that only the first two i-f. transformers are so controlled, the response of the third i-f. transformer being sufficiently broad so that the sidebands are not appreciably attenuated.

The Wells-Garner ODM is typical of the class of receivers which uses a switching arrangement to obtain various degrees of coupling in the i-f. amplifier. Referring to the partial schematic shown in Fig. 19, you can see that a third winding is included

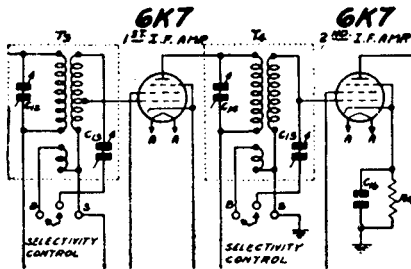

Fig. 19. When the third winding is in the circuit, the coupling is close, giving a broad response characteristic, as is shown in Fig. 13F. With the third coil out of the circuit, the coupling between primary and secondary is loose and the selectivity is sharp.

Courtesy Wells Gardner & Co.

in the first and second i-f. transformers. The primary and secondary are loosely coupled, while the auxiliary winding is closely coupled to the primary winding. The required close degree of coupling is obtained by winding the third coil underneath the primary. By means of the selectivity control switch, this third winding can be put into or out of the circuit. Two values of coupling are provided. With the switch in the "broad" position, the third winding is part of the secondary tuned circuit and the effect is to produce a large value of coupling between primary and secondary. With the switch in the "sharp" position, the third winding is out of the circuit and the resultant coupling is loose. The result is a sharp selectivity characteristic. The coupling in the second i-f. transformer is controlled in the same way and the two selectivity control switches are ganged to form

the overall selectivity control. A general idea of what represents a "sharp" selectivity characteristic is shown in Fig. 13-D and Fig. 13-F illustrates in a general way, a "broad" characteristic.

A slightly different variation of the same principle is used in the Fairbanks-Morse 100. Reference to Fig. 20 shows that the secondary is composed of three sections—L2, L4, and L5.

Fig. 20. When coil L4 is connected in the circuit and, as this is closely coupled to L3, the overall coupling effect is close and the resulting response curve is broad. When L4 is replaced by switching in L5, which is loosely coupled to L3, then the response curve will be sharp, as the main windings, L1 and L2, are loosely coupled.

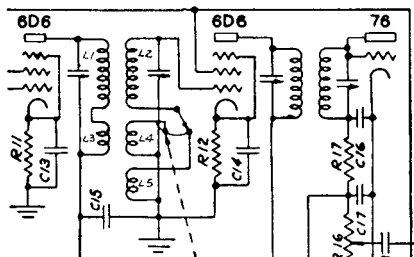

Courtesy of Fairbanks-Morse Home Appliances, Inc.

The primary is composed of L1 and L3. . . . L1 and L2 are loosely coupled to each other and constitute the major portion of the primary and secondary inductances respectively. L3 and L4 are tightly coupled, while the coupling between L5 and the primary is loose. With the switch in the broad position L5 is out of the circuit and the secondary winding consists of L2 and L4. Since L4 is closely coupled to L3, the coupling between the secondary and primary windings is sufficiently great so that a broad response is obtained. With the switch in the "sharp" position, the closely coupled L4 is replaced by L5, which has the same inductance but is loosely coupled. Thus, in this position the overall coupling between primary and secondary is low and hence the frequency response is sharp. The alignment is not disturbed when changing from the sharp to the broad selectivity position.

Up to the present point we have limited our discussion to i-f. transformers wherein selectivity is a function of the coupling between two tuned circuits. A variable selectivity type of three winding transformer in common use is shown in Fig. 21; this is a partial schematic of the Stromberg Carlson Model 70. Note that the first and second i-f. transformers consist of three tuned circuits. Transformers of this type operate in the following

manner: The primary and secondary windings are loosely coupled, while the third or tertiary winding is closely coupled to the secondary winding. When the resistance in series with the tertiary winding is greatest, the tertiary tuned circuit draws practically no current and consequently there is practically no

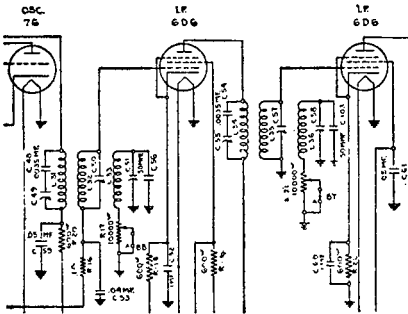

Courtesy of Stromberg-Carlson Tel. Mfg. Co.

Fig. 21. In series with each tertiary winding will be seen a variable 10,000-ohm resistor and this controls the effective coupling between the windings. With this resistance maximum, the tertiary circuit draws practically no current and so there is no reaction between it and the other windings, making the overall selectivity sharp. The less resistance in the circuit, the broader the selectivity.

reaction between it and the other windings. Thus the transformer operates as an ordinary loosely coupled two-winding transformer to provide normal, sharp selectivity and reduced band-width. In the maximum selectivity position, a switch operated by the selectivity or fidelity control, opens the tertiary tuned circuits completely. Now let us see what takes place when the third winding is in the circuit and the resistance in the tertiary tuned circuit is decreased. This circuit, being tuned to the i-f. peak, acts as a load across the secondary winding, abstracts energy therefrom, and results in a broadened response. This effect is most pronounced, of course, when all resistance is out of the circuit, for then a maximum current flows in the tertiary circuit and there is a maximum broadening of the frequency response. This is the high-fidelity position and results in a selectivity characteristic similar to Figs. 13-E or 13-F.

The Philco 201 is another example of a receiver using three winding i-f. transformers, with a variable resistance in series with the tertiary winding to control the selectivity and band-width. At this stage you may be interested in the manner in which the response characteristic of such three-winding transformers change during manipulation of the control.

The three oscillograms in Fig. 22 indicate how the form of the selectivity curve changes with the magnitude of the resistance in the tertiary tuned circuit. Fig. 22-A is the response of an amplifier employing two transformers of this three-winding type and one closely coupled two-winding i-f. transformer; this is for maximum selectivity or maximum resistance in the ter-

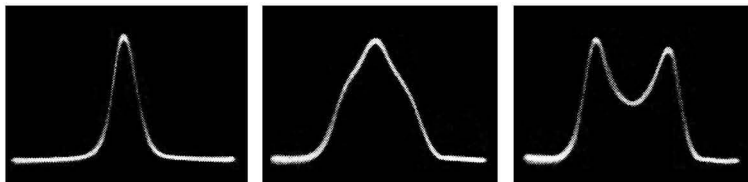

Figs. 22A, left, 22B, middle and 22C. With a maximum resistance in the tertiary winding circuit of a three-winding transformer, shown in Fig. 21, the resulting response curve is sharp, as in Fig. 22A. With a decreased amount of resistance, the curve broadens out, as in Fig. 22B and a greatly increased band-width results with no resistance, as in Fig. 22C.

tiary circuits. Fig. 22-B is the response of the same i-f. amplifier with an intermediate value of resistance in the tertiary circuits. Note how the selectivity is broadened as against the sharp response of Fig. 22-A. With no resistance in the tertiary circuits, the absorption of energy at the peak frequency results in the familiar dip and greatly increased band-width, as is shown

Fig. 23. The third winding of the i-f. transformer on the right picks up a certain portion of the plate voltage and feeds it back to the screen circuit in correct phase. This prevents any tendency towards oscillation and so is really a stabilizing factor, having nothing to do with the degree of coupling between the windings.

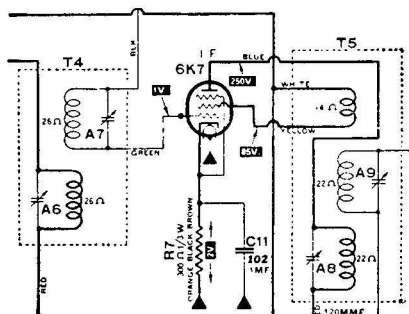

Courtesy Atwater Kent Mfg. Co.

in Fig. 22-C. An intermediate setting between Figs. 22-B and 22-C results in a flat top.

While on the subject of three-winding transformers, the function of the transformer used in the Atwater Kent 856, Fig.

23, is not to provide a control over the selectivity, but to make possible increased gain in the i-f. stage by stabilizing the amplifier. This, as can be seen from the schematic, is accomplished by using the third winding to feed back a portion of the voltage from the plate to the screen circuit in the correct phase to prevent any tendency toward oscillation.

In the oscillograms shown in Fig. 13, we showed how the gain as well as the selectivity was dependent upon the degree of

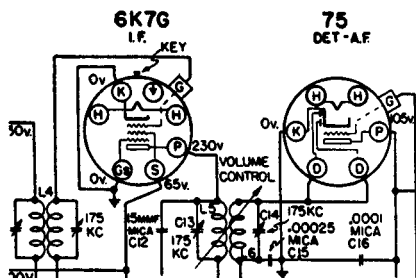

Courtesy Sears-Roebuck & Co.

Fig. 24. The variation of the volume of the set of which a portion of the schematic diagram is shown at the left, is effected by varying the coupling between the primary and secondary of the output i-f. transformer. The coupling is always quite loose, so that the selectivity remains sharp.

coupling. A practical example of such gain control is shown in Fig. 24. The volume control in this receiver is effected by varying mechanically the coupling between the primary and secondary of the last i-f. transformer. It should be noted that there is no appreciable change in selectivity with this arrangement, since the coupling is at all times sufficiently loose so that there is negligible reaction between primary and secondary. This arrangement is used in several receivers made by Sears-Roebuck.

Note Permeability Tuning

Another method is to vary the inductance by the positioning of an iron core inside the coil. In some of the later RCA receivers, the i-f. transformer windings are shunted by a fixed condenser and the inductive reactance is adjusted for resonance by varying the position of the iron core within the transformer windings. A variable core is used for each winding.

Chapter II

ALIGNMENT PROCEDURE

THE purpose of this chapter is not only to discuss the actual procedure involved in the alignment process, but also to explain the "why" behind the various steps in the operation. A clear understanding of the reasoning involved in the multitude of adjustments that constitute the alignment of present day receivers will go far toward simplifying and improving the quality of the job.

We shall first make certain observations which are common to every type of alignment work and it should be understood that these apply in every case. To avoid the necessity for repeating them over and over again, we shall enumerate them here and take it for granted that you will bear them in mind as you progress through this book.

Signal Generator and Test Oscillator

The necessity for a good signal generator cannot be over-emphasized. It is unfortunate that in the past its value as a service instrument has been grossly underestimated. Past years have witnessed operation without a signal generator, but today it is impossible to service modern single, dual, and multi-band receivers properly without possessing a good signal generator. Fortunately, many types of generators are available; some are expensive and others on the market are at a price which puts them within the reach of every service man. Whichever signal generator is selected, it should be stable, well shielded, have a good attenuator, and be capable of covering the range of frequencies commonly in use, either by means of fundamental frequencies or by means of harmonics.

It may be well at this point to clarify our position as to the

use of the terms *signal generator* and *test oscillator*. In this book we are intentionally using the designation "signal generator," whenever referring to an instrument which is used for generating a standard signal.

However, it so happens that in the past, instruments of this type used in the service field have been widely known as "test oscillators" rather than signal generators, the use of the latter term having been confined for the most part to high quality instruments used in research and design work. Frankly speaking, there is no real reason why all signal generators, regardless of price, should not be known as such and this is one of the reasons why we have adopted this term throughout the book. A more important reason is that it is very often necessary to talk about the oscillator in a superheterodyne and a signal generator at the same time. This leads to unnecessary confusion between the oscillator in the receiver and the "test oscillator" and this, to us, is a more important reason for the universal adoption of the designation "signal generator." Whenever, then, the term signal generator is used in this book, let it be understood that it is synonymous with test oscillator and is used because it is a more apt designation and because it minimizes confusion.

Need for Alignment

The alignment adjustments of a receiver should not be changed before the person working on the receiver has satisfied himself that the poor performance of the receiver is due to misalignment of the tuned circuits. There are many reasons why realignment is necessary but there are also other troubles in receivers. In the first place, changing tubes often may throw a receiver out of alignment because of lack of uniformity in the interelectrode capacities of the tubes. This is especially important where metal tubes are *substituted* for glass tubes. A change of this nature should always be accompanied by a complete realignment of the receiver. Movement of r-f. and i-f. wiring may necessitate realignment, because changes in the position of the wiring influences the tuning of the circuits. This is especially important on the short-wave bands, particularly in the case of

sets which have an ultra-high-frequency band. Under no condition should the r-f. wiring, associated with this last named band, be changed, because the distributed capacity and inductance of the wiring usually is an appreciable part of the total capacity and inductance for these bands.

The aging of vital parts associated with the tuned circuits of the receiver is another important factor which makes realignment of receivers necessary at certain intervals. The interval at which realignment becomes necessary will, of course, vary, depending upon the construction of the receiver—particularly the types of trimmers—whether they are of the air dielectric or mica type. Excessive vibration and jarring of the receiver should be avoided as this tends to disturb its alignment.

General Considerations

When the service man has satisfied himself that the performance of the receiver can be improved by alignment, in general, the first step is to consult the manufacturer's instructions relative to the alignment of the receiver in question. Specific alignment data, as supplied by the manufacturer, will be found in "Rider's Manuals." We stress the importance of this step, because, in the last analysis, the alignment procedure depends upon the design of the receiver and the manufacturer is best qualified to state the special steps in the process of aligning his particular set.

While it is true that in the great majority of cases the alignment follows along the same general lines, at the same time, a number of receivers require definite departures from the established routine.

In some receivers it will be found that the r-f. and oscillator coils are exposed and that no metal bottom is provided for the receiver chassis. In these cases, if the test bench has a metal top, then the alignment adjustments reached under these conditions will be in error when the chassis is installed in its wooden cabinet. For these reasons it is generally advisable that alignment operations be carried out on a bench provided with a wooden top. On the other hand, if the receiver has a metal bottom, this should be in place during alignment.

Trimmer Adjustments

To avoid hand capacity effects, the receiver should be grounded, and all tube shields should be in position. The screwdrivers and socket tools used for alignment work should contain little metal—the less the better. To check whether the presence of the alignment tool is disturbing the alignment, observe whether there is a change in output as the tool is removed from the trimmer. If there is a change, the trimmer must be adjusted by successively turning the trimmer in small steps, each time removing the tool and noting the output reading. That adjustment which gives the greatest reading with the tool removed is the correct one. This precaution is to be especially observed in peaking oscillator trimmers on the short-wave bands. Incidentally, before attempting to peak a trimmer, it is a good plan to make sure that the trimmer belongs to the band which is under alignment. As a general rule, the whole alignment process should be repeated as there is a certain amount of reaction between the various stages.

A trimmer should never be left loose in its minimum capacity position; if necessary, bend the end plate so that the nut rests firmly against the plate. With alignment completed, it is advisable to seal the trimmer or tighten the lock nuts, as the case may be. In applying sealing compound, care should be taken to see that it does not run down between the plates of the trimmer, as this will introduce serious losses and detune the resonant circuit. Use the sealing compound very sparingly, and check to see that there is no change in sensitivity after applying it; this can be done by watching the output meter as the trimmer is being sealed. If a change occurs, correction is necessary.

Use of the "Tuning Wand"

It is desirable where possible to determine whether the setting of a trimmer is initially correct before making any change in its adjustment. Where the coil associated with the particular trimmer is not completely shielded, and is accessible to the extent that the end of a rod can be inserted into the winding form, such a test can be made. Such a rod is known as a "tuning wand."

The tuning wand consists of a bakelite rod, one end of which is attached to a small brass cylinder and the other end of which is attached to a core of finely divided iron particles—similar to that used in the new iron core i-f. and r-f. transformers. The brass end of the bakelite rod, if inserted in the magnetic field of a coil, will decrease the effective inductance of the coil. On the other hand, if the iron core end is inserted at one end of the coil, then the permeability of the iron core acts to increase the inductance of the coil. Inserting the iron core end lowers the resonant frequency of the tuned circuit and inserting the brass end raises the resonant frequency. To check the alignment, the signal generator and output indicator are connected to the receiver in the usual manner and the effect upon the output of inserting each end of the tuning wand is noted. In carrying out this operation, the tuning wand should not be inserted to a depth greater than that necessary to determine whether the effect is a decrease or increase in the output.

If the tuned circuit is in perfect alignment, then insertion of either end will reduce the output. On the other hand, if the trimmer capacity is too high, then a decrease in inductance will compensate for this and thus insertion of the brass end will increase the output and insertion of the iron core end will reduce the output. If the trimmer capacity is too low, then an increase in inductance is required to bring the tuned circuit to resonance. This can be accomplished by inserting the iron core end. In other words, if insertion of the iron core end raises the output and insertion of the brass end lowers the output, then the trimmer capacity is too low and can be compensated for by increasing the trimmer capacity. The interpretation of the tuning wand readings is indicated in the following table:

<i>End of Wand</i>	<i>Output</i>	<i>Trimmer Capacity</i>
Brass	Decreases	Do not change
Iron	Decreases	
Brass	Increases	Decrease
Iron	Decreases	
Brass	Decreases	Increase
Iron	Increases	

In general, turning the alignment tool clockwise increases the trimmer capacity and turning the tool counter-clockwise decreases the trimmer capacity.

Regeneration

Where the trimmer adjustments are extremely critical, it is probably due to the presence of regeneration. If a visual method of alignment is being used, then the regeneration will be readily apparent. More will be said about this in the chapter on visual alignment. Before the alignment of such a receiver is attempted the regeneration should be eliminated or at least minimized so that it does not influence the tuning. *It is to be understood that the remarks made here do not apply to those receivers in which regeneration is intentionally introduced by the manufacturer.*

Warm-up Period

Before the *final* alignment adjustments are made, it is a good plan to allow the receiver to reach its normal operating temperature by having it operate for at least 15 minutes. This precaution is especially important on the short-wave bands, where changes in oscillator frequency, due to temperature effects, are especially important.

AVC Adjustment During Alignment

Receivers equipped with AVC require that special attention be given to the signal input to the receiver during alignment. A good general practice to observe is to set the volume control at maximum and feed the weakest possible signal consistent with a reasonable deflection on the output indicator. In this way it is possible to operate below the point at which the AVC circuit levels off the response. When aligning receivers which do not employ AVC, it makes no difference whether the signal level is high or low, providing, of course, that the input is not high enough to cause overloading. The effect of overloading is to broaden the selectivity curve and hence to cause incorrect peaking of the trimmers.

In noisy locations it will be impossible to operate with a signal strength low enough so as to work on the lower portion

of the AVC curve. Under these conditions several courses are open. Instead of working so as to nullify the AVC action, this is used to serve as the output indicator. In a system incorporating AVC, the bias on the controlled tubes of course depends upon the strength of the signal which reaches the AVC rectifier, which may be the second detector or a separate tube employed for this purpose. Now, if, due to improper alignment, the signal reaching the AVC rectifier is low, then the control voltage will be low. On the other hand, if the trimmers are adjusted to resonance, then the signal at the AVC rectifier is increased and the control voltage correspondingly increased. But an increase in control voltage is evidenced by a decrease in the plate current of the controlled tubes; thus a milliammeter inserted in series with the plate supply lead of one of the controlled tubes or in series with one cathode of the controlled tubes can be used to function as a resonance indicator.

We discussed the necessity for working below the AVC level when aligning a receiver by means of the ordinary type of output indicator, which depends for its action upon the audio output of the receiver. We also mentioned the fact that it was possible to align a receiver incorporating AVC with a signal of normal strength, if the operation of the output meter is made to depend upon the AVC action taking place in the receiver. The discussion of output indicators to follow will be divided into two parts—first those which depend upon the audio output and second, those which depend upon the AVC action.

Output Indicators in Audio System

The most generally used output indicator consists of a rectifier type a-c. voltmeter, 1000 ohms per volt, connected across the primary of the output transformer, as indicated in Fig. 25. The blocking condenser, which may be in the indicator or externally connected, has a capacity of about 1 mfd. The 5-volt range provides more than ample sensitivity, even where the receiver incorporates AVC and the alignment must be carried out with a weak signal.

A somewhat similar arrangement is to use a low range a-c. voltmeter across the speaker voice coil; or the voice coil can

be opened and an a-c. milliammeter connected in place of the voice coil. The last two arrangements offer the disadvantage of requiring meters not generally available and do not have any advantage over the output meter first described.

If the output stage consists of two tubes in pushpull, the output indicator can be connected from the plate of one tube to ground, as previously described, or if so desired it can be connected from plate to plate of the pushpull tubes. The latter

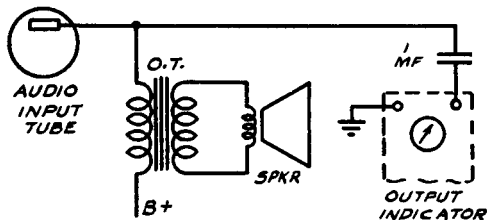

Fig. 25. The output indicator here shown is a rectifier type a-c. voltmeter. The 1-mf. condenser is sometimes incorporated within the meter. A range of 5 volts for this meter is ample.

arrangement has the advantage of not subjecting the blocking condenser to the plate voltage, but generally is not so convenient to connect. It might be well to point out that if an external blocking condenser, such as in Fig. 25 is used, it should be rated at about 600 volts to avoid possibility of breakdown and consequent meter burnout.

An output indicator employing a neon tube and a tapped step-up transformer, has been on the market for some time. The instrument is connected across the voice coil and the tapped primary provides a range of three impedance values. The intensity of the glow tube is used to indicate the audio output.

Where a triode detector is used, a d-c. voltmeter across the detector bias resistor can be used. This should be a low-range, high-resistance meter, or, if desired, a milliammeter can be inserted in series with the plate supply lead feeding the second detector. The best position is between the low end of the load and the B supply. This meter should have a full scale range of about 1 to 2 milliamperes, depending upon the type of coupling used between the detector tube and the succeeding audio stage. The maximum range of the meter also depends upon the type of detector used, that is, whether it is of the power detector type or of the conventional type. The lower range meter can be used with

resistance-coupled detectors and with power detectors. The higher range is preferable with transformer-coupled detectors. These two types of indicator systems are somewhat limited in their application and, with the exception of the fact that they do not require that the test signal be modulated, offer no advantage over the simple a-c. voltmeter and blocking condenser unit connected across the primary of the output transformer.

Output Indicators Based Upon AVC Action

We now come to the class of output indicators which depend upon AVC for their operation. As previously explained the magnitude of the AVC voltage generated depends upon the alignment of the tuned circuits. As the circuits are brought into alignment, the AVC voltage increases. Thus the indication of a very high-resistance voltmeter connected across the AVC bus can be used to meter the output. A simple vacuum-tube voltmeter will serve very well to indicate this voltage. However the ordinary high-resistance voltmeter is not suitable, as it will upset the AVC system. A simple vacuum-tube voltmeter is shown in Fig. 26. A 50-ohm rheostat is shunted across the meter to pro-

Fig. 26. A simple vacuum-tube voltmeter, connected as in the accompanying schematic, can be used to measure the output of a receiver in which is incorporated AVC.

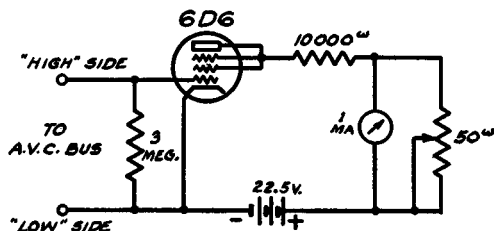

vide some control over the sensitivity of the instrument. In practice the rheostat is set so that the meter reads full scale. The input terminals are connected to the AVC bus and the trimmers adjusted so that the reading is a minimum. As the circuits are brought into alignment, the shunt resistance should be increased so that the meter always reads well up on scale. The "low" side of the vacuum-tube voltmeter should be connected to the cathode at the second detector or AVC tube.

Another useful method in aligning AVC receivers is to disconnect the AVC supply lead at the AVC tube (or the second detector) and to use a fixed value of C bias while the alignment is effected. This fixed bias is inserted in series with the AVC supply lead. In this way an ordinary output meter can be used to carry out the alignment, without regard to keeping the signal input to a very small value. This procedure is especially useful where trouble is suspected in the AVC system.

Another method already mentioned in brief is the use of a low-range d-c. milliammeter in the plate circuit or the cathode circuit of one of the AVC controlled tubes. The more perfect the state of alignment, the greater the signal voltage fed into the AVC tube, consequently, the greater the control bias voltage fed to the controlled tubes. This control bias reduces the plate current, hence the greatest reduction in plate current in the controlled tube cathode or plate circuits, is indicative of maximum signal strength, hence best alignment. The same principle applies to the use of the meter in the cathode circuit of the controlled tubes. Such a meter should have a full scale range of about five milliamperes.

Still another method is the use of a low-range, high-resistance voltmeter across the fixed bias cathode resistor in the controlled tube circuits. The greatest decrease in fixed bias voltage, as the result of the decrease in plate current, indicates that the highest bias has been applied through the control circuit, and is indicative of the greatest signal input into the AVC tube, hence, best alignment.

The use of the resonance indicators described above offer certain advantages over the audio output type. In the first place they do not require that the signal input to the receiver be of extremely small magnitude. The use of a very small signal, of course, means that the receiver is operating at maximum sensitivity during the alignment operation—hence is susceptible to noise pickup, especially on the short-wave bands. In very noisy locations, this is a serious handicap and in severe cases necessitates the use of screened rooms. With the AVC type of indicator, this difficulty is overcome since the signal used is almost always of greater intensity than the noise voltage pickup.

Chapter III

ALIGNMENT AND NEUTRALIZATION OF TRF RECEIVERS

IN ORDER that this material be presented in the most comprehensive manner, we are going to separate the TRF receiver which does not contain any method of neutralization from the TRF receiver which contains a neutralizing arrangement. The reason for making this division is that the alignment process, as applied to a neutralized TRF receiver, is secondary to the process of neutralization. By this is meant that neutralization is the first requirement, since an unneutralized state interferes with correct alignment of the receiver. . . . We will start with the TRF receiver which does not require neutralization.

As far as alignment procedure is concerned, such receivers involve two varieties of alignment adjustments. One of these is the receiver which has regular trimmers in shunt with the main tuning condenser. The second type of receiver is that which employs tuning condensers with slotted end plates and the segments of these end plates constitute the trimmers. As a general rule, those receivers which contain trimmers in shunt with the tuning condensers employ these "high-frequency" trimmers for alignment at 1400 kc. or thereabout. Receivers with slotted end plate condensers are aligned at the respective frequencies which occur when each one of the segments is alternately fully meshed.

The first step in the actual alignment procedure is to place the receiver in operation with all trimmers accessible and all shields in place. It is understood that the operating voltages have been checked and are correct. The lack of sensitivity and selectivity is apparently due to misalignment.

Connect the signal generator to the receiver through a dummy antenna, consisting of a .00025-mfd. condenser and a 200-ohm resistor, as shown in Fig. 27. Check the dial position. Turn the condenser shaft until the tuning condenser plates are fully meshed. Generally, a reference mark is provided by the set manufacturer for the purpose of indicating the position which represents a fully meshed or fully open condenser. Set the condenser so that the reference mark on the dial coincides with the reference mark on the chassis. Inspection will readily determine whether the refer-

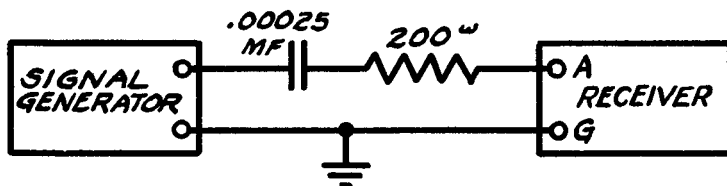

Fig. 27. The output of the signal generator is connected to the receiver through a dummy antenna consisting of a .00025-mf. condenser in series with a 200-ohm resistor.

ence mark is for the condenser plates fully unmeshed or fully meshed. Where the cabinet escutcheon constitutes the dial pointer, a temporary pointer should be provided and centered, so that its position corresponds to that of the escutcheon. A piece of stiff wire, properly mounted and bent, will serve the purpose well.

Tune the receiver to 1400 kc., unless some other alignment frequency is specified or is indicated by the dial markings. Now tune the signal generator to 1400 kc. and with the receiver volume control on full, adjust the output of the signal generator so that the output indicator, used during the test, reads about half of the full-scale deflection. (See text on output indicator.) Now adjust the various trimmers, *working from the detector towards the antenna*. In each case adjust for maximum output indication upon the meter. It may be necessary to reduce the output of the signal generator in order to maintain the meter reading within the limits of the instrument. . . . After all adjustments have been completed, they should be repeated so as to assure correct alignment at whatever frequency is used for this test.

In the event that the condenser end plates are slotted and these segments are used as the trimmers, the tuning condenser is first completely unmeshed and then the high-frequency segment is fully meshed by turning the condenser through the proper arc. Adjustment of this segment may be controlled by a screw, or it may be necessary to bend the end plate. Whichever is required, the adjustment is the same as if it were a regular trimmer.

The next step is to check the alignment of the receiver at other frequencies throughout the band. In a large number of receivers, adjustment at frequencies other than the highest frequency within the band is accomplished by changing the position of the segments of the slotted end plate. Alignment is effected by bending the segment away from or toward the adjacent plate of the condenser. The former decreases the capacity, and the latter operation increases the capacity. During the past few years, the trend has been toward precision manufacture of condenser gangs and in practice you will find that the necessity for bending plates will seldom occur. An example of a condenser with slotted end plates and in which segments are adjusted with screws is shown in Fig. 28.

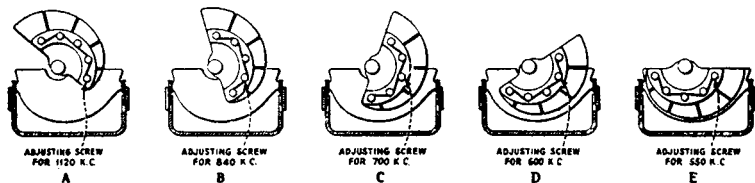

Courtesy RCA Mfg. Co.

Fig. 28. The slotted end plates of a variable condenser are adjusted with screws to secure alignment at the frequencies indicated.

Alignment of dual-band TRF receivers, which are not provided with special high-frequency trimmers for the short-wave band, may require a slightly different mode of attack. Alignment of the broadcast band is carried out as already stated. Alignment of the short-wave band, however, may require movement of the last turn or two of the short-wave coil in order to align the circuits. Moving these few turns closer to the other turns of the winding will increase the inductance. Moving the turns away from the remainder of the winding upon the coil will decrease the inductance. As a general rule, the short-wave band in such TRF. receivers is created by shunting a short-wave coil across the regular broadcast coil. In some cases, a switch inserts the short-wave coil into the circuit and it is tuned with the regular tuning condenser. However, in order not to upset the adjustment at the broadcast band, it is preferable, if at all possible, to align the short-wave band by means of inductance varia-

tion and such alignment is carried out only at the high-frequency end of the band.

Synchronizing Variable Condensers

Many of the old TRF receivers are not provided with trimmer condensers, but have an individual adjustment for synchronizing the condensers, which are driven by a single control.

If the synchronism has been disturbed in a belted type receiver, the condensers can be resynchronized by loosening the pulley set screws and adjusting the rotor of each condenser to give peak output on a constant-strength signal of 1000 kc. The pulley screws are then tightened and if the condensers and r-f. transformers are matched, the synchronism should be good at all other points on the dial. If the sensitivity of the receiver is poor at other points in the band, then either the condensers or the r-f. coil group are not matched. In this case a new condenser group or a new transformer group (as necessary) should be installed and the condensers should be resynchronized.

In making adjustments of this type, there is always a tendency for the rotor to shift as the screw is being tightened. For this reason the maximum reading on the output indicator should be noted just before the screw is tightened and if the reading is less after the screw is tightened, then the adjustment should be repeated until the reading, when the screw is tightened, is the same as the original maximum indication on the output indicator.

Neutralization of Tuned R-F. Receivers

Since the commercial advent of the screen grid tube in 1930 the necessity for neutralization has disappeared and is not likely to make its appearance again in radio receivers. Nevertheless, the fact that many receivers manufactured prior to this date incorporated a neutralized circuit makes it desirable to devote some space to this subject.

When a triode is used as an r-f. amplifier, the capacity between the grid and plate of the tube becomes very important, because it serves as a means for an interchange of energy between the plate and grid circuits. This feedback of energy is generally great enough to cause serious instability and oscillation. Prior

to the time at which screen grid tubes became available, many receivers used a circuit in which a portion of the voltage from the output circuit of the neutralized stage was fed back to the grid circuit in order to cancel the voltage induced on the grid through the grid-plate capacity. This process is called *neutralization*.

Neutralizing Procedure

While it is true that many types of neutralization circuits have been used, they all depend in the main upon the same basic principle, namely, upon a voltage balance which cancels out the feedback through the internal grid-plate capacity of the tube. . . . As far as we are concerned, the important item is that the neutralizing technique follows along the same lines for substantially all neutralizing systems.

In Fig. 29 is shown a partial schematic of the Majestic 90 and the neutralizing condensers are indicated as C1, C2, C3, and C4, there being four r-f. stages and a neutralizing condenser for each

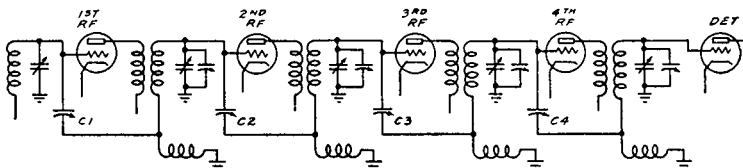

Fig. 29. The neutralizing condensers, C1, C2, C3, and C4, are used to balance out the coupling introduced through the grid-plate capacity of the tubes.

stage. Each stage is individually neutralized by means of its own neutralizing condenser. The operation consists of adjusting the capacity of the neutralizing condenser to balance out the coupling introduced through the grid-plate capacity. This is most easily effected by the use of a dummy tube, that is, a tube similar in every way to the tubes used in the r-f. amplifier, but with one heater or filament prong removed. With this dummy tube inserted in the stage being neutralized, the associated neutralizing condenser is adjusted for *minimum* output.

Referring to Fig. 29, the signal generator and receiver are placed in operation and tuned to about 1000 kc. The signal gen-

erator is adjusted to give a good reading on the output meter. To neutralize the fourth r-f. stage, the fourth r-f. tube is replaced by the dummy tube. It will now be necessary to increase the output of the signal generator and at the same time the neutralizing condenser C4 is adjusted for *minimum* output. To keep the receiver tuned to the signal frequency, it is desirable to readjust the tuning control of the receiver frequently as the neutralization progresses. This is required because there is some reaction between the tuning and the neutralizing adjustments. Having adjusted C4, the tube is replaced and the dummy tube inserted in the third r-f. socket. In the same way C3 is adjusted for minimum output. Similarly the dummy tube is in turn inserted in the second and first r-f. sockets and C2 and C1, respectively, are adjusted. It is to be understood that a modulated signal is being used throughout the above procedure and that the volume control is at maximum.

The frequency at which the receiver is to be neutralized will depend upon the design, and "Rider's Manuals" should be consulted for available data. In general, a frequency in the neighborhood of 1000 kc. is satisfactory and provides adequate neutralization throughout the band. If the receiver, when neutralized at 1000 kc., shows a tendency to oscillate at the high-frequency end of the band, then neutralization should be carried out at a higher frequency, say about 1200 kc. On the other hand, if the receiver is stable at the high-frequency end but oscillates at about 600 kc., the low-frequency end, then the receiver should be neutralized at about 800 kc. In every case it is important to check the stability of the receiver throughout the entire band.

If the receiver uses tube shields, it is important that they be in place during neutralization. Repetition of the entire procedure is advisable in those cases where an appreciable change in the neutralizing condensers is made. Having completed the neutralization, the receiver can now be aligned in accordance with the instructions given in a preceding section. Should the receiver show a tendency toward instability after alignment, the neutralizing adjustments should be repeated. It should be pointed out that neutralization is effective only insofar as instability and oscillation are caused by feedback through the grid-plate capacity of the tube. *If the feedback is due to other causes, such as inadequate shielding, improper voltages, or open bypass condensers, it will be impossible to neutralize the receiver properly before these defects are corrected.*

Chapter IV

THE ALIGNMENT OF SUPERHETERODYNE RECEIVERS

A THOROUGH understanding of the basic principles underlying the superheterodyne is indispensable if alignment is to be carried out intelligently and efficiently. For this reason we digress at this point to offer a brief explanation of the operation of superheterodyne receivers. The limited space available makes it impossible for us to go into great detail. For a complete treatment of the subject we refer you to "Servicing Superheterodynes" by Rider.

Fig. 30 will help to explain the general principles involved in the alignment of the superheterodyne.

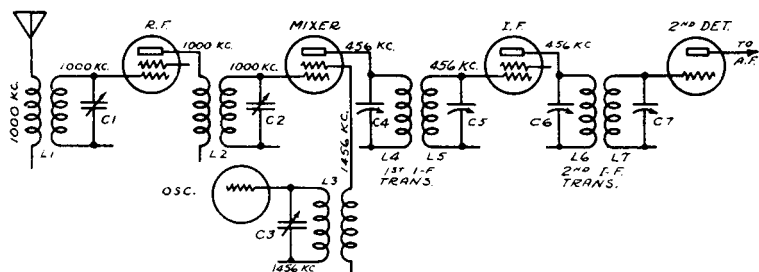

Fig. 30. A fundamental superheterodyne circuit. The frequencies at which the signals pass through the components are designated.

An input signal frequency of 1000 kc. is assumed and, beginning at the antenna, we will trace the progress of the signal through the tuned circuits subject to alignment. The function of the first radio-frequency stage is to amplify the signal; consequently, the first tuned circuit L_1C_1 is tuned to 1000 kc. After

amplification, the 1000-kc. signal emerges in the plate circuit of the first r-f. stage and is impressed on the grid of the first detector tube via L_2C_2 , which is tuned to 1000 kc. This tube is commonly known by several different names: first detector, modulator, frequency converter, translator and mixer. It is the tube in which the signal frequency is converted into the intermediate frequency.

The function of the oscillator is to generate a voltage which differs in frequency from the signal being received by an amount equal to the intermediate frequency. In this case, the intermediate frequency is assumed to be 456 kc., so that the oscillator frequency is 1456 kc. That is, the circuit L_3C_3 is tuned so that the oscillator generates a 1456-kc. voltage, when the r-f. and mixer circuits are tuned to 1000 kc. This local oscillator voltage is impressed on the modulating grid of the first detector, and, as a result of the rectification which takes place in the first detector, a frequency equal to the *difference* between the signal and the oscillator frequencies appears in the plate circuit of the first detector.

In order that the maximum signal voltage at the difference frequency—the intermediate frequency—appear in the plate circuit of the first detector, the tuned plate circuit is resonated at 456 kc. This is L_4C_4 . It is important to realize that the 1000-kc. modulated signal, which was impressed on the antenna, has now been converted into a 456-kc. signal, which contains exactly the same modulation as the original 1000-kc. signal. We are now interested in amplifying the 456-kc. signal and, therefore, the first i-f. transformer, comprising L_4C_4 and L_5C_5 , is tuned to the intermediate frequency, 456 kc. Succeeding i-f. stages are also tuned to 456 kc. The greatly amplified 456-kc. voltage is now impressed on the second detector grid. Demodulation, rectification, or detection, whichever you want to call it, takes place and the resultant audio voltage appears in the plate circuit of the second detector. It is important to understand that the audio voltage, which appears in the plate circuit of the second detector, is exactly the same as the audio voltage which would have been obtained if the original 1000-kc. signal were passed through a 1000-kc. amplifier and detected, as in the conventional TRF receiver.

General Intermediate-Frequency Amplifier Alignment

Prior to the popularization of the cathode-ray oscillograph and visual forms of alignment, there was but one method of aligning a radio receiver. This was the use of a signal generator and an output meter. In this discussion of i-f. amplifier alignment, we are going to deal with the older method, namely the use of a signal generator and the output indicator. The visual form of alignment, utilizing the frequency-modulated oscillator and the cathode-ray oscillograph, will be dealt with later in this volume.

The first step in the alignment of any superheterodyne is the alignment of the intermediate-frequency amplifier. Regardless of the type of superheterodyne, or the frequency range covered, the intermediate-frequency transformers are adjusted independently of any tuned circuits in any other part of the receiver. *Under no circumstances should the intermediate-frequency alignment be made secondary to the r-f. or oscillator adjustment.* We shall use the circuit in Fig. 30 as a model in describing the procedure to be followed in i-f. alignment.

To prevent harmonics of the signal generator from feeding into the r-f. amplifier and causing miscellaneous beats, it is desirable to short the oscillator section of the variable condenser. This is a general method in that it is equally applicable when a separate oscillator tube or when a combination oscillator-modulator is used. A short clip lead is convenient for this purpose. If the receiver incorporates a selectivity control, it is important that this control be placed in the *maximum* selectivity position.

While aligning the i-f. amplifier, it is good practice to have the wave-band switch in the *broadcast-band* position. With the switch in the short-wave range position, it may not be possible to get enough voltage from the signal generator to drive a signal through the i-f. amplifier when the stages are badly out of line. This is so because the coil in the receiver detector grid circuit acts as a virtual short circuit across the signal generator output when the receiver wave-band selector switch is set on one of the high-frequency ranges. If, when this precaution has been observed, it is impossible to get a reading on the output meter, connect the signal generator to the grid of the last i-f. tube, instead of to the

first detector grid. If you find that this change is necessary, adjust the last i-f. transformer for maximum output. Use the attenuator on the signal generator to cut down the signal input, as the stage is brought into resonance.

If you feed the signal through the mixer, connect the signal generator to the mixer grid through a shielded lead, as shown in Fig. 31. Note that the grid lead is connected to the grid of the

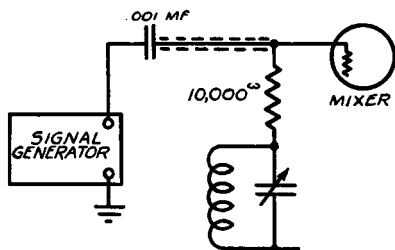

Fig. 31. When the signal generator is fed to the mixer tube, it should be connected through a .001-mf. condenser and a 10,000-ohm resistor, as is shown on the left.

first detector through a 10,000-ohm resistor. It is convenient to fit this resistor, which may be a small one-third watt unit, with a grid cap connector at one end and the grid post from the top of an old tube at the other end. The grid lead is then removed and replaced by the special coupling resistor; the grid lead should not be left free, but should be connected to the other end of the resistor. This coupling resistor unit should be as small as possible, so that it does not interfere with the tube shield, which must be in place during alignment. In every case, the final alignment should be made with the signal generator connected to the first detector and all the trimmer adjustments repeated because of possible interaction between the circuits. As shown in Fig. 31, the output from the signal generator is taken through a .001-mfd. condenser. This condenser is used to avoid disturbing the voltage constants of the mixer by the grounding of the grid through the signal generator attenuator network.

Aligning Atwater Kent Receivers

The i-f. alignment of a great many Atwater Kent superheterodynes requires that several special balancing units be used, because the primary and secondary of the transformers in these models are overcoupled to obtain a broader frequency band-pass.

Improper alignment may result if the regular procedure is followed. The necessary units, which are shown in Fig. 32, are very easily constructed. Two of the type "A" units are required. The type "B" units are used on earlier models.

The alignment procedure is as follows: Couple the signal generator to the first detector through the detector coupling unit described in a preceding paragraph.

Fig. 32. The value of R for the type "A" unit is 40,000 ohms and R for type "B" is 20,000 ohms. The latter type is employed in earlier models.

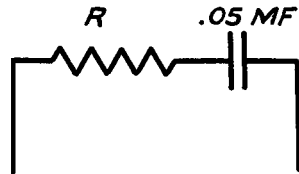

Place the balancing unit across the primary of the last i-f. transformer and peak the secondary for maximum output. Remove the balancing unit and place it across the secondary winding of the same transformer. Adjust the primary trimmer for maximum output. In the same manner, adjust the remaining i-f. transformers for maximum output. In case of instability while peaking the trimmers of the last i-f. transformer, place an extra balancing unit across the secondary winding of the next to the last i-f. transformer. Repeat the alignment operation in order to check the trimmer adjustments. When the last trimmer has been peaked, remove the balancing unit and seal the trimmers.

Balancing Unit for General Use

The use of a balancing unit of this type is not limited to Atwater Kent receivers. It is useful when an i-f. transformer, which has closely coupled windings, is being aligned. Of course, in all these cases the visual method of alignment is by far superior to other methods, both from the viewpoint of the great accuracy achieved and the saving in time.

However, where the cathode-ray equipment is not available, we suggest the following method of procedure: The i-f. signal is fed into the first detector in the usual manner. Alignment of the last i-f. transformer is the first operation. A .01-mf. condenser in series with a 10,000 ohm resistor is shunted from the grid terminal of the second detector to ground. If a diode detector is used, the balancing unit is shunted from the diode anode to ground. The damping action of this unit on the secondary tuned circuit

of the transformer now makes it possible to peak the primary circuit at the i-f. frequency. It will be necessary to increase the signal generator output in order to get a readable deflection on the output indicator. After the primary is aligned, the balancing unit is removed and the secondary trimmer adjusted for maximum output. It is not necessary to shunt the primary winding while peaking the secondary trimmer. The same procedure is carried out for the remaining i-f. transformers. In each case the balancing unit is connected across the respective secondaries. This method is convenient in that it is unnecessary to make any connection underneath the chassis since the balancing unit is shunted from the grid terminal to ground.

Aligning Overcoupled I-F. Transformers with Output Meter

If you recall, we stated that overcoupled i-f. transformers had two peaks. Alignment of such systems or such transformers with an output meter is not the simplest matter, but the occasion does arise when such operations are required, consequently the following should be of some value: As a rule, these transformers, when overcoupled, are arranged to have a band-pass of about 7 to 8 kc. each side of the peak frequency. Therefore, when aligning, the minimum indication will be obtained at the peak frequency and two maximum indications will be obtained—one each side of the peak frequency. If the band-pass is 7 kc. each side of the rated i-f. peak, which we will assume to be 260 kc., then a maximum indication will be obtained at 253 kc. and another maximum will be found at 267 kc. When adjusting such a transformer, the signal generator should be tuned through this band. It might not be a bad idea to tune the signal generator through a band of at least 10 kc. each side of the rated peak and to adjust the unit so that the meter indication is the same for both peaks. By this we mean that the amplitude of the peaks should be the same. This is not done as easily as it sounds and is a tedious operation. However, since it is essential—it must be done. When adjusting such overcoupled transformers, it is essential that the fidelity or selectivity control be in the “maximum fidelity” position.

Neutralization of I-F. Amplifiers

The procedure in neutralizing i-f. amplifiers is similar to that described in connection with the neutralization of TRF receivers. A dummy tube of the same type as that used in the i-f. stages is required. One heater or filament prong must be cut off so that the tube will not be active. Neutralization is, of course, carried out at the intermediate frequency. The signal generator is fed into the first detector in the normal manner, and the i-f. amplifier is aligned as usual. After alignment has been completed, the receiver is neutralized. The tube in the stage being neutralized is removed and replaced with the dummy tube. The signal generator output is increased until a reading is obtained on the output indicator. The neutralizing trimmer associated with the stage is now adjusted for *minimum* output. The same procedure is repeated for the remaining stages. It is advisable to repeat the alignment, as there is some reaction between the alignment adjustments and the neutralizing adjustments. The i-f. amplifier is now neutralized and aligned.

Regenerative I-F. Amplifiers

The alignment of i-f. amplifiers, which incorporate regeneration to increase sensitivity and selectivity, requires special attention. As an example of the procedure to be followed in such cases, we will refer to the alignment of the Atwater Kent 944, which is shown in Fig. 33.

The signal generator is connected to the first detector, preferably through the coupling resistor previously described. A sensitive output indicator must be used, because the final alignment must be made with a weak signal. The regeneration control condenser A5, which controls the amount of feedback, should be set near minimum capacity and the i-f. trimmers, A-3 and A-4, peaked for maximum output. As the set is brought into alignment, the signal generator output should be decreased, so as to use the smallest signal strength consistent with a readable deflection. The regeneration control should now be advanced, i.e., the trimmer A-5 is turned clockwise until a squeal is heard, indicating oscillation. The trimmer is then backed off until the audio squeal just disappears. With the regeneration control in this position, the i-f. trimmers, A-3 and A-4, are again peaked for maximum output.

The important things to note in the above procedure are that the final adjustment of the i-f. trimmers is made with a very weak signal and with the amplifier fairly close to the edge of oscillation.

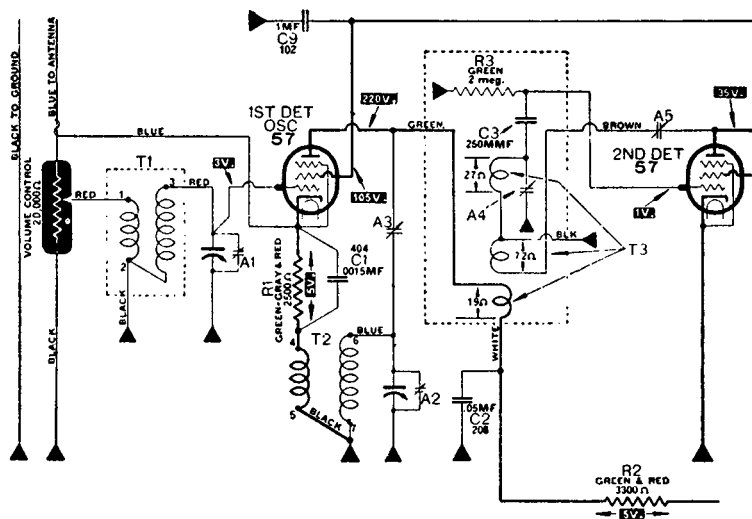

Courtesy Atwater Kent Mfg. Co.

Fig. 33. Regeneration, which is introduced to increase sensitivity and selectivity, is controlled by condenser A-5. Condensers A-3 and A-4 are the i-f. trimmers.

The information given herein concerning Atwater Kent receivers is, in general, applicable to all other superheterodyne receivers wherein regeneration is employed in the i-f. amplifier. You will find upon examination of circuits of such receivers as shown in "Rider's Manuals," that the manner of adjustment as herein described is applicable.

Staggering

A method much in vogue for broadening the frequency band-pass of i-f. amplifiers is that of staggering or detuning the i-f. transformers about the peak frequency. This method of broadening the i-f. amplifier is to be recommended only where the set has more than ample sensitivity and the high-frequency response

is poor because of excessive selectivity in the i-f. amplifier. Also when proper alignment, as specified by the receiver manufacturer, requires that the transformers be staggered.

It may sometimes happen that a receiver may show symptoms of excessive selectivity as a result of regeneration. If this appears to be the case, it is essential to eliminate the regeneration before aligning. When you are satisfied that regeneration is not responsible for the excessive selectivity, then the condition can be remedied by staggering properly. We recommend strongly that a visual method of alignment with cathode-ray equipment be used to accomplish the broadening of the selectivity response, but if the equipment is not at hand, the procedure is as follows: The i-f. amplifier is aligned in the usual manner for maximum selectivity. Where the i-f. amplifier incorporates but two i-f. transformers, staggering should, in general, be unnecessary. However, if staggering is desired, when two transformers are used, set the signal generator to a frequency which is about 3 kc. *higher* than the i-f. peak. Now peak the first i-f. transformer so

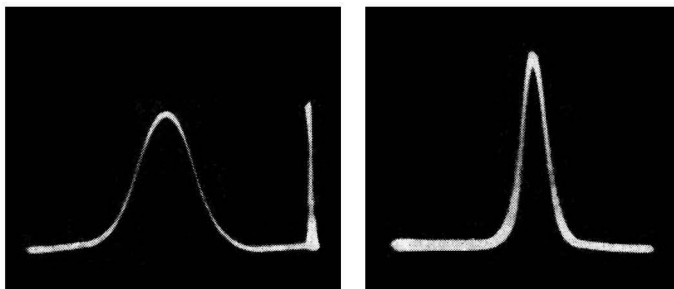

Figs. 34A, left, and 34B. The left oscillogram is the resonance curve of a staggered i-f. amplifier. Note the band-width and amplitude and compare with the curve of Fig. 34B, which resulted when the transformers were peaked at the same frequency for maximum sensitivity and selectivity.

as to get maximum output, leaving the second transformer untouched. Set the signal generator to a frequency which is *lower* than the i-f. peak in the receiver by 3 kc. and peak the second transformer for maximum output at this frequency.

What you have done so far is to peak the first i-f. transformer 3 kc. higher than the i-f. peak, and the second transformer 3 kc.

lower than the i-f. peak. The overall response should now be checked by slowly varying the frequency of the signal generator over a band of frequencies of about 10 kc. each side of the rated peak frequency of the i-f. amplifier. The type of resonance curve created by such staggering is similar to that shown in Fig. 34A. This curve is similar to the single-peak curve for optimum coupling of a two-winding transformer, such as is shown in Fig. 13D. A comparison of the effect of staggering upon band width and amplitude can be made by comparing Fig. 34A with Fig. 34B, which shows the resonance curve for the system when both transformers are peaked at the same frequency for maximum selectivity and amplitude.

Generally speaking, the need for staggering occurs when there are three i-f. transformers of the sharply tuned variety. In this case it will be sufficient to stagger the last two i-f. transformers by the method just outlined and to peak the first i-f. transformer at the rated frequency.

As a final precaution, we wish to emphasize that the need for the staggering process just described seldom occurs in practice. Staggering is fine—up to a certain point, but in many cases the limitations imposed in the form of reduced sensitivity are serious handicaps. The reduction in amplitude, which in a sense means sensitivity, is evident in Figs. 34A and 34B. A further important item is that the staggering adjustment made it essentially a fixed one and cannot be changed at the convenience of the operator to suit noise conditions and adjacent channel interference. This consideration alone places a distinct limit upon the amount of staggering which can be tolerated. The 3-kc. staggering, previously mentioned, is a reasonable limit. If the staggered peaks are further apart, there will be a gradual approach to a resonance curve which has two distinct peaks, such as would occur in the over-coupled transformer and there is a very wide band pass, which would naturally result in reduced selectivity. Accompanying this reduction in selectivity is a very marked decrease in sensitivity; so much so that it is not practical to attempt to develop a double peak resonance curve by staggering the transformer peaks.

It might be well at this time if we again refer to Fig. 34A and state that when normal staggering of the i-f. peaks is employed,

the final peak of the i-f. amplifier as a unit occurs at the original rated peak frequency. In other words, if, in a system which is peaked normally at 260 kc., one transformer is staggered and peaked at 257 kc. and the other transformer is peaked at 263 kc., the resultant resonance curve will show broad response at the top of the curve but there will still be a peak at the mean of these two frequencies, or 260 kc. If the two transformers are peaked at widely different frequencies, a resonance curve similar to that shown in Fig. 13-I will result, with a very great reduction in amplitude. Instead of a peak at the mean frequency, there is a very definite dip. Such operation is, of course, out of the question.

Dual Band Receivers with a Single Oscillator Range

There are two systems for providing dual band coverage, without switching in the oscillator circuit, in use in the current production of the smaller receivers in which simplicity and economy of parts are important factors. The essential characteristic of this type of receiver is that the oscillator covers but a single band of fundamental frequencies, while the tuned detector circuit incorporates a two-position switch for the two bands.

We shall first discuss that type of receiver in which use is made of the second harmonic of the oscillator's fundamental range to provide the heterodyning frequency for the short-wave band. The RCA Model T 5-2 is an example of this type of receiver. The range covered on the upper band is from 1600 kc. to 3500 kc. and this is obtained by using the second harmonic of the oscillator's fundamental range, which is from 1000 kc. to 2180 kc. In other words, on the upper band the range of oscillator frequencies is *twice that of the range on the broadcast band*, or from 2000 kc. to 4360 kc.

In contrast to the method of operation just described, the Stewart-Warner R-142A chassis is representative of receivers, which have a circuit layout similar to that described above, but which do not use harmonics. Instead on the second band the oscillator frequency is *below the signal frequency rather than above* (as it is on the broadcast band) and in this manner the frequency range of the receiver is extended without any switching in the oscillator circuit. It may be noted that the second method does not provide as wide a frequency range as does the first method which employs harmonics.

Alignment of these receivers is in keeping with the simplicity of the circuit and no adjustments are required for the short-wave range. That is, if the receiver is aligned for the broadcast band it will be in alignment for the short-wave band.

Chapter V

OSCILLATOR ALIGNMENT

As PREVIOUSLY stated, the function of the oscillator is to generate a signal which differs in frequency from the signal received by an amount equal to the i-f. peak. This oscillator signal is mixed with the received signal and as a result of the operation of the mixer or first detector, the i-f. signal is developed. A far more elaborate explanation of the function of the oscillator will be found in Rider's "Servicing Superheterodynes."

Since we are concerned with alignment, let us see why alignment of the oscillator system in a superheterodyne is an important function.

Let us start with the premise, which happens to be an actual fact in all normally operating receivers, that the only frequency which can get through the i-f. amplifier is the intermediate frequency. We shall assume that, for the sake of illustration, this frequency is 450 kc. Let us further assume that the receiver is tuned so as to receive a signal of 10,450 kc. According to what has been said, namely, that the oscillator frequency is the difference between the received signal frequency and the intermediate frequency, the required oscillator frequency would then be $10,450 + 450$, equal to 10,900 kc., or $10,450 - 450$, equal to 10,000 kc. It is evident that there are two oscillator frequencies or heterodyning frequencies, which can beat with the incoming signal and produce the required intermediate frequency. However, it is customary in modern radio receiver design to adjust the oscillator tracking so that it is always *higher* than the received signal frequency by the value of the intermediate frequency. Consequently, the proper frequency for this oscillator, in order to receive the 10,450 kc. signal, would be 10,900 kc.

In accordance with what has been said, it is also evident that if some other signal, which was greater than the oscillator frequency by 450 kc., would find its way into the mixer tube, it also would result in an intermediate-frequency signal of 450 kc. In other words, with the oscillator generating a 10,900-kc. signal, it is possible to receive a 10,450-kc. signal and also an 11,350-kc. signal, when the intermediate-frequency amplifier is peaked at 450 kc. Incidentally, that interfering signal, which can be received when the oscillator is operating properly and heterodyning the required signal, is known as the *image* signal. In the example cited, the 11,350-kc. interfering signal is the *image* for the 10,450-kc. signal. It is the function of the radio-frequency and mixer tuned circuits to reject the image signal and all other interfering signals. Image frequency elimination is discussed later.

As stated, it is up to the r-f. selectivity to determine whether one, both, or no signals, capable of beating with the oscillator to form the intermediate frequency, will reach the second detector with sufficient strength to cause an audible signal. As a general rule, the receivers are so constructed that only one signal will get through—that which is lower than the oscillator frequency—in this case the 10,450-kc. signal. The possible passage of other signals as a result of harmonic relation is beyond the scope of this book, but is discussed in detail in Rider's "Servicing Superheterodynes." At the same time, however, we might take this occasion to mention that since a certain condition is desired in the receiver, the matter of oscillator alignment becomes one of importance in the effort to make certain that the oscillator frequency is higher than the received signal frequency by the correct amount.

Oscillator Tracking

In the previous paragraph we stated that the oscillator frequency is higher than the received signal frequency by an amount equal to the intermediate frequency. This condition is true for every setting of the dial. For example, in a receiver with an intermediate frequency of 450 kc. and tuned to receive a 600-kc. signal, the oscillator frequency is 1050 kc. In the middle of the band, when tuned to receive a 1000-kc. signal, the oscillator frequency is 1450 kc. At the end of the band, when tuned to receive a 1500-kc. signal, the oscillator frequency is 1950 kc. *This maintenance of the oscillator frequency, so that it is constantly higher*

than the signal being received by a predetermined amount, is referred to as oscillator tracking.

It might be well at this time to make mention that while the above is true in practically all cases, there may be one or two exceptions wherein the harmonic of the fundamental oscillator frequency is used to heterodyne a short-wave signal. In other words, the second harmonic of the 1950 kc. signal generated by the oscillator, which is equal to 3900 kc., would be used to beat against or mix with a 3450-kc. incoming signal, so as to generate the required 450-kc. intermediate frequency. It might also be well to state that in those cases where the oscillator frequency is maintained higher than the received signal by a constant amount, that difference exists over the entire band, inclusive of the short-wave bands.

There are two methods in common use for accomplishing oscillator tracking as previously described. The first method makes use of a special oscillator tracking section of the ganged condenser, wherein the shape of the plates is so designed that the required variation of the oscillator frequency is maintained. This method requires no further comment in that the alignment of the oscillator is automatically taken care of and can only be changed by bending the end plates of the oscillator condenser section. This statement assumes that these plates are cut for the purpose.

The second and more widely used method for making the oscillator track, is through the use of two condensers, the "padder" at the low-frequency end of the band and the "trimmer" at the high-frequency end. These terms, when applied to an oscillator system, indicate the function of the tracking condensers. Basically, every oscillator used in receivers incorporates a tuned circuit by means of which the frequency of oscillation is controlled. Referring to a typical oscillator schematic in Fig. 35-A, we shall first discuss the operation of the *shunt trimmer*. This trimmer, C2, provides the oscillator tracking adjustment over the high-frequency end of the band. At this end, the variable tuning condenser C1 is completely unmeshed and the capacity in the tuned circuit is largely made up of the trimmer capacity C2. It is for this reason that C2 is called the *high-frequency oscillator trimmer* and exercises a critical control over the oscillator frequency at the high-frequency end of the band. At the low-frequency end, however, C1 is completely meshed and, its capacity being about 350 mmf., the capacity of the trimmer condenser C2 has

relatively little effect in changing the total capacity in the circuit and hence in changing the frequency.

Fig. 35A. In this typical oscillator circuit, condenser *C2* is the oscillator trimmer and condenser *C3* is the oscillator padder. Condenser *C2* provides the oscillator tracking adjustment over the high-frequency end of the band and *C3* over the low-frequency end.

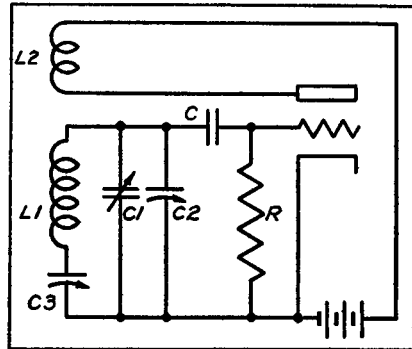

In the case of the low-frequency series tracking condenser, called the oscillator padding condenser, conditions are different. At the high-frequency end of the band, the capacity of this condenser is sufficiently great so that it acts as a bypass condenser. For this reason, $C3$ has little control over the frequency at this end; in fact, if it were removed from the circuit, the frequency would remain about the same. However, as the frequency is decreased, the capacity of the tuning condenser becomes comparable to that of the padder and, therefore, $C3$ has greater control over the frequency of oscillation.

So much for the theory underlying the tracking of the oscillator system with the balance of the receiver, and the function of the "padder" and "trimmer." In view of the fact that the alignment operations or tracking operations in the oscillator system are very closely tied in with alignment of the r-f. and particularly the mixer or first detector systems, we feel that it would be best to discuss the mechanical operations of oscillator alignment in connection with r-f. and detector alignment. Accordingly the process of oscillator alignment is discussed in the next chapter.

Chapter VI

R-F. AND DETECTOR ALIGNMENT

WE HAVE already considered the alignment of i-f. amplifier circuits. The next step in the alignment process is the adjustment of the radio-frequency portion of the receiver, consisting of the detector and the r-f. tuned circuits and the alignment of the oscillator.

Dummy Antenna

A dummy antenna is recommended for proper alignment of the input circuits. The standard dummy antenna, which has been adopted by the I.R.E., has the following characteristics: $C = 200$ mmf., $L = 20$ microhenrys, and $R = 25$ ohms. In the case of the signal generators of the type used for service work, their output impedance is unknown, and furthermore, it varies widely with the setting of the attenuator. For this reason nothing is gained by using the standard antenna, unless it is used in conjunction with a precision signal generator of known output impedance characteristics.

For general use with the average service signal generator, we recommend that the unit shown in Fig. 27 be used as the dummy antenna. It will operate satisfactorily over the short-wave and broadcast bands.

R-F. and First Detector Alignment

Inasmuch as the alignment of the r-f. end of the receiver is tied in with the alignment of the oscillator, it will simplify the explanation to go over the complete oscillator and r-f. alignment procedure for a typical receiver circuit. These parts of a typical receiver are shown in Fig. 35-B. The trimmers which are discussed, appear in the schematic.

The first step is to connect up the signal generator and output

indicator; the former through the dummy antenna, shown in Fig. 27. We shall assume that the alignment is for the broadcast band and that the two alignment frequencies are 1400 kc. and 600 kc., the former being the adjustment at the high-frequency end of the band and the latter at the low-frequency end.

Having checked the position of the dial according to the reference line (see Tuned R-F. Alignment) to insure that it is correctly located on the condenser shaft, both signal generator and

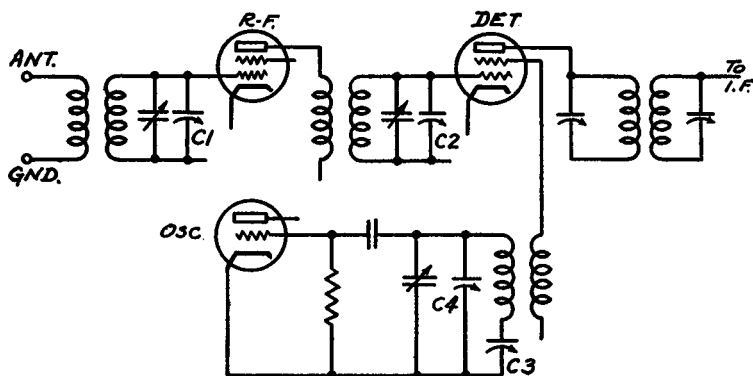

Fig. 35B. In this typical superheterodyne circuit, *C1* is the r-f. trimmer, *C2* is the detector trimmer, *C3*, the oscillator series padder and *C4* the oscillator shunt trimmer. Their respective adjustments are explained in the accompanying text.

receiver are tuned to the high-frequency calibration point, 1400 kc. The *oscillator shunt trimmer*, *C4*, is adjusted for maximum output. Without disturbing the position of the tuning condenser or the setting of the signal generator, the detector trimmer, *C2*, is adjusted for maximum output. In the same way, the r-f. trimmer, *C1*, is also adjusted for maximum output. ***We repeat—these three trimmers are adjusted for maximum output without disturbing the setting of the signal generator or the tuning control of the receiver.*** If the output indication increases appreciably, the output of the signal generator should be cut down so as to keep the setting upon the indicator at about middle scale. This completes the r-f. and detector adjustments at the high-frequency end of the band. The next step is alignment of the oscillator at the low-frequency end of the broadcast band.

Low-Frequency Oscillator Alignment

Set the signal generator at 600 kc., and tune the receiver to the neighborhood of 600 kc. Do not tune the receiver to exactly 600 kc., but rather to that point in the vicinity which *gives the maximum output*. This setting will not, as a rule, coincide with 600 kc. on the dial. The low-frequency adjustment is then effected by alternately readjusting the trimmer, C3, and the tuning condenser for maximum output. This operation is commonly known as *rocking*. It consists simply in finding that combination of oscillator trimmer adjustment and tuning condenser position which gives the maximum output. This adjustment is final, regardless of whether the dial reads exactly 600 kc. or slightly off 600 kc.

The following will explain why this rocking process is necessary: In aligning the receiver at the low-frequency end, only one adjustment is generally provided, namely, the series oscillator padder. There is no trimmer adjustment to bring the detector and r-f. tuned circuits into resonance. Remembering that the greater part of the selectivity and sensitivity of a superheterodyne is in the i-f. amplifier, it will be evident that the setting of the tuning condenser is determined largely by the fact that the oscillator frequency must be higher than the signal frequency by an amount equal to the i-f. frequency. To take a numerical example, (i-f. peak equal to 450 kc.), it may happen that maximum output is obtained with the oscillator tuned to 1055 kc. and the first detector and r-f. circuits tuned to 590 kc. instead of to 600 kc., the signal frequency. By rocking the condenser shaft, a new setting can be found which tunes the r-f. circuits to exactly 600 kc. and the oscillator to 1050 kc. The latter combination, of course, will give better selectivity and sensitivity.

In view of the fact that a certain amount of interaction exists between the adjustments at the low-frequency end of the band and those at the high-frequency end, it is advisable to repeat all the adjustments at the high-frequency end, that is, to re-peak the trimmers C3, C2 and C1, after having made the 600-kc. adjustment.

If the receiver is a multi-band job, then the general alignment procedure for each band follows along the same lines as that just described. However, there are some modifications in the procedure and these differences will be taken up in due order. One of the differences is that in some modern multi-band receivers, the alignment frequencies on the broadcast band are 580 kc. and between 1600 kc. and 1700 kc.

Rocking Necessary for High-Frequency Detector Alignment

One of the essential differences in alignment of the first detector at the high frequencies and over the broadcast band is that there is an interaction between the oscillator and detector tuned circuits at the high frequencies. This interaction between the oscillator and detector circuits, especially prominent when the pentagrid converter is used, leads to an interlocking action between the detector and oscillator trimmer adjustments. Peaking the detector trimmer after the oscillator trimmer has been adjusted for maximum output at the calibration frequency, changes the oscillator frequency and impairs overall performance. The remedy is to find that combination of oscillator and detector trimmer adjustment, which tunes the detector circuit to resonance with the incoming signal, and at the same time provides an oscillator frequency, which is higher than the received signal frequency by an amount equal to the intermediate frequency. This is accomplished by continuously shifting or rocking the tuning condenser backward and forward through the peak and simultaneously adjusting the detector circuit for maximum output.

If considerable interaction exists between the two circuits, it will be found that the optimum adjustment has appreciably disturbed the calibration. To remedy this, adjust the oscillator trimmer for maximum output on calibration and repeat the rocking process. It will be found that this will bring the set more nearly into correct calibration. Generally it will be unnecessary to repeat the rocking process, as the amount of interaction is not as a rule sufficient to disturb the calibration seriously. *It is not necessary to rock the condenser gang while aligning the r-f. stage.*

Insufficient Attenuation at Higher Frequencies

It may happen that when aligning a sensitive receiver at the higher frequencies, it is impossible to attenuate the signal input sufficiently to work below the AVC level. In these cases the signal generator is not connected to the receiver but is placed some distance from it. A 400-ohm carbon resistor is shunted from the antenna post of the receiver to ground, and a short piece of wire is connected to the antenna post and is used as a pick-up lead. The signal generator and receiver, of course, should be grounded to prevent body capacity effects.

R-F. Compensating Condenser Adjustment

Some of the early superheterodyne receivers were equipped with an r-f. compensating condenser. The adjustment is generally made near the low-frequency end of the band. The trimmer is rotated until the receiver goes into oscillation and it is then backed off until the oscillation or squeal stops. It is important that the receiver be checked for stability throughout the band. Use a fairly strong signal input.

I-F. Wave Trap Adjustment

The function of the i-f. wave trap is to prevent interfering signals at the intermediate frequency from reaching the i-f. amplifier. The wave trap generally takes the form of a tuned circuit resonated to the intermediate frequency. Two common types are shown herewith. Fig. 36A illustrates the parallel resonant circuit tuned to the intermediate frequency and Fig. 36B

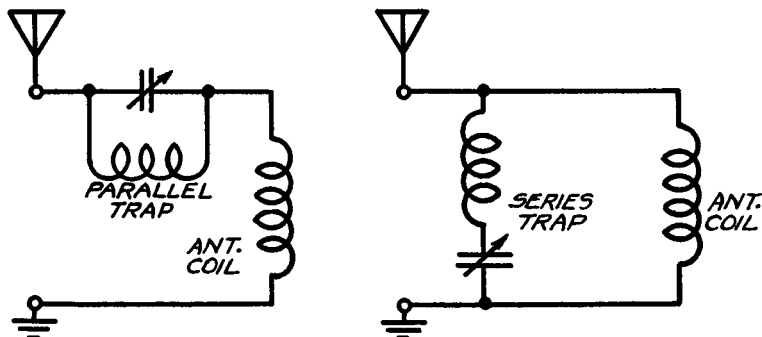

Figs. 36A, left, and 36B. Either type of trap circuit, when resonated to the intermediate frequency, prevents signals at that frequency from entering the i-f. amplifier.

shows the series resonant circuit tuned to the intermediate frequency. In each case the procedure is to align the i-f. amplifier and the oscillator circuits in the usual manner. Before aligning the r-f. circuits, the signal generator is connected to the antenna and ground posts of the receiver and set at the intermediate frequency. The trap trimmer is adjusted for *minimum* output on the indicator. The output of the signal generator is advanced to maximum so that the trimmer can be set accurately. While the trimmer is being adjusted, the receiver is preferably tuned to

the low-frequency end of the broadcast band, about 550 kc., as this setting is most susceptible to interference at the intermediate frequency.

After the trimmer has been adjusted for minimum output, the r-f. circuits are peaked in the usual manner. This procedure is suggested because of possible interaction between the r-f. circuit alignment and the wave trap. *It is highly important that the signal generator and output lead be carefully shielded to prevent stray coupling directly into the i-f. amplifier.*

Image Suppression Circuits

In the early Atwater Kent superheterodynes, particularly in the 70, 72, 74 and 76 series, where no r-f. amplification is employed, a special circuit is used for image rejection. The circuit

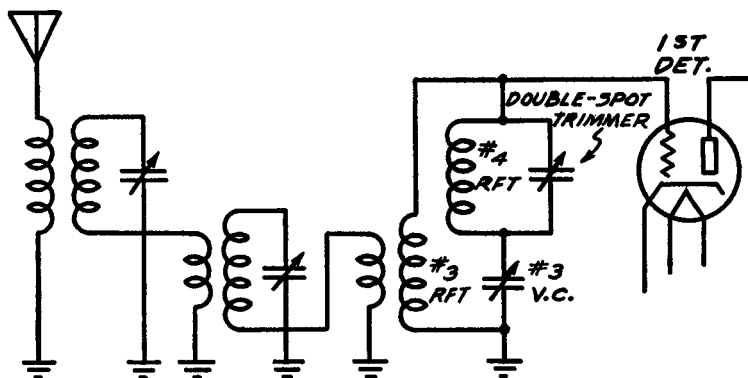

Fig. 37. The image suppression circuit, No. 4, is maintained at a frequency that is higher than the receiver dial setting by twice the value of the intermediate frequency. This circuit is adjusted by the double-spot trimmer.

of this *double spot* system, as it is called, is shown in Fig. 37. The alignment of the image rejection circuit, which effectively acts as a short circuit between grid and ground of the first detector at the image frequency, requires that a special procedure be followed. This is outlined in the following paragraph.

The signal generator is connected to the antenna and ground posts of the receiver. With the receiver tuned to 1500 kc. and the signal generator adjusted to this frequency and with normal output the r-f. preselector

trimmers are peaked for maximum receiver output. The receiver is now tuned to 1240 kc. *The frequency of the signal generator is not changed.* With the signal generator set at 1500 kc. and for maximum output, the receiver is carefully tuned in the neighborhood of 1240 kc. The double spot trimmer is now adjusted for *minimum* receiver output. It may not be possible to eliminate the image response completely. This will depend upon the strength of the 1500-kc. signal available. At any rate, the double spot trimmer is adjusted for *minimum* receiver output. The receiver should now be retuned to 1500 kc., the signal generator output decreased to normal, and trimmer No. 3 readjusted for maximum receiver output. The receiver is tuned to 1240 kc. again and the adjustment of the double spot trimmer for minimum receiver output repeated. This procedure should be repeated until further adjustment of trimmer No. 3 does not increase the output of the receiver and further adjustment of the double-spot trimmer does not reduce the output of the receiver at 1240 kc. to a greater extent.

There are in use some continuously tuned image suppression circuits. The function of these circuits is to minimize image interference by preventing the passage of the image signal to the first detector. Consequently, the image suppression circuit is tracked with the other tuned circuits in the receiver and is always maintained at a frequency adjustment which is higher than the receiver dial setting by twice the intermediate frequency. Consequently, when such image suppression circuits are to be adjusted for a given dial setting of the receiver, the signal generator must be tuned to a frequency higher than the dial reading by an amount equal to twice the intermediate frequency and the circuit is aligned for minimum response.

For example, to adjust such a circuit in a receiver, which has an i-f. peak of 175 kc., the receiver is tuned to, say, 1200 kc., and the signal generator is tuned to the image frequency, which is 1550 kc. The image circuit trimmer is now adjusted for *minimum* output, since we desire to eliminate this image signal. It is important to remember that since the image suppression circuits are generally tied in with the other tuned circuits, the adjustment of the image suppression circuits must be followed by realignment of the r-f. circuits, as in the case of the Atwater Kent double-spot system.

In receivers which employ an oscillator frequency *higher* than the signal frequency, the image frequency is equal to the signal frequency *plus* twice the intermediate frequency. In receivers which employ an oscillator frequency *lower* than the signal frequency, the image frequency is equal to the signal frequency *minus* twice the intermediate frequency.

Double Conversion Systems

A number of receivers have been manufactured in which the superheterodyne principle is employed twice in succession. Receivers, which employ this principle in a single unit, are known as double superheterodynes, of which the Stewart Warner 105 series is an example. In addition, any superheterodyne such as one originally intended for use on the broadcast band, and which is used in conjunction with a short-wave converter for short wave reception, is another example of a double superheterodyne or a double conversion system. The primary difference between these two types of double conversion systems is that the former is a single unit embracing all of the elements, whereas the latter consists of two distinct units, namely, the converter as one and the receiver as the other.

The block diagram in Fig. 38 is an example of the general layout in such a double conversion receiver. To illustrate the opera-

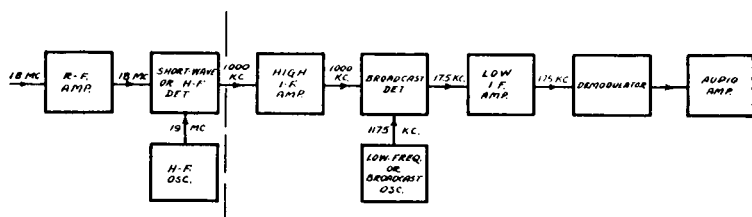

Fig. 38. The frequencies to which the various circuits of this double conversion superheterodyne are tuned, are designated on the diagram. Note especially which units of this set are fixed tuned, as explained in the accompanying text.

tion of the receiver, we shall trace the path of an 18-megacycle (18,000 kc.) signal through the receiver. This will at the same time illustrate the frequency to which the various circuits are tuned, consequently the frequency at which the circuits should be aligned. It is, of course, possible that other alignment frequencies may be specified, but the figures given will serve as suitable examples. To begin with, the received 18-megacycle signal is impressed on the r-f. amplifier and after being amplified, is fed to the short-wave detector or the high-frequency mixer. In some cases the r-f. amplifier is not present, so that the received high-

frequency signal is fed directly into the high-frequency or short-wave detector. We assume that the design of the receiver is such that the first intermediate frequency produced is 1000 kc. Consequently the high-frequency oscillator will generate a 19-megacycle (19,000 kc.) signal, which is fed into the mixer, wherein, as a result of the operation of the tube, the difference frequency of 1000 kc. is produced and fed into the high-frequency intermediate amplifier. This 1000-kc. signal constitutes the high intermediate-frequency signal. Thus is completed the first conversion.

After due amplification, this high intermediate-frequency signal is fed into the second mixer or broadcast detector. The design of the receiver is assumed to be such that the low intermediate frequency in the broadcast section is 175 kc. In order that this signal be developed, the low-frequency oscillator generates a voltage which is 175 kc. higher than the signal fed into the broadcast detector. This means that the oscillator signal is 1175 kc. As a result of the operation of the broadcast detector, the 175-kc. intermediate frequency signal is developed and fed into the low intermediate-frequency amplifier and, in the usual manner, reaches the demodulator tube, wherein the signal is demodulated and the audio voltage is fed into the audio amplifier.

It is significant to note that in a receiver of this type only the r-f., high-frequency detector and high-frequency oscillator are variable tuned. The high-frequency intermediate amplifier, the broadcast detector and the low-frequency oscillator are fixed tuned to frequencies which are independent of the signal being received. This becomes evident upon analysis of the circuit, since the frequency relation between the received signal and the high-frequency oscillator is always such that the difference frequency of 1000 kc. is developed. Since the input to the high-frequency intermediate amplifier is a fixed frequency, the input to the broadcast detector is likewise of fixed frequency. Since the low-frequency intermediate amplifier is likewise a fixed frequency, irrespective of the frequency of the original signal received, the low-frequency oscillator likewise can be a fixed frequency.

As far as alignment is concerned, we can divide this double conversion system into two separate sections and handle them as if they were two separate superheterodyne receivers connected in tandem or series. For example, that part of the circuit to the right of the dotted line constitutes a complete superheterodyne receiver with its input circuit tuned to 1000 kc. and its i-f. ampli-

fier tuned to 175 kc. It is possible to view this system as being an r-f. amplifier fixed tuned to 1000 kc., and an oscillator fixed tuned to 1175 kc. Alignment would then be carried out at 1000 kc. in the input circuit of the high intermediate-frequency amplifier and the broadcast detector, and alignment of the low-frequency oscillator would take place at 1175 kc. In turn, alignment of the low-frequency intermediate amplifier would take place at 175 kc. The order of alignment would be in conformity with what has already been said in connection with the conventional superheterodyne receiver.

Let us now consider this system to the left of the dotted line. In accordance with the frequencies mentioned, the high-frequency r-f. amplifier, the high-frequency or short-wave detector and the high-frequency oscillator would be aligned over the normal tuning band—bearing in mind that the difference frequency out of the high-frequency detector is 1000 kc. The alignment procedure here is similar to that described for the ordinary superheterodyne.

Converter Alignment

We want to point out that the circuit to the left of the dotted line in Fig. 38 is the equivalent of a normal converter system, when it is contained in a separate unit distinct from the rest of the circuit. From the viewpoint of alignment, it is aligned in conventional manner. If, for example, this converter were used with a tuned radio-frequency receiver, then the complete combination is an ordinary superheterodyne receiver, wherein the converter supplies the ordinary mixer and oscillator, and the TRF receiver supplies the intermediate-frequency amplifier and demodulator.

In some instances, such converter systems include a wave trap in series with the antenna circuit, or at least in the antenna circuit. This wave trap is tuned to the output frequency of the converter, which in Fig. 38, would be 1000 kc. The reason for the trap is to eliminate interference which may arise because the 1000-kc. amplifier circuit is within the broadcast band. In some instances, such interference is picked up by the lead which connects the high-frequency or short-wave detector or converter detector, to the high-frequency intermediate amplifier.

Beat Oscillator Alignment for C-W. Reception

There are some short-wave superheterodyne receivers which are equipped with a beat oscillator to be used for C-W. reception. The discussion to follow is separate and distinct from that relating to the presence of a beat oscillator as a carrier indicator.

Referring to the C-W. beat oscillator, the alignment of this oscillator is carried out by first aligning the receiver in normal manner. After the receiver has been thoroughly aligned, so that it is in perfect order for the reception of modulated waves, then an unmodulated carrier of the rated intermediate frequency is fed into the intermediate-frequency amplifier. The beat-frequency oscillator is then turned on and tuned to 1000 cycles higher than the rated intermediate frequency. In other words, if the intermediate frequency of the mixer is 456 kc., the beat oscillator is tuned to 457 kc., in order to develop a 1000-cycle note in the output. In some instances the beat oscillator is of the variable tuned type, so as to enable a choice of output audio frequencies for C-W. reception. In this case, it is best to adjust the beat-frequency oscillator so that its frequency is either about 1000 cycles above or below the i-f. peak of the receiver. In this way it is possible to reduce the interference by shifting from one side of the i-f. peak to the other side at which the interference may be lower. The reason for the procedure indicated above is to reduce the strength of the audio image signal.

Adjusting 10-KC. Audio Filters

It is possible that this item belongs among audio-frequency subjects, yet we feel that it should be mentioned at this time, because, if such a filter is incorporated in a receiver, it is usually referred to when the subject of alignment is discussed. As it happens, these filter networks seldom require readjustment; however, in the event that they do, the following should be of some value.

These filters, located in the plate circuit of the demodulator tube, or in the audio system, are usually arranged to cut-off at 10 kc. See Fig. 39. Their adjustment requires that 10 kc. or 10,000 cycles be available for checking. This signal can be obtained in

two ways. Naturally the most convenient method is the use of a variable audio oscillator. However, if such a unit is not available, the following method can be applied:

Set the receiver to its lowest broadcast frequency position. Let us assume this is 540 kc. Now insert a 100,000-ohm resistor between the plate of the mixer tube and the plate-voltage supply lead at the plate terminal of the socket. Then connect a .01-mf. condenser between the plate terminal of the mixer tube and the plate terminal of the demodulator, or to that terminal to which the high side of the audio filter is connected. The next step is to establish the setting of the receiver oscillator when the re-

Fig. 39. When adjusting a 10-kc. audio filter circuit a 100,000-ohm resistor is connected in series with the mixer plate and the B supply and a .01-mf. condenser between the plate and the points indicated on the right.

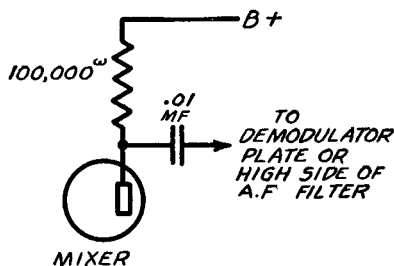

ceiver is tuned to 540 kc. It might be that the lowest broadcast-frequency position on this receiver is 550 kc. instead of 540 kc. This is not an item of moment. Whatever this setting may be, establish the frequency of the receiver oscillator. The frequency of the receiver oscillator for any setting of the tuning dial, is equal to the setting of the dial plus the i-f. peak. Thus, if the i-f. peak in the receiver, we are using as an illustration, is 260 kc., the setting of the oscillator, when the receiver is tuned to 540 kc., is 800 kc. The signal generator is now placed in operation and arranged to feed an *unmodulated* carrier into the receiver. Adjust the signal generator to *zero beat* with the receiver oscillator. This means that the signal generator is tuned to 800 kc. Any difference in tuning between the receiver oscillator and the signal generator will result in an audio beat. The coupling condenser previously mentioned is inserted so as to feed the output of the mixer tube directly to the second detector or demodulator plate. After the zero beat setting has been established, increase the frequency of the signal generator 10 kc. This will develop the audio beat of 10 kc. Now adjust the audio filter for minimum output, which means cut-off at 10 kc.

Determining Unknown I-F. Peaks

In general it can safely be assumed that the i-f. peak of the receiver lies somewhere between 100 kc. and 550 kc. The pro-

cedure is to connect the signal generator to the grid of the last i-f. tube. This connection should be made in the manner used for i-f. alignment and the oscillator section of the tuning condenser should be shorted. Starting at 550 kc., the signal generator frequency is decreased until the output meter shows a reading. The speaker is preferably left connected while this operation is carried out, so that the audio note will be heard as the peak is passed. The frequency at which the note is first heard is probably the intermediate frequency. To check that it is not a subharmonic of the intermediate frequency, the signal generator should be set to twice the frequency at which the note is heard; if no signal is heard at this point, then the first frequency is the i-f. peak. As a further check, it is suggested that the signal generator be set to half the i-f. and the signal should be heard under these conditions.

A concrete example will simplify the above explanation. Suppose that beginning with signal generator frequency set at 550 kc., the frequency is decreased slowly and that when 430 kc. is reached the signal is heard in the speaker. The signal generator is set at twice 430 kc. or 860 kc. and at this setting no signal should be heard. With the signal generator set at one half 430 kc. or 215 kc., the signal should be heard. If the above conditions are fulfilled then the *approximate* i-f. peak is 430 kc.

Use of Signal Generator Harmonics

It is possible to use harmonics of the available fundamental frequencies to effect alignment, provided proper care is exercised to avoid confusing the order of the harmonics. In the first place, it should be clear that when an oscillator is generating a certain frequency, it is at the same time producing a whole train of harmonic frequencies. These harmonics are frequencies which are integral multiples of the fundamental. An example will make this clear. Suppose that the oscillator is set at 1000 kc. Then the signal generator is producing not only 1000 kc., but is generating also 2000 kc., 3000 kc., 4000 kc., 5000 kc., and so on. It should be understood that the intensity of the harmonics diminishes rapidly and in general the higher the order of the harmonic, the weaker is the amplitude of the harmonic voltage.

What will follow is of general interest in the event that the

range of the signal generator is limited and it is necessary to employ harmonics of the fundamental without definite calibration of these harmonics. Of course, if the signal generator is calibrated throughout its range, inclusive of the usable harmonics, then the fact that harmonics are employed is of no consequence. We are primarily interested in the extent to which harmonics can be used in alignment work. For example, can the 25th harmonic of 1000 kc. signal be used to align a receiver at 25,000 kc.? The answer is no. It must be remembered that a 24,000-kc. and 26,000-kc. signal are present as well as the 25,000-kc. signal and it is very possible that the receiver will be aligned at the wrong frequency, say, 24,000 kc. instead of the correct 25,000 kc. The possibility of image confusion in superheterodynes adds to the difficulties inherent in the use of high order harmonics, as can readily be seen.

We have just cited an instance in which it would be inadvisable to use a harmonic to effect alignment. We now wish to show how a harmonic can be used to advantage where the signal generator has a limited frequency range. Suppose that the signal generator available has a maximum frequency range of 10,000 kc. and it is desired to align a receiver at 18 mc. The alignment is carried out by setting the signal generator at 9 mc. The second harmonic will now be 18 mc., which is the desired frequency. The possible confusion of the other harmonics does not exist in this case, because the two adjacent frequencies, which might be confused, are 9 mc. and 27 mc. These are so widely separated from the alignment frequency that the possibility of confusion is negligible. As a matter of fact, there is perhaps an advantage in using the second harmonic in this case, since there is less reaction between the signal generator and the receiver when a harmonic of the oscillator is being picked off.

As the antenna coil is aligned, there will be very little tendency for the frequency of the signal generator to be changed. In addition, where it is impossible to attenuate the signal sufficiently at the higher frequencies, it is desirable to use the second or third harmonic of the signal generator, since this will provide the desired attenuation. For example, if the alignment is being made at 20 mc. and the attenuator does not cut down the signal to the desired value, then the signal generator can be set at 20

mc./3 or at 6667 kc., and it will then be possible to attenuate the signal to the required value.

As a general rule, harmonics can be safely used up to about the third or fourth without much possibility of confusion. However, we have tried to show that the use of higher order harmonics requires that special care be exercised; we do not recommend that they be used for alignment work except by those experienced in the methods of checking to insure that the receiver is being aligned to the correct harmonic.

Visual Alignment

It is beyond the scope of this book to describe completely the theory and practice of visual alignment. However, we feel that a certain amount of this data is necessary because visual alignment is an operation which is growing in popularity. Furthermore, since we cannot take for granted that you are familiar with the fundamental operations of visual alignment methods which employ the cathode-ray oscillograph, a brief outline of the various functions is given herewith. For more extensive details concerning the cathode-ray oscillograph as applied to alignment, we suggest that you read Rider's "The Cathode-Ray Tube At Work."

In brief, the operation of visual alignment processes is as follows: Whereas the signal generator, referred to in previous chapters in connection with the conventional form of alignment, generates a modulated signal of a single frequency, visual alignment employing the cathode-ray oscillograph utilizes a signal generator which is frequency-modulated over a certain band of frequencies. By frequency-modulated we mean that the output of the signal generator automatically varies in frequency over a band of frequencies about the i-f. alignment frequency. A numerical example will clarify this. If the alignment frequency of the i-f. amplifier is 260 kc., the frequency-modulated signal generator produces a continuously varying band of frequencies between 250 kc. and 270 kc. In other words, the device automatically varies the frequency of the output over this 20-kc. band. At one instant the frequency of the output of the signal generator is 250 kc. At the next instant it is 251 kc. At the next instant it is 252 kc., and so forth until 270 kc. is reached, at which

time the frequency starts decreasing to 269 kc., 268 kc., 267 kc., and so forth until the original 250 kc. is reached. Then the same process is repeated over and over again.

The rate at which this change in frequency takes place depends upon the mechanical design of the signal generator. The band of frequencies covered, that is, whether the spread is 20 kc. wide, 30 kc. wide or even 10 kc. wide, also depends upon the design of the system. As a rule, it can be varied by the person operating the device. The carrier signal generated by the signal generator at any one instant is unmodulated. This is in contrast to the usual signal generator, which develops an output carrier that is modulated. The reference to the fact that the band of frequencies generated in this frequency-modulated signal generator varies about the i-f. alignment frequency, is explained above. The fact that the output varies both sides of the rated frequency of the i-f. amplifier is described by the statement that the frequency varies continuously over a band of frequencies about the i-f. alignment frequency.

This frequency-modulated signal is fed into the receiver under alignment, just as if it were a constant frequency signal. After rectification, a voltage appears in the demodulator circuit of the receiver which at any given instant is proportional to the response of the circuits to the frequency which is at that instant passing through the circuit. In other words, if the signal is being fed through the i-f. circuit, then the voltage at the detector after rectification is proportional to the response of the i-f. amplifier. If the signal is fed into the antenna circuit, then the voltage appearing in the detector circuit after rectification is proportional to the response of all of the tuned circuits in the receiver through which the signal was passed. This voltage is applied to the vertical plates of the cathode-ray oscillograph and thus the vertical deflection of the cathode-ray beam is proportional to the magnitude of the signal which reaches the detector. Expressed in another manner, the vertical deflection upon the oscillograph beam is indicative of the response of the various circuits through which the signal passes to the demodulator.

A sweep voltage is generated in the oscillograph by a separate part of the oscillograph unit and the function of this sweep voltage is to move the cathode-ray beam in the horizontal direction across the screen. This sweep voltage is synchronized with the frequency-modulated signal. By this is meant that the horizontal displacement of the cathode-ray beam takes place at a certain

definite rate and phase with respect to the frequency generated by the signal generator. Synchronizing the oscillograph sweep voltage with the frequency-modulated oscillator makes it possible to trace out upon the oscillograph screen the selectivity response of the circuits being tested. The horizontal motion of the cathode-ray beam is proportional to the frequency and the vertical deflection is proportional to the receiver response at the frequency in question.

The cathode-ray oscillograph, its sweep voltage and the frequency-modulated signal generator makes it possible to see the type of curve which would be obtained if the regular type of signal generator were used and the output meter indication were charted, as the frequency output of the signal generator was manually changed over a band of frequencies 10 or 20 kc. each side of the rated i-f. peak. Once again we say that this is a very brief explanation of the manner in which visual alignment is accomplished. While it is true that actual application is a simple matter, a full explanation would require more space than can possibly be devoted in this volume. Again we refer to the previously mentioned book, "The Cathode-Ray Tube At Work."

Perhaps the most useful application of the visual alignment method is the alignment of the wide band-pass i-f. amplifiers found in a great many of the new receivers, which have response curves such as shown in Figs. 13E to 13I. It should, of course, be understood that visual alignment is but one function of the cathode-ray oscillograph and that its development is not founded upon this one function. It is also important to understand that the advantage found in visual alignment is that one can actually see the response curve and thereby develop far more accurate results.

When aligning i-f. amplifiers by means of the visual method, it is of utmost importance that each stage be aligned individually, *beginning at the last i-f. stage*. By the last i-f. stage we mean the one nearest the demodulator tube. Because this operation is so important, we feel that it will not be amiss to go into some detail with reference to this procedure. The vertical deflection plates of the oscillograph are connected across the demodulator load. In a diode type of a demodulator, this would be the diode load resistor. In a triode type of demodulator, the cathode-ray

oscillograph would be connected across the high side of the plate load and ground. The synchronizing pulse terminals on the oscillograph are connected to the synchronizing pulse terminals on the frequency-modulated signal generator. The output terminals of the frequency-modulated signal generator are connected in the usual manner; that is, the ground terminal is connected to the ground or chassis and the high side is connected to the grid of the last i-f. tube. The grid lead, which is removed from the last i-f. tube, should not be left free; instead it should be returned to the grid through a resistor of 25,000 ohms. Care should be taken that the "high" lead from the signal generator is fully shielded up to the grid cap and that the shield is grounded to the receiver chassis. If instability is encountered when aligning the last i-f. stage of a sensitive receiver, then the first i-f. tube should be removed. This precaution will seldom be required, but we mention it nevertheless. When the alignment of the last i-f. transformer is completed, the signal generator is connected to the grid of the preceding i-f. tube in the exact manner already described. Naturally, the resistor previously inserted into the grid circuit of the i-f. tube will be moved from that tube to the preceding tube—to which the signal generator now is connected. Ultimately, the signal generator is connected to the first detector tube control grid.

As far as the response is concerned, that is, the type of resonance curve which should appear upon the screen, that depends upon the type of system being aligned. An examination of the circuit is essential and full comprehension of the type of resonance curve to be expected from certain systems will naturally guide the adjustments. At the same time, reference to service literature concerning the receiver being worked upon will also help, because such data often contains specific reference to the type of resonance curve developed by the system. One primary point of importance in connection with i-f. amplifier response curves is that normal operation of the system calls for a symmetrical resonance curve. Another item of importance is that the initial alignment of wide band-pass systems requires that the circuit be first aligned for maximum selectivity and then again aligned for wide band-pass.

Several "don'ts" which must be borne in mind during such visual alignment are of the following nature. 1, be certain that the input to the intermediate-frequency amplifier does not overload the tubes. The effect of such overload is to broaden the response beyond the normal point and the effect of overload is

indicated by a flat top, such as is shown in Fig. 40. 2, make certain that the i-f. amplifier is free from regeneration. The presence of regeneration will sharpen the selectivity curve beyond the normal point, an example of which is shown in Fig. 41. If the regeneration is sufficient so that oscillation actually exists, the response curve which appears will resemble that shown in Fig. 42.

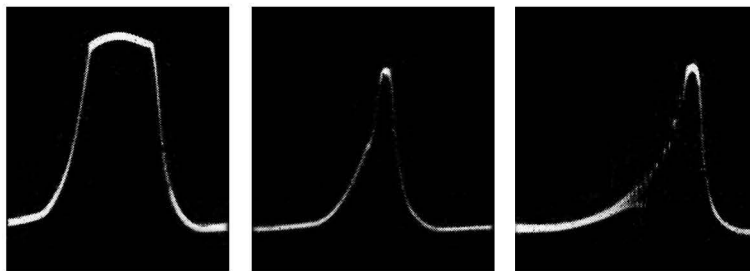

Figs. 40, left, 41, middle, and 42. The flat-topped curve of Fig. 40 is the result of too large an input to the i-f. amplifier and a consequent overloading of the tubes. A sharpening of the selectivity curve, Fig. 41, results when regeneration is present and when it is such that oscillation appears, the response curve of Fig. 42 results.

The response curves illustrated in Figs. 40, 41 and 42 were made with the visual alignment system which develops a single image. Such curves are not symmetrical and if they were taken with the type of visual alignment system which develops a double image, the pattern would be of the double image character illustrated in Fig. 14A.

Visual Alignment at 600 kc.

There has been some confusion as to the proper procedure to be followed in effecting the alignment of the series oscillator trimmer at the low-frequency end of a band, say at 600 kc. To clear up this matter, we shall go over the procedure in some detail. To take a concrete illustration, we shall assume that the intermediate frequency is 450 kc.

The first step, after aligning the i-f. amplifier, is to align the r-f., detector, and oscillator shunt trimmers in the conventional way at the high-frequency end of the broadcast band, say 1400 kc. With this com-

pleted, the signal generator is set at 600 kc. and connected to the receiver antenna post. It should be understood that the frequency-modulated signal generator is producing not only 600 kc., but a band of frequencies ranging from say 585 to 615 kc. The receiver is tuned to 600 kc. and the resonance curve appears on the screen. From this point on, we shall consider first the procedure when the single image system of frequency modulation is used.

In this case there will be just a single trace, the peak of which may or may not be in the center of the trace. The adjustment of the series oscillator trimmer should then be made so that *the resonance curve has the greatest height*, regardless of whether this maximum peak occurs in the middle of the trace. This is highly important and even though it may be necessary to change the receiver tuning slightly, the procedure is to adjust the trimmer for the greatest peak height. The significance of the peak being off center is that the calibration of the receiver is off at 600 kc. If the oscillator trimmer is adjusted so that the peak is in the center of the trace when the receiver and signal generator are tuned to 600 kc., then the sensitivity and selectivity of the receiver are sacrificed for the sake of an improvement in the calibration of the receiver. This is certainly an undesirable condition. Fig. 43 shows the *incorrect* adjustment, which results

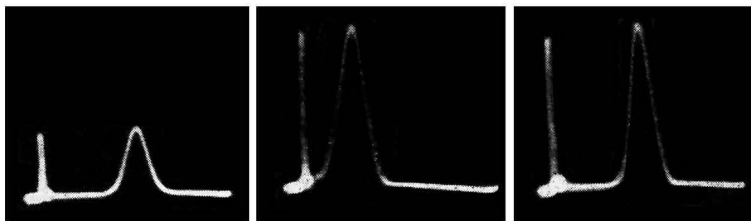

Figs. 43, left, 44, middle, and 45. When aligning at 600 kc., the peak should have maximum amplitude, regardless of its position on the trace. The oscillogram of Fig. 43 is incorrect, as the amplitude is too small when compared with that of Fig. 44, even though the curve is off center. The curve was centered, Fig. 45, by changing the receiver tuning from 600 kc. to 595 kc.

when the peak is centered, whereas Fig. 44 shows the improvement in response which resulted when the series oscillator trimmer was adjusted for maximum height, in spite of the fact that the peak happened to occur off the center of the trace. To bring the peak back to the center of the trace, the receiver tuning can be

changed and the amount by which it must be changed to bring the peak to the center indicates how far off the receiver calibration is. Referring to Fig. 45, the peak was brought to the center by changing the receiver tuning from 600 kc. to 595 kc. This means that the receiver calibration at 600 kc. is off by 5 kc. It should be clearly understood that the optimum adjustment is attained when the r-f. and detector stages are tuned to the incoming signal and the oscillator frequency is higher than the signal frequency by the amount of the intermediate frequency. In this case, the r-f. and detector stages are tuned to 600 kc. and the oscillator frequency is 1050 kc.

The procedure to be followed when the double image system is used requires further explanation. In general, a double trace will appear on the screen when the receiver and the signal generator are tuned to 600 kc. Now the important point is this: in contrast to the usual procedure, wherein the trimmer adjustments are made so as to bring the two curves into coincidence, in this case the series oscillator trimmer is adjusted for maximum output

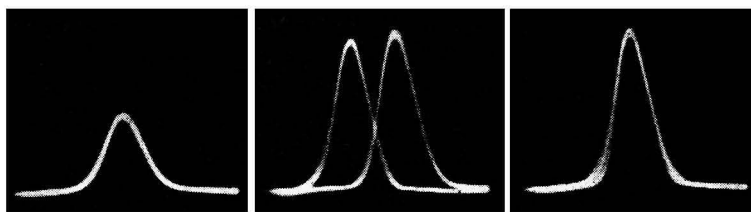

Figs. 46, left, 47, middle, and 48. When a double-image system is used, a double trace will generally appear when receiver and signal generator are tuned to 600 kc. If the trimmers are so adjusted that the curves coincide, Fig. 46, but the amplitude is too small, then they should be readjusted until the curves attain maximum amplitude, even though they do not coincide, Fig. 47. These can be brought together, Fig. 48, by changing the receiver tuning.

or height, regardless of whether this may or may not bring the two curves together. Fig. 46 shows the *incorrect* adjustment made so that the two curves are brought into coincidence. The improvement in sensitivity, when the series oscillator trimmer is adjusted so that the peak height of the curves is a maximum, is shown in Fig. 47. Note that while the curves no longer coincide,

at the same time the gain and selectivity of the receiver have been appreciably increased. The curves, of course, can be brought together by retuning the receiver. Again the amount by which it is necessary to change the receiver tuning is a measure of the extent to which the calibration is off. The appearance of the trace when the curves are brought together is shown in Fig. 48.

Frequency Range of Visual Alignment

There is nothing gained in using visual alignment for frequencies above the broadcast band. However, the oscillograph connections to the receiver may be left undisturbed, the frequency modulator disconnected and an ordinary modulated signal fed into the receiver. In this case the oscillograph functions simply as an output meter as previously explained and if AVC is used, then the signal input must be kept low.