

ELECTRONIC TECHNOLOGY SERIES

LOW-FREQUENCY AMPLIFIERS

a **RIDER** **publication**

\$1.80

LOW-FREQUENCY AMPLIFIERS

Edited by
Alexander Schure, Ph.D., Ed.D.

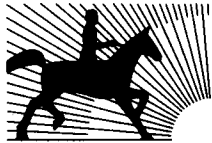

JOHN F. RIDER PUBLISHER, INC.

116 West 14th Street • New York 11, N. Y.

Copyright May 1959 by

JOHN F. RIDER PUBLISHER, INC.

All rights reserved. This book or any parts thereof may not be reproduced in any form or in any language without permission of the publisher.

Library of Congress Catalog Card Number 58-14218

Printed in the United States of America

PREFACE

Research into increased spectrum utilization has resulted in many new techniques in amplifiers serving particular frequency ranges. One of the general classifications of amplifiers concerns itself with those designed to handle the low-frequency spectrum. An evident cause is the tremendous interest in high-fidelity reproduction. The increased interest of design engineers in the low-frequency spectrum has gone beyond the problems of ultralinear amplifiers for monoaural and stereophonic recordings, however. Applications pertaining to what is now considered the low frequencies have resulted in the rise of ultrasonics and other devices in the range above 20,000 cycles. At the low end of the frequency range, d-c amplifiers and servo-amplifier systems are concerned with the very low frequencies, often handling signals below 20 cycles.

This book has been organized to present the major specification for low-frequency amplifiers ranging roughly from zero to 100,000 cycles. The specific problems encountered at the very low ranges are different from those at the upper range; these discussions are treated both in this book and in the companion volume, *Low-Frequency Amplifier Systems*, dealing with specific design problems. The mathematical treatment employed throughout has been kept simple, but the analyses are sufficiently extensive to permit the interested technician or student to develop a full comprehension of the pertinent theory.

Specific attention is given to the basic concepts of the low-frequency spectrum; the problem of amplifier circuit components, and their appropriate symbols; currents and voltages in grid and plate circuits; tube voltages and currents and their symbols; the equivalent circuit, its use and associated problem solutions; grid-

bias systems; amplifier criteria; frequency response; the decibel and related problems; decibel reference levels; frequency-response curves; the Fletcher-Munson contours and the information derived from them; summarization of tube characteristics; voltage gain of a pentode; the use of load lines; amplifier distortion; the problems pertaining to single-ended power amplifiers including function, classes, ratings, and calculation of power output and plate efficiency; the circuits, harmonic content and systems of push-pull power amplifiers. The principles of transistor amplifiers are also dealt with, sufficient attention being given to a comparison of transistor characteristics, the establishment of operating points, biasing methods and stabilization computations. Thus, a foundation is provided upon which more advanced concepts can be built.

Grateful acknowledgment is made to the staff of the New York Institute of Technology for its assistance in the preparation of this book.

New York, N. Y.
May, 1959

A. S.

CONTENTS

<i>Chapter</i>		<i>Page</i>
1	Principles of Amplification	1
2	Fundamental Amplifier Considerations	16
3	Low-Frequency Voltage Amplifiers	32
4	Single-Ended Power Amplifiers	45
5	Push-Pull Power Amplifiers	57
6	Principles of Transistor Amplifiers	66

Chapter 1

PRINCIPLES OF AMPLIFICATION

1. The Low-Frequency Spectrum

The demands of military electronics, communications, and entertainment have brought about a gradual but insistent widening of all frequency spectrums over the passing years. The greatest strides have been made in the high-frequency ranges (super-highs, microwaves, and beyond). However, the signal region, once limited to audio frequencies, has also undergone its share of expansion.

Today, the low-frequency spectrum may be said to start at zero cycles per second. Vacuum-tube voltmeters, summing amplifiers, computer integrator and differentiator circuits of some varieties, and many other important devices require highly stable, completely reliable d-c amplifiers in which the highest gain is obtained at zero frequency. Many servo-amplifier systems in which d-c stability and sensitivity are very important factors utilize correction signals which range from a few cycles to 20 or 30 cycles.

The a-f spectrum has also grown well beyond its limits of a few years ago, largely as a result of the clamor for high-fidelity reproduction. Although most authorities agree that near-perfect reproduction of recorded orchestral music can be obtained if the frequency response of the entire system is uniform from about 40 to 15,000 cycles, amplifier designers are still attempting to produce equipment which will be flat over even greater ranges than this. Such ultralinear equipment is designed to offer frequencies that are well beyond the scope of normal human hearing — for whatever purpose it may serve!

The increased interest in, and application of ultrasonics has added to the low-frequency spectrum a new range, from 20,000

cycles to approximately 100,000 cycles. Standard audio amplifiers are generally incapable of retaining anything like normal gain in this region. Thus, ultrasonic amplifiers create new problems for the design engineer. Such problems, although not insuperable, demand a new approach and a fresh outlook, particularly regarding the choice of amplifier components, including vacuum tubes.

Thus, the low-frequency spectrum may be considered to extend roughly from zero cycles to 100,000 cycles. The problems encountered at the d-c end are vastly different from those at the upper extreme; these discussions are treated separately in this book. On the other hand, low-frequency amplifiers have so much in common at a fundamental level that an overall picture encompassing the general principles of amplification is very worthwhile.

2. Amplifier Components

The vacuum tube is used most widely to amplify signal voltages which must be built up to larger magnitudes to accomplish some specific result. Figure 1 shows the fundamental elements of a typical amplifier. Although a pentode is used in this illustration, the circuit is equally applicable to triode tubes if the screen-grid and suppressor-grid elements are omitted.

In a vacuum-tube amplifier, the fundamental process involves the application of a varying voltage (*i.e.* signal frequency) between the control grid and the reference ground (e_g in Fig. 1). The action

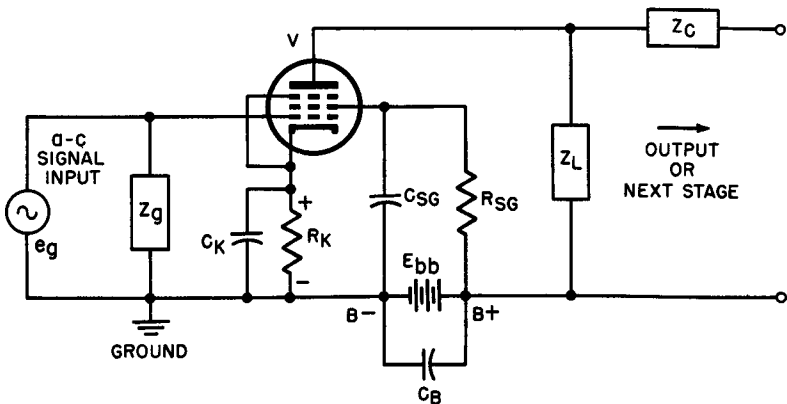

Fig. 1. Amplifier circuit including tube and associated circuit components.

of the circuit is such that e_g gives rise to a varying plate current of the same frequency which flows through a relatively high impedance Z_L to cause a voltage drop of signal frequency having a greater amplitude than e_g . Since this circuit is powered by a d-c source (E_{bb}), there will be voltages and currents present that may be pure dc or pulsating dc. Pulsating dc may be analyzed into two components: a pure d-c component and an a-c component of signal frequency. Thus, the individual parts associated with the vacuum tube are selected with a view to presenting impedances to the various currents which will produce the desired effect. The capacitances of C_b , C_k , and C_{sg} are all large enough to allow a low impedance at the signal frequency to bypass those current components. R_k and R_{sg} are both strictly d-c components in which no ac is expected to flow. Z_g , Z_L , and Z_c must be selected to handle both a-c and d-c components of the current, as will be seen later on.

For clarity and consistency, these amplifier parts will be referred to either by symbol or by name according to the following list:

Amplifier Circuit Components And Their Symbols

Z_g	— Control-grid circuit impedance
Z_L	— Plate-load impedance
Z_c	— Coupling impedance
R_k	— Bias resistance
C_k	— Cathode-bypass capacitor
R_{sg}	— Screen resistor
C_{sg}	— Screen-bypass capacitor
C_b	— Plate-bypass capacitor
E_{bb}	— Supply voltage, dc
V	— Amplifier tube

3. Currents and Voltages in Grid and Plate Circuits

Grid circuit voltages — The voltages on the various grids and the plate of an amplifier tube may be referred to a common power-supply voltage level (often the most negative potential or the “B minus”) or they may be stated with reference to the potential of the tube cathode. The reference level is often labeled “ground” as in Fig. 1 although this point is seldom directly connected to the

ground. When an operating potential is referred to the cathode, this fact is usually stated to avoid confusion.

The signal voltage e_g is impressed between the control grid and ground in the typical circuit of Fig. 1. In most normal voltage amplifiers the current in the grid circuit is zero. This is achieved by making the control-grid potential sufficiently negative with respect to the cathode to prevent the positive half-cycles of the input voltage from swinging the control grid positive with respect to the cathode. Among the various commonly used methods of obtaining this *negative grid bias*, perhaps the most popular is the use of a resistor in series with the cathode (R_k). Normal quiescent plate current flowing through the tube causes a voltage drop to appear across R_k having such polarity that the cathode becomes positive with respect to ground. With the control grid connected to ground through Z_g , the relative potentials of grid and cathode differ by an amount equal to the voltage drop across R_k , the grid being negative with respect to the positive cathode. Calling this fixed bias E_c , the relationship between E_c and e_g may be pictured as in Fig. 2. The instantaneous

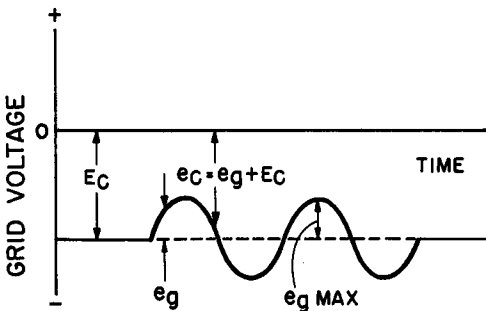

Fig. 2. Grid-voltage waveform.

sum of e_g and E_c is a unidirectional pulsating voltage on the negative side of the zero-voltage axis. The superimposition of the signal voltage or a-c component upon the bias voltage or d-c component thus gives rise to a fluctuating voltage which never rises into the positive region; hence the control grid circuit current is normally zero.

Plate-circuit voltages and currents — A vacuum tube does not permit electron current to flow through it in the reverse direction, that is, from plate to cathode. Nevertheless, when an alternating voltage e_g is applied to the grid of the tube, an alternating plate-current component is present in the plate circuit, as shown in Fig.

3. Although the plate current i_p (referred to the zero axis) is a varying unidirectional current, it may be considered as being composed of two components: I_b , the steady quiescent plate current and superimposed upon it, i_p , the alternating component.

Since the plate current is unidirectional, i_p is never as large as I_b ; i_p adds to I_b on one half-cycle and subtracts from it on the other. In a distortion-free amplifier, the alternating component i_p has iden-

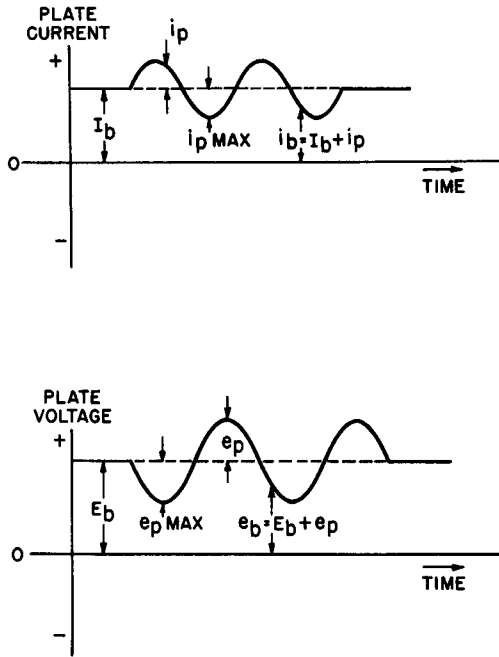

Fig. 3. Graphs showing plate-current and plate-voltage waveforms.

tically the same waveform as the input voltage e_g . This current produces the useful output of the amplifier. The symbol i_p is used to represent any *instantaneous* value of the a-c component of the plate current while $i_{p \text{ max}}$ is synonymous with the latter's *peak* value in either direction.

With no signal applied to the tube grid, the voltage on the plate is E_b . Since a steady plate current flows from cathode to plate even in the absence of a signal, the actual plate voltage E_b is less than the supply voltage E_{bb} by an amount equal to the d-c voltage

drop across the plate-load impedance Z_L . This quiescent drop is often symbolized by E_L . On the other hand, when the alternating component of the plate current is in the presence of signal and flows through Z_L , an alternating voltage drop e_p appears across this impedance so that the *instantaneous plate voltage* e_b referred to the zero axis at any time is given by the expression:

$$e_b = e_p + E_b \quad (1)$$

Also, the expression for quiescent voltage conditions in the plate circuit may be written:

$$E_b = E_{bb} - E_L \quad (2)$$

In accordance with the definitions set forth above, various plate and grid voltages and currents will be symbolized as follows:

Tube Voltages And Currents And Their Symbols

E_{bb}	— Plate-supply voltage
E_b	— Quiescent plate voltage
I_b	— Quiescent plate current
E_c	— Fixed grid bias
e_b	— Actual instantaneous plate voltage with signal applied (referred to zero axis)
e_p	— Alternating voltage drop in load impedance Z_L
$e_{p \max}$	— Peak voltage drop across Z_L
i_b	— Actual instantaneous plate current in presence of signal referred to zero axis
i_p	— A-c component of the complex plate current
$i_{p \max}$	— Peak value of a-c component of plate current
e_g	— A-c voltage applied as signal input to control grid
e_c	— Pulsating d-c voltage applied between grid and cathode referred to zero axis
$e_{g \max}$	— Peak value of a-c signal input voltage.

Screen-grid voltage and current — When a pentode or a beam

power tube is employed as an amplifier, the screen grid is operated at a d-c potential that may be greater than, less than, or the same as the actual plate voltage. To serve as an adequate screen and to reduce effectively the secondary emission from the plate, the screen must at the same time be at *ground potential* with respect to the signal voltages in the circuit. The latter effect is realized by connecting the screen grid to a common ground point through a bypass capacitor (C_{sg} in Fig. 1) of capacitance sufficiently large to offer a very low impedance path to the signal frequencies. Under these conditions, a signal voltage drop cannot appear across any screen impedance that may be used.

If the screen grid is to be operated at a d-c potential lower than that of the B+ value of the power supply, a dropping resistor R_{sg} is usually inserted in series between the screen grid and the B+ terminal. The value of this resistor is easily obtained by applying Ohm's law as follows:

$$R_{sg} = \frac{E_{bb} - E_{sg}}{I_{sg}}$$

in which E_{sg} is the desired screen potential referred to ground and I_{sg} is the tube's rated screen current in amperes.

The suppressor grid is commonly connected directly to the cathode by a short external jumper between appropriate terminals on the tube socket. In some tubes, notably power amplifiers, the suppressor grid is internally connected to the cathode inside the tube envelope. Some circuits call for the connection of the suppressor grid to ground rather than to cathode, ground being quite close to cathode potential.

4. The Use of an Equivalent Circuit

The design of an amplifier and an analysis of its performance is substantially simplified by reducing the elements of the circuit to an equivalent form. A fundamental triode amplifier (Fig. 4A) contains a source of control-grid bias (in this case a grid battery), a source of plate potential, the vacuum tube, and the load impedance into which the tube delivers power. A small signal voltage e_p from a microphone, phono-playback, or some other signal source is applied between the grid and cathode. In the absence of signal a steady

plate current I_b flows in the tube; with the input voltage applied, the plate current varies from its quiescent value and, as explained previously, is designated at i_p . This varying current causes voltage variations e_p across the load impedance Z_L .

Since e_g is an a-c voltage, any change in e_g must produce a voltage drop of $Z_L i_p$ in the plate impedance since i_p is the current that results from the application of e_g . Thus, the signal voltage may be considered to reduce the actual plate voltage to the extent of $Z_L i_p$. Therefore, the change in plate current resulting from the application of e_g is a function of both the grid voltage increment e_g and the reduction factor $-Z_L i_p$.

The amplification factor (μ) is defined as the ratio of plate-voltage change to grid-voltage change for a constant value of plate current. The relative effect of grid- and plate-voltage change to produce an equal change in plate current is also measured by μ . The change in plate current is the same as would occur if the plate voltage were changed by an amount equal to $\mu e_g - (Z_L i_p)$ volts.

Since we are dealing entirely with dynamic conditions, we may write:

$$i_p = \frac{- (\mu e_g + Z_L i_p)}{r_p} \quad (3)$$

where r_p is the dynamic plate resistance of the tube which is defined as the ratio of a change in plate voltage to the accompanying change of plate current, with the grid voltage held constant. By clearing fractions and solving for i_p , we obtain:

$$i_p = \frac{- \mu e_g}{r_p + Z_L} \quad (4)$$

Examination of this equation reveals that we are dealing with a circuit in which the current (i_p) is determined by the voltage ($-\mu e_g$) acting across a pair of resistances in series: r_p and Z_L . In other words, the vacuum-tube amplifier circuit may be represented by its equivalent in the form shown in Fig. 4B. In accordance with this concept, the tube behaves exactly as though there were a generator producing a voltage $-\mu e_g$ inside the tube which then gives rise to a current i_p whose magnitude is limited by the series resistances r_p and Z_L .

The equation of the equivalent circuit may be used to determine the voltage amplification of the circuit. Voltage amplification

(A) is defined as the ratio of the useful signal-voltage output (*i.e.* the voltage across Z_L or e_p) to the input signal voltage e_g , or:

$$A = \frac{e_p}{-e_g} \tag{5}$$

The minus sign indicates that there is a 180° phase reversal between e_g and e_p .*

Since the voltage drop across the load impedance is:

$$e_p = i_p Z_L \tag{6}$$

we can multiply both sides of Equation 4 by Z_L and obtain

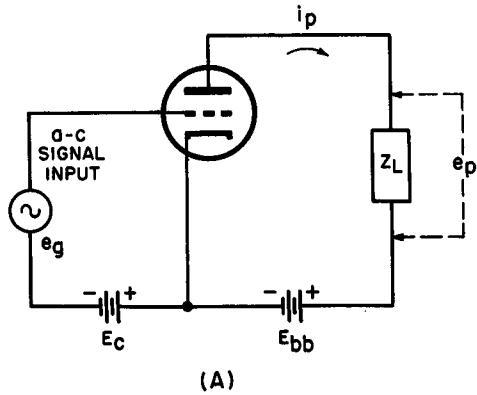
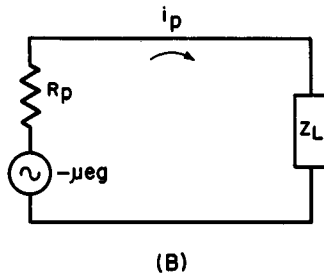

Fig. 4. Amplifier circuits. (A) actual and (B) equivalent.



* Referring to Fig. 4, a positive-going voltage applied to the grid causes the plate current to increase through Z_L . The increased voltage drop across the load impedance results in a reduction of available plate voltage (*i.e.* voltage between plate and cathode). Hence, a positive-going grid voltage gives rise to a negative-going plate voltage, or a 180° shift in phase between e_g and e_p .

$$e_p = i_p Z_L = \frac{-\mu e_g Z_L}{r_p + Z_L} \quad (7)$$

Dividing both sides of Equation 7 by e_g yields

$$\frac{e_p}{-e_g} = A = \frac{\mu Z_L}{r_p + Z_L} \quad (8)$$

Problem 1. What voltage gain may be expected from one triode section of a 6SL7-GT operating at a plate voltage of 250 volts, a grid bias of -2 volts, and working into a 100,000-ohm load impedance?

Solution. According to the receiving tube manual, at these circuit voltages the 6SL7-GT triode has a μ of 70 and a plate resistance of 44,000 ohms. Substituting the appropriate values in Equation 8:

$$A = \frac{70 \times 100,000}{44,000 + 100,000}$$

$$A = 48.6$$

Note that the actual voltage gain of the circuit does not equal the amplification factor; as a matter of fact, it falls considerably short of this value. As is evident from Equation 8, A can approach μ only when the fraction $Z_L/r_p + Z_L$ approaches unity which, in turn, can happen only if Z_L becomes very much larger than the plate resistance of the tube. The practical limit to the increase of Z_L is established by the d-c voltage drop which takes place across this impedance in the case of resistive loads — a voltage drop that reduces the plate voltage of the tube to the point where its operating point becomes incorrect. When the load is not resistive (as in the case of inductors or transformer primaries), the inductive reactance cannot be raised above the limiting value without increasing the distributed capacitance of the winding beyond the point where distortion becomes intolerable.

The equivalent circuit of the triode amplifier given in Fig. 4B can also be applied to pentodes and beam-power amplifiers. It provides a good indication of the performance that may be anticipated even when μ and r_p are not absolutely constant as assumed in the derivation of the equation.

5. Grid-Bias Systems

Five methods of supplying amplifier control-grid bias are currently in use. Of these, the cathode-resistor method is perhaps the

most popular, followed by bleeder bias, battery bias, series-filament bias and grid bias through a large resistance (approximately 10 megohms) to ground.

Cathode bias (self-bias) — By inserting a resistor of the appropriate value in series with the cathode of the amplifier tube and returning the grid (through a grid resistor) to the common negative point of the circuit, almost any bias value may be obtained (Fig. 5). Plate and screen currents, or merely plate current in the case of

Fig. 5. Schematic of amplifier circuit using cathode bias.

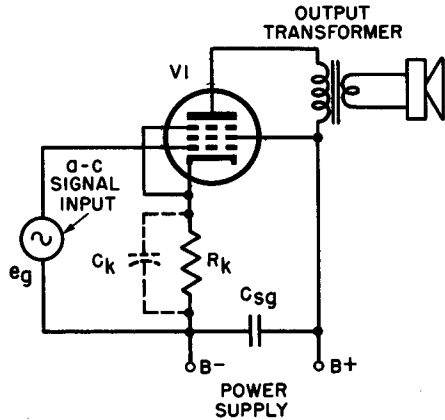

a triode, flow through this resistor and produce a voltage drop across it which places the cathode at the desired positive potential above ground. The grid, being connected to ground through its resistor, is more negative than the cathode by this amount. The resistance required to produce a given bias may be calculated from the following relation:

$$R_k = \frac{E_c}{I_b + I_{sg}} \tag{9}$$

R_k is in ohms if E_c is in volts, and both I_b and I_{sg} are expressed in amperes. Figure 5 is a diagram of a power-amplifier stage working into an output transformer as a plate load. Bias is provided by the drop across R_k while C_k has a large capacitance to bypass the a-c component of i_b around R_k and prevents undesirable variations in bias voltage. Although this is the circuit of a power amplifier, voltage amplifiers of either the triode or pentode variety may employ exactly the same arrangement.

Problem 2. Calculate the size of the bias resistor required to properly bias a 6K6 for maximum signal conditions when the plate voltage is 250 volts.

Solution. With an applied plate voltage of 250 volts, the receiving manual calls for a bias voltage of -18 volts. The maximum signal-plate current is 34 ma and the maximum signal-screen current is 10 ma. Substituting in Equation 9:

$$R_b = \frac{18}{.034 + .010} = \frac{18}{.044}$$

$$= 409 \text{ ohms.}$$

In practice, the nearest obtainable value — probably 400 ohms — is usually selected.

It is also valuable to calculate the necessary power-dissipation rating of such a resistor with any of the standard power equations. For instance, using $W = I^2R$

$$W = 400 (.044)^2$$

$$= 0.8 \text{ watt}$$

To provide an ample safety factor, a 2-watt resistor is specified for this application.

Bleeder bias — The power supply “bleeder” may be tapped to provide a source of bias as illustrated in Fig. 6. In this arrangement, the ground point of the system is a tap on the resistor so that the latter may act as a voltage divider across the power supply. The cathode is returned directly to ground while the grid is connected through its impedance to the negative end of the bleeder. The voltage E_c therefore appears across the tapped section as shown in the

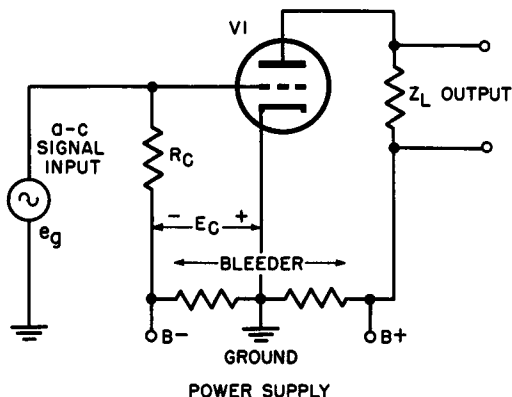

Fig. 6. Schematic of amplifier circuit using bleeder bias.

diagram. Bias obtained in this way is called "bleeder-bias." Note that the amount of negative grid-voltage available is independent of the amplifier-tube action.

Battery bias — Another form of fixed bias may be obtained by using ordinary dry cells, mercury cells, or cells designed specifically for bias service. Although a chemical emf generator has a limited life even if it supplies no power, it is often convenient to use one for bias particularly in applications where batteries are already being employed as sources of plate and screen power. The basic triode amplifier in Fig. 4A is shown with a battery bias source; a battery-biased high-gain pentode preamplifier stage is illustrated in Fig. 7. Note how all ground returns are made to a single point to prevent

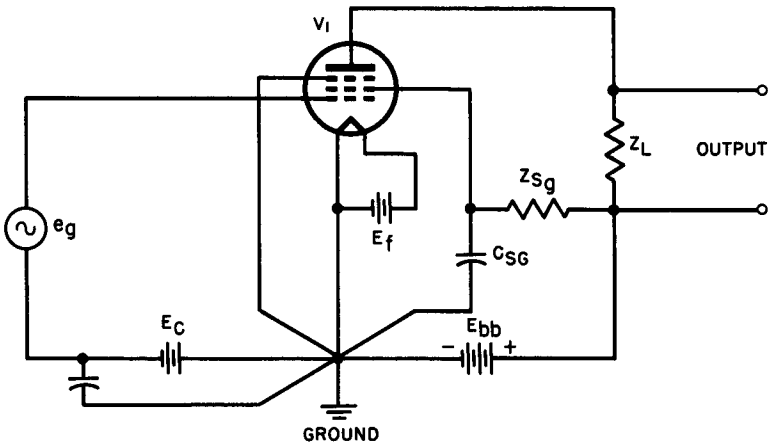

Fig. 7. Battery-biased high-gain preamplifier circuit.

the possible formation of ground loops which often cause instability or hum in high-gain amplifiers. Rectifier-filter systems of the correct voltage may, of course, be substituted for batteries in a-c equipment

Series-filament bias — Series-filament circuits frequently offer an opportunity to obtain grid bias without troubling to install resistors or separate batteries. We may take advantage of the voltage drops across the tube filaments, as illustrated in Fig. 8, to bias one or more amplifier grid.

The same current flows through each series filament in the example shown. These are standard 1.4-volt .05-ampere filament-type battery tubes that might be used in a three-way portable radio

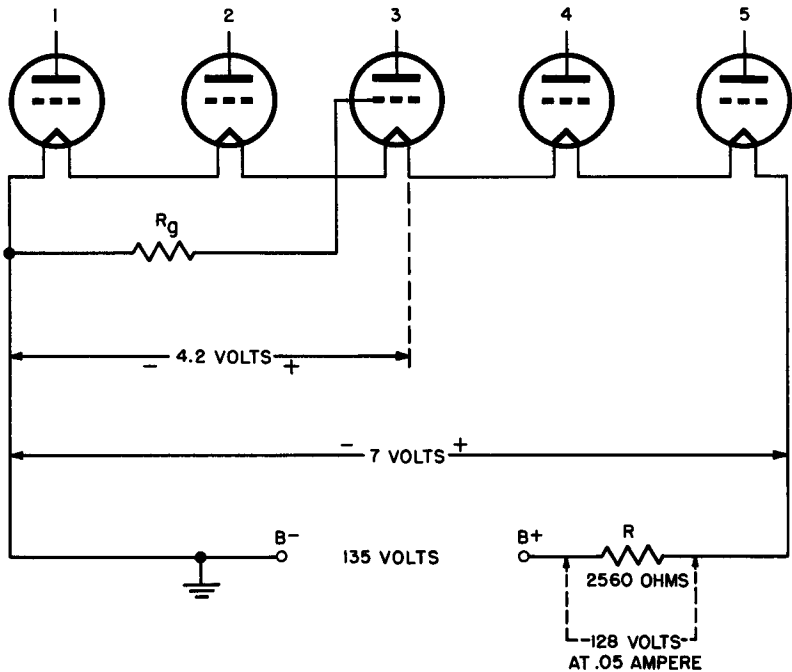

Fig. 8. Circuit using series-filament bias.

receiver. The standard method of energizing the filaments consists of connecting the series string across the rectified and filtered power supply — generally about 135 volts — in series with a suitable dropping resistor R . The value of R is such that a total of 7 volts appears across the five tube filaments providing each with 1.4 volts. Assume that one of the five tubes requires a negative grid bias of approximately 4 volts. If this tube is made No. 3 of the string, as shown, then its filament will be very close to 4 volts above ground at its negative end. Hence, its grid may be connected to ground through a suitable grid load R_g to provide the needed negative d-c grid bias. By selecting other points along the string in this manner, it is often possible to bias four of the five tubes satisfactorily without recourse to other more costly methods.

6. Review Questions

1. Explain how a resistor in series with the cathode return of an amplifier tube

produces negative grid bias. Include the reason for the cathode resistor and bypass capacitor.

2. Why is the screen grid of a pentode or beam tube maintained at a-c (signal) ground potential?
3. What series screen-dropping resistor is required to have 150 volts on the screen of a pentode that is supplied from a power source of 250 volts when the screen current is 2 ma?
4. Compute the voltage gain to be expected from a 6J5 triode operating at a plate voltage of 90 volts, a grid voltage of 0 volts, and working into a 10,000-ohm load resistor.
5. Calculate the resistance and dissipation rating for a cathode resistor which will bias a 6V6 beam tube for maximum signal conditions when the plate voltage is 180 volts.
6. What is the purpose of an equivalent circuit of an amplifier?
7. Explain why it is said that the plate current of a vacuum tube is always unidirectional even though the signal output is ac.
8. Why is the control grid of a triode amplifier generally made slightly negative with respect to the cathode?
9. Define amplification factor. Can a triode amplifier produce a voltage gain equal to its amplification factor? Explain.
10. Name and describe two popular grid-bias systems for low-frequency amplifier tubes.

Chapter 2

FUNDAMENTAL AMPLIFIER CONSIDERATIONS

7. Amplifier Criteria

Below are listed the principal criteria for evaluating the performance of an operating amplifier or specifying the characteristics of one still on the drafting board:

(a) *Voltage gain* — A complete amplifier system is necessarily designed to operate with more or less specific signal-input equipment. Whether the signal input is provided by a phono-cartridge, a microphone, or a radio receiver, the amplifier design must take into account the anticipated range of input voltages so that sufficient voltage amplification is made available. Although not always the case, voltage-amplifier stages usually provide the drive required by one or more power amplifier stages. Such a system cannot perform properly unless the overall voltage amplification is sufficient to provide the signal swing needed by the power-tube grids.

(b) *Power output* — An amplifier system may drive a loudspeaker or a group of speakers, a recording head, a modulator system, an ultrasonic transducer, or any number of other reproducers. The power requirements of the output device or devices must, of course, be met by the power-amplification portion of the amplifier system.

(c) *Fidelity of reproduction* — High-quality amplifiers must primarily be capable of linear operation: that is, as a first requisite the amplifier output waveform must be as close to that of the input signal as the state of the art permits. This specification must be realized over the entire frequency range for which the amplifier is intended. In other words, the *distortion* of the input signal must be held to a minimum.

(d) *Frequency response* — Much of the literature dealing with low-frequency amplifiers stresses frequency response. Good frequency response means equal amplification of all the individual

frequencies within the range covered by the amplifier system. Therefore, an amplifier with good frequency response provides equal voltage gain and equal power amplification of all input signals regardless of their frequency, within the limits established by the design and the application of the system. The usual phrase for this performance criteria is *flatness of response*.

(e) *Tone control* — The desirability of some form of tone control is more evident in audio amplifiers than in most other low-frequency systems. The acoustics of the room, the reproducing characteristics of a given phono-playback or microphone, and the individual tastes of the audience, almost invariably demand that the operator of the equipment be able to alter the frequency-response curve of the amplifier. Thus, high-fidelity reproducing apparatus always incorporates various forms of *tone controls* such as treble and bass boost, treble and bass attenuation, presence controls, roll-back methods, etc. Essentially, these modifications of the frequency response of recording or reproducing equipment may be classified as systems of *equalization*. Any network which accomplishes such modifications may be called an *equalizer*. There is a common tendency among students to confuse the terms equalizer, attenuator, and filter. For the moment, it is adequate to differentiate between these by means of simple verbal definitions:

Attenuator — An entirely resistive network which can attenuate a given signal without introducing phase or frequency changes.

Equalizer — A network comprising resistances and reactances which gradually modify the frequency response of an amplifier system.

Filter — A network usually purely reactive, although resistances are sometimes encountered.

A filter network is introduced into an amplifier system to discriminate sharply between different frequencies. Filters (Fig. 9) are commonly divided into four general categories.

(1) High-pass filters which permit unattenuated passage to the higher frequencies of the spectrum while reducing the intensity of the low frequencies to an extremely small figure.

(2) Low-pass filters which have the opposite effect.

(3) Band-pass filters which cause little or no attenuation to frequencies in the mid-range but cut out the higher and lower ends of the band under consideration.

(4) Band-reject or single frequency-reject filters in which a narrow band of frequencies or a single frequency is removed to im-

LOW-FREQUENCY AMPLIFIERS

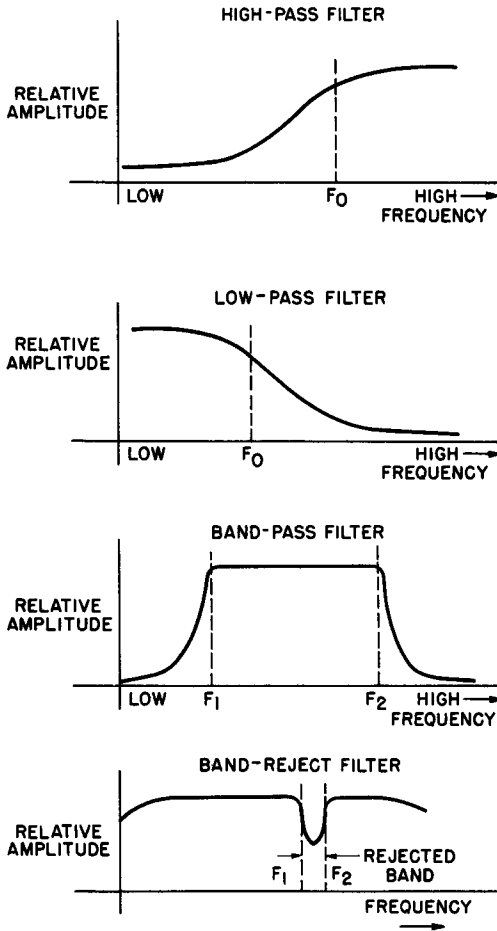

Fig. 9. Relative amplitude v. frequency curves for different filter types.

prove the reproduced sound. A scratch filter on a phono-playback or a 10-kc filter on a high-fidelity tuner are examples of band-reject filter systems.

(f) *Noise and hum level* — Vacuum tubes and the components used in amplifiers tend to produce noise voltages which are unrelated to the input signal and are not derived from it. The familiar hiss from a high-gain voltage amplifier working at or near top capacity, and other sizzling, crackling, or frying sounds, must be depressed below the point where it annoys the listener. Modern tubes and circuits have been perfected to the degree where noise is no problem as long as the equipment is operated within its ratings.

Proper design and level of operation usually eliminate a noise problem. When excessive noise exists, a defective part is generally to blame. The hum level of an amplifier must also be maintained below the audible level under normal operating conditions. Here again, well engineered circuits and components keep the hum inaudible.

(g) *Impedance matching* — The input and output conditions must permit the amplifier to work into and out of impedances for which it is designed. To carry this out, each stage of the amplifier must be equipped with an input-coupling device and an output-coupling device of the correct type and size. The complete amplifier is expected to be versatile in the sense that it can handle various types of input and output devices where impedances might be quite different. For instance, a given amplifier might be called upon to accept signals from high-impedance sources like crystal microphones and phono-playbacks on some occasions, and from low-impedance sources such as magnetic cartridges or audio transmission lines on others. Similarly, the amplifier may be expected to work into a loudspeaker output transformer or a transmission line of vastly different impedance simultaneously or at different times.

In the strictest sense, impedance matching refers to certain conditions which cause the *output impedance* of the generator (amplifier plate circuit) to be *equal* to the *input impedance* of the load that follows it. The power transferred to the load then becomes the largest possible value but, since equal powers are dissipated in equal impedances, the efficiency of transfer is only 50%.

It has become common practice to use the phrase "impedance matching" even when the output and input impedances are not equal, provided that the load has been selected to provide certain desirable results. For example, the load resistance of a class-A amplifier triode is generally chosen so that the distortion cannot exceed a given predetermined figure. Analysis of triode dynamic performance in connection with load lines demonstrates that for a maximum distortion of, say, 5%, the load resistance must be approximately equal to *twice* the plate resistance of the tube. For certain tubes that have an extremely low plate resistance (*e.g.*, the 2A3 for which $r_p = 800$ ohms), the load impedance may be even greater than twice the plate resistance. For example, the recommended plate load for a 2A3 is 2500 ohms as contrasted with its plate resistance of only 800 ohms. Figure 10 illustrates the difference

between *maximum power output* and *maximum output without intolerable distortion*. Note that maximum power output occurs when the load resistance exactly matches the plate resistance of the tube, but that for this condition the distortion level (point A) is excessive — almost 13%. As the load resistance is increased, both the power output and the distortion diminish. When the load resistance

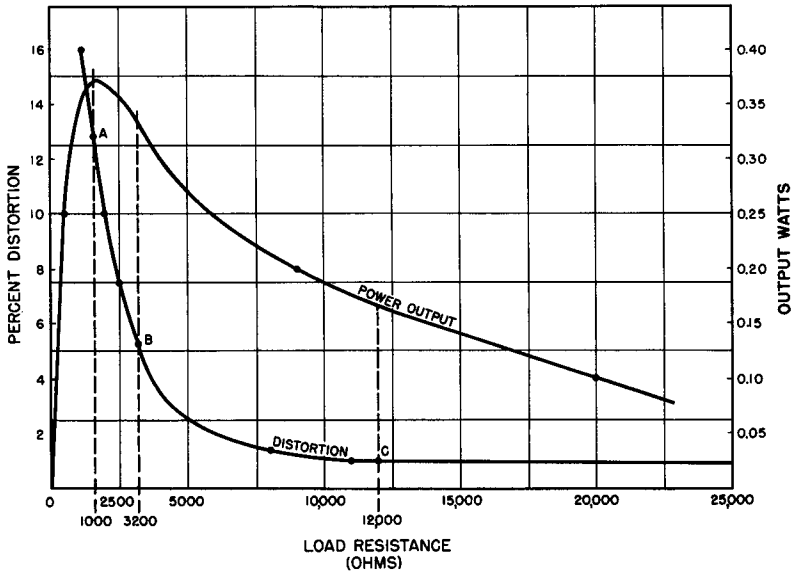

Fig. 10. Graph indicating curves of power output and percent distortion for various values of load resistances.

becomes 3200 ohms, the distortion drops to approximately 5% while the power output has decreased from 0.37 watt to 0.34 watt (point B). This is a rather insignificant loss of power output considering the great reduction in distortion.

Distortion may be reduced still further by raising the value of the load resistance above 3200 ohms. With a load of about 12,000 ohms (point C), the distortion has dropped to about the lowest value (1%) achievable in this particular circuit. For this situation, the power output is down to 0.17 watt, or less than half of the maximum power output possible.

Impedance matching (using the phrase in its broader sense; *i.e.* selection of load for predetermined behavior rather than equaliza-

tion of output and input impedances) also affects the frequency response of an amplifier.

8. Frequency Response

When discussing low-frequency amplifiers, particularly those intended for the audio range, some important characteristics of the human ear must also be considered. There is a *maximum* sound intensity above which the effects become painful, just as there is a *minimum* level below which the ear cannot detect sounds. These intensities depend upon the frequency to a great extent. At low levels, a change of about 23% in loudness* must occur before it will be audible to the normal ear. At greater intensities, the percentage is somewhat lower reaching a minimum of about 10% for very loud sounds.

The range of pressure to which the ear will respond is shown in Fig. 11. Note that the horizontal axis is marked off in frequencies ranging from 8 cycles to well over 32,000 cycles. Each division on the frequency scale is twice that of the one preceding it (in *octave* steps according to musical terminology). The vertical axis is spaced logarithmically and reads "dynes per sq. cm." (One dyne per sq. cm is roughly 4×10^{-7} lb/in².)

From this chart (Fig. 11), it is evident that frequencies above 20,000 cycles are not perceived as sound, nor are those below 20 cycles. Any frequency between these limits, however, is recognized as sound if its pressure is above the lower boundary marked "threshold of audibility." The upper limit, indicated as "threshold of feeling" shows the sound pressure at which the sensation of pain begins. Above this line, the sounds are *felt* rather than *heard*.

Frequency and *pressure* are the physical characteristics of sound. Our aural response to these are, respectively, pitch and loudness. Both of these responses of the ear and brain vary logarithmically with their stimuli. The difference in pitch between the sounds corresponds to the logarithm of the ratio of their frequencies. Similarly,

* Loudness, as measured by the Bell Telephone Co., is defined in terms of "sensation units." A sensation unit is defined as

$$SU = 20 \log p$$

where *p* is sound pressure in dynes.

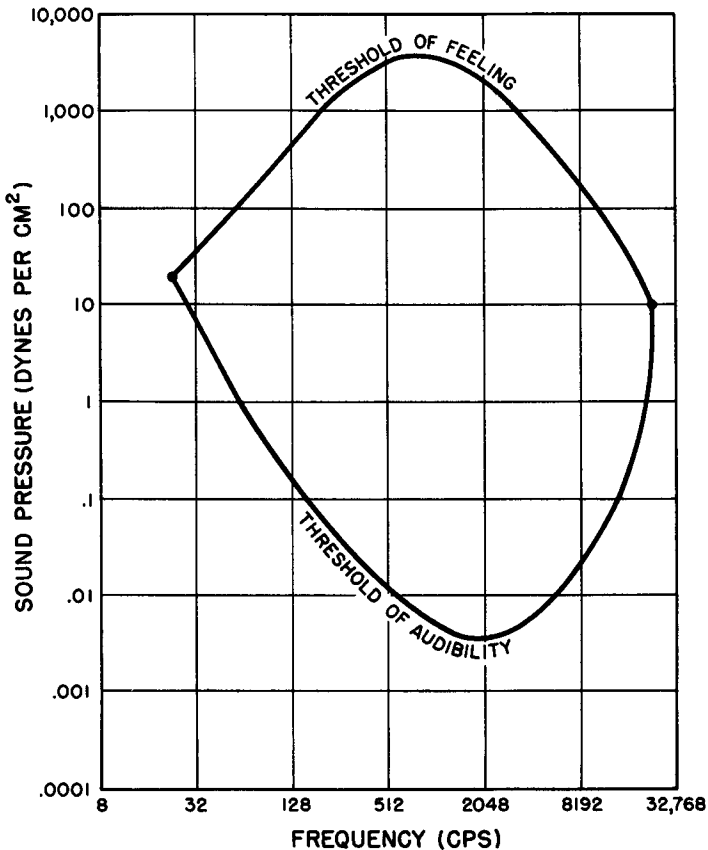

Fig. 11. Graph showing curves of sound pressure v. frequency.

the difference in loudness is proportional to the logarithm of the pressure ratio. In the case of loudness, the proportionality is not quite constant so that the constant-loudness lines are not truly horizontal.

Although sounds of different frequencies can be changed in intensity so that they sound equally loud to the ear, the power needed varies over wide limits. Any sound wave that lies within the shaded area can be heard as sound. If it falls above the threshold of feeling, it is felt as pain; if below the threshold of audibility, it cannot be sensed at all.

The curve of Fig. 12 indicates the variation of sound energy required to produce spoken sounds that seem to have the same loud-

ness to the average human ear. It is apparent from this curve that much greater sound power is needed at frequencies below 500 cycles. The ear is normally quite sensitive to sounds around 1000 cycles so that very little energy is required to produce tones of this frequency for the same degree of loudness. This curve is important in the study of output stages of low-frequency amplifiers for it shows that the loudspeaker will require a much larger amount of power from the output tube for these frequencies than for the higher ones. Thus,

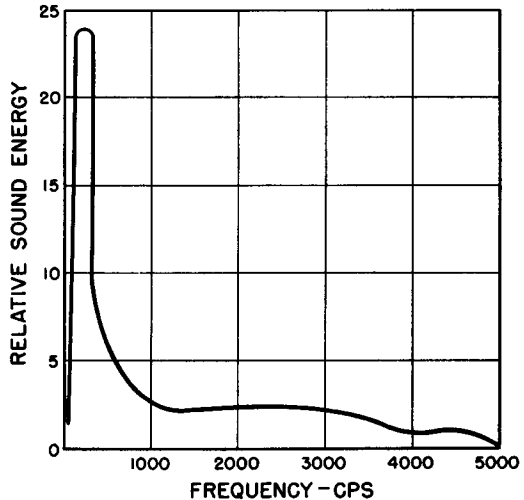

Fig. 12. Curve of relative sound pressure v. frequency.

we can conclude that, to produce the deep range, an amplifier will have to be equipped with an output stage capable of supplying greater power amplification than a similar amplifier that will not reach this low range.

The frequency response for a sound-reproducing system, or the response of any of its parts, describes how it handles various parts of the input signal that differ from each other in frequency. The term "handles" may refer to electrical amplification, to the conversion of mechanical to electrical energy (as in a microphone) or to the conversion of electrical to acoustical energy (as in a loudspeaker).

Any meaningful discussion of frequency response must cover two aspects: the *range* of frequencies handled, and the *uniformity* with which the unit or system responds to different individual frequencies. Information concerning range is useless without knowledge of uniformity. Since the latter depends upon the response of

the human ear to sound, it is necessary to learn how to handle the unit now commonly used to measure and compare sound intensities, *i.e.*, the decibel.

9. The Decibel

It has been determined experimentally that the response of the human ear is such that the loudness of a single note is not linearly proportional to the sound energy acting upon it, but is approximately proportional to the logarithm of the sound energy. For example, the sound energy of an orchestra playing a passage at its greatest volume is close to 1,000,000 times greater than the sound energy for the same passage when played at its softest volume. Yet, this same ratio of 1,000,000:1 has an apparent loudness ratio of only 60:1 as heard by the average human ear. In defining any unit to be used in the measurement of electrical or mechanical quantities related to the ultimate production of sound, it is therefore desirable to take this logarithmic response to the ear into account. In addition, by so measuring and comparing sound and its electrical equivalents, it is possible to obtain the total gains or losses in a circuit by ordinary arithmetic addition and subtraction if the unit selected is an exponential one. The *decibel* is such a unit.

A *bel* is defined as the ratio of the common logarithm of the output power of any electrical device (P_2) to the power input to the same device (P_1). That is:

$$\text{bels} = \log_{10} \frac{P_2}{P_1} \quad (10)$$

For ordinary power ratios encountered in audio work, the bel is too large a unit for convenient expression. The *decibel*, equal to 1/10 of a bel, is the unit more commonly employed. One decibel is 0.1 bel; conversely, 1 bel equals 10 decibels. Thus, the number of decibels between the level of P_2 and P_1 (both expressed in the same power units such as watts or milliwatts) is given by:

$$\text{decibels} = 10 \log_{10} \frac{P_2}{P_1} \quad (11)$$

If P_2 is larger than P_1 (that is, output power exceeds input power), then the electrical device has produced a *power gain* which

is evidenced by a positive sign in the answer; if P1 is larger than P2, signifying a *power loss*, a negative sign will appear before the answer.

Problem 3. If the power input to an amplifier is 1 watt and the power output is 2 watts, what is the gain in decibels (abbreviated *db*)?

Solution. P1 is 1 watt, P2 is 2 watts; hence:

$$\begin{aligned} \text{db} &= 10 \log_{10} \frac{2}{1} \\ &= 10 \times 0.301 \\ &= +3.01 \text{ db} \end{aligned}$$

Thus if the amplifier *doubles* the power of the original input, the power gain expressed in db is +3.01.

Problem 4. An amplifier has a power input of 0.002 watt and a power output of 0.2 watt. What is the db power gain?

Solution. P1 is 0.002 watt, P2 is 0.2 watt; hence:

$$\begin{aligned} \text{db} &= 10 \log_{10} \frac{0.2}{0.002} \\ &= 10 \log_{10} 100 \\ &= +20 \text{ db} \end{aligned}$$

In this case, the actual power has increased 100 times to yield a gain of 20 db.

Although the db is fundamentally a measure of power ratios, it may also be used to compare voltages and currents. From the power equations:

$$P = I^2Z \tag{12}$$

and

$$P = \frac{E^2}{Z} \tag{13}$$

where P is power in watts, I is current in amperes, E is voltage in volts and Z is impedance in ohms, expression for voltage and current ratios in db may be obtained as follows:

$$\begin{aligned} \text{db} &= 10 \log_{10} \frac{(I_2)^2 Z_2}{(I_1)^2 Z_1} \tag{14} \\ &= 20 \log_{10} \frac{I_2 \sqrt{Z_2}}{I_1 \sqrt{Z_1}} \end{aligned}$$

If the currents are measured in equal impedances, then the Z factors cancel out, leaving the simple form:

$$\text{db} = 20 \log_{10} \frac{I_2}{I_1} \quad (15)$$

If voltages rather than currents are handled, a similar equation is easily derived for the ratio of input to output voltage (or vice versa) as given in Equation 16. Note that this equation is valid only if the voltages are being developed across the same impedances.

$$\text{db} = 20 \log_{10} \frac{E_2}{E_1} \quad (16)$$

Problem 5. The voltage input from microphone to the grid resistor of an audio amplifier tube is .005 volt. (The grid resistor has a value of 250,000 ohms.) The voltage developed by the tube across its plate-load resistor of 250,000 ohms is 20 volts. What is the voltage gain of the amplifier stage in db?

Solution. Since the impedances are the same, we may use the simple form of voltage ratio equation:

$$\begin{aligned} \text{db} &= 20 \log_{10} \frac{20}{.005} \\ &= 20 \log_{10} 4000 \\ &= 20 \times 3.602 \\ &= 72.04 \end{aligned}$$

10. Decibel Reference Levels

The usefulness of the decibel in expressing power, voltage, and current ratios was demonstrated in Section 8. However, it is often desirable to express the power output of a microphone, a playback cartridge, or an amplifier in terms of db.

The power output of a microphone or any other transducer must be related to some specified input level, if the output rating is to be meaningful. The input to a microphone may be evaluated in terms of pressure or force, usually expressed in dynes per sq cm or *bars*, where a bar is equivalent to one dyne per sq cm of surface area. Therefore, unless otherwise stated by the manufacturer, output ratings of microphones are based upon db per bar of sound pressure. Similarly, a factor called "groove velocity" is generally used to state

the input level to phono-playback cartridges while the output is given in terms of db.

It is also essential that some fundamental reference level be chosen with which a power ratio may be setup. In the past, there have been many such "standard" reference levels — a situation which often led to confusion. In recent years, the number has been reduced to two: (a) The standard telephone company *zero level* has been selected as .006 watt or 6 milliwatts. That is, it is arbitrarily stated that 0 db = .006 watt. (b) The standard broadcast studio reference level is stated in terms of *volume units* or VUs in which 0 VU = .001 watt or 1 milliwatt (mw). The VU is computed on the same basis as the db since it is also formulated on a logarithmic scale. Normally, the telephone company reference level of 0 db = .006 watt is utilized in rating audio and other low-frequency amplifier equipment.

Problem 6. An amplifier delivers 10 watts to a loudspeaker. What is its output level in db based upon a zero level of 6 mw?

Solution. P2 is 10 watts, P1 is taken as .006 watt; thus, substituting in Equation 11:

$$\begin{aligned} \text{db} &= 10 \log_{10} \frac{10}{.006} = 10 \log_{10} 1666 \\ &= 10 \times 3.22 \\ &= 32.2 \end{aligned}$$

11. A Frequency-Response Curve

Returning now to the matter of frequency *range* and *uniformity* of response introduced in Section 8, experience shows that only a highly trained ear can recognize a difference of 1 db between two sound levels of the same frequency. For the average ear, a difference of at least 2 db is just barely audible for a single note. It is important to bear this in mind because it will help the reader remember that a 3-watts to 4.75-watts change of power is barely discernible to the listener, since this is a change of only 2 db. Power ratios are somewhat confusing because they give the impression of much larger effects than are actually apparent; herein lies the value of the db as a unit of sound measure and comparison. As an example of the meaning of uniformity and range of response, consider the curve of Fig. 13. This curve shows how much an audio system amplifies equal input voltages of different frequencies in the audio range. This

data is obtained by applying equal signal voltages of various known frequencies to the input and measuring the output voltage with a suitable instrument such as a vtvm or a cathode-ray oscilloscope. The results of such a test may then be plotted in the form of a graph with frequency along the X-axis and voltage amplification along the Y-axis.

Observe that the axes of the graph are not linear scales. Since the ear hears logarithmically, the graphs are plotted so that distances

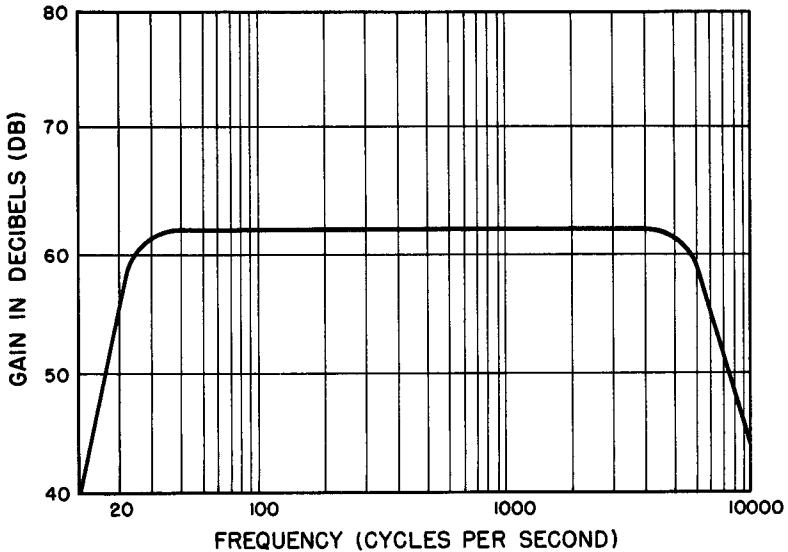

Fig. 13. A typical gain v. frequency response curve.

along the horizontal-frequency scale are proportional to the logarithm of the frequency. Similarly, the vertical scale is laid off in db with *uniform divisions* because the db is already a logarithmic unit.

An amplifier displaying a frequency-response curve such as that shown in Fig. 13 would be said to be "flat" from approximately 30 cycles to 5000 cycles. This means that, within tolerable limits, it has uniformity of reproduction over this range. For the reproduction of speech, such an amplifier would be more than adequate. It is generally agreed among acoustic authorities, however, that a "flat" range of 40 to 15,000 cycles is required for perfect or near-perfect apparent fidelity in the reproduction of orchestral music. It is too much to expect of any amplifier system that absolute flatness can be obtained over the entire range of operating frequencies. Thus, the

term "flat" does not imply this kind of perfection. If the response curve does not deviate vertically by more than 2 or 3 db overall, the system's behavior may be regarded as near-perfect.

There are several results that may occur with nonuniform reproduction. Excessive volume in a particular section of the sound spectrum can produce tinniness or boominess, depending upon the frequencies that are accentuated. The presence of sharp peaks in the response curve, usually representing a resonant condition, mean that *hangover* or *ringing* will be present. These effects cause the sound to become "muddy" and lose distinctness; in addition, the listener generally has trouble distinguishing between different low-frequency pitches. Resonant peaks often cause emphasis to be placed on undesirable noises such as turntable rumble or record scratch.

12. The Fletcher-Munson Contours

In 1933, two investigators in the field of acoustics demonstrated that our impression of loudness depends not only on the amplitude of the sound wave, but also on other elements. They showed, in particular, that sound in the lower-treble range of 3500 cycles and thereabouts appeared to be much louder than sound of the same amplitude in other parts of the spectrum. Thus, if the frequency scale is swept by a tone that rises continuously in frequency but maintains the same amplitude, the loudness or apparent amplitude would increase to a maximum at 3500 cycles and then drop off once more.

This fact in itself does not have any real value for the person listening to reproduced music. In some cases, it may describe the relative nuisance values of different forms of noise. Regardless of the improperly weighted interpretation we make of acoustic reality, we make the same interpretation in the concert hall as we do in our living rooms; so, essentially, this result as published by Fletcher and Munson holds little interest for us from a practical point of view.

These investigators, however, also found that the effect just described takes place in varying degrees, and that the extent to which it occurs depends upon the overall sound level. For very loud sounds, the decrease in apparent sound volumes below 3500 cycles is hardly discernible. As the sound level drops, the effect becomes more and more marked in this range. Above 3500 cycles, the change

in apparent loudness remains relatively constant (within 2 or 3 db) regardless what the overall sound level is.

Figure 14 shows these loudness contours. Each curve plots the sound amplitude required to produce the same perceived or subjective loudness at different frequencies of the sound spectrum. It is evident that normal loss in the bass end becomes progressively larger as the overall sound level diminishes.

To aid in the interpretation of these curves, consider a practical example. Suppose that an orchestra plays a passage in which frequencies around 200 cycles (bass) appear often and that the selec-

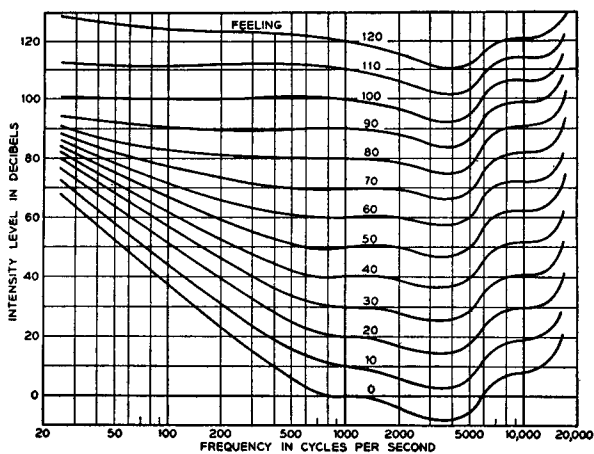

After Fletcher-Munson

Fig. 14. The Fletcher-Munson contours.

tion is being rendered at an overall level of about 100 db in the concert hall. Follow the contour that lies along the 100 db abscissa and notice that it remains almost perfectly constant throughout the lower-frequency range right up to the midrange value of 1000 cycles. Thus, if an amplifier remains flat from 1000 cycles down to 20 cycles at a 100-db level, the reproduction of this selection would be perfect. This level, however, is excessively loud for living-room or even small-auditorium use; more than likely, the reproduction level will be around 50 db.

Referring again to the contours, find the 50-db abscissa at 1000 cycles and follow the curve to the left until you reach 200 cycles. Observe how the curve rises to 60 db at 200 cycles. This means that the amplifier, if flat between 1000 cycles and 200 cycles, would provide

a reproduced rendition in which the sound level *would drop a full 10 db at 200 cycles compared to the level at 1000 cycles*. Since it was initially assumed that the orchestra level was maintained constant at approximately 100 db, it is clear that this "flat" amplifier would have very poor fidelity indeed at the lower frequencies.

To restore the original balance of apparent loudness for different frequencies at low-volume levels, it is customary to introduce *bass boost* in high-fidelity amplifiers. As a rule, such tone control is coupled to the volume setting either automatically or manually. When a volume control and bass-boost control work together, the adjustment is generally referred to as a *loudness control*.

13. Review Questions

1. Explain the difference between attenuation, equalization, and filtering.
2. What frequency range must receive equal amplification if the amplifier in question is to be considered flat for the discriminating ear?
3. In a certain circuit there is a loss of 25 db. What power ratio corresponds to this decrement?
4. A certain amplifier has 0.5 volt applied to its input resistance of 10,000 ohms. Across its output resistance of 5000 ohms appears a voltage of 40 volts. Compute the power gain and voltage gain, both in db.
5. An orchestra plays a musical passage at a constant level of 90 db. This music is reproduced by an amplifier at 60 db. How many db of increased amplification are required at 50 cycles (as compared with 1000 cycles) to produce the same relative loudness for both frequencies at the reproduced level?
6. Describe the Fletcher-Munson contour curves and explain the information derived from them.
7. Why is a variation of 1.5 db along a frequency response curve of little importance?
8. Define the decibel. Explain why it is so important in audio work.
9. What is meant by impedance matching? What are the effects of impedance mismatches?
10. Name the important amplifier criteria and discuss each one briefly as to meaning and importance.

Chapter 3

LOW-FREQUENCY VOLTAGE AMPLIFIERS

14. Summary of Tube Characteristics

The meaning of amplification factor (μ) and dynamic plate resistance (r_p) were mentioned in Chapter 1 in connection with the calculation of the voltage amplification of a tube. It is the purpose of this section to define all the common tube "constants" of characteristics briefly, and to supplement these definitions with explanations and examples where necessary.

Amplification factor (μ) — Amplification factor is the ratio between the plate voltage change required to produce a certain plate current change and the grid voltage change required to produce the same change in plate current, but in the opposite direction. In effect, by successively changing the plate and grid voltages to the correct extent, the plate current can be held constant. If the plate voltage is made more positive, then the grid voltage must be increased negatively for a constant plate current; hence a minus sign sometimes precedes the mathematical definition of μ .

$$\mu = - \frac{dE_b}{dE_g} \quad (I_b \text{ constant}) \quad (17)$$

Dynamic plate resistance (r_p) — The dynamic plate resistance of a tube is the resistance the plate circuit offers to a small increment of plate voltage. Thus, when an increase of plate voltage dE_b causes an increase in the plate current dI_b , the plate resistance may be expressed as:

$$r_p = \frac{dE_b}{dI_b} \quad (E_g \text{ constant}) \quad (18)$$

In this connection, it is important to observe that the dynamic plate resistance is not the ratio of the total plate voltage to the total plate current.

Problem 7. The plate current of a tube is 4.5 ma when the plate voltage is 90 volts. When the plate voltage is dropped to 40 volts, the plate current diminishes to 0.9 ma. What is the plate resistance of the tube?

Solution. Substituting in Equation 18:

$$\begin{aligned} r_p &= \frac{dE_b}{dI_b} \\ &= \frac{50}{.0036} \\ &= 13,900 \text{ ohms approx.} \end{aligned}$$

Plate resistance is not absolutely constant over all possible ranges of plate and grid voltages. This parameter for a given tube is usually specified at a certain plate and grid voltage by the manufacturer.

Transconductance (g_m) — Transconductance is defined as the ratio of a change of plate current to the change in grid voltage which produces it, plate voltage remaining constant. Thus:

$$g_m = \frac{dI_b}{dE_g} \quad E_b \text{ constant} \quad (19)$$

where g_m is in mhos. Transconductance, which is expressed in micromhos for the typical vacuum tube, is a rough measure of a tube's merit. This is apparent when we consider what happens when Equations 17, 18 and 19 are combined:

$$g_m = \frac{dI_b}{dE_g} = \frac{dE_b}{\frac{r_p}{\frac{dE_b}{\mu}}}$$

Thus,

$$g_m = \frac{\mu}{r_p} \text{ mhos} \quad (20)$$

Equation 20 thus indicates the extent to which a high amplification factor and low plate resistance are realized, hence g_m provides some indication of the merit of the tube as an amplifier.

Problem 8. A 6AC7 pentode is a specially designed high-gain amplifier tube having a transconductance of 9000 μ mhos and a plate resistance of 1,000,000 ohms. What is the effective amplification factor of this tube?

Solution. Solving Equation 20 for μ , we have:

$$\begin{aligned}\mu &= g_m r_p \\ &= 9 \times 10^{-3} \times 10^6 = 9000\end{aligned}$$

This is a startlingly large figure for amplification factor. Normally, of course, pentodes are not assigned amplification factors because plate current is relatively independent of plate voltage due to the shielding action of the screen grid in these tubes. It is still illuminating, however, to go through a problem such as that given above so that one may see why amplification factor is more or less meaningless when applied to pentodes and beam tubes. In the last analysis, possible voltage gain is far more important to the user of the tube than is amplification factor. Referring back to Equation 8 in Chapter 1, it is evident that the voltage gain of the 6AC7 can never approach its amplification factor because of its high plate resistance. Actual voltage gains available from this tube may reach about 400 in suitable circuits, seldom more.

15. Voltage Gain of a Pentode

The general equation for voltage gain or amplification (Equation 8) is repeated here for convenience:

$$A = \frac{\mu Z_L}{r_p + Z_L}$$

Low-frequency voltage amplifiers are usually operated with a purely resistive plate load, so this equation is more conveniently expressed:

$$A = \frac{\mu R_L}{r_p + R_L} \quad (21)$$

If the fraction $R_L/r_p + R_L$ becomes larger, amplification increases until, as the fraction approaches unity as its maximum value, the voltage amplification approaches μ . This theoretical maximum can never be realized in practice because R_L would have to be infinite (an open circuit) in order for $R_L/r_p + R_L$ to become unity. In practice, the voltage amplification is made to approach more closely to the theoretical maximum value, *i.e.* the amplification factor, by raising the load resistance until such a point is reached that the plate potential of the tube becomes too low to allow the tube to function

properly. Even with transformer coupling between tubes we can obtain actual amplifications that are quite sizeable with respect to the maximum value. For example, if the resistance of the load is made three times larger than the plate resistance, then the load resistance is $3/4$ of the total resistance while the plate resistance is $1/4$ of the total resistance. In this situation, the voltage gain is about 75% of the μ of the tube.

Turning our attention to the pentode, we see that its high plate resistance changes the situation somewhat when the tube is compared with the triode. Placing a normal load resistance in series with a high plate resistance makes little difference in the variations of plate current. Consider, for example, the recommended load resistance for a type 6AU6 pentode: the plate resistance of this tube is 1 megohm and, for a voltage gain of over 300, a 0.1-megohm load resistor is suggested. Thus, the load resistance is only 10% of the value of the plate resistance and will have very little effect upon the plate-current variations. From this, it follows that the transconductance g_m will be only slightly affected by the addition of a normal load resistor in the plate circuit (since g_m is a measure of plate-current variations with given grid-voltage changes) so that the g_m of a high-gain pentode may be considered to remain constant with or without a load resistor added. This means that for the calculation of the voltage gain obtainable with pentodes it is only necessary to multiply the transconductance by the value of the load resistance. Thus, for a pentode:

$$A = g_m R_L \quad (22)$$

This equation may be mathematically justified as follows:

From Equation 8,

$$A = \mu \frac{R_L}{r_p + R_L}$$

From Equation 20,

$$\mu = g_m r_p$$

Combining these equations:

$$A = g_m R_L \frac{r_p}{r_p + R_L}$$

As r_p is made increasingly larger (as it is in the pentode) the value of the fraction $r_p/r_p + R_L$ approaches more and more closely to

unity. Compared to the product $g_m R_L$ for a pentode, this fraction becomes insignificant for practical purposes and may be dropped without seriously affecting the precision of the equation.

Problem 9. Calculate the voltage gain of a 6AU6 pentode operated under such conditions that its transconductance is $5200 \mu\text{mhos}$ with a load resistance of $100,000 \text{ ohms}$.

Solution. The high plate resistance of this tube (1 megohm) makes Equation 22 suitable. Hence:

$$\begin{aligned} A &= g_m R_L \\ &= 5200 \times 10^{-6} \times 0.1 \times 10^6 \\ &= 520 \end{aligned}$$

Note that this gain is given for a single uncoupled stage. That is, it is the amplification as read by a theoretically perfect vacuum-tube voltmeter having an infinite input impedance. In practice, substantially lower gains are actually obtained as a result of the loading effect of the device or stage into which the pentode is coupled. For example, the actual measured gain of the circuit shown in Fig. 15, all things considered, is given by the manufacturer as 168.

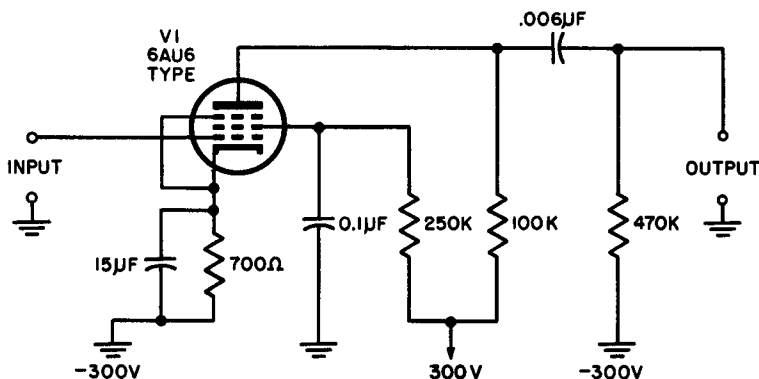

Fig. 15. Schematic diagram of a practical amplifier circuit using components recommended by the tube manufacturer.

16. Using Load Lines

Applying the load-line technique to amplifier circuits provides information about tube behavior in graphical form. Specifically, a load line drawn into a family of plate-characteristic curves enables the user to determine complete sets of data concerning quiescent plate currents for various grid voltages at given supply voltages. In

addition, the actual voltage amplification of an amplifier is quickly obtainable by this method.

There are several ways to draw a load line. One of the simplest methods is based upon the fact that the entire source voltage (d-c) is divided between the tube internal resistance (r_p) and the load resistance (R_L).

First consider what would happen if the tube were assumed to act as a short-circuit. In this case, the entire source voltage would appear across the load and the current flowing is simply the voltage divided by the resistance as given by Ohm's law. Thus, the first load-line coordinate is determined by the equation:

$$I_b = \frac{E_{bb}}{R_L} \quad (23)$$

For example, let us assume that the supply voltage (Fig. 16) is 300 volts for a typical triode voltage amplifier and that the load resistance is 20,000 ohms. Thus, from Equation 23:

$$\begin{aligned} I_b &= \frac{E_{bb}}{R_L} = \frac{300}{20,000} \\ &= 0.015 \text{ ampere} = 15 \text{ ma} \end{aligned}$$

Since all of the supply potential is now across the load, the plate voltage on the tube is zero, and the coordinate for the load line is (0), (15). This is Point A in Figure 16.

Second, assume that the tube is in a state of plate-current cutoff. With zero plate current flowing through the load, there is no voltage drop across R_L , hence the full supply voltage now appears across the tube as plate voltage. The second load-line coordinate, therefore, is (300), (0) and is shown as Point B in Fig. 16.

Both of these steps are evident when one realizes that the potential between the plate and cathode of a tube depends upon both the magnitude of the source voltage and the magnitude of the current in the load resistor. It follows from simple series-circuit considerations that:

$$E_b = E_{bb} - I_B R_L \quad (24)$$

where E_b is quiescent plate voltage (between plate and cathode), E_{bb} is source voltage, I_B is quiescent plate current, and R_L is load resistance. This equation is the same as Equation 2 in Chapter 1, rewritten to include the factors which give rise to voltage across the

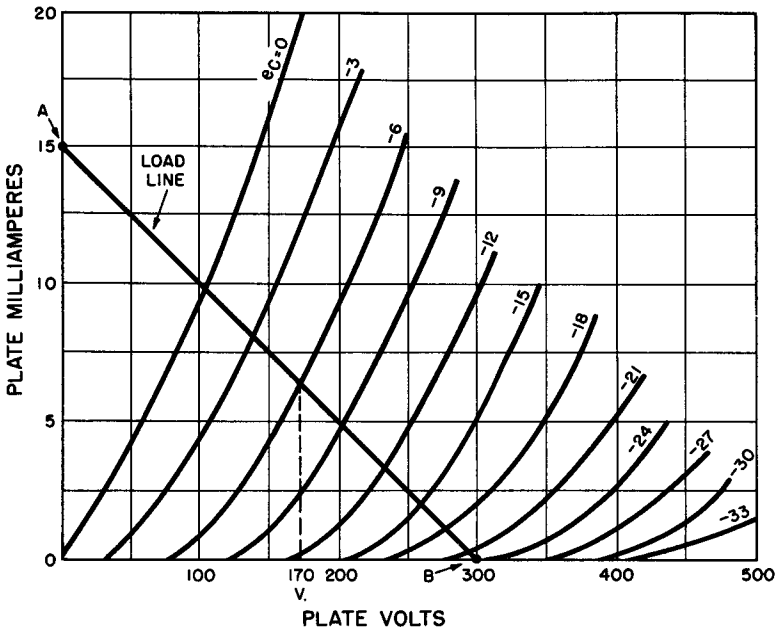

Fig. 16. Graph describing load-line construction.

load. It is evident that the two coordinates of the load line may be obtained in two steps: (1) set E_b equal to zero and solve for I_b , and (2) then set I_b equal to zero and solve for E_b .

The load line provides the means for determining the quiescent plate current, plate voltage, and voltage amplification of the tube at any selected value of grid bias.

Problem 10. Assuming a grid bias of -9 volts, find the quiescent plate current I_b , the quiescent plate voltage E_b , and the voltage amplification A .

Solution. Tracing the load line and the -9 -volt bias line to their intersection in the plate-characteristic curves, we find that I_b is 5 ma. This plate current causes a 100-volt drop across the load resistor (300 volts to 200 volts) leaving a quiescent plate voltage E_b of 200 volts. To find the voltage amplification, it is necessary to assume a small change of grid voltage (due to some signal input) and determine from the load line the change in voltage across R_L . On this particular graph, 3 volts constitutes a convenient change in grid voltage. Thus, going from -9 to -6 for a 3-volt change, we note that the plate voltage changes from 200 volts to 170 volts, a difference of 30 volts. This gives a ratio of $30/3$ or $10/1$ output to input; hence a voltage amplification of 10.

The foregoing example illustrates the role played by the load line in determining voltage gain for either low-frequency signal input or d-c input as would be encountered in relay problems in which a tube is used as a d-c amplifier.

17. Distortion in Amplifiers

Three forms of distortion of the original input signal may be present in voltage amplifiers.

(a.) *Frequency distortion* — An amplifier that does not provide the same gain at all frequencies is said to have frequency distortion. This type of distortion is primarily a function of the type of coupling used between cascaded stages, or between input device, amplifier, and reproducing device. It is not true, however, that all amplifiers are designed to have minimum frequency distortion; audio amplifiers are, perhaps, when frequency gain controls are omitted from consideration, but not amplifiers designed to separate signals on the basis of their frequency. Such amplifiers are encountered in communications receivers, television receivers, radar equipment, and countless other industrial applications.

(b.) *Harmonic or amplitude distortion* — The tone produced by a tuning fork is often called a “pure tone” since the sound produced consists of a single frequency. If a pure tone signal is to be amplified, and is to remain pure, all amplification must be strictly *linear*. In this connection, the term linear refers to an amplification process in which equal changes in input voltage result in equal changes in output voltage. Linearity of performance in a single amplifier stage may be determined from the load line. For instance, the tube illustrated in Fig. 16 provided an output voltage change of 30 volts for a grid-bias change of 3 volts when the latter was changed from -9 to -6 . It is a matter of minutes to find out whether this ratio holds up and down the load line. The table accompanying Fig. 16 provides the amounts.

The linear region of this tube is seen to be between -3 and -15 grid volts. Any grid signal that does not vary beyond these limits when the tube is operated with a plate load of 20,000 ohms and a supply voltage of 300 volts will thus be linearly amplified. The best amplifiers approach linear performance closely, but in all cases some new frequencies are generated that are multiples of the input tone. This is called *harmonic* or *amplitude* distortion. From the

standpoint of hearing, the most objectionable harmonics are the 2nd, 3rd, and possibly the 5th and 7th, for the two-fold reason that these harmonics are usually strong enough to be heard and they are low enough to appear within the audible region.

Although the linearity of a tube may be studied from its plate characteristics as in Table I, it is easier to see the effects of non-linearity from the *dynamic-transfer characteristic curve*. Such a curve is obtained by plotting plate current against grid voltage and may be obtained directly from the plate characteristics by assuming a fixed supply voltage and determining the coordinates of plate current for various values of grid voltage. Figure 17 is the dynamic-transfer characteristic of the same tube whose plate curves are shown in Fig. 16. If the tube circuit is arranged so that the negative grid bias is 6 volts, and the magnitude of the input signal is controlled so that it swings 3 volts plus and minus with respect to the idling bias (6 volts peak-to-peak), the resulting plate current will vary in almost exactly the same waveform as the input signal. If the load is resistive, the output voltage will then also follow the same waveform. Even though the transfer characteristic has slight curvature between these input limits, the linearity of the output voltage is quite acceptable.

TABLE I
GRID VOLTAGE — PLATE VOLTAGE RELATIONSHIPS

<i>Grid Voltage</i>		<i>Output Voltage</i>		<i>Change of Output Voltage for equal changes of input voltage</i>
<i>from</i>	<i>to</i>	<i>from</i>	<i>to</i>	
0	— 3.0	107	140	33 volts
— 3.0	— 6.0	140	170	30 volts
— 6.0	— 9.0	170	200	30 volts
— 9.0	—12.0	200	230	30 volts
—12.0	—15.0	230	260	30 volts
—15.0	—18.0	260	280	20 volts
—18.0	—21.0	280	295	15 volts

(25—27)

If the grid bias is now changed, however, to —15.0 volts with the same signal input, the resulting waveform contains amplitude distortion as illustrated in Fig. 18A. This form of over-bias dis-

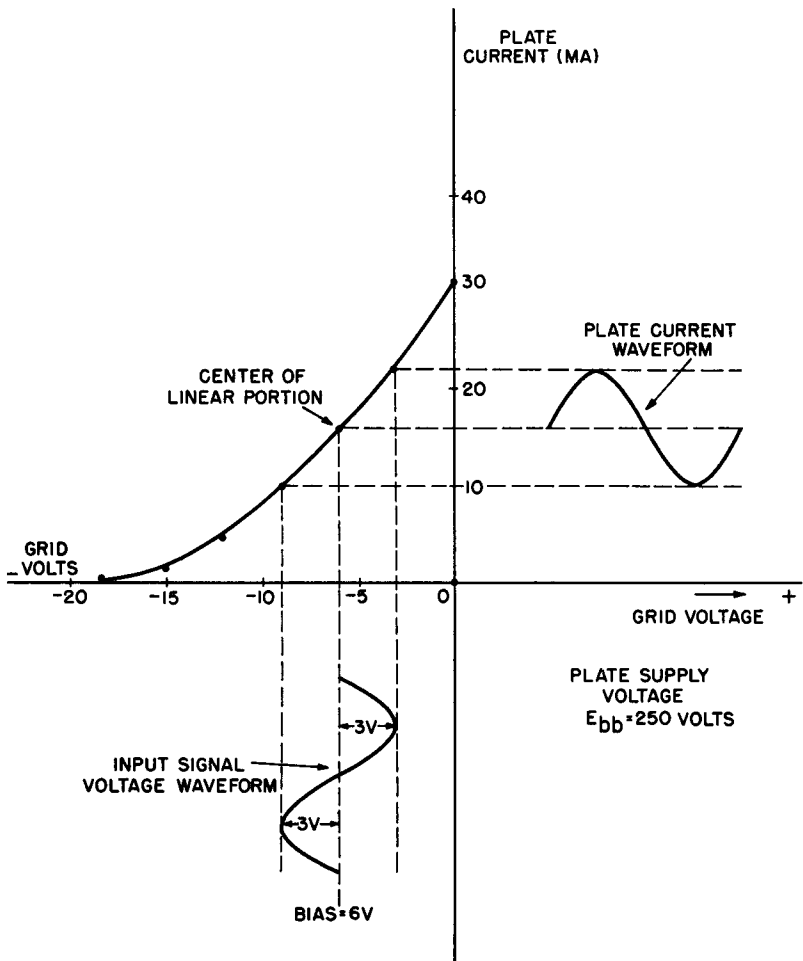

Fig. 17. Dynamic transfer characteristic curves. The tube is biased for minimum distortion.

tortion produces a flattening of the negative peaks of the resulting plate current. Under these conditions, the amplifier output will contain frequency components such as harmonics that are not present in the input signal. A somewhat different distortion pattern is encountered when the signal-voltage amplitude is too great, despite the fact that the bias may be correctly set at the center of the curve. In this case, large positive input-voltage peaks may drive the grid into the conducting region, causing a flattening of the positive plate-

current peaks; at the same time, the negative input-voltage peaks may drive the tube to plate-current cutoff. This results in a clipping of the negative peaks as well.

If the bias is too small and the signal amplitude reasonable in size, only positive-peak flattening may be observed. Here, the positive input voltage causes the grid to be driven positive, grid current flows, and the plate current (on the peak) is reduced.

The waveforms obtained due to incorrect bias or improper drive are all classified as harmonically distorted since they may be

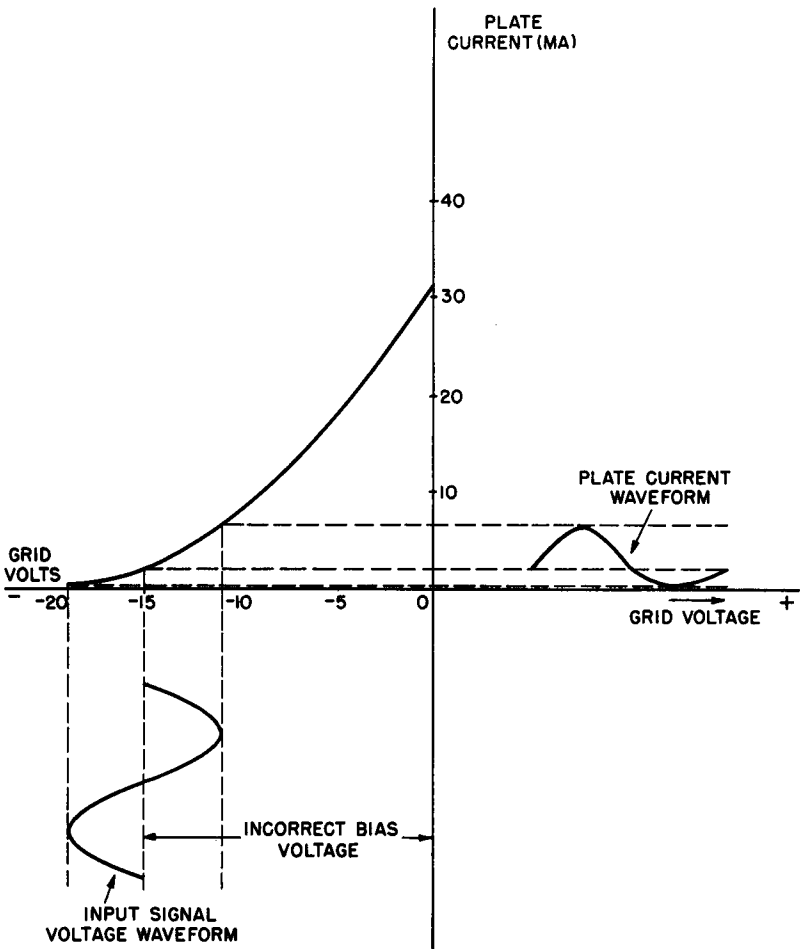

Fig. 18A. Incorrect bias produces amplitude or harmonic distortion.

analyzed into the fundamental frequency plus the various harmonics that would have to be added to the sinusoidal fundamental to produce the observed distortion pattern.

If the grid bias is now changed, however, to -15 volts with the same signal input, the resulting output waveform contains amplitude distortion as illustrated in Fig. 18A. The same effect will be encountered when the signal voltage amplitude is too great despite the fact that the bias may be correctly set at the center of the curve. In either event, the general result is a flattening of the negative half-cycle; this is the same as adding a second harmonic that lags the original pure tone by 90° .

Tests have shown that even a trained listener has difficulty detecting up to 2% harmonic distortion. (This percentage represents the ratio between the harmonic voltage and the total voltage. For example, if the fundamental voltage is 100 volts and the harmonic content of the whole output signal is 2 volts, then the total voltage will still be 100 with the harmonic portion representing 2% of the whole.) The average person can distinguish 5% distortion without too much difficulty while 10% is very objectionable.

(c.) *Phase distortion* — Most signal voltages are not even remotely sinusoidal but have a complex waveshape. This wave is composed of a fundamental sinewave and a group of harmonics. If the phase relations of the component parts of a complex wave are modified with respect to each other, the resulting waveshape will differ materially from the original. This delaying of certain components of the complex wave is called phase distortion. It is not especially serious in audio amplifiers but it must be corrected in other amplifiers where a wide band of frequencies is to receive more or less equal amplification.

18. Review Questions

1. What is the amplification factor of a tube in which a change of *grid voltage* from -2 to -4 volts produces the same effect on plate current as does a change of *plate voltage* from 240 volts to 200 volts?
2. The dynamic plate resistance of a certain triode is 10,000 ohms. If the plate voltage is increased from 200 volts to 250 volts, how much will the plate current rise?
3. Under certain operating conditions, a 6SF5 high-gain triode has an amplification factor of 100 and a transconductance of 1500 μmhos . What is its plate resistance?

4. Calculate the voltage gain of a 6SJ7 pentode operated under conditions such that its g_m is $1650 \mu\text{mhos}$ with a load resistance of 0.25 megohm .
5. Give a single equation that can be solved to find the two intercept coordinates of a load line.
6. Using the family of plate characteristics provided (Fig. 18B,) draw the load

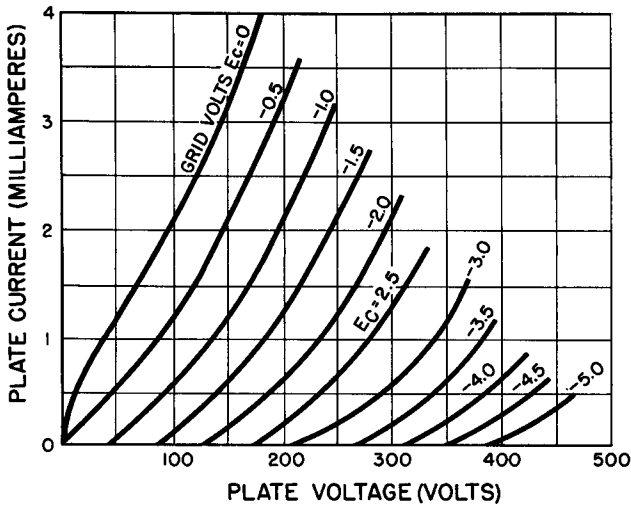

Fig. 18B. Family of plate characteristics of the 6AV6 type triode.

7. Compute the voltage amplification of the tube from the load line for these conditions.
8. Distinguish between frequency distortion and harmonic distortion. Which of these types of distortion is referred to when "flatness" of response is described?
9. Explain how the dynamic-transfer characteristic curve of a tube is plotted. Of what value is this type of graph?
10. Show that too high a negative bias has the same effect on the output waveform as too great a signal amplitude.

Chapter 4

SINGLE-ENDED POWER AMPLIFIERS

19. Function of a Power Amplifier

The ultimate function of any amplifier system is the conversion of electrical energy into some other form, usually mechanical in nature. Except for d-c amplifiers, the electrical energy is either alternating or pulsating. In audio amplifiers, conversion to sound from a loudspeaker is one possible objective; sometimes, the audio-frequency pulsations are converted to the mechanical movement of a recording head. In other cases, the electricity is converted into magnetic variations for tape recording. The amplified energy in d-c systems may be used to operate a relay or a recording stylus.

Whatever the reproduction mechanism may be, *power* is always required. In mechanics, power is defined as the rate of doing work; that is, the dimensions for power may be stated in terms of ft. lb/sec, dyne cm/sec, etc. It may be shown that the electrical unit of power, the *watt*, has the same dimensions and may be defined as *the power consumed when 1 ampere of electric current flows through a load where the emf is 1 volt.*

The function of a power amplifier is to supply as much electrical power as necessary to operate the load properly. In audio amplifiers, this power should be as nearly *distortionless* as possible. The amount of distortion in the output of a power amplifier used to run a motor is not so important.

Regardless of the service they are to perform, power amplifiers are designed with special characteristics that differ considerably from voltage amplifiers. These characteristics may be briefly described as follows:

(a) *Physical size* — Power tubes must be capable of dissipating quantities of heat larger than must voltage amplifiers. Their consequent physical size means that a larger radiating surface is pre-

sented to the air. In the case of very large power tubes designed to handle many kilowatts, forced-air cooling and water cooling are often utilized.

(b) *Amplification factor* — A power tube's amplification factor is much smaller than a voltage amplifier's of the same group (*i.e.*, triode, pentode, etc.). Gain is sacrificed to obtain large power handling ability.

(c) *D-c plate resistance* — Large amounts of power can be obtained only by large plate currents, assuming that the same power supply is used to operate the voltage and power amplifiers. This condition automatically demands that the d-c plate resistance of the power tube be sufficiently low to avoid large power dissipation in the tube itself. Since $P = I^2R$, then R must be small if I is large to avoid the generation of excessive heat in the tube envelope.

(d) *Power sensitivity* — Defined as the ratio of the power output to the square of the effective value of the applied sinusoidal grid voltage, power sensitivity is expressed:

$$\text{power sensitivity} = \frac{P_o}{e_g^2} \quad (28)$$

Thus, the greater the power sensitivity of a vacuum tube, the greater its power output will be for a given value of input voltage. Tube types differ substantially in this characteristic, as we shall see.

(e) *Plate efficiency* — The plate efficiency of an amplifier is the ratio of the a-c power output to the d-c power input to the plate circuit or

$$\text{plate efficiency} = \frac{P_o}{E_b I_b} \quad (29)$$

This characteristic, too, differs for various tube types.

(f) *Distortion* — Although distortion is not properly a *characteristic* of power tubes, it is mentioned here because of its importance in the overall performance of any amplifier system. Again, the amount of distortion due to the power tube depends upon the tube type as well as upon many other factors to be discussed later.

20. Amplifier Classes

There are many different ways in which amplifiers may be classified: (1) according to their loads, as in tuned amplifiers, un-

tuned amplifiers, transformer-coupled amplifiers, etc; (2) on the basis of frequency of response, as in d-c amplifiers, audio amplifiers, radio-frequency amplifiers, etc; (3) according to function, as in voltage and power amplifiers; (4) or in terms of their bias and other operating conditions.

The last-named classification is the one in which we are now interested. Our object here is to define and differentiate between these classes and discuss the reasons for favoring one type over another in low-frequency applications.

Class-A operation — A class-A amplifier is adjusted so that the plate current flows continuously throughout the cycle of the applied signal voltage. The term “adjustment” involves a number of circuit conditions: plate voltage, screen voltage in tetrodes and pentodes, grid bias, and signal input voltage. Figure 19 shows the operating characteristics of a class-A amplifier.

Observe specifically that the fixed-bias point (or operating point of the tube) has been selected so that it falls at approximately the center of the linear portion of the grid-transfer characteristic curve. Also, the signal swing applied to the input is sufficiently small to avoid carrying the grid voltage into either the upper or lower curvature. When these conditions are fulfilled, the plate-current waveform resembles the grid input-voltage waveform very closely. Voltage drop is proportional to current in any load whose impedance remains constant. Therefore, if the load has been properly designed and selected, the output voltage will also duplicate the input voltage.

Class-A amplifiers are characterized by excellent fidelity — provided that the operating point is chosen correctly as in Fig. 19 — and relatively low plate-circuit efficiency (Equation 29). In practice, an efficiency of 25% or thereabouts may generally be anticipated. Figure 19 discloses still another important characteristic: if the grid-driving voltage is held within the limits prescribed by the linear portion of the curve, the grid is never driven positive, hence it can never draw current. Thus, class-A amplifiers consume zero power in their grid circuits at low frequencies. However, since every amplifier tube, regardless of class of operation, must have a ground-return impedance, some power will be dissipated here. Therefore, in practice, the voltage amplifier that precedes the power stage need supply only a very small amount of driving power.

Class-B operation — A class-B amplifier is adjusted so that the plate current flows during approximately half of the input cycle.

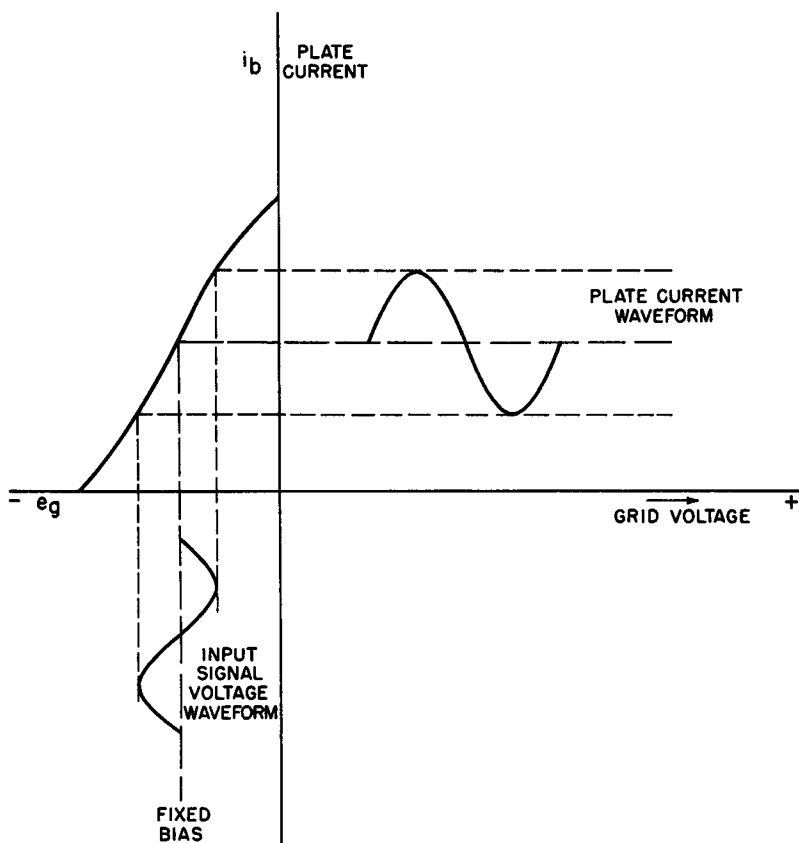

Fig. 19. Dynamic transfer characteristic, class-A operation.

This result is obtained by establishing the operating point of the tube at or near cutoff (Fig. 20).

The curve illustrating the operating conditions shows that a single tube operated in class-B cannot be used for audio or any other low-frequency amplification in which the output waveform must be a replica of the input waveform. Only one-half of the input voltage causes plate-current variations; the other half of the grid swing takes place below cutoff where the plate current cannot possibly be influenced since it cannot be less than zero. Single-tube class-B amplifiers can be used in linear radio-frequency amplifiers in which the "flywheel" action of the tuned circuit can supply the missing plate-current half-cycle. As we shall demonstrate, in certain applications

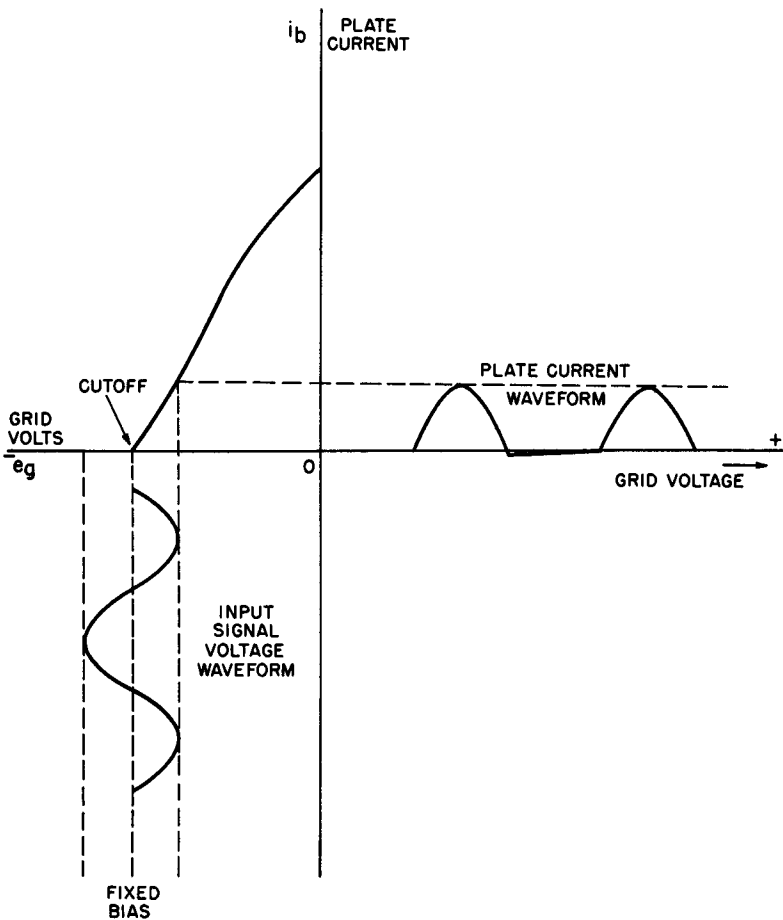

Fig. 20. Dynamic transfer characteristic, class-B operation.

a pair of tubes in class-B may be used in audio amplifiers if some distortion can be tolerated.

The important characteristics of class-B amplifiers are: medium-to-high plate-circuit efficiency (around 50%) and high distortion. To realize powers of the order of which class-B amplifiers are capable, it is customary to drive the grid into the positive region, thus consuming driver power. This makes a difference, of course, in the stage that precedes the power amplifier: ordinary voltage amplifiers can drive class-A amplifiers to full output, but class-B power stages require a power amplifier to provide the grid drive. Although the

reasoning that explains the higher plate-circuit efficiency of a class-B amplifier is beyond the scope of this book, it should be mentioned that this greater efficiency is indirectly attributable to the plate current flowing during a much smaller portion of the input cycle as compared to class A.

Class-C operation — A class-C amplifier is adjusted so that plate current flows during a small fraction (less than 180°) of the input cycle. To obtain operation of this nature, it is necessary to bias the amplifier tube well beyond cutoff — often as much as four times the cutoff bias value as shown in Fig. 21. Note that the plate waveform

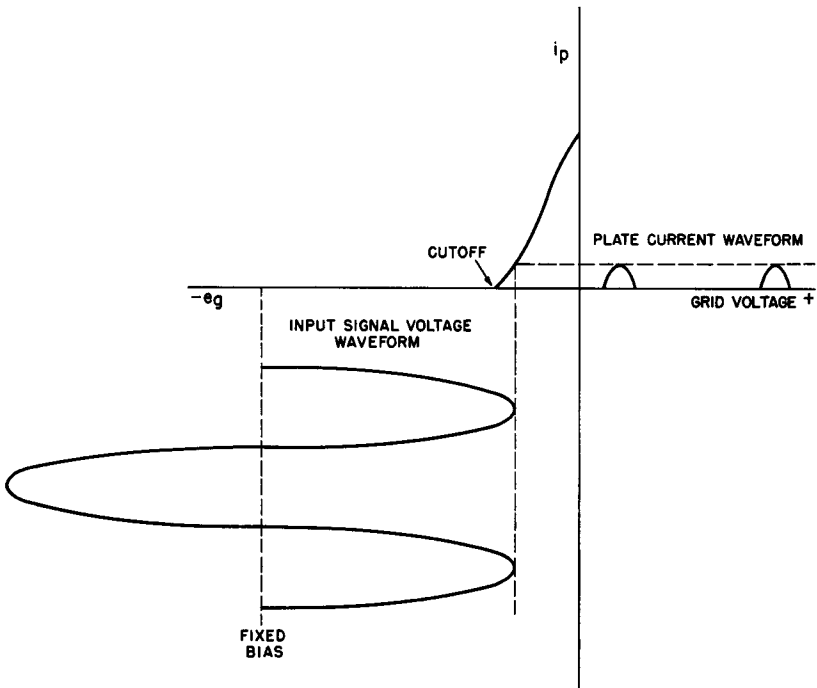

Fig. 21. Dynamic transfer characteristic, class-C operation.

has lost all resemblance to the grid input voltage. The existence of plate current in short pulses permits the efficiency of a class-C amplifier to be very high in comparison to other classes of operation. Properly adjusted class-C amplifiers are capable of plate efficiencies up to 85% provided that severe output distortion can be tolerated. This is true in radio-frequency amplifiers as used in transmitting equipment where, as previously stated, tuned-circuit flywheel action

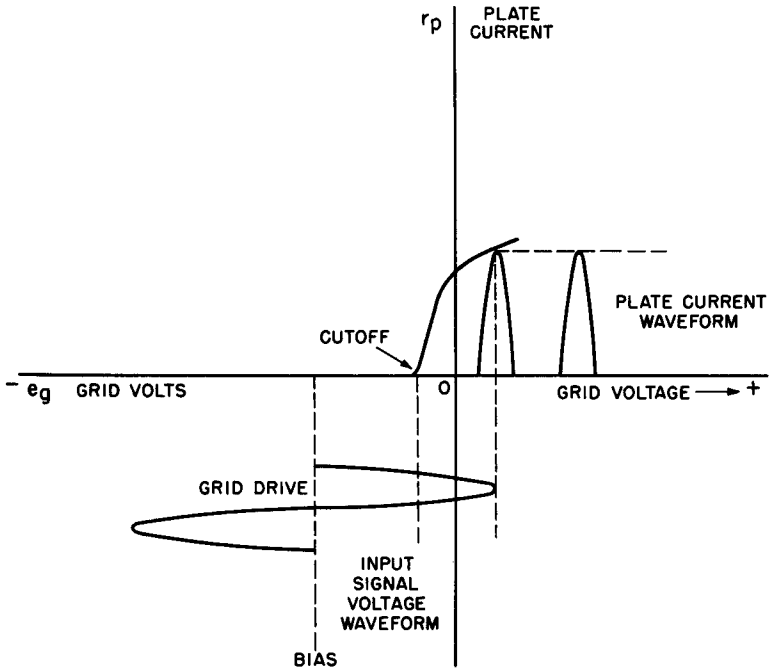

Fig. 22. Dynamic transfer characteristic, class-C operation with the grid driven positive.

supplies the missing portions of the wave. Obviously, class-C amplifiers cannot under any circumstances be employed in audio-frequency amplification. As in the case of class-B, the full potentialities of a tube in class-C can be attained only by using large driving power since the grid must be driven well into the positive region (Fig. 22).

21. Single-Ended Power Amplifiers

For the reasons given in the previous section, single-ended power amplifiers must be operated in class-A. Triodes, pentodes, or beam-power tetrodes find individual application in circumstances for which they are best fitted. For instance, triodes, have much less distortion but deliver less power per volt of grid signal. (That is, the power sensitivity of a triode is appreciably smaller than that of a pentode or beam-power tube). Any of the grid-bias systems may be used. Cathode biasing is most common. For purposes of compari-

son, the table presented here provides significant operating information for a popular beam-power tetrode (6L6) when used as a triode with screen grid connected to the plate and when used as a tetrode. Typical circuits for these conditions are illustrated in Fig. 23.

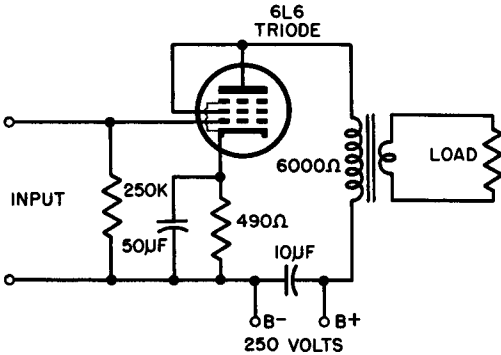
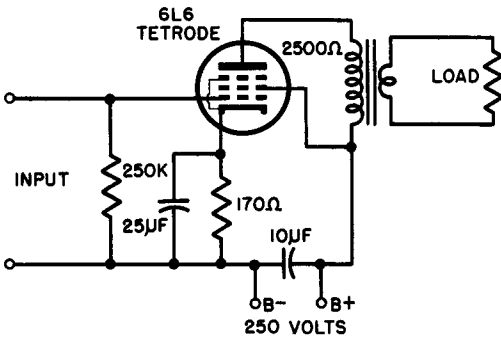

Fig. 23. The 6L6 connected (A) as a triode, and (B) as a tetrode.



Particular note should be made of the higher output, higher efficiency, higher power sensitivity, and greater distortion in the class-A pentode.

Any generator delivers the maximum possible power into the load when the latter equals the internal resistance of the generator. Thus, for vacuum-tube power amplifiers, this would imply that R_L ought to be made equal to R_p . While such a match will give maximum power output in the case of triodes, the resulting distortion is quite high. Attempting to match the plate impedance of a pentode

or beam-power tube with a load of equal value is quite impossible with normal tubes since multigrid tubes have such large plate impedances.

TABLE II
6L6 RATINGS AND CHARACTERISTICS

<i>Characteristics</i>	<i>6L6 Triode Connection</i>	<i>6L6 Tetrode Connection</i>
Plate voltage	250 volts	250 volts
Grid voltage	-20 volts	-14 volts
Zero signal cathode current	40 ma	80 ma
Signal swing (volts)	20 volts	14 volts
Plate resistance	1800 ohms	23,000 ohms
Load resistance	6000 ohms	2500 ohms
Transconductance	4700 μ mhos	6000 μ mhos
Maximum power output	1.3 watts	6.5 watts
Total harmonic distortion	6%	10%
Efficiency	12%	30%
Power sensitivity	.0065 watts/ grid volt ²	.065 watts/ grid volt ²

Tube manufacturers usually recommend in their data sheets a value of load impedance which compromises between reasonably good transfer of energy from tube to load and tolerable distortion levels. A rule of thumb that gives reasonably good results on a first approximation is:

Triodes — R_L is about 3 times R_p

Pentodes and Beam Power Tetrodes — R_L is about 0.1 times R_p

22. Calculating Power Output and Plate Efficiency

The calculation of power output and plate efficiency for power amplifiers in class A can be carried out by means of relatively simple equations based upon a purely resistive load. In most cases, however, the load is at least partially reactive; included in this category are loads such as loudspeakers, magnetic cutting heads, and magnetic recording-stylus drives. Although any precise formulations of ampli-

fier performance must take into account the presence of reactance in the load on a power amplifier, computations of sufficient accuracy for many practical purposes may be carried out by considering the load impedance to be purely resistive.

Thus, the power output (not counting harmonic content) of either a triode or a pentode may be obtained from:

$$P_o = \frac{(i_{b \text{ max}} - i_{b \text{ min}})^2 R_L}{8} \tag{30}$$

Problem 13. Find the power output of a power amplifier that has the plate characteristics shown in Fig. 24. Assume the following: plate supply = 250 volts, grid bias = -30 volts, peak signal input = 30 volts, load resistance = 1500 ohms.

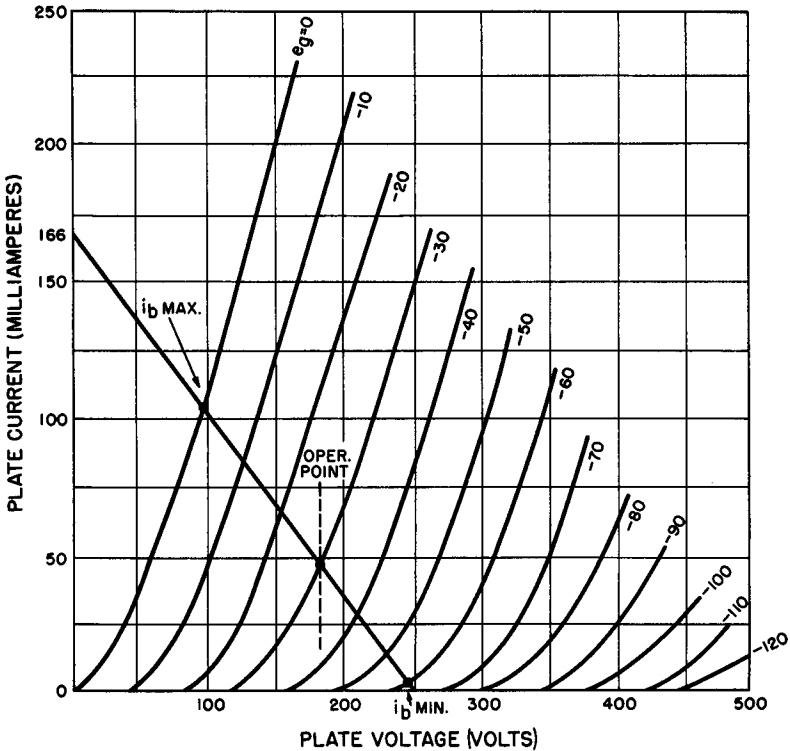

$$E_b = E_{bb} - I_b R_L$$

IF $E_b = 0, I_b = \frac{E_{bb}}{R_L} = \frac{250}{1500} = 166 \text{ ma}$ IF $I_b = 0, E_b = 250 \text{ VOLTS}$

Fig. 24. Plate characteristic used in problem 13.

Solution. Draw in the load line for the conditions given as shown in Fig. 35. Since the peak input is 30 volts, then the grid swings 30 volts each side of the operating point. From this, we obtain $i_{b \max}$ and $I_{b \min}$:

$$i_{b \max} = .105 \text{ ampere}$$

$$i_{b \min} = .005 \text{ ampere}$$

Substituting in Equation 30:

$$\begin{aligned} P_o &= \frac{(.105 - .005)^2 \times 1500}{8} \\ &= 1.88 \text{ watt} \end{aligned}$$

An identical procedure may be employed for determining the power output of pentodes and beam-power tubes for given element voltages and signal-input conditions. The plate efficiency of the tube just used in the power calculation may be found by substituting in Equation 29. For example, we may write:

$$\begin{aligned} \text{eff} &= \frac{P_o}{E_b I_h} \\ \text{or} \quad \text{eff} &= \frac{1.88}{250 \times .045} \\ &= .17 = 17\% \text{ approx} \end{aligned}$$

Although the maximum theoretical efficiency of a class-A amplifier may be shown to be 50%, the efficiency of any operating system will actually be much more than this. When an attempt is made to approach 50% efficiency, the distortion becomes very severe. In practice, the maximum efficiency that can be expected from a class-A amplifier is about 25%, with substantially lower efficiencies occurring for average operating conditions.

Before discussing low-frequency class-B push-pull amplifiers, we should mention that certain hybrid classes of operation are often encountered in practical amplifiers. It is necessary, therefore, to differentiate between the broader classifications such as class-A, class-B, and class-C and the finer distinctions between similar classes as symbolized by class AB, and the subscripts 1 and 2 added to the class letter.

Class AB — This class of operation is intermediate between class A and class B. Plate current flows for more than half a cycle but less than a full cycle. Grid current may or may not flow, depending upon the adjustment and drive. This class is particularly suited for high-power audio applications in which moderate efficiency is required but where distortion as great as that of class B cannot be tolerated.

A class-AB audio amplifier must be *push-pull* for the same reasons that apply to class B.

Subscript 1 (e.g. class A_1) – The subscript 1 indicates that the grid of the amplifier is never driven positive, so grid current does not flow during any part of the input cycle. Although the subscript 1 may be used with any class of amplifier, it is most often associated with classes A and AB.

Subscript 2 (e.g. class AB_2) – This subscript denotes that the grid may be driven positive and that the grid current does flow for a small portion of the input cycle. It, too, may be associated with any amplifier class.

23. Review Questions

1. List and describe the ways in which power-amplifier tubes differ from voltage-amplifier tubes.
2. Define power sensitivity.
3. How does the power sensitivity of a pentode compare with that of a triode power amplifier?
4. What is meant by plate efficiency?
5. Distinguish between the three main amplifier classes on the basis of comparative grid bias.
6. Repeat this comparison between amplifier classes, this time on the basis of duration of plate current pulses-per-input-cycle.
7. How do the plate efficiencies of the three main amplifier classes compare with each other?
8. Distinguish carefully between class A_1 and A_2 .
9. Repeat for class AB and class B amplifiers.
10. Why cannot a class B or class C amplifier be used for audio amplification in single-ended form?

Chapter 5

PUSH-PULL POWER AMPLIFIERS

24. The Push-Pull Circuit

When large sound output is desired with a minimum of distortion, as in high-fidelity amplifiers or receivers, two power tubes may be connected in the push-pull circuit shown in Fig. 25. Some important facts relative to push-pull operation are outlined below.

(a) Any amplifier class may be set up in a push-pull circuit. This applies to class C (which is never used in audio work) as well as classes B, AB, and A.

(b) Even-harmonic distortion is minimized by the action of a push-pull circuit. This effect will be discussed separately later.

(c) The power output of a push-pull stage is roughly twice that of the same stage in a single-ended connection.

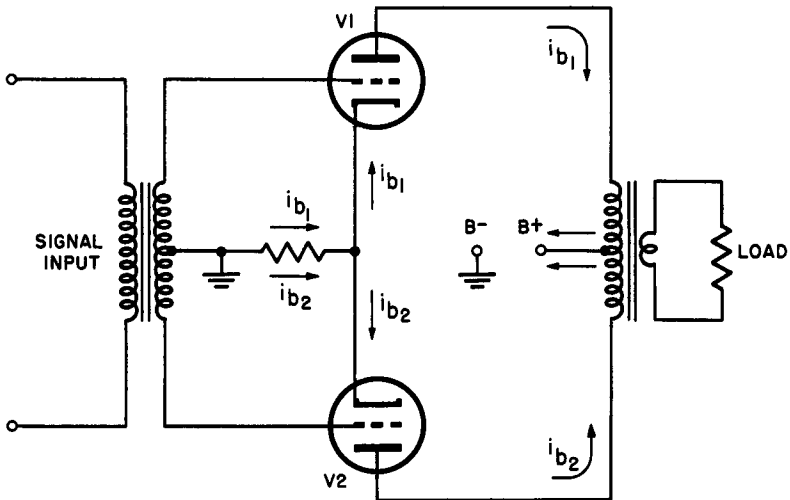

Fig. 25. A push-pull amplifier using triodes.

(d) Greater signal-input voltage can be used without exceeding tolerable distortion level than with a single-ended stage. The reduction of even-order harmonics is responsible for this feature.

(e) The direct current that flows through the primary winding of the output transformer belonging to a single-ended stage is often the cause of distortion resulting from core saturation. The direct currents that flow in the transformer primary of a well-balanced push-pull system are equal in magnitude but opposite in direction. The "standing" magnetic field is thereby cancelled and the danger of core saturation obviated. The reader should trace the zero-signal current flowing in the primary winding of the output transformer in Fig. 25 to verify this for himself.

(f) Hum voltages that appear in the power-output system due to heater-cathode leakages or other similar causes tend to cancel out just as the direct currents do. Thus, less filtering of the power supply is often possible when such power supplies feed only push-pull stages.

(g) When cathode bias is used, a bypass capacitor across the bias resistor may not be necessary, depending on specific operating conditions. The reason for this will become evident when we discuss the fundamental theory of the push-pull circuit.

The operation of a push-pull system depends upon the applications of grid input voltages of 180° phase difference to each of the two tubes. A transformer automatically accomplishes this phase inversion from a single signal source since one end of any secondary winding always reaches a positive maximum referred to the center-tap at the same instant that the other end reaches a negative maximum. (See Fig. 26.)

Assume that the bias produced by the cathode resistor makes the grid of each tube negative by 35 volts with respect to the common cathode connection. If the instantaneous voltage across the entire secondary is 20 volts, the negative grid voltage of one tube is increased by 10 volts (to 45 volts) and that of the other decreased by 10 volts (to 25 volts). Thus, the instantaneous plate current in one tube, say V1, increases while that of the V2 decreases. Since i_{b1} increases while i_{b2} diminishes, these variations produce magnetic effects in the primary of the output transformer *which tend to reinforce each other*. The arrows in Fig. 25 show the directions of the actual plate currents; those in Fig. 27 should be pictured as vectors that illustrate the direction of the *change* of instantaneous plate current.

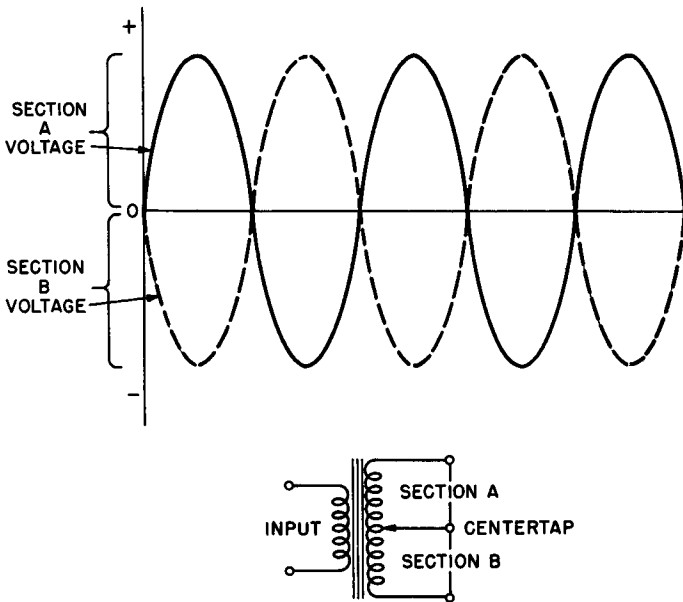

Fig. 26. Curves showing that voltages across each half of a centertapped secondary are 180° out of phase.

That is, it is assumed that the plate current of V1 is increasing, hence its vector is drawn in the same direction as the electron flow; the plate current of V2, on the other hand, is decreasing so that its plate current vectors are drawn opposite to the direction of electron flow.

From Fig. 27 we can find that:

(a) The change vectors are in the same direction in the primary winding of the output transformer, hence, its magnetic field grows and decays just as though a single alternating current were flowing through the entire winding. (As it is, two separate currents flow through each half.) The net effect of this is to induce in the secondary a composite signal consisting of the two components in the primary.

(b) As one tube draws increasing current through the cathode resistor, the cathode current of the other tube decreases to the same degree. The sum of the instantaneous currents flowing through the resistor, therefore, remains essentially constant even though a varying signal is applied to the tube grids. Unlike a single-ended stage, the cathode resistor of a push-pull output circuit does not have to be bypassed; since the net voltage drop across it remains constant,

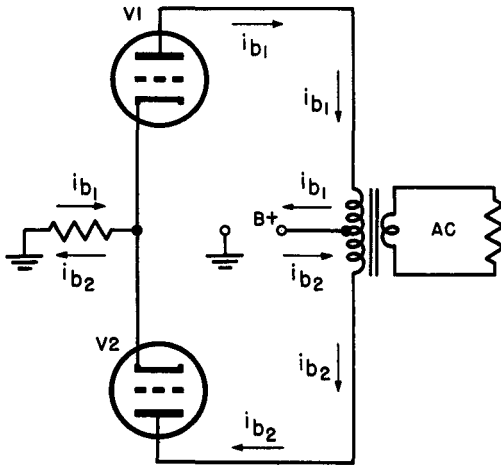

Fig. 27. The push-pull amplifier circuit showing direction change vectors.

there is no a-c component so that there can be no degeneration. All this assumes, of course, that both tubes are identical in all characteristics. Although this is never absolutely true in practice, the differences are generally so small that the action described above may be accepted as quite accurate.

25. Cancellation of Even Harmonics

We have seen that the effect of the “pushing” and “pulling” action of two tubes working together is the production of a resultant field in the output transformer that can induce a corresponding voltage in the secondary winding to drive a load. The push-pull process is an additive one in which an *increasing* current in one-half of the primary of the output transformer combines with a *decreasing* current in the other half to provide a resulting output waveform that is a close replica of the input signal. It is quite logical to conclude that there must be a converse for this rule. That is, if the plate currents through both tubes should increase and decrease *together* — a situation where the output currents of the tubes are in phase instead of being 180° out of phase as they are in push-pull — then such currents would be *subtractive*. With relation to the resultant magnetic field they produce in the output transformer, in-phase currents would completely cancel each other if their amplitudes were equal.

Second harmonic distortion (and higher-order even harmonics) are usually due to the curvature of the tube characteristic. Distortion

tion of this type is virtually unavoidable even when the tube is operated with correct bias and a sufficiently small input to prevent overloading. The waveform typical of second harmonic distortion together with its cause is clearly shown in Fig. 28. The negative peak

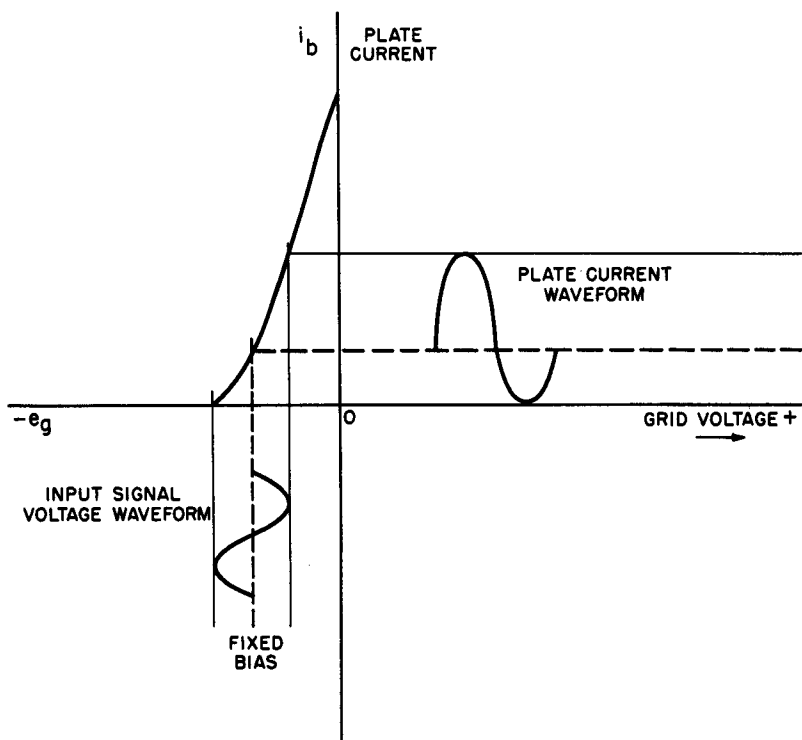

Fig. 28. Second harmonic distortion caused by the curvature of the dynamic phase characteristic.

of the output waveform in this case is flattened. An analogous situation is found when the tube operates near the upper bend of its characteristic; in this event, the positive peak is rounded off. Either of these waveforms indicates the presence of a second harmonic distortion since a sinusoidal fundamental added to a sinusoidal second harmonic results in just this type of wave (Fig. 29).

In a push-pull audio system, the plate current of one tube will vary according to the distorted waveform shown at A in Fig. 30 while the plate current of the second tube will vary as in B. Note that the fundamentals are 180° out of phase while the second har-

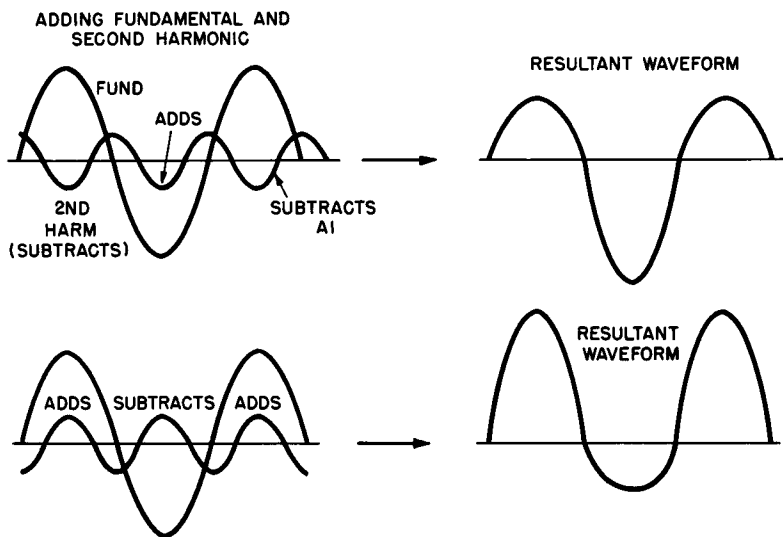

Fig. 29. Resultant waveforms obtained by adding the fundamental and the second harmonic.

monics are *in phase*. If the output waveform amplitudes are equal, then, as explained in the prior paragraph, the out-of-phase fundamentals will be additive and the in-phase harmonics will be subtractive, thereby causing *cancellation* of the cause of the distortion. Thus, the resultant output waveform is a pure sinusoidal which duplicates the input.

26. Class-B Audio Systems

The bias of a class-B amplifier is adjusted so that the plate current is close to zero in the absence of an input signal. As we have seen, such amplifiers are capable of relatively high efficiency from small tubes with medium plate voltages, but cannot be used for audio amplification in single-ended form due to the excessive distortion that would result.

Two tubes in push-pull must be used, the connection being identical with those of Fig. 25. The cathode resistor used to obtain grid bias is often completely omitted, with the cathodes returned directly to ground. The tubes employed in such cases are built with a very high μ , especially for class-B service. In such tubes, the plate

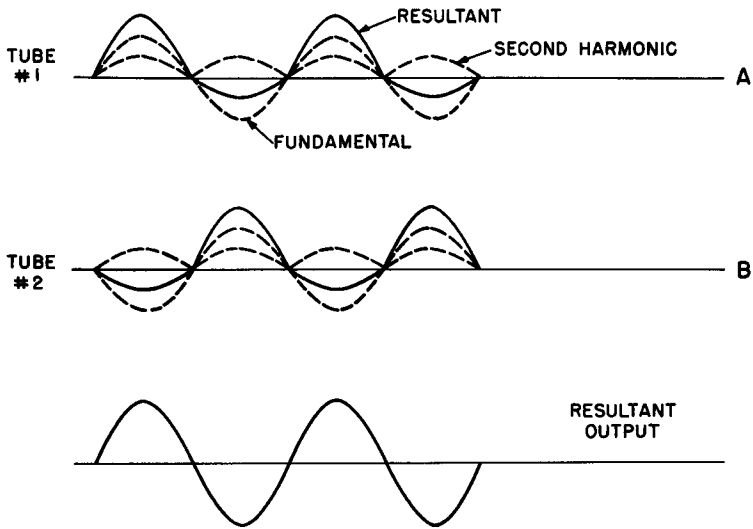

Fig. 30. In push-pull operation, the effects of second harmonic distortion are cancelled.

current is quite small even with zero bias due to the very close spacing used between grid turns. While a class-A amplifier system in push-pull draws plate current at all times, one tube taking more current as the other takes less, class-B tubes take current only while the input signal is driving the grid in a positive direction — away from the cutoff condition (Fig. 20). In push-pull, as a result of the out-of-phase grid drive, one tube of a class-B system takes current while the other takes none at all. When correctly balanced, as soon as one tube drops to cutoff, the other starts to pass plate current. In effect, each half of the output cycle is supplied by one of the class-B push-pull tubes so that the overall output is a full cycle which is a replica of the input waveform (Fig. 31). Because the input and output of each class-B tube is out of phase by 180° with the other, the axes of tube B in Fig. 31 have been rotated through 180° in order to obtain the composite waveform in its true appearance. The small break along the horizontal axis between the two output half-cycles is small enough in practice to have only a negligible effect on the sound.

Class-B systems differ substantially from class-A in several respects:

- (a) Each tube passes current for alternate half cycles and con-

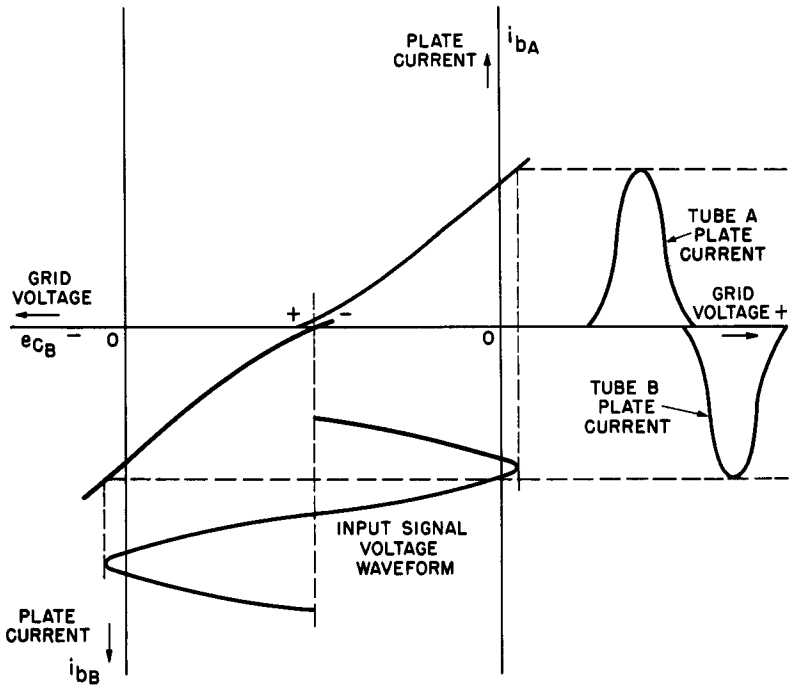

Fig. 31. Curves showing the addition of two halves of a class-B system to duplicate the input waveform.

sequently only half the primary of the output transformer is carrying current when a signal is applied. Thus, the cancellation of the d-c magnetization effect found in class-A arrangements does not take place in class-B. Hence, signal current is present in the common B+ to-cathode lead. Class-B output transformers therefore require a larger core to avoid saturation by the d-c plate current and are often seven times as heavy.

(b) The rapid changes in d-c requirements in class-B amplifiers call for a power supply of excellent voltage regulation. The current-change ratio often exceeds 10:1 in short intervals. The resistance of filter chokes must be very small, and the power transformer and rectifier must be capable of meeting the varying current demand.

(c) Fixed bias must be used due to the rapidly changing cathode current.

(d) The grids of efficiently operated class-B output stages are

almost always driven positive by the input signal and hence draw current. The driver stage in this case must be capable of supplying the power requirements of the class-B grid circuit and the bias supply must have good voltage regulation. The exception to the driver-power requirements is encountered when pentodes are operated in class-B₁ (no grid current).

27. Review Questions

1. Aside from the reduction of even-harmonic distortion, what are the advantages of a push-pull output stage?
2. Explain why the output transformer of a class-A push-pull amplifier may be smaller than that of a single-ended class-A amplifier rated for the same output.
3. Why are the cathode resistors of push-pull class-A stages often left unby-passed?
4. Can a class-B push-pull amplifier be cathode-biased? Why?
5. Explain briefly why push-pull operation results in the cancellation of second harmonic distortion.

Chapter 6

PRINCIPLES OF TRANSISTOR AMPLIFIERS

28. Introduction

Although the functions of amplification and oscillation are common to vacuum tubes and transistors, their structures and operating principles are so completely different that analogies drawn between them are often highly artificial and unsatisfactory. The part that a transistor plays in an amplifier or oscillator circuit should be approached as a new concept rather than a modification of an old one involving vacuum tubes. Although it is assumed that the reader is familiar with the fundamental theory of transistor operation, some important ideas and concepts relevant to amplification are summarized below.

Configurations — Transistors may be connected in amplifier circuits in three different configurations: common-base (or grounded-base), common-emitter, and common-collector. Since there are two different types of transistors — p-n-p and n-p-n — in the “triode” category, the power sources, usually batteries, must be carefully connected in the correct polarity. Figure 32 shows the three configurations for both p-n-p and n-p-n transistors. E_b is the potential which provides the necessary forward bias for the emitter circuit and E_c is the collector voltage source. The collector voltage is always polarized so that the bias it produces is *reverse* bias. In all transistor configurations, regardless of type, the emitter is always biased in the forward or *low-impedance* direction and the collector in the reverse or *high-impedance* direction.

Characteristics of the configurations — When an amplifier is to be designed or applied in practical equipment, the principal concerns of the worker, particularly in connection with low-frequency equipment, are input impedance, output impedance, voltage gain, and power gain. With the wide variety of transistors on the current market, it is obviously impossible to provide actual values for these

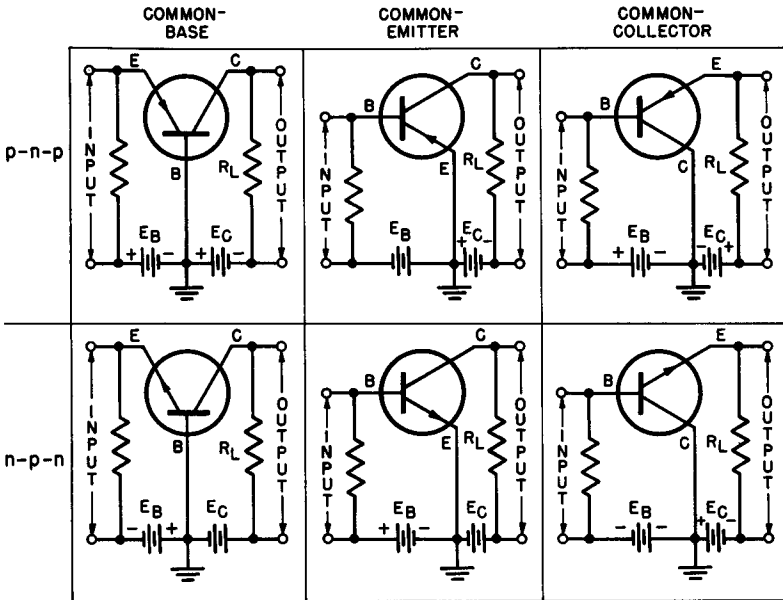

Fig. 32. Basic configuration for n-p-n and p-n-p transistor-amplifier circuits.

characteristics in quantitative terms. It is valuable, however, to study the *order of magnitude* of these factors on a comparative basis. The reader should recognize that the figures are given merely as guides for qualitative comparison of configurations.

The common-emitter arrangement has a somewhat lower output impedance than the common-base circuit, yet it is enjoying much greater popularity, mostly because of its capabilities for higher voltage and power gains. The common-base configuration is often used where an extremely low input impedance is required to match the impedance of some input device, such as a carbon microphone in a transistor modulator, whose output impedance is correspondingly low. It should also be recognized that the output impedance of the common-base transistor amplifier is substantially higher than that of the other configurations; thus, a common-base circuit is more suitable for feeding an oscilloscope or similar instrument having very high input impedance characteristics.

The common-collector amplifier is used principally as an impedance transformer since its voltage gain is always less than unity and its power gain appreciably lower than the other configurations.

Like the cathode-follower vacuum-tube amplifier, the common-collector amplifier is often used to eliminate matching transformers going from a high impedance to a low impedance where such transformers would be undesirable due to cost, bulk, weight, or frequency characteristics; for this reason the common-collector amplifier is also called an "emitter follower."

29. Alpha and Beta

Unlike vacuum tubes, transistors are current-operated rather than voltage-operated. It is customary to describe the behavior of a given transistor in a specific configuration on the basis of its current gain.

Current gain applied to the common-base arrangement is defined:

$$\text{current gain (common-base)} = \alpha = \frac{\Delta I_c}{\Delta I_e}$$

It is evident from this definition that the change of output current in the collector circuit (I_c) is being compared with the causative change of input current in the emitter circuit (I_e). In the basic explanations of common-base action, it is clear that the base current (I_b , Fig. 33) is the result of a small number of recombinations of

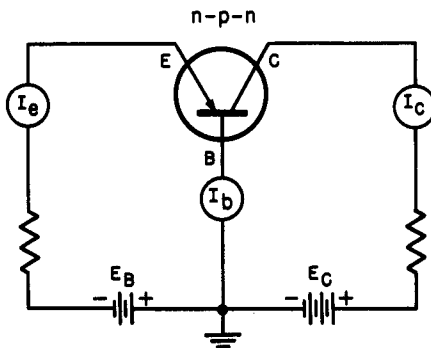

Fig. 33. Basic common-base transistor amplifier circuit.

holes and electrons and that, due to the thin cross-section of the base material, most of the current carriers from the emitter proceed through the collector circuit to produce the collector current I_c . Thus, the base current is the arithmetic difference between the emitter and collector currents and is invariably much smaller than either

of the others. The base current always reduces the current flowing from emitter to collector, and even though this diminution is small, the collector current can never be quite as large as the emitter current in the common-base arrangement. This means, of course, that the ratio that defines alpha can never reach unity. Thus, the current gain of a common-base transistor amplifier is always less than one.

TABLE III
COMPARISON OF TRANSISTOR CHARACTERISTICS

<i>Characteristics</i>	<i>Common Base</i>	<i>Common Emitter</i>	<i>Common Collector</i>
Input impedance	50 ohms	500 ohms	10,000 ohms
Output impedance	500,000 ohms	50,000 ohms	100 ohms
Voltage gain into proper load	100	300	0.95
Power gain	25	40	20

The voltage gain, however, can be much greater than unity, as indicated in the table of characteristics given previously. Voltage gain is the result of the different input and output impedances that may be used in this transistor configuration. Although the current gain may be in the order of 0.9, the *resistance gain* (*i.e.* ratio of input to output impedance) is very much higher. Based upon the figures in Table III, this ratio may reach 10,000 (500,000 ohms to 50 ohms) giving a resistance gain of the same value. Voltage gain may be obtained from Equation 31:

$$\text{Voltage gain} = \text{current gain} \times \text{resistance gain} \quad (31)$$

and using the figures above, a voltage gain of $0.9 \times 10,000 = 9000$ is theoretically possible. In practical circuits, gains of this magnitude are never realized because external input and output impedances required for proper transistor operation reduce the gain ratio to much smaller figures.

The *beta* (β) of a transistor applies particularly to the common-emitter configuration. Since the input signal is applied to the base rather than the emitter in this circuit, the base current must vary. To determine the current gain in this case, therefore, we are concerned with the ratio of the change of collector current to the change

of causative base current. Thus, the current gain in the common-emitter transistor amplifier is defined:

$$\text{common-emitter current gain} = \beta = \frac{\Delta I_c}{\Delta I_b}$$

Beta for junction transistors is almost invariably greater than unity, in contrast to common-base current gain, alpha, for the same units. This might have been anticipated since the base current, to begin with very small, if changed might be expected to result in larger variations in the collector current.

30. Establishment of Operating Point

The characteristic curves of Fig. 34 are those of a typical junction transistor* in which the collector current is shown as a function of the collector voltage for various values of base current. The following absolute maximum values are given in the ratings of this transistor:

Maximum collector voltage = 15 volts

Maximum collector current = 20 ma

Maximum collector power dissipation = 50 milliwatts.

To establish a satisfactory operating point, it is customary to first fix the value of the supply voltage (E_{bb}), select the desired idling collector current (I_c) and collector voltage (E_c), and then determine the value of load resistance required to yield this current and voltage. The collector voltage E_c is given by the equation:

$$E_c = E_{bb} - I_c R_L \quad (32)$$

Examination of the curves discloses that an operating point which will provide a wide swing of possible base currents (these correspond, of course, to the input currents in the common-emitter connection) would be at a point where the collector current is 3.5 ma and the collector voltage is, conveniently, 6 volts. This point is marked O.P. on the 125-microampere (μA) curve of Fig. 34. Since the absolute maximum collector voltage is 15 volts; let us select a supply voltage of 12 volts in order to remain well within the maximum ratings. A load line may now be drawn connecting the supply

* General Electric 2N78.

Fig. 34. Collector characteristics of a typical junction transistor with common emitter configuration.

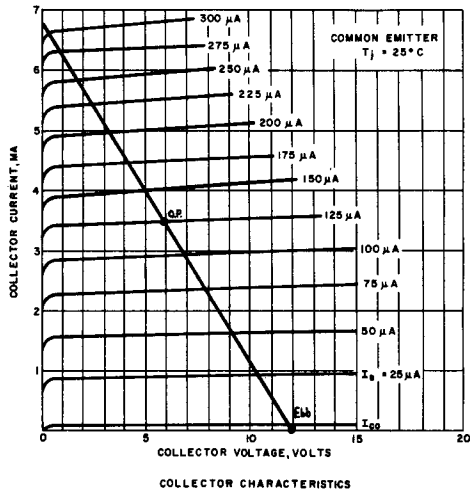

voltage ($E_{bb} = 12$ volts) with the operating point and extended until it intersects the collector current axis to ascertain whether this selection of values will permit a collector current greater than the maximum rating to flow with E_c equal to zero. The load line intersects the vertical axis at a point between 6 and 7 ma. Since the maximum collector current rating is 20 ma, this value is entirely satisfactory.

To determine the load resistance required for this load line it is necessary to solve Equation 32 for R_L . Thus

$$E_c - E_{bb} = -I_c R_L$$

changing signs

$$E_{bb} - E_c = I_c R_L$$

and

$$R_L = \frac{E_{bb} - E_c}{I_c} \tag{32a}$$

The values previously determined may now be substituted in Equation (32a). That is, $E_{bb} = 12$ volts, $E_c = 6$ volts, $I_c = 3.5$ ma.

$$\begin{aligned} R_L &= \frac{12 - 6}{.0035} \\ &= 1700 \text{ ohms (reduced to two significant figures)} \end{aligned}$$

As the base current is swung by the input signal between, say, 50 and 225 μa , the collector voltage will vary from 9 down to 2.5 volts and the collector current will range between 1.6 and 5.4 ma. Signal swings larger than these are possible, of course, since the permissible base current goes as high as 300 μa and down as low as zero.

In some applications, both the supply voltage and the load resistance are fixed. In such cases, it is necessary to select the operating point on the basis of these circuit values. Assuming the load resistance to have a predetermined value of 1700 ohms and the supply voltage to be 12 volts, the operating point may then be chosen at any point, within reason, along the load line by establishing the correct value of d-c base current. For example, if the bias fixes the base current at 100 μa under these conditions, then the operating point will be at the intersection of the 100- μa I_b curve and the load line. Thus, the d-c operating point will be one in which the collector voltage is approximately 6.8 volts and the collector current approximately 2.9 milliamperes. Evidently, the original operating point (o.p. in Fig. 34) may be restored by changing the bias so that 125 μa of base current flows, if this condition is more desirable than the other.

31. Biasing Methods

Fixed bias — From the development presented in the preceding paragraph, we see that the base bias determines the collector voltage for any given load resistance and supply potential. A standard method of applying base bias from a single-battery source consists of connecting a suitable resistor from the proper battery terminal to the base electrode. The circuits for both n-p-n and p-n-p transistors are shown in Fig. 35. Since only the base current flows through this resistor, the value required to establish the desired base current may be calculated from the simple equation:

$$R_T = \frac{E_{bb}}{I_b} \quad (33)$$

where R_T is the total series resistance consisting of the external base resistor R_b and the internal resistance of the base circuit. Since the latter is very small in the common-emitter configuration (in the order of 500 ohms), it may be ignored in the calculations since it

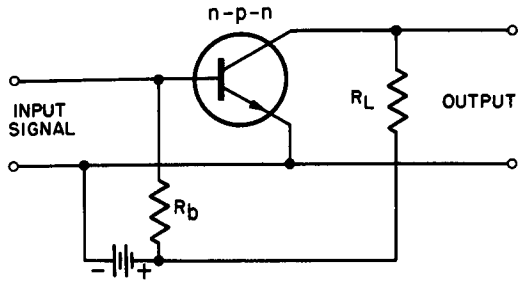
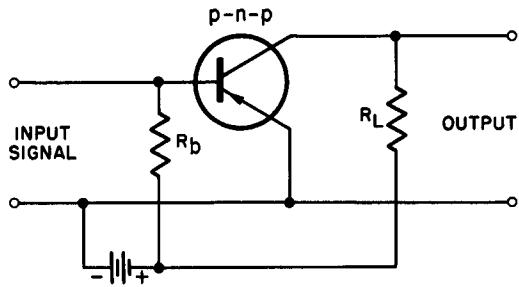

Fig. 35. Connection of base-bias resistor for n-p-n and p-n-p transistors.



will not influence the choice of R_b to a significant degree. Hence Equation 33 simplifies to:

$$R_b = \frac{E_{bb}}{I_b} \tag{34}$$

To illustrate the use of Equation 34, consider the operating point and circuit values established in the previous illustration. Assuming that the supply voltage is 12 volts ($E_{bb} = 12$ volts) and the base current wanted is 125 μ a, then the base resistor is:

$$\begin{aligned} R_b &= \frac{12}{1.25 \times 10^{-4}} \\ &= 96,000 \text{ ohms} \end{aligned}$$

This resistance is correct for both the n-p-n or p-n-p transistor. The only difference between the finished circuits is the reversal of battery polarity.

Degenerative bias — Regardless of the care exercised by the transistor manufacturer, variations exist between units of similar type number. Also, the fact that transistors tend to alter character-

istics slightly as a result of changing temperatures makes for a shift of the operating point in identical circuits with identical components and bias. For instance, the collector current that flows when the base current is zero (I_{co}) is seldom the same in similar transistors. As a result of the unreliability of I_{co} , it is accepted practice to arrange the biasing circuit in such a way that stabilization is achieved through degeneration.

A simple method of applying degenerative bias is given in Fig. 36. The resistor R_b is connected directly from the collector to the base. The manner in which R_b controls the operating point can be

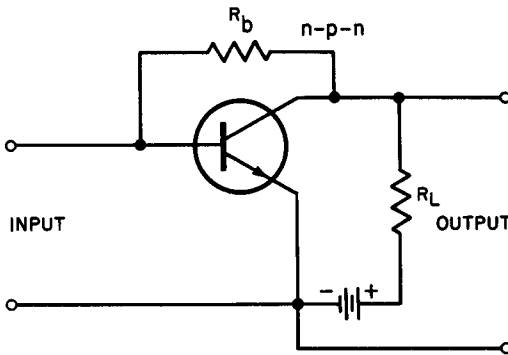

Fig. 36. Degenerative bias is obtained by connecting the base bias resistor directly from collector to base.

seen by referring to the load-line picture in Fig. 34. Assume that the collector current increases due to a rise in ambient temperature (or some other cause); this lowers collector voltage and with it, the base bias, resulting in the flow of reduced base current. An increment in base current tends to reduce collector current so that the voltage drop across R_L reduces, causing the collector voltage to come back up nearer its original value.

Equation 34 cannot be used to determine the size of R_b in this connection since it is the collector voltage rather than the source voltage that governs the base bias and hence the base current. The value of R_b may be obtained from Equation 35.

$$R_b = \frac{E_c}{I_b} \quad (35)$$

Using the figures given in the previous example, if the collector

voltage is to be established at 6 volts with a base current of $125 \mu\text{a}$, then the bias resistor R_b must be:

$$R_b = \frac{6}{1.25 \times 10^{-4}} = 48,000 \text{ ohms}$$

It should be noted that the selection of the base-bias resistor is dictated by the established operating point. Although it contributes to stabilization, this is not its primary function; thus, if the resistor values required for establishing *both* proper bias, and adequate stabilization are too divergent in value, stabilization effectiveness must suffer.

Hunter-Goodrich bias method – In the preceding development it was shown that the base resistor R_b , connected directly to the base electrode from the collector, provides a definite amount of negative feedback which contributes to temperature stability. The magnitude of the negative feedback, however, may be too small for effective control and stabilization in many applications, because R_b may have to be made too large in compliance with the bias requirements as explained. This objection to straightforward degenerative bias may be overcome to a large extent by adding a second resistor and battery as illustrated in Fig. 37. The auxiliary battery E_n is polarized

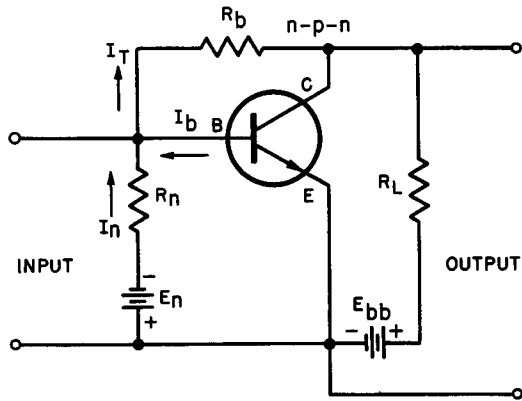

Fig. 37. Bucking (Hunter-Goodrich) method of improving degenerative action.

opposite from the normal bias voltage normally encountered in n-p-n transistors. In order to buck out this additional voltage, R_b must be made considerably smaller in value to allow the base electrode to assume the positive proper magnitude. By making R_b smaller, the effectiveness of the degenerative feedback is enhanced

since collector voltage changes are now transferred with less opposition to the base.

To calculate the required values of R_b and R_n in this circuit, it is necessary to know the auxiliary voltage available (E_n) and the magnitude of the current flowing in R_n (I_n). Assume that a 6-volt battery (E_n) is available. Good design practice indicates that, for good stabilization, the bucking current I_n should be approximately 50% of I_b , or about 60 μa in our example. From this we obtain:

$$R_n = \frac{E_n}{I_n} = \frac{6}{6 \times 10^{-5}} = 100,000 \text{ ohms}$$

The current flowing through R_b is evidently the sum of I_n and I_b or:

$$I_t = I_n + I_b = 60 + 125 = 185 \mu\text{a}$$

Thus:

$$\begin{aligned} R_b &= \frac{E_n}{I_t} = \frac{6}{1.85 \times 10^{-4}} \\ &= 32,000 \text{ ohms approx} \end{aligned}$$

Compare this value of R_b with that obtained for the straightforward degenerative bias case (48,000 ohms). It is clear that the stabilization action of the negative feedback will be improved by this arrangement. The bucking-bias method of stabilization is valuable in circuitry where temperature compensation is important. An obvious disadvantage of the system is that an auxiliary battery is required and that there is an added collector load acting in parallel with R_L through E_{bb} , R_b , R_n and E_n .

Combination bias — A result similar to that described above can be realized by interchanging the positions of R_L and E_{bb} in the collector circuit and omitting E_n entirely. This is shown in Fig. 38.

The feedback resistor E_n is now connected to the negative terminal of the main voltage source, providing a bucking current of 60 μa as before. The action is essentially the same as the circuit previously described except that the reverse bias provided by E_{bb} is no longer fixed since voltage variations due to collector-current changes occur at the top of R_L . Since the base-to-collector resistance within the transistor may be ignored in comparison to the other series resistance present, the voltage applied across R_n is essentially E_c . Thus, the value of R_n may be computed from:

Fig. 38. Combination bias method using negative feedback resistor with single battery.

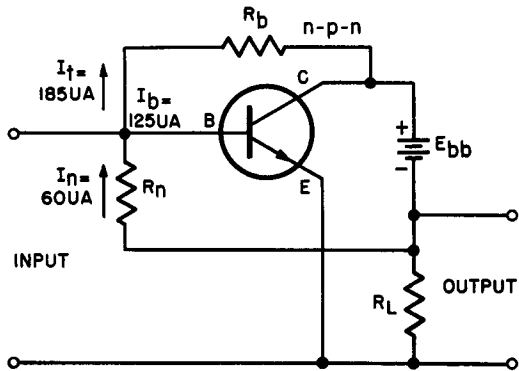

$$R_n = \frac{E_c}{I_n}$$

Assuming that the same bucking current is wanted (i.e. 60 μ a), then:

$$R_n = \frac{6}{6 \times 10^{-5}} = 100,000 \text{ ohms}$$

But in this instance, both currents, I_n and I_t add together to determine *total* stabilizing effect.

32. Review Questions

1. Why is the common-emitter configuration gaining widespread usage in preference to the other configurations?
2. Which of the transistor configurations is most suitable as a high-to-low impedance transformer? Explain.
3. Which transistor configuration would be used as an input amplifier stage to be fed directly from a 50-ohm carbon microphone?
4. Why cannot the common-base arrangement have a current gain greater than unity?
5. A transistor in the common-base arrangement has a current gain of 0.92 and a resistance gain of 7000. What is the theoretical voltage gain?
6. How does beta differ from alpha? Define both terms and give the configurations to which they apply.
7. What advantage does degenerative bias possess over fixed transistor bias?
8. Explain how the Hunter-Goodrich bias method overcomes the deficiencies of the straight degenerative method.
9. What are the disadvantages of the Hunter-Goodrich method?
10. Compare the three transistor configurations with respect to voltage gain and power gain.

INDEX

- A-C component, 3
- Alpha, 68, 69
- Alternating plate current component, 4
- Amplification factor, 8, 10, 32, 34, 46
- Amplifier circuit components and their symbols, 3
- Amplifier classes, 47-51
 - audio, 47
 - class A operation, 47
 - class AB₁ operation, 56
 - class AB₂ operation, 56
 - class B operation, 47, 48, 62-65
 - class C operation, 50
 - d-c, 47
 - radio frequency, 47
 - transformer coupled, 47
 - tuned, 46
 - untuned, 46
- Amplifier components, 2, 3
- Amplifier criteria, 16-20
- Amplifier distortion, 39
- Amplitude distortion, 39

- Bass-boost, 31
- Beampower amplifier, 10, 53
- Bel, 24
- Beta, 68, 69
- Bias:
 - battery, 13
 - bleeder, 12
 - bucking-bias, 76
 - cathode, 11, 59
 - combination, 76
 - control-grid, 7, 10-14
 - degenerative, 73, 75
 - fixed, 64, 72
 - Hunter-Goodrich, 75

- Currents and voltages, grid and plate circuits, 3-7

- D-C amplifier, 1
- D-C component, 3
- D-C plate resistance, 46
- Decibel, 24-26
- Decibel reference level, 26, 27
- Distortion, 16
- Dynamic plate resistance, 8, 32
- Dynamic transfer characteristic, 40

- Even harmonic cancellation, 60, 61
- Even harmonic distortion, 57
- Equalization, 17
- Equivalent circuit, 7-10

- Filter:
 - bandpass, 17
 - band-reject, 17
 - high-pass, 17
 - low-pass, 17
 - network, 17
 - single frequency-reject, 17
- Fletcher-Munson contours, 29, 30, 31
- Frequency response, 16, 17, 23
 - curve, 27, 28, 29
 - distortion, 39, 57
 - flat range, 28
 - fundamental, 43
 - lower treble range, 29
 - nonuniform, 29
- Fundamental triode amplifier, 7

- Grid circuit voltages, 3, 4

- Harmonic distortion, 39, 43
- High fidelity reproduction, 1, 16
- Hum-level, 18
- Hum voltages, 58

- Impedance:
 - input, 19
 - load, 54
 - matching, 18, 20
 - output, 19

- Junction transistor, 70

- Load impedance, 7
- Load lines, 36, 37, 38
- Load resistance, 35, 72
- Logarithmic response, 24
- Loudness control, 31
- Low-frequency amplifiers, 2, 21
- Low-frequency spectrum, 1, 2
- Low-frequency voltage amplifiers, 32-43

- N-P-N transistors, 66

- Pentode amplifier, 10
- Pentode voltage gain, 34, 35, 36
- Phase distortion, 43
- Plate characteristics curve, 36
- Plate circuit voltages and currents, 4
- Plate efficiency, 46, 53-56
- Plate potential, 7
- Plate resistance, 35
- P-N-P transistors, 66
- Power amplifiers:
 - single-ended, 45-56
 - push-pull, 57-77
- Power dissipation, 12
- Power output, 16
 - calculations, 53-56
 - gain, 24
 - loss, 25
 - maximum, 20
 - minimum, 21
- Power sensitivity, 46
- Push-pull circuits, 57-60

- Quiescent:
 - plate current, 5, 8, 38
 - plate voltage, 37
 - voltage amplification, 38

- Review, 14, 15, 31, 43, 44, 56, 65, 77

- Screen grid voltage and current, 6, 7
- Secondary emission, 7
- Self-bias, 11
- Series-filament bias, 13
- Servo-amplifier, 1
- Signal voltage, 4, 8
- Suppressor grid, 7

- Tables:
 - comparison of transistor characteristics, 69
 - grid voltage — plate voltage relationships, 40
 - ratings and characteristics of the 6L6, 53
- Threshold of audibility, 21, 22
- Tone control, 17
- Transconductance, 33, 35
- Transistor amplifiers, 66-77
- Transistor configuration:
 - common base, 66, 67, 68
 - common collector, 66, 67
 - common emitter, 66, 72
- Transistor operating point, 70, 71, 72
- Triode amplifier, 7, 10
- Tube voltages and currents and their symbols, 6

- Ultrasonics, 1

- Vacuum tube amplifier, 2
- Vacuum tube characteristics, 32, 33, 34
- Voltage amplification, 8, 9, 28
- Voltage gain, 10, 16, 35, 69