

**199 *Electronic Test &  
Alignment Techniques***

No. 593  
\$7.95

# 199 Electronic Test & Alignment Techniques

By Art Margolis



**TAB BOOKS**

Blue Ridge Summit, Pa. 17214

FIRST EDITION

FIRST PRINTING—FEBRUARY 1972

Copyright ©1972 by TAB BOOKS

Printed in the United States  
of America

Reproduction or publication of the content in any manner, without express permission of the publisher, is prohibited. No liability is assumed with respect to the use of the information herein.

International Standard Book No. 0-8306-2593-3

Library of Congress Card Number : 74-188706

# Contents

<b>PREFACE</b>	<b>7</b>
<b>1 "TOOLS" FOR TESTING</b>	<b>9</b>
Multitesters—Oscilloscopes—Signal Generators—Power Meters—Field Strength Meters—Tube Testers—Transistor Testers—Decade Boxes	
<b>2 AM RADIO</b>	<b>26</b>
No. 1: Peak IF Alignment-VTVM—No. 2: Peak IF Alignment-Scope—No. 3: Broadband Alignment-Scope—No. 4: Front-End Alignment-Scope—No. 5: Ferrite Core Antenna Alignment—No. 6: Tracking-Small Transistor Radio—No. 7: Grid-Dip Meter Antenna Test-Small Transistor Radio—No. 8: Local Oscillator Test-Transistor Radio—No. 9: Local Oscillator Test-Tube Radio—No. 10: IF Oscillation Test-Transistor Radio—No. 11: AGC Test	
<b>3 FM RADIO</b>	<b>46</b>
No. 12: Discriminator Alignment-FM Radio—No. 13: IF-Limiter Alignment—No. 14: RF-Oscillator Alignment—FM Converters—No. 15: FM Converter Oscillator Alignment—No. 16: Aligning the FM Converter RF Input—No. 17: Aligning the FM Converter IF Output—No. 18: Routine Testing of the FM Converters—No. 19: Checking Stereo Separation-Multiplex—No. 20: Checking Circuit Phase—No. 21: Multiplex Circuit Alignment—No. 22: Multiplex Circuit "Lock-In" Ability—No. 23: Multiplex Circuit Check	
<b>4 POWER MONITOR TESTS</b>	<b>65</b>
No. 24: Line Current Power Monitor Tests—No. 25: AC Line Power—No. 26: AC Line Voltage Monitoring—No. 27: Fuse Design Test	
<b>5 TV TESTS</b>	<b>69</b>
No. 28: IF AGC TV Tests—No. 29: RF AGC Test—No. 30: Horizontal Output Current—No. 31: Color TV Gray-Scale Test—No. 32: Color TV Purity—No. 33: Color TV Dot Convergence—No. 34: Color TV Crosshatch Con-	



vergence—No. 35: Color TV AFPC Alignment—No. 36: Vectorscope Hookup—No. 37: Stagger-Tuned IF Alignment—No. 38: DC Hi-Voltage Test—No. 39: RF-IF Scope Signal Tracing—No. 40: Video Sweep Modulation Test—No. 41: High-Impedance Probe Test—No. 42: Video Exploratory Test—No. 43: Sync Exploratory Test—No. 44: Color Exploratory Test

## **6 ANTENNA SYSTEMS 100**

No. 45: Calculating the Decibel-Antenna Systems—No. 46: TV Microwatts—No. 47: Field Strength Test—No. 48: Field Intensity to Signal Strength Relationship—No. 49: Checking Signal Generator Output—No. 50: Standing Wave Ratio; SWR Impedance Test—No. 51: UHF, VHF, & FM Antennas on Same Mast—No. 52: TV Master Amplifiers Output Tests—No. 53: Impedance Matching & Conversion—No. 54: UHF Considerations—No. 55 TVI Location Pinpointing

## **7 SEMICONDUCTOR TESTS 116**

No. 56: Handling Damage Test—No. 57: Checking Unknown Transistor—No. 58: DC Beta—No. 59: AC Beta—No. 60: AC Beta Test Setup—No. 61: Open Transistor Test—No. 62: E to C Dead Short Test—No. 63: E to C High-Resistance Short Test for Beta—No. 64: E to C Low-Resistance Short Test for Beta—No. 65: B to C Short Test for Beta—No. 66: B to E Short Test for Beta—No. 67: Make-Sure Test—No. 68: Transistor Leakage Test—No. 69: Switched Leads, Collector and Emitter—No. 70: Switched Leads, Collector and Base—No. 71: Switched Leads, Emitter and Base

## **8 TESTING FETs 127**

No. 72: Testing FETs for Gm (Hookup)—No. 73: IGFET Testing 2nd Gate for Gm (Hookup)—No. 74: JFET Testing 2nd Gate for Gm (Hookup)—No. 75: Depletion Mode Bias Test (Hookup)—No. 76: Enhancement Mode Bias Test (Hookup)—No. 77: FET Test for Gm—No. 78: Short Test, Source to Drain—No. 79: Short Test, Gate to Drain—No. 80: Short Test, Gate to Source—No. 81: Open Test, Gate Depletion Type—No. 82: Open Test, Gate Enhancement Type—No. 83: Open Test, Source—No. 84: Open Test, Drain—No. 85: JFET Bias Pos Instead of Norm—No. 86: IGFET Bias Pos Instead of Norm—No. 87: MOSFET Bias Norm Instead of Pos—No. 88: Source and Drain Leads Switched—No. 89: Gate Drain Leads Switched JFET N-Channel—No. 90: Gate and Source Leads Switched JFET N-Channel—No. 91: Gate and Drain Leads Switched, IGFET N-Channel Depletion Type—No. 92: Gate and Source Leads Switched, IGFET N-Channel

Depletion Type—No. 93: Gate Leadage, JFET—No. 94: Gate Leakage, IGFET—No. 95: Gate Leakage (IGSS)—No. 96: Gate Leakage (IG2SS)—No. 97: Testing Dual FETs—No. 98: Matching Test for Bipolars—No. 99: Matching Test for FETs—No. 100: IDSS Depletion FET Test—No. 101: IDSS Enhancement FET Test—No. 102: FET Dissipation Test—No. 103: Human Body Grounding—No. 104: Maintaining Shorted Leads—No. 105: Soldering Precautions—No. 106: FET Oscillation Test—No. 107: FET Oscillation Limit Test—No. 108: Transistor-FET Freeze Test—No. 109: Transistor Potentiometer Test—No. 110: Lo-Power Ohms Function Test—No. 111: An Even Lower Power Ohms Test—No. 112: Small Thermistor Test—No. 113: Figuring Diode Polarity—No. 114: Testing Diode In-Circuit—No. 115: Testing Diode Out of Circuit—No. 116: Grading the Diode—No. 117: Varicap Diode Test—No. 118: Zener Diode Knee Voltage—No. 119: Component Substitution Tests—No. 120: Subtracting Resistance Test—No. 121: Adding Capacitance Test—No. 122: Adding Resistance Test—No. 123: Subtracting Capacitance Test—No. 124: In-Circuit Transistor Audio Waveform Test—No. 125: In-Circuit Transistor Audio Frequency Response Test—No. 126: Power Transformer Outputs

## **9 POWER SUPPLIES** **158**

No. 127: Checking Ripple in Power Supply—No. 128: Accurate Voltage Tests—No. 129: Zero Center Range Test

## **10 REMOTE CONTROL SYSTEMS** **162**

No. 130: Transmitter or Receiver, FR Type—No. 131: Transmitter or Receiver, Audio Type—No. 132: Transmitter Substitute Test—No. 133: Transmitter Battery Test—No. 134: Transmitter Output Test—No. 135: Transducer Test—No. 136: Transmitter Defect Test—No. 137: Transmitter Alignment—No. 138: Simple Alignment, Remote Receiver—No. 139: A Motor Won't Start—No. 140: Motor Starts But Won't Run Unless Button is Held Down—No. 141: Motor Runs Past Desired Stops—No. 142: Motor Stops Prematurely—No. 143: Motor Won't go Both Ways—No. 144: Neither Up or Down Works—No. 145: Motor Won't Go Both Ways (Alternate)—No. 146: Stepper Relay Won't Work—No. 147: Dead Remote Receiver

## **11 ELECTRONIC ORGANS** **178**

No. 148: Organ Tune Up—No. 149: When One Note Doesn't Work—No. 150: Testing a Circuit Without Service Notes—No. 151: Signal Tracing Organ Circuits—No. 152: Testing the Oscillator Frequency—No. 153: Testing Divider Circuits—No. 154: Block Diagram Signal Tracing—No.

155: Signal Injection Tests—No. 156: Finding Source of Oscillation—No. 157: Incorrect Musical Note-Not Enough Bias on Divider Circuits—No. 158: Incorrect Musical Notes-Too Much Bias on Divider Circuits

## **12 ELECTRONIC VOCAL CHORDS 187**

No. 159: Power Supply Test DC—No. 160: Signal Injecting a Dead EVC—No. 161: Spurious Pulse Elimination—No. 162: Signal Tracing the Dead EVC—No. 163: Pitch Control Test—No. 164: Pulse Width Test—No. 165: Permissible Current Drain Test

## **13 INTERCOM SYSTEMS 192**

No. 166: Acoustic Feedback Test—No. 167: Signal Injection Tests-Speakers—No. 168: Signal Injection Tests-Amplifier—No. 169: Signal Tracing Tests—No. 170: Output Oscillation Test-Tube—No. 171: Cable Power Loss Test-Percentage—No. 172: Cable Power Loss Test—No. 173: Speaker Impedance Considerations

## **14 GARAGE DOOR OPENERS 201**

No. 174: House Current Checkout—No. 175: Motor and Mechanical Checkout—No. 176: Motor Short Test—No. 177: Motor Open-Circuit Test—No. 178: Motor Runs in One Direction—No. 179: Elimination of Good Remaining Units—No. 180: Receiver or Transmitter?—No. 181: Transmitter Test—No. 182: Receiver Test—No. 183: Shortened Range Test—No. 184: Relay Not Contacting Test—No. 185: Relay Chatter Test—No. 186: Unwanted Operation Adjustment—No. 187: Unwanted Operation Due to Noise—No. 188: Unwanted Operation, Alignment

## **15 AUTO IGNITION SYSTEMS 211**

No. 189: Ignition System Primary Waveform—No. 190: Ignition System Secondary Waveform—No. 191: Paraded Waveform—No. 192: Paraded Compression Check—No. 193: Number One Cylinder Compression Check—No. 194: Marking the Paraded Waveform—No. 195: Timing Light Checks—No. 196: RPM Measurements—No. 197: Voltage Readings for Open Circuit—No. 198: Voltage Readings for Short Circuit-Points Open—No. 199: Voltage Reading High-Points Closed

## **INDEX 223**

# Preface

When a resistor opens and is visually defective—broken in half—when a capacitor is dead shorted and reads zero ohms, when a transformer starts burning, the test is almost automatic and the conclusion is definite. There are no ifs, ands or buts; the eye, ohmmeter and sense of smell tell you what part is unsatisfactory. However, when your garage door opener goes up but won't come down, when your neighbor without a larynx has his electronic vocal chord stop producing his voice, when your car starts to miss and your intercom begins whistling, the test is not exactly automatic and you have no immediate idea of which part is unsatisfactory.

During such an electronic crisis, you have to perform tests to determine what is unsatisfactory. Or you have to retune a circuit to re-establish perfect alignment. During my 25 years of work in home-type electronic equipment, I've been called upon to test and align practically everything electronic. Most of the jobs have been on radio and TV type objects, but there have been all kinds of other jobs from the roof antenna to the living room electronic organ.

The following 199 tests and alignment techniques are a potpourri of what you might be called upon to do. Included are tests and alignment procedures for AM, FM, stereo, monochrome and color TV, auto ignition systems, all kinds of remote control, electronic organs, electronic vocal chords, intercoms, garage door openers, FM converters for TV sets, diodes, zener diodes, varicap diodes, bipolar transistors, JFETs, IGFETs, MOSFETs, multitestors, wattmeters, field strength meters, signal generators, color-bar generators, vectorscope, oscilloscope with high-impedance and demodulator probes, auto timing light, tachometer, transistor and FET testers, and other things.



A book like this would not have been possible without help from various manufacturers. I'd like to thank RCA, EICO, Magnavox and others. I'd like to personally thank Jim Smith, former Chief Field Engineer for Sencore for all his help. I hope these tests and techniques will enable you to perform your electronic chores in a quicker, more reliable and safer manner. Credit is due my son, Denny Margolis, for the cover photography.

Art Margolis

# Chapter 1

## “Tools” For Testing

Your five senses can spot defective electronic equipment on occasion. However, the senses cannot test amps, volts, ohms, microvolts, frequency, watts, peak-to-peak, waveshape, mutual transconductance, beta, bandpass response and other electronic parameters. You must have test equipment to do that. Testing is the only way you can find out if electronic components are satisfactory or not. Testing is not exactly the same as measurement. Measurements tell you precisely how many of a certain parameter are present. During a test you might need to know how many, but it's only to determine the quality of an electronic object.

Alignment is usually needed to adjust the tuning of a circuit. Alignment is also used in testing to determine if an oscillator is creating a good signal and if a circuit is also passing frequencies properly.

Testing and alignment are conducted with various pieces of equipment especially designed for the purpose. There are all kinds of special purpose test equipment, plus certain basic pieces of equipment that are universally used and used more frequently than others. These common pieces of equipment include multitesters, oscilloscopes, tube testers, signal generators, wattmeters, field strength meters, transistor testers, and decade boxes. Then there are all sorts of probes that attach to some of these units such as high-impedance, demodulator and high-voltage types. Test equipment simply “hooks into” electronic gear and measures the electronic parameters, or they produce a signal that can be driven through the circuits. They are the sensors that permit you to examine all the activity in the circuit.

### MULTITESTERS

As the name implies, you can test a multitude of parameters with a multiterster. Popular types are the VOM, VTVM and field-effect multitesters. The VOM is portable and battery-operated. The VTVM is dependent on vacuum tubes (Vacuum Tube Volt Meter) and must be plugged in (Fig. A).



Sencore Model FEZO field-effect multimeter.

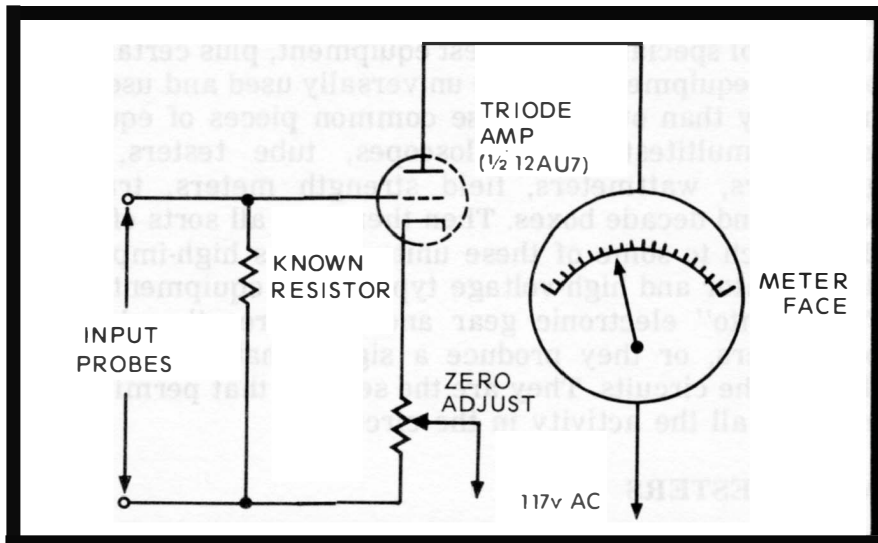
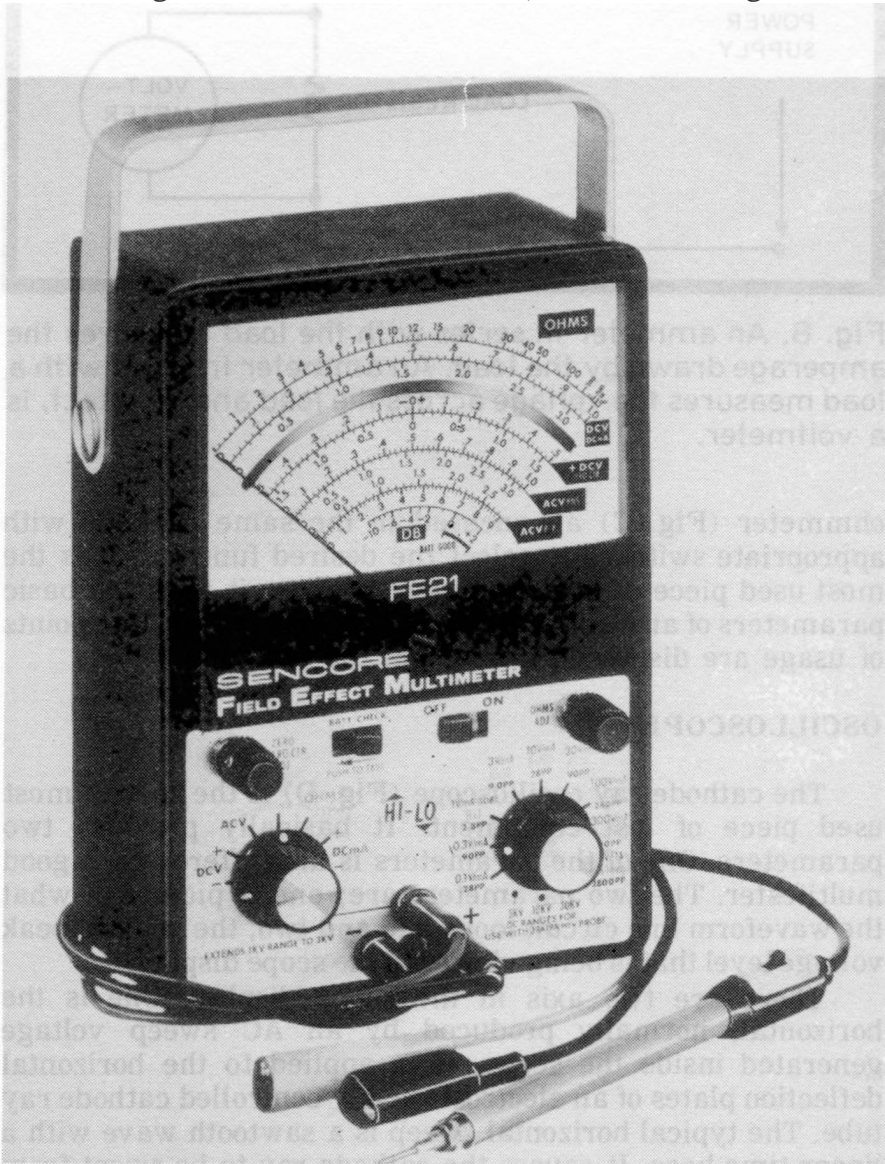

Fig. A. When a triode tube in a VTVM has a voltage input, it causes a proportional change in the ammeter reading in its plate circuit. The triode has a large input impedance so circuits under test are not loaded down.

Field-effect multimeters use FETs in the circuits and come battery- and AC-operated.

The VOM and FET multimeter can test a wider range of parameters than a VTVM. The VOM and FET multimeter can measure volts, ohms, amps and decibels. They also test AC as well as DC. The VTVM tests everything the others do, except for current. There is no amp test available on most types.

No matter how complex they appear, these multimeters are nothing more than an ammeter, voltmeter (Fig. B) and



Sencore Model FE21 field-effect multimeter.



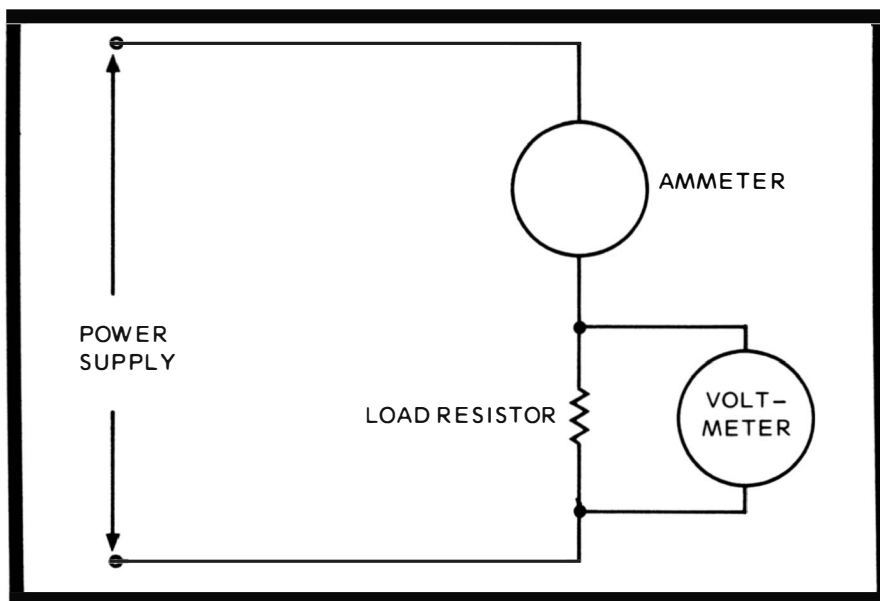

Fig. B. An ammeter in series with the load measures the amperage drawn by the load. An ammeter in shunt with a load measures the voltage across the load and, in effect, is a voltmeter.

ohmmeter (Fig. C) all encased in the same package with appropriate switches to select the desired function. It is the most used piece of test equipment because it tests the basic parameters of an electrical circuit. Actual uses and fine points of usage are discussed throughout the text.

## OSCILLOSCOPES

The cathode ray oscilloscope (Fig. D) is the second most used piece of test equipment. It basically provides two parameters. One of the parameters is also offered by a good multitester. The two parameters are; one, a picture of what the waveform in a circuit looks like and two, the peak-to-peak voltage level that is being viewed in the scope display.

There are two axis in the scope display. One is the horizontal, normally produced by an AC sweep voltage generated inside the scope. It is applied to the horizontal deflection plates of an electrostatically controlled cathode ray tube. The typical horizontal sweep is a sawtooth wave with a linear time base. It causes the cathode ray to be swept from left to right at a uniform rate and then snaps it back at the end of the line to begin again.

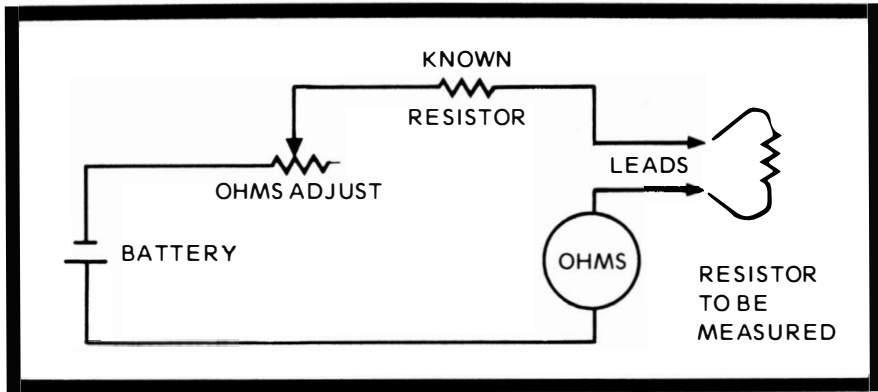

Fig. C. An ammeter in this circuit becomes an ohmmeter and can measure resistance in ohms.

The second axis is the vertical sweep. The signal you want to look at is fed into the vertical input of the scope and is applied to the vertical deflection plates of the CRT. The signal causes the cathode ray to be swept up and down as the horizontal is sweeping back and forth. The resultant waveshape is the desired display.

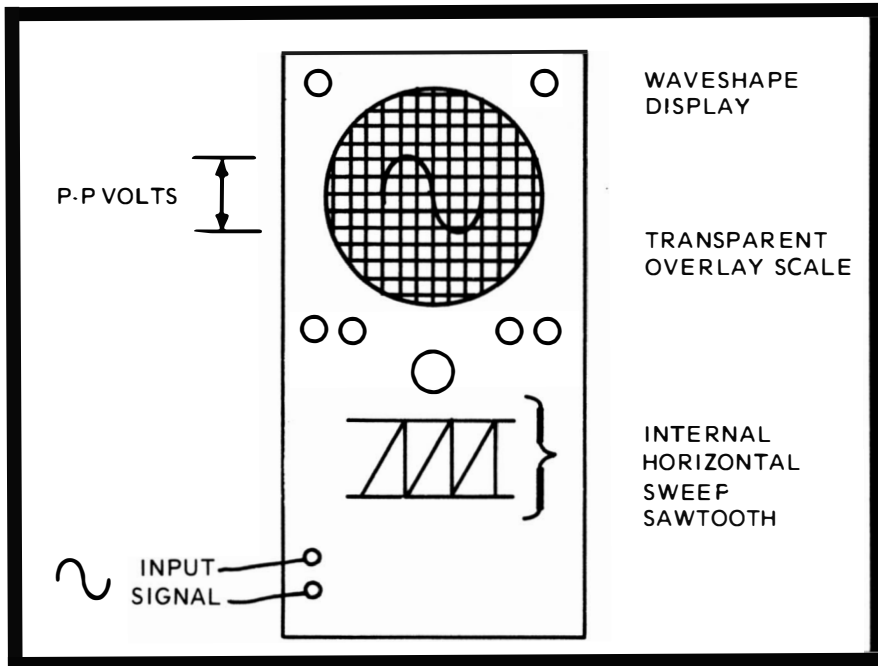

Fig. D. A scope displays circuit waveforms and the amplitude in p-p volts when calibrated.

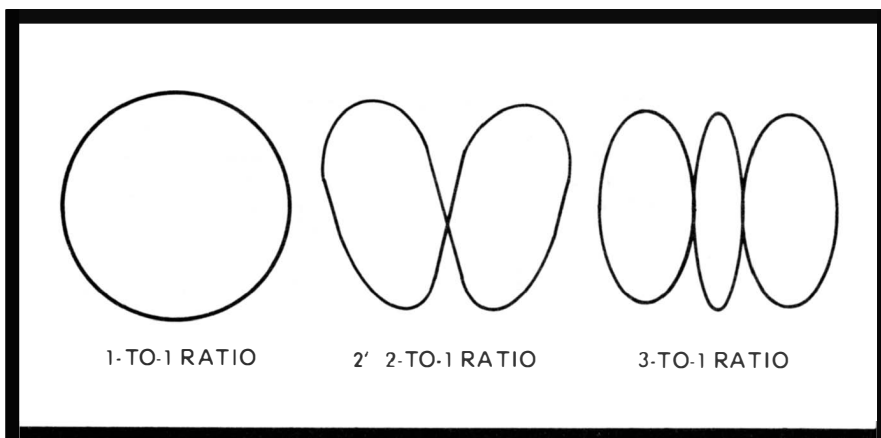

Fig. E. A Lissajous figure scope display reveals the ratio between the input voltage frequencies.

The horizontal sweep can be varied in frequency and also in waveshape by controls on the scope. The horizontal sweep can also be turned off internally and an external horizontal waveshape applied to the horizontal sweep to produce various types of displays. Therefore, the waveshape is available for close analysis and can be the positive indicator of missing or distorted waveforms.

The peak-to-peak voltage of a waveshape can be read directly on the scope screen. Many oscilloscopes provide various controls and even an AC voltmeter, so the exact peak-to-peak value can be easily read. Even on the most economical scope, the peak-to-peak value can be computed easily. Simply take a reference display, such as the 117-volt, 60-Hz line current, and inject it into the vertical input of the scope. Mark the amplitude of the displays as 165 volts peak-to-peak (117v is the RMS value—the effective value). Make the marking directly on the scope face, either with a transparent scale or with a marking pencil. Then compare any other display in relation to the 165-volt scale you have just made.

If you apply sine-wave signals to both the vertical and horizontal inputs of a scope, with all internal sweeps turned off, predictable figures will appear. This is probably the easiest way to gain a good idea of what you are doing with the scope. These figures are named Lissajous figures (Fig. E).

The display they produce is dependent on their relative amplitudes, frequencies and phases. When the phase relationship is exactly 90 degrees between vertical and horizontal and the amplitudes are about equal, the frequency ratio can be read directly from the appearance of the pattern.

When both the frequencies are identical, the vertical will sweep up and down at the same time the horizontal sweeps back and forth, both in a sine-wave fashion. The resultant picture of this one-to-one frequency ratio is a perfect circle. When the vertical input is doubled in frequency in relation to the horizontal, the vertical will appear twice as the horizontal sweeps once. The display will look like a figure 8 lying on its side.

When the vertical is tripled in frequency in relation to the horizontal, the vertical will appear three times as the horizontal sweeps once. The display will have three points along the top and bottom and just one loop along the two sides. If you consider the number of loops along the top and the bottom as the vertical part of the ratio and the number of loops along the side as the horizontal part of the ratio, you can easily calculate a Lissajous figure.

The Lissajous figures are more than just electronic exercises. Using the 60-Hz line frequency, which is a known constant, you can measure frequencies in the audio range by comparing the Lissajous loops you produce on a scope display, using the scope's internal sweep.

## **SIGNAL GENERATORS**

Signal generators are nothing more than test oscillators. They produce audio frequencies, RF frequencies, marker frequencies and so forth. In the audio range, most audio oscillators provide a variable frequency and amplitude output ranging between 20 and 20,000 Hz. A good one produces square waves as well as sine waves.

In the RF range, most generators cover a range between 85 kHz and 40 MHz for AM, FM and CB work. Some produce 19-kHz and 38-kHz signals for multiplex stereo work and TV signals for RF, IF and FM carrier waves. RF generators produce marker frequencies that are high in amplitude and very narrow in width, and so forth, as well as modulated RF signals. Sweep generators provide variable sweep widths up to 12 MHz. The designs are infinite and you must choose your signal generator to suit the job you want to do with it.

The test oscillator can be almost any type. It simply has to produce a signal from an RC, LC or crystal-controlled oscillator. The oscillator signal can be injected into circuits to signal trace or align them. A test oscillator will aid in measuring such parameters as frequency, by comparison on a scope face, and frequency response of a circuit by its appearance on the scope face. It's also invaluable in signal





Sencore Model SM152 sweep and marker generator designed for TV sweep alignment.

tracing, using either a multimeter, speaker or TV CRT as an indicating device. The gain of a stage and the overall gain of several amplifier stages can be measured accurately by taking output readings and comparing them to input readings and various test points along the signal path.

## POWER METERS

A power monitor, such as the Sencore PM 157, measures watts. The power in watts is the result of multiplying current times voltage. The power meter assumes an input voltage of 117 volts and based on this line voltage, reads amperes directly. With a voltage other than 117 volts, the actual power is computed by an accompanying conversion table.

## FIELD STRENGTH METERS

The typical field strength meter has one meter with one scale on it. The scale is graduated in microvolts and decibels,



Marker generator, Sencore Model SM158, provides signals for TV IF, chroma and RF alignment.

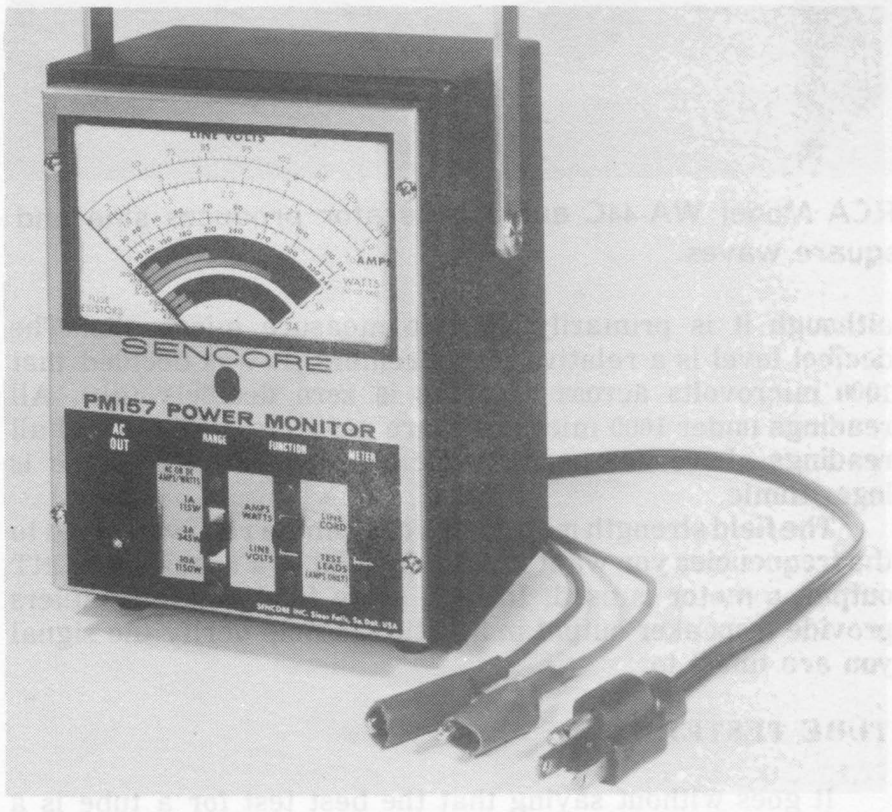

Sencore PM157 power monitor measures line voltage, current and watts.

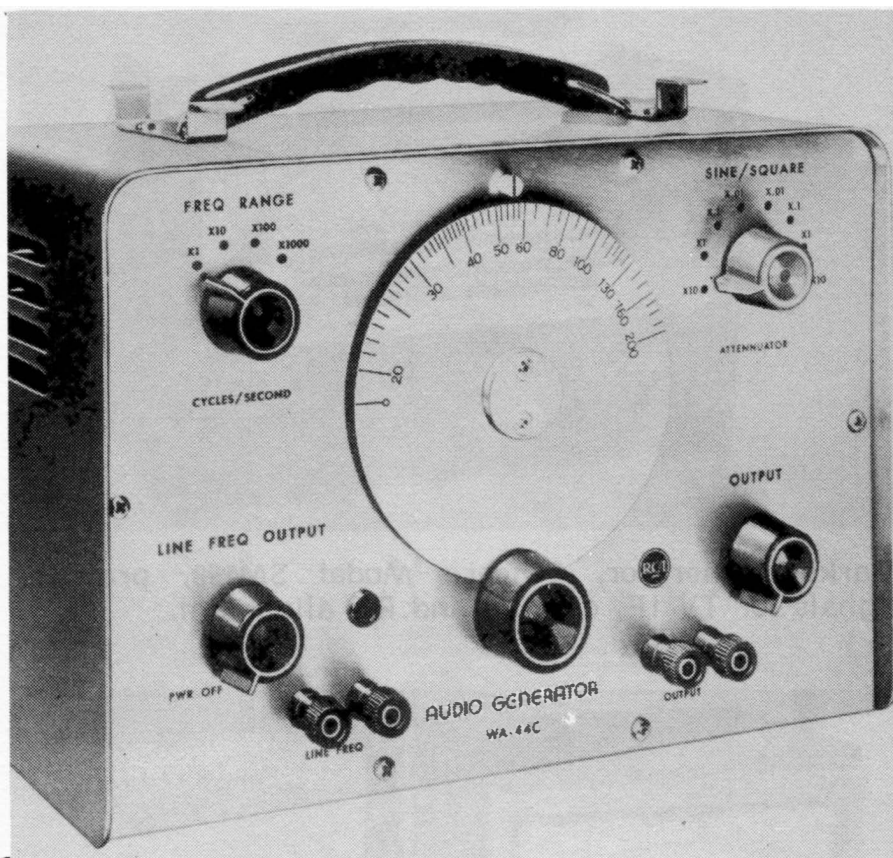

RCA Model WA-44C audio generator produces sine and square waves.

although it is primarily used to measure microvolts. The decibel level is a relative measurement. It was decided that 1000 microvolts across 75 ohms is zero decibels (db). All readings under 1000 microvolts are negative decibels and all readings above are positive decibels. The decibel scale is logarithmic.

The field strength meter is a very simple receiver tuned to the frequencies you want to test. Instead of a speaker or CRT output, a meter is used. In fact, some field strength meters provide a speaker output in addition to help verify the signal you are tuned to.

## TUBE TESTERS

It goes without saying that the best test for a tube is a direct substitution of a known good tube. As a result of this truth, it is a fact that lots of busy electronic shops do not even

have a tube tester on the premises. Others do own one, but they are in a corner covered with dust.

When a tube tester is used in a service shop, it is usually for one reason. A tube is suspected as defective and there is no known good replacement near at hand. The tube tester is then used to determine whether a tube is good or bad.

### Emissions Test

Most testers provide a simple cathode emission test. Whether the tube is a diode, triode, pentode or heptode, it is tested as a diode. For instance, in a tube with a control grid and screen grid, the two elements are tied to the plate (Fig. F). Then, a DC voltage is placed on the plate and current is drawn from the cathode.



Field strength meter for all TV bands and the FM broadcast band. Sencore Model FS134.





Emission-type tube checker also reveals shorts and leakage. Sencore Model TC154.

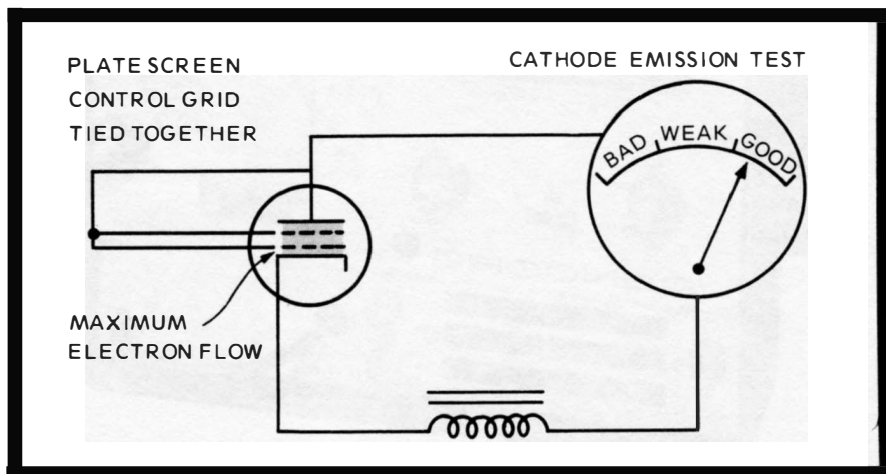

Fig. F. Most tube testers simply measure cathode emission. It follows that other characteristics probably are good if the cathode emission is good.

Without the valve action of the control grid, the cathode runs wide open. The plate absorbs all the cathode current. A DC meter in the plate shows whether the cathode emission is strong, moderate or weak. A strong current flow deflects the meter into the good region. A moderate flow places the needle into the weak, and little or no current puts the needle into the bad section. Green, yellow and red display colors help confirm the good, weak and bad on the dial face. This test, if prolonged, can warp the tube elements and strip the cathode of its emission material.

While this test is far from ideal, it is an adequate go-no go test and is the one performed. It has enough merit to be used in the exceptional cases when the direct substitution test cannot be performed.

### **Gm (Mutual Transconductance) Test**

Another type of tube tester occasionally found in a service shop actually measures Gm in a tube, in a rough manner. Gm is the ratio of the amount of control grid voltage needed to cause a certain change in plate current. In a Gm tester a signal, separate from the applied DC bias, is applied to the tube being tested (Fig. G). This is in triodes, pentodes, etc., not in diodes.

The control grid signal, which is known, produces a change in the plate current. The amount of change, measured in microamps is divided by the control grid signal voltage. The resultant is displayed on the meter in the plate circuit. It is measured in micromhos, the transconductance.

### **Gas and Short Tests**

In most tube testers, the gas and short tests are performed simultaneously. During the test, a high potential voltage difference is applied to different elements of the tube. If there is any gas in the tube, or the control grid draws any current, or if any current flows between elements, an indicator either reads the current in microamps or a neon light winks on. There is an aluminum oxide coating of insulation between the heater and cathode. If it breaks down and allows current to flow, even in minute amounts, a H-K short is revealed. Most testers won't show anything until at least 100 microamps pass from heater to cathode. While this test is also rough, it does provide a certain amount of service information and will on occasion pick out badly leaking tubes.

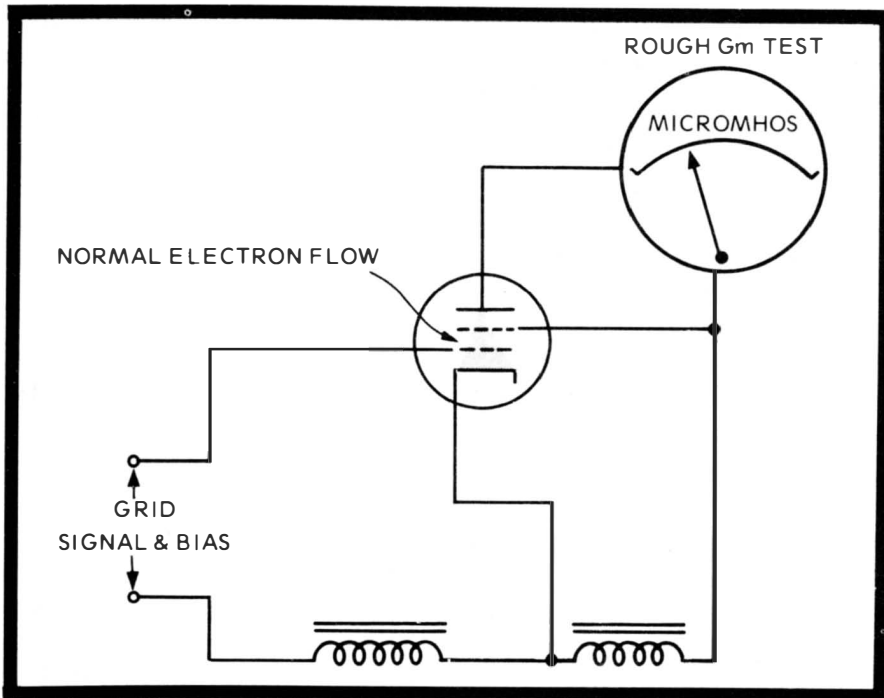

Fig. G. Some commercial testers actually provide a rough Gm test with this basic circuit.

The principle behind tube testers is valid though not unerring. While there are all sorts of tube parameters such as amplification factor, plate resistance, interelectrode capacitance, plate current, grid current, typical element voltages and so forth, in addition to Gm and cathode emission, it is assumed that if the cathode emission, shorts and gas tests are good, the rest of the tube is probably OK, too.

## TRANSISTOR TESTERS

While tube testing is simple, even on the most complex tester, transistor testing is quite complicated. While all tubes operate around the cathode-to-plate electron flow, transistors perform in a multitude of ways. The only real complication to tube testing is the great number of tubes all with different pin numbers. The tube tester solves this complication with numerous tube sockets and a switch.

The pin number complication doesn't exist in transistor testing. There is only E, B and C in a bipolar transistor and S, G and D in a field-effect transistor. Transistors, however, make up for the lack of connection complications by

demanding accurate parameter testing instead of the simple cathode emission type test a tube needs. While a tube is easily substituted in tube sockets, most transistors are best tested in-circuit and have to be carefully unsoldered to remove them from the circuit.

Bipolar transistors have to be tested for DC and-or AC beta. DC beta is the current amplification factor and is the ratio of collector current divided by the base current. AC beta is the ratio of change in the collector current divided by the change in the base current, while holding the collector voltage constant. This current parameter is used in conjunction with bipolar transistors because they are current amplifiers.

A second parameter needed in analyzing a bipolar transistor is the leakage current flow in microamps between the collector and base. It's called  $I_{cbo}$ . These two parameters can be obtained only with a good transistor tester.  $I_{cbo}$  means



Sencore Model TF151 transistor tester designed to check bi-polar and field-effect transistors.



RCA capacitance-resistance substitution decade box.

current  $I$ , between the collector  $c$  and the base  $b$  with the third element left open  $o$ .

In field-effect transistors, which are voltage devices like a tube, not current devices like a bipolar transistor, the main parameter needed is  $G_m$ , the same as a tube. The second parameter,  $I_{gas}$ , which is the leakage current  $I$  between the gate ( $G$ ) and the source ( $S$ ) with the third element ( $S$ ) shorted to the second element, the source.

A third parameter of an FET is  $I_{dss}$ , the zero bias drain current. It is something like cathode emission in a tube. It is the amount of current  $I$  that flows from the drain  $D$  to the source  $S$ , with the third element, the gate, shorted to the second element, the source  $S$ . With the gate shorted to the source, it's like a tube tester shorting the control grid to the plate. Just like the tube, the FET runs wide open with the zero bias.

Another transistor test check is the oscillation capability and how high in frequency it can oscillate. The ordinary transistor tester does not usually provide the test, but a special oscillator circuit can be put together as shown in the text.

## DECADE BOXES

A largely ignored testing technique is that provided with decade boxes. Perhaps it is ignored because it is so simple and when a decade box pinpoints a bad component it's almost like cheating. No technological foreplay is performed. Yet the decade box technique is quite accurate and can perform a test something like the direct substitution of a tube. With a decade box you can introduce substitutes for resistors, capacitors, diodes and filter capacitors. Also, you can add and subtract resistance and capacitance from a circuit.

A decade box is nothing more than a group of commonly used resistors, capacitors and rectifiers, mounted in a convenient box. You can select values at will by the turning switches and pressing buttons. Yes, individual components could also be used, but the convenience of the decade box and its clip leads save all kinds of time. By adding the decade box to your bench and using it frequently, another full dimension of testing by substitution is available.

## Chapter 2

# AM Radio

### No. 1: PEAK IF ALIGNMENT—VTVM

The question of whether or not alignment is needed frequently arises during a radio repair. The radio has lowered efficiency, not enough volume can be obtained. All the stages are operating and normal DC-resistance tests reveal no clues. The IF stage must be checked. It must either be eliminated as a trouble source or the blame pinned on it. Also, the IF transformers, even though they pass the signal and have no continuity defects, could be defective due to a shorted turn or two. An IF alignment will reveal whether or not the IF stage is operating correctly or not.

The only equipment needed is an RF generator and a VTVM. An output meter or VOM can be used instead of the VTVM. The meter, attached across the voice coil (Fig. 1A) of the speaker, is set on the lowest AC scale. A 0.05-mfd capacitor is attached to the signal generator probe. The blocking capacitor is then connected to the RF input of the mixer. In a transistor radio, it is usually the base of the mixer. In a pentagrid converter, it is usually the third grid. The generator negative end is attached to B minus which might or might not be the chassis.

The generator is then turned on with the gain set at minimum. The IF frequency, usually 455 kHz, is selected on the generator tuning dial. Be sure you are tuned to the correct IF. Some radios have 175, 262, and 456 instead of 455 kHz. Check the service notes for the correct IF. Attach a jumper wire across the local oscillator coil. This turns off the oscillator. Otherwise, it will mix with the incoming IF from the generator and the resultant heterodyne produces many frequencies, all unwanted. With such unwanted signals present the IF could be tuned to the wrong frequency.

Next, turn on the radio and allow all the equipment to warm up for 10 or 15 minutes. After warm up, crank the volume control to maximum and begin turning up the gain on the generator. Some volume will be heard in the speaker and the meter needle will move. Use only enough gain to allow a

scale reading about a quarter of the way across the meter face.

Starting with the top slug of the last IF transformer before the detector, adjust it with a neutral “stick,” then tune the bottom slug (Fig. 1B). Adjust for maximum, clearest audio and meter deflection, then go to the top slug of the next to the last IF transformer and repeat the procedure top and bottom. It would be that there are only two IF transformers. If so, that’s the alignment. If there is a third IF transformer, repeat the top-bottom procedure on it.

When the alignment is far off adjustment, the audio and meter reading can become excessive as the correct settings are approached. The meter needle will “pin.” If so, reduce the generator gain so that the needle is down below midrange.

Always repeat the slug adjustments a few times until you know you are obtaining maximum gain. If a transformer won’t tune or produces no effect, you can suspect it as being defective. Also suspect are its adjacent components.

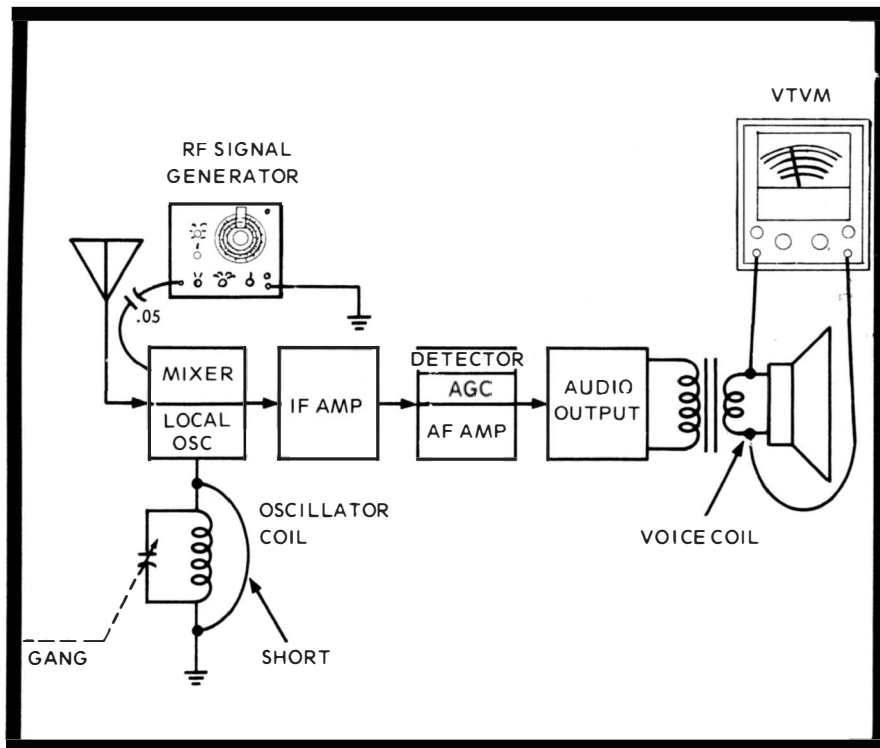

Fig. 1A. The RF signal generator and the VTVM are needed for AM peak alignment. The receiver oscillator should not be running.



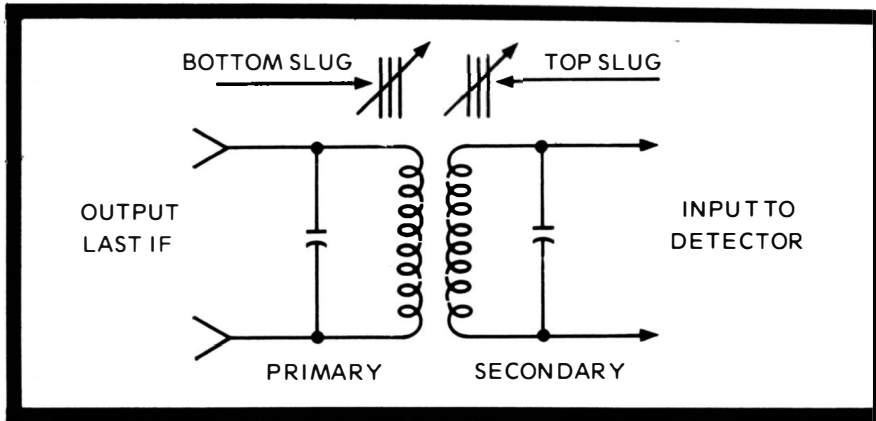

Fig. 1B. The top slug is the secondary and the bottom slug is the primary in a typical IF transformer.

## No. 2 PEAK IF ALIGNMENT—SCOPE

If a radio is squealing and the gain is lowered, a stage is probably oscillating. If the IF response curve can be examined on a scope, valuable service information can be obtained. If the response curve has jagged sides, it means the IF stage is oscillating. Once this is ascertained, the stage can be checked for open bypass capacitors, excessive transistor or tube feedback due to distributed capacitance or slightly incorrect DC resistance. Also during the procedure, you automatically check the quality of the IF section. The IF could simply be out of alignment.

The equipment needed is a sweep generator and an ordinary scope, connected as shown in Fig. 2A. A VTVM could be used on its peak-to-peak scale to determine the response curve voltage, but the appearance of the waveshape can't be seen. The peak-to-peak VTVM reading simply tells you the waveshape's amplitude measured in p-p volts. Also, with the VTVM the response curve can be peaked but aberration in the curve cannot be noted.

The sweep generator probe is equipped with a blocking capacitor, a 470-pf type (Fig. 2A) or thereabouts. The capacitor is attached to the RF input of the mixer. In a transistor radio this point is usually the base of the mixer transistor. In a tube radio it's the third grid of the pentagrid converter tube. The negative lead of the generator is attached to B minus, which may or may not be the chassis, depending on the power supply circuit. The vertical input to the scope is connected across the volume control. The volume control can be set at minimum so no audio is heard if it's desired. (It usually is so it doesn't add

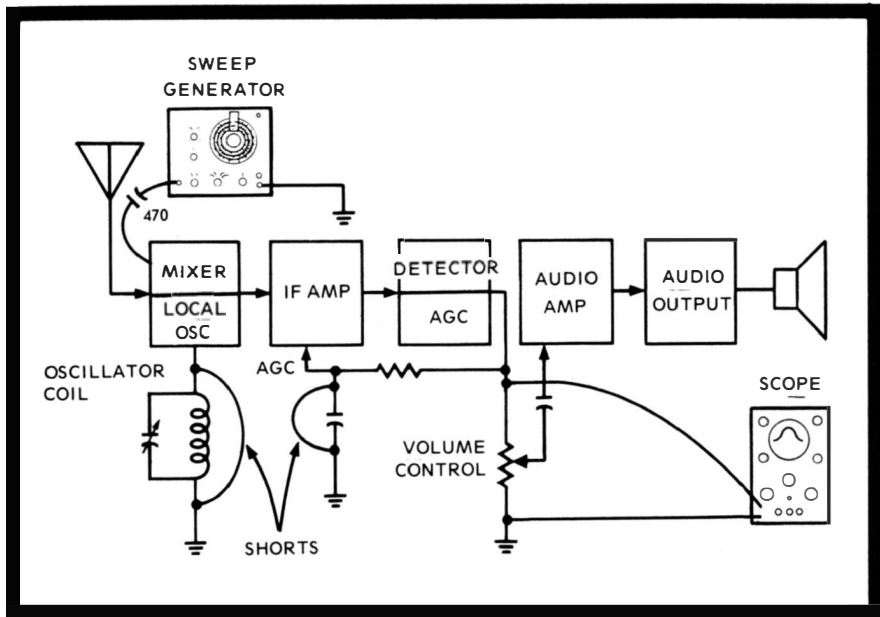

Fig. 2A. A sweep generator and an oscilloscope provide an exact method for AM peak alignment.

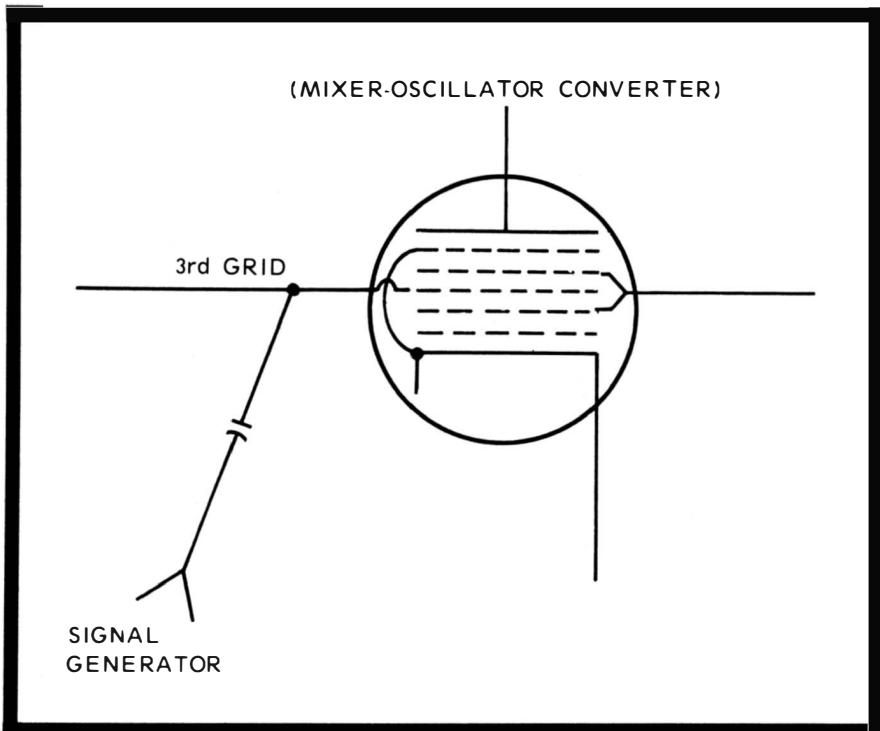

Fig. 2B. Most tube radios use a pentagrid tube for the mixer oscillator function.

to distractions.) If a VTVM is used, it can be attached across the volume control, too.

The local oscillator is shorted out so it stops running. A jumper across the oscillator coil accomplishes this, if the local oscillator is left running, all kinds of heterodyned frequencies will be produced as the generator output mixes with the oscillator frequencies. These are undesirable and will confuse the scope picture. The AGC line coming from the volume control should be disabled by jumping the AGC output to B minus.

The radio, sweep generator and scope are turned on and allowed to warm up for 10 or 15 minutes. The sweep generator center frequency is set at the receiver IF, which is usually 455 kHz. This drives the generator output through the mixer and IF stage. After detection the signal appears across the detector load resistor, which is the volume control. The detected output is applied into the vertical input of the scope. The peak-to-peak voltage developed across the volume control deflects the scope picture vertically.

Next, the sweep is activated and adjusted to about 10 kHz, about the average bandpass of the typical AM IF amplifier. As the input signal is swept around the center frequency, the amplitude will be the greatest at the IF's frequency (455 kHz). On either side of the center frequency, the IF loses gain rapidly. As a result, the sweep scope picture appears as a peak with steep skirts (Fig. 2C).

The scope is adjusted for best brightness focus and just enough vertical and horizontal gain for a good display. The horizontal frequency is then set. Try to get a single response curve. The curve should appear as a peak with skirts. The correct alignment of a small AM radio shows skirts that are not too steep. The curve should be made as high as possible and the skirts should be made as steep as possible. The steeper they are the better the bandpass of the stage. An ideal curve would be a square wave, but this, of course, cannot be attained in a small AM radio. The square wave has a straight-up skirt, a straight-across bandpass response and then a straight-down skirt.

The IF transformers are usually adjusted with a neutral stick as you watch the scope picture. As the slugs are detuned, the response curve flattens out, the amplitude drops and the skirts spread. As the slugs arrive at their correct point, maximum height and steepest skirts are attained. If you see aberrations in the response curve, such as jagged edges (oscillation), wide skirts or low amplitude, there is trouble in the IF stage.

### No. 3: BROADBAND ALIGNMENT—SCOPE

In large, high fidelity radios with an AM band, more times than not there is more than one IF stage. This permits an IF bandpass up to and past 15 kHz. It is generally thought that the AM transmitter sends out modulation only up to 5 kHz. This was true up until a few years ago. Today, lots of AM transmissions are just as high as FM, that is, up to and past 15 kHz. In these better radios, the need quite often arises to check the bandpass and align the IFs exactly as they were designed to be. This is the **broadband** alignment for AM, which is quite a bit more elaborate than the quicker **peak** alignment as covered in tests 1 and 2.

Since there are at least two IF stages and possibly more, the bandpass should be greatly improved. The actual curve can approach a square wave with extremely steep skirts and a flat-top. Each IF stage will pass between 5 and 8 kHz nicely. When the output of the IFs are added together at the end of the IF strip, they can pass the full 15 kHz in almost ideal fashion. This provides AM reception that is exceptional.

A sweep generator and a scope is necessary. The sweep generator is coupled through a .05-mfd blocking capacitor

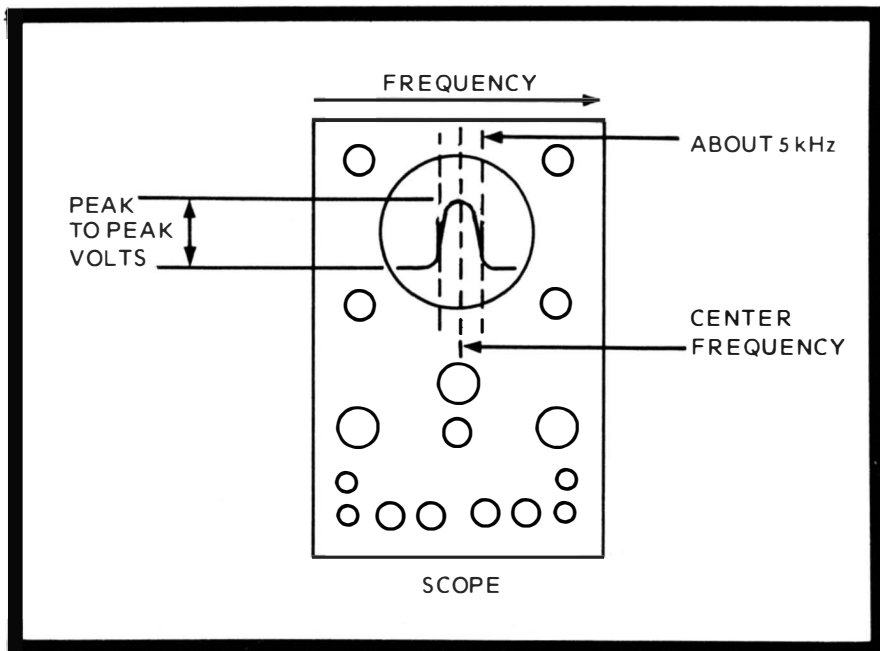
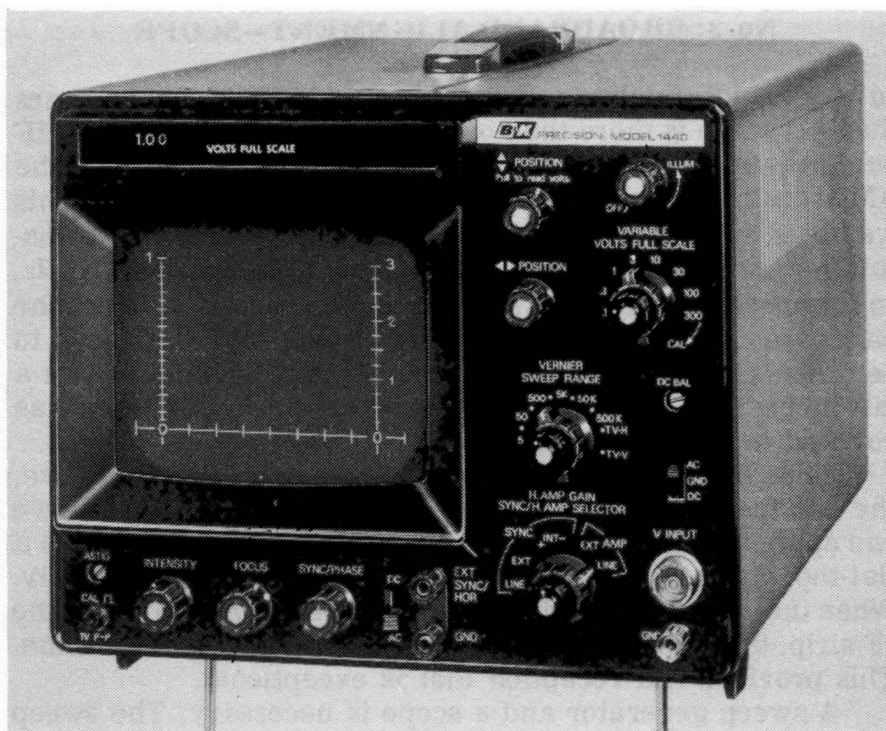

Fig. 2C. The typical IF response curve approaches the ideal, which would be a square wave.



B & K Model 1440 scope, though moderate in price, offers many features including a calibrated vertical sweep.

(Fig. 3A) to the input of the last IF, whether it be the second, third or even the fourth. In a transistor circuit, the last IF input is the base of the last IF transistor. In a tube circuit the input is the control grid. The negative of the generator is attached to the B minus whether it is chassis ground or not. The scope's vertical input is attached across the volume control and the vertical and horizontal gain controls adjusted for a correct display. Adjust the horizontal frequency for one trace.

A jumper is placed across the local oscillator coil (Fig. 2A) and the oscillator stops running so as not to heterodyne with the generator output and produce distracting frequencies. A jumper is placed from the AGC bus to ground. Another jumper is placed across the AM antenna, which in large quality radios could be elaborate affairs.

Turn on the radio, generator and scope and let them warm up for about a half hour. The longer the better. Adjust the sweep width for about 15 kHz. Then readjust the scope until you get a trace that has steep skirts a wide top with a slight

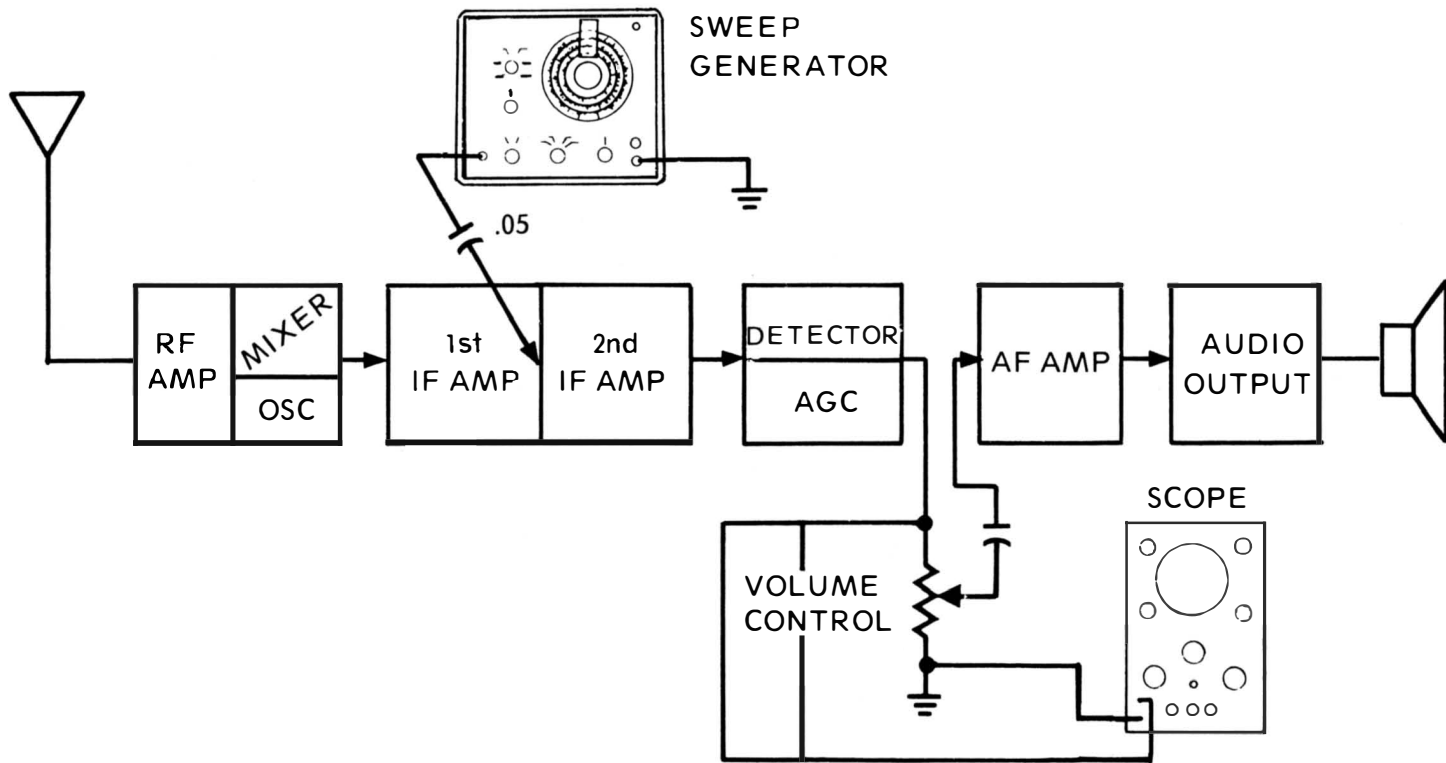

Fig. 3A. A sweep generator and scope are needed for an accurate AM broadband alignment.

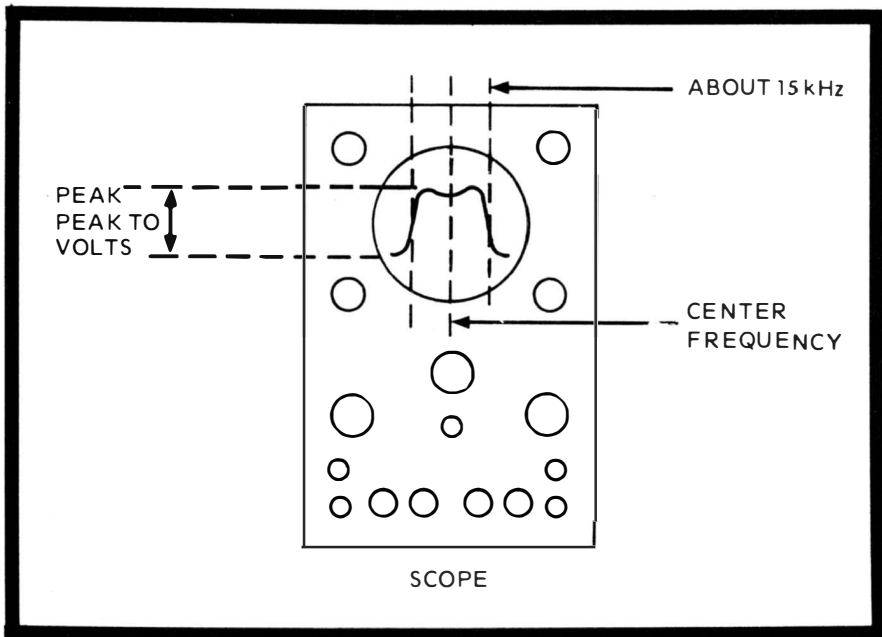

Fig. 3B. The typical AM broadband response curve is 15 kHz wide and approaches a square wave.

ridge in it (Fig. 3B). That's about the correct scope pattern on a multiple IF strip.

Next, align the slug with a neutral stick, secondary first and primary second. Try to improve the curve, but do not let the curve get lopsided (Fig. 3C). On occasion, the curve might look like a single IF curve; that is, a narrow high curve with

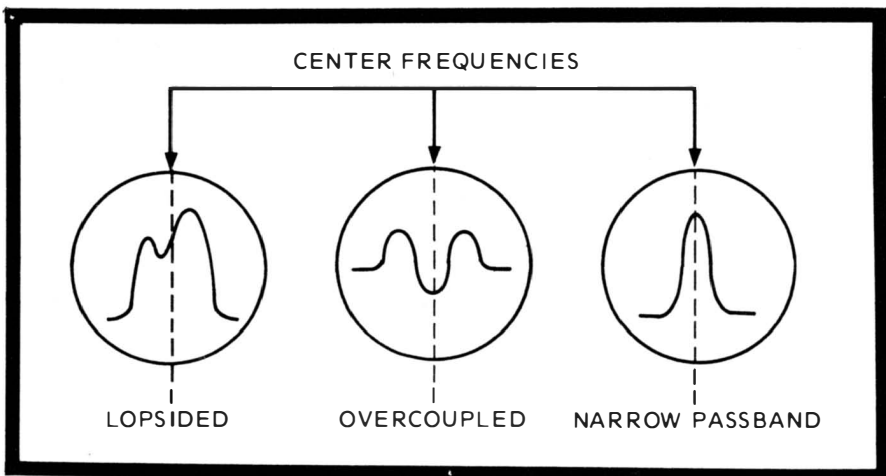

Fig. 3C. All kinds of incorrect response curves appear as the IF transformers are misaligned.

skirts that are not too steep. When this happens, you are aligning all the IF stages at the same bandpass. When they add together they provide a bandpass with high gain but only 5 or 8 kHz wide. Each IF should pass slightly different frequencies and add together to produce a much wider bandpass than a single stage can pass.

When you like the curve adjustments you have made with the last IF, change the generator hookup to the preceding IF input. When you are finished with the last IF, do not touch it again. If you do feel you must touch it, you have to rehook the generator input to it. Do not try to align the last IF with the generator input attached to a preceding IF. Align the slugs in the preceding IF secondary first and primary second. The curve should appear about the same. Keep moving the generator input toward the front end and align each IF in turn. The last IF transformer that is to be adjusted is the input to the first IF. This transformer is adjusted after the generator is attached to the input of the mixer stage. With the oscillator disabled, the mixer stage becomes one of the IF amplifiers.

Sometimes with the oscillator turned off, the mixer stage will provide more amplification than it normally does. When the oscillator is on and heterodyning is taking place inside the mixer, the activity takes its toll in mixer gain. This is accounted for during design. With the oscillator not running, the mixer could cause a lot more amplification. If overload takes place, just reduce the output from the sweep generator.

The above is a general alignment procedure. It is, of course, best to have the actual service notes for the radio and follow the factory outlined procedures, although most will be identical to these. Small differences that are important can be encountered, however.

#### **No. 4: FRONT-END ALIGNMENT—SCOPE**

During servicing of a small AM radio, the need arises to check the performance of the RF amplifier, mixer and local oscillator. They are all tuned circuits and, while they might be operating, they could be doing so at greatly reduced efficiency. The dial might be off, stations missing at one end or other of the band, stations weak at one end or the other of the band, or stations are not being separated from one another. At any rate, after an IF alignment is performed and the equipment still in place, it's a good idea to touch up the front end while you are there.

If the front-end alignment is going to be performed after an IF alignment, as it usually is, as detailed in Tests 1, 2 and 3,



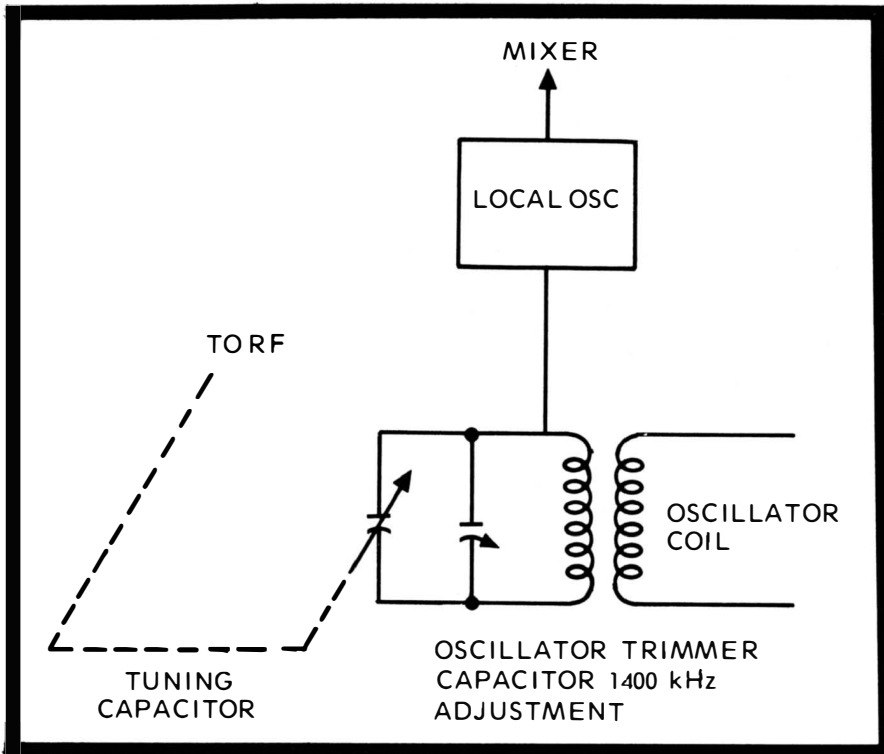

Fig. 4A. The top end of the tuning dial is set by adjustment of the local oscillator trimmer capacitor.

take all jumpers off, such as the ones on the oscillator coil, AGC bus and antenna. Use a 470-pf blocking capacitor in the signal generator input lead. Leave the scope hooked across the volume control. Adjust the scope as mentioned in the alignment procedures above (2 or 3).

Attach the generator through the 470-pf “blocker” to the radio antenna terminals. If the radio uses a loop antenna, place the generator cable next to the radio antenna. The signal will be transmitted directly to the radio with plenty of signal strength.

Warm up all the equipment and turn the radio dial to about 1400 kHz. Then tune the generator to produce 1400 kHz. Electronically, across the oscillator coil, forming a tank circuit, is the oscillator trimmer capacitor (Fig. 4A). Adjust it for maximum peak-to-peak and waveshape on the scope display. Where it produces the best scope picture is the spot that the radio is tuning in the generator output best. The adjustment sets the oscillator at exactly the right frequency so that it beats with the incoming signal to produce the exact IF when the radio is tuned to the high end of the dial.

Next, tune the radio to 600 kHz. Adjust the signal generator to produce a 600-kHz signal. Then, find the RF trimmer which is in the radio input (Fig. 4B). Adjust the trimmer, which is in parallel with the RF tuning capacitor that is ganged with the oscillator tuning capacitor. As you adjust the trimmer, you tune the RF input to exactly 600 kHz.

By adjusting the top end of the dial with the oscillator trimmer and the bottom end of the dial with the RF trimmer, the RF and the oscillator will track quite well over the entire dial. The actual touchup alignment takes only a minute or two, once the equipment is hooked up. The oscillator, when it's misaligned, causes a wrong dial setting for each station.

The RF peaks the gain. With practice it is possible to perform the two touchups by ear, using the speaker and a station at either end of the dial as the signal.

#### No. 5: FERRITE CORE ANTENNA ALIGNMENT

Ferrite core antennas for AM radios are constructed generally and inexpensively on a production line. They are aligned, but the alignment cannot be perfect unless the antenna is mounted in its circuit and aligned along with the antenna trimmer. However, the rough alignment is usually good enough for most

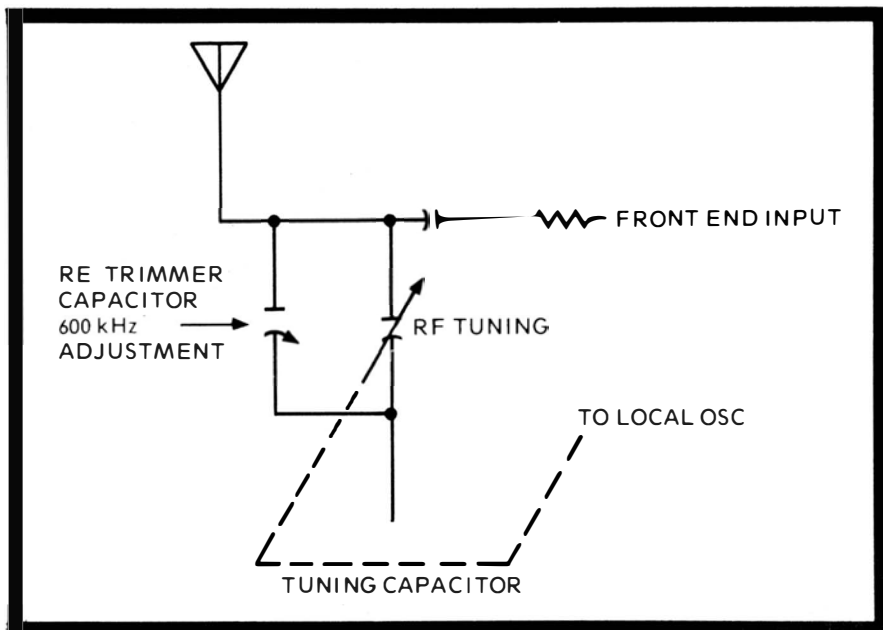

Fig. 4B. The bottom end of the tuning dial is set by adjustment of the RF input trimmer capacitor.

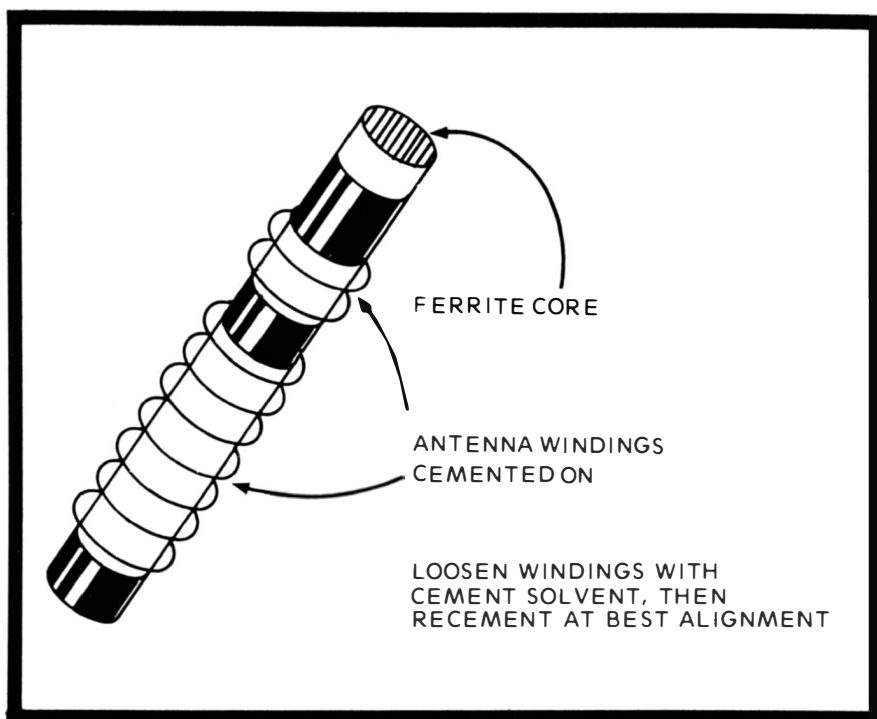

Fig. 5. An AM radio ferrite core antenna is aligned by moving the windings about on the core.

radio applications in strong signal areas. Sometimes, though, the alignment is not satisfactory. The radio is operating well, but just does not have the sensitivity it should have. In that case, it's a good idea to align the ferrite antenna along with the antenna trimmer to achieve peak response.

The alignment consists of getting the best position for the antenna wire on the core, while at the same time adjusting the antenna trimmer capacitor. The positioning of the wire on the core tunes the bottom end of the dial, while the antenna trimmer tunes the top.

Since the wire is cemented to the core, you can't screw the core in and out. You must free the wire with solvent. Once the wire is free, tune the radio to a station near 600 kHz and move the core by hand, inside the antenna, until peak volume is attained (Fig. 5). Then tune the radio to a station near 1400 kHz and adjust the antenna trimmer for peak volume. Repeat the process a few times until maximum reception is attained at both ends of the dial. Then, take some fresh cement and reseal the antenna coil to its core. Quite often you'll find the coil almost in the same spot. A slight difference was the trouble.

## No. 6: TRACKING—SMALL TRANSISTOR RADIO

Tracking is differentiated from aligning, although tracking is usually thought of as an alignment procedure. Tracking generally means that stations tune in at the correct dial settings with equal sensitivity across the entire band. While it is impossible to receive all stations with equal sensitivity, maximum sensitivity can be attained. If a radio's dial settings are not near the correct numbers, the sensitivity will vary across the dial. Commonly, stations will get weak at the top end of the dial or at the middle. Once the tuning system is tracking as closely as possible, the sensitivity will be at maximum.

To set up tracking, there are only a few adjustments and they are quick. Some technicians use the nearest fluorescent light as an all-frequency signal source. The light provides static, and the tracking adjustments are tuned for maximum static (Fig. 6).

The radio is first set near the low end of the dial, such as 600 kHz, and the volume control is turned all the way up. The

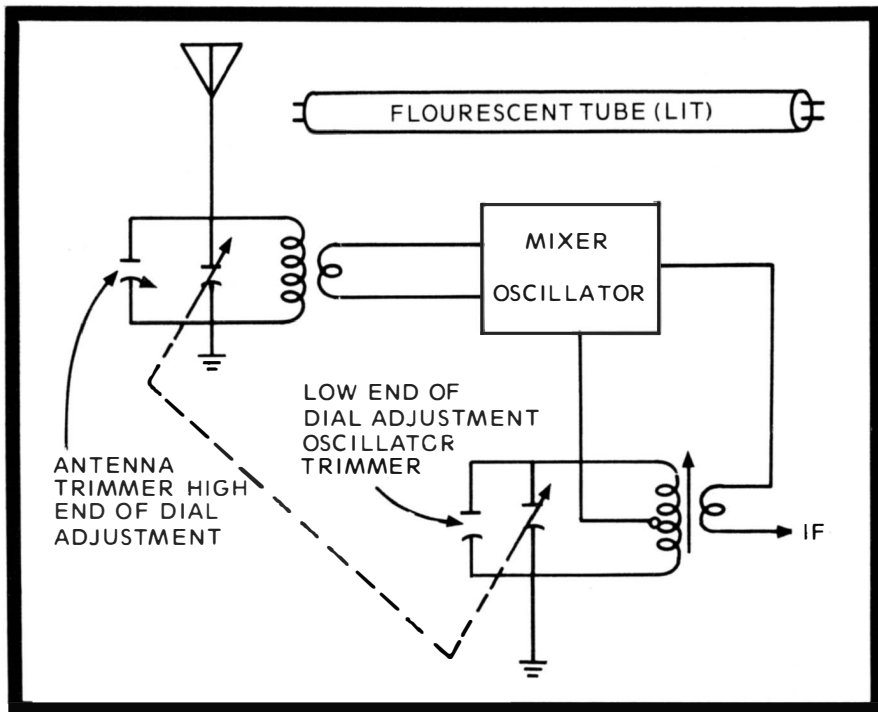

Fig. 6. An AM radio tuning dial can be aligned by using static from a fluorescent light as the signal.

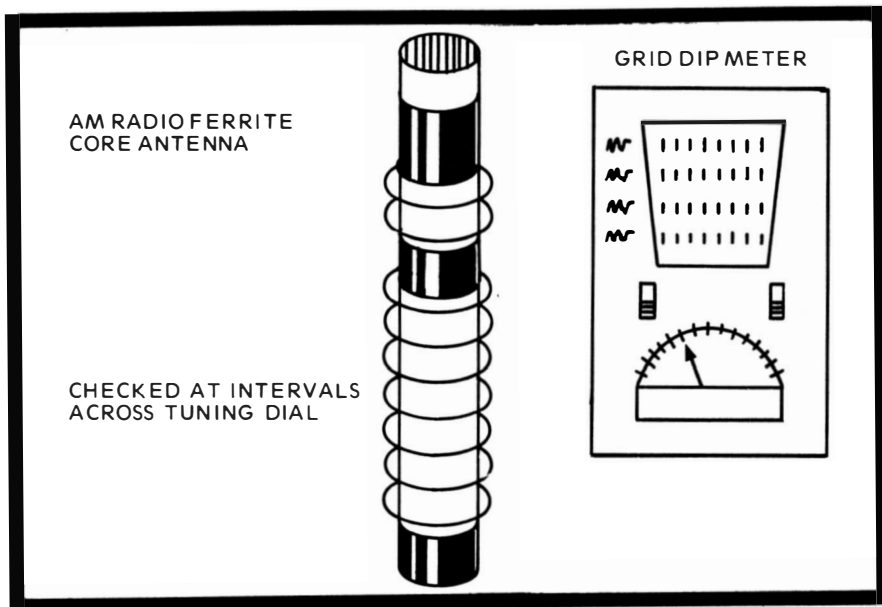

Fig. 7. A grid-dip meter is used to check the tuning of an antenna. At the tuned frequency the needle dips deep.

noise source is approached until a low amount of noise is heard in the radio. Then the oscillator trimmer is adjusted for maximum noise. The radio is tuned to about 1400 kHz. Then the antenna trimmer is adjusted for maximum noise. Perform the adjustments a few times for best results.

The oscillator trimmer is in parallel with the oscillator tank. The antenna trimmer is in parallel with the antenna tuned input circuit. If the adjustments won't help, you need more sophisticated tracking. Most times it works, though.

#### **No. 7: GRID-DIP METER ANTENNA TEST—SMALL TRANSISTOR RADIO**

A small AM radio can be pulling strong signals perfectly, but weak stations are missing. Yet, the radio does not appear to have any problems. This can occur when the antenna and the antenna capacitor don't match. The trouble is usually a defective antenna.

With a grid-dip meter like the Eico 750, capable of tuning the AM range between 500 and 2000 kHz, a check of the antennas receiving ability across that range is possible. A grid-dip meter provides a meter reading when it is placed near a tuned circuit. The meter has an internal oscillator, and when a nearby tuned circuit absorbs some of the energy, the meter needle dips.

The grid-dip meter is placed near the radio antenna (Fig. 7) and is turned on. The radio is first tuned near the low end of the dial. The grid-dip meter is tuned to the same frequency and “rocked” around that frequency while its indicator is observed. If the meter dips, the antenna is absorbing energy at that frequency.

The same procedure is used for various frequencies up and down the dial. For instance at 750 kHz, 1000 kHz, 1250 kHz and 1400 kHz. If the meter dips noticeably the antenna is good. If it doesn't, the antenna is defective and needs replacement. The antenna will not track.

### **No. 8: LOCAL OSCILLATOR TEST—TRANSISTOR RADIO**

The common transistor radio is a superheterodyne and as such has a local oscillator to produce the heterodyne frequency. During servicing it is useful to quickly determine whether the oscillator is running or not. There might be static but no reception. If the oscillator is not running, the tuned in RF signal is passing through the IFs and is trapped out.

A typical oscillator-mixer circuit is called an **autodyne**. It uses one transistor to perform both the oscillator and mixer jobs. Some of the oscillator energy from the collector can be fed back to the emitter or base. This continuing energy starts and sustains the oscillator with steady feedback pulses. The oscillator is tuned and tracks with the incoming RF, operating either 455 kHz above the RF or 455 kHz below at all times. The RF and oscillator frequencies are mixed in the transistor and the difference tapped off and sent to the IF.

In order to tell whether or not the oscillator is running, the bias between the emitter and base must be monitored. This is accomplished by attaching the VTVM across the emitter and base (Fig. 8). The actual voltage measured is meaningless. Just set the meter for a reading. It will be very low, of course, under a volt, but check it against the schematic to be sure it's about correct. Then turn the tuning capacitor from one end to the other. If the oscillator is running, the voltage will change. If the oscillator is not running, the voltage will remain fixed.

### **No. 9: LOCAL OSCILLATOR TEST—TUBE RADIO**

Most tube radios operating in the AM band use a pentagrid converter tube for both oscillator and mixer functions. There

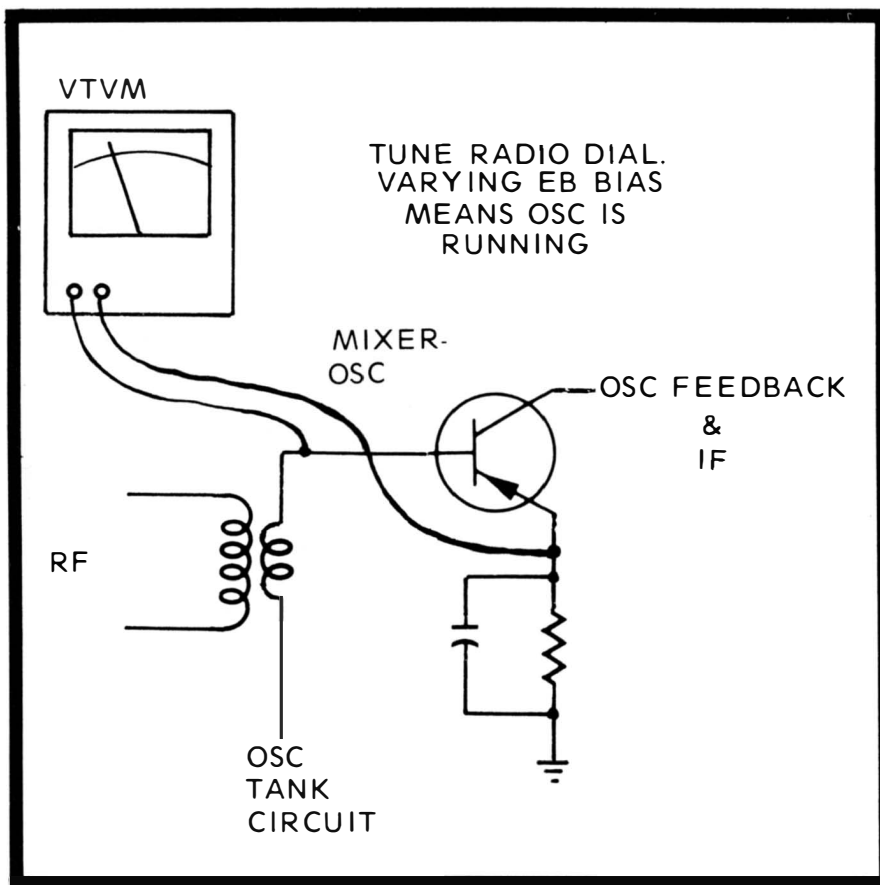

Fig. 8. The local oscillator is running when a VTVM shows a varying bias as the tuning dial is tuned.

are actually two control grids and two screen grids in an otherwise ordinary pentode. One control grid acts as the RF input and the other control grid injects the oscillator signal into the electron stream. The two beat together and the difference is usually the 455 kHz IF.

The oscillator grid usually is tuned by the oscillator tank coil. The tank gets some feedback typically from the cathode. The plate output is not used because it is attached to the IF circuits. As the oscillator fires up from the cathode feedback and continues running at its tuned frequency from the feedback, a large negative voltage is developed across the oscillator grid resistor. If the oscillator is not running, there is no voltage developed across the grid resistor.

It is a simple matter to connect a VTVM's positive lead to the chassis ground and the negative lead to the oscillator

control grid of the pentagrid tube (Fig. 9). According to the actual value of the grid resistor, a voltage of between minus two or minus eight will be found when the oscillator is running. If the voltage is zero or positive, the oscillator is not running.

### No. 10: IF OSCILLATION TEST—TRANSISTOR RADIO

Sometimes after an IF transistor has been replaced, or even if an IF transistor is good, the radio sometimes squeals badly. Nothing else seems to be wrong, but the annoyance cannot be stopped. A prime suspect in such cases is the invisible distributed capacitance between the collector and base of the transistor, which is feeding back some of the collector signal

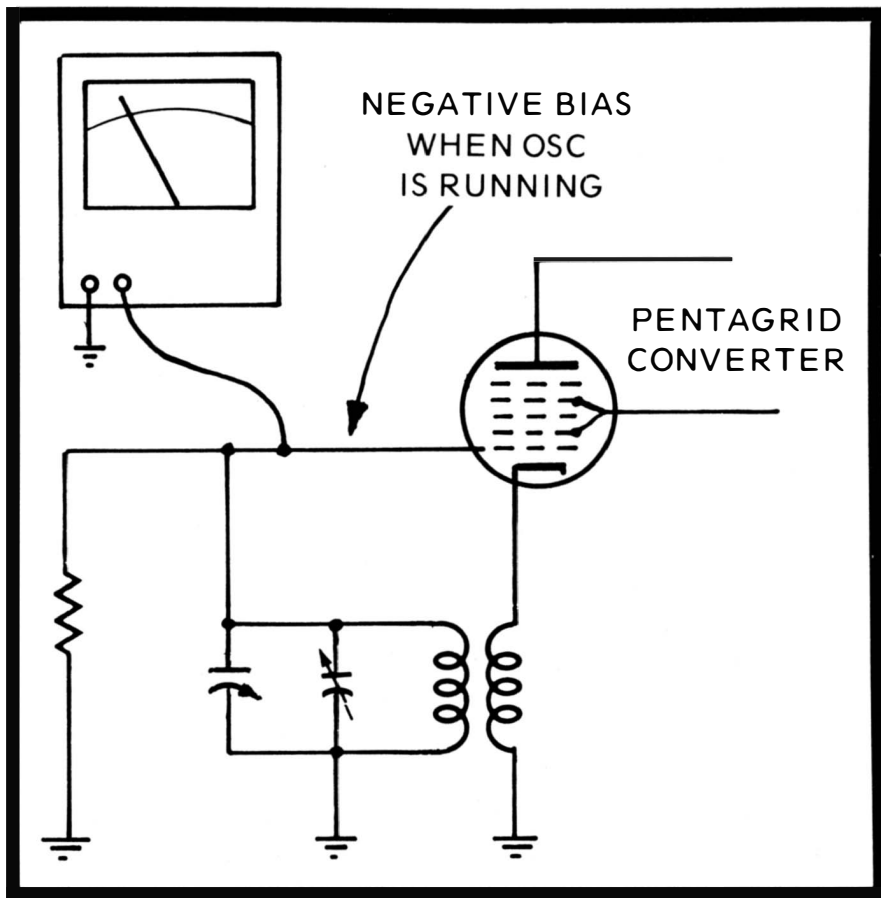

Fig. 9. A tube oscillator circuit is running when there is a good negative bias on the control grid.



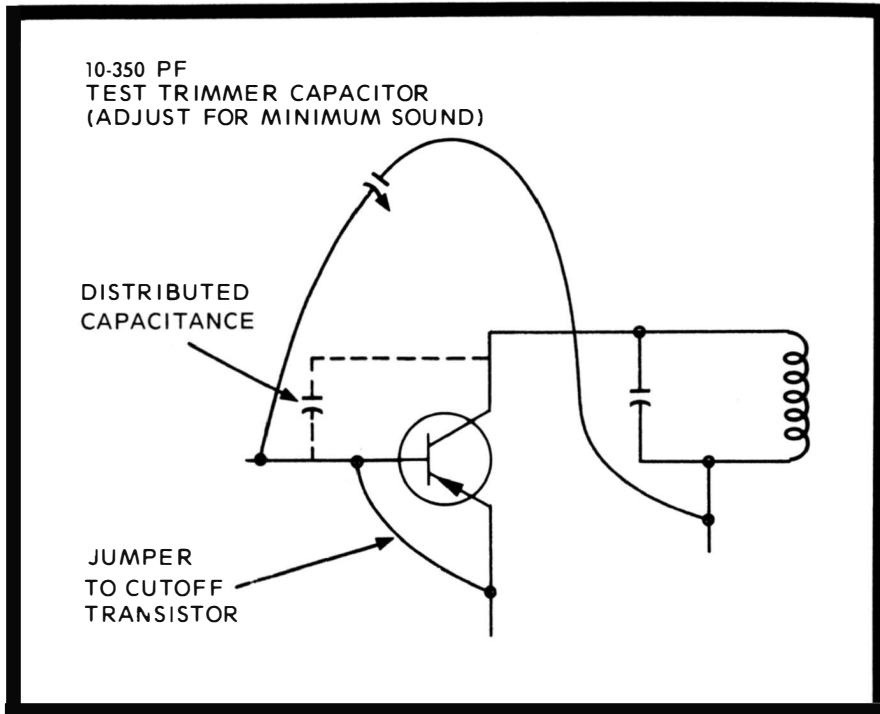

Fig. 10. When a transistor radio whistles and this test kills the whistle, the IF amplifier was oscillating.

to the base and is creating unwanted oscillation. The invisible capacitance can't be removed, but it can be neutralized. That will stop the oscillation and restore good reception. This, of course, will not be the trouble, but the neutralizing procedure will eliminate it as a suspect.

The idea is to stop conduction in the IF transistor and let the signal pass through the distributed capacitance. Set the signal generator around 1000 kHz and connect it to the radio. Take a jumper lead and short out the IF transistor, emitter to base. This kills the forward bias and the transistor cuts off.

Turn on the equipment, tune the radio for 1000 kHz and listen for the generator signal in the radio output. Adjust the volume control for a comfortable level.

Then connect a variable capacitance, like a 10-350 pf, from the bottom of the IF output transformer to the base (Fig. 10). Adjust the trimmer for minimum sound. Maybe it will disappear altogether. Leave the trimmer in the circuit or replace it with a fixed capacitor comparable to the value of the trimmer setting.

## No. 11: AGC TEST

The service notes on many small AM transistor radio are not always available, but most of the circuits are straightforward and almost identical to most other transistor radios. There are set rules and once you determine whether a transistor is an NPN or a PNP, you can quickly figure out generally what voltages should be present on particular test points.

This is not as true in the AGC circuit. The AGC output has to be a DC voltage, either negative or positive. The AGC is negative when it is applied to the base of an NPN transistor, since the NPN current flow is from emitter to base and collector, like the electron flow in a tube is from cathode through the control grid to the plate.

The AGC is positive when it is applied to the base of a PNP transistor, since the current flow is opposite to that of an NPN and a tube. In either case, the AGC affects the E-to-B bias and adjusts according to the incoming signal. Should the AGC be applied to an emitter, the exact opposite is true. It's positive for an NPN and negative for a PNP.

It's hard tracing the AGC through the tiny radio, so it is a good idea to have a quick way of seeing if the AGC is positive or negative at a glance so you may test for its presence.

The AGC is taken from the detector output, so look at the detector diode. It is rectifying the carrier. If it rectifies the positive half of the carrier, the AGC is positive. If it rectifies the negative half, the AGC is negative. Look at the diode polarity. If its cathode is attached to the AGC line, it's positive. If the anode is, the AGC output is negative (Fig. 11).

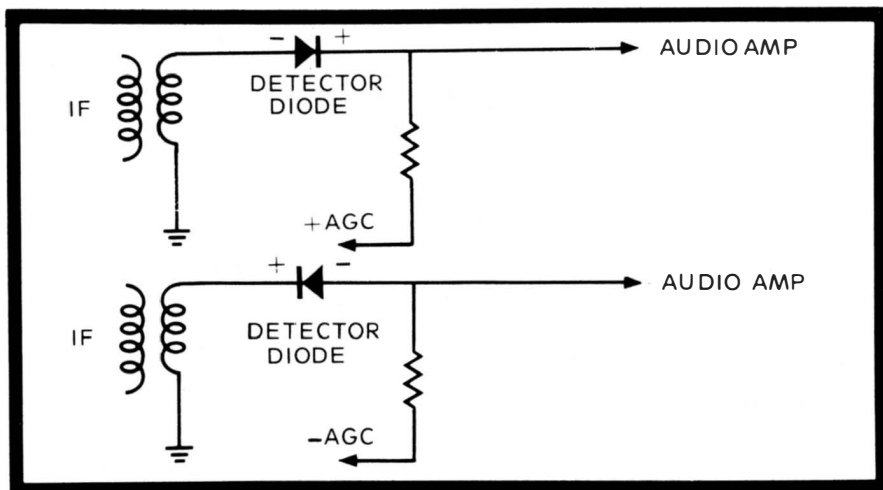

Fig. 11. You can tell if the AGC is positive or negative by observing the polarity of the diode attached into the AGC.

# Chapter 3

## FM Radio

### No. 12: DISCRIMINATOR ALIGNMENT—FM RADIO

During an FM radio repair made on the bench rather than in the field, it is a good idea to quickly align the discriminator. It is a rare radio indeed that will have a perfectly aligned discriminator after a few years of service. Even though other troubles must be corrected, the end of the repair should be a check of the receivers alignment. A misaligned discriminator causes loss of volume, blurred audio and possibly squeals and buzzes.

In order to properly set up the discriminator curve, you really must see it, rather than watch a VTVM produce a reading of the peak-to-peak output voltage. A sweep generator and a scope are needed.

The scope is hooked across the volume control (Fig. 12A). The signal generator is set at the IF, which in most FM radios is 10.7 MHz. The IF is swept at 200 kHz in most radios, but be sure to check the manufacturer's service notes, since on occasion the IF is not 10.7 MHz and the sweep is not 200 kHz.

The generator cable is attached to the input of the limiter, which is found before the discriminator; if the discriminator is actually a ratio detector, the generator input is attached to the input of the last IF stage. The limiter is an IF stage that performs limiting duty in addition to IF duty.

Whether the circuit is a true discriminator or a ratio detector, the alignment procedure is similar. The local oscillator is turned off by attaching a short across the oscillator coil. That way no heterodyning takes place and no 10.7-MHz signal can be developed to interfere with the signal generator input signal. All equipment is turned on and warmed up for a good half hour. The volume on the radio can be turned all the way down if you wish to avoid distraction.

The scope displays the signal developed across the volume control to drive the vertical input. This is the actual detected AF produced in the sweep section of the generator. The generator is sweeping 200 kHz 60 times every second at a certain p-p voltage. The scope uses its own internal sweep for horizontal deflection. If you set the scope horizontal sweep frequency, you'll see a single line diagonally across the scope

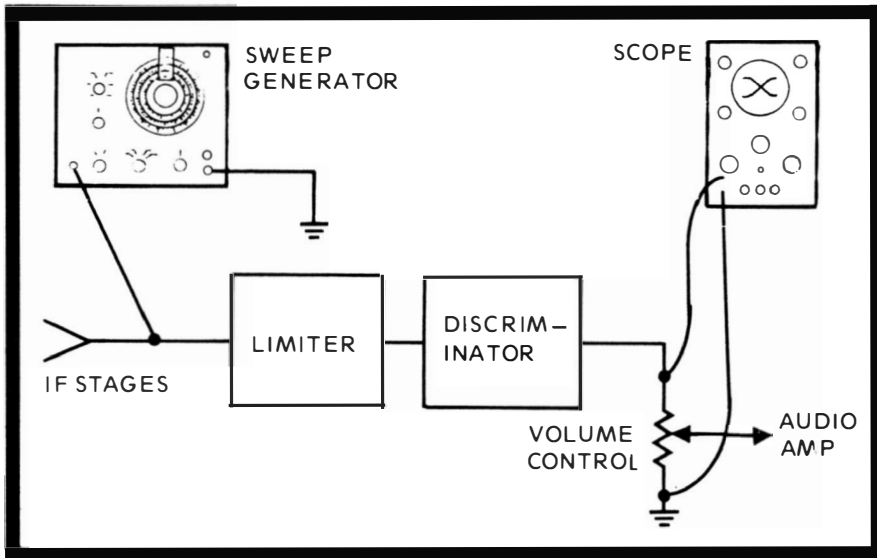

Fig. 12A. Discriminator alignment hookup is simple and requires only a sweep generator and ordinary scope.

screen as the detector output goes from minimum peak to peak to maximum in one of the 60-Hz intervals (Fig. 12B). This is the well known discriminator curve.

In the discriminator transformer there are two cores. One slug, the secondary, adjusts the center frequency of the curve.

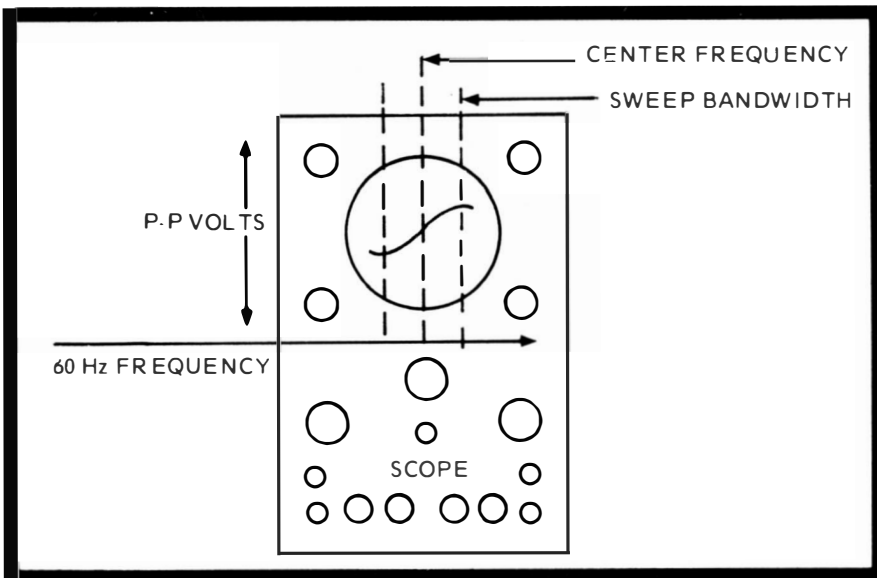

Fig. 12B. The discriminator curve is a picture of the generator sweep as it appears across the volume control.

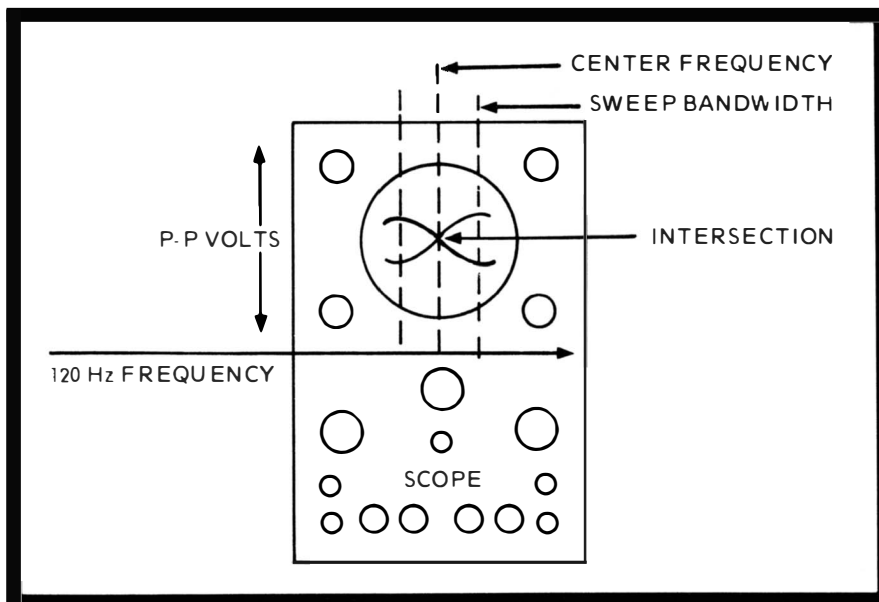

Fig. 12C. A trick to achieve closer discriminator alignment is to double the scope's horizontal frequency.

The center frequency is 10.7 MHz before detection, but after detection it is the zero point between the minimum sweep and the maximum sweep. You adjust the secondary slug until the center frequency looks good and symmetrical between the minimum and maximum points. Then, you can adjust the primary core by watching the linearity and shape of the curve. It approaches an S shape lying over on its side at about 45 degrees.

If you understand what the discriminator curve represents, you can take it one step further and employ a trick to get an on-the-nose alignment. This is accomplished by changing the horizontal scope sweep to 120 Hz. This puts two segments of the response curve on the scope face, one on top of the other, forming an X. There are now two slanted S curves, one in each direction. When the secondary or top slug is adjusted the intersection of the two curves will move. They should be set where they produce a symmetrical X with the intersection at dead center (Fig. 12C).

When the primary or bottom slug is adjusted, the curves are straightened out, resulting in a good linear X. At the best looking X, the primary is set on the nose. Actually, the secondary slug sets up the proper phase of the signal. When the slug places the intersection of the X at the linear center, the zero part of the curve is right on the center frequency. This

places the discriminator right on phase where there is equal peak-to-peak voltage on both sides of the center frequency.

Ratio detector alignment is practically identical to discriminator alignment. You could set the sweep a bit further out than that used for discriminator alignment so the curve will tail off quickly and clearly delineate the ends of the curve. Also, you could purposely detune the secondary so the linearity shows up clearly as you tune the primary. Otherwise, the alignments are identical.

### No. 13: IF-LIMITER ALIGNMENT

FM stations are permitted to transmit a deviation of plus or minus 75 kHz in comparison to the AM maximum of about 15 kHz. An FM radio takes advantage of this wide frequency swing by passing through its IFs a band of about 150 kHz. Not all FM radios do this, but even the cheapest ones pass at least 50 kHz. A check of the bandpass capabilities of an FM radio is

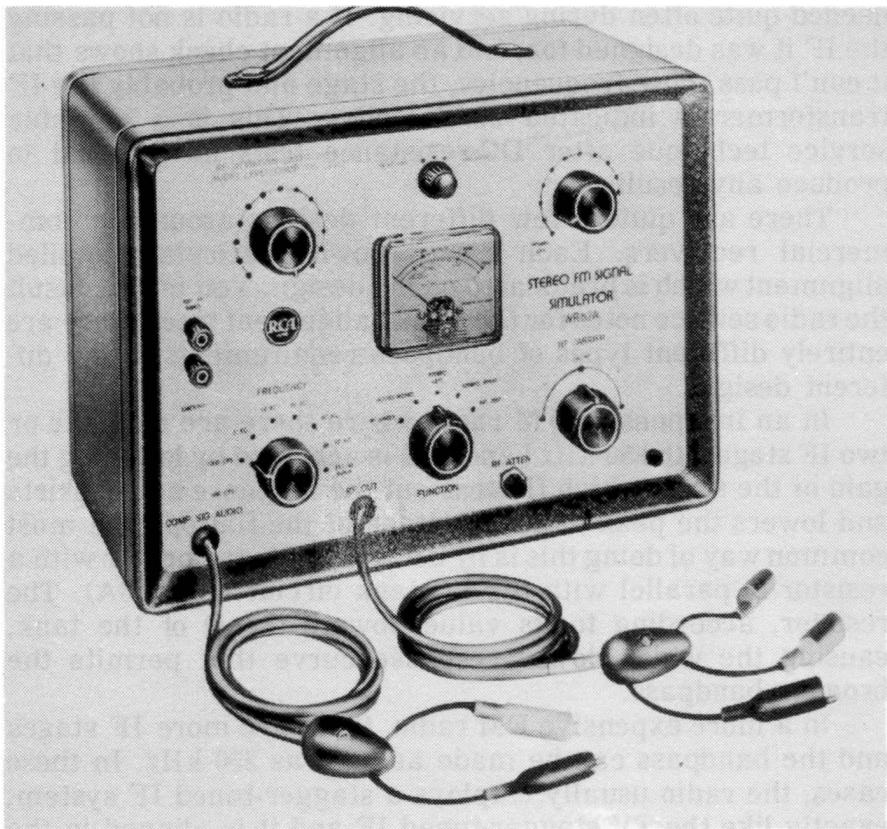

Stereo signal generator, RCA Model WR-52A.

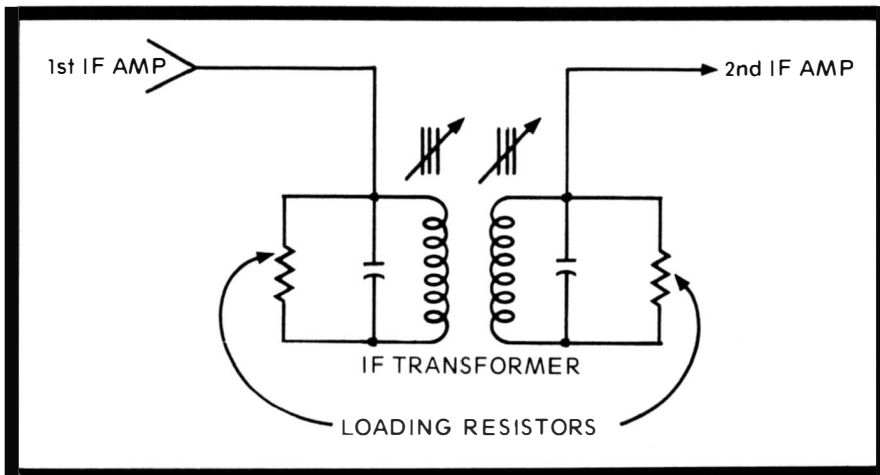

Fig. 13A. The Q of an IF transformer can be lowered to permit additional bandwidth by adding resistance.

needed quite often during servicing. If a radio is not passing the IF it was designed for, and an alignment check shows that it can't pass those frequencies, the stage and probably the IF transformer is indicated as defective. This is a valuable service technique after DC-resistance tests have failed to produce any results.

There are quite a few different designs around in commercial receivers. Each has its own particular detailed alignment which is predicated on the design. You must consult the radio service notes for the actual alignment since there are entirely different types of bandpass requirements in the different designs.

In an inexpensive FM radio where there are only one or two IF stages, the 50-kHz bandpass is achieved by lowering the gain of the stage which flattens out the response curve skirts and lowers the peak-to-peak voltage of the flatter. The most common way of doing this is by using an IF transformer with a resistor in parallel with the LC tank circuit (Fig. 13A). The resistor, according to its value, lowers the Q of the tank, causing the wider, lower response curve that permits the broader bandpass.

In a more expensive FM radio, there are more IF stages and the bandpass can be made as high as 250 kHz. In these cases, the radio usually employs a stagger-tuned IF system, exactly like the TV stagger-tuned IF and it is aligned in the same way. (See the TV stagger tuned IF alignment discussion.)



Even though the wideband IF has its particular quirks according to the actual receiver, there is a general alignment procedure. If there is a limiter stage, peak alignment adjustments are made by attaching a scope or VTVM across the limiter input and adjusting the IFs for maximum voltage output.

The sweep generator is attached into each IF input in turn (Fig. 13B). The sweep is set for whatever the manufacturer calls for from 50 kHz up. Each stage is aligned by adjusting, first, the secondary slug and, second, the primary slug for peak voltage. Each stage is aligned all the way down to and including the mixer. The local oscillator is turned off, as in all the other similar alignments, by shorting out the oscillator coil.

Another way is to connect the VTVM across one side of the ratio detector. You'll see either a positive or negative voltage; it doesn't matter which. Then, align all the IFs in turn until you get the best available peak reading. This reading will be a result of the best response curve.

#### No. 14: RF-OSCILLATOR ALIGNMENT

The FM tuning dial is very critical and many dials read incorrectly to some degree. It's best not to try to restore precise

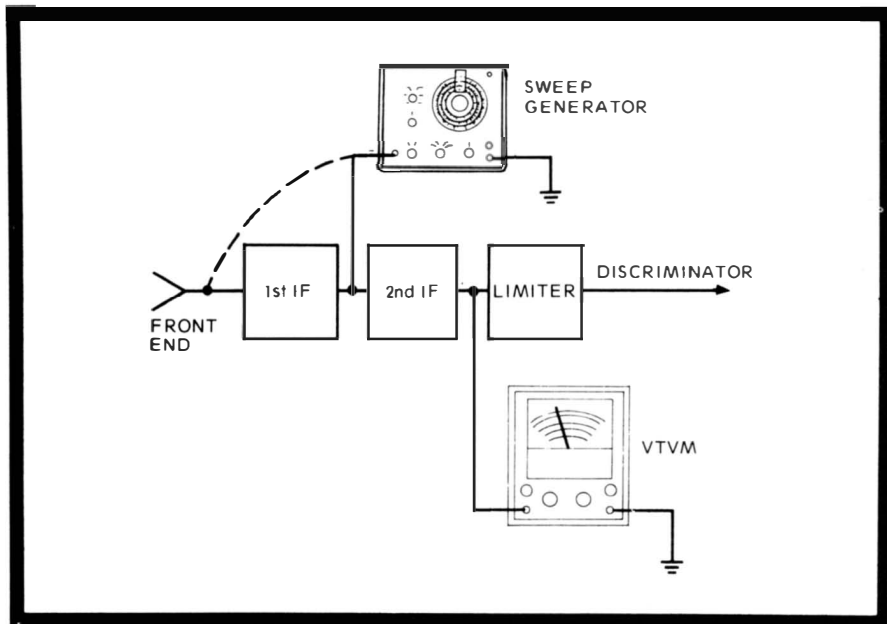

Fig. 13B. The limiter in an FM radio can be aligned by adjusting for the peak voltage amplitude on a VTVM.

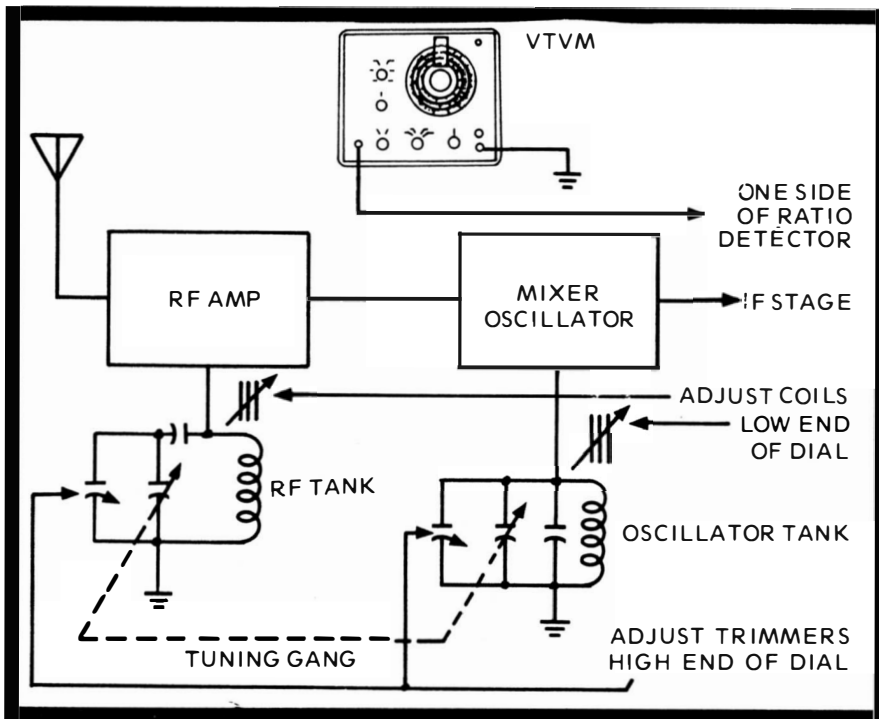

Fig. 14. The coils in the FM front end adjust the low-end dial setting while trimmers adjust the high end.

settings. Simply note that they are slightly off. Alignment should be performed, though, if one end of the dial or the other has lost gain. Then, alignment is necessary. When you finally decide to do an alignment, remember that the smallest turn of a screw is critical.

Do not short out the oscillator coil. The oscillator must be running since it is one of the circuits that will be aligned. The sweep generator is turned on and set at the FM frequencies between 88 and 108 MHz. The sweep is set at the manufacturer's recommended bandwidth, which is any where from 50 kHz to 300 kHz. The VTVM is placed across one side of the ratio detector and either a negative or positive voltage is obtained.

The radio is tuned to 90 MHz and the sweep input set at the same frequency. Then the coils in the converter and RF circuits are adjusted for maximum detector voltage. This sets up the low end of the dial.

Next, the radio and generator are tuned to 107 MHz. The two trimmer capacitors are adjusted in the converter and RF tank circuits. At maximum voltage, the high end of the dial is set up. In both cases, adjust the converter tank circuit first and then the RF tank circuit (Fig. 14).

## FM CONVERTERS

There are all kinds of electronic gadgets around the home and one such interesting piece is an FM converter that attaches to a TV set. The FM band (88 through 108 MHz) lies directly above TV Channel 6. In other words, Channel 6 ends at 88 and the FM band immediately follows. It became quite obvious to technicians that FM stations could be received by the average TV set. In fact, old-time TV receivers with continuous tuning through the FM band were also FM receivers, numbers, dial and all.

A few manufacturers built actual converters, resembling the UHF converter. Early models used tubes and more recent ones use transistors. Somewhat like the UHF converter, the FM converter has a mixer-oscillator stage that converts FM signals from the 88-108 MHz range down to 63 MHz or 69 MHz which is Channel 3 or 4's center frequency.

The outdoor antenna is detached from the TV terminals and attached to a pair of input terminals on the converter (Fig. 15). A short length of lead-in is run from the output terminals of the converter to the TV set. When the converter is off, the two terminals on the converter are shorted together by a function switch and the signal is passed as if the converter were not present. When the converter is on, the function switch attaches the antenna input to the mixer oscillator and turns on the power in the converter. The mixer receives the antenna input and the oscillator input. The two frequencies mix and the output is two frequencies simulating the video and audio of either Channel 3 or 4, whichever is blank in the area. (Even if neither are blank, the converter output overrides the TV signal.)

The video simulator signal is unmodulated and the audio carrier is modulated. The generated video and audio carriers are beat together and produce the 4.5 MHz required in the TV sound section. The FM signal then is converted into a TV-like transmission. It enters the TV tuner as a Channel 3 or 4 signal, becomes an IF of 44 MHz and is passed into the video section. A 4.5-MHz pickoff transformer injects it into the TV audio circuits.

The limitations are minor. The fact that the FM transmission has a bandsweep of plus or minus 75-kHz and the TV reproduces only plus or minus 25-kHz is not noticeable in the low-frequency TV speaker output. The fact that the TV has all those tubes burning just for the FM sound is forgotten, just like the instant-on feature of a TV, which also keeps tubes burning. The light on the TV screen can be extinguished with the

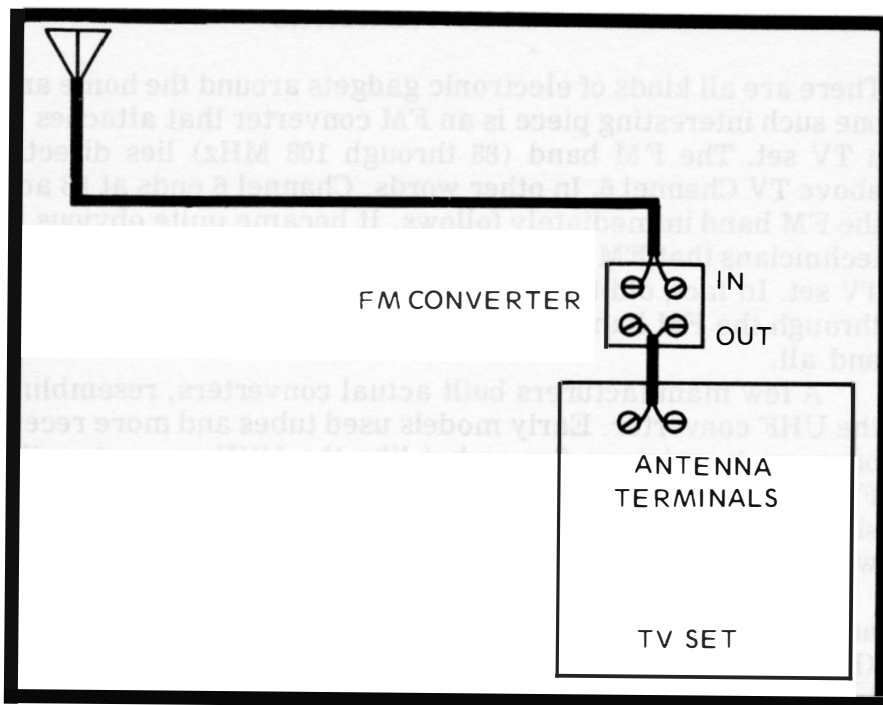

Fig. 15. An FM converter is attached to the TV antenna terminals exactly like a UHF converter.



RCA WR-508A Mini Chro-Bar generator designed for color signal production.

brightness control. This stops all CRT high-voltage current drain in black-and-white TVs. With color TV, however, there is still current drain in lots of regulator circuits. Nevertheless, these gadgets are found in homes and need testing on occasion. The tests are also applicable to similar type equipment. There are other forms of converters that operate with similar circuits. Only the frequencies are changed. Be sure to have service notes for correct frequencies.

FM converters are found with both inductive and capacitive tuning. Inductive tuning at these frequencies is accomplished with two conductive rods and a moving shorting bar. The rods are attached into the input and output circuits of the mixer oscillator. The RF input is tuned and the oscillator is made to track with the RF tuning. The tuning capacitor is quite small and it, too, is connected into the input and output of the mixer oscillator. There are two sections to the ganged capacitor and the sections track with each other.

The output of the converter (Fig. 16) is fed to the TV set through a TV type balun coil (balanced transformer). The twin-lead has one side attached to the bottom of the transformer and the other side to the top. The local oscillator can

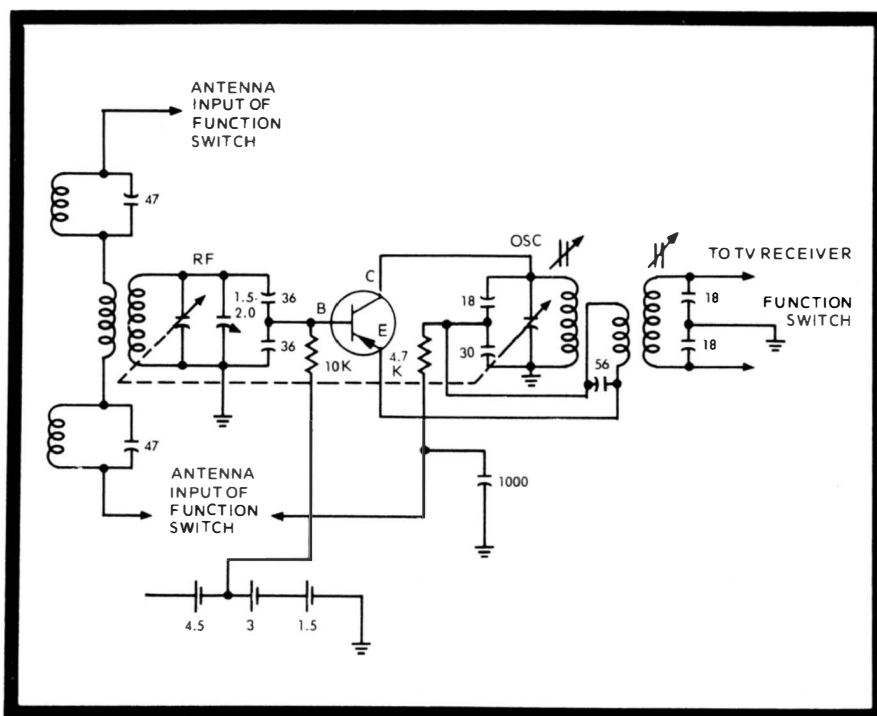

Fig. 16. An FM converter uses one transistor that does the job of tuned RF, oscillator and converter.

be tuned through a range of a little over 6 MHz. A frequency between 30.83 and 37.5 MHz is chosen for oscillator operation.

The RF is tuned to receive 88 to 108 MHz, the FM band. The two signals are mixed in the circuit and a number of frequencies are produced. Among them are the difference between the two frequencies and the second harmonic of the oscillator. If you consider the converter tuned to 108 MHz, the two resultant frequencies are:

Tuning	108.0
Oscillator	37.5
	<hr/>
Difference	70.5

Osc: 37.5 x 2 equals 75.0, the second harmonic.

Notice the two frequencies are 4.5 MHz apart. The 75.0 is a video simulation and unmodulated. The 70.5 is an audio carrier simulation and is modulated. The TV can easily use this mixture of frequencies and produce FM sound.

If you consider the converter tuned to 88 MHz, the two resultant frequencies are:

Tuning	88.00
Oscillator	30.83
	<hr/>
Difference	57.17

30.83 x 2 equals 61.76, second harmonic

Again notice the two frequencies are just about 4.5 MHz apart. The discrepancy of 0.09 is negligible.

61.76
57.17
<hr/>
4.59

#### 0.09 Discrepancy

The 4.5-MHz intercarrier sound frequency is needed to enter the TV sound system (Fig. 17).

### No. 15: FM CONVERTER OSCILLATOR ALIGNMENT

The oscillator is aligned for the center frequency of the FM band, 88-108 MHz, at 98 MHz. A signal generator is attached to

the input antenna terminals. A matching pad, using two 300-ohm resistors and two 1K resistors, matches the generator to the 300-ohm input. The two 300-ohm resistors are in parallel, the two 1Ks are in series, forming four sides of a block (Fig. 18).

The output of the converter is attached to a 44-MHz IF type TV, and the TV is tuned to the indicated channel, either three or four, according to what the converter calls for. The signal generator is set at 98 MHz, with an output of a 100 or so microvolts, with modulation not more than 50 percent. The converter's dial is set at exactly 98 MHz. The oscillator coil is tuned until the signal generator's modulation is heard from the TV.

### No. 16: ALIGNING THE FM CONVERTER RF INPUT

Once the oscillator is set for the FM center frequency of 98 MHz, the signal generator output is slowly reduced until some

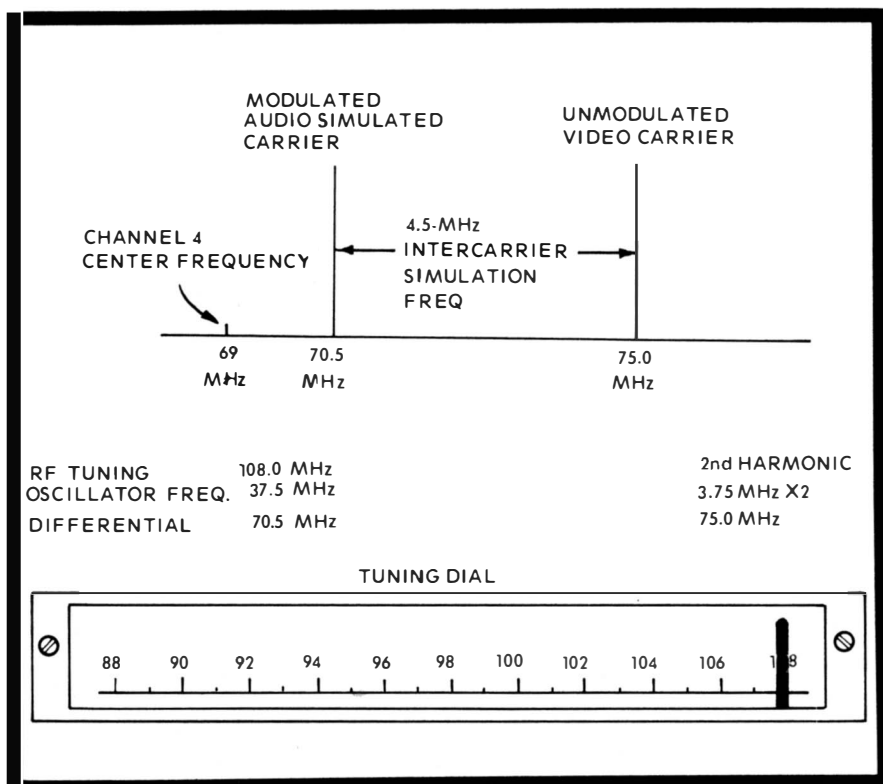

Fig. 17. An FM converter simulates a TV signal so the audio will be picked off by the 4.5-MHz intercarrier takeoff coil.

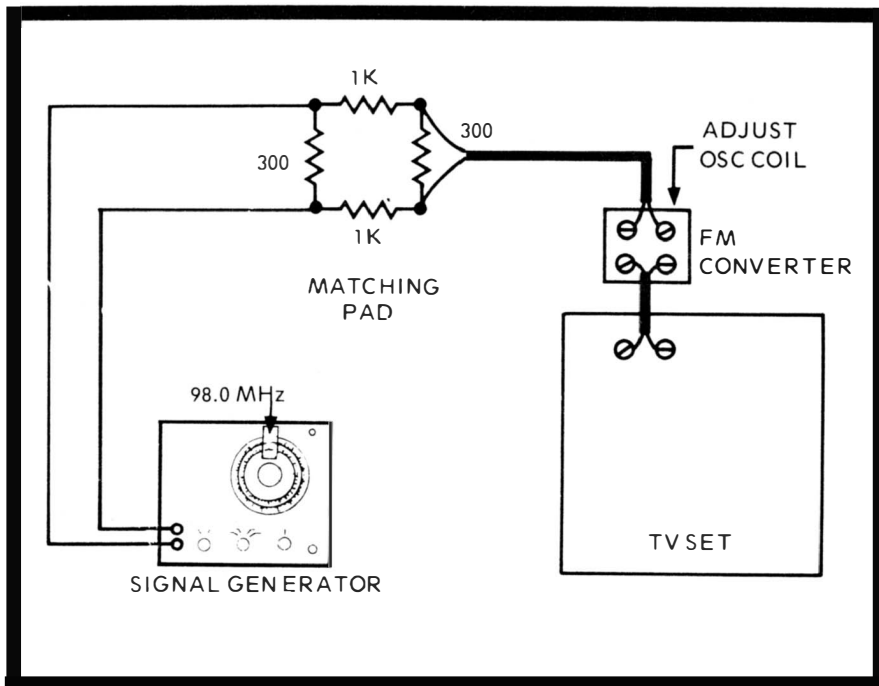

Fig. 18. An FM converter is easily aligned by attaching a signal generator and adjusting the oscillator coil.

static begins to mix with the generator signal. Set the generator at an output where the signal can be heard but is at its weakest. The RF coil trimmer capacitor (Fig. 16) is then tuned for peak audio from the TV. To obtain even greater accuracy, reduce the generator signal until it's barely heard and again peak the RF trimmer.

#### No. 17: ALIGNING THE FM CONVERTER IF OUTPUT

The intermediate frequency (IF) produced by the FM converter is, for example, Channel 3. Both a video carrier and an audio carrier are placed on the FM converter-generated Channel 3 carrier. In the TV tuner, the signals are heterodyned once more to produce the 40-MHz TV IF carrier.

The converter has to deliver as much usable signal as possible over the FM band. Therefore, adjust the IF output coil for maximum sound from the TV picture all up and down the FM band. Align the coil for peak performance at 88, 98 and 108 MHz by tuning the converter dial. Settle for the best compromise coil position.



## **No. 18: ROUTINE TESTING OF THE FM CONVERTER**

If the TV set is working fine on all channels, including 3 and 4, yet the converter is not producing any output, there is trouble in the converter. Common problems are due to poor connections, weak batteries and transistor failure. The rest of the components get practically no mechanical or electrical stress. Of course, any of them can short, open or leak, but in a well made converter it's unlikely. Since there is one stage, no further isolation of trouble is practical. Make routine DC voltage and resistance tests on all the components one by one.

Keep the unit away from constant heat, such as that from the TV set or a nearby radiator. The heat can cause thermal problems in the transistor, producing drift or failure.

## **No. 19: CHECKING STEREO SEPARATION—MULTIPLEX**

Whether you are an audiophile or not, it is difficult to determine by ear whether there is excellent, good, fair or poor stereo separation in your FM multiplex radio. When the radio is not producing the type of "solid" sound that it was, you can check to see if it is your ears or the instrument.

A typical good test unit is the Sencore Channelizer stereo generator. The test piece puts out a test stereo signal and a 19-kHz pilot signal. The signal is then fed into one channel, either right or left, of the stereo unit. The amount of that test signal that appears in the other channel—where it is not supposed to be—determines the quality of separation. The actual separation in a receiver is never 100 percent. There is always some mixing. Excellent separation exists when the ratio is 30 to 1, which is measured at 30 db. Good separation is 10:1 which is 20 db. Poor separation, though still listenable, can be as low as 3:1 or 10 db.

For the test, the RF cable from the Channelizer is attached to the FM antenna terminals. The radio is tuned to 100 MHz. A 1-kHz note will emanate from the radio. The left input is attached to the left speaker output and the right input is attached to the right speaker output. The balance and volume controls are set and the output meters in the unit are set at the REF line. Then, one channel is turned off and the 19-kHz signal turned on. The db separator is read directly on the respective meter (Fig. 19).

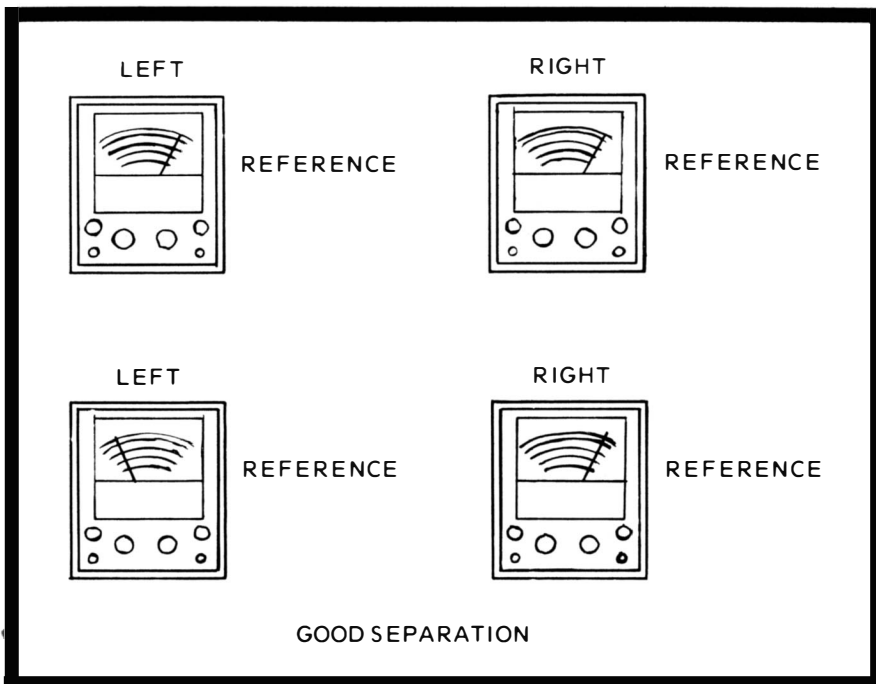

Fig. 19. Separation is indicated on the stereo test meters when the left and right dials read differently.

### No. 20: CHECKING CIRCUIT PHASE

Quite often the stereo effect is not achieved in an FM multiplex receiver and the cause is not readily apparent. One of the causes could be improper phase due to receiver misadjustment. At any rate, the phase should be checked to be sure it is not contributing to the poor stereo effects.

The Sencore Channelizer is an excellent test unit for checking speaker phase quickly. The RF signal is attached to the antenna terminals. The left speaker leads are attached to the left speaker output on the radio and the right speaker leads attached to the right speaker output of the radio. The connections should be double checked for accuracy.

The Channelizer and radio are turned on. The receiver volume and balance are adjusted until the two meters are both reading at full scale on the REF line. A normal signal is coming through, so both outputs are producing the exact signals. The left signal from the Channelizer is turned off. The left meter reading should show a drop. If it does, the internal phase of the radio is correct. Should the right meter show a drop and the left meter does nothing or very little, the receiver

has been somehow misadjusted in phase close to 180 degrees (Fig. 20).

Probably the multiplex section of the receiver is severely out of adjustment and a complete multiplex alignment is now necessary. First, double check the left and right speaker connections before doing the multiplex alignment.

### No. 21: MULTIPLEX CIRCUIT ALIGNMENT

Poor stereo separation, improper circuit phase, and simply the need to make sure the multiplex is correct to eliminate the stage as a source of trouble, are among the reasons for a multiplex alignment job. Sometimes the multiplex circuits develop subtle troubles like a shorted turn or two in a coil that can be pointed up only when an alignment will not take.

The Channelizer acts as a multiplex signal generator and the scope or peak-to-peak scale of the VTVM acts as the indicating device. The Channelizer is attached to the antenna input and the radio's speaker outputs are attached to the left and right meters, respectively. The left and right signal switches are turned off and the 19-kHz pilot signal set on at 10 percent.

The scope or peak-to-peak scale is attached across the secondary of the 38-kHz transformer (Fig. 21). Find the 38-kHz amplitude adjustment (not the 38-kHz phase adjustment) and set it for a peak reading in the scope or VTVM. Look for a 19-kHz amplitude adjustment, too. If there is one, adjust it for peak readings. Then, turn on the left signal switch. Find the 38-kHz phase adjustment this time. Adjust the phase for

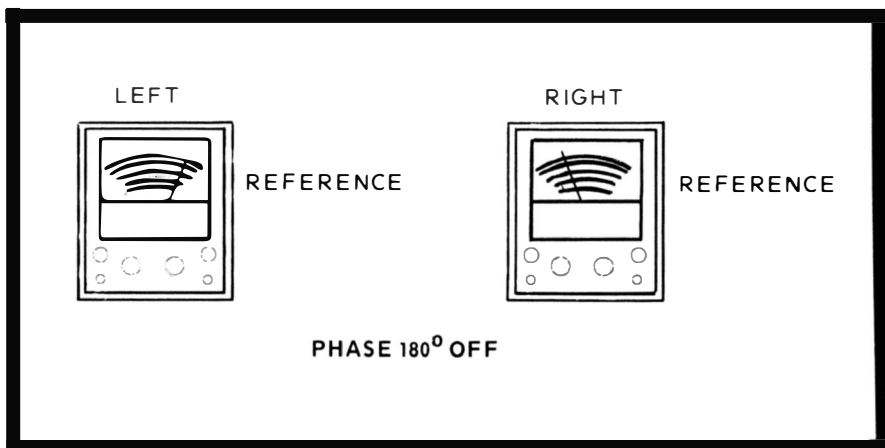

Fig. 20. The phase of the stereo signals can be tested with a pilot signal. Opposite readings mean opposite phase.

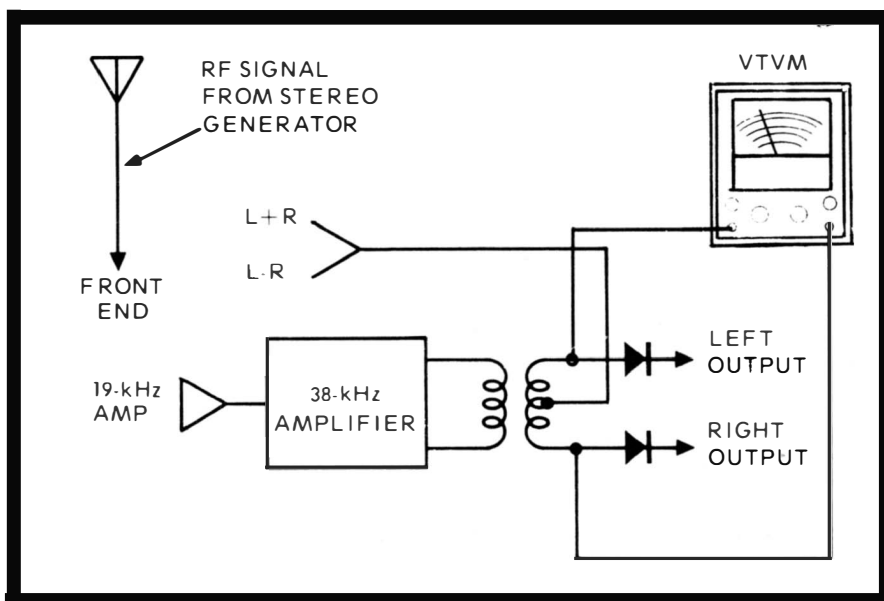

Fig. 21. Multiplex alignment requires a stereo generator input and a VTVM indicating device.

maximum reading on the left meter and a minimum reading on the right meter. This gives you separation which is part of the multiplex circuit alignment.

### No. 22: MULTIPLEX CIRCUIT "LOCK-IN" ABILITY

Confusion is prevalent concerning the separation capability of a stereo receiver. It is not unusual for good separation to exist on a strong local channel; however, weak channels show little or no separation. One of the reasons for this is misalignment of the 19-kHz or 38-kHz amplifiers (Fig. 22). If the alignment is way off, only the very strongest stereo stations will show some separation. If the circuits are slightly out of alignment, only the very weakest station will not have separation.

The stereo indicating light usually will provide the suspicion that stereo signals are not being separated, because a known stereo station won't light the bulb.

The Sencore Channelizer will provide a fast, accurate test by substituting output meters for speakers and producing a variable gain pilot carrier at 19 kHz. The RF cable and meters are attached to the stereo unit. The two receiver channels are balanced. Then the left signal switch is turned off and the pilot

set at 10 percent. The separation is noted on the left meter. With the pilot turned off, both meters will read at the same level. Then the pilot is returned to five percent. If separation is again attained, the 19-kHz and 38-kHz amplifiers are tuned properly and exonerated. If there is no separation, the amplifiers are detuned and require alignment.

### No. 23: MULTIPLEX CIRCUIT CHECK

When the multiplex feature of a radio stops working, but FM signals are still coming in loud and clear, all the signal-carrying circuits, except the individual audio L and R, become suspect. The multiplex could be lost in the RF-IF detector area if a defect occurred that reduced the bandpass of these circuits drastically. The multiplex signal contains frequencies up to 53 kHz. All those frequencies have to be passed. Ordinary FM needs only about 15 kHz. A defect could lower the bandpass, allowing the ordinary FM channel through but not the multiplex.

On the other hand, the RF-IF detector area could be fine, but a defect in the multiplex section could mix L and R together and ruin the multiplex effect. It is useful and time saving to isolate the trouble to one or the other of the circuits.

The Sencore Channelizer can accomplish this test by providing a signal that can be injected directly into the multiplex section, bypassing the RF-IF detector section. Thus, in a receiver with a separation problem on all channels, should separation suddenly occur, the multiplex circuits are cleared and the blame put on the RF-IF detector area. Should the separation still be nonexistent, the trouble is probably not in the RF-IF, but in the multiplex section.

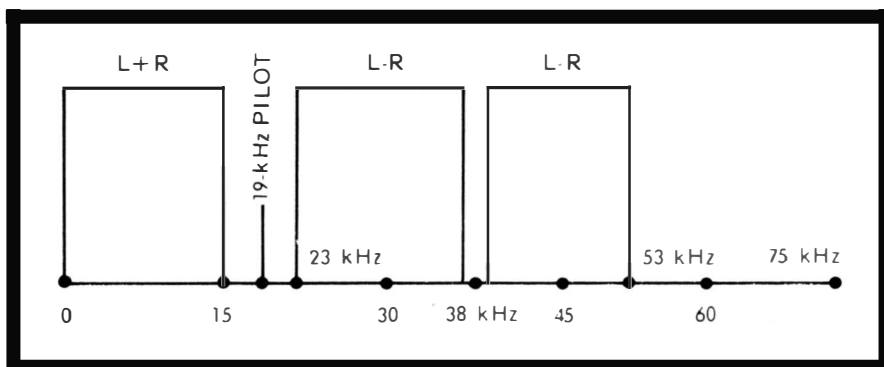

Fig. 22. The stereo multiplex transmission covers a large part of the available 75-kHz allowable bandwidth.

To effect the test, the speaker leads from the Channelizer are attached to the receiver speaker outputs. Care is taken to attach the wires to the correct terminal. The leads are taken from negative signal jack marked **Stereo Signal** and the positive jack also marked **Stereo Signal**. The negative lead is attached to the ground of the radio and the positive lead is attached to the input of the multiplex section. This could be the detector output.

The Channelizer's left and right signal switches are turned on, the radio is adjusted for medium volume. The radio balance controls are adjusted until both meters read on the REF line. The pilot is cranked up to 10 percent and the left signal switch is turned off. The left speaker meter indication will drop off, while the right will remain at the same setting on the REF line. The channel separation is noted on the left meter. It's a good idea to make a pencil notation of it.

The stereo signal leads are then removed from the receiver and the RF cable is attached to the input of the radio. The channel separation is again noted on the left meter. If the reading is the same as it was when the stereo signal was applied to the multiplex input, the multiplex section contains the trouble. If the separation is worse, the trouble is in the RF-IF-detector circuits. The multiplex section, if indicated, could be out of alignment, which is the next step. The RF-IF, if indicated, could have a reduced bandwidth. A sweep generator is used to check the bandwidth.

## Chapter 4

# Power Monitor Tests

### No. 24: LINE CURRENT—POWER MONITOR TESTS

The power monitor is a relatively simple piece of test equipment in comparison to the multimeter, oscilloscope, signal generator, etc. Yet, in the busy electrical appliance service shop, it is one of the most used units. It provides basic tests and can be used on every appliance that passes through the shop.

For instance, every appliance draws a certain amount of current. That current rating is specified in the service notes and on the appliance itself. Amounts vary from a few milliamps in a transistor radio up to 20 or 30 amperes in an air conditioner as it kicks on.

Current ratings should be correct, not too low or too high. When they are too low, some function of the appliance is not working. When they are too high, a leak or short is occurring, which signals danger.

The test on a power monitor, like the Sencore PM157, is easy. The monitor is plugged into an AC outlet. The range switch is set on the highest range, which in this case is 10 A. The function switch is set on **Amps-Watts**. The meter switch is set on **Line Cord**. The equipment being tested is plugged into the AC outlet on the face of the power monitor marked **AC Out**.

The appliance is then fed current through the power monitor. The amount of current it draws is shown on the amp scale. The amount is matched to its current specifications and a determination is made as to its correctness. That's all there is to it.

### No. 25: AC LINE POWER

Appliances are also rated in watts. For instance, an electric iron can be rated as 1200 watts, or a TV can be rated at 500 watts. Here, again, low wattage readings mean the appliance is not "firing up" properly, and higher than usual wattage readings mean an appliance is burning up too much power.

The wattage reading is an instant and accurate indication of the working quality of the appliance.

Most AC lines measure around 115 volts. As a result, power monitors, such as the Sencore PM157, are set for and are accurate at 115 volts AC RMS. If you are somehow checking an appliance on a drastically higher or lower line voltage, you have to convert the reading to the different line voltage.

With 115-volt AC RMS, the actual voltage test is identical to the AC line current test and, in fact, as you read the line current, all you have to do is look at the wattage scale and at the same time get the wattage.

When the line voltage is other than 115 volts, you must use a power-voltage conversion chart. Thus, you can get the power used by an appliance when the line voltage is not 115 volts. For instance, suppose you have a 100-watt light bulb being used with a line voltage of 127 volts. How many watts will be drawn?

Find 100 watts on the normal 115-volt line. Then follow the vertical blocks until you get near 127 volts. The wattage reads about 110 since more voltage is being applied.

#### **No. 26: AC LINE VOLTAGE MONITORING**

Most appliances are designed for the familiar 115-volt input. During service work, the question arises, is the appliance causing problems because 115 volts is not available? Or is the problem in the power supply section of the appliance.

The power monitor produces the answer quickly and accurately. The power monitor is plugged into the suspect AC line and the function switch placed on **Line Volts**. The line-volt scale is calibrated from 65 to 135 volts because a line voltage under 65 volts is almost impossible to find. The meter reads the voltage directly on the scale.

The line voltage might read 115 volts right on the nose. You might find such a reading on a cool morning in a trailer camp. That evening, though as the sun goes down and as the trailers became warm from dinner cooking, the lights and the TVs are turned on, the air conditioners started up, and so forth, the 115-volt line could drop drastically to as low as 90 volts. The TV picture shrinks, the electric iron does not get hot enough and so forth.

The power monitor, if it is plugged in and a reading taken every hour or so, will reveal the pattern the AC line is following. It tells the servicer that the appliances are probably OK, while the trouble is on the AC line. It better be corrected or the wires can become too hot and possibly cause a fire.



## No. 27: FUSE DESIGN TEST

The field serviceman often encounters an open fuse, circuitbreaker or fusible resistor. The question is, has the fusible unit opened due to its own defect or a short circuit in the electrical appliance? The usual reply is a replacement of the fuse or resetting of the circuitbreaker. Then the unit is turned on again. If the fuse blows quickly, there is a short in the unit. When the fuse does not blow, it is assumed that there is no further trouble.

Repeated fuse burn out is costly. Just because the new fuse doesn't burn up, it does not mean there is no short. It could be an intermittent tube that shorts as soon as the technician drives away.

It would be much better to measure the amount of current the appliance is drawing across the fusible unit. If a current reading could be made, the following wiser service moves could be conducted. Suppose a stereo radio is found with a blown 5-amp fuse. A reading is taken and the unit is found to be passing about 8 amperes through the fuse connections. Immediately, the fact is known that a bad leak has developed and the cause of the leak should be located before any further tests or fuse replacements are made.

Another case in point could be a color TV that is popping its circuitbreaker. The breaker is reset and the TV comes on for a minute or two, then trips the breaker again. A current reading taken across the open breaker may reveal a current of only 5 amperes. Yet it is a 7 ampere rated circuitbreaker. Obviously, the breaker itself is at fault. It cannot carry its rated current. A new breaker must be installed for the repair.

A third common trouble is the fusible resistor. Assume a burned-out resistor is found in an appliance. Instead of trying a new resistor, the current flow through the resistor is checked across the terminals in the appliance. It is a small resistor with a 4-watt rating. The appliance is turned on and the current is shown in the low milliamp range. That means the resistor died of old age and you can be safe putting in a new one.

If, on the other hand, the current was considerable then the resistor had been burned out. The reason for the high current drain would have to be found before a new resistor was installed, or, the replacement would go right up in smoke.

In a power monitor like the Sencore PM157, fuses are tested by performing the AC line current test, except that the meter switch is set at **Test Leads** instead of **Line Cord**. This simply switches the AC output connection to a more convenient position for this test.

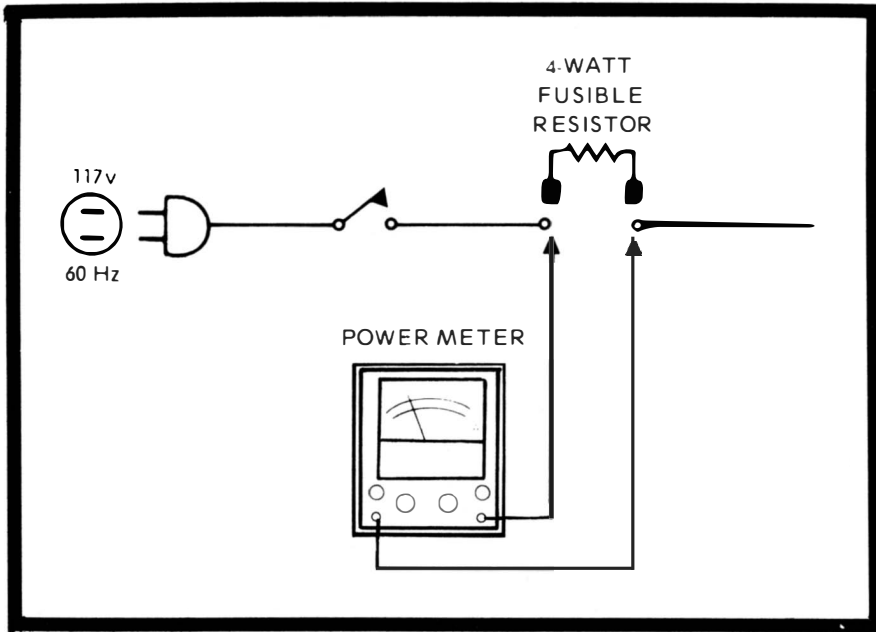

Fig. 23. A good power meter can test the exact current that an electronic unit draws to verify fuse capability.

The test leads are applied across the open fuse and the power monitor takes the place of the fusing unit (Fig. 23). The appliance could still be attached to the AC output for its current supply, but the meter will not read unless the test leads are used. The meter is set on the 10A scale. This should be sufficient for most fuse tests.

## Chapter 5

# TV Tests

### No. 28: IF AGC TV TESTS

The symptom of AGC trouble appears on the TV screen as a loss of or distortion of video only on strong local channels. The weak snowy stations are unaffected or are sometimes better. Also, with AGC trouble, the picture could be missing, have too much contrast or weave. The key to the AGC diagnosis is that the symptom occurs primarily on strong channels and to a lesser extent or not at all on the weak channels.

Once AGC is suspected as the trouble, the fact must be proved before component-by-component testing of the AGC circuit is begun, because a defect in the IF circuit or video detector could also be causing the same symptom. If the AGC symptom is not being caused by the AGC circuit itself, that fact should be ascertained at the beginning of the repair.

The best way to be sure is to substitute an external bias for the AGC circuit and observe what happens. A bias box acts exactly like the AGC circuit. It provides a variable plus or minus DC voltage. An AGC circuit simply provides a plus or minus DC voltage to turn the RF and IF off and on to various degrees according to the incoming signal strength.

To test the IF AGC, attach the bias box to the first IF input on the AGC circuit side of any isolation resistor in the circuit (Fig. 24). Then, turn on the TV and try to get rid of the AGC symptom by adjusting the bias box voltage. If the symptoms disappear, the AGC circuit contains the trouble. If the AGC symptoms persist, the AGC circuit itself is exonerated.

### No. 29: RF AGC TEST

When a TV picture develops snow on strong channels and the weak channels still come in as usual, the RF amplifier is indicated as defective. However, the RF amplifier itself might not be defective; the AGC input to the RF amplifier might be at fault.

The AGC circuit has one DC output which varies slightly in accordance to the amount of signal that is passing through the

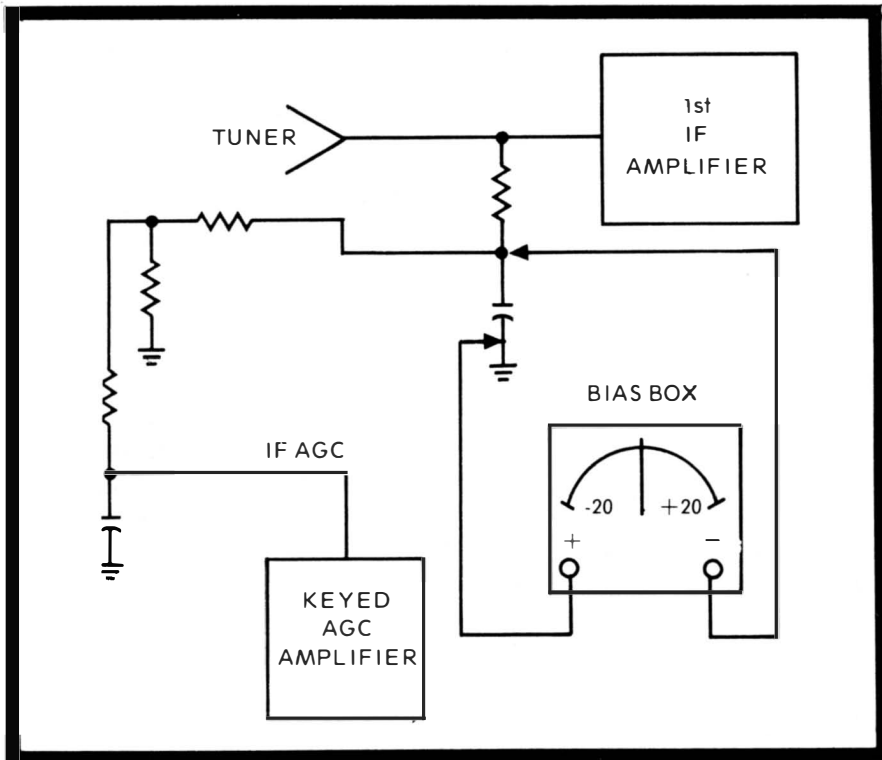

Fig. 24. The bias box can be used as a substitute for the AGC voltage, confirming or denying suspected trouble.

video detector. For tube circuits the DC must be a negative voltage if it is applied to the control grids of the tubes. On rare occasions when the AGC is applied to a cathode of a tube, the AGC must be positive DC in order to change the cathode voltage as a means of varying the tube gain in order to compensate for variations in the video and provide a constant amplitude output.

In NPN transistor circuits, since the NPN electron flow is from emitter to base and collector, just as the electrons is in a tube flow from cathode to plate, the AGC applied to the base must be negative. If applied to the emitter it must be positive.

In PNP transistor circuits, since the electron flow is opposite to that in an NPN and tubes, or from the collector to base and emitter, the base injected AGC must be positive. If applied to the emitter, it must be negative.

All this discussion notwithstanding, if the RF AGC connection is disconnected and the snow ceases, the RF AGC base line contains the trouble. If the snow persists, the AGC input is good and the trouble is in the RF amplifier.

## No. 30: HORIZONTAL OUTPUT CURRENT

In a black-and-white and especially in a color TV, high-voltage requirements are strict. There might be no apparent symptoms except that the horizontal output transformer (flyback) or horizontal output tube repeatedly burn out. Don't just keep changing the expensive parts. Find out why the part keeps failing. It is rarely due to poor design on the part of the manufacturer.

It is a good idea to check the amount of current passing through the horizontal output circuit. If there is a little too much current, the parts will overheat and eventually fail prematurely. When the current is extremely high, the part will burn up within minutes.

The best place to make a test is in the cathode of the horizontal output (Fig. 25). In fact, many color TVs are equipped with removable links to permit the insertion of a milliammeter into the circuit without unsoldering. The meter should read anywhere from 150 milliamps to 220 milliamps according to the actual circuit. The service notes should specify the exact amount of current.

Too much current can be caused by many conditions. A shorted screen grid resistor or capacitor, a leaky component in the flyback circuit, or any number of other things. The most common cause in a color TV is a de-tuned flyback circuit. The Q is lowered and added drain put on the horizontal output. The circuit can be retuned by "tuning" the efficiency coil until the current is reduced to the amount specified in the service notes.

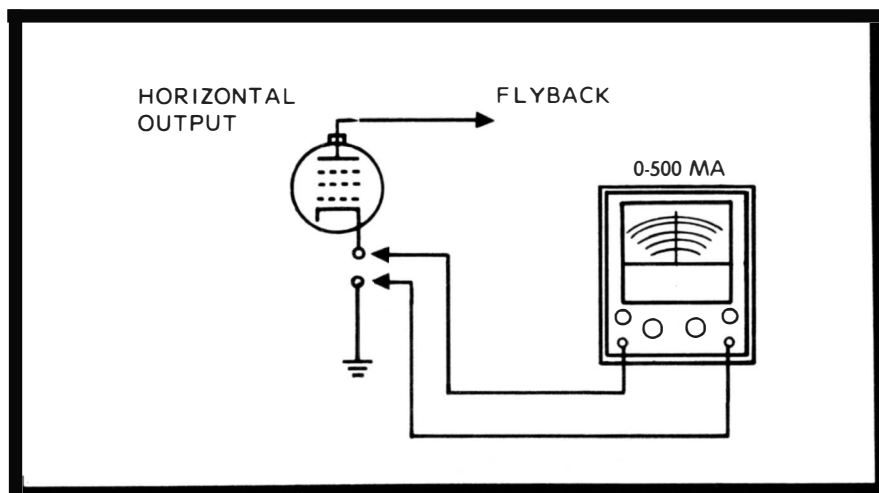

Fig. 25. The color TV horizontal output cathode current is a critical test with a 0-500 milliammeter.

Minimum current is sometimes the correct setting, but not always.

### **No. 31: COLOR TV GRAY-SCALE TEST**

With the color intensity control turned off, a color TV picture ideally should have no color in it. The viewer should not be able to tell that the TV is a color set by analyzing the picture. The whites should be white. The blacks should be black and the grays true. If there is a tint to the picture at all, in the highlights (white) or the lowlights (gray and black), the gray scale is defective. Many older TVs are not capable of producing a perfect black-and-white picture; however, recent TVs all are. When a TV that is capable of a good black-and-white picture does not have one, the first step is a gray-scale alignment test.

The color TV picture, even monochrome one, is composed of a mixture of red, blue and green light. The correct mixture produces a perfect black and white. The three electron guns (red, green and blue) in the CRT are adjusted with the CRT bias, the three screen controls are the three drive (control grid) controls (Fig. 26).

The service switch kills vertical sweep, producing a horizontal line. The three drive controls are turned all the way up and the three screen controls are turned all the way down. Then the screens are turned back up until a small amount of each color light is mixed in the correct proportions to produce a white line. Then, the service switch is reactivated, producing full sweep again.

If there are any tints in the highlights, the drives are adjusted to remove it. If any of the screens won't produce a color, the CRT bias is turned up until it does. With practice, the test is performed in minutes.

### **No. 32: COLOR TV PURITY**

When the colors in a TV picture are incorrect in spots and when a black-and-white picture has splotches of tinting, it is an indication that the purity adjustment is off. This is different than the gray-scale problem with tinting over the entire display. In fact, you can set up the gray scale and get a good monochrome picture except for these splotches.

The gray scale is dependent on the purity, though. The purity is perfect when each electron beam is landing on its correct color phosphor. If the beam is lighting up another

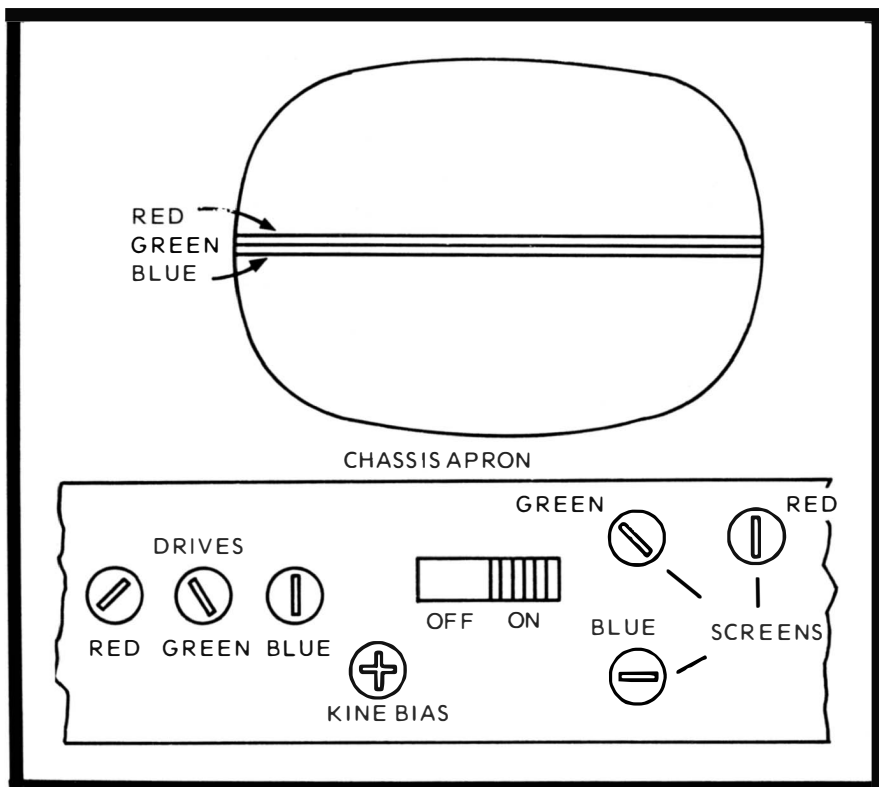

Fig. 26. Color TV gray-scale setup is conducted with simultaneous use of eight chassis apron controls.

phosphor, the purity needs adjusting. A magnifying glass or small telescope enables you to see a closeup of the phosphor dots on a color TV screen. If you look closely, you can see that the beams are landing incorrectly.

The reasons for impurity are three (Fig. 27): One, the CRT or its holder has become magnetized, thus pushing the beams off course. Two, the purity ring on the CRT neck could be misadjusted, pushing the beams near screen center off course. Three, the deflection yoke could be too far forward or too far back on the neck of the tube, causing incorrect crossover points for the optical-like beam, thus changing the landing position of the beams, especially around the perimeter of the CRT.

The first step in the cure is to get a red field by turning off the green and blue screens, then degauss the CRT. Next, adjust the purity tabs for screen center and the deflection yoke for the CRT perimeter. By performing the job two or three times a near perfect red field is produced. Then the gray scale must be reset.

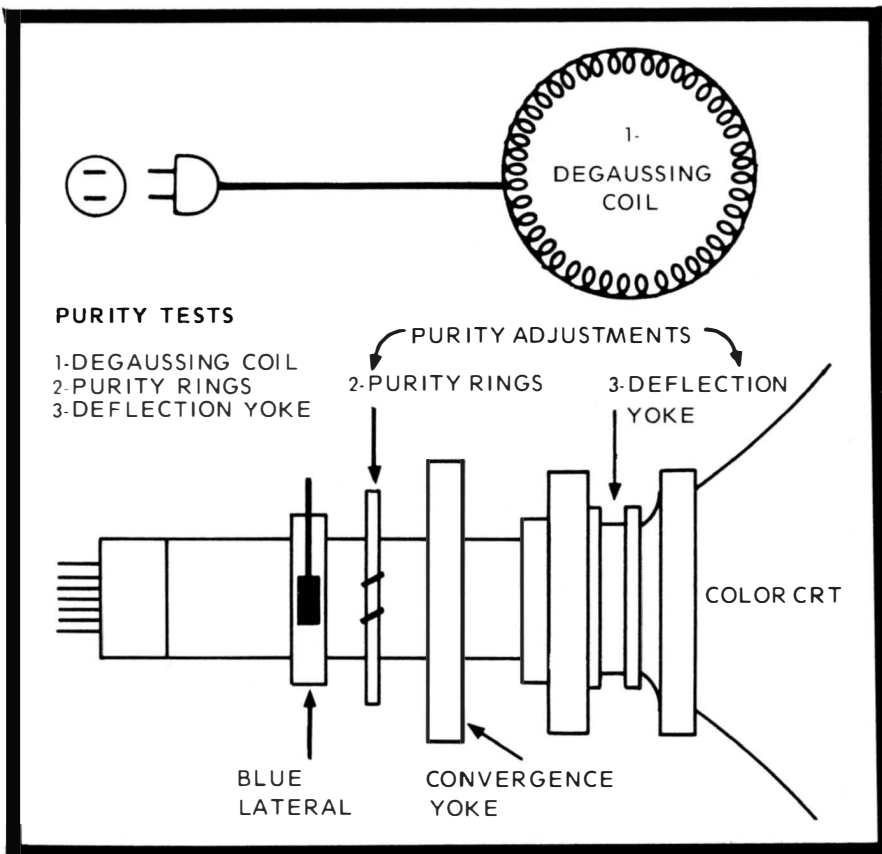

Fig. 27. The purity of a color TV picture is adjusted with a degaussing coil, purity rings and yoke.

### No. 33: COLOR TV DOT CONVERGENCE

The major problem with a 3-gun color TV picture tube is getting the three separate pictures, red, green and blue, in perfect registry. The three pictures must be reproduced one on top of each other. At spots on the screen where registry does not take place, colors will bleed and distort the picture.

Bleeding, while noticeable in a color display, is even more noticeable in a black-and-white picture. Therefore, it is a good idea to analyze a black-and-white picture for bleeding and perform the necessary adjustments while observing the black-and-white picture.

It is possible to adjust the faults in registry or convergence, as its called, with an off-the-air program, and it is even easier if you can find one channel that is transmitting a stationary test pattern, weather program or stock market



numbers. The best way to converge, however, is with a dot-bar generator. The generator places a pattern on the screen that is steady and won't disappear all of a sudden like a test pattern.

The TV screen is divided into five distinct sections for convergence adjustments. Each has its own controls. The sections are center, top, bottom, left side and right side. We discuss the center adjustments here and the other four adjustments in the next test.

The center adjustments are best made with a dot pattern on the screen. A crosshatch pattern could be used, but the dots are the ideal. There are four adjustments especially designed to move the color dots around in the center of the screen. They are called the statics—red, green and blue and the blue lateral. These four adjustments are found on practically every 3-gun color TV.

The color dot-bar generator is attached to the TV antenna terminals, set at one of the low VHF channels and all the equipment turned on. Dots are sent into the TV. The entire TV screen will display the dots, but for the static adjustments, only a small section in the center of the display is watched.

The rest is easy. Set up a mirror in front of the TV set and begin the adjustments. The idea is merge the three dots, red, green and blue, together until they produce a single white dot.

The red static adjustment, usually found at the eight o'clock position on the convergence yoke, causes the red dots to move diagonally across the screen from left to upper right (Fig. 28). The green static adjustment, usually at the four



B & K Model 1246 digital IC color generator used for convergence adjustment.

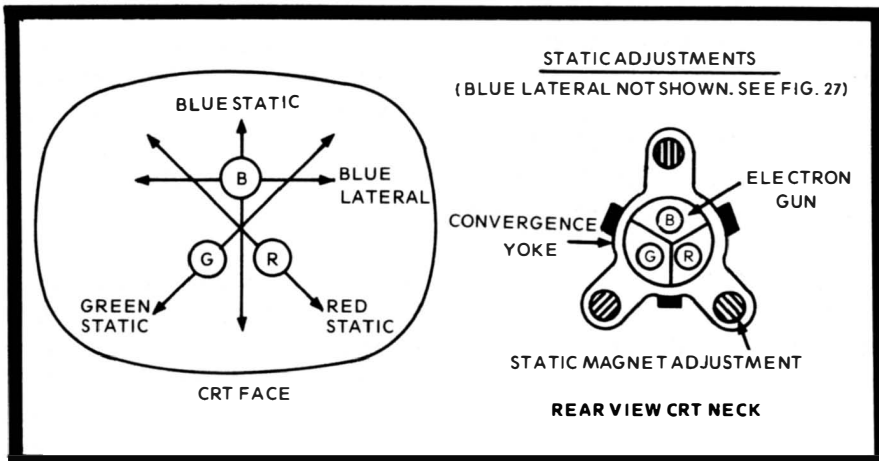

Fig. 28. The blue lateral, red, green and blue statics are all adjusted to achieve convergence at screen center.

o'clock position (green and red could be reversed), causes the green dots to move diagonally across the screen from bottom right to upper left. When the red and green dots merge, they make yellow dots. The blue static adjustment, usually at the 12 o'clock position, causes the blue dots to move up and down. The blue static is adjusted until the blue dots merge with the yellow or are alongside the yellow.

The blue lateral adjustment, usually set back on the CRT neck, causes the blue dots to move side to side. It is adjusted until the blue dot merges exactly with the yellow dot. This produces the white dots and convergence is accomplished at screen center.

#### No. 34: COLOR TV CROSSHATCH CONVERGENCE

Once the center of the color display is converged, there are four other sections of the screen that should also be put into perfect registry, the top, bottom, left side and right side. The 3-gun color CRT is usually equipped with a convergence board with 12 adjustments to perform this task. There are three adjustments on the board for each of the four sections. The top, bottom and left-side adjustments are usually potentiometers. The right-side adjustments are tunable coils. The coils must be adjusted with a hex head neutral stick.

From set to set, the twelve adjustments appear on the board in many different arrangements. However, they are set up primarily to merge the crosshatch bars in the respective sections. Dots, TV channel test patterns and even a live pic-

ture are suitable for the adjustment procedure, but ideally a crosshatch pattern is best. You should see red, green and blue crosshatch patterns on the screen. When they are merged, they produce a white crosshatch, and when a white crosshatch appears all over the screen, all three beams are in perfect registry.

For practical purposes, quite often perfect registry is impossible, due to the imperfections in the TV or CRT. At these times the best compromise picture is usually satisfactory. If the crosshatch can be made to appear merged at six feet, without noticeable bleeding, the viewer will usually be satisfied. If convergence cannot be obtained, a defect in the receiver's high-voltage section, sweep section or CRT is indicated.

The same hookup is used as was described in the color dot section, except the generator is switched to produce a crosshatch output. Once the crosshatch is displayed and the center has been converged, the top, bottom, left side and right side are analyzed (Fig. 29). It must be remembered that if after some of these adjustments, called dynamic, are made, and the center should go out of adjustment, it can be reconverged and then the dynamic adjustments continued.

There are adjustments for the following parts of the crosshatch. One, the red-green horizontal bars. Two, the red-green vertical bars. Three, the blue horizontal bars. There is no adjustment for the blue vertical bars. They are the reference by which the other bars are adjusted. If you find the blue vertical bars are out of adjustment, you must reset the blue static, the blue lateral and then try to merge the red-green vertical with the blue vertical. You can't adjust the blue vertical dynamically.

There are three adjustments for each section of the screen. Consider each section of the screen independent of the other. However, there is considerable interaction between the top and bottom adjustment, and also between the left-side and right-side adjustments. It is good technique to use two hands. For instance, when you are adjusting red-green vertical at the top, keep the other hand on red-green vertical at the bottom. If the top adjustment moves the bottom a bit, you can immediately adjust it back into place.

Or if you are adjusting red-green horizontal on the left side, keep a neutral stick in the red-green horizontal on the right side. If some unwanted bar movement occurs in the right side as you adjust the left, you can touch up the right-side coil as it goes out. If you are turning one of the right-side coils and it suddenly stops having any effect, chances are good you have

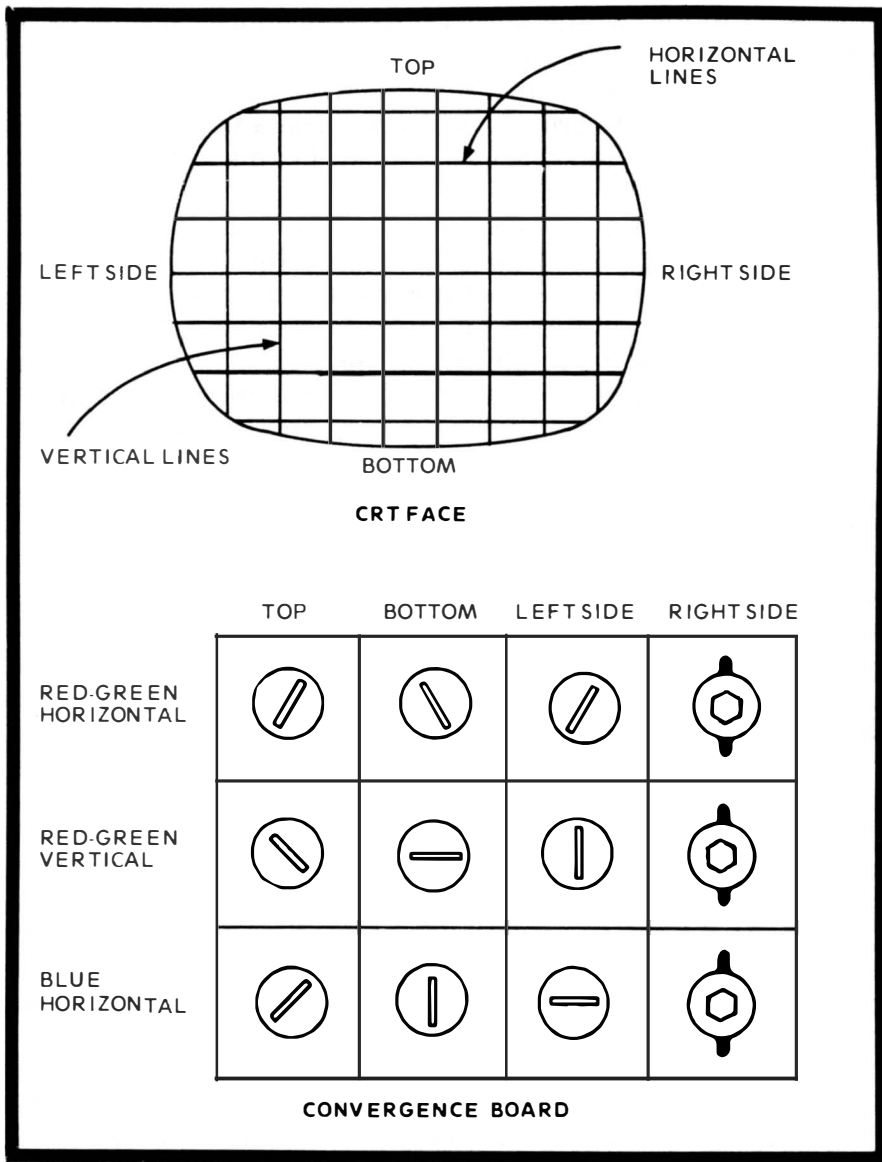

Fig. 29. The twelve adjustments on the convergence board and the crosshatch from a color generator are used in convergence adjustments.

rotated the coil past the resonant point. Further adjustment is useless. Rotate the coil back to a location where it has an effect again. It is useless anyplace else. The actual alignment from beginning to end is routine and easy as long as you are aware of what the move you are making is accomplishing.

When you analyze and see more bleeding out of the left-side blue horizontal bar, it can be touched up by going to the

blue horizontal left side pot and adjusting it, keeping a neutral stick in the right side blue horizontal coil. If you make any other move, you are not only wasting your time but could throw off the precise adjustments.

From beginning to end, the routine adjustments follow this pattern:

1. Adjust the top and bottom red-green vertical for convergence on the reference blue vertical bars.
2. Adjust the left-side and right-side red-green vertical for convergence on the reference blue vertical bars.
3. Adjust the top and bottom red-green horizontal for convergence on the blue horizontal bars.
4. Adjust the left-side and right-side red-green horizontal for convergence on the blue horizontal bars.
5. Adjust the top and bottom blue horizontal for convergence on the red-green horizontal bars.
6. Adjust the left-side and right-side blue horizontal for convergence on the red-green horizontal bars.

Notice there are only six steps for the 12 adjustments on the board. That's because good technique dictates using two adjustments at a time in the full convergence procedure. If you are touching up one section, it need be that you have to adjust only one at a time. The steps can be taken in any order and it will be rare that the entire alignment will be completed with one pass. Usually, you'll have to adjust and adjust, going back and forth between the four statics and the twelve dynamics. It is also usual that you will have to redo the gray-scale and purity adjustments as you perform this alignment.

Touchups only are usually needed when the TV has been operating for awhile and bleeding begins due to aging of components. The full alignment usually is needed only during times when the TV has been disassembled because a color CRT, deflection yoke or convergence yoke became defective. When there is an actual component defect in the convergence circuitry, registry is not impossible. If you find such a case, abandon your alignment procedure until you are able to get the convergence circuit difficulty out of the way. Otherwise, you are wasting time.

### **No. 35: COLOR TV AFPC ALIGNMENT**

The colors in a TV picture are locked into place by means of the color sync section, commonly called the AFPC. The heart

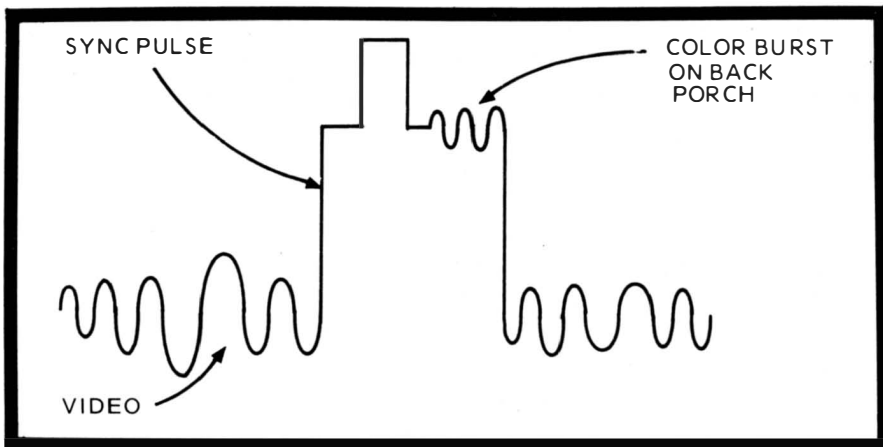

Fig. 30. The composite TV signal has about eight "rings" of color burst on the horizontal sync "back porch."

of the color sync section is the 3.58-MHz color oscillator. The 3.58-MHz color subcarrier is suppressed at the transmitter and must be reconstructed in the receiver before the color can be reproduced in the display.

The 3.58-MHz oscillator is the reconstruction mechanism. The oscillator, however, cannot simply run free at 3.58-MHz. It must run exactly at 3.58 and exactly in phase with the incoming signal. The information to lock in the oscillator is transmitted to the receiver on the "back porch" of the composite TV signal (Fig. 30). The color sync pulse takes the form of a sine wave with eight ringing waves. The sine wave, of course, is of the correct phase and it's called the "color burst."

The burst is extracted from the back porch, amplified in a burst amplifier and then fed as sync into the oscillator circuit. The oscillator output is then sent off to the demodulators.

When the oscillator is off frequency, an incorrect signal is sent to the demodulators. This causes incorrect colors on the screen or causes the colors to cascade through the picture in a disturbing fashion. When this trouble occurs, the best approach is to perform the AFPC alignment. If the oscillator is simply running off frequency, alignment will quickly restore the correct synchronization. If there is a defect in the AFPC network, the alignment will localize the defect to a particular circuit.

There is more to the color sync section than just the oscillator and burst amplifier. In order to lock in the oscillator, a sampling of the oscillator output is injected into one end of a phase detector. The output of the burst amplifier is injected into the other end of the phase detector, where a DC output

voltage is obtained from a center tap in the phase detector circuit. This output is fed to a reactance circuit. The varying DC changes the bias of the reactance circuit and thus its output (Fig. 31).

The reactance circuit, which acts as a varying capacitance or inductance, is connected across the oscillator and is an integral part of the oscillator's frequency-controlling tank. The output of the reactance circuit causes the oscillator to vary slightly in frequency and phase. As the oscillator tends to vary from the prescribed frequency, the sample is compared to the incoming burst and the DC control voltage brings it back into step with the burst.

You can do the alignment with an off-the-air TV program, but better control over the procedure is obtained if a color-bar generator is used. The color-bar generator is attached to the antenna terminals and the tuner set to a low VHF channel. The color bars should appear in a specific order on the screen when the set is operating correctly. The phase of the oscillator is indicated by the color of the bars and the frequency of the oscillator by the stability of the bars. A discrepancy of only 2 Hz will cause the bars to drift. There are lots of color receivers which do not use reactance control. If you are aligning one of them, simply skip the reactance part of the alignment.

The alignment is performed with a good multimeter and several jumper leads (Fig. 32). Tune in the color picture for best reception. Try to eliminate any sound bars that might be present. Turn the color intensity control all the way up for the greatest color intensity. Open up the color killer as far as it goes to be sure that the most color is present. Set the color tint control to the center of its range. That will be its correct setting if the alignment goes as planned.

1. Take a couple of readings in the phase detector. Take a reading at one of the diodes on the burst transformer side. You will get either a plus or minus reading. It doesn't matter which. It should be anywhere between 20 and 40 volts. Attach the VTVM there and remember the reading.

Attach a jumper cord from the burst amplifier input to ground. Adjust the 3.58-MHz oscillator transformer for maximum VTVM voltage. If you can't get any voltage now with the jumper in place, there is a problem in the oscillator or in coupling to the detector. If you get a good voltage, the oscillator itself is eliminated as the problem and you now have the oscillator transformer correctly aligned.

2. Remove the short from the burst amplifier. As you take the short out, the voltmeter needle should jump higher. That's the burst entering the phase detector and mixing with the

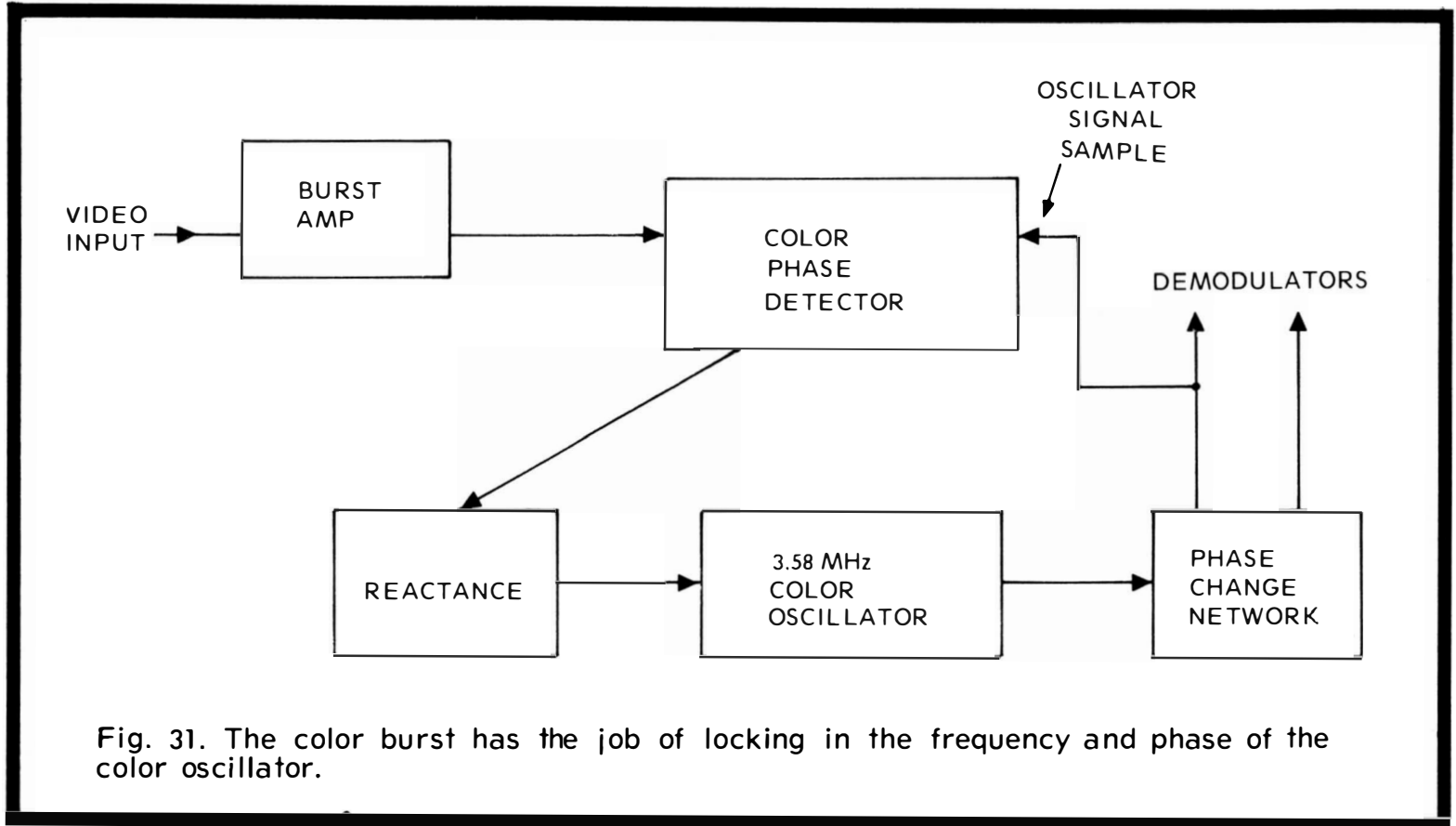

Fig. 31. The color burst has the job of locking in the frequency and phase of the color oscillator.



oscillator voltage. If the voltage does not increase, the burst amplifier is causing the trouble. When the voltage does rise, the burst amplifier is cleared. While you are there, adjust the burst transformer for maximum voltage, which correctly aligns the transformer.

3. Take a jumper cord and ground the DC input to the reactance circuit. There is usually a special test point just for this purpose. In fact, you do this step only when you want to just touch up the AFPC. When the jumper is installed, the

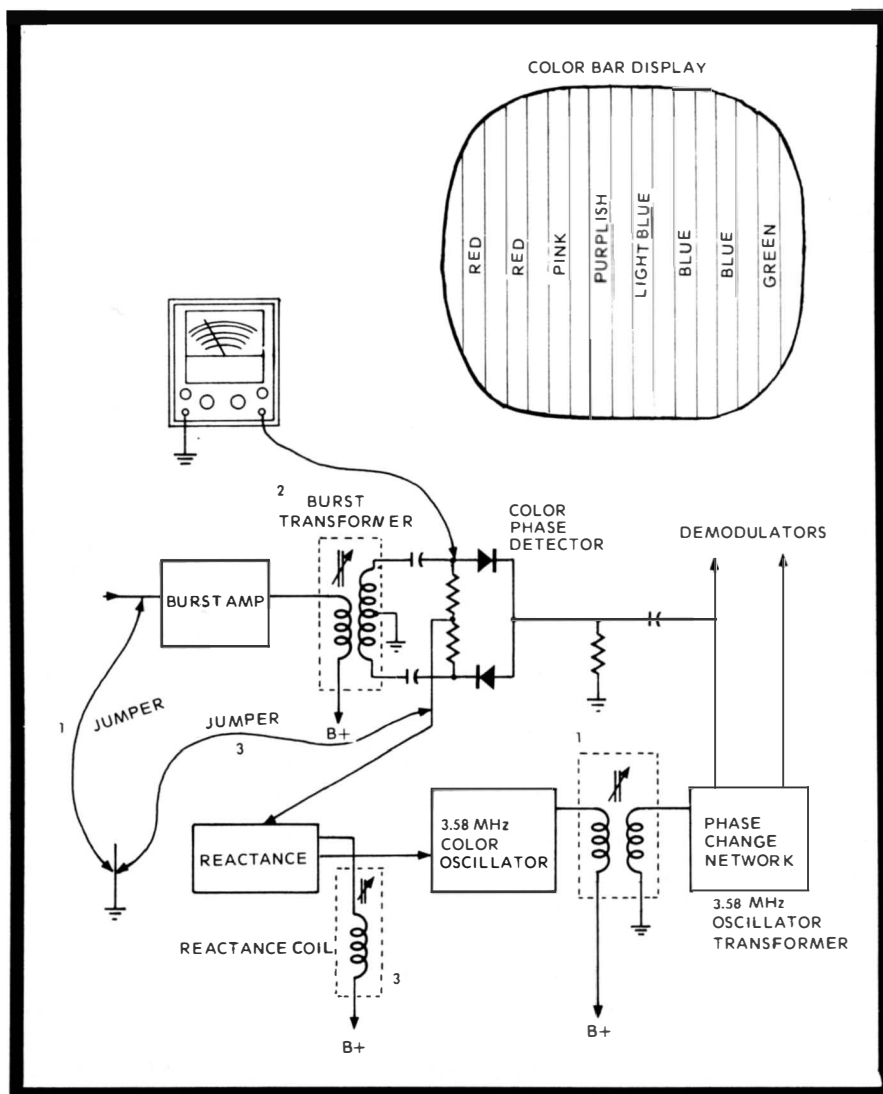

Fig. 32. The AFPC alignment is easily done with a color-bar generator input, jumpers and a VTVM indicator connected as shown.

oscillator runs free without sync. If the colors really go wild, it means the oscillator transformer was badly mistuned and was unstable for that reason.

Adjust the reactance circuit output coil until the colors just float by. The oscillator is then running free but right on 3.58 MHz. If you can't get the colors to float by or hold still, the frequency-controlling components in the oscillator have a defect. This includes the entire reactance circuit and the 3.58-MHz crystal.

4. Once float-by is attained, remove the reactance input jumper. The colors should snap into place. If they do, the AFPC alignment is completed. If the colors do not lock, but are floating, the reactance circuit has a defect. Should the colors not only continue to drift but begin a fast whirl, there is a defect in the phase detector. This could be due to a bad diode.

The AFPC alignment can be performed in minutes once the technician with practice. It is a vital procedure in color TV servicing. Without it, the entire AFPC circuit becomes a maze of confusion and cannot be serviced intelligently. Slight differences in procedure vary from TV to TV.

#### **No. 36: VECTORSCOPE HOOKUP**

Much confusion reigns concerning the vectorscope troubleshooting technique. It is thought of as an instant cure all for the color circuits; therefore, special vectorscope instruments are marketed and sold. While vectorscope equipment is useful and the techniques valuable, the basic equipment is already on the service bench if you have a scope and color-bar generator. The technique does provide some valuable service information on some color TVs, but not all.

A vectorscope unit is nothing more than a scope with isolated, balanced vertical and horizontal inputs. You can use your scope. Take two high-impedance probes and attach one each to the vertical and horizontal inputs (Fig. 33). Switch the horizontal sweep to external. Next, inject your color-bar generator's output into the receiver antenna terminals. The color TV has to have a difference amplifier output of R-Y, B-Y and G-Y. You will not get an accurate vectorgram from a TV that has pure R, B and G color outputs.

Attach the vertical probe across the R-Y output and the horizontal probe across the B-Y output. The color-bar signal will then provide a stationary pattern showing the R-Y and B-Y outputs (Fig. 34). The R-Y sweeps the vertical component and the B-Y sweeps the horizontal component.

In a vectorscope, you will immediately have the desired "daisy" displayed. In your ordinary scope a display will ap-

pear that might resemble a daisy but could be distorted. You must carefully adjust the vertical and horizontal sweep amplitudes in order to get a good looking daisy.

Once you get a daisy so what? Well, it provides an accurate picture of the R-Y and B-Y signals. Analysis of the vectorgram tells you whether or not the bandpass amplifier is tuned properly, whether or not there is adequate color amplification, if the color frequencies are correct, as well as the color phase relationship, etc. The height of the petals gives an indication of the color amplitude. Adjust the bandpass amplifier transformer for best height and roundness of the petals. The roundness indicates the bandpass response. Petal roundness should be normal, not too fat or too thin.

The positioning of the petals provides an indication of correct frequency and phase. If the petals are rotating, there is color sync trouble. If the petals are holding but the third (R-Y) is not pointing 12 o'clock, the phase is off. Either

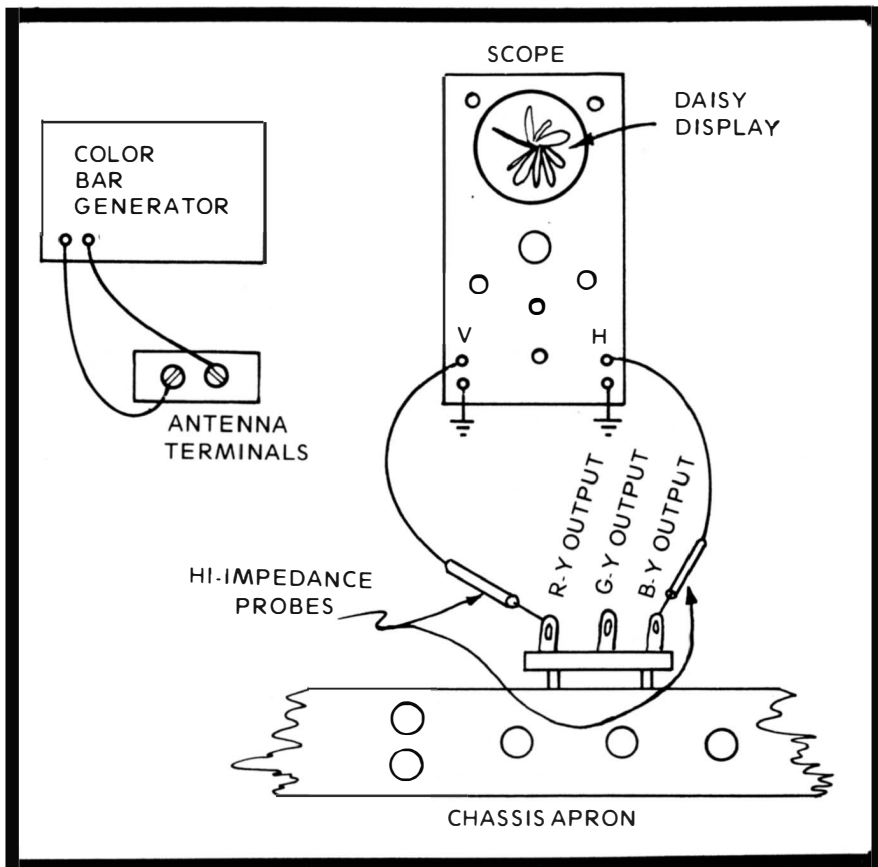

Fig. 33. A vectorscope display can be achieved with an ordinary scope, two probes and a color-bar generator.

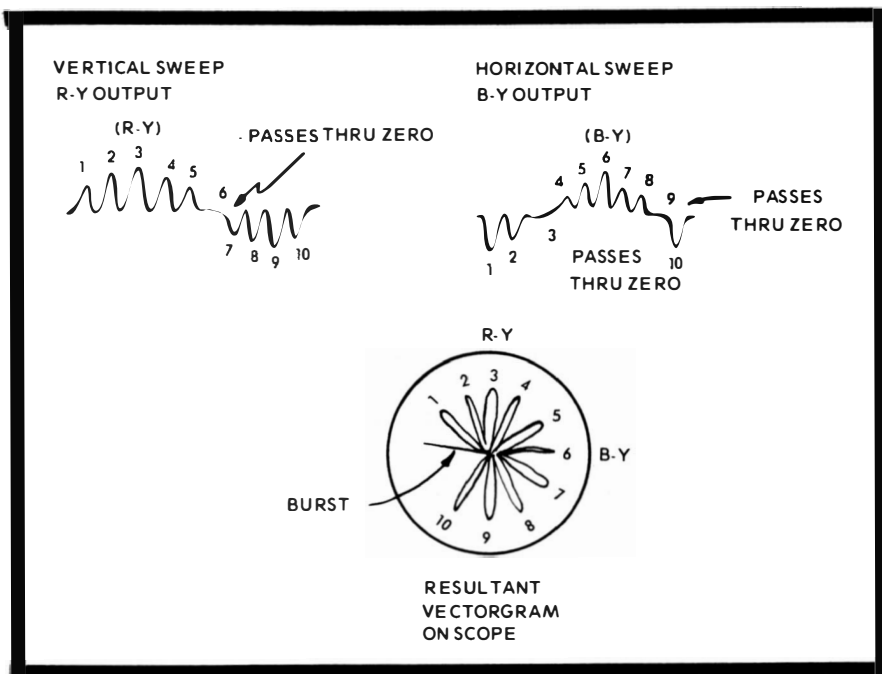

Fig. 34. When you sweep a scope vertically with R-Y and horizontally with B-Y from a color generator, the "daisy" display is formed.

way, short out the test point between the phase detector and reactance amplifier. The petals will whirl. Adjust the plate coil of the reactance amplifier until the petals just float by. (Yes, same test as in the AFPC.) Then, remove the short. The petals should lock into place.

During troubleshooting, the vectorgram will display trouble in these circuits. However, there are few set patterns and the analysis is too complex to be much help in routine color TV servicing.

### No. 37: STAGGER-TUNED IF ALIGNMENT

In FM and TV receivers, it is usual to employ more than one IF stage in order to get enough amplification. A common design is the stagger-tuned IF strip using three or four stages. They can be either tube or solid-state. Both designs are similar. The IF band in an FM receiver has a center frequency of 10.7 MHz. The bandwidth is typically 200 kHz. The IF bandwidth in a TV receiver is usually centered at 44 MHz. The bandwidth is typically 6 MHz in order to pass the video, sound

and color carriers. The three stages are “stagger tuned,” each to a slightly different frequency so each stage can pass and amplify different parts of the bandwidth. The result is an overall response equal to the desired bandwidth.

Typically, in an FM receiver, one stage amplifies at 10.7 MHz, another stage at 100 kHz above and the other 100 kHz below. A TV receiver has one stage set at 44.25 MHz, another at 45.75 MHz, and the other at 42.17 MHz. This staggering of the tuned frequencies enables the full 200 kHz in the FM and the full 6 MHz in the TV to pass easily.

Also, with stagger-tuned stages, there are traps to get rid of adjacent-channel signals. In a color TV there is a trap to suppress the sound carrier so it beats as little as possible with the color subcarrier and thus produce a minimum of 920-kHz beat interference, which appears as annoying interference (TVI).

The alignment procedures for an FM radio and a TV are quite similar in general approach, although each has its own “quirks” of design. Various special jigs and bias voltages have to be used in order to adapt to the peculiarities of various AGC and IF designs. It would be impossible to cover these in this discussion. You must have the actual service and alignment notes to do a specific alignment job according to the factory specifications. Our purpose is to explain the object of alignment and the frequencies involved. They are universal and dictated by the FCC and station transmission standards.

A TV set receives all VHF and UHF channels. They all have different carrier frequencies. However, as you know, the tuner tunes them all individually, no matter whether it's Channel 2 or 82, and applies the selected signal to the conventional 44-MHz IF.

When the carriers are changed to the IF, they are reversed in order. The sound is now lower than the video; the sound is 41.25 MHz and video at 45.75 MHz. The color subcarrier is located between sound and picture, 920 kHz above the sound at 42.17 MHz. The center frequency is not exactly at 44 MHz but at 44.25 MHz (Fig. 35). There are two other frequencies that have to be worried about. They are the adjacent-channel sound at 47.25 MHz and adjacent-channel video at 39.75 MHz.

They are the six frequencies that have to be considered. Each frequency on the IF scale has to be placed at a different amplification level. In the input of the first IF is usually a trap tuned to the adjacent-channel sound at 47.25 MHz. This trap has to be aligned so that it suppresses adjacent-channel sound as much as possible (Fig. 36). Adjacent-channel sound

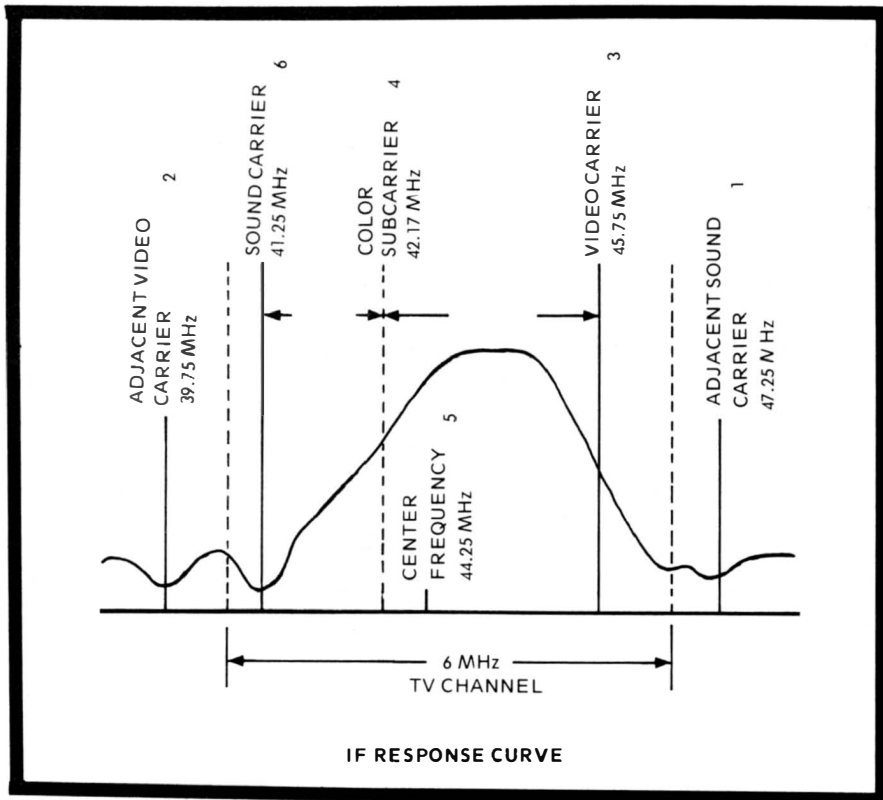

Fig. 35. On the IF response curve the audio and adjacent-channel carriers are suppressed. Color and video signals appear at 50 percent.

produces a herringbone interference on the screen if it is not suppressed. In fact, if you have excessive adjacent-channel sound, you can try eyeballing the interference out by touching up the trap.

Also, in the input of the first IF is another trap tuned to the adjacent-channel video at 39.75 MHz. (Notice that the adjacent-channel sound is from the channel below and the adjacent-channel video is from the channel above.) This trap has to be aligned so that it suppresses adjacent-channel video as much as possible. Adjacent-channel video produces a windshield wiper interference on the screen if it is not suppressed. In fact, if you have adjacent-channel video, you can try eyeballing it out by touching up this trap.

The coupling transformer from the first IF to the second IF is usually tuned to the video carrier at 45.75 MHz. This transformer has to be adjusted until the 45.75-MHz video marker sits approximately 50 percent on the slope of the IF bandpass response curve.

Fig. 36. These six alignment stations are found in practically all color TVs that use stagger-tuned IF strips.

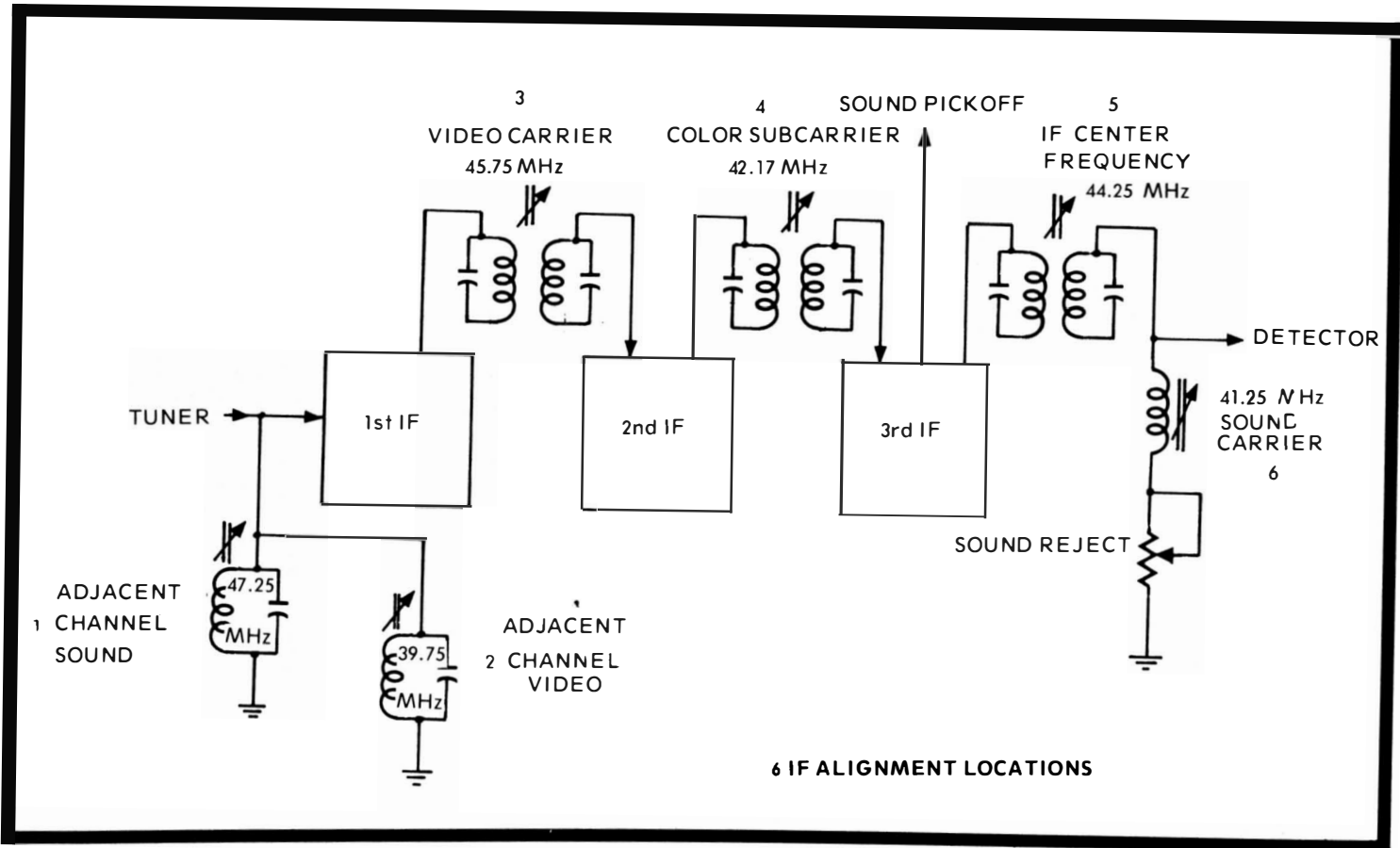

The curve appears on the face of the scope and is produced with sweep generator and marker generator signals applied to the TV according to the service notes. Various bias voltages are applied to the IF to sit the desired amplification levels. The scope picture is the detected bandpass curve. (The IF frequencies around 44 MHz are not displayed on the scope, their detected resultant is.)

The coupling transformer from the second IF to the third IF is usually tuned to the color subcarrier at 42.17 MHz. This transformer has to be adjusted until the 42.17 MHz color subcarrier marker sits approximately 50 percent down on the other slope of the IF bandpass response curve. When this transformer is misadjusted, it can cause a weakness or a complete loss of color. (It is not advisable to try to eyeball the color back in by adjusting this transformer, unless it is a TV that you are familiar with and know that this transformer is a problem.)

The coupling transformer from the third IF to the detector stage is usually tuned to the middle of the bandpass at 44.25 MHz. It has to be adjusted to linearize the center of the bandpass. There needn't be a marker for this frequency.

In the output of the last IF is a trap in series with the sound-reject potentiometer. The trap is tuned to the sound carrier of the channel being received. It has to be adjusted, along with the sound reject, to suppress the sound carrier as much as possible.

The sound is typically tapped off in the third IF stage. After the sound pickoff, the carrier must be suppressed, or it beats with the color subcarrier, producing a 920-kHz signal. You can eyeball the 920-kHz beat out of the picture by adjusting the trap and sound reject. You might get more color intensity, too, since you will be adjusting the slopes of the response curve at the same time.

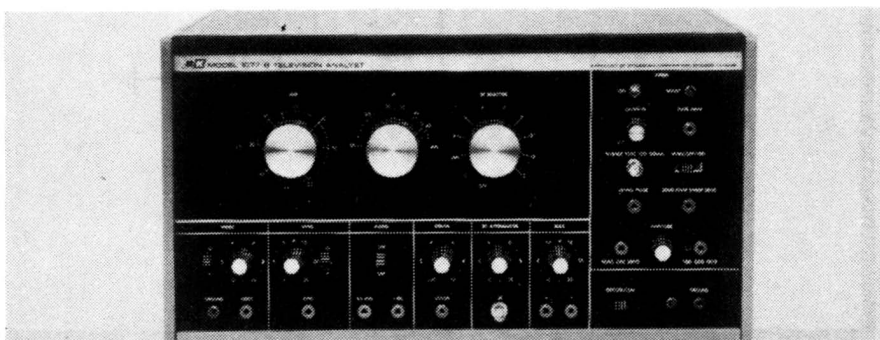

B & K TV Analyst, Model 1077-B, produces a complete array of TV test signals.



## No. 38: DC HI-VOLTAGE TEST

DC high voltage, as its known in some receivers, is used to accelerate the electron beam in a cathode ray tube. It is an RF voltage produced during the horizontal flyback interval, rectified and sent through a heavily insulated wire to the anode of the CRT. It is vital that the correct voltage level be maintained. Too little can produce dark displays, hard-to-adjust displays and all kinds of distortions. Too much high voltage can produce unwanted X-ray effects, posing a potential hazard.

Any good voltmeter properly equipped with a multiplier resistor encased in a specially designed high-voltage probe can produce an accurate reading. The TV is turned on and the probe attached to the voltmeter. There are some special voltmeters mounted on probes that are built especially for this test (Fig. 37).

The test is usually conducted in two ways: one, with the brightness turned all the way up and another with the brightness extinguished. With the brightness turned all the

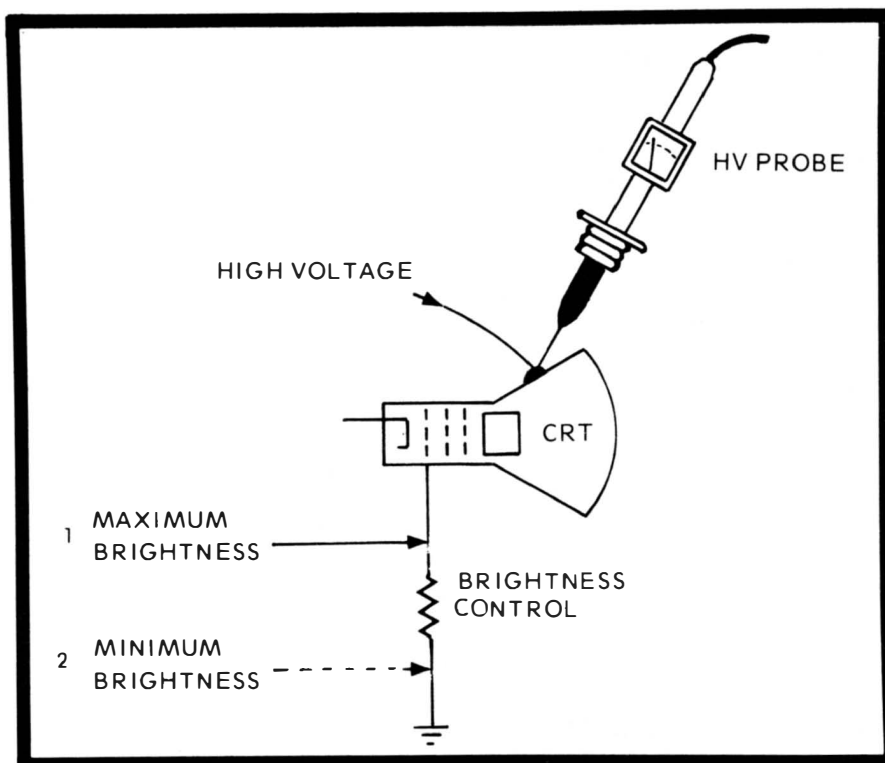

Fig. 37. The HV in a color TV is measured at maximum and minimum settings of the brightness control.

way up, a maximum electron emission occurs at the CRT gun or guns and the flyback system draws the maximum amount of current. In other words, the system is running wide open. With the brightness turned off, there is no electron flow from the guns and the flyback system draws little or no current. A comparison between the two states gives a rough idea of the efficiency of the flyback system. Too much of a voltage difference means the system is not operating properly.

### No. 39: RF—IF SCOPE SIGNAL TRACING

As the signal passes through a radio or TV receiver, it is processed in numerous ways. At various stages the signal is amplified, heterodyned, shaped, trapped, certain frequencies extracted, and so forth. Good servicing technique dictates that the servicer knows what the signal looks like on a scope as it passes through the receiver. When the signal is tiny (in the low microvolts), it is difficult to get a good scope picture. As the signal is amplified and detected, the scope pictures get better and better.

Two main scope probes are used. One is the demodulator probe and the other is the high-impedance or, as it can be called, a low-capacitance probe. Direct probes can sometimes be used, but in almost every case a high-impedance probe will also work. The direct probe can load down a circuit with the scope's input impedance. The high-impedance probe, as the name implies, isolates the scope from the receiver being tested and in almost all cases is more accurate than the direct probe (Fig. 38).

The demodulator probe is used to look at signals while they are still modulating the carrier wave, whether it is RF or IF. The probe contains its own AM detector which detects the signal at the test point being observed. In a radio and TV receiver a demodulator probe is used when the RF-IF area is inspected. If the probe is touched at the output of the last IF, the same picture appears as would be seen if the output of the receiver's detector were observed with a high-impedance probe. In fact, the reason for the test is to see if the signal is getting to the output of the last IF and if the detector is a trouble suspect.

If the probe is connected to the input of the last IF, the same detected display will appear, except that it is considerably less in amplitude. That's because the display shows what the signal looks like before it passes through the last IF and amplified many times. The output of the second IF shows the same signal as the input of the third IF. The only com-

ponents the signal has to pass through is the IF transformer and perhaps a blocking capacitor. These components neither amplify or attenuate the signal to any appreciable degree.

A scope picture taken at the input of the second IF shrinks in amplitude even more. Lots of inexpensive scopes will not even have enough gain to display the second IF input signal, it is so weak.

The scope picture taken at the input of the first IF is miniscule if the scope has enough power to even display it. Scope pictures on ordinary service bench equipment taken in the mixer-oscillator or RF amplifier do not produce any display. There are more expensive industrial type scopes that will produce displays taken from the tuner. However, on most servicing jobs such large amounts of amplification are not needed.

#### No. 40: VIDEO SWEEP MODULATION TEST

The bandpass amplifier is tuned in an odd way. In addition to having to pass the color sidebands centered around 3.58 MHz on the 6-MHz TV passband, it has to amplify one side of the sidebands more than the other. This is because the color subcarrier is stationed 50 percent up on the slope of the passband and the IF, as a result, amplifies the higher part of the slope much more than the lower part of the slope. The bandpass amplifier must amplify in a way to complement the IF method of amplification and produce an equal response of the color sidebands.

The method used is called video sweep modulation. Marker and sweep generator signals are injected into an RF

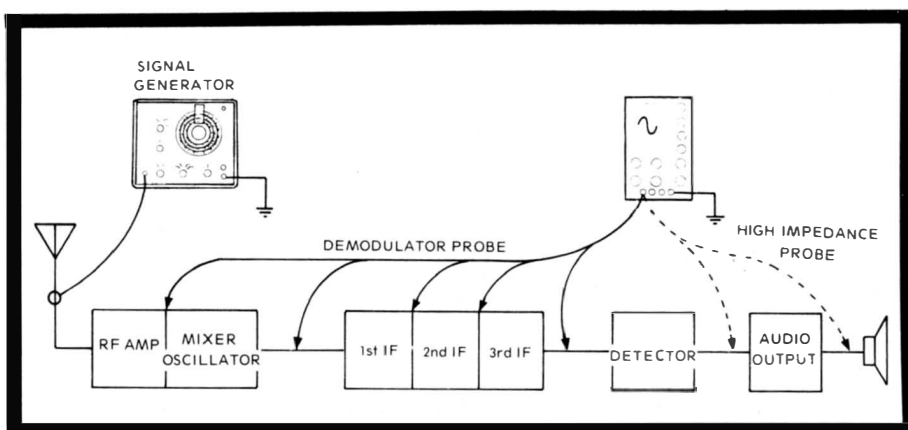

Fig. 38. Signal tracing through a receiver is easy when you have a scope, generator and correct probes.

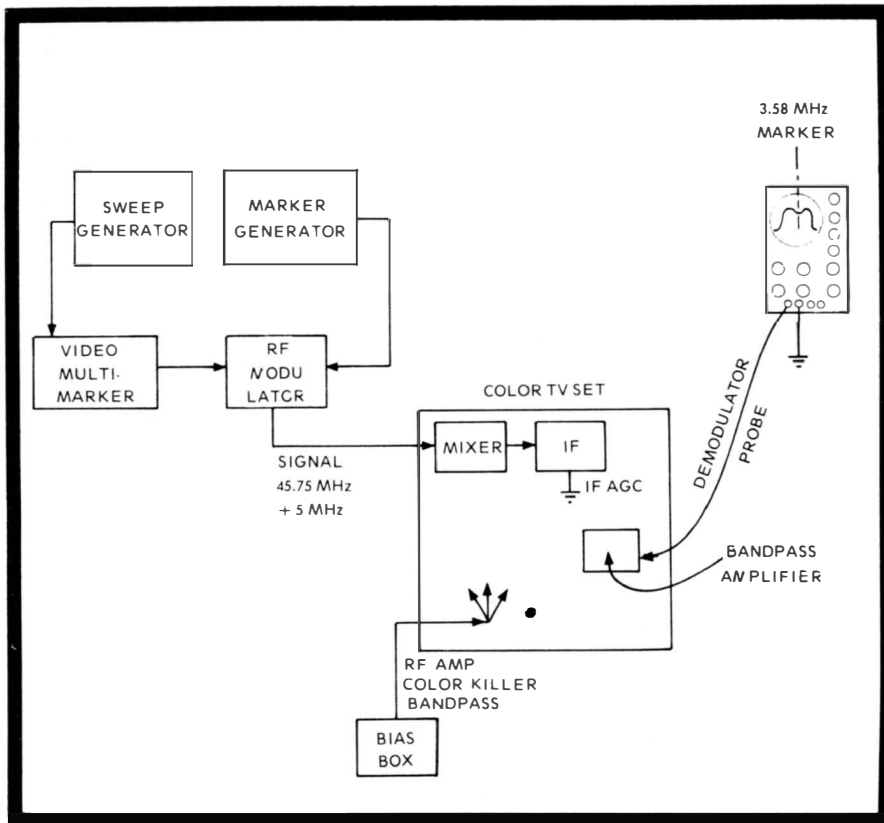

Fig. 39. The color TV VSM (video sweep modulation) is a complicated hookup for just bandpass adjustments.

modulator. This produces a picture carrier at 45.75 MHz which is modulated with a video-type signal with a bandpass of zero to 5 MHz. The signal is attached to the TV receiver before the IF stages. The output of the IF is detected and the 45.75-MHz carrier is eliminated. The video type sweep is fed to the bandpass amplifier and the color sidebands are amplified on either side of 3.58 MHz.

A scope equipped with a demodulator probe is used to detect the 3.58-MHz color subcarrier. The color sidebands are then displayed on the scope. They should be linear. If they are not, the bandpass amplifier transformer is touched up until the sidebands look good (Fig. 39).

#### No. 41: HIGH-IMPEDANCE PROBE TEST

While the demodulator probe permits you to look into RF-IF and color IF circuits, the high-impedance probe permits you to

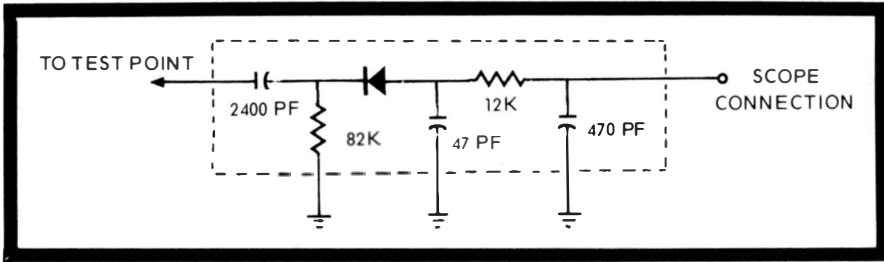

Fig. 40. A typical demodulator probe contains an isolation and detection circuit like an ordinary AM detector.

look into the rest of radio or TV circuits. The demodulator probe is equipped with a diode detector (Fig. 40), and the high-impedance probe is simply a low-value variable capacitor, typically 6-30 pf, and a high-value resistor, typically 10 meg, in parallel (Fig. 41). This allows you to probe a circuit and prevent the impedance of the scope from loading down the circuit under test. In other words, the two components isolate the scope from the circuits under test.

The high-impedance probe is attached to the vertical input of a scope using an internal sweep for the horizontal. The internal sweep is set near the frequency of the circuit under test. For example, if the circuit has a 60- or 120-Hz signal in it, the internal horizontal sweep is set at 60 or 120 Hz. If the internal sweep is identical to the circuit under test, there will be a single display, as the same frequencies come into view both vertically and horizontally. If you are testing a circuit and want to see a double-peaked display you set the internal sweep at half the incoming signal frequency. Then the test frequency will appear twice during each internal sweep.

The probe will accept all frequencies up to the response limit of the scope. You can use the same probe with a scope that has a frequency response of 3 MHz as a scope with a frequency of 10 MHz. The high-impedance circuit in Fig. 38 can be rigged up if you'd like and attached in series with a direct probe.

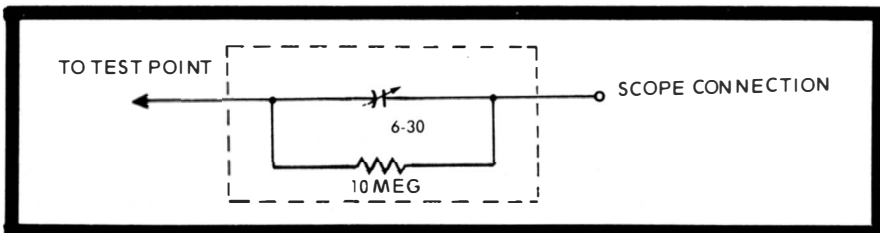

Fig. 41. A typical high-impedance probe isolates the scope from the circuit under test and reduces any loading.

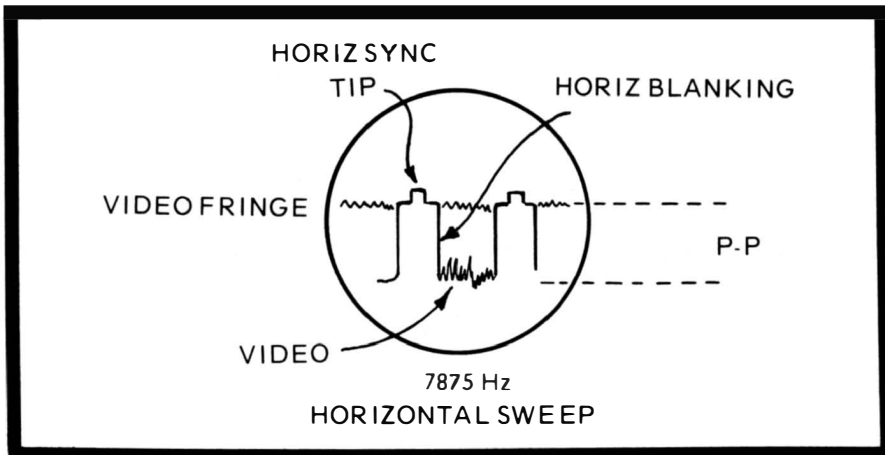

Fig. 42. The typical video picture displayed on the scope has visible sync pedestals and "writing" video.

#### No. 42: VIDEO EXPLORATORY TEST

In black-and-white and color TVs, there is a circuit area that processes the video signal. The video signal is also called the Y signal or luminance. The video leaves the detector stage and passes through the various video amplifiers and then into a video output. At that point it is large enough to drive a CRT and is applied to the monochrome or polychrome CRT.

The big problem with the video is that it contains frequencies between zero and 4.5 MHz. Where a picture element has to change from black to white, the speed with which it performs this job approaches the 4.5-MHz frequency. There are special components in the video strip that permit such high frequencies to pass. They are parallel and series peaking coils, low-value output resistors and large capacitance units.

A defect in the video can range from no video to smeared video or too much video. A scope equipped with a high-impedance probe permits a look into the video at various test points to determine if the video is there and give you a rough idea of its quality.

The input and output of the video stages are the best test points. Most factory service notes have peak-to-peak pictures of what the video waveform should look like (Figs. 42 and 43). The scope is connected at these test points and the picture analyzed. The shape of the video, the appearance of the sync and blanking pulses and the relative peak-to-peak voltages are all observed carefully. Any deviation from the normal pictures indicates a nearby defect.

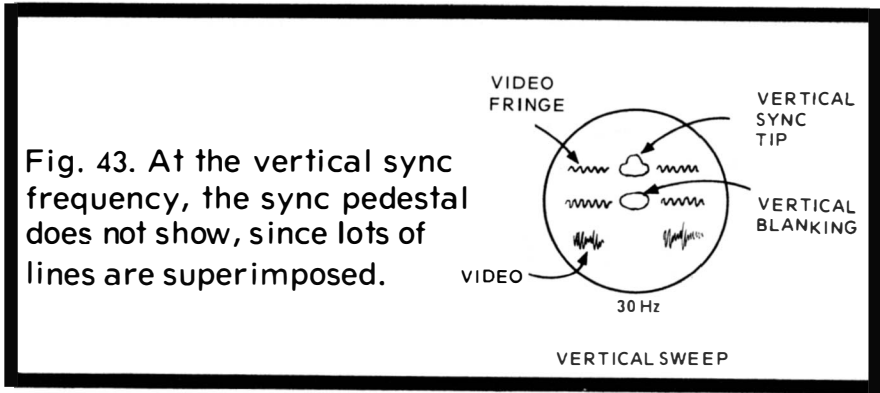

**No. 43: SYNC EXPLORATORY TEST**

In black-and-white and color receivers, there is a circuit area that processes the sync pulses transmitted by the TV station. There are many different types of sync circuits, but they all must do just about the same job.

A sampling of the video is taken from a junction in the video detector or video amplifier. It is passed through some series resistors and capacitors that clean up the video a bit. Then, the video is passed into a sync separator. If the sampling is taken at the video detector, it is sometimes not strong enough to work in the separator and is passed through a sync amplifier before the separator gets it.

In the separator the bias is set so that the tube or transistor is cut off during the interval that the video is passed through it. However, when the larger peak-to-peak sync pulse is applied, the separator turns on and amplifies that pulse. In this manner only the sync pulse passes and thus is separated from the video (Figs. 44 and 45). The separated sync pulses

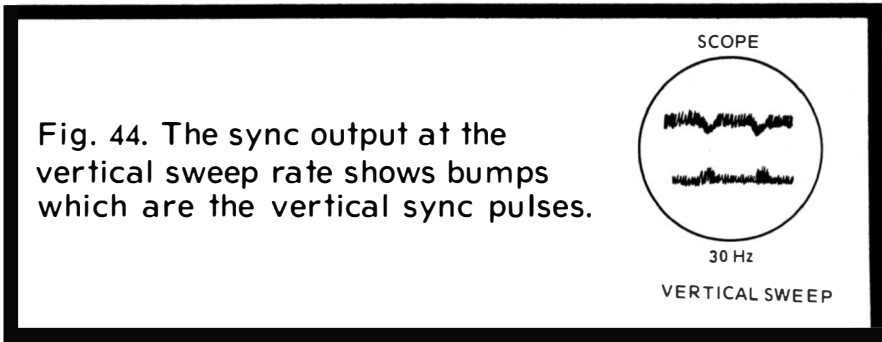

## HORIZONTAL SWEEP

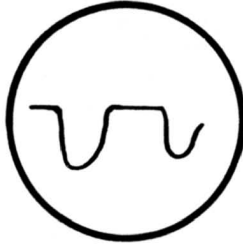

7875 Hz

Fig. 45. The sync output at the horizontal sweep rate shows spikes which are from the sync pedestal.

are sent on to the vertical and horizontal oscillators through the integrator and differentiator.

Probably the fastest way to service sync circuits is by a scope examination, using a high-impedance probe. The scope probe is touched to the various components, starting in the sync takeoff line and proceeding step by step through the sync circuit. If the peak-to-peak value or appearance of the sync pulse as it is processed is incorrect, it is an indication that the cause of the trouble is near.

### No. 44: COLOR EXPLORATORY TEST

In color receivers, the Y signal is fed to the cathodes of the color CRT and the R-Y, B-Y and G-Y color signals are fed to the control grids. The output of each gun, as the cathodes and control grids mix the signals, are pure R, B, and G.

The R-Y, B-Y and G-Y signals are usually produced in the color demodulators. The color demodulators are fed color sideband signals from the color IF (bandpass amplifiers) and properly phased signals from the color oscillator. In the demodulators the sidebands are mixed with the CW from the oscillator and the color carrier is reconstructed and appears as it did before it was suppressed at the transmitter less than a second before.

At the output of the demodulators, carrier is confronted by small capacitors to ground. The capacitors by-pass the carrier leaving the R-Y and B-Y signals intact. The R-Y is sent to the R-Y amplifier. The B-Y is sent to the B-Y amplifier. Both the R-Y and B-Y are sent to the G-Y amplifier where they combine



electronically and produce G-Y. The R-Y output is applied to the red gun control grid, the B-Y to the blue gun control grid and the G-Y to the green gun control grid. The scope equipped with a high-impedance probe produces a picture of this entire process step by step. All you have to do is connect the scope probe at the various test points and observe carefully the scope display for both peak-to-peak value and quality.

The scope exploratory is best conducted if a fixed color-bar signal is sent through the TV. The first place to check is the output of the demodulators. The outputs should look about the same, except that the amplitude of the bars are slightly different. It is a picture of a modulation envelope complete with CW.

The next place to touch the scope probe is past the carrier by-pass capacitors, which are in the R-Y and B-Y amplifier inputs. The same scope picture should be there, except the CW is stripped off. The other test points are the outputs of the color difference amplifiers. All three scope pictures, at first glance, should look alike; however, a closer analysis reveals that the bars are passing through the zero line at different places. In the R-Y waveform the sixth bar should be passing through zero. In the B-Y waveform the third and ninth bars should be passing through zero. And the seventh bar in the G-Y waveform should be passing through zero.

The correct placement of the bars is vital to the color picture. If you should find bars not passing through zero junctures, the waveform is incorrect and the display means that the colors are not being processed properly. On the ordinary scope, pictures taken at the oscillator output will show a solid CW envelope. In order to actually see the waveform, the scope has to be set at a sweep frequency of 3.58 MHz. Most scopes cannot sweep that high.

## Chapter 6

# Antenna Systems

### No. 45: CALCULATING THE DECIBEL—ANTENNA SYSTEMS

The end result of a receiver is sound developed in the surrounding air by the speaker cone. This wave passes through the air, and the size of the resulting compression and rarefaction determines the amount of loudness the ear hears. Small pressure changes produce low sounds while large pressure changes are sensed by the ear as loudness.

Strangely, the ear does not hear the differences in volume as a direct result of the increase in the wattage output of the speaker. If loudness is increased, the ear hears less and less of the total the higher the volume gets. The ear can pick up low volumes, but it is not overwhelmed easily as the volume is turned up. The ear responds to sound in a logarithmic manner. This makes calculations of wattage output difficult to relate to the human ear response, so a conversion figure is used. It is the decibel.

It is useful to figure all signal strength in terms of decibels. This means the transmitter signal, the antenna pickup signal, the signal as it's amplified and the speaker output signal. Gains and losses in various sections of the transmitter and receiver are quite often calculated in db gain or db loss.

The human ear does not actually hear the difference between two loudness levels as an exact logarithmic function. The human ear hears the loudness change approximately the same as the value relationships in a log table. The approximation varies widely from person to person. It is quite useful, though, to be able to add the response in db rather than work out ratio problems. Therefore, the decibel is quite useful.

The db is calculated either from wattage readings, voltage readings or current readings. These are accomplished with a wattmeter, voltmeter or ohmmeter. If you want to calculate the db increase in a transmitter output change, it's done like

this: The original wattage output is taken and the increase is also noted. Suppose the transmitter power has been increased from 20 watts to 80 watts. The formula is :

$$\begin{aligned} \text{db} &= 10 \log \frac{\text{power new}}{\text{power old}} \\ \text{db} &= 10 \log \frac{80}{20} \\ \text{db} &= 10 \times 0.6 \\ \text{db} &= 6 \text{ gain} \end{aligned}$$

This says that the db increase was a result of multiplying the power by 4, from 20 to 80 watts.

On the other hand, suppose you install an antenna system and you want to calculate the db loss in the line. This is another type of calculation. The transmitter output increase is a power ratio. The antenna line loss has to be calculated with a voltage ratio or to be exact, a microvolt ratio. The term decibel is an arbitrary characteristic and is a result of ratios. To simplify the antenna decibel figuring, the TV industry decided to set 1000 microvolts as the zero db point. The 1000 microvolts must be across 75 ohms, a value that produces a satisfactory TV picture. You'll see dbj or dbm for this figure, but it is only db. The figure cannot be computed unless the input and output impedance is the same. This is mandatory.

The next thing is to take the microvolt readings. First a reading with a field strength meter is taken of the lead-in output. Suppose it is 5000 microvolts. Then the reading is taken at the input. Suppose it is 10,000 microvolts. According to the formula :

$$\begin{aligned} \text{db} &= 20 \log \frac{\text{voltage output}}{\text{voltage input}} \\ \text{db} &= 20 \log \frac{5000}{10,000} \\ \text{db} &= 20 \times 0.07 \\ \text{db} &= 1.4 \text{ loss} \end{aligned}$$

This says that there is a 1.4 db loss in the line. Notice that the actual microvolt level dropped in half, but the db loss is small.

Current db losses and gains are computed with the same formula as used for voltage. Again, the impedances must be the same if input and output readings are made. Otherwise, the ratio is incorrect.

No one in the field actually works out a formula to compute the db loss or gain. It can be taken directly off a decibel

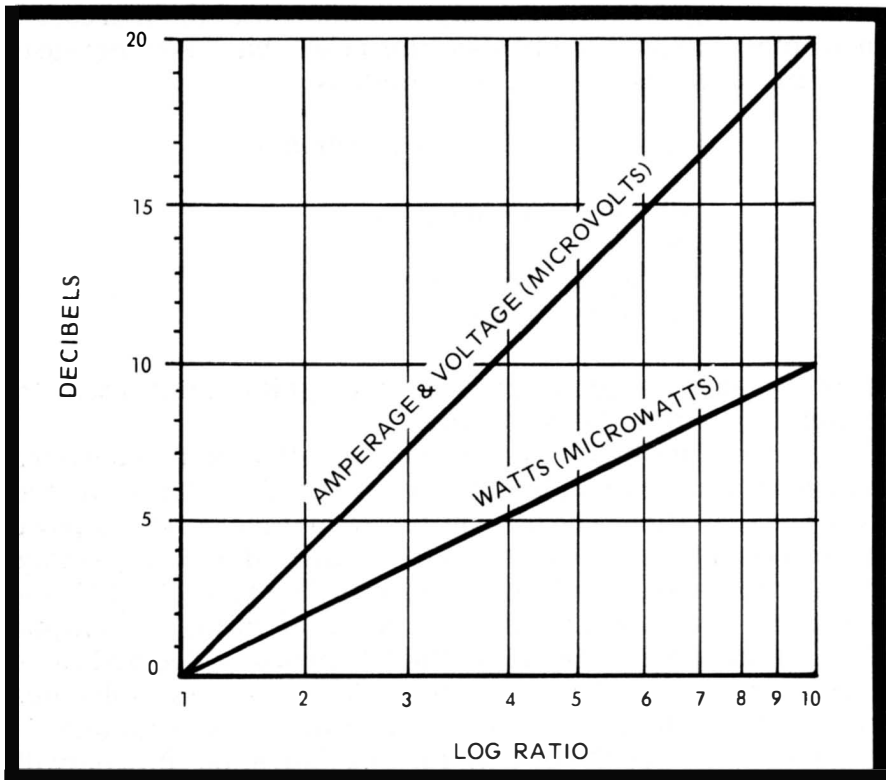

Fig. 46. The various signal parameters are difficult to handle until they are converted into decibels.

chart (Fig. 46). The decibels are the vertical axis and the spaces between zero and 20 are equidistant. The ratio, either wattage, voltage or current is the horizontal axis. The ratio numbers from 1 through 10 are not spaced equidistant. The spacing gets smaller between each succeeding number on what is called a logarithmic scale. Notice that zero on the decibel scale is one on the ratio. This corresponds to the zero level of db being set at 1,000 microvolts.

You'll notice that the power formula uses a multiplier of 10. Therefore, we can draw a characteristic line from the intersection of zero and one to the intersection of 10 and 10. This gives us all the power figures. The ratio of the powers is converted directly to decibels along the line.

You'll also notice that the voltage and current formulas use a multiplier of 20. Therefore, we can draw a line from the intersection of zero to the intersection of 20 on the decibel scale and the 10 of the log scale. All along this line, the voltage or current ratio can be converted directly to db.

The chart can be used for any power ratio by simply adding 10 db for every time the ratio is multiplied by ten. This is used for either losses or gains. A loss is a minus db and a gain is a plus db. For instance, suppose you have a power ratio of 4. Then there is a gdb change. Suppose then the power ratio is changed to 40. Simply add 10 to the gdb charge and get 16. Suppose the power ratio becomes 400. Add another 10 to the 16 and get 26. This is true for gains or losses. The same ratios occur and a loss is recorded as minus db.

#### **No. 46: TV MICROWATTS**

The strength of received signals is usually thought of in microvolts or db. This is because we are always dealing with a fixed impedance of either 72 ohms or 300 ohms. Actually, microvolt reading by itself is almost meaningless. The microvolt level at 72 ohms is just about half of what is received at 300 ohms, yet they produce the same picture or sound. This is because the important figure is microwatts not microvolts. Microwatts is computed with the single formula  $E^2R$ . For instance, suppose you have a 1000-microvolt signal being picked up by a 300-ohm antenna. The  $E^2R$  is .0033 microwatts. Then, you install a matching transformer with no losses between the antenna and the lead-in which is 72-ohm coaxial cable. The output of the transformer would drop to 500 microvolts.

Is there a loss? No, because the microwatt level remains the same.  $E^2R$  has  $(500)^2 \times 72$  which is still .0033 microwatts. Even though the microvolts level drops in half, the power in microwatts remains the same. It's the power that drives the receiver circuits, not the microvolts (Fig. 47).

Keep the relationship between the two impedances in mind. As you test for db or microvolts, realize that twice as many microvolts is needed in a 300-ohm system than in the 72-ohm system. It's the same amount of signal in the air and the same amount of power produced. When an FSM is calibrated for 72 ohms, just multiply the microvolt reading by two.

#### **No. 47: FIELD STRENGTH TEST**

In weak signal areas, RF pickup is spotty. There are places in the air space above a roof where the signal is weak. Then a few feet away, the same frequency is stronger. Of course, it would be best to position the antenna system in the spot where the signal is at maximum. As the wave travels through the air it has peaks and nulls (Fig. 48). The antenna that is placed in the

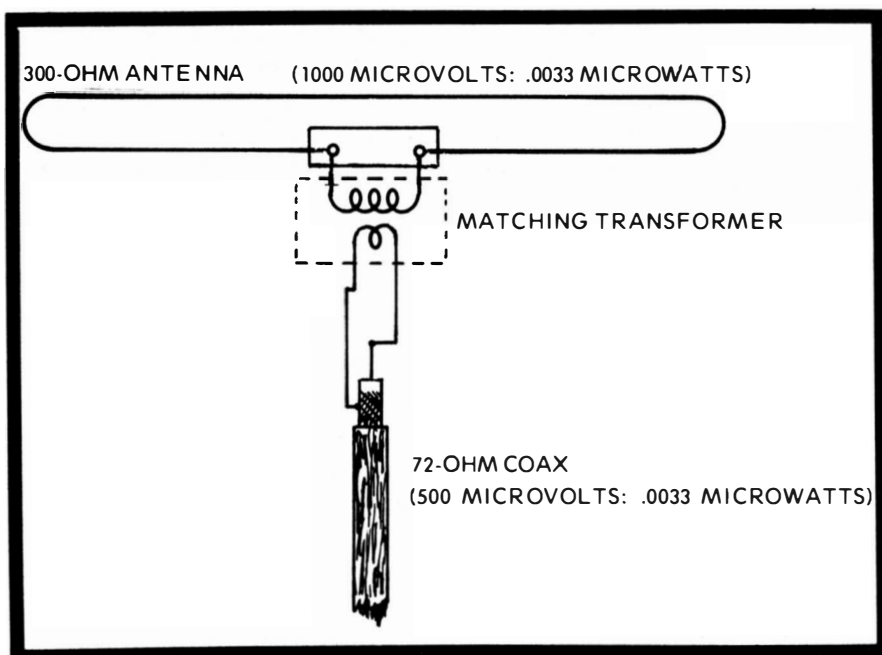

Fig. 47. When you match impedance correctly, even though the microvolts change in number, microwatts remain the same.

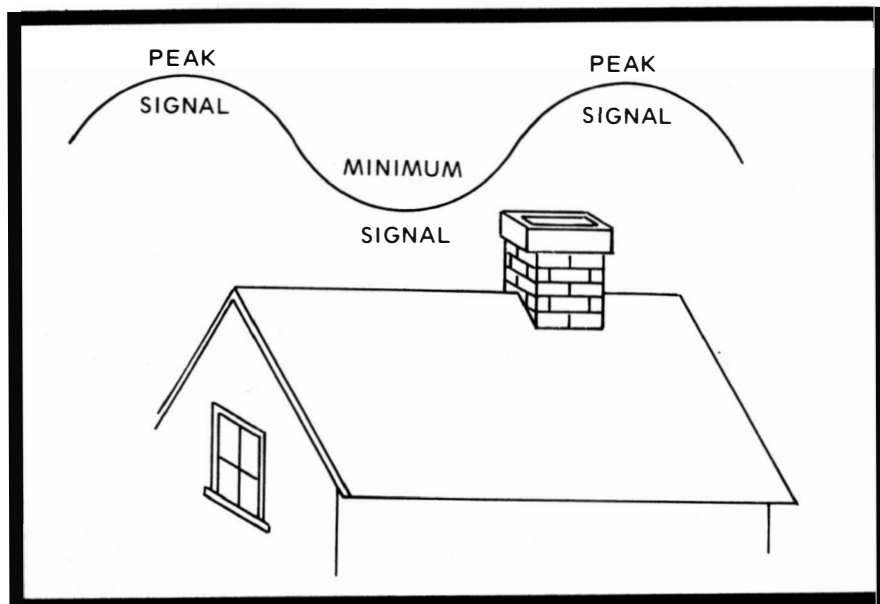

Fig. 48. A field strength meter can pick out exactly the peaks and minimums of signal in the airwaves.

peak intercepts the maximum available signal. The peak can be located with the aid of an antenna and a field strength meter.

A typical fine field strength meter is the Sencore FS 134. It is battery-operated and small in size. Carry such a meter to the antenna site and attach an antenna to it. Take care that the lead-in used is the correct impedance. The usual impedance of the lead in is either 72 or 300 ohms. Provisions on the typical FSM are usually made to accept the lead-in.

The antenna is attached to the meter, the meter turned on and set at the desired frequency. Then you walk around the roof holding the antenna high and observe the meter. As the antenna is changed from spot to spot, height to height and direction to direction, the actual microvolt reading is observed. When the meter reads maximum, the best picture or sound will be received. It's a good idea to probe near the center of the roof or over a chimney so the actual installation is easier.

#### **No. 48: FIELD INTENSITY TO SIGNAL STRENGTH RELATIONSHIP**

Confusion between field intensity and signal strength is common. They are both measured in microvolts but they are not at all the same. The field intensity is the number of microvolts induced in a conductor one meter long as the RF passes through the conductor at the speed of light.

Stations plot the field intensity of their allocation and publish a field intensity map. This map is useful. It typically depicts a contour of 500 microvolts (Fig. 49). That is, it shows the field intensity from its primary area at ground zero on out to where the signal is dissipated down to 500 microvolts. Any further than that is a deep fringe area.

On the other hand, signal strength is the number of microvolts present at the antenna system output. It is the signal "made" by the antenna. The field intensity induces a current in the antenna. The current flows down the lead-in and out into a matched impedance. The amount of signal produced is the signal strength.

You can determine what kind of antenna array you need by figuring out how much signal is necessary to drive a receiver, then calculate what kind of antenna will produce that much signal.

The practical way to make your signal survey is with a set of rabbit ears and a field strength meter (Fig. 50). Remove the 300 ohm-ribbon lead-in from the rabbit ears and replace it with



Fig. 49. Field intensity plots are calculated carefully for each transmitter.

a piece of 75-ohm coaxial cable like the RG59 B-U. Adjust the rabbit ears for the exact wave length of the station you want to receive. A quarter wave length is arrived at for each arm in feet:

235

Freq. in MHz

Then begin taking microvolt readings at the antenna site. You can mount the rabbit ears on the end of a clothes pole or other convenient piece of wood. Do not use metal because the wire is loose and will be affected by mutual coupling.

The readings you get will be the reference for your antenna installation. All antennas are rated against a straight



half-wave dipole (two quarter-wave arms on the rabbit ears). If you want an antenna that will produce ten times as much signal in microvolts as your reference dipole, purchase an antenna that has a 20 db rating at the desired frequency. If you can get by with only three times as much signal, get an antenna with a 10 db rating. The db rating is logarithmic in comparison to the signal strength.

Zero db is an arbitrary figure and is set at 1000 microvolts. Minus 20 db is 100 microvolts and minus 30 db is 30 microvolts. Anything under 30 microvolts is usually too weak for use and cannot be read on the typical field strength meter. Signal strength is referred to as either db or microvolts. They both mean the same thing and are simply a microvolt number of its logarithm.

#### No. 49: CHECKING SIGNAL GENERATOR OUTPUT

During FM radio servicing, especially, and TV also, it is necessary to produce a sufficient microvolt level with a signal

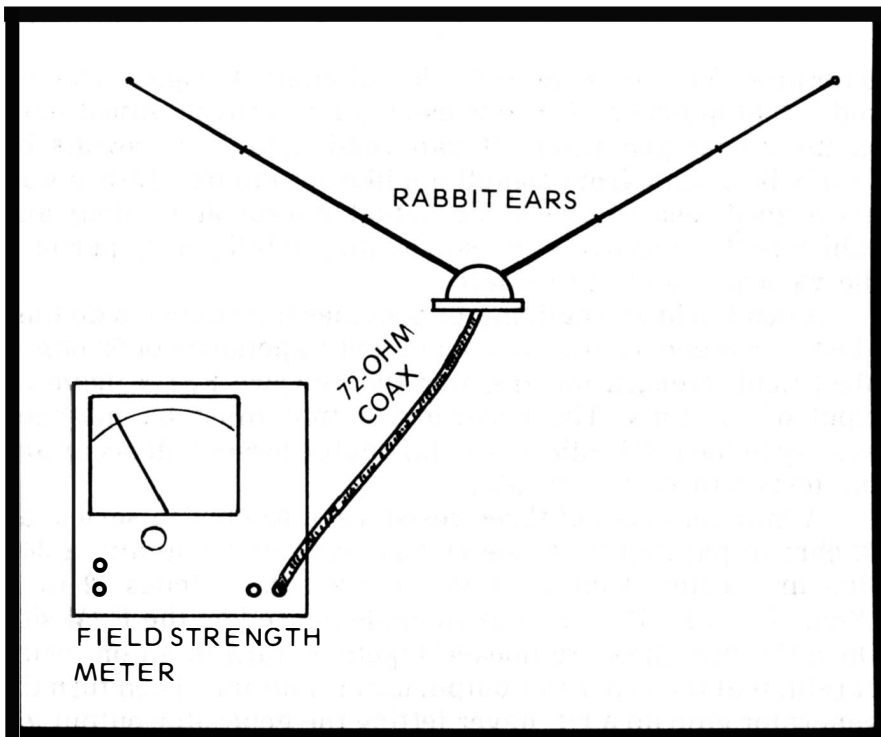

Fig. 50. To conduct a satisfactory signal strength survey test, ordinary "rabbit ears" can be used.

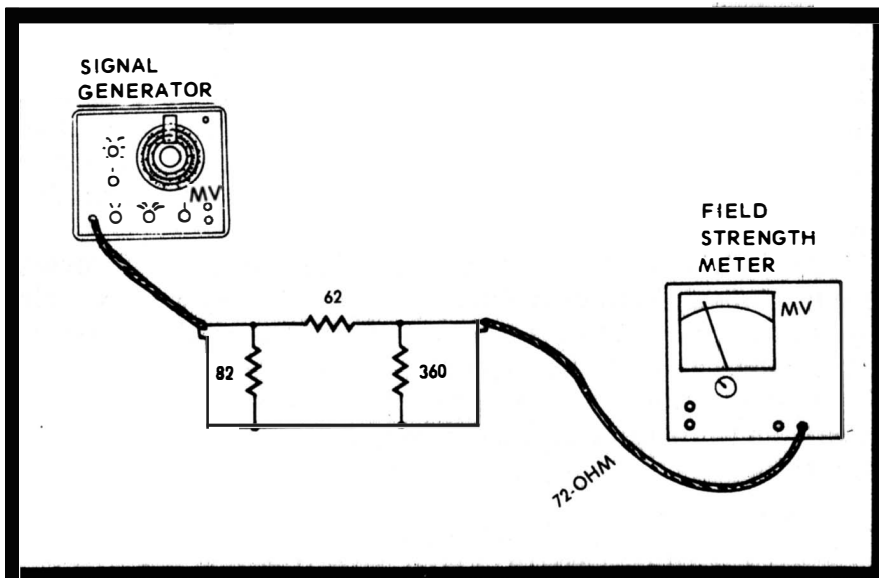

Fig. 51. A dandy way to accurately test your signal generator output is by padding it into an FSM.

generator. This is mandatory for alignment, signal tracing and signal injection. There is usually a microvolt adjustment on the signal generator. It can read actual microvolts or simply be a scale from something like zero to ten. Either way it's a good idea to check the actual microvolt reading and calibrate the microvolt dial so you may intelligently perform the various testing procedures.

A good field strength meter provides the means to do this. Most signal generators have an output impedance of 52 ohms. Most field strength meters, like the Sencore FS134, have an input of 72 ohms. The generator output must be matched exactly to the FSM; otherwise, mismatch losses will occur and the tests will be inaccurate.

A matching pad of three resistors, a 62-ohm in series, an 82-ohm in parallel from the signal generator side and a 360-ohm in parallel from the FSM side which matches 52 to 72 ohms (Fig. 51). 75-ohm coaxial cable is used on the FSM side. Once the two units are hooked together, turn them on, being careful that the generator output is at minimum. Then turn the generator gain up a bit, never letting the generator output get above a readable indication. If you overload the FSM, which is easy with a signal generator, the meter can be hurt. Calibrate the dial according to the FSM readings.

## No. 50 STANDING WAVE RATIO; SWR IMPEDANCE TEST

In the field during an actual antenna installation, the input and output impedances vary with equipment used. From a practical standpoint, quite a bit of mismatching is tolerable. But the amount of mismatching is good to know in case you must improve reception. If there is a lot of mismatching, some of it can be corrected with matching gear.

The SWR is calculated easily by using the simple formula :

$$\frac{\text{Load Ohmage}}{\text{Line Ohmage}}$$

If a 300-ohm line is terminated in a 300-ohm folded dipole (300 divided by 300 equals 1, which is no SWR (Standing Wave Ratio)). On the other hand, if a 300-ohm line is terminated in a straight dipole with an impedance of 75 ohms, then 300 divided by 75 equals 4. This reveals a 4-to-1 mismatch (Fig. 52).

This same type of consideration is used when figuring the line impedance as it is terminated at a receiver. Suppose a 75-ohm antenna is attached to 75-ohm coaxial cable and the cable is terminated into a 300-ohm FM receiver. Then, it is noticed that some of the multiplex signals are being received with poor separation.

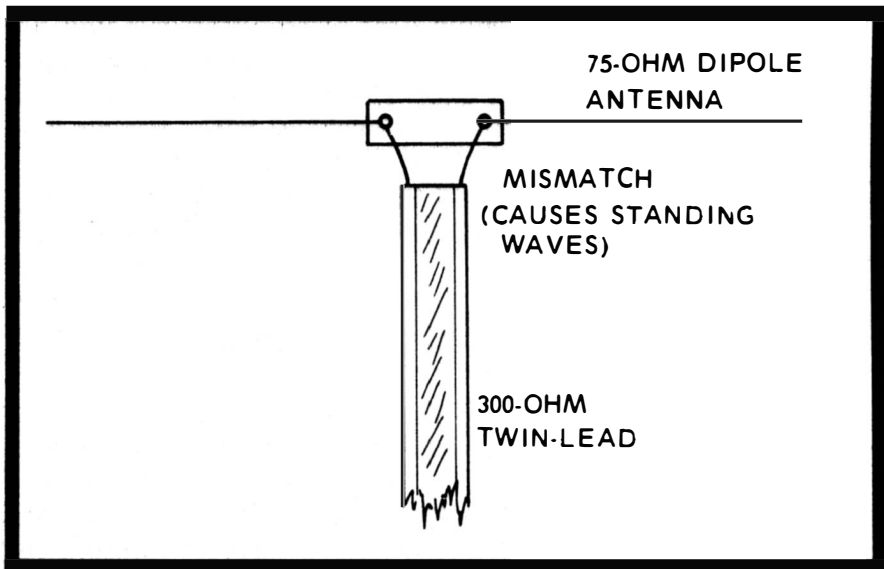

Fig. 52. Standing waves are caused by impedance "bumps" in mismatched antenna components.

The answer to the problem could be the installation of a impedance-matching transformer at the receiver. This eliminates the line-to-receiver 4-to-1 mismatch and could produce enough signal to bring the multiplex signal strength high enough for satisfactory separation.

#### **No. 51: UHF, VHF, & FM ANTENNAS ON SAME MAST**

Quite often it is necessary to mount all three—UHF, VHF and FM—antennas on the same mast. It is certainly less expensive and more convenient to do so. A problem arises, though, since the three antennas cannot be mounted to a few wavelengths apart, but each must be within the other's sphere of influence. This produces mutual coupling. The antennas will act as a vertical stack with random directors and reflectors for each other. It is possible to actually sit down with a slide rule and various charts to compute the distances and orientation necessary to obtain maximum reception.

At various distances the antennas will cause improved and reduced reception for individual channels. It is not practical to try and work it out mathematically. It is better to use a field strength meter and fix the antennas at specific spots indicated by maximum microvolt or db readings.

Install the mast and place the UHF antenna first. Snug it down at the best compromise position for the UHF channels on the meter (Fig. 53). Next, mount the VHF antenna below the UHF and snug it down at the best orientation and distance from the UHF. Recheck the UHF and reposition if necessary.

Mount the FM antenna well below the VHF. Install it at the best position. Then recheck the VHF and the UHF. Find the best compromise position for all the channels. Keep switching back and forth, making touchup adjustments. Then tighten down.

#### **No. 52: TV MASTER AMPLIFIERS OUTPUT TESTS**

When more than several TVs are fed from an antenna, a special trouble crops up. It's called cross modulation and occurs as a TVI effect called "windshield wiper." The channel affected is the victim of another stronger channel. The stronger channel that is causing the problem is being received beautifully. However, it is overloading the amplifier and spilling video signal into the weaker channel.

The amplifier has specifications showing how much input in microvolts it can handle without overloading. A field strength meter is attached to the antenna lead-in in place of the amplifier (Fig. 54). Then, microvolt readings are taken on each of the channels. These readings are compared to the amplifier's input specifications.

It will usually be found that one or more of the clear channels is being received by the antenna at a higher strength than the amplifier is designed to process. These excessive signals must be weakened. This can be done by changing the orientation or by attaching attenuator pads between the antenna and the amplifier. If there is a gain control on the amplifier, it can be lowered to a more satisfactory level.

The FSM is left in the line until the signals are balanced. It is best to have the signal strengths of all channels as nearly equal as possible. A level just 6 db more than another signal level can cause cross modulation.

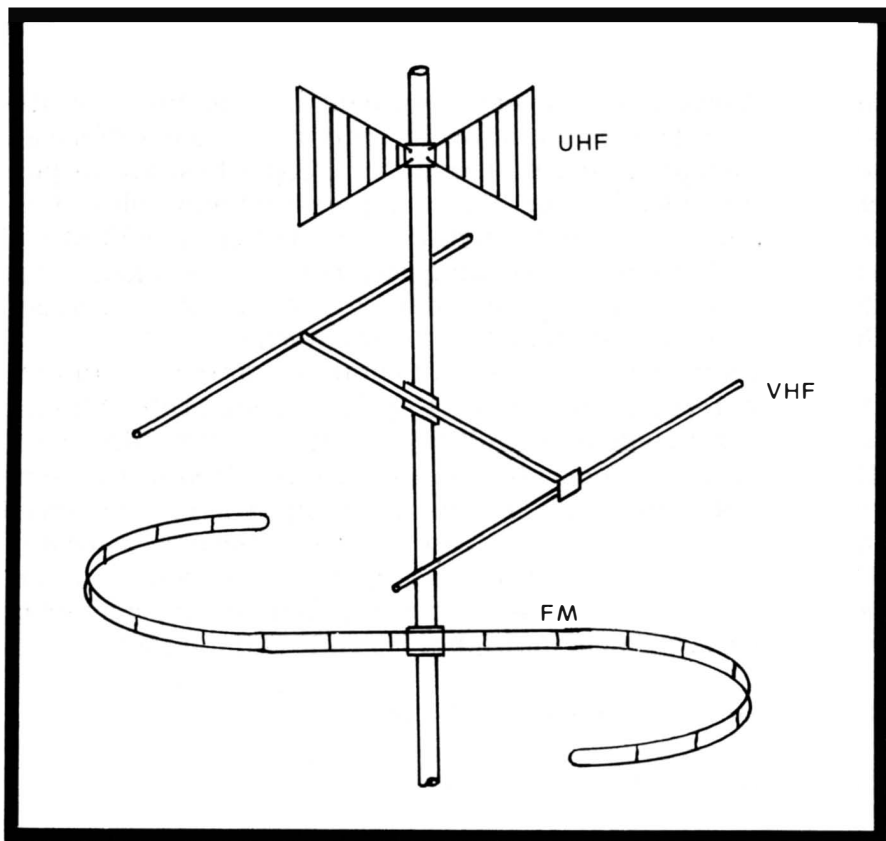

Fig. 53. If you must install UHF, VHF and FM antennas on one mast, place the UHF on top and FM on the bottom.

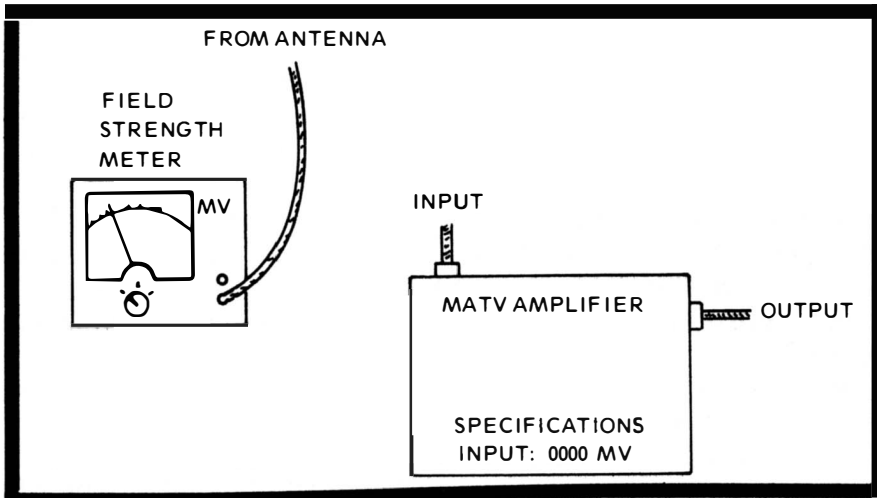

Fig. 54. By comparing the input of an MATV system to its rated output, good quality pictures are obtained.

### No. 53: IMPEDANCE MATCHING & CONVERSION

In deep fringe areas, every microvolt is valuable. The difference of a hundred microvolts can mean the difference between reception and no reception. People hesitate to purchase large color TVs or FM multiplex systems unless they are assured they will get satisfactory reception. The FSM will give accurate microvolt reading results if care is taken to use the correct impedance matched lead-in, or if it's not correct, that the lead-in is matched by a transformer.

When a transformer is used to match a 300-ohm lead-in to the 75-ohm terminal of a FSM (Fig. 55), a rough rule of thumb used by technicians is to multiply the microvolt reading by 2. This is far from accurate, because as the frequency being received becomes higher, the standing waves developed become more numerous and losses become greater. Therefore, a more accurate multiplier is needed. It is not necessary that the multiplier be changed for every channel or FM station. A group of multipliers is quite satisfactory:

TV Channels 2 through 6: Multiply by 1.1

FM stations: Multiply by 1.1

TV Channels 7 through 13: Multiply by 1.4

TV Channels 14 through 83: Multiply by 3.0

When you do multiply you are changing the microvolt reading with the losses to the reading of the signal that will actually be feeding the receiver.

#### No. 54: UHF CONSIDERATIONS

UHF is tricky. Good reception can be attained in one house, while next door it's non-existent. If UHF is going to be tough, it's a good idea to add a special UHF antenna to the one being installed. Also, when UHF reception is difficult, care must be taken that all lead-ins are terminated properly, all connections are snug and the UHF lead is well away from any metal objects or metal surfaces.

No matter how hard you try, though, UHF signals encounter one serious problem—resistance in the line, which produces mismatches and signal loss. This can be helped considerably by attaching “stubs” either at the receiver (Fig. 56) or on the antenna. Attaching a stub is a hit-and-miss affair. At these frequencies a closed stub works best.

The FSM is attached to the lead-in and a reading taken. Then the “stubbing” can begin. According to a particular channel frequency, a certain size stub works best. Due to the

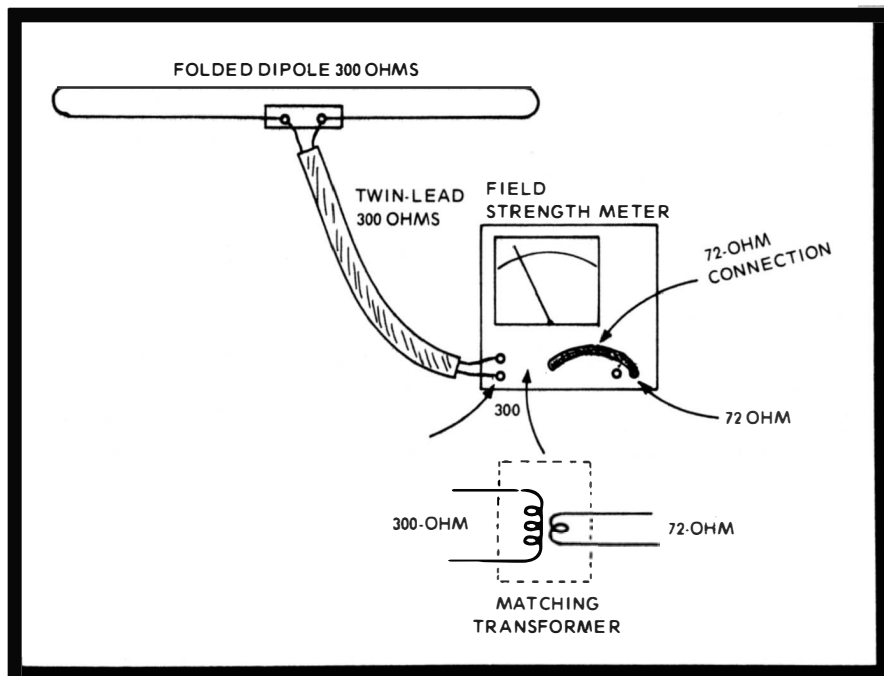

Fig. 55. To insure accurate microvolt readings, the antenna lead-in must be matched to the meter input.

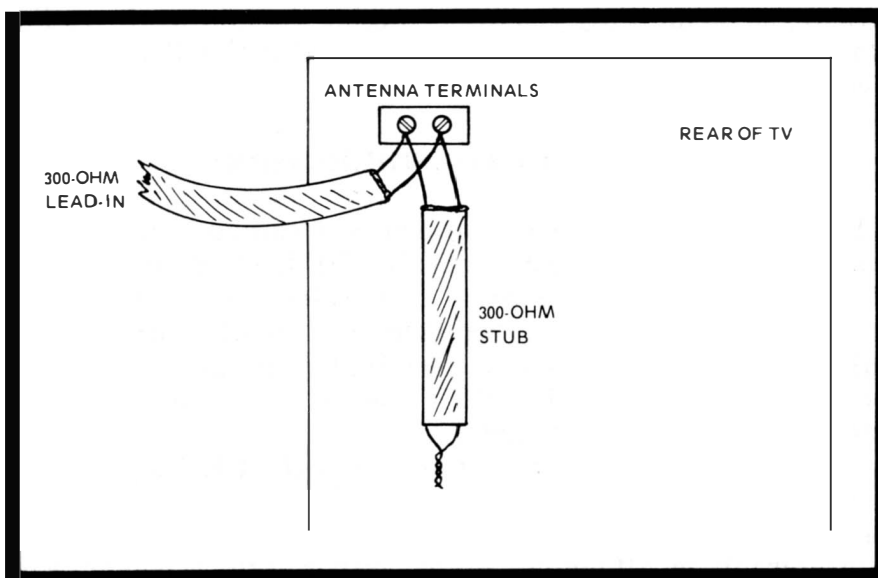

Fig. 56. A piece of 300-ohm twin-lead at TV frequencies is actually a complete capacitance-inductance tuned circuit (called a "stub").

multiplicity of stations and stubs, the easiest way is to begin shorting out stubs and watching the meter at a particular tuned frequency. When a stub is shorted out and produces the maximum microvolt reading, you have the correct tuned stub. In some cases, more than one stub is needed. You can attach one at the antenna and the other at the receiver.

### No. 55: TVI LOCATION PINPOINTING

Most TVI comes from various sources, and quite frequently the perpetrator of the disturbance is completely unaware of it. Once the TVI producer is apprised of the fact that he is causing it, he will take care of it. If he won't, the FCC will make sure he does. Of course, the job is locating the unwanted transmission. This can be done with a good field strength meter and a set of rabbit ears.

Take a map of the area and lay it flat (Fig. 57). With a compass orient the map to line up with the actual north-south position. Attach the map to the flat surface. Then, during the TVI, tune it in. If it's on Channel 3, tune the FSM to Channel 3. The Sencore FS134 has a speaker output. You can hear the interference as you tune it in. Quite often you'll hear voice modulation and call letters which simplifies the sleuthing.



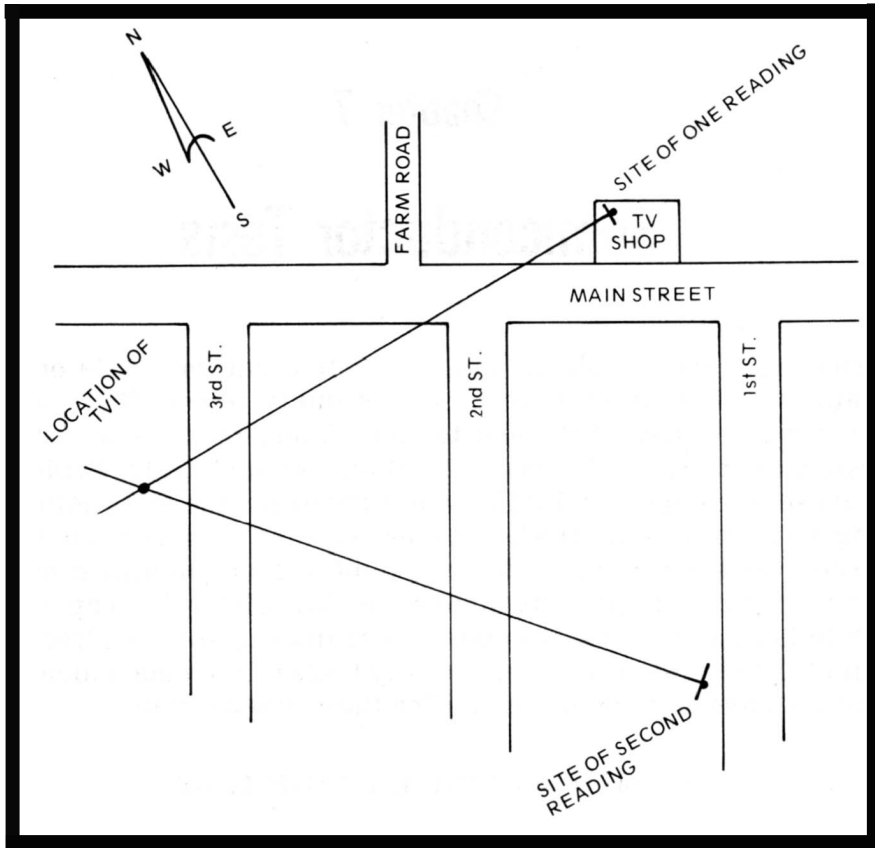

Fig. 57. Triangulation of a TVI source leads to its identification and then to the eventual riddance of it.

When its a non-voice type, take the rabbit ears and rotate it until you get the peak amount of signal as indicated on the FSM in microvolts. Note the broadside direction of the TVI and draw a line across the map in the exact compass direction. Then go to another location and take another broadside directional reading. Draw a second line on the map. By triangulation you can pinpoint the actual location of the unwanted transmission. Go to that location and see if the microvolt readings increase. Follow the peak of the readings and you'll locate the culprit. Then personal relations and electronic trapping can eliminate it.

## Chapter 7

# Semiconductor Tests

Aside from the simple go-no go tests that can be made on a transistor with an ohmmeter or continuity tester, there are other parameters that need testing. Many of the transistor testers on the market today are suitable for such tests. Typical of these is the Sencore TF 151, which performs the tests both in and out of the circuit. It's best to test working transistors in the circuit, unless the transistor is a plug-in type. Removal of a transistor by unsoldering places the transistor in jeopardy while heat and stress is applied. A transistor that is already out of the circuit, of course, is easily tested. It's a good idea to test all transistors before installing them into a circuit.

### No. 56: HANDLING DAMAGE TEST

Transistors are fragile devices, especially the MOSFETs and IGFETs. It's good to know how much damage you have caused to a transistor by simply taking it out of its box and soldering it into a circuit. No matter how careful you are, some damage will occur. Perhaps shortening the leads with a pair of cutters, some static charges from your body or heat from the soldering iron will do it.

The two most important transistor tests are the amount of amplification and the amount of leakage. Make a test before the installation and then again after the device is in the circuit. Notice any differences. Be sure to take any shunt resistances into consideration when reading leakage. The difference between the two readings is the handling damage. If the damage is too great, try installing another transistor. When the damage is slight or almost not recognizable, you have successfully installed the transistor.

### No. 57: CHECKING UNKNOWN TRANSISTOR

Quite often during the repair of electronic circuits, a replacement transistor is needed. In non-critical applications the servicer can quite often get by or confirm a defect by

substituting a transistor that bears no physical resemblance to the original. The only two characteristics that must match in these cases are the type and voltage rating. This type of transistor might be available in loose lots of transistors. You can test the transistor quickly and determine its type. You cannot substitute an NPN for a PNP and vice versa, though.

It's a good idea to get yourself set up for this test immediately before the need for the test arrives. If you are set up, the test can be accomplished in seconds.

A transistor responds to an ohmmeter exactly as two diodes do—back to back. To check a diode with an ohmmeter, connect the test probes across the diode, take a resistance reading and then reverse the test leads, and take a second reading. A good solid-state diode (we are discussing small germanium and silicon diodes, not the large selenium types) will read a low resistance in one direction and a high resistance when the leads are reversed. The ratio between the two readings should be 10 to 1 or better. The better the ratio, the more efficient the diode.

Actually, what you are doing is injecting a small battery voltage through the diode and a meter (Fig. 58). When the battery's positive side is attached to the anode (or the minus on the diode) and its negative end attached to the cathode (or the plus on the diode), some of the DC will flow through the diode. This causes a large needle deflection through the meter which denotes a low resistance and, as it's called, a forward bias.

To sum up, forward bias shows up on the ohmmeter as a low resistance. The battery, not necessarily the leads of the meter, is attached with the plus of the battery to the minus or anode of the diode. The battery's negative lead is attached to the cathode or plus of the diode. When the ohmmeter leads are reversed, the positive end of the battery is attached to the cathode or plus of the diode and the negative end of the battery is attached to the anode or minus of the diode. The ohmmeter reads a high resistance (very little scale deflection) because practically no DC can flow from the anode to cathode. This is called reverse bias.

Reverse bias shows up on the ohmmeter as a high resistance. The battery is attached with the plus of the battery on the plus or cathode of the diode. The minus of the battery is attached to the minus or anode of the diode.

Confusing? You bet, but you must memorize that the plus and minus signs on the diode are opposite to the polarity of the voltage that is attached for forward bias or conduction. Also, you must keep in mind that the positive and negative leads on

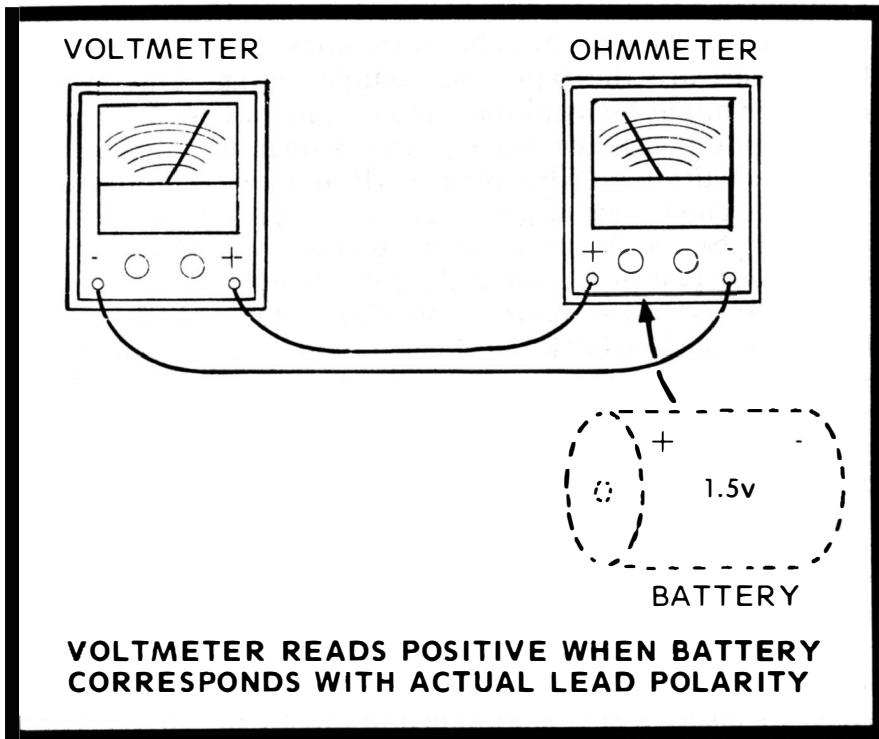

Fig. 58. You can tell battery polarity with your ohmmeter by taking a voltage reading at the probes.

the meter do not necessarily correspond with the battery polarity. The ohmmeter battery could be attached with the negative terminal to the plus lead and vice versa.

The next thing is that a transistor is thought of as two diodes back to back. Therefore, as you look at the schematic of a transistor and notice the bar and triangle, you see there is only one such set (Fig. 59). There are still two diodes in that transistor. The other bar and triangle are not shown. Get into the habit of thinking of a transistor as if the other bar and triangle are actually drawn on the schematic. The second is attached with either the two bars common or the two triangles common.

If the two bars are common, the transistor is a PNP. When the two triangles are common, the transistor is an NPN. Forward bias is a state when current flows from the bar to the triangle. Reverse bias is when DC tries to flow from the triangle to the bar but it can't.

Take a known good PNP and attach your ohmmeter negative lead to the junction between the two diodes or, as it's

called, the base. Attach the positive lead first to the end of the top diode and then to the end of the bottom diode.

If a low resistance occurs at both ends, you have created forward bias. At a convenient spot, such as on the wall over the service bench, mark a schematic drawing of the PNP transistor with the negative lead going to the junction, the positive lead going to the ends. Then write forward bias, low resistance. That's it. Whenever you get an unknown transistor, attach your ohmmeter to it in that way. If a low resistance is measured, it's a PNP. Should a high resistance reading be present, it's an NPN, assuming these are good transistors, of course.

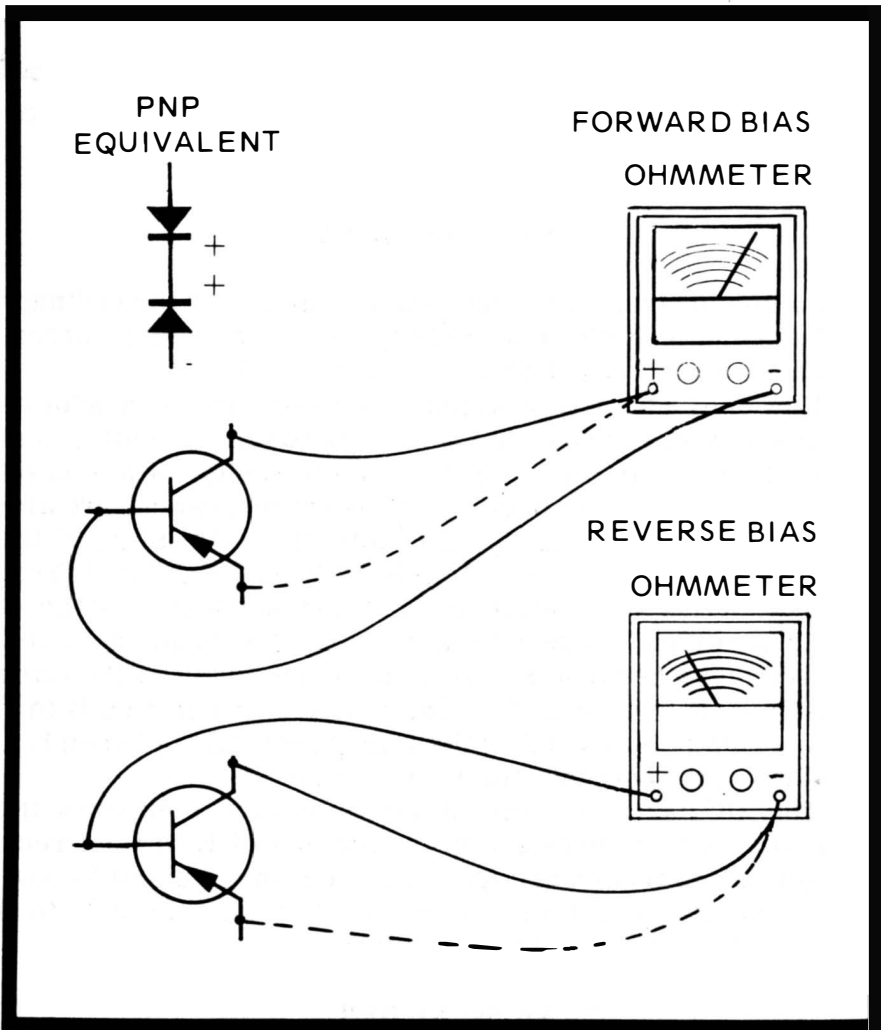

Fig. 59. A go-no go transistor test is quickly made with an ohmmeter considering a transistor as two diodes.

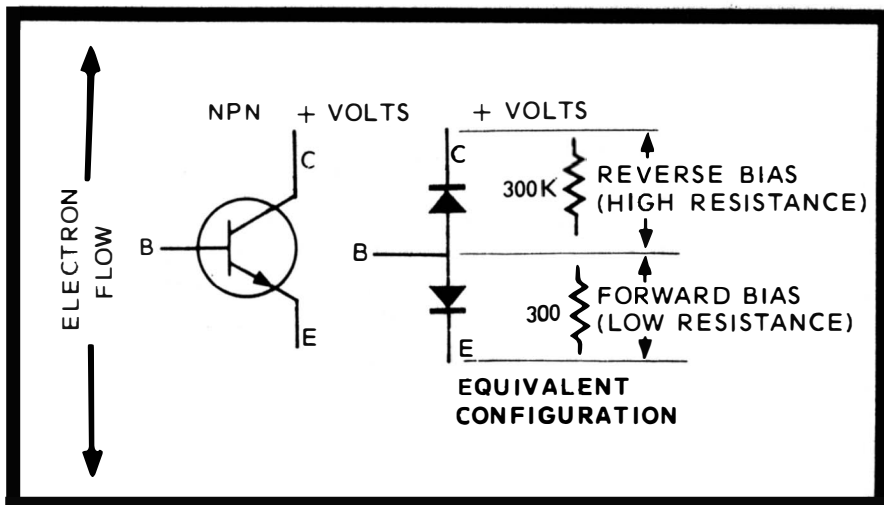

Fig. 60. The bipolar transistor has characteristics similar to two diodes connected back to back.

#### No. 58: DC BETA

With a bipolar transistor (just another name for the ordinary garden variety NPN and PNP types) beta is the current amplification factor and can be either DC or AC.

How does a transistor amplify? Consider the transistor as two diodes back to back. One diode is between the emitter and base, while the other diode is between the collector and base. Since they are back to back, the forward resistances are also back to back and going opposite directions. In an NPN the forward or low resistance is from E to B and from C to B. That means E to B is a low resistance as B to C is a high resistance.

As a current travels from E to C, it encounters a few hundred ohms between E and B and a few hundred thousand ohms from B to C (Fig. 60). The power gain between B to C becomes many times higher than the power gain between E to B as long as the current remains the same.

The DC beta, or current amplification, compares the amount of E to B current with the amount of E to C current. The small E to B current causes a large E to C current to flow. The ratio gives the beta. For instance, if one ma of E to B causes 100 ma of E to C, the beta is 100.

#### No. 59: AC BETA

At low frequencies the AC beta and DC beta are almost the same. Any differences start to occur as the frequency is raised

and other factors enter the picture, such as distributed capacitance, resistance and barriers between N and P sections.

AC beta is considered a more valid test than DC, since it is really a dynamic test while the DC is a static one. AC beta is the ratio of collector current change divided by base current change. The collector voltage is held constant during the test.

The AC beta range can double from one frequency to another. Use any readings on a general basis rather than exact when comparing them to a transistor test manual listing. The listing shows a typical mid-frequency range value.

### **No. 60: AC BETA TEST SETUP**

A bipolar transistor can be tested either in or out of the circuit. The equipment being tested during an in-circuit test is turned off. Any voltages needed for the test are supplied by the transistor tester. Typically, as in the Sencore TF151, there are three test leads for the bipolar transistor. One for each of E, B and C. In this case red for the collector, yellow for the base and black for the emitter. An NPN-PNP switch places a positive bias voltage on NPN collectors and a negative bias voltage on PNP collectors. A function switch chooses different modes of operation. Lo-Power, Hi-Power and Special RF.

Most transistors are Lo-Power types. They have less than a watt of output. Any transistors that can provide a watt or more are tested in the Hi-Power position. Critical RF transistors that saturate easily are tested in the Special RF position. Should you test one of these special ones in the Lo-Power position, you'll find that under saturation the beta reading becomes less than one. If that happens, try the Special RF position.

Once the hookup and switches are set, the needle will rise to a set position. Adjust the Beta CAL knob until the needle is on the Beta CAL line. That calibrates the needle so it will read beta directly. The gain button is pushed and the AC beta is read directly. Multiply the reading by the range switch setting: X1, X10, or X100. Most readings are made at X10.

### **No. 61: OPEN TRANSISTOR TEST**

When either the emitter, case or collector opens, the transistor will not amplify (Fig. 61). It is hard to determine which junction has actually broken since they all act alike. When the transistor is in a circuit, Beta calibration is possible due to all

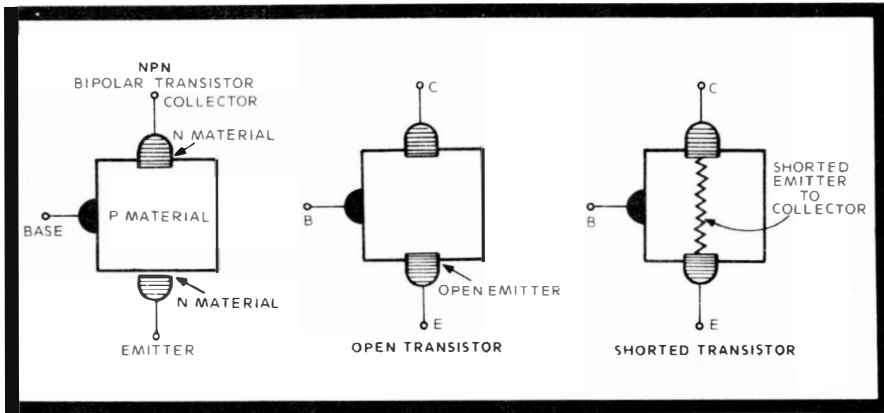

Fig. 61. A transistor breaks down by opening, shorting or leaking. A transistor tester quickly reveals the condition.

the shunt components that form a resistive network around the suspect transistor. However, when you press the gain button no beta reading occurs. If you should test an open transistor out of a circuit, you can't even get the Beta CAL in place. There is infinite resistance around the broken transistor.

#### **No. 62: E TO C DEAD SHORT TEST**

A dead short from the emitter to collector prevents beta calibration. In or out of the circuit, the dead short shunts out all other components and prevents the Beta CAL from registering anything.

#### **No. 63: E TO C HIGH-RESISTANCE SHORT TEST FOR BETA**

When there is a high resistance short from emitter to collector, some beta might be read on the meter, but it will be incorrect. According to the actual resistance of the short, the beta will read near correct for a short in the megohm range to practically no beta in the kilohm range.

#### **No. 64: E TO C LOW-RESISTANCE SHORT TEST FOR BETA**

When there is a low-resistance short, under 10K, the meter might calibrate OK. However, when the gain button is pushed, the meter needle will vibrate badly.



### **No. 65: B TO C SHORT TEST FOR BETA**

Unlike the E to C short where the entire transistor is defective. since E and C are at either end of the transistor, a B to C short leaves the E to B intact. E to B still demonstrates the front-to-back resistance ratio of a diode. With B to C shorted, it's as if you were testing a diode using a transistor tester with the B to C leads shorted as in a dead short, or with a resistance as in a high resistance short.

The tester will calibrate, due to the resistance of the good section of the transistor, but it won't read any gain since the transistor has lost its amplification power. When the gain button is pushed, nothing happens to the needle.

### **No. 66: B TO E SHORT TEST FOR BETA**

When the base-to-emitter junction shorts, the base to collector junction is still good. The B to C junction acts like a diode with the B to E leads shorted together. The transistor tester will calibrate, but the actual test makes the needle swing all the way to the left or infinity and the needle vibrates.

### **No. 67: MAKE-SURE TEST**

It is useful to know what your transistor tester does when a particular junction is shorted, open, has a high-resistance or low-resistance short. Even though the transistor tester gives a positive indication of a defect in a specific transistor, you are still not sure if the transistor is being tested in a circuit. You must perform a "make sure test" once you pinpoint a suspect in a circuit, especially if you find that there is another transistor, diode, low-value resistor or capacitor across either the EB or BC junction.

Usually, the make sure test is easy. Lift the base connection from the circuit and retest the transistor. If the transistor does not read bad, it is not bad. The reading you received in the circuit was due to one of the shunt components and it probably wasn't defective either.

Should the tester still indicate that the transistor is defective, then you are ready for the final make-sure test. Remove the transistor from the circuit and test once more. If it reads defective, it is bad. Be sure to test all the components in shunt with the transistor before installing a new one.

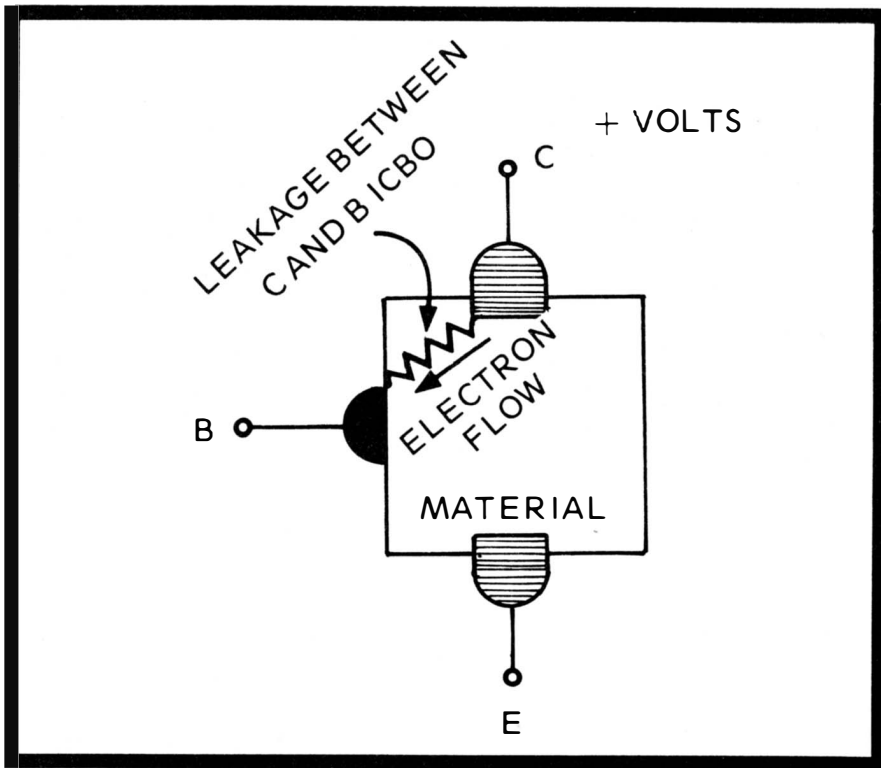

Fig. 62. ICBO leakage is the amount of electron flow that travels during reverse bias from C to B.

Chances are better than 50-50 that a shunt component is also defective and has caused the defect in the transistor.

#### No. 68: TRANSISTOR LEAKAGE TEST

Bipolar transistor leakage is called ICBO (Fig. 62). The I is current that is leaking through the collector C to base B. The O means there is nothing else in consideration. There is always some tiny leakage between C and B. It is only when it becomes more than is normal that the leakage becomes a defect. In other words, all bipolar transistors have some ICBO, however minute.

Unfortunately, an accurate ICBO test cannot be performed in-circuit, unless there is infinite resistance in shunt with the transistor. This means across EB and EC as well as CB. Once out of the circuit the test is simple and almost like an ohmmeter test. The three test leads are attached to E, B and C. The function switch is set to leakage ICBO. The type switch is set on NPN or PNP according to the transistor under test.

This sets up the correct polarity voltage for the leakage test. The amount of leakage is read directly in microamps.

Considerably more than normal leakage means a poor or hopelessly defective transistor. If there should be less leakage than normal, it usually means an exceptionally good transistor, except if the circuit is designed with a need for the ICBO. Then, less leakage could mean a more normal transistor will have to be used.

### **Switched Test Leads**

Transistors are tiny objects but they can cause all kinds of problems, especially as you test in-circuit and sometimes out of circuit. A common occurrence is getting the test leads interchanged. The multitude of physical configurations compounds the problems. It is useful to know what happens when the leads become interchanged.

#### **No. 69: SWITCHED LEADS, COLLECTOR AND EMITTER**

Quite often when this happens it goes unnoticed and there is no harm done. Many transistors are the actual equivalent of two diodes back to back. When they are, the collector and emitter are almost identical and, in fact, could be attached that way in an actual circuit.

Other times, there is a considerable difference between the collector and emitter pieces of N or P material. When there is such a difference, the tester will calibrate fine, but when the gain button is pressed, a very low beta figure is produced. When the beta is ridiculously low, be sure to double check that the collector and emitter leads are not switched.

#### **No. 70: SWITCHED LEADS, COLLECTOR AND BASE**

When the collector and base leads are switched, you accidentally are placing the collector B plus or B minus voltage on the base. At the same time the base bias voltage is placed on the collector. Without the collector voltage the transistor is almost turned off. The meter will calibrate all right, but the beta will be very low and incorrect. When beta is so low, double check the leads before pronouncing the transistor defective.

## No. 71: SWITCHED LEADS, EMITTER AND BASE

When the emitter and base leads are switched, you have put the emitter voltage on the base and the base bias on the emitter. This reverse bias on the EB junction cuts off the entire transistor.

If you should begin testing and at the same time switch the type to its opposite polarity, you will have compensated for the switched leads with the type switch. The transistor then is forward biased once more and some E to B current will flow. However, with the type switch in the wrong polarity position, the wrong polarity voltage is on the collector. No E-to-C current will flow, even with the forward biased E-to-B junction.

With the correct polarity on the type switch, the meter will not calibrate, nor will any gain be shown when the gain button is pressed. With the wrong polarity on the type switch the meter will calibrate, but no gain is shown as the gain button is pressed. When these sets of circumstances occur, be sure to double check the base-to-emitter leads for switching.

## Chapter 8

# Testing FETS

The field-effect transistor requires as much new thinking when comparing it to a bipolar transistor as is required when the bipolar is compared to the vacuum tube. The FET combines the advantages of the bipolar transistor and the vacuum tube. The FET has no heaters and thus requires no warmup time. The FET is tiny in size and consumes little power. Yet it is a voltage-operated device like a vacuum tube, rather than a current device like the bipolar transistor. It has a high input impedance like a tube, not low like the bipolar. Therefore, an FET must be tested like a vacuum tube. While the bipolar transistor is tested in terms of beta, which is current, the FET is measured in terms of  $G_m$  or micromhos.

There is no emitter, base or collector in an FET. The emitter is the source, the base the gate and the collector a drain. The source, gate and drain compare more closely to the cathode, control and plate of a tube than the emitter, base and collector.

There are NPN and PNP types, but they are called different names. The PNP is called an **N-channel** (Fig. 63), taking its name from the center piece of semiconductor material. The NPN is called **P-channel** (Fig. 64), taking its name also from the center piece of material.

The FET is built slightly different than the bipolar transistor. For instance, in an N-channel FET, there is a substrate of P material. The substrate takes the shape of a deep dish. In the deep dish is another dish of N material. Then in the recess of the N material is a plug of P material. The N material forms a channel between the substrate and plug of P material.

A lead is attached to one side of the N material. It is called the source. A second is attached to the other side of the N material. It is called the drain. If you apply a positive voltage to the drain and ground the source, current will flow from source to drain just like current can flow from a cathode to plate.

A third lead is attached to the plug of P material. It is called the gate and more specifically is called the **top gate**. A

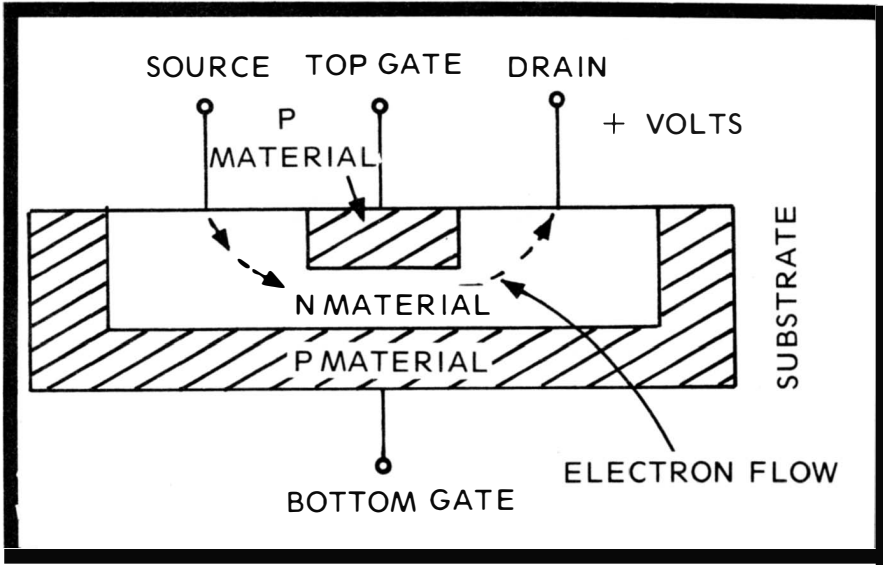

Fig. 63. In an N-channel FET, electron flow is from source (S) to drain (D) and is affected by the gate (G).

fourth lead is attached to substrate. As expected, it is called the **bottom gate**.

While current is flowing from the source to the drain, if you apply a negative voltage to the top and bottom gate, you will narrow the channel and restrict the current flow. Should

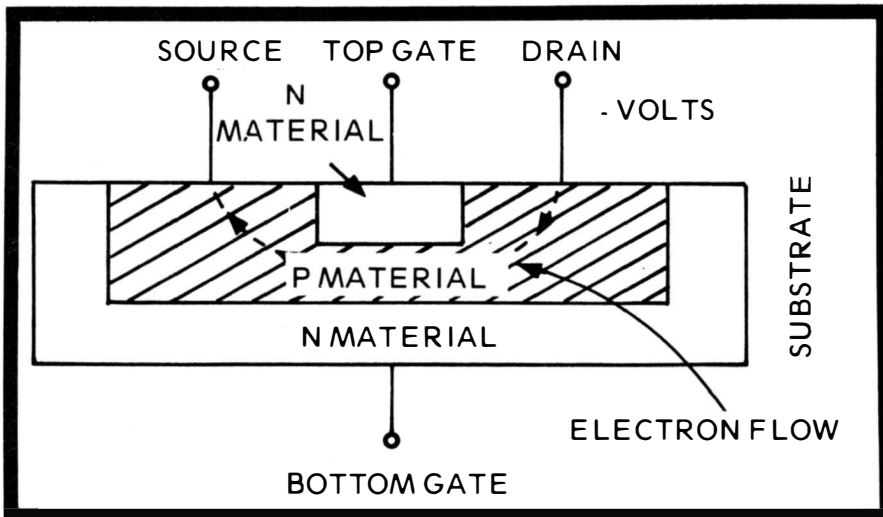

Fig. 64. In a P-channel FET, the electron flow is from drain to source. The gate serves as a valve.

you vary the gate bias voltage with a signal, the channel will narrow and spread in accordance to the bias. In effect, you are modulating an electron stream in the channel just as a control grid modulates an electron stream in a cathode-to-plate flow in a vacuum tube. Amplification is the result. The small bias voltage causes a large drain current change. If the FET is a P-channel device, the source and drain polarities are reversed and the current flows the other way. However, the bias voltage is still negative and the gates narrow the channel to perform the amplification.

### **Schematic Representation**

The FET just described is represented by a schematic symbol closely resembling a diode, except that there are three plate-type leads coming off. It is not at all like a diode so discard the similarity. The cathode-like part is the gate connection. The plate-like part is the channel. The top lead is the drain and the bottom lead is the source. The connections are appropriately lettered G, D and S. They should become as familiar as the bipolar E, B and C.

If you remember that in a PNP the arrowhead is pointed at the base, designating the base material which is N, then when you see an arrowhead in an FET pointed at the channel, it too designates the channel material, in this case, N. In a P-channel FET the arrowhead points away from the channel, meaning P material, similar to an NPN bipolar that has a base of P material.

The FET symbol just described has a solid channel line. This shows that current is always flowing through the channel. This always on channel is opposite to a normal off channel which is indicated by a broken channel line. This brings us to more terminology.

### **Depletion and Enhancement Modes**

When the channel line is solid and thus always on, the FET is called a **depletion type** (Fig. 65). If the channel line is broken into three sections resembling three little plates, the channel is normally off and is called an **enhancement type** (Fig. 66). There are basically four types of ordinary FETs. The depletion N-channel, enhancement N-channel, depletion P-channel and enhancement P-channel.

Don't let the names throw you; the names are more complicated than the function. To recap, there is a current flowing in the channel, one way for the N-channel and the

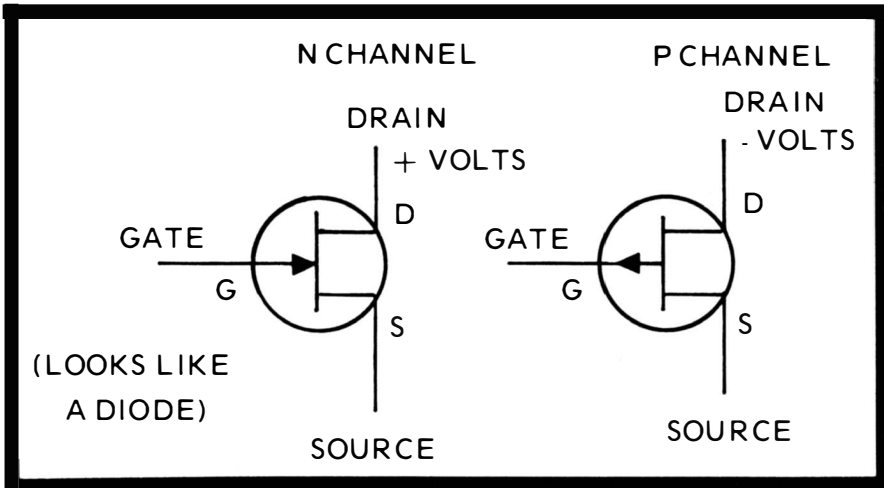

Fig. 65. Depletion-type FET schematic representation. The arrow points at N and away from P.

other way for the P-channel. A negative bias tends to “deplete” the charge and by doing that retards the amount of current. On the other hand, an enhancement type works something like a bipolar transistor. There is no current flowing in the channel. Current does not flow until a positive voltage is applied to the gate, which enhances the charge and the forward type bias, causing the current to flow in accordance to the level of the forward bias. A signal that is modulating the forward bias will modulate the current it causes to flow in the channel.

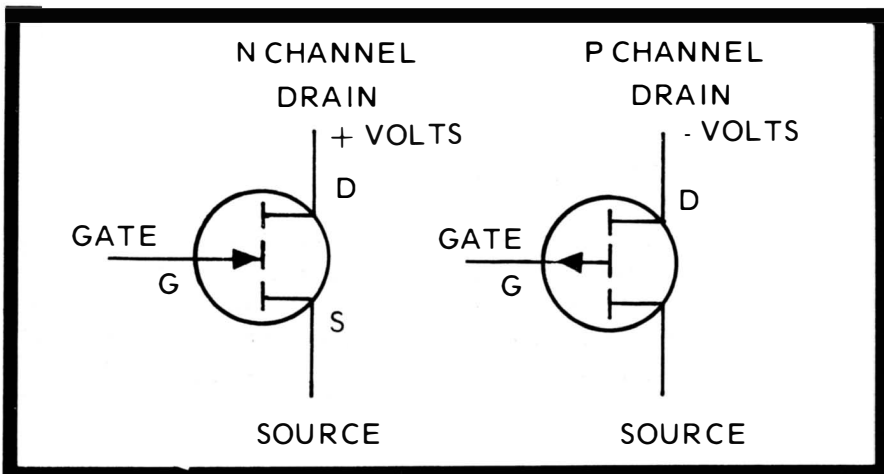

Fig. 66. An enhancement-type FET has a broken channel line, but has the arrows point like a depletion type.



There also is a depletion-enhancement type FET. In these types, a negative gate voltage will deplete the channel current or a positive voltage will enhance the channel current.

### JFETs, IGFETs and MOSFETs

The JFET or junction FET is so named because the junctions between the N and P materials are the same as a junction bipolar transistor. They physically touch each other and form electrostatic barriers between the sections (Fig. 67). The barriers have a small amount of capacitance that varies with the voltage impressed as the barriers are slightly changed.

The IGFET is so called because the gate is insulated from the rest of the device by a thin layer of dielectric material such as glass (silicon dioxide). Therefore, this is not a PN junction between the gate and the FET, thus the name IGFET, insulated gate FET (Fig. 68).

The MOSFET is just another name for an IGFET, but quite often it has more than one gate, typically dual gates (Figs. 69 and 70). The name comes from the dielectric material, metal oxide semiconductor. The gates are made of metal and are insulated from the FET by a silicon dioxide piece of insulation. They are all FETs, however.

### No. 72: TESTING FETs FOR $G_m$ (HOOKUP)

Whether the field-effect transistor is a JFET (junction FET) or an IGFET-MOSFET (insulated gate FET), the  $G_m$  can be

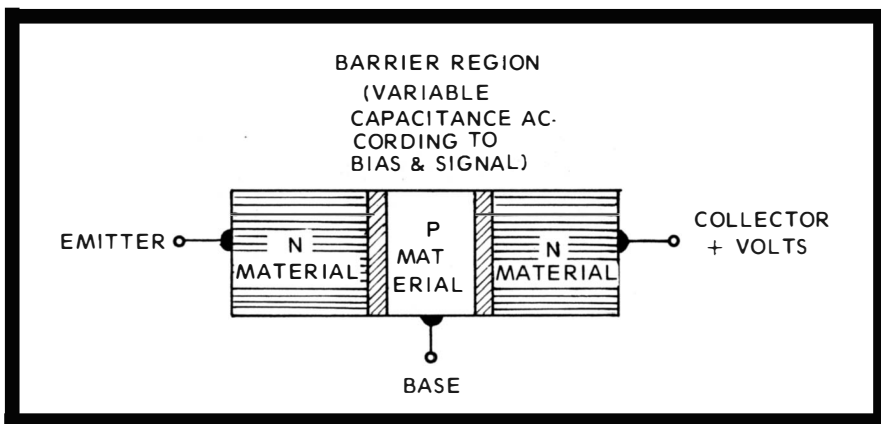

Fig. 67. A bipolar transistor has a depletion region or barrier region between the material junctions.

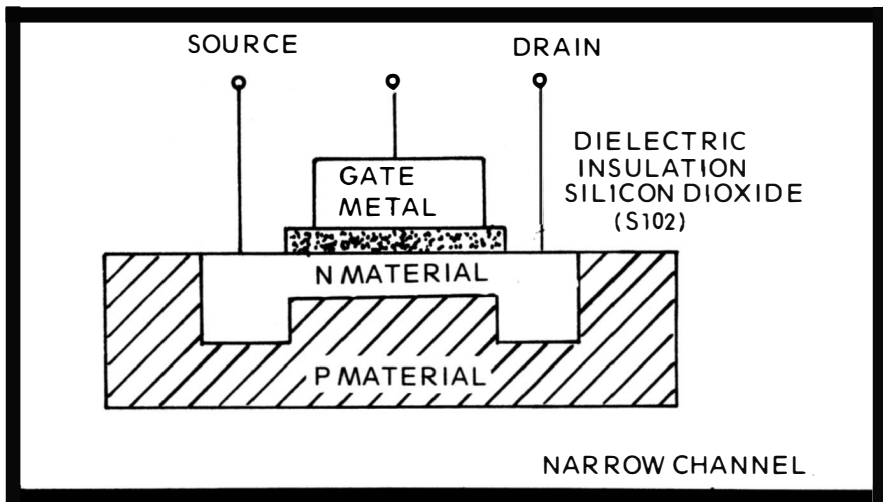

Fig. 68. An insulated gate FET (IGFET) has a narrow channel and the gate is separated by a dielectric.

easily tested with a transistor tester such as the Sencore TF151. The tests are made in or out of the circuit. If the FET has more than one gate, each gate is tested as if it were an individual transistor.

Remembering that the names of the FET connections are the source, the gate and the drain (there is no E, B or C as in a bipolar transistor), notice the connections. The black lead that went to the emitter now is attached to the source. The yellow lead that went to the base now goes to the gate. The red lead that went to the collector now goes to the drain. The analogy is borne out exactly by the tester itself.

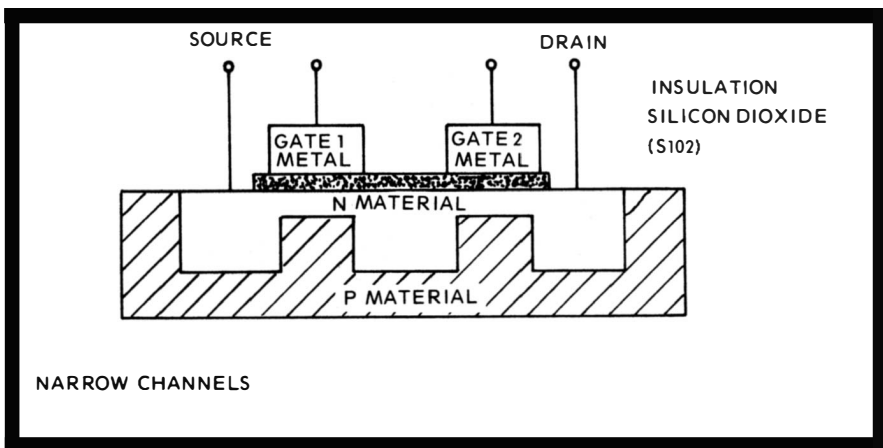

Fig. 69. A metal oxide semiconductor FET (MOSFET) is so named because of the oxide dielectric insulation.

**No. 73: IGFET TESTING 2ND GATE  
FOR  $G_m$  (HOOKUP)**

There is a separate lead for the second gate in an insulated gate on the Sencore TF151. It is blue and is attached to the second gate during the initial hookup. After the first gate is tested, the junction switch is then set on the second gate position. The same test is then repeated for the second gate.

**No. 74: JFET TESTING 2ND GATE  
FOR  $G_m$  (HOOKUP)**

In a JFET, forget the second gate test. It is not applicable. Simply short the two gates together and attach the yellow gate test lead to both the JFET leads. Test the JFET dual gate as if it were a single gate.

**No. 75: DEPLETION MODE BIAS  
TEST (HOOKUP)**

The different types of FETs result in much confusion in determining appropriate test hookups. In a tube tester, there are so many different tubes that each is listed on a chart or in a book and you simply turn switches according to numbers. In

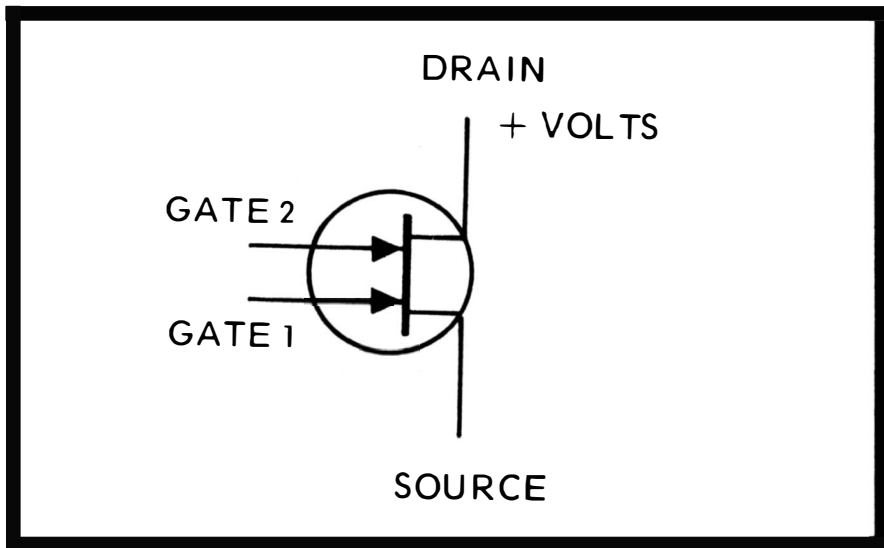

Fig. 70. The schematic diagram of a dual-gate MOSFET, N-channel type.

the transistor tester there are only a few tests, yet at the present time they are much more confusing than a tube tester.

One of the confusions is based on whether the transistor is a depletion or enhancement type. Yes, the settings are listed in the reference book with the tester, but on many occasions the listing cannot be found easily. It's much better if you can determine the settings from the transistor and its schematic. On depletion type transistors, where a reverse bias is applied to the gate, the FET bias switch is placed on normal. This could also be construed as reverse, or negative.

#### **No. 76 : ENHANCEMENT MODE BIAS TEST (HOOKUP)**

In the enhancement type FET, the actual transistor must be (in most cases) an insulated gate type. Depletion types can be either JFETs or IGFETs. This is because depletion types, when they are JFETs, can use only a reverse bias, since a forward bias will cause ruining conduction between the gate and the channel, much like the vacuum tube control grid that draws too much current.

The enhancement type, since it is an IGFET, can have a forward bias. The bias cannot cause gate current to flow due to the layer of dielectric insulation between the gate and the channel. As a result, when you find an enhancement type FET, you can be sure it's an IGFET and you can apply a forward or positive bias. Set the FET bias switch to POS for positive.

#### **No. 77: FET TEST FOR G<sub>m</sub>**

Once you get the leads on the FET properly, set up the function switch and the correct bias polarity, you are ready for the actual G<sub>m</sub> test. Set the F<sub>m</sub> selector on X1 and the type switch on the N- or P-Channel type, whichever it is. The N-channel type arrowhead points to the N channel, while the P-channel type arrowhead points away from the P channel.

Press the gain button and read the G<sub>m</sub> directly in micromhos. If the needle swings too far to the right, reset on X10, reread and multiply the meter reading by 10.

#### **No. 78: SHORT TEST, SOURCE TO DRAIN**

When a short develops from the source to the drain, since they are both simply connections on the opposite ends of a piece of semiconductor material, the material has broken down. It has

changed its composition and become a conductor instead of a semiconductor. The tester needle will vibrate from the large amount of current being drawn through the meter from S to D. If the gain button is pressed, there is no gain registered. The FET keeps pulling the current.

#### **No. 79: SHORT TEST, GATE TO DRAIN**

When a short develops between a gate and the drain, either the barrier in a JFET or the dielectric in an IGFET has shorted. The unit is no longer a transistor but a resistor with three or four connections. The tester needle will vibrate from the current going to the wrong places between the channel and gate. No valid gain reading can be made.

#### **No. 80: SHORT TEST, GATE TO SOURCE**

A short between the gate and source is quite similar to the short between the gate and drain. The channel is shorted to the gate, only at the other end. There will be less tester needle vibration since the drain voltage is not shorted to the gate. The source voltage is.

In some cases, according to the polarity of the channel, the source-gate and drain-gate shorts will appear the same. For instance, a short in a P-channel device between source and gate will appear the same as a short in an N-channel device between the drain and gate.

#### **No. 81: OPEN TEST, GATE DEPLETION TYPE**

When the gate opens, it's as if a vacuum tube has an open control grid. The current through the channel will flow unimpeded by any gate bias voltage. The channel acts like a resistor with current flowing from source to drain. The meter shows erratic movement and cannot be zeroed, since the bias from the tester has no effect on the FET.

#### **No. 82: OPEN TEST, GATE ENHANCEMENT TYPE**

When the gate opens, no forward bias can be applied. No current flows through the channel without the forward bias. Nothing happens with the meter. The needle just stays on zero, no matter what test is performed. The device remains completely passive and is cut off.

### **No. 83: OPEN TEST, SOURCE**

When the source opens in either a depletion or enhancement type FET, the current is cut off and no  $G_m$  can be read. The meter needle simply stays on zero. The device is completely nonconductive. It's like an open cathode in a vacuum tube.

### **No. 84: OPEN TEST, DRAIN**

When the drain opens in either a depletion or enhancement type FET, the current is cut off and no  $G_m$  can be read. When the meter is zeroed, the needle does not move. The device is completely nonconductive. It's like an open plate in a vacuum tube.

### **Incorrect Testing**

Quite often an attempt is made to test a transistor with the leads accidentally interchanged or a switch set on the wrong position. When that happens, false indications are given by the meter. Most technicians are familiar with what happens when a tube tester is accidentally set incorrectly. Following are the results of FET tests that are accidentally set up wrong.

### **No. 85: JFET BIAS POSITIVE INSTEAD OF NORM**

When a depletion type JFET has a forward bias applied to its gate instead of a reverse bias, current can flow between the gate and the channel. If this happens, it's like a short between the source and the gate or between the drain and the gate. Either no  $G_m$  reading will result or the needle will start vibrating and a very weak  $G_m$  reading will be indicated.

### **No. 86: IGFET BIAS POSITIVE INSTEAD OF NORM**

When a depletion type IGFET has a forward bias applied to the gate (POS setting), nothing happens. The dielectric between the gate and the channel halts any DC current flow just as the dielectric in a blocking capacitor. The meter needle stays on zero and no  $G_m$  reading is recorded.

**No. 87: MOSFET BIAS NORM  
INSTEAD OF POSITIVE**

If an enhancement type MOSFET has a reverse bias applied to its gate, instead of a positive bias, the FET does nothing.

**No. 88: SOURCE AND DRAIN  
LEADS SWITCHED**

Should the source and drain leads become switched in either an N-channel, P-channel or the depletion or enhancement types, you'll never notice the difference during the test. All you are doing is reversing the direction of the current or hole movement. The channel is one piece of either N or P material and can conduct either way. You'll get a Gm reading and it will be accurate.

**No. 89: GATE AND DRAIN LEADS  
SWITCHED JFET N-CHANNEL**

When the gate and drain leads are switched while testing a JFET N-channel type, you are placing a normal negative voltage from the gate on the drain and a positive drain voltage on the gate. The N-channel current is reversed and goes from drain to source instead of the other way. The positive gate voltage forward biases the drain-to-gate junction and the drain-to-source current flows into the gate. As a result the meter reads no Gm.

**No. 90: GATE AND SOURCE LEADS  
SWITCHED, JFET N-CHANNEL**

When the G and S leads are switched, the negative gate voltage is placed on the source and the source chassis ground is placed on the gate. This forward biases the source-to-gate junction. All of the source current flows into the gate instead of to the drain. The source and gate act like an ordinary forward biased solid-state diode. The meter will not read any Gm at all. It's as if the source-to-gate junction were shorted. The meter zeros OK, but there is no needle movement.

**No. 91: GATE AND DRAIN LEADS SWITCHED,  
IGFET N-CHANNEL DEPLETION TYPE**

When the G and D leads in this test are switched, the positive drain voltage is placed on the gate and the negative gate

voltage on the drain. This causes channel current to flow from drain to source and the positive bias on the gate keeps the channel wide open. No current can flow from the channel to the gate in an insulated gate. As a result, the meter can be zeroed and it will read  $G_m$  accurately, but in a negative direction.

#### **No. 92: GATE AND SOURCE LEADS SWITCHED, IGFET N-CHANNEL DEPLETION TYPE**

Should the G and S leads become switched in this type, the negative gate voltage is placed on the source and the chassis ground source is placed on the gate. This places a forward bias on the source-to-gate, but no junction current can flow in an insulated gate.

The current flows well from source to drain. The biases are the same as in an enhancement type FET. As a result, the channel current flows wide open and the  $G_m$  reading can be read, although it is not at all accurate.

#### **No. 93: GATE LEAKAGE, JFET**

Gate leakage to the channel is a very important FET parameter. Leakage in an FET is extremely low, normally. Since a JFET is basically a 2-piece transistor (the gate and the channel), a resistance reading from the gate to the source will provide a rough go-no go test.

The third part of the transistor is the substrate and is largely ignored during testing. A JFET has a resistance in the hundreds of megohms between the PN junction of gate and source. Any resistance reading at all on the ordinary shop VTVM is an indication of too much leakage.

Compare any suspicious ohmmeter readings with the same reading on a "known good" JFET of the same type. Be sure to double check any resistance readings you get with the JFET in the circuit with one out of the circuit. A shunt resistance could be causing the suspicious resistance reading.

#### **No. 94: GATE LEAKAGE, IGFET**

While a JFET has a multimegohm reading across the PN junction, an IGFET has a resistance reading in the millions of megohms. The resistance test is identical to a capacitor go-no go resistance test. Any resistance at all on the ordinary shop VTVM means a defective piece of dielectric between the gate and the channel.



### **No. 95: GATE LEAKAGE (IGSS)**

The actual amount of IGSS is very important. It is quite similar to the amount of control grid leakage in a vacuum tube. Too much leakage can badly upset the function of a circuit. It lowers gain considerably and can introduce unwanted biases. Too much IGSS lowers the input impedance of the FET.

IGSS should be tested in all new JFETs, IGFETs and dual-gate FETs before they are put in service. Some circuits can be very critical and, even though an exact replacement is being used, a slightly different amount of gate leakage will upset the circuit.

IGSS means the amount of current in microamps that manages to get from G to S. In a dual-gate FET, the number one gate leakage is designated IG1SS and the leakage of the second gate is called IG2SS. Leakage should be tested with the device out of the circuit, because any amount of shunt resistance, no matter how tiny, can upset an IGSS reading.

The S, G and D are hooked up like a Gm test. The function switch is set at leakage and the type, either N or P channel, is selected. The leakage is read directly in microamps from the scale on the meter face. In most cases, any leakage at all means a bad FET.

### **No. 96: GATE LEAKAGE (IG2SS)**

If the FET is a dual-gate type, the function switch is reset to leakage IG2SS after IG1SS has been tested. Even if the number one gate has no leakage, if the second gate shows some leakage, the FET is defective. Even the slightest movement of the meter needle usually means a defective FET, just as the slightest movement of the ohmmeter needle during a capacitor test means a leaking dielectric in a capacitor.

### **No. 97: TESTING DUAL FETs**

There are many dual type FETs; that is, two separate FETs in one package. That means two source leads, two gate leads and two drain leads. The duals are tested in the same way as a single, only one at a time. If one section is defective, the entire unit should be discarded, unless you can mark, or cut off the leads of the defective unit and use the good one as a single FET.

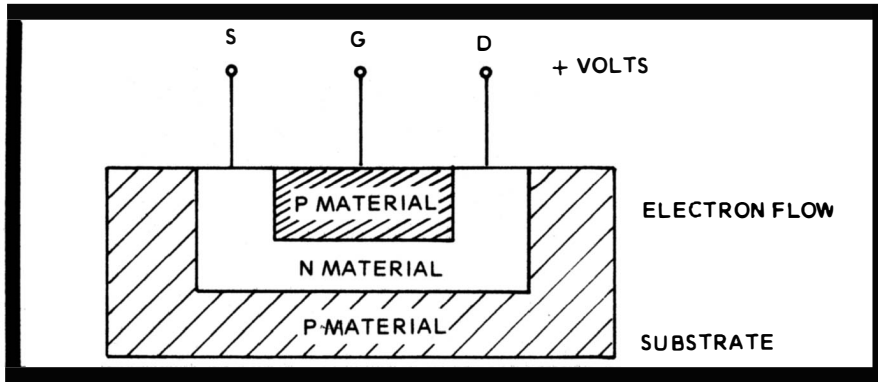

Fig. 71. The electron flow with the gate at zero bias is an important parameter,  $I_{DSS}$ .

### No. 98: MATCHING TEST FOR BIPOLARS

When matching regular or ordinary bipolar transistors to operate as a matched pair, certain parameters have to be tested. The transistors, of course, have to be the same type, NPN or PNP, and have similar or the same working voltages.

The critical parameters to check are the beta and  $I_{CBO}$  (leakage between collector and base). The closer you can get these two parameters, the better the circuit, such as a push-pull audio output stage, will be balanced and thus deliver maximum, reliable amounts of power.

### No. 99: MATCHING TEST FOR FETs

When matching FETs to operate as a pair, in addition to the devices being the same type, N-channel or P-channel and the same build, JFETs, IGFETs, etc., the important match is  $I_{DSS}$ , the "zero bias drain current." (See next few tests.) When the  $I_{DSS}$  is found nearly identical, check the  $G_m$  and be sure it is approximately close, too. The  $G_m$ , however, is not as critical as the  $I_{DSS}$ .

### No. 100: $I_{DSS}$ DEPLETION FET TEST

$I_{DSS}$ , called zero bias drain current, is the most critical FET parameter. During FET manufacture, many different  $I_{DSS}$  ratings can occur in the same batch of transistors. The finished products are tested for  $I_{DSS}$  and color coded like resistors or capacitors. When ordering replacement FETs, the color code must be specified. The color code also takes into consideration the  $G_m$ , but the  $I_{DSS}$  is more important.

The test itself is like an ordinary FET test, except when you press the IDSS button you remove the negative bias from the gate and install a zero bias (Fig. 71). That makes the source to drain current flow at maximum intensity. The channel current is not depleted at all. The actual amount of current is read directly in milliamps from the IDSS meter scale. Typical values are 5 ma, 10 ma or 15 ma.

#### **No. 101: IDSS ENHANCEMENT FET TEST**

If you try the same test with an enhancement type FET, the test is not accurate. Enhancement type FETs do not attain maximum channel current until a high forward bias is applied to the gate. A special test setup is needed to apply a forward bias. However, such a setup is not a zero bias test.

You can get some use from a zero bias test, though. Some channel current will flow at zero bias. While it is not anywhere near a maximum current flow, the amount of flow will approximate the same number of milliamps in similar FETs. You can match similar FETs on an approximate basis in this way.

#### **No. 102: FET DISSIPATION TEST**

Unfortunately, you cannot just solder an FET into a circuit as a replacement. You must calculate the amount of power dissipated across the FET, or else you can exceed the rating of the FET and blow it out in short order. The FET is rated to be able to carry a certain number of milliwatts; for instance 50, 100, or 150. You can calculate the amount of power the FET must handle in the following way:

1. Measure the IDSS in milliamps.
2. Multiply that current by the resistance of the drain load resistor. You will get the amount of voltage dropped across the load resistor.
3. Subtract the load voltage from the source voltage, which gives you the amount of voltage dropped across the FET.
4. Lastly, multiply the FET voltage drop times the IDSS. That gives you the power dissipated.

If the power dissipated is close to or more than the FET rating, better get a stronger FET, lest it break down shortly in service.

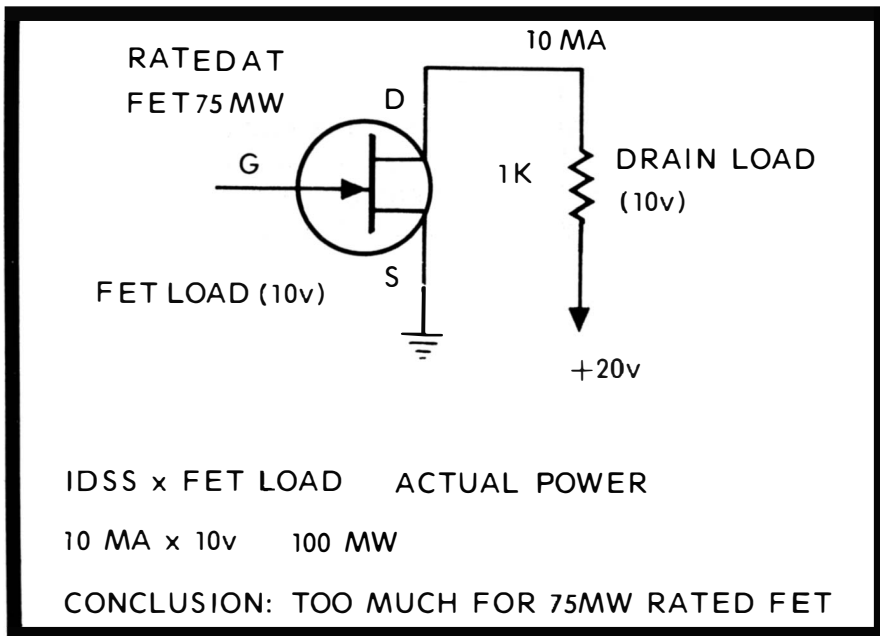

Fig. 72. FET power dissipation is obtained by multiplying IDSS times the FET load.

As an example of the above procedure, consider an FET rated at 75 milliwatts (Fig. 72). The IDSS is 10 ma. The voltage drop across the drain load resistor is 10v. The source voltage is 20v, which means the FET must drop 10v: 10v x 10 ma equals 100 milliwatts, which is too much for the 75 milliwatt rated FET. Better get a different one.

#### No. 103: HUMAN BODY GROUNDING

The IGFET and MOSFET are quite sensitive out of the circuit to such an extent that ordinary handling—even with care—can ruin the device. You must observe care when removing them from packages and attaching test leads. Once the test loads are attached, the sensitivity is decreased drastically. The big danger is from static charges, even tiny hard-to-measure amounts of static voltage. You must ground the static charge in your body before touching them. Attach a clip lead from a ring or metal watch band to a chassis ground point on the test equipment that will be used. Then you can remove the device from the package.

#### No. 104: MAINTAINING SHORTED LEADS

The IGFET and MOSFET are packaged and shipped with the leads purposely shorted together. This reduces static charge

danger. When attaching these devices to the source, drain and gate connections, keep the shorted leads in contact, until you make all the connections. Failure to do this could introduce a static charge and ruin the device.

#### **No. 105: SOLDERING PRECAUTIONS**

Do not use a solder gun. Use as low a wattage iron as possible, just enough heat to melt the solder. Heat sink protection for the body of the device is a must. Attach a ground lead from the barrel of your soldering iron to the piece of test equipment that is being used. Be sure the test equipment has a 3-prong plug and is plugged into a correct wall plug that provides a good ground. Never solder an FET while the circuit has any power supplied at all. On occasion, a battery-operated circuit might be accidentally in an on position. If it's at all possible, remove the battery during the soldering operation.

#### **No. 106: FET OSCILLATION TEST**

Most transistor testers do not usually provide a means of checking an FET's ability to oscillate. Test manufacturers will argue that if an FET shows good  $G_m$  and leakage tests, it will oscillate according to its design capabilities. However, this is not good enough when you are building an oscillator and want to be sure.

If you build a little grounded gate Colpitts oscillator, you can check the oscillation by installing a diode and microammeter in the source leg. The oscillator could be designed to run at around 100 MHz, assuming that if it does run at that frequency, it will run at lower frequencies. With the circuit shown in Fig. 73, if the FET starts oscillating, the source current will be rectified and move the ammeter needle. Different frequencies can be tested with different size drain feedback coils. An ammeter reading means the oscillator is running. No reading means it's not.

#### **No. 107: FET OSCILLATION LIMIT TEST**

You can find out just how high a frequency and FET will oscillate by changing the drain feedback coils for others with fewer and smaller and smaller fewer turns. According to the rating of the coil, the oscillator will tend to run higher and higher in frequency. When you attach a coil and the oscillator will not turn on, the limit of oscillation of that FET has just been reached. The limit is between the last coil that did work and the one that won't work.

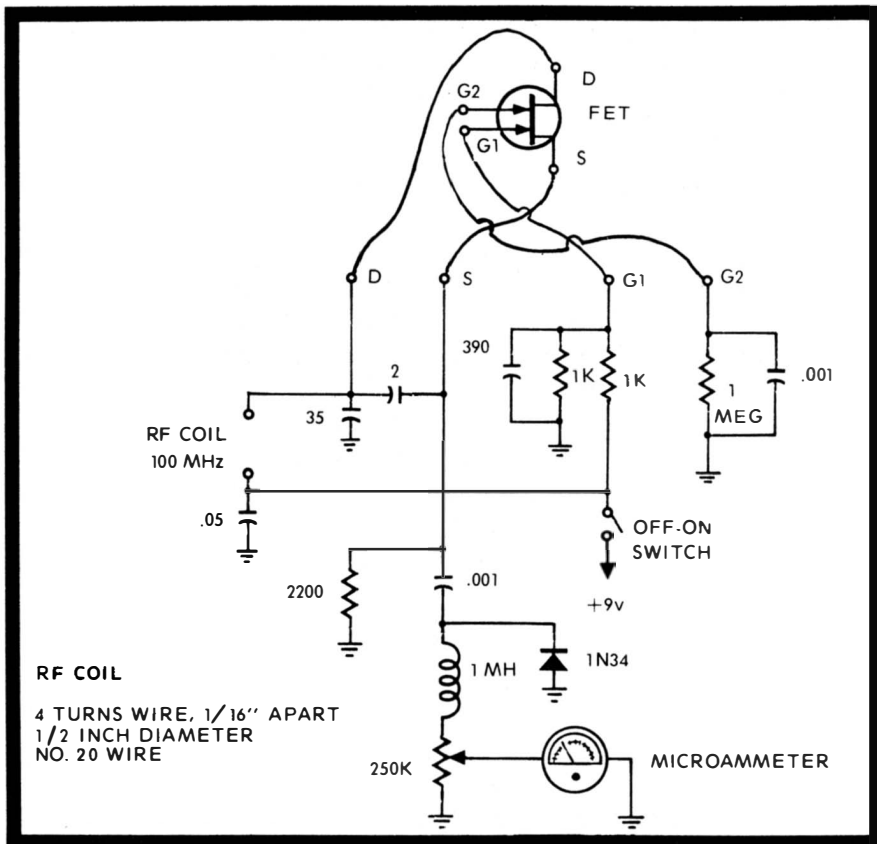

Fig. 73. You can tell whether or not an FET will oscillate by connecting it to this circuit.

#### No. 108: TRANSISTOR-FET FREEZE TEST

When a transistor or FET is suspected of intermittent operation, the freeze test frequently will make the defect appear. Attach the transistor tester to the suspect while in the circuit. Keep the equipment turned off. Take a beta or  $G_m$  reading at this static condition. Note the reading.

Then spray freeze the transistor. Wait until the frost appears on it and press the gain button again. If the beta or  $G_m$  is just about the same, the transistor is testing OK. However, if the gain changes drastically or no reading at all is obtained under the freeze condition, the transistor is defective.

#### No. 109: TRANSISTOR POTENTIOMETER TEST

When testing a transistor in a circuit, if there is a potentiometer in the base circuit, such as a volume control, you can use it to verify a test.

When the pot is across the base without a blocking capacitor, it is a variable shunt resistor (Fig. 74). With the transistor tester attached in the circuit (with the equipment turned off), take beta readings at different pot positions. At minimum, when the pot is shorting out the base, the transistor will act as if it is shorted. As you then vary the pot, different readings will show up on the meter. This is normal.

If the same readings keep showing, the transistor is defective. Also make sure that you do not inadvertently take what you consider is a valid reading while the pot is shorting out the base at its minimum setting.

### No. 110: LO-POWER OHMS FUNCTION TEST

Every technician has had to go through the trouble of disconnecting components in a circuit in order to make a resistance test. Of course, it is much easier to make in-circuit tests. In tube-type circuits it's easy to make in-circuit tests by figuring what resistance is in a circuit that is being measured.

In transistor circuits this ability runs into a complication. The normal 1.5-volt battery causes enough current to flow in the circuit to turn on the transistor (Fig. 75). As the transistor

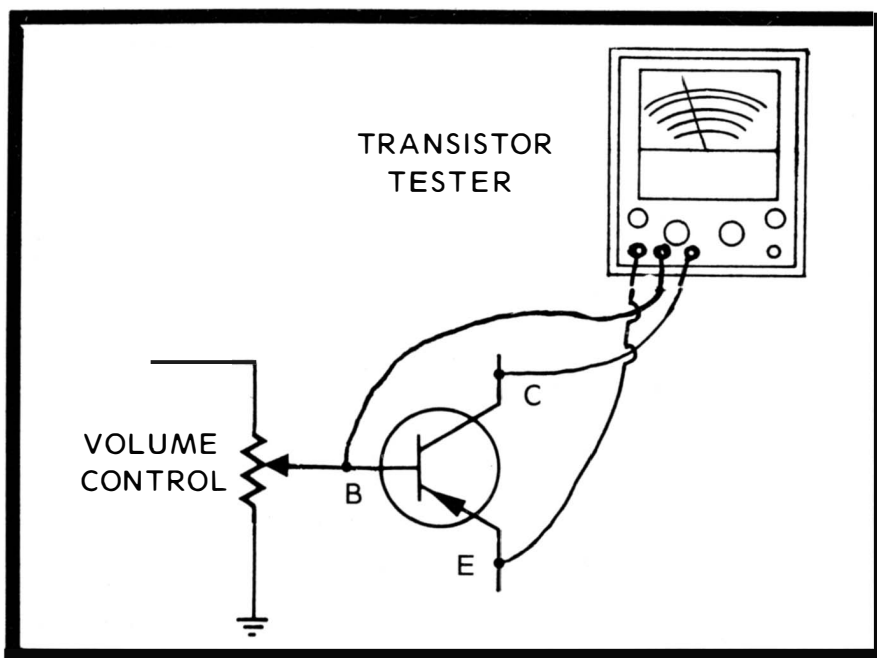

Fig. 74. Be careful when making a transistor test in-circuit. Look out for any low resistance or pots in the base.

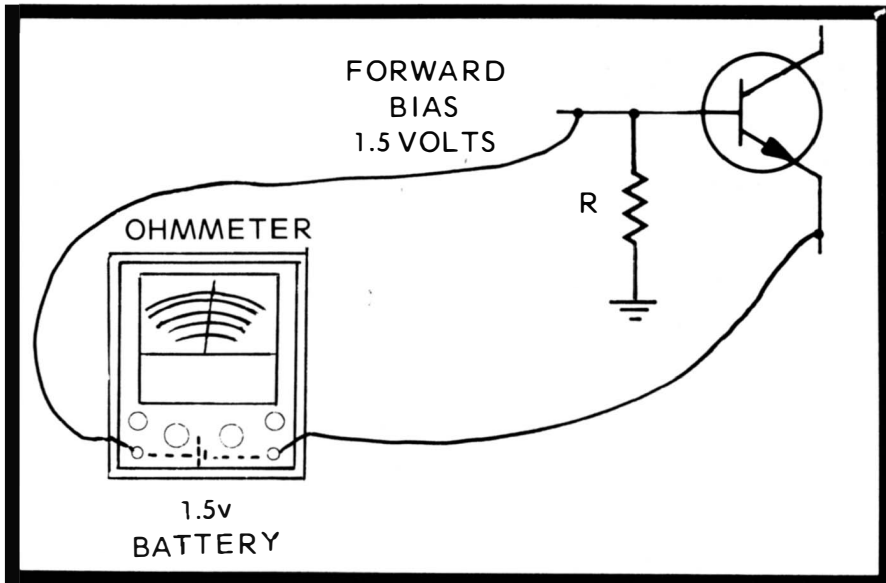

Fig. 75. Conventional ohmmeters with 1.5v batteries turn on a transistor during a routine ohmmeter test and makes the test worthless.

conducts, the ohmmeter needle arrives at incorrect positions. A 100K resistance can read anywhere from a few K to 100K, according to the point where the meter is connected. There is a way to avoid the problem and still be able to test in-circuit.

Germanium transistors turn on when a forward bias is applied with a voltage of about 0.2. Silicon transistors turn on with 0.6 volt. In order to be sure, the 1.5-volt battery output must be reduced to under 0.1 volt. Lo-power ohmmeters are appearing on the market (the Sencore FE160). They provide an ohmmeter voltage at the test probes of no more than 0.08 volts. This is low enough not to turn on any transistors. In-circuit tests can be made without getting false readings.

The 1.5-volt output has to be available, too, since many of schematics show resistance and back-to-back measurements dependent on the 1.5-volt output. The Lo-power function though, can be used in many, if not most, applications.

### No. 111: AN EVEN LOWER POWER OHMS TEST

Even though the general rule is that germanium transistors need 0.2 and silicon needs 0.6 volts of forward bias to conduct (Fig. 76), large, heavy current transistors made of germanium will turn on at the Lo-power 0.08 volts. There are



always exceptions. How can these transistor circuits be tested?

You can lower the battery output even more with a high-value resistor. It has been computed that if you put a 100K resistor in series with the line, the voltage is reduced to 0.008 volts. An isolation probe such as this is usually available with a Lo-power ohmmeter.

### No. 112: SMALL THERMISTOR TEST

Small thermistors, which are being used more and more in solid-state circuits, are difficult to test with a conventional ohmmeter. Thermistors are usually rated at their higher "cold" resistance. As they heat in use, thermistors drop in resistance. If you measure them hot the resistance reading will not be correct.

If you use a Lo-power ohmmeter, the low voltage output of 0.08 volts does not provide enough current to pass through the thermistor to heat it up and thus lower the resistance. It turns out the only way you can test the thermistor is by using the Lo-power ohmmeter.

### No. 113: FIGURING DIODE POLARITY

During servicing, diodes have to be replaced and it is rare that the available replacement is identical to the original. They come in all types, sizes and shapes. It is important that you replace a diode with the same polarity as the original. If you don't, the diode might not work and could even cause an electrical dead short.

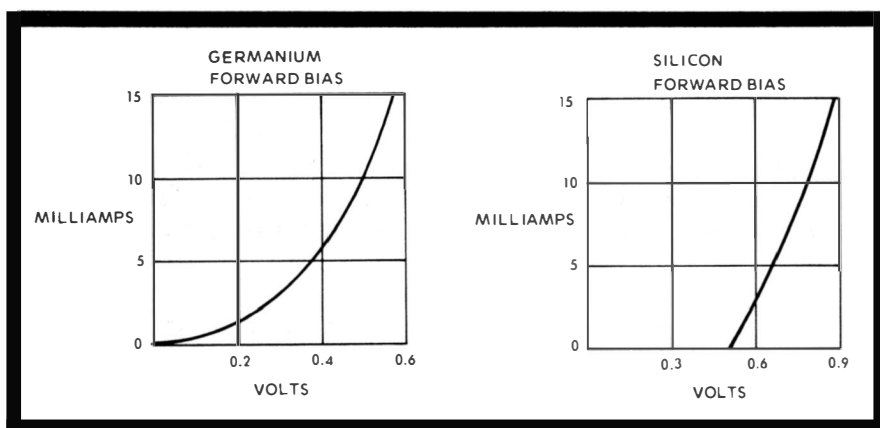

Fig. 76. Germanium transistors turn on as the forward bias approaches 0.2 volts. Silicon needs about 0.6 volts.

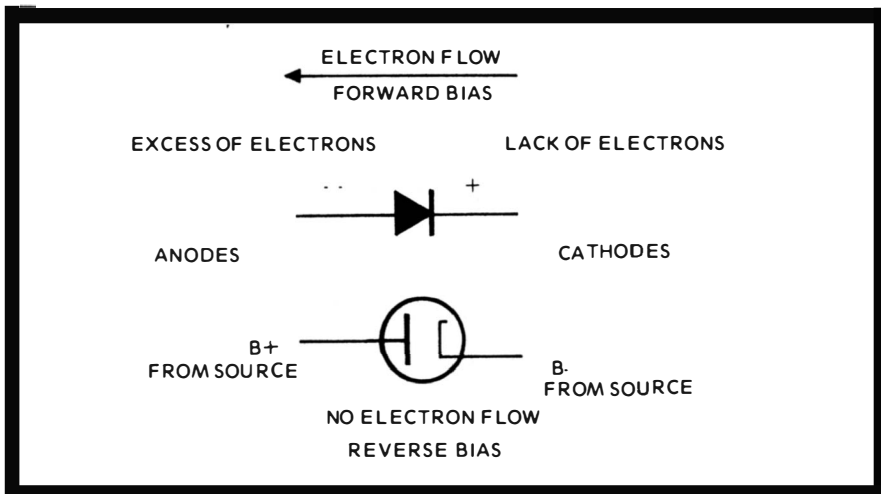

Fig. 77. Diode polarities can be confusing since they are marked positive on the cathode and negative on the anode.

Some confusion exists in the replacement situation. Diodes are marked plus and minus. The plus is on the cathode and the minus is on the anode. This is opposite to the forward bias power supply voltage that is usually provided. The power supply provides a plus voltage for the anode of a tube or solid-state diode and a relative minus voltage to the cathode for forward biasing.

The plus on the diode cathode means there will be a lack of electrons there and an excess of electrons on the anode (Fig. 77). The electron flow will be from the area of insufficient electrons on the plus cathode to the area of excess electrons on the minus anode. That is forward bias.

When you see a diode symbol, it looks like an arrowhead against a bar. Forget the arrowhead idea. Think of the object as a triangle. The bar is the cathode and the triangle is the anode. Forward bias on the diode is shown on the ohmmeter as a low resistance. Reverse bias on the diode is indicated a high resistance. Forward bias causes electron flow from plus to minus in the diode. Reverse bias prevents electron flow from minus to plus in the diode.

#### No. 114: TESTING DIODE IN-CIRCUIT

Most transistor testers check diodes and power rectifiers right in a circuit, which is handy since it avoids some soldering. With the equipment off, the emitter lead is attached to the cathode of the diode. The collector lead is attached to the

anode (Fig. 78). The type switch is set on NPN. Some current will flow through the semiconductor material.

Turn the calibration knob fully clockwise. If the meter will go upscale, the diode is working and is capable of diode action. If it won't move, it is either shorted or open. Then you can remove it from the circuit.

### No. 115: TESTING DIODE OUT OF CIRCUIT

Once you get an indication that a diode is bad, or you want to test a new one before installing it, an out-of-circuit test will verify its quality in a definite manner.

The leakage test position of the transistor tester provides the accurate test. Attach the base and collector leads to the cathode and anode of the diode. Then switch the type selector from NPN to PNP and back (Fig. 79). A good diode will read on opposite ends of the scale for each setting of the type switch. It's an excellent go-no go test of forward and reverse current.

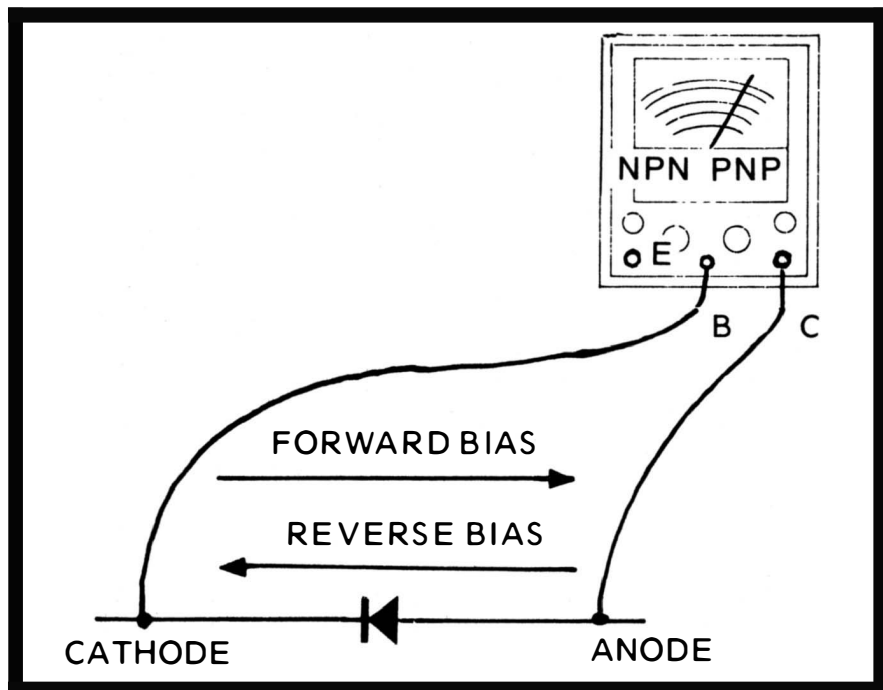

Fig. 78. Diode polarity can be determined with the B and C transistor tester leads. Forward bias will deflect the needle.

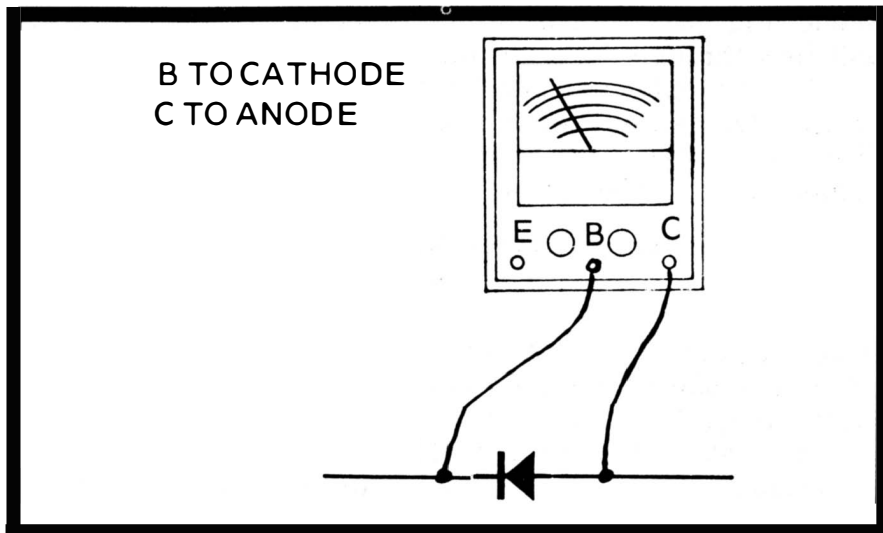

Fig. 79. Diodes can be tested out of circuit by attaching to B and C tester leads.

#### No. 116: GRADING THE DIODE

A good diode used in audio or a video detection type should have a forward-to-reverse microamp current ratio of at least ten to one. The preceding test, if read carefully, will tell you if the diode is satisfactory or not. A good germanium diode should not read any more than 40 or 50 microamp reverse current. The meter reads it directly. Forward current should be at least 500 microamps or better.

The heavier duty silicon rectifier should have an even higher ratio. A good one will show 4 or 5 thousand microamps in the forward position and absolutely no leakage on the ordinary transistor tester (it's too small to measure with that instrument) on the reverse bias setting.

#### No. 117: VARICAP DIODE TEST

One of the most important tests of a varicap diode is its reverse current leakage. This is easily accomplished on the transistor tester. Too much reverse leakage ruins the variable capacitance effect of the special diode. It's not enough to know that the diode is working; it's how well it is working. It is used in frequency-sensitive locations and can kill sensitivity, output or correct frequencies. A varicap is like a silicon diode and

should read practically none, or actually no reverse leakage on the ordinary transistor tester. Attach the diode to the base and collector leads (Fig. 80). Try both NPN and PNP positions. One will read forward and the other reverse leakage. A good one will read no reverse leakage. Even a little reading indicates the diode could be in poor condition for its job.

### No. 118: ZENER DIODE KNEE VOLTAGE

During construction of electronic gear, or servicing, you might get a zener diode without markings. While it might be the unit you need, it's risky to install it in a critical circuit unless you know that it is operating properly.

Zener diodes are made of silicon with a very special characteristic. In fact, the applications for zener diodes do not resemble ordinary diode applications at all. The ordinary diode has the job of changing AC to pulsating DC, or rectification as it's called. The zener diode is a voltage regulator. It keeps a voltage at a specified reference level, no matter what amounts of current are passed, within the operating limits of itself.

Usual silicon zeners can control voltages from one on up to hundreds of volts. The power ratings can be as low as a fraction of a volt on up to a hundred or two volts. Zener diodes

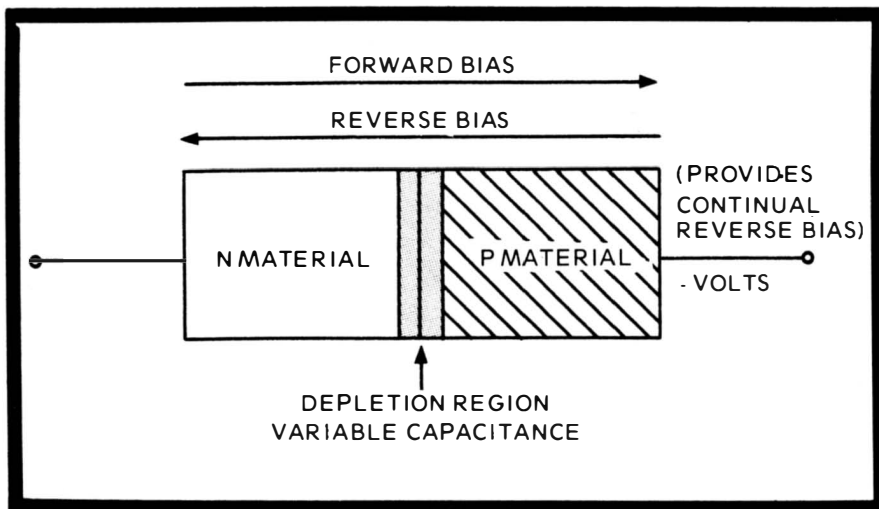

Fig. 80. A varicap diode is operated only with reverse bias. During forward bias there is no variable capacitance.

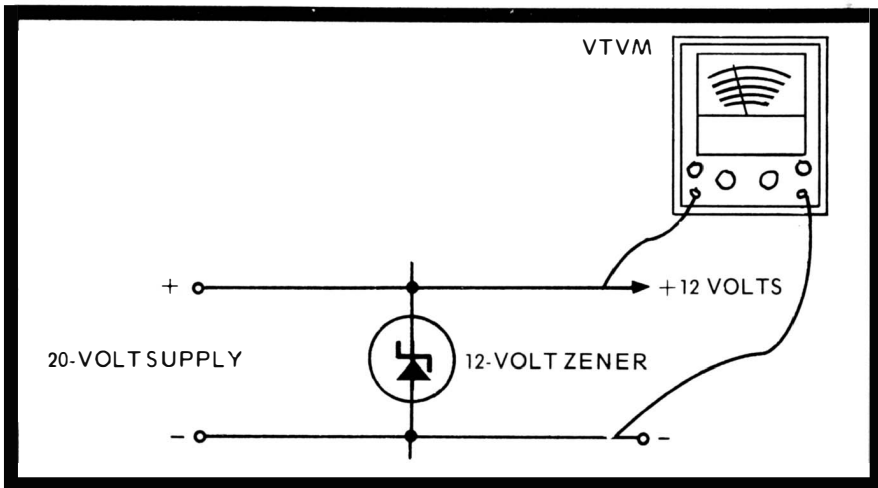

Fig. 81. A zener diode can be tested by installing it in a test circuit, with cathode toward the positive voltage.

are like other silicon diodes except for one characteristic. At a particular voltage in the reverse bias condition, the zener suddenly stops being a high resistance to electron flow and becomes a tiny resistance. This causes a heavy current flow at this voltage and no matter how much more voltage is sent in, the heavy current flow continues and holds the voltage at that particular point.

The voltage where the zener turns from a high resistance to a small resistance, where the sharp break causes the sudden heavy conductance, is called the zener "knee." The word is taken from the appearance of the graph curve of the characteristic. That knee voltage also designates the name of the zener. For instance, it could be called a 12-volt zener, or a 190-volt zener.

To test a zener, get a power supply, a radio, TV, or any kind of electric unit that provides a voltage that is somewhat higher than the voltage the zener rating (Fig. 81). Turn on the supply and take a voltage reading of the DC output across the load. For instance, suppose it's a 20-volt supply and you are going to test a 12-volt zener. You'll test first and make sure there is the correct 20 volts across the load.

Next, attach the zener cathode, which might be marked plus, to the 20-volt end of the power supply. Attach the zener anode, which might be marked, negative, to the ground or the supply chassis, whichever is B minus.

Then turn on the supply and take another voltage reading. This time the power supply will come on, but measure only 12

volts. The voltage, since it exceeded the knee of the zener, simply pumps current through the zener as current was pumped the voltage dropped. At the 12-volt setting, the amount of current is stabilized. Only a certain amount of current flows because as the voltage goes below 12 volts, the zener shuts off conduction. As the current tends to stop, the voltage stops dropping. The zener has many uses and is becoming a common component.

### No. 119: COMPONENT SUBSTITUTION TESTS

One of the surest ways to test a suspected component is to clip a known good component of similar value into its place. The various so called "decade boxes" are devices that offer many component values through clip leads. There are substitute resistors, capacitors, rectifiers and filters all built into a handy unit. When you suspect a component, all you do is disconnect one end of it and attach the clip leads in its place. If the electronic unit returns to normal operation, the test has proved the suspected disconnected component was defective.

This test is so effective that many electronic units are repaired every day without use of any other test equipment or

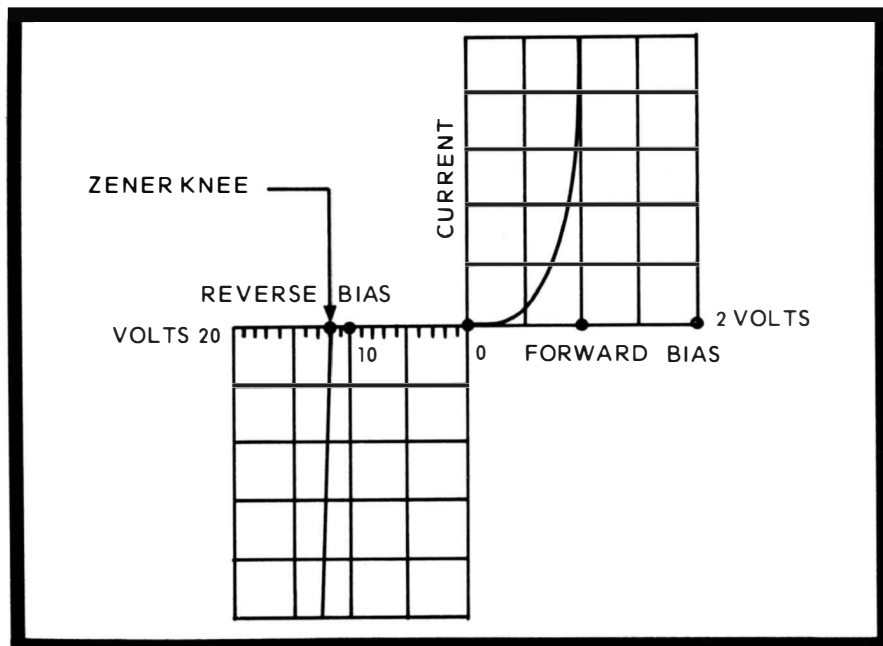

Fig. 81A. The zener knee represents the main characteristic of a zener diode. Conventional diode activity is not used.

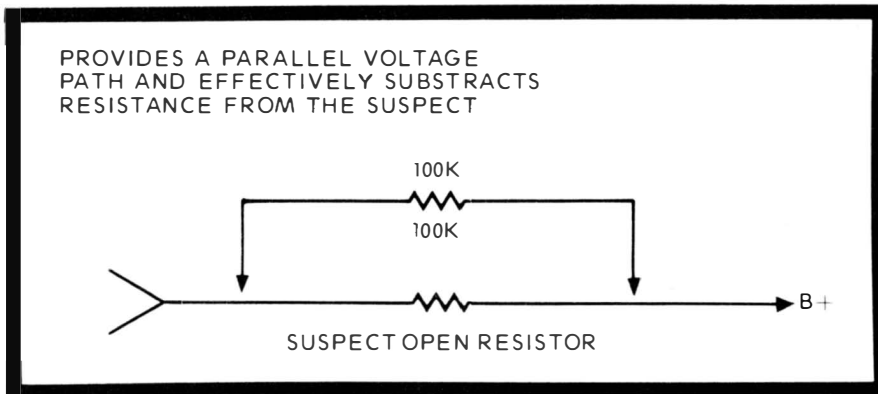

Fig. 82. By installing a known good resistor across another resistor, they form a parallel circuit and subtract if the original resistor is OK.

even knowledge of theory on the servicer's part. This "snip and clip" test also can be used with actual components, but a decade box is much handier and reliable.

### Component In-Circuit Bridge Tests

There are many in-circuit tests that can be made using a component, either singly or from a decade box. These are bridge tests and no disconnection of parts is needed. These tests are limited in scope, due to the fact that the circuit is not opened. Fortunately, though, the tests are valuable since they find a large percentage of bad components.

#### No. 120: SUBTRACTING RESISTANCE TEST

One of the major resistor failures is an increase in value or an open which makes the resistance infinite. The resistor becomes suspect when a wrong voltage appears on a cathode, collector, etc. The voltage can be high or low, depending on the position of the resistance in the circuit.

If there is nothing in shunt with the resistance, it can be measured directly with the ohmmeter. However, more likely than not, there is usually something in shunt. A good test is to bridge the resistor with another of the same value (Fig. 82). According to basic mathematics, if the resistor is good, you'll be providing an additional path of the same value for the current and, therefore, cutting the resistance in half.

If the resistor has increased considerably in value, the substitute resistor will carry most of the current flow. In effect, you have subtracted resistance from the suspect. A



recheck of the voltage on the test point is appropriate. If the voltage has become normal, the suspected resistor has definitely increased in value and is defective.

#### No. 121: ADDING CAPACITANCE TEST

A capacitor can fail in one of four ways. It can short completely, develop a high-resistance short, open, or change in capacitance value. The addition of capacitance as a test indicates three out of the four types of failures, but it can't help a dead short.

You can add capacitance directly to an in-circuit capacitor by simply bridging another similar unit across it (Fig. 83). For instance, if you bridge a .05-mfd capacitor across a suspect, you add .05 to it. If the capacitor has a high-resistance short, it is no longer a capacitor but a resistor of that value. If the capacitor has opened, it's just an open connection. Should the capacitor have changed value, it always changes to a much lower value. Adding capacitance in any of these cases provides a positive indication of a defective capacitor.

#### No. 122: ADDING RESISTANCE TEST

While resistance can be subtracted without unsoldering, adding resistance usually entails the use of a soldering iron, unless the test spot is some form of plug-in. It is necessary to add resistance to the circuit if a suspect resistor has decreased in value, or if you are building a kit and feel you need more resistance at a particular spot. Then you must unsolder one end of the existing resistor. If one end is on the chassis, that's

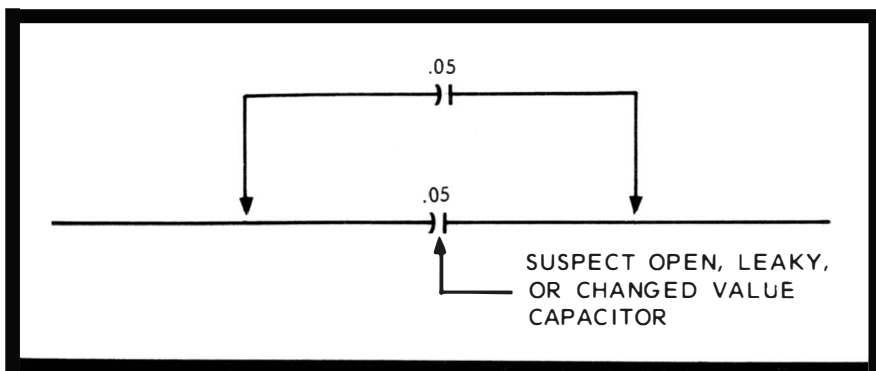

Fig. 83. By installing a known good capacitor across another capacitor values add.

the end to unsolder. Try not to unsolder any connections directly to a heat-sensitive device like a transistor. In tiny circuits, be sure to heat sink as you unsolder. Once an end is disconnected, you can add resistance by attaching the substitute between the loose end and the point where it was connected, or substitute another resistor or the entire disconnected resistor.

#### **No. 123: SUBTRACTING CAPACITANCE TEST**

An existing capacitor can be lowered in value by putting another capacitor in series with it. If they are both the same value, the capacitance will be halved. Once a capacitor end is disconnected, you can add another capacitor to it, and a certain amount of capacitance will be subtracted, depending on the value of the added capacitor.

#### **No. 124: IN-CIRCUIT TRANSISTOR AUDIO WAVEFORM TEST**

Any transistor that has to pass an audio frequency can be tested in the circuit under dynamic conditions with a signal generator and an ordinary scope equipped with a high-impedance probe. By putting a sine wave in and viewing what the sine wave looks like when it comes out of the transistor, you'll get an idea of the transistor's quality.

Attach the generator output, through a capacitor larger than the base input capacitor in the circuit, into the base of the transistor. Set the generator for an audio output around 1 kHz, turn on the generator and the amplifier. Attach the scope probe to the amplifier output and set the scope to display the 1 kHz generator signal. Observe the scope display. One of four things will happen. One, the sine wave will be excellent. Two, the positive peaks will be clipped. Three, the sine-wave negative peaks will be clipped. Four, both peaks will be clipped (Fig. 84). If it's one of the last three, the transistor is not working properly. Try a few different ones until you get a perfect sine-wave display on the scope.

#### **No. 125: IN-CIRCUIT TRANSISTOR AUDIO FREQUENCY RESPONSE TEST**

Using the same test setup mentioned in the previous test, once you have a good transistor passing a 1-kHz sine wave, set the signal level at a normal listening level. Then start raising the

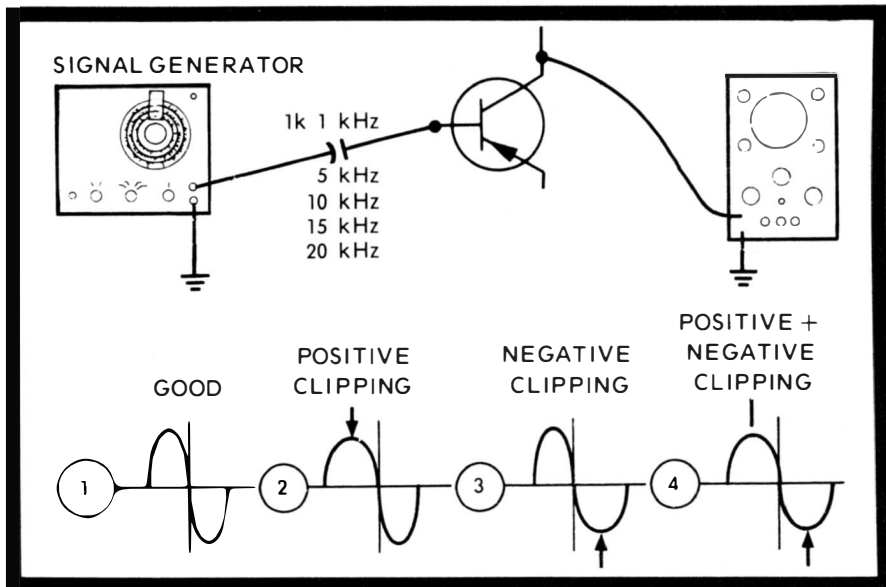

Fig. 84. The amplification and frequency response of an audio amplifier can be checked with a signal generator and a scope.

frequency in steps up to the rated frequency response of the amplifier. For instance, if it's an FM receiver producing audio up to 20 kHz, raise the frequency in steps, like 5 kHz, 10 kHz, 15 kHz and then 20 kHz.

Observe the sine wave. Some clipping will occur, but if the sine wave remains basically the same, all the way up the scale, the transistor is good. Should the sine wave start clipping at a lower frequency, it's not responding properly.

### No. 126: POWER TRANSFORMER OUTPUTS

Power transformers are found in a variety of electronic gear and serve many complex applications. Usually, it has a single primary and a step-up secondary for B+, step-down secondaries for various heater requirements and a center-tapped secondary for full-wave rectification. These voltages have to be tested.

The voltmeter is set for AC and the probes are attached to the various test points in the transformer. If the 117v AC is correct going in, then the secondaries should have appropriate voltages; for instance, 250v AC across a step-up secondary and 6.3 volts or 5 volts across a step-down secondary.

## Chapter 9

# Power Supplies

### No. 127: CHECKING RIPPLE IN POWER SUPPLY

A power supply that changes AC to DC is changing a sine-wave input to a DC voltage. Most ordinary power supplies do a satisfactory job, but cannot get all of the AC out of the DC. The remaining AC is called "ripple" (Fig. 85). It is useful to check ripple voltage. Hum in radios or weaving in TV pictures can be caused by excessive ripple. Too much ripple indicates defective filter capacitors.

Ripple can be checked with a scope or the p-p scale of a multimeter if it is sensitive enough. When the scope is used and the peak-to-peak ripple is compared to the 117-volt amplitude, it's a rough check, unless you actually measure the ripple with a ruler. Of course, the scope can be calibrator for p-p readings. The multitester indicates the ripple voltage directly on the meter scale.

### No. 128: ACCURATE VOLTAGE TESTS

During troubleshooting it is necessary to take voltage readings. For practical purposes it is not mandatory that readings be right on the nose. In most cases, an accuracy between 10 and 20 percent is permissible. Any more than 20 percent can throw the servicer off his path. As a result, the choice of a voltmeter is important.

VOMs are the handiest since they are portable and can be used anywhere without the need for 117-volt electric power. VOMs, though, should be used judiciously, since they load down a circuit and introduce large errors.

Suppose you are going to test a transistor amplifier. The first place a test can be made is at the base to see if the transistor is correctly biased. If a conventional 20,000 ohms per volt meter is used, the bias would be more than 20 percent off and provide a false trouble clue. The VOM loads the circuit, and, when it is attached, acts just as if you connected a 50,000-ohm resistor across the 33,000-ohm base-to-ground resistor (Fig. 86).

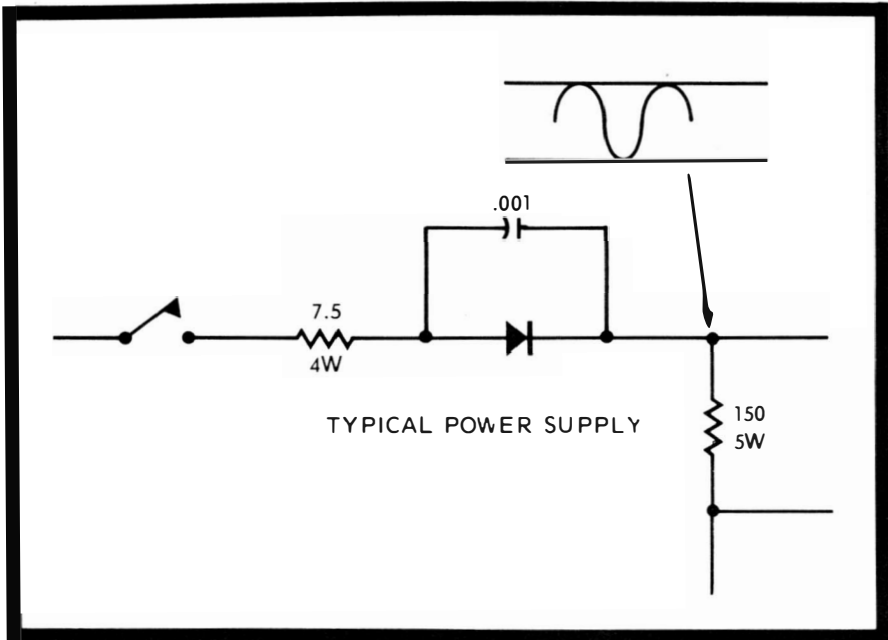

Fig. 85. Ripple voltage is usually too low to cause trouble, but it's useful to have the capability to test it.

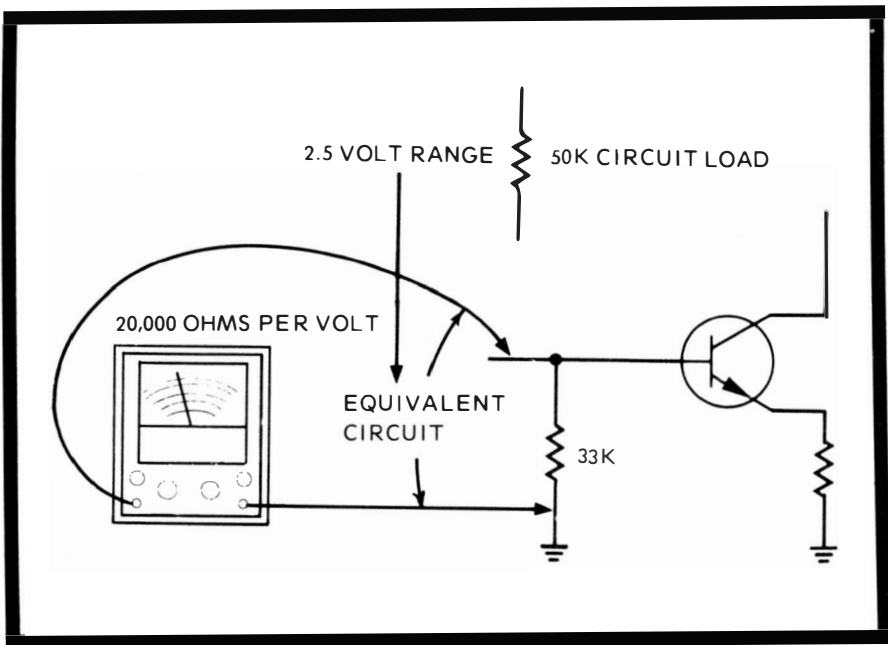

Fig. 86. Using a 20,000 ohms-per-volt VOM in the 2.5-volt range is like putting 50K across the circuit.

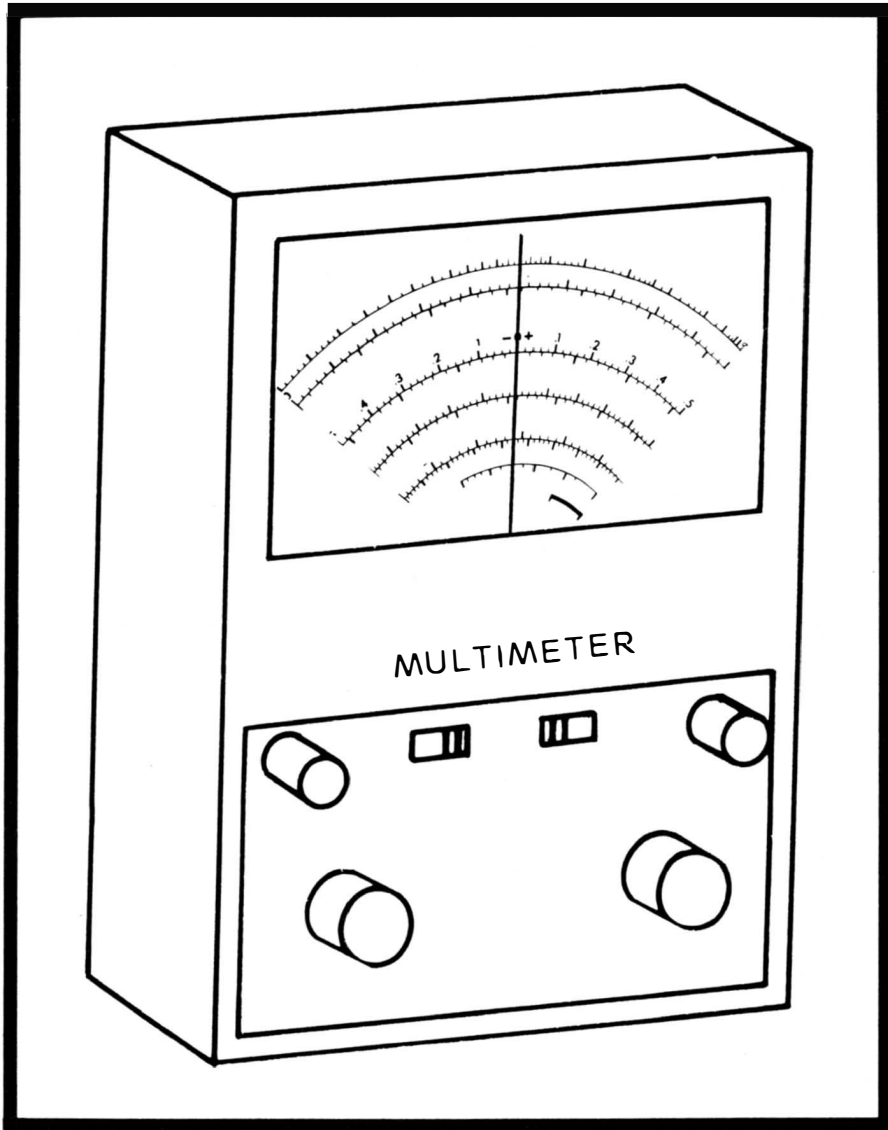

Fig. 87. Most multimeters have a zero-center scale. In some cases, it's very useful.

Figuring it roughly, the 50K across the 33K changes the effective base resistor to 20K. The bias voltage drops, the transistor loses its forward bias and cuts off. All the voltages in the circuit are then incorrect. To make accurate voltage readings a voltmeter with a high impedance—in the megohms—has to be used. Then the 33K stays near its 33K effective value.

## No. 129: ZERO CENTER RANGE TEST

There are many different tests where the zero center range of voltmeter is mandatory and there are others where it is faster to use a zero center than conventional polarity switching. Discriminators, ratio detectors in FM and TV sets, automatic fine tuning—in fact, any dual-diode phase detector calls for a zero center scale. In solid-state circuits the voltages are relatively small and range both ways from center. The zero center is faster than switching the emitter polarity from plus to minus.

Manufacturers specify in TV and FM alignment notes that certain adjustments must be made with zero center. Whatever the test, the zero center is set up like this: The appropriate plus DC scale is selected, the zero adjust knob is turned until the meter needle arrives at the correct setting. There is usually a zero setting at midscale (Fig. 87).

Then the circuit is explored. A reading to the right of zero is a positive reading. A reading to the left is negative. For instance, suppose you have a color TV with a color sync phase detector that is supposed to have minus 35 volts on the top diode and plus 35 volts on the bottom diode. You touch the meter probe to the top diode and the needle goes to minus 35 volts downscale. Then you touch the bottom diode and the needle goes to plus 35 volts upscale. That is correct, too. That's a lot easier than switching the scale polarity from plus to minus.

# Chapter 10

## Remote Control Systems

### No. 130: TRANSMITTER OR RECEIVER, RF TYPE

Without exception, all remote control systems consist of two main parts—the transmitter and the receiver. In an RF-type remote system, such as is used in controlling aircraft flight, robot controls that are some distance from a transmitter, dynamite blasts and the like, trouble develops in the transmitter or receiver, but not ordinarily in both.

It is necessary to localize the problem to one or the other of the units (Fig. 89). A field strength meter that can tune to the transmitter frequency will isolate the problem to one unit or the other. Simply turn on the transmitter and take a reading on the FS meter. If a normal microvolt level is being received, the transmitter is fine and the receiver, by elimination, has a problem. Conversely, if the field strength meter does not record a normal output from the transmitter, then the transmitter is at fault and the receiver is probably good.

### No. 131: TRANSMITTER OR RECEIVER-AUDIO TYPE

While the RF transmitter type of remote control is quite well known, there are just as many audio type remote transmitters around, such as found in remote controlled TV (Fig. 89).

An audio transmitter is quite similar to the RF type, except for the operating frequency and its actual output. While the RF type transmits radio waves of various high frequencies, such as 465 MHz and 27 MHz, the audio transmitter sends out sound waves, such as those between 35 and 45 kHz. Such frequencies are above the human hearing ability, which reaches only 20 kHz as the upper limit, generally, but are still sound waves. In an audio-type transmitter, instead of an antenna that radiates RF, a transducer changes the electronic 40-kHz signal to a mechanical 40-kHz sound wave which travels toward the receiver.



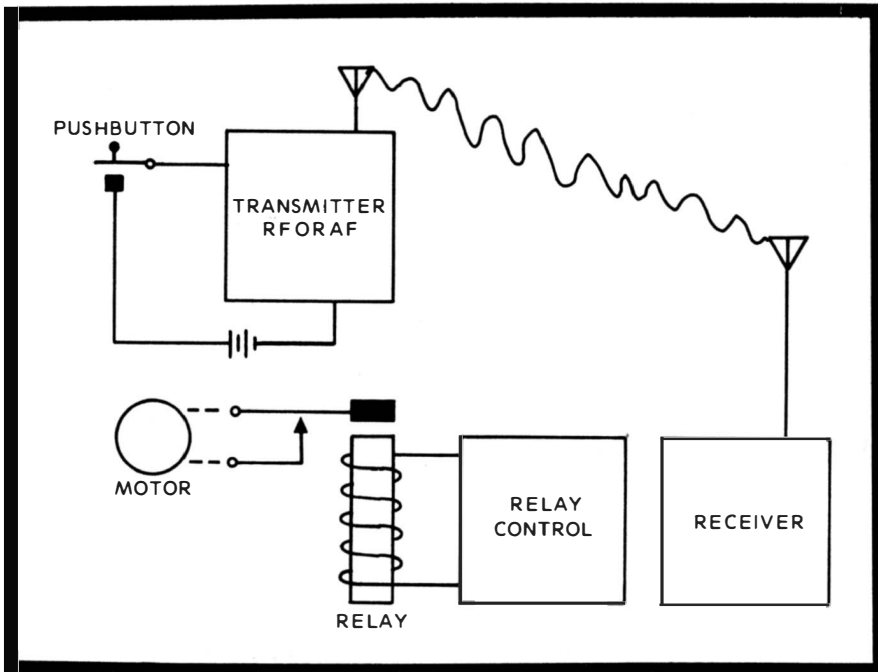

Fig. 88. The typical remote control transmits a signal and closes a relay to start a motor.

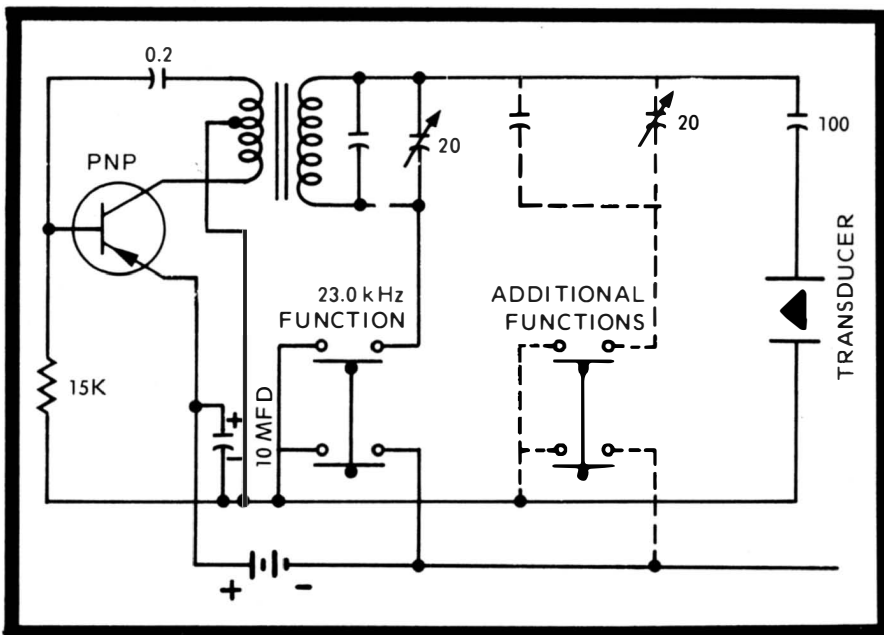

Fig. 89. The transmitted wave can be in the audio range. It is produced by a transducer which creates sound waves in the air.

The transducer is basically a capacitor-type microphone with metalized mylar plates. The signal causes the plates to vibrate at 40 kHz, which creates the sound wave. In the receiver, an identical transducer “hears” the 40-kHz waves and its plates respond sympathetically. As the plates are moved by the audio waves, the capacity is physically changed in direct proportion and the DC potential in the circuit is modulated. The 40-kHz signal is then processed in the receiver.

When problems arise and it's necessary to determine if the problem is in the transmitter or receiver, an audio generator that can be tuned near the output frequency is needed; typically, a variable zero to 50-kHz type. The generator is substituted for the transmitter and turned on. If the receiver responds normally, the transmitter is isolated as the trouble maker. Should the receiver still not perform, the transmitter is probably good and the receiver contains the trouble.

Remote control systems can be as simple as one circuit in the transmitter and one circuit in the receiver. On the other hand, a remote control system can be complex almost beyond belief, such as is found in the remote control systems used in drone aircraft, bombs, and space probes.

No matter how simple or complex, they all perform a similar function. An operator presses a button, rotates a potentiometer, a variable capacitor, flicks a switch or some similar motion and somewhere else a form of motor turns on and moves an aileron, fires a rocket, explodes a bomb, turns on a TV camera and so forth. It's all basically a switch that turns on a remote type of motor.

The transmitter and receiver can be in the same room, so you may change TV channels without arising from the chair, or the transmitter and receiver can be 50 million miles away as a space probe lands on Mars. Usually, the audio type remote is in the same room and the RF type is separated by such a distance that an audio system is not strong enough.

A fairly complex remote control system that the electronic hobbyist will possibly encounter is found on color TVs. Remote TV controls perform all kinds of functions can do ten jobs or more. Also, the same principles exist in other remote control units. If you can test and understand this type of remote, the others you will possibly come into contact with are simpler and this experience will almost assure you an understanding of them. The typical color TV remote system usually has a transducer output, although some do transmit in RF signal out of a tiny antenna system.

## Remote Control Transmitter

A typical TV remote control transmitter is hand held and is no larger than a pack of cigarettes. It can produce eight functions. Each function occurs because the transmitter is sending out eight different audio frequencies.

The transmitter oscillator transistor collector is connected to the power supply through the primary of a step-up transformer. The negative side of the battery is attached to the collector circuit. This means electrons flow from the battery to the collector and then to the base and emitter. The 0.2-mfd capacitor couples some feedback from the collector circuit to the base in order to sustain oscillation. In the secondary of the transformer, there are a number of tank circuits tuned to the desired frequencies. A transducer turns the frequencies produced into audio air waves.

When any of the function buttons are pressed, the negative end of the battery is connected into the circuit. Collector current flows from the battery into the transistor. The rising current induces a stepped up voltage in the secondary of the transformer which is tuned in accordance to the choice of tank circuits as chosen by the button pressed.

A negative-going feedback pulse is simultaneously coupled from the collector circuit to the base. The base draws electrons from the collector and charges the capacitor. As the transformer voltage arrives at its correct level, the feedback pulse ceases. The charge on the capacitor turns off the transistor as it reverse biases the base-to-emitter junction.

The tank circuit rings and sends another negative-going pulse, through the transformer, through the capacitor, to the base and turns on the transistor again. The cycle keeps repeating itself at the proper frequency as long as the button is being pressed.

The secondary of the transformer is tuned to 23 kHz, the highest desired frequency that the oscillator is called on to produce. Actually, 46 kHz is transmitted when the oscillator is running at 23 kHz. That's because this transducer, by its very nature, doubles any frequency it has to radiate.

With a voltage difference applied between them, a transducer's plates are pulled toward each other. Therefore, on the positive half cycle, the plates are pulled towards each other. Then, when the frequency passes through zero, the plates return to their at-rest position. When the negative half cycle occurs, they are attracted towards each other again. At zero they go back to their rest position. There are two transducer beats during each full cycle or Hertz. Twenty three kHz

in the oscillator produces 46 kHz transducer output. The same thing is true for all the other oscillator frequency outputs.

On an 8-function transmitter such as this one, there are, of course, eight buttons or switches. Each button connects a different tank circuit in parallel with the tuned secondary of the transformer. As each button in turn is pressed, more capacity is added to the tuned circuit. The additional capacity lowers the resonant frequency; therefore, each button lowers the transmitted audio frequency. For instance, the third button might cause 21 kHz to ring in the oscillator. The transducer doubles it and radiates an audio tone of 21 times 2, or 42 kHz.

The transformer has a large step-up turns ratio from primary to secondary. As a result, the swiftly falling and rising magnetic field in the primary induces a very large peak-to-peak voltage in the secondary. The peak-to-peak amplitude has to be high in order to drive the transducer; it can be as high as 1000 volts.

Battery life is almost as long as if the battery were sitting on a shelf losing energy as it ages. This is because current is drawn only momentarily as the button is pushed, connecting the battery and a tank circuit into the collector and secondary, respectively. A burst of audio energy is transmitted and the button released. The amount of energy actually drawn from a 9-volt mercury battery is an instantaneous 10 ma, resulting in little wear to the battery.

#### **No. 132: TRANSMITTER SUBSTITUTE TEST**

It is quite obvious, yet lots of times completely overlooked, that if a transmitter is suspect, and another identical "known good" transmitter is near at hand, the suspicion can be easily confirmed or denied. Yes, try the good transmitter and see if it performs. If it does, the suspect transmitter is definitely defective. When it doesn't, the suspect transmitter is exonerated and the trouble is probably in the receiver.

#### **No. 133: TRANSMITTER BATTERY TEST**

The best test for the 9-volt battery is replacement; however, this is not always possible immediately. Therefore, before taking a trip to purchase a new battery, test the battery quickly for output.

Do not test the battery out of the circuit. Leave it connected. Attach your voltmeter probes across the battery and take a reading without pressing a button. The battery should

read the full 9-volt rating. If it doesn't, it is defective, no matter what the reading is.

Leave the battery and voltmeter connected and start pressing buttons. Hold a button down and observe the reading. Under the load, the battery should read about seven or eight volts. If it reads lower, it is weak. The lower it reads the weaker it is. If it reads the full nine volts, the battery is probably good and the transmitter is defective. It is not drawing any current.

#### **No. 134: TRANSMITTER OUTPUT TEST**

The remote transmitter develops a large signal across its antenna or transducer, according to the type of output. Typically, in the remote transmitter we have been discussing a large peak-to-peak signal is applied across the transducer.

The signal can be measured with the p-p scale on the VTVM or directly displayed on the oscilloscope (Fig. 90). Simply attach the VTVM or scope across the transducer. A large multihundred volt peak-to-peak pulse as each button is pressed indicates the transmitter is producing an adequate signal. Little or no signal as the buttons are pressed indicates one or more of the circuits is not operating. If one button produces no signal, while all the rest do, then the circuit associated with the button is indicated as being defective.

#### **No. 135: TRANSDUCER TEST**

Again the best test for a transducer is substitution, but lacking that ability, another test is quite good. The transducer produces a high, beyond human hearing sound wave. However, the sound wave is not beyond the reproduction ability of the ordinary scope. The scope can actually "hear" transmitted frequencies in the air and cause a display.

When the transmitter has been proved good by the previous test and there is still no output, the transducer is suspect. Turn the vertical scope amplitude up to its highest point. Place the transmitter's output or transducer less than an inch away from the vertical input of the scope. Then, start pressing buttons.

If the transducer is good, the scope display will shoot up to an off-the-screen amplitude each time a button is depressed. When the scope does not respond, and all other parts of the transmitter are deemed good, the transducer is indicated as defective.

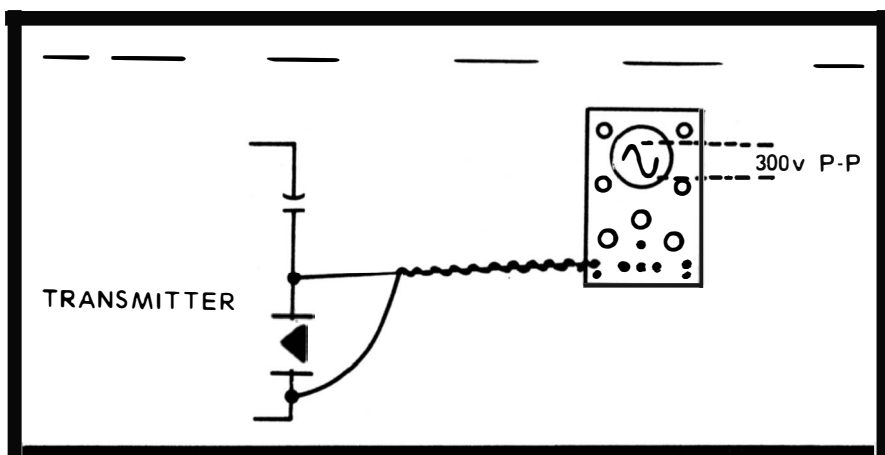

Fig. 90. The transmitted audio wave can be observed by connecting an oscilloscope across the transducer.

### No. 136: TRANSMITTER DEFECT TEST

When test No. 134 is performed and no output is produced across the transducer, a defect in the transmitter circuits is indicated. Connect the scope or VTVM p-p scale across the transducer and series capacitor. Then start pressing buttons. About twice as much p-p voltage should be present as is supposed to be across the transducer by itself. For instance, if the transducer voltage is supposed to be 300 volts p-p, then across the transducer and capacitor there should be 600 volts.

If the 300v isn't on the transducer but the 600v is present, the series capacitor is defective. Go no further; substitute a new 100-pf capacitor. Should the 300v not be across the transducer as the buttons are pressed and also absent across the two components, then the capacitor is good and the trouble is further on in the circuit. The transistor then becomes the prime suspect; therefore, a check of the other circuit components is in order.

### No. 137: TRANSMITTER ALIGNMENT

Transmitter alignment is easy. Each resonant circuit can be aligned with the separate trimmer capacitor in the tank circuit. Addition of and substitution of small amounts of capacity puts the frequency right on.

With either a known good transmitter or a 0-50 kHz audio generator, a scope pattern is obtained at the highest frequency

the transmitter is supposed to transmit. The alignment frequency is displayed on the scope by placing the generator or the known good transmitter near the scope input probe (Fig. 91). The known good transmitter can produce the scope display by pressing its highest frequency button. The generator emits a continuous wave.

The transmitter to be aligned is also placed near the scope input probe and its button pressed. With the two frequencies displayed, the trimmer is adjusted for zero beat. Then the lower frequency trimmers can also be adjusted in the same way by zero beating them against a frequency you know is correct. Always start out with the highest frequency and work down towards the lowest frequency.

### The Remote Control Receiver

The signals from the transmitter are picked up by an antenna or transducer in the receiver. This is identical to the way a radio works. The signal is amplified and further processed, then fed to a relay. In a radio the signal is fed to a speaker. That is the main difference between a remote control receiver and a radio receiver.

The relay opens or closes in accordance to the directions of the signal and turns on a motor (Fig. 92). The motor could be electric or a wound-up rubberband as in a model airplane (Fig. 93). The electric motor can turn a potentiometer, a tuner or a rudder on a boat or airplane. It can turn a steering wheel, apply brakes or push an accelerator.

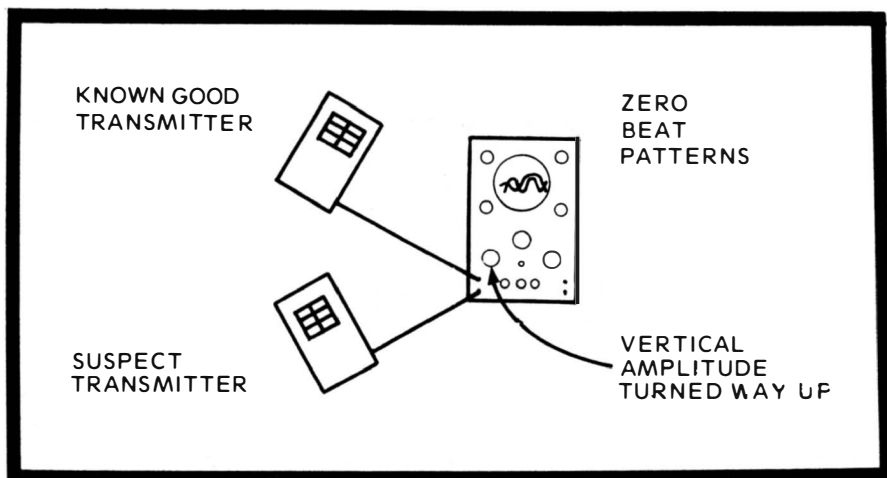

Fig. 91. The frequency of a transmitter can be checked by zero beating it with a second transmitter.

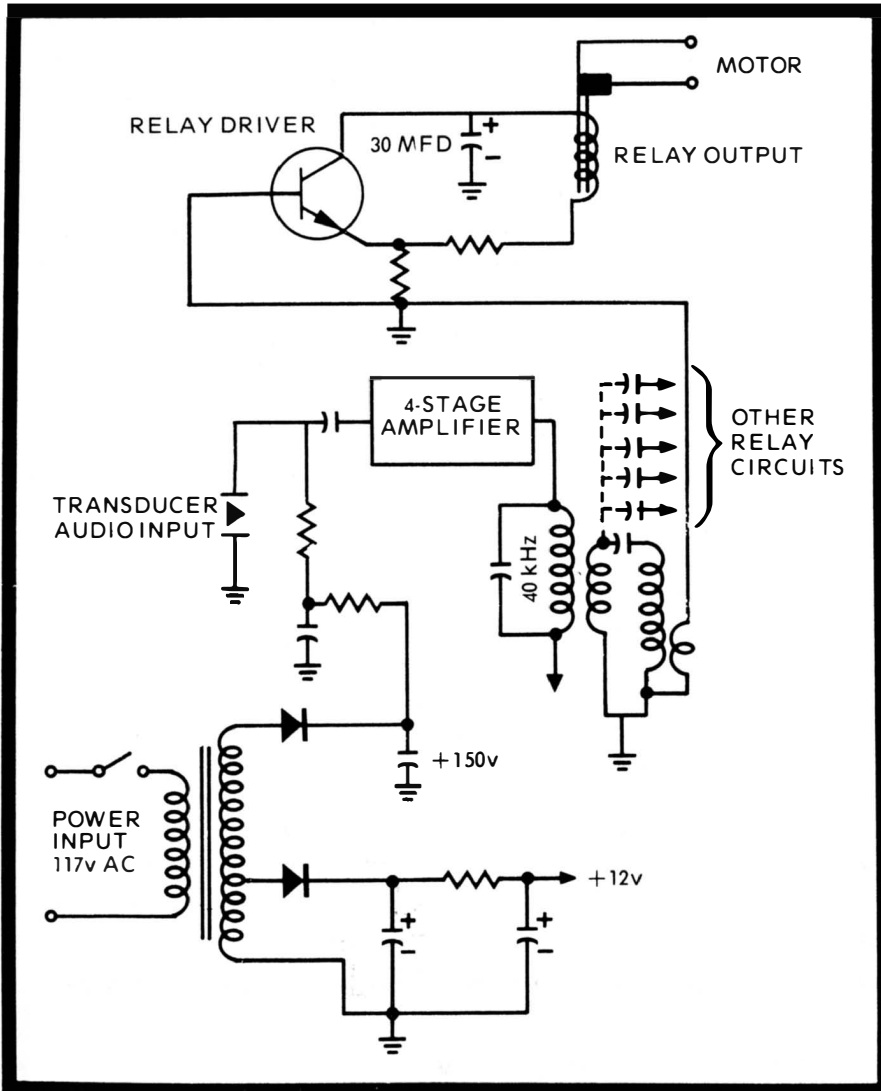

Fig. 92. Some remote control receivers are large, although the circuitry itself presents nothing unusual.

The rubberband motor, which is simply a stretched rubber band wound tautly many times, can unwind a few turns by a withdrawal of a brake as the relay is actuated. The uses of the remote control actuated relay is limited only by the imagination. Remote control units can range from the very simplest type of thing to enormous complexity.

The remote transmitter just discussed uses a different frequency for each function. In the above unit there were eight functions. What it all amounts to is eight separate trans-



missions all jammed into one small package. It's analogous to having eight small radio stations, each with a different frequency, and each being able to transmit independently of the other. There are also other ways to transmit a number of functions.

In an RF-type transmitter, a single frequency could be transmitted and eight separate tones could be used to modulate the RF. Each time a button is pressed a different tone would modulate the carrier. For instance, if the carrier wave is 27 MHz, it could be modulated with eight tones. Typical tone frequencies could be 1 kHz, 2 kHz, 3 kHz and so forth.

The receiver would be tuned to receive the single frequency of 27 MHz. The RF would be amplified and then a detector, just like in a radio, would reproduce the tones, which would be fed to the relay control circuits. The circuit tuned to a detected tone would respond and actuate the relay and turn on the motor.

In the same way, other means of transmission have been devised. A popular one is the transmission of square wave pulses, which are used to modulate a single RF frequency. A square wave is applied to the RF by turning the transmission off and on at high speeds. The pulse length is varied by the transmitter turn-on and turn-off rate. A long pulse is a dash

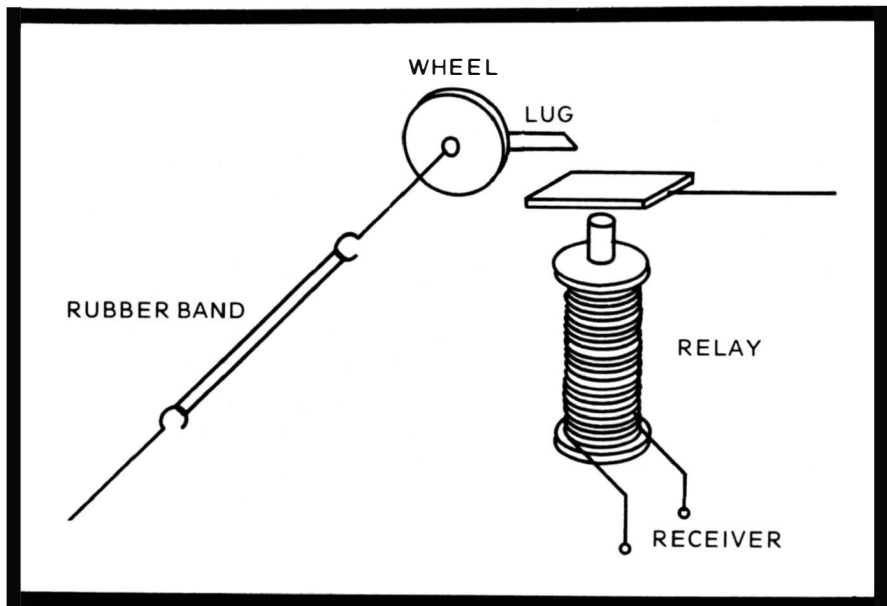

Fig. 93. A relay controlled rubberband motor can be slowly unwound by repeated movement of the relay.

and a short pulse is a dot in Morse code. You can talk to the remote control receiver with dots and dashes and it will perform a job to your wishes. Dots activate one relay, dashed another and an inbetween pulse still another.

In model airplanes, dots and dashes can make one relay move a rudder. Dots can cause the rudder to move to the left, dashes to the right and inbetween pulses keeps it at dead center. If you want further model airplane information, refer to a book on the subject.

Getting back to the remote control receiver, the 8-function receiver that matches with the transmitter discussed uses a transducer, identical to that found in the receiver, as a receiving device. Of course, an RF type receiver uses a tuned antenna circuit.

The transducer vibrates sympathetically with the transmitted sound waves. The B+ voltage applied to the transducer is approximately 150 volts DC. As the plates of the transducer vibrate, the capacity in the circuit is changed and the modulation is developed in the DC and transferred across a blocking capacitor into a broadband amplifier stage. The signal is amplified and then fed into three or four more such stages.

The eight frequencies range from 35 kHz to 46 kHz. A tuned transformer at the end of the amplifier stages, which resonate around the 40-kHz center frequency, picks off the amplified signal. The transformer then injects the signal into eight identical relay driver transistors. The coupling between the transformer and each transistor, however, is a highly selective series resonant link coupling for each frequency. There is a series capacitor and tuned transformer for each of the eight frequencies. The frequencies range from 35.5 kHz to 46 kHz at 1.5 kHz intervals.

As each frequency is received, it is passed on to the appropriate relay transistor and only to that transistor. They are NPN transistors and are kept at a normal turned-off state. A small positive voltage is taken from the power supply and applied to all of the emitters. The base is grounded through the secondary of the coupling transformer and stays at zero volts. The small positive voltage, therefore, gives the emitter-to-base junction a reverse bias. That way, the relays cannot be actuated by spurious pulses.

When the transmitter sends out a signal, part of it is applied to the oscillator transistor base. The positive half cycle causes a slight positive voltage on the base, and emitter-to-base current flows. This turns on the transistor and emitter-to-collector current flows. The 30-mfd filter in the collector

circuit discharges. With the transistor conducting, the relay coil energizes and closes the relay. This turns on the desired motor.

On the negative half cycle of the signal, the transistor turns off; however, the 30-mfd filter charges toward the source voltage from the power supply and keeps the relay coil energized. The relay holds at the closed position and the motor continues operating. The motor keeps working as long as the button is held down in the transmitter.

In the receiver, 117-volt house current can often be used for TV remote control, while the transmitter must depend on batteries. In mobile type remotes, battery operation has to be used for both transmitter and receiver. In some remote control systems the base station transmitter uses house current and the receivers are battery-operated. It's all according to the use.

Whatever the use, however, the power supply is designed in a particular way, using a simple full-wave rectifier circuit with a step-up power transformer. The 150-volt B+, as mentioned before, supplies only the transducer, while a 12-volt outlet is used for the transistors. The motors and relay coils also use the 117-volt input without any step-up or rectification.

### **Motors**

It is useful to use phase-shift synchronous motors, which can run backward and forward equally well. The direction depends on the way the AC voltage is applied to the motor windings (Fig. 94).

A resistor and capacitor is always installed in series with one of the motor windings to participate in the phase shifting. The resistor also damps any sparking that might tend to occur as the motor windings energize or de-energize quickly, causing a larger fast-changing magnetic field that produces instantaneous high voltages. The speed of the motor is kept at a low 10 RPM by a gear train. In color TV controls, a clutch arrangement is used so the rotor drops away when it is not being used. That way, during manual operation there are no gears to turn in addition to the color controls. The motors on various remote systems are large or small with all types of intricate mechanical designs.

### **Testing the Remote Control Receiver**

#### **No. 138: SIMPLE ALIGNMENT, REMOTE RECEIVER**

The alignment of the typical remote receiver described previously is quite easy. Using a known good transmitter or an

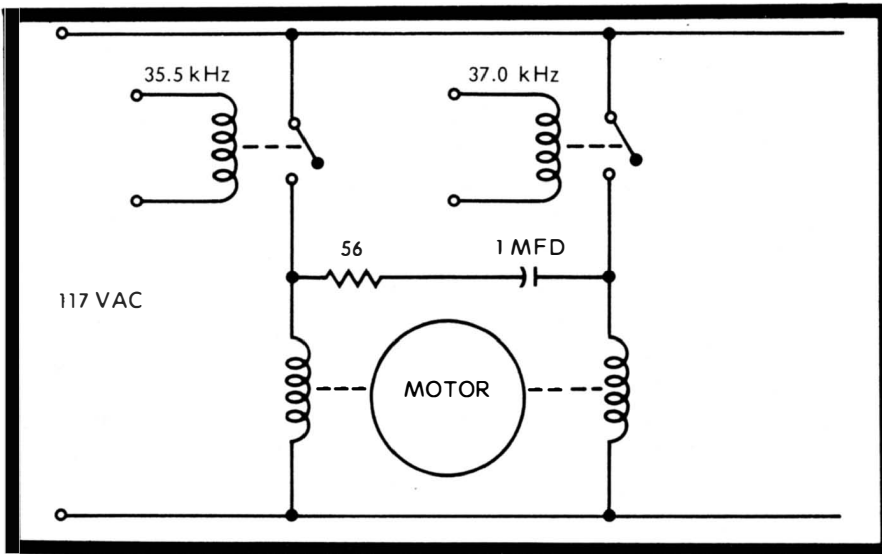

Fig. 94. A phase-shift synchronous motor circuit is so designed that the motor can be rotated both ways.

accurately calibrated audio generator, each function in the receiver is turned on, one after another.

A VTVM is attached across the common emitter resistor (Fig. 95) in each stage. During actuation by the transmitted signal, each input coil is touched up for maximum voltage on the VTVM. The amount of voltage is small and the low scale must be used. At exact resonance, the emitter bias voltage will be the highest.

#### No. 139: A MOTOR WON'T START

When one motor won't start, yet the rest of the functions are operating normally, the trouble is immediately isolated to the driver circuit that is supposed to actuate the motor or the motor itself. The master circuit that amplifies all of the signals is cleared since the other circuits are still operative.

A signal corresponding to the frequency of the dead circuit is applied to the base of the driver transistor. For example, it could be a 40-kHz tuned circuit. Accordingly, 40-kHz signal is applied to the base.

One of two things will happen. Either the relay and motor will be actuated, or not. If the motor does start, the trouble is isolated to the base input circuit, including the coupling capacitor and the tuned 40-kHz transformer. These two components should be tested, as well as the connection and other components in the base circuit if there are any.

Should the relay not be actuated with the injection of the 40-kHz base signal, either the transistor or one of the output components is the indicated troublemaker—the transistor, the collector filter capacitor, the relay or the motor itself. A one-by-one test of each is then in order.

#### No. 140: MOTOR STARTS BUT WON'T RUN UNLESS BUTTON IS HELD DOWN

Some motors are designed this way, but other motors are designed to run and complete a function before turning off. For instance, a motor might perform a tuning function. When you press the transmitter button, the motor starts running and continues until a station is tuned in. Then, the signal from the station cuts off the relay and the motor stops. When such a motor just turns on, and as you let up on the button it stops, there is a malfunction. There is usually a hold switch on the motor. Check the motor and its input components.

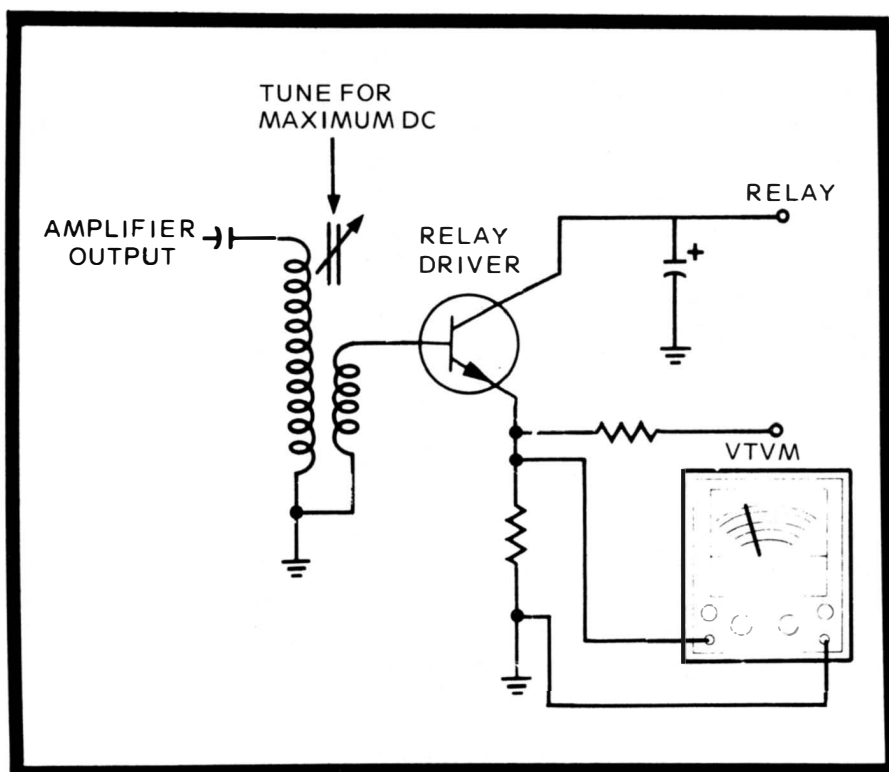

Fig. 95. This type of remote relay driver is easily aligned by connecting a VTVM across the emitter resistor and tuning for a peak reading.

#### **No. 141: MOTOR RUNS PAST DESIRED STOPS**

Some motors are designed to keep running until a certain spot is reached. For instance, a motor turning a VHF tuner is kept running until it arrives at a specific spot such as the VHF position. If the motor runs past the desired location, look for the wafer switch that controls that function and check it for opens or breaks.

#### **No. 142: MOTOR STOPS PERMATURELY**

An example of this is a VHF tuner that, instead of passing up unused channels, keeps stopping at every channel. There is a hold switch on the motor and a wafer switch that routes the control voltages to provide this service. They cause this problem when they are misadjusted or defective.

#### **No. 143: MOTOR WON'T GO BOTH WAYS**

Some functions of a remote receiver require that a motor go both ways. There is usually a separate button for each direction. Let's call the two functions up and down.

If the motor won't go both ways, but will go one way, then it is known that the motor is good, the motor's reversing switch is good, as well as the circuit function. For instance, if up is working and down isn't, the up circuit is good.

Run a jumper from the working circuit collector to the non-working collector. Then press the button. If the circuit works then, the relay is good but the transistor or its components are defective. Check them out. If it won't work, the relay is defective and needs repair or replacement.

#### **No. 144: NEITHER UP OR DOWN WORKS**

When both up and down are inoperative, there is a choice. Either both circuits have become defective at the same time, which is highly unlikely, or a circuit common to both is defective. Assuming a known good transmitter is being used, the wafer switch and connections become the only suspect.

#### **No. 145: MOTOR WON'T GO BOTH WAYS (ALTERNATE)**

If it is more convenient, this trouble can be isolated by injecting an appropriate signal into the base of the indicated circuit. If the motor then goes in the direction it hadn't been,

the base circuit is defective and the input capacitor and tuned transformer are the suspects.

When the motor still won't turn in the desired direction, the transistor, collector filter capacitor and relay have to be checked.

#### **No. 146: STEPPER RELAY WON'T WORK**

Stepper relays are important remote control components. With it, a control can be moved slowly step by step until a desired correction is achieved. This can be used in a model airplane to make slow careful adjustments so accurate steering, without oversteering, can be obtained. The common radio and television use is the gradual increase of volume.

When the transmitter button is pressed, a relay is actuated, which turns on a motor and advances a ratchet one step. In a model airplane, a relay is actuated, permitting a rubberband motor to turn a few times and then stop. Everytime the button is pressed, the relay allows one step. The test is similar to the ones we have discussed. An appropriate signal is applied to the base of the driver transistor.

If the relay actuates, the base circuit, the input capacitor and the tuned transformer are suspects. When the relay still doesn't actuate, the transistor, collector filter capacitor and relay itself should be checked.

#### **No. 147: DEAD REMOTE RECEIVER**

Assuming a known good transmitter is being used and none of the relays are being actuated at all, the trouble is indicated to be in the input transducer of the receiver, the receiver amplifier stages or the receiver power supply. The transducer is best tested by substitution. Once it is determined good, voltage readings should be taken in the power supply and amplifiers.

The +150-volt bias to the transducer should be checked; also the +15-volt power for the transistors. If one or both is missing, the power supply is the trouble. If they are both present, the power supply is deemed good and the amplifiers are next for investigation.

Test all of the amplifiers up to and including the amplifier output transformer which is linked to all the individual tuned transformers.

## Chapter 11

# Electronic Organs

Electronic organs have become big business and are found frequently in a goodly percentage of homes. A small electronic organ can produce sounds that at one time could be generated only by conventional organs many times the size and price. Tubes were used initially in electronic organs, but in recent years the transistor has taken over. Transistorized circuits are tiny and take up a small percentage of space.

Different manufacturers use radically different physical and electronic designs. It is not the purpose of this discussion to cover the field, but to explore a typical organ circuit and the means to test and align it.

**Oscillator:** All organ circuits are based around an oscillator. The oscillator reproduces electronically the sound of reeds or strings in non-electronic musical instruments. The electronic organ oscillator, in addition to its fundamental frequency, also generates many harmonics. These harmonics are desirable in order for the organ to simulate mechanical musical instruments.

The typical electronic organ uses one transistor in a blocking oscillator circuit configuration (Fig. 96). In the oscillator base circuit are twelve sets of series resistors. Each set of resistors is designed to make the oscillator run at a frequency corresponding to the twelve keys in an octave.

Large keyboard organs have a separate oscillator for each octave, or use the same oscillator and simply have more series resistor sets for the additional keys. Each resistor set can have one fixed resistor and one potentiometer. The pot is used for accurate tune-up.

The playing keys are actually specially designed switches. As the key is depressed, it closes the circuit on one of the series set of resistors. A spring on the key pushes it back open as the hand pressure on it is relieved.

The oscillator transistor is biased off by returning the base through a master potentiometer to the chassis ground. As a key is pressed, the set of series resistors is shunted across the master pot and the resultant change in bias turns on the



transistor. The oscillator starts and produces the called for tone. Releasing the key places the master pot back into the circuit, reverse bias is developed and the oscillator quits. When another key is depressed, the same sequence occurs, except that another oscillator frequency is generated and thus another note.

**Amplifier:** After the note is generated, it must be amplified and fed to a speaker system. For pleasant music to be

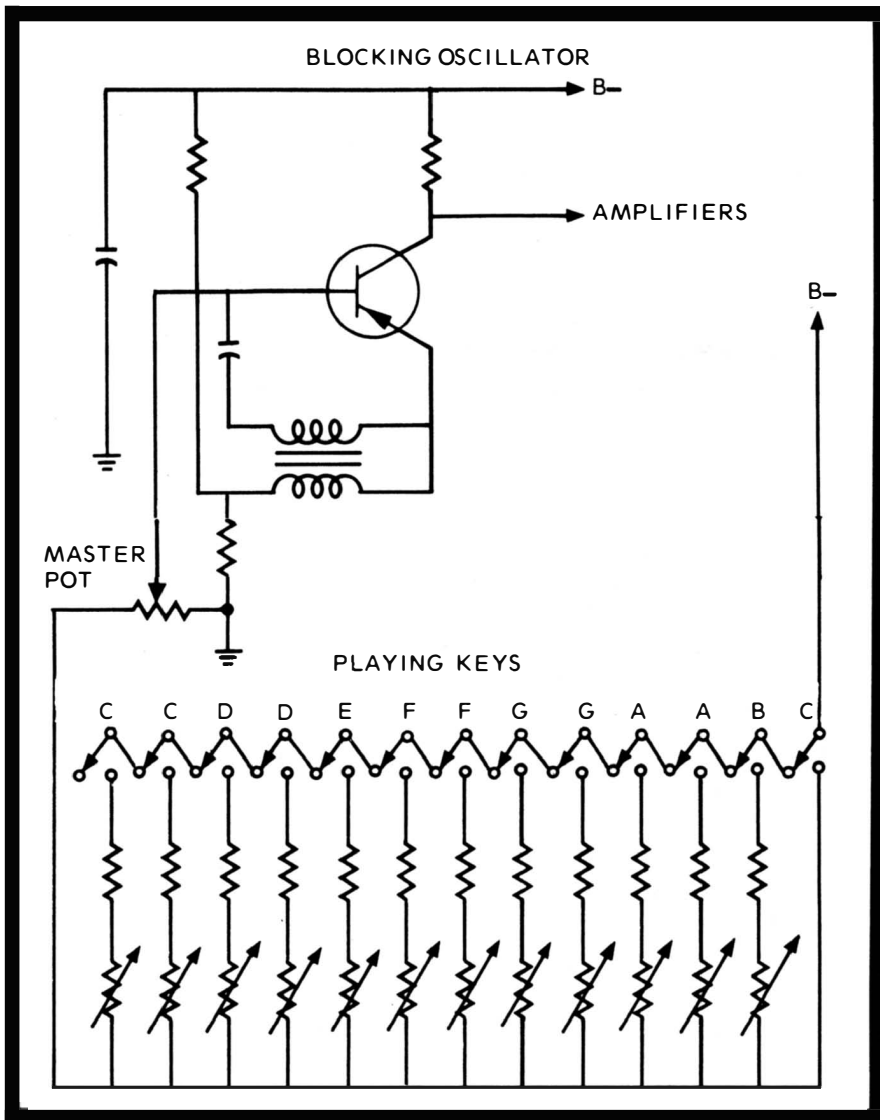

Fig. 96. A typical organ circuit is a simple blocking oscillator. The playing keys vary the base bias as they are pressed.

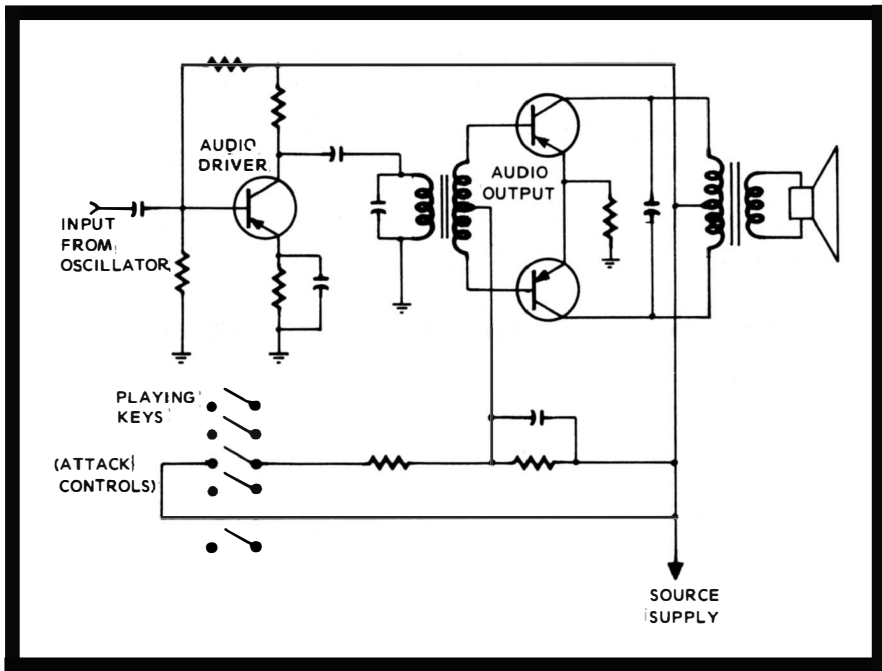

Fig. 97. Attack controls are attached to the playing keys and control a simple pushpull amplifier.

heard, the notes should blend together instead of turning on and off quickly, producing a staccato effect. The blending of the notes is called the “attack” and an attack type amplifier must be used.

The attack amplifier (Fig. 97), also has to be turned on and off with each key. The switch for the amplifier is attached in such a way that it does not shut off simultaneously with the oscillator switch but slightly afterwards. That way the attack effect is helped along.

An attack amplifier looks quite like any audio amplifier. Typically, it can be a push-pull type. The input from the oscillator is fed to a driver transistor. The output of the driver is sent to the primary of a push-pull type transformer. Both ends of the transformer are attached directly to the bases of the twin transistors. The center tap of the transformer passes through an RC network to the attack control switches. There is one switch for each note, which is closed when the musician depresses a key. The key closes the oscillator and amplifier together. The time constant of the RC network determines the amount of attack.

The push-pull transistors are biased off until the attack switch is closed. Then they turn on and stay on until the switch

is reopened and the RC network permits the bias to gradually become reversed and turn off the transistors.

The speaker system is carefully designed for the organ. When you replace a speaker, it's best to use an identical unit. Many of the speakers are inexpensive and the tendency during replacement is to use a better, more expensive speaker. Should you do that and the better speaker sounds bad, it's because the less expensive speaker was designed for that organ. You have upset the delicate tonal qualities with the better speaker. Before doing anything else, try the correct speaker. It probably will prove better.

#### **No. 148: ORGAN TUNE UP**

As an organ ages, the electronic components age, and instead of a pure note emanating from the speaker, the note is out of tune. Each note can be tuned by a variable resistor. Changing the setting of the resistor changes the oscillator frequency slightly and sets the note that is heard (Fig. 96). The manufacturer's service notes will pinpoint the location of each variable resistor. They can be set by an experienced musician for exact tone. Some of the service notes provide procedures for the average organ owner to tune his own organ.

#### **No. 149: WHEN ONE NOTE DOESN'T WORK**

If you are playing the organ and discover that one of the notes is inoperative, locate the oscillator circuit. In the oscillator there are as previously described a separate series 2-resistor setup for each note. One resistor is fixed and the other is variable. Also in that specific circuit leg is the switch attached to the playing key. They are the three suspects that can cause the loss of the one note. Test them one at a time. Replace the bad component with an exact replacement. Then retune the note for the correct tone.

#### **No. 150: TESTING A CIRCUIT WITHOUT SERVICE NOTES**

Electronic organs, like any other electronic gear, are easier to troubleshoot if you have the manufacturer's service manual. However, unlike most consumer type gear, organs can also be easily tested without the service notes. That's because the circuitry in an organ is repeated over and over and over again.

When a particular circuit seems to not be working properly, while other circuits just like it are, try this: Make a

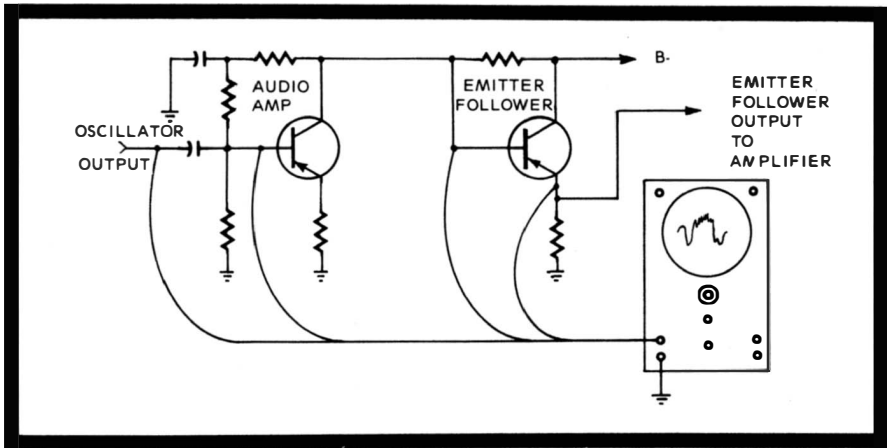

Fig. 98. A scope can be used to trace through the organ circuitry, since it only has to follow the oscillator signal.

sketch of the circuit, then with the aid of an identical circuit that is operating, take voltage readings at test points like transistor junctions. Then, compare the voltages you've obtained at the known good test points, with what is present at the defective circuit test points. By comparing the two sets of readings, you can quickly obtain voltage clues.

#### No. 151: SIGNAL TRACING ORGAN CIRCUITS

When a complete keyboard quits, the oscilloscope is very useful. All the signals generated and passed through the circuits are in the audio range. Using a scope with internal horizontal sweep, the vertical input will display what's going on inside the circuit.

The first test point to check is the output of the oscillator (Fig. 98). One of two displays will be seen. One is the audio signal developed by the oscillator. If it is present at the oscillator output the oscillator is cleared as the troublemaker. The amplifier is indicated next. Should there be no oscillator output, the oscillator is defective, and you can find the reason by checking back into the circuit.

A typical oscillator output uses an emitter-follower circuit to deliver the signal to the amplifier. At the emitter output test point, the fundamental frequency can be picked off. When the fundamental is not present, the next test point is the collector of the preceding transistor amplifier. If the signal is displayed at that point, the emitter-follower circuit is suspect. Should the frequency still not appear, the base of the amplifier is the next

logical test point. The same rules apply. No display clears the amplifier. A good display at the base indicates a defective amplifier circuit.

#### **No. 152: TESTING THE OSCILLATOR FREQUENCY**

When there is still no display, it could mean trouble in the oscillator frequency divider which contains a number of resistors, capacitors and a switch. The scope probe is touched on the collector of the oscillator. If a signal is present, the oscillator is running.

The oscillator frequency itself can be confusing. Some organs use an oscillator that runs at the fundamental frequency which involves a low bass note at about 250 Hz. When the scope is attached to the collector and the lowest key is held down, a 250-Hz signal would be displayed. However, in other organs the oscillator runs at multiples of the fundamental frequency; for instance, six times the fundamental, which in this case would be 1500 Hz. On these organs the scope should display the 1500-Hz frequency when the lowest note key is held down. If no display is produced during the time a key is held down, the oscillator is not running and the oscillator circuit should be examined by voltage and resistance tests.

#### **No. 153: TESTING DIVIDER CIRCUITS**

For these tests you should have the schematic of the organ. As mentioned previously, some organs use an oscillator running at multiples of the fundamental frequency; for instance,  $6f$  or six times the fundamental. When there is a  $6f$  oscillator, in order to end up with the fundamental frequency  $f$ , there must be divider circuits in the organ.

The reason for the multiplier oscillator and then the divider circuits is so the organ can generate strong second and third harmonics, which when mixed with the fundamental produces realistic musical instrument imitations. All types of circuits are found in actual use. The schematic of the individual organ provides the actual functions.

The scope tells all. Set the horizontal internal sweep for the fundamental as produced in the emitter follower. Then touch down on the divider circuits; the binary divider divides the oscillator frequency by two. If the oscillator is  $6f$ , the output of the binary divider should display  $3f$ . The scope display should show three sets of fundamentals as the internal sweep runs at the fundamental. A ternary divider circuit divides the oscillator by three. This makes the  $6f$  into  $2f$ .

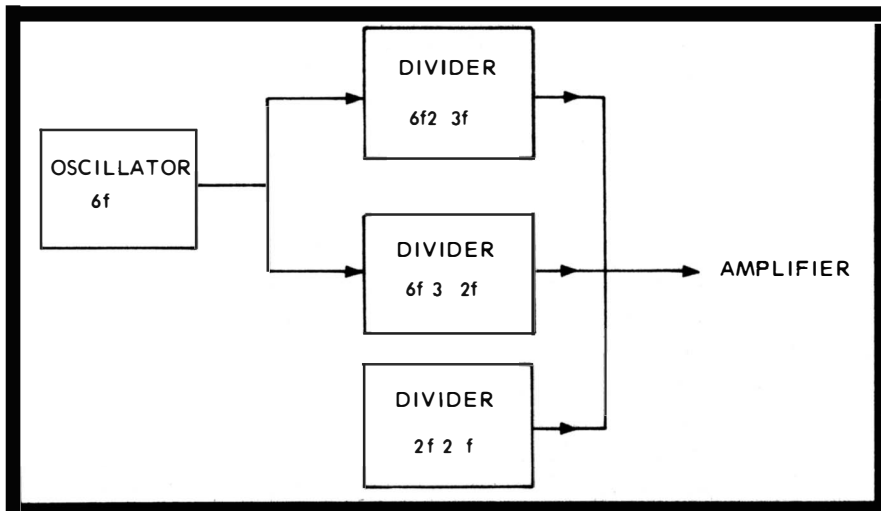

Fig. 99. Frequency divider circuits are used to produce the various harmonic tones needed for music.

Therefore, the output of any ternary divider should display two sets of fundamentals on the scope.

#### No. 154: BLOCK DIAGRAM SIGNAL TRACING

Working your way through fundamental, binary, ternary divider and multiplier circuits can be a confusing experience. But most of the confusion can be eliminated if, once you discover it is necessary to ascertain the actual output frequency numbers, multiples and divisions, you quickly draw a block diagram similar to that in Fig. 99. For instance, suppose you see from the schematic that there are three outputs from an initial  $6f$  oscillator. The three outputs are  $f$ ,  $2f$  and  $3f$ .

Then you see that the  $f$  is finally produced by first dividing the  $6f$  by three in a ternary divider, which produces  $2f$ . Then the  $2f$  is made into  $f$  by passing the  $2f$  through a binary divider. Meanwhile, the  $2f$  from the ternary is utilized as another direct output. Then, finally, you analyze that the  $3f$  is obtained individually by-passing the  $6f$  through another binary divider. Even though the mathematics is elementary, confusion can result from the maze. A block diagram reduces the confusion and guides you to the correct analysis.

#### No. 155: SIGNAL INJECTION TESTS

While scope signal tracing is an adequate technique, an alternate procedure, equally as good for localizing trouble, is

signal injection. With an audio generator tuned to a note about or under 1 kHz, injections can be made.

The best place to start is the center point between the amplifier and the oscillator circuit output. The speaker will provide the output. If the injection produces a good tone, the amplifier and speaker outputs are good and the oscillator area is suspect. When the injection produces no tone, the oscillator, by elimination, is cleared and the amplifier and speaker circuits are suspect.

The indicated trouble area can be further narrowed down by starting at the center. A test signal should be injected at the appropriate test points one at a time such as the base and collector or control grid and plate. When injecting a signal through the amplifier, as soon as a note is heard, the defective circuit has just been passed over.

#### No. 156: FINDING SOURCE OF OSCILLATION

The binary and ternary divider circuits are usually designed in such a way that they resemble a multivibrator circuit (Fig. 100). The main difference between them and such an oscillator is the bias on the transistors. On occasion, the bias will be

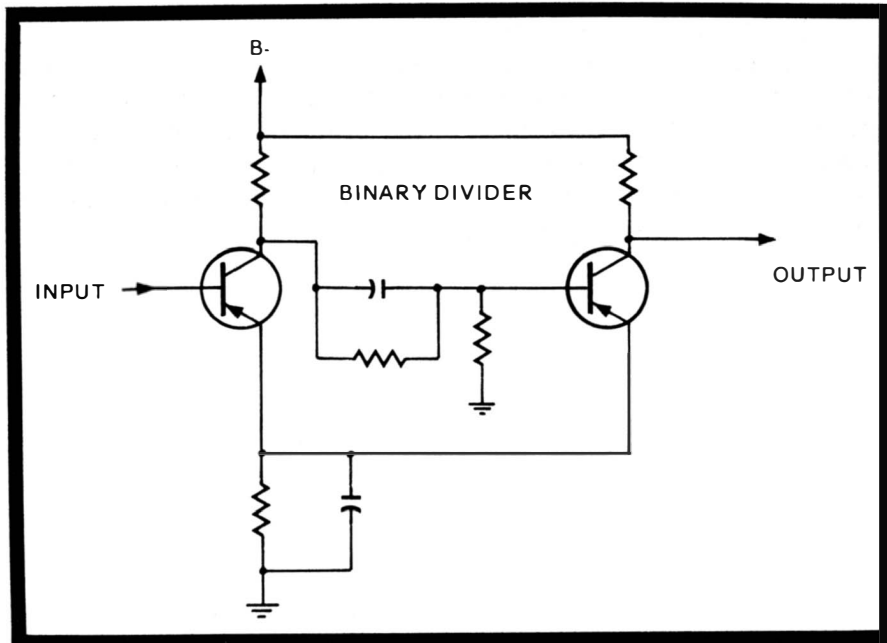

Fig. 100. A binary frequency divider changes the oscillator output to one half of its operating frequency.

lowered and the stages, when energized, go into oscillation. When the organ starts making noises, suspect these stages immediately and test the bias. Chances are good you'll find the bias has decreased and is sending the stage into oscillation.

**No. 157: INCORRECT MUSICAL NOTES—NOT  
ENOUGH BIAS ON DIVIDER CIRCUITS**

This is a companion to the above trouble. Too little bias, instead of causing the stage to oscillate, causes the stage to not do any dividing. Instead of amplifying the  $6f$  output from the oscillator, the divider stage is triggered into oscillation and it produces an output frequency of  $6f$ . Then when it mixes with the other two outputs, the resultant frequency is all wrong.

**No. 158: INCORRECT MUSICAL NOTES—TOO  
MUCH BIAS ON DIVIDER CIRCUITS**

Following along the same line of reasoning, too much bias on the ternary divider turns off the stage. Since this stage in this circuit configuration produces the fundamental as well as  $2f$ , they both will be missing. Only  $3f$  is produced with the resultant incorrect sounding music. Incorrect bias on the stages, when suspected by the symptoms, is easily localized by signal injection or signal tracing and then pinpointed by voltage and resistance tests.

Organs are quite simple mechanisms in comparison to home electronic equipment such as color TV. If you are an organ owner, then in addition to the electronic understanding, even more symptoms will be obvious to you, during testing, from the sound of your instrument. With long use of an organ, you can almost tell what has gone wrong from the sound of it.



## Chapter 12

# Electronic Vocal Chords

A wonderful device that is finding increasing use is an electronic vocal chord device for individuals who have either lost vocal chords through surgery or had them paralyzed by a stroke or other type of medical problem. Amazingly, a person so stricken adapts quickly to the electronic voice and the instruments are finding wide use. Not wide enough for electronic repair stations to really concentrate on them, but wide enough to present a trying experience for a person who is dependent on one and has it go out on him. Fortunately, the circuits are simple and a discussion of the testing techniques should help locate a defect.

### No. 159: POWER SUPPLY TEST—DC

Failure in an electronic vocal chord unit is most often due to power supply problems. In a Bell Laboratories circuit (Fig. 101), there is a single-ended output transistor that is attached directly to a transducer. A 10-volt battery puts a negative voltage on the collector through the transducer. The transistor (a PNP) drives the transducer and battery drain is high.

When the user is in a fixed location such as behind a desk at work, or in bed as a patient, the battery can be dispensed with and a small converter can be used. The converter changes the 117-volt wall outlet current into the plus and minus 10 volts DC needed to power the unit.

The battery voltage can be tested by placing a 100-ohm resistor across the battery before reading it. Even with the large load, a good battery will maintain a near 10-volt output. If the battery voltage drops with the load, the battery should be discarded. In fact, if in doubt discard the old battery.

### How the EVC Works

The Bell Lab circuit uses a finger-operated combination switch-variable resistor unit. The user presses the switch on,

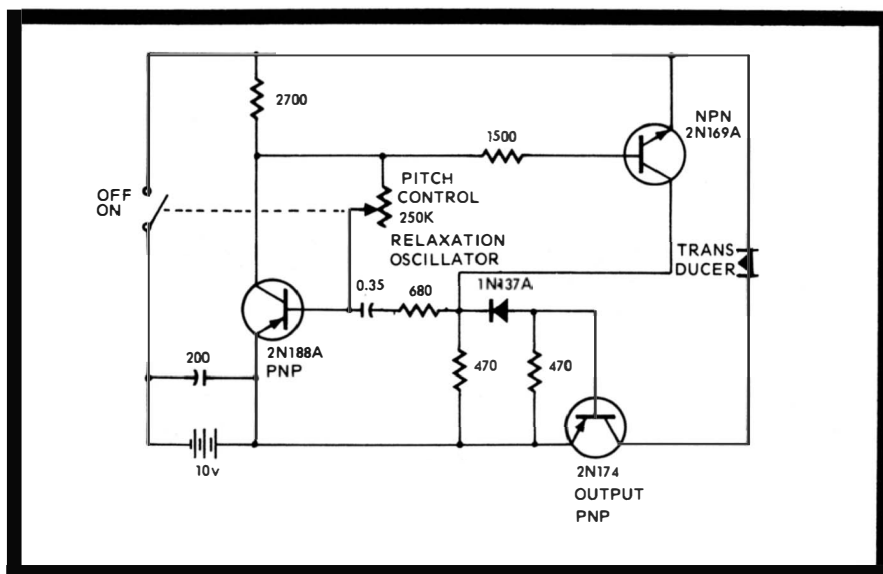

Fig. 101. Electronic vocal chords have been devised using this Bell Lab oscillator circuit and transducer.

and with variable pressure from his finger can control the pitch of his voice to sound as natural as possible.

The idea of the unit to supply to the throat a sound that emanates from the transducer (like the one on the inside of the telephone earpiece) to the throat cavity, tongue, mouth, teeth and lips. Only the sound is gone from the stricken individual. He can still form all the words in his vocabulary with the other parts of the anatomy.

The transducer is held against the throat. The on-off switch is pressed and a negative voltage is applied to one transistor, a PNP, while a positive voltage is applied to an NPN. The two transistors form a relaxation oscillator. The frequency of the oscillator can be varied with a resistor between the two bases. This is the pitch control in tandem with the off-on switch.

The output is a negative-going pulse. The frequency can be changed from about 100 to 200 Hz for men and 200 to 400 Hz for women. The oscillator output is fed to the audio output stage and then to the transducer. The transducer has a steady 10-volt DC supply across it. The oscillations modulate the DC.

The transducer plates move in accordance to the electronic audio, and the audio frequency is transferred into the throat cavity. The user then mouths the words and the sound emanates from him.

### **No. 160: SIGNAL INJECTING A DEAD EVC**

When the EVC goes dead and the power supply is judged satisfactory, a quick way to isolate the trouble is with an audio generator. Take a low-audio pulse (under 1000 Hz) and inject it at the base of the audio output transistor, with the off-on switch on. If the note can be heard from the transducer, the audio output stage is good and the relaxation oscillator circuit is defective. Should the notes not be heard, the transducer or output transistor is defective.

### **No. 161: SPURIOUS PULSE ELIMINATION**

The oscillator produces a pulse in the low audio range. The pulse leaves the oscillator at the junction of the NPN collector and the cathode of the diode. The diode is held at a high reverse bias between pulses and thus isolates the output stage from the oscillator between pulses. The isolation enhances stabilization and no spurious oscillations are produced from possible feedback from the output to the oscillator.

Should unwanted noises, buzzing or squealing start in a user's voice, it could be caused by breakdown of this diode. Measure the diode's resistance in both directions. If the resistance is lowered for reverse bias, the diode could be at fault. Another reason for this trouble could be lowered reverse bias in the emitter-base or collector-base junctions of the output transistor. Analyze the transistor, too.

### **No. 162: SIGNAL TRACING THE DEAD EVC**

The oscillator pulse in an EVC can be observed throughout the unit. With a scope or the peak-to-peak scale of the VTVM, the voltage present at the test points at collectors, emitters and bases can be analyzed. In the collector of the output, a pulse should be observed with a high peak-to-peak voltage, enough to drive the transducer, and a frequency for the man or woman patient as described before.

At the collector of the NPN oscillator transistor, the same pulse should be present, negative-going, but lower in voltage than the output, since it hasn't been amplified. A missing pulse, with the off-on switch on, at either test point indicates trouble in the transistor circuit under test.

### **No. 163: PITCH CONTROL TEST**

The pitch control is a variable resistor placed between the two oscillator bases. The NPN transistor is attached to the battery bias through a 1500-ohm fixed resistor. The PNP transistor is attached to battery bias through the variable resistor. As the pitch control is varied, it changes the amount of bias on the PNP. This, in turn, varies the PNP collector current which changes the bias on the NPN. Therefore, the oscillator frequency changes as the pitch control is varied.

Attach a scope probe to the cathode of the diode and observe the frequency of the scope display. A good working pitch control will vary the frequency about a 100 or so Hertz in either direction.

### **No. 164: PULSE WIDTH TEST**

The feedback in the oscillator determines the width of the oscillator pulse. The pulse width can be varied by adjustment of the blocking capacitor and series resistor from the collector of the NPN to the base of the PNP. A compromise has to be formed to produce a pulse as high as possible for strong audio output with a narrow pulse so the transistors will actually draw current during as small an interval as possible.

The pulse can be observed on the scope. Pulse width can be adjusted with various values of the series capacitor and resistor. Due to the low frequencies used, high sound levels are needed from the transducer.

### **No. 165: PERMISSIBLE CURRENT DRAIN TEST**

Since such large power needs are required, the current drain in a battery portable unit must be tested to be sure a powerful enough battery is being used. Attach an ammeter in series with the off-on switch using a fresh battery. Then turn on the unit and take a reading.

Suppose you find the EVC is drawing 35 milliamps. A good rule of thumb is not to use a battery with a maximum rating under ten times the current drain. That means the battery should have no less than a 350 ma per hour rating. This should give at least 10 hours and possibly as much as 15 hours of continuous operation. That means weeks and weeks of actual conversation. If the user is judicious in the use and keeps one finger on the button, letting the unit turn off between speaking segments, while he is listening, the battery will last a long time.

Since the unit is transistorized and a negligible amount of heat is generated, the reaction of the unit is instantaneous. The fact that the unit provides a man's voice tones, a frequency between 100-200 Hz, or a woman's voice tones, 200 to 400-Hz, has no bearing on current drain. It draws exactly the same amount of current in either case.

## Chapter 13

# Intercom Systems

A typical home intercom system is a relatively simple electronic gadget in comparison to other items like radio and TV. Any radios that are included in such systems are additional to the actual intercom, which is an ordinary audio amplifier.

The intercom itself only need pass the same range of frequencies as a telephone, about 250 to 2500 Hz. As a result, speakers and transformers are small and inexpensive. Reliability and quality are easily obtained.

In transistorized units, the amplifiers are usually operated in Class B, which means very little current is drawn from the power supply except when speech is being amplified. Such intercoms can be left on continuously with little cost per month.

There are still many vacuum tube intercoms around, but no new intercoms are being built with tubes. Vacuum tube systems should be shut off at the end of the day, due to heater operating cost and the lowered component life due to heat.

An intercom is a simple audio amplifier and an elaborate switching arrangement. The same amplifier is used to power the base unit and one or more remotes. Switching gets more and more elaborate as remotes are added and becomes extraordinarily complex as other functions are added, such as radios and paging systems.

The simple intercom with one remote is an audio amplifier, switches and two speakers (Fig. 102). The base station contains the amplifier and one speaker and the remote is simply a speaker. There are switches in both the base station and remote. The speakers are used as both microphone and speaker. When talking, the base speaker is switched into the input of the amplifier. When listening, the speaker is switched into the output of the amplifier.

While the base station speaker is being used as a microphone, the remote speaker is switched into the output. Then when the main speaker is being used as a speaker, the remote is switched into the input and is used as a microphone.

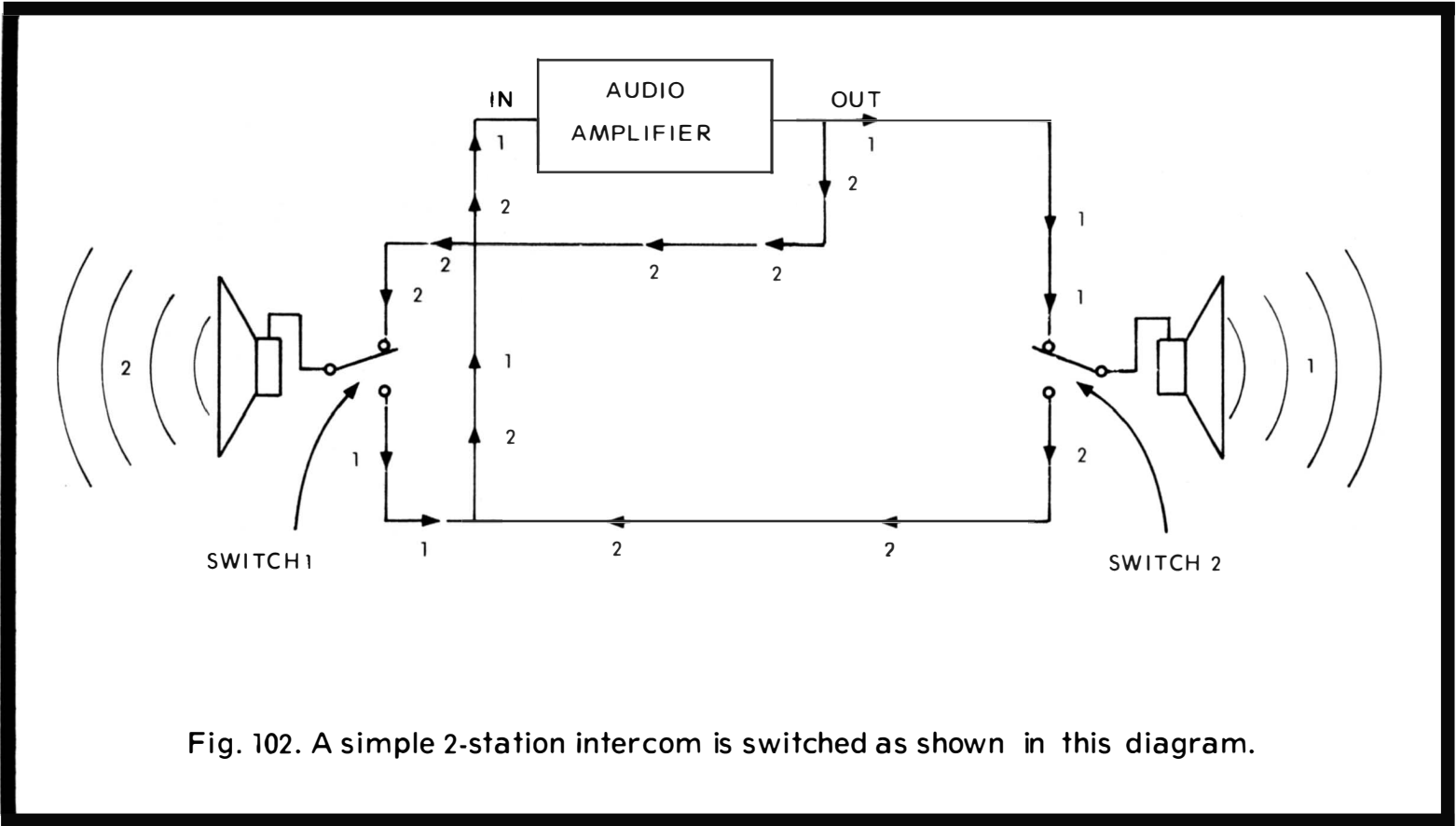

Fig. 102. A simple 2-station intercom is switched as shown in this diagram.

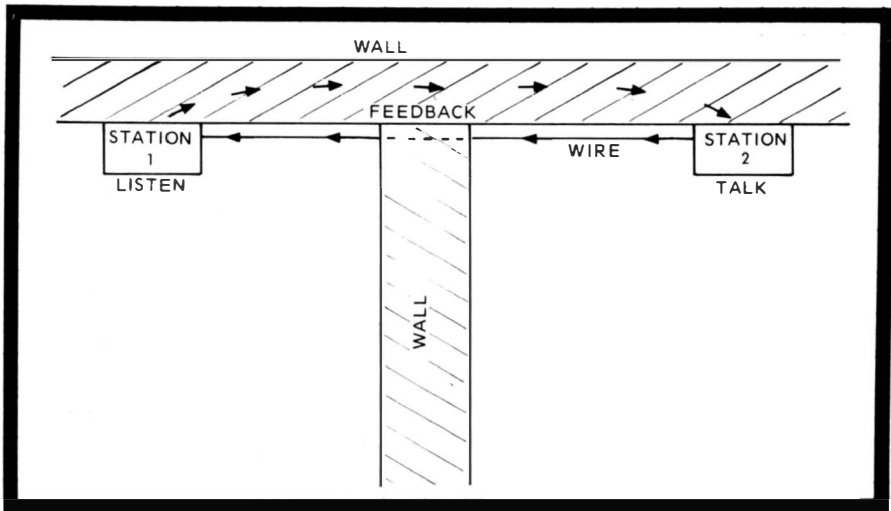

Fig. 103. During intercom installation, stay away from common walls to avoid unwanted feedback.

#### No. 166: ACOUSTIC FEEDBACK TEST

Most people interested in electronics are familiar with acoustic feedback. If you are talking on a microphone to an audience in front of you, some of the audio can bounce off the walls re-enter the mike, producing a howl. In intercom systems, a deceptive type of feedback is common.

If everytime you talk into the intercom a howl is heard, yet the remote is in another room, where is the feedback coming from? Usually, through the walls (Fig. 103). If you have a common wall between the base station and the remote, your voice will come out of the remote and be transmitted through the solid wall, back into the base station microphone. The annoying howl will result. Yet you do not hear the feedback at all.

To test whether the howl is really feedback, attach extra wire to the remote and take it into another room. If the howl disappears, then it was acoustic feedback. Try repositioning the remote at different sites in the room you want it in. Also try lower audio volume levels.

#### No. 167: SIGNAL INJECTION TESTS—SPEAKERS

The typical transistor intercom amplifier produces under a watt of power and can be a simple 4-transistor circuit (Fig.



104) where an audio amplifier supplies, by capacitance coupling, a driver stage. The driver then powers a pair of output transistors in push-pull.

When a transistor amplifier goes dead and the power supply is operating, the actual transistor circuit that is causing the problem is easily pinpointed. A 1-kHz note from an audio generator is injected into various test points and the results observed.

When the note is injected into the collector of either output transistor and the 1-kHz tone is heard in one of the speakers (the station or the remote), it means the speaker is good. Both speakers are cleared by switching them into the output one at a time.

Should one of the speakers not respond to the note as it is switched into the output, it is indicated as defective. If both speakers do not respond, then the audio output transformer is the suspected troublemaker. The note will be at a low volume since there is no amplification at this point.

#### **No. 168: SIGNAL INJECTION TESTS—AMPLIFIER**

The amplifier can be quickly examined with the same 1-kHz note. Inject it at the various test points such as the collector and base of the driver and audio amplifier. If you inject the note at the collector of the driver and the note is heard, the pushpull stage is good and the trouble is in the driver or amplifier. No note means the pushpull stage contains the trouble. The note will be heard louder from this test point, since the push-pull stage is able to amplify it.

If you inject the note at the collector of the audio amplifier and it is heard from the speaker, the driver stage is cleared and the amplifier is indicated. No note here means a bad driver stage. Should you get all the way back to the base of the audio amplifier and still hear a clear note, the transistors are all good and the problem is in the input device. No note at the base test point means a defective audio amplifier stage.

#### **No. 169: SIGNAL TRACING TESTS**

Signal tracing is not as useful a test in intercoms as signal injection. That's because there is no audio passing through the stages during normal operation. You can signal trace, however, if you desire. You can use an audio generator as an audio source and trace the signal with an oscilloscope. The addition of the extra piece of equipment compared to the signal injection technique is time consuming. If there is a

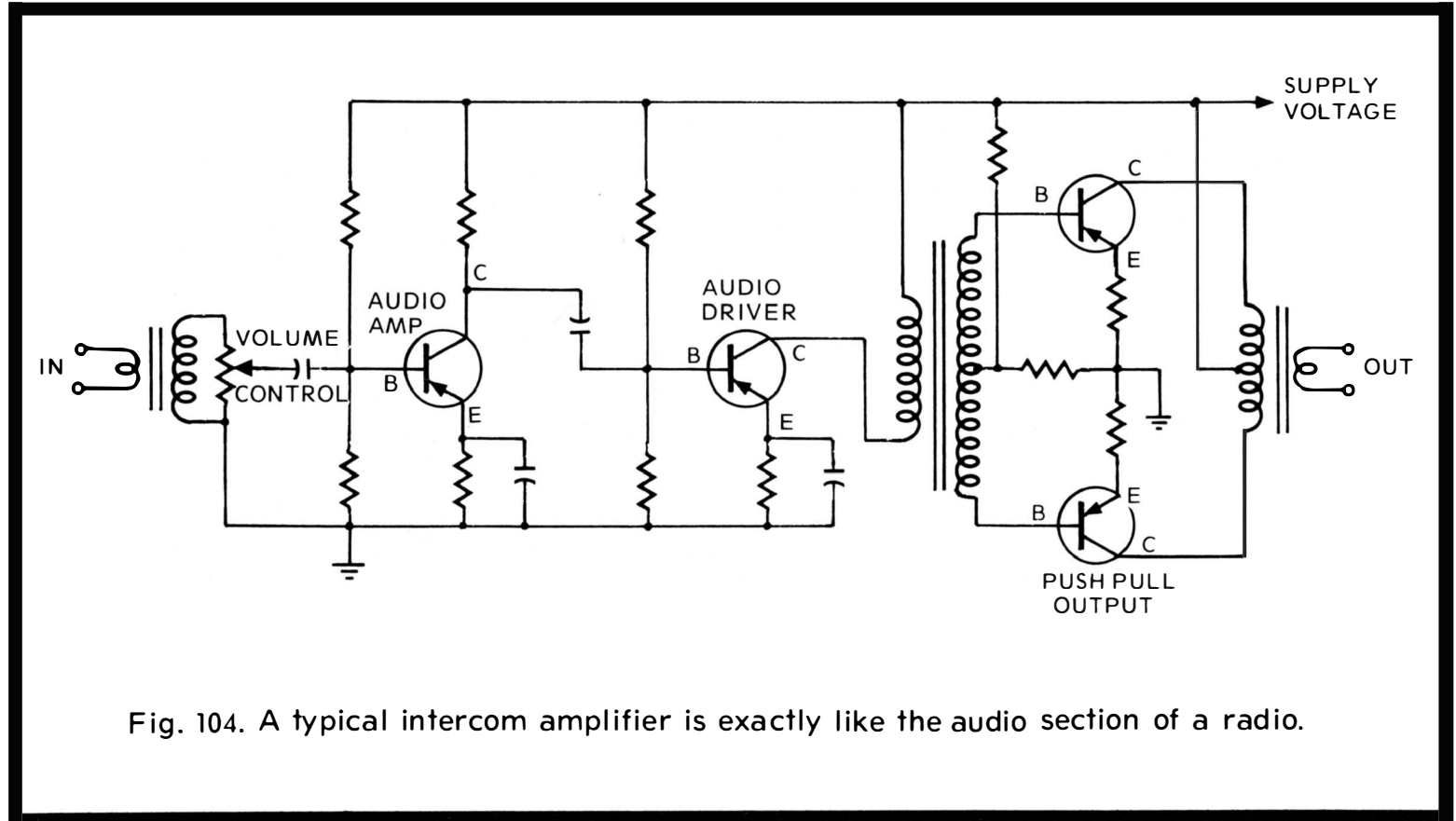

Fig. 104. A typical intercom amplifier is exactly like the audio section of a radio.

radio in the intercom, you can use it as a source of audio. Also, you could speak into the system and hold the talk switch down. Then trace through with the scope.

Should you decide to signal trace, the same test points are useful; namely, the transistor bases and collectors. Simply touch the scope to each point and look for an audio display on the scope. As soon as the display is lost, you have passed over the defective circuit.

#### **No. 170: OUTPUT OSCILLATION TEST—TUBE**

In the vacuum tube intercom amplifier, a very common problem is oscillation in the output stage. A loud high-pitched whine starts from the unit and continues, becoming a severe annoyance. The oscillation is due to capacitance feedback from the plate to the control grid of the output tube and capacitance feedback of the long lines between stations. A series control grid resistor, typically between 10 and 20K, is placed in the circuit to dampen the oscillation. Even with the resistor, as the output tube ages the feedback increases and the whining occurs.

You can test for the amount of resistance you need in series to successfully dampen the oscillation. Unhook one side of the resistor, take a 50K potentiometer and substitute it for the resistor, using the center tap and one end of the potentiometer (Fig. 105).

With the pot installed and the amplifier on, vary the resistance. As the potentiometer forms a resistance near zero, the oscillations will begin. Then you rotate the pot the other way, as more resistance is inserted into the control grid, the oscillations will stop as a result of the resistance dampening. However, the more resistance you install in series, the lower the amplifier output will be, because the higher resistance attenuates the signal.

Find a setting on the pot where the oscillations are eliminated and there is still a satisfactory sound level coming from the amplifier. You can either leave the pot in the circuit, or install a fixed resistor of a value corresponding to the setting of the potentiometer.

#### **No. 171: CABLE POWER LOSS TEST—PERCENTAGE**

In most inexpensive intercom systems, the output transformer has an impedance of 4 ohms and matches a speaker of

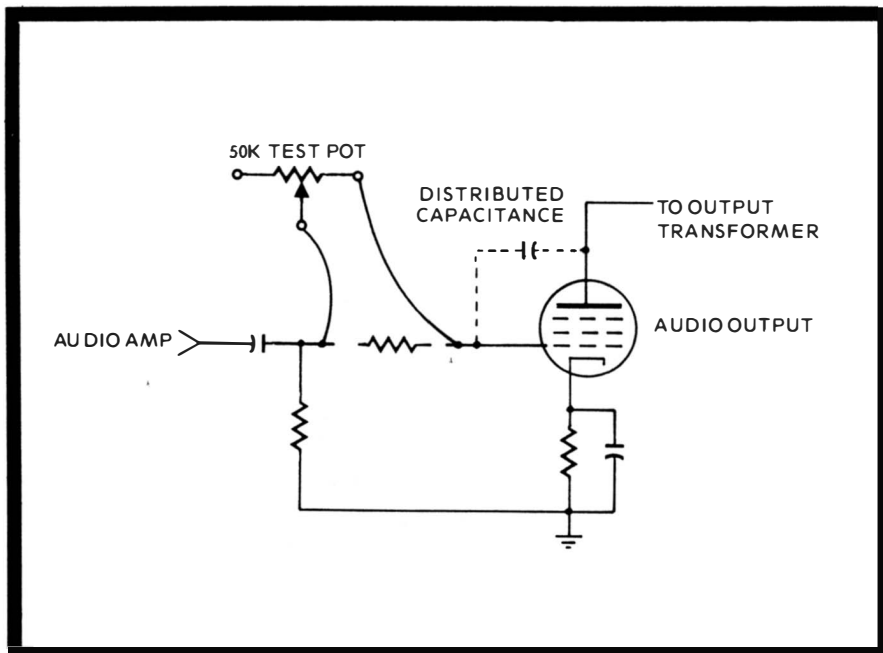

Fig. 105. A tube in an intercom can oscillate. A 50K test pot will dampen the oscillations.

4 ohms. In a radio the amount of wire between the output transformer and the speaker is less than an inch and is, therefore, never considered in design. In an intercom system the amount of wire between the transformer and speaker may be any length. A separation of one hundred feet means in effect that 200 feet of wire is strung between the transformer and speaker, since the wire has two conductors, one each way.

Number 22 wire, the typical type used, has a resistance of 16 ohms per thousand feet. Two hundred feet of wire would have over 3 ohms resistance. This amount of resistance in series with the 4-ohm transformer and the 4-ohm speaker (more accurately about 3.5 ohms) can cause between a 40 and 50 percent loss of the audio. This can be a serious loss in an intercom and has to be considered during the design.

On the other hand, a speaker that has an impedance of 32 ohms and an impedance transformer of 32 ohms will be affected much less. The 3-ohm resistance of the wire is a lesser percentage of the 32-ohm units and dissipates just under 10 percent of the audio.

When designing an intercom set up, consider the amount of resistance in the wire. Its percentage in comparison to the

total impedance of the speaker and transformer gives you the approximate loss. For instance:

$$\frac{4 \text{ ohms of wire}}{4 \text{ ohms, spkr} + 4 \text{ ohms, Xfmr}} = \frac{4}{8} = 50\%$$

or

$$\frac{4 \text{ ohms of wire}}{32 \text{ ohms, spkr} + 32 \text{ ohms, Xfmr}} = \frac{4}{64} = 5\%$$

### No. 172: CABLE POWER LOSS TEST

If you have a long run of wire between stations, before actually going through the labor of installing the wire, hook up the units temporarily, running the wire loose between the units. If the number 22 wire is too high in resistance, the volume will not be high enough to be heard satisfactorily. Install larger diameter wire. For instance, try number 18 gauge. Keep lowering the gauge until the audio is loud enough.

### No. 173: SPEAKER IMPEDANCE CONSIDERATIONS

In simple intercom systems that employ a master and one remote, common 4-ohm speakers are usually used. Quite often it becomes desirable to add more remotes. The amplifier can easily service the additional units, yet the installer encounters a drastic reduction in volume.

The first thought is that the amplifier can't handle the load. This is usually not true. What has probably happened is that the additional remotes also have 4-ohm speaker and all those 4-ohm units in parallel, plus the additional wiring, causes heavy volume losses.

When such a problem arises, the answer is simple. Remove the 4-ohm speakers and install 32-ohm or 45-ohm speakers. At least use 16-ohm or even 8-ohm types. The additional impedance improves the ratio of speaker impedance to the connection cable loss and also raises the combined parallel impedance of all the speakers to a more normal match with the output transformer.

It works out in actual practice that when the speaker impedances are more than the output transformer impedances, the transfer of energy is more efficient than if the speaker impedances are less than the output transformer. This is because, as the mismatch gets down below 4 ohms, the percentage of mismatch is much higher, than when the mismatch is about 4 ohms.

## Chapter 14

# Garage Door Openers

### No. 174: HOUSE CURRENT CHECKOUT

There are lots of garage door opener systems. The typical one, however, is broken down into five sections (Fig. 106). One is the power supply which is the house current, 117 volts AC. This rather obvious section of the system is mentioned first because it is the first source of trouble in a large percentage of cases. If a short circuit develops in the wiring of the motor, or the door should jam along the tracks, too much current can be drawn from the fuse or circuitbreaker and the system cuts off.

On a rare occasion the fuse, circuitbreaker or actual house current input circuit could be defective, but usually when the fuse goes, an overload is occurring in the door opener circuits. Test the door opener carefully; it is causing an overload.

The other four sections of the system are the receiver, the motor and machinery, the transmitter, and the pushbutton circuit mounted in the garage. The transmitter cannot possibly blow a house fuse since it is not connected by wire to the system.

The trouble is usually in the motor and mechanical section. After changing the fuse, try the motor with the manual pushbutton in the garage. If the motor starts jamming, shut off the fuse or circuitbreaker immediately. The trouble is in the motor and machinery.

### No. 175: MOTOR AND MECHANICAL CHECKOUT

A mechanical checkout is recommended first. However, it must be done to decide whether the trouble is mechanical or electric. Disconnect the mechanism from the door and work the door the old fashioned way—by hand! You'll feel if the door is running on its tracks smoothly or not. If it is, reconnect the mechanism. The trouble is not in the door.

Should the door run rough, stick or jam, find out why. Perhaps the runners need lubrication or some foreign object is jamming it. At any rate, figure out the mechanical difficulty. Watch any gears, pulleys and other parts.

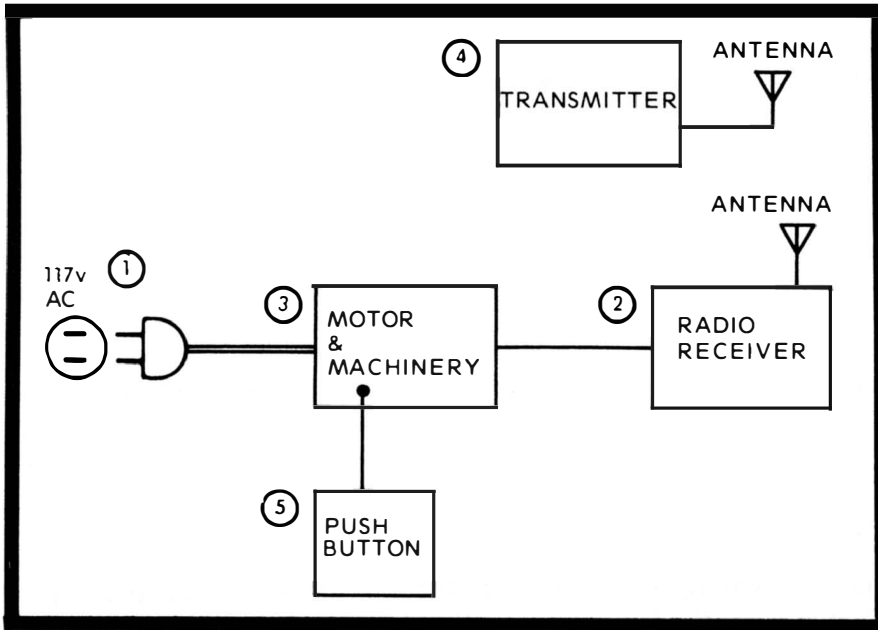

Fig. 106. The five sections of a garage door opener are the transmitter, receiver, motor, wall button and power supply.

### No. 176: MOTOR SHORT TEST

The main part of the opener is the motor. Its operation is the final result of all the electronic activity. The motor is quite tiny, rarely more than a quarter horsepower and usually less. The motor is activated by a capacitor. A capacitor-start motor comes up to full speed almost at once and can reverse itself easily upon electronic directions.

Capacitor-start motors have two windings. One is in the circuit all the time and is called the "running winding." The other, which is in series with the start capacitor and the switch, is called the "starting winding." As the double-pole double-throw switch is reversed, the starting winding is reversed. This DPDT reversing switch is mounted on the mechanism so that when the door reaches the end of the track, either open or shut, the switch is thrown and is ready for the next movement of the door in the opposite direction.

A centrifugal switch is also in series with the DPDT and capacitor. It closes the circuit each time to start a cycle, either open or shut. The DPDT simply stops the cycle and readies itself for the next cycle.



When the motor circuit is indicated as shorted because of fuse or circuitbreaker failure, the simple circuit can be tested for a short circuit with an ohmmeter (Fig. 107). The capacitor could short, the run winding could short and the start winding could short. A simple ohmmeter test will reveal it.

#### No. 177: MOTOR OPEN-CIRCUIT TEST

The motor circuit, due to the large current drawn through it during quick starts, could burn open. The starting capacitor could open up. The best test is to try a new one. The DPDT switch could open up, too. If that happened, the centrifugal switch would not be able to start the motor. The centrifugal switch could also open. The motor itself sometimes burns up and stops functioning. Here, again, the best test is a new motor.

#### No. 178: MOTOR RUNS IN ONE DIRECTION

If the door will open and not shut, or shut and not open, the prime suspect is the DPDT reversing switch. One side of it has probably opened.

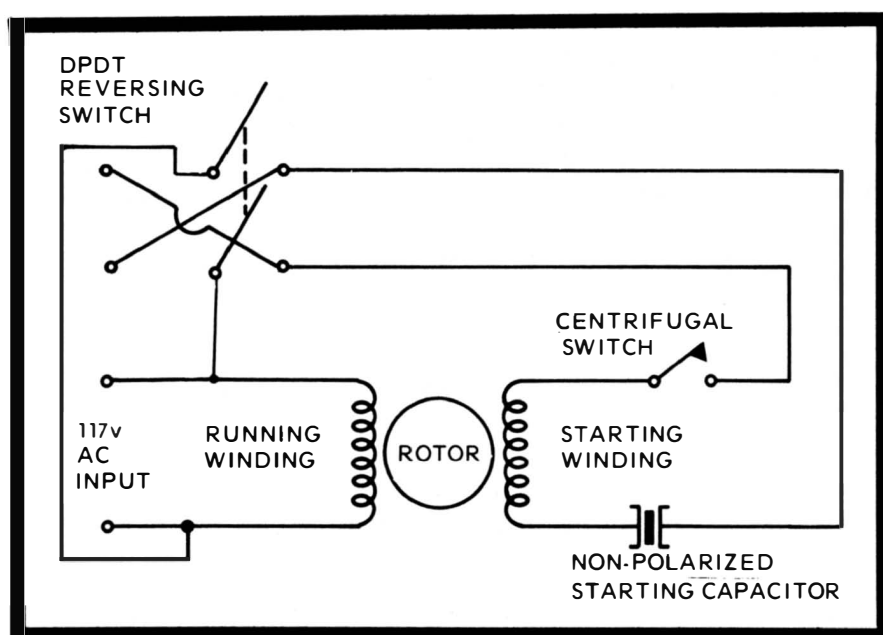

Fig. 107. A capacitor-start motor uses a nonpolarized filter and centrifugal switch in the start winding.

## **No. 179: ELIMINATION OF GOOD REMAINING UNITS**

Once it is decided that the trouble is not in the power supply or the motor-mechanism area, three sections are left: the push-button circuit on the garage wall, the receiver and the transmitter. Push the button on the wall. Does the door open and shut normally? If it does, the trouble is in the receiver or transmitter. Should the door not open or shut normally, then the pushbutton circuit is indicated. It is a simple wiring job that connects to the motor and gear box. Check it.

## **No. 180: RECEIVER OR TRANSMITTER?**

If you have a spare known good transmitter handy, this is the best test. Try to get the garage door to go up and down with the spare. If it will, the old transmitter is definitely defective. If it won't, the receiver needs further testing.

Unfortunately, a spare transmitter is not always available. Also, the amount of power that comes out of the transmitter is very tiny. You'll have to rig up a form of field strength meter. This is done with some wire and a tiny neon bulb. Wind a coil on a pencil that will respond to the approximate frequency of the transmitter. Attach the neon tester to the coil.

Then, place the little field strength indicator against the transmitter antenna. Try the transmitter (Fig. 108). If the neon lights up, RF is coming out of the transmitter and it is probably good; the receiver must have problems. I say, probably, because some door openers have a modulated RF transmission. The RF could be good and the modulation missing or incorrect. This would be a rare occurrence, however.

## **No. 181: TRANSMITTER TEST**

For the particular transmitter you are testing, you'll need the schematic and service notes from the manufacturer. These transmitters are quite similar to a remote control model radio transmitter, except for one thing. The FCC has a garage door opener regulation which states that these transmitters can send out only a short timed burst of RF energy and then must shut off, even if the transmitter button is held down. This is to prevent any of these transmitters from sending out RF that could possibly interfere with aircraft radio communications. Door opener transmitters cannot be left on. The pulse can last

for only one second out of every 30-second period. When the transmitter button is pushed, there is a one-second RF modulated pulse that quickly shuts itself off, even if the button is held down. If you want to try another pulse, you must wait 30 seconds. The unit won't operate for that length of time.

The receivers are designed to receive the one-second pulse. It's actually, from an electronic point of view, a large segment of time, one million microseconds. The pulse goes through the receiver, the modulation is detected and the audio modulation is fed to a small relay instead of a speaker, like a radio. When the small relay closes it causes the larger relay to close and the motor starts. The motor pulls the door up or down and the reversing switch opens the circuit at the end of the track. The door is then ready for a run in the other direction.

The transmitter, usually transistorized, has an oscillator circuit, quite often crystal controlled if the frequency transmitted is in the high range, for instance 465 MHz. On the other hand, the frequency could be down in a low range; for instance, 41 kHz. In the high range, the code signal to trigger the relay modulates the RF. In the low range, the code signal turns the RF off and on by switching in the transmitter. Whatever the procedure, the receiver is constructed to respond to its own transmitter and none other. Otherwise, a

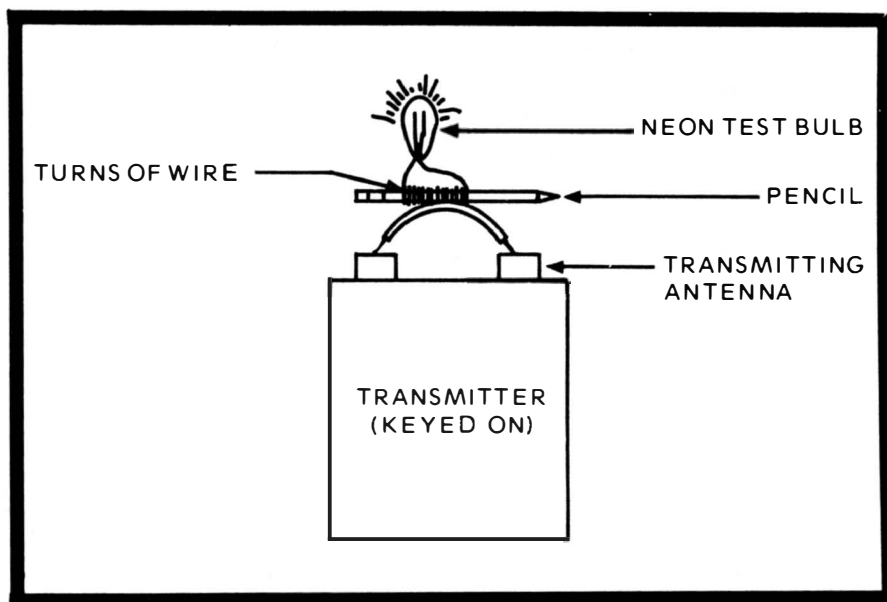

Fig. 108. A transmitter output test can be conducted with a tuned winding attached to a neon.

next door neighbor could get your garage door open with his transmitter.

An unlimited number of transmission systems can be designed by selective coding. A selective filter picks out a code even if it is a signal such as 250 Hz and other transmitters are sending out 260 and 240 Hz. Another consideration during design is freedom from noise. Noise could possibly open or shut the garage door unless it is carefully designed out. At the high frequencies, ordinary electrical static and lightning flashes have no effect. In the 41-kHz range, noise is a problem, so they use what is called a double coding system. The door won't open unless both codes from a transmission are received. The chances of an accidental noise burst generating both codes at the same time is almost nonexistent.

Another type of transmission can be right down in the audio range between 2000 and 10,000 Hz. This is a transmitted RF signal and is completely free of noise or other transmissions. The FCC has no restrictions at this low range. The main limitation is the size of antennas; they have to be large. You can work on any of the transmitters legally, since the higher frequency ones have a low enough power to be under the legal restrictions and the low-frequency ones are so low there are no restrictions.

A typical low-powered transmitter has one transistor in an oscillator configuration, with the frequency controlled by a crystal. Or it could be two transistors in a multivibrator arrangement. The factory service notes will tell you which one it is and what voltages should be where. You can't isolate the trouble any further than this. Once it is decided that the transmitter is defective, routine DC voltage and resistance tests are next. Some transmitters have a plug-in decoding device so the same transmitter can send out different modulations. The only practical test is to try a new plug-in unit.

## **No. 182: RECEIVER TEST**

The receiver is quite like an ordinary radio, except that it is fixed tuned and variably tuned. Also, its output goes to the relays and not to a speaker. Old-time garage door openers used one tube in a super-regenerative circuit. Then, 3- and 4-tube receivers appeared. Finally, the transistorized receiver was made.

The receivers are designed to be on continually. The tube circuits cost a few pennies a month to operate, but the tran-

sistor circuits cost practically nothing. Both tube and transistor circuits are designed with cutoff bias applied. Therefore, no current, or very little, passes through the tube or transistor during the standby operation. When a pulse arrives, it overcomes the bias and some current is drawn for an instant. Since this occurs just a very few times a day, it is not even measurable in pennies.

The signal is picked up by the antenna, passed through an RF amplifier and then injected into a detector. The detector output is the modulation or code, which is converted into a DC signal that fires the relay transistor. The motor opens or shuts the door. When the transmitter is deemed good, and the push-button on the garage wall makes the door open and shut normally, the receiver is, by elimination, considered defective.

#### **No. 183: SHORTENED RANGE TEST**

Should the garage door opener work, but not at a distance, the receiver has weakened. The door may open when you pull up next to it, but not when you transmit a pulse as you round the end of the driveway. If it is a tube receiver, test the tubes. A weak tube could be the trouble. In a transistorized receiver, the transistors also could be weak.

What's happening is that the transmission is not overcoming the bias on the amplifiers from any distance. This could be due to lowered plate or collector voltages or raised cathode-control grid or emitter-base bias. Approach the testing as if you had weak audio in a radio. According to the service notes, test the DC resistances and voltages as well as the tuning of the RF transformers.

#### **No. 184: RELAY NOT CONTACTING TEST**

The relay has the job of opening and closing, period. If you transmit a pulse and the relay is activated, that is, there is a click, then the receiver is working. Should the motor still not start after the click, the trouble could be in the relay contacts. Either they are not touching, or are so pitted or corroded they pass no current even when they do make contact.

There are the two relays (Fig. 109). One is the receiver relay and the other is the heavy-duty motor relay. The receiver relay triggers the motor relay.

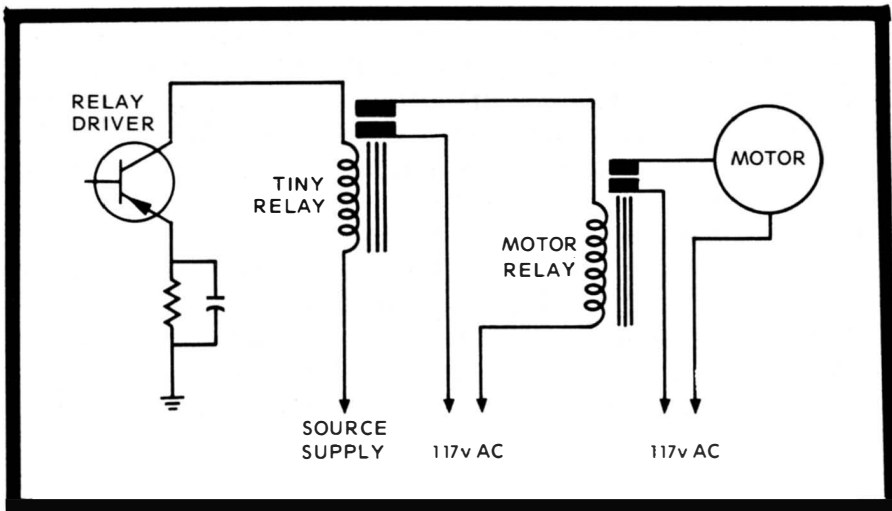

Fig. 109. Typically, a motor relay in a garage door opener is a heavy duty type. It's operated by a tiny circuit relay.

The test is easy. Take a small piece of wood or a pencil and press the relay shut. Even though the contacts are corroded the motor will start if the relay is the trouble. Cleaning or replacement will fix it. Test both relays this way.

#### No. 185: RELAY CHATTER TEST

The relay has spring tension applied to the armature. The amount of tension is carefully designed. The strength of the magnetic field, under normal operating conditions, is enough to overcome the tension and cause the relay to close.

When the magnetic field gets weak, it will still attract the relay armature, but as the spring bends and builds up tension, the amount of magnetic flux is not enough to pull it all the way. The spring, as a result, pulls back the armature quickly. The net result is a chattering relay. Usually, a weak output signal from the receiver is the reason for the chattering relay. Go back to the receiver and test it for weak amplification.

#### No. 186: UNWANTED OPERATION ADJUSTMENT

A major problem that occurs with garage door openers is unwanted operation. The door goes up and down by itself. This can be quite annoying and under some circumstances hazardous. Some kind of signal is triggering the receiver and

it is not coming from the transmitter. If there is a gain control on the receiver, try resetting it at a lower threshold. If the gain control is cranked all the way up, the receiver gets overly sensitive in the same way a radio speaker blasts too loud when the volume control is turned all the way up. The more stages of amplification in the receiver, the more sensitive the receiver. Try different settings of the gain control, keeping it set as low as possible, of course.

If necessary, adjust the gain until it is almost off. You might even have to pull your car right up to the door in order to trigger the relay; however, that is preferable to the door going up and down out of control.

#### **No. 187: UNWANTED OPERATION DUE TO NOISE**

If you can pinpoint the cause of the unwanted operation as being due to noise, in addition to desensitizing the receiver as above, it may be necessary to make the receiver more frequency sensitive. Perhaps you'll find the garage is near a high-voltage line or the receiver antenna is close to some other AC line. If so, you'll have to improve the signal-to-noise ratio at the receiver input or improve the peak alignment inside the receiver so it responds to a more narrow band of frequencies.

Make sure that the transmitting antenna is not enclosed under the metal hood of the car. If it can be attached to the car radio antenna, all well and good. If there is a tuning capacitor in the antenna circuit, try different settings until you get one that is the most sensitive. Park the car at the bottom of the drive and start triggering the door. If your distance is about 100 to 200 feet, you'll find that at extreme settings of the capacitor, the door won't open. At the correctly tuned setting, the door opens and closes beautifully. When you have the gain as low as possible and the antenna transmission as strong as possible, the improved signal-to-noise ratio will enable the receiver to respond correctly.

#### **No. 188: UNWANTED OPERATION, ALIGNMENT**

If your garage door is going up and down and you can pin the reason for the unwanted operation on a nearby transmitter, there is probably something wrong with your receiver and not the transmitter, especially if you need the gain control turned

all the way up in order for your car transmitter to activate the garage door.

After testing all the tubes, transistors, DC voltages and resistances, if it's still happening, the receiver probably needs alignment. The receiver is a small radio type circuit with TRF type coupling between stages. With the manufacturer's service notes and your radio alignment equipment, align the RF transformers between the stages. At the correct peak alignment the unwanted operation should cease.



## Chapter 15

# Auto Ignition Systems

When the car cranks but won't start, idles rough, stalls and misses, the ignition system probably is the troublemaker. Ignition systems, both conventional and transistorized, are quite simple in comparison to most electronic circuits and comprise little more than a special type of power supply. However, the electronic technician, unless he has had experience with ignition systems, has no idea of what's happening inside. It would be useful to go through the action of an ignition circuit before discussing ten of the typical tests.

The system is centered about the ignition coil which is something like a "flyback" transformer in a TV high-voltage system (Fig. 110). The primary of the ignition coil has in its circuit the ignition switch replete with the car key switch, a ballast resistor the primary coil winding, breaker points, the battery connecting cables from the hot side of battery to the distributor and the grounding strap from the battery to the auto chassis. The secondary circuit of the ignition coil contains the step-up winding, the distributor cap and the rotors under the cap, the connecting cables from the distributor cap to the secondary coil and to the spark plugs, and the ground strap from the last spark plug to the auto chassis.

The electrical cycle is entirely dependent on the flyback like action from the ignition coil. The key is turned in the ignition switch, completing the circuit from ground on the battery through the ignition switch through the ballast resistor, the ignition coil primary, the breaker points back to ground. The condenser charges. The surge of electrons from minus of the battery to the breaker ground produces a large electromagnetic field around the primary. Then the breaker points open and the current ceases instantaneously. The magnetic field collapses. Its violent collapse induces current flow in the secondary of the coil. The condenser discharges, further quickening the collapse.

The current flow is so swift that a large voltage potential is produced. The size of the voltage is directly proportioned to the turns ratio between the two sections of the coil, which is

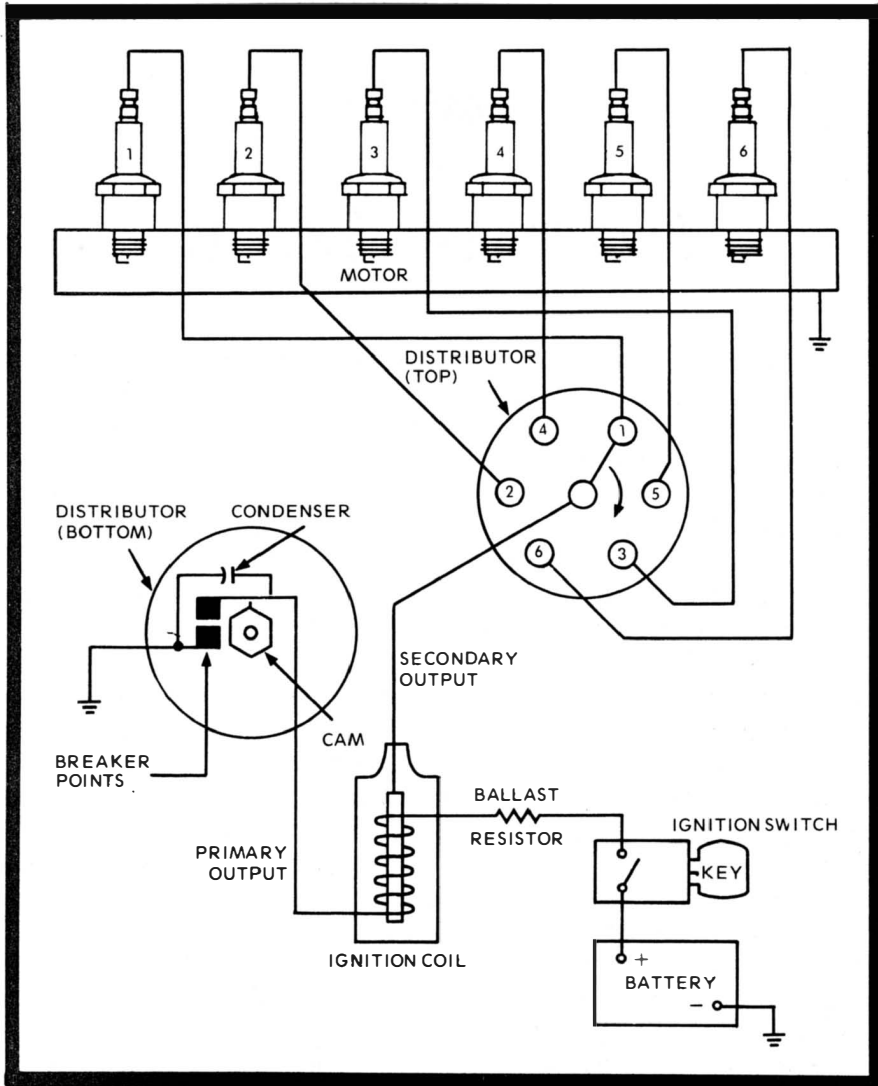

Fig. 110. The typical auto ignition system is nothing more than a specialized type of battery power supply.

very high. A heavy charge of high voltage, which is in the vicinity of 10,000 volts, flows to the distributor cap, through the rotor, to the spark plugs and back to ground.

The rotor transfers the charge to each spark plug in turn. Typically, there are cars with four, six and eight cylinders, with the same number of spark plugs. The distributor rotor turns 360 degrees in one revolution as it gives each plug a shot of electricity. The rotation covers a certain number of degrees between plugs. In a 4-plug engine there is 90-degree space

between the plug wire connections. In a six cylinder there is 60-degree space and in an eight there is 45 degrees rotation between plug connections.

If you attach an ignition analyzer oscilloscope strategically in the primary and secondary, you can observe the complete operation of the ignition system. You can see the primary waveform, the secondary waveform and all the cylinders at once, called the paraded waveform.

#### **No. 189: IGNITION SYSTEM PRIMARY WAVEFORM**

Set the analyzer on triggered sweep and attach two direct probes, one to the vertical input and the other to the horizontal input. You are now ready for the next three tests. For the primary waveform (Fig. 111), attach the vertical probe across the primary circuit. Attach the horizontal probe across the secondary circuit. As each plug fires, the horizontal will sweep with the secondary waveform and the vertical will sweep with the desired primary waveform. As each spark plug fires, the waveform will appear on the scope face, but faster than your eye can follow, so they are super-imposed on one another. If a stable pattern is displayed, then the ignition system is functioning well. If the patterns appear to blur, there is trouble.

The actual waveform that you see is the result of the following events:

1. The points open, the magnetic field collapses and produces a flyback secondary voltage around 10KV.
2. The high voltage jumps across the spark gap and produces a damped oscillation.
3. The condenser charges and then begins to discharge.
4. The points close and dwell time occurs.
5. The points open again and the next cycle begins.

#### **No. 190: IGNITION SYSTEM SECONDARY WAVEFORM**

With the scope set in exactly the same way, the probes are reversed. The vertical probe is attached across the secondary circuit and the horizontal probe is across the primary circuit. The horizontal sweep is supplied by the primary and the vertical amplitude is a result of the secondary voltage. The vertical amplitude is observed.

The waveform on the scope screen is the result of the following events:

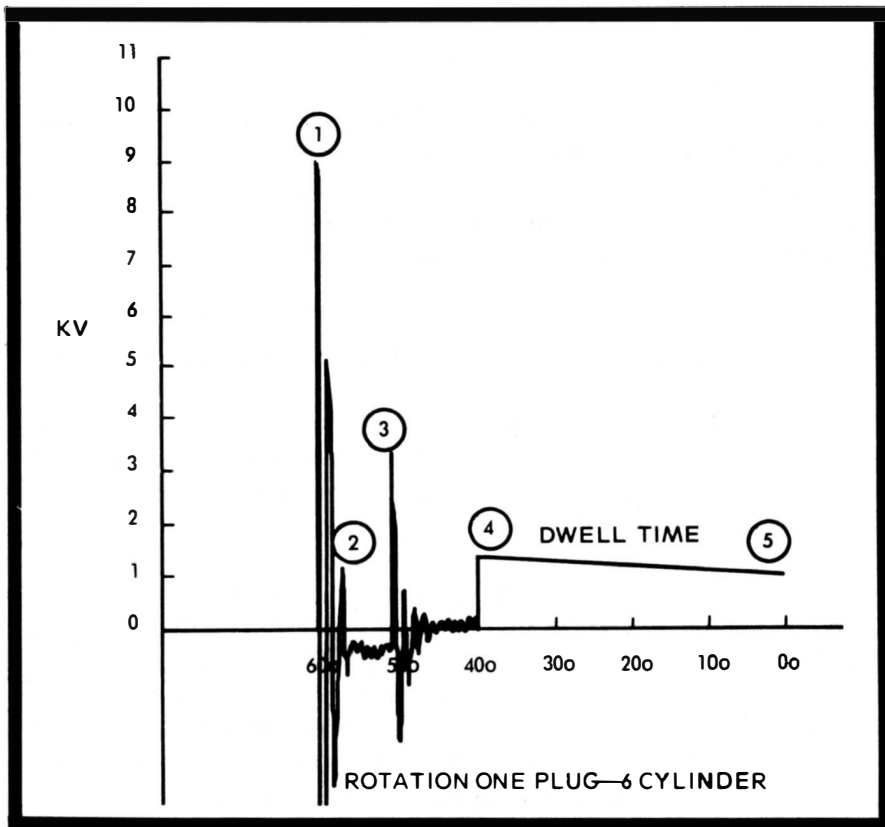

Fig. 111. Typical waveform across the ignition coil primary.

1. The points open and the secondary hasn't been affected by the flyback action as yet. The plug fires and the magnetic field collapses.

2. The coil and the capacitor begin oscillating after the plug fires. The oscillations are dampened.

3. The points close and dwell time begins.

4. The points re-open and the next cycle begins.

Notice that there is only one oscillation in the secondary waveform and it doesn't start until the spark plug fires. Also notice that when the points close, the polarity is opposite to the primary pattern. This is due to the 180-degree phase reversal in a transformer.

Like the primary pattern, a stable display means that all is well, but a badly fluctuating display indicates something is wrong in one or more of the plug firing cycles. The paraded view is useful to view all the plug firings at once.

## No. 191 : PARADED WAVEFORM

To get a paraded display, you must divide the horizontal sweep input into a fraction equalling the number of plugs used. For instance, if there are four cylinders the horizontal frequency must be  $\frac{1}{4}$  of the vertical frequency. For six plugs,  $\frac{1}{6}$ , and in an 8 cylinder,  $\frac{1}{8}$ . This is easily obtained by attaching the horizontal probe across the first plug and the vertical probe across the ignition secondary circuit. That way, the horizontal is swept only once for each rotation of the distributor cam while the vertical is swept each time the rotor hits a plug connection.

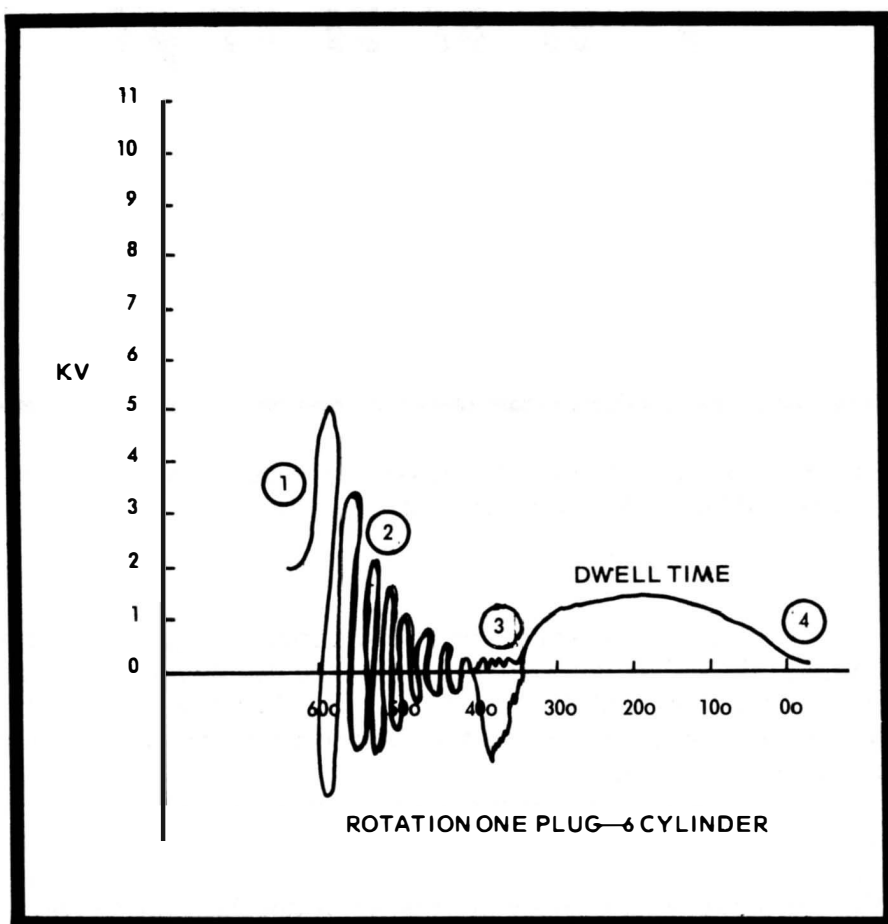

Fig. 112. The waveform across the secondary of the ignition coil has a similar appearance but subtle differences.

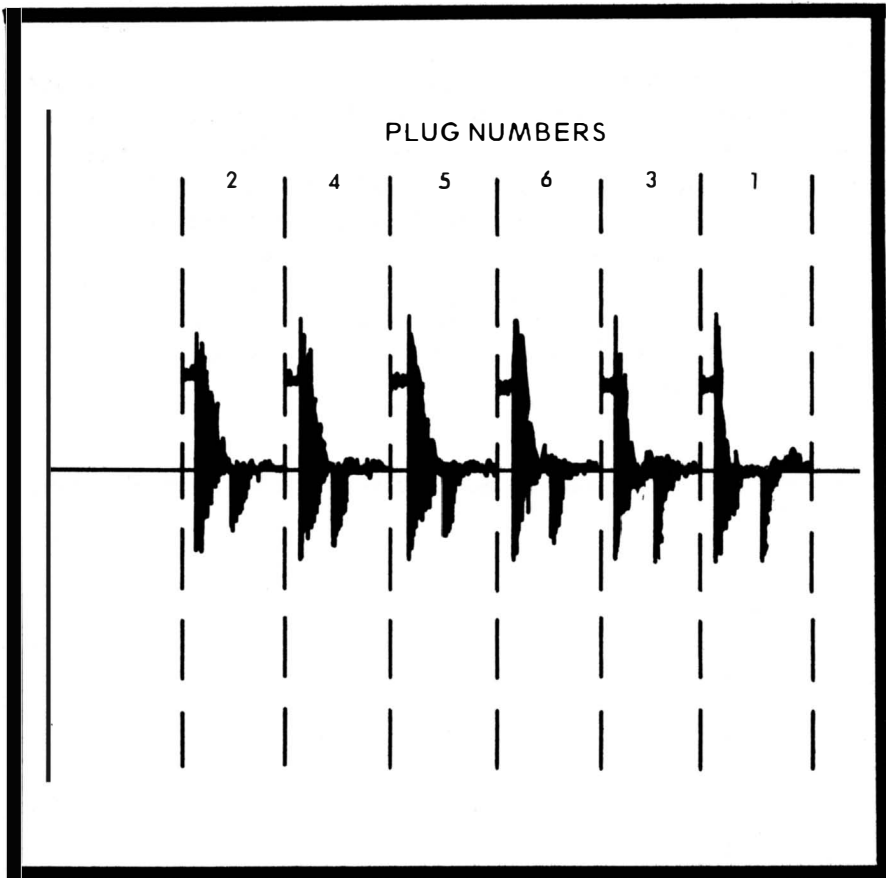

Fig. 113. The waveforms across all cylinders are arranged in a parade of look alikes when all is well.

Typically, the display for the number one plug will be found at the extreme right (Fig. 113), the number two plug at the extreme left and the rest of the plugs in between. For the actual display order, see the manufacturer's service notes for the plug firing order.

The paraded waveforms show each cylinder pattern in order of the way the plugs are fired. Each waveform can be analyzed on its own. You can see the size and shape of the flyback spike, which tells you whether or not the ignition coil is always producing a high enough voltage and if the shape of the spike is correct. The parade displays all of the coil-capacitor oscillations and dampings. A defect is easily seen. Point closing is accurately displayed and the actual dwell time can be noted for correctness.

## **No. 192: PARADED COMPRESSION CHECK**

An important test that can be made electronically is the amount of compression that exists in each cylinder of the motor. The measurement is a rough percentage of contribution. Or in other words, how much power is each cylinder contributing to the total power?

A tachometer is needed that shows engine speed in RPM, as well as an ignition analyzer with a shorting tube. The cylinder selector control is adjusted to select a specific cylinder, except the number one cylinder. With all equipment running, the shorting tube effectively creates a short across the selected cylinder. The motor miss fires when that cylinder is supposed to fire, of course. The RPM drops, and the drop is measured and compared to the total RPM when all cylinders are firing. The percentage of the RPM drop tells you the contribution that cylinder is making to the total power of the engine. You can see which cylinder is not firing on the paraded display (Fig. 114).

## **No. 193: NUMBER ONE CYLINDER COMPRESSION CHECK**

While all the other cylinders are checked easily, the number one cylinder cannot be shorted out during the routine test, since it supplies the initial pulse to trigger the horizontal sweep of the scope. Therefore, a special test for number one must be made. This is accomplished by using an additional pulse generator to substitute for the pulse that will be lost when number one is shorted. The special pulse must be injected into the horizontal input circuit when cylinder number one is shorted out (see below). Then, the horizontal sweep is maintained and the paraded waveform is still observed.

## **No. 194: MARKING THE PARADED WAVEFORM**

The typical ignition analyzer has a marker generator circuit. The marker generator is pulsed into conduction each time cylinder number one is fired. The marker gets a portion of the same pulse that is applied to the horizontal trigger amplifier.

A variable resistor is usually placed in the control grid circuit of the marker amplifier. Adjusting the potentiometer varies the RC time constant of the grid circuit. The pot can be

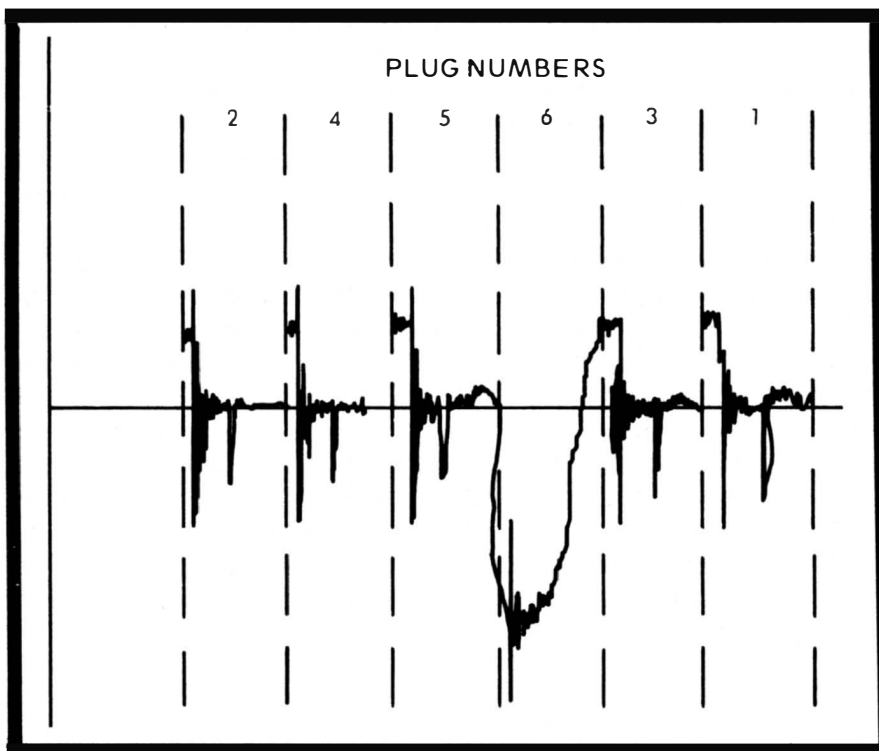

Fig. 114. With the number six plug shorted purposely for a test, the paraded waveform takes on this appearance.

adjusted to delay the conduction long enough so that the pulse can be made to occur at any time during the horizontal sweep. Since all the cylinders are fired once during one horizontal swing, producing the paraded waveform, the marker can be displayed over any one of the elements of the parade. Any specific cylinder can be marked.

#### No. 195: TIMING LIGHT CHECKS

An ignition analyzer's timing light is set to flash each time plug number one fires. The pulse from plug number one is applied to the input amplifier of the timing control circuit. The pulse causes the amplifier to conduct.

The first amplifier feeds into the second amplifier by way of the connection between the two cathodes. As the first amplifier conducts, the second, with a corresponding cathode bias, also tends to conduct. The timing light flashes are a result of the conduction of the second amplifier. Therefore,



under normal conditions, the two tubes conduct simultaneously as the number one plug produces a pulse (Fig. 115).

In the control grid circuit of an ignition analyzer there is a potentiometer. With the pot in the off position, both tubes conduct at the same time. However, as you add resistance by advancing the control, a time delay occurs in the grid circuit, which causes the second amplifier to conduct after the first. The length of the time delay in is measured in the plate circuit of the first amplifier by means of a meter. The timing light fires only during the conduction time of the second amplifier.

### No. 196: RPM MEASUREMENTS

The familiar tachometer (TACH) on the engine analyzer is calibrated in revolutions per minute. The electronic tachometer typically gets a pulse also from plug number one every time it fires. The pulse is fed to an RPM trigger circuit (Fig. 116). In the trigger circuit there is a tube or transistor that is biased to cutoff but which conducts every time a pulse is received from plug number one. The pulse either causes the

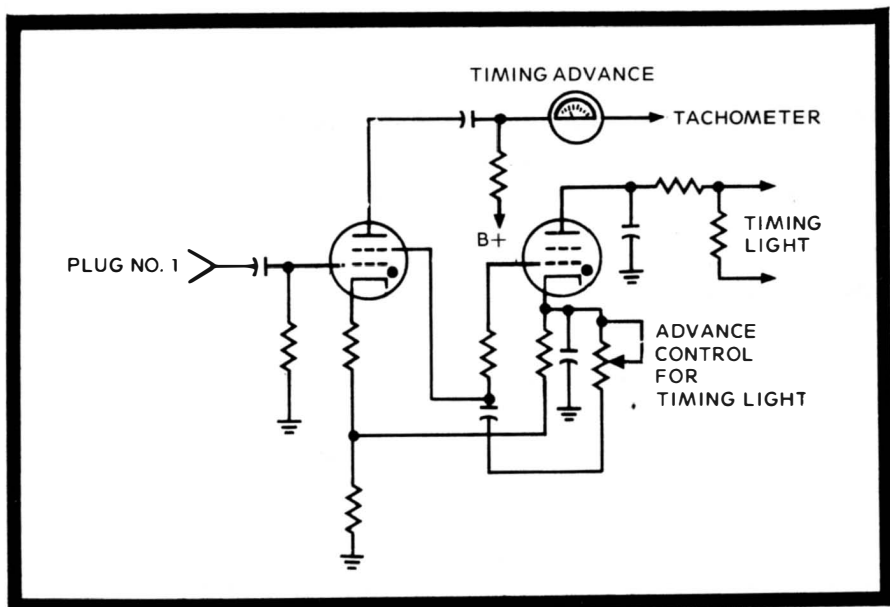

Fig. 115. A typical timing light circuit receives an input pulse every time the rotor fires the number one spark plug.

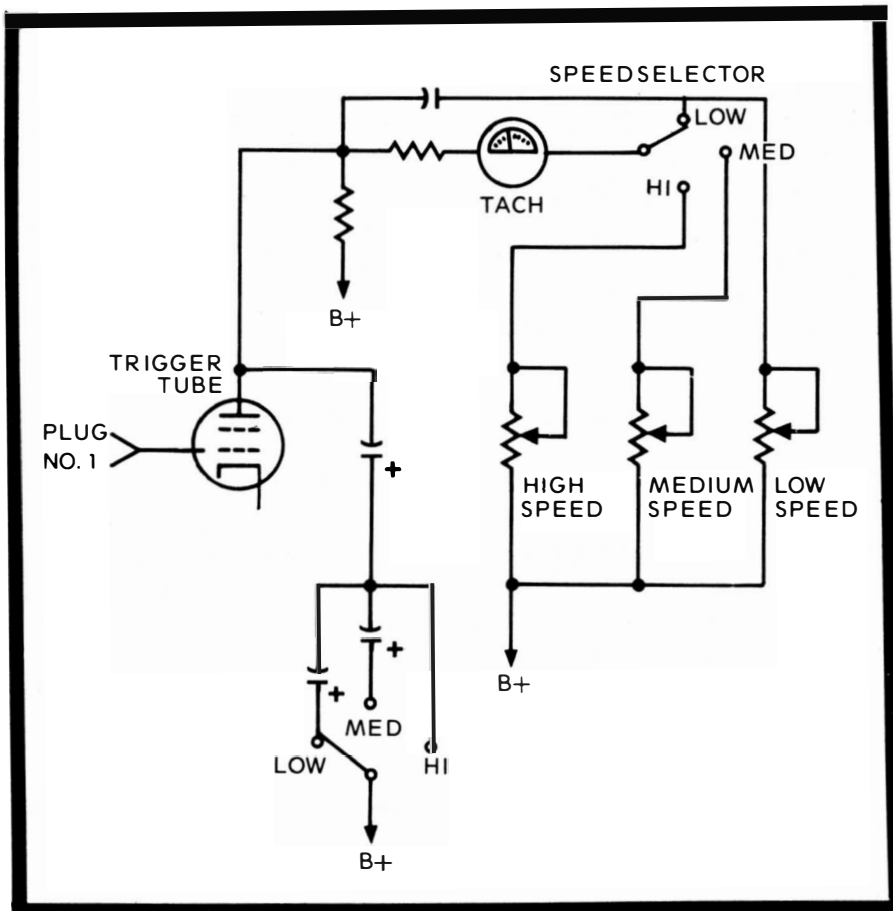

Fig. 116. In a typical tachometer circuit, a trigger tube receives a pulse every time plug number one fires. Different filters and potentiometers are used for different speed ranges.

control grid to go positive from a negative cutoff or forward biases a transistor, changing its reverse bias. The plate or collector current flow is applied to a filter network. The network has a 3-position switch that selects the speed range.

The switch puts either one filter or two filters into a desired configuration. The capacitor, or selected pair of capacitors, charge every time the number one plug fires. The charging thus takes place once during every plug firing sequence. Then, between charges, or during the time the other plugs are firing, the capacitor tends to discharge. The discharge takes place through an RC network composed of a

large filter and a resistor connected to the regulated power supply. The large RC time constant smooths out the charge to an average DC level.

As the motor slows down and the triggering rate slows down, the average DC level is lowered. As the motor speeds up and the triggering rate increases, the average DC level rises because the higher number of triggering pulses does not let the capacitor lose as much of its charge as it tends to discharge. The meter in series with the DC level reads higher and lower according to the speed of the motor and the resultant triggering charges from plug number one. It reads directly in RPM.

The only problem arises when the motor is running at very low speeds. The capacitor charges so slowly that it can actually lose its charge. The meter needle will bounce back and forth and be impossible to read. Another filter is placed in parallel across the meter to average out these slow readings. As a result, these readings are not too accurate. The parallel filter is effectively out of the circuit during higher motor speeds.

#### **No. 197: VOLTAGE READINGS FOR OPEN CIRCUIT**

The voltmeter provides important tests in an ignition system. The ignition voltmeter is not as exact as the electronic bench voltmeter. A typical test is a check of the voltage between the plus end of the battery and the input of a transistorized ignition system. The input could be the emitter of a transistor.

The engine is turned over and the voltage measured. The total voltage when the current drain is high during initial ignition should be one volt or less. Should the voltage be much higher, approaching the 12-volt battery output, the lack of current drain indicates an open circuit in the ignition system.

#### **No. 198: VOLTAGE READINGS FOR SHORT CIRCUIT—POINTS OPEN**

Another typical test in a transistorized ignition system is a voltage check from the emitter of the input transistor to the chassis ground. This voltage should read the full battery voltage. The test is conducted with the ignition on but no cranking. If the battery voltage is low or missing, either the battery is weak or a short circuit exists in the circuit between the probes.

**No. 199: VOLTAGE READING  
HIGH—POINTS CLOSED**

Another typical voltage test in a transistorized ignition system is to run the same test as No. 198 with the points closed. This time, current should be drawn and the voltage should drop to about 6 or 7 volts. If it doesn't, some type of open circuit is present and needs further investigation.

The voltmeter is needed badly in testing ignition systems. Between it and the scope displays, the entire ignition system can be analyzed quickly and the defects pinpointed. There are many different types of ignition analyzers, but the tests covered are typical.

# Index

## A

AC beta, transistor, 120  
AC line voltage monitor, 66  
Acoustic feedback, 194  
Adjacent-channel sound, 87  
Adjacent-channel video, 87  
Adjustment, garage door opener, 208  
AFPC alignment, 79  
AGC, AM, 45  
AGC, TV IF, 69  
Alignment, AFPC, 84  
Alignment, FM, 61  
Alignment, FM converter, 57  
Alignment, garage door opener, 209  
AM AGC, 45  
AM antenna alignment, 38  
AM antenna test, 40, 41  
AM front-end alignment, 35, 36  
AM IF alignment, 26  
AM IF oscillation, 43  
AM local oscillator test, 41  
Amplifier, organ, 179, 180  
Antenna line loss, 101  
Antenna mounting, multiple, 110  
Antenna test, AM, 40, 41  
"Attack" amplifier, 180  
Audio generators, 18  
Audio remote control, 162  
Audio transistor test, 156  
Auto ignition system, 211

## B

Bias, diode, 117  
Bleeding, color picture, 74  
Bridge test, 154  
Broadband alignment, AM, 31  
Burst, color sync, 80

## C

Cable power loss, intercom, 197  
Calibration, scope, 13  
Capacitance decade box, 25  
Capacitor test, 155  
Center convergence, 75  
Circuitbreaker failure, 67  
Color burst, 80  
Color circuits, 98  
Color purity, 72, 73  
Color spots, black-and-white picture, 73  
Color sync, 79  
Color TV convergence, 74  
Component bridge tests, 154  
Component substitution test, 153  
Compression check, 217  
Convergence, color TV, 74  
Crosshatch convergence, 76  
Cross modulation, TV, 110  
Current amplification, transistor, 120  
Current drain, EVC, 190  
Current measurement, 65

## D

DC beta, 23  
DC beta, transistor, 120  
DC high voltage, 91  
Dead EVC, 189  
Dead remote receiver, 177  
Decade box, 25  
Decibel, 100  
Demodulator probe, 92  
Demodulators, color, 98  
Depletion mode bias test, 133  
Depletion mode, FET, 129  
Diode bias, 117  
Diode polarity determination, 147  
Diode tests, 148, 149  
Discriminator alignment, FM, 46  
Dissipation, FET, 141  
Divider circuits, organ, 186  
Divider, organ oscillator, 183  
Dot convergence, 74  
Dual FET tests, 139  
Dynamic convergence, 77

## E

Electronic organ, 178  
Electronic vocal chords, 187  
Emission test, tubes, 19, 20  
Enhancement mode, 129  
Enhancement mode bias test, 134

## F

Ferrite core antenna alignment, 37  
FET, 24  
FET dissipation, 141  
FET Gm, 131  
FET leakage, 138  
FET matching, 140  
FET multimeter, 11  
FET open test, 135  
FETs, 127  
FET short test, 135  
Field-effect transistor, 24  
Field intensity, 105  
Field strength meters, 16  
17, 18  
Field strength test, TV, 103  
FM converter, 57  
FM discriminator alignment, 46  
FM IF-limiter alignment, 49  
FM multiplex, 59  
FM ratio detector, 49  
FM RF alignment, 57  
Forward bias, diode, 117, 118  
Freeze test, 144  
Frequency measurement, 15  
Front-end alignment, AM, 35  
Fusible resistor failure, 68  
Fuse failure, 67

## G

Gain, db, 100, 101  
Garage door opener, 201

Garage door opener, receiver, 206  
Garage door opener, transmitter, 204  
Gas test, tube, 21  
Gm, FET, 131  
Gm, field-effect transistor, 24  
Gm test, tube, 21  
Grading diodes, 150  
Gray-scale, 72  
Grid-dip meter, 40

## H

High-impedance probe, 94  
High voltage, TV, 90  
Horizontal output current, 71

## I

IF alignment, AM, 26  
IF-limiter alignment, FM, 49  
IF oscillation, AM, 41  
IF signal tracing, TV, 92  
IF, TV, 86  
IGFET, 131  
Ignition system, auto, 211  
Impedance matching, 112  
Intercom systems, 192  
Interference location, TV, 114

## J

JFET, 131, 138  
Junction FET, 131

## L

Leakage current, transistor, 23  
Leakage, FET, 138  
Leaky transistor, 124  
Line voltage monitor, 66  
Lissajous figures, 15  
Local oscillator test, AM, 41  
Lo-power ohmmeter, 145, 146  
Loss, db, 100, 101  
Loudness, 100  
Low-capacitance probe, 95  
Luminance amplifier, 96

## M

Make-sure transistor test, 123  
Master amplifier, 110  
Matching FETs, 140  
Matching, impedance, 112  
Matching, transistors, 140  
Microwatts, 103  
MOSFET, 116, 131  
Motor, remote receiver, 173  
Motors, remote control, 169, 170  
Motor trouble, garage door opener, 201  
Multiple antenna mounting, 110  
Multiplex failure, 63  
Multiplex, FM, 59  
Multimeters, 9  
Mutual transconductance, 21

## N

N-channel, FET, 127, 129  
Noise, garage door opener, 209

## O

Open test, FET, 135  
Open transistor, 121  
Organ electronic, 178  
Oscillation, intercom, 197  
Oscillator, electronic organ,  
178, 179  
Oscillator frequency,  
organ, 183  
Oscillator trouble, organ, 181  
Oscilloscope, 12

## P

Paraded waveform, ignition  
system, 215  
P-channel, FET, 127, 129  
Peak IF alignment, AM, 28, 29  
Peak-to-peak voltage, 14  
Picture sync, 97, 98  
Pitch, EVC, 190  
Power meters, 16  
Power monitor, 65  
Power supply ripple, 158  
Power transformer check, 157  
Primary waveform, ignition  
system, 213  
Probes, scope, 92, 93  
Pulse width test, EVC, 190  
Purity, color TV, 72

## R

Range, garage door  
opener, 207  
Ratio detector, 49  
Receiver alignment, remote  
control, 169, 170  
Receiver, garage door  
opener, 206  
Relay trouble, garage door  
opener, 207  
Remote control, 162  
Remote control receiver, 169  
Remote control receiver  
alignment, 169, 170  
Remote control transmitter  
alignment, 168, 169

Resistance decade box, 25  
Resistor test, 155  
Reverse bias, diode, 117, 118  
119  
RF AGC, TV, 69  
RF alignment, FM, 57  
RF generators, 15  
RF remote control, 162  
RF signal tracing, TV, 92  
Ripple, power supply, 158  
RPM measurements, 219

## S

Scope, 12  
Scope calibration, 13  
Secondary waveform, ignition  
system, 213  
Separation, stereo, 62  
Shorted transistor, 122  
Short test, FET, 134, 135  
Short test, tube, 21  
Signal generator output  
calibration, 107  
Signal generators, 15  
Signal injection, organ, 184  
Signal injection tests,  
intercom, 194  
Signal tracing, EVC, 189  
Signal tracing, organ, 182  
Signal tracing tests, 195  
Signal tracing, TV, 92  
Sound carrier, 86, 87  
Speaker phase, stereo, 59, 60  
Speaker system, organ, 181  
Standing wave ratio, 109  
Stepper relay, remote  
receiver, 177  
Stereo separation, 59, 62  
Stereo speaker phase, 59  
Stubs, UHF, 113  
SWR, 109  
Sync, color, 79  
Sync, picture, 97

## T

Tachometer, 220  
Thermistor test, 147  
Timing light check, 218  
Tracking, AM, 39  
Tracking, FM, 55  
Transducer, transmitter, 167  
Transistor matching, 140

Transistor substitution, 117  
Transistor test, audio, 156  
Transistor testers, 22  
Transistor tests, 116  
Transmitter alignment, remote  
control, 168, 169  
Transmitter, garage door  
opener, 204  
Transmitter output test, 167  
Transmitter, remote control,  
165  
Tube testers, 18  
Tint, black-and-white  
picture, 72  
Tuning, organ, 181  
TV cross modulation, 110  
TV field strength test, 103  
TV high voltage, 90  
TV IF, 86  
TVI location, 114  
TV master amplifiers, 110  
TV remote control, 165  
TV RF-IF signal tracing, 92

## U

UHF line losses, 113

## V

Varicap tests, 150  
Vectorscope, 84  
Video amplifier, 96  
Video carrier, 86, 87  
Video sweep modulation, 93  
Voltage amplifier, FET,  
127, 128  
Voltage tests, 158, 159  
VOM, 9, 11  
VTVM, 10, 11

## W

Wattage measurement, 66  
Wattmeters, 16  
"Windshield wiper" effect, 110

## Y

Y amplifier, 96

## Z

Zener diode test, 151  
Zero meter scale, 161





