

*Lawson W. Davis*  
**DIAL CORD**  
*Stringing* **GUIDE**

DC-5

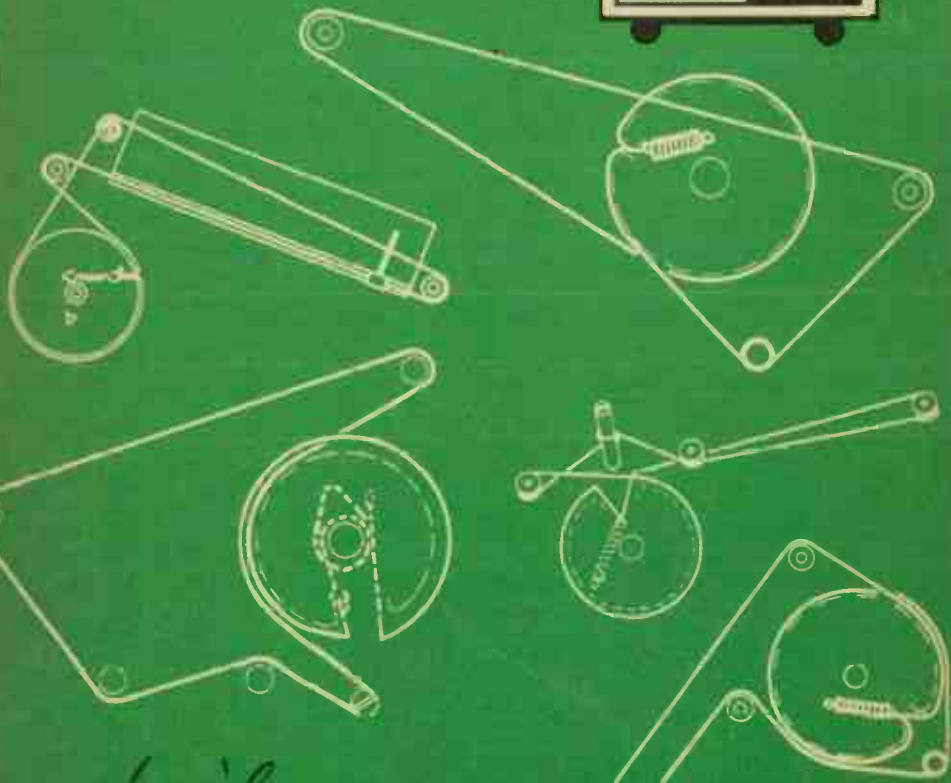

*Lawson W. Davis* **PHOTOFACT PUBLICATION**

Word Books, Inc.

*Howard W. Sams*  
**DIAL CORD**  
*Stringing* **GUIDE**

**DC-5**

FIRST EDITION • FIRST PRINTING • NOVEMBER 1955

Reproduction or use, without express permission, of editorial or pictorial content, in any manner, is prohibited. No patent liability is assumed with respect to the use of the information contained herein.

Entire Contents Copyrighted 1955 by Howard W. Sams & Co., Inc.

Indianapolis, Indiana, U. S. A.

Copyright Under International Copyright Union

All Rights Reserved Under Inter-American Copyright Union (1910)

By Howard W. Sams & Co., Inc.

*Compiled and Published by*  
**HOWARD W. SAMS & CO., INC.**

Indianapolis, Indiana

LITHO

**HOWARD W. SAMS & CO., INC.**

**GRAB BAG**

## PREFACE

This manual, which covers radio and television receivers manufactured from 1953 through mid-1955, is the fifth of the "DIAL CORD STRINGING GUIDE" series. The data presented herein is intended to make easier the service technician's job of restringing a dial cord.

The index lists all receivers which were presented in the previous manuals as well as those covered in this manual. Thus, it is necessary to look in only one place to determine the diagram number which pertains to the receiver being serviced. The diagrams presented in this manual are consecutively numbered, the first one being the next consecutive number after the last number in the preceding manual in the series. This prevents any possible confusion which might result from consulting a diagram in the wrong manual.

The acceptance of the previous manuals in this series has prompted the preparation of this manual in order to make available to the service technician this practical, easy-to-use data.

Name & Model or Chassis No.	Vol. 5 Diag. No.	Previous Vols. Vol. No. Diag. No.	Name & Model or Chassis No.	Vol. 5 Diag. No.	Previous Vols. Vol. No. Diag. No.	Name & Model or Chassis No.	Vol. 5 Diag. No.	Previous Vols. Vol. No. Diag. No.
<b>ADMIRAL</b>			<b>ADMIRAL (Continued)</b>			<b>ADMIRAL (Continued)</b>		
Chassis			4H126A, B, C,			7P32, 7P33,		
UL5K1	2	553	CN, S, SN	3	1065	7P34, 7P35	1	8
UL7C1	1	9	4H137A, B, C,			7RT41, 7RT42,		
3C1	3	1064	CN, S, SN	3	1065	7RT43	2	561
4A1	1	4	4H145A, P, C,			7T01, 7T01M-UL,		
4B1	1	10	CN, S, SN,			7T04, -UL	2	564
4H1, 4J1, 4K1	3	1065	4H146A, B, C,			7T06	1	10
4L1	3	1066	CN, S, SN,			7T10	2	553
4R1	3	1067	4H147 A, B, C,			7T12	1	10
4S1	3	1066	CN, S, SN	3	1065	7T14, 7T15	2	553
4T1	4	1459	4H155A, B, C,			9B14, 9B15,		
4W1	4	1460	CN, S, SN,			9B16	2	562
4Z1	1808		4H156A, B, C,			24X15, S,		
5A3	4	1461	CN, S, SN,			24X16, S,		
5B1, 5B1A	1	5	4H157A, B, C,			24X17S	3	1066
5B2	3	1066	CN, S, SN	3	1065	30F15, A,		
5C3	4	1462	4H166A, B, C,			30F16, A,		
5D2	3	1068	CN, S, SN,			30F17, A,	3	1065
5D3	1809		4H167A, B, C,			32X15, 32X16,		
5E2	4	1463	CN, S, SN	3	1065	32X26, 32X27,		
5E3	1810		4R11, 4R12	3	1067	32X35, 32X36	3	1066
5G2	4	1464	4T11	4	1459	34R15, A,		
5H1	1	8	4W18, 4W19	4	1460	34R16, A,	3	1064
5J2	4	1465	4Z11, 4Z12,			34R37, 34R45,		
5K1	2	553	4Z14, 4Z18,			34R46	3	1068
5L2	4	1466	4Z19	1808		36X35, A,		
5M2	4	1467	5A32/12,			36X36, A,		
5N1	2	554	5A32/15,			36X37, A,	3	1066
5R1	2	555	5A32/16,			37F15, A, B,		
5R2	4	1468	5A33/12,			37F15A, B,	3	1068
5W1	3	1069	5A96/15,			37F27, A, B,		
5X1	3	1070	5A33/16	4	1461	37F28, A, B,	3	1068
5X2	4	1469	5D31, 5D32,			37F35, A, B,	3	1068
5Y2	4	1480	5D33	1809		37F55, 37F56,		
6A1	1	1	5E21, 5E22,			37F57	3	1068
6A2	3	1071	5E23	4	1463	37K16, A, B,		
6C2, A	1811		5E31, 5E32,			37K16, A, B,	3	1064
6E1, 6E1N	1	6	5E33	1810		37K27, A, B,	3	1064
6J2	4	1471	5E36, 5E39	1810		37K35, A, B,		
6L1	2	561	5G21, 5G21/15,			37K36, A, B,	3	1064
6M1	1	7	5G22, 5G22/15,			37K55, 37K56,		
6M2	4	1471	5G23, 5G23/15	4	1464	37K57	3	1064
6Q1	3	1072	5J21, 5J22,			37M15, 37M16	3	1064
6R1	2	556	5J23	4	1465	39X16, A, B,		
6S1	3	1073	5K11, 5K12,			39X17, A, B,	3	1066
6W1	3	1074	5K13, 5K14	2	553	39X35, 39X36,		
7B1	1	2	5L21, 5L22,			39X37	3	1064
7C1	1	9	5L23	4	1468	47M15, 47M16,		
7E1	2	558	5M21, 5M22	4	1467	47M17	4	1473, 1474
7G1	2	560	5R10, 5R11,			121M10, 121M11A,		
9A1	2	559	5R12, 5R13,			121M12A	4	1473, 1474
9B1	2	562	5R14	2	555	221K45A,		
10A1	1	3	5S21AN,			221K46A,		
15HF1	1812		5S22AN,			221K47A	4	1473, 1474
19D2, A	1813		5S23AN	4	1462	222DX15S,		
19E1 (Radio Ch.)	4	1472	5W11, 5W12	3	1069	222DX16,		
19E2, A,			5X11, 5X12,			222DX17,		
19G1, A	1813		5X13, 5X14	3	1070	222DX26,		
19N1 (Radio Ch.)	4	1472	5X21, 5X22,			222DX27,		
19P1	1813		5X23	4	1469	222DX46,		
20D2	1814		5Y22	4	1470	222DX49,	4	1475
21C3Z	1815		6A21, 6A22,			321DX15, A,		
21W1 (TV Ch.)	4	1473	6A23	3	1070	321DX16, A,		
21W1 (Radio Ch.)	4	1474	6C22, A,			321DX17, A,	4	1472
22A2, 22A2A			6C23, A,	1811		321DX15L,		
(TV Ch.)	4	1473	6C71	1	3	321DX16L,		
22A2, 22A2A			6J21, 6J22	4	1471	321DX17L	4	1472
(Radio Ch.)	4	1474	6N25, 6N26,			321DX25E,		
22C2, 22E2	4	1475	6N27	4	1469	321DX26, B,		
22M1 (TV Ch.)	4	1473	6P32	1	6	321DX27B	4	1472
22M1 (Radio Ch.)	4	1474	6Q11, 6Q12,			321F15,		
22P2	1816		6Q13, 6Q14	3	1072	321F16,		
22Y1 (TV Ch.)	4	1473	6R11	2	556	321F18	3	1068
22Y1 (Radio Ch.)	4	1474	6RT41, A,			321F27,		
			6RT42, A,			321F35,		
			6RT43, A,	1	5	321F36,		
			6RT44	1	2	321F46,		
			6S11, 6S12	3	1073	321F47,		
			6T01	1	5	321F49	3	1068
			6T02, 6T03	1	5	321P65, 321P66,		
			6T06, 6T07	1	4	321P67	4	1473, 1474
			6T11	1	5	321K15, 321K16,		
			6T12	1	4	321K18, 321K27,		
			6T44A	1	2	321K35, 321K36,		
			6W11, 6W12	3	1074	321K46, 321K47,		
			7C61, 7C62, A,			321K49, 321K65,		
			7C22UL	1	7	321K66, 321K67	3	1064
			7C63, A,			321M25A,		
			7C63U,	1	9	321M26A,		
			7C65B, M, W,	2	558	321M27A	4	1473, 1474
			7C63	2	559	322DX16	4	1475
			7G11, 7G12,					
			7G14, 7G15,					
			7G16	2	560			

Name & Model or Chassis No.	Vol. 5 Diag. No.	Previous Vols. Vol. No. Diag. No.
<b>ADMIRAL (Continued)</b>		
321DX16A	1816	
421M15A,		
421M16A,		
421M35,		
421M36,		
421M37	4	1473 1474
520M11,		
520M12,		
520M15,		
520M16,		
520M17	4	1473, 1474
521M15A,		
521M16A,		
521M17A	4	1473, 1474
<b>AEROMOTIVE</b>		
181-AD	1	11
<b>AIRADIO</b>		
SU-41D,		
SU-52A, B, C	1	12
3100	2	583
<b>AIRCASLE</b>		
C-300	3	1075
G-516, G-518	2	584
G-521	2	585
G-724	2	586
G-725	2	587
REV-248	3	1076
PX	1	13
WEU-262	3	1077
9	2	568
102B	3	1078
106B	1	11
171, 172	3	1080
198	3	1081
201	3	1082
350	3	1083
472.254	4	1476
568	1	14
572	2	569
602-182144	3	1084
602-PR-8.1	3	1085
606-400WB	3	1086
607-314, 315	2	1087
610.C351	4	1477
610.CL152B, M	4	1478
610.F100	4	1479
610.F151	4	1480
610.H400	4	1481
610.P-651.1	4	1481
610.S500	4	1480
610.W-100	1817	
651	1	15
652.5T5E, V	1818	
652.5X5	1819	
652.6T1E, V	4	1482
652.8T1F1	1820	
735.5400, UL	1821	
782. PM-99-AC	1822	
5000, 5001	1	11
5002	1	16
5003, 5004,		
5005, 5006	1	17
5008, 5009	2	570
5010, 5011, 5012	1	18
5015.1	3	1088
5020	1	16
5022	3	1089
5024	2	571
5025	2	572
5025	2	573
5028, 5029	2	574
5036	3	1090
5044	3	1091
6050	3	1092
6053	3	1093
6514, 6541,		
6544	1	15
6547	1	15
6611, 6612, 6613,		
6630, 6631, 6632,		
6634, 6635	1	19
7553	2	575
9091	3	1094
10002	2	576
10003-1	2	560
108014, 108504	2	577
121104	3	1095

Name & Model or Chassis No.	Vol. 5 Diag. No.	Previous Vols. Vol. No. Diag. No.
<b>AIRCASLE (Continued)</b>		
127084	2	578
131504	2	579
138104	2	578
139144	2	580
149654	3	1096
150084	3	1097
<b>AIR CHIEF (See Firestone)</b>		
<b>AIR KING</b>		
A-501, A-502	2	581
A-510	2	574
A-511, A-512	2	582
A-600	2	583
A-604	3	1098
A-625	2	583
A-650	2	584
17K1C	4	1483
4601	1	30
4603	1	31
4604, D	1	34
4607, 4608	1	32
4609, 4610	1	30
4700	2	585
4704	1	37
4705, 4706	1	35
4708	1	37
<b>AIR KNIGHT</b>		
CA500	1	6
N5-RD291	1	6
<b>AIRLINE</b>		
GSE-1606A,		
GS-1607A	1823	
GSL-1581A,		
GSL-1582A,	1824	
WG-1572C	1825	
04BR511A,		
04BR512A	1	40
04BR515A, B	1	43
04WG468	1	38
04WG568,		
04WG569, B	1	39
04WG619, 04WG621,		
04WG621N1	1	41
04WG672	1	42
04WG673,		
04WG674	1	44
04WG695	1	45
04WG727,		
04WG728,		
04WG732	1	45
04WG800	1	44
04WG804	1	45
04WG1108A	1	46
05GSE-3030A,		
B, C	3	1099
05GSE-3037A,		
-3042A	3	1099
05WG-1813A	3	1100
05WG-2748 F,		
05WG-2749D	3	1101
05WG-2752	3	1102
05WG-3038A,		
-3045A	3	1103
14BR74	1	48
14BR521A,		
14BR522A	1	40
14BR523A	1	48
14BR613A	1	48
14BR624A	1	48
14BR147	1	48
14WG469	1	47
14WG518,		
14WG519,		
14WG510B,	1	6
14WG511B	1	49
14WG524A,		
14WG525A		
14WG628A	1	11
14WG680	1	42
14WG683A	1	51
14WG690	1	50
14WG737	1	52
14WG739	1	47
14WG740,		
14WG741	1	52
14WG756,		
14WG757	1	56
14WG808B, MA,		
14WG808W, WA	1	56
14WG1202B,		
14WG1203B, M, W.	1	54

Name & Model or Chassis No.	Vol. 5 Diag. No.	Previous Vols. Vol. No. Diag. No.
<b>AIRLINE (Continued)</b>		
15BR-1536B,		
15BR-1537B	4	1485
15BR-1543A, B		
15BR-1544A, B	4	1486
15BR-1547A	4	1487
15BR-1548A,		
15BR-1549A	4	1488
15BR-2756B,		
15BR-2757A	4	1489
15BR-3035A	4	1490
15GSE-2764A	4	1491
15WG-1545A, B,		
15WG-1546A, B	4	1492
15WG-2745C	3	1104
15WG-2749E, F,		
15WG-2752D, E	4	1493
15WG-2758A	4	1494
15WG-3050A, B	4	1495
25BR-1542A	4	1496
25BR-3058A, B,		
25BR-3061A,		
25BR-3067A,		
25BR-3068A,		
25BR-3069A	4	1497
25GHM-1073A	1826	
25GSE-1555A,		
B, 25GSE		
-1556B,		
25GSE-1557B	4	1498
25GSE-3065A	4	1499
25GSL-1814A	4	1500
25WG-1570A, B,		
C, 25WG-1371A,		
B, 25WG-1572A,		
B	4	1501
25WG-1573A	4	1502
25WG-2758B	4	1494
25WG-2758C, D	4	1503
25WG-2765D, E	4	1494
25WG-2766A, B	4	1503
25WG-3060A	4	1504
25WG-3070A	4	1504
35BR-1557A,		
35BR-1558A,		
35BR-1559A	1827	
35BR-3158A,		
35BR-3167A,		
35BR-3168A,		
35BR-3169A	1828, 1829 1830	
35BR-6796A	1829	
35GHM-1073	1830	
B, C	1826	
35GHM-1074	1831	
A	1831	
35GSE-1555C,		
35GSE-1556C	4	1498
35GSL-2770A	1832	
35WG-1573B	1833	
35WG-2767A	2103	
35WG-3171A,		
B, 35WG-3173		
A, B, 35WG		
-3175A,		
35WG-3177A,		
35WG-379A	1834	
45BR-3186A	2031	
54BR1501A		
54BR1502A	1	40
54BR1503A,		
B, C	1	58
54BR1504A,		
B, C	1	58
54BR1505A, B	1	55
54BR1506A, B	1	55
54KPI209A, B	1	6
54WG1801A, B	1	53
54WG2007A, B	1	6
54WG2500A,		
54WG2700A	1	57
61-6787	1835	
61-6792	1836	
61-6793	1919	
61-6794	1856	
61-6795	1857	
61-12601	1858	
62-123	1	11
62-131, -133	1	11
62-142	1	11
62-144	1	11
62-152	1	11
62-158	1	11
62-237	1	11
62-239	1	11
62-270	1	59
62-292	1	11

Name & Model or Chassis No.	Vol. 5 Diag. No.	Previous Vols. Vol. No. Diag. No.	Name & Model or Chassis No.	Vol. 5 Diag. No.	Previous Vols. Vol. No. Diag. No.	Name & Model or Chassis No.	Vol. 5 Diag. No.	Previous Vols. Vol. No. Diag. No.
<b>AIRLINE (Continued)</b>			<b>AIRLINE (Continued)</b>			<b>ARIA</b>		
82-294	1	11	94BR-2740A,			554-1-61A	1	79
82-303	1	59	-2741A, P	3	1108	<b>ARTHUR ANSLEY</b>		
82-309	1	59	94GAA3654A	3	1109	R-1	4	1508
82-321	1	59	94GSE-2735A,			<b>ARTONE</b>		
82-347	1	59	-2736A	3	1110	524	3	1121
82-373, -374	1	11	94WG-1509A	3	1111	<b>ARVIN</b>		
82-417	1	59	94WG-1804D	3	1112	Model		
82-443	1	59	94WG-1811A	3	1113	15-550KB-UHF. 1842		
82-447	1	59	94WG-2742A,			21-550KB,		
82-449	1	59	C, D	3	1114	KMU,		
82-451	1	59	94WG-2745A	3	1115	21-551TBU,		
82-471, 472	1	61	94WG-2746A, B,			TMU,		
82-704, -705,			-2747A	3	1114	21-552KBU,		
-706, -707, -708,			94WG-2748A, C,			KMU,		
-709, -710, -711,			94WG-2749A	3	1118	21-553TBU,		
-712	1	60	94WG-3008A	3	1117	TMU	1844	
82-752, -753	1	64	94WG-3016A,			140P	2	606
82-901	1	64	B, C	3	1117	150TC	2	607
82-910	1	60	94WG-3028A	3	1117	152T, 153T	2	608
64BR1051A, B	1	62				160T, 161T	2	609
64BR1205A,			<b>ALGENE</b>			182T FM	2	610
64BR1206A	1	65	ARSU	2	555	240P, 241P, 244P	2	611
64BR1208A	1	63	ARBU	2	555	250P	2	612
64BR1503, P	1	58	<b>ALLIED RADIO (See Knight)</b>			280T FM, 281T FM	2	614
64BR1504, B	1	58	<b>ALLSTATE</b>			350-PB, -PL,		
64BR1513A, P	2	586	Model			351-PB, -PL,		
64BR1514A, B	2	586	6240	1837		352-PL, 353-PL	3	1122
64BR1808A	1	66	5264, 6266	1838		355T, 356T, 357T	3	1123
64BR2200A	1	63	6284	1839		358T	2	608
64BR2701A	1	66	6286-4,			450T, 451T	3	1124
64WG1052A	1	67	6287-4	1840		460T, 461T	3	1125
64WG1207B	1	69	6330	1841		462-CB, 472-CM	3	1126
64WG1511A, B	1	68	<b>Chassis</b>			480T FM,		
64WG1512A, B	1	68	528, 6264			481T FM	3	1127
64WG1801C	1	6	528, 6266	1838		482CFB, 482CFM	3	1128
64WG1804A, B, C	1	71	528, 6284	1839		547, A	2	614
64WG1807A, B	1	71	528, 6286-4,	1840		551T	4	1590
64WG1809A, B	1	68	528, 6240	1837		552AN, N	1	77
64WG2007A, B	1	6	528, 6330	1841		553	4	1510
64WG2009A, B	1	68	<b>ALTEC LANSING</b>			554CCB, 554CCM	4	1509
64WG2010B	1	68	ALC-101	3	1118	555, A	1	77
64WG2500A	1	57	303A	4	1505	558	1	81
64WG2700A, B	1	57	<b>AMC</b>			580T FM	4	1511
74BR1513B	2	586	20CD2B, 20C2B,			581T FM	1845	
74BR1514B	2	586	2072B, 21CD2A,			582CFB, 582CFM	4	1512
74BR2001A, B	2	587	21C2A	2007		650-P	4	1513
74BR2701A	2	588	125P			651T	4	1513
74KR1210A	2	589	128	1	82	652-P, 654-P	4	1513
74KR2706B	2	590	<b>AMERICAN COMMUNICATIONS (See Liberty)</b>			655WV	4	1511
74KR2713A	2	591	<b>ANDREA</b>			657-T	4	1514
74WG1052B	1	67	BT-VK12	3	1119	664, A	1	6
74WG1056A	2	593	C-VN21	1842		685	1	83
74WG1207B	1	69	CO-U15	2	602	753T	1	1847
74WG1509A,			CO-VK15,			758T	1	1848
74WG1510A,	2	594	CO-VK16	3	1120	760T	1	1849
74WG1511B,			CO-VK18	3	1119	780T FM	1	1845
74WG1512B	1	68	CO-VL19	4	1506	857T	1	1850
74WG1802A,			CO-VL125	3	1119	858T, 859T	1	1851
74WG1803A	2	595	CO-VL126	3	1119	2120CM,		
74WG1804C	1	71	T-16	2	603	2121TM,		
74WG1807A, B	1	71	T-U15	2	602	2123TM,		
74WG2002A	2	594	T-VK12	3	1119	2124CCM,		
74WG2004A	2	595	T-VN21	1842		2126CM	3	1129
74WG2007B, C	1	6	TVK-127B, M	3	1119	2160, 2161,		
74WG2010B	1	68	2C-VN21	1842		2182, 2164	3	1130
74WG2500A	1	57	<b>ANSLEY</b>			2410P	2	611
74WG2504A, B, C	2	596	Model 53	2	604	4080T, 4081T	3	1131
74WG2505A	1	70	<b>APX</b>			6173TM-UHF,		
74WG2700A	1	57	4B5	2	574	6213TB-UHF,		
74WG2704A, B, C	2	596	<b>APPROVED ELECTRONIC INSTRUMENT CORP.</b>			6213TM-UHF,		
74WG2709A	2	597	FM Tuner	2	605	6215CM-UHF,		
84GA A3987A	3	1105	A-710	4	1507	6640	4	1515
84HA 1529A,			<b>ARCADIA</b>			7210CB-UHF,		
84HA 1530A	3	1106	World Radio History			7210CM-UHF,		
84KR1520A	2	592	37D14-800	1	78	7212CFP-UHF,		
84WG2015A	2	598				7212MEU-UHF,		
84WG2506	2	601				7214CM-UHF,		
84WG2506B	2	599				7216CB-UHF,		
84WG2712A, B	2	600				7218CB-UHF,		
84WG2714A, F,						7218CM-UHF,		
G, H, J	2	601				7219CM-UHF,	4	1515
84WG2718A, B	2	600				7278CB-UHF		
84WG2720A	2	600				7279CM-UHF, F	1852	
84WG2721A, B	2	601				9210CB-UHF,		
84WG2724A	2	600				9210CM-UHF, F	1852	
84WG2728A	2	600				9211TB-UHF	1853	
84WG2732A, B	2	600				9212CFP-UHF,		
84WG2734A	2	600				9212MEA-UHF	1852	
93WG510	1	72						
93WG754, 93WG755	1	74						
93WG800	1	74						
93WG1108	1	80						
93WG1109	1	80						
93WG1104	1	80						
93WG1110	1	80						
93WG1103	3	1107						

Name & Model or Chassis No.	Vol. 5 Diag. No.	Previous Vols. Vol. No. Diag. No.	Name & Model or Chassis No.	Vol. 5 Diag. No.	Previous Vols. Vol. No. Diag. No.	Name & Model or Chassis No.	Vol. 5 Diag. No.	Previous Vols. Vol. No. Diag. No.
<b>ARVIN (Continued)</b>			<b>AUTOMATIC (Continued)</b>			<b>BENDIX (Continued)</b>		
9213TM-UHF,			DM-132.....	1836		526MA, MB, MC.....	2	631
9215CM-UHF..	1853		F-100.....	3	1133	613.....	2	632
9216CB-UHF,			F-151.....	4	1522	626A.....	1	97
9218CB-UHF,			M-86.....	2	618	636A, B, C.....	1	98
9218CM-UHF,			P-851.....	4	1523	646A.....	1	99
9219CM-UHF..	1852		PM-236.....		1856	656A.....	1	100
9240CB-UHF,			MM-430.....		1857	676B, C, D.....	1	101
9240CM-UHF..	1852		S-551.....	4	1522	697A.....	2	633
9245CM-UHF..	1853		TR-12.....		1858	736B.....	1	100
			TV-P490.....	3	1134	753F, M, W.....	4	1526
<b>Chassis</b>			TV-1649.....			847B, S.....	2	634
RE-202.....	1	77	TV-1850.....			951, 951W.....	3	1135
RE-204.....	1	81	TV-1851.....	4	1524	1217, E.....	2	635
RE-206, -1, -2.....	2	6	601, 602 (Series A).....	1	73	1217D.....	2	636
RE-209.....	2	606	612X, 613X (Series B).....	2	555	1518, 1519.....	2	637
RE-213.....	3	1123	614X, 616X.....	1	78	1521, 1525.....	2	637
RE-228, -1.....	2	607	820.....	1	86	1524, 1525.....	2	637
RE-229.....	1	83	825.....	1	87	1531.....	2	638
RE-231.....	1	77	640 (Series B).....	1	73	1533.....	2	638
RE-232.....	2	609	660, 662, 666.....	2	619	6100.....	3	1136
RE-233.....	2	608	720.....	2	620			
RE-237.....	2	610				<b>Chassis</b>		
RE-242.....	2	614	<b>AVIOLA</b>			C-19.....	4	1526
RE-243, RE-244.....	2	611	509.....	1	88	T14-3, T14-10.....	4	1525
RE-246.....	2	612	601.....	1	89	-11.....	4	1525
RE-253.....	2	613	608.....	1	91			
RE-264, -255, -256, -259.....	2	611	612.....	1	89	<b>BLONDER TONGUE</b>		
RE-267-1, -2.....	3	1122	618.....	1	91	BTU-2.....		1862
RE-273.....	3	1123				<b>BREWSTER</b>		
RE-277, RE-277-1.....	3	1127	<b>BELL SOUND</b>			9-1084, 9-1085, 9-1086.....	1	103
RE-277-2.....	3	1122	PA-3715-B.....					
RE-281.....	3	1124	PA-3725-B.....					
RE-284.....	3	1125	PA-3750-B.....	1859		<b>BROOKS LABORATORIES, INC.</b>		
RE-287-1.....	3	1126	2210.....	1860		ST10.....	4	1527
RE-288-1.....	3	1128	2255.....	1861		ST-10A.....	1863	
RE-292.....	4	1513	3715.....	2	621	ST-14A.....	4	1527
RE-297.....	4	1509	3715-B.....	1859		ST-15A.....	1864	
RE-306.....	4	1509	3725.....	2	621	<b>BROWNING</b>		
RE-307.....	4	1514	3725-B.....	1859		PF-12.....	2	639
RE-308.....	4	1510	3728.....	2	621	RJ-12.....	2	639
RE-310.....	4	1512	3750.....	2	621	RJ-12B.....	4	1528
RE-313.....	4	1511	3750-B.....	1859		RJ-12A.....	2	640
RE-323.....	1846					RJ-14A.....	2	640
RE-327.....	4	1511	<b>BELLTONE</b>			RJ-20A.....	3	1137
RE-333.....		1845	500.....	1	90	RJ-42.....	1865	
RE-342.....		1849	<b>BELMONT</b>			RJ-43.....	1866	
RE-348.....		1847	A8D110.....	1	94	RJ-48.....	1867	
RE-350.....		1848	4B17.....	1	93	RJ-49 (AM).....	1867	
RE-374.....		1851	4B112, 4B113.....	1	65	RJ-49 (FM).....	1868	
RE-378.....		1850	4BA1, 4BA2.....	1	48	RV-10.....	2	641
TE-282.....	3	1131	5D16.....	1	48	RV-10A.....	3	1138
TE-289-2, -3.....	3	1129	5D110.....	2	622	RV-11.....	2	641
TE-290.....	3	1130	5D128.....	1	96	RV-31.....	4	1529
TE-330, TE-332.....	4	1515	5DA1.....	1	48	RV-32.....	1869	
TE-340, -1, -2.....	1852		5P19.....	1	95			
TE-341, -2.....	4	1515	6D111 (Series A & B).....	1	92	<b>BRUNSWICK</b>		
TE-395, -1.....	1852		6D120.....	2	623	A1020.....	1	102
TE-392.....	1853		8A59.....	1	96	A2020.....	1	102
TE-393, -1, -2, -3.....	1852		533 (Series P & Q).....	1	43	A2600.....	1	102
TE-373.....	1853		716.....	1	48	A2700.....	1	102
TE-379.....	1844					A3720.....	1	102
<b>ASTATIC</b>			<b>BENDIX</b>			BJ683.....	2	642
CB-1.....	1854		FB21CU.....	4	1525	C-3309.....	2	642
UHF.....	1855		FM21C, FM21CU.....	4	1525	D-1000, D-1100.....	2	643
<b>ATLAS</b>			FM27C.....	4	1525	D-6876.....	2	644
AB-45.....	1	73	HB21C, HB21CU.....	4	1525	T-4000, T-4000 1/2.....	2	644
<b>AUDAR</b>			HB27C, HM21C, HM21CU.....	4	1525	T-6000, S, SS, SX, T-6000 1/2.....	2	644
AV-TT.....	4	1516	KM21CU.....	4	1525	T-9000.....	2	643
PR-6.....	1	84	PAR-80.....	2	624	512, 513, 812, 816.....	4	1530
PR-6A.....	1	85	TE21CU, TE24DS, TM47C, TM21CU, TM24DS, DU.....	4	1525	1880.....	1	107
<b>AUTOMATIC</b>			0526, 0526A, B, C, D, E, F.....	1	97	1700.....	1	102
Tom Boy.....	2	555	0626A.....	1	97	2600.....	1	107
Tom Thumb Buddy.....	2	615	55L2, 55L3.....	2	625	2899.....	1	107
Tom Thumb.....			55P2, 55P3.....	2	625	5000.....	2	645
Camera-Radio.....	2	616	55P4.....	2	626	5125, 6165, 6185, 8165.....	4	1530
Tom Thumb Jr.....	2	555	75B5, 75M5, 75MB, 75P6.....	2	629	<b>BUICK</b>		
B-44.....	2	616	75W5.....	2	628	980690, 980733.....	1	104
C51.....	4	1517	95B3, 95M3, 95M9.....	2	628	980744, 980745.....	1	104
C54.....	4	1518	110, 110W, 111, 111W, 112.....	2	625	<b>BUTLER BROS. (See Air Knight or Skyrover)</b>		
C-80.....	1	86	114, 115.....	2	625	<b>CAPEHART</b>		
C-80X.....	2	555	300, 300W.....	2	627	C-14.....	1870	
C-300.....	3	1075	416A.....	2	630	P-213.....	1871	
C-351.....	4	1519						
CL-152B, M.....	4	1580						
CM-333.....	1919							
D-200.....	3	1132						
D-25J.....	4	1521						

Name & Model or Chassis No.	Vol. 5 Diag. No.	Previous Vols. Vol. No. Diag. No.
<b>CAPEHART (Continued)</b>		
RP-152		4.....1531
RP-153	1872	
RP-154E, M	1873	
RP-254	1872	
T-54	1874	
T-522		4.....1532
1T174B-1,		
BS-1, M-1,		
MS-1, S-1,		
1T174-1,		
2T214D-1,		
BS-1, D-1,		
MD-1, MS-1,		
M-1, S-1,		
2T214-1,		
4C174M-1,		
MS-1,		
5C214B-1,		
D-1, MD-1,		
M-1,		
5C214-1,		
7H214B-1,		
D-1, M-1,		
7H214-1,		
9F214BD-1,		
MD-1,		
9F214-1,		
11F244B-1,		
M-1,		
11F244-1	1875	
11RP-125F	1873	
12F274M-1,		
14W214-1,		
15W214BD-1,		
MD-1,		
15W214-1,		
16T244BS-1,		
ES-1, M-1,		
MS-1, S-1,		
16T244-1,		
18W214FD-1,		
19C214M-1,		
MD-1,		
21T214ES-1,		
23C214B-1,		
M-1	1875	
35P7		3.....1139
325F, M, 326M,		
332B, M, 334M		3.....1140
1005B, M, W		3.....1141
1006B, M, W		3.....1141
1007AM		4.....1533
3011B, M,		
3012B, M		3.....1140
Chassis		
C-318		4.....1533
CR-85	1871	
CR-129	1873	
CR-147	1872	
CT-27, CT-38,		
CT-45		4.....1534
CT-108, CT-110,		
CT-112, CT-116,		
CT-123, CT-124,		
CT-127, CT-129,		
CT-131, CT-134,		
CT-144, CT-146	1875	
CX-37-1 Series	1875	

<b>CAVALIER</b>		
6A2	1876	
<b>CBS COLUMBIA</b>		
22K58	1877	
2001(UHF Conv.)		4.....1535
<b>CENTURY (20th)</b>		
100X, 101, 104		1.....73
<b>CHANCELLOR</b>		
35P		2.....574

<b>CHEVROLET</b>		
985538		1.....105
985696		1.....108
985697		1.....106
985792		1.....109
985793		1.....110
985794		1.....106
986146		2.....646
986516		4.....1536

Name & Model or Chassis No.	Vol. 5 Diag. No.	Previous Vols. Vol. No. Diag. No.
<b>CHEVROLET (Continued)</b>		
986669	1878	
986771	1879	
987088	1880	

<b>CHRYSLER (See Mopar)</b>		
<b>CISCO</b>		
1A5		2.....574
9A5		1.....73

<b>CLARION</b>		
C100, C101		1.....111
C102		1.....113
C103, C104, C105		1.....116
C105A		1.....90
C108		1.....113
11011		1.....115
11305		1.....90
11801, 11802V-M		2.....647
12110M		2.....648
12310W		2.....649
12708		2.....619
13101		2.....579
14601		2.....574

<b>CLEARSONIC</b>		
5C66		1.....11

<b>COLLINS AUDIO PRODUCTS</b>		
FMA-6		3.....1142
45-D		3.....1143

<b>COLLINS RADIO</b>		
75A-1		2.....850
75A-2		4.....1537

<b>COLONIAL</b>		
629		1.....112
671, A		1.....112

<b>CONCORD</b>		
CD61P		1.....79
6C51B, W		1.....6
6D51B		1.....117
6D51W		1.....117
6D61B		1.....120
6D61P		1.....79
6D61X		1.....120
6D62W		1.....114
6E51B		1.....18
6F28W		1.....119
6T81W		2.....555
7G28C		1.....38
1-402, 1-403		2.....614
1-411		2.....574
1-501		1.....18
1-504		2.....851
1-509, 1-510		1.....6
1-516, 1-517		2.....652
1-801, L-802,		
1-603		1.....38
1-606		2.....568
1-608		1.....119
1-609		2.....555
1-611		2.....653
1-1201		2.....654

<b>CONTINENTAL</b>		
A-11, A-11PH		1.....118
B6		1.....122
B11		1.....118
L5		1.....122
XB6		1.....122
XL5		1.....122

<b>CO-OP</b>		
8AWC2, 8AWC3		2.....655
6A47WC,		
6A47WT,		
6A47WTR		2.....655

<b>CORONADO</b>		
RA33-9856D	1881	
05RA1-43-7755A		
05RA1-43-7755A		1.....1144
05RA1-43-9901A		3.....1145

Name & Model or Chassis No.	Vol. 5 Diag. No.	Previous Vols. Vol. No. Diag. No.
<b>CORONADO (Continued)</b>		
05RA2-43-8230A		4.....1538
05RA2-43-8515A		3.....1146
05RA-43-9876A		3.....1147
05RA37-43-8360A		3.....1148
15RA1-43-7654A		4.....1639
15RA1-43-7902A		3.....1149
15RA33-43-8365		4.....1540
15RA37-43-9230A		4.....1540
15TV1-43-8958A,		
B, 15TV1-43-		
9020A, B, 15TV1-		
43-9021A, B		4.....1541
15TV2-43-9101A,		
15TV2-43-9102A,		
(Radio Ch.)		4.....1542
15TV4-43-8948A,		
15TV4-43-8949A,		
35TV2-43-		4.....1543
35RA2-43-5101A		4.....1544
35RA4-43-		
9856A	1883	
35RA37-43-		
8355	1884	
35TV2-43-		
9023B	1885	
35TV2-43-		
9050A		
35TV2-43-		
9061A	1835	
43-5005		2.....656
43-631		1.....13
43-6451		1.....124
43-6485		2.....657
43-7601,		
43-7601B		1.....38
43-7602		1.....38
43-7651,		
43-7652		1.....66
43-7851		2.....599
43-8160		1.....121
43-8180		1.....11
43-8213		1.....124
43-8240, 43-8241		1.....127
43-8305		1.....71
43-8312A		1.....68
43-8330		1.....123
43-8351, 43-8352		1.....126
43-8353, 43-8354		2.....658
43-8420		2.....659
43-8470		1.....71
43-8471		1.....68
43-8576		1.....71
43-8685		1.....125
43-9196		1.....128
43-9201		2.....622
45RA1-43-		
7866A	1885	
45TV2-43-		
9023B	1834	
45TV2-43-		
9061B,		
45TV2-43-		
9064A	1834	
45TV13-43-		
9038A,		
45TV13-43-		
9081A	1886	
94RA1-43-		
7656A,		
94RA1-43-		
7657A		3.....1150
94RA1-43-		
7751A		3.....1151
94RA1-43-		
8510A,		
94RA1-43-		
8511A		3.....1152
94RA1-43-		
8510B,		
94RA1-43-		
8511B		3.....1153
94RA31-43-		
9841A		3.....1154
94RA33-43-		
8130C,		
94RA33-43-		
8131C		3.....1155
7656A, 7657A		3.....1150
7751		3.....1151
7755A, B		3.....1144
7901A		3.....1145
7902A		3.....1149
8130C, 8131C		3.....1155
8360A		3.....1148
8510A, 8511A		3.....1152
8510B, 8511B		3.....1153
8515		3.....1146
9841A		3.....1154
9876A		3.....1147



Name & Model or Chassis No.	Vol. 5 Diag. No.	Previous Vols. Diag. No.
--------------------------------	------------------------	--------------------------------

Name & Model or Chassis No.	Vol. 5 Diag. No.	Previous Vols. Diag. No.
--------------------------------	------------------------	--------------------------------

Name & Model or Chassis No.	Vol. 5 Diag. No.	Previous Vols. Diag. No.
--------------------------------	------------------------	--------------------------------

**CORONET**

C-2		130
-----	--	-----

**CRAFTSMEN (Also See Radio Craftsmen)**

C900	1827	
C1000	1888	

**CROMWELL**

1020		1156
------	--	------

**CROSLEY**

D-25BE, CE, GN, MN, TN, WE		1545
DU-17CDB, CDM, CHB, CHM, CHN, (Ch. 356-1, -2)		1548
DU-17CDB, CDM (Ch. 1-356-3, -4)		1546
DU-17CHN1		1546
DU-17COB, COM, (Ch. 356-1, -2)		1546
DU-17COL, COM (Ch. 356-3, -4)		1546
DU-17PDB, PDM, PHB, PHM, PHN, PHNI		1547
DU-17TOB, TOL, TO11, TOM		1546
DU-20CDM, CHB, COB, COM		1546
DU-21CDM1, CDN, CHM, COB, COL, COLB, COM, E10BE, CT, RD, WE		1548
E15BE, CE, SL, TN, WE		1549
E30BE, GN, MN, TN		1550
EU-17COM, TOB, TOM		1546
EU-21CDB, CDM, CDN, COBA, COMa		1546

F-17TOLBU, F-17TOLU	1889	
F-21CDLBU, F-21CDLU, F-21COLBU, F-21COLU	1889	
F-21TOLBU, F-21TOLU	1889	
F-24CDPU, F-24CDMU, F-24COLU	1889	
F-27COBU, F-27COMU	1889	
G-17TOBU, G-17TOMU, G-17TOWU	1890	
G-21TOBU, G-21TOMU	1890	
H-21COBU, H-21COMU, H-21COWU, H-21HCBU, H-21HCWU	1890	

9-101, 9-102	2	660
9-103, 9-104W	2	661
9-113, 9-114W	2	661
9-117	2	595
9-118W	2	660
9-119, 9-120W	2	560
9-121, 9-122W	2	662
9-201, 9-202M,		
9-203E	2	663
9-207M	2	664
9-209	2	665
9-212M,		
9-213B	2	665
9-302	2	666
10-135, 10-135E,		
10-137, 10-138,		
10-139, 10-140	3	1157
10-307M, 10-308,		
10-309	3	1158

**CROSLEY (Continued)**

11-100U, 11-101U, 11-102U, 11-103U, 11-104U, 11-105U	3	1159
11-106U, 11-107U, 11-108, 11-109U	4	1549
11-128U, 11-127U, 11-128U, 11-129U	3	1160
11-207MU, 11-208BU	4	1551
11-550MU, 11-560BU	4	1549
46FA, 46FB, 56FA, 56FB, 56FC	2	595
56PA, 56PB, 56TA, 56TB-L, 56TC, 56TC-L	1	11
56TD	1	73
56TG	2	667
56TJ	1	131
56TK	1	129
56TL-L, 56TN, 56TN-L, 56TP	1	73
56TR	2	668
56TR, 56TS	1	133
56TU	1	131
67TW	1	73
68CP, 68CR, 68TA, 68TW	2	670
68TC	2	660
86CR, 86CS	1	132
87CU	2	671
88CR	2	671
88TA, 88TC	2	672
106CS	1	66
146CS, 148CP, 148CU	2	673
15492T (UH F Conv)	4	1552

Chassis		
10E, 10E-1	4	1548
15-20E	4	1549
30E, 30E-1	4	1550
28S	3	1157
301	3	1159
302	4	1549
311	4	1545
312	3	1160
356-1, -2, -3, -4	4	1546
357, -1	4	1546
359, 360, 361, 402-1, 403-1, 404-1, 411-1, 412-1, 416-1	4	1546
426, 431, -2	4	1890

**DALBAR**

100	1	134
400	1	11
1000	1	134
Barcombo Jr.	1	134
Barcombo Sr.	1	134

**DAVID BOGEN**

AM901	4	1553
FM400A	1891	
FM801	4	1553
R300	1892	
R501	2	567
R-604	4	1553
R701	1893	
R750	1894	
RR500	1892	
UCT	1895	
UCT-1	1896	

**DEARBORN**

100	2	614
-----	---	-----

**DELCO**

R1175	1	135
R1176, R1177	1	136
R1178, R1179	1	139
R1181	1	136
R1206, R1207, R1208, R1209	1	138
R1212	1	140
R1214	1	140
R1216, R1217	1	141
R1227, R1228, R1229	1	142
R1230A, R1231A, R1232A	1	73
R1233	1	74

**DELCO (Continued)**

R1234, R1235	1	143
R1236, R1237	2	674
R1238	2	574
R1242	2	669
R1243	2	675
R1244, R1245, R1246	2	676
R1251, R1252, R1258, R1254, R1255	2	677
R1408	1	73

**DETROIT**

554	1	79
558, 558-1-40A	1	145
568, 568-13-221D	1	14
571, 571A, 571AL, 57AX, 571B, 571BL, 571BX, 571L, 571X	1	117
572	1	144
572-220-226A	1	114
576, 576-1-6A	1	144
579	1	120
582	1	14
610A, 611A	2	678
7158	2	679
7270	1	146

**DEWALD**

A500, A5001, A500W	1	148
A501, A502, A503	1	148
A504, A505	1	149
A507	2	680
A509	2	681
A514	2	682
A602, A605, A608	1	150
B-400	2	682
B-402	2	683
B-403	2	627
B-504	2	684
B-506	2	685
B-510, B-512	2	686
B-612	2	687
B-614	2	688
D-E517A	4	1554
D-508	3	1161
D-517	3	1162
D-518	3	1163
D-519	2	685
D-616	3	1164
DT-120, DT-122	3	1165
DT-161	3	1165
DT-162R, DT-163A	3	1166
DT-190D	3	1166
DT-1020, DT-1020A	3	1165
DT-1030, DT-1030A	3	1165
DT-X-160	3	1165
E-520	3	1167
E-522	4	1555
E-170	3	1166
ET-140R, ET-141R, ET-171, ET-172	3	1166
ET-190D	3	1166
F-405	4	1556
F-523	4	1555
H-300	1897	
511	3	1168

**DUMONT**

RA-103D,		
RA-104A	3	1169
RA-109-A3	3	1170
RA-109-A7	3	1170
RA-110A	3	1169
RA-112-A1, -A2, -A3, -A4, -A5, -A6 (below serial No. 126293)	4	1557
RA-112-A1, -A2, -A3, -A4, -A5, -A6 (above serial No. 126293)	4	1558
RA-113-B1, -B2, -B3, -B4, -B5, -B6, -B7, -B8 (below serial No. 135323)	4	1557
RA-113-E1, -E2, -B3, -B4, -B5, -B6, -B7, -B8 (above serial No. 135323)	4	1558
RA-119A	4	1559

Name & Model or Chassis No.	Vol. 5 Diag. No.	Previous Vols. Vol. No. Diag. No.	Name & Model or Chassis No.	Vol. 5 Diag. No.	Previous Vols. Vol. No. Diag. No.	Name & Model or Chassis No.	Vol. 5 Diag. No.	Previous Vols. Vol. No. Diag. No.
<b>DUMONT (Continued)</b>			<b>EMERSON (Continued)</b>			<b>EMERSON (Continued)</b>		
RA-166, RA-167, RA-168, RA-169, RA-170, RA-171	4	1560	518	1	158	<b>Chassis</b>		
RA-302		1898	519	2	555	120000	1	11
RA-307		1899	520	1	11	120002	1	158
RA-322		1900	522, 523	1	158	120003	1	160
Sherbrooke (RA-109-A3, A7)	3	1170	524	1	170	120006	1	162
Sherbrooke (RA-109A-FAS)	3	1170	525	1	159	120007	2	693
Sherbrooke (RA-130A)	3	1170	528	2	694	120012-B	2	701
<b>DYNAVOX</b>			530	2	695	120016	2	697
3-P-801	2	689	531, 532, 533	1	162	120025-B	3	1174
<b>ECA</b>			534	1	693	120029	1	11
101, 102	1	19	535	1	159	120030	2	585
104	1	18	536, 536A	2	696	120033	2	696
105	1	151	537	2	694	120038	2	694
106	1	18	539	1	159	120039-B	2	701
108	1	18	540A	1	165	120041	1	158
131	1	154	541	1	73	120042	1	185
132	2	690	543, 544	1	159	120043	2	694
201	1	152	546	2	695	120046	1	159
204	2	574	547A	2	697	120048-P	2	698
<b>ECHOPHONE</b>			550 (Ch. 120056)	2	693	120049	2	695
EC112	1	153	551A	2	696	120050	2	697
EC113	1	153	552	1	159	120056	2	693
EC306	1	157	553	2	696	120058	2	699
EC403, EC404	2	677	557B	2	698	120059	2	697
EC600	1	147	558	2	699	120069-A	2	702
EX306	1	157	559A, 560	2	697	120072-A	2	703
<b>EDWARDS</b>			563	3	1171	120089-A	2	703
Fidelotuner	2	691	567 (Ch. 120042)	2	185	120098-B	3	1174
<b>ELCAR</b>			568A	2	700	120098-B, -D	3	1174
602	1	155	570	3	1172	120098-P	3	1178
<b>ELECTRO</b>			573B	2	701	120098-P	3	1178
B20	1	163	574	3	1172	120099-B	3	1178
<b>ELECTROMATIC</b>			575	3	1173	120130-P	4	1563
606A, 607A	1	156	576A	2	702	120132-B	3	1187
<b>ELECTRONIC LABS.</b>			577B	2	702	120134B, -G, -H	4	1562
76E, 76K	1	167	578	2	697	120136-B	4	1561
76RU	1	161	583	2	701	120150-B	4	1566
76W	1	187	584	2	699	120151-B	4	1567
710B, 710M	1	187	585, 586	3	1174	120174-B	1903	
710PB, 710PC	2	692	587	3	1175	120175-B	1901	
710T, 710W	1	167	588	2	697	120176-B		
2701	1	167	597	3	1176	120177-B	1902	
<b>ELECTRO-TONE</b>			602	2	703	120180-D	1904	
555	1	18	604A	2	702	120189-B	1906	
706	1	18	613A	3	1177	120193-B, -F	1903	
712	1	18	621 (Ch. 120098-B)	3	1178	120195-D	1904	
<b>EMERSON</b>			622 (Ch. 120098-P)	3	1178	120197-B, -D	1903	
DS365, DS372	1	164	628	3	1178	120198-D	1904	
EQ368, EQ410	1	166	630	3	1178	120199-P	1905	
ER369, ER370	1	166	634B	3	1179	120209-D, -F	1903	
EY384	1	166	635	3	1180	120211-D, -F	1904	
FH413	1	162	636A	3	1175	120221-A	1907	
FH440	1	162	640	3	1181	120222-B	1908	
FJ412	1	160	641B	3	1182	<b>EMPRESS</b>		
FW423	1	160	642 (Ch. 120117-A)	3	1183	55, 56	1	174
GB439, GB441	1	162	643A	3	1184	<b>ESPEY</b>		
GH437, GH447, GH2-447	1	160	645	3	1185	RR13, RR13L	1	168
501, 502, 503, 504	1	11	646A, 646B	3	1186	7B	2	567
505 (Ch. 120002 & 120041)	1	158	652 (Ch. 120032-B)	3	1187	7C	4	1568
506	1	160	653 (Ch. 120080-B)	3	1188	18R	3	1193
507, 509, 510, 511	1	158	658B	4	1561	31	3	1194
511 (Ch. 120010)	1	73	656, 657B	3	1189	100, 101	1908	
512 (Ch. 120006)	1	162	661B	4	1562	201	1910	
512 (Ch. 120056)	2	693	665B (Radio Ch.)	4	1563	300, 301	1911	
514	2	693	666B (Ch. 120132-B)	3	1190	400, 500	1957	
515 (Ch. 120056)	2	693	667B, 668B	4	1562	511C, 512B	4	1568
515	1	162	671B	3	1191	524	3	1193
516 (Ch. 120056)	2	693	672B	3	1192	581	1	73
516	1	162	674B	4	1562	651, 652, 653	1	15
<b>EMERSON (Continued)</b>			677B, 678B	4	1562	700	1909	
			679B	4	1563	710	1911	
			684B, 685B	4	1562	751	3	1193
			691B	4	1561	8511, -2, -S, 6514, 6516, 6517, 6520, 2, 6521, 6533, 6540, 6541, 6542, 6545, 6546, 6547, 6560	1	15
			695B	4	1564	6611, 6612, 6613, 6614, 6615, -S	1	15
			703B (Ch. 120097-B)	4	1565	6630, 6631, 6632, 6634, 6635	1	172
			718B	4	1566	7541	1	15
			724B	4	1567	<b>FADA</b>		
			744B	1901		H-274T,		
			745B, 746B	1902		H-276T	1912	
			752A, B,			H-442C,		
			755A, B	1903		H-542C	1912	
			759C, 761C	1904		P100	2	704
			770C, 772A,			P130	3	1195
			774A	1903				
			778B	1905				
			784A, E, G, K	1903				
			783C, E, K	1904				
			799E, 794A,	1903				
			808B	1906				
			809A	1907				
			810B	1908				
			1001G,					
			1002, 1003,	1	169			
			1003G					
			1013C					

Name & Model or Chassis No.	Vol. 5 Diag. No.	Previous Vols. Vol. No. Diag. No.
<b>FADA (Continued)</b>		
S4C20, S4C40, S4T1S, S4T30	4	1569
S8C5S, S8C70, S8T6S	3	1196
S7C20, S7C30, S7C70, S7T6S	3	1196
S9C10	3	1196
S20T20	3	1196
S1060, S1065, UDL2100T, UH21T	1913	
U1700CD, U1770CD	1914	
U2100C, T, U2150C	1913	
602	1	178
605, 606	1	185
609, 610	1	73
637	1	175
652	1	171
700	2	705
711	2	574
740	2	574
795	2	706
830	3	1197
845	3	1198
855	3	1199
1000 series	1	173
1001	1	175

### FARNSWORTH

BC66	1	176
BC103, BC105	1	177
BC601, BC601X	1	186
BK106, FK107, BK108	1	177
BK110, BK111, BK112	1	188
BK602	1	186
BK602S, BK6025X	1	186
BT20	1	73
BT22	1	176
BT52, BT53, BT54	1	73
BT55, BT56, BT61, BT63	1	176
BT600, BT600X	1	186
CK70	1	187
CK58, CK66, CK73, CK74, CK75	1	179
CK111	1	187
CT50, CT51, CT52, CT53, CT54	1	179
CT61, CT62, CT63, CT64	1	179
DK73, DK75	1	187
EC260	1	28
EK-081, EK-082, EK-083	2	707
EK-262, EK-263, EK-263BL, EK-263WL, EK-264, EK-264BL, EK-264WL, EK-265	1	28
EK-581	2	707
ET-060, ET-061, ET-062, ET-063, ET-064, ET-065, ET-066	1	180
GK-100, GK-102, GK-103, GK-104, GK-111, GK-112, GK-114, GK-115, GK-140, GK-141, GK-142, GK-143, GK-144	2	708
GT-060, GT-061, GT-064, GT-065	2	709

### Chassis

150	1	180
152, 153	1	28
156, 157	2	707
158, 159	1	180
162	1	28
170	2	707
193, 194	2	707
201	2	707
216	2	707

### FEDERAL

1030T	1	138
1040T, 1040TB	2	710
1540T	1	138

### FERRAR

C81-B	1	184
T61-B	2	711

### FIRESTONE

4-A-2	1	21
4-A-3	2	560
4-A-10	2	712
4-A-11	2	713
4-A-12	2	714
4-A-15	2	715
4-A-17	2	716
4-A-20	1	20
4-A-21	1	22
4-A-21X	1	24
4-A-22	1	22
4-A-22X	1	24
4-A-23	1	25
4-A-24	1	23
4-A-25	1	26
4-A-26	2	717
4-A-27	2	718
4-A-31	1	28
4-A-37	1	27
4-A-41	2	719
4-A-42	2	644
4-A-60	2	720
4-A-61	2	721
4-A-66	3	1200
4-A-71	2	722
4-A-78, 4-A-79	3	1201
4-A-85	3	1202
4-A-86	3	1203
4-A-86 (late)	4	1570
4-A-87	3	1204
4-A-108	4	1571
4-A-110	4	1520
4-A-113, 4-A-114	1915	
4-A-115	1916	
4-A-127, 4-A-128	1917	
4-A-133	1918	
4-B-1, 4-B-2	1	29
4-B-56	3	1133
4-B-57	3	1075
4-B-58	3	1132
4-B-60	4	1522
4-B-61	4	1519
4-B-62, 4-B-67	4	1522
4-B-69	1858	
4-B-71	1856	
4-B-72	1919	
4-B-74	1920	
4-C-3, 4-C-6	1	36
4-C-16, 4-C-17	3	1205
4-C-18	3	1206
4-C-21	4	1517
4-C-24	1921	
13-G-3	3	1207
13-G-4	3	1208
13-G-33	3	1209
13-G-48	4	1572
13-G-57	4	1573
13-G-128, 13-G-129, 13-G-130, 13-G-132	1834	
13-G-145, 13-G-146	1834	
S7400-4, -5, -7	1	33

### FISHER

FM-80	1922
50R, 50RT	1923
70RT	1924

### FLUSH WALL

5P (Early)	2	614
5P (Late)	1925	

### FORD

7070 (51A-18805-B2)	2	723
5BF (FDH-18805-B1)	1926	
5MF (FDH-18805-B2)	1927	
5MF8 (FDH-18805-A2)	1	181
6MP080	1	181

### FREED EISEMANN

46	1	193
717, 750	1928	

### GAMBLE SKOGMO (Also See Coronado)

C4B15, C4B16	1	48
C5D14	1	40
C5D16	1	48
15C6A	1	191
15C6B	1	190
864	1	80
3128 (Late)	1	182
4132	1	182
4164	1	183
4956	1	45

### GAROD

5A-1	2	724
5A-2	1	192
5A-3	2	725
5A-4	2	726
SAP1-Y	1	189
5D, 5D-2	1	194
5D-3, 5D-3A	2	727
5D-4, 5D-5	2	728
5RC-1	2	726
6A-2	2	724
6AU-1	1	82
6BU-1A	1	195
6DPS, 6DPS-A	1	196
10T2, 10T21, 10T22, 10T23, 10T24, 10T25	2	729
11FMP	2	730
12T2, 12T21, 12T22, 12T23, 12T24, 12T25, 12T26A, 12T27A	2	729
15T2, 15T26, 15T27	2	729
6B2B	2	661
306	2	731
900TV, 910TV, 1000TV, 1001TV, 1100TV, 1110TV, 1200TV, 1210TV	2	732

### GENERAL ELECTRIC

G61	1	197
G64, G65	1	200
G66, G68, G69	1	197
G75	1	200
G78	1	197
G85	1	198
G86	1	197
G95	1	202
G99	1	198
GDE-73	1	204
GE-52	1	206
GE-73, GE-78	1	204
GE-93, GE-96	1	205
H73, H77, H78, H79, H87	1	203
H116, H118	1	203
H600, H600U, H601	1	207
H610, H610U, H611	1	207
H620, H620U, H621, H622, H623, H625	1	206
H630, H630U, H631, H632, H632U, H633	1	208
H634	1	203
H638, H640	1	203
H708	1	209
H736	1	209
HE74, HE74L, HE100, HE100H, HE100L, HE100LH	1	199
HE105, HE105L	1	199
HE740, HE740L	1	204
HJ119	1	203
HJ737	1	209
HJ905, HJ908, HJ908B	1	203
HJ1005	1	203
HJ1205	1	203
J62, J63	1	210
J64	1	211
J71	1	211
J105	1	212
J602, J603	1	211
J614	1	212

Name of Model or Chassis No.		Vol. No.	Diag. No.	Previous Pages	Name of Model or Chassis No.		Vol. No.	Diag. No.	Previous Pages	Name of Model or Chassis No.		Vol. No.	Diag. No.	Previous Pages	
<b>GENERAL ELECTRIC (Continued)</b>					<b>GENERAL ELECTRIC (Continued)</b>					<b>GENERAL TELEVISION (Continued)</b>					
J620		1		210	118		2		735	9A5		2		574	
J664		1		212	119M, 119W		2		735	14A4 F		1		6	
J709		1		209	123, 124		3		1212	15A5, 17A5,					
J718, J728		1		211	131		2		735	19A5, 21A4,					
J805, J808, J809,					135, 136		3		1213	22A5C, 23A6		1		73	
J818, J828		1		211	143		3		1214	4B5		2		574	
J1105, J1108		1		211	145		2		736	5B5G, 5B5Y		2		745	
JES1		1		213	150		2		737	9P6P		2		574	
JE101, JE107		1		215	160		2		738	24B6, 25B5		2		574	
JE810		1		213	185		3		1215						
L600, L601, L610					180		1		219						
L611		1		212	200, 201, 203,					<b>GILFILLAN</b>					
L631, L642, L643		1		212	205, 205M		1		222	56A, 56B, 56BC-1,					
L650, L651, L652		1		214	210, 211, 212		2		739	56BCR, 56C,					
L653		1		212	218, 218" H"		3		1216	56D, 56E		1		73	
L660		1		214	219, 220, 221		1		227	58M, 58W		2		555	
L663, L673, L674		1		212	226		3		1217	66A, 66AM		1		229	
LF115, LF116		1		216	250		1		225	66B		1		73	
LFC1118, LFC1128,					254		2		740	66D, 66DM		1		229	
LFC1228		1		216	260		1		225	66P, 66PM		1		231	
X115, X125, X145		1		220	280		2		678	68BD		2		746	
X225A, X225V		1		212	303		1		223	68 F		2		747	
10C101, 10C102,					304		2		741	86C, 86P, 86U		2		748	
10T1, 10T4, 10T5,					321		1		224	108-48		2		749	
10T6		3		1210	326, 327		1		226						
12C101, 12C102,					354, 355		2		742	<b>GLOBE</b>					
12C105		3		1210	356, 357, 358		2		743	5BP1		1		233	
12C107, 12C107B,					376, 377, 378		2		744	6AP1		1		228	
12C108, 12C108B,					400, 401		3		1218	6D1		1		232	
12C109, 12C109E		3		1211	404, 405		3		1219	6P1		1		228	
12T1		3		1210	408		3		1220	6U1		1		232	
12T3, 12T3B,					409		4		1575	7CP1		2		614	
12T4, 12T4B		3		1211	410		3		1219	82C		1		237	
14C102, 14C103		3		1211	411		3		1218	45C		2		750	
14T2, 14T3		3		1211	412		4		1576	45F		2		590	
16C103		3		1211	412 F		4		1577	500		2		751	
16C110, 16C111		3		1211	414		4		1576	517		2		752	
16C113		3		1211	414 F		4		1576	45T		2		751	
16C115, 16C116,					415		4		1577	500		2		752	
16C117		3		1211	415 F		4		1577	511		1		11	
16T1, 16T2, 16T3,					416		4		1576	552		2		753	
16T4, 16T5		3		1211	416 F		4		1577	553		2		614	
17C101, 17C102		3		1211	417		1		230	<b>GON-SET</b>					
17C103, 17C104,					422, 423		4		1578	10-11 (Meter Con- verter)		2		689	
17C105, 17C107,					427, 428,					<b>GOODRICH (Also See Mantola)</b>					
17C108, 17C109,					429			1933	92-523, 92-524,						
17C112, 17C114		4		1574	430		4		1576	92-525, 92-526,					
17T1, 17T2, 17T3,					431, 432			1934	92-527, 92-528		4			1588	
17T4, 17T5, 17T6,					440			1935	<b>GRANCO</b>						
17T7		4		1574	442, 443,				LCU			1944			
17T20			1929,		444			1933	MTU			1945			
			1930		446, 447,				610			1946			
20		1		210	448			1936	<b>GRANTLINE</b>						
21C40			1931		502		2		733	500, 501		1		234	
21C103,					535		4		1579	501-7		2		754	
21C104			1929,		546, 547, 548,				508-7		2		755		
			1930		549		4		1580	510-A		2		756	
21C130,					551, 552		4		1581	605, 606 (Series A)		1		92	
21C131			1931		564, 565, 566		4		1937	651		1		15	
21C151,					572, 573,				5610		2		757		
21C152,					574, 575			1938	6547		1		15		
21C156,					577, 578			1939	<b>HALLICRAFTERS</b>						
21C157			1931		580, 581, 582			1940	CA-2, CA-2A, CA-4		2		758		
21C240,					590			1941	S-38		1		235		
21C241 (Early)			1929,		601, 603, 604		3		1221	S-38B		3		1230	
			1930		605, 606, 607, 608		4		1582	S-38C (Run 2)		4		1589	
21C240,					610, 611		4		1583	S-40		1		236	
21C241 (Late)			1929,		612, 613			1942	S-40A		2		759		
			1932		614		4		1584	S-40B		3		1231	
21C347,					630, 631, 632			1943	S-41B, S-41G,						
21C348,					650		3		1223	S-41W		1		242	
21C349,					741		4		1585	S-47		2		677	
21C350,					752, 753		3		1224	S-51		2		555	
21C351			1930		754		4		1586	S-52		2		759	
21T22,					755		3		1225	S-53		2		760	
21T23,					757		3		1225	S-53A, AU		4		1590	
21T24,					800A, B, C, D		3		1226	S-55, S-56		2		761	
21T25			1929,		805, 806,				S-58, S-59		2		762		
			1930		807, 809		3		1226	S-72		3		1592	
21T26,					810		4		1587	S-73		4		1591	
21T27 (Early)			1929,		811		3		1227	S-76, S-76U		4		1592	
			1930		A&E				S-77		4		1593		
21T26,					814 (Fine Tuning)		3		1227	S-78		3		1233	
21T27 (Late)			1929,		A				S-78A		4		1594		
			1932		814 (Focus Control)		3		1228						
21T30,					817		3		1226						
21T31			1930		821		3		1226						
35		1		215	830, 835, 840		3		1229						
40		1		216	<b>GENERAL IMPLEMENT</b>										
41, 42, 43, 44, 45		2		733	9A5		2		574						
50		1		218	<b>GENERAL TELEVISION</b>										
100, 101		1		217	1A5, 2A5, and Radio History		1		73						
102, 102W		2		734											
103, 105		1		217											
106		1		221											
107, 107W		2		734											
114, 114W, 115,															
115W		2		734											

Name & Model or Chassis No.	Vol. 5 Diag. No.	Previous Vols. Vol. No.	Diag. No.
--------------------------------	------------------------	-------------------------------	--------------

**HALLICRAFTERS (Continued)**

S-80	4	1595	
S-81, S-82	4	1596	
ST-74	3	1234	
ST-83	1947		
SX-42	2	763	
SX-43	2	764	
SX-71	3	1235	
TW-500			
TW-600	1948		
TW-1000	1949		
TW-2000	1950		
5R10	3	1236	
5R10A	4	1597	
5R30, A, 5R31 A,			
5R32, A, 5R33, A,			
5R34, A	4	1598	
5R50, 5R51, 5R52	4	1598	
5R60, 5R61	1951		
8R40, 8R40C	4	1599	
400, 406, 409,			
410, 411, 412	2	677	
611, 612	1952		
621, 622	1952		
680, 681	3	1237	
690	3	1237	
715, A, 716	3	1237	
730, 731	3	1237	
740, 741	3	1237	
810A, 811, 815,			
818, 820, 822	3	1238	
860, 861	3	1238	
870, 871	3	1238	
880	3	1238	
1005, 1006, 1015,			
1016, 1017, 1018,			
1019	4	1600	
1025	4	1601	
1621, 1622	1953		
17811-H, 17816,			
17817, 17824-A,			
17906, 17930,			
17931, 17932,			
17933, 17934	4	1602	
20923C	4	1602	
20990, 20990S,			
20994	4	1601	
21923, 21928,			
21940, 21980	4	1602	
Chassis			
A1100D	4	1600	
Z1000D	4	1600	

**HARVEY-WELLS**

ATR-3-6	2	765	
ATR-3-12	2	765	

**HOFFMAN**

A-200	1	239	
A-202	1	240	
A-300	1	82	
A-309	1	240	
A-401	1	82	
A-501	1	241	
A-700	1	238	
B-400	1	244	
B-1000	1	18	
C-501	2	766	
C-502	2	767	
C-503	2	766	
C-504	2	767	
C-306, C-507	2	768	
C-511	2	766	
C-512	2	767	
C-513	2	766	
C-514	2	767	
C1006, C1007	2	767	
C1006, C1007	2	767	
21B907,			
21M906,			
21P908	1954		
Chassis			
102	1	82	
103	1	239	
108ST	1	241	
110S	1	238	
114	1	240	
119	1	18	
123	2	767	

**HOWARD**

4PT	1	171	
220, 221	1	171	

Name & Model or Chassis No.	Vol. 5 Diag. No.	Previous Vols. Vol. No.	Diag. No.
--------------------------------	------------------------	-------------------------------	--------------

**HOWARD (Continued)**

270, 271	1	171	
300 Series	1	243	
307-4, 307TP-2	1	243	
430(Series 2)	1	246	
438	1	246	
460	1	250	
472AC, 472AF,			
472C	2	769	
472F	2	770	
474	2	555	
482, 482A	2	761	
500 Series	1	245	
718FM	1	249	
765, 768, 780,			
808, 808	1	248	
808 (Series X)	1	257	
810	1	259	
810	1	247	
865, 868	1	255	
901A-E, -H, -L,			
-M, -P, -W	1	73	
906, 906C	1	253	
909M	2	771	
920	1	73	

**HUDSON**

DE39	1	256	
DB40	1	252	
SA39	1	256	
SA40	1	252	

**JACKSON**

150, 153	3	1239	
254	4	1603	
255	4	1604	
350	3	1240	

**JEFFERSON TRAVIS**

MR-2B, MR-3	1	251	
-------------	---	-----	--

**JEWEL**

500A, B, C, 501A,			
B, C, 502A, B, C,			
503A, B, C, 504A,			
B, C, 505A, B, C	1	18	
960, 960U, 961	3	1241	
5020, 5020U	3	1242	
5057U	3	1243	

**KAPPLER**

102T	2	772	
------	---	-----	--

**KARADIO**

M80B	1955		
1276	3	1244	

**KNIGHT**

D-182	1	249	
D-197	1	249	
SX8L727	1909		
SX11L719	1911		
SX14L721	1956		
SX19L720	1957		
4D-450	2	633	
4G-420	3	1245	
5A-150, 5A-152,			
5A-154	1	15	
5A-190	1	11	
5B-160	1	18	
5B-175, 5B-176	1	16	
5B-185	2	773	
5C-290	2	573	
5D-250, 5D-251	2	570	
5D-455	2	572	
5F-565	2	574	
5J705	4	1605	
5K715	4	1606	
6A-122	1	254	
6A-127	1	261	
6A-195	1	254	
6B-122	1	254	
6B-127	1	261	
6C-225	2	578	
6D-225, 6D-226	2	578	
6D-235	2	745	
6D-360	2	649	
6G-400	3	1249	
6H-580	3	1246	
6K718	1958		
7P-220	2	754	
7D-405	2	774	

Name & Model or Chassis No.	Vol. 5 Diag. No.	Previous Vols. Vol. No.	Diag. No.
--------------------------------	------------------------	-------------------------------	--------------

**KNIGHT (Continued)**

8B-210	1	258	
8D-340	2	645	
8G-200, 8G-201	3	1247	
10E-249	2	775	
11C-300	2	645	
11D-302	2	567	
12H610	4	1607	
19F-492, 19F-497,			
19F-498	2	776	
20H611	4	1607	
93-326	4	1608	
94S445	1959		
94SX728	1960		
97-870	3	1248	
200	1957		
449	3	1249	
511B	3	1250	
722	1909		

**LAFAYETTE**

B33	1	6	
E112	1	41	
E195	1	183	
BB9 (A)	1	191	
BB9 (B)	1	190	
FA15W, FA15Y	1	257	
J62, J62C	1	237	
MC10B, MC10Y	1	11	
MC11, MC12	2	777	
MC13	1	11	

**LEARADIO**

R971	2	778	
RM402C	2	779	
561, 562, 563	1	260	
565, 565BL, 566,			
567, 568	1	260	
681	1	270	
1281PC	2	761	
6610PC, 6611PC,			
6612PC	1	270	
6614, 6615, 6616			
6617PC, 6619	1	260	

**LEWYTT**

615A	1	265	
711	2	560	

**LEXINGTON**

6545	1	15	
------	---	----	--

**LIBERTY**

A6K, A6P	1	264	
6K	1	264	
507A	1	264	

**LINCOLN**

S13L-N	1	185	
--------	---	-----	--

**LINCOLN (Allied Radio Corp.)**

5A-110	1	26	
--------	---	----	--

**LYRIC**

546T, 546TY,			
546TW	1	73	

**MAGIC TONE**

500, 501	1	19	
----------	---	----	--

**MAGNAVOX**

Chassis			
CMU-422AA	1961		
CMUA-435AA,			
CMUA-436AA	1961		
CMUA-455AA,			
CMUA-456AA	1961		
CR-101, CR-101M	1	262	
CR-108M	1	266	
CR-122	1	266	
CR-187, CR-188	1	263	
CR-189A, CR-189B	1	267	
CR-190	1	271	
CR-190A, CR-190B	2	780	
CR-192A, CR-192B	1	267	
CR-193	1	263	
CR-197C	2	781	
CR-198A, CR-198B,			
CR-198C	1	263	

Name & Model or Chassis No.	Previous Vol.		Name & Model or Chassis No.	Vol. 5	
	Diag. No.	Vol. No.		Diag. No.	Vol. No.
<b>MAGNAVOX (Continued)</b>					
CR-200A, B, C, D, E, F					
CR-207A, B, C, D	2	782			
CR-330A-1	2	783			
CR-700	1963				
CR-702A, B (260M Series)	1964				

<b>MAGUIRE</b>					
500BI, 500BW, 500DI, 500DW	1	269			
561BI, 561BW, 561DI, 561DW	1	269			
571	2	784			
661, 661A	1	269			
700A, 700E	1	268			

<b>MAJESTIC</b>					
4PI	1965				
5A410, 5A430	1	272			
5A445, 5A445R	2	614			
5AK711, 5AK731, 5AK780	2	785			
5C-2, 5C-3	4	1609			
5LA5, 5LA6	3	1251			
5LA7, 5LA8	3	1252			
6FM714	2	786			
6FM773	2	787			
7C432, 7C447	1	274			
7FM877, 7FM888	2	787			
7JK777R	2	788			
7JL866	2	788			
7P420	2	789			
7S433, 7S450, 7S470	2	790			
7YR752	2	791			
7YR753, 7YR772	2	789			
8FM744, 8FM775, 8FM778, 8FM889	2	792			
8JL885	2	793			
8S452, 8S473	1	273			
12FM475, 12FM778, 12FM779, 12FM895	2	794			
20FP86, 20PP89 (Radio Ch.)	4	1610			
21P52, 21P83 (Series 110, 111)	1966				
80FMP2	4	1610			

<b>MAGUIRE</b>					
5B01A, 5B05A	2	785			
6B02D	2	786			
6B11D	2	787			
7B04A	2	791			
7B09A, 7B09A1	2	789			
7C11D	2	787			
7C25A	2	788			
8B06D, 8R07D, 8B08D, 8C07D	2	792			
12B20E, 12C22E	2	794			
4501, 4504	1	272			
4506	2	614			
4702, 4703	2	790			
4705	2	789			
4706, 4707	1	274			
4708R	2	788			
4810	1	273			
4810E	2	793			
4120T	2	794			

<b>MALLORY</b>					
TV-101	4	1535			

<b>MANTOLA</b>					
R459	1	118			
R643	1	4			
R652, R652N	1	6			
R655W - PM, -PV	1	275			
R655W	1	6			
R662, R662N	1	6			
R664PM, PV, W	2	795			
R7543	1	73			
R75143	2	574			
R75152	2	796			
R75343	2	574			
R76143	2	574			
R76162	2	796			
R76262	2	797			
R76162	2	798			
24B8	2	574			
92-529	4	1611			

Name & Model or Chassis No.	Previous Vol.		Name & Model or Chassis No.	Vol. 5	
	Diag. No.	Vol. No.		Diag. No.	Vol. No.
<b>MASCO</b>					
RK-5SLR			4	1612	
<b>MASON</b>					
45-1A, 45-1B, 45-1P			1	73	
45-3, 45-4, 45-5			1	73	

<b>MATTISON</b>					
630DXM, 630MDXL				1967	

<b>MAYFAIR</b>					
510, 510W	2	799			
520, 520W	2	799			
530, 530W	2	799			
550, 550W	2	799			

<b>MECK</b>					
CD-500, CE-500	2	800			
CR-500	2	801			
EF-730, EF-731	3	1253			
MM510T, MM512T, MM516C, MM516T	3	1254			
PM-5C5-DW10			1	6	
PM-5C5-PW10			1	6	
RC-5C5-P	1	6			
RC-6A7-P6	2	802			
XOB, XQA, XQR, XRA, XRPT, XSA, XSPT, XTA, XTR, XX900	3	1254			
4C7	2	803			
6A6-W4	1	187			
9030	1968				

**MEDCO (See Teleonic)**

<b>MEISSNER</b>					
4E	4	1613			
8BT	4	1614			
8C	2	804			
9AJ	3	1255			
9-1065	1	6			
9-1091A, 9-1091B	2	805			
9-1091C	3	1256			
9-1093	2	806			
16A	1	1257			
2961 Series	3	807			

<b>MERCURY (Pacific Mercury)</b>					
2081, 2181 (Radio Ch.)	4	1615			
2217, 2218, X, 2224, 2284	4	1616			
2701	1993				

<b>Chassis</b>					
155	4	1615			
200-11	4	1616			

<b>MIDLAND</b>					
M6B	1	278			

<b>MIDWEST</b>					
KD-16	1969				
P6, PB6	1	276			
R12, RG12, RT12	2	808			
R16, RG16	2	808			
RN-16	1969				
RT-16	2	808			
SS, ST8	1	282			
SI2, SG12, ST12	2	809			
SI6, SG16, ST16	2	809			
TM8	1	282			

<b>MINERVA</b>					
L-702	1	171			
L-728	1	19			
W-117	1	6			
W-117-3	1	11			
W-702-B	1	171			
W710, W710A	1	281			
W-728	1	19			
410, 411	2	810			
702H, 702M	2	810			
729	2	704			

Name & Model or Chassis No.	Previous Vol.		Name & Model or Chassis No.	Vol. 5	
	Diag. No.	Vol. No.		Diag. No.	Vol. No.
<b>MITCHELL</b>					
1254			4	1617	
1278		1970			
1287		1971			

<b>MONITOR</b>					
M510		2		811	
M5070		2		812	
RA50		2		813	
TA56M, TW56M		1		129	

<b>MONITORADIO</b>					
AR-1, AR-3			4	1618	
DR-200		1972			
M-51A			4	1619	
M-101			4	1618	
MR-32		1973			

**MONTGOMERY WARD (See Airline)**

<b>MOPAR</b>					
600, 601, 602			1	112	
802			1	111	
802 Revised			1	111	
805			3	1258	
808, 809			3	1259	
814			4	1620	
819			4	1621	
829		1974			
830		1975			

<b>MOTOROLA</b>					
EK2V		4		1622	
PK-6		1		279	
CR-6		1		280	
CR-78		2		815	
CTM3				1976	
CT1M		4		1623	
CT2M		4		1622	
CT-6		1		279	
CT52M6				1977	
FD-6, FD-7			1	279	
GMT2M, HJ2M, HN2M			4	1624	
HN4M6				1977	
HN53M6				1977	
KR2M		4		1624	
NH6		1		279	
OE2M		4		1624	
OE6		1		279	
PC2M		4		1624	
PC6		1		279	
PD2M		4		1624	
SR0B		3		1260	
SR1B		3		1282	
SR2M (Early)		4		1625	
SR2M (Late)		4		1624	
SR52M6				1977	
VF102, VF102A, VF102C			2	814	
VF103, VF103M			3	1261	
VK101, VK101M			2	814	
VT101		2		814	
Y21F5, B (Radio Ch.)				1977	

<b>(Radio Ch.)</b>					
5C1, 5C2, 5C3, 5C4, 5C5, 5C6			3	1262	
5H1U, 5H12U, 5H13U			3	1263	
5X11U, 5X12U, 5X13U			3	1264	
5X21U, 5X22U, 5X23U			3	1265	
6F11, 6F11B			3	1266	
6L1, 6L2			3	1267	
6X11U, 6X12U			3	1268	
7F11, 7F11B			3	1269	
8FM21, 8FM21B, 9FM21, 9FM21P			3	1271	
9-24, 9-24A			1	285	
9-44			1	288	
16-C			1	284	
16F1, RH, H			3	1280	
17-D			1	287	
17F1, A, B, BA, 17F2W, WA, 17F3B, EA, 17F4, A, 17F5, A, B, BA			3	1281	
17F11 (Radio Ch.)			4	1626	
17F12, A, B, BA			4	1626	
17F13, E					
17F13PC					
17F13C			4	1626	

Name & Model or Chassis No.	Vol. 5 Diag. No.	Previous Vols. Vol. No. Diag. No.
<b>MOTOROLA (Continued)</b>		
18-O, 19-B	1	289
21F1, P	4	1627
21F5, B		
(Radio Ch.)	1978	
25-F	1	290
26-C, 26-C7	1	291
27-D, 27-D6	1	293
28-O, 29-B, 29-B6	1	291
30-P	1	291
35-F	1	294
35-N	1	292
36-C1, 36-C2	1	295
37-D1, 37-D2	1	296
38-O	1	291
39-B1, 39B2	1	291
40-P	1	286
43-H	1	297
44-K	1	298
45-B12	1	158
45-N	1	299
47P11	2	816
51-A, 51-C	1	73
51F11	1	300
51F12	1	301
51R11	1	300
52-C	1	73
52C1, 52C1A,		
52C6	4	1628
52H11U, 52H12U,		
52H13U, 52H14U	4	1629
53-A, -C	1	73
53H1, 53H2,		
53H3, 53H4	1978	
53LCL1,		
53LCL2,		
53LCL3	1980	
53X1, 53X2		
53X3, 53X4	1981	
54-A, -C	1	73
55F11	1	303
55X11	1	302
55X11A	1	304
55X12	1	302
55X12A	1	304
55X13	1	302
55X13A	1	304
56X11	2	669
57X11, 57X12	2	817
58A11, 58A12	2	869
58X11, 58X12	2	818
59H11U, 59H12U	3	1272
59X11, 59X121	3	1273
59X21U,		
59X22U	3	1274
60-KW	1	301
61-A, 61-B	1	305
61-C, 61-D	1	308
61-E	1	305
61-F	1	307
61T21	1	308
61T23	1	314
61X11, 61X12,		
61X13	1	301
62-A, 62-B	1	305
62C1, 62C1A,		
62C2, 62C2A,		
62C3, 62C3A	4	1630
62CW1	4	1631
62-E	1	305
62-F1	1	312
62L1U, 62L2U,		
62L3U	4	1632
62X11U, 62X12U,		
62X13U	4	1633
62X21	1982	
63-A, 63-E	1	305
63LSS	1983	
63L1, 63L2,		
63L3	1984	
63X1, A,		
63X2, 63X3	1985	
63X21	1986	
64X1, 64X2	1987	
65F11, 65F12	1	303
65F21	1	309
65T21, 65T21B	1	310
65X11, 65X11A,		
65X12, 65X12A,		
65X13, 65X13A,		
65X14, 65X14A,		
65X14P	1	19
67F12E, 67F12I,	2	819
67F14	2	820
67F16BN	2	821
67L11	2	822

Name & Model or Chassis No.	Vol. 5 Diag. No.	Previous Vols. Vol. No. Diag. No.
<b>MOTOROLA (Continued)</b>		
67X11, 67X12,		
67X13	2	820
67XM21	2	823
68F11, 68F12,		
68F14, 68F14B,		
68F14M	2	819
68T11, 68X11,		
68X11A, 68X12,		
68X12A	2	825
69L11	3	1275
69X11, 69X121	3	1276
71-A	1	311
72-C	1	313
72XM21, 72XM22	4	1634
75F21	1	315
75F31, 75F31A,		
75F31B	2	826
76F31	2	826
77FM21, 77FM22,		
77FM22M,		
77FM23	2	823
77XM21, 77XM22,		
77XM22P	2	823
78F11, 78F11M,		
78FM12M,		
78FM21, 78FM21M,		
78FM22M	2	827
79XM21, 79XM22	3	1277
81-C	1	306
81F21, 81F22	1	308
81K31	1	316
82-A	1	317
83F1	1	312
83K1	1	321
85F21, 85K21	1	309
88FM21	2	827
93F1	1	312
95F31, 95F31B,		
95F33	1	320
99FM21R	3	1278
101F21, 101R21	1	319
103CK2	1	318
103F, 103F2	1	312
103K1	1	322
107F31, 107F31P	2	828
250, 251	1	325
395, 395-12	1988	
401A, 412	4	1635
<b>Chassis</b>		
AS-22	1	279
HS-2	1	19
HS-8	1	158
HS-26, HS-31	1	309
HS-30, HS-31	1	303
HS-32	1	310
HS-36, HS-36A	2	828
HS-38, HS-39	1	320
HS-50	1	304
HS-52	1	309
HS-58	2	820
HS-59	2	822
HS-60	2	817
HS-63	2	819
HS-64	2	823
HS-69	2	821
HS-72	2	816
HS-87	2	828
HS-89	2	823
HS-91	1	315
HS-94	2	669
HS-97	2	823
HS-98	2	826
HS-102	2	823
HS-108	2	814
HS-119	2	824
HS-122	2	820
HS-124	2	819
HS-125	2	818
HS-127, HS-127A	2	825
HS-128, HS-132,		
HS-133	2	827
HS-137	2	814
HS-144	2	825
HS-150, HS-155	2	827
HS-158	2	669
HS-168	3	1277
HS-170	3	1278
HS-175	3	1275
HS-180	3	1273
HS-181	3	1276
HS-192	3	1274
HS-210	3	1272
HS-226	3	1267
HS-228	3	1262
HS-230	3	1279

Name & Model or Chassis No.	Vol. 5 Diag. No.	Previous Vols. Vol. No. Diag. No.
<b>MOTOROLA (Continued)</b>		
HS-234	3	1280
HS-243	3	1264
HS-244	3	1263
HS-245	3	1268
HS-246	3	1271
HS-247	3	1270
HS-253	3	1281
HS-258	3	1262
HS-259	3	1265
HS-261	3	1281
HS-262	3	1262
HS-264	3	1266
HS-265	3	1269
HS-270, HS-271,		
HS-272	3	1262
HS-299	4	1630
HS-302	4	1626
HS-303	4	1634
HS-308	4	1632
HS-309, HS-310	4	1628
HS-313	4	1629
HS-314	4	1633
HS-316	4	1627
HS-319	4	1626
HS-324	4	1631
HS-326	1982	
HS-335	1985	
HS-336	1981	
HS-337	1979	
HS-347	1980	
HS-361	1984	
HS-385	1986	
HS-415	1983	
HS-440	1987	
CB		
QTS-502, Y	1978	
RM66	1977	
TS-3, TS-5, TS-7	2	814
TS-8	3	1261
1B	3	1282
<b>MURPHY</b>		
113, 122	1	258
<b>NATIONAL</b>		
Criterion	1989	
HRO-50	3	1283
HRO-50R1	4	1636
HRO-60	4	1637
NC-33	2	829
NC-46	1	326
NC-57	2	830
NC-98	1990	
NC-108R, NC-108T	2	831
NC-125	4	1638
NC-2-4DDR,		
NC-2-4DDT	2	832
SW-54	4	1639
<b>NATIONAL UNION</b>		
571, 571A, 571B	1	117
G-613	1	324
G-619	1	189
<b>OLDSMOBILE</b>		
982160	1	323
982282	1	327
982375	1	323
982543, 982579	4	1640
<b>OLYMPIC</b>		
HF500	1991	
6-501, 6-501VU,		
6-501WU	1	328
6-502, 6-602P,		
6-502U	1	328
6-503	1	328
6-504, 6-504L	1	6
6-601V, 6-601W,		
6-602	1	329
6-604 Series	2	833
6-606, 6-606A,		
6-606U	1	272
6-617, 6-617U	1	329
7-421V, 7-421W,		
7-431X	2	834
7-433V, 7-433W	2	834
7-526	3	704
7-532V, 7-532W	2	833
7-537	2	835
7-622, 7-638	2	774
7-724, 7-728	2	836

Name & Model  
or Chassis No. Vol. 5  
Diag.  
No. Previous Vols.  
Vol. No. Diag.  
No.

**OLYMPIC (Continued)**

7-925, 7-934, 7-936 ..... 2 ..... 837  
8-451 ..... 2 ..... 838  
8-533V, 8-533W ..... 2 ..... 839  
8-618 ..... 2 ..... 840  
8-925, 8-934, 8-936 ..... 2 ..... 841  
9-435V, W ..... 4 ..... 1641  
17K41, 17K42, 17K50 (Radio Ch.) ..... 4 ..... 1642  
20K43, 20K51, 21K61, 21K62, 21K63B ..... 4 ..... 1642  
51-421W ..... 4 ..... 1643  
489 ..... 4 ..... 1644  
505, B, 572B, M ..... 1992

**PACKARD-BELL**

5DA ..... 1 ..... 73  
5D8 ..... 2 ..... 574  
5FP ..... 1 ..... 73  
100 ..... 2 ..... 574  
551, 551-D ..... 1 ..... 333  
556 ..... 1 ..... 333  
561, 563 ..... 1 ..... 330  
566 ..... 1 ..... 333  
588 ..... 1 ..... 73  
571, 572 ..... 2 ..... 842  
651 ..... 1 ..... 333  
661 ..... 1 ..... 331  
662 ..... 1 ..... 332  
673A, 673B ..... 2 ..... 843  
682 ..... 2 ..... 844  
771 ..... 2 ..... 845  
861 ..... 1 ..... 332  
872 ..... 2 ..... 846  
880, 880A, 881A, 881B ..... 2 ..... 843  
884, 892 ..... 2 ..... 847  
1052 ..... 1 ..... 334  
1054B ..... 1 ..... 337  
1063 ..... 1 ..... 272  
1181, 1181A ..... 3 ..... 1285  
1273 ..... 2 ..... 848  
1472 ..... 2 ..... 849  
2301-TV (Radio Ch.) ..... 3 ..... 1286  
2302 (Radio Ch.) ..... 3 ..... 1286  
2311, 2811A (Radio Ch.) ..... 4 ..... 1645  
2801-TV ..... 3 ..... 1286  
2803TV ..... 3 ..... 1287

**PENTRON**

AFM ..... 1994

**PHILCO**

A-T228A ..... 4 ..... 1646  
A-UT2272 ..... 1005  
B570, B574 ..... 1996  
B652 ..... 1997  
B714, X ..... 1996  
B956 ..... 1998  
B1349, B1352 ..... 1999  
B1752, B1753 ..... 1999  
B1756 ..... 2000  
C667 ..... 2001  
C1348 ..... 1999  
C-4608 ..... 1 ..... 111  
C-4608 Revised ..... 1 ..... 111  
CR-2 ..... 2 ..... 850  
CR-4, CR-6 ..... 2 ..... 851  
CR-8 ..... 2 ..... 852  
CR-9 ..... 2 ..... 853  
CR-12 ..... 2 ..... 852  
CR-501, CR-503, CR-505 ..... 3 ..... 1288  
RT-14 ..... 2002  
UN6-100 ..... 1 ..... 336  
UN6-450, UN6-500 ..... 1 ..... 335  
UT-21A ..... 2003  
UT-21B ..... 2004  
18BU3000, 18BU3001 ..... 1995  
18BU3002 ..... 2005  
18BU3100, L, RM ..... 1995  
18BU3102, L ..... 2005  
18BU3104 ..... 1995  
22BU4000 ..... 1995  
22BU4002, 22BU4003 ..... 2005

**PHILCO (Continued)**

22BU4008, 22BU4009 ..... 1995  
22BU4100, L, 22BU4101 ..... 1995  
22BU4102, L, 22BU4106 ..... 2005  
22BU4108 ..... 1995  
22BU4109HM ..... 2005  
22BU4110, L ..... 1995  
22BU4302 ..... 2005  
22BU4303 ..... 1995  
22BU4304, 22BU4306, 22BU4307HM ..... 2005  
22BU4308 ..... 1995  
22C4016, 22C4020 ..... 2006  
22C4119, 22C4120, L, 22C4123, 22C4124, L, 22C4126, L, 22C4128M, 22C4129, 22C4131 ..... 2006  
22C4310, L, 22C4312, 22C4316, L, 24BU6300 ..... 2005  
39-40, 39-45 ..... 1 ..... 339  
39-55 ..... 1 ..... 342  
39-116 ..... 1 ..... 342  
39-770 ..... 1 ..... 338  
40-110 ..... 1 ..... 341  
40-130, 40-135, 40-140, 40-145 ..... 1 ..... 340  
40-150, 40-155 ..... 1 ..... 344  
40-158 ..... 1 ..... 348  
40-160, 40-165 ..... 1 ..... 345  
40-170CS ..... 1 ..... 340  
40-180, 40-185, 40-190, 40-195, 40-200, 40-201 ..... 1 ..... 338  
40-205, 40-215, 40-216, 40-217 ..... 1 ..... 942  
40-503, 40-506, 40-507 ..... 1 ..... 340  
40-516 ..... 1 ..... 242  
40-525, 40-526, 40-527 ..... 1 ..... 340  
40-710, 40-715 ..... 1 ..... 351  
40-725, 40-748, 40-755, 40-756, 40-780 ..... 1 ..... 349  
40-2710 ..... 1 ..... 351  
40-2725, 40-2780 ..... 1 ..... 349  
41-230, 41-235 ..... 1 ..... 350  
41-250, 41-255 ..... 1 ..... 353  
41-260, 41-265 ..... 1 ..... 352  
41-280, 41-285, 41-287, 41-290 ..... 1 ..... 353  
41-295 ..... 1 ..... 338  
41-296 ..... 1 ..... 353  
41-300, 41-315X ..... 1 ..... 338  
41-316 ..... 1 ..... 342  
41-608, 41-609 ..... 1 ..... 355  
41-610, 41-611 ..... 1 ..... 353  
41-616 ..... 1 ..... 342  
41-629 ..... 1 ..... 353  
41-712, 41-713 ..... 1 ..... 354  
41-714 ..... 1 ..... 346  
41-722, 41-745, 41-758, 41-759 ..... 1 ..... 347  
41-788 ..... 1 ..... 356  
42PT-2, 42PT-4, 42PT-7 ..... 1 ..... 343  
46-42 ..... 1 ..... 363  
42-122 ..... 1 ..... 358  
42-123 ..... 1 ..... 361  
42-124, 42-125, 42-126 ..... 1 ..... 364  
42-35 ..... 1 ..... 357  
42-380 ..... 1 ..... 363  
42-395 ..... 1 ..... 363  
42-400 ..... 1 ..... 338  
42-706 ..... 1 ..... 343  
42-724 ..... 1 ..... 360  
42-730 ..... 1 ..... 366  
42-760, 42-761, 42-762 ..... 1 ..... 359  
42-788 ..... 1 ..... 356  
42-1002 ..... 1 ..... 362  
42-1003, 42-1005, 42-1006, 42-1008, 42-1009 ..... 1 ..... 367  
42-1010, 42-1011, 42-1012, 42-1013, 42-1015, 42-1016 ..... 1 ..... 370  
46-131 ..... 1 ..... 370  
46-131 Revised ..... 2 ..... 854  
46-132 ..... 1 ..... 371  
46-142 ..... 2 ..... 854  
46-200, 46-200-I, 46-201, 46-202, 46-203 ..... 1 ..... 173  
46-250, 46-250-I, 46-251 ..... 1 ..... 372  
46-350 ..... 1 ..... 373  
46-420, 46-420-I ..... 1 ..... 377  
46-421, 46-421-I ..... 1 ..... 374  
46-427 ..... 1 ..... 375  
46-480 ..... 1 ..... 376  
46-1201 ..... 1 ..... 379  
46-1203 ..... 1 ..... 378  
46-1209 ..... 1 ..... 380  
46-1213 ..... 1 ..... 382  
46-1226 ..... 1 ..... 380  
47-204, 47-205 ..... 2 ..... 745  
47-1227 ..... 2 ..... 855  
47-1230 ..... 2 ..... 856  
48-141, 48-145 ..... 2 ..... 837  
48-150 ..... 2 ..... 858  
48-200, 48-200-I, 48-209, 48-214, 48-225, 48-230, 48-250, 48-250-I ..... 2 ..... 850  
48-300, 48-360 ..... 2 ..... 880  
48-460, 48-460-I ..... 2 ..... 861  
48-461 ..... 2 ..... 859  
48-464 ..... 2 ..... 882  
48-472-I ..... 2 ..... 863  
48-472 Revised ..... 2 ..... 864  
48-475 ..... 2 ..... 865  
48-482 ..... 2 ..... 866  
48-485 ..... 2 ..... 867  
48-1201 ..... 2 ..... 868  
48-1253 ..... 2 ..... 869  
48-1256 ..... 2 ..... 870  
48-1260 ..... 2 ..... 868  
48-1264 ..... 2 ..... 871  
48-1263 ..... 2 ..... 871  
48-1264 ..... 2 ..... 872  
48-1266 ..... 2 ..... 856  
48-1270 ..... 2 ..... 873  
48-1274, 48-1276 ..... 2 ..... 874  
48-1282 ..... 2 ..... 867  
48-1284 ..... 2 ..... 875  
48-1286 ..... 2 ..... 867  
48-1290 ..... 2 ..... 873  
48-2500, 48-2500-5, 49-101, 49-500, 49-500-I ..... 3 ..... 1289  
49-503 ..... 2 ..... 745  
49-504, 49-504-I ..... 2 ..... 560  
49-505 ..... 2 ..... 859  
49-505 ..... 2 ..... 876  
49-506 ..... 2 ..... 745  
49-601, 49-602 ..... 2 ..... 877  
49-605, 49-607 ..... 2 ..... 878  
49-900E, 49-900-I ..... 2 ..... 879  
49-902 ..... 2 ..... 745  
49-904 ..... 2 ..... 880  
49-905 ..... 2 ..... 881  
49-906 ..... 2 ..... 882  
49-909 ..... 2 ..... 883  
49-1076, 49-1077 (Radio Ch.) ..... 3 ..... 1291  
49-1100 ..... 2 ..... 867  
49-1101 ..... 2 ..... 883  
49-1175 (Code 122 & Code 124), 49-1278 (Code 123), 49-1279, 49-1280 ..... 3 ..... 1291  
49-1401 ..... 2 ..... 884  
49-1405 ..... 2 ..... 885  
49-1475, 49-1480 (Codes 121A or B, 123A or B, 123TA or B), 49-1600, 49-1601, 49-1602, 49-1603, 49-1604, 49-1605 ..... 2 ..... 886  
49-1606, 49-1607 ..... 2 ..... 883  
49-1613 ..... 3 ..... 1293  
50-T701, 50-T702, 50-T1104, 50-T1105, 50-T1106 ..... 3 ..... 1294  
50-T1400, 50-T1401, 50-T1402 ..... 3 ..... 1294

**PHILCO (Continued)**

42-1012, 42-1013M, 42-1013W ..... 1 ..... 368  
42-1015, 42-1016 ..... 1 ..... 338  
46-131 ..... 1 ..... 370  
46-131 Revised ..... 2 ..... 854  
46-132 ..... 1 ..... 371  
46-142 ..... 2 ..... 854  
46-200, 46-200-I, 46-201, 46-202, 46-203 ..... 1 ..... 173  
46-250, 46-250-I, 46-251 ..... 1 ..... 372  
46-350 ..... 1 ..... 373  
46-420, 46-420-I ..... 1 ..... 377  
46-421, 46-421-I ..... 1 ..... 374  
46-427 ..... 1 ..... 375  
46-480 ..... 1 ..... 376  
46-1201 ..... 1 ..... 379  
46-1203 ..... 1 ..... 378  
46-1209 ..... 1 ..... 380  
46-1213 ..... 1 ..... 382  
46-1226 ..... 1 ..... 380  
47-204, 47-205 ..... 2 ..... 745  
47-1227 ..... 2 ..... 855  
47-1230 ..... 2 ..... 856  
48-141, 48-145 ..... 2 ..... 837  
48-150 ..... 2 ..... 858  
48-200, 48-200-I, 48-209, 48-214, 48-225, 48-230, 48-250, 48-250-I ..... 2 ..... 850  
48-300, 48-360 ..... 2 ..... 880  
48-460, 48-460-I ..... 2 ..... 861  
48-461 ..... 2 ..... 859  
48-464 ..... 2 ..... 882  
48-472-I ..... 2 ..... 863  
48-472 Revised ..... 2 ..... 864  
48-475 ..... 2 ..... 865  
48-482 ..... 2 ..... 866  
48-485 ..... 2 ..... 867  
48-1201 ..... 2 ..... 868  
48-1253 ..... 2 ..... 869  
48-1256 ..... 2 ..... 870  
48-1260 ..... 2 ..... 868  
48-1264 ..... 2 ..... 871  
48-1263 ..... 2 ..... 871  
48-1264 ..... 2 ..... 872  
48-1266 ..... 2 ..... 856  
48-1270 ..... 2 ..... 873  
48-1274, 48-1276 ..... 2 ..... 874  
48-1282 ..... 2 ..... 867  
48-1284 ..... 2 ..... 875  
48-1286 ..... 2 ..... 867  
48-1290 ..... 2 ..... 873  
48-2500, 48-2500-5, 49-101, 49-500, 49-500-I ..... 3 ..... 1289  
49-503 ..... 2 ..... 745  
49-504, 49-504-I ..... 2 ..... 560  
49-505 ..... 2 ..... 859  
49-505 ..... 2 ..... 876  
49-506 ..... 2 ..... 745  
49-601, 49-602 ..... 2 ..... 877  
49-605, 49-607 ..... 2 ..... 878  
49-900E, 49-900-I ..... 2 ..... 879  
49-902 ..... 2 ..... 745  
49-904 ..... 2 ..... 880  
49-905 ..... 2 ..... 881  
49-906 ..... 2 ..... 882  
49-909 ..... 2 ..... 883  
49-1076, 49-1077 (Radio Ch.) ..... 3 ..... 1291  
49-1100 ..... 2 ..... 867  
49-1101 ..... 2 ..... 883  
49-1175 (Code 122 & Code 124), 49-1278 (Code 123), 49-1279, 49-1280 ..... 3 ..... 1291  
49-1401 ..... 2 ..... 884  
49-1405 ..... 2 ..... 885  
49-1475, 49-1480 (Codes 121A or B, 123A or B, 123TA or B), 49-1600, 49-1601, 49-1602, 49-1603, 49-1604, 49-1605 ..... 2 ..... 886  
49-1606, 49-1607 ..... 2 ..... 883  
49-1613 ..... 3 ..... 1293  
50-T701, 50-T702, 50-T1104, 50-T1105, 50-T1106 ..... 3 ..... 1294  
50-T1400, 50-T1401, 50-T1402 ..... 3 ..... 1294



Name & Model or Chassis No.	Vol. 5 Diag. No.	Previous Vols. Vol. No. Diag. No.
--------------------------------	------------------------	--

**PHILCO (Continued)**

50-T1403,		
50-T1404,		
50-T1406 (Codes		
123, 124, 125)	3	1294
50-T1406 (Codes		
121 & 122)	3	1294
50-T1430	3	1294
50-T1432 (Code 122)	3	1294
50-T1432 (Code 124)	3	1294
50-T1476,		
50-T1477,		
50-T1478,		
50-T1479	3	1295
50-T1481,		
50-T1482,		
50-T1484	3	1295
50-520, 50-520-1	3	1296
50-522, 50-522-1,		
50-524	3	1297
50-526	3	1298
50-620	3	1299
50-621	3	1300
50-920, 50-921,		
50-922	3	1301
50-925, 50-926	3	1302
50-1420, 50-1423,		
50-1422, 50-1423	3	1303
50-1720	3	1304
50-1721, 50-1723,		
50-1724	3	1305
50-1727	3	1306
51-T1443PL, PM,		
PW (Radio Ch.)	3	1307
51-T1872,		
51-T1874, L,		
51-T1875,		
51-T1876	3	1308
51-T2175,		
51-T2176	3	1309
51-530, 51-532,		
51-534	3	1310
51-629	3	1311
51-631	3	1312
51-632	3	1311
51-930, -931, -932,	4	931
51-934	3	1313
51-1330	4	1649
51-1730, (L)	4	1650
51-1731, 51-1732	3	1314
51-1733, (L),		
51-1734	4	1651
52-540, -1,		
52-541, -1,		
52-542, -1,	4	1652
52-640, -941	4	1653
52-643	4	1654
52-940, -941,		
+942	4	1655
52-944	4	1656
52-1340	4	1649
53-T2285,		
-T2286, T2287	4	1646
53-591, -562	4	1657
53-593	4	1658
53-569	4	1659
53-651	4	1653
53-652	1997	
53-656, -658	4	1660
53-702, -706,		
-707	4	1657
53-800, -804	4	1661
53-950, -952,		
-954	4	1662
53-956	1998	
53-958	4	1663
53-960	4	1664
53-1350, -1750	4	1665
53-1754	4	1666

**Chassis**

R-181U,		
R-181	1995	
R-191U,		
D-191	2005	
R-201,		
D-201	1995	
R-207,		
D-208	2005	
TV-400	2006	
300, 301, 350,	2006	

**PHILHARMONIC**

100C	2	887
100T	2	888
149C, 249C,	2	889

Name & Model or Chassis No.	Vol. 5 Diag. No.	Previous Vols. Vol. No. Diag. No.
--------------------------------	------------------------	--

**PHILHARMONIC (Continued)**

349C	2	890
920, 924	2007	
5000, 5200, 5201,		
5250, 5400, 5401,		
5450, 5600, 5601,		
5650, 5700,		
5700RT, 5701,		
5750, 5750RT,		
5800	4	1530
6810	1	196
6701, 6702, 6703	1	196
6710, 6711, 6712	1	196
9120, 9121,		
9820, 9821	2007	

**PHILLIPS PETROLEUM CO.  
(See Woolaroc)**

**PILOT**

AF-605	4	1667
AF-723, U	2008	
AF-821A, U	4	1668
AF-824	2009	
AF-865	2010	
FM-607	2011	
T-411-U	1	381
T-500	1	73
T-510, T-511	1	381
T-521	1	383
T-530	1	393
T-601	2	614
T-741	2	891

**POLICE ALARM**

PR-8	3	1315
PR-31	3	1316

**PONTIAC**

983667	1	384
983679	1	386
983680	1	394
983775	1	386
983910	1	108
983911	1	386
984170	1	108
984171	1	386

**PORTO BARDIO**

PA510, PB520	2	892
--------------	---	-----

**PREMIER**

15LW	1	127
------	---	-----

**PURE OIL (See Puritan)**

**PURITAN**

501	1	385
501X	1	124
502	1	385
503	1	124
503, 503W	1	388
504, 504W	1	387
506, 506X, 507,		
507W	1	20
508	1	25
509	2	893
515	2	894

**RCA VICTOR**

A55	3	1317
A-82	4	1669
A-106	3	1318
A-108	4	1670
BK-42, BT-42	1	427
BX6	3	1319
BX55, BX57	3	1320
B-52	1	419
E-80	1	43
HF-2, HF-4	1	390
HF-6, HF-8	1	401
K-50	1	107
K-60	1	434
K-61	1	107
K-62, K-81, K-82	1	434
K-105	1	434
M-50, M-60	1	409
M-70	1	439
MI-12107	2012	
PX800	4	1671
Q-11, Q-12	4	397

Name & Model or Chassis No.	Vol. 5 Diag. No.	Previous Vols. Vol. No. Diag. No.
--------------------------------	------------------------	--

**RCA VICTOR (Continued)**

Q-14, Q-14E,		
Q-15, Q-15E	1	412
Q-16, Q-16E, Q-17	1	416
Q-18	1	398
Q-22, Q-22A	1	391
Q-23	1	416
Q-24	1	391
Q-25	1	420
Q-26	1	396
Q-27	1	420
Q-30, Q-31	1	423
Q-33	1	399
Q-44	1	426
QB-1, QB-2	1	391
QB-3	1	399
QB-5	1	397
QB-6, QB-9	1	391
QH-51C	1	428
QK-23	1	392
QU-2C, QU-2M	1	392
QU-3C, QU-3M	1	396
QU-5	1	392
QU-7, QU-8	1	407
QU-51M	1	428
QU-52C, QU-52M	1	392
QU-55	1	430
QU-56C, QU-56M	1	432
ST-1	2012	
SVT-1	2013	
T-55, T-56, T-60,		
T-62, T-63	1	107
T-64, T-65, T-80	1	433
TA-128, TA-128,		
TA-169	3	1321
TRK-5	1	395
TRK-9, TRK-12	1	410
TRK-90, TRK-12	1	410
TT-5	1	395
U-10, U-12, U-20	1	107
U-25, U-26	1	395
U-30	1	414
U-40, U-42, U-43	1	107
U-44, U-45	1	425
U-50	1	400
U-70	4	1872
U-115	1	443
U-119	1	395
U-121	1	443
U-122E	1	395
U-123 (1 band)	1	443
U-123 (2 band)	1	441
U-124, U-125	1	395
U-126	1	414
U-127E	1	443
U-128, U-129	1	414
U-130	1	390
U-132, U-134	1	401
V-101	1	440
V-102	1	413
V-140	1	446
V-170, V-175	1	413
V-200	1	139
V-201	1	139
V-205	1	447
V-209, V-210	1	142
V-215, V-219,		
V-221, V-225	1	142
V-300, V-301,		
V-302	1	447
V-405	1	447
VHR-202, VHR-207	1	447
VHR-212	1	142
VHR-307, VHR-407	1	447
X-55, X-60	1	107
X711	3	1322
1R81	4	1673
1X591, 1X592	4	1671
2BX63	4	1674
2C521, 2C522,		
2C527	4	1675
257	2014	
2510	4	1676
2U57	4	1677
2X61, 2X62,		
2X621	4	1678
2XF91, 2XF931,		
2XF932, 2XF933,		
2XF934	4	1679
3BX671	2015	
3R F91	2016	
4C671, 4C672	2017	
4T141	3	1323
4X641	2018	
4X661	2019	
4X511	2020	
5BX41	2021	
5C581	2022	

Name & Model or Chassis No.		Vol. 5 Diag. No.	Previous Vols. Vol. No. Diag. No.	Name & Model or Chassis No.		Vol. 5 Diag. No.	Previous Vols. Vol. No. Diag. No.	Name & Model or Chassis No.		Vol. 5 Diag. No.	Previous Vols. Vol. No. Diag. No.
<b>RCA VICTOR (Continued)</b>				<b>RCA VICTOR (Continued)</b>				<b>RCA VICTOR (Continued)</b>			
5C591, 5C592 . . . . .	2022			21S548, N, NU, U (Radio Ch.)	2028			730TV1, 730TV2 (Radio Ch.)		2 . . . . .	906
5Q5, 5Q6, 5Q8 . . . . .		1 . . . . .	398	21S548NU, U (TV Ch.)	2026			910KG, 911K		1 . . . . .	414
5Q12, 5Q12A . . . . .		1 . . . . .	400	21S5022U, 21S5231U, 21S5232U	2024			<b>Chassis</b>			
5Q55, 5Q56, 5Q66 . . . . .		1 . . . . .	398	21T197DE, 21T242		4 . . . . .	1676	KCST70		4 . . . . .	1672
5X560, 5X562, 5X563 . . . . .	2023			21T244		4 . . . . .	1681	KCST8H, J . . . . .	2024		
6QU . . . . .		1 . . . . .	400	24D542U, 24D543U				KCS84H, K . . . . .	2026		
6Q1, 6Q4, 6Q4X . . . . .		1 . . . . .	402	24D544U . . . . .	2028			KCS88F, H . . . . .	2027		
6Q7, 6Q8, 6QK8 . . . . .		1 . . . . .	400	24S512U, 24S513U				KCS88J, JK, K, KX, L, LX, M, MX, VA, VAX . . . . .	2026		
6T84 . . . . .		3 . . . . .	1323	24S512U, 24S513U, 24S529U, 24S531U, 24S532U	2026			KCS89A, C . . . . .	2026		
7QB, 7QBK . . . . .		1 . . . . .	403	25BK . . . . .		1 . . . . .	418	KCS90A . . . . .	2026		
7Q4, 7Q4X, 7QK4 . . . . .		1 . . . . .	405	25B2T . . . . .		1 . . . . .	418	KCS92D, DX, E, EX, F, FX, H, HX, M, MX, NU . . . . .	2026		
7T143 (Radio Ch.) . . . . .		3 . . . . .	1327	25B2T2 . . . . .		1 . . . . .	419	RC-604, RC-605 . . . . .	1 . . . . .	142	
8BX6, 8BX65 . . . . .		2 . . . . .	895	25B73 . . . . .		1 . . . . .	418	RC-606 . . . . .	1 . . . . .	437	
8QB, 8QBK . . . . .		1 . . . . .	403	26BP . . . . .		1 . . . . .	421	RC-608C . . . . .	2 . . . . .	905	
8Q1 . . . . .		1 . . . . .	406	28X1, 26X3, 26X4 . . . . .		1 . . . . .	397	RC-608 . . . . .	2 . . . . .	901	
8Q2 . . . . .		1 . . . . .	404	27K . . . . .		1 . . . . .	422	RC-610B, RC-610A, RC-610E . . . . .	2 . . . . .	906	
8Q4 . . . . .		1 . . . . .	406	28T . . . . .		1 . . . . .	139	RC-613 . . . . .	2 . . . . .	906	
8QU5C, 8QU5M . . . . .		1 . . . . .	404	28X, 28X5 . . . . .		1 . . . . .	140	RC-615 . . . . .	2 . . . . .	904	
8RT1, 8RT2, 8RT4, 8RT5, 8RT6 . . . . .		2 . . . . .	896	29K, 29K2 . . . . .		1 . . . . .	141	RC-616, RC-616A, RC-616B, RC-616A . . . . .	3 . . . . .	897	
8TK29 (Radio Ch.) . . . . .		3 . . . . .	1324	34X, 35X . . . . .		1 . . . . .	411	RC-616H . . . . .	3 . . . . .	1325	
8TK320 . . . . .		3 . . . . .	1324	36K . . . . .		1 . . . . .	397	RC-616H, K . . . . .	3 . . . . .	1325	
8TR29 . . . . .		3 . . . . .	1324	45-W-10 . . . . .		4 . . . . .	1682	RC-618 . . . . .	3 . . . . .	1325	
8TV321, B, 8TV323, B . . . . .		3 . . . . .	1325	45X18 . . . . .		1 . . . . .	429	RC-618A, RC-618A (Model 8V90) . . . . .	2 . . . . .	897	
8V90, 8V91 . . . . .		2 . . . . .	897	55AU . . . . .		1 . . . . .	419	RC-618, RC-618B, RC-618C (Model 9W101) . . . . .	3 . . . . .	1328	
8V111, 8V112 . . . . .		2 . . . . .	897	55AU, 55FA . . . . .		1 . . . . .	429	RC-622 . . . . .	3 . . . . .	1318	
8X53 . . . . .		2 . . . . .	898	55U . . . . .		1 . . . . .	431	TC-1004E . . . . .	1 . . . . .	419	
9BX36 . . . . .		3 . . . . .	1326	56X, 56X2, 56X3 . . . . .		1 . . . . .	397	RC-1011, RC-1017A . . . . .	1 . . . . .	429	
9M1, 9M2 . . . . .		1 . . . . .	409	56X5, 56X10, 56X11 . . . . .		1 . . . . .	397	RC-1023B . . . . .	1 . . . . .	397	
9QK, 9Q1 . . . . .		1 . . . . .	408	58AV, 58V, 58AV, 59V1 . . . . .		1 . . . . .	142	RC-1037 . . . . .	1 . . . . .	138	
9Q4 . . . . .		1 . . . . .	405	64F1, 64F2, 64F3 . . . . .		1 . . . . .	138	RC-1037, RC-1037A . . . . .	1 . . . . .	138	
9T89 . . . . .		3 . . . . .	1327	65AU . . . . .		1 . . . . .	429	RC-1038, RC-1038A . . . . .	1 . . . . .	436	
9T147 . . . . .		3 . . . . .	1327	65BR9 . . . . .		2 . . . . .	899	RC-1040, RC-1040A . . . . .	1 . . . . .	435	
9TW333 . . . . .		3 . . . . .	1325	65U . . . . .		1 . . . . .	429	RC-1040C . . . . .	2 . . . . .	895	
9W101, 9W102, 9W103, 9W105 . . . . .		3 . . . . .	1328	65X1, 65X2 . . . . .		1 . . . . .	138	RC-1045 . . . . .	2 . . . . .	899	
9X561, 9X562 . . . . .		3 . . . . .	1329	66BX . . . . .		1 . . . . .	435	RC-1045 . . . . .	2 . . . . .	895	
9X571, 9X572 . . . . .		3 . . . . .	1329	66X1, 66X2, 66X3, 66X4, 66X9 . . . . .		1 . . . . .	436	RC-1046 . . . . .	2 . . . . .	900	
9X641, 9X642 . . . . .		3 . . . . .	1330	66X11, 66X12, 66X13, 66X14, 66X15 . . . . .		2 . . . . .	900	RC-1050, RC-1050B . . . . .	2 . . . . .	900	
9X651, 9X652 . . . . .		3 . . . . .	1331	67AV1, 67V1 . . . . .		1 . . . . .	437	RC-1057A . . . . .	2 . . . . .	903	
9Y7 . . . . .		4 . . . . .	1680	68R1, 68R2, 68R3, 68R4 . . . . .		2 . . . . .	901	RC-1057B . . . . .	4 . . . . .	1680	
9Y51 . . . . .		3 . . . . .	1332	70T1, 70T2 . . . . .		2 . . . . .	902	RC-1060, RC-1060A . . . . .	2 . . . . .	896	
9Y510, 9Y511 . . . . .		3 . . . . .	1332	77U . . . . .		2 . . . . .	903	RC-1064 (Model 8X53) RC-1064 (Model 65X1) . . . . .	2 . . . . .	898	
10Q1 . . . . .		1 . . . . .	406	77V1 . . . . .		2 . . . . .	904	RC-1068 . . . . .	3 . . . . .	1326	
10X . . . . .		1 . . . . .	411	77V2 . . . . .		2 . . . . .	905	RC-1070A . . . . .	3 . . . . .	1322	
11QK, 11Q1U, 11Q4 . . . . .		1 . . . . .	414	94BK2, 94BT2 . . . . .		1 . . . . .	442	RC-1077, A, B . . . . .	3 . . . . .	1332	
11X1 . . . . .		1 . . . . .	411	95T5, 95T5LW . . . . .		1 . . . . .	443	RC-1079, A, B, C . . . . .	3 . . . . .	1329	
12AK, 12AX2 . . . . .		1 . . . . .	411	96BK6, 96BT6 . . . . .		1 . . . . .	442	RC-1079K, L . . . . .	4 . . . . .	1671	
12QK, 12Q1U, 12Q4 . . . . .		1 . . . . .	414	96E . . . . .		1 . . . . .	443	RC-1082 . . . . .	3 . . . . .	1319	
12X, 12X2 . . . . .		1 . . . . .	411	96E2 . . . . .		1 . . . . .	395	RC-1085, A . . . . .	3 . . . . .	1331	
14AX, 14AX2, 14X, 14X2 . . . . .		1 . . . . .	411	96K, 96K2, 96K5, 96K6 . . . . .		1 . . . . .	395	RC-1085B . . . . .	4 . . . . .	1678	
15X . . . . .		1 . . . . .	397	96T, 96T1 . . . . .		1 . . . . .	443	RC-1087 . . . . .	3 . . . . .	1317	
16K, 16T2 . . . . .		1 . . . . .	413	96T2, 96T3 . . . . .		1 . . . . .	395	RC-1088, A . . . . .	3 . . . . .	1320	
16T3, 16T . . . . .		1 . . . . .	413	96T4, 96T5, 96T6 . . . . .		1 . . . . .	441	RC-1090 . . . . .	3 . . . . .	1323	
16X4 . . . . .		1 . . . . .	415	96T7 . . . . .		1 . . . . .	395	RC-1092 . . . . .	3 . . . . .	1327	
16X11, 16X13 . . . . .		1 . . . . .	397	96X1, 96X2, 96X3, 96X4 . . . . .		1 . . . . .	444	RC-1094 . . . . .	4 . . . . .	1669	
16X14 . . . . .		1 . . . . .	397	96X11, 96X12, 96X13, 96X14 . . . . .		1 . . . . .	444	RC-1096 . . . . .	4 . . . . .	1670	
17K . . . . .		1 . . . . .	139	97E, 97K, 97KG, 97K2 . . . . .		1 . . . . .	395	RC-1096A . . . . .	4 . . . . .	1682	
17S349U . . . . .				97T, 97T2 . . . . .		1 . . . . .	395	RC-1102 . . . . .	4 . . . . .	1673	
17S350U . . . . .				97T, 97T2 . . . . .		1 . . . . .	395	RC-1115 . . . . .	4 . . . . .	1674	
17S351U . . . . .				97X . . . . .		1 . . . . .	443	RC-1117A . . . . .	4 . . . . .	1677	
17S360U . . . . .	2024			97Y . . . . .		1 . . . . .	398	RC-1117C . . . . .	4 . . . . .	1676	
17T352U . . . . .				98EY . . . . .		1 . . . . .	395	RC-1117D . . . . .	1 . . . . .	1677	
17T361U . . . . .	2024			98K . . . . .		1 . . . . .	414	RC-1120, A . . . . .	4 . . . . .	1675	
18T . . . . .		1 . . . . .	139	98K2, 98T, 98T2 . . . . .		1 . . . . .	395	RC-1121, A . . . . .	4 . . . . .	1679	
19K . . . . .		1 . . . . .	417	98X, 98YG . . . . .		1 . . . . .	395	RC-1125 . . . . .	2015		
21D346U . . . . .	2025			99K, 99T . . . . .		1 . . . . .	414	RC-1129 . . . . .	2016		
21D527U . . . . .	2026			110K, 110K2, 111K . . . . .		1 . . . . .	445	RC-1134 . . . . .	2020		
21S348KU . . . . .				211K . . . . .		1 . . . . .	141	RC-1140 . . . . .	2018		
21S355KU . . . . .				515 . . . . .		1 . . . . .	397	RC-1141 . . . . .	2019		
21S357KU . . . . .				310, 317, 522, 526, 527 . . . . .		1 . . . . .	411	RC-1142 . . . . .	2017		
21S362KU . . . . .				610W1, 610V2 . . . . .		2 . . . . .	906	RC-1148A . . . . .	2022		
21S367KU . . . . .				612V1, 612V2 . . . . .				RC-1150 . . . . .	2023		
21S369KU . . . . .	2027			648PTK, 648PV (Radio Ch.) . . . . .		3 . . . . .	1333	RC-1151 . . . . .	2023		
21S501U . . . . .				710V2 . . . . .		2 . . . . .	906	RC-1152 . . . . .	2021		
21S502U . . . . .				711V1, 711V2 (Radio Ch.) . . . . .		3 . . . . .	1333	RC-1153 . . . . .	2021		
21S503NU, U . . . . .				711V3 . . . . .		2 . . . . .	907	RC-1154 . . . . .	2021		
21S504NU, U . . . . .								RC-1155 . . . . .	2019		
21S505U . . . . .								RC-1156 . . . . .	2017		
21S506NU, U . . . . .								RC-1157 . . . . .	2017		
21S507NU . . . . .								RC-1158 . . . . .	2017		
21S510NU . . . . .								RC-1159 . . . . .	2017		
21S511NU . . . . .								RC-1160 . . . . .	2017		
21S517U . . . . .								RC-1161 . . . . .	2017		
21S518U . . . . .								RC-1162 . . . . .	2017		
21S519NU, U . . . . .								RC-1163 . . . . .	2017		
21S521NU, U . . . . .								RC-1164 . . . . .	2017		
21S522NU, U . . . . .								RC-1165 . . . . .	2017		
21S523NU, U . . . . .								RC-1166 . . . . .	2017		
21S525U . . . . .								RC-1167 . . . . .	2017		
21S526NU, U . . . . .								RC-1168 . . . . .	2017		
21RS37NU, U . . . . .	2026							RC-1169 . . . . .	2017		
								RC-1170 . . . . .	2017		
								RC-1171 . . . . .	2017		
								RC-1172 . . . . .	2017		
								RC-1173 . . . . .	2017		
								RC-1174 . . .			



Name & Model or Chassis No.	Vol. 5 Diag. No.	Previous Vols. Vol. No. Diag. No.	Name & Model or Chassis No.	Vol. 5 Diag. No.	Previous Vols. Vol. No. Diag. No.	Name & Model or Chassis No.	Vol. 5 Diag. No.	Previous Vols. Vol. No. Diag. No.
<b>SILVERLINE</b>			<b>SILVERTONE (Continued)</b>			<b>SILVERTONE (Continued)</b>		
63A, 64.....	2046		4126, 4127.....	2054		6490, 6490-A.....	1	472
<b>SILVERTONE</b>			4127A.....	2063		6495, 6497.....	1	472
R-381.....	1	460	4128, 4129,		2054	6551, 6561.....	1	482
R-1161.....	1	458	4131, 4139.....	2054		6621, 6651.....	1	482
5, 6.....	4	1711	4140D, 4143D,		2054	6721, 6751, 6751-A.....	1	482
10, 11.....	4	1712	4145D, 4149.....	2054		6761, 6761-A.....	1	482
15, 16, 18.....	4	1713	4150D, 4153D,		2054	6921.....	1	482
25, 27.....	4	1714	4155D.....	2054		6950.....	207	
41, 41A.....	3	1351	4200.....	2064		7010.....	1	479
51, 53.....	3	1352	4204, 4206.....	2065		7021.....	1	481
54, 56.....	3	1352	4225.....	2066		7025.....	2	946
64, 65, 67.....	3	1353	4608, 4609.....	1	461	7034.....	1	479
69.....	4	1715	4628, 4629.....	1	461	7037.....	1	483
102A.....	4	1716	4638, 4639.....	1	461	7038.....	1	484
106, 107(Ch.).....			4648, 4649.....	1	461	7048.....	1	483
132, 889-2.....	4	1717	4666.....	1	465	7049.....	1	466
112.....	3	1354	4667.....	1	463	7054.....	1	469
120.....	3	1354	4686.....	1	465	7065, 7066.....	1	73
125.....	3	1355	4728, 4748.....	1	461	7067, 7068.....	1	466
141(Ch.).....			4768.....	1	465	7089, 7070.....	1	483
132, 889-2.....	4	1717	4767, 4777.....	1	463	7071.....	1	487
143, 143A.....	3	1356	4797, 4792.....	1	465	7080(Ch. 101, 809).....	1	486
144(Radio Ch.).....	4	1718	4798.....	1	463	7080(Ch. 101, 809-2).....	2	947
150-14, 163-16,	4	1719	5045, 5046.....	2067		7080-A.....	2	947
179-16, 180-16,			5101-A.....	2068		7085.....	2	948
194-16, 195-16.....	3	1357	5106, 5107, A,		2068	7086.....	2	949
220, 222, 223, 224.....	3	1358	5112A, C.....	2068		7090.....	1	488
225.....	3	1359	5113B.....	1844		7100.....	1	485
771.....	4	1720	5115, A, B, C,		2068	7102.....	2	948
1010, 1018.....	4	1720	D, 5117, A,		2068	7103.....	2	949
1040, A, 1045, A,	4	1721	C, D.....	2068		7104, 7106.....	1	491
1052, A, 1053, A,			5125, 5127, A, B,			7111.....	2	950
1054, A, 1055, A,	4	1722	C, 5129, A, B,			7112.....	1	491
1058, 1059,			C, D, 5131, A,		2068	7115, 7116, 7117.....	1	490
1062, 1063.....	4	1723	B, C, D.....	2069		7167, 7168.....	1	466
1771.....	1	458	5227.....	2069		7210.....	2	951
1781, 1781A.....	1	462	5502.....	1	400	7220.....	1	478
2003, 2004, 2005,			5511, 5511-A.....	1	450	7225.....	2	952
2006.....	4	1724	5571, 5571-A.....	1	460	7228.....	1	410
2009, 2010, 2011,			5581.....	1	458	7230.....	1	395
2012, 2013.....	4	1725	5601-A.....	1	460	7245.....	1	492
2011.....	1	73	5621.....	1	458	7905.....	1	396
2014, 2015, 2016,			6008, 6009.....	1	464	7915.....	1	408
2022.....	4	1722	6011, 6012.....	1	467	8005.....	2	953
2023, 2024, 2025,			6016.....	1	464	8010.....	2	954
2026, 2027.....	4	1712	6016(Ch. 132, 820).....	2	944	8020.....	2	955
2028.....	4	1726	6017, 6018,			8024, 8025.....	3	1361
2051.....	1	73	6019, 6022.....	1	464	8050.....	2	956
2056, 2060, 2061.....	4	1727	6036, 6038.....	1	470	8051.....	2	957
2063, 2064.....	4	1723	6046, 6047, 6048,		470	8080.....	2	958
2200, 2202, 2203.....	4	1728	6049.....	1	464	8083, 8083-A.....		
2225.....	4	1729	6050.....	1	464	8084, 8084-A.....	2	947
2276, 2277.....	2047		6051, 6052.....	1	468	8090.....	2	959
2411.....	1	73	6058, 6069.....	1	464	8100, 8101,		
2461.....	1	458	6071.....	1	6	8101-A, 8101-B,		
2511.....	1	73	6072.....	1	469	8101-C.....	2	947
2761.....	1	458	6074, 6079.....	1	470	8103.....	2	960
3004.....	2048		6092, 6093.....	1	466	8105, 8105A.....	2	947
3025, 3026.....			8100.....	1	73	8124, 8125, 8126,		
3027.....	2049		6104, 6105.....	1	466	8127, A, B, C,		
3040.....	4	1730	6106A, 6111A.....	2	945	8128, A, B, C.....	2	961
3040A.....	4	1730	6111.....	1	466	8132, 8133.....	3	1362
3045, 3046.....			6122, 6132.....	1	464	8200, 8200.....	3	475
3052, 3053.....			6136, 6138.....	1	470	8210.....	3	1363
3054, 3055.....	2051		6146, 6148.....	1	464	8220, 8221, 8222.....	1	475
3058, 3059.....			6157.....	1	473	8230, 8231.....	2	952
3063, 3064.....			6168.....	1	464	9005, 9006.....	3	1364
3067.....	2052		6190.....	1	474	9022.....	3	1365
3068.....	2053		6200-A.....	1	475	9101, 9102.....	2	947
3106.....	4	1515	6220, 6220-A.....	1	475	9105.....	3	1366
3109, 3110B,			6230, 6230-A.....	1	477	9115, 9116.....	3	1367
3112B.....	2054		6285-A.....	1	478	9122.....	3	1362
3136.....	2077		6286, 6287.....	4	1731	9133, 9134.....	3	1368
3150L, 3151B,			6293.....	3	1360	9270.....	3	1379
C, 3170D.....	2054		6301.....	1	474	9280.....	3	1370
3175.....	4	1515	6303.....	1	476	41122, 41292,		
3181, 3185.....	2077		6320.....	1	480	41312, A.....	2068	
3200, 3202.....			6321, 6322, 6323,			<b>Chassis</b>		
3276, 3277.....	2047		6324.....	1	471	100, 111.....	3	1356
3376, 3377.....	2056		6325, 6335, 6336,			100, 117A.....	2051	
4016, 4017.....	2057		6337.....	1	472	100, 176.....	2062	
4025, 4026.....	2058		6346, 6346A.....	1	472	100, 201.....	4	1715
4041, B.....	2059		6359, 6360, 6361,			100, 425-2.....		
4045A, B, C,			6362, 6363, 6364.....	1	472	-4, -A.....	2077	
4046A, B, C.....	2060		6368, 6379, 6380,			101, 660-1A.....	1	73
4056, 4057.....	2061		6381, 6382.....	1	472	101, 662-2B,		
4068A.....	2062		6407, 6408, 6409.....	1	472	101, 662-2D,		
4111.....	2054		6421, 6424.....	1	471	101, 662-3C.....	1	466
4112B.....	1844		6425, 6435, 6436,			101, 662-4E,		
4113, 4114,			6437, 6438, 6438-A,			101, 662-5F.....	2	945
4115, 4116,			6438-B, 6439,			101, 666-1B.....	1	478
4117, 4118,			6439-A, 6440,			101, 872-1A,		
			6441.....	1	471	101, 872-1B.....	1	466
			6446.....	1	472			
			6447.....	1	471			

Name & Model or Chassis No.	Vol. 5 Diag. No.	Previous Vols. Vol. No. Diag. No.
SILVERTONE (Continued)		
101. 800-1,		
101. 800-1A	1	475
101. 800-3	1	475
101. 801-1A	1	475
101. 802,		
101. 802-1	1	477
101. 807,		
101. 807A	1	481
101. 808	1	489
101. 809	1	486
101. 809-1A,		
101. 809-1B	2	947
101. 809-2,		
101. 809-3C	2	947
101. 810	1	488
101. 811	1	485
101. 813	2	956
101. 814,		
101. 814-1A	2	948
101. 817	1	483
101. 819A	2	952
101. 820	2	951
101. 821	2	959
101. 822,		
101. 822A	2	962
101. 825,		
101. 825-1A,		
101. 825-1B	1	490
101. 829	2	947
101. 829-1	3	1362
101. 831,		
101. 831A,		
101. 831-1	2	961
101. 833	2	947
101. 835	2	952
101. 839	2	957
101. 846	3	1362
101. 852	2	958
101. 859	3	1368
101. 859-1,		
101. 859-2	3	1353
101. 860	4	1723
101. 860-3	2052	
101. 861, -1	4	1727
101. 864, 101. 866	3	1362
110. 451, 110. 452	1	468
110. 454	1	469
110. 466,		
110. 466-1	2	949
110. 473	2	960
132. 011, -1,		
132. 012-1,		
132. 021	4	1722
132. 022	4	1725
132. 024, -1, -2	4	1724
132. 026-3	4	1727
132. 026-6	2061	
132. 027	4	1722
132. 045, -1	4	1515
132. 053,		
132. 056	2051	
132. 066	2049	
132. 067	2065	
132. 807-2	2	946
132. 816,		
132. 816A	1	467
132. 820	1	464
132. 825-4	1	6
132. 826-1	1	6
132. 839	2	953
132. 840	2	954
132. 841	2	955
132. 858	3	1364
132. 871	3	1365
132. 875	3	1366
132. 877	4	1713
132. 881	4	1711
132. 884, -1, -2	4	1713
132. 887	3	1352
132. 888	3	1352
132. 889, -2	4	1717
132. 890	3	1357
132. 896, -1	4	1712
132. 08500	1844	
132. 245	3	1351
434. 140	2	950
456. 150-14,		
-18, -61	2047	
456. 200-111,		
-112, -113,		
-114, -115,		
-121, -122,		
-123, -124,		
-125	2056	
478. 206-1	3	1361
478. 222, 478. 224	3	1367
478. 240	4	1718

Name & Model or Chassis No.	Vol. 5 Diag. No.	Previous Vols. Vol. No. Diag. No.
SILVERTONE (Continued)		
478. 257	3	1355
478. 289	3	1354
478. 311	3	1354
478. 319, 478. 338	4	1719
528. 168	3	1370
528. 171-1	3	1359
528. 173	3	1358
528. 194	4	1721
528. 210, -1	4	1720
528. 229	4	1728
528. 230	4	1726
528. 233	4	1729
528. 253, 528. 254	4	1730
528. 259	2055	
528. 261, 528. 263,		
-1, -2, 528. 264,		
-1, -2, 528. 266,		
-1	2054	
528. 269	2063	
528. 270,		
528. 286	2054	
528. 304, -1	2059	
528. 306	2058	
528. 307	2066	
528. 311	2050	
528. 312, -1	2060	
528. 6286, -1, -3		
528. 6287, -1, -3	4	1731
528. 6293-2	3	1360
528. 31500,		
528. 31600,		
528. 31700	2068	
528. 33200	2069	
528. 33800		
528. 33900	2068	
528. 34200,		
528. 34600,		
528. 34601,		
528. 34602,		
528. 34603	2068	
528. 34900	2067	
547. 245	3	1369
549. 100-3	4	1716
725. 101-1	2070	
757. 110	4	1724
757. 130	2048	
757. 140	2064	
757. 150	2057	
SIMPLON		
CA-5	2	963
WV2V	1	494
SKY KNIGHT		
CB-500-P	1	6
SKYROVER		
N5-RD-250,		
N5-RD-251	1	20
SONORA		
RB-207, RBU-176	1	451
RCU-208	1	495
RDU-209	1	189
RET-210	2	964
RGMF-212,		
RGMF-230	2	965
RKRU-215	1	498
RMR-219, RMR-220	1	496
RMR-245	1	496
RQU-222	1	501
RX-223	1	497
WBRU-239	2	966
WDU-233,		
WDU-243	2	967
WEU-262	2	968
WKRU-254A	2	969
WLRU-219A,		
WLRU-220A	2	970
WLRU-254A	2	970
100	2	971
101, 102	2	972
171, 172	3	1371
306	3	1372
314, 315, 379	2071	
389, 390	2072	
401	2	969
441, 442	2071	
458, 459	2071	
477, 478	2071	

Name & Model or Chassis No.	Vol. 5 Diag. No.	Previous Vols. Vol. No. Diag. No.
SOUND, INC.		
5R2	2	973
SPARTON		
4AW17, 4AW17A	2	974
5AM26PS	1	500
5A116	2	974
5AW06	1	503
5AW18	2	974
6AM06	2	975
6AW26PA	1	502
6-66A	2	976
7AM46, 8AM46	1	499
10AB76-PA,		
10AM76-PA,		
10BM76-PA,		
10W76-PA	1	504
100, 101	2	974
121	2	977
141	2	977
141A	3	1373
141XX	3	1374
150, 151, 152, 155	3	1375
1000, 1001, 1003	2	978
1005, 1006, 1007,		
1008	2	979
1010	2	980
1015	1	504
1020, 1021, 1023	2	978
1030, 1030A,		
1031, 1031A	2	981
1051, 1052	2	982
1056, 1059, 1060,		
1061, 1064, 1072	2	977
1080	3	1376
1080A	3	1373
1081	3	1376
1081A	3	1373
1210, 1211	3	1374
4900TV (Radio Ch.),	3	1376
4916, 4917, 4918,		
(Radio Ch.)	4	1732
5082, 5083		
(Radio Ch.)	3	1374
5088, 5089, 5090		
(Radio Ch.)	3	1374
5182, 5183, 5188,		
5189 (Radio Ch.)	3	1374
23312, 23313,		
23322, 23323	2074	
24542, 25544	2075	
Chassis		
PC-5-6-26	1	502
4E10	3	1375
5A7	2	974
5-06	1	503
5-16	2	974
5-26PS	1	500
6B9	2	982
6L8	1	981
6S10	4	1732
6-06	2	975
7L7	2	980
7-46	1	499
8L9	2	977
8L10	3	1373
8W10	3	1374
8-46	1	499
8-57	2	979
9L8A	3	1376
10-77PA	1	504
12L7	2	978
29U213	2074	
29U273	2075	
417, 417A	2	974
666A	2	976
STARRET		
Gotham	3	1377
John Hancock	3	1378
STEELMAN		
AF1100	4	1733
3AR3	2076	
6000	4	1734
STEWART-WARNER		
A51T1, A51T2,		
A51T3, A51T4	1	515
A61CR1, A51CR2,		
A61CR3, A51CR4	2	985



Name & Model or Chassis No.	Vol. 5 Diag. No.	Previous Vols. Diag. No.
1-512-2,		
1-513-2, -4	2084	
1-514-4, -6,		
1-518-2, -6	2083	
1-522-2	2088	
1-527-2	2085	
1-530-2,		
-4, -6	2083	
1-601-1		4
1-602-2, -3	2087	
1-602-4, -5,		
-6, -7	2086	
1-603-1		4

### TELESONIC

1635	1	6
1636	2	999
1642	1	167
1643	2	1000

### TELEPHONE

TV-208	3	1397
TV208TR	3	1398
TV-220	3	1398
TV-250	3	1399
TV-254, TV-255,		
TV-256	3	1399
TV-282	3	1400
TV-283	3	1399
TV-284	3	1398
TV-285	3	1399
TV-300, TV-301		
(Ch. TW)	3	1401
TV-304, TV-305		
(Ch. TX)	3	1401
TV-306, TV-307,		
TV-308	3	1398
TV-314	3	1402
TV-416	3	1403
TV-318, TV-322,		
TV-323	3	1404
TV-324, TV-325,		
TV-326	3	1405
TV-328, TV-329	3	1405
TV-330, TV-331,		
TV-332, TV-333	3	1398
TV-335, TV-336	3	1405
TV-340, TV-345,		
TV-348, TV-349		
TV-352	3	1405
TV-358, TV-359	3	1405
100, 100A, 101	2	1001
109	1	258
111, 113	2	1001
117-A	1	258
122, 123, 125, 127,		
130, 131	2	1001
133, 134	1	258
135	1	260
138	2	1002
142, 143, 144, 145	2	1003
148	2	1004
150	2	1005
156	2	1006
157	2	1005
158	2	1008
159	2	1007
160	2	1009
161, 162	2	1005
166, 167, 168,		
171	2	1005
172	2	1006
174	2	1005
176	2	1006
185	2	1010
198	2	1008
206	3	1406
228	4	1750
235	4	1751

### Chassis

Series A	2	1001
Series AA	2	1007
Series AE	2	1005
Series AH	2	1010
Series AT	2	1008
Series BL	4	1750
Series BQ	4	1751
Series C, CA, D	1	258
Series H	1	260
Series J	1	258
Series N	2	1002
Series P	2	1003
Series S	2	1004

Name & Model or Chassis No.	Vol. 5 Diag. No.	Previous Vols. Diag. No.
Series T	2	1005
TAC	3	1398
TAH	3	1403
TAJ	3	1402
TAM	3	1404
TAO	3	1398
TAP, TAP-1,		
TAP-2	3	1405
TS	3	1399
TV, TX	3	1401
TV, TZ	3	1398
Series U	2	1006
Series Y	2	1009

### TELEVOX

RP	2	1011
----	---	------

### TEMPLE

E510	1	189
E511	1	11
E519	1	189
F611	1	324
F616	1	523
F617	1	524
G410	2	893
G513	2	1012
G515, G516	1	189
G518	2	564
G521	2	565
G522	2	564
G622	2	1013
G623	2	1014
G721, G722, G723	2	1015
G724	2	566
G725	2	567
G1430	2	1016
H622	2	1014

### TEMPOTONE

500E Series	1	269
-------------	---	-----

### TRAV-LER

12L50, 12L50A	3	1407
14B50, A, 14C50, A	3	1407
16G50A, 16R50A,		
16T50A	3	1407
20A50	4	1752
55-37	2089	
55-38	2089	
62R50, 63R50	4	1752
64R50, -1, -2,		
65G50, -1, -2,		
75A50, -1, -2	4	1752
219-8A, -8B,	4	1753
5000, 5000-I	1	11
5002	1	73
5007, 5008, 5009,		
5010, 5011, 5012	1	18
5015, 5019	2	572
5020	1	73
5021	2	936
5022	3	1408
5027	2	574
5028, 5029	2	574
5030, 5031	2	572
5036	2	1017
5051	2	936
5060, 5061	3	1409
5066	2	1005
5091	2091	
5100	4	1754
5370	2092	
5310	2093	
5372	2094	
6040	2	1018
6050	2	1019

### Chassis

11A2	4	1753
32A1	4	1752
104, 105	1	18
109	1	73
800	2	936

### TRUETONE

D705	1	80
D934	1	466
D1015, D1016	1	40
D1034A, B, C	3	1410
D1042	1	45
D1048A, B, C, D	3	1410

Name & Model or Chassis No.	Vol. 5 Diag. No.	Previous Vols. Diag. No.
D1070	1	43
D1117	1	525
D1118	1	182
D1124	1	48
D1145	1	41
D1172, D1176	1	41
D1202	1	182
D1215	1	40
D1224	1	48
D1234A, B,		
D1240A	4	1755
D1435A,		
D1436A	2095	

D1612	2	591
D1644	1	189
D1645	1	38
D1747, D1748	2	588
D1752	2	798
D1835	2	1020
D1836, A	2	599
D1840	2	810
D1845	2	596
D1846A, B, C	2	599
D1949, D1950	2	1021
D1992 (Radio Ch.)	3	1411
D1994 (Radio Ch.)	3	1412
D2017, D2018	3	1413
D2020	3	1414
D2025A	3	1413
D2027A	3	1415
D2102A, B,		
D2103A, B	4	1756
D2127	1	182
D2133	1	526
D2145	4	1757
D2149	1	41
D2210, D2211	1	40
D2214A	4	1758
D2224	1	182
D2226	4	1759
D2237A	4	1760
D2261	1	48
D2263	4	1761
D2325-A	4	1762
D2383	4	1763
D2385	2096	
D2410A,		
D2411A,		
D2412A,		
D2413A	2097	
D2410B,		
D2411B,		
D2412B,		
D2413B	2098	
D2418A,		
D2419A,		
D2420A	2099	
D2483	2100	
D2553A	2101	
D2560A	2102	

D2610, D2611	1	527
D2612, D2613	1	20
D2615	1	529
D2616	1	528
D2616B	2	1022
D2619	2	1023
D2620	1	531
D2021	1	530
D2622	1	275
D2623	1	18
D2624	1	78
D2626	2	1024
D2630	1	78
D2634	1	125
D2640	2	1025
D2642	1	275
D2644	1	13
D2645	1	68
D2661	1	527
D2663	1	4
D2665	2	1026
D2692	2	1027
D2710	2	1028
D2718	2	1029
D2745	1	38
D2748	2	1030
D2810	2	1031
D2815	2	1022
D2819	2	1032
D2919	2	1033
D2963	3	1416
D-3120A	4	1764
D-3130A, B	4	1765
D3210A	4	1766
D3265A	4	1767
D3619	1	95
D3630, N	1	73

Name & Model or Chassis No.	Vol. 5 Diag. No.	Previous Vols. Vol. No. Diag. No.	Name & Model or Chassis No.	Vol. 5 Diag. No.	Previous Vols. Vol. No. Diag. No.	Name & Model or Chassis No.	Vol. 5 Diag. No.	Previous Vols. Vol. No. Diag. No.
<b>TRUETONE (Continued)</b>			<b>WELLS-GARDNER (Continued)</b>			<b>WESTINGHOUSE (Continued)</b>		
D3720	2	1034	1A17	1	46	H-33875U		
D3721	2	1035	1A29	1	45	H-34175U	4	1773
D3722	2	811	1A82 Series,			H-342P5U	4	1774
D3809, D3810	2	633	1A62-4	1	183	H-34575,	4	
D3840	2	1036	1A63 Series,			H-34675	4	1773
D4320, B,			1A63-3, 1A63-4	1	183	H-348P5,		
D4321, A	1881		5A25S	1	72	H-349P5	4	1774
D4425B,			6A43, 6A44	1	41	H-35077,		
D4426A,	1881		6A65 Series,			H-35177	4	1775
D4620	2	656	6B10, 6B16, 6B18	1	532	H-354C7	4	1776
D4818	2	580	7A52, 7A41	1	45	H-357C10	4	1777
D2093A	3	1417	7A66	1	526	H-35975,		
D21094A	3	1410	7D11 Series,	1	182	H-36075	4	1778
2D1194A			8A30, 8A31	1	45	H-36176	4	1779
(Radio Ch.)	4	1768	8A51 Series,	1	41	H-368P5,		
2D1315A	4	1769	321MS39-322,			H-369P5	4	1774
2D1316A	1829,		-372-2,			H-37077,		
	2103		-376-2	1834		H-37177	4	1780
2D1325A	4	1769	2321MS39-324,			H-38275,		
2D1326A	1829,		-370, -396-1	1834		H-38375	4	1781
	2103					H-38575,		
2D1331A, B,			<b>WESTINGHOUSE</b>			H-38675,		
2D1336A,	1834		H-104, A, H-105,			H-38775,		
2D1344A, B	4	1770	A, H-107, A, H-108,			H-38875	4	1782
2D1353A	2104		A, H-110, H-111	1	533	H-39175,		
2D1359A	2077		H-113, H-114,			H-39275	2106	
2D1415A,			H-116, H-117,			H-39376	4	1783
2D1416A,			H-119	1	535	H-39775,		
2D1426A	1829		H-122	1	534	H-39875	2107	
2D2312A	4	1769	H-125, H-126	1	536	H-400P4,		
2D2313A	1829,		H-130	1	534	H-401P4,		
	2103		H-133	1	539	H-402P4,		
2D2313C	1829		H-137, H-138	1	533	H-403P4	4	1784
2D2314A	4	1769	H-147	2	936	H-404P5,		
2D2315A	1829,		H-148, A	1	538	H-406P5	2108	
	2103		H-153, A	1	534	H-42075		
2D2321A	4	1769	H-154	1	533	H-42175	2106	
2D2334A	1834		H-155, H-156	1	534	H-442P4,		
2D2414A,			H-157	2	1040	H-423P4,		
2D2415A,			H-161	2	1041	H-424P4	2109	
2D2422A, B	1829		H-164	2	1042	H-425P4		
3D6000	1829		H-165	2	1043	H-43475,		
			H-166, H-167	2	1042	H-43575,		
			H-168, A, B	2	1041	H-43675,		
			H-169	2	1044	H-43775,		
			H-171, A, C	1	534	H-43875	2110	
			H-178	2	1045	H-44375,		
			H-182	2	1046	H-44475, A,		
			H-183, A	2	1047	H-44575, A,		
			H-185	2	1048	H-44675, A	2111	
			H-186M, H-187	2	1049	H-45776,		
			H-188	2	1037	H-45875,		
			H-190, H-191, A	2	1050	H-45975,		
			H-195	2	1048	H-46076	2112	
			H-198	3	1419	H-466R6,		
			H-202	2	1051	H-467R6,		
			H-203	3	1418	H-468R6	2112	
			H-204	2	1051	H-469R12,		
			H-207AM	3	1418	H-470R12	2113	
			H-207A (DX),			H-47575,		
			H-207B (DX)			H-47675,		
			(Radio Ch.)	3	1419	H-47775,		
			H-212	3	1418	H-47875	2114	
			H-214, A	3	1420	H-480C12	2113	
			H-217, A, B	3	1420	H-482PR5	2115	
			(Radio Ch.)	3	1419	H-48675,		
			H-220	2	1050	H-48775,		
			H-251	3	1432	H-48875,		
			H-300T5, H-301T5	3	1421	H-48975	2116	
			H-302P5	3	1422	H-600T16,		
			H-303P4, H-304P4	3	1423	H-601K12,		
			H-307T7, H308T7	3	1419	H-602K12	3	1430
			H-309P5, H-309P5U	3	1424	H-603C12	3	1431
			H-310T5, H-310T5U,			H-604T10, A	3	1432
			H-311T5, H-311T5U	3	1425	H-608C12	3	1431
			H-312P4, H-312P4U,			H-609T10	3	1432
			H-313P4, H-313P4U,			H-611C12,		
			H-314P4, H-314P4U,			H-615C12	3	1433
			H-315P4, H-315P4U	3	1426	H-633C17,		
			H-316C7, H-317C7	3	1427	H-634C17	3	1434
			H-318T5, U,			H-660C7,		
			H-320T5, U,			H-681C17		
			H-321T5, U,			(Radio Ch.)	4	1777
			H-322T5, U,			H-67717,		
			H-323T5, U	3	1428	H-68877,		
			H-324T7			H-673K21,		
			H-325T7, U,			H-676P31,		
			H-326C7	3	1427	H-678K17,		
			H-327T8U	3	1429	H-679K17,		
			H-328C7, U	4	1771	H-681T17,		
			H-331P4, U			H-688K24,		
			H-332P4	4	1772	H-689T16,		
			H-334T7U, UR,			H-690K21,		
			H-335T7U	4	1771	H-692T21,		
			H-336T7U	4	1771	H-695K21,		
			H-337T7U	4	1771	H-699A11		
			H-338T7U	4	1771			
			H-339T7U	4	1771			
			H-340T7U	4	1771			
			H-341T7U	4	1771			
			H-342T7U	4	1771			
			H-343T7U	4	1771			
			H-344T7U	4	1771			
			H-345T7U	4	1771			
			H-346T7U	4	1771			
			H-347T7U	4	1771			
			H-348T7U	4	1771			
			H-349T7U	4	1771			
			H-350T7U	4	1771			
			H-351T7U	4	1771			
			H-352T7U	4	1771			
			H-353T7U	4	1771			
			H-354T7U	4	1771			
			H-355T7U	4	1771			
			H-356T7U	4	1771			
			H-357T7U	4	1771			
			H-358T7U	4	1771			
			H-359T7U	4	1771			
			H-360T7U	4	1771			
			H-361T7U	4	1771			
			H-362T7U	4	1771			
			H-363T7U	4	1771			
			H-364T7U	4	1771			
			H-365T7U	4	1771			
			H-366T7U	4	1771			
			H-367T7U	4	1771			
			H-368T7U	4	1771			
			H-369T7U	4	1771			
			H-370T7U	4	1771			
			H-371T7U	4	1771			
			H-372T7U	4	1771			
			H-373T7U	4	1771			
			H-374T7U	4	1771			
			H-375T7U	4	1771			
			H-376T7U	4	1771			
			H-377T7U	4	1771			
			H-378T7U	4	1771			
			H-379T7U	4	1771			
			H-380T7U	4	1771			
			H-381T7U	4	1771			
			H-382T7U	4	1771			
			H-383T7U	4	1771			
			H-384T7U	4	1771			
			H-385T7U	4	1771			
			H-386T7U	4	1771			
			H-387T7U	4	1771			
			H-388T7U	4	1771			
			H-389T7U	4	1771			
			H-390T7U	4	1771			
			H-391T7U	4	1771			
			H-392T7U	4	1771			
			H-393T7U	4	1771			
			H-394T7U	4	1771			
			H-395T7U	4	1771			
			H-396T7U	4	1771			
			H-397T7U	4	1771			
			H-398T7U	4	1771			
			H-399T7U	4	1771			
			H-400T7U	4	1771			
			H-401T7U	4	1771			
			H-402T7U	4	1771			
			H-403T7U	4	1771			
			H-404T7U					



Name & Model or Chassis No.	Vol. 5 Diag. No.	Previous Vols. Vol. No. Diag. No.
--------------------------------	------------------------	---

Name & Model or Chassis No.	Vol. 5 Diag. No.	Previous Vols. Vol. No. Diag. No.
--------------------------------	------------------------	---

Name & Model or Chassis No.	Vol. 5 Diag. No.	Previous Vols. Vol. No. Diag. No.
--------------------------------	------------------------	---

**WESTINGHOUSE (Continued)**

H-700T17,		
H-701T17,		
H-701K21,		
H-702K17,		
H-703K17,		
H-704T17,		
H-705K17,		
H-710T21,		
H-711T21 (Ch.		
V-2217-2),		
H-713K21,		
H-714K21 (Ch.		
V-2217-2),		
H-715K21 (Ch.		
V-2217-2),		
H-720K21 (Ch.		
V-2217-2),		
H-721K21 (Ch.		
V-2217-2),		
H-722K21 (Ch.		
V-2217-2) .....	4	1785
H-730C21,		
H-732C21,		
H-733C21 .....	4	1786
H-1251 .....	1	536
WR-12X7 .....	1	537
WR-12X8 .....	1	411
WR-12X9,		
WR-12X12 .....	1	397
WR-12X14 .....	1	415
WR-12X15 .....	1	137
WR-12X16 .....	1	140
WR-13X8 .....	1	411
WR-42X3 .....	1	413
WR-42X4, -42X5		
WR-42X7 .....	1	437
WR-42X14,		
-42X15 .....	1	437
WR-42X42 .....	1	446
WR-158 .....	1	443
WR-158, A .....	1	540
WR-170, -172,		
-175, -176 .....	1	107
WR-186 .....	1	537
WR-258 .....	1	443
WR-260 .....	1	541
WR-264 .....	1	395
WR-270, WR-272		
WR-274 .....	1	107
WR-290 .....	1	102
WR-366, -368,		
-370 .....	1	420
WR-372, -373 .....	1	107
WR-374 .....	1	102
WR-388 .....	1	417
WR-473, -474 .....	1	107
WR-476 .....	1	102
WR-480, -482, -484		
WR-480 .....	1	537

**Chassis**

V-2102, -1 .....	1	533
V-2103 .....	1	534
V-2103-3 .....	3	1420
V-2107 .....	2	539
V-2118 .....	2	1041
V-2119-1 .....	2	1042
V-2120 .....	2	1043
V-2122 .....	2	1040
V-2123 .....	2	1045
V-2124-1 .....	2	1044
V-2127 .....	2	1047
V-2128, -1 .....	2	1046
V-2128-2 .....	2	1051
V-2130-21DX,		
22DX .....	3	1419
V-2131, -1 .....	3	1048
V-2132 .....	2	1049
V-2133 .....	2	1037
V-2134 .....	2	1050
V-2136 .....	3	1419
V-2136-1, -2 .....	3	1427
V-2136-4, -5R .....	4	1771
V2137 .....	3	1418
V-2137-2 .....	3	1419
V-2137-5U .....	4	1771
V-2148 .....	3	1421
V-2150-41 .....	3	1430
V-2150-61, A, B		
V-2150-81, -82,		
-84 .....	3	1432
V-2150-91A,		
-94, -94C .....	3	1432
V-2151-1 .....	3	1422
V-2152-01 .....	3	1431
V-2152-16 .....	3	1433

**WESTINGHOUSE (Continued)**

V-2153-1 .....	3	1426
V-2158 .....	3	1424
V-2158-1U .....	4	1774
V-2156-2 .....	2108	
V-2157, U, -1,		
-1U .....	3	1428
V-2157-2, -2U .....	3	1428
V-2157-3U .....	3	1429
V-2157-4U .....	4	1773
V-2157-6 .....	4	1778
V-2157-10 .....	4	1781
V-2157-11, -12 .....	4	1782
V-2157-13,		
-14 .....	2106	
V-2161, U .....	3	1425
V-2164-2 .....	4	1784
V-2173 .....	3	1434
V-2180-1 .....	4	1775
V-2180-2 .....	4	1776
V-2180-3, -5 .....	4	1777
V-2180-8 .....	4	1780
V-2180-9, -10 .....	4	1786
V-2181-13 .....	2113	
V-2182-2 .....	4	1779
V-2182-2 .....	4	1783
V-2184-2 .....	2107	
V-2188-1 .....	2109	
V-2189-2 .....	2110	
V-2189-4 .....	2111	
V-2214-1, .....	1	552
-2215-1, .....	1	552
V-2216-1, -2,		
-3, -4, -5, .....	1	552
V-2217-1, -2, -3,		
-4, -5 .....	4	1785
V-2218-1, -2,		
-11 .....	4	1786
V-2219-1 .....	4	1785
V-2229-1, .....	1	552
-2, -3 .....	1	552
V-2229-5 .....	2115	
V-2235-1 .....	2114	
V-2236-2 .....	2116	

**WOOLAROC**

3-1A, 3-2A .....	1	20
3-3A .....	1	25
3-4A .....	1	516
3-5A .....	2	574
3-6A/5 .....	2	1052
3-9A, 3-10A .....	1	385
3-11A .....	1	387
3-12A/3 .....	2	1053
3-17A, 3-18A .....	2	1054
3-20A .....	1	564
3-29A .....	1	388
3-70A .....	2	1055
3-71A .....	2	761
3-81A .....	2	1018

**ZENITH**

G500 .....	3	1435
G503 .....	3	1436
G510, G510Y .....	3	1437
G511, G511W, .....	3	1438
G511Y .....	3	1439
G516 .....	3	1439
G615, G615W, .....	3	1440
G615Y .....	3	1441
G660, G663, G665 .....	3	1442
G723, G724 .....	3	1443
G725 .....	3	1443
G881, G882, G883, .....	3	1444
G884, G885 .....	3	1444
G2322, G2340, R, .....	3	1445
G2346R, G2352E .....	3	1445
(Fine Tuning) .....	3	1445
G2322, G2340, R, .....	4	1807
G2346R, G2345E .....	4	1807
(Vol. Cont) .....	4	1807
G2420E, -EOX, .....	3	1445
-R, -ROX .....	3	1445
G2441, R, G2442E, .....	3	1445
R, G2448R (Fine .....	3	1445
Tuning) .....	3	1445
G2441, R, G2442E, .....	4	1807
R, G2448R (Vol. .....	3	1445
Cont) .....	4	1807
G2454R, -ROX .....	3	1445
G2951, R, OX, .....	3	1446
ROX, G2952, .....	3	1446
OX, ROX .....	3	1446
G2957, R, G2958R .....	3	1446
G2957, R, G2958R .....	4	1807
(Vol. Cont) .....	4	1807
G2957, R, G2958R .....	4	1807
(Radio Ch.) .....	3	1451
G3059R, G3062 .....	3	1445
(Fine Tuning) .....	3	1445
G3059R, G3062 .....	4	1807
(Vol. Cont) .....	4	1807
G3059R, G3062 .....	3	1451
(Radio Ch.) .....	4	1787
H-401, G .....	4	1787
H-500 .....	4	1788
H-503, Y .....	4	1787
H511, H511W, .....	3	1442
H511Y .....	4	1789
H-615 .....	4	1790
H-615Z1 .....	4	1790
H661E, H661R, .....	3	1447
H665, R, RZ, Z .....	4	1791
H-684 .....	3	1448
H723 .....	3	1449
H723Z .....	4	1792
H724 .....	3	1448
H-724Z, H-724Z1 .....	4	1792
H725 .....	3	1443
H880, H880R .....	3	1450
H880RZ .....	3	1451
H2029R, H2030E, .....	4	1793
H2030R, H2041R, .....	4	1793
H2052R, H2053E .....	4	1793
H2226E, R, .....	3	1452
H2227E, R, .....	3	1452
H2250R, H2255E .....	3	1452
H2328E, EZ, R, RZ, .....	3	1453
H2329R, RZ, .....	3	1453
H2330E, R, .....	3	1453
H2341R .....	3	1453
H2352R, RZ, .....	3	1453
H2353E, EZ, .....	3	1453
H2437E, R, .....	3	1454
H2438R, H2439R, .....	3	1454
H2443E, H2445R, .....	3	1454
H2447R, H2449E .....	3	1454
(TV Ch.) .....	3	1454
H3074 .....	4	1794
H3267, R, (TV Ch.) .....	3	1454
H3267R, (Radio Ch.) .....	3	1451
H3273E, H3274R, .....	4	1794
H3284R .....	3	1454
H3467R (TV Ch.) .....	3	1455
H3467R (Radio Ch.) .....	3	1455
H3469E (TV Ch.) .....	3	1454
H3469E (Radio Ch.) .....	3	1455
H3475R (TV Ch.) .....	3	1455
H3475R (Radio Ch.) .....	3	1454
H3477R (TV Ch.) .....	3	1455
H3477R (Radio Ch.) .....	3	1455
H3478E (TV Ch.) .....	3	1454
H3478E (Radio Ch.) .....	3	1455
H3490EQ .....	4	1794
HFM1184E, .....	2117	
HFM1190R .....	2117	
HFR1283E, .....	2118	
HFR1286R, .....	2118	
HFR1290R .....	2118	
J402 .....	4	1795
J420T .....	4	1796
J514 .....	4	1797
J615, F, G, W, Y .....	4	1798
J616 .....	4	1797
J644, J665E, R .....	4	1800
J733, G, R, Y .....	4	1801
J880, J880R .....	4	1801
J1063E, EZ, .....	4	1799
J1068R, Z, .....	4	1799
J1087, Z, .....	4	1794
J2025R, J2027E, .....	4	1794
R, J2029E, R, .....	4	1794
J2030E, R, .....	4	1794
J2031R, J2032R, .....	4	1794
J2040E, J2042R, .....	4	1794
J2043R, J2044E, .....	4	1794
R, J2049R, .....	4	1794
J2050R, J2051E, .....	4	1794
J2053R, J2054R, .....	4	1794
J2055R, J2126R, .....	4	1794
J2127E, R, .....	4	1794
J2129E, R, .....	4	1794
J2130E, R, .....	4	1794
J2140E, J2142R, .....	4	1794
J2143R, J2144E, .....	4	1794
R, J2151E, .....	4	1794
J2153R, J2154R, .....	4	1794
J2155R .....	4	1793
J2868R, J2968R .....	4	1793

Name & Model or Chassis No.	Vol. 5 Diag. No.	Previous Vols. Vol. No. Diag. No.
<b>ZENITH (Continued)</b>		
J3069E, J3169E	4	1793, 1794
K510, W, Y	4	1802
K515, K518	4	1797
K526, W, Y	4	1803
K622, F, G, W	4	1797
K668 R	4	1804
K725, F, G	4	1803
K777E, R	4	1805
K1812E, -3,		
K1812R,		
K1812R-3,		
K1815E, R,		
K1820E, R,		
K1846E, R,		
K1850E, R,		
K1880R, K2229E,		
K2229E-3,		
K2229R, -3,		
K2230E, R,		
K2235E, R,		
K2240E, R,		
K2258E, R,	4	1806
K2260R-3	2119	
K2262R, K2263E	4	1806
K2263E-3	2119	
K2266R	4	1806
K2266R-3	2119	
K2267E	4	1806
K2267E-3	2119	
K2268R,		
K2270H, R,		
K2271H	4	1806
K2271H-3	2119	
K2286R	4	1806
K2286R-3		
(TV Ch.)	2119	
K2287R	4	1806, 1801
K2287R-3		
(TV Ch.)	2119	
K2287R-3 (Radio Ch.)	4	1801
K2288E	4	1806
K2290R, K2291E	4	1806, 1794
K2291E-3		
(TV Ch.)	2119	
K2291E-3 (Radio Ch.)	4	1794
K2872R, K2873E	4	1806
L408R	2120	
L505F, R, Y	2121	
L507	2122	
L515, L518,		
F, G, W, Y,		
L520	2123	
L565E, R	2124	
L566	2125	
L600	2126	
L622, F,		
G, W	2123	
L677E, R	2127	
L721	2128	
L845R,		
L846E, H	2129	
L800	2130	
L1083E,		
L1088R	2131	
L1812E, R,		
L1820E, R,		
L1846E, EU,		
R, RU	2119	
L2229E, R,		
L2235E, R,		
L2236E, EU,		
R, RU, L2258E,		
EU, R, RU,		
L2259E, EU,		
R, RU, L2260R,		
RU, L2261E,		
EU, H, HU,		
L2262C, CU,		
R, RU, L2266R,		
RU, L2267E,		
EU, H, HU,		
L2270, U	2119	
L2281E,		
EU, R,		
RU, U	2119, 2117	
L2285R, RU		
(TV Ch.)	2119, 2130	
L2287R, RU,		
L2291E, EU	2119	

Name & Model or Chassis No.	Vol. 5 Diag. No.	Previous Vols. Vol. No. Diag. No.
<b>ZENITH (Continued)</b>		
L2571R, RU,		
L2572R, RU,		
L2573E, RU,		
L2574R, RU,		
L2575E, RU	2119	
L2582R, RU,		
L2593H, HU	2119, 2132	
L2876E, EU,		
R, RU,		
L2278R, U,		
L2879E, EU	2119	
L2894H, HU	2119, 2132	
M1800E, EU,		
EZ, R, RU,		
RZ	2133	
M2228R, RU,		
RZ, M2229E,		
EU, EZ, R,		
RU, RZ,		
M2230E, EU,		
EZ, R, RU,	2133	
RZ, RZ		
M2237EU,		
EZ, R,		
RU, RZ	2119	
M2249E, EU,		
EZ, R, RU,		
RZ, M2250E,		
EU, EZ, H,		
RU, RUZ,		
RZ, M2252E,		
EU, EZ, R.		
RU, RZ	2133	
M2260R, RU,		
RUZ, RZ,		
M2261E, EU,		
EZ, M2267YU,		
YZ	2119	
M2570R, RU,		
RUZ, RZ	2119	
R623F, G,		
R, W, Y	2131	
R1800E, EU,		
R, RU	2134	
R1800EUZ,		
EZ, RUZ, RZ	2133	
R1812E, RU,	2134	
R, RU	2134	
R1812EUZ,		
EZ, RUZ, RZ	2133	
R2229E, EU,		
R, RU	2134	
R2229EUZ,		
EZ, RUZ, RZ	2133	
R2230E, EU,		
R, RU	2134	
R2230EUZ,		
EZ, RUZ, RZ	2133	
R2249E, EU,		
R, RU	2134	
R2249EUZ,		
EZ, RUZ, RZ	2133	
R2250E, EU,		
R, RU	2134	
R2250EUZ,		
EZ, RUZ, RZ	2133	
R2253M, MU,		
R2257E, EU,		
R, RU	2134	
R2257EUZ,		
EZ, RUZ, RZ	2133	
R2258E, EU,		
R, RU	2134	
R2258EUZ,		
EZ, RUZ, RZ	2133	
T825F, G, R	2135	
4G903, 4G903Y	3	1456
4K016, 4K035	1	542
5D011, 5D027	1	544
5D010	2	555
5G003	1	544
5G003Z, ZZ	2	1056
5G036	2	1057
5R080, 5R086	1	544
6D014, W	1	542
6D015, Y	1	544
6D029, G	1	542
6D030	1	544
6D815, W, Y	2	1058
6G001, Y	1	544
6G004Y	1	543
6G038	2	555
6G050, 6G055	2	1059
6MPS90, 6MPS91	1	548

Name & Model or Chassis No.	Vol. 5 Diag. No.	Previous Vols. Vol. No. Diag. No.
<b>ZENITH (Continued)</b>		
6MN495, 6MN496	1	547
6MN595	1	546
6R084	1	549
6R087	1	542
6R806	2	1058
7H820, W	2	1060
7H822, WZ, Z	2	555
7H918	3	1457
7H920, W	3	1443
7H921, 7H922	3	1442
7ML592	1	550
7MN596	1	546
7R887	2	1061
8G005Y	1	542
8G005YT(21),		
(22)	2	1057
8H023	1	551
8H032, 8H033	1	551
8H034	1	551
8H050, 8H051,		
8H052, 8H061	1	552
8H832, 8H861	2	1062
9H079, E, R,		
9H082R, 9H885R,		
9H088R	1	542
9H881, 9H882R,		
9H885, 9H888R	2	1062
9H995	3	1458
12H090, 12H091,		
12H092, 12H093,		
12H094	1	35
14H789	2	1063
28T964R (Radio Ch.)	3	1437
37T996RLP		
(Radio Ch.)	3	1458
37T998RLPU		
(Radio Ch.)	3	1458
42T998RLP		
(Radio Ch.)	3	1437
<b>Chassis</b>		
4C52, 4C53	1	542
4F40	3	1456
4H40	4	1787
4J40	4	1795
4J60T	4	1796
4L03	2130	
4L42	2120	
5C01, Z, 5C02,		
Z, 5C04, 5C40	1	544
5C40Z, ZZ	2	1056
5C51	2	1057
5E02	2	555
5G01	3	1438
5G02	3	1437
5G03	3	1439
5G40	3	1435
5G41	3	1436
5H01	3	1442
5H40	4	1789
5H41	4	1787
5J03	4	1794
5K02	4	1802
5K03	4	1797
5K04	4	1803
5L03, 5L06,		
5L07	2123	
5L08	2125	
5L09	2124	
5L41	2121	
5L42	2122	
6C01	1	542
6C05, Z	1	544
6C21	1	549
6C22	1	542
6C40	1	544
6C41	1	543
6C50	2	555
6E02, 6E05	2	1058
6E40	2	1059
6G01	3	1441
6G05	3	1440
6G05Z1	4	1790
6G20	3	1451
6H01	3	1447
6H02	4	1791
6J02	4	1799
6J03	4	1797
6J05	4	1798
6K02	4	1804
6K03	4	1797
6L03	2123	
6L20	2127	
6L40	2126	
6R03	2131	

Name & Model or Chassis No.	Vol. 5		Previous Vols.	
	Diag. No.	Vol. No.	Diag. No.	Vol. No.
ZENITH (Continued)				
7E02, Z	2	555		
7E22	2	1061		
7F01	3	1443		
7F02	3	1442		
7F03	3	1457		
7F04	3	1442		
7G01, Z	3	1443		
7G02	3	1442		
7G04	3	1442		
7H02	3	1448		
7H02Z, 7H02Z1	4	1792		
7H04	3	1448		
7H04Z	3	1449		
7H04Z2	4	1792		
7J03	4	1800		
7K01	4	1803		
7K20	4	1805		
7L05	2128			
8C01	1	551		
8C20	1	552		
8C21	1	542		
8C40	1	542		
8C40T (Z1),				
(Z2)	2	1057		
8E20	2	1062		
8G20	3	1444		

Name & Model or Chassis No.	Vol. 5		Previous Vols.	
	Diag. No.	Vol. No.	Diag. No.	Vol. No.
ZENITH (Continued)				
8H20	3	1451		
8H20 Revised	3	1450		
8H20Z	4	1801		
8L20	2130			
8L21	2129			
8T01	2135			
9E21	2	1062		
9E21 Z	3	1458		
10H20Z	4	1794		
10L20	2130			
11C21	1	35		
11M20	2117			
12R20				
12R21	2118			
13D22				
19K20, 19K22, -3,	2	1063		
19K23, 19K24-3	4	1806		
19L25, 19L26,				
19L27, 19L28	2119			
19M20, U, Z,				
19M21, U,				
U, Z, Z	2133			
19R20, U,				
19R21, U,				
19R22, U	1934			
20H20, 20J21,				
20J22	4	1793		

Name & Model or Chassis No.	Vol. 5		Previous Vols.	
	Diag. No.	Vol. No.	Diag. No.	Vol. No.
ZENITH (Continued)				
20M20, U, Z,				
20M21, U,				
U, Z	2119			
21J20, 21J21	4	1793		
21K20	4	1806		
21K20-3	2119			
21L21	2119			
22H20	3	1452		
22L20	2119			
23G22, 23G23				
(Fine Tuning)	3	1445		
23G22, 23G23				
(Vol. Cont)	4	1807		
23H22, Z	3	1453		
24G20, -OX	3	1445		
24G21, -OX	3	1445		
24G22, 24G23,				
24G24, 24G25				
(Fine Tuning)	3	1445		
24G22, 24G23,				
24G24, 24G25				
(Vol. Cont)	4	1807		
24H20	3	1454		
28K20	4	1806		
29G20	3	1446		

TUNING GANG FULLY CLOSED

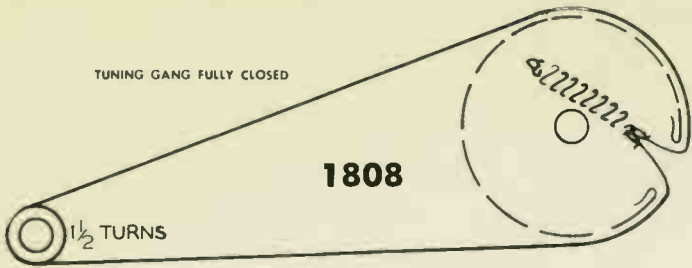

1808

2 1/2 TURNS



1809

TUNING GANG FULLY OPEN

TUNING GANG FULLY CLOSED

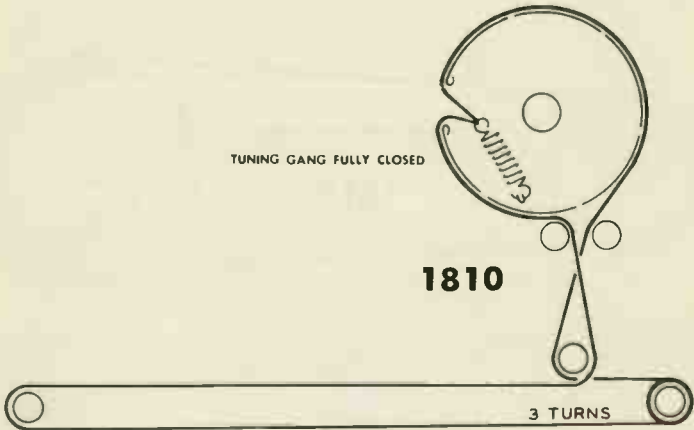

1810

3 TURNS

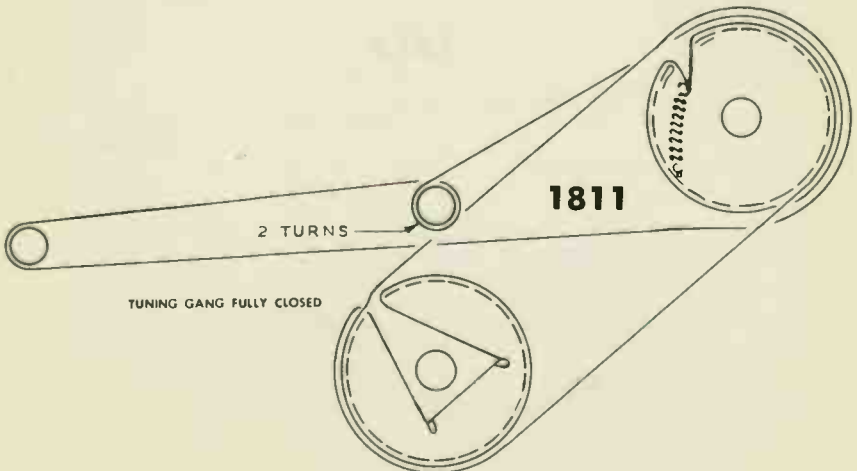

2 TURNS

1811

TUNING GANG FULLY CLOSED

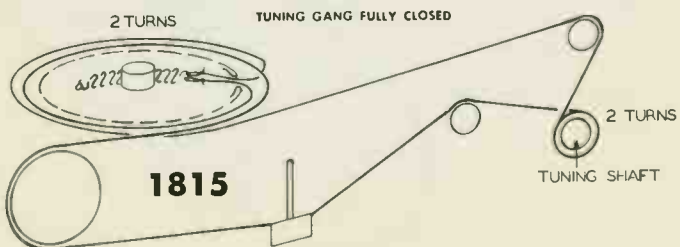
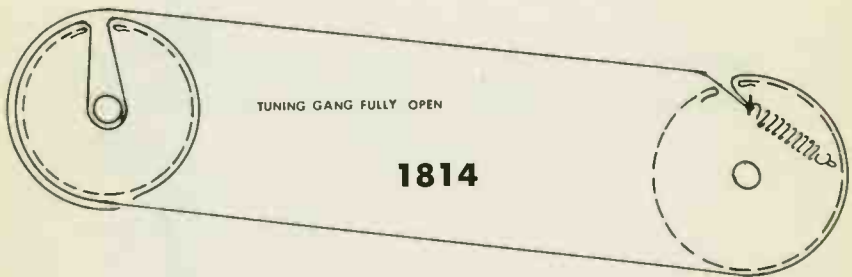
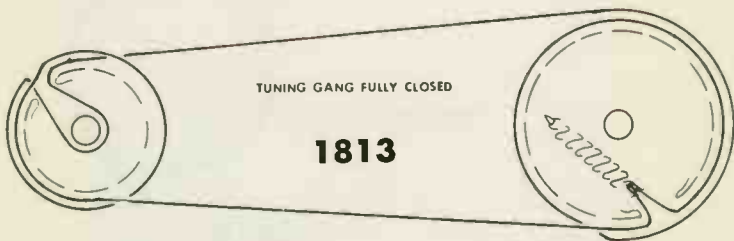
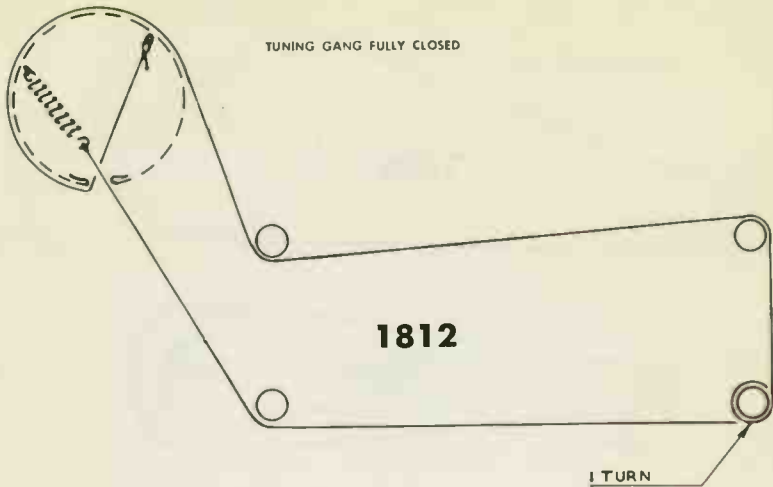

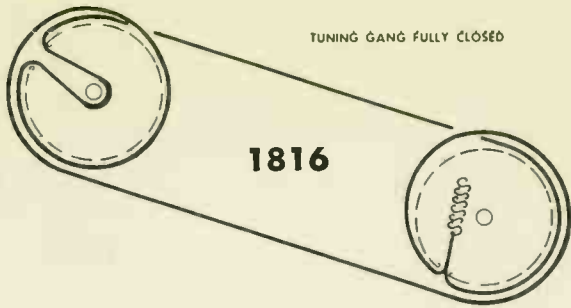

TUNING GANG FULLY CLOSED

**1816**

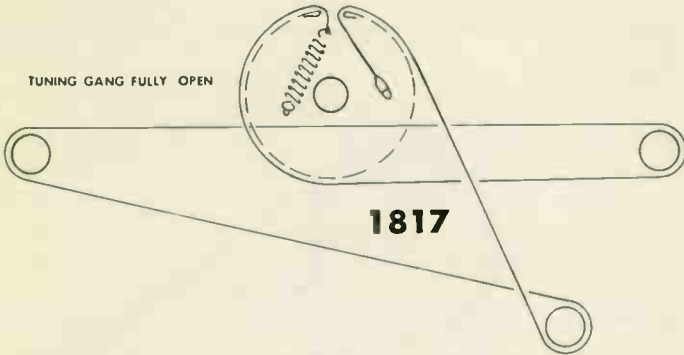

TUNING GANG FULLY OPEN

**1817**

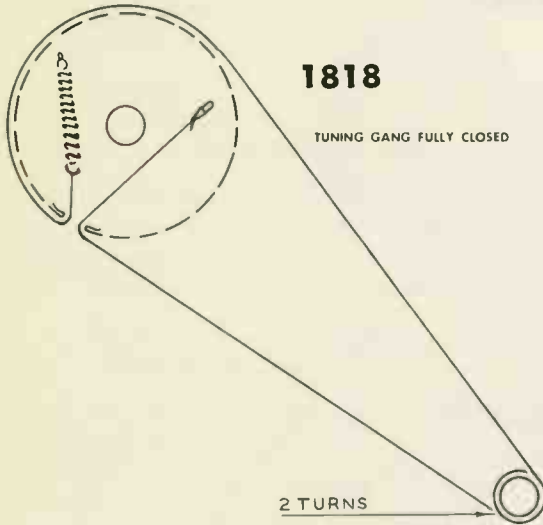

**1818**

TUNING GANG FULLY CLOSED

2 TURNS

TUNING GANG FULLY CLOSED



**1819**

1/2 TURNS  
TUNING HUB

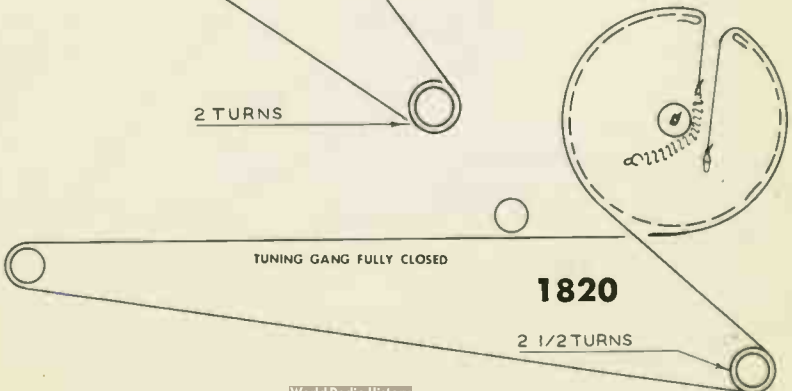

TUNING GANG FULLY CLOSED

**1820**

2 1/2 TURNS

TUNING GANG FULLY CLOSED

1821

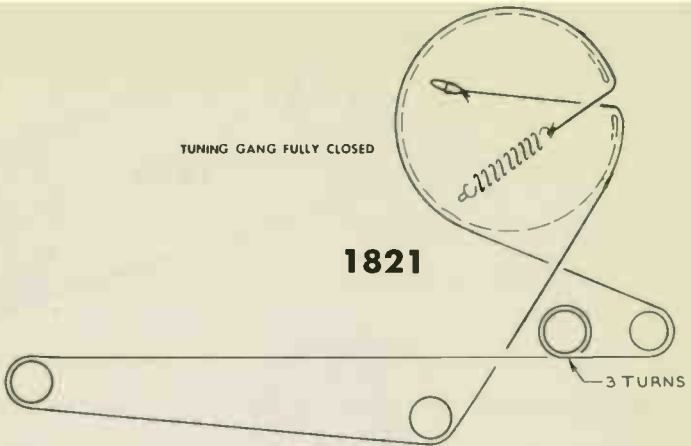

#1-STATION TUNING

#2-DIAL POINTER

TUNING GANG FULLY CLOSED

1822

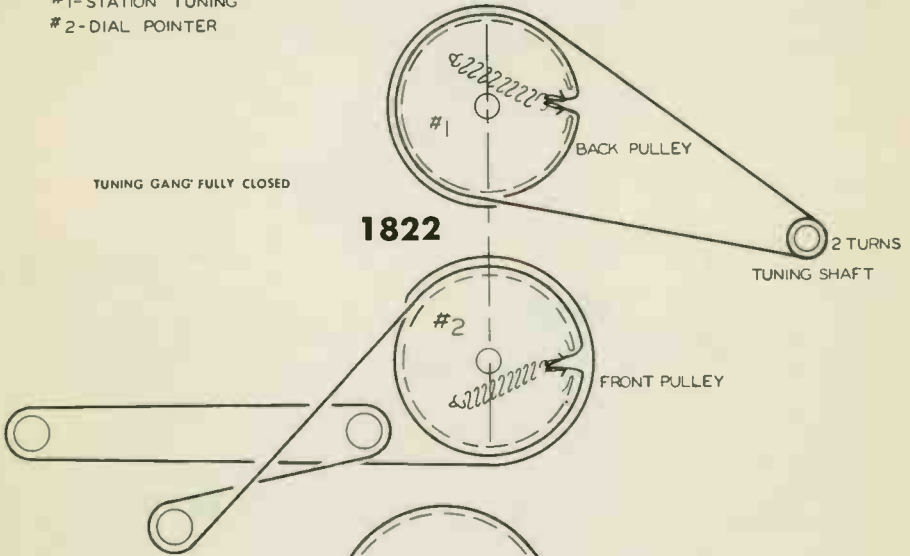

TUNING GANG FULLY CLOSED

1823

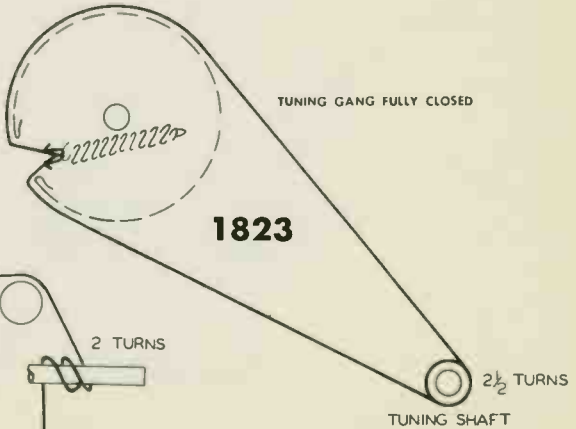

TUNING GANG FULLY CLOSED

1824

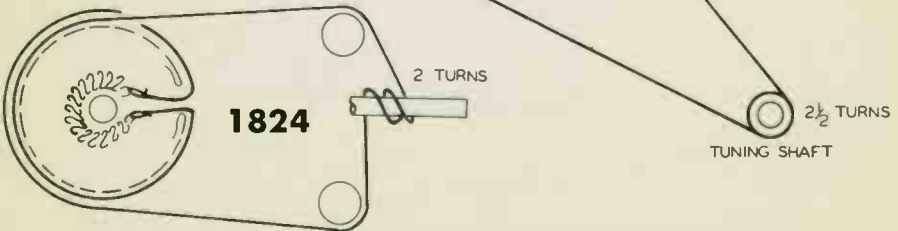

TUNING GANG FULLY CLOSED

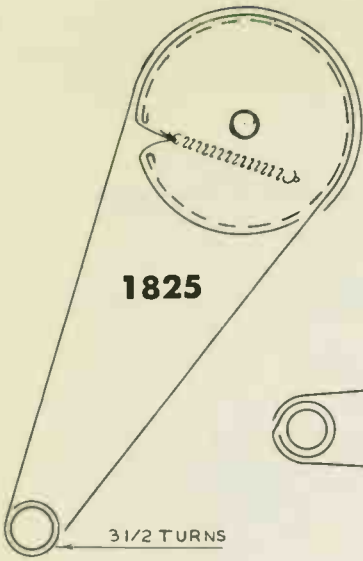

TUNING GANG FULLY CLOSED

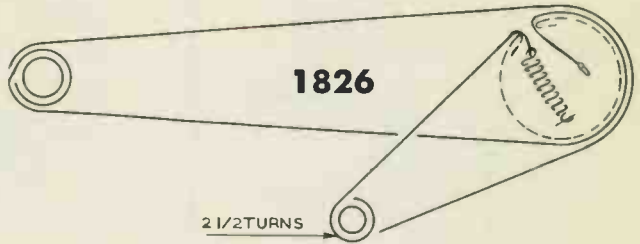

TUNING SHAFT FULLY CLOCKWISE



2 TURNS

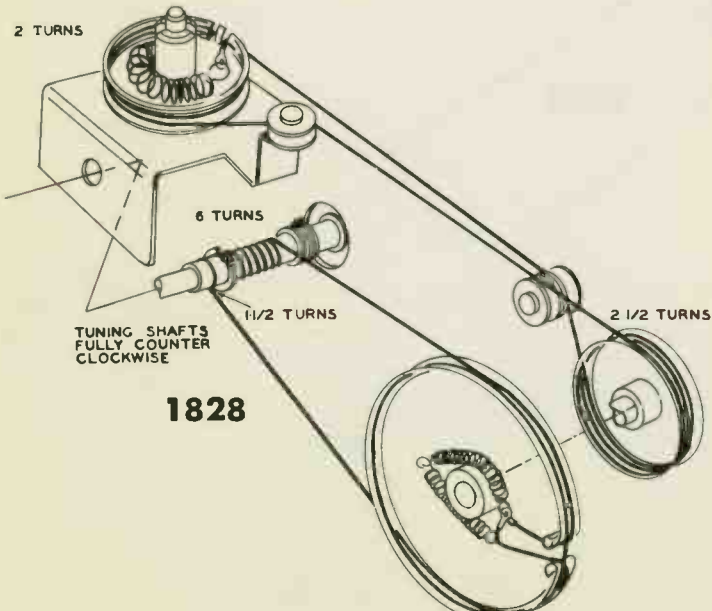



If for any reason the drive cord of either the RF or oscillator cavities need replacement, the exact cord and length are recommended. The cord used is of a special material which is not affected by temperature or moisture. Refer to the parts list for the correct replacement. The oscillator drive assembly consists of four (4) separate drive cords each locked to the oscillator drive pulley (Fig. 1) Each RF drive assembly consists of two (2) separate drive cords which are locked to the RF cavity drive pulley (Fig. 2) If the drive cord requires replacement, the picture tube should be removed along with the cavity cover. Follow the diagram and replace the cord as indicated. After replacement follow the instruction for realignment.

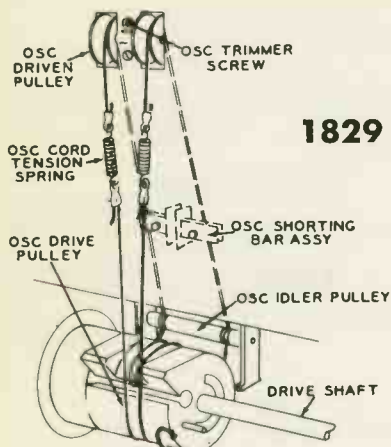

FIG. 1

**1829**

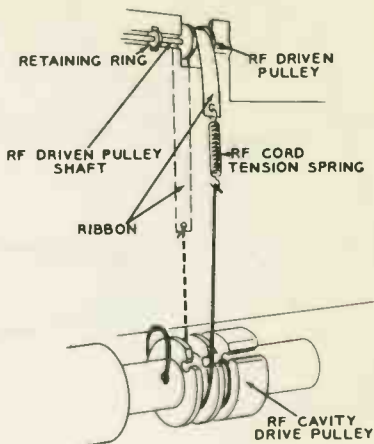
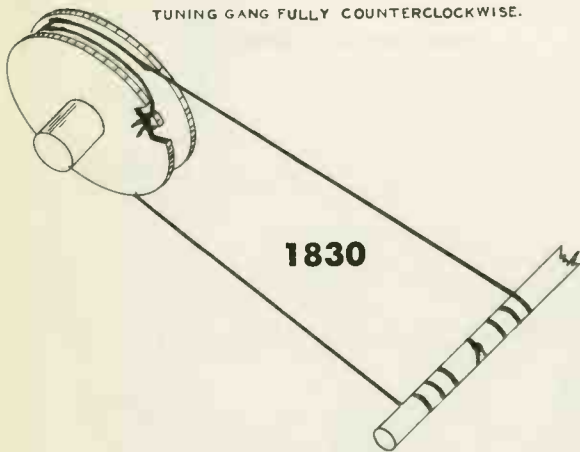
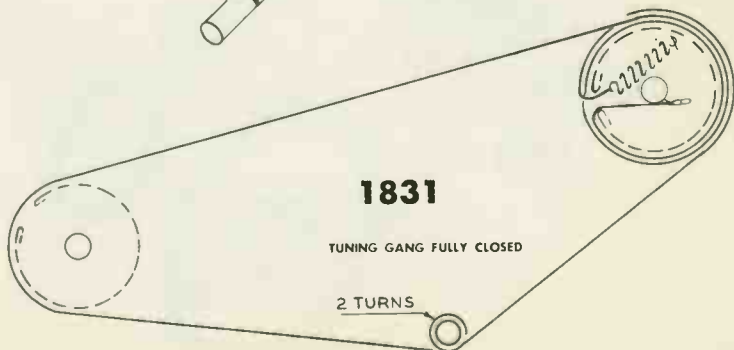

FIG. 2

TUNING GANG FULLY COUNTERCLOCKWISE.



**1830**



**1831**

TUNING GANG FULLY CLOSED

2 TURNS

TUNING GANG FULLY CLOSED

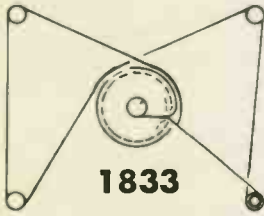
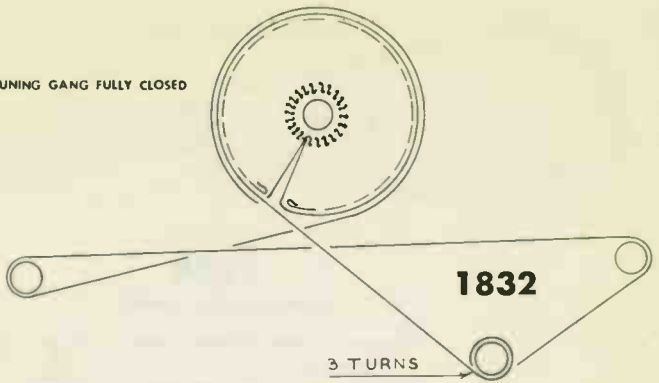

TUNING GANG FULLY CLOSED

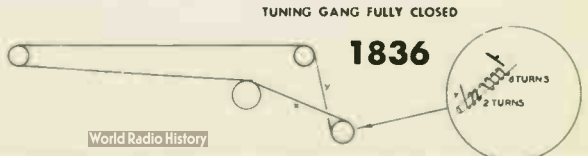
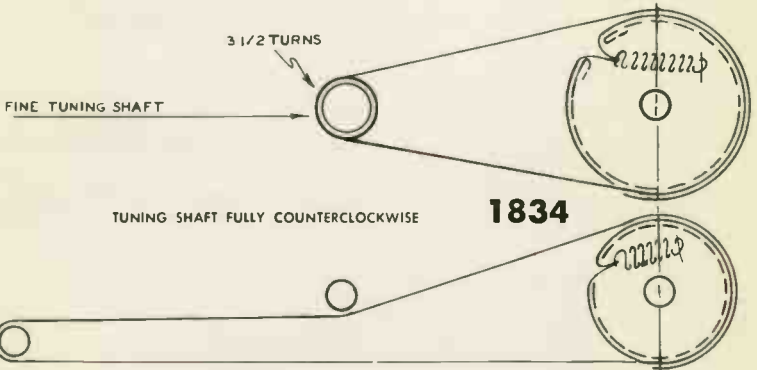

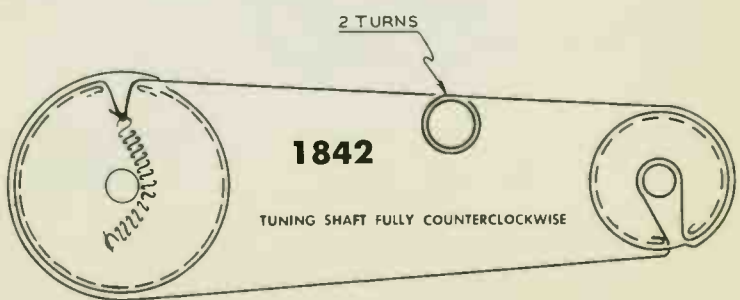
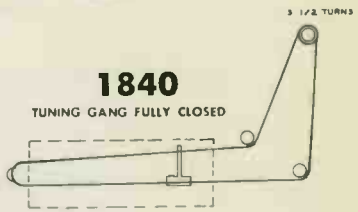
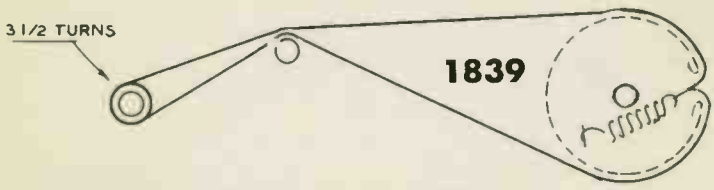

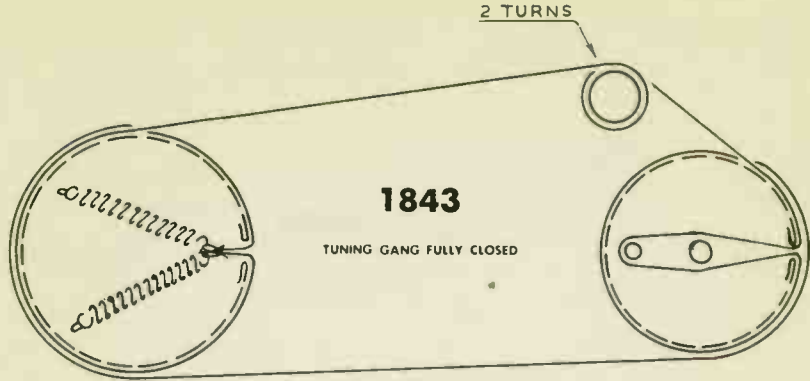

FINE TUNING IN MAX. COUNTER-CLOCKWISE POSITION.

UHF TUNING IN MAX. COUNTER-CLOCKWISE POSITION.

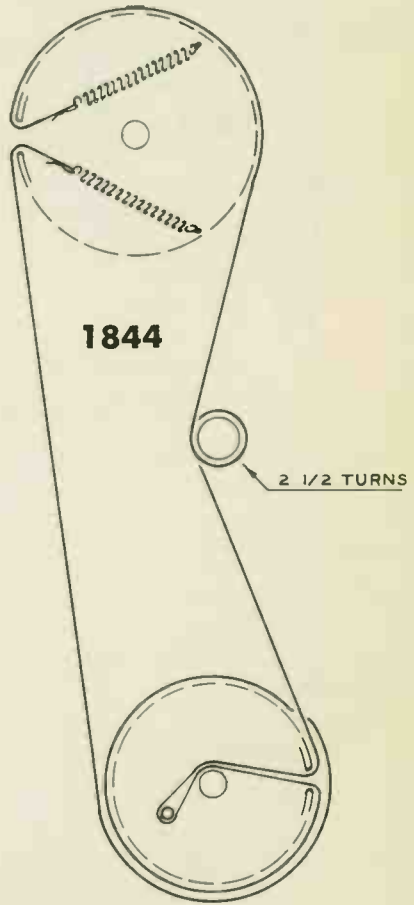

TUNING GANG FULLY CLOSED

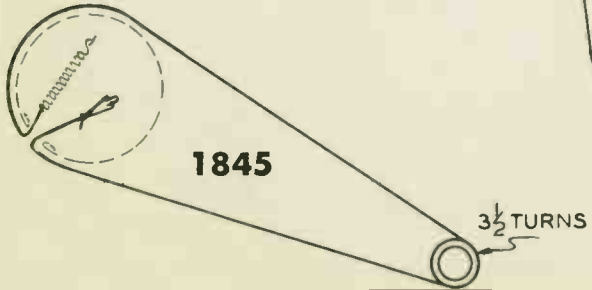

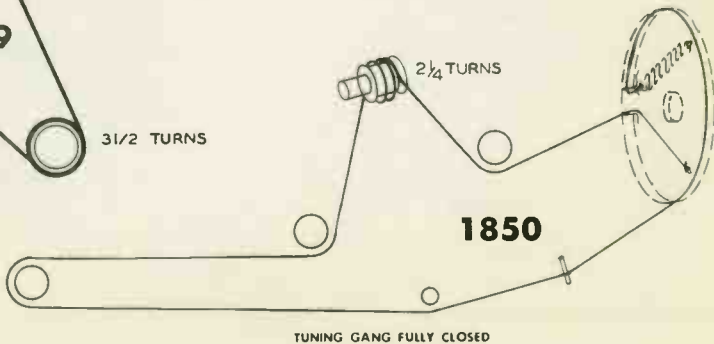
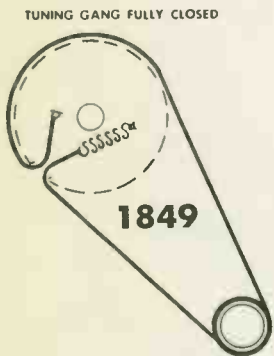
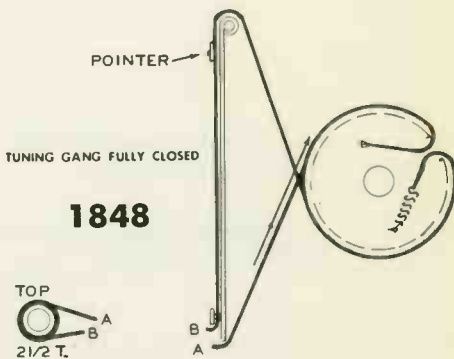
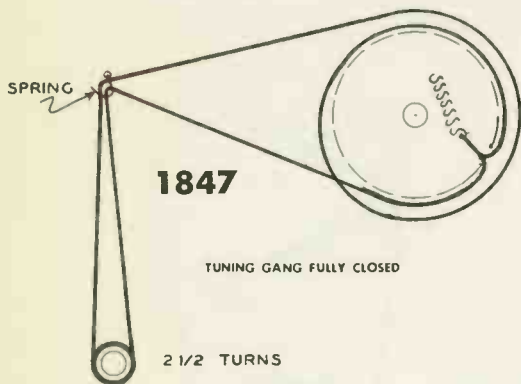
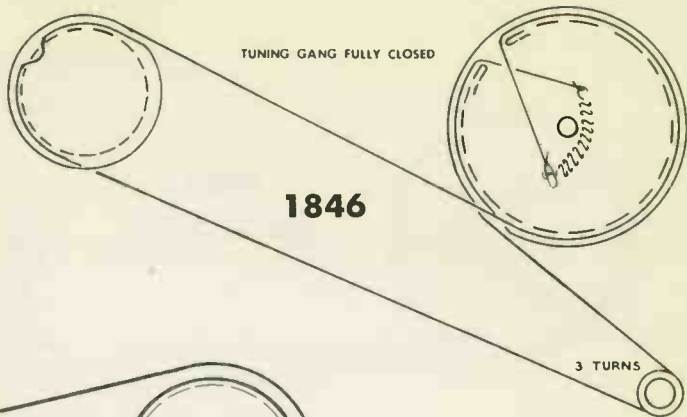

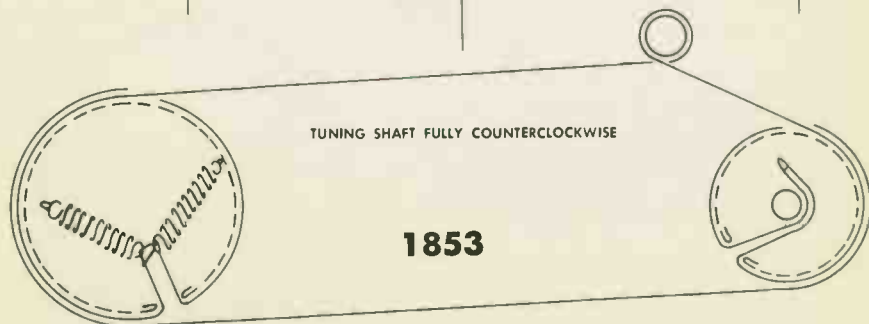
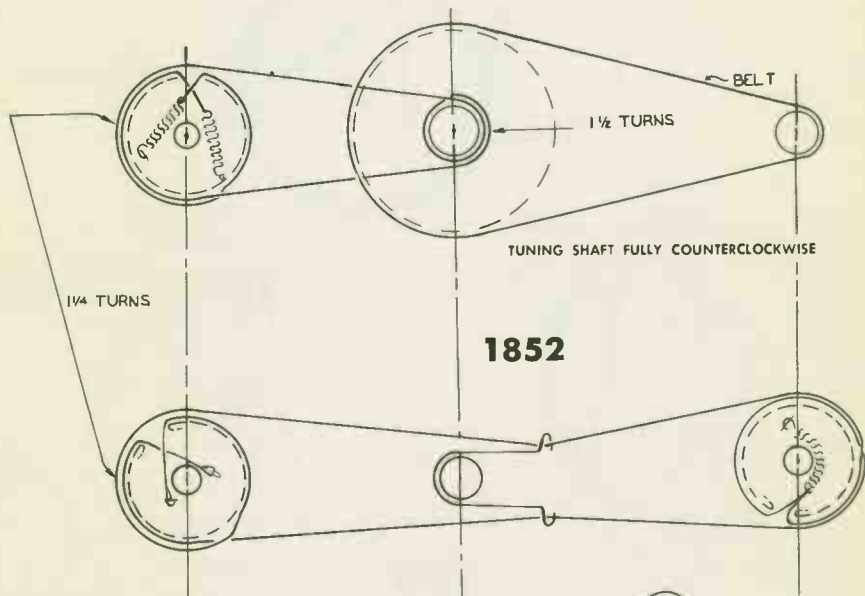
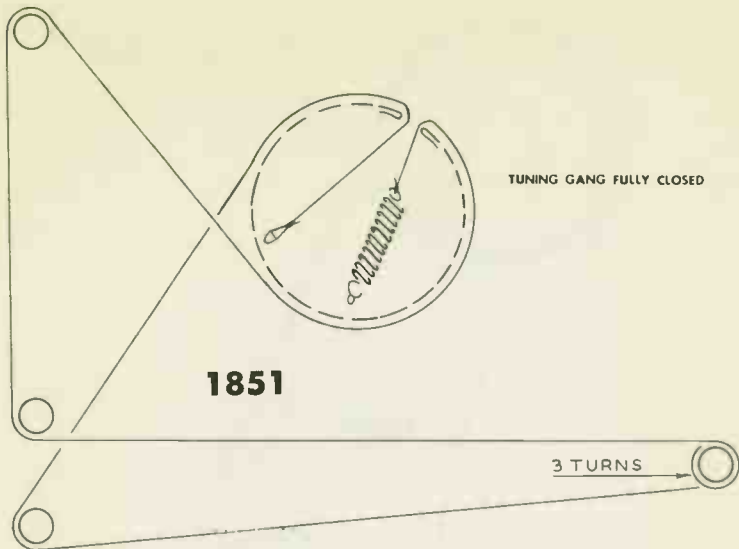

TUNER SET WITH PULLEY CUTOUTS FACING EACH OTHER

3 1/2 TURNS  
TUNING SHAFT-REAR

1854

CONVERTER TUNER

REAR  
2 1/2 TURNS  
2 3/4 TURNS  
FRONT

START

4° ± 2°  
VERTICAL

REAR - 2 1/2  
TURNS ON  
SMALL PULLEY.

1 TURN

1855

VERTICAL f  
45°  
APPROX.

THIS ANGLE MUST BE HELD TO PERMIT COVERAGE OF ENTIRE TUNING RANGE

WITH BOTTOM PULLEY IN FULL COUNTER-CLOCKWISE POSITION & OTHER PULLEYS IN POSITION SHOWN. WIND DIAL CORD AS INDICATED. ALL SPRINGS MUST BE UNDER TENSION.

REAR

FRONT

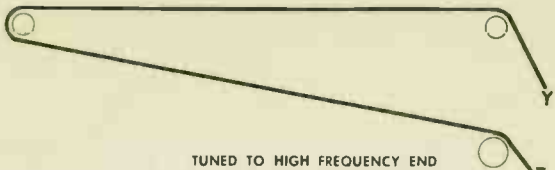

TUNED TO HIGH FREQUENCY END

**1856**

8 TURNS

2 TURNS

TUNING SHAFT

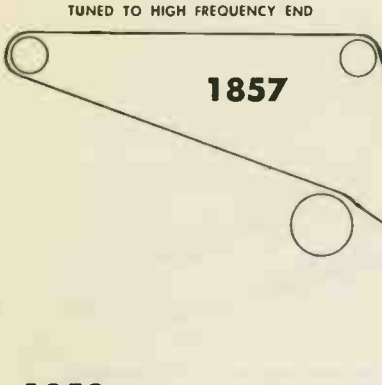

TUNED TO HIGH FREQUENCY END

**1857**

8 TURNS

2 TURNS

**1858**

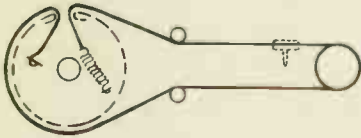

TUNING GANG FULLY OPEN



**1859**

DIAL CORD STRINGING FOR ALL CONTROLS.

DIALS FULLY CLOCKWISE



TUNING GANG FULLY OPEN

**1860**

1 1/2 TURNS



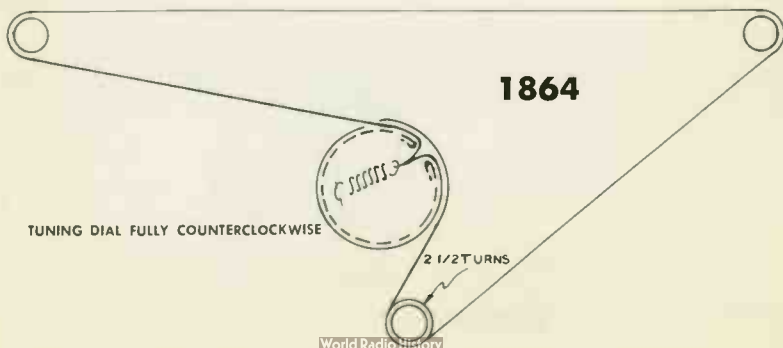
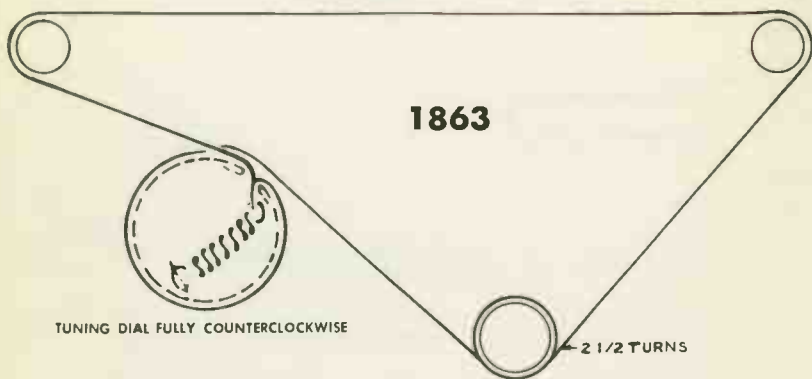
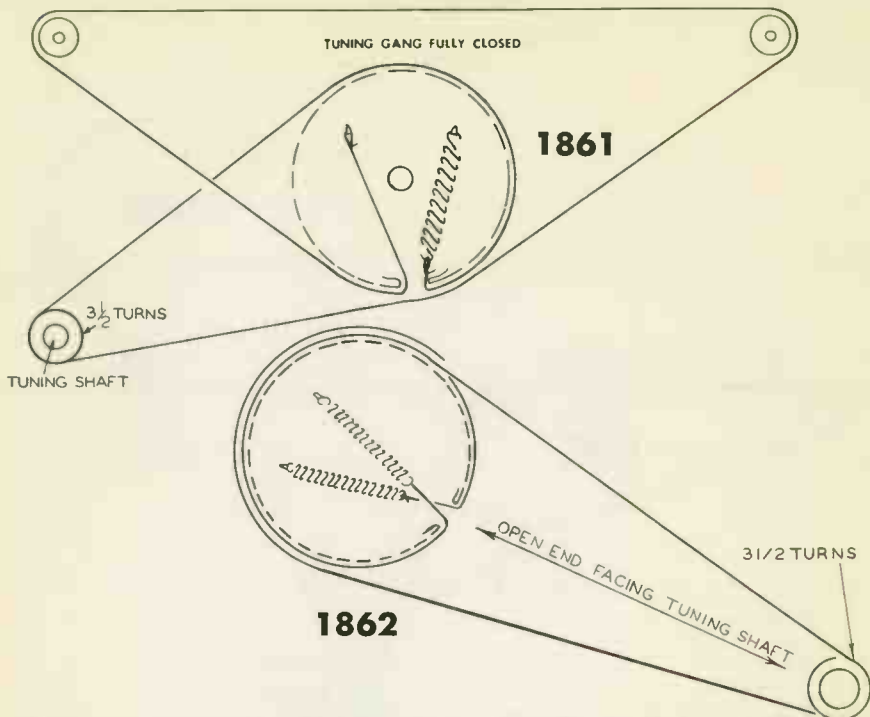

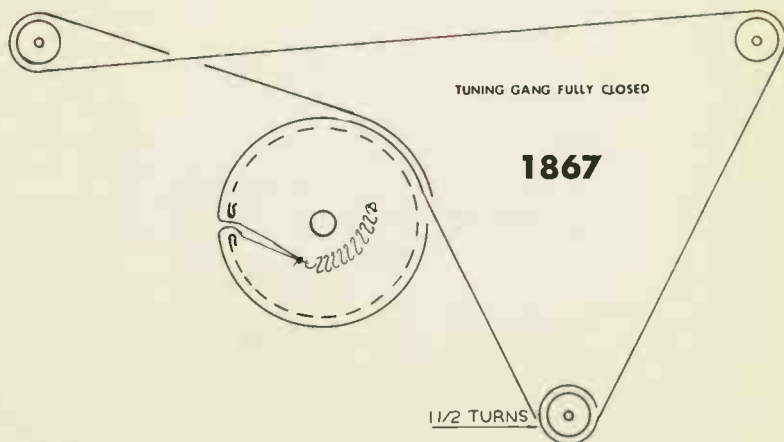
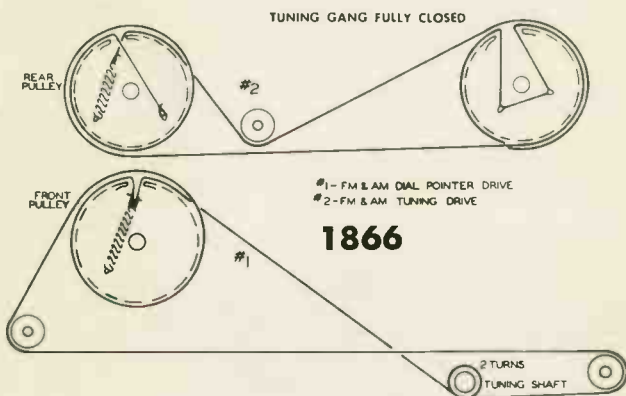
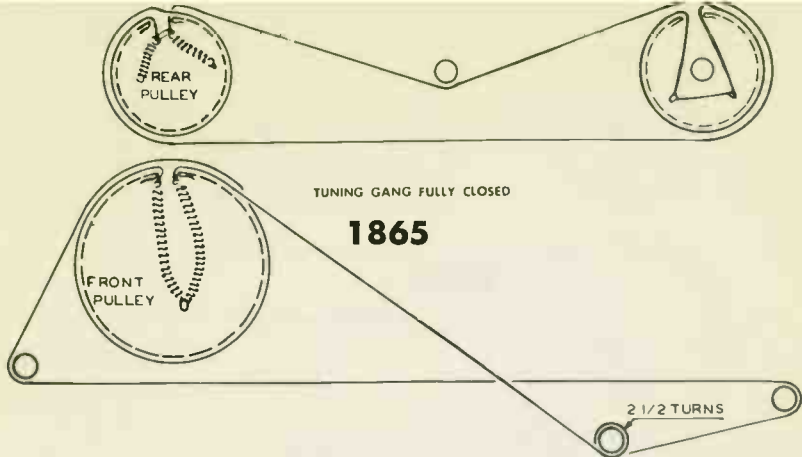

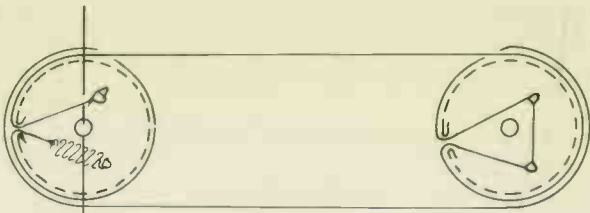

**1868**

TUNING GANG FULLY CLOSED

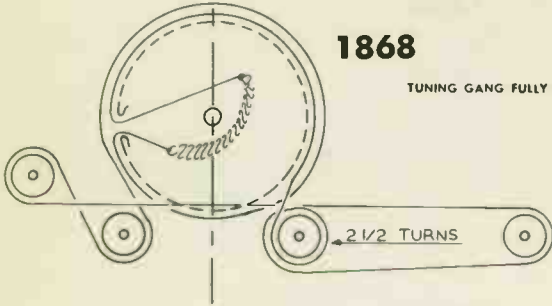

TUNING GANG FULLY CLOSED

**1869**

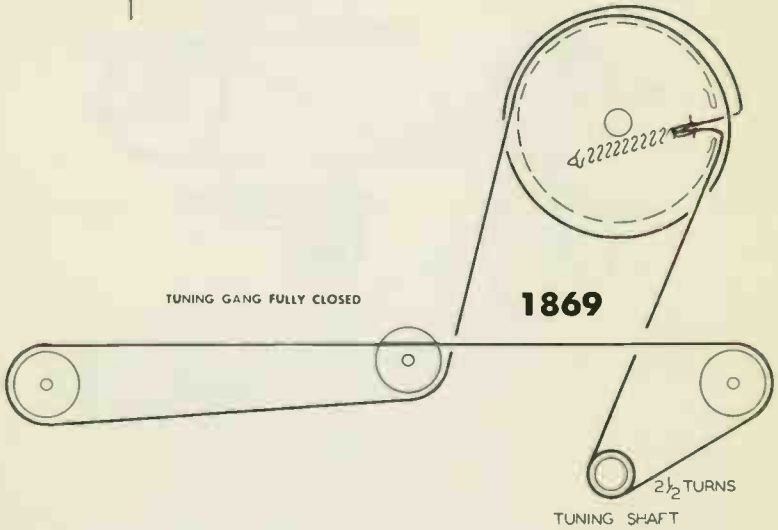

TUNING GANG FULLY CLOSED

2 1/2 TURNS

**1870**

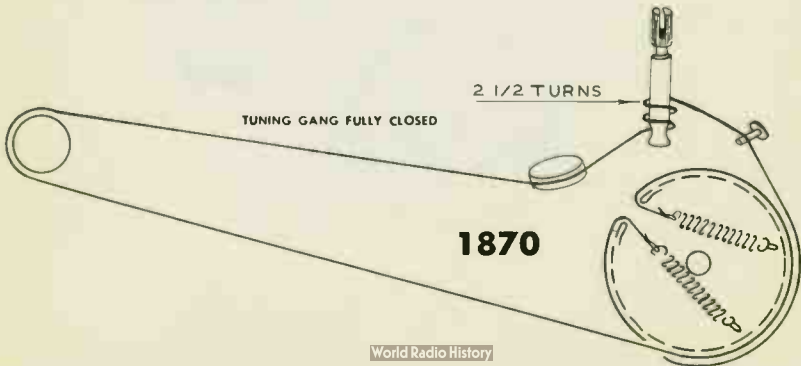

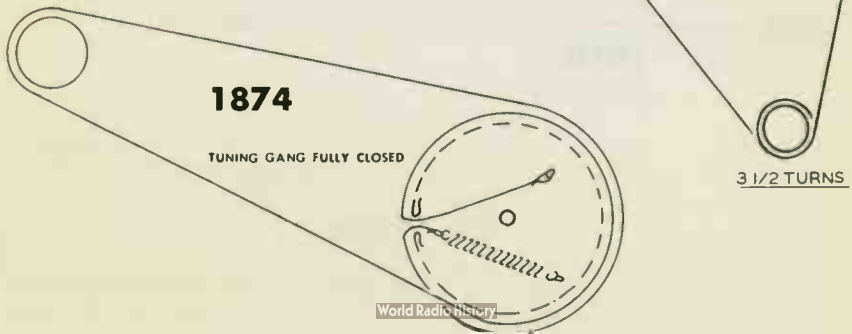
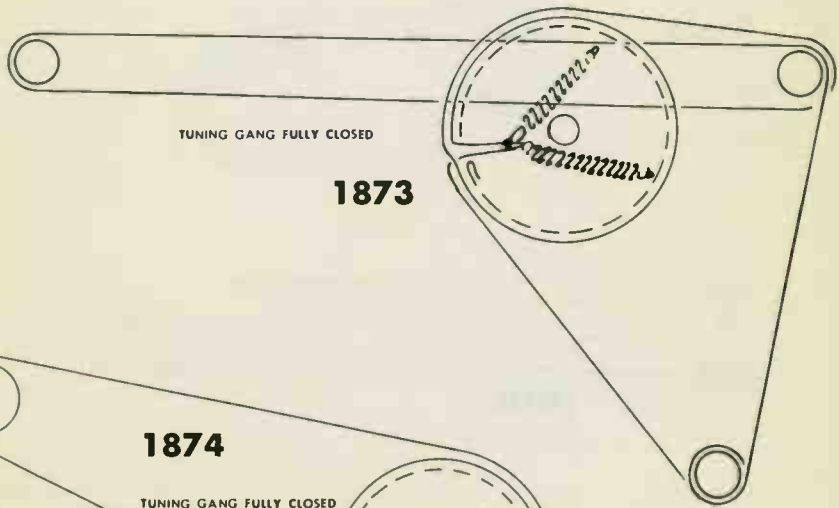
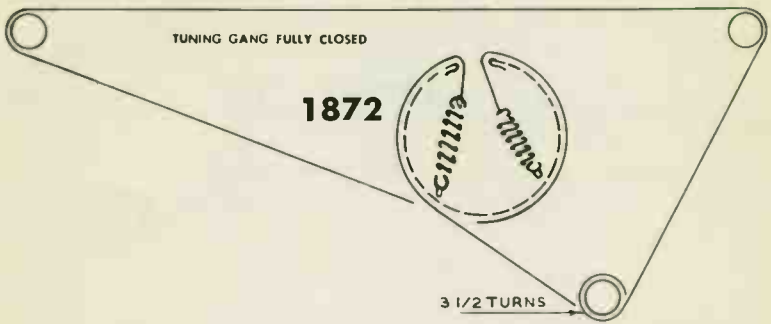
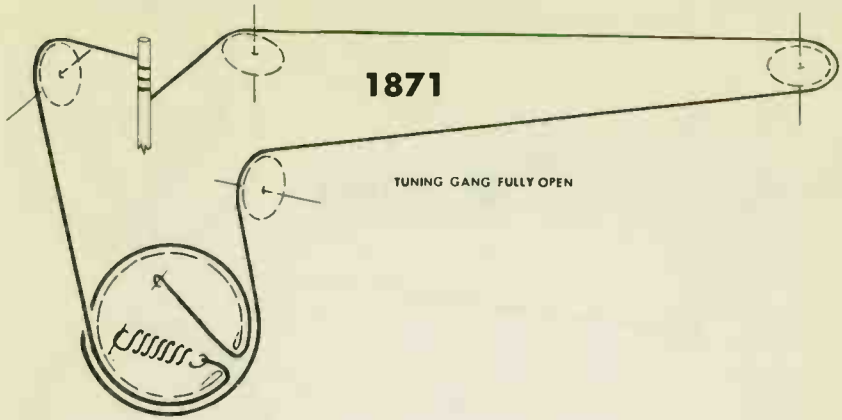

TUNING GANG FULLY CLOCKWISE

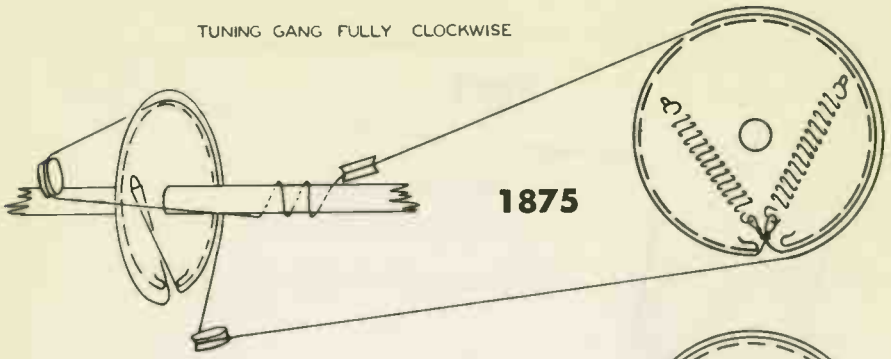

1875

TUNING GANG FULLY CLOSED

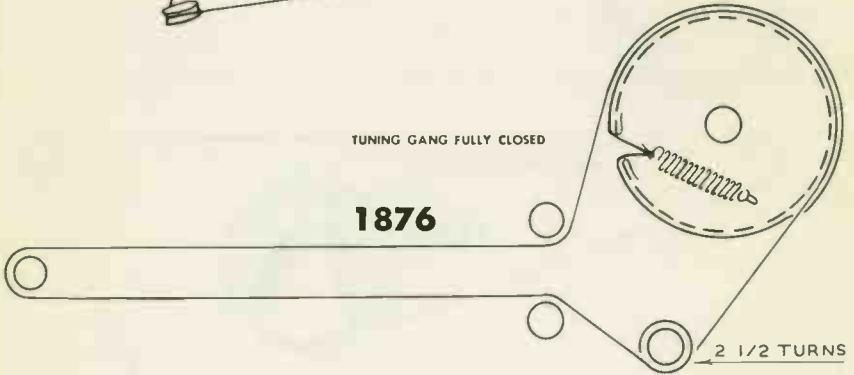

1876

2 1/2 TURNS

TUNING GANG FULLY CLOSED

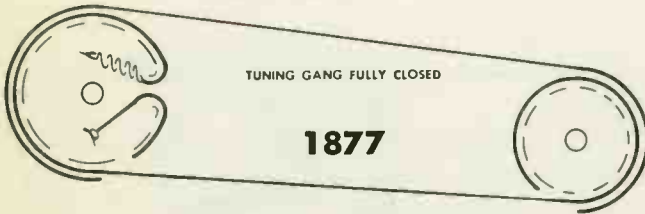

1877

8 1/2 TURNS

TUNED TO HIGH FREQUENCY END

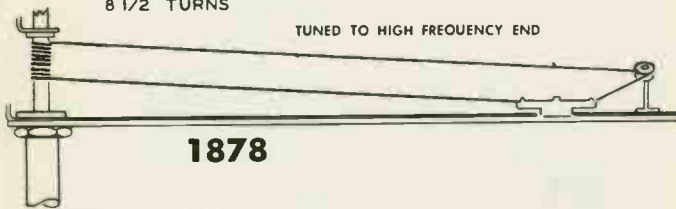

1878

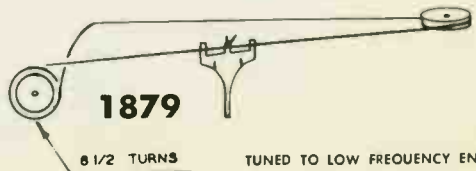

1879

8 1/2 TURNS

TUNED TO LOW FREQUENCY END

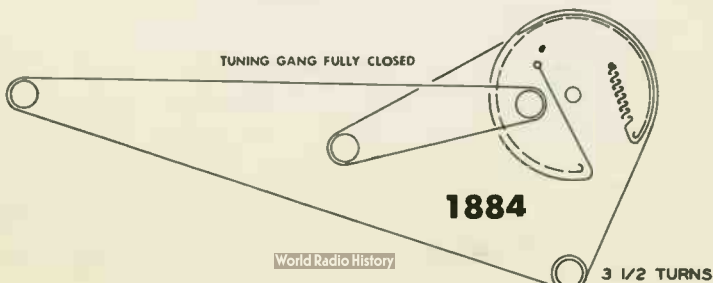
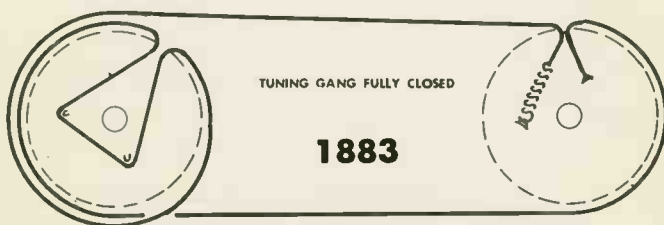
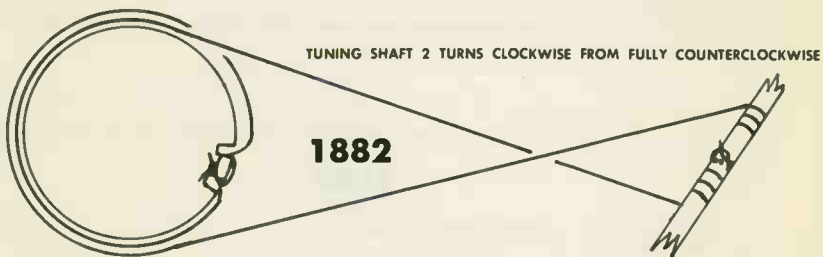
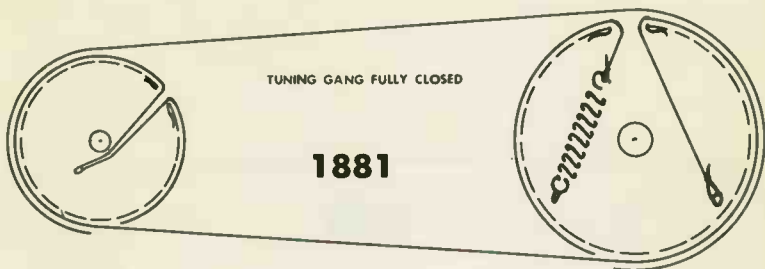
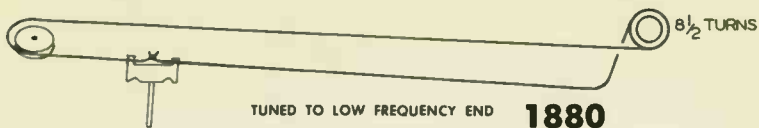

TUNING GANG FULLY CLOSED

1885

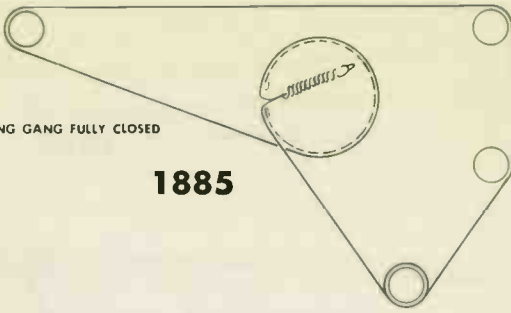

1886

TUNING GANG FULLY COUNTER-CLOCKWISE.

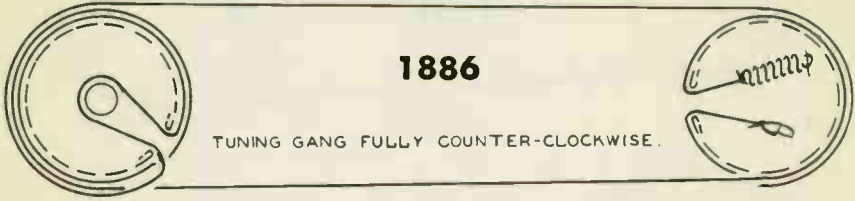

1887

TUNING GANG FULLY OPEN

1 1/4 TURNS

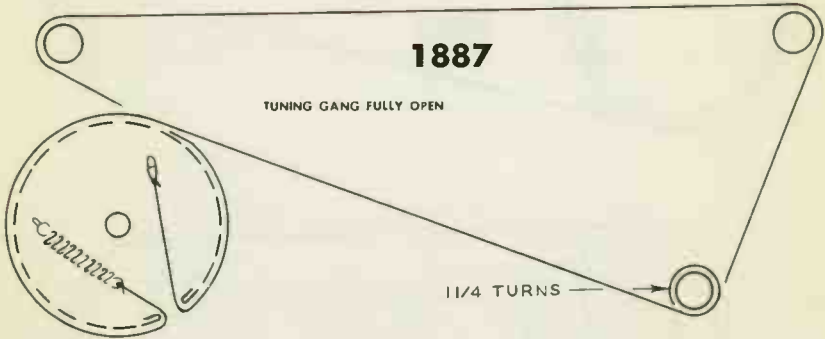

1888

TUNING GANG FULLY CLOSED

1 TURN

TUNING SHAFT

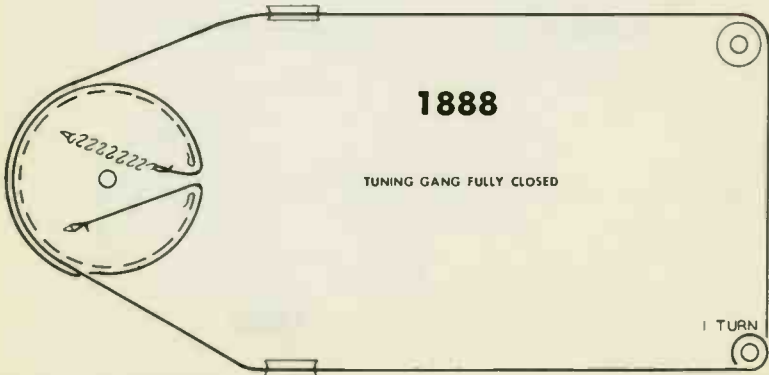

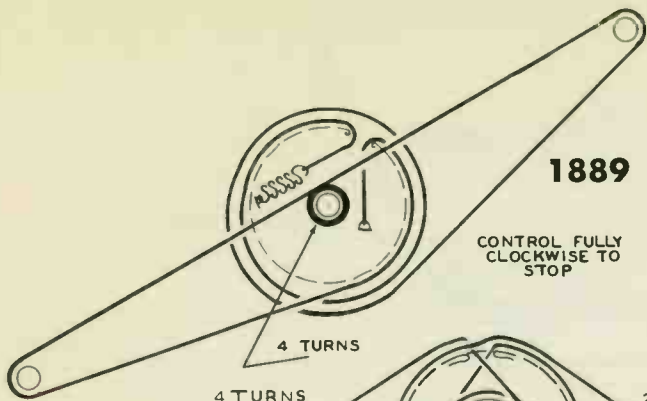

**1889**

CONTROL FULLY  
CLOCKWISE TO  
STOP

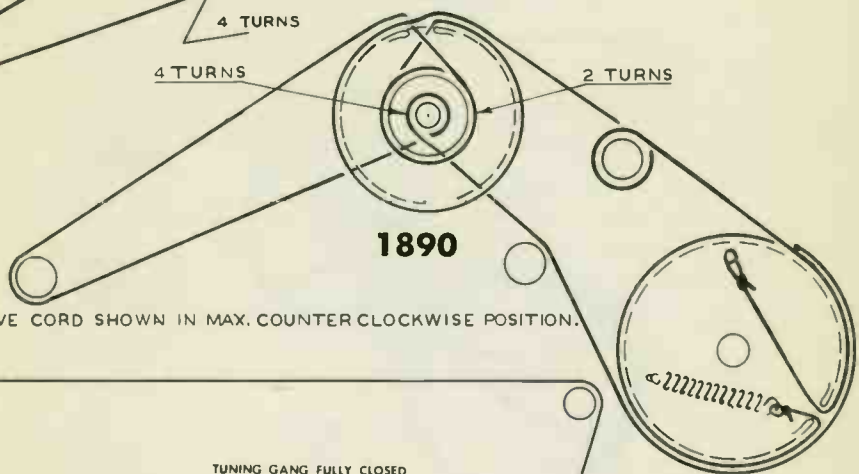

**1890**

DRIVE CORD SHOWN IN MAX. COUNTER CLOCKWISE POSITION.

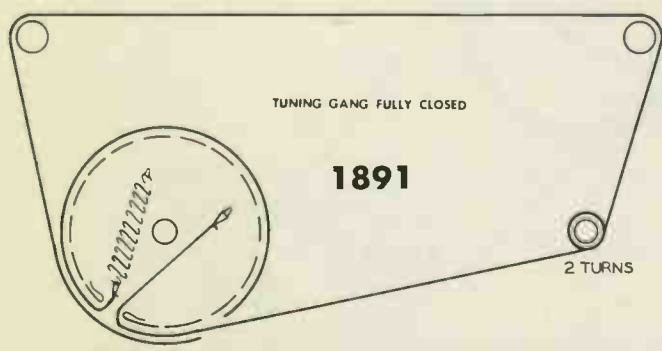

TUNING GANG FULLY CLOSED

**1891**

2 TURNS

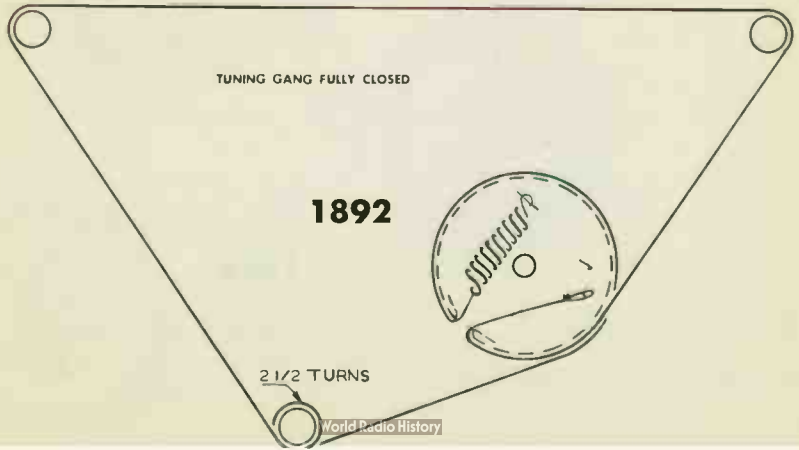

TUNING GANG FULLY CLOSED

**1892**

2 1/2 TURNS



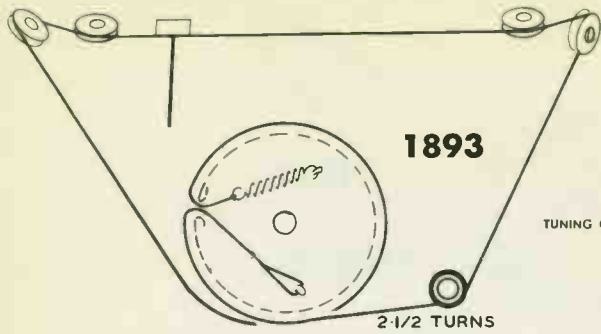

**1893**

TUNING GANG FULLY CLOSED

2-1/2 TURNS

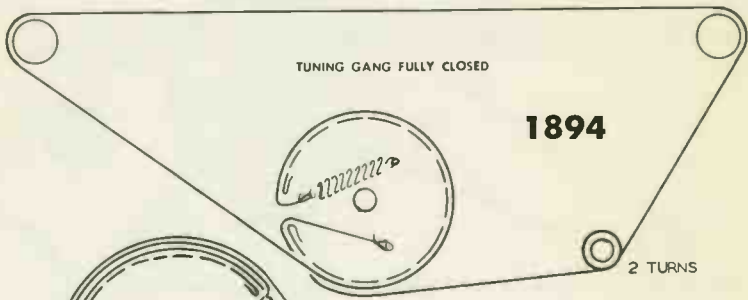

TUNING GANG FULLY CLOSED

**1894**

2 TURNS

TUNING GANG FULLY COUNTER-CLOCK WISE.

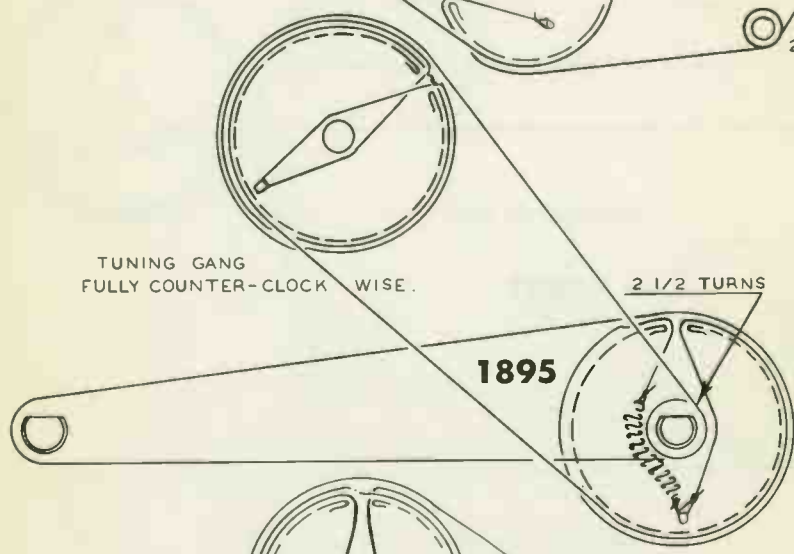

**1895**

2 1/2 TURNS

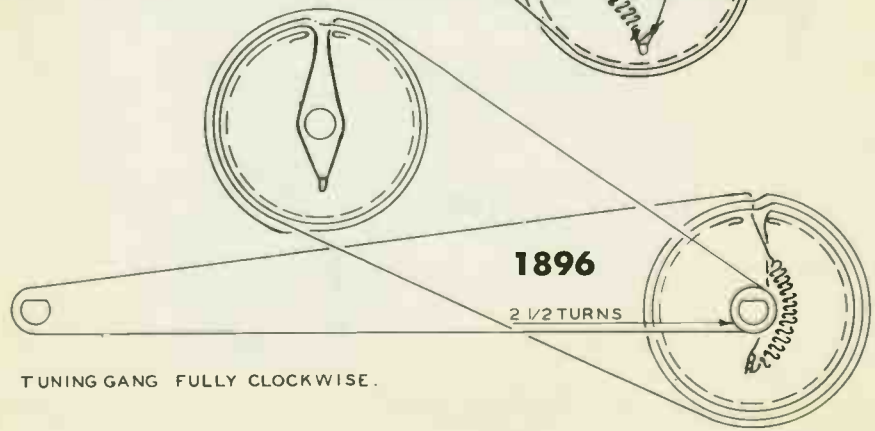

**1896**

2 1/2 TURNS

TUNING GANG FULLY CLOCKWISE.

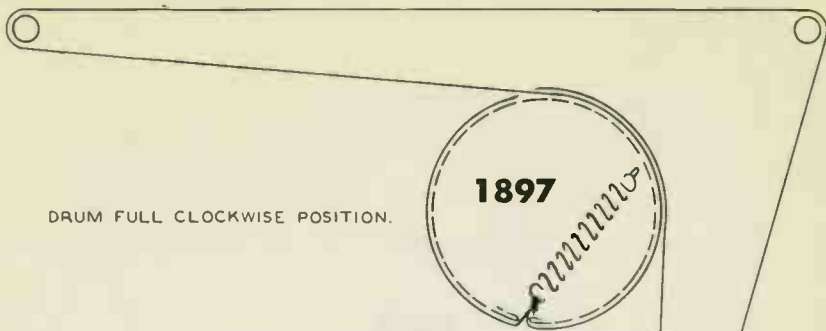

DRUM FULL CLOCKWISE POSITION.

**1897**

3 1/2 TURNS

UHF TUNING SHAFT FULLY COUNTER-CLOCKWISE

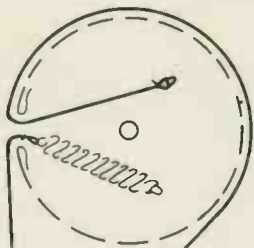

**1898**

2 TURNS

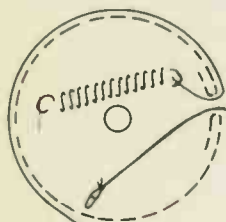

**1899**

UHF PULLEY SHAFT IN FULL CLOCKWISE POSITION.



TUNING GANG FULLY CLOSED

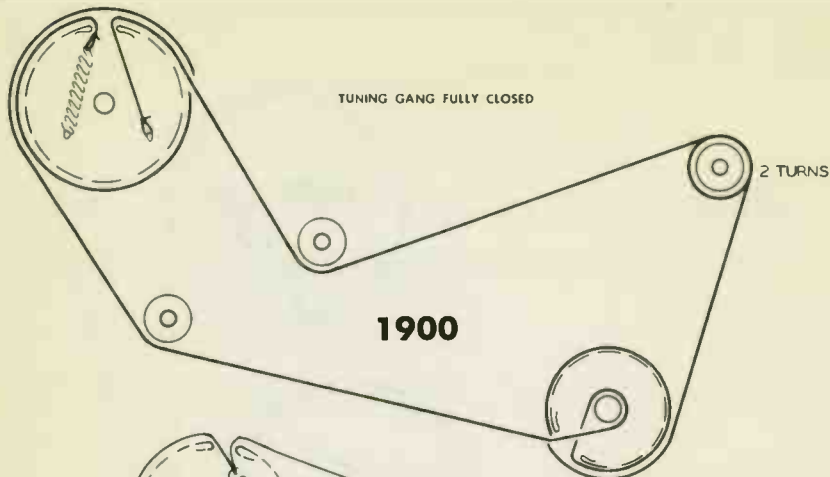

TUNING GANG FULLY OPEN

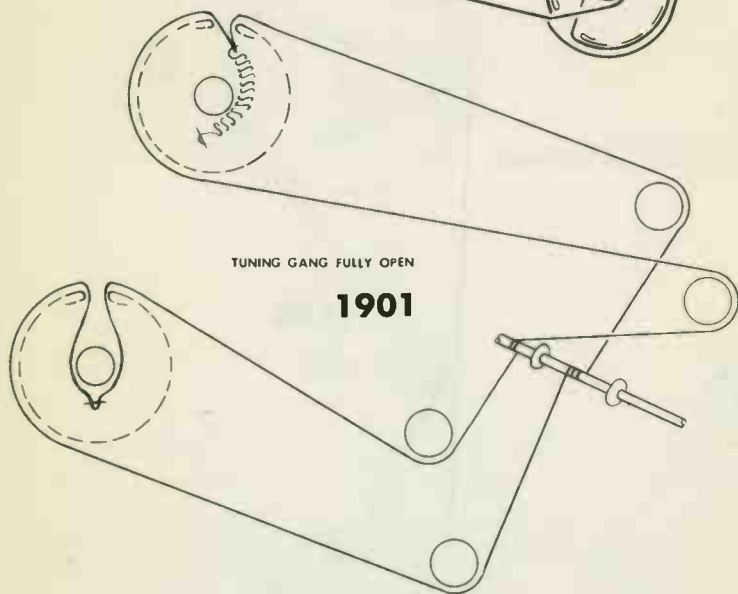

TUNING GANG FULLY CLOSED

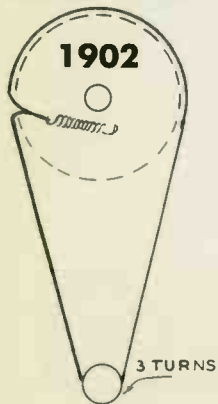

STEP 1

1 1/2 MM SLEEVING - 1/4" LONG  
INSERTED ON LANCE BEFORE  
WRAPPING DIAL CORD ONE  
TURN AROUND LANCE.

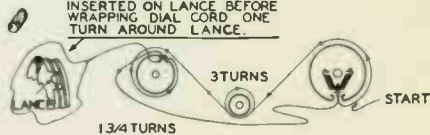

STEP 2

TUNING SHAFT FULLY COUNTERCLOCKWISE

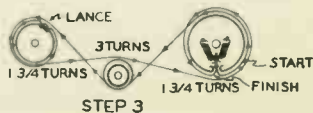

STEP 3

1903

**1904**

FULL COUNTER  
CLOCKWISE  
POSITION

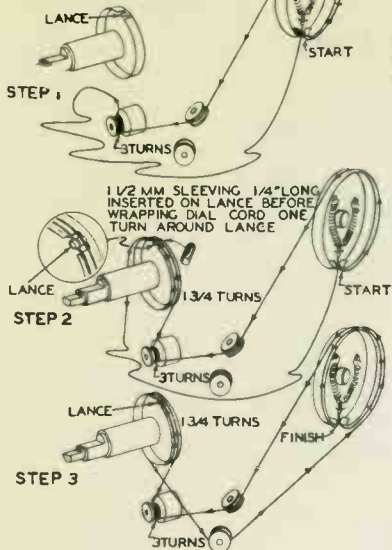

2 1/2 TURNS

TUNING GANG FULLY CLOSED

**1905**

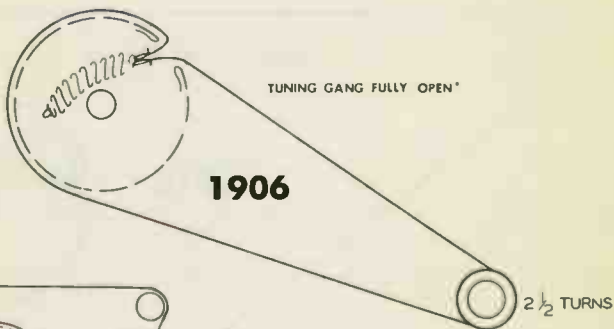
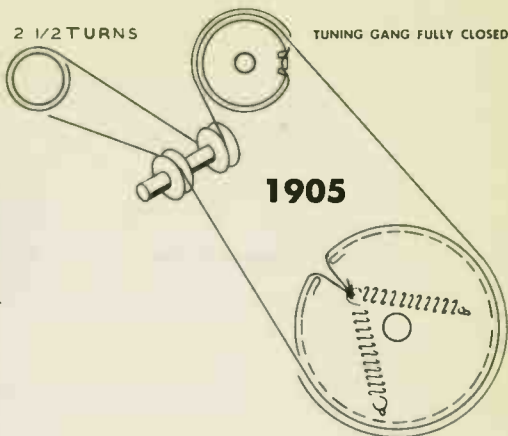

TUNING GANG FULLY OPEN\*

**1906**

2 1/2 TURNS

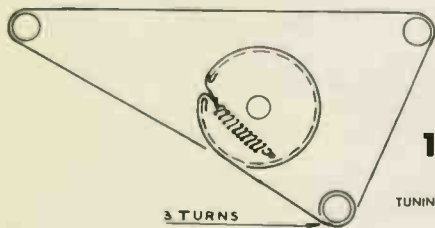

3 TURNS

**1907**

TUNING GANG FULLY CLOSED

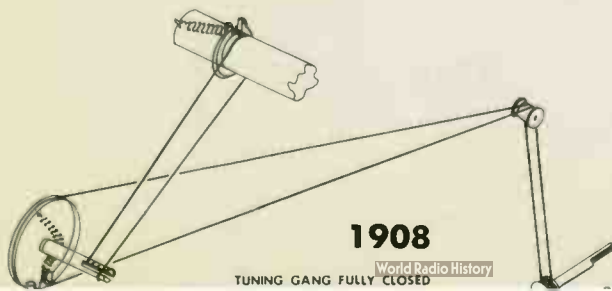

**1908**

TUNING GANG FULLY CLOSED

World Radio History

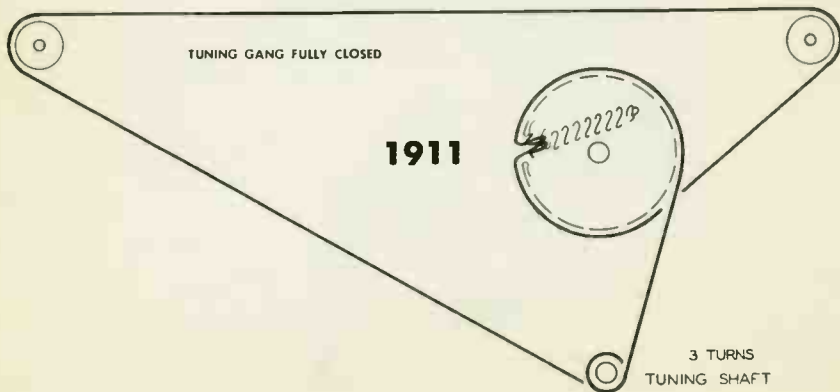
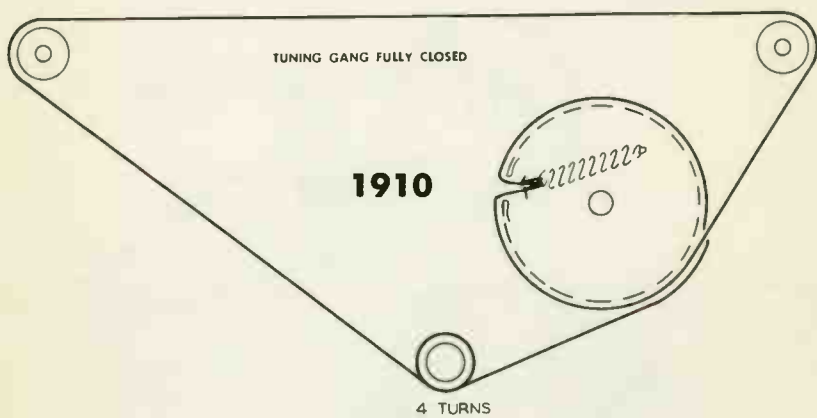
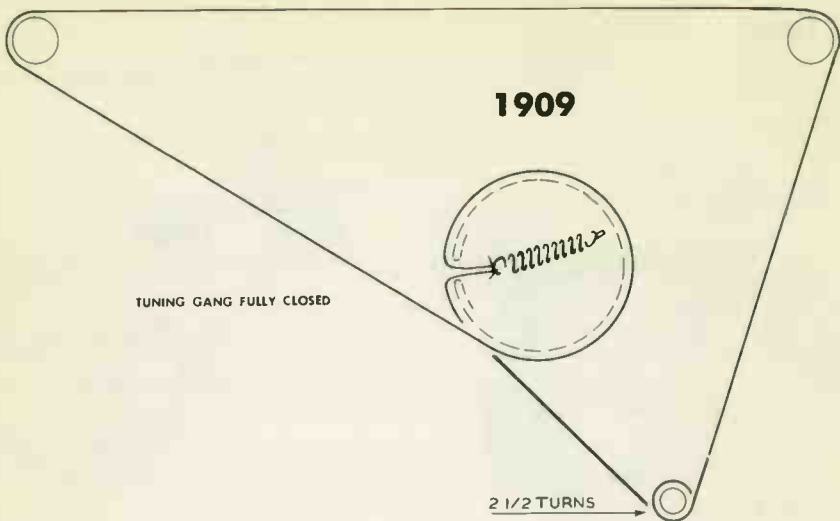

3 TURNS

1912

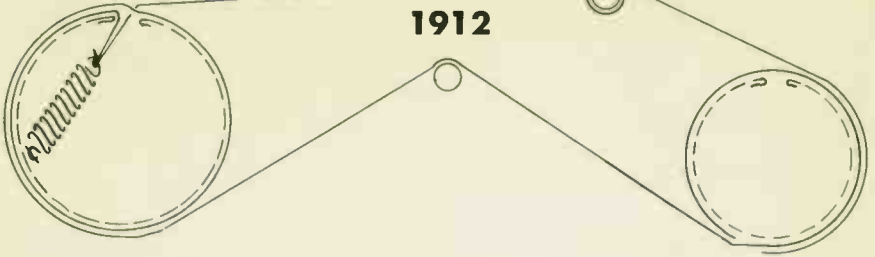

3 TURNS

1913



1914

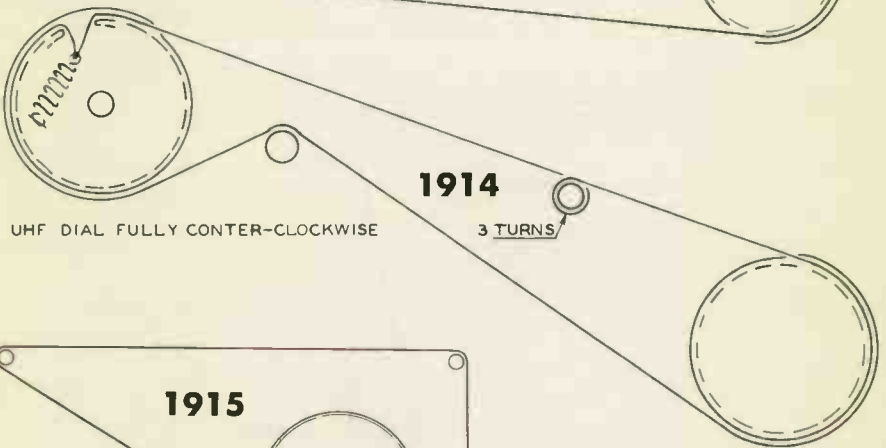

UHF DIAL FULLY CENTER-CLOCKWISE

3 TURNS

1915

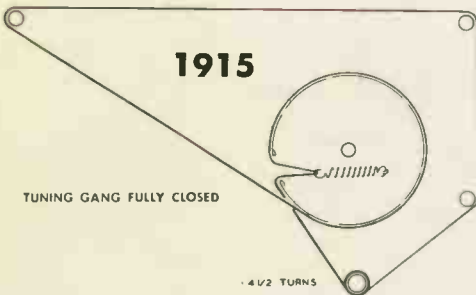

TUNING GANG FULLY CLOSED

4 1/2 TURNS

TUNING GANG FULLY CLOSED

1916

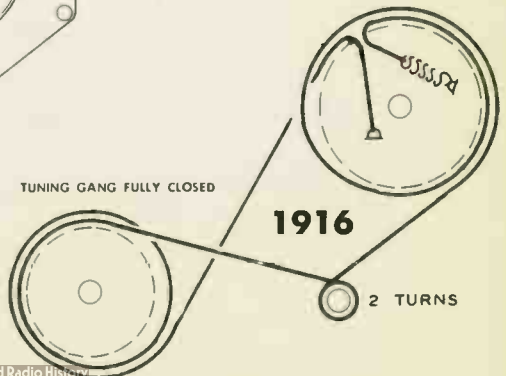

2 TURNS

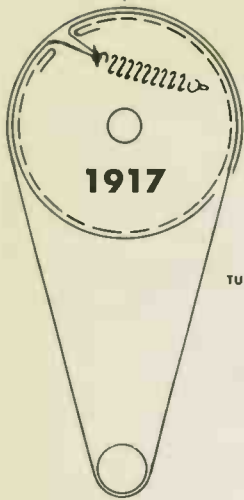

**1917**

TUNING GANG FULLY, OPEN

TUNING GANG FULLY CLOSED



**1918**

1 1/2 TURNS



TUNED TO HIGH FREQUENCY END

**1919**

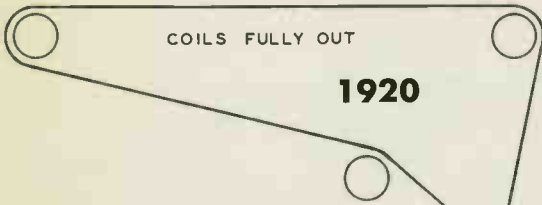

COILS FULLY OUT

**1920**

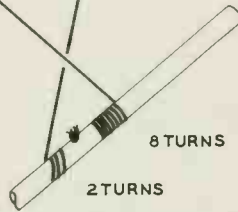

8 TURNS

2 TURNS

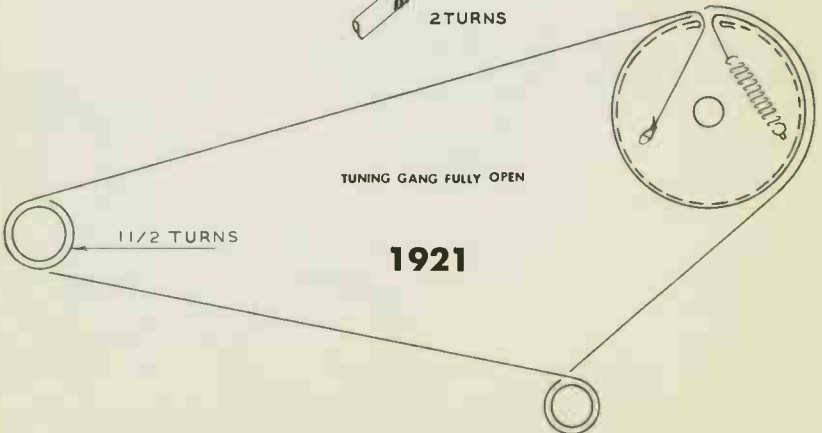

TUNING GANG FULLY OPEN

**1921**

1 1/2 TURNS

TUNING GANG FULLY CLOSED

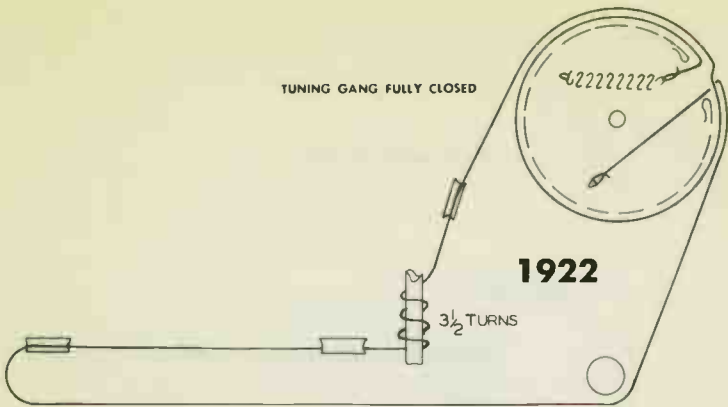

TUNING GANG FULLY CLOSED

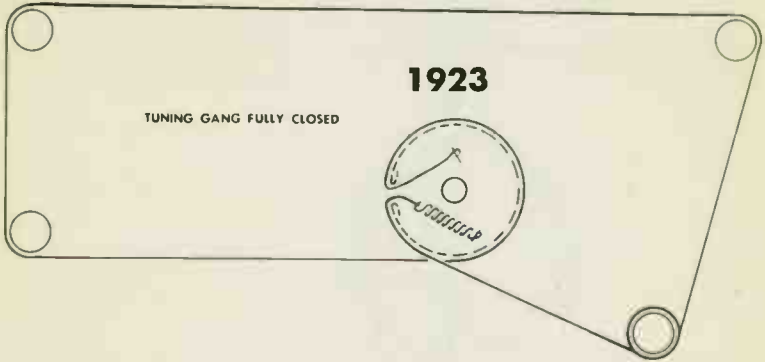

TUNING GANG FULLY COUNTER-CLOCKWISE

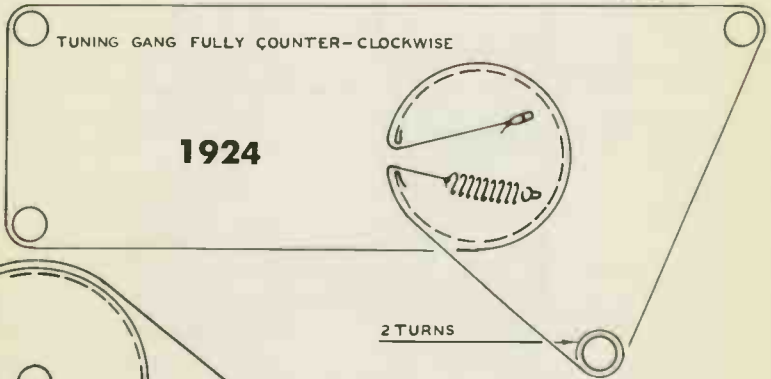

1925

TUNING GANG FULLY CLOSED

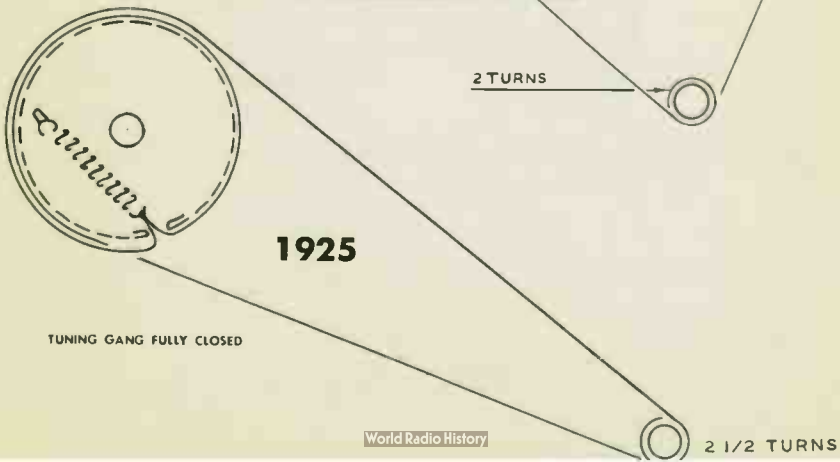



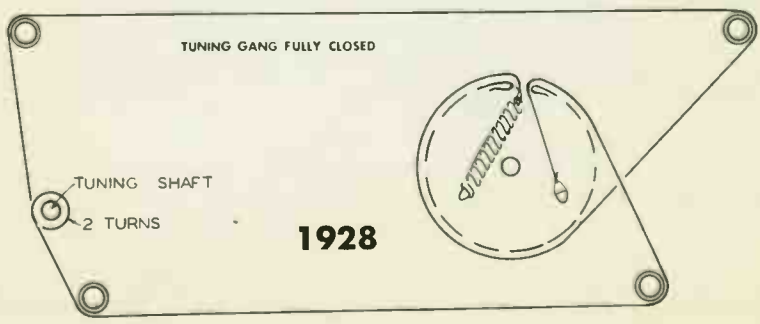
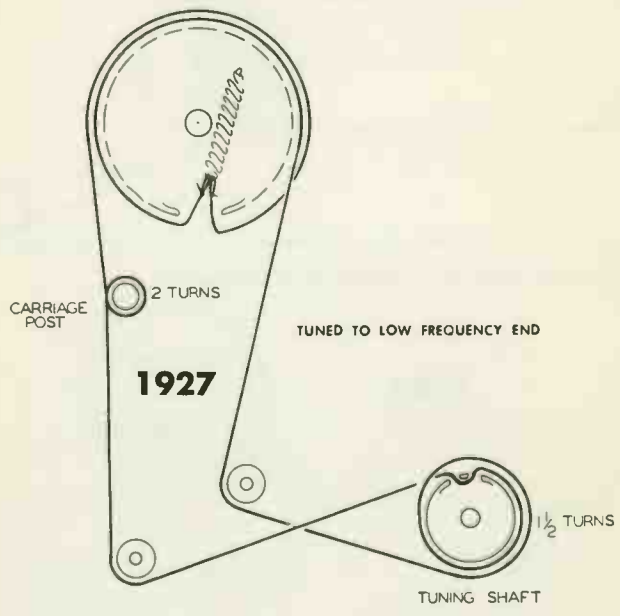
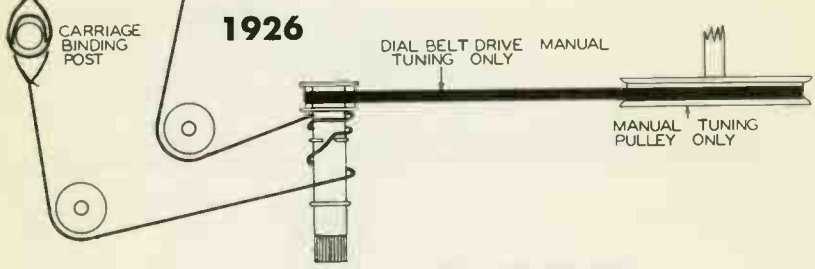
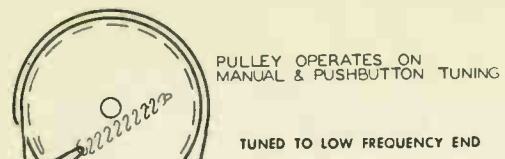

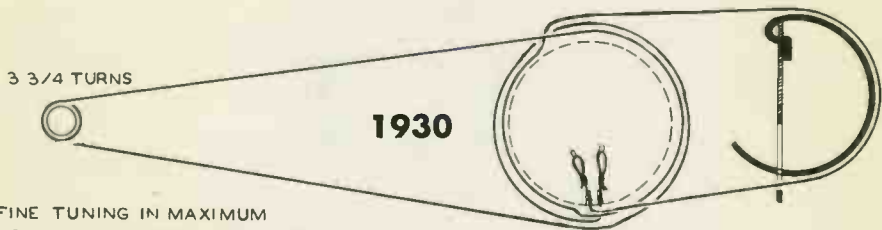
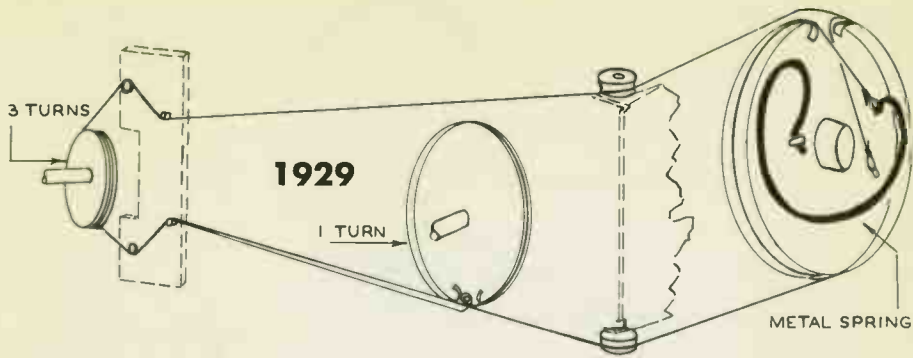

FINE TUNING IN MAXIMUM  
COUNTERCLOCKWISE POSITION.

EARLY PRODUCTION

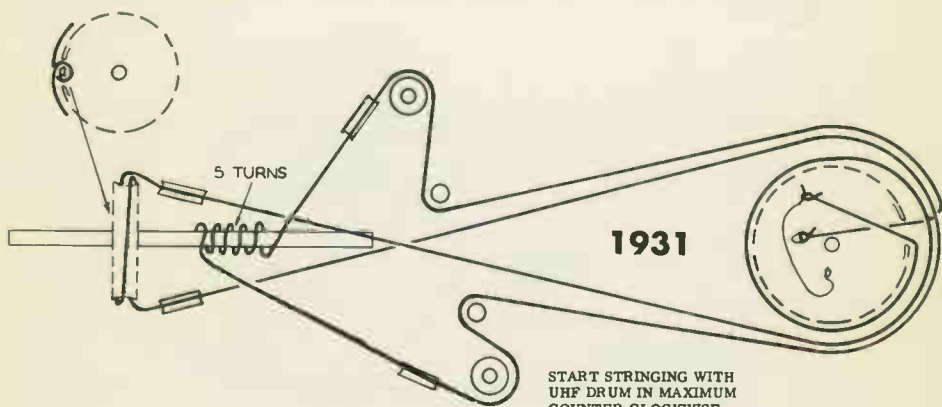

START STRINGING WITH  
UHF DRUM IN MAXIMUM  
COUNTER CLOCKWISE  
POSITION.

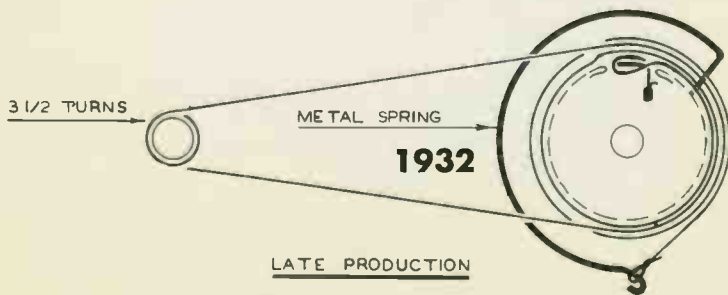

LATE PRODUCTION

TUNING GANG FULLY OPEN

1933



TUNING GANG FULLY CLOSED

1934

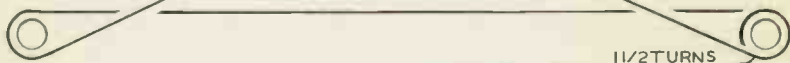

1935

2 TURNS

TUNING GANG FULLY CLOCKWISE

← START

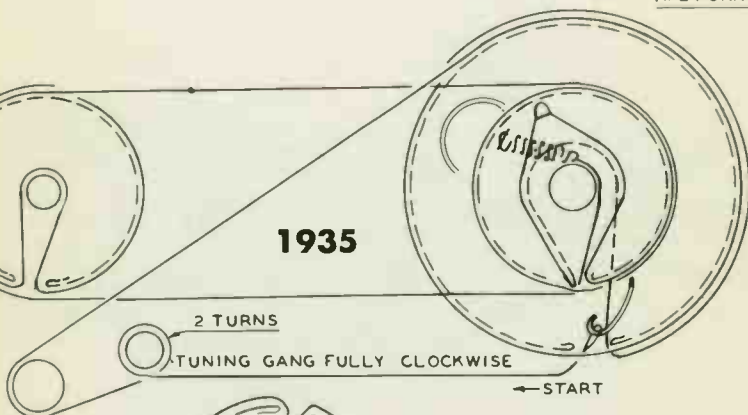

TUNING GANG FULLY OPEN

1936

2 1/2 TURNS

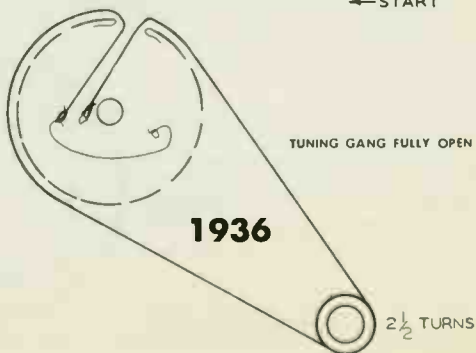

3 TURNS

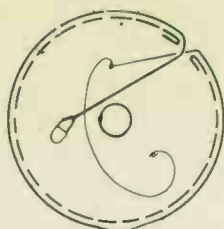

**1937**

TUNING GANG FULLY OPEN

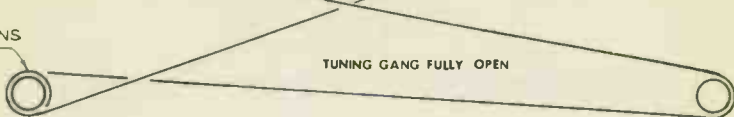

TUNING GANG FULLY OPEN

**1938**

2 TURNS



TUNING GANG FULLY OPEN

**1939**

3 TURNS



**1940**

TUNING GANG FULLY CLOSED

2  $\frac{3}{4}$  TURNS

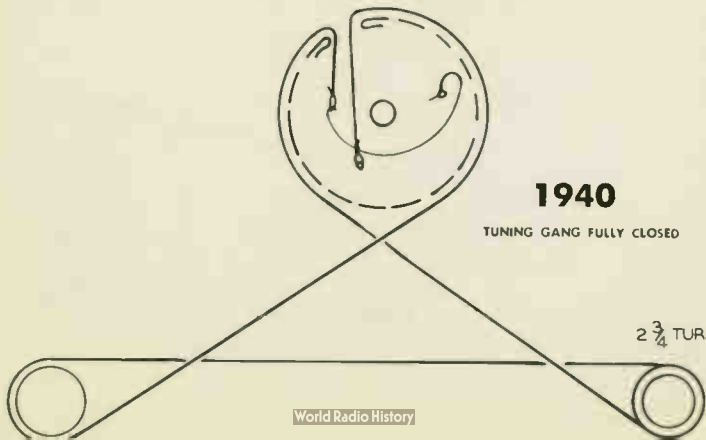

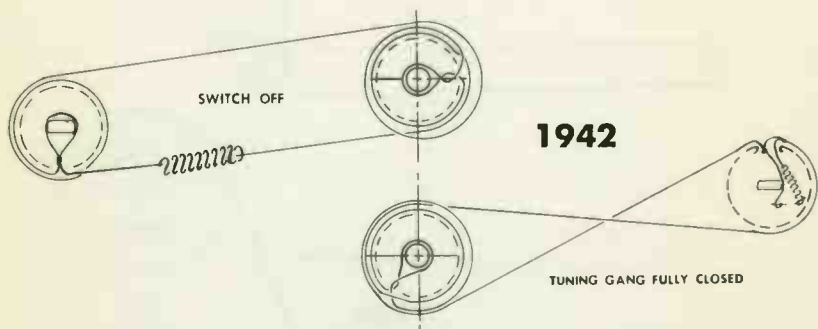
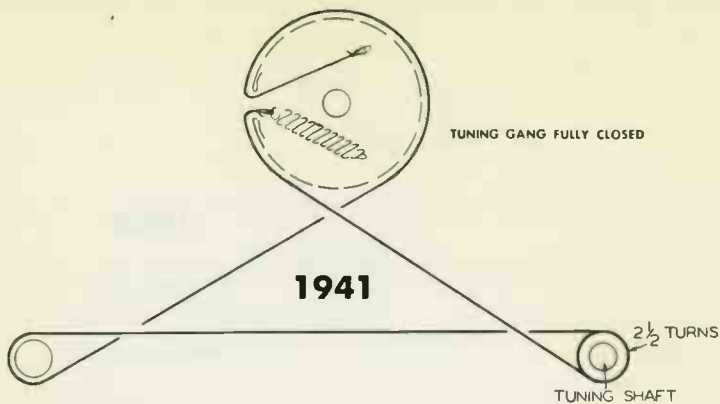

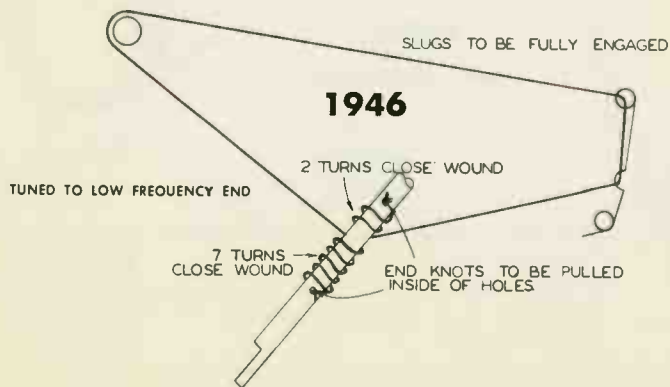
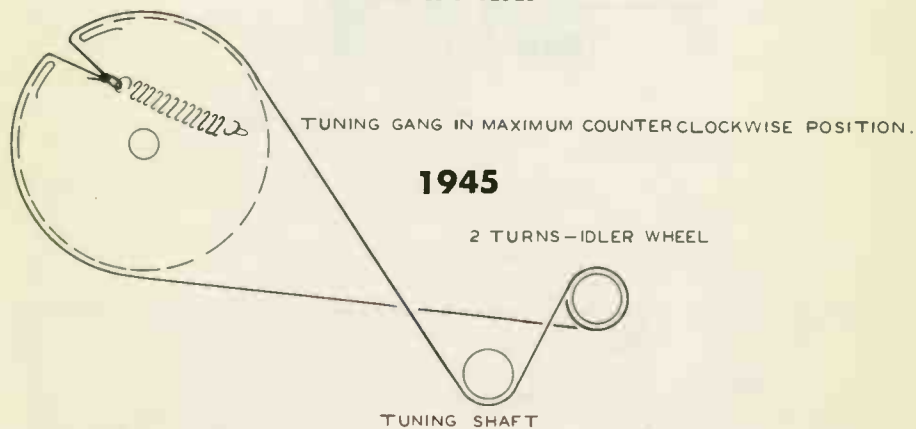
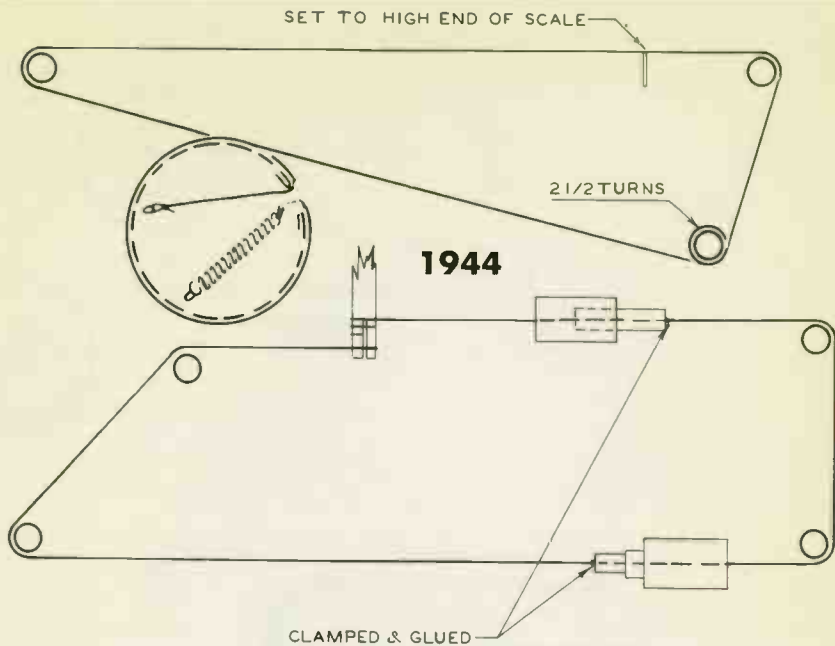

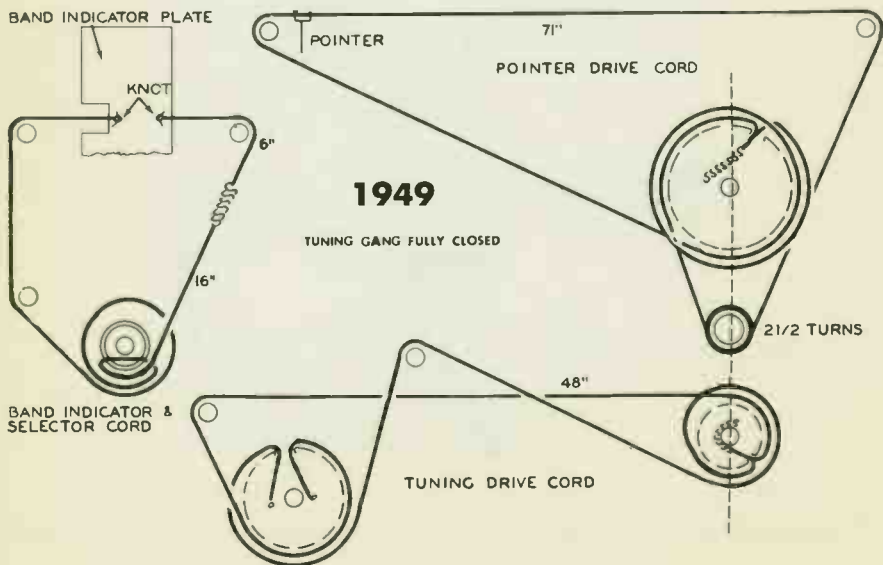
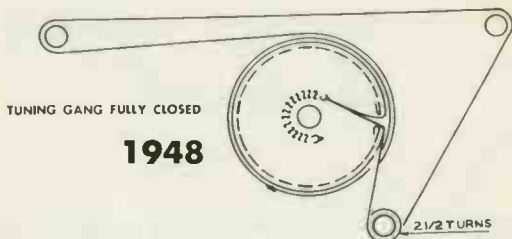
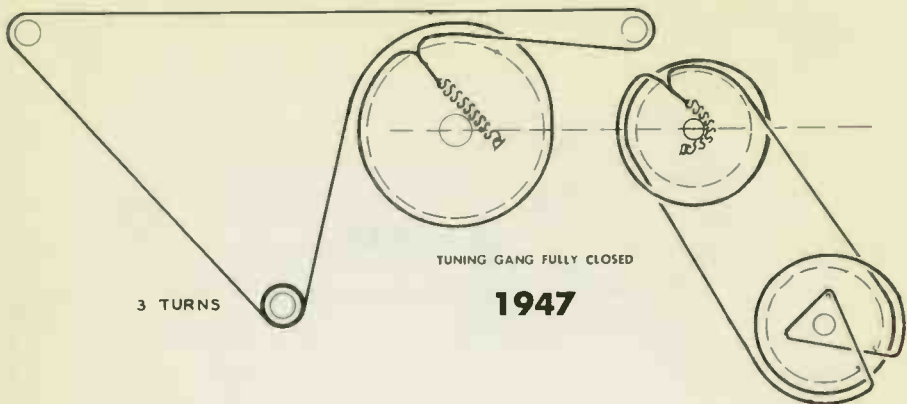

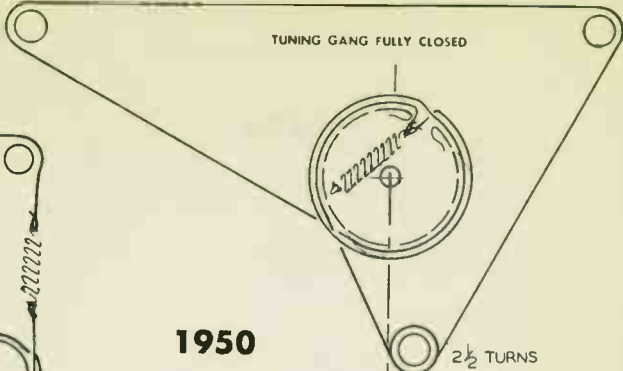
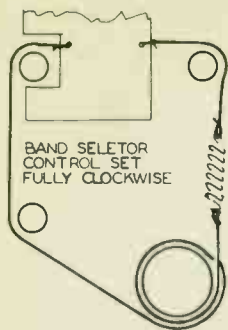

1950

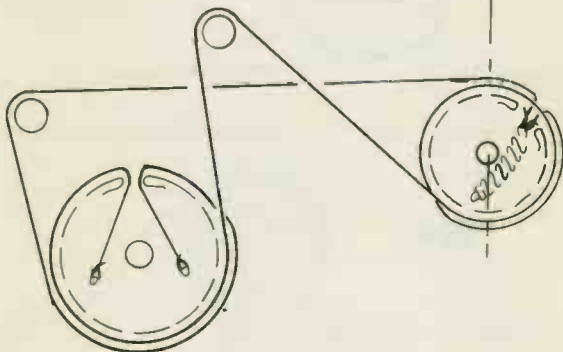

1951

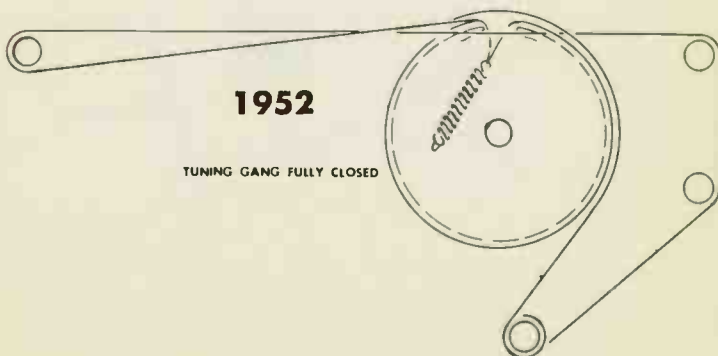

1952



TUNING GANG FULLY CLOSED

1953

2 TURNS

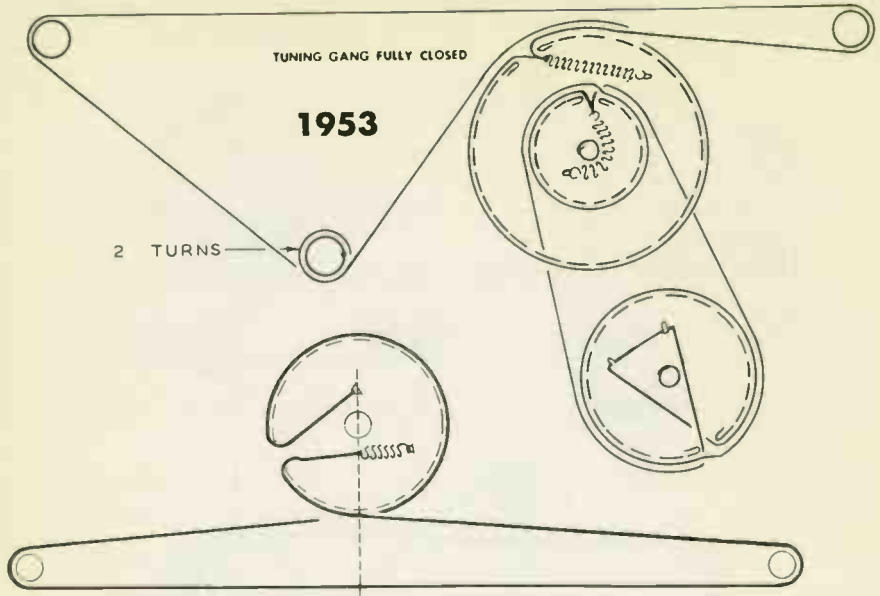

1954

TUNING GANG FULLY CLOSED

3 1/2

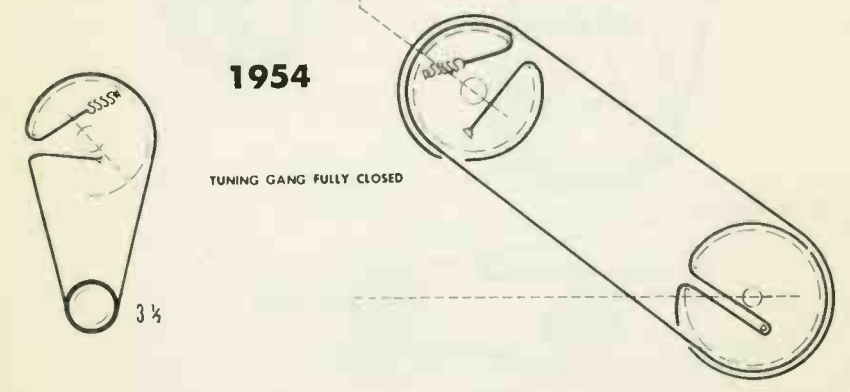

TUNING GANG FULLY CLOSED

1955

2 1/2 TURNS

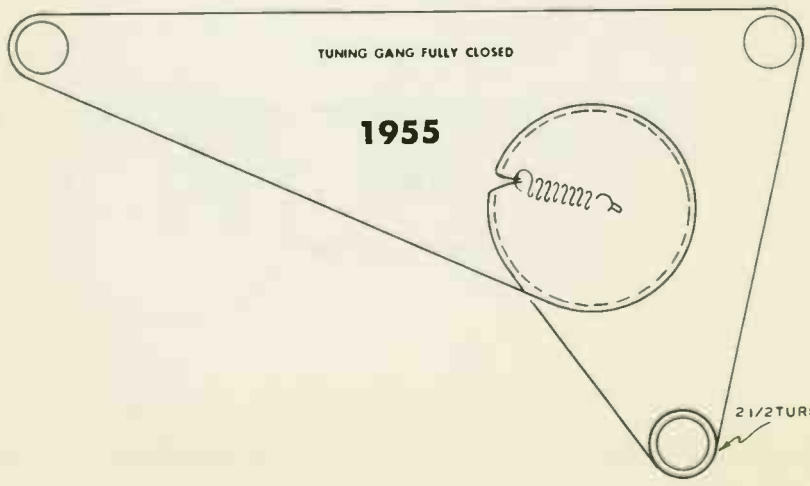

TUNING GANG FULLY CLOSED

1956

3 1/2 TURNS

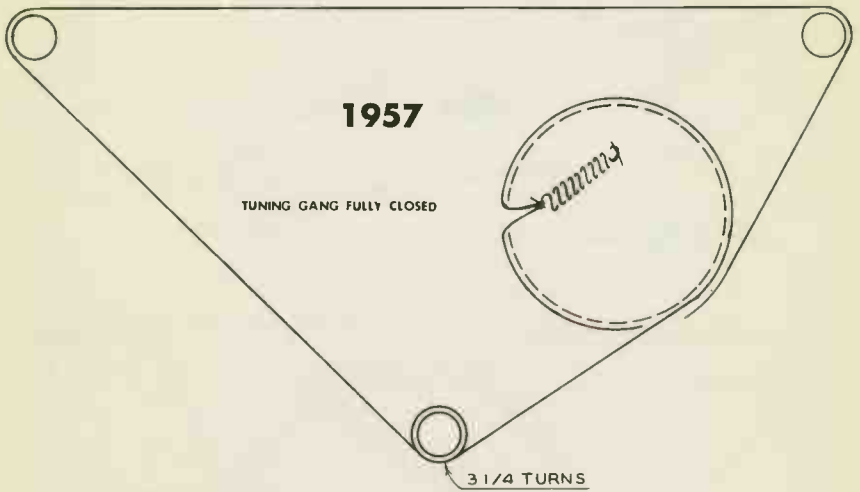

TUNING GANG FULLY OPEN

1958

TUNING GANG FULLY CLOSED

1959

TUNING SHAFT

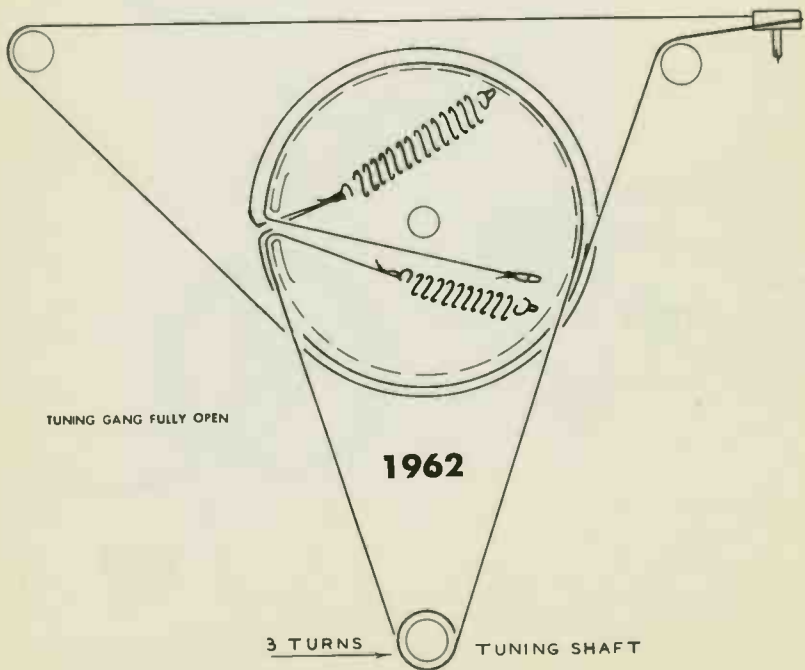
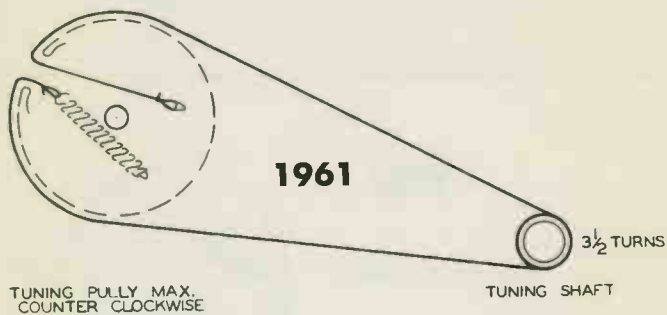
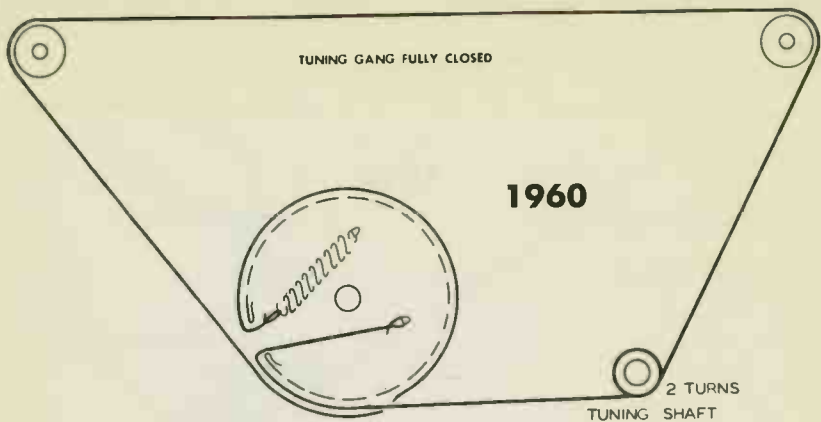

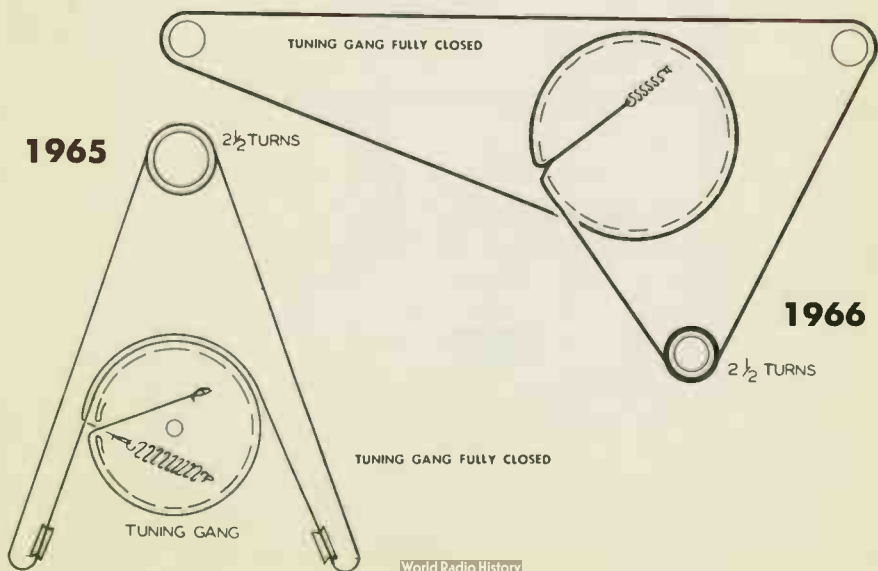
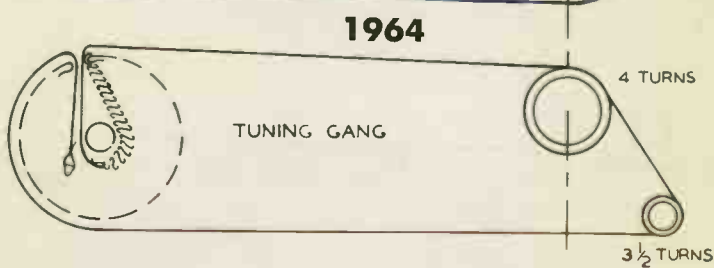
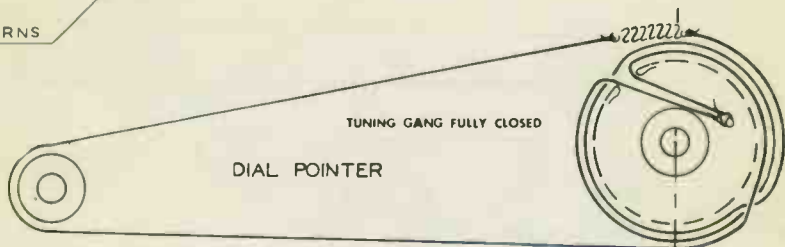
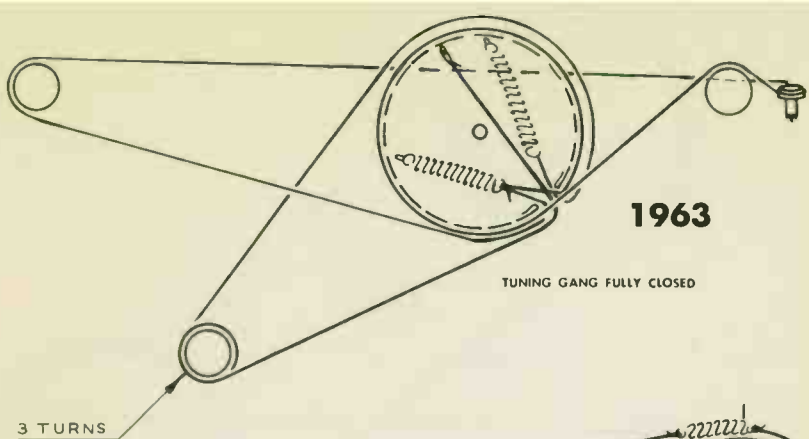

TUNING GANG FULLY CLOSED

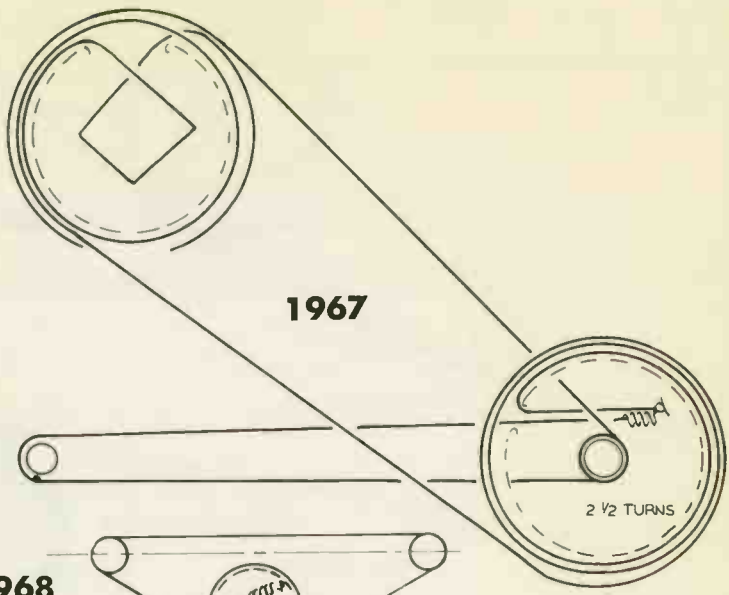

**1967**

2 1/2 TURNS



**1968**

TUNING GANG FULLY CLOSED

2 1/2 TURNS

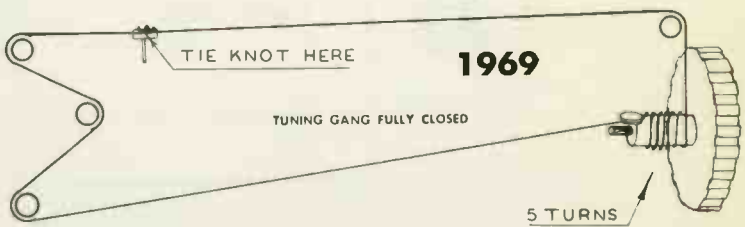

**1969**

TIE KNOT HERE

TUNING GANG FULLY CLOSED

5 TURNS

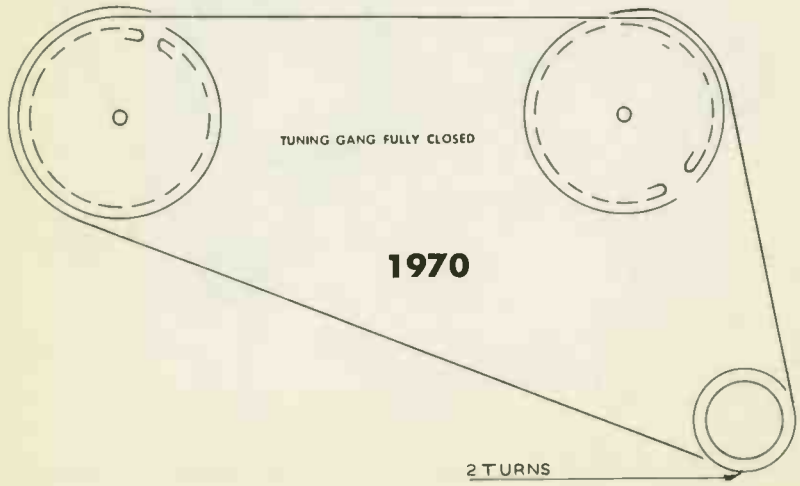

**1970**

TUNING GANG FULLY CLOSED

2 TURNS

TUNING GANG FULLY CLOSED

1971

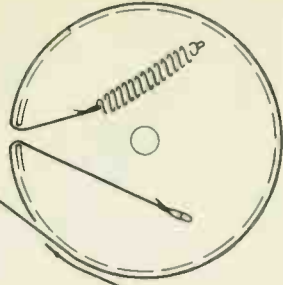

3 TURNS ON TUNING SHAFT.

TUNING GANG FULLY CLOSED

1972

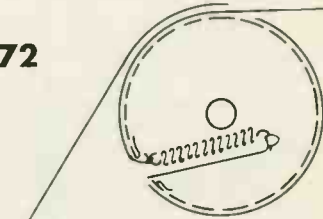

3 1/2 TURNS

1973

TUNING GANG FULLY CLOSED

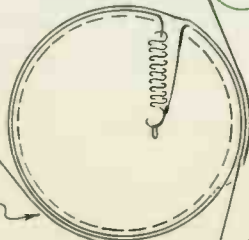

RIDES ON BOTTOM OF PULLEY

3 TURNS



TUNED TO HIGH FREQUENCY END

**1974**

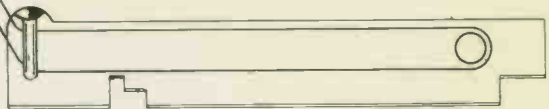

3 TURNS

7 TURNS

TUNING CONTROL

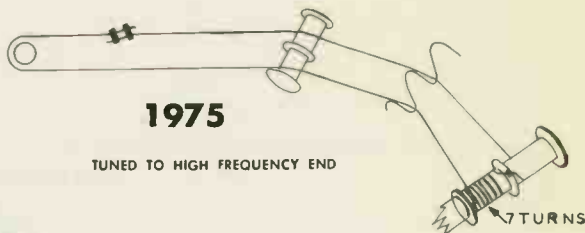

**1975**

TUNED TO HIGH FREQUENCY END

7 TURNS

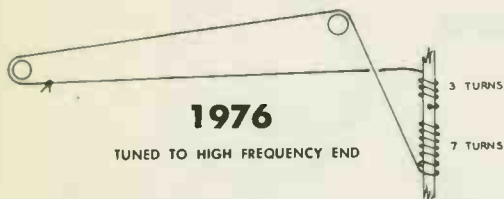

**1976**

TUNED TO HIGH FREQUENCY END

3 TURNS

7 TURNS

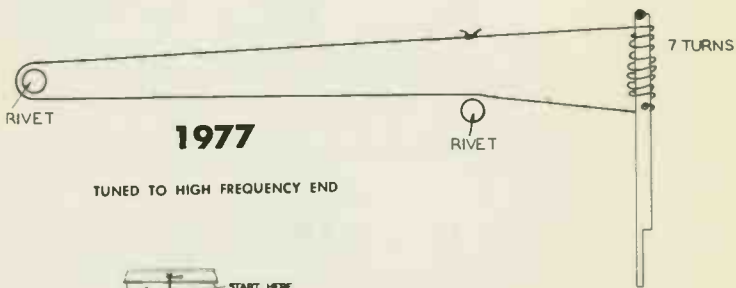

7 TURNS

RIVET

**1977**

RIVET

TUNED TO HIGH FREQUENCY END

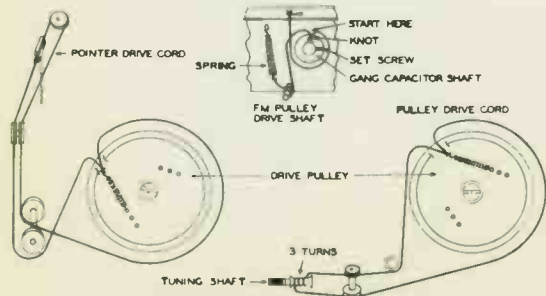

POINTER DRIVE CORD

SPRING

F4 PULLEY DRIVE SHAFT

START HERE

KNOT

SET SCREW

GANG CAPACITOR SHAFT

PULLEY DRIVE CORD

DRIVE PULLEY

3 TURNS

TUNING SHAFT

TUNING GANG FULLY CLOSED

**1978**

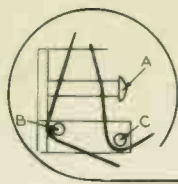

TUNING GANG FULLY CLOSED

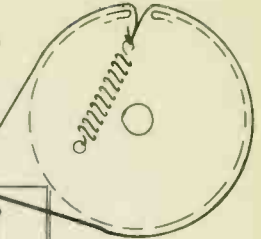
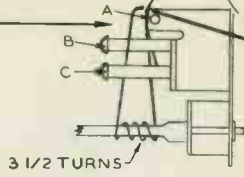

# 1979

TUNING GANG FULLY CLOSED

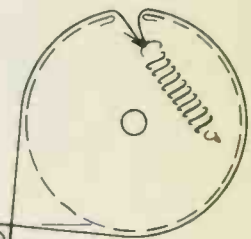
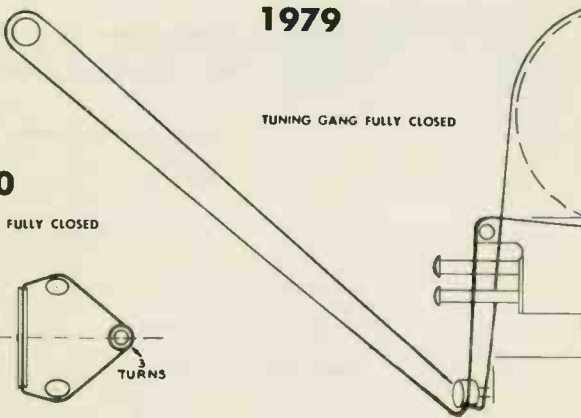

# 1980

TUNING GANG FULLY CLOSED

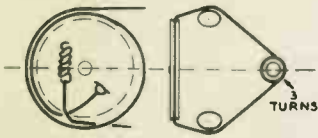

TUNING GANG FULLY CLOSED

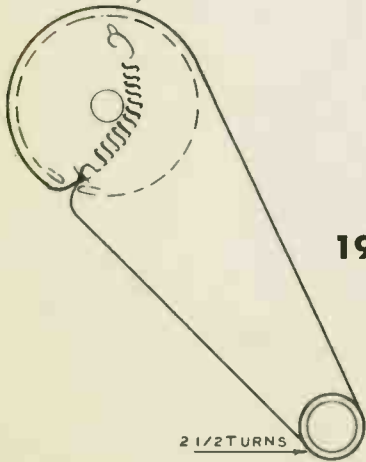

# 1981

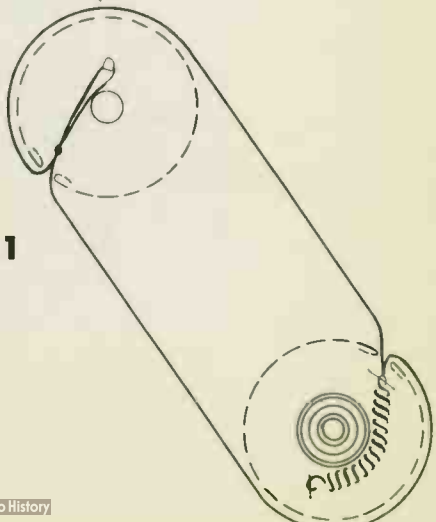



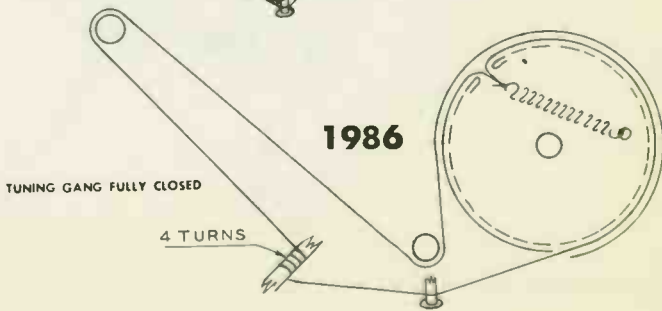
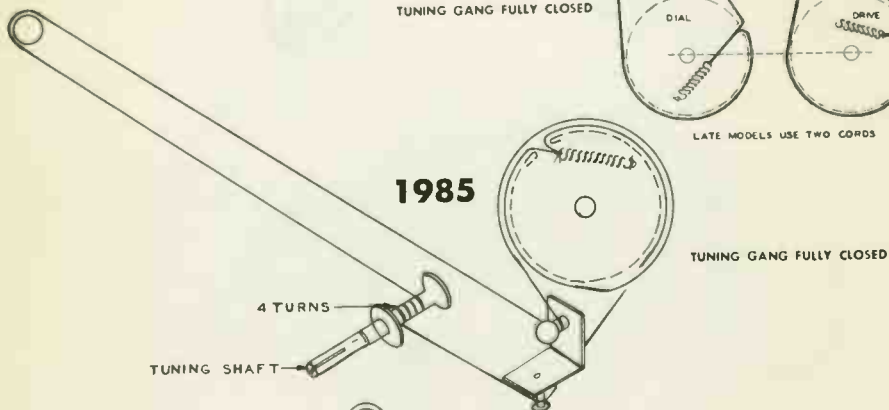
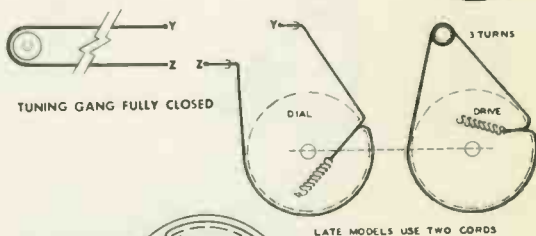
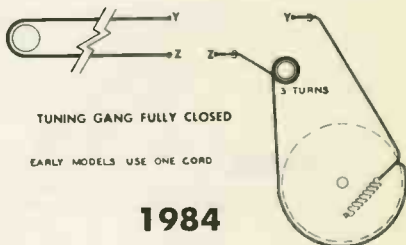
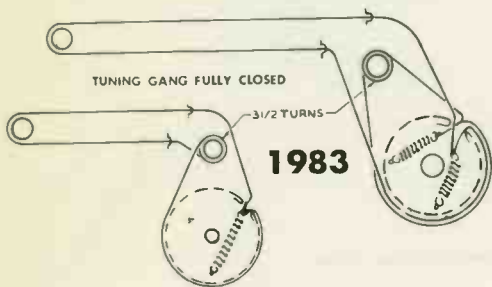
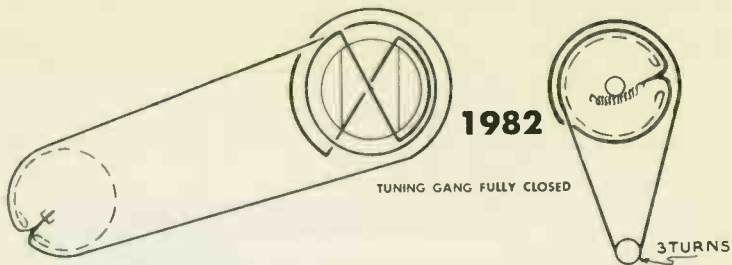

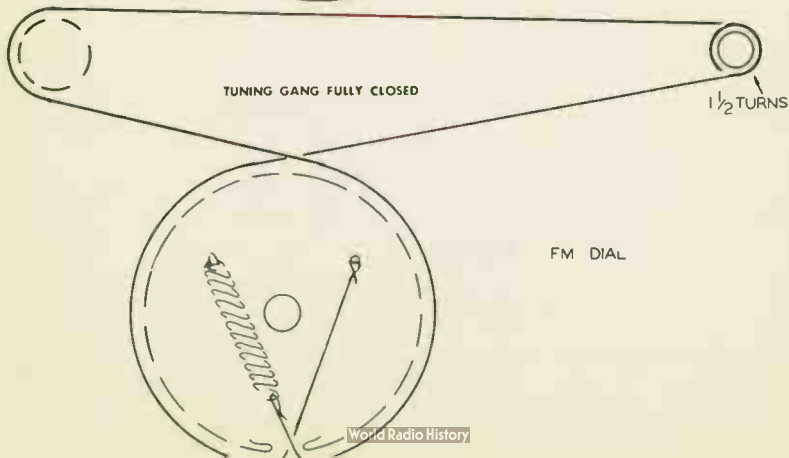
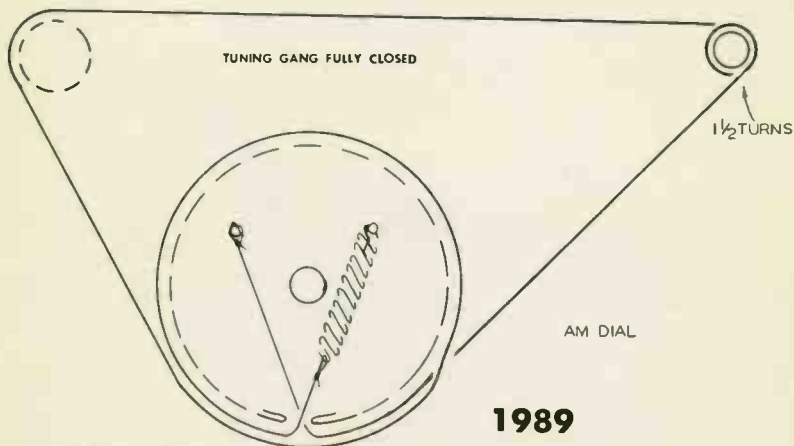
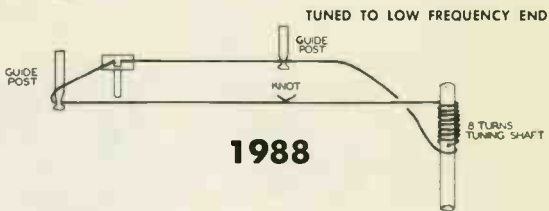
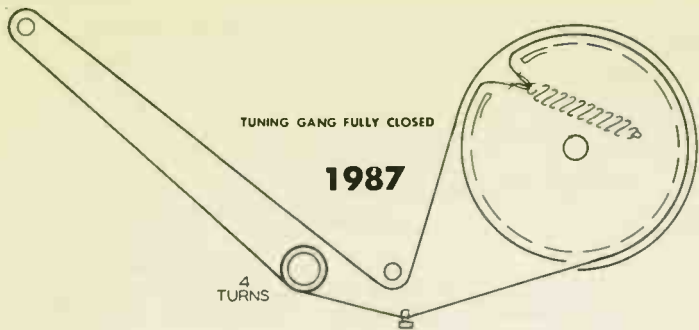

BAND SPREAD DIAL  
CORD ASSEMBLY

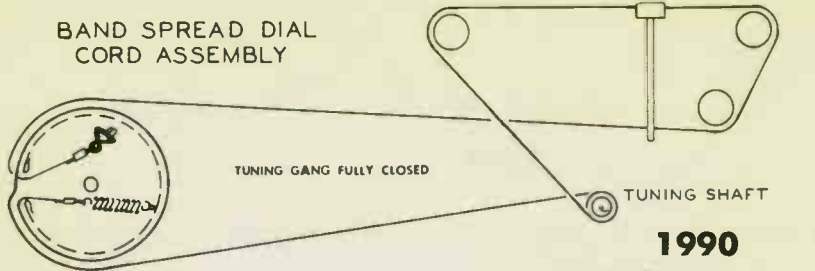

CORD LEGEND	
CORD-B S. DIAL	L = 573/8"
CORD-GC DIAL	L = 46"

GENERAL COVERAGE  
DIAL CORD ASSEMBLY

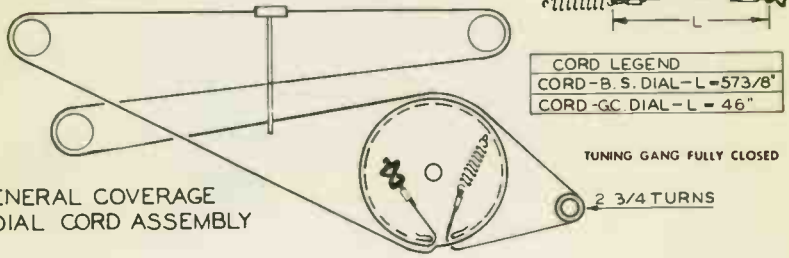

**1991**



**1992**

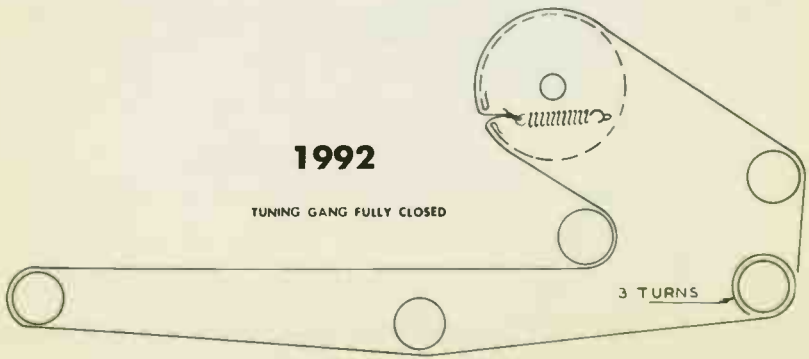

# AM DRIVE CORD STRINGING

(DIAL POINTER MOVEMENT)

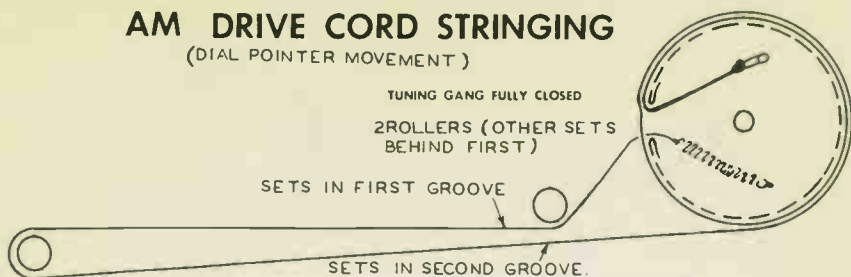

# AM DRIVE CORD STRINGING

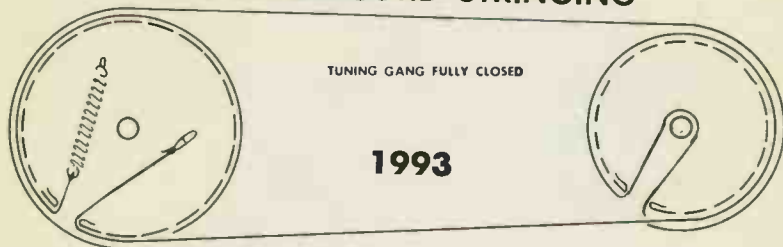

# UHF DRIVE CORD STRINGING

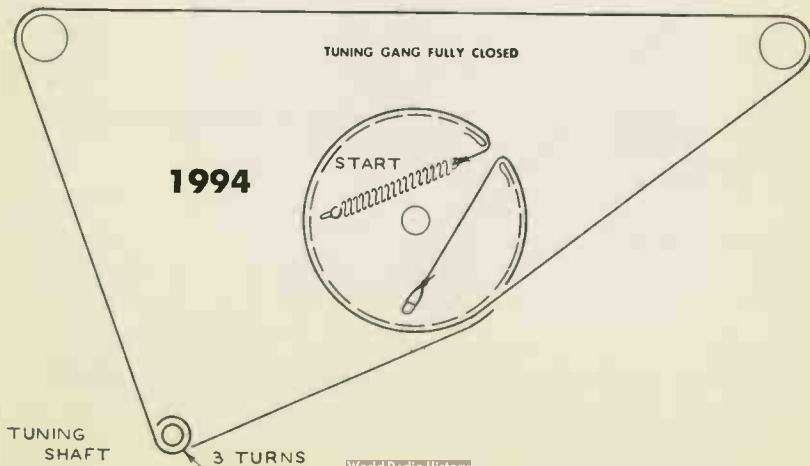
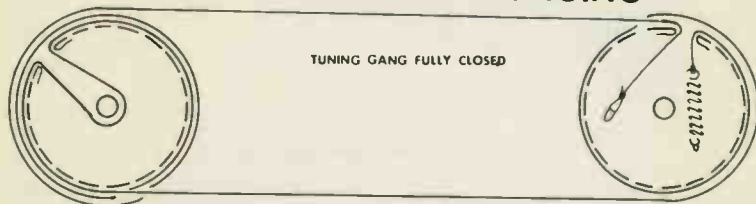

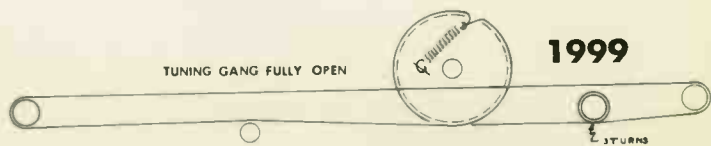
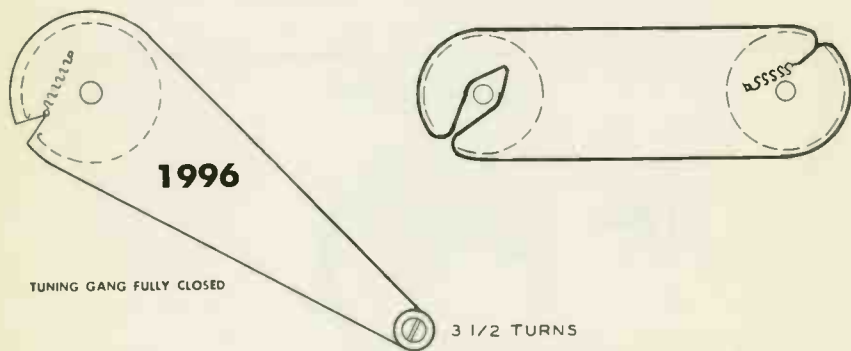
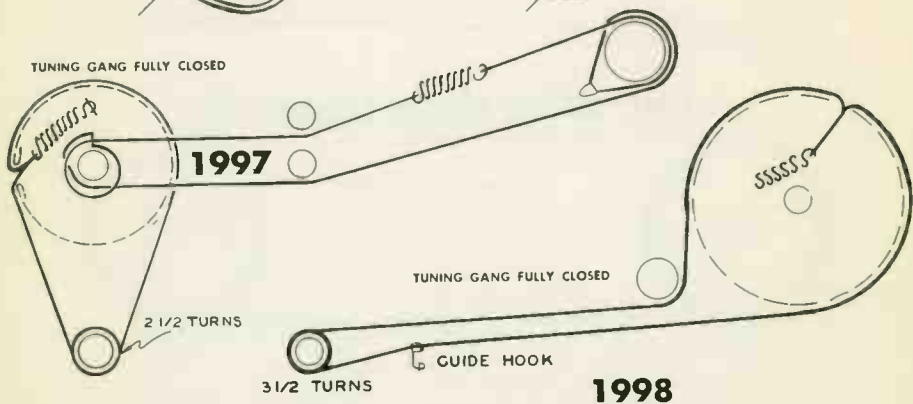
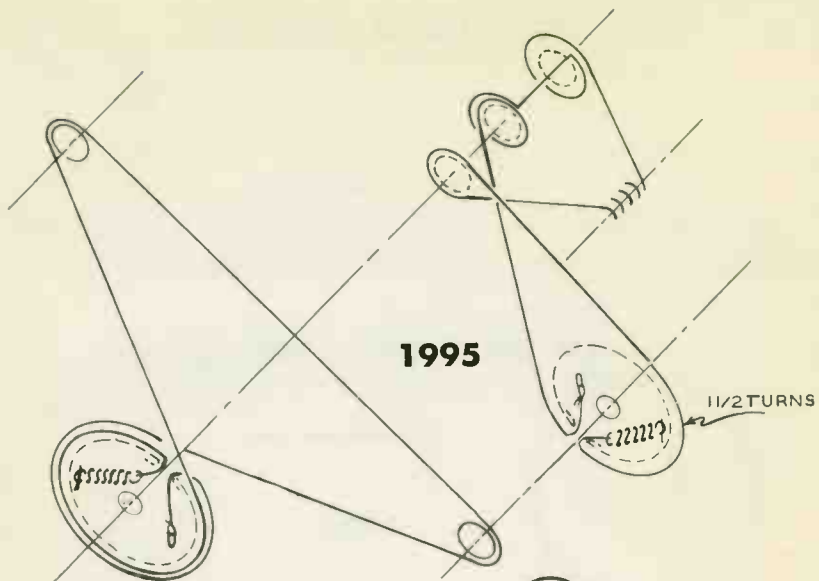

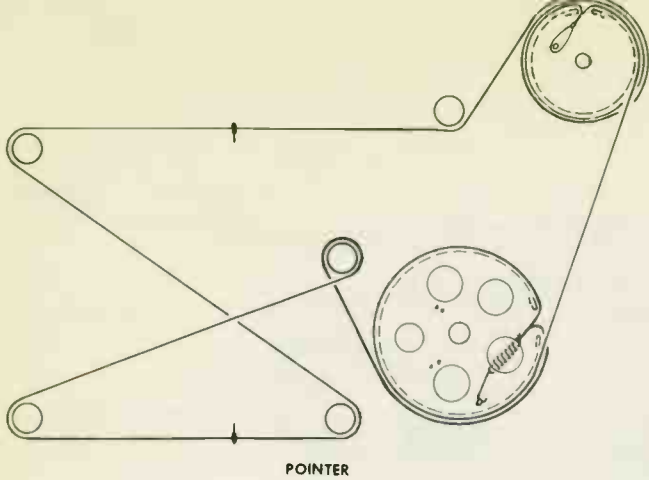

POINTER

**2000**

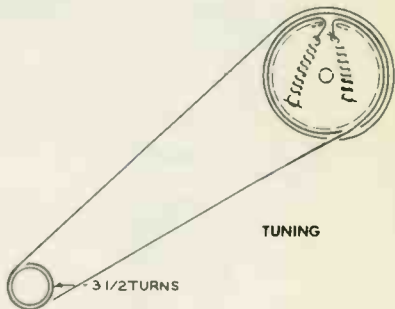

TUNING

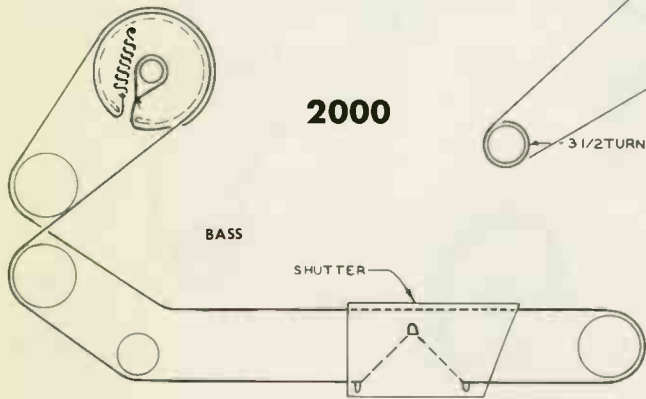

BASS

SHUTTER

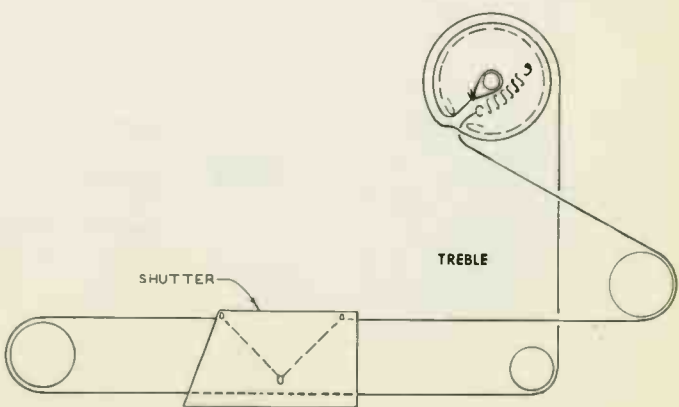

TREBLE

SHUTTER

TUNING GANG FULLY CLOSED

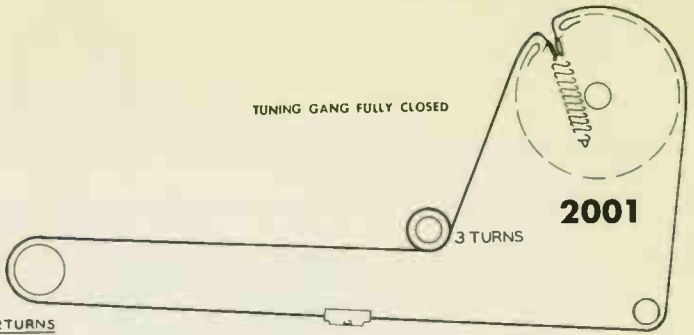

2001

3 TURNS

1 TURN 1 1/2 TURNS 3 1/2 TURNS

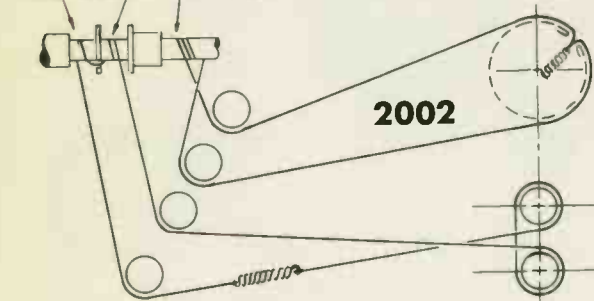

2002

TUNING GANG FULLY CLOSED

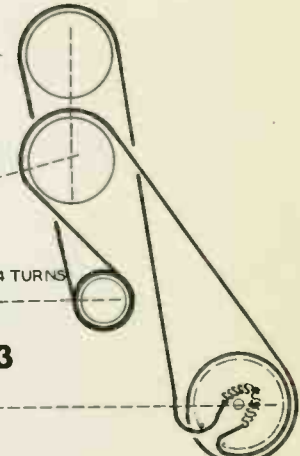
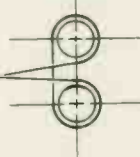

2003

3 3/4 TURNS

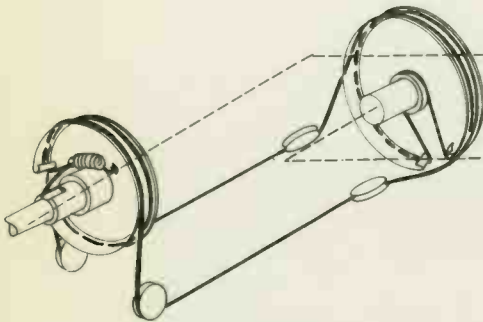

2004

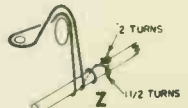
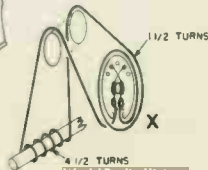
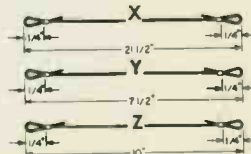
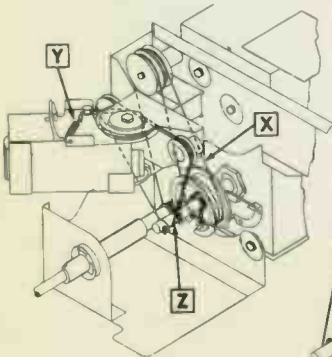

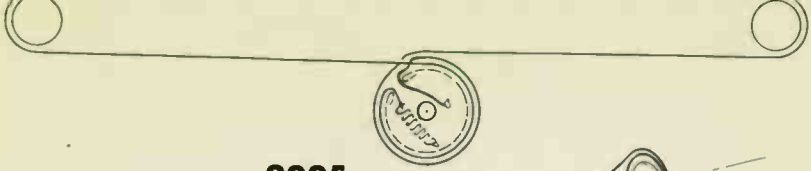

**2005**

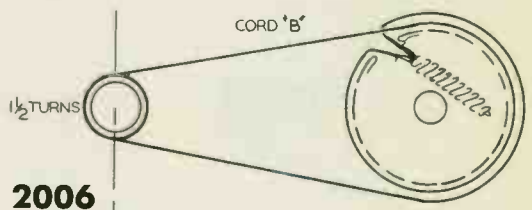
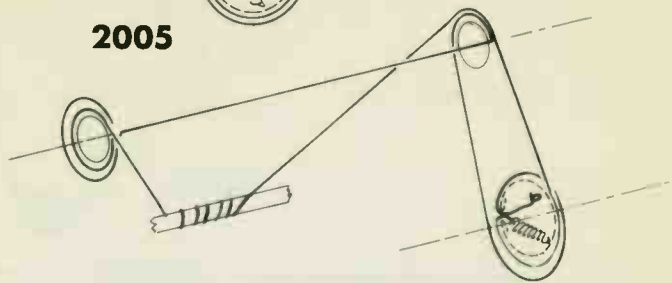

**2006**

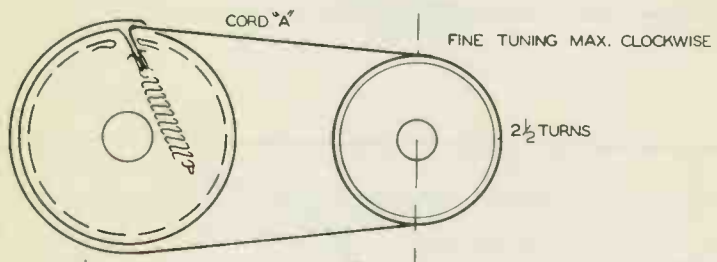

FINE TUNING MAX. CLOCKWISE



**2007**





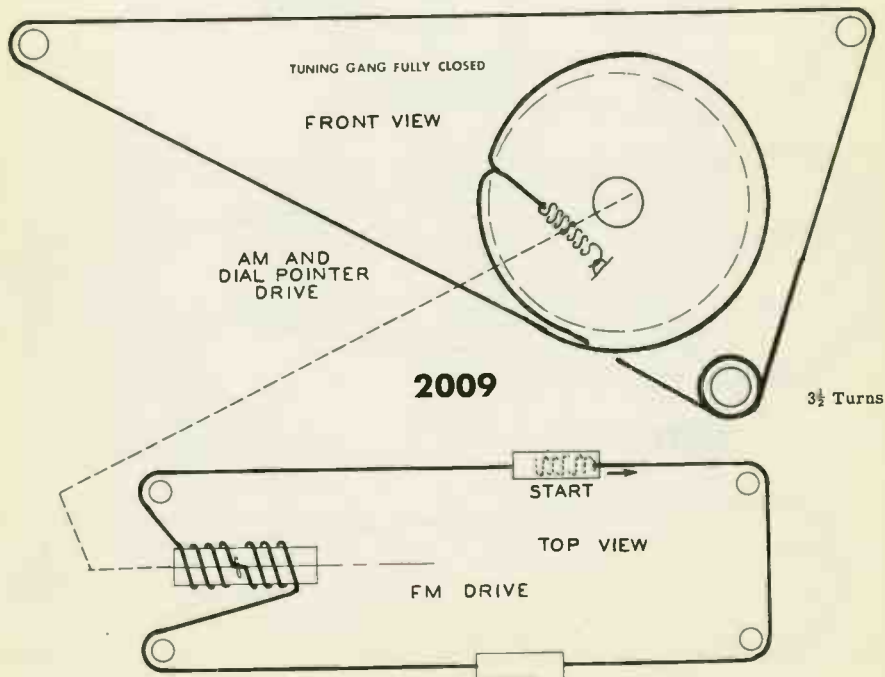
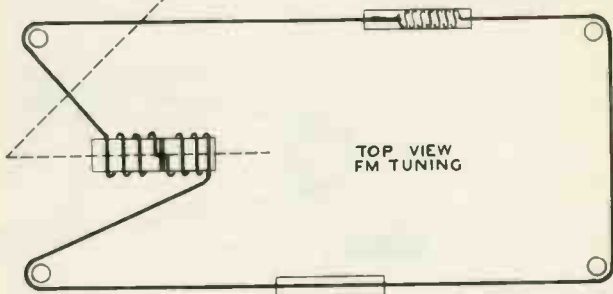
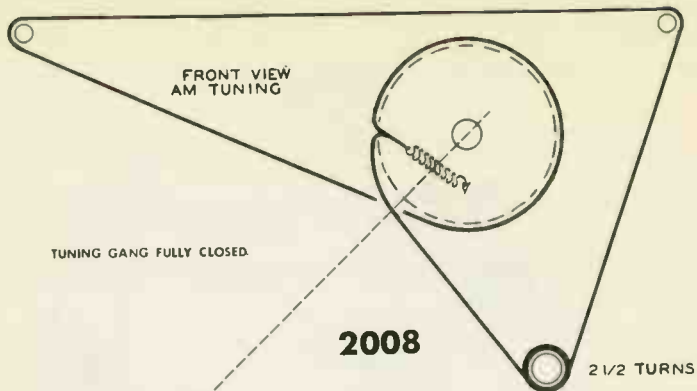

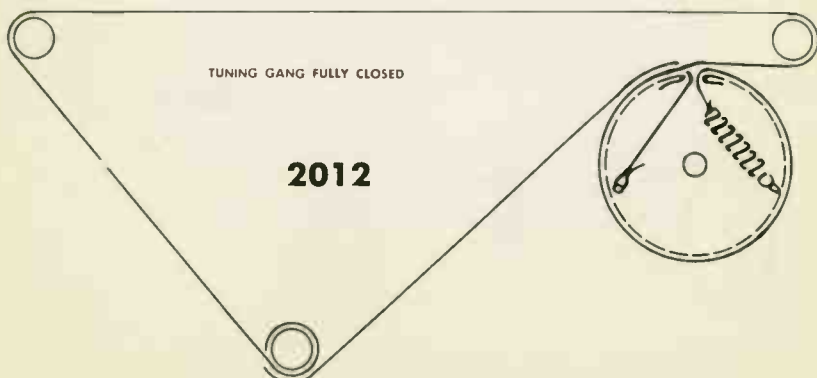
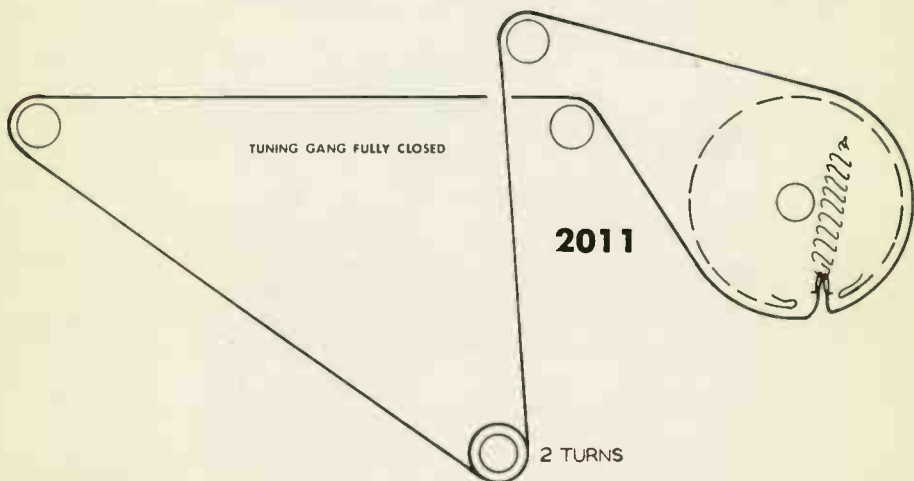
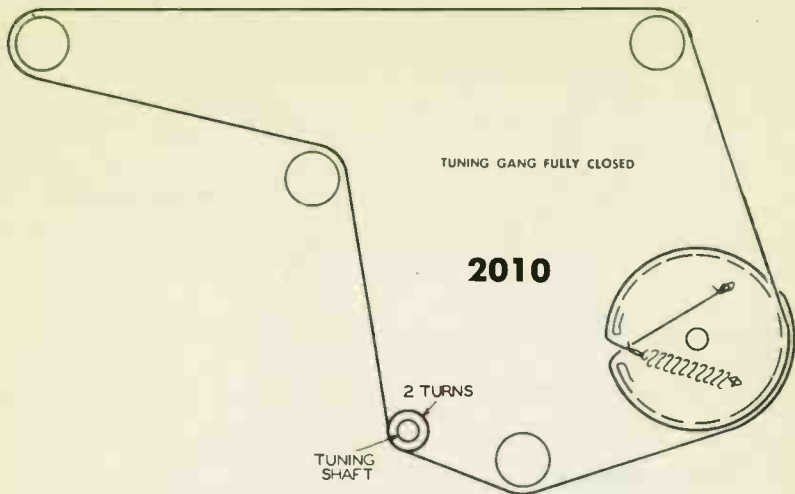

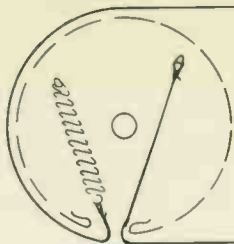

**2013**

TUNING GANG FULLY CLOSED

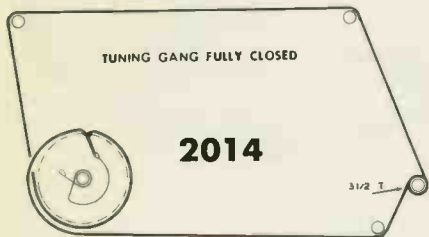

**2014**

TUNING GANG FULLY CLOSED

3/2 T

1 TURN  
TUNING SHAFT

**2015**

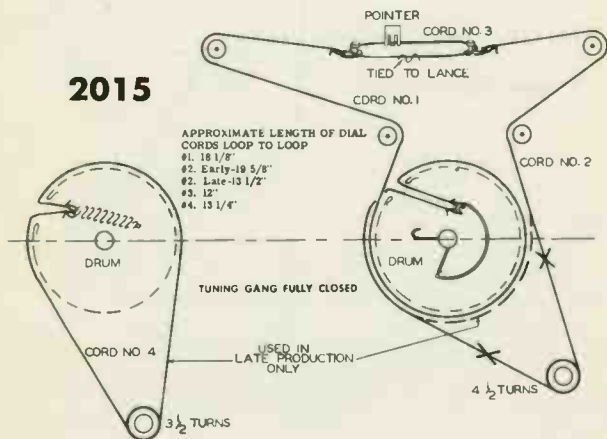

**2016**

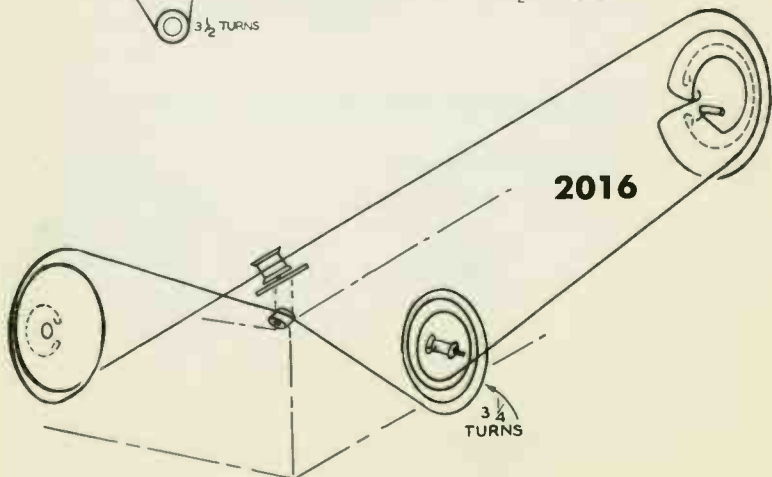

TUNING GANG FULLY CLOSED

**2017**

2 1/2 TURNS

**2018**

TUNING GANG FULLY CLOSED

3 TURNS

TUNING GANG FULLY CLOSED

**2019**

3 TURNS

**2020**

TUNING GANG FULLY CLOSED

2 1/2 TURNS

CORD #1

FIXED POINT

CORD #2

CORD #3

TUNING GANG FULLY CLOSED

**2021**

3 1/2 TURNS

CORD #4

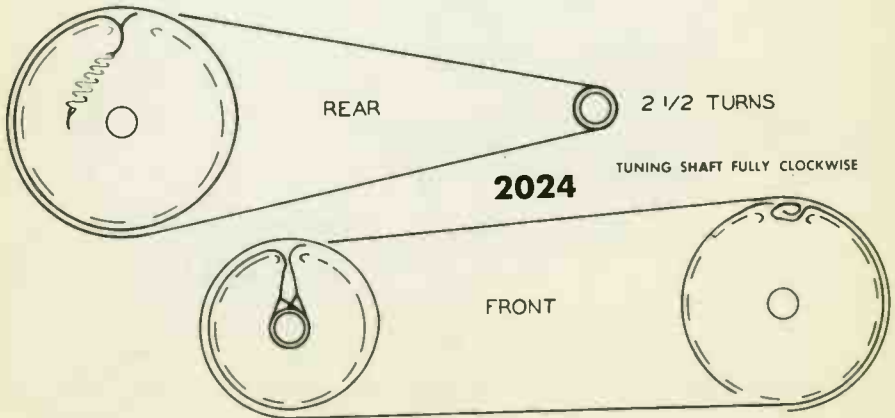
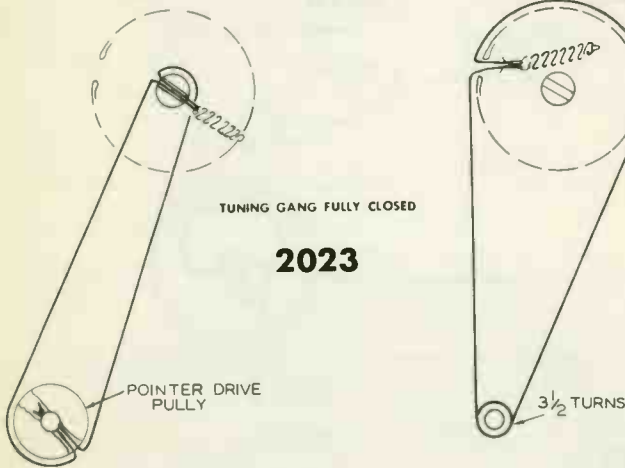
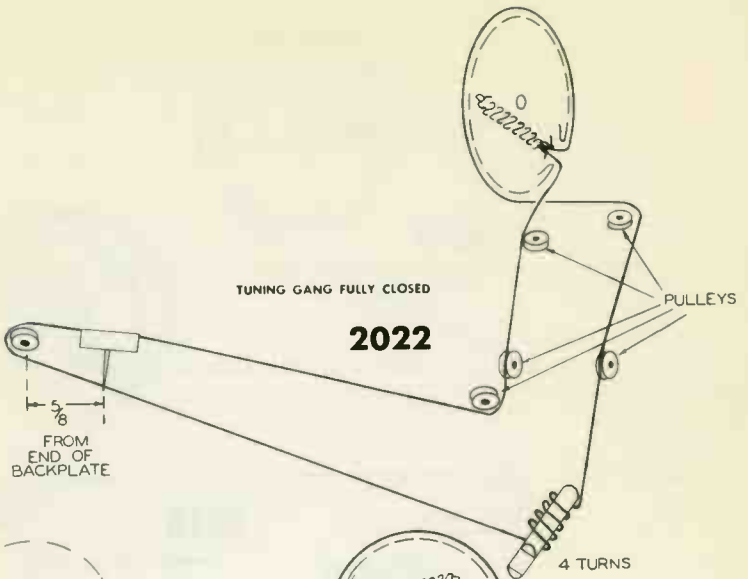

**2025**

TUNING GANG FULLY OPEN

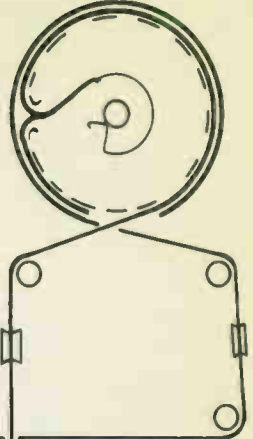

3 1/2 TURNS

2 1/2 TURNS

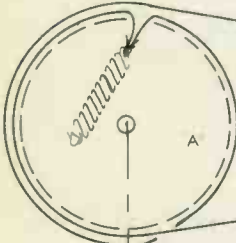

PULLEY POSITION WITH STUD AT TOP  
WHEN SHAFT 'A' IS FULLY COUNTER-  
CLOCKWISE

**2026**

2 1/2 TURNS

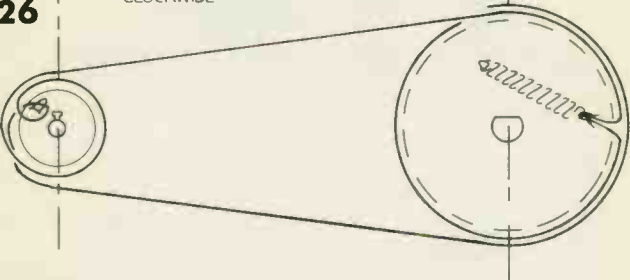

TUNING SHAFT FULLY COUNTERCLOCKWISE

**2027**

2 1/2 TURNS

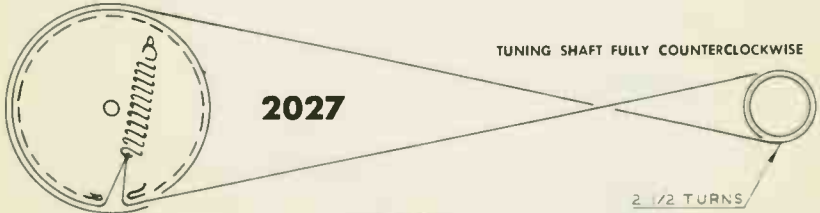

**2028**

TUNING GANG FULLY CLOSED

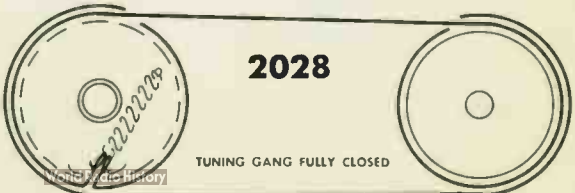

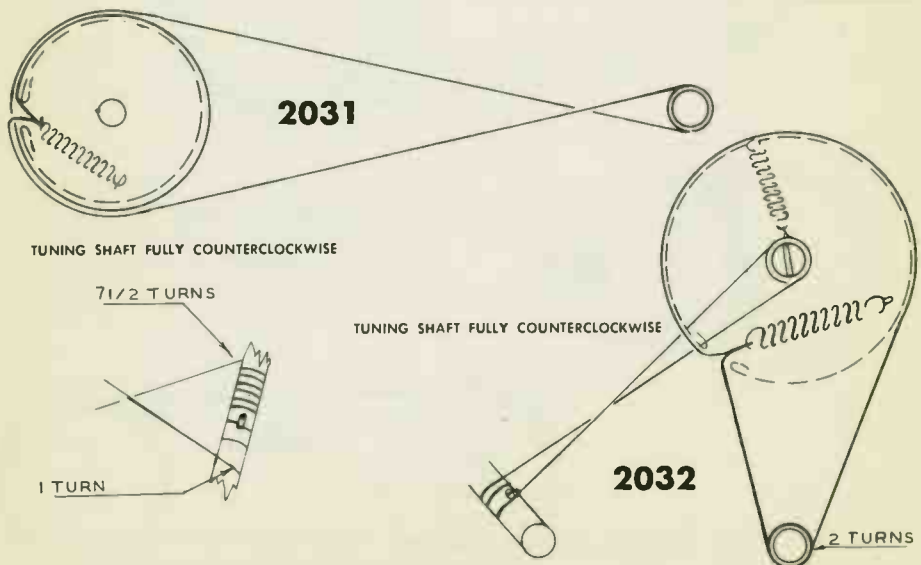
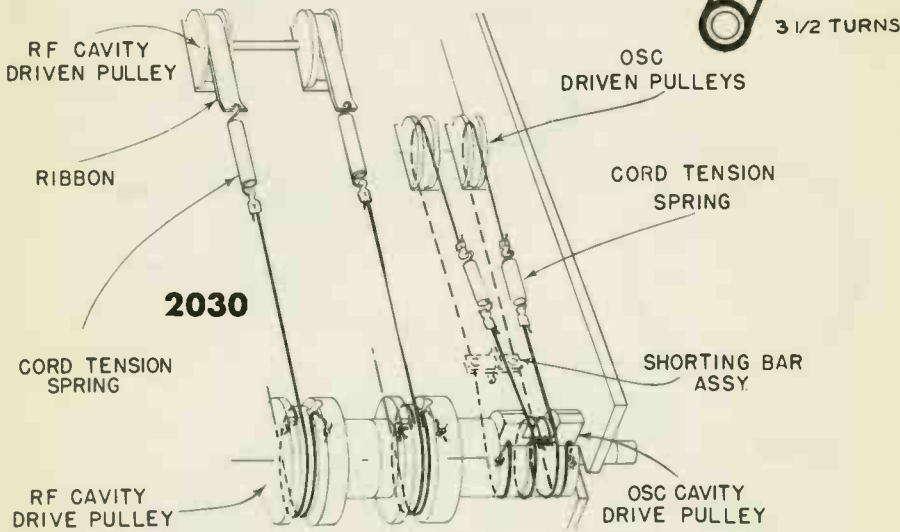
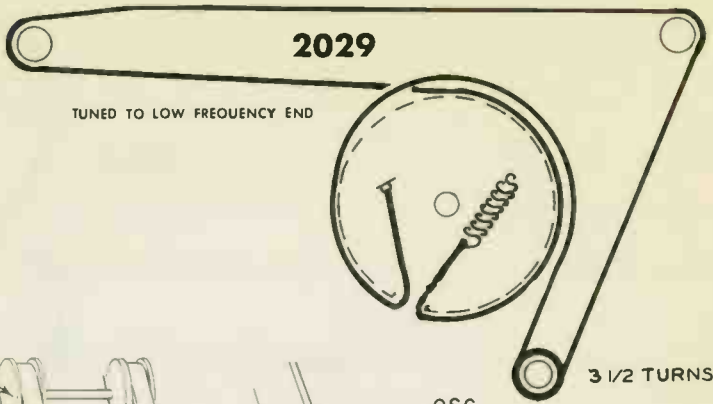

1 TURN  
AROUND  
EAR

TUNING GANG FULLY CLOSED

2033

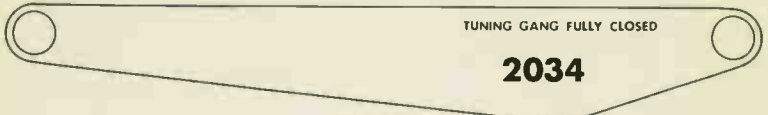

TUNING GANG FULLY CLOSED

2035

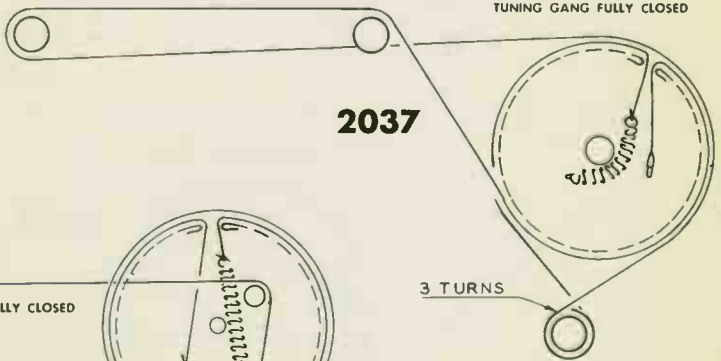



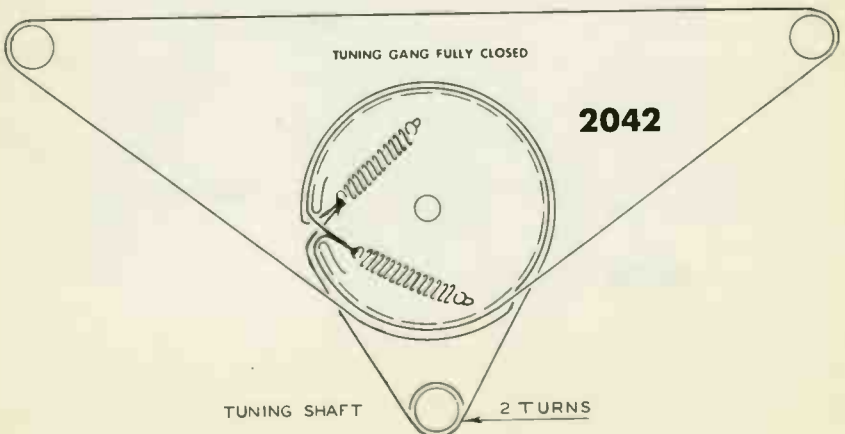
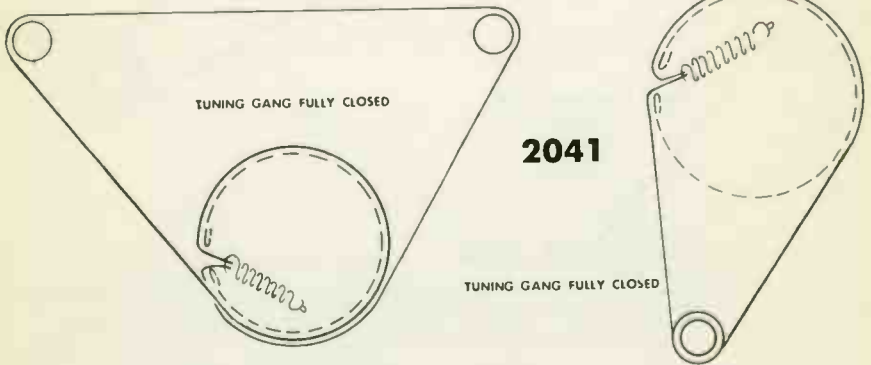
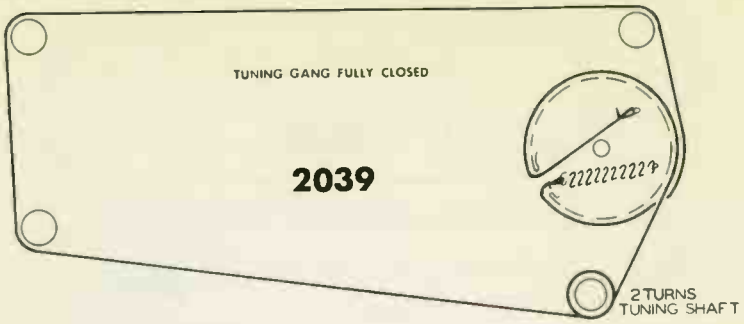

TUNING SHAFT FULLY COUNTERCLOCKWISE

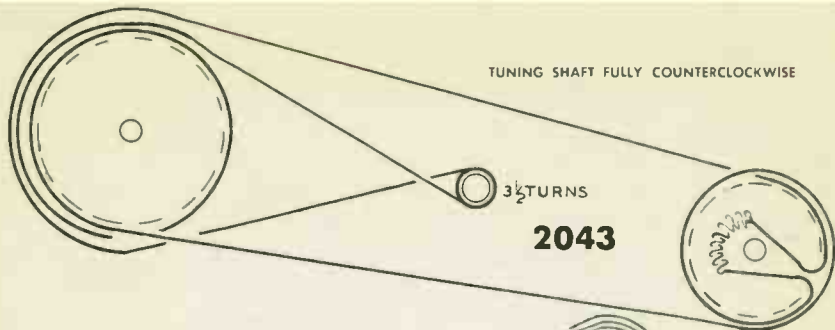

**2043**

BOTH UHF PULLEYS MUST BE IN THE EXTREME CLOCKWISE POSITION.

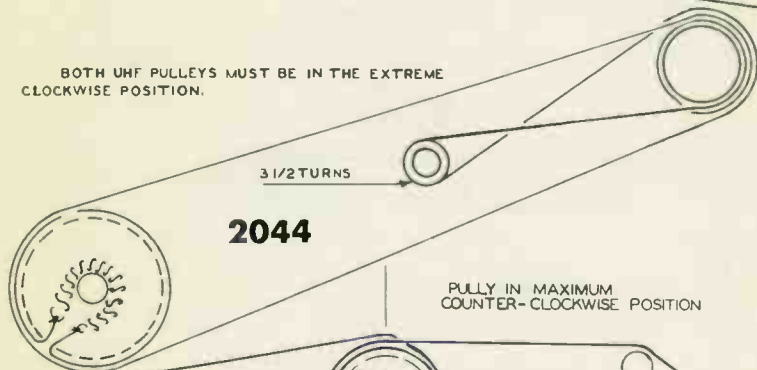

**2044**

PULLY IN MAXIMUM COUNTER-CLOCKWISE POSITION

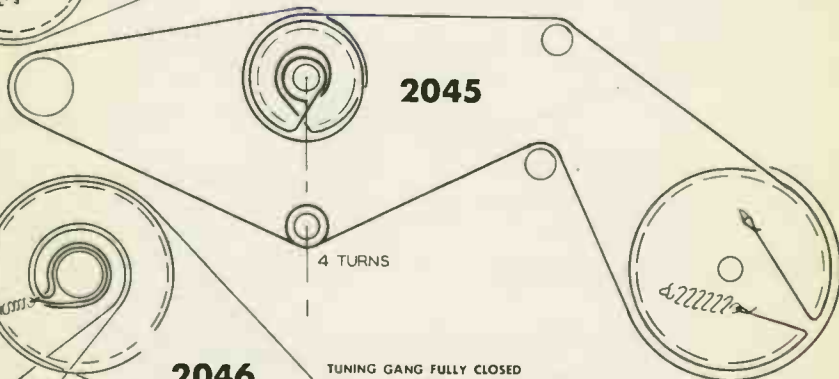

**2045**

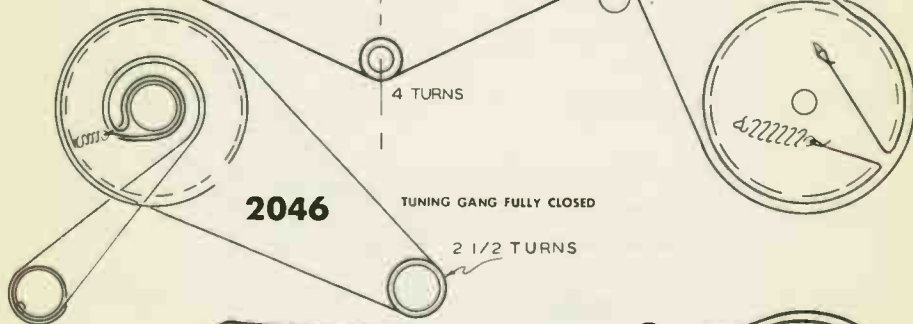

**2046**

TUNING GANG FULLY CLOSED

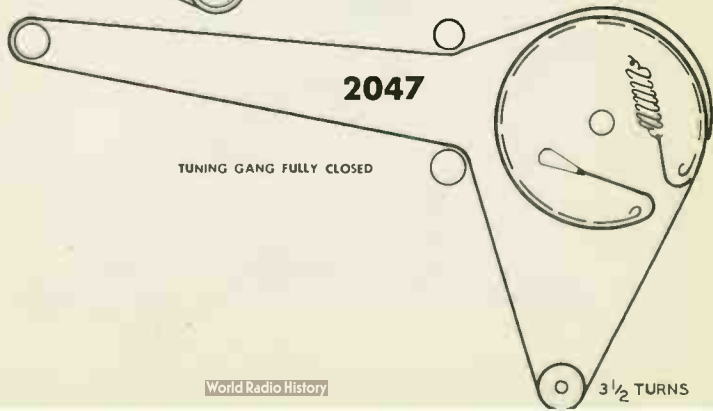

**2047**

TUNING GANG FULLY CLOSED

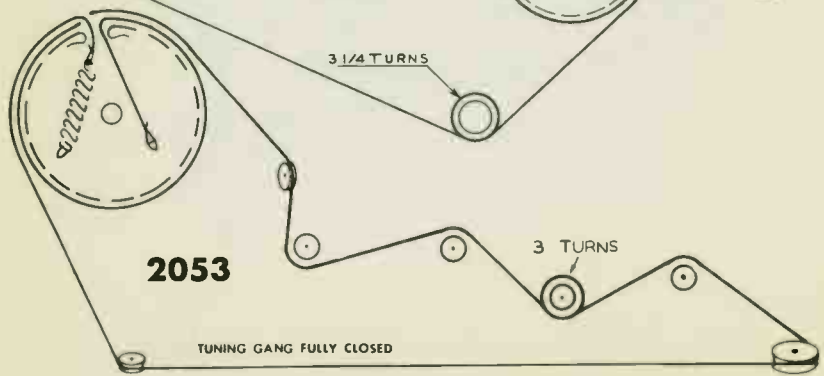
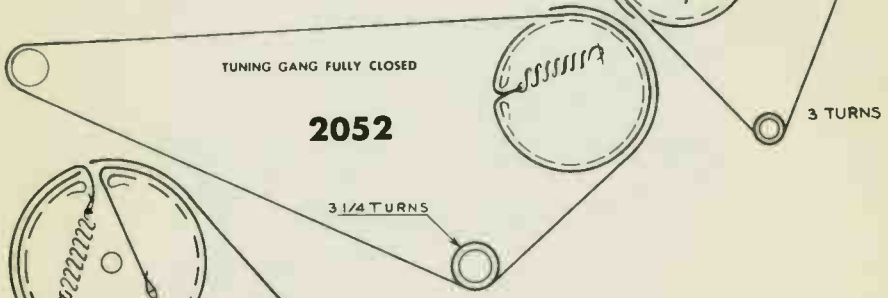
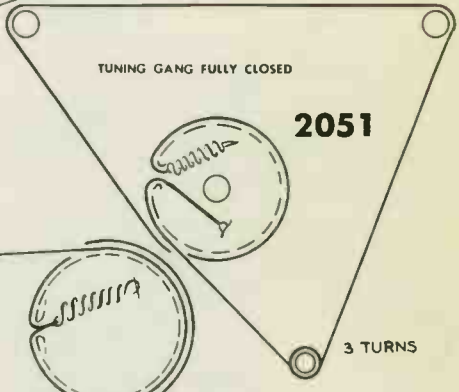
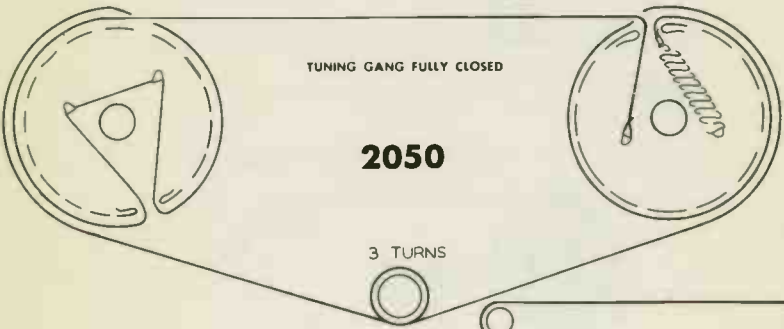
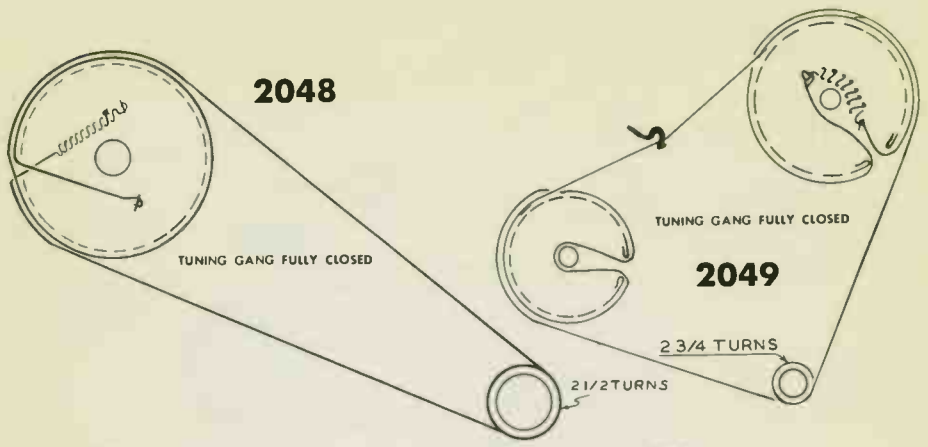

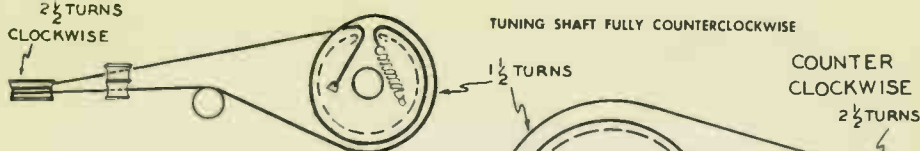

**2054**

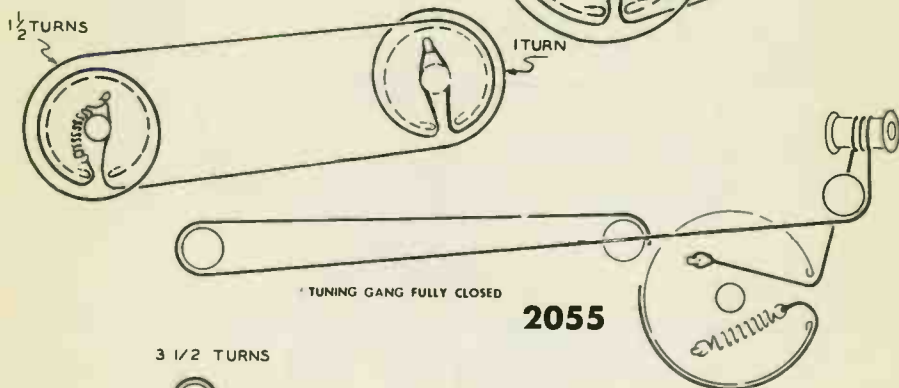

**2055**

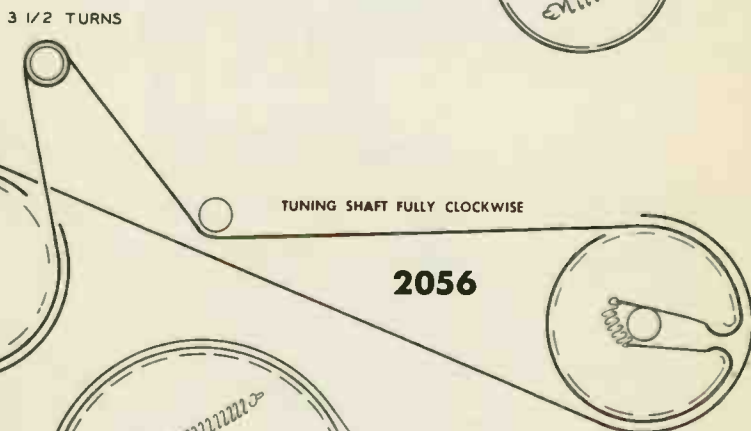

**2056**



**2057**

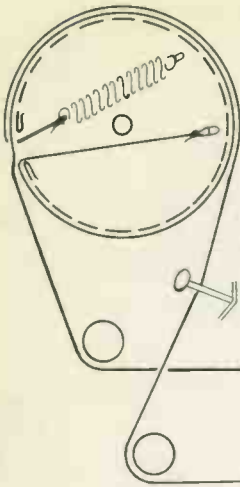

TUNING GANG FULLY CLOSED

**2058**

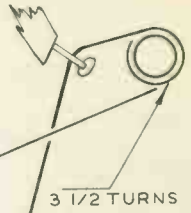

3 1/2 TURNS

TUNING GANG FULLY CLOSED

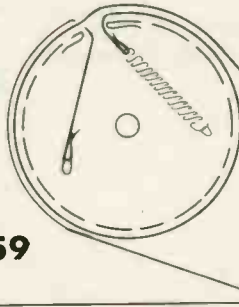

**2059**

3 1/2 TURNS

TUNING  
SHAFT

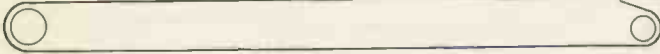

TUNING GANG FULLY CLOSED

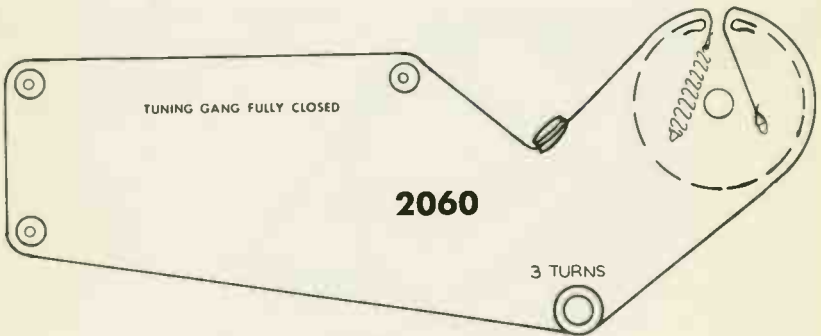

**2060**

3 TURNS

TUNING GANG FULLY CLOSED

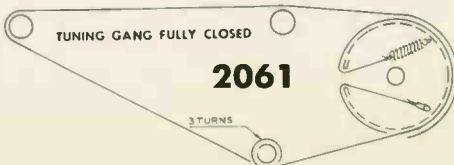

**2061**

3 TURNS

TUNING GANG FULLY CLOSED

**2062**

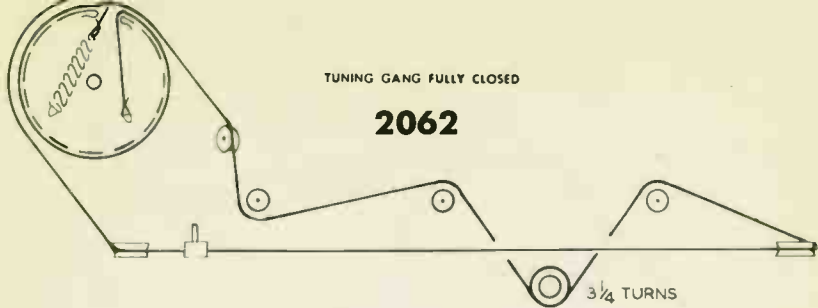

TUNING SHAFT FULLY COUNTERCLOCKWISE

**2063**

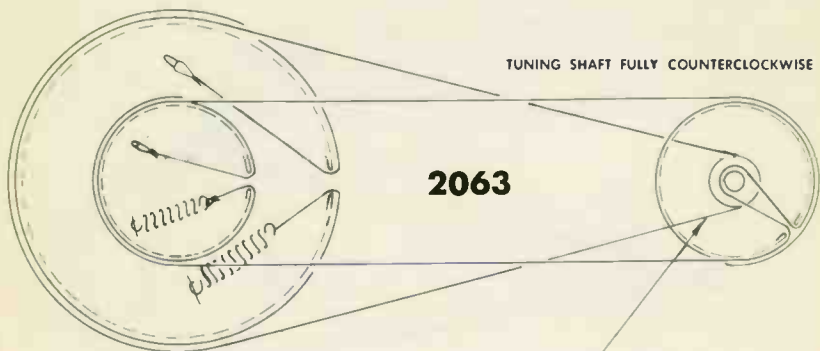

WOUND 2 1/2 TIMES AROUND SHAFT BEHIND PULLEY.

TUNING GANG FULLY CLOSED

**2064**

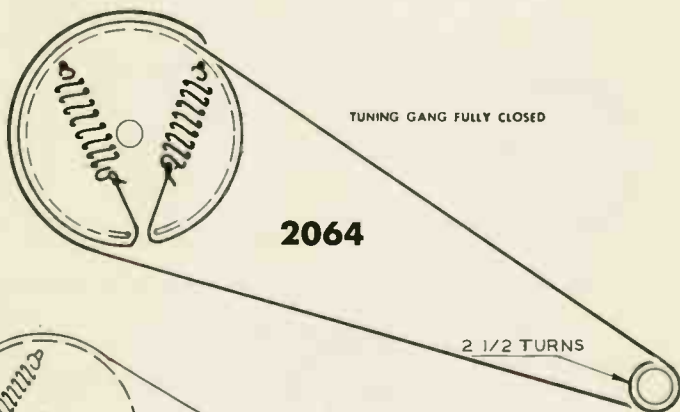

2 1/2 TURNS

**2065**

TUNING GANG FULLY CLOSED

3 1/2 TURNS

TUNING GANG FULLY CLOSED

2066

3 1/2  
TURNS

2067

TUNING GANG FULLY CLOSED

3 TURNS

TUNING SHAFT

TUNING  
SHAFT

3 TURNS

TUNING PULLEYS MAX. COUNTER CLOCKWISE

2068

BACK PULLEY

TUNING GANG FULLY CLOSED

2069

FRONT  
PULLEY

2 1/2 TURNS

TUNING SHAFT

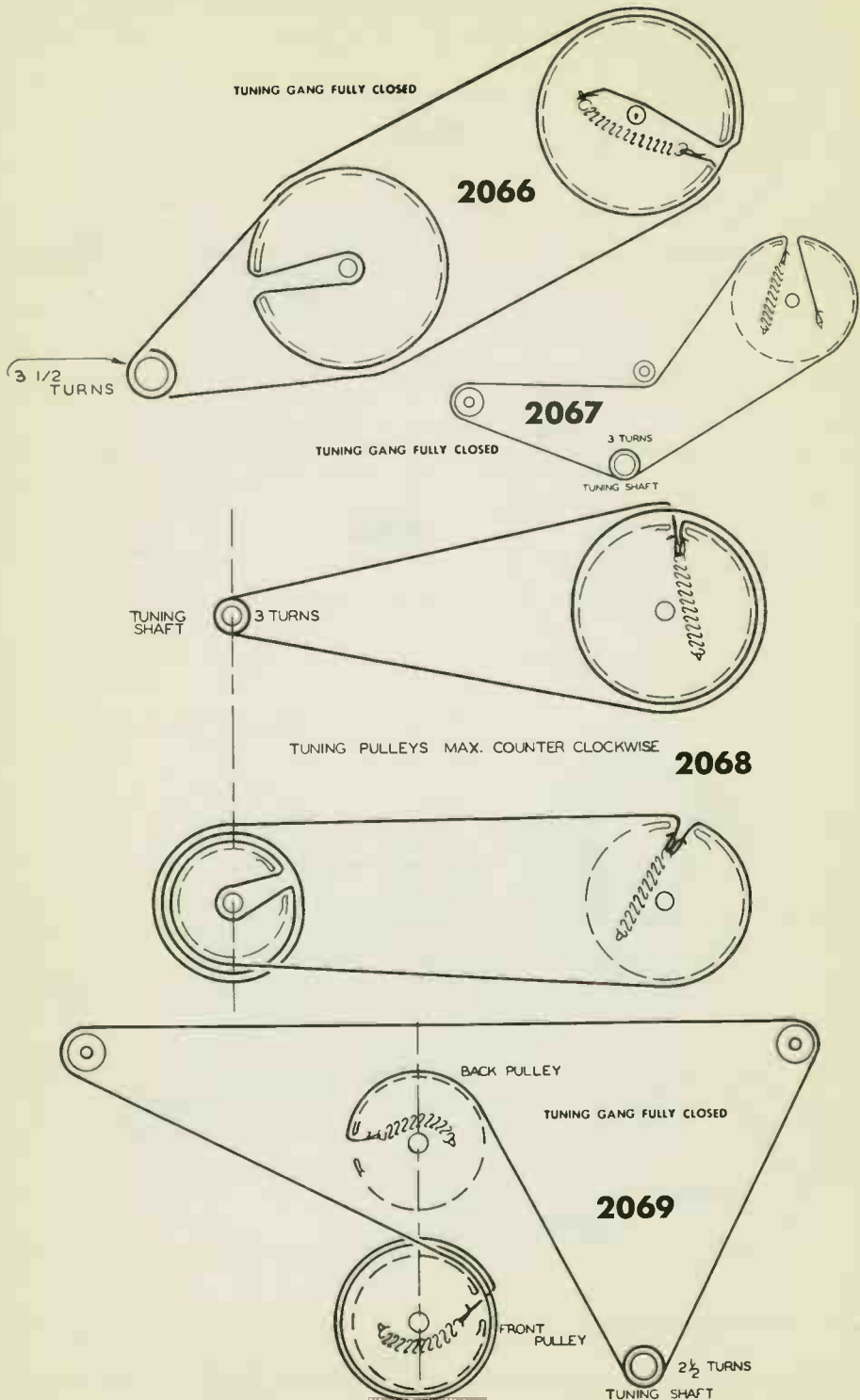

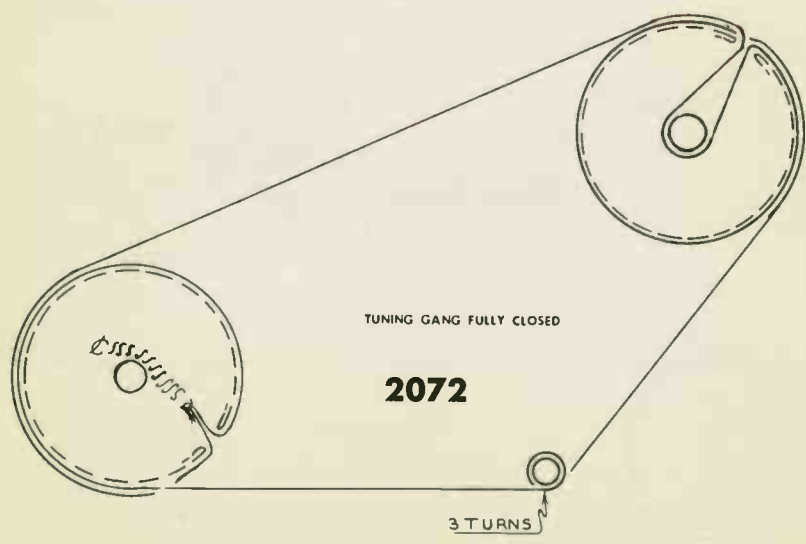
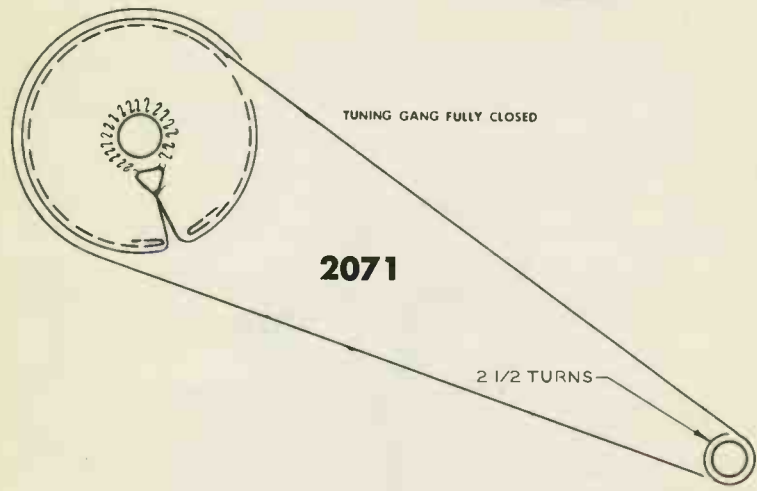
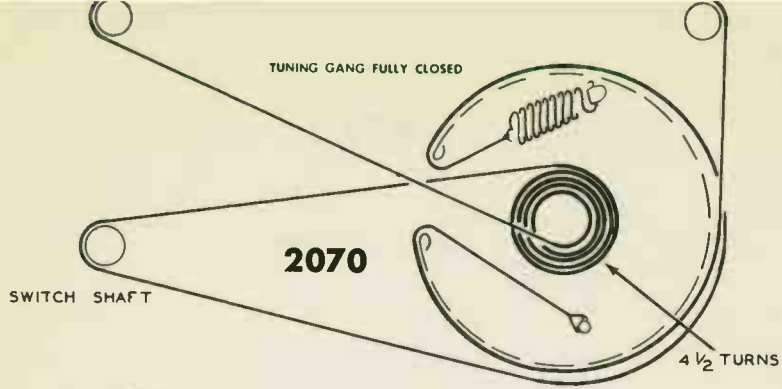





**2073**

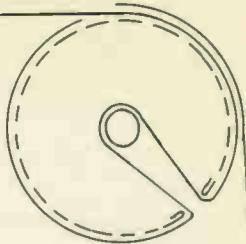

TUNING GANG FULLY CLOSED

2 1/2 TURNS

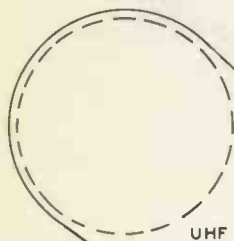

UHF TUNING  
(REAR)

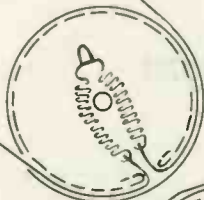

**2074**

UHF TUNING  
(FRONT)



TUNING DIAL FULLY  
COUNTERCLOCKWISE

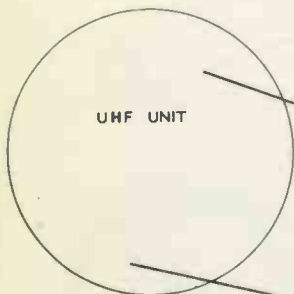

UHF UNIT



TUNING CONTROL FULLY  
COUNTERCLOCKWISE



**2075**



**2076**



TUNING GANG FULLY CLOSED

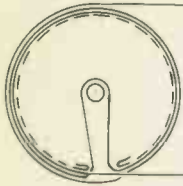

**2077**

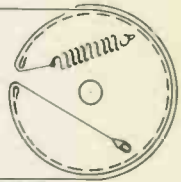

TUNING GANG FULLY CLOCKWISE

**2078**

TUNING GANG FULLY CLOSED

4 TURNS

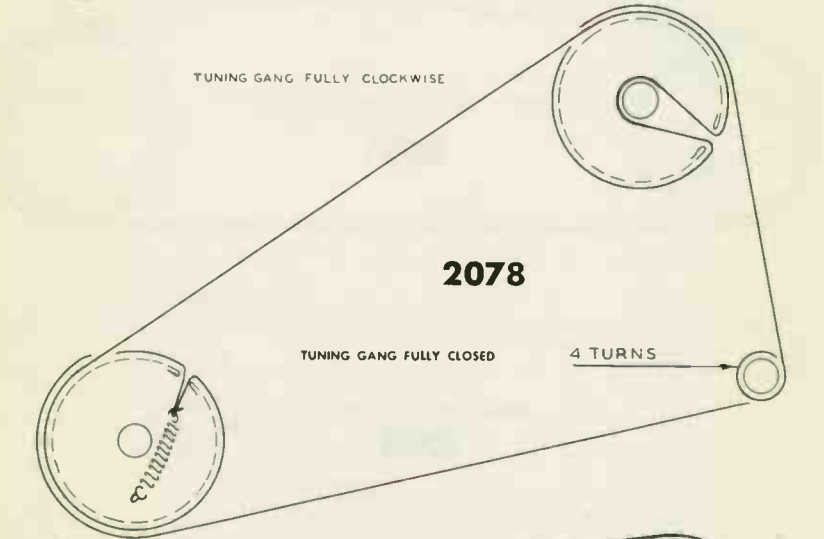

TUNING GANG FULLY CLOSED

**2079**

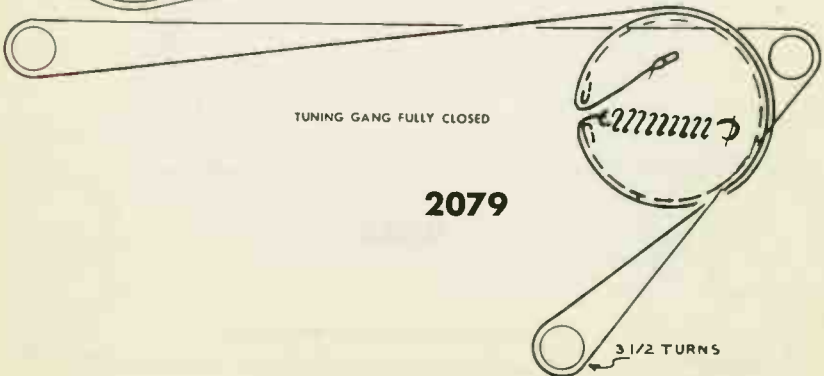

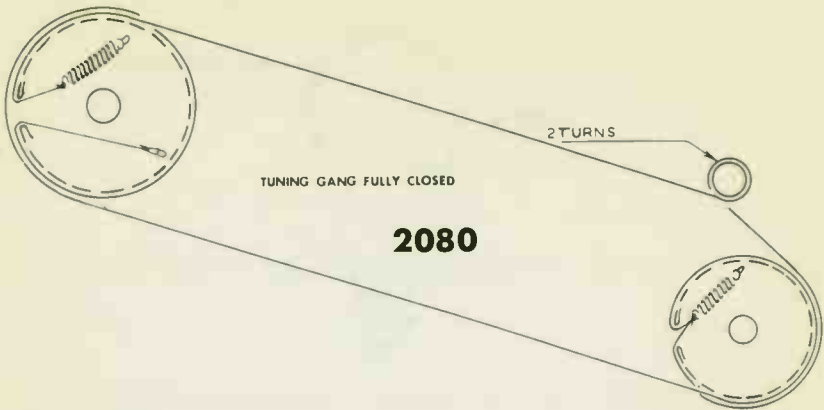

**2080**

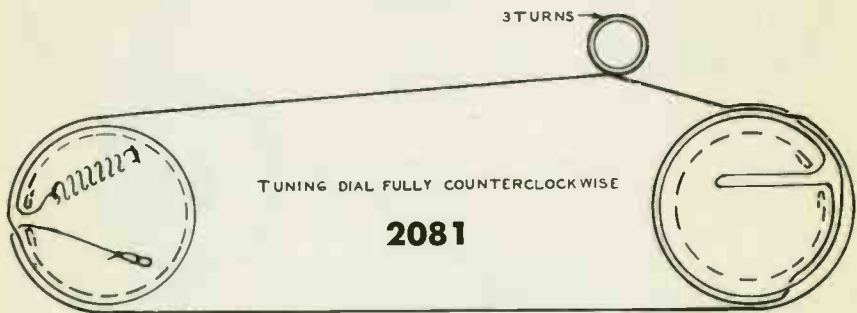

**2081**

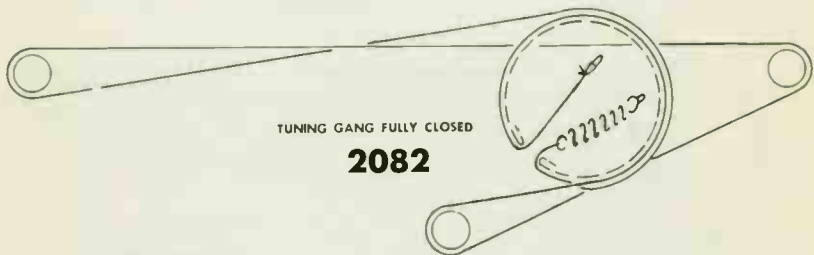

**2082**

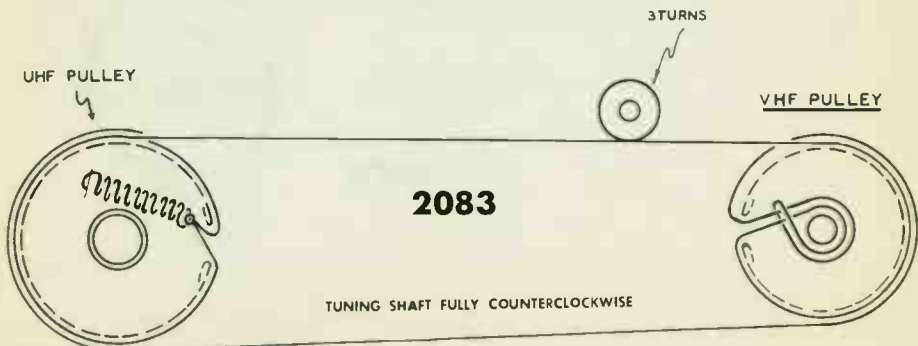

**2083**

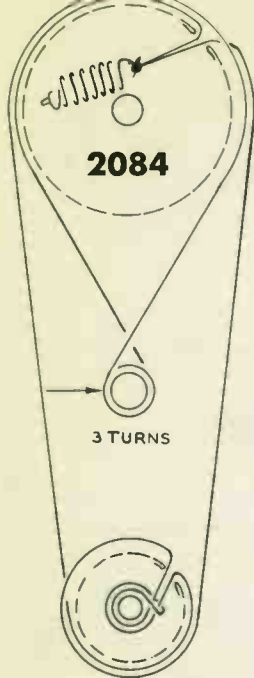

**2084**

3 TURNS

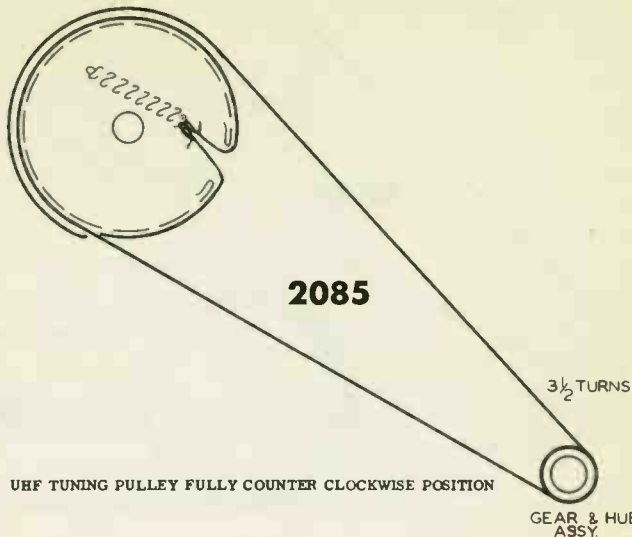

**2085**

3 1/2 TURNS

GEAR & HUB ASSY

UHF TUNING PULLEY FULLY COUNTER CLOCKWISE POSITION

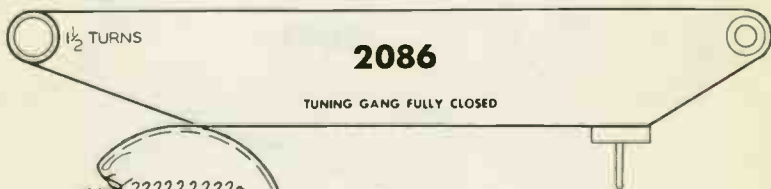

**2086**

TUNING GANG FULLY CLOSED

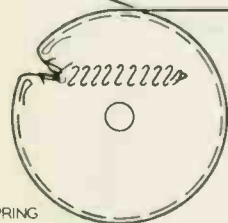

**2087**

TUNING GANG FULLY CLOSED

METAL TENSION SPRING

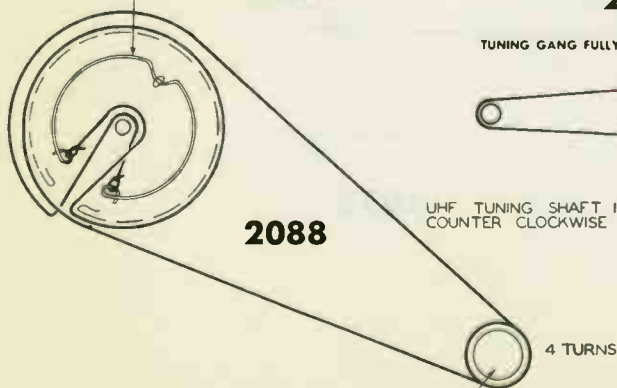

**2088**

4 TURNS

UHF TUNING SHAFT IN MAX. COUNTER CLOCKWISE POSITION

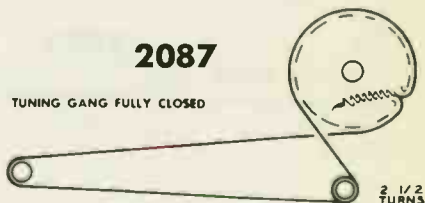

2 1/2 TURNS

TUNING GANG FULLY CLOSED

**2089**

3½ TURNS

TUNING SHAFT

TUNING GANG FULLY CLOSED

**2090**

3 TURNS  
TUNING SHAFT

TUNING GANG FULLY CLOSED

**2091**

TUNING GANG FULLY CLOSED

**2092**

3½ TURNS

TUNING GANG FULLY CLOSED

**2093**

2 TURNS

2 1/2 TURNS

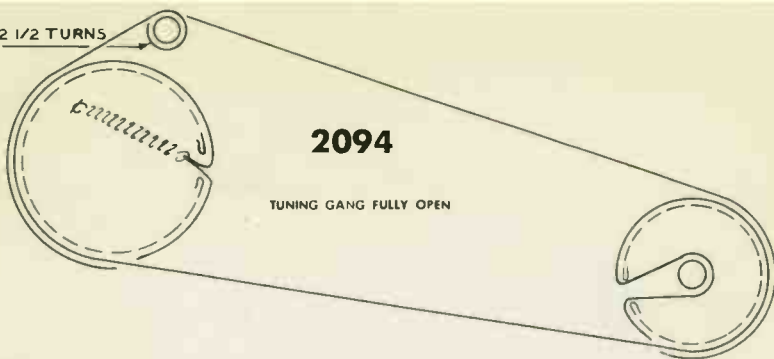

**2094**

TUNING GANG FULLY OPEN

TUNING GANG FULLY CLOSED

**2095**

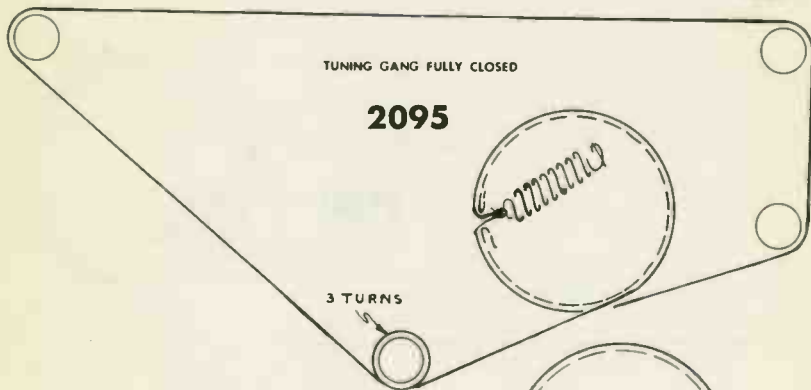

3 TURNS

TUNING GANG FULLY CLOSED

**2096**

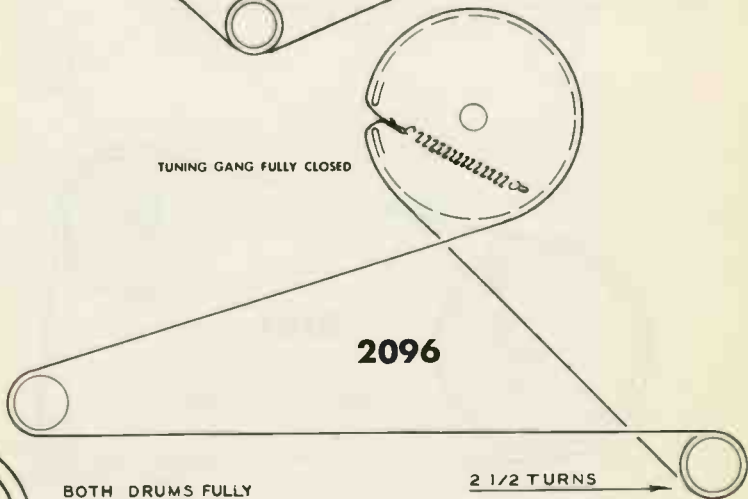

2 1/2 TURNS

**2097**

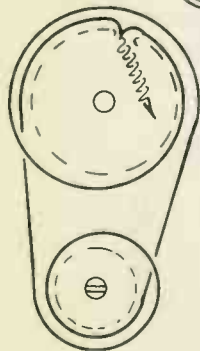

BOTH DRUMS FULLY  
COUNTERCLOCKWISE

TUNING GANG FULLY CLOSED

**2098**

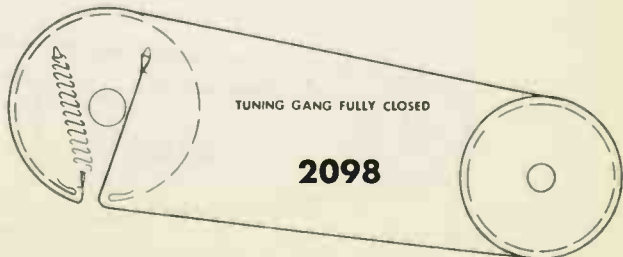

1 1/2 TURNS

TURN DRUM COMPLETELY COUNTER-CLOCKWISE

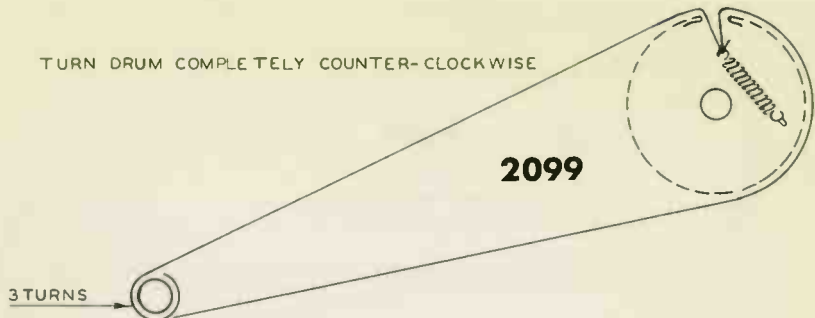

TUNING GANG FULLY CLOSED

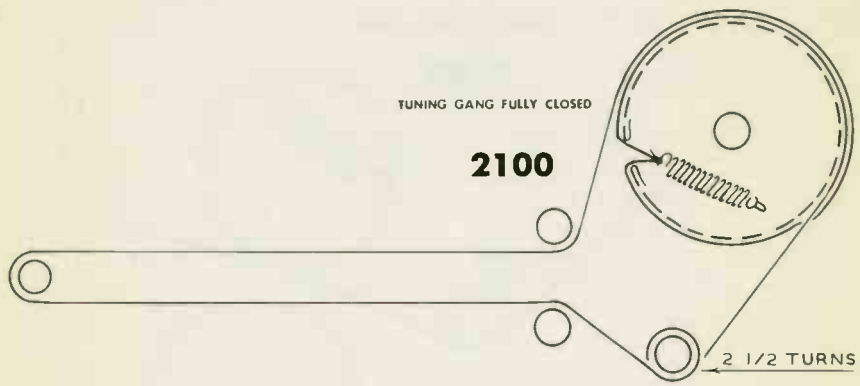

TUNING GANG FULLY  
PULLY

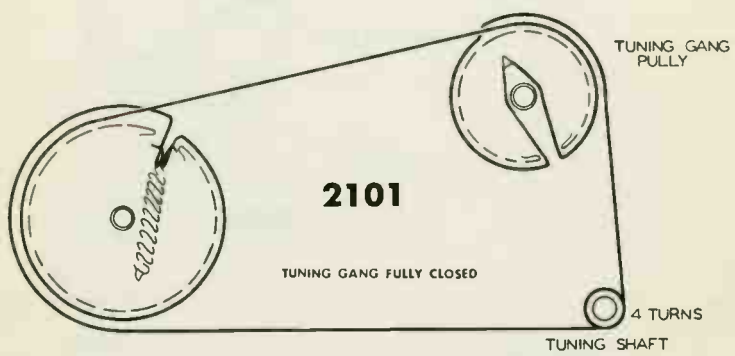

TUNING GANG FULLY CLOSED

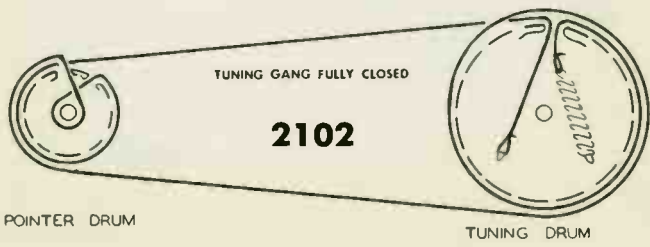

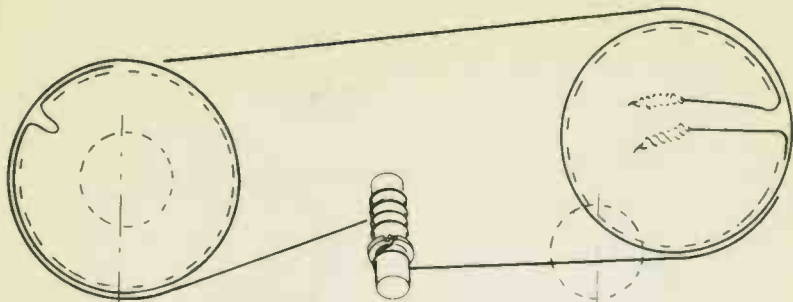

**2103**

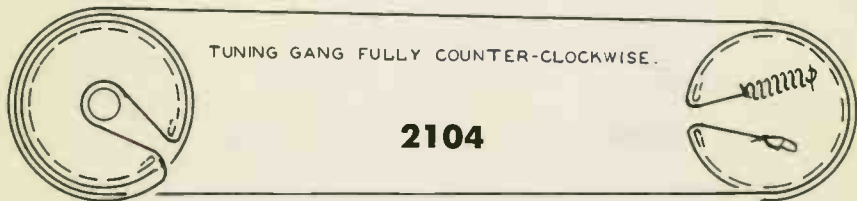
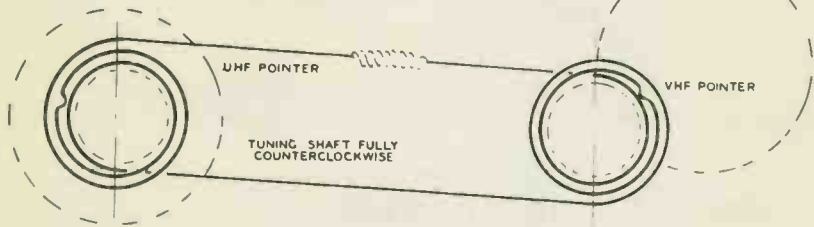

TUNING GANG FULLY COUNTER-CLOCKWISE.

**2104**

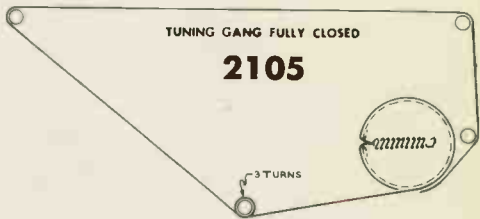

TUNING GANG FULLY CLOSED

**2105**

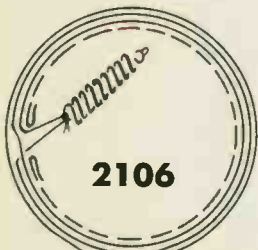

**2106**

TUNING GANG FULLY CLOSED



3 TURNS



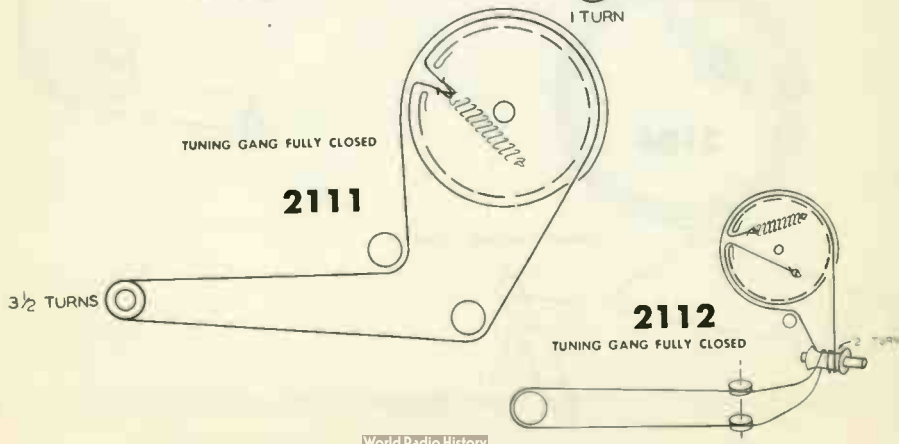
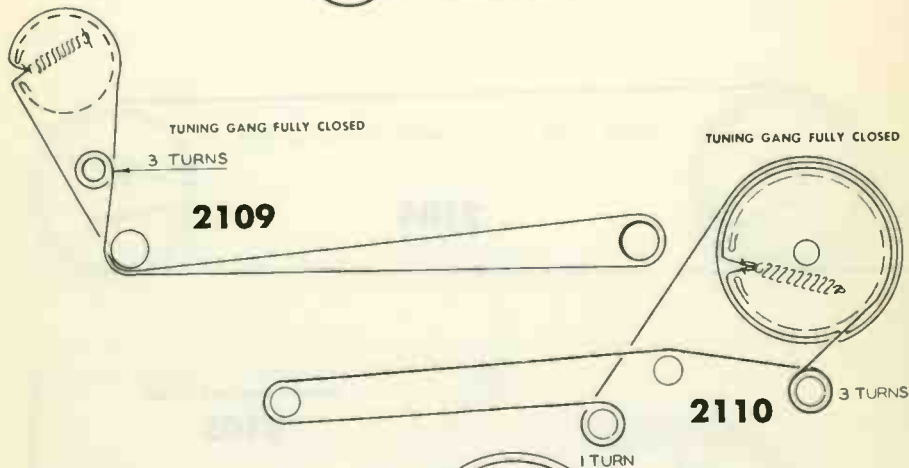
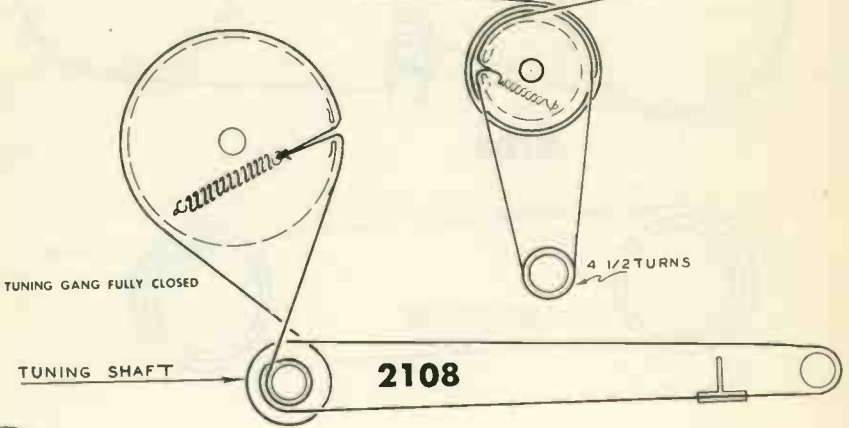
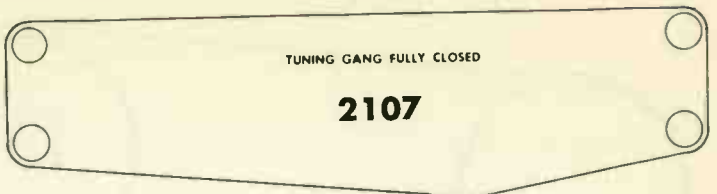

(FM TUNING SLUGS FULLY IN)  
 FM  
 KNOT  
 RIVET

**2113**

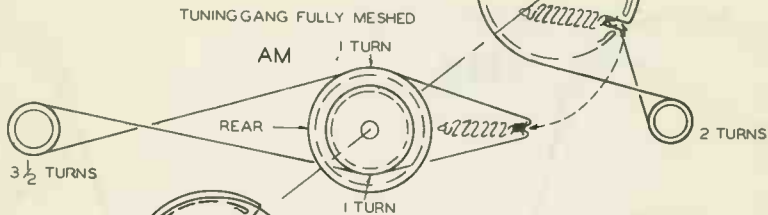

**2114**

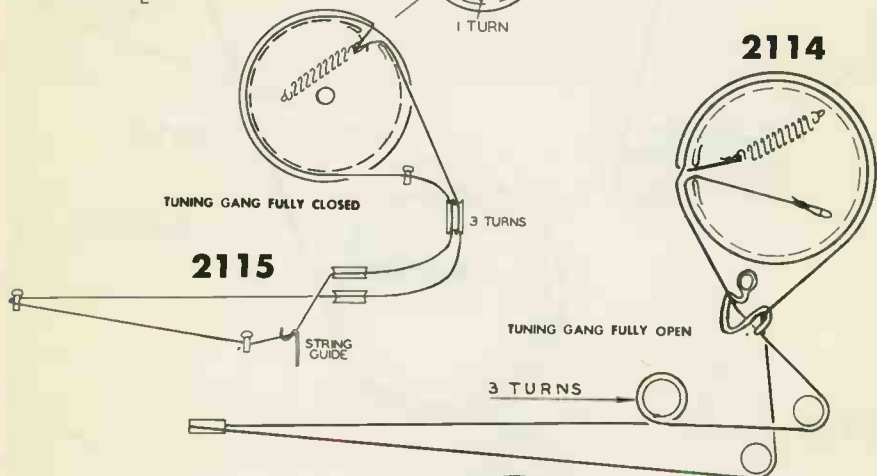

**2115**

TUNING GANG FULLY CLOSED

**2116**

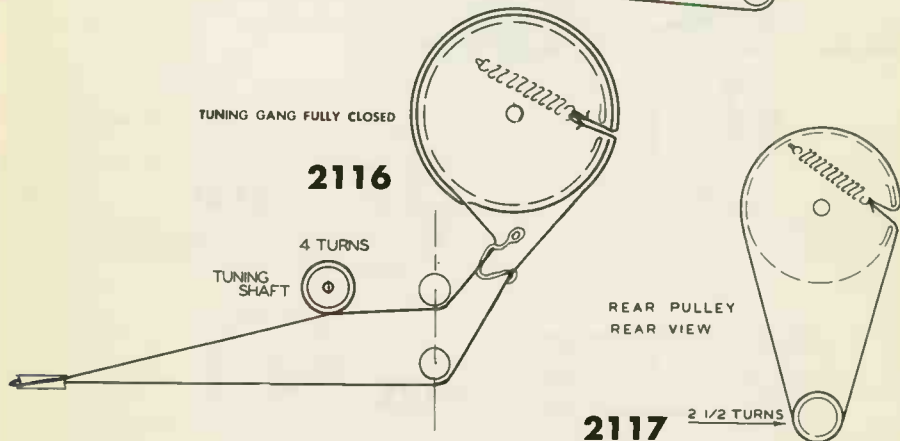

**2117**



TUNING GANG FULLY COUNTERCLOCKWISE.

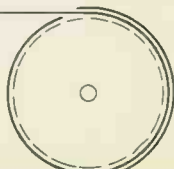

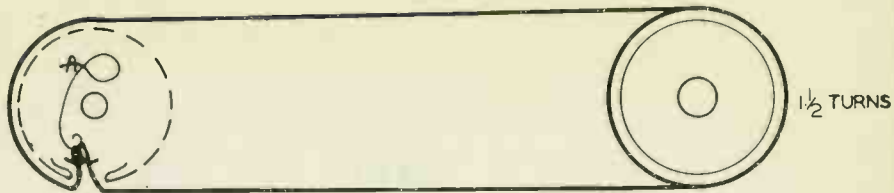

TUNING GANG FULLY CLOSED

**2118**

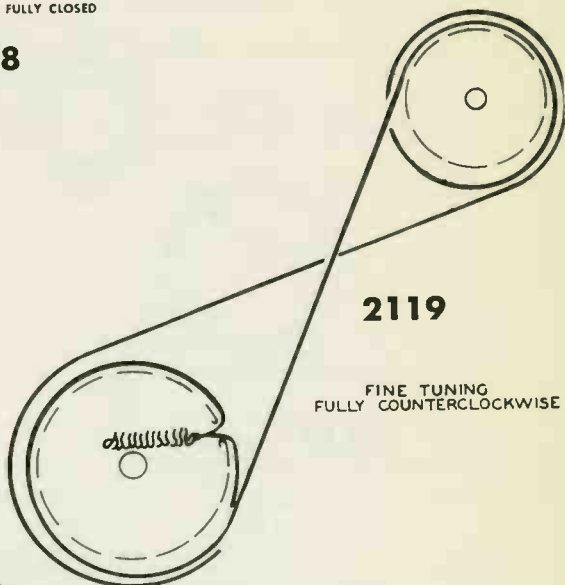
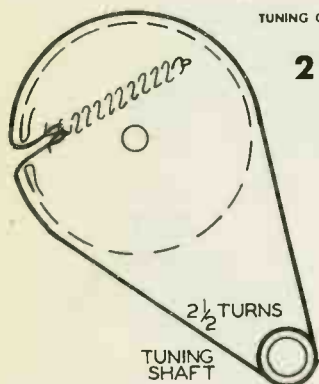

**2119**

FINE TUNING  
FULLY COUNTERCLOCKWISE

**2120**

TUNING GANG FULLY CLOSED.

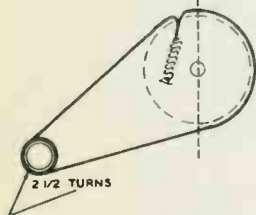
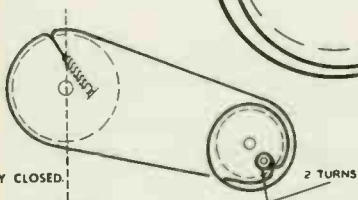

TUNING GANG FULLY CLOSED

**2121**

CORD OVER SHAFT &  
1 1/2 TURNS AROUND PULLEY

**2122**

TUNING GANG FULLY CLOSED

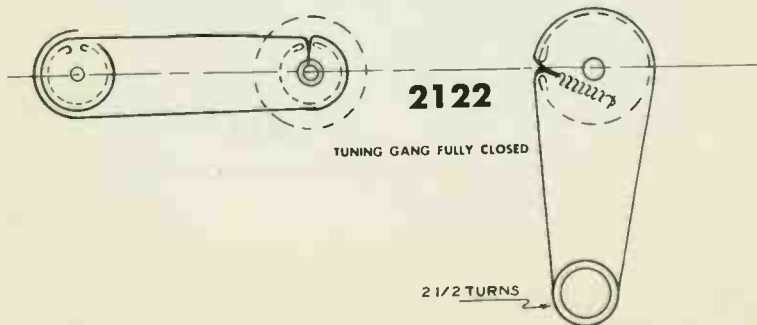

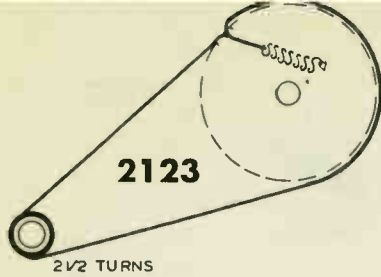

**2123**

2 1/2 TURNS

TUNING GANG FULLY CLOSED

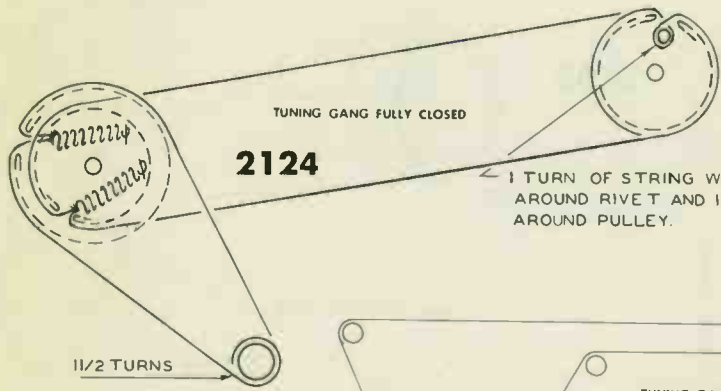

**2124**

1 1/2 TURNS

TUNING GANG FULLY CLOSED

1 TURN OF STRING WRAPPED AROUND RIVET AND 1 1/2 TURNS AROUND PULLEY.

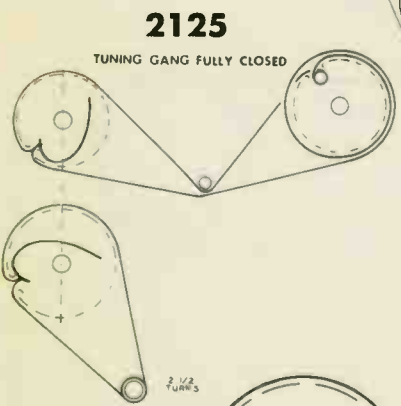

**2125**

TUNING GANG FULLY CLOSED

2 1/2 TURNS

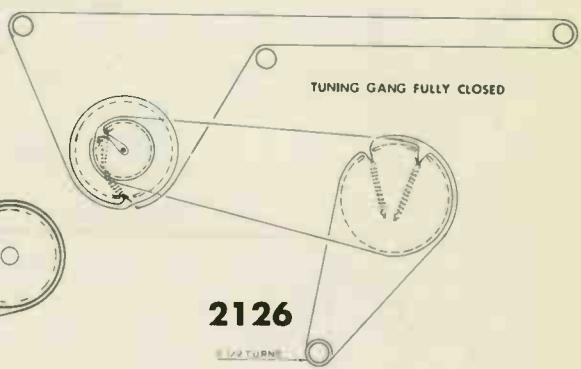

**2126**

1 1/2 TURNS

TUNING GANG FULLY CLOSED



**2127**

TUNING GANG FULLY CLOSED.



**2128**

TUNING GANG FULLY CLOSED

2 1/2 TURNS

TUNING SHAFT FULLY CLOCKWISE

**2129**

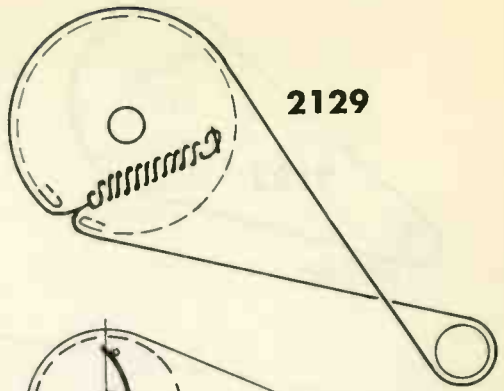

**2130**

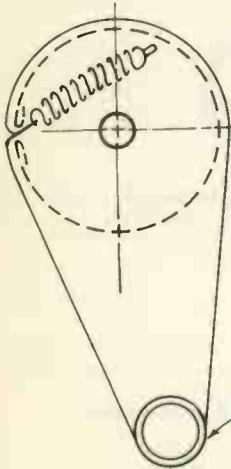

SHAFT SHOWN IN FULL COUNTERCLOCKWISE ROTATION

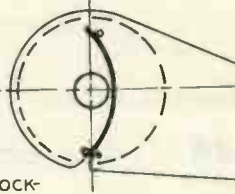

1 1/2 TURNS

TUNING GANG FULLY CLOSED

**2131**

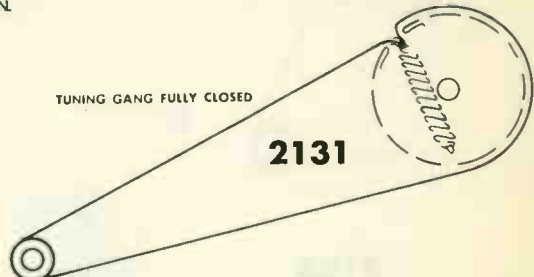

2 1/2 TURNS

TUNING GANG FULLY CLOSED

**2132**

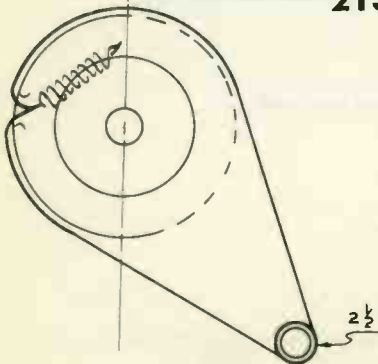
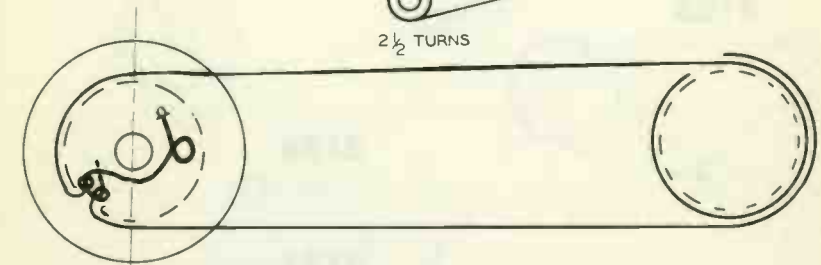

2 1/2 TURNS

FINE TUNING IN MAX COUNTER  
CLOCKWISE POSITION.

**2133**

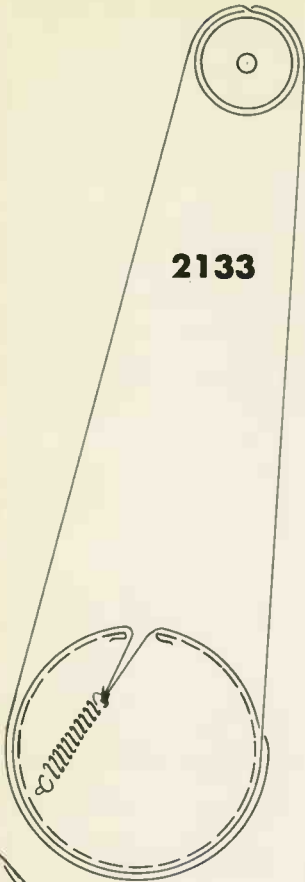

**2134**

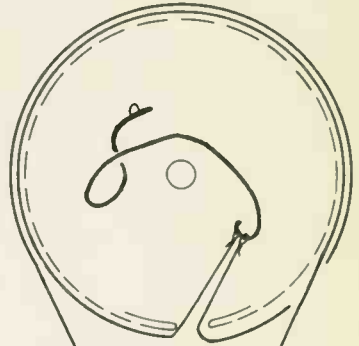

$\frac{1}{2}$  TURNS AROUND PULLEY  
AND ONE TURN  
AROUND RIVET

$\frac{1}{2}$  TURN

$\frac{1}{2}$  TURNS ON STUD

**2135**

TUNING GANG FULLY CLOSED

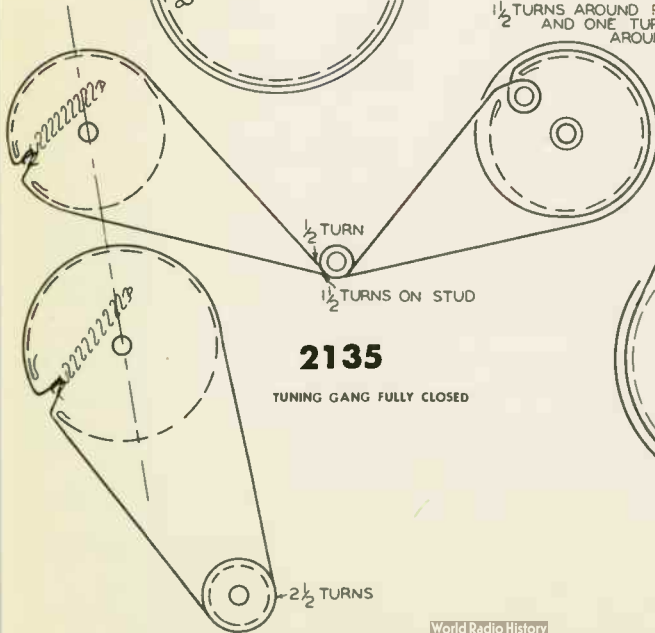

$2\frac{1}{2}$  TURNS







