



TAB BOOKS

BASIC RADIO COURSE

Enlarged & Revised Edition

by John T. Frye

BASIC RADIO COURSE

by

JOHN T. FRYE



Gernsback Library No. 44

PUBLISHED BY
GERNSBACK LIBRARY, INC.
New York, N. Y.

COPYRIGHT, 1951

B y H U G O G E R N S B A C K

All Rights Reserved

First Printing — July, 1951
Second Printing -- September, 1952
Third Printing — August, 1955
Fourth Printing — April, 1957
Fifth Printing — August, 1958
Sixth Printing — April, 1959

Basic Radio Course

PREFACE		5
CHAPTER 1...THE ELECTRON THEORY		7
	Positive electricity. Negative electricity. Electrons. Positive ion. Negative ion. Ionization. Conductors. Insulators. Electromotive force. Electron motion. Direct current. Alternating current. Frequency. The coulomb. The ampere. The milliampere. The ohm. The megohm. The volt.	
CHAPTER 2...OHM'S LAW AND THE RESISTOR		12
	Direction of current flow. Ohm's law. Using Ohm's law. Fixed and variable resistors. Why resistance is important. Heat and power.	
CHAPTER 3...WHAT IS INDUCTION?		18
	The magnetic field. Magnetic field polarity. The inductor. Magnetism creates current. Self induction. Inductance. The Henry. The millihenry. The microhenry. Filter, audio, and r.f. chokes.	
CHAPTER 4...CAPACITANCE		24
	Capacitors. How capacitors work. The farad. The microfarad. The micromicrofarad. The "why" of capacitance. How to increase or decrease capacitance. Dielectric constant. Dielectrics. Leakage. Voltage breakdown. Types of capacitors.	
CHAPTER 5...HOW CAPACITORS ARE MADE		30
	Air capacitors. Mica capacitors. Silver-mica capacitors. Paper capacitors. Oil-filled capacitors. Plastic-film capacitors. Bath-tub capacitors. Electrolytic capacitors. Electrolyte. Dry electrolytic capacitors. Capacitor polarity. Ceramic capacitors.	
CHAPTER 6...REACTANCE, IMPEDANCE, AND PHASE		35
	Phase. Leading and lagging phase. Phase shift. Voltage and current in coils and capacitors. Capacitive reactance. Inductive reactance. Impedance.	
CHAPTER 7...RESONANT CIRCUITS		42
	Series and parallel circuits. Resonance. Resonant frequency. Voltages at resonance. Phase at resonance. Q of coils. Impedance of series and parallel circuits. Loading of tuned circuits. Traps.	
CHAPTER 8...TRANSFORMERS—HOW THEY WORK		49
	The primary coil. The secondary coil. Air-core transformer. Transformer magnetic fields. Iron-core transformer. Transformation ratios. Counter e.m.f. Lenz's law. Magnetizing current. Power input versus power output. Transformer losses. Hysteresis. Eddy currents. Laminations. Step-up and step-down transformers. Tapped and multiple-secondary windings. Transformer troubles.	
CHAPTER 9...THE DIODE VACUUM TUBE		55
	Filament and plate. "A" battery. "B" battery. Electron emission. Indirectly-heated cathode. Plate current. Saturation current. Why the vacuum? Diode troubles. Gassy tubes. Microphonics.	
CHAPTER 10...TRIODE AND TETRODE TUBES		60
	Filament construction. Space charge. The triode. The control grid. Grid bias. Amplification factor. The tetrode. The screen grid. Grid-to-plate capacitance.	
CHAPTER 11...THE PENTODE VACUUM TUBE		66
	Secondary emission. Plate current versus screen current. The suppressor grid. The beam tube. Tube types. Multi-purpose tubes.	
CHAPTER 12...VACUUM-TUBE CHARACTERISTICS		71
	Plate characteristics. Transfer or mutual characteristics. Plate resistance. Transconductance or mutual conductance. The mho. The micromho. Dynamic characteristics. Load line.	

CHAPTER 13...	THE POWER SUPPLY	76
	Batteries. B-supply rectifiers. Half-wave rectifier. Full-wave rectifier. Smoothing filters. Choke-input filter. Capacitor-input filter. D.c. voltage output. Power supply troubles.	
CHAPTER 14...	POWER SUPPLY TYPES	82
	A-c.-d.c. supply. Eliminating the power transformer and filter choke. Filament network. Ballast resistor. Three-way supply. Selenium rectifier. Voltage-doubler supply. Auto-radio supplies. Synchronous vibrator.	
CHAPTER 15...	SOUND AND LOUDSPEAKERS.....	89
	Theory of sound. Sound waves. Frequency or pitch. Intensity or amplitude of sound. The dynamic speaker. The voice coil, cone, and spider. Speaker construction. Field-coil dynamic type of speaker. Permanent-magnet dynamic speakers. Hearing range. Low-note difficulties. The baffle. Speaker repair problems.	
CHAPTER 16...	THE POWER OUTPUT STAGE	95
	Voice-coil impedance. The output stage. Conditions for maximum transfer of powder. Output transformer. Turns ratio. Universal output transformer. Tapped output transformers.	
CHAPTER 17...	THE VOLTAGE AMPLIFIER	102
	Audio-frequency amplifier. Distortion. Phase inversion. Stage gain. Push-pull amplifier. Push-pull power output. Harmonic distortion. Harmonics.	
CHAPTER 18...	DEMODULATING THE R.F.....	110
	Modulation. Modulated carrier. Demodulating the signal. The crystal detector. The catwhisker. The diode detector. The grid-leak detector. The power detector. Germanium crystal.	
CHAPTER 19...	RECEIVER SELECTIVITY	118
	Tuned radio-frequency amplifier. Getting better selectivity. Cascaded r.f. stages. Selective amplification. Tracking of ganged capacitors. Faults in the t.r.f. amplifier. The superheterodyne. Converter tube. Intermediate frequency. Types of i.f. transformers. Transformer coupling. Critical coupling. Overcoupling. How much bandwidth? Defects in the i.f. stage.	
CHAPTER 20...	THE CONVERTER STAGE	125
	Mixing signals. Beat frequencies. How a mixer works. Why detection? Image rejection. Modern mixer circuits. The pentagrid converter.	
CHAPTER 21...	SOME OSCILLATOR CIRCUITS	132
	Damped oscillation. Driven oscillator. Vacuum-tube oscillators. How oscillators work. Oscillator bias. Types of oscillator circuits. Oscillator tracking. The padder capacitor. Oscillator troubles.	
CHAPTER 22...	HOW TO TRAP A SIGNAL.....	139
	Electrostatic field. Electromagnetic field. Vertical polarization. Horizontal polarization. Snaring the signal. Disadvantages of the outside antenna. High-impedance loop antenna. Directional properties of loops. Q of loop antennas. Improved loop antennas.	
CHAPTER 23...	SIGNALS IN SPACE	144
	Ground waves. Sky waves. Fading. Selective fading. Automatic volume control. Delayed a.v.c. A.v.c. troubles.	
CHAPTER 24...	RECEIVER REFINEMENTS	150
	Ground Tuning indicators. Electron-ray tube. Tuning indicator faults. Automatic tuning. Tone controls.	
CHAPTER 25...	INSTRUMENTS AND TOOLS	159
	Volt-ohm-milliammeter. Vacuum-tube voltmeter. Servicing tools.	
CHAPTER 26...	SERVICING TECHNIQUE	165
	Trouble-shooting methods. Voltage measurement. Resistance measurement. Circuit disturbance. Signal injection.	

Preface

WHEN radio servicing started there was a wide knowledge-gap between the men who designed and built radios and the men who serviced them. Those early technicians were well-named “radio mechanics,” for most of them were recruited directly from garages, battery shops, and electrical stores. The tools they carried with them were those that could be found on any auto repair bench, and the troubles they sought were mostly easily-detected mechanical failures, such as open filaments, broken connections, dead batteries, and short-circuits. The radio mechanic taught himself to locate and repair these defects without bothering to learn much about the *why* of radio reception, and what technical knowledge he did have was usually held in the form of hazy, ill-fitting mechanical analogies.

Then into this radio paradise entered trouble in the form of increasing receiver complexity. The new-fangled superheterodyne was prey to a whole host of maladies, none of which could be identified with the unaided sense of sight, hearing, touch, or smell. New “tools” in the form of electronic instruments as complicated as the receivers themselves began to appear on the market to aid in diagnosing and correcting these troubles; but before these instruments could tell the technician whether or not a particular portion of the circuit was operating normally, he had to know what was *supposed* to be going on in that circuit, and he had to be able to interpret and understand what the instruments were trying to tell him. In short, the would-be technician is forced—often quite against his will—to narrow the gap between what the radio engineer *must* know and what the radio technician *should* know: he had to become *less* of a mechanic and *more* of a technician.

Unfortunately, the need for technical knowledge today is a lot more evident than the means of satisfying it. Men who write books seem to consider radio theory strictly the province of the radio engineer, and most of their books are written in engineering jargon that may be crystal-clear to the man who has spent several college years

learning technical doubletalk, but is something less than transparent to the fellow who has ducked into radio through the side door of experience. When an occasional technical subject is "written down" for the radio technician, it is over-simplified to such an extent that both the theory discussed and the reader's patience suffer.

This book is intended to lie between these two extremes. It is written directly at the man whose primary interest in radio is of a practical nature, but it assumes that man wants to know *why* and *how* the apparatus with which he is dealing does its work.

While every effort is made to present basic radio theory in a clear, interesting, and graphic form, this theory is not reduced and distorted into electronic baby-talk. Instead, an attempt is made to raise the understanding of the reader through a step-by-step procedure and through the lavish use of analogies to the point where he can swallow the theory in its undiluted form. At the same time, through the casual introduction but careful explanation of technical terms, the technical vocabulary of the reader is gradually built up until, at the end of the book, he will be prepared to tackle and understand articles that would have been so much gibberish to him before.

Finally, the book has been deliberately written in an informal style that may seem startling to those who are accustomed to seeing technical writing always wearing formal dress. The writer not only believes that all learning should be fun, but he is firmly convinced that a little joking now and then is the best of bicarbonates to aid in the easy digestion of a complicated subject.

Chapter

1

The Electron Theory

THESE seems to be a growing idea in some quarters that radio servicing is being lifted out of the reach of the ordinary man. There are those who strongly hint that, unless you have a college degree in electrical engineering and have done post-graduate work on the atomic bomb, you have no business taking the back off an a.c.-d.c. receiver to replace a dial lamp.

"Modern receivers are so complicated," they tell us, "what with FM and television and everything, it is almost hopeless for the ordinary fellow to try to learn radio servicing."

To all of this the author says simply but emphatically, "Baloney!"

Anyone who can read and understand what he reads, who can reason from observed effect back to a logical cause, and who can handle a soldering iron, can learn to repair radio receivers *and do a good job of it*. Like everything else, radio servicing looks a lot more complicated and difficult to the uninitiated than it does to someone who works with it every day.

"I don't see how they can make head or tail of all that mess of wires," a customer will often exclaim when he sees his receiver chassis turned upside down on the service bench. What he does not grasp is that there is a great deal of repetition in both parts and circuits. The simplest and the most complicated receivers are each just an assembly of tubes, capacitors, resistors, coils, transformers, wire, and hardware. It is true that each of these basic components can have various forms, but the form has nothing to do with obedience to the law of electricity. A tuned circuit consisting of a coil and a capacitor looks the same to an electron whether it encounters the circuit in a home-made crystal set or the most modern and expensive television receiver. If you understand exactly what takes place in the single tuned circuit of the crystal receiver, you need not be concerned because the TV set has dozens of similar tuned circuits. Tuned circuits are not like girl friends; an increase in the number does not necessarily increase the complications.

The would-be serviceman must understand the nature and be-

havior of electrical currents. Then he must take up the various pieces of radio apparatus one at a time and consider them both from the point of view of their action in various electrical circuits and from the practical angle of physical construction, common defects, causes of failure, etc. Then he will be in a position to know exactly *why* a capacitor is used in any circuit and the effect its inclusion will have on the circuit action; he will be able to recognize the many different forms that capacitors take; he will be prepared to diagnose correctly the symptoms of a defective capacitor; and he will be able to do the same thing with any other piece of radio equipment.

Once thoroughly familiar with both the theory and practice of every item that is used in the design of a radio receiver or other electronic device, he will understand readily the functioning of any new circuit he encounters, for the "new" part of the circuit will be simply one of arrangement. To him it will represent just another grouping of his thoroughly understood circuit elements.

This book is a down-to-earth, "horse-sense" radio course, but do not get the idea that radio theory is to be neglected. You cannot become a good radio serviceman without a clear understanding of radio theory, but you can learn your theory in practical, usable form, stripped of all the double talk that makes it seem so much more complicated and difficult than it really is. Let us look at an example:

If we pass an alternating current through a capacitor and vary the frequency, we find that, as the frequency increases, more current passes through the capacitor. The engineers would have us remember: "The reactance of a capacitor is an inverse function of frequency."

If you want to remember it that way, go right ahead; but if you prefer simply to recall that, as the frequency of an alternating current goes up, the resistance of a capacitor to the passage of that current goes down, and *vice versa*, you will be just as correct. Really to know a thing and to be able to use it, you must know it in your own words.

But enough of telling what we are going to do! Let's start doing it!

The Electron Theory

Accepting the electron theory is a good bit like ordering hash in a restaurant: you must have faith. It is universally agreed that all matter is made up of atoms; yet no one, not even with the aid of the most powerful microscope, has ever seen an atom. But it is only by dissecting the atom—and it takes millions of them to make up a speck of dust—that we are able to find an electron.

The ordinary garden variety of atom is made up of assorted particles of electricity. In the center is a particle of *positive* electricity called the *nucleus*, and around this circulate one or more particles of *negative* electricity called *electrons*, in about the same manner as the planets in our solar system revolve about the sun.

The thing to keep in mind about these various particles is that

there are strong forces of attraction and repulsion connected with them. For example, a positive nucleus has more attraction for a negative electron than a throbbing crooner has for bobby-soxers, but two negative electrons or two positive nuclei simply can't stand the sight of each other any more than can two women wearing identical dresses.

Ordinarily, the positive nuclear charges and the negative electronic charge of an atom are in exact balance, but sometimes an atom loses one of its electrons and so becomes slightly positive, in which case it is called a *positive ion*. If, on the other hand, it becomes slightly negative by picking up an extra electron, it is called a *negative ion*. In either case, the atom is said to be *ionized*.

An atom that has lost one of its electrons and becomes positive has no morals at all, for it will steal any loose electron it can from a neighboring atom. This state of affairs makes it possible for an electron with an itching foot to swing along from one atom to another; and when we have enough of these electrons all traveling in the same direction for an appreciable length of time, we have an electric current.

Some materials give up electrons easily and allow them to move about when attracted electrically. Called *good conductors*, such materials include most metals. On the other hand, there are substances which stubbornly hang on to their electrons and refuse to give up any appreciable amount of them, even under strong electrical pressure. Materials of this kind, such as air, glass, and rubber, are called *insulators*.

The method by which electrons are persuaded to move through a conductor is the application of an *electromotive force* across the ends of the conductor. This electromotive force (e.m.f.) is produced in various ways, each of which produces a crowd of electrons at one end of a conductor and a scarcity of them at the other. One of the most common is by the chemical action in a battery. The chemical action is such that one terminal of the battery becomes positive and has a very strong attraction for negative electrons, and the other terminal becomes negative and is able to give up electrons very readily because it has a surplus of them.

When this battery is connected across a conductor, say a piece of wire, the electrons start slipping from the atoms near the positive terminal to that terminal. These atoms, in turn, grab some electrons from their neighbors on the other side. The neighbors do the same thing, and the process continues until the atoms at the negative end of the wire replenish their losses from the negative terminal of the battery. This whole bucket-brigade movement of electrical charge takes place at the terrific speed of nearly 186,000 miles a second.

Understand that a single electron does not zip from one end of the conductor to the other at this dizzy pace. The movement is similar to that which takes place when the last one of a whole row of dominoes, standing on end right next to each other, is pushed over—the toppling

movement flashes to the end of the row in a split second; yet each domino has moved but a short distance.

Each electron does drift slowly from one end of the conductor to the other, but its speed is much less and its path is much more erratic than that of the electrical charge itself. If we could paint an individual electron a bright red and were able to follow its progress through the conductor, we would find it following as erratic a path as a pin-ball-machine marble and moving along at an average speed of about 1 foot in 11 seconds.¹ This is its linear speed through the conductor. It whirls around the nucleus at 100 miles per second.

When the electrons move in a single direction through a conductor, we have *direct current* (d.c.). All batteries and some generators produce an e.m.f. resulting in d.c. Other devices, especially certain kinds of generators, produce an e.m.f. that periodically reverses its direction; the current that results from this type of voltage is called *alternating current* (a.c.). Each terminal of such a generator keeps

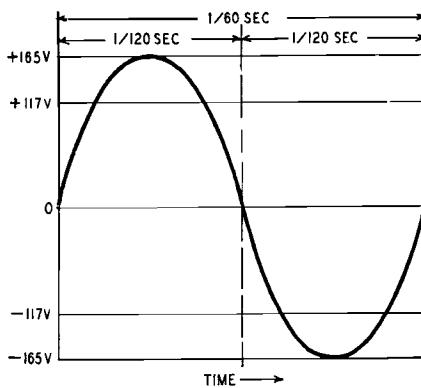

Fig. 101—Graph above shows a 60-cycle, 117-volt wave.

changing from positive to negative and back again, and the other terminal keeps changing its charge so as always to remain opposite to that of the first terminal.

The speed with which this voltage reverses may be from a few times a second to millions of times a second. The portion of its action during which an a.c. voltage starts at zero, builds up to a peak in one direction, falls to zero, builds up to a peak in the opposite direction, and again falls to zero is called a *cycle*. The number of cycles that occur in a second is the *frequency* of the alternating current. Most a.c. voltages furnished to residences are of the 60-cycle variety, and the diagram in Fig. 101 shows how a complete cycle takes place in $1/60$ of a second.

To use electricity, we must be able to control it; and to secure control, we must have methods of measuring it. The early physicists decided to establish a connection between the newly discovered electricity and the old established standards of weight; so they said that the amount of electricity required to deposit .001118 gram of silver from a standard solution of silver nitrate in water should be known as the *coulomb*. If a coulomb of electricity—about 6.28×10^{18} (6,280,000,000,000,000) electrons—flows past a given point in a second, a current of one *ampere* is said to be flowing. A thousandth of an ampere is termed a *milliampere*.

The unit used to measure the *resistance* of a conductor to the flow of current is the *ohm*. It was defined as the resistance offered to an unvarying electrical current by a column of mercury, 14.4521 grams in weight, at the temperature of melting ice, with a constant cross-sectional area, and 106.3 centimeters long. The *megohm*, often used in radio work, is 1,000,000 ohms.

Once the ampere and the ohm have been determined, the *volt*, the unit of e.m.f., is easily defined. It is simply the amount of e.m.f. that will cause a current of 1 ampere to flow through a resistance of 1 ohm.

And so we come to the end of the first chapter, and I still have not told you how to fix a radio; but do not be impatient. If you have understood all the foregoing, you have established for yourself a solid foundation upon which a complete mastery of the theory and practice of radio can be built.

¹Mueller, *Introduction to Electrical Engineering*, McGraw Hill.

Chapter

2

Ohm's Law and the Resistor

IN the first chapter we learned that an electric current is made up of a movement of minute negative particles called *electrons*; that these electrons are always attracted by a positive charge, so that an electric current always flows *from negative to positive*; and that we measure current in *amperes*, electromotive force in *volts*, and resistance to the passage of current in *ohms*. Now let's take it from there.

The man who gave his name to the unit of resistance had the bright idea of tying the units of current, voltage, and resistance together, in a simple formula so that, if you know any two of them, you could always find the third. This formula, which is known as Ohm's law, gets more of a workout than a drugstore telephone on a Saturday night, for you simply cannot do anything electrical without using it. You cannot even turn on your flashlight without Ohm's law getting into the act!

The importance of the formula is equaled only by its simplicity and ease of application. Ohm's law states that the current, measured in amperes, flowing in any portion of an electrical circuit is equal to the applied electromotive force in volts divided by the resistance in ohms. That is

$$\text{Amperes} = \frac{\text{Volts}}{\text{Ohms}}.$$

Since the current is referred to as the "intensity," the voltage as the "electromotive force," and the resistance to the passage of current simply as the "resistance," the formula is usually written with the first letters of these three terms

$$I = \frac{E}{R}. \quad (1)$$

If we multiply both sides of equation 1 by R, we have

$$RI = E \text{ or } E = IR. \quad (2)$$

Dividing both sides of equation 2 by 1 gives us

$$R = \frac{E}{I} \quad (3)$$

These various forms of Ohm's law enable us to determine quickly an unknown voltage, current, or resistance if we know the other two. Let us take the circuit of Fig. 201 as an example. Here we have three resistors, of 1, 2, and 3 ohms, respectively, hooked in series across a 12-volt battery. When resistors are connected in series, the total resistance is equal to the sum of their individual resistances; so we know that the resistance from A to D is equal to 6 ohms. We also know that the battery voltage that appears across these points is 12 volts; so we

Fig. 201—The circuit at the right shows how resistors in series can be used in a voltage-dividing network. The voltage drop across each resistor can be calculated by using Ohm's law. The sum of the voltage drops must be exactly equal to the battery voltage. A device requiring 2 volts for its proper operation could be placed across A and B. Similarly, a part needing 4 volts could be shunted across B and C.

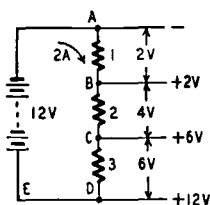

simply substitute these values in equation 1, and we find that 2 amperes of current will be flowing from point A to point D.

Using Ohm's Law

Ohm's law applies to any portion of a circuit. Let's consider just that portion between points A and B. We know that 2 amperes of current are flowing through this, as well as every other part of the circuit, and we know that the resistance between these two points is 1 ohm. Substituting these two values in equation 2, we find that the voltage drop from point A to point B is 2 volts. In the same way we learn that the voltage from B to C is 4 volts, and that from C to D is 6 volts. When these three voltages are added together, they total the same 12 volts with which we started; we have that pleasant and slightly surprised feeling we get when our check stubs and the bank's report on our balance come out exactly together.

This pleasant discovery is expressed by Kirchhoff's Law, another of the rules by which radio and electricity work. Kirchhoff's Law is a very simple one and it is valuable because it provides a way of checking the accuracy of calculations. The voltage drops in all parts of a circuit, it says, should, when added together, equal the voltage of the source. If, for instance, we had in addition to the 2-, 4-, and 6-volt drops of Fig. 201, an extra 2-volt drop, the total would be 14 volts. The battery (source) supplies only 12 volts so we would know something had gone wrong with our arithmetic and we should try it again.

Just to prove how well we can handle Mr. Ohm's handy little gadget, suppose we wanted to reduce the current flowing in our circuit from 2 amperes to 1 ampere. How would we go about it? Well, we have our battery voltage of 12, and we know that we want 1 ampere of current to flow; so suppose we substitute these two values in equation 3. We come up with 12 ohms as the required resistance. But there are already 6 ohms in the circuit; so we simply put another 6-ohm resistor in series with those we already have—say between points D and E—and our current is reduced to the required 1 ampere. For practice, why don't you figure out the difference that this will make in the voltages appearing at points B, C, and D?

In dealing with Ohm's law, there is one thing to keep clearly in mind: it works only when the quantities are expressed in volts, ohms, and amperes. Then milliamperes should be written: .010 ampere: Two megohms would be expressed as 2,000,000 ohms.

Fixed and Variable Resistors

Resistance is packaged in units called *resistors*. Some idea of their wide variety of sizes, shapes, and materials can be seen in Fig. 202. The most common type in radio work is the so-called carbon resistor, made by combining powdered carbon or graphite with a synthetic resin and an inert material such as talc, molding this into short sticks, and attaching flexible wire leads to the ends. By regulating the amount of carbon or graphite, the resistors can be made to have values from a fraction of an ohm to several million ohms. Cheap and small, they are not capable of handling much current without being damaged by the heating effect of that current; furthermore, they are quite likely to change value with age and temperature.

Wire-wound resistors are made by winding a wire made of a high-resistance metal such as Nichrome on an insulating form. Capable of handling much more current than composition resistors, they are also more stable. At the same time, they are more costly and bulky, and occasionally the wire fractures, resulting in their changing without warning from their normal value to an almost infinite resistance. Wire-wound resistors seldom exceed 100,000 ohms in value.

It is often desirable to be able to vary the value of a resistor. A slider can be arranged to move along the resistor and to make contact with the resistance element, varying the amount of resistance that appears between the slider and either end. If the resistor is made in the form of a circle, the slider can be attached to a shaft passing through the center of the circular resistance element, and then the variation in resistance can be accomplished by rotating this shaft with a knob. Such a knob-adjusting resistor is variously known as a rheostat, potentiometer, or volume control. The resistance element may be either wire-wound or composition. In volume controls, where the current

requirements are ordinarily very small, it is usually composition.

Why Resistance is Important

At first glance, you might think that resistance was a kind of villain of the piece. Here we have gone to a lot of trouble trying to cause an electric current to flow, either by building a battery or constructing a generator, and now Old Man Resistance is in there doing his level best to gum up the works by throttling the flow of current!

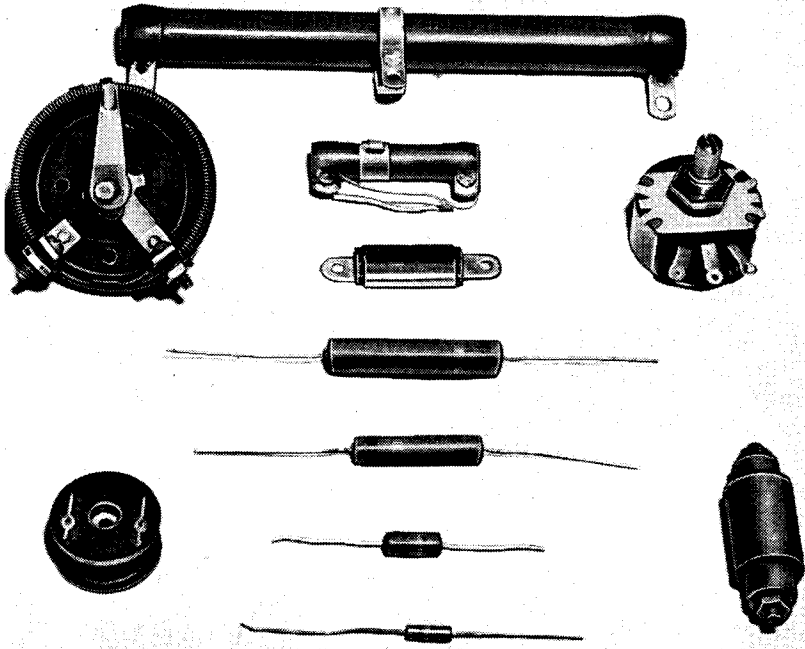

Fig. 202—Various types of fixed and variable resistors are shown here.

Actually, the ohm is as important as the volt, for, although the volt may be considered the generating force, the ohm is the controlling unit; and if we are to use an electric current, we must be able to control it. Being able to vary the amount of resistance in a circuit gives us a “valve-action” control of the current flowing through the circuit. At the same time, reference to Fig. 201 will reveal another use for resistance, that of “voltage dividing.” As can be seen, the 12 battery volts can be sliced up like a length of bologna into any number of smaller voltages by the use of resistors.

Still another use for resistance is to enable us to convert a change

in current into a change in voltage. Take a look at Fig. 203. Here we have a variable resistor R_1 and a fixed resistor R_2 hooked in series across a battery. The amount of current flowing through this circuit will depend upon the voltage of the battery and the resistance of R_2 plus that portion of R_1 through which the current passes. Any change in the amount of R_1 's resistance used in the circuit results in a change in the amount of current flowing. We know that the voltage appearing across R_2 depends upon the current flowing through it—for didn't Mr. Ohm decree that $E = IR$? So the change in current caused by

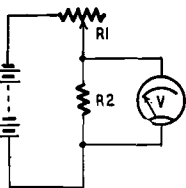

Fig. 203—The current flowing in the circuit shown at the left is determined by the setting of the variable arm of R_1 . The meter indicates the voltage across R_2 . The voltage across R_2 increases as R_1 decreases. Note that the meter does not read the battery voltage but simply the voltage across R_2 . The voltage drop across R_2 can never be greater than the battery voltage.

varying R_1 is faithfully reflected as a change in the voltage across R_2 . When we start studying vacuum-tube circuits, you will see how important this use of resistors is.

Heat and Power

In Chapter 1 we defined a good conductor as any material that gave up electrons easily and so permitted a current to flow through it readily. The materials of which resistors are made are no such pushover for an electromotive force, because they do not give up their electrons without a heated struggle. I use the word "heated" advisedly, for actual heat is generated by the passage of current through a conductor. This heat arises from the energy used in prying loose the electrons from the atoms of the resistance material. Since the electrical force that performs this prying is measured in volts, and since it takes more energy to move several electrons than it does only one, it is not surprising to find that the amount of heat produced is related both to the voltage and the current.

The amount of electrical energy or *power* expended—or dissipated as heat, in the case of a resistor—is measured in *watts*. The power in watts consumed in any circuit is equal to the product of the volts and the amperes; or, expressed in formula form

$$P = EI. \quad (4)$$

Equation 2 told us that $E = IR$; and when we substituted this value of E in equation 4, we have

$$P = I^2R. \quad (5)$$

Because electrical energy that is transformed into heat is considered lost, we often hear the heat losses of a resistor or conductor called the " I^2R losses." Resistors are rated in wattage as well as

resistance, and the wattage ratings vary all the way from $\frac{1}{4}$ -watt carbon resistors to wire-wound resistors of 100 or more watts.

Suppose we need a 1,000-ohm resistor that must pass 50 milliamperes of current. According to equation 5 the wattage requirements will be equal to $.050^2 \times 1,000$, or 2.5 watts. It is a good practice to allow for a 100% overload; so we select a 5-watt resistor.

You have heard about the boast of the packing houses that they use every part of the hog except his squeal. Well, the electrical engineers are just as good, for they even put these I^2R losses to work. In a vacuum tube, for example, it is necessary to raise the temperature of one of the elements (the filament or cathode) in order to persuade it to give up electrons more easily. This heating is accomplished by passing an electrical current through a resistance wire inside the tube. When you look at the incandescent filament of a dial lamp, you are staring some I^2R losses right in the face.

And so we arrive at the end of another chapter. By this time you should be on good terms with amperes, volts, and ohms. In fact, if anyone hands you any two of these measuring units, you should be able to rub them together and, with the aid of Ohm's law, produce the third right out of thin air. By the same token you should feel right at home with resistors. You should know what they are made of, what they are used for, why they get all hot and bothered when an electrical current is passed through them. And finally, you should know what's watt!

Chapter

3

What is Induction?

HAVE you sat in a hotel lobby where all was quiet until a cute blonde got up from where she had been sitting unnoticed behind a potted palm and glided across the floor? If you have, you may have noticed—if you were not too busy watching the blonde—that there was something about the girl *in motion* that seemed to exert a magnetic effect on every masculine head in the lobby.

Well, what this blonde has, our friend the little electron has, too; for as soon as an electron starts to move, it is surrounded by a magnetic field. Let me repeat this, for it is one of the most important facts in radio: *an electron in motion is surrounded by a magnetic field.*

The magnetic field surrounding a single hustling electron is too small to be easily measured with crude instruments, but when a few million of them cavort along through a wire, it is easy to observe the total magnetic field generated. Fig. 301 shows a vertical wire carrying the

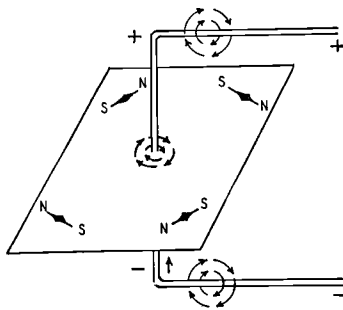

Fig. 301—The field around an electric current.

a current, with four compasses grouped around the wire. Since a magnetic field is the only force that affects a compass needle, and since lines of magnetic force enter the S pole of the compass needle and

are traveling in opposite directions.

leave by the N pole, we can see that the magnetic field about the wire consists of circulating concentric lines of force. Reversing the direction of the current causes the needles to reverse their positions, indicating the truth of the left-hand rule for wires:

Grasp the wire with the left hand so that the thumb points in the direction the current is flowing; then the fingers will be pointing in the direction in which the magnetic lines of force encircle the wire.

(Radiomen used to go along with Ben Franklin's original mistake and pretend the current flows from positive to negative—although we know that just the opposite is true. They, of course, had to use the right hand.)

Increasing and decreasing the current while moving the compass needles to different distances from the wire will show that the strength of the magnetic field is related to the amount of current flowing. It is easy to see why. More current means that more electrons are moving, and the total magnetic field about the wire is simply the sum of the magnetic fields of the individual electrons that are passing through the wire.

The Inductor

Suppose we wind our length of wire into a coil. What happens to the magnetic field about the wire? Fig. 302, showing two adjacent

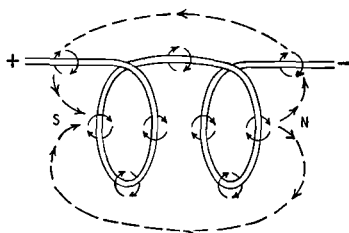

Fig. 302—The fields help or hinder each other.

turns of such a coil with an exaggerated separation between the turns, gives the answer. For one thing, we see that as the magnetic lines of force continue their dog-chasing-his-tail routine about the wire of each loop, all of these lines pass through the center of the loop, and as they do so, they are all traveling in the same direction. This is true for all the turns of the coil: when the lines of force are at the "most inside" point of the coil, they are all traveling in the same direction. A half-turn later, when each circling line of force is at its greatest distance from the center of the coil, it is traveling in exactly the opposite direction; and that means that *all* of the lines of force are doing so. Between turns, though, the lines of force of two side-by-side turns

When we reflect that these magnetic lines of force are true *forces* and can be added when they are working together, we come to the following conclusions about a coil of wire carrying a direct current:

1. The circulating lines of force about the wire add together inside and outside the coil to produce new and stronger lines of force that issue from one end of the coil, return outside to the opposite end, and then pass through the center of the coil.

2. Between the adjacent turns, the opposite-going lines of force buck each other and so cancel.

3. The new magnetic field is most intense inside the coil where all of the lines of force are crowded together.

4. The coil has a N and a S pole just as does a bar magnet, and reversing the direction of current through the coil causes these poles to exchange places.

5. Since the individual fields of all the turns of wire are added together to produce the field of the coil, it follows that the more turns of wire there are, the stronger will be the magnetic field of the coil. Also, since the strength of the field of each individual turn depends upon the amount of current flowing through it, so does the strength of the field of the coil as a whole depend on the current.

If a bar of iron is thrust through the center of our coil, the magnetic field is greatly increased. The reason is that a magnetic line of force feels about iron the way a cat feels about catnip. It just loves to wriggle through that soft iron, and it will endure a great deal of crowding to be permitted to do so. In fact, a coil with an iron core will accommodate several hundred times as many lines of force as will the same coil carrying the same current with only air in its center. The more lines of force there are, the stronger is the magnetic field.

Magnetism Creates Current

One of the nicest things about the study of electricity is that it is such a *vice versa* business: There are so many statements in this subject to which you can add, "And so is the opposite true." An example is our statement about the moving electron creating a magnetic field. *If a conductor is cut by the lines of force of a magnetic field, an e.m.f. is set up in the conductor which causes electrons to move, or current to flow.*

When we speak of the conductor being "cut by lines of force," we mean that either the conductor or the lines of force must be moving. A wire moved between the poles of a horseshoe magnet, a bar magnet thrust into a coil, or a wire placed so as to intercept the expanding and contracting lines of force that surround another wire through which a current of varying intensity is flowing all fulfill this requirement. Remember, though, that either the field or the conductor has to

hold still while the other moves through it—or else one has to be zigging when the other is zagging.

The intensity of the e.m.f. “induced” by this action depends upon how many lines of force are cut in how short a time. This means that a strong magnetic field with many lines of force and a very rapid movement of either those lines of force or the conductor will produce a high voltage.

Self-induction

And now we are ready to meet *self-induction*, which is just about as bull-headed and conservative a quality as you will find anywhere, inside electricity or out! It simply cannot bear a change. Take the case of Fig. 303. Here we have a battery connected across an iron-core

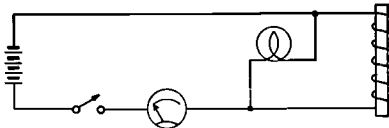

Fig. 303—Setup to demonstrate self-induction.

coil of many turns. A lamp that barely lights on the battery voltage is across the coil, and a switch and an ammeter are in series with it and the battery.

When we close the switch, the light glows dimly; but the hand of the current-indicating meter rises quite slowly to a maximum reading. Why so slowly? We know that electrons move with the speed of light. Why are the little cusses apparently dragging their feet just because there is a coil in the circuit? Well, when the current started to flow through the coil, a magnetic field started to build up around that coil. As the lines of force of this expanding field cut the turns of the coil, an e.m.f. was induced in those windings that had a polarity opposite to the voltage applied by the battery. This “bucking” voltage was very nearly equal to the battery voltage.

However, as the induced bucking voltage or back-e.m.f. approached the battery voltage, it slowed down the increasing current from the battery. This in turn slowed down the expansion of the magnetic field that was producing the bucking voltage.

As you can see, this gives the battery voltage the whip-hand: if the induced e.m.f. could rise to the value of the battery voltage, it would stop the current flow; and this would spell its own doom. The net result is that the battery steadily wins the tug of war, but it takes time. Eventually the current rises to the maximum amount the battery can push through the resistance of the coil wire, and then the magnetic field ceases to expand. It just hovers out there in the vicinity

of the coil without either increasing or decreasing. Since the lines of force are no longer moving and cutting the turns of the coil, there is no more back-e.m.f.

Now let us quickly open the switch. Instantly the ammeter falls to zero, and at the same instant the lamp flashes very brightly and then goes out. Where did this lamp-flashing voltage—obviously higher than our battery voltage—come from? How could current continue to flow through the lamp *after* the battery had been cut off? Gremlins?

No, the answer lies in what happened to that hovering magnetic



Fig. 304—This group of high-frequency (r.f.) inductors includes both transformers and chokes.

field when we opened the switch. Since this cut off the sustaining current, we simply knocked the props from under that field, and it did the only thing it could do: collapsed. As the field contracted, the lines of force whizzed through the coil turns faster than a small boy going through his yard gate at curfew time; and the speed with which these lines of force intercepted the wires accounts for the fact that a high e.m.f.—higher than the battery voltage—was set up in the coil.

You remember that the e.m.f. generated by the expanding magnetic field was of such polarity as to resist the voltage of the battery. As might be suspected, the voltage induced by the collapsing field is of opposite polarity and tries to keep the current flowing after the battery has been cut off. After doing all it could to prevent the current from starting to flow in the first place, now the self-inductance does all it can to prevent that current from stopping!

This property of a coil or wire that tends to *prevent any change* in the current passing through it—that always tries to preserve the *status quo*—is called *inductance*. The unit of measurement of how much of this property a circuit element has is the *henry*. When a current change of 1 ampere per second in a circuit produces an induced e.m.f. of 1 volt, the circuit is said to have an inductance of 1 henry. If 2 volts are produced, the inductance is 2 henrys, etc. Smaller units are the *millihenry* (one thousandth of a henry) and the *microhenry* (one millionth of a henry).

Inductors are often used in radio work, but they are usually called by some other name. For example, we have filter and audio chokes which consist of many turns of wire on iron cores and may have inductances from 1 to 100 henrys. R.f. chokes have fewer turns of wire with an air core, and they vary from a few microhenrys to 100 millihenrys. Fig. 304 shows a typical group of coils (inductors).

Inductance is chiefly concerned with coils, and anything having to do with coils is of major importance in radio. This business of magnetic induction is the key to understanding what goes on in many of the parts you find in any radio receiver. Do not, therefore, dismiss it as not being of practical value. A knowledge of magnetic induction is as practical in understanding radio as the knowledge of the alphabet is in learning to read.

Chapter

4

Capacitance

EVERY electrical circuit, whether it be a 1-inch length of wire or a cross-country telegraph line, has three “built-in” electrical properties: resistance, inductance, and capacitance. The first two of these we have already encountered in previous chapters; now we are ready to grapple with the third.

Capacitance is like discarded chewing gum; you may find it almost anywhere. *Any time you have two electrical conductors separated by a nonconducting medium, you have a capacitor; and a capacitor is to capacitance what a doghouse is to a dog; it is where you normally expect to find it.* By the light of this definition, you can see that your pocket watch and the furnace in the basement below form a capacitor; so does a wire and the antenna stretched above it; so does a moisture-bearing cloud and the earth beneath.

In this free or “stray” state, capacitance is of little or no value; in fact it is often a nuisance. But when it is controlled and “lumped” in definite units, it is every bit as important to electricity as are resistance and inductance.

In its “cultured” state, capacitance comes in the packaged form of *condensers*, the common name for *capacitors*. There is a wide variety in the form and material used in such capacitors; but before we start studying these practical units, let us see how a simple basic capacitor operates. Once we grasp how it works, we shall know how all capacitance units function.

Take a good look at Fig. 401. Here we have a capacitor C, consisting of two parallel flat metal plates with an air space between them. Switch S2 connects across these plates. The double-pole switch S1 permits us to connect the battery directly to the plates. An ammeter, an instrument for indicating both the intensity and direction of any electrical current passing through it, is inserted in the lead going to the top plate of the capacitor.

To begin, let us say that S1 is open and that we have momentarily closed S2 and then reopened it.

Now, suppose we close switch S1. As we do so, the ammeter pointer flips over and then drops back to zero, indicating that a momentary current passed through it. Next, let us open S1 so as to disconnect the battery. What happens? Nothing; the ammeter pointer does not budge. But, suppose we now close S2. As we do so, the ammeter needle flicks again, but in the opposite direction, indicating a reverse flow of current.

Paradox or Sense?

Several questions should be pulsing through your head at this point: Why did current flow in this circuit when we connected the battery? There was no complete circuit, for the plates of the capacitor were separated by insulating air. After the current started flowing,

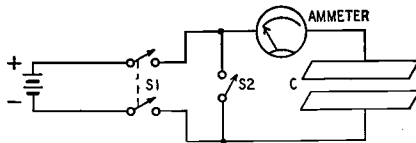

Fig. 401—Test setup shows capacitance effects.

why did it stop? Where did the current come from that caused the meter to flick when we closed S2? It could not come from the battery, for that had already been disconnected.

The explanations, as usual, go back to electron theory. The momentary closing of switch S2 before we connected the battery allowed any excess of electrons on either capacitor plate to flow through the switch and balance the electron distribution. At the instant the battery was connected, however, the positive terminal put a strong “come hither” on the negative electrons of the top plate, and they surged through the wire and the ammeter to that terminal, causing the ammeter to register their passage as they did so. At the same instant, the pent-up excess of electrons on the negative terminal of the battery rushed out on to the bottom plate of the capacitor like school kids spilling out on the playground at recess. The result of this simultaneous “push-pull” action was to leave the top plate with a deficiency of electrons, giving it a strong positive charge, while the lower plate was strictly “Standing Room Only” with electrons and so had a negative charge.

As more and more electrons left the top plate and crowded on the lower plate, the charges on the two plates increased *in opposite directions* until the difference between them was exactly equal to the difference in potential between the two terminals of the battery. At

this point, the electrons stopped flowing, because the pushing and pulling force of the charged plates exactly balanced the equal and opposing forces of the battery terminals.

Nothing happened when we opened S1, for there was no path by which the excess of electrons on the lower plate could reach the electron-hungry upper plate. Since this state of unbalance still existed, a voltage equal to that of the battery still was present between the plates, even though the battery itself had been disconnected.

The instant we closed S2 we provided the needed connecting path, and the displaced electrons rushed through it and through the ammeter to the upper plate. Since this time the electrons were flowing *to* the upper plate instead of *away* from it—as they were when the battery was first connected—the ammeter pointer moved in the opposite direction. As soon as the electrons were once more evenly divided between the two plates, they ceased to flow; and we were right back to the point we were before we started charging and discharging the capacitor.

We might have made one other experiment: When we had the battery connected to the capacitor (S1 closed), if we had slid a sheet of glass between the plates, we should have noticed that the ammeter pointer flicked again, indicating that more charge was moving into the capacitor. When we removed the glass, the pointer would have moved in the opposite direction, showing that this new additional charge had moved back out of the capacitor. An explanation of why the material used as the insulating medium of a capacitor (it is called the capacitor dielectric) affects the charge the capacitor will take will be given a little later.

It is apparent that a capacitor is a device for storing an electrical charge. The measure of its ability to do this storing is its *capacitance*. The amount of the charge stored depends upon how many electrons we can force to leave the top plate and congregate on the bottom plate. We know that the more voltage we have in our charging battery, the more power we have to do this forcing; so it should not come as a surprise that the unit used to measure the capacitance depends both on the number of electrons stored and the voltage necessary to do the storing. This unit is called the *farad*. One farad is the capacitance of a capacitor in which a coulomb (6.28×10^{18} electrons) of electricity is stored when an e.m.f. of 1 volt is applied. This unit is too large for practical use; so the *microfarad* (μf), a millionth part of a farad, and the *micromicrofarad* ($\mu\mu\text{f}$), a millionth part of a microfarad, are always used in radio.

The "why" of Capacitance

We have explained *what* happens when a capacitor is charged, but we have not explained *why*. Truth to tell, the pundits of electronics tend to take refuge in such phrases as "it is believed," "the theory is

held," and "we may assume" when they go to talking about this subject; but here is what is generally thought:

A charged capacitor looks like Fig. 402 in which the ellipses between the plates represent, in a greatly exaggerated form, the out-of-round orbits of the electrons of the dielectric atoms in their paths about their respective positive nuclei. The orbits are out-of-round because of the attraction of the positively charged upper plate and the repulsion of the negatively charged lower plate. Were the electrons of the dielectric free to move, they would go straight to the positive plate; but since they are tightly bound, the best they can do is deviate slightly from their normal circular path.

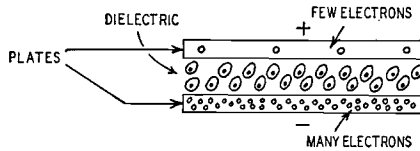

Fig. 402—Capacitor plates after being charged.

When these orbits are comparatively easy to push out-of-round, their counter-repelling action on the electrons trying to muscle their way on to the negative plate will be comparatively weak, just as a weak spring puts up a feeble resistance to being compressed; consequently a large number of electrons can force their way into the plate. The capacitance of the capacitor will be larger than it would be with a dielectric material in which the electron orbits were harder to distort. In the latter case, since the dielectric electrons would stubbornly refuse to budge from their orbits, the electrons trying to wedge their way on to the negative plate by distorting these orbits would be rebuffed, and the storage ability would be lessened.

We could increase the capacitance by using a thinner slice of dielectric material, allowing the plates to come closer together. This would reduce the total number of the repelling dielectric electrons and so permit more electrons to collect on the negative plate of the condenser.

It is evident, then, that we can increase capacitance in three different ways:

(1) We can increase the size of the active portion of the plates. The active portions of the plates are the portions that are directly opposite each other and with the dielectric material squarely between them. Increasing the size of these portions means that we have more electrons to draw from the positive plate and more room on the negative plate to store them. When you remember that the resistance of the electrons of the dielectric material is "softened up" by the *double* action of the lower and upper plates, working as a combined pushing

and pulling team, you can see why only the portions of the plates considered active have much effect on the capacitance.

(2) We can reduce the thickness of the dielectric material as discussed above.

(3) We can use a dielectric material whose electron orbits are more easily distorted.

The effect that the dielectric has on the capacitance is called the *dielectric constant* of the material and is expressed by the symbol K . Air is assigned a K of 1, and all other materials are compared with

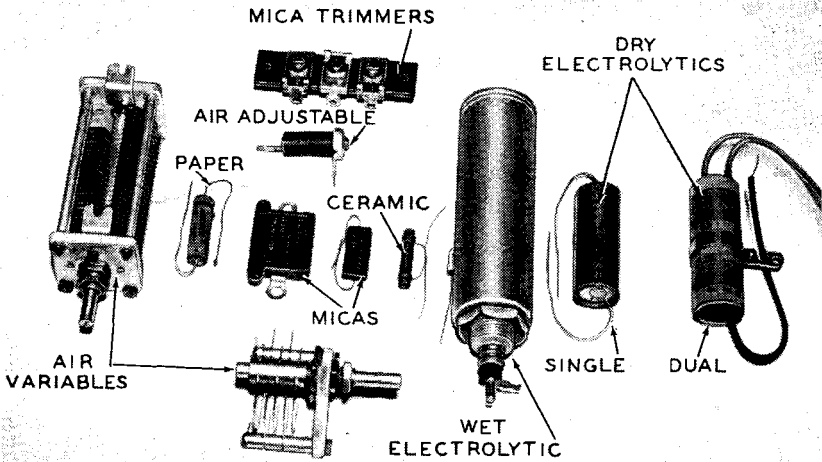

Fig. 403—These capacitors illustrate the many types the technician will encounter in his servicing.

this. For example, replacing the air dielectric of a given capacitor with mica will multiply its capacitance about 5 to 7 times; so we say that mica has a K or dielectric constant, of 5-7. In the same way glass has a K of 4.5-7, and some rutile ceramics have a K of several hundred. No wonder the little cusses can pack so much capacitance in so small a space!

An ideal capacitor would be one with insulation so perfect that absolutely no current could leak across from one plate to the other; but ideal capacitors are like ideal picnics—they are never quite realized. We have no perfect insulators, and there is always *some* leakage. A capacitor with high leakage current is said to have a *high power factor*; just remember that in capacitors power factors are like living costs—the lower, the better.

If we keep increasing the voltage across the plates of a capacitor, we eventually reach a point where the current will break through the dielectric and destroy it (unless, of course, it is air). Increasing the

thickness of the dielectric will make this breakdown voltage higher, but it will also reduce the capacitance. Most capacitors used in radio work carry, in addition to their capacitance value, a marking indicating the maximum voltage with which they are to be used. These voltage ratings may vary all the way from a half-dozen volts to several thousand for various applications.

The picture (Fig. 403) shows the wide variety of capacitors used in radio work. In the next chapter we will take up the actual construction of capacitors, the good and bad points of each type. We will also find out why it is necessary to have so many different forms of capacitors when they all operate on the same basic principle.

If you are impatient to get to this discussion of the practical aspects of capacitor construction, just remember that unless you have a good, firm grasp of the theory of operation, you will have a hard time understanding *any* type of construction, whether it be an internal combustion engine or a baby's three-cornered pants!

Chapter

5

How Capacitors are Made

A CAPACITOR, we learned in the last chapter, is a device for storing an electrical charge; and the amount of charge stored depends upon the voltage applied and the capacitance of the capacitor. We found that capacitance was related to the active area of the capacitor plates, the spacing between those plates, and the K of the dielectric employed. Two desirable features in a capacitor are low leakage current and high breakdown voltage. Now let us see how all these factors enter into the construction of actual capacitors used in radio work.

There are more ways of designating capacitors than there are of describing pretty girls, but one of the most common methods is to refer to the dielectric material; so let us begin with *air* capacitors—those with only air between their plates.

The simple capacitor discussed in the previous chapter used only two plates, but most air capacitors use several. The plates are divided into two sets, with all the plates of each set connected together, and with the plates of one set interleaved with the plates of the other, as shown in Fig. 501. This is to economize on space. You will recall that in a charged capacitor the electrons are crowded onto that portion of the negative plate facing the positive plate. That means that in a simple capacitor only one surface of the plate is used for electron storage.

However, as can be seen in Fig. 501, when the plates are interleaved, each surface of each negative plate is charged with electrons when it is between two positive plates, and the result is the same as doubling the size of the plates in a two-plate capacitor. It is just like buttering your bread on both sides!

By arranging our capacitor so that we can control the degree of interleaving of the plates, we can produce a variable capacitor similar to most air-spaced units used in radio work. Very stable as to capacitance, they have almost zero leakage current. They are bulky, though, and it is difficult to build very much capacitance into a reasonable

space. You seldom see air capacitors of more than 500 μf . The main trouble that develops in these capacitors is warping or bending of the plates so that they touch and short out. Occasionally sufficient dust gets between the plates to form a low-resistance path. In a variable capacitor, one set of plates (the rotor) must move, and a sliding wiper contact is used to make an electrical connection to this set. Sometimes dirt or corrosion causes this contact to become erratic.

A capacitor of considerably greater capacitance can be built in the same space by using thin sheets of mica as the dielectric and by employing much thinner metal plates. These *mica* capacitors as they are called, are enclosed in a case of bakelite or similar material for mechanical protection and to keep out moisture.

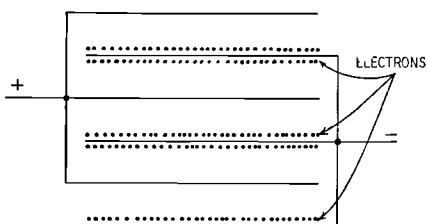

Fig. 501—Interleaved plates of a variable unit.

Since mica has a higher K than air, mica capacitors are more compact than air capacitors. Their leakage is nearly as low; and, by using thicker sheets of mica, the breakdown voltage can be made very high. You will find them in ranges from about 100 to several thousand volts, and from 100 μf to about 0.1 μf . However, they are comparatively expensive and as breakdown voltage and capacitance increase, they become quite bulky. A very stable type of mica capacitor, the *silver mica*, is made by using silver plating directly on the mica sheets instead of metal plates.

Mica capacitors do not give much trouble, but they do give some. In fact, like an "angel child," micas develop faults just often enough to waste a lot of your time checking everything else before your suspicion finally falls on them. Occasionally they break down and short out, or the wire lead connecting to a set of plates makes a poor contact and causes an "open" capacitor. More rarely, moisture may get in and cause a high leakage current.

Paper capacitors are the workhorses of radio; they really carry the load. Even an a.c.-d.c. midget has a dozen or so of them. They usually consist of two long, thin strips of aluminum foil, insulated by paper and rolled up in a tight little cylinder, with wire leads from each strip of foil being brought out of opposite ends. They are covered, treated with oil, and sealed with wax against moisture.

Paper capacitors are ordinarily found in values from about .001 to several microfarads, and from 100 to 1,600 volts. They are more compact than micas and cheaper, but they have somewhat higher leakage currents and deteriorate with age because of the gradual penetration of moisture into the paper.

Immersing a paper capacitor in certain types of oil increases its breakdown voltage and also increases its life because the oil prevents the entrance of moisture. That is why much military equipment, equipment that *must* be dependable, uses *oil-filled* capacitors instead of the ordinary paper kind. The smaller ones are sometimes called "bathtubs."

Thin plastic films have been used in place of the paper as a dielectric, and some of these plastic-film capacitors have electrical qualities superior even to mica units.

Paper capacitors have the same shorting and open troubles to which micas are occasionally prey, but they have them much more often. They are more likely to become leaky, too; and if they become too hot, the wax runs out of them and allows moisture to enter easily. Still they are by far the most often-used capacitors in radio because of low cost.

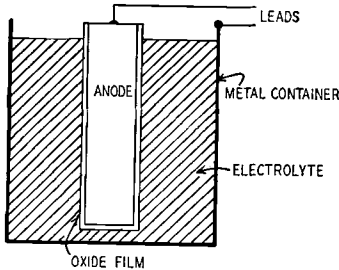

Fig. 502—Structure of a wet electrolytic capacitor.

For securing the most capacitance in the least space for the smallest amount of money, *electrolytic* capacitors are the answer. These come in two kinds, wet and dry. Fig. 502 is a sketch of a wet electrolytic. It consists of an aluminum plate, called the anode, immersed in an electrolyte, such as a boric acid solution. The anode has on its surface a very thin oxide film that has been formed electrochemically prior to assembling the capacitor and putting it into its case.

Following the previous explanations, you might jump to the conclusion that the electrolyte is the dielectric, but that is not true. The dielectric is the thin oxide film—which incidentally has a K of about 10. The aluminum anode forms one plate of the capacitor, and the electrolyte forms the other; the metal container simply serves as a means of making contact with the electrolyte.

Dry electrolytic, like *dry cell*, is somewhat of a misnomer. *Damp* electrolytic would be better, for in such a capacitor the liquid electro-

lyte is replaced with a paste. What is more, the anode is replaced with an oxide-coated strip of aluminum foil, and the container is replaced with an uncoated strip of foil called the cathode foil. These two strips of foil, with the electrolytic paste and a suitable mechanical separator between them, are rolled into a bundle in exactly the same way as are paper capacitors. The result is a convenient cylinder.

The capacitance depends on the surface area of the anode and on the nature and thickness of the film. To increase the surface area, the anode foil is frequently etched with acid, and the increased area of the "hills and valleys" thus produced on the foil surface increases the capacitance of an *etched-foil* capacitor over that of a plain-foil unit by two to seven times. Another way of doing the same thing is to spray molten aluminum on a strip of cotton gauze to produce a gridlike anode that will give a capacitance 10 times that of a plain anode strip. These are called *fabricated-plate* electrolytic capacitors.

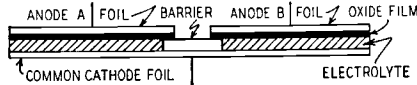

Fig. 503—Single container holds two capacitors

The thickness and nature of the oxide film are determined by the forming process. While a thinner film increases the capacitance, it also lowers the breakdown voltage. Electrolytics used in radio are found in capacitances of a couple to several hundred microfarads and in a voltage range of 6 to 600. By using more than one anode strip or more than one cathode strip, and by having barrier strips separating these units, it is possible to have more than one capacitor in a single container. Fig. 503 shows one such dual-unit arrangement.

Electrolytics are unlike other capacitors in that they ordinarily are *polarized*. This means that they must be used only with d.c. voltages and that the anode must always be connected to the positive point. If these rules are not followed, the oxide film will disintegrate and the capacitor will be destroyed.

An electrolytic capacitor is only as good as its oxide film, and various factors can injure this coating. A temporary surge of high voltage may puncture it; but if the voltage is quickly reduced, the film will usually heal itself. A reverse current through the capacitor, impurities in the materials used, long subjection to too high a voltage, and too many months spent lying unused on the shelf will usually result in permanent damage. Electrolytics are usually designed to operate between 32 and 140 degrees F, and they should not be subjected to temperatures far beyond these extremes for any great length of time.

If the film is broken down, the capacitor usually appears as a partial or complete short, and the leakage current is excessive. If the electrolyte dries out or if one of the connecting leads becomes separated from its foil, the capacitor shows an open circuit. Sometimes, before complete evaporation of the electrolyte, the capacitor shows a marked loss of capacitance.

A comparatively new type of capacitor that is rapidly gaining in popularity is the *ceramic*. It consists of a tube of rutile ceramic with the inside and outside plated with silver. The two silver coatings are the capacitor plates, and the ceramic material is the dielectric—with a K of up to 170!

Ceramics, like some women, seem to have everything—small size, high capacitance, high voltage rating, and low power factor. What is more, by regulating the mixture of the ceramic material, the capacitor can be made to have a positive, zero, or negative temperature coefficient, which is another way of saying that the capacitance can be made to increase, stay the same, or decrease with a rise in temperature. This feature compensates for heat changes in other components of an electrical circuit. When the capacitance of these components “zigs” with an increase in temperature, you can employ a ceramic condenser that “zags” an equal amount, and *vice-versa*, and thus maintain the over-all capacitance constant.

The manufacturers did not develop all these different types just to show what they could do. Each type fills a particular need. The choice for a particular job depends upon which will do the work best for the least cost. In some spots the most important thing is lots of capacitance; so an electrolytic is used. At another point the capacitor must not change its value; so a silver-mica unit is employed. If the leakage must be extremely low, an ordinary mica serves nicely; and for run-of-the-mill applications, paper capacitors do the job. Air-spaced units are used for variable and semivariable duty because of obvious mechanical advantages.

Now that we have become thoroughly familiar with the strengths and weaknesses of the coil and the capacitor, it is high time that our hero and heroine meet; and that they will do in the next chapter. Don't miss this thrilling event, folks, “When Coil Meets Capacitor,” for that is how radio began!

Chapter

6

Reactance, Impedance, and Phase

WE are now nearly ready to splice inductance and capacitance together into that blissful state known as “the tuned circuit.” But before the actual wedding takes place, we ought to make sure that the union can withstand any and all strains that may be placed upon it. It is true that we have observed how both an inductance and a capacitance behave under the influence of a direct current, but do we know what they will do when an a.c. voltage starts pushing and tugging at them? Perhaps it would be well to investigate this angle before we bestow our blessing on the marriage.

You cannot penetrate very far into the a.c. woods without having a clear understanding of *phase*; so we may as well get that straight right now. Phase simply means *comparative time of occurrence* as applied to actions, changes, or events. If two things happen together, we say they are *in phase*. If one happens first, we say that it has a *leading phase*. The thing that happens second is said to have a *lagging phase* with respect to the first.

Consider the case of you and your one-and-only doing a dance step. If the feet of both are in phase, her foot moves back at the same instant your foot moves forward. If your foot has a leading phase, it will move forward before hers is out of the way, and you will probably step on her toes and be told you are a poor dancer. If your foot has a lagging phase, she is doing the leading, and you are going to be a hen-pecked man!

As applied to electricity, phase usually means a comparison between similar changes in two or more different voltages or between a single voltage and its accompanying current. For example, Fig. 601 shows what happens when an a.c. voltage is applied across a pure resistance. Don't be surprised if you don't see it; Fig. 601 has probably balled up more students than any other diagram in the science of radio! It's supposed to show the life history of a cycle of alternating current. In our figure, having chosen the standard 60-cycle current, our base line is laid off in fractions of a 1/60 second. This makes it a

time chart, just like the rolls that record the temperature for a day, with a thermometer-controlled pen making a continuous track. Any point on the voltage curve on the chart will tell you just what the voltage is at that instant—the curve is simply a combination of all those instantaneous voltages.

No, alternating current really does not wiggle as the chart might lead you to believe. What happens is that current from the alternator starts to flow through the resistor, starting with very low (zero, to be exact) voltage and current. Both current and voltage rise until, at the end of $1/240$ second, we have maximums of 170 volts (dashed line) and $2\frac{1}{2}$ amperes (solid line).

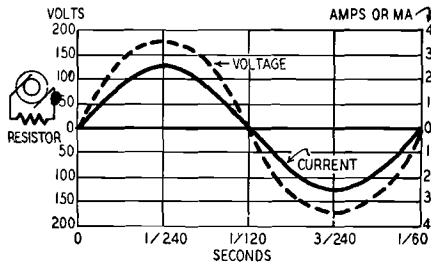

Fig. 601— E and I in a resistance are in phase.

The exact quantities are unimportant; in many radio circuits we have alternating currents of some hundreds of volts at only a few milliamperes, and in some welding circuits there may be hundreds of amperes with only a few volts. In most a.c. diagrams, voltage and current curves are arbitrarily drawn the same height—see Figs. 602 and 603. The only reason we didn't do it here is that here is that the two curves would then be on top of each other, and you couldn't tell them apart. Neither is the frequency important; we have used 60 cycles because it's common, but the story would be equally true at radio frequencies.

But now—because of the way an alternator is built—our voltage and current start to drop, and at the end of $1/120$ second there is no voltage across the resistor and no current flowing through it. Then the current starts to flow through the resistor *in the opposite direction*. Our clever mathematicians represent these volts and amps in the reverse direction by just drawing the voltage and amperage curves in the opposite direction to the first ones. Neat, eh?

Following the chart, we find that voltage and current in this direction again rise to a maximum in $1/240$ second from the time they started, and in another $1/240$ second are also back to zero. Total time $1/60$ second, and we are back at the end of the circle (or cycle—it's the Greek word for circle) and ready to start all over again.

This is all to tell you what you probably don't need to be convinced of—that the voltage across the resistor and the current through

it are exactly in phase, and that when the voltage is maximum or minimum, so is the current; and both reverse precisely in step. But when the resistor is replaced by either an inductor or capacitor, this harmonious state of affairs no longer prevails. A *phase shift* takes place, and the current reaches a maximum value at a different time from that at which the voltage is highest. Let us see why.

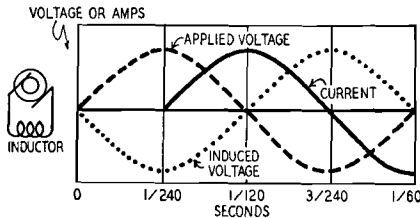

Fig. 602—Phase relations in inductive circuit.

Fig. 602 shows what happens when an inductance is placed across the output of an a.c. generator. The dashed line shows the voltage applied to the coil. You will recall from our discussion of self-induction (read it again if you don't) that the changing current through the coil produces a counter-e.m.f. (voltage) very nearly equal to the applied voltage but directly opposed to it. This induced voltage is shown by the dotted line. Notice that when the applied voltage is positive (or for a.c. it might be better to say "in one direction") this induced voltage is negative ("in the other direction") and *vice versa*.

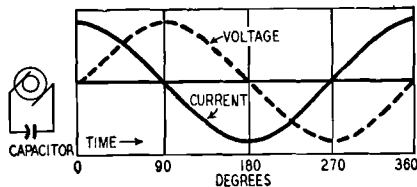

Fig. 603—Current leads in capacitive circuit.

Remember that this induced e.m.f. is produced by the expanding or contracting lines of force cutting the turns of the inductor. Further recall (or re-read) that these lines of force are in motion *only when the current is changing value*. Still further, the induced voltage is highest when the movement of the lines of force—and consequently the *rate of change* of current—is fastest. Keeping all of this in mind (yes, I know it's a neat trick), where would you say the rate of change of current on Fig. 602 is the greatest? the least?

The solid line represents the current flow. The rate of change is highest when this line is most nearest vertical; least, when it is horizon-

tal. As you suspected all along—but can now see on the diagram—the rate of current change is least when the current itself is maximum. It is at these maximum-current points that the induced voltage—sustained *only* by a *changing* current—is zero. On the other hand, the *rate of change* is greatest at the point where the current is just starting to reverse its direction or cross the zero line; and this is the point of maximum induced voltage.

In experimenting with an induction coil, we found that the current reached a steady value a split second *after* the voltage was applied. We can see from our diagram that the current peaks are separated from both the induced and the applied voltage peaks by a quarter of a cycle. Since we know that we must apply the voltage first, we can see that in a pure inductance the current lags the applied voltage by a quarter of a cycle.

The armature of an a.c. generator has to make one complete revolution or turn through 360 degrees to produce one complete cycle of voltage. The angle through which this armature has turned from the starting point is indicated in degrees along the time axis. This is all there is to “degrees,” as applied to phase lead or lag or other a.c. terms. It is convenient to divide the cycle (remember, it’s a circle) into 360 degrees and refer to fractions of a cycle in degrees instead of saying—as we did, clumsily— $1/240$ second, etc. Every quarter of a cycle is seen to occupy 90 degrees. Do you see why we say that, *in a pure inductance, changes in current lag changes in applied voltage by 90 electrical degrees?*

Fig. 603 shows what happens when an a.c. generator is connected across a capacitor. The dashed line again represents the value and polarity of the applied e.m.f. with respect to time. As the voltage first starts to rise in the “positive” direction, and electrons are easily pushed onto one of the plates of the capacitor and rush on at their maximum rate, for they encounter little resistance. But as this plate acquires more charge, its voltage rises (note dashed line) and begins to repel the electrons the generator is trying to force upon it. The movement of electrons, which makes up the current in wire circuits, slows down and finally stops when the applied e.m.f. and the electron charge have reached their maximum values (at 90° , or one-quarter of a cycle). Then, as the applied voltage starts to decrease, *the packed electrons begin to flow back into the wire*, against the applied voltage, through the generator, and on to the other plate. They keep right on flowing in increasing number while the applied voltage falls to zero and starts to build up in the opposite direction; but the current again begins to droop as the other plate nears its maximum charge. Thus we see that the current through the circuit is maximum when the applied voltage is minimum and is at its minimum when applied voltage is highest. Since the electrons have to flow onto the plate of the condenser *before* its voltage can rise, it is easy to see why *the current through a pure ca-*

capacitance leads the applied e.m.f. by 90 electrical degrees.

You have noticed that a capacitor, which says a firm "No!" to the passage of d.c. after it has once become charged, seems to murmur a coy "Maybe" or even "Yes" to the knocking of a.c.? While the electrons do not actually pass through the dielectric material, their rushing back and forth through the connecting circuit from one plate to another creates an alternating current in that circuit just as if the capacitor were replaced by a resistor.

We say "resistor" instead of "short circuit," for the capacitor does offer some opposition, depending on its capacitance and the frequency of the applied a.c., to the passage of current. As the capacitance is increased, more electrons must be moved to charge it each time; therefore, the current that is composed of the movement of these electrons is increased just as if the equivalent resistance represented by the capacitor were lowered. If the frequency of the applied voltage is increased, the electrons have to make more trips back and forth between the plates in a given length of time, and more electron trips mean more total current just as if the equivalent resistance were lowered again.

This "equivalent resistance" offered by a capacitor to the passage of a.c. is called *capacitive reactance*, has the symbol X_c , is measured in ohms just like resistance, and for any given capacitor can be found by the formula:

$$X_c = \frac{1}{6.28 f C},$$

in which f is the frequency in cycles, C is the capacitance in *farads*, and 6.28 is 2π (π is your old friend of grammar-school days, 3.1416). If you want to know the reactance of a 1-uf capacitor at 60 cycles, you simply substitute in the formula, not forgetting to change microfarads to farads. Of if you want to work with microfarads, simply multiply the numerator by a million, thus:

$$X_c = \frac{1,000,000}{(6.28) (60) (1)},$$

and you find that the answer is approximately 2,654 ohms.

When you recall that an inductance is stubbornly opposed to any change in the amount of current flowing through it, and also remember that the current in an a.c. circuit is changing almost continuously, it should be easy to see that an inductance, too, is going to offer more than a little opposition to the flow of a.c.

The amount of this opposition increases when either the inductance or the frequency of the applied voltage is increased. Since the induced or opposing voltage increases with the amount of inductance encountered, it is not hard to understand why a greater inductance will offer more opposition to the flow of current. The induced voltage also depends on the speed with which the expanding and contracting lines of force cut the wire; and since an increase in frequency means that the

lines have to speed up in order to go through their expanding-contracting routine more often in the same space of time, no great brain is required to grasp why an increase in frequency stirs up more opposition to current flow.

This resistance which an inductance presents to the flow of a.c. is called *inductive reactance*. It has the symbol X_L , is measured in ohms, and is found by the formula:

$$X_L = 6.28 f L,$$

in which f is again the frequency in cycles per second, L is the inductance in henrys, and the 6.28 is 2π , the same ancient mathematical pastry we had served up in capacitive reactance. If we want to know the reactance of a 10-henry choke to a 60-cycle voltage, simply substitute in the formula:

$$X_L = (2) \times (3.1416) \times (60) \times (10).$$

and we find the answer: just under 3,770 ohms.

To review a little while we catch our breath: *Resistance* is the opposition offered to the flow of a steady direct current; *Reactance* is a specialized form of opposition that a.c. runs into. Reactance comes in two flavors: *capacitive or inductive*, according to whether the current leads or lags the voltage. While all three impede the flow of current, they are not at all alike. Resistance uses up power and dissipates it in the form of heat. Reactance transforms electric current into a magnetic field in an inductance or an electrostatic field in a capacitor for a portion of a cycle and then returns this stored energy as an electric current during the remainder of the cycle. With pure reactance in the circuit—never actually found in practice—the energy is just swapped back and forth from one form to another without any loss of power. In a purely reactive circuit, there is a 90-degree phase shift in one direction or the other from the in-phase condition of a purely resistive circuit. The more resistance we have in comparison to the reactance, the fewer are the degrees of phase shift (the closer together are current and voltage maximums or minimums).

Capacitive and inductive reactances have exactly the opposite effect on phase, and can be combined just like positive and negative numbers. In a circuit containing both, the effective reactance is found simply by subtracting the smaller reactance from the larger and giving it the name of the larger. For example, in a circuit containing 15 ohms of capacitive reactance and 10 ohms of inductive reactance, we just take 10 from 15 and say that the circuit has 5 ohms of capacitive reactance.

In addition to reactance, all actual circuits have some resistance; and we have a special word to describe this total opposition to a.c. That word is *impedance*, represented by the symbol Z , and it means "reactance and resistance." The two are somewhat like fractions and decimals in that you cannot add them directly. You have to extract the square root of the sum of their squares, which gives us the formula for finding impedance:

$$Z = \sqrt{R^2 + (X_c - X_L)^2}$$

Suppose, for example, we have a circuit containing 4 ohms of resistance, 10 ohms of capacitive reactance, and 7 ohms of inductive reactance (total reactance $10 - 7$, or 3 ohms capacitive). Substituting these values in the formula:

$$Z = \sqrt{4^2 + (10 - 7)^2} = \sqrt{16 + 9} = \sqrt{25} = 5 \text{ ohms.}$$

A typical inductor, capacitor, and resistor are shown in Fig. 604.

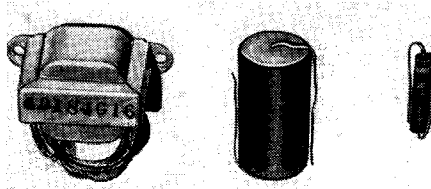

Fig. 604—Chief actors—inductor, capacitor, resistor.

But here it is the end of the chapter, and the union of capacitance and inductance into a tuned circuit—like the marriage of a woman and a reluctant man—has been repeatedly postponed. These nuptials will take place in the very next chapter!

Chapter

7

Resonant Circuits

TUNED circuits do for the radio engineer what good looks do for a girl: they allow him to select what he wants and reject what he does not want—from the available alternating current spectrum. This ability to put out the welcome mat for a particular frequency and to cold-shoulder others is of utmost importance. It permits the engineer to “tune” his radio circuits, and without tuning there would be no radio as we know it.

Since all tuned circuits consist, essentially, of combinations of a capacitor and an inductance, their variety is not infinite. In fact, they come in just two models: the *series* and the *parallel*, of which Fig. 701 and 702 are illustrations. Note carefully that the two types are deter-

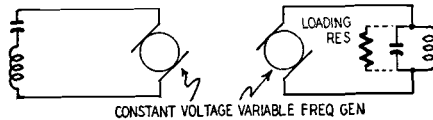

figs. 701 and 702—The series and parallel tanks.

mined by whether or not the *applied voltage* is inserted in series with the capacitor and inductance or whether both of these circuit elements are arranged in parallel with this applied e.m.f. A parallel tuned circuit is *not* so named because the capacitor and coil are in parallel with each other, but because both of these are connected in parallel with—or directly across—the *applied voltage*. In a series circuit, the applied current must go through *both* coil and capacitor; in a parallel circuit it has its choice.

Suppose the series circuit of Fig. 701 is connected across a generator of constant voltage but variable frequency. Then suppose we change from a very low to a very high frequency. Recalling that the reactance (resistance to the passage of a.c.) of a capacitor goes down with an increase in frequency whereas the reactance of a coil goes up,

we can see that at a low frequency the excessive capacitive reactance prevents much current from flowing through our series circuit. At the high frequency, on the other hand, our capacitive reactance decreases, but the inductive reactance rises sharply and still prevents a great deal of current from passing. However, at some one frequency, called the *resonant frequency*, the reactance of the coil and that of the capacitor will be exactly equal, and the current will rise to a maximum value.

The reason for this rise in current is clear when we remember that capacitive reactance and inductive reactance are *opposite* in sign and must be combined like positive and negative numbers in algebra. Remember that a capacitor causes the current to rush *ahead* of the voltage, but an inductor holds it lagging *back* after the voltage; therefore when the two are in series, the one undoes what the other does. This means that at resonance our total reactance is equal to the sum of two numbers equal in value but opposite in sign—or zero. Since the reactances cancel, the only thing impeding the flow of current through the series circuit is the ohmic resistance.

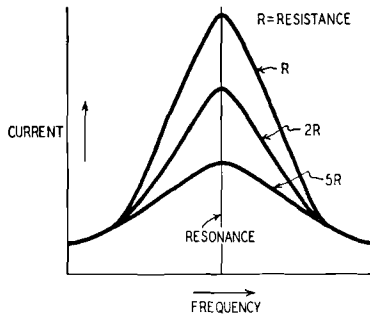

Fig. 703—Resistance effect on series circuit.

The lower this resistance is, the higher the current at resonance, as is shown in Fig. 703. When resistance is increased, it flattens out the current peak; but since the resistance enters the picture seriously only in the immediate vicinity of resonance, the curves tend to coincide at points removed from resonance and at which the capacitive or inductive reactance is much greater than the resistance.

At the resonant frequency, the sizes of the coil and the capacitor are such that the time necessary for charging and discharging the capacitor is equal to the time needed for building up the current through the inductor and letting it die down. The discharging capacitor sends a heavy pulse of current through the coil; and when this current dies down, the collapsing magnetic field returns this charge to the capacitor. Look at Fig. 704. Suppose we had a coil and capacitor hooked up as in Fig. 702 and were able suddenly to put a big negative charge on one

of the capacitor plates, as in 704-a. Electrons would immediately attempt to flow around to the other plate to neutralize the charge and get everything back to normal again. But in doing so, they have to flow through the inductor. This sets up a magnetic field which tries to oppose their passage. At 704-b we see a big magnetic field and no excess of electrons on either plate. The current is ready to stop flowing. But now the magnetic field starts to collapse, forcing electrons around (still in the same direction) onto the bottom plate of the capacitor. By the time the field has collapsed entirely, the situation is as in 704-c, and the electrons, now crowded onto the bottom plate, start to flow around to the top again, producing the condition of 704-d, which is identical with 704-b, except that current is flowing in the opposite direction.

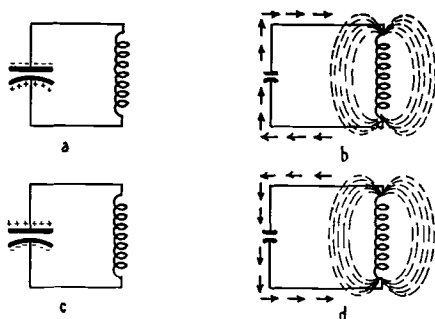

Fig. 704—The electron flow in a tuned circuit.

At resonance, this swapping of energy is precisely timed, and heavy current is moved through the circuit. At frequencies other than resonance, things are more or less out of step, and the consequent confusion reduces the amount of current that can be handled.

A check with a voltmeter across the capacitor and the inductance of a *series-tuned circuit* reveals that a *considerably higher a.c. voltage is found across each than across the combination of the two.* To understand how one plus one can equal considerably less than two, remember that, although the current through a purely resistive resonant circuit is in phase with the applied voltage, this same current is leading the voltage across the capacitor by nearly 90 degrees and lagging the voltage across the inductance by approximately the same angle—just another way of saying that the voltages across the capacitor and the inductance are nearly 180 degrees out of phase with each other. Voltages 180 degrees out of phase are “bucking” voltages, working directly opposite to and cancelling the effects of each other. That is why the total voltage across the combination of capacitor and inductor can be less than the voltage measured across either one of them.

Let us consider an example: Suppose, as is shown in Fig. 705 a 1-henry coil and a 7.03- μ f capacitor are connected in series across a generator that put out 100 volts at 60 cycles. Suppose, too, that the total ohmic resistance of choke and capacitor is 100 ohms. Using the form-

ulas $X_L = 2\pi fL$ and $X_C = \frac{1}{2\pi fC}$ to find the reactances of the coil and

capacitor, respectively, we discover (by no coincidence!) that each has, at 60 cycles, a reactance of about 377 ohms. Since these two reactances cancel each other, only the 100 ohms of resistance impedes the flow of current through the circuit.

Fig. 705—The values chosen for the coil and capacitor in the circuit shown at the right are for resonance at 60 cycles.



Whipping out and applying our trusty Ohm's Law ($I=E/R=100/100$) we learn that our 100-volt generator will send 1 ampere of current surging back and forth through the circuit. But the voltage drop across a capacitor or coil is equal to its reactance in ohms multiplied by the amperes of current flowing through it: thus we discover that we would have about 377 volts across our capacitor and another 377 volts across our inductance. Believe it or not, but you can try it with any 100-volt a.c. source and a 1,000-ohm-per-volt meter!

Assuming that what we want to do with our series tuned circuit is to obtain a maximum flow of current through it, our best circuit is the one with the least resistance. Since the major portion of this resistance below 30 megacycles is contained in the coil, it follows that a high-inductance, low-resistance coil is ideal. The symbol Q , used to indicate this measure of merit of a coil is defined as the ratio between the coil's reactance and its resistance. If we were to assume that our coil had a resistance of 100 ohms then the Q of the coil used in our illustration would be equal to 377/100 or about 3.75. Coils used in radio work may have Q 's exceeding 100.

Parallel Circuits

When our variable-frequency generator is hooked across the parallel tuned circuit of Fig. 702, we find that at a low frequency the inductive reactance of the coil forms a low-impedance path across the terminals. At a high frequency, the capacitive reactance of the capacitor does the same thing. However, there is one frequency, again the resonant frequency, at which the two reactances are equal; at this frequency there is a high impedance to the flow of current from the line through the parallel tuned circuit.

Fig. 706 shows the impedance of a parallel tuned circuit. Note that it is almost an exact replica of the current-curve of the series tuned circuit.

The *why* of this sharp increase in impedance at resonance is wrapped up in the fact that the currents through the inductive and capacitive branches of our parallel tuned circuit are 180 degrees out of phase with each other. While the current is flowing from top to bottom through the coil, it is flowing from bottom to top through the capacitor, and *vice versa*. Actually the current is oscillating back and forth through the tuned circuit like the balance wheel of a watch, and this current and the voltages it produces *are so timed* that very little current from the line is able to flow through the circuit.

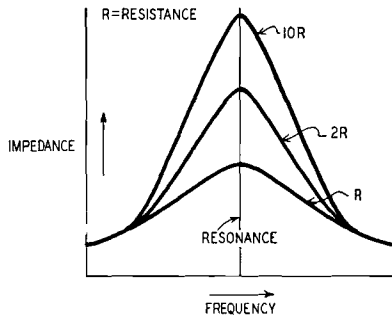

Fig. 706—Resistance lowers Q of parallel tank.

Assume that the generator has built up a negative peak voltage on the top plate of the capacitor in Fig. 702. As this voltage begins to subside, the capacitor charge starts to force current through the coil and develops an expanding magnetic field about that coil. During the next quarter cycle, when the line voltage begins to build toward a negative peak voltage on the bottom plate of the capacitor, the collapsing magnetic field of the coil forces a counter e.m.f. of its own onto this plate to buck out the voltage from the line. When the line voltage reverses itself and rushes around to the top plate again to see if it cannot get its foot in the door there, this counter e.m.f. is right back there to slam the door in its face; and as long as the circuit is tuned to resonance, this exasperating voltage produced by the oscillating current within the tuned circuit is never caught napping.

The whole thing is similar to, and about as frustrating, as, patting a mirror. No matter how nimbly you move, that other guy behind the glass always meets your outstretched palm with the flat of his own hand!

There are just two ways to cross up this bar-the-door-they're-coming-in-the-window routine: One is to detune the circuit and thus

throw off the timing of the oscillating current so that the line voltage can sneak some current through. The other is to weaken the voltage produced by the oscillating current by placing a resistor across the circuit. The current that flows through the resistor is dissipated in the form of heat and so is "lost," and the remainder of the circulating current is not sufficient to produce a voltage great enough to buck out the line voltage. This effectively reduces the resonant impedance peak of the circuit as is shown in Fig. 706. Sometimes we deliberately "load" a parallel tuned circuit with a resistor to make it present a more uniform (but lower) impedance to an extended range of frequencies.

While an unloaded parallel tuned circuit draws very little current from the line, the circulating currents inside the circuit itself are usually high, being many times the line current.

To review: in a series tuned circuit at resonance, the current and the applied e.m.f. are in phase; the current is maximum; the impedance is minimum, equal to the ohmic resistance, and resistive; the voltage across the inductor is equal and opposite in sign to that across the capacitor; and both of the latter voltages are greater than the applied e.m.f.

In a parallel tuned circuit at resonance, the impedance is maximum and resistive; the current from the line is minimum; the circulating currents between the capacitor and coil are high.

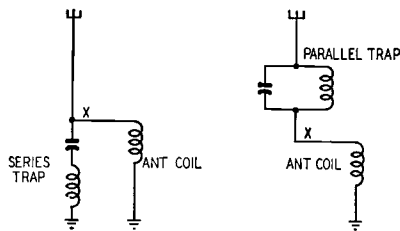

Fig. 707—Tuned circuits employed as wavetraps.

Perhaps their use as wave traps best illustrates the fundamental differences between the actions of the two circuits. Fig. 707 is an example. At 707-a, the series trap forms a very low impedance path between the antenna lead and the ground at its resonant frequency, while it presents a higher impedance to all other frequencies and forces them to pass through the antenna coil to reach ground. At 707-b the parallel tuned circuit in series with the antenna lead says "thou shalt not pass" to its resonant frequency, but it presents little or no obstacle to the passage of all other frequencies. The kind of guy who wears both belt and suspenders and never wants to be half safe could use both of these circuits to get rid of a single unwanted signal. (Not a joke—sometimes it's necessary!) The parallel circuit would keep most of it from reach-

ing point X, and the series circuit would bypass the rest to ground.

To “tune” our tuned circuit, or vary its resonant frequency, we must vary either the inductance or the capacitance. Mechanically, it being usually easier to use a variable capacitor with a fixed inductance, that is the most common type of tuned circuit. However, by changing the core material of the coil, we can vary its inductance and therefore “slug-tuned” circuits are becoming more and more common. A coil tuned with a movable slug is shown second from right in Fig. 708. The same illustration shows a number of tuned circuits.

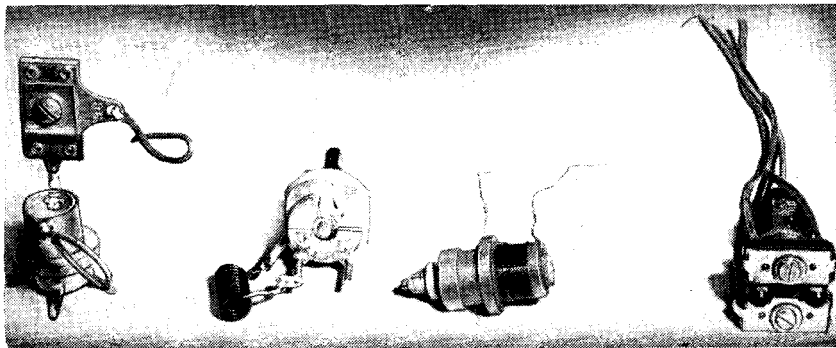

Fig. 708—Typical tuned circuits wavetraps, high-frequency receiver tank, slug tuner, transformer.

The thing to keep clearly in mind is that tuned circuits permit you to single out a particular frequency and lead it down an irresistible path or to throw an insurmountable barrier across its way. You are the boss!

Chapter

8

Transformers—How They Work

VERY few drivers do not understand why there is a gearshift in a car. You know it provides a choice between speed *or* power. Where the highway is smooth and level, high gear hustles the car along at a good gait without the application of much torque to the rear wheels and without racing the motor; but when climbing a hill or plowing through sand, low gear sacrifices speed to provide the driving wheels with increased rotating power.

What the gearshift transmission does for the automobile designer, the *transformer* does for the electrical engineer: it enables him to *transform* a given a.c. voltage to a higher voltage at a lower current, or to a lower voltage at higher current. Notice that voltage and current act like two kids on a seesaw: when one goes up, the other goes down.

This handy device for stepping voltage up or down is really very simple in construction. It consists of two coils so arranged physically that the magnetic field produced by passing an alternating current or a pulsating direct current through one of the coils (called the *primary*) also surrounds the turns of the other coil (called the *secondary*). The medium through which the magnetic field passes in *coupling* the two coils together is called the *core* of the transformer.

Fig. 801—How an r.f. transformer looks in radio diagrams. Note that while the primary is supposed to have 2 turns and the secondary 6 turns, the schematic does not show the exact number. The dashed lines represent magnetic lines of force. Not all of these lines of flux reach from the primary to the secondary.

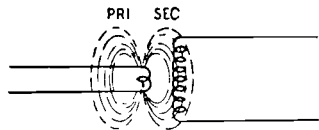

Fig. 801 is a diagram of a simple air-core transformer. When we apply an a.c. voltage across the primary, the variations of current produce an expanding contracting magnetic field about the coil. The lines of force of this field will be constantly swishing back and forth through the turns of the secondary coil. We know that when moving lines of force are intercepted by a conductor, a current is generated in that con-

ductor. The frequency of the current generated in the secondary is the same as that applied to the primary, but the voltage and amount of current available depend upon other factors.

Note in Fig. 801 that only some of the primary lines of force are intercepted by the secondary. Not much can be done to correct this without introducing other more serious losses in transformers which operate at radio frequencies. But, at audio and power frequencies, winding two coils upon a common iron core means that practically all the magnetic field produced by the current through the primary acts upon the turns of the secondary.

This is true because a magnetic line of force feels very much "that way" about soft iron, and it never passes through air if a soft-iron path is available. Consequently, as is shown by the dashed-line path of Fig. 802, practically all the magnetic field produced by the primary is confined to the iron core, which it threads through to act upon the secondary. What is more, the intensity of the magnetic field produced by the current flowing through the primary is greatly increased by the iron core, as we learned when studying inductance.

Transformation Ratios

When a dog scratches fleas, he scratches himself as well as the fleas. The magnetic field produced by the primary of a transformer does about the same thing. Not only does it act upon the turns of the secondary, but it acts upon the turns of the primary as well and produces a back e.m.f. (voltage) that is nearly equal to the applied voltage producing the field. In fact, if there were no losses, it *would* equal the applied voltage, and no current would flow.

Watch closely now, we are going to do a little tricky but true reasoning. If we applied 10 volts across a 2-turn primary, and if the magnetic field produced developed a counter-e.m.f. of nearly 10 volts, would it not be safe to say that every primary turn cut by this magnetic field produced very nearly 5 volts of back-electromotive force? Suppose, then we have a 6-turn secondary. Since the same magnetic field that produces the counter-e.m.f. in the primary is also working on the secondary, is it not logical to expect to find close to 5 volts per turn, or 30 volts across a 6-turn secondary? Well, that is exactly what we do find; and all of this leads up, after a little reflection, to a general statement: *the ratio of primary to secondary voltage of a transformer is practically equal to the ratio of the number of turns of wire in the two windings.*

For example, if we have 100 volts across a 100-turn primary, we will find 10 volts across a 10-turn secondary and 300 volts if the secondary has 300 turns.

Without the resistor in place across the secondary of Fig. 802, we should find our ammeter in series with the primary showing very

little current, for the counter-e.m.f. would keep much current from flowing. But if we insert a low resistance across the secondary so that considerable current flows through it, we find our primary current greatly increased. Why is this? With no actual conducting path between the two windings, why does the current in the primary rise in sympathy with the increase in secondary current?

The answer lies in what happens to the magnetic flux passing through the core. When no current is being drawn from the secondary, this flux produces a bucking e.m.f. (electromotive force or voltage) that holds the primary current down to a very low level.

Don't hurry past this bucking e.m.f.—it's the important part of the story! The magnetic field which produces an e.m.f. of nearly 5 volts per turn in each turn of the secondary also produces a voltage of almost 5 volts per turn *in the primary itself*. But a field set up around any winding by a changing voltage across it (current through it)

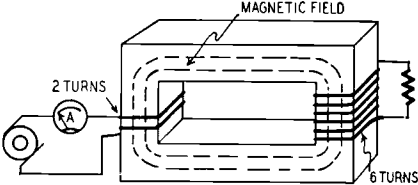

Fig. 802—Step-up transformer with iron core.

produces in the same winding a voltage which opposes the original voltage which set up the field (Lenz's law). If there were no losses in the transformer, that counter-e.m.f.—or voltage if your preference—would be exactly as strong as the line voltage and no current would flow. But all wire has resistance, and there are losses (which we will discuss later) in the best designed core. So we do have a small flow, called the *magnetizing current*.

However, when current flows through the secondary winding, that current produces a magnetic field of its own that *opposes* and partially cancels the magnetic field of the primary. Since the counter-e.m.f. of the primary depends upon the strength of its own field, a reduction in this field means a lowered back-e.m.f. and a consequent increase in primary current.

It is a cardinal principle of physics that "power out equals power in—less losses." Power in electricity is measured in watts, the product of volts and amperes. Mull this over a bit and you will see why, for a given power input to the primary, the current in the secondary goes down as the voltage goes up. Suppose we put in 50 watts to the primary of our transformer and ignore losses. That means that we have 50 watts available in the secondary. We can take our 50 watts in any com-

bination of volts and amperes whose product is equal to 50. For example, we can have 10 volts at 5 amperes, 50 volts at 1 ampere, 100 volts at 0.5 ampere, and so on.

Evidently, any increase in the power taken from the secondary results in an increase in the current flowing through the primary. The actual d.c. resistance of the primary is seldom great enough to hold the current down to the current-carrying capacity of the wire, and the counter-e.m.f. or self-inductance of the primary is depended upon to prevent the current from rising too high. If such a heavy load is placed upon the secondary that this counter-e.m.f. is lowered too much, the wire of the primary will overheat and the transformer be destroyed, in spite of the fact that the secondary winding is heavy enough to carry its current safely.

Transformer Losses

We have been ignoring transformer losses about as long as we can, so we may as well take them up here and now. Outside of the small loss due to the resistance of the windings, transformer losses usually take two forms: *hysteresis* losses and *eddy-current* losses.

When an a.c. voltage is impressed across the primary of a transformer, it produces in the iron core a magnetic field which reverses direction at twice the line frequency. Under the compulsion of this field, the atoms of the core have to keep shifting their position through 180 degrees to have their individual fields lined up with the reversing polarity of the primary field.

Now magnetic substances possess a quality that might be termed *magnetic inertia*, for they tend to retain any magnetism they have once acquired, and it takes energy to get rid of it. The magnetism in such a substance—because of this inertia—always lags behind the magnetic force trying to change it. This resistance to magnetic change is called *hysteresis*, and the energy expended in overcoming it is called *hysteresis loss*. This loss appears in the form of heat developed in the core material.

In some materials the molecules permit themselves to be flipped around with comparatively little resistance, while others are harder to change than bad habits. Hard steel has a high hysteresis loss, while annealed silicon steel has a comparatively low one. This explains why silicon steel is the favorite transformer core material.

Eddy Currents

If we used a solid steel core like that of Fig. 802 for our transformer, the closed core would act as a single-turn secondary and have a low voltage induced in it by the varying magnetic field passing through it. This would produce circular currents—which would flow at right angles to the main magnetic field—in the core, as shown in

the cross section of Fig. 803. These currents would be very large because of the low resistance of the large cross section of the core material. They would heat the core and waste energy. Such currents, because of their circular direction, are called *eddy currents*.

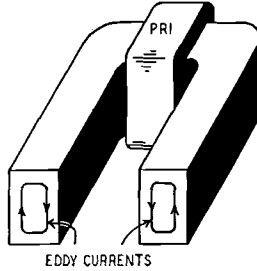

Fig. 803—The path followed by eddy currents.

To reduce eddy currents, the core is built up of thin sheets of metal insulated from one another, as shown in Fig. 804. Eddy currents still exist in each separate lamination, but because the cross section of the lamination is small and the silicon present adds to the resistance to current flow, the eddy currents in the individual laminations remain comparatively puny—so puny, in fact, that the sum of all the little eddy currents does not add up to anything like the big papa eddy current we had with the solid core.

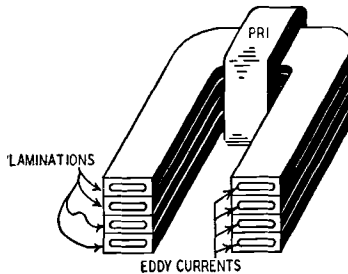

Fig. 804—Laminations reduce the flow of eddy currents.

As the frequency is increased, eddy-current and hysteresis losses go up; that is why we find air-core transformers being used at radio frequencies. In some cases a special form of powdered-iron core—made up of very minute particles of iron insulated from each other and glued together—is used as the core for radio-frequency transformers. If the core is adjustable, it can be slid in and out to vary the inductance of the coil and tune the circuit.

The radio engineer can do almost as many things with a trans-

former as a woman can with a bobby pin. He uses it to step voltages up and down, to transfer an a.c. voltage from one circuit to another without disturbing the d.c. components in the two circuits, to provide a low-loss coupling between two different impedances. Isolation transformers are becoming popular for providing the radio technician with a 117-volt line current that does not have one side grounded, as is shown in Fig. 805. This is very useful in working on a.c.-d.c. receivers that employ one side of the line for B-, since it reduces the chance of shock.

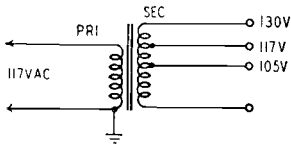

Fig. 805—The isolation transformer frees circuits from the electric light system ground. An isolation transformer is a sensible safety measure.

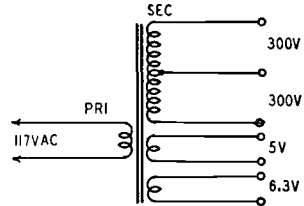

Fig. 806—Several windings may be combined on a core, as in this power transformer.

A common requirement in a radio receiver is to have two separate low voltages for heating the filaments of the tubes and a high voltage for use in supplying the B-voltage. Instead of using three transformers, we can use a single transformer with three separate secondaries, as diagrammed in Fig. 806.

Transformer Troubles

The main troubles encountered in transformers are open windings, shorts between windings, shorts between turns of the same winding, and shorts between a winding and the core. If a single turn is shorted, very heavy current flows through it and quickly develops a great deal of heat, damaging the insulation of neighboring turns and producing more shorted turns. However, if a well-built transformer is not subjected to overload; if voltage surges, such as are produced by lightning, are not allowed to enter the primary; and if insulation-destroying moisture is kept out, a transformer is a highly efficient, trouble-proof electrical device.

While we have touched on several different phases of transformer action, the subject is by no means exhausted. We will return to it later when studying such special cases as i.f. transformers, in which both the primary and secondary windings are tuned to the a.c. frequency being passed.

In the next chapter, though, we are going to see what happens to this electron we have been hounding through coils, capacitors, and resistors when it enters the vacuum tube. Do not miss this special attraction!

Chapter

9

The Diode Vacuum Tube

HAVING spied on the busy electron while it skipped through conductors, resistors, coils, capacitors, and transformers, you may feel that you are an authority on the behavior of the little cuss; but until you have observed one doing its stuff inside a vacuum tube, you

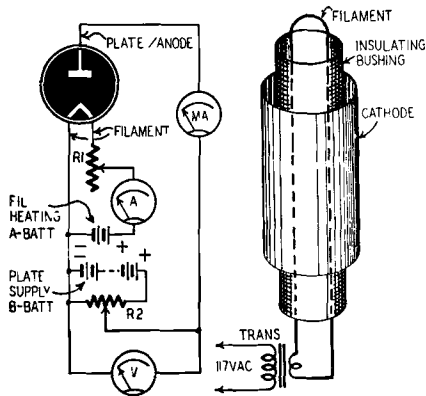

Fig. 901 (left)—Test setup illustrates diode action. Fig. 902 (right)—Cathode is cylinder surrounding the filament.

really have little idea of the power and versatility packed into one of these tiny charges of negative electricity.

Take a look at the experimental setup diagrammed in Fig. 901. The circle represents a hollow glass sphere in which are contained a couple of loops of resistance wire and a small metal plate mounted near to, but not touching, this wire. Leads are brought out from the plate (sometimes termed the anode), and from both ends of the "filament" wire, and all the air possible has been pumped from the glass bulb before sealing it.

A low-voltage battery, (called an "A" battery) an ammeter, vari-

able resistor R1, and the filament are connected in series. Another, higher-voltage battery, (called a "B" battery) with its negative terminal connected to the negative terminal of the filament battery, has variable resistor R2 bridged across it so that any positive voltage from zero (at the extreme left-hand position) to the full battery voltage (at the extreme right-hand position) may be selected by the moving slider. A voltmeter is arranged to read this voltage. The slider connects through a milliammeter to the plate of our "vacuum tube."

With the slider of R2 set at zero positive voltage (extreme left), let us slowly decrease the resistance of R1, permitting more and more current to flow from the "A" battery through the filament. The passage of this current produces heat in the filament wire; and when enough current flows, the wire becomes red hot. Our ammeter reveals how much current is flowing through the filament, but our milliammeter still stands at zero. However, if we move the slider of R2 to the positive end of the battery, the milliammeter indicates *pronto* that current is passing through it!

Where does this current come from? It must be flowing from the high-voltage battery, but where is the complete circuit? Surely the current cannot pass through the space between the filament and the plate inside the glass sphere, for we have always thought of a vacuum as being a perfect insulator; yet, there is no other logical explanation of what that milliammeter pointer is saying. The current *must* be bridging the gap inside the bulb, but how?

Remember that back in Chapter 1 we found there are always a number of free electrons wandering aimlessly around through any conducting material? By applying voltage, we can control the direction and speed of this movement of electrons to a certain degree; but even with no e.m.f. applied, the restless little jiggers are constantly hopping around from one atom to another.

When they come to the surface of the conductor, however, they bump into a force, somewhat resembling the surface tension of water, that keeps them from passing through. While they possess some *kinetic energy* (kinetic energy is power acquired through motion; it is the reason a soft hand can slap so hard), they do not have enough to shoot through this surface barrier. They must have help if they are to escape into "the wild blue yonder."

Providing heat is the easiest way to supply this help. When the temperature of a body is raised, free electrons begin to feel freer and friskier by the second. They start to accelerate and to shoot madly about like a bunch of water bugs playing tag, and sooner or later one of them takes a long running jump and pops right through the surface of the body into the air or vacuum surrounding it. As the temperature goes still higher, more and more of these heat-propelled electrons make the grade until finally the heated object is surrounded by a veritable cloud of fugitive particles that it has *emitted*.

Please note that it makes no difference *how* the emitting body is heated. It could be done with a blowtorch, a gas flame, the focused rays of the sun, etc., but inasmuch as the emitting material must be heated inside a vacuum in our radio tubes, the heating effect of an electric current has proved to be the most practical.

Sometimes the filament itself is the emitting body (or cathode), as is the case in Fig. 901; but in other instances the emission is from an *indirectly heated cathode*, as is shown in Fig. 902. Here the filament is heated by current from an alternating-current transformer, and this heat passes through a bushing made of electrically insulating but heat-conducting material and raises the temperature of the sleeve-like cathode to the proper temperature for emission. Tubes are therefore loosely divided into "filament" and (indirectly heated) "cathode" types.

When an electron is emitted, its negative charge is subtracted from the total charge of the emitting body; therefore the body becomes unbalanced in a positive direction, tending to attract the negative electron back into itself if some other stronger force is not exerted on that negative particle. That is where the plate in our vacuum tube enters the picture. If the plate is positively charged with respect to the emitting filament, it tends to attract to itself the electrons that have escaped into the vacuum; and when there is a constant parade of electrons from the filament or cathode of a vacuum tube to the plate, we have a *plate current*.

These electrons pass from the plate to the positive terminal of the battery through the milliammeter, causing it to deflect. Incidentally, when only 10 ma is flowing, 6.28×10^{16} electrons are being emitted by the filament and attracted to the plate every second. However, the electrons flow from the negative terminal of the battery into the filament at the same rate at which they return to the positive terminal *via* the plate; so no electrons are really lost or gained.

Now that the mystery of how current can flow through a vacuum has been cleared up, let us do a little more experimenting with the apparatus shown in Fig. 901. Suppose R1 is adjusted until our filament just begins to glow a dull red and that R2 is then manipulated so that the voltage applied to the plate starts at zero and advances in 10-volt steps. At each step, let us carefully note the values of the plate voltage and the plate current.

Next, let us increase the current through the filament until the filament is a bright cherry red, and then let us repeat our step-by-step increasing of the plate voltage, again carefully noting the changes in the readings of the voltmeter and the milliammeter. Finally, let us combine the results of these two observations in one graph, Fig. 903.

From this graph we can see that as the plate voltage increases, the plate current for the low-filament-current condition also increases, rapidly at first and then leveling off until a further increase in plate voltage produces practically no increase in plate current. The same

thing is true after we have increased the filament current, but now the leveling-off point occurs at a higher value of plate current. For low plate voltages, the plate current is practically the same for high or low values of filament current.

The total number of electrons emitted from the filament depends upon its temperature, which in turn depends upon the current passing through it. The total number of electrons attracted to the plate depends upon, first, how many are emitted by the filament and, second, what percentage of these the attraction of the plate voltage can win over from the attraction of the filament itself. The higher the plate voltage, the higher is this percentage.

When our filament glowed a dull red, a limited amount of electrons were released. When the plate voltage was low, only a small number of these could be attracted to the plate instead of returning to the filament; but as the voltage, and consequently the attraction, of the plate went up, more and more of the available electrons succumbed to its siren call until finally it was getting *all* of them. Beyond this point, an increase in plate voltage obviously could not increase the plate current.

When we increased the filament current and raised the temperature of the filament, we increased the number of electrons emitted. Under these conditions, it was necessary to raise the plate voltage still higher before it was attracting the total increased output of the filament. It is apparent that for every value of filament current there is a certain value of plate voltage which will attract *all* the emitted electrons and beyond which no further increase will result in more plate current. This maximum current is called the *saturation current* of the tube, and it is important that the tube be so designed that this saturation condition is never reached with the normal values of filament current and plate voltage that are applied.

Why the Vacuum?

Perhaps you are wondering why there is a "vacuum" in vacuum tubes. Emission *will* take place in the open air, but there are two good reasons for placing our tube elements inside a vacuum. In the first place, if the filament were heated red-hot in the open air, it would oxidize quickly and be destroyed. In the second place, if the space between the filament and the plate were not emptied, the poor little electron would have a tough time trying to shoulder its way through the bulky atoms of air and gas which have a mass some 1,800 times that of its own.

The two-element tube that we have been studying is a fundamental type, as we shall note in the next chapter, yet this *diode*, as it is called, is used in some form or other in nearly every radio and television set on the market today. Diodes, like people, come in all sizes

and shapes. Some of them are glass-type tubes, which others are metal.

Diodes are subject to practically all the ills suffered by their more complicated brethren. If the filament breaks, we have no way of raising the temperature to the emitting point; and "open" filaments are one of the most common causes of tube failure. It is equally obvious that if any two elements, such as the filament and plate, actually touch each other, the tube cannot function normally. This "shorted element" route is one by which many tubes reach the junk pile.

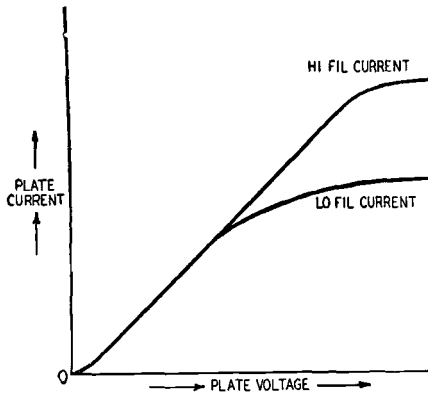

Fig. 903—Hotter cathode emits more.

As was pointed out before, the operation of the tube depends upon the elements being housed in a good vacuum, and anything that impairs this vacuum will ruin the operation of the tube. Occasionally minute amounts of gas remain in the tube or escape from some of the elements after sealing; then the tube becomes "gassy." Gassy tubes cause many headaches in the radio repair business, for they are not always as easy to detect as other defective types.

Even under normal conditions, the electron emission of a filament or cathode will fall off after a while, and this deterioration will be speeded up if the tube is subjected to overloads. Such reduced emission results in the "weak" tubes indicated by a tube tester.

Poor connections between the leads and the tube elements can result in "noisy" tubes that make a rasping, static-like sound in the speaker; and if the various elements are not held rigidly in place, the tube will often make a ringing sound come from the speaker when the tube is touched or bumped. Such tubes, because they behave like a microphone, are called "microphonic."

AS pointed out in Chapter 9, the Father Adam of all electronic tubes is the two-element diode. One of the elements, the plate or anode, is simply a piece of metal without any special fussiness in its make-up. But the other, the cathode (or filament), is the key element in almost every electron tube—no matter how complicated it may be—because the electrons boiled out of it make up the emitted current that goes through the tube. In tube design the cathode material is extremely important, so let us dig a little deeper into the subject of cathodes.

In most tubes, the only way to make a cathode emit is to heat it. As with incandescent lamps, tungsten is the only wire that can stay hot enough to emit any practical quantities of electrons without melting. Pure tungsten filaments are used in many large transmitting tubes; they are heated to a dazzling white—to 2,000 degrees C.

Tungsten, while it stands up under heat, is not the best emitting material, and therefore many medium-sized transmitting tubes have tungsten filaments coated with thorium. These *thoriated* filaments liberate plenty of electrons when they are heated to a bright yellow—about 1,700 degrees C.

But the filaments or cathodes of most radio and TV receiving tubes are coated with a mixture of barium and strontium oxides on a nickel-alloy base. They need be heated to only approximately 700 to 750 degrees C to make enough electrons to boil out.

There always has to be a villain in the piece though, and the mustache-twirler of electron-tube current flow is the *space charge*. Picture the stage set for plate-current flow: the filament is heated and a positive charge from the B-battery or power supply is connected to the plate. Some of the electrons emitted from the cathode are pulled across to the plate by its positive charge. But other emitted electrons are not reaching the plate because the B-voltage simply isn't high enough; and they are just standing around between the filament (or cathode) and the plate doing nothing. This little cloud of not-so-innocent bystanders is called the space charge; being composed of electrons, it is charged negatively.

Now, as the heat of the cathode boils out more electrons from its surface, the space charge tries to push these electrons back onto the cathode—the negative space charge repels the negative emitted electrons. The positive plate is shouting, “Come on over!” to the electrons, but the space charge is commanding. “Get back on that cathode!” The space charge is nearer the cathode than is the plate, so the newly emitted electrons feel the effects of the space charge much more than those of the plate. Result: fewer electrons get to the plate and plate current is low.

One way to cut down the bad effect of the space charge is simply to cut down the distance between cathode and plate. In the 25Z6, for instance the cathode and plate are only .02 inch apart. Another way is to put a little mercury in the tube. When the filament heats, the mercury vaporizes and becomes a gas. When an electron on its way to the plate hits a mercury-vapor atom, it knocks loose one of the mercury atom's electrons. This electron promptly beats it over to the plate like a little boy at the end of a school day. The mercury atom now is missing one electron. Looking around, it discovers the space charge and snatches an electron from it. The mercury atom is whole again—and electrically neutral—but by gobbling up that electron from the space charge, it has reduced the space charge and aided the hard-working plate to attract a larger current.

Enter the Triode

The early radio engineers, viewing this steady flow of electrons from cathode to plate, began to feel like small boys watching the stream coming out of a garden hose: they wanted to stick something into the current and see what would happen. The something they inserted was a *grid*, and that is how the *triode* tube was born.

The grid is a mesh of fine wire wound around supports so that it surrounds the cathode. The drawing of a broken-open triode in Fig. 1001 shows the grid wires plainly. The drawing also shows the element structure of a typical triode vacuum tube.

The *control grid*, as its full name goes, is usually *biased* negative with respect to the cathode; that is, a negative d.c. charge is permanently placed on it. Sometimes a small battery is used, at other times the negative terminal of an a.c.-operated power supply, and in still other cases other methods are brought into play. But the net result is that the grid is more negative than the cathode.

If the grid were positive, it would act somewhat like another plate—it would attract electrons, and there would be a grid current just as there is a plate current. Although the grid is positive in a few rare circuits, it is negative in most applications and does not attract any of the emitted electrons to itself.

Like a water-logged life preserver, a negative grid not only is no

help, it is a hindrance—it not only does not pull electrons away from the cathode but pushes them back!

So here we have the plate pulling electrons from the cathode and the grid pushing them back on. The question is: who has the most to say in this war of purposes? Answer: the grid. Reason: because it is so much closer to the cathode than is the plate.

When the grid goes negative, it is like a traffic policeman putting up his hand—traffic slows down or stops, as desired. When it goes more positive (or less negative), you can imagine the policeman vigorously motioning all the cars to move on. When the *plate* voltage changes, however, it's as though a policeman 10 blocks away were directing the traffic. There is some effect on the electron traffic around the cathode but not much.

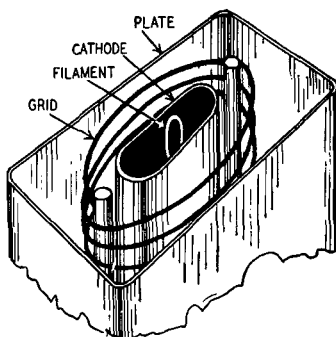

Fig. 1001—Arrangement of cathode and filament, grid, and plate in triode tube.

When the grid does become less negative and lets the plate pull electrons away from the cathode, the electrons pass right through the spaces in the grid mesh, just as the cars in traffic go by the policeman.

With all this in mind it is easy to see why the grid voltage has much more effect on the plate current than the plate voltage has. To state it another way, a small change in grid voltage produces a change in plate current which could only be duplicated by a much larger change in plate voltage.

You can prove this yourself with equipment no more complicated than that shown in Fig. 1002. The 6J5 is arranged so that both grid and plate voltages can be varied and plate current read on the milliammeter.

Suppose we start with -8 volts on the grid and $+250$ volts on the plate. Because of the construction of the tube, the plate current is 9 ma.

Now we change the grid voltage to -10 . The milliammeter reads 5 ma, which agrees with the idea that making the grid more negative

pushes more electrons back on the cathode so they can't reach the plate. Remember, then, that to decrease the plate current by 4 ma, we had to make a 2-volt change in grid potential.

Now reset the grid voltage to -8 (so that 9 ma is flowing again). This time the object is to see how much the *plate* voltage must be changed to get plate current down to 5 ma. So we vary the plate-

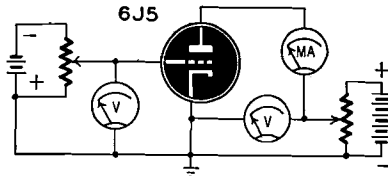

Fig. 1002—Test setup shows μ of a triode.

voltage control until the current is 5 ma. A look at the plate voltmeter shows 210 volts. Note that a 40-volt plate-potential change was necessary to get the same effect on the plate current as was obtained with only a 2-volt grid change! The ratio of the two, $40/2$ or 20, is the amplification factor (μ or μ) of the tube.

To make practical use of the tube as an amplifier, however, we must have some way of taking the amplified voltage changes and feed-

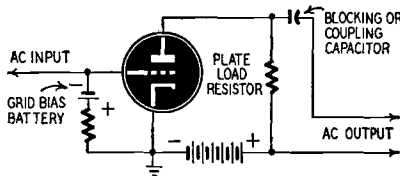

Fig. 1003—A plate load resistor is added.

ing them to other points in the equipment. The plate load resistor in Fig. 1003 is the part that solves the problem. As the plate current changes because of grid-voltage changes, the current rising and falling through the resistor creates a changing voltage drop across it. If the tube is operated correctly, the voltage changes across the load duplicate exactly the voltage changes at the grid, except that they are much larger.

They are *not* 20 times as large, though—there's a fly in the ointment. Every time the plate current rises, the drop across the resistor rises too . . . it must to furnish output. But the voltage on the plate is now less because much less than the full battery voltage reaches the plate. Of course, the lessened plate voltage does not entirely nullify the effect of the more positive grid voltage, because, as you remem-

ber, plate voltage is not anywhere near as effective in controlling the tube as is grid voltage. It does cut down the amplification somewhat, however, and, depending on the values of resistance and voltage used, the output voltage is only about 14 times the input.

There is one point to get straight: the tube does not take the input voltage and stretch it in some mysterious way to get a bigger output. The tube really does not amplify at all! It is a *control device*. It works similarly to the filling station hoist that sends your car up in the air so the garageman can work underneath it. The attendant works a little valve—and presto! your 3,000-pound automobile rises before your eyes. It isn't the attendant's hand that does the work, of course. It's the compressed air stored in a tank, released in the desired quantity by the little hand valve.

A vacuum tube is just like the little valve and the plate or B-battery like the stored compressed air. The incoming signal on the grid simply releases and dams up the stored electrical energy in accordance with its desires. There is no grid current, so no power is taken by the grid either from the batteries or from the controlling input signal. The output voltage—every bit of it—is energy from the B-battery. If there were no grid signal, there would just be a steady d.c. voltage across the load resistor. There would be no output because the capacitor prevents d. c. from passing. But when the grid signal starts alternately repelling and passing electrons, the d.c. across the resistor rises and falls with the plate-current changes. That gives it an a.c. character, and it passes through the capacitor.

The Screen Grid

You remember that, while the amplification factor of the 6J5 is 20, we could get a real amplification of only 14 times in the practical circuit of Fig. 1003 because plate-voltage changes gummed up the works. The cure is to add another grid to the tube. Called the *screen grid* (or simply screen), it is located between the control grid and the plate, as in Fig. 1004.

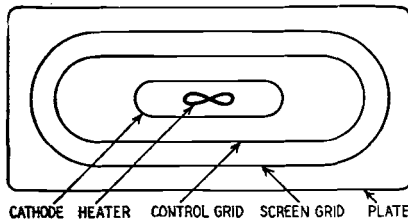

Fig. 1004—Screen between grid and plate.

The screen operates at all times with a positive voltage on it, a voltage about half that of the plate (more or less). The hookup ap-

pears in Fig. 1005. The screen voltage is fixed and does not vary with the plate current. because it is positive, it helps the plate attract electrons from the cathode; most of the electrons, however, pass through the screen wires and got to the plate—screen current is very small.

Now the tube works just as before, with this exception: while the plate voltage changes periodically (just as it did before), the screen voltage does not. And because the screen is closer to the electron source (the cathode) than the plate, its pulling power is greater. As a result, the plate voltage changes don't have anything approaching the

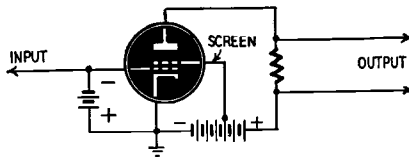

Fig. 1005—Circuit of a tetrode amplifier.

effectiveness they had before in cutting down amplification. Even when the plate voltage is low, there is almost as much positive force pulling electrons through the tube as when the plate voltage is high. The amplification of a *tetrode*, as this tube is called, is many times higher than that of a simple triode.

Another advantage of the screen is its reduction of grid-to-plate capacitance. Those two elements form the plates of a small capacitor through which some of the tube's output can feed back to the input, especially at higher frequencies. *Feedback* can produce all kinds of hair-raising effects, as we will find later on, but the screen grid, placed right in the middle of the grid-plate capacitance, breaks it up by acting like a shield or screen (hence its name) and reduces the capacitance (which may be several micromicrofarads in a triode) to something less than .01 μf in the tetrode.

In the next chapter we will take a quick glance at a couple of more tube types and then wade into tube characteristics. Knowing the characteristics of a tube is just like having a trusted friend give you the lowdown on a coming blind date: it tells you exactly what kind of a performance you can expect!

The Pentode Vacuum Tube

MORE than 20,000 miles a second! That's the speed at which an electron hits the plate of the tetrode described in Chapter 10. No wonder that the terrific impact of the speeding electron knocks other electrons loose from the plate. It's like throwing an apple at an apple tree; if you throw hard enough, a whole shower of fruit falls to the ground.

Secondary Emission

Up to now the only emission we have run into was that from the cathode, caused by heat, but now we have electrons emitted from the plate—and without any heat at all! This kind of knock-'em-loose emission is called *secondary emission* because it can't take place until a "primary" electron from the cathode comes along to do the knocking.

Secondary emission in a triode bothers no one. The plate is usually the only positive electrode in the tube and its irresistible fascination for the negative secondary electrons pulls them right back where they came from. The negative grid helps to shoo them on their way.

But the tetrode is a different story, for the screen is also positive, and some of the secondary electrons are attracted to it. The plate actually loses electrons to the screen. This wrong-way traffic is just about as upsetting inside our tube as it would be on a one-way street. Collisions occur between the "in reverse" electrons and those emitted from the cathode; furthermore, electrons arriving from the cathode are repelled by the cloud of secondary electrons surrounding the plate.

The graph of Fig. 1101 shows these upsetting effects. The curves show how plate and screen currents vary when the plate voltage is changed. During the experiment, the screen is held at 80 volts. The test circuit appears in Fig. 1102. Beginning with zero plate voltage (potentiometer arm at ground end), plate current is zero. There is screen current, because the screen is 80 volts positive and acts like a plate.

Now we run up a little plate voltage, say about 10 volts. There is a little rise in plate current and a little drop in screen current because some of the electrons from the cathode are reaching the positive plate instead of going to the screen. The attraction of the plate is not great enough to make them travel really fast, so they dislodge no secondary electrons from the plate.

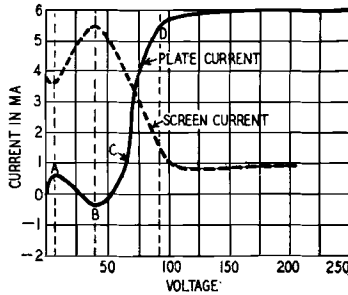

Fig. 1101—Curves show tetrode behavior.

As the plate voltage rises above the 10-volt level, however, the electrons speed up and a few secondary electrons are knocked off the plate. Remember that the total plate current is made up of the electrons that reach it from the cathode *minus the secondary electrons grabbed by the screen*. As the plate voltage rises, the speed gets higher and higher, knocking off more and more secondary electrons for the screen to steal. As the graph plainly shows, the net plate current

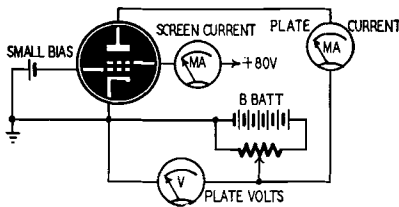

Fig. 1102—Circuit for obtaining tetrode curves.

between voltages A and B actually gets *less* as the plate voltage rises, and the screen current increases! After a while, in fact, the impact of primary electrons is so great that each one of them knocks loose *several* secondary electrons from the plate. This is clearly a losing proposition—the plate is giving up more electrons than it is getting. So, as the solid curve shows, not only does the net plate current go down to zero, but it actually flows in the wrong direction. We indicate

this topsy-turvy state of affairs by showing “negative” (wrong-direction) plate current.

As the voltage is increased beyond point B, the growing attraction of the plate begins to enable it to hold its own against the siren call of the screen. A higher percentage of the secondary electrons commence to fall back onto the plate instead of going to the screen grid, and the plate current starts to increase again. At point D the plate has become positive enough to put an end to the screen’s theft of its electrons, and it reclaims *all* of its emitted particles. From this point on, the plate current is little affected by the plate voltage. The screen and control grid voltages, determine the plate current, as we learned in Chapter 10.

If the plate voltage always stayed in the region beyond point D, secondary emission would cause no trouble; but when a tube is working in a circuit, the plate current is constantly changing. By the same token, so is the plate voltage, because of the varying drop across the plate load resistance. (See Chapter 10.) In fact, when the grid is driven strongly positive, the plate voltage may dip *below* the screen voltage.

When this happens, we have lost a good bit of our ability to control the plate current solely with the grid signal; for, as we have just seen, a change in the plate voltage in this lower-voltage region has a very decided effect on the plate current on its own hook. If we are to avoid the bad effects of this double control, we must either keep signal voltages very small so that the plate voltage will not swing down near the screen voltage, and thus sacrifice a large portion of the tube’s ability to amplify; or we must use a very high plate voltage to ensure the same thing even with increased amplification. What is really needed is some device that will put a stop to this dominance secondary emission gives to plate voltage over plate current.

The Suppressor Grid

Just such a device is the *suppressor grid*, which looks much like the control and screen grids, although the spacing between turns is usually greater. It is found between the plate and the screen and is connected—often inside the tube—to the cathode. This is the fifth element added to our tube, so the family name of *pentode* (*pente* is Greek for five) is given to tube with suppressor grids.

Since the suppressor grid is negative with respect to the plate, it sends secondary electrons right back to the plate instead of letting them pass through its turns to the screen. Control of the plate current is restored to the control grid, even under conditions where the instantaneous plate voltage dips below the screen voltage. In power output tubes, such as the 3V4 and the 6K6, this means higher power output with lower grid-driving voltage; in tubes used to amplify radio frequencies, such as the 6SJ7 and the 12SK7, signal voltages can be

amplified tremendously without employing high plate voltages. Fig. 1103 shows how adding a suppressor grid takes the dip out of the plate-voltage-vs.-plate-current curve of the tetrode. Remember that the effect of the suppressor grid on secondary emission is the same as

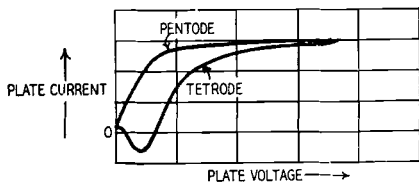

Fig. 1103—Adding suppressor alters curve.

that of a good kissproof lipstick; the act isn't prevented from taking place, but it is kept from causing any trouble!

The Beam Tube

One special kind of tube contains no suppressor but arrives at the same result as the pentode. Fig. 1104 is a cutaway drawing of a

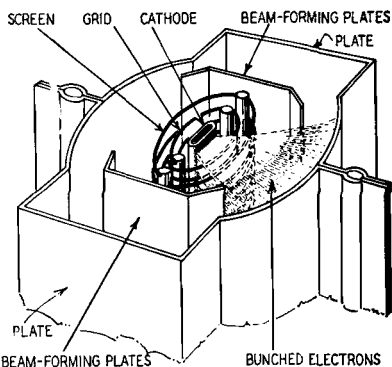

Fig. 1104—Beam tube needs no suppressor.

beam tube, the 6L6. The beam-forming plates are connected to the cathode. The negative beam plates repel electrons so that they are all concentrated in a stream directed at the curved parts of the plate. The plates also prevent any secondary electrons from sneaking over to the screen by the side doors—outside the beam.

As the electron stream goes through the negatively-charged wires of the control grid, the repulsion of these wires molds the beam of electrons into a stack of flat sheets of electrons—sheets that pass between the wires of the screen, too, because the screen wires are

carefully placed so as to be in the "shadow" produced by the negative grid wires.

The sheets of electrons pass between the wires of the screen, which are aligned with the grid wires. Since the electrons do not hit the screen wires directly, the screen takes very few of them and almost all go to the plate where they can do the most good.

The steady voltage on the screen may often be higher than the instantaneous plate voltage, while it is varying rapidly to amplify a signal; therefore, the screen is more attractive to the electrons than is the plate. After the electrons have passed through the screen, this greater attraction slows them up—they are not as anxious to get to the plate as they thought they were! Because of the "braking" action, the slowed-up electrons bunch up between screen and plate, as the heavier dashed lines in Fig. 1104 show. The concentration of electrons results in a negative space charge, a "wall" between plate and grid, which prevents secondary electrons knocked out of the plate from getting to the screen. This electron "wall" works just as effectively as a suppressor would.

Tube Types

We have by no means pumped the well dry on the subject of different types of electron tubes. There are literally hundreds of varieties on the shelves of any well stocked radio store. Many of the differences, though, are produced by mechanical variations in the filament structure, the basing arrangement, or the housing of a single basic type. For example, there are beam tubes with filaments that operate at 1.4, 6.3, 12.6, 25, 35, 50, 70, and 117 volts. Beam tubes come in small, medium, and large envelopes, and the envelope may be made of either metal or glass. If we look at the bases, we will find beam tubes with 7-prong miniature bases, with octal bases, and with loktal bases.

Another flock of types is produced by a kind of electronic grafting, in which two or more basic types of tubes are housed in the same envelope and are built around a common cathode. This method produces some fearsome sounding names, such as "duo-diode-hi-mu-triode"; but that name really describes nothing more awful than a hybrid tube in which two diodes and a high-amplification triode are all clustered around the same cathode inside one envelope.

THE story of a vacuum tube can be told only very superficially in words. We can say how many pins it has, what kind of an envelope, the filament voltage, the number of elements, and the inter-electrode capacitances. But that doesn't give much of an idea of what to expect from the tube when we use it in a circuit. The real questions are:

1. How much amplification (or in some cases, how much power output) can you get under a certain set of conditions?
2. How much voltage (a.c. and d.c.) should be applied to each element?
3. What impedances should be connected to the elements?

These three points are important because they alone determine how the tube will perform electrically, whether it will do a specific job, and how the circuit elements must be chosen for best results in a particular case. They are not easily summed up in a single statement, for they are interdependent; change any one of them and the others change, too.

The best way to show interdependent and variable quantities is in a graph. That is how most tube data is given in manuals.

The usual tube book gives a set of curves like those in Fig. 1201 for each tube. Plate current is plotted here against plate voltage with a separate curve for each value of grid voltage. All voltages are direct. The test circuit used in plotting the curves appears in Fig. 1202. Filament and grid voltages are held constant while the plate voltage is varied. At each plate voltage value the plate current is read. Then the grid voltage is changed and the plate-voltage changes are gone through again and plotted.

To obtain the curves of Fig. 1201, for instance, the grid voltage was set at zero (grid grounded) with the potentiometer, the plate voltage set at various values and the plate current measured at each voltage. Dots were made at these points and the curve drawn. Then the grid voltage was raised to -2 and the same procedure followed with the

new grid voltage. Several of these curves form a *plate family*. The same thing is done with tetrodes and pentodes, with fixed screen voltages. Often screen current is plotted on the same graph, using dashed lines to distinguish it from plate current.

The same information can be given in a slightly different way. Plate current plotted against grid volts, with a separate curve for each value of plate voltage, forms a *transfer* or *mutual characteristic* graph, which gives essentially the same information as a plate family.

Amplification Factor

We learned in Chapter 10 that the *amplification factor*, or “ μ ” of a tube is simply a number telling how many times more effective grid voltage is than a plate voltage change in producing a change in plate current. For example, look at the -4 -volt curve of Fig. 1201. At one

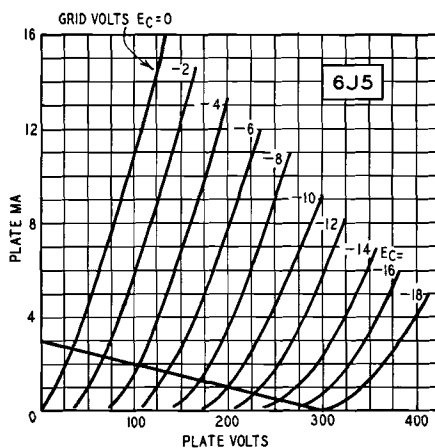

Fig. 1201—Family of plate curves shows performance of the tube graphically.

convenient point the plate voltage is 105 and plate current 2 ma. Now look at the -6 -volt curve. At 105 volts the current is only about 0.2 ma. To get the 2-ma plate current again (keeping grid voltage -6) we have to go to approximately 145 plate volts. A 40-volt change in plate voltage is necessary to restore to its original value a current that was varied by a 2-volt grid change in the opposite direction. The μ is $40/2$, or 20, just as you will find in the book (RCA Tube Manual RC 16) if you look up the 6J5's ratings.

Plate Resistance

The plate resistance of a tube is found by dividing a small change in plate voltage by the change in plate amperage it causes. For example, if we check a number of the curves on Fig. 1201, selecting parts

where they are straightest, we find that changing the plate voltage by 10 or a little less, with grid voltage unchanged, produces a change of 1 ma in plate current. The plate resistance is then $10/.001$ (ampere) or 10,000 ohms. The book gives values between 7,000 and 8,000, so we are a little high. A bigger graph would read more accurately.

Transconductance

Control-grid-plate transconductance or simply *transconductance* or *mutual conductance* (it's called more names than a baseball umpire) is abbreviated g_m and is probably the best value by which to judge how good a tube is as an amplifier. It is defined as "the small change in plate current divided by the small change in grid voltage required to produce it." All other voltages are supposed to remain the same. Since our smallest divisions of grid voltage are a full 2 volts, we cannot readily make this measurement on the chart, though it could be done easily on the actual test setup.

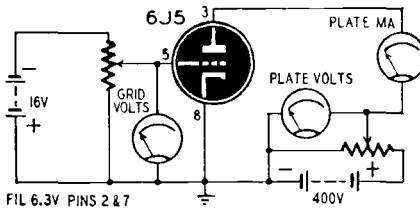

Fig. 1202—Test circuit for making chart.

As an example, if a grid shift of 1 volt produces a change of 2.5 ma in the plate current, the transconductance is equal to $.0025/1$, or .0025 "mhos." The *mho* (ohm spelled backward) is the basic unit of conductance—which is the reciprocal or opposite of resistance.

A handier, pocket-size unit is the *micromho* or millionth of a mho. The transconductance of the 6J5 under typical operating conditions may run between 2,500 and 3,000 micromhos. See how close you can come to it using the graph.

Dynamic Characteristics

The measurements and curves you have seen so far are *static* characteristics, made under standing-still conditions. You get about as much useful information from them as you would out of watching a new driver maneuvering a car in a large deserted lot. By watching him in the lot, you can tell whether he knows what the pedals are for and if he has the strength to turn the steering wheel (and in the right direction!). But none of that information and ability is useful until he gets out on the road and reacts to different—and *changing*—conditions that he will encounter there.

The same is true of the tube. Used in an amplifier circuit, it will encounter impedances not present in the tests; it will deal with a.c. voltages and currents; it will have to adapt itself to changing conditions. A little simple calculation, using ruler, pencil, and paper, will tell us what the tube will do under *dynamic*—moving—conditions, when it is in useful operation as an amplifier.

Suppose we are to use the 6J5 in the simple voltage-amplifier circuit of Fig. 1203. We choose the value of R1 to be 100,000 ohms. C1 is merely a blocking capacitor preventing d.c. from passing into the following stage. A grid resistor in series with the bias battery permits us to place a negative (d.c.) voltage on the grid without any likelihood of shorting out incoming signals.

What will happen in our circuit with the values for R1 and the bias and B-voltages we have chosen? What values are needed to obtain the amplification we want? If we know the answer to the first of this pair of questions, the second question answers itself.

If the bias does not cut off the tube, the plate current causes a d.c. voltage drop in R1; therefore, the plate has *less* than 300 volts on it. The static curves in Fig. 1201 no longer tell the whole story, for, if we choose a certain grid voltage, the chart shows that the plate current depends on the plate voltage—but with R1 in the circuit we don't know what the plate voltage is.

Load Line

The solution is to draw a *load line* on the graph to show just what the plate voltage is for each value of grid voltage, with R1 in circuit.

It's a simple matter of reasoning. If the voltage at the plate is really 300 volts in the circuit of Fig. 1203, there is no drop across R1, which means that plate current must be zero. On the graph, we place a dot at the intersection of 300 plate volts and zero current.

If the plate voltage is zero, the tube must be effectively a dead short between cathode and plate, and *all* the B-voltage is across R1. This never happens in practice (unless the tube has shorted elements, in which case, watch things burn!), but it is useful as a piece of brain-work. If all the B-voltage is across the resistor, we can easily figure the current: $I = E/R = 300/100,000 = .003$ ampere or 3 ma. That means that if the plate voltage approaches zero, plate current approaches 3 ma; and we can dot the appropriate intersection on the graph. Joining the two dots with a line will show the true dynamic characteristic of the tube when it is placed in its circuit.

Note that the value of R1 and the B-voltage determined the placement of the *load line*. Other values would give other lines. The static plate family, on the other hand, is a set of curves that remain the same no matter how the tube is used. We can define dynamic characteristics, therefore, as the characteristics of the tube *in the actual circuit and under the actual conditions in which it is used*.

The load line tells us what the plate voltage, plate current, and grid voltage really are at any time while the tube is working. We need only one to find the other two. If we have a grid voltage of -10 , for example, the plate current is 1 ma and the plate voltage is 200 .

These values are dynamic—they apply just as much to a.c. as to d.c. Suppose we connect an audio generator to the input terminals. Assume for the moment that the bias battery is shorted. The audio signal has a peak amplitude of 10 volts. At its 10 -volt negative peak, the tube's plate voltage is 200 ; when the audio is at zero, plate voltage is 35 . The tube's plate voltage has changed during the half-cycle by $200-35$ or 165 volts. Since the change is at an audio rate, it goes through $C1$ and appears at the output terminals as an enlarged replica (more or less perfect) of the input signal. The enlargement is easy to figure: the input signal was 10 volts peak; the output was 165 volts peak. The magnification, *amplification*, or *voltage gain*, was $165/10$ or 16.5 times. Note that the voltage gain, like other dynamic characteristics, depends on the circuit used.

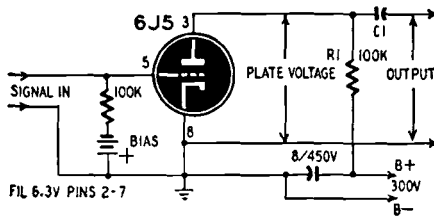

Fig. 1203—A typical 6J5 voltage amplifier.

The dynamic characteristics are too important to be brushed over thus lightly here; we will discuss them more thoroughly later in relationship to amplifiers.

Meanwhile, note that the three main tube characteristics are related to each other, as would be expected. Multiply the transconductance (mhos) by the plate resistance to get the amplification factor, or:

$$g_m = \frac{\mu}{r_p}, \text{ to recast the equation.}$$

Thus, if we know two of these characteristics, we can always find the third one.

Each major tube manufacturer publishes a tube manual in which all of the above characteristics, as well as many other items of useful information, are given for the tubes he produces. Such a book is as important and necessary to the radio technician as a cookbook to a career-girl bride. You will realize why when future chapters refer to and *use* tube characteristics over and over again.

Chapter

13

The Power Supply

THE crystal set and its modern lineal descendant, the transistor receiver, are the only radio receivers that do not use vacuum tubes. All the rest—AM, FM, and TV sets—lavishly employ these so-called “electronic wonder-workers.”

By itself, though a vacuum tube is a cold and lifeless thing, about as full of magic as an empty pop bottle. Not until a filament current has warmed the cathode and given its electrons a stimulating hotfoot do they start swarming from the cathode surface; and only when the proper voltages have been applied to the tube’s electrodes can these darting electrons be pushed and pulled into precise behavior patterns that are able to delight our eyes with the sight of distant events and our ears with the sound of faraway music.

It follows, then, that all ordinary radio receivers must have some source of power that will heat the filaments of the tubes and also provide proper voltages for the electrodes. Batteries, the first answer to this need, are still used in portable receivers. A low-voltage, high-current A-battery is used to heat the filaments, connected either in series or in parallel. A higher-voltage, lower-current B-battery furnishes the electrode potentials. Quite often both of these batteries come in a single battery pack.

Battery power, while practical for sets used only intermittently, is expensive if called upon to supply a powerful, multitube console that is tuned in on a wake-up program the first thing in the morning, kept in a lather by soap operas all day long, and not turned off until after the last newscast at night. Radio engineers looking around for a cheaper source of power focused on the house-current socket. If they could make the electricity that came out of that socket do the job that the electricity from their batteries had been doing, they would be sitting pretty. The only catch was that batteries furnished d.c. whereas a.c. came from the light sockets.

That did not daunt our heroes. First they set out to solve the problem of how to use a.c. to heat the filaments. They could not use

this pulsing, reversing current to heat the slender filaments of their radio tubes because the filaments in those old-style tubes heated and cooled too quickly—so quickly, in fact, that the temperature, and consequently the emission, of these tubes rose and fell right in step with the reversing 60-cycle current. The result was a bad hum.

Two separate solutions were quickly found. First, increasing the bulk and current-carrying capacity of the filament allowed it to store sufficient heat so it could stay hot and continue to emit during the brief periods when the a.c. was falling to zero and reversing its direction. Second, heating the emitting cathode *indirectly* from a separate filament made the emission independent of rapid filament-current variations.

B-Supply Rectifiers

That took care of the A-supply, but getting rid of the B-battery was not so easy. The voltages applied to the plates and screens of the tubes had to be steady direct current. The manner in which the neat trick of converting a.c. into smooth-flowing d.c. is performed is really a two-part drama. Act One is called *Rectification*, and Act Two is titled *Filtering*.

Half-Wave Rectifier

Fig. 1301 shows one way of rectifying an alternating current. The

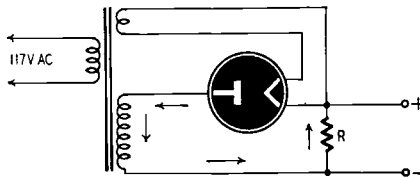

Fig. 1301—The basic half-wave rectifier.

transformer's primary is connected to the house current. The smaller of the two secondary windings develops the correct voltage for heating the heavy filament of the diode tube. The larger secondary develops an a.c. voltage slightly higher than the d.c. voltage required.

From our study of a.c. we know that, during one half of every cycle of voltage, the top end of the high-voltage secondary will be positive, and during the next half negative, with respect to the bottom end, which is connected through R to the filament. When the top end of the high-voltage secondary is positive, the plate of the rectifier is positive with respect to the filament. Under these conditions, electrons from the filament are attracted to the plate and flow down through the transformer winding and up through resistor R back to the filament, as shown by the arrows. When the top end of the high-voltage

secondary is negative, however, no current flows, the electrons being repelled by the negative charge on the plate.

The result of this check-valve action exerted by the rectifier tube is shown in Fig. 1302. Notice that the current flowing through resistor R of Fig. 1301 is in the form of pulses resembling half of a sine wave. Note, too, that these pulses are separated by the time interval required for the supply voltage to go through the negative half of its cycle. Since the system uses only half of the 60-cycle wave, it is a *half-wave rectifier*.

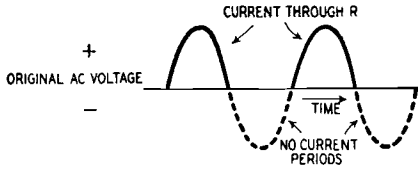

Fig. 1302—Half of the a.c. wave is used.

Efficiency-loving engineers, though, couldn't bear to see their rectifying system just sit there and twiddle its thumbs during half of every a.c. cycle; furthermore, smoothing out that pulse, wait-a-while, pulse, wait-a-while kind of d.c. took quite a bit of doing. Pressed by these annoyances, they worked out the *full-wave rectifier* shown in Fig. 1303.

Full-Wave Rectifier

Again we have a transformer with a secondary winding to heat the filament of our rectifier tube, but now our rectifier has *two* plates

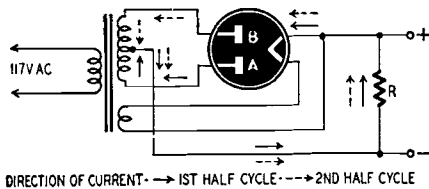

Fig. 1303—Duo-diode full-wave rectifier.

marked A and B. What is more, the high-voltage secondary has its ends connected to these two plates, while a wire brought out from the center of the winding now goes to R. Now the a.c. voltage across the ends of the transformer winding is slightly more than twice the d.c. voltage required.

Let us say that the voltage appearing across the entire high-voltage winding is 600 volts. Then, when the top end is 600 volts positive with respect to the bottom end, it is only 300 volts positive with re-

spect to the lead brought out from halfway down the winding. And when the bottom end is 600 volts positive with respect to the top end, that bottom end is 300 volts positive with respect to the centertap. That centertap is just like a man sitting in the middle of a seesaw: first one end of the board rises above him and then the other; there is always a downgrade to him from one of the two ends of the plank.

Recalling that the ends of the windings are connected to the plates of the tube and the centertap is connected through R to the filament, you can see that one plate or the other of the tube is always positive with respect to the filament. We know that under these conditions electrons move from the heated filament to whichever of the plates happens to be positive at the time, will flow down through one half of the winding to the centertap, and then will return through R to the filament. During the time a plate is negative, of course, it catches no electrons; thus each plate works only half of the time. But between

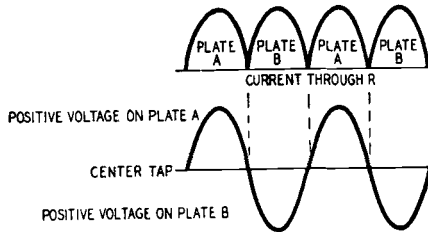

Fig. 1304—Tube plates conduct alternately.

the two of them, they keep current pulsing through R almost continuously. Fig. 1304 shows this clearly.

Smoothing Filters

The output of the full-wave rectifier is a decided improvement over that of the half-wave job, but it still looks too much like the bouncing gait of a frog for use on the plates of our tubes. We have to smooth out those peaks and valleys, and that is where our *filter* comes in.

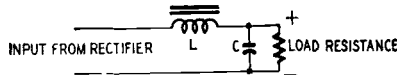

Fig. 1305—A choke-input smoothing filter.

Fig. 1305 shows a *choke-input filter* connected directly across the output of our rectifier. C is a capacitor of several microfarads and L is an iron-core filter choke of 10 to 30 henries. When the rectifier

tries to send its pulsing direct current through L, it runs head on into the choke's strong dislike for any *change* in the amount of current passing through it. We learned in our study of inductance that self-induction bucks any increase in current through a choke, while the collapsing field of the inductance will provide extra current in an attempt to prevent any faltering or reduction in the steady value. These efforts on the part of the choke to keep the current on an even keel result in lowering the peaks and filling in the valleys of the pulsing current delivered to the input of the filter from the rectifier.

Capacitor C stores up current during the small voltage peaks delivered to it from the choke and then returns this stored charge to the load when a dip in voltage starts to occur. This action still further smooths out the voltage across the load resistance. If additional filtering is wanted, another choke and capacitor can be added.

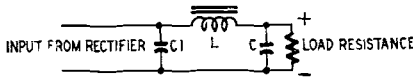

Fig. 1306—This filter has capacitor input.

Fig. 1306 is the diagram of a *capacitor-input filter*. The only difference is the addition of another capacitor C1, which charges to the peak voltage available from the rectifier. Between peaks this charge is partially lost by current flowing through the choke and the load resistance, but each peak restores the charge, as is shown by Fig. 1307.

The only time current flows from the rectifier is during the intervals when the rectifier output voltage is higher than the charge on C1. This means that current is taken from the rectifier during only a small portion of each cycle in the capacitor-input filter instead of flowing continuously as in the choke-input type. For a given amount of current drawn from the outputs of the filters, this means that the rectifier will have to deliver considerably heavier pulses of current to the filter of Fig. 1306 than it will to that of Fig. 1305, since the same amount of current has to be delivered in considerably less total time. That is why it is much easier to overload the rectifier tube with a capacitor-input filter than with a choke input.

Another difference between the two is in the d.c. voltage output. The output voltage of the choke-input filter is usually the *average* voltage of the rectifier output, while the output of the capacitor-input filter, especially with light loads, approximates the *peak* voltage of this output (minus the drop across the choke resistance). However, the output of the choke-input system falls off much more slowly under an increasing current load than will that of the capacitor-input filter. In general, though, the higher voltage available from a transformer with a capacitor-input filter makes this type by far the most popular

with radio manufacturers and also with hobbyists.

Power Supply Troubles

Power-supply troubles put lots of money into the pockets of radio technicians, and most of these troubles are quite easy to locate. For example, a rectifier tube that does not light because the filament is broken can usually be spotted at a glance; yet a radio containing such a tube will be as dead as a burnt match.

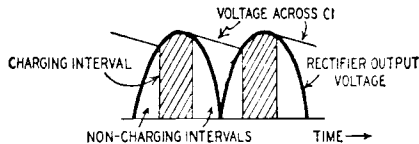

Fig. 1307—Rectifier delivers heavy pulses.

The eyes, too, are useful in deciding if there are any shorted filter capacitors. When a veteran technician first turns on a radio set, he watches the rectifier plates closely. If these plates show no color, he feels safe in leaving the set turned on while he makes other tests; but if the plates start to turn red, he quickly snaps off the receiver before damage is done to the rectifier tube or the transformer. In the latter case, he can feel fairly sure that one of the filter capacitors has shorted and provided a low-resistance return path for the electrons, allowing millions of them to bombard the plates and make them red hot from the impact very quickly.

On the other hand, if one of the capacitors opens up, the ears can easily detect the hum that appears in the speaker because of loss of the filtering action of the defective unit. The trained ear can even tell *which* of the two capacitors has opened because of the subtle difference in the type of hum produced.

Even the nose has its place in analyzing power supply troubles, for it can quickly detect the odor that clings to a transformer that has been overheated. This foul, pungent odor, beside which that of a skunk is pleasant by comparison, is impossible to describe adequately, but once smelled is impossible to forget or mistake for anything else.

However, I am not trying to say that you should depend entirely on your senses to locate power supply troubles. The point is that they are not hard to find, and those that cannot be seen, heard, felt, tasted, or smelled can be readily ferreted out with a volt-ohmmeter.

We are not through with the subject of power supplies. What we have studied this far are the fundamental types. Now we are ready to go ahead and investigate the a.c.-d.c. power supply, the auto radio type, the three-way portable power supply, the voltage-doubling rectifier, and so on. These and other interesting and practical variations will be taken up in the next chapter.

Chapter

14

Power Supply Types

THE last chapter discussed the common garden variety of power supply diagrammed in Fig. 1401. While this supply does an excellent job, there are at least three things wrong with it from the point of view of the radio manufacturer: it is heavy, it is bulky, and—most important of all—it costs too much.

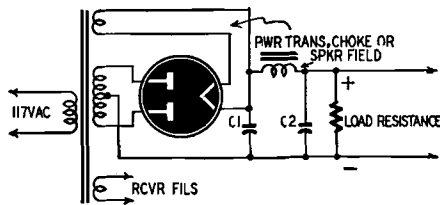

Fig. 1401—A basic full-wave power supply.

All three of these complaints point accusing fingers at the bulky, heavy, expensive transformer and iron-core choke. To get rid of these two items—especially the transformer—was a *must* for compact, light-weight, cheap receivers.

A.C.-D.C. Supply

Disposing of the choke was easy. As we shall learn in the next chapter, many speakers have *field coils* that consist of thousands of turns of wire wound on an iron core. Direct current must pass through this coil to make the speaker perform as it should. If we replace our filter choke with this field coil, such a current *will* pass through its turns; furthermore, the ready-to-hand inductance of the iron-core coil will perform exactly the same filtering job that the choke has been doing. Thus, by making the field coil do double duty, we can discard the filter choke.

Getting rid of the transformer, however, is like trying to put on *Uncle Tom's Cabin* without Simon Legree. It may be a villain, but it

plays important parts in both the A- and the B-supplies. Radical changes must be made in both of these before the transformer can be torn out by the roots and discarded.

Fig. 1402 shows the first step in accomplishing this. The filaments of all the tubes and a *ballast resistor* are connected directly across the 117-volt a.c. line. As can be seen, the voltage needed across the string of tube filaments is the sum of the individual tube requirements. The difference between this voltage and the line voltage is accounted for by the voltage drop across the ballast resistor.

In Fig. 1402, for example, are two tubes with 25-volt filaments and three using 6 volts on the filaments. That means that 68 volts is needed across the filament string. The ballast resistor, then, must be designed so there will be a 49-volt drop across it when the tubes are drawing their rated filament current.

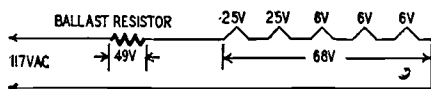

Fig. 1402—Transformerless heater string.

The tubes used in the first a.c.-d.c. sets had filaments that drew 0.3 ampere. When this current is multiplied by the 49-volt drop across the resistor, the resistor dissipates 14.7 watts in doing its voltage-dropping chore.

This amount of heat being constantly released within the close confines of a small cabinet did the capacitors and other parts no noticeable good; so the ballast resistor was fabricated as a separate, asbestos-sheathed resistance wire right into the line cord. This took the heat out of the cabinet, all right; but unfortunately the resistance wire did not take too kindly to the twisting, bending, and tying-into-knots that most line cords suffer.

Then the tube manufacturers came dashing to the rescue. They brought out sets of tubes whose total filament voltages were exactly equal to the line voltage; and, to reduce the heat dissipated by the tube filaments, they reduced the current requirements to 0.15 ampere. This got rid of the ballast resistor as well as the filament-heating portion of the transformer; and these tubes, with their various octal, loktal, or miniature bases, are the ones used in most a.c.-d.c. sets today.

There is only one flaw in the setup—it is hard on tubes. Any service technician knows that he will put three tubes into a transformerless receiver for every one he replaces in a set using a transformer. The fault is that the cold filament resistance is much less than the hot filament resistance. As a result, when the set is first turned on, a heavy surge of current passes through the filament wires. The strong magnetic fields that surround adjacent loops of the filament wire inside a cathode act upon each other, making the filament “wriggle” violently

under the influence of this heavy current; and often the movement either fractures the filament or causes it to short out to the cathode sleeve.

The only reason the transformer is easier on tubes is that the regulation of the voltage delivered by the filament secondary is much poorer than is that of the line. When there is a demand for heavy current, the transformer secondary voltage sags and so cannot deliver it; but the 117-volt line can and does put it out—much to the detriment of the tube filaments.

Just to show how radio engineering progresses in spirals, a new type of ballast resistor just introduced has a cold resistance several times its hot resistance. With such a resistor in series with the tube filaments, the initial current is quite low and rises slowly to the rated value as the filaments come up to their proper operating temperature.

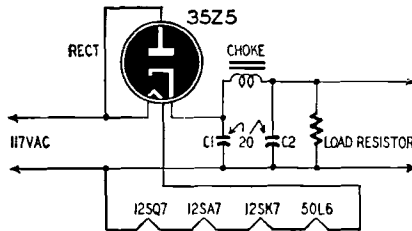

Fig. 1403—A typical a.c.-d.c. supply.

Since this arrangement is said to be even more gentle on filaments than a transformer, do not be surprised if we go back to ballast resistors.

But now let us look at Fig. 1403, which is the essential power supply circuit of an a.c.-d.c. receiver, and see how the B-voltage is secured. All of the tube filaments are hooked in series directly across the line. The plate of the half-wave rectifier tube is connected to the top side of the line. The cathode of this tube is connected through the filter choke and the load resistance to the other side of the 117-volt a.c. main. Outside of the fact that our rectifier has a cathode, this rectifier circuit is very similar to the half-wave transformer circuit described in Chapter 13. In that circuit, however, the electrons that flowed to the plate from the cathode (during the portion of the cycle when the former was positive) returned to the cathode by flowing around through the transformer secondary and the load resistance. In this circuit, there is no such apparent low-resistance return path from the plate to the "B-Minus" lead.

There is a return path, nevertheless, even though you do not see it. This path is through the windings of the generator producing the 117-volt a.c. The fact that this generator may be several miles away from the point where the receiver is operating means nothing to an electron that cruises at a rate of about 186,000 miles a second!

The filter circuit operates just as did those described in the previous chapter. The working voltage of the filter capacitors does not need to be so high, because the rectifier puts out only slightly more than 100 volts of filtered d.c. Capacitors of 150 working volts are normally used. Quite often the filter choke is replaced by a 1,000-2,000-ohm resistor. While such a resistor is cheaper, it is not so good at filtering as is the choke; thus it is necessary to increase the size of the capacitors to around 50 μ f each.

If this a.c.-d.c. radio were plugged into a 117-volt d.c. main with the positive side of the line connected to the plate, current would flow through the rectifier continuously instead of in pulses as it does on a.c. The d.c. would heat the filaments just as well as a.c., and our set would operate quite satisfactorily. A transformer set could not operate on such current, for the d.c. would quickly burn out the transformer primary.

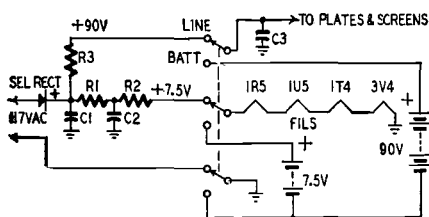

Fig. 1404—Supply for three-way portable.

That is why manufacturers call these transformerless sets “a.c.-d.c.” Of course, the possibility that the ordinary buyer will use the set on d.c. (except in a few large cities) is about equal to that of his winning the Irish sweepstakes, but it is much better sales psychology to talk about even the most useless “extra” your product may have than it is to mention what has been left out!

Three-Way Supply

The *three-way portable* does still better. It will work on 117 volts of either a.c. or d.c., or on self-contained batteries. Fig. 1404 shows the basic power supply of such a receiver. When the 3-gang switch is thrown to the battery position, the 7.5-volt A-battery heats the four filaments hooked in series, and the 90-volt B-battery supplies the plate and screen voltages.

When the switch is thrown the other way, the *selenium rectifier* permits the 117-volt a.c. across it to pass in only one direction. By chemical action, this compact little rectifier does the same job that a diode vacuum tube would perform—and does it without drawing filament current!

One branch of the rectified output flows through R1 and R2 and the filament string back to ground. The drop across the two resistors

is such that just the required 7.5 volts of d.c. appear at the ungrounded end of the filament string. C1 and C2 work in conjunction with the resistors to filter the voltage used on the slender, battery-saving, 50-ma filaments. This pure d.c. is necessary to prevent hum with such tubes, because they are very sensitive to filament-voltage changes (so sensitive, in fact, that most of these sets go dead on a.c. if the line voltage falls below 100!)

R3 and C3 provide further filtering for the other branch of the

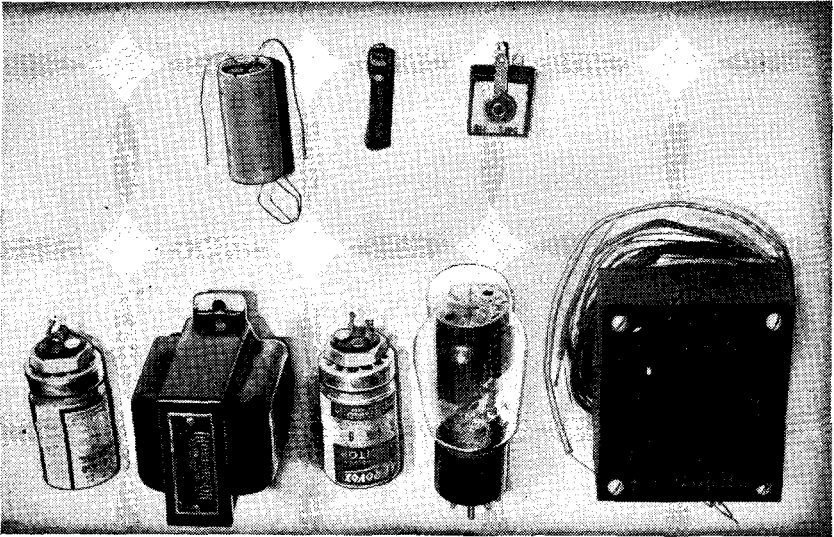

Fig. 1405—Parts for transformer-type B-supply are replaced by the a.c.-d.c. parts above.

rectifier's output that supplies the plates and screens of the tubes. The photograph, Fig. 1405, shows the difference in the amount of parts needed for a.c.-d.c. power supplies and transformer-type supplies. Note how few parts are used in the a.c.-d.c. supply (upper part of photo) compared with the transformer-type supply (lower part of photo).

Voltage-Doubler Supply

The transformerless power supplies so far discussed have outputs roughly equal to the line voltage, but it is possible to secure an output voltage twice the line voltage without using a step-up transformer. This is done by a gadget called a *voltage doubler*, one form of which is shown in Fig. 1406.

When the side of the line connected to the plate of the upper diode is positive, electrons attracted from the cathode leave C1 with a charge nearly equal to the line voltage. When this same side of the line

swings negative, current flow ceases in the upper diode; but as the cathode of the lower diode becomes more and more negative, electrons flow from it to the plate, and charge C2 to the line voltage. C1 and C2 are

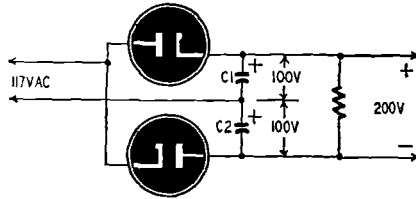

Fig. 1406—A full-wave doubler.

connected so their charges are in series and add together; therefore, twice the line voltage appears across the load resistance.

In practice, instead of separate tubes, a twin diode with individual cathodes is normally used. Probably voltage doublers would be more popular if it were not for the fact that the output voltage is very dependent upon the capacitance and condition of C1 and C2. Too, the output voltage falls off rapidly when the load current is increased.

Auto-Radio Supplies

The typical American cannot long enjoy doing anything unless he can do it in his car, so he began to demand an automobile radio. The first ones used the car battery to heat the filaments of the tubes and B-batteries to supply the other electrode voltages. But radio engineers began scheming to add the burden of the B-supply to the already long-suffering car battery. What was needed was some way to step up the battery's 6 volts of direct current in the same way a transformer steps up alternating voltage.

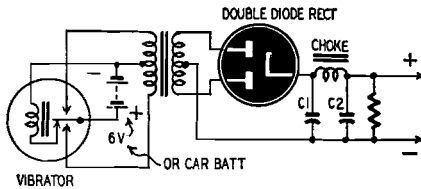

Fig. 1407—Non-synchronous power supply.

Then they remembered that pulsing d.c. in the primary of a transformer results in an expanding and contracting magnetic field that reacts upon the secondary winding in very nearly the same manner as does a.c. across the primary. They devised the circuit shown in Fig. 1407.

The vibrator is simply a buzzer mechanism that keeps the reed vibrating back and forth so that it touches first one contact then the

other. When the top is touched, current flows from the battery through the contact points then *down* through the top half of the transformer primary. When the lower one is touched, current flows through it then *on up* through the bottom half of the primary. The effect of these two regular, opposite-going pulses of current is practically equal to an a.c. voltage across the primary. Consequently, the voltage is stepped up, rectified, and filtered just as it would be if the transformer were operating on a.c. The steady d.c. from the battery has been changed to pulsating d.c., then converted and elevated to a much higher a.c. voltage, next rectified and so changed back to a pulsating d.c., and finally smoothed out by the filter so that it once more is pure d.c.!

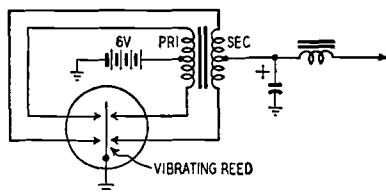

Fig. 1408—Synchronous vibrator power supply.

Fig. 1408 shows how a *synchronous vibrator* can be used to do away with even the rectifier. Two sets of contacts are employed to ground one end of the primary and one end of the secondary simultaneously. The grounding is done in such a sequence that the d.c. pulse in the primary produces a voltage in the secondary that makes the ungrounded end of this winding positive by a certain value. This means that the centertap of the secondary is positive by half of this value with respect to ground.

Then when the reed swings the other way and grounds the other ends of the primary and secondary, the end of the secondary that had been grounded becomes positive; but this change still leaves the centertap positive with respect to ground. The result is that every complete cycle of the reed causes two pulses of d.c. voltage to appear at the centertap with respect to ground. All that is required is to filter out this pulsating voltage and apply it to our plates and screens. No electronic or chemical rectifier is necessary in this circuit. Most vibrators operate at 115 cycles so filtering is simpler.

An interesting noncar use of the vibrator power supply is in the storage-battery three-way portable receiver. This set uses a small 2-volt storage battery and a synchronous vibrator for power. The battery is kept charged by a trickle charger operated from the 117-volt line. The set actually operates from the battery at all times; but if the line cord is kept plugged in, the input from the charger to the battery just about equals the output used to power the portable receiver.

Chapter

15

Sound and Loudspeakers

"The music goes 'round and 'round
And it comes out here!"

NEVER do I hear the words of that song of a few years back without grinning and thinking they might well be a beautifully brief description of the whole complicated business of radio.

Certainly the music *does* go 'round and 'round from the moment it enters the microphone of the broadcast studio and is transformed into a weak audio-frequency current.

By the time the signal reaches the receiving antenna, it is so enfeebled by its journey that once more it must be nursed back to health before it is ready for the operation of being separated from the carrier. R.F. Amplification, Conversion, and I.F. Amplification have charge of this building-up process; and Doctor Detection performs the operation. After that, the audio signal must still be passed through the audio amplifier of the receiver before it "comes out here."

The "here" that actually releases the captive sound from the magic spell of electricity is the *loudspeaker*. It might be called a microphone in reverse, for, just as a microphone is a device for changing sound waves into electrical currents, a speaker is a device for changing electrical currents back into sound waves. The speaker is at the very end of the whole process of radio reception, in which it has the very last word. So it stands to reason that it is a most important piece of apparatus. Unless it does its job well, the good work of all the other units goes for nothing.

Brief Review of Sound

Since a loudspeaker is a sound device, let's review briefly some of the properties of sound before examining loudspeaker operation:

Sound is "the sensation produced by a stimulation of the auditory nerves by vibrational energy." Suppose we strike the tuning fork of Fig. 1501 and start it vibrating. As a prong of the fork moves back and forth, it alternately causes the molecules of air next to it to be pushed together and to be spread apart. These *compressions* and *rare-*

factions travel through the molecules of air. To understand *how*, imagine that we have several croquet balls lined up in a shallow trough and separated by equal lengths of large-diameter coil spring. If we strike a ball at one end of the trough, it will compress the spring between it and the next ball. That ball will pass this shove along to the next, while the first ball is being thrust backward by the first compressed spring. In this manner the motion originally given to the first ball will travel through the whole string, causing each ball first to move closer to its neighbor and then to spring away from it.

In exactly the same way, the thrusts that the tuning fork gives to the surrounding air is transmitted to the ear, and these tiny variations in pressure cause the eardrum to move back and forth in step with the tuning fork. In that instant, vibration becomes sound.

A compression and an accompanying rarefaction make up a *sound wave*. If we could see these waves moving from the fork to the ear, we would notice that, when the fork vibrates slowly, only a few waves pass in front of us in a given space of time; so we might say that the *frequency* or *pitch* of the sound is low. Moreover, we would notice

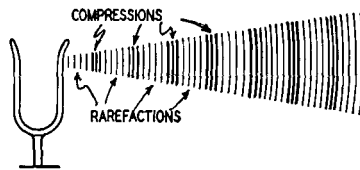

Fig. 1501—Vibrating fork sets up waves.

that the distance between two adjacent compressions is quite great, or that the sound wave is *long*.

On the other hand, when the fork vibrates rapidly, the number of waves passing before us is greatly increased. We say that the sound now has a higher frequency or pitch. At the same time, the wavelength would be noticeably shorter.

When the fork vibrates violently, it gives much stronger shoves to the air molecules than it does when moving through a small arc. The varying amount of energy thus imparted to and contained in the sound waves is referred to as the *intensity* or *amplitude* of the sound. The ear recognizes this difference in intensity as a variation in the *loudness*.

The current that is delivered to the speaker is an *electrical* reproduction of the *physical* sound that fathers it. This current is alternating in nature, but the frequency is not monotonously fixed as it is in the 60-cycle light mains. Instead, it is free to vary from instant to instant so that the electrical cycles per second are exactly equal to the number of sound waves per second striking the microphone. At the same time the power of the alternating current goes up and down in accordance

with the intensity of the sound waves. A weak 1,000-cycle tone will produce a weak 1,000-cycle alternating current at the output of our receiver; but a loud 5,000-cycle sound will produce a powerful 5,000-cycle current at the same place.

The Dynamic Speaker

Now we are ready to see how a loudspeaker changes this alternating current back into sound. Take a look at Fig. 1502, a drawing which illustrates the elements of a loudspeaker mechanism.

The *field coil* consists of thousands of turns of wire wound in many layers in a doughnut form that fits snugly around the cylindrical soft-iron *pole piece*. This pole piece is firmly fastened to the rear of the heavy, soft-iron *frame* and projects through the exact center of a hole in the front of this frame, leaving a small space between the pole piece and sides of the hole. A tube of paper with a coil of wire wound in

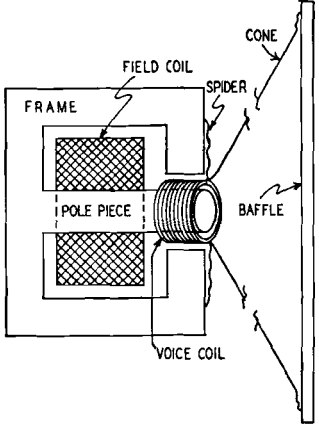

Fig. 1502—Cross section of a loudspeaker.

two or four layers around it is slipped over the pole piece and rests in this space. This is the *voice coil*. It must not touch either the pole piece or the frame; therefore, a flexible brace, called the *spider*, holds the voice coil centered in the narrow space, allowing it to move freely backward and forward on the pole piece. A paper *cone* is cemented to the voice coil, and the outer edge of this cone is also flexibly supported so that it may move back and forth with the voice coil.

Suppose we pass a direct current through the field coil. From our study of magnetism we know that this will magnetize the pole piece. The lines of force of its field will flow out the front end of the pole piece cross the gap between it and the frame and then return to the rear of the pole piece through the soft-iron frame. There will be a very

concentrated steady magnetic field in the small air gap in which the voice coil rests.

Suppose we pass another current through the turns of the voice coil. This current will produce a magnetic field of its own, and we shall have two different sets of magnetic lines of force. The interaction between these two magnetic fields will cause the voice coil to move back or forth on the pole piece. The direction of movement will depend upon the direction of current flow through the voice coil, and the amount of movement will depend upon the strength of the current.

Stopping right here, can't you guess what will happen when we connect the output of our radio receiver to the voice coil? Remember this output is an alternating current whose frequency varies with the pitch of the sound producing it and whose power reflects the loudness of the original sound. Since the direction of movement of the voice coil depends upon the direction of current through it, an alternating current will cause it to move back and forth, exactly in step with the frequency of the varying current through the coil. Here we have a *vibrating* object that can produce sound! A stronger current will cause the coil to have a greater movement than a weak current; thus a *violent* swing of the tuning fork will produce a *loud* sound that will result in a *strong* current that will cause a *violent* movement of the voice coil and cone and produce a *loud* sound.

The whole thing sounds rather like a dog chasing his tail, but it establishes the point that the sound from the speaker is almost exactly the same as that in the broadcast studio—and that is our goal.

A comparatively recent tendency in this *field-coil dynamic* type of speaker has been to get rid of the field coil. This coil was needed only to create a strong magnetic field in the space in which the voice coil works. (However, radio engineers made a virtue of a necessity and also used the field coil for a filter choke.) In the last few years we have learned how to make powerful, compact, permanent magnets many times stronger than formerly believed possible. When a permanent magnet is used to replace a section of the pole piece, the speaker works just as it did with the field coil; but a great saving has been made in cost and weight, and we no longer need a source of field-coil current. Such speakers are called "permanent-magnet dynamic speakers" or, less formally, "PM speakers."

The human ear cannot hear vibrations of all frequencies. Any frequency between 15 and 20,000 cycles is called an audio frequency, but the range of hearing of most people is probably between 30 and 16,000 cycles per second. What is more, the response of the ear is similar to the spelling of Ohio: "round on the ends and high in the middle," as is shown in Fig. 1503. Sounds of equal actual intensity seem much louder in the range between 500 and 3,000 cycles than when pitched either above or below this range.

Low-Note Difficulties

If the ear is to hear low-pitched tones at all, the speaker must move a considerable mass of air to produce the necessary changes in pressure with the comparatively slow-motion movement of the voice coil. That is why the cone is attached to the coil. It acts like a piston and allows the voice coil to set a large quantity of air into motion.

Even this advantage is largely lost at low frequencies without the use of a baffle. As the cone moves forward, it compresses the air in front of it and lessens the pressure behind it. At low frequencies, this cone movement is comparatively slow, and the pressure being built up in front simply slides over the edge of the cone and reduces the partial vacuum we are trying to create behind. It is like trying to use a 3-inch piston in a 4-inch cylinder: most of the pressure simply escapes past the sides of the piston, and the net result is very little change in pressure front or back.

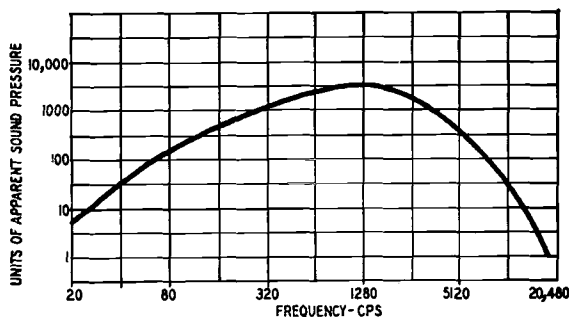

Fig. 1503—Apparent sound pressure curve.

The remedy is to lengthen the path the pressure or sound wave must travel in going from in front of the cone to the back so that by the time it gets there all ready to do its dirty work, the cone has started back and the arriving pressure wave actually contributes to the pressure the backward-moving cone is starting to build up behind the speaker. The name *baffle* is given to the means used to lengthen this path.

While a large cone and voice coil help reproduce the low frequencies, the increased mass of these items seriously interferes with the reproduction of high frequencies. If you have trouble in understanding *why*, just reflect on how much easier it is to flutter a handkerchief than a bed quilt! By making the cone out of flexible material we can help the situation, for then the whole cone will move back and forth at the low frequencies while just the inner portion will follow the rapid vibrations necessary for high-frequency reproduction.

The best solution is the use of two speakers: a small "tweeter" especially designed for the highs, and a large "woofer" that is intended to reproduce the low frequencies. Both of these speakers are often contained in a single unit. A device known as a crossover network separates the frequencies below the crossover frequency—usually somewhere between 400 and 2,000 cycles—from those above it and feeds each set of frequencies to the speaker which is best able to reproduce them.

Repair Problems

Most of the troubles which appear to originate in the speaker of a receiver are actually in the output transformer usually attached to the speaker. A burned-out primary is responsible in nine out of ten cases, and can easily be detected by checking with an ohmmeter. A red-hot screen in the output tube is another indication of an open plate lead and points unerringly to the burned-out transformer primary.

Real speaker troubles consist of shorted or open voice and field coils, of voice coils that are not properly centered and so rub on the pole piece or frame, of breaks in the flexible leads that connect the output transformer to the voice coil, and of cracked, worn, and warped speaker cones. Good speakers have provisions for recentering the voice coil by shifting the spider. The best repairs for the other faults mentioned is simply to replace the defective parts. Small faults in the cone can be repaired with speaker cement; but extensive use of this expedient will result in a cone that is not uniformly flexible and cannot perform as intended. A new cone is a much better repair.

All in all, speakers that have not been excessively abused give very little trouble and in no way deserve the suspicion that radio owners always direct at them when their sets go dead.

The Power Output Stage

THAT hallowed phrase from the world of baseball . . . Tinker to Evers to Chance . . . is a classic description of split-second, three-way co-operation. In a radio receiver, though, we have another example of one-two-three team play that might well be paraphrased: “output stage to transformer to speaker.” Let us examine this trio, starting with that familiar member, the speaker.

Voice-Coil Impedance

In the last chapter we learned that to make a speaker “work,” we must have a varying current flowing through the voice coil. This voice coil cannot contain many turns of wire for two good reasons: first, there simply is not room for a large coil in the restricted space in which the voice coil moves, and this space cannot be increased without weakening the strong magnetic field needed in the air gap.

Second, more turns of wire would increase the inductance, and inductance is something we do *not* need in a voice coil. The reason is that inductive reactance—unlike pure resistance—plays favorites with frequencies, and it has low-down tastes. It will allow a low frequency to pass with comparatively little hindrance, but its opposition grows stronger and stronger as the frequency becomes higher and higher. Such partiality would mean that a speaker with a highly inductive voice coil would unduly accent some audio frequencies and play down others. The sounds coming from such a speaker would not be a true reproduction of the sound originally heard in the broadcasting studio.

Voice-coil inductances are like whiskers: we cannot get rid of them entirely, but we can keep them whittled down. The way to keep inductance small is simply to keep the number of turns low. Unfortunately this solution, like the solution of nearly every other problem in this wacky radio business, gives birth to a new problem. The strength of the magnetic field produced by currents in the voice coil depends on two things—the number of turns in the coil and the strength of the

current. If we are going to have few turns, we are going to have to have lots of current. Heavy current means large wire. Large wire means low resistance—and that is what our voice coil has. You will soon see why this low resistance complicates coupling a speaker to the radio receiver.

Usually the d.c. resistance of a dynamic speaker voice coil lies somewhere between 1 and 20 ohms, the average being in the neighborhood of 5 ohms. The impedance of the coil—resistance plus inductive reactance—is roughly 25% higher than the pure resistance. For example, a voice coil that has 4 ohms of resistance will present approximately a 5-ohm impedance to a frequency of 400 cycles per second, this being the frequency at which voice coil impedances are usually measured. This is good, for the impedance of our coil consists chiefly of resistance and will present a fairly uniform impedance to all audio frequencies.

The Output Stage

Now let us go to the other end of this triple-play combination and consider the *output stage* of the receiver. By “stage” we mean a tube or combination of tubes, together with proper input and output circuits, that performs a single operation on the signal passing through the receiver. The output stage is the one that handles the signal just before it is delivered to the speaker. The essential parts of an output stage, are shown in Fig. 1601. For the purpose of our study, we shall assume that our output stage consists of a single triode tube connected as shown in Fig. 1602.

An alternating, audio-frequency voltage is delivered through capacitor C from the preceding stage to the grid of our output tube and appears across resistor R. This means that the alternating voltage is really in series with the fixed negative voltage that the bias battery delivers to the grid. Voltages in series can be added like positive and negative numbers in algebra. That means that when the audio voltage is on the negative half of the cycle, its value is added to the bias voltage and makes the grid more negative. During the positive half of the cycle, its value is subtracted from the negative bias voltage and the grid becomes less negative.

Fig. 1603 shows what happens to the plate current while the grid voltage is waltzing around in this dizzy fashion. As might be predicted from our study of triode action, the plate current rises and falls right in step as the voltage on the grid becomes less and more negative. As is evident from Fig. 1603, the pattern of the plate current is a reproduction of the audio voltage applied to the grid.

“Eureka!” you are probably shouting in your best Greek accent. “Here we have exactly what we need to make our speaker do its stuff: a varying current that follows curves better than a lastex bathing suit! All we have to do now is to place our voice coil in the plate lead of the

output tube and sit back and listen to the program rolling in loud and clear.”

Not so fast, my friend! You are forgetting something—or several somethings. Remember we said few turns on the voice coil meant heavier currents—or rather excursions of current, for it is variation in current that makes our voice coil move back and forth. Well, the plate current swings of our triode are not likely to exceed 100 milliamperes, and that is far too small a current to get much action out of our speaker.

And there is another point. You will recall that when we talked about characteristics of vacuum tubes we found that every tube has a

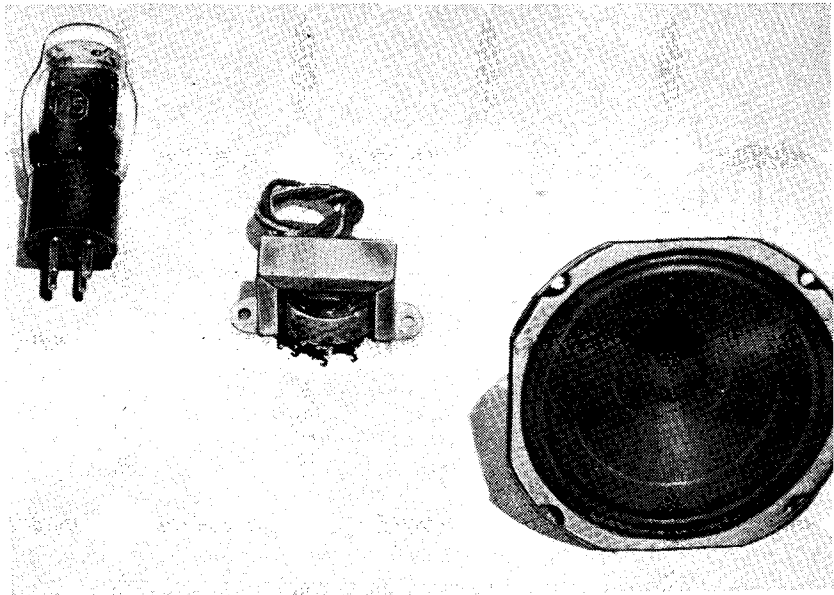

Fig. 1601—Three essentials of the output stage are tube, transformer and loudspeaker.

plate resistance. If we consider our output tube a generator of power—and it really is—this plate resistance represents the internal resistance of our generator. It is an easily demonstrated fact that a maximum transfer of energy takes place between a generator of power and the thing receiving the power when the impedance of the “giver” exactly matches that of the “givee.” (I’m haunted by the feeling that there is some sort of analogy in there to a playboy trying to give a mink coat to a chorus girl, but I can’t quite pin it down.)

To demonstrate this “easily demonstrated fact,” suppose we consider Fig. 1604. Here we have a 100-volt generator with an internal resistance R_i of 10 ohms and a variable external resistance R_e that is

used as the load. Table 16-1 shows what happens to the current, the voltage drop across R_e , and the power dissipated by R_e as its resistance is set at various values. It is readily seen that the *maximum power* is delivered to the load when its resistance is 10 ohms, the same as the internal resistance of the generator. Either increasing or decreasing this load resistance results in a loss of power. You might also note, for future reference, that the *maximum voltage* across the load resistance does *not* appear at this point but goes up as the load resistance increases.

Table 16-1—Conditions for Maximum Transfer of Power

I	II	III	IV
R_e (Ohms)	Current (Amperes)	Voltage across R_e	Power in Watts $II \times III$
1	9.09	9.09	82.6
5	6.66	33.3	222.0
10	5	50.0	250.0
40	2	80.0	160.0
100	0.909	90.9	82.6

This is easy to see if you will consider that when R_e is made smaller, the output voltage gets smaller, until R_e gets to zero and there is no output voltage. With no output voltage there can't be any power because the power is equal to voltage \times current.

Going the other way, if R_e is made larger, the current keeps getting smaller until there isn't enough current to have any output power.

If a power tube is a 6B4-G with 250 volts on the plate, its plate resistance is 800 ohms; and it will deliver the most power to a load in its plate circuit if the impedance of this load is also 800 ohm. But, when a tube is thus putting out its maximum amount of power, the plate current variations do not exactly follow the grid voltage current changes, and we have some *distortion of the signal*. (More about this distortion subject in the next chapter.)

This distortion can be reduced by increasing the load resistance to something more than twice the plate resistance. This means a reduction from the maximum power output of our tube, but the loss is so small the ear cannot detect it. For obtaining maximum "undistorted power output" from our 6B4-G tube, the manufacturer recommends a load resistance of 2,500 ohms.

And now we see why the low resistance of our voice coil presents a problem. There is a lot of difference between the 2,500 ohms needed in series with our output tube's plate lead and the 5 ohms or so of impedance in our voice coil. If we placed the voice coil in the plate lead, practically no power would be delivered to the speaker. What

we need is some dingus that will allow us to “match” the high plate resistance of the output tube to the low voice-coil impedance of the speaker in the same way that a plumber used a reducing coupling when he wants to connect a large pipe and a small one together.

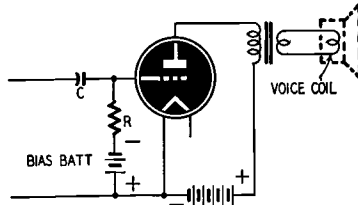

Fig. 1602—A single triode output stage.

Output Transformer

In discussing the transformer we said it provided a method of changing high voltage at low current into low voltage at high current. Suppose we place a transformer between the output tube and the speaker as is shown in Fig. 1602. Let the primary winding placed in series with the plate lead consist of many turns of fine wire, while the secondary connecting across the voice coil is made up of a few turns of heavy wire.

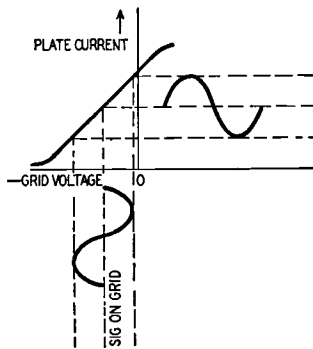

Fig. 1603—Output varies with grid signal.

A review of the transformer action story will help us understand exactly what takes place when an audio signal appears on the grid of the output tube. First, this causes the plate current to rise and fall. The surging of this varying current through the primary of the transformer sets up an expanding and contracting magnetic field that, in turn, produces an alternating current in the secondary winding. The

flow of this current through the voice coil makes the cone move back and forth and produce sound from the loudspeaker.

Because of the high inductance of the primary, a considerable voltage appears across this winding. Since our transformer is of the "step down" type, much less voltage appears across the secondary, but the current in the secondary is accordingly much heavier than the primary.

As explained before, when a low resistance is placed across the secondary of a transformer, the heavy current that this causes to flow in that winding produces a magnetic field that weakens the back-electromotive-force or impedance of the primary. If we increase the value of this load resistance and so reduce the current in the secondary, more "bucking voltage" is available to the primary and its impedance to the flow of a variable current rises. It follows then that we make the primary impedance anything we wish simply by varying the load across the secondary. The whole thing works like a pair of long-bladed scissors in which a $\frac{1}{4}$ -inch opening of the handles results in a couple of inches of separation of the points.

Just as the amount of control that the handles have over the blades of the shears depends upon the ratio of the lengths of these two elements, so does the effect of secondary load upon the primary impedance of our output transformer depend upon the ratio between the number of turns of wire on each of these two windings. This relationship has been neatly expressed in one of those formulas so dear to the heart of the engineer:

$$N = \sqrt{\frac{Z_s}{Z_p}}$$

In this formula N is the turns ratio, secondary to primary; Z_s is the impedance of the load connected to the secondary; and Z_p is the impedance presented by the primary. Let's see if we can use this simple-looking critter to figure out the turns ratio needed:

Z_s is 5 ohms; Z_p is 2,500 ohms; so N must equal $\sqrt{\frac{5}{2,500}}$ or $\sqrt{\frac{1}{500}} = \frac{1}{22}$. That means that our turns ratio will be just about $1/22$. If our primary contains 220 turns, our secondary should have 10 turns.

The Universal Output Transformer

In practical radio servicing it would be most inconvenient to have to obtain an exact duplicate unit for each output transformer replacement job, and it isn't necessary. "Universal" output transformers, of the type diagrammed in Fig. 1605 are provided for this purpose. A tapped secondary allows you to have any turns ratio needed. Either the primary or the secondary *could* be tapped to secure the proper

turns ratios needed for matching various output tubes to a wide variety of voice coils, but it is easier to tap the secondary.

You do not have to use your adding machine, slide rule, or abacus to figure out just which taps to use for matching a certain tube to a certain voice coil. A chart furnished with the transformer tells exactly what taps are needed to do any job you may encounter. For example, one such chart shows that if a particular tube is connected across the primary, a 1-ohm voice coil should be connected across taps 5-6 of the secondary; a 6-ohm coil across taps 1-5; a 12-ohm coil across taps 1-6, etc.

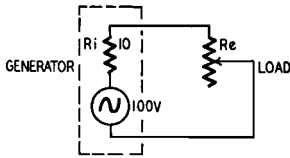

Fig. 1604—Output varies as the load is changed.

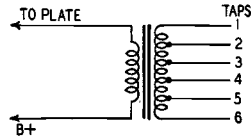

Fig. 1605—Taps allow variety of matching.

If the proper match is not made, the quality of reproduction will suffer, although the average ear may not notice the distortion until the mismatch is quite serious. In general, the distortion will be worse if the tube is forced to work into a load that is below its plate resistance than if it works into a load that is higher than the recommended value. Usually the low frequencies are accented if the output tube is made to work into a too-high impedance, while the high frequencies are pushed up when the output impedance is too low.

Many output stages consist of two tubes working in a *push-pull* circuit, but this will be taken up in the next chapter in which we really delve into the *Care, Feeding, and Love-Life of the Audio Amplifier*.

Chapter

17

The Voltage Amplifier

IN our crablike method of progressing backward through a radio receiver, we always assume that each stage will receive just the right kind of a signal from the stage before it. When we discussed power amplifiers we found that we needed an audio-frequency signal on the grid of that amplifier to make it work.

This audio voltage must be pretty husky if the output tube is to be worked at full power. A little reflection shows why this is so: a power output tube must have a relatively heavy plate current to develop much power (power is always the product of *voltage and current*) in its plate circuit. This means that the plate resistance of the tube must be low. The way to lower the plate resistance of a triode is to move the plate closer to the filament, thus reducing the amplification factor of the triode. A low amplification factor makes it necessary to have large swings of grid voltage to produce large swings of plate current.

In a triode power amplifier, the peak-to-peak voltage required on the grid for full power output may be as high as 70 to 80. Screen grid and beam tubes can deliver high power outputs with much lower grid voltage swings, but even they require high audio voltages (from 2 to 20 volts approximately) on their grids.

But the audio voltage that results when the audio portion is peeled off the carrier by the detector is often only a small fraction of a volt. Before this puny voltage can swing the grid of our power amplifier back and forth as it should be swung, it must be given a shot of spinach juice or something that will make it many times more powerful.

The "builder-upper" that does this trick is called an *audio-frequency amplifier* or simply an *audio amplifier*. Its job is to take the little audio voltage delivered to it by the detector and consisting of frequencies from 50 to 15,000 cycles per second and amplify this voltage many times, being careful to play no favorites and to boost all of the frequencies exactly in proportion to the amplitude they had before the boosting operation started. If all of the frequencies are not uniformly boosted, we have what is called *distortion*. The voice or music that

comes out of the amplifier no longer sounds like what went into it. The result is about the same aurally as the visual experience of peering into one of those magnifying shaving mirrors: there is plenty of enlargement, but the perceived result does not bear much resemblance to the original! If necessary, two or more stages of audio amplification can be used between the detector and the power amplifier; but this is usually not necessary, at least in small receivers; a single pentode can amplify a signal 150 times or more.

Audio Voltage Amplifier

Fig. 1701 shows the basic circuit of an audio amplifier stage. A triode is used for simplicity. This should look familiar to you for it is

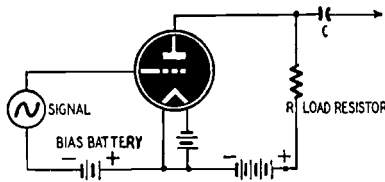

Fig. 1701—Basic audio amplifier circuit.

nearly the same circuit as that of the power amplifier studied in the last chapter. The only difference is that we have a resistor in the plate lead instead of an output transformer primary.

A power amplifier and a voltage amplifier are really first cousins. The big difference lies in what we want them to deliver. In Chapter 16 we wanted *power* (volts \times amperes) to drive our speakers; so we selected a tube with a husky plate current and adjusted our plate load impedance for very nearly maximum power output. You will recall that this load was raised from the one that would give the most power output (equal to the plate resistance) to more than twice this figure in order to reduce distortion.

No power is used in the grid circuit of the power amplifier because no current flows in this circuit. Only voltage is needed; therefore, all our audio amplifier stage need do is amplify voltage. With that in mind, we select a tube with a high amplification factor, such as a pentode or a high-mu triode, and we use a plate-loading resistor with a value several times the plate resistance of the tube. Fig. 1702 shows how the actual amplification of the tube approaches its amplification factor as the plate load resistance is increased.

Remember the discussion of the dynamic characteristics of vacuum tubes? These dynamic characteristics revealed exactly how the plate current varied in accordance with the grid voltage when various values of plate resistance were used. Fig. 1703 shows a whole family of

dynamic-characteristic curves for a triode. Each curve represents a different value of plate load resistance.

Fig. 1704 is a close-up study of what happens when we select one of these curves, the one with the 50,000-ohm plate resistor, and apply an audio voltage that swings 2 volts either side of zero center to the grid. This audio voltage is applied in series with -5 volts of bias on the grid.

Notice that if you read along the left side, of the graph, the vertical divisions represent plate current in milliamperes; while if you read along the right side, they stand for the actual voltage on the plate after the voltage drop across R has been subtracted from the 300-volt plate supply.

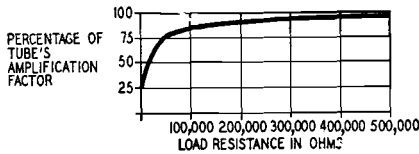

Fig. 1702—Voltage amplification versus load resistance.

Before the audio signal is applied to the grid, our -5 volts of bias causes the tube to draw 2 milliamperes of plate current. The drop through R ($.002 \times 50,000$) is 100 volts, leaving 200 volts on the plate. When the audio grid swings to its maximum negative value of 2 volts, the total grid voltage is $-5 + -2$, or -7 volts. At this point our plate current falls to about $1\frac{1}{3}$ milliamperes, the drop across R ($.0013 \times 50,000$) is only about 65 volts, and the voltage on the plate rises to 235 volts.

On the other hand, when the audio voltage swings to its most positive value, the total grid voltage becomes $-5 + +2$, or -3 volts; and the plate current rises to the vicinity of $2\frac{2}{3}$ milliamperes. This makes the voltage drop across R ($.00266 \times 50,000$) approximately 135, and the plate voltage falls to 165.

Phase Inversion

Keep in mind that for every value of grid voltage lying between these extremes there is a corresponding different plate current value and consequently a different plate voltage value. Any movement of the grid voltage in a positive direction immediately produces a proportionate increase in the voltage drop across R and an accompanying decrease in actual voltage on the plate of the tube. By the same token an increase of the grid voltage in the negative direction produces an increase in the positive plate voltage on the plate for the reasons just mentioned. Since a negative-going grid voltage results in a positive-going plate voltage, we say the grid and plate voltages are 180 degrees out of phase.

If we concern ourselves only with the voltage actually appearing across R—and we can separate this varying voltage from the d.c. voltage by leading it off with a capacitor C—we find that we have a king-

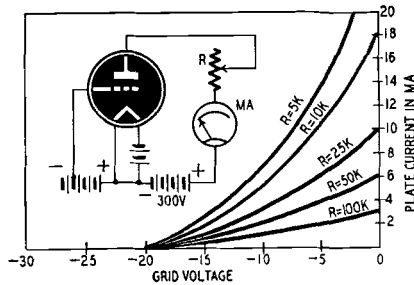

Fig. 1703—Triode dynamic characteristics.

size replica of the voltage on the grid of our audio amplifier. In the example we have been studying we know that our actual plate voltage varied from 165 to 235, or a total range of 70. Since this was produced by a peak-to-peak grid voltage of 4, we can see that our amplifier has amplified the grid voltage about $17\frac{1}{2}$ times.

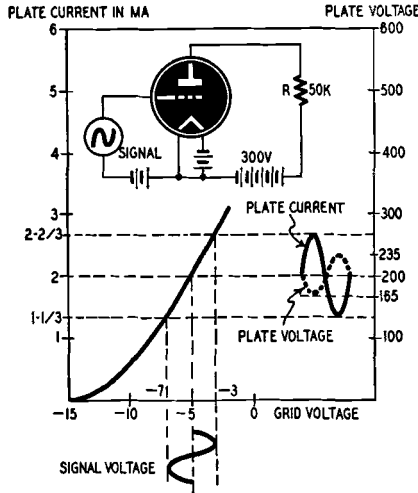

Fig. 1704—The grid signal varies both plate current and voltage.

Yes, a radioman has to be as familiar with curves as a beauty contest judge. Not only must he know which curve to select but he must also know what portion of that curve to use. Fig. 1705 shows what

happens if the fixed bias is set so that the curved instead of the straight portion of the "curve" is used. No longer is the plate current pattern a faithful reproduction of the audio voltage presented to the grid. It is non-symmetrical or lopsided. Under such conditions the audio signals being amplified by the tube are certain to be distorted and will not sound true to the ear.

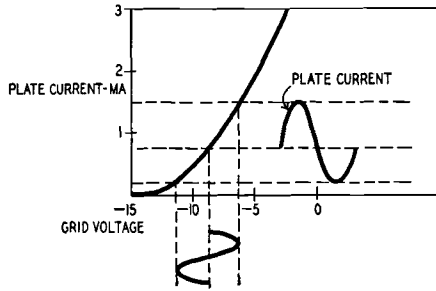

Fig. 1705—Incorrect biasing causes distorted output.

In the same way too large a signal on the grid of the tube will result in distortion as shown by Fig. 1706. If the audio signal is too great, the extremes of its swing cannot be kept on the straight portion

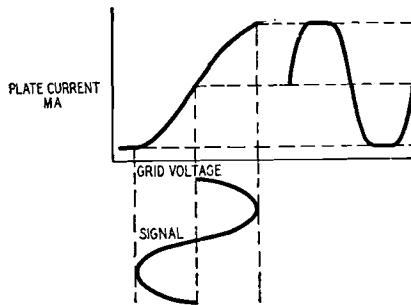

Fig. 1706—Too large a signal on the grid distorts the output signal.

of the curve, even though the bias is correctly set for the middle of this straight part. In this case the tips of the sine wave are flattened by this "overloading" of the audio amplifier.

Push-Pull Amplifier

By using two tubes in a push-pull circuit such as the one shown in Fig. 1707, we can have an exciting voltage for our amplifier that is twice that of a single tube. In this circuit the audio voltage is delivered to the grids by means of the input transformer. When one end of the

secondary of T1 is positive, the opposite end is negative; so only half of this total audio grid voltage can appear between the negative terminal of the bias battery and either grid. In the same way, while the plate current of one tube is rising that of the other tube is falling. Because of the way they pass through the two halves of the primary of

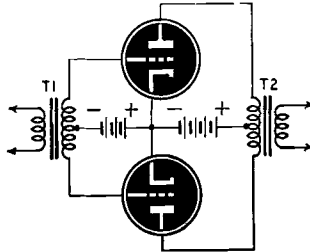

Fig. 1707—Diagram of a push-pull amplifier.

T2, these opposite-going currents produce voltages in the transformer that are in the *same* direction and so add together. This means that a push-pull stage has twice the power output of a single stage. As a matter of fact, it has more than twice the power output because a push-

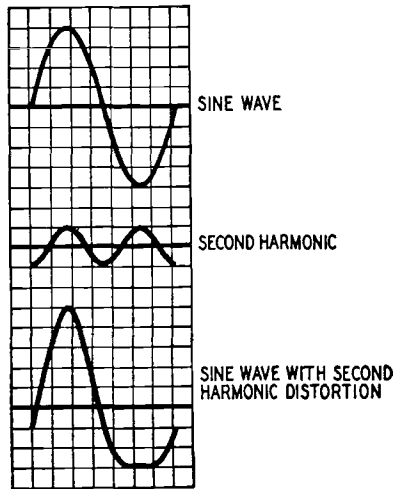

Fig. 1708—Second-harmonic distortion.

pull amplifier has less distortion and so can be made to put out increased power without exceeding the usual 5% permissible distortion figure.

Harmonic Distortion

To understand *why* a push-pull stage has less distortion, you must realize that an audio signal is like a pretty girl: it is seldom seen by itself. Accompanying it are other lesser audio voltages called *harmonics*. A harmonic is an audio voltage that is some multiple of the fundamental audio frequency. For example, if our fundamental frequency is 400 cycles, the second harmonic is 800 cycles; the third, 1,200; the fourth, 1,600, etc. Unfortunately the voltages of these harmonics combine with the voltage of the fundamental and produce changes in the waveshape of that fundamental that spell distortion. Fig. 1708 shows how the presence of a second-harmonic voltage wave can foul up a nicely shaped fundamental wave.

In a push-pull amplifier, the even-numbered harmonics are made to cancel their distorting effects on a signal passing through a single tube by combining the output of both tubes in the transformer in the plate circuit. Fig. 1709 shows exactly how this takes place. At A the

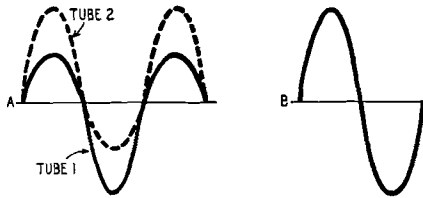

Fig. 1709—Push-pull amplifier cancels even harmonics.

solid line shows the harmonic-distorted wave produced by tube No. 1 of the push-pull stage. The dotted line portrays the similarly distorted output of tube No. 2, but notice that here the higher peaks appear on the opposite side of the line than they did for tube No. 1. At B is shown the amplified distortion-free wave that results from the combination of these two waves.

Incidentally, this same cancellation process also takes out any power supply hum that may be impressed directly on the plates of the push-pull output tubes; it does not, however, remove any hum that may be introduced into the amplifier from preceding stages. Neither does a push-pull amplifier reduce the distortion produced by odd-numbered harmonics, such as the third, fifth, seventh, etc.; but since the amplitude of the harmonic usually diminishes as its frequency departs farther from that of the fundamental, getting rid of the second harmonic is very much worth while.

Let us summarize what we have said about audio voltage amplifiers in this chapter. The job of this part of the radio receiver is to build up the small signal that is put out by the detector so it will be

big enough to drive the power output stage. The audio amplifier looks like the power amplifier except that it has a resistor in its plate lead instead of a transformer primary.

It must boost all the frequencies from 50 to 15,000 cycles in the same proportion, otherwise we get distortion. Sometimes a receiver needs two or more stages of audio frequency amplification. A complete audio amplifier system is shown in Fig. 1710.

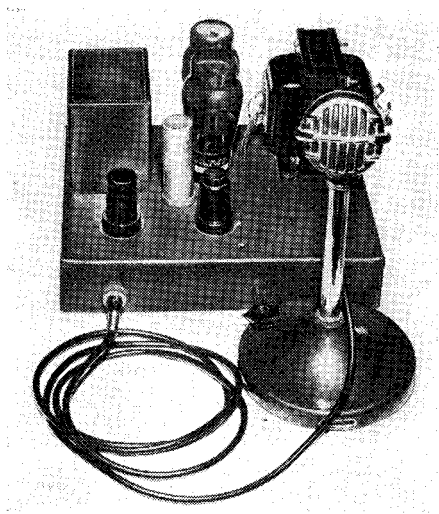

Fig. 1710—An audio amplifier having two voltage amplifier stages and push-pull output.

Related to the voltage amplifier is the push-pull amplifier, which is a power amplifier using two tubes to put out twice as much power as one tube will. Push-pull improves the output stage by canceling even harmonics which are introduced by the tubes.

Push-pull stages are found more often in the power output portion of a receiver than they are in the voltage amplifier section. As you will discover, push pull action can be had without using an input transformer, but that is a refinement that will be taken up later. Right now, Watson, slip your service revolver into the pocket of your great-coat, bring me my fore-and-aft cap and my magnifying glass, for we are about to start studying *detection!*

Demodulating the R.F.

IT would be nice if we could simply attach our audio amplifier to a receiving antenna and sit back and listen to a radio program rolling in loud and clear. Unfortunately, it is not that simple. Before our radio signal can be handled by an audio amplifier, it must go through a process called “detection” or, more accurately, “demodulation.”

You cannot explain the word “divorce” to a man who does not know the meaning of “marriage”; and, by the same token, before *demodulation* can be understood, one must know a little something about *modulation*.

Modulation

Modulation is the process by which the audio-frequency currents produced by a microphone are joined to the radio-frequency carrier currents generated by the transmitter. This truly is a marriage of convenience. The audio-frequency electromagnetic waves cannot travel through air for more than a few feet at most. Radio-frequency waves, on the other hand, can hop through space with the greatest of ease, but the ear will not respond to their rapid vibrations of hundreds of thousands of cycles per second. The obvious solution to the problem of transporting audio-frequency waves through space is simply to arrange some method by which they can ride piggy-back on earth-girdling radio-frequency waves from the transmitter to the receiver. Once they have arrived at their destination, the two can be separated and the audio-frequency currents used to drive our speaker. The gadget that does the separating is called a *detector* or *demodulator*.

The audio current modulates the radio-frequency carrier in much the same way that you can “modulate” the stream of water issuing from the nozzle of a garden hose by applying varying pressure to a kink in that hose. The audio voltage exerts a kind of “valving” action on the carrier that causes the amplitude of that carrier to vary exactly in step with the audio voltage.

Fig. 1801 shows graphically how the modulating audio voltage influences the carrier. The graph represents the way the voltage changes with time. At 1801-a we have an unmodulated carrier showing the cycles of radio-frequency current. For a station in the middle of the broadcast band, there would be about 1,000,000 per second. Fig. 1801-b shows a complex audio-frequency wave consisting of various audio frequencies of different intensities. At 1801-c we show the carrier wave "envelope" that results when the audio wave modulates that carrier. Note that when the audio signal is zero, our carrier is of normal amplitude. As the audio signal increases in a positive direction, the carrier amplitude increases just as does the amount of water issuing from the hose when you relax your pressure on the kink. As the modulating voltage increases in a negative direction, the amplitude of

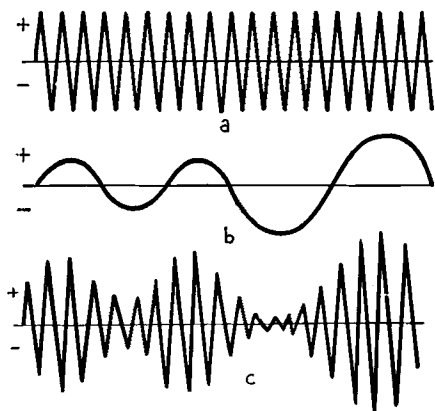

Fig. 1801—The r.f. carrier (a) is modulated by a.f. signal (b) to form the amplitude-modulated signal (c).

the carrier is greatly reduced, just as the water flow is reduced to a trickle when you clamp down on the hose.

This modulated carrier is the signal our radio set receives. You will notice that the frequency of the actual carrier remains unchanged. Only its amplitude changes. Under modulation the carrier develops a series of bulges and notches like the neck of an ostrich swallowing different-sized oranges. If the modulating voltage swings are strong, the bulges and accompanying dips are large; if this voltage is weak, the variations are barely perceptible. Also, if the modulating frequency is high, many of these bulges in amplitude appear in a short space of time; if low, only a few appear.

There is one marked difference between the audio voltage and the modulated carrier envelope produced by this voltage: the audio voltage appears first on one side of the zero line and then on the other so that

its force is exerted first in one direction and then in the opposite; but our modulated carrier expands and contracts simultaneously and similarly both above and below the center line (because a half-cycle of a.f. modulates many cycles of r.f.). That means that the equal and opposite voltages tend to cancel each other. The effect is about the same as if you held a strip of rubber in the center while someone pulled on the two ends with equal pressure. As far as you could tell by the feel at the point you were holding, nothing would be happening.

Demodulating the Signal

If we are to recover our audio voltage from this modulated carrier, we must find a way of changing this "two-way stretch" back into a one-way stretch. The method of doing this is simple: split the carrier in two right down the center and use half of it. Since the top and bottom halves are identical, either will contain all of the information needed about the original modulating voltage.

This "splitting" is not hard if we remember that top-and-bottom graph is just an engineer's way of saying that the current in the circuit flows one way half the time and the other way the other half. So what must be done is to *rectify* the r.f. current. That leaves us with a pulsating direct current; actually one with two sets of pulsations—those of the r.f. and those of the a.f.

We filter this pulsating current just enough to smooth out the r.f. peaks but not enough to bother the a.f. changes caused by the modulating voltage. Since the lowest radio frequency used in broadcasting is over 500,000 cycles per second and the highest audio frequency that can be heard somewhere around 15,000 cycles, that is easy.

Then we are left with a current whose pulsations reproduce those of the current which originally modulated the r.f. signal.

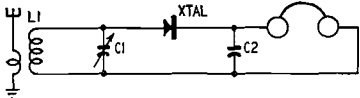

Fig. 1802—Circuit of a simple crystal set.

Fig. 1802 is a diagram of one of the earliest practical methods of detection. The crystal detector (indicated by XTAL) consists of a piece of galena (a common ore of lead) contacted by the sharp point of a phosphor-bronze wire called a *catwhisker*. It is a peculiarity of this tiny contact that it will allow current to flow easily from the catwhisker to the galena but presents a very high resistance to the flow of current from the galena to the catwhisker.

In our diagram the radio signal is picked up by the antenna and inductively transferred to the tuned circuit L1-C1. The alternating

radio-frequency voltage across this circuit is applied to the headphones *through* the crystal detector. Remembering that the crystal will allow current to flow in only one direction, we can easily see how half of our radio signal will be cut off as shown in Fig. 1803.

At Fig. 1803-a is the modulated carrier. This envelope is altered as shown in Fig. 1803-b by the crystal's refusal to pass pulses of current going in two directions. Only the pulses going *up* from the zero line are allowed to pass through. These pulses of current work together to charge capacitor C2 with a varying voltage as indicated by the dotted line of Fig. 1803-b. This capacitor discharges this varying voltage through the earphones.

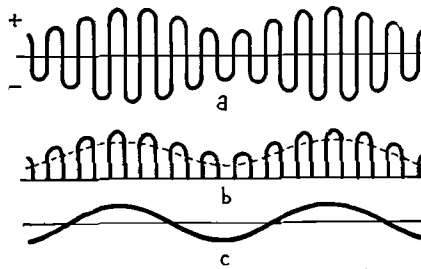

Fig. 1803—In detection, the modulated carrier (a) is cut in half (b) and the high frequency is filtered, giving us the original audio signal (c).

Since the charge of C2 is made up of the average of the voltage pulses contributed by the expanding and contracting carrier, the voltage on this capacitor looks like Fig. 1803-c. This voltage wave is a faithful reproduction of the original audio voltage that modulated the carrier. C2 and the coils in the headphone make up our r.f. filter.

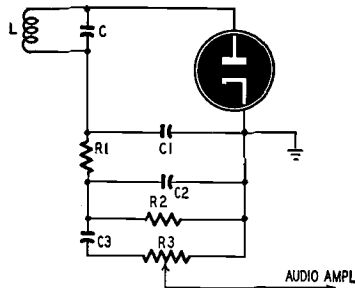

Fig. 1804—The vacuum-tube diode detector.

Catwhisker crystal detectors are seldom used these days. They are too hard to adjust and to keep in adjustment. The efficiency of the detector action is critically dependent upon the pressure of the catwhisker

on the crystal and also varies greatly from one spot on the crystal surface to another. Furthermore, the crystal detector does not handle either extremely weak or extremely strong signals very well. It has been superseded by the vacuum-tube diode type of detector diagrammed in Fig. 1804.

The Diode Detector

Although this circuit looks much more complicated, it functions just as did the crystal detector. The signal voltage appears across the tuned circuit L-C just as before, and the alternating r.f. voltage appears between the plate and cathode of the vacuum tube. While the plate is positive, as it is every half-cycle of r.f. voltage, electrons flow from the cathode to the plate. The more positive the plate swings, the more electrons it attracts. This means that when the carrier is expanding and the positive pulses of r.f. energy are increasing in amplitude, an increasing number of electrons go to the plate. When the carrier is decreasing and each pulse of voltage is weaker than the one just before it, the total electron flow decreases. The electrons actually flow in spurts as dictated by the evenly spaced positive pulses of r.f. voltage, but these

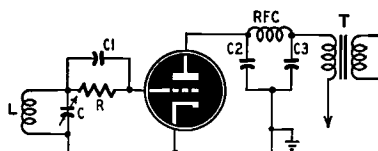

Fig. 1805—The grid leak detector is very sensitive.

spurts are blended together by the filter C1-R1-C2 to produce a continuous flow that follows faithfully the variations in the amplitude of the modulated carrier.

Electrons attracted to the plate from the cathode return to the cathode through L and resistors R1 and R2. Resistor R1, together with capacitors C1 and C2, act as a filter to smooth out the “spurdy” nature of the current delivered from the diode plate. The capacitors are large enough to offer a very low resistance bypassing action to the high-frequency variations resulting from the rectification of the individual r.f. pulses, but not large enough to have any material effect on the comparatively low-frequency variations resulting from demodulating the carrier envelope.

When this current, varying in accordance with the original audio voltage, flows through R2, it causes a voltage to appear across the resistor that is an exact reproduction of the original audio signal. Passing through capacitor C3, this voltage also appears across R3, the volume control. The slider on this control permits any fraction of the total audio voltage to be selected and passed along to the audio amplifier.

The Grid Leak Detector

While the diode detector is much like the crystal detector in its "check-valve" action, it was not the immediate successor of the crystal detector. The grid leak detector actually supplanted the galena and catwhisker combination. Fig. 1805 is a diagram of a triode grid leak detector.

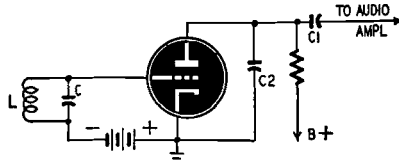

Fig. 1806—The power detector is biased to cutoff.

If you think of the grid as taking the place of the diode plate, you can see that the input portion of this circuit is really quite similar to that of our diode detector. The resistor across which the audio voltage develops has been moved to the grid leg of the input coil, and a capacitor is placed across this resistor so that the r.f. voltage can still be

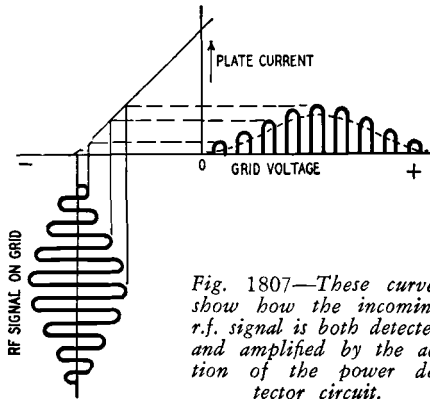

Fig. 1807—These curves show how the incoming r.f. signal is both detected and amplified by the action of the power detector circuit.

applied between the grid and the cathode; but we still have a condition in which the electrons will flow to the grid, just as they did to the diode plate, when that element is made positive by the half-cycle swings of r.f. voltage. The electron current to the grid, and consequently the voltage across resistor R—which is called the "grid leak"—varies in accordance with the amplitude of the modulated carrier.

The resistance value of the grid leak is sufficiently high (usually 2 to 10 megohms) so that the electrons attracted to the grid during the positive half-cycles of the r.f. carrier do not have time to leak off during the negative half-cycles; but it is at the same time small enough

so that the negative voltage on the grid can go up and down in unison with the changes in amplitude of the modulated carrier. This leaves only the audio signal on the grid.

Now stop thinking of our grid as a diode plate and look upon the tube as an ordinary amplifier. On the grid we have a varying voltage that exactly reproduces the audio voltage originally impressed on the carrier. The triode amplifies this audio voltage in the normal manner, and we have an amplified audio voltage across the primary of transformer T that leads into the audio amplifier. C2 and C3, together with the radio-frequency choke RFC, remove any trace of the radio-frequency ripple that might get through to the plate of the triode.

The grid leak detector is very sensitive because it combines the functions of detection and amplification. A pentode can be used in place of the triode to obtain still greater sensitivity. One big drawback of the grid leak detector is that, if it is made very sensitive to weak signals by the proper selection of values for the grid leak and the grid capacitor, it will distort strong signals badly.

The Power Detector

The "power detector" of Fig. 1806 will handle very strong signals without distortion. It looks like and is an ordinary amplifier circuit except that the bias is set so the tube is working very near the plate current cutoff portion of the curve, as is shown in Fig. 1807. Bias batteries are generally not used in practical circuits.

Since the plate current is practically zero with no signal on the grid, the negative swings of the r.f. voltage impressed on the grid have no effect on the plate current (it can't go below zero) but the positive half-cycles cause pulses of r.f. current to flow in the plate circuit as shown. These positive pulses of current increase or decrease in step with the amplitude of the voltage pulses on the grid. The charging and discharging action of capacitor C2 blends these separate pulses together into a varying current that rises and falls in step with the outline of the modulated carrier, as is shown by the dotted line. What we really have here is a combination of rectification (only the positive half-cycles of voltage affect the plate current) plus amplification. Since the grid bias is very negative, extremely large signals can be handled without overloading the detector.

This completes the types of detectors that have been used to receive amplitude-modulated radio signals. Each rightfully has enjoyed its day in the sun. The crystal detector had one decided advantage: it was entirely self-sufficient. No filament or plate batteries were needed to help it do its job.

The grid leak detector was much more sensitive—in fact, it is still the most sensitive of all detectors—but it could reproduce faithfully the audio portion of weak signals only. When the signal grew strong, the

sensitive grid leak detector was over-loaded and caused distortion in the signal.

The power detector can handle much larger signals without introducing distortion, and it is between the diode and the grid leak detector as far as sensitivity is concerned. What is more, since it causes no rectified current to flow through the tuned input circuit, it does not "load" this circuit and so reduce its sharpness of tuning. All other detectors mentioned do have this defect.

With the introduction of the pentode amplifier tube sensitivity in a detector became of little importance. R.f. amplifiers could easily build up a weak signal to almost any value before it was presented to the detector. That is why the diode, in spite of its low sensitivity, became the most popular detector. It is unbeatable in its ability to

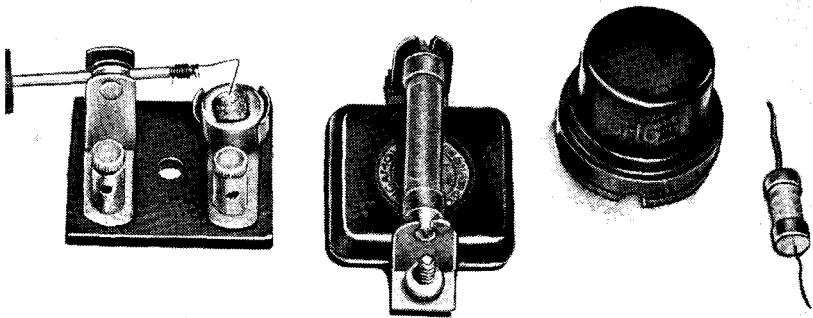

Fig. 1808—Detector history—crystal to crystal. Left to right—an old catwhisker detector; a grid capacitor with leak; 6H6 diode detector tube; germanium crystal diode.

handle any strength of signal without introducing distortion. What is more, it can do its job of detecting and, at the same time, produce other useful by-products, such as automatic volume control voltage which will be discussed in a later chapter.

Quite recently a new form of crystal detector has become popular. This is the tiny germanium crystal diode seen in the photograph, Fig. 1808. The catwhisker in this unit is sealed in permanent optimum adjustment, and it will handle much more current than would the old galena job. That frees it of the two main drawbacks of its ancestor.

Thus, once more we see demonstrated that amazing and oft-repeated cycle wherein one generation of radio engineers banishes a particular gadget to the electronic attic, and then the next generation hauls the item out of the garret, dusts it off, makes a few changes, and puts it back into use until something better comes along!

Chapter

19

Receiver Selectivity

A VERY young bird takes a lot of feeding and will swallow practically anything dropped into its gaping mouth. The detector stage described in Chapter 18 is much like this little bird: it requires a lot of signal to keep it going, and it will handle, without discrimination, almost anything fed into it.

But by the time a signal from a broadcast station reaches the receiving antenna it is usually about as strong as high-school prom punch; furthermore, two or three dozen broadcast signals may be on the antenna at the same time. If all of these signals were dumped into a detector, and if they were strong enough to be detected, a Duke's Mixture of voice, music, and sound effects would come out of the loudspeaker simultaneously.

To avoid such a bedlam, we need a special sort of selective amplifier between the antenna and the detector. Not only must this amplifier be able to build up the strength of received radio-frequency signals as an audio amplifier increases the amplitude of audio signals, but our radio-frequency amplifier must be able to select a particular broadcast signal from all those present on the antenna and amplify this one signal exclusively, while actually barring the passage of any other than the selected signal from the antenna to the detector.

Fig. 1901 reveals a simple way of doing this. It is a skeleton diagram of the basic elements of a tuned radio-frequency amplifier. The antenna circuit is inductively coupled to the grid circuit of the first tube by the air-core radio-frequency transformer T1. The secondary of this transformer is tuned by the variable capacitor C1. The current inductively coupled from the primary of T1 is actually introduced *in series* with the secondary and the capacitor C1.

A series-tuned circuit presents a very low impedance to its resonant frequency and a higher impedance to all other frequencies. This means that the current in the circuit is much higher at resonance, as is the voltage drop across both the coil and the capacitor. In fact, the drop across either one of these elements is higher than the applied

voltage; but at any other frequency than resonance, the voltage appearing across, say the capacitor, is greatly diminished, as shown by the resonance curve of Fig. 1902.

This means that the signal voltage applied to the grid of the first tube and the one amplified by that tube will be high *only* for the fre-

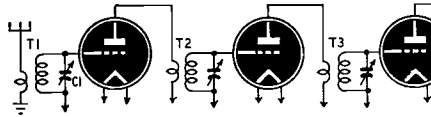

Fig. 1901—Basic tuned-radio-frequency circuit.

quency to which the tuned circuit is resonant. All other signal voltages in the primary will either be eliminated from the secondary or be greatly reduced. By varying the capacitance of C1 we can change the frequency to which our circuit is tuned and so select first one and then another broadcast signal to amplify.

Getting Better Selectivity

Unfortunately, a single tuned-radio-frequency stage seldom provides either the amplification or the selectivity necessary to receive a weak distant station without interference from a strong local one.

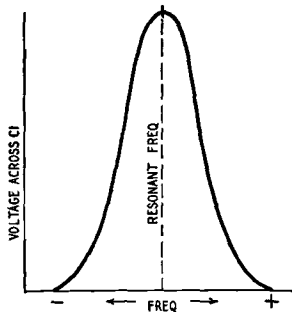

Fig. 1902—Frequency response of a single tuned circuit.

especially if the two stations are near each other in frequency. The problem is solved by following the advice Grandma used to give on the subject of keeping warm with petticoats: if one doesn't do the job, use more of 'em! Two or three r.f. amplifier stages are arranged one after the other as shown in Fig. 1901. Thus, each amplifier tube takes up the job of boosting the signal right where the preceding stage left off.

This explains why "cascaded" r.f. stages can be used to get the required amplification, and Fig. 1903 shows why the increased number of tuned circuits results in an improvement in selectivity. A band of frequencies of uniform strength is presented to the input of the

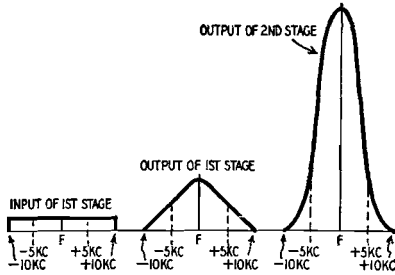

Fig. 1903—Cascaded r.f. stages will increase selectivity.

first r.f. stage. Because of the selective amplification of this stage, the output shows the frequencies 5 kilocycles each side of resonance are only one-half the amplitude of the resonant frequency F. Then, when this amplified signal gets to the next stage these 5-kilocycles-off-resonance frequencies are again amplified only half as much as the resonant frequency. Thus, since they were only half as strong to begin with, they are reduced to a strength only one-fourth that of the resonant frequency.

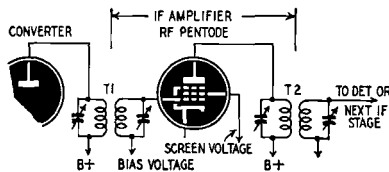

Fig. 1904—Circuit of a typical i.f. amplifier.

All the cascaded r.f. stages must be tuned to exactly the same frequency for most effective action. At first, each variable capacitor was adjusted by a separate dial. This made tuning the receiver too slow and complicated; so the tuning capacitors were "ganged," either by a system of pulleys and belts or by attaching the rotors of the capacitors all to the same shaft.

While this made it possible to keep the various tuned circuits "tracking" fairly close together as the tuning dial was rotated, there were always some discrepancies because it is practically impossible to manufacture identical capacitors and coils in mass production. Even

if it were possible, other metal objects near these units would change their characteristics when mounted in a receiver.

There are other faults in a tuned radio-frequency amplifier. For one thing, the efficiency of such an amplifier falls off as the frequency goes up and the losses that always accompany a rise in frequency increase. What is more, the selectivity also is variable. At 540 kc an interfering station 10 kc away from the frequency of the desired station has a separation of about 2% of the frequency; but at 1,600 kc, the

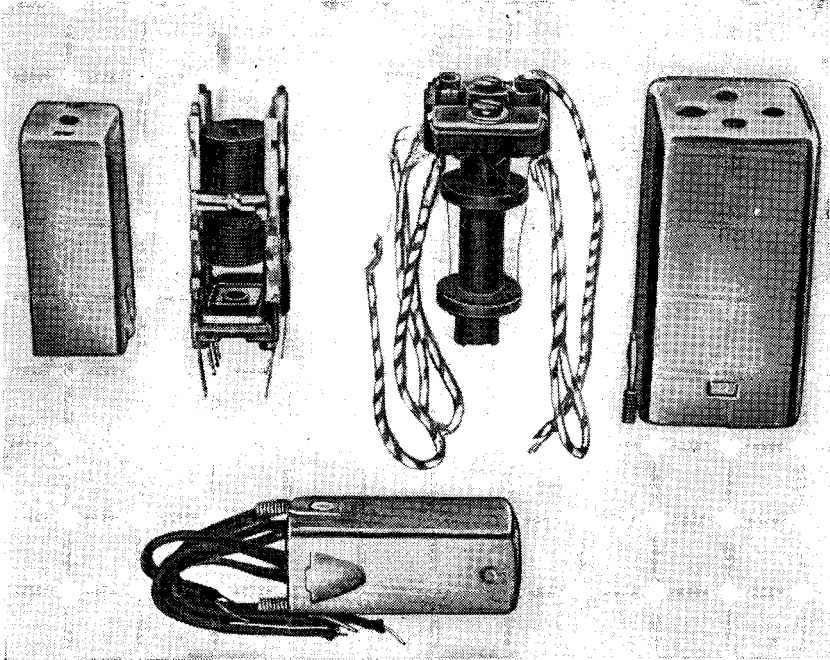

Fig. 1905—This photo shows three types of i.f. transformers. At right is a trimmer-tuned type; at left is a slug-tuned type; and in the foreground is a midget type

other end of the broadcast band, this same 10 kc represents little more than one-half of 1%. That means that a tuned radio-frequency amplifier does not do nearly so good a job of separating stations at the high end of the broadcast band as it does at the low. Moreover, a large number of separate variable tuned circuits make a receiver both expensive and bulky.

The Superheterodyne

A solution to almost all of these problems is to convert any frequency wanted to a single specified low frequency and then use a special one-frequency amplifier to do all the amplifying in this one

channel. This funneling of all broadcast frequencies into a single amplifier frequency has many advantages. For one thing, the single frequency can be lower than the lowest broadcast channel, and this low frequency improves both the amplifying efficiency and the selectivity. Since the amplifying is all done at the same frequency, irrespective of the frequency of the broadcast signal being received, this means more uniform selectivity and sensitivity. Bulky and expensive variable tuning capacitors can be replaced with inexpensive and compact semi-variable types, and shielding these smaller units is much less of a problem.

The superheterodyne receiver does all this. A single variable-tuned circuit is usually used to lead the desired signal from the antenna into a *converter* tube. Here the signal is converted to the *intermediate frequency*—usually in the neighborhood of 455 kilocycles—and then fed into the intermediate-frequency amplifier, which is diagrammed in Fig. 1904. At this point, let's not bother our pointed little heads about "how" this frequency-converting trick is accomplished. That will be explained to your complete satisfaction—let us hope—in a subsequent chapter.

You will note that the i.f. amplifier bears some resemblance to the r.f. amplifier; but the difference as the French deputy said about the differences between the sexes, is important. For one thing, both primary and secondary of the i.f. transformers are tuned. This gives four tuned circuits for only a single stage of intermediate-frequency amplification. Since we know that tuned circuits are what give an amplifier stage its selectivity, we are not surprised to learn that in most ordinary broadcast receivers a single stage of i.f. provides all the selectivity needed. It provides all the amplification needed, too. The low frequency used, the high efficiency of the transformer, and the high gain of modern radio-frequency pentodes all combine to give us i.f. amplifier stages with gains of 100 and better.

The photo Fig. 1905 shows how various types of i.f. transformers are constructed. Such transformers consist of two coils, usually mounted some distance apart and provided with screwdriver-adjusting semivariable capacitors for tuning each coil. Ordinarily a metal shield can completely encloses the transformer. Sometimes the coils are tuned by moving pieces of special metal in and out of their fields. In the transformer shown at the upper left of the picture, metal cups of this nature are screwed down over the coils to tune them. In other transformers of this *slug-tuned* type, slugs of this special metal are screwed in and out of the center of the coils to change their resonant frequencies.

Coupling

The coupling between the primary and the secondary coils—determined by the position and separation of the coils — is of the utmost

importance. Fig. 1906 shows why. Curve A represents very loose coupling with low current induced in the secondary, a current that peaks sharply at the resonant frequency. As the coupling is tightened, the current increases and the response curve keeps widening out until finally the curve of B is reached. At this *critical coupling* point, maximum current flows in the secondary at the resonant frequency. Moving the coils still closer together reduces the current at

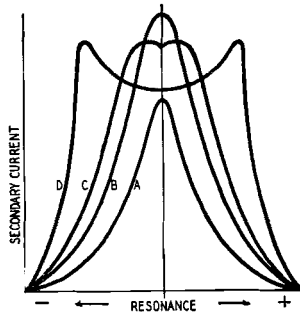

Fig. 1906—I.f. transformer bandwidth increases as coupling is increased.

resonance and increases current at frequencies on either side of the resonant frequency. Curves C and D, respectively, show the progressive double-humping effect of further tightening of the coupling.

This peculiar condition results as the coils are moved closer together because the secondary reflects more and more impedance into the primary and this reflected impedance combines with the primary's own impedance to displace the current peaks of the primary to each

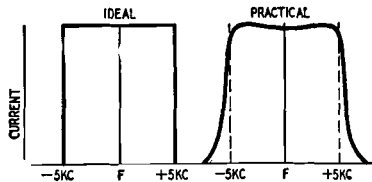

Fig. 1907—Illustration a at the left shows ideal response curve while b at the right shows practical curve.

side of resonance. And because the voltage induced in the secondary is directly related to the current flowing in the primary, similar twin peaks also show up in the secondary response curve.

Obviously if the coupling is too loose, very little signal is transferred from the primary to the secondary. On the other hand, if the

coupling is too tight, the selectivity goes to pot. Critical coupling is ordinarily the best all-around arrangement; however there are cases in which it is necessary to sacrifice maximum signal transfer for increased selectivity or deliberately to exceed critical coupling to widen the response curve.

How Much Bandwidth?

To understand why the sharpest response curve is not always the most desirable, we must absorb a new fact about the process of modulation: when a radio-frequency carrier is modulated by an audio-frequency note, two new frequencies called "sidebands," are produced, one on either side of the carrier. The frequencies of the sidebands are equal to the carrier frequency *plus* the modulating frequency and the carrier frequency *minus* the modulating frequency. For example, if we have a 1,000-kc carrier modulated with a 1,000-cycle (1-kc) note, the sidebands are at 999 and 1,001 kc. A 5,000-cycle (5-kc) note produces sidebands at 995 and 1,005 kc.

These sidebands must be received without serious distortion or reduction if the modulating information they contain is to come clearly from the speaker. That means that the i.f. amplifying channel must be wide enough to pass them. If only a 1,000-cycle note is used to modulate the carrier, an i.f. amplifier that is 2 kilocycles wide would be sufficient; but when music with high notes up to 5,000 cycles is received, the amplifier must pass a band of frequencies 10 kc wide to avoid distortion.

Various methods are used to widen the response curve of high-fidelity receivers to approach the ideal curve of Fig. 1907-a. The curve at 1907-b can be achieved by overcoupling, by loading the tuned circuits with resistors, by deliberately resonating the tuned circuits to slightly different frequencies—called "flat-topping"—or by a combination of these methods.

Defects in the I.F. Stage

I.f. amplifier troubles, outside of simple misalignment, fall into three broad classes: the stage oscillates; the response cannot be made sharp enough; gain is insufficient. Oscillation usually results from open bypass capacitors in the circuit, from poor shielding between the plate and grid circuits of the tube, or from a defective tube. Broad response results from defects in the windings of the i.f. transformer, such as shorted turns or high resistance, or from the coils having moved too close to each other. Defective windings may also produce low gain, as will windings that have slid too far apart or tuning capacitors that are shorted or defective so that they cannot resonate the associated winding to the proper frequency.

Chapter

20

The Converter Stage

DID you ever see sausage being made? A lot of different ingredients are tossed into the hopper of the meat grinder, but when they come out the other end of the machine, they are all sausage.

The superheterodyne receiver is a lot like this sausage grinder. The receiver can accept radio signals of widely different frequencies and convert them into a single "intermediate frequency" which will then pass through the i.f. amplifier. The grinder that reduces all the radio signals to a common denominator goes by the name of "converter" or "mixer" tube, and this chapter concerns itself with what kind of business goes on inside that tube. Two kinds of mixers are shown in Fig. 2001.

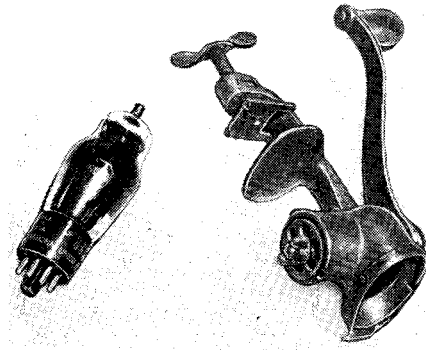

Fig. 2001—Mixers may vary widely in appearance.

The names applied to the tube give excellent clues to how it performs its presto-chango miracle: it "converts" the incoming signals of various frequencies into a single intermediate frequency, and it does this by "mixing" each of those incoming signals with another signal that is generated in the receiver.

Beat Frequencies

To understand why we can take a broadcast signal that is operating on, say 1,000 kc, mix it with another signal brewed in the receiver, and end with a signal exactly on the 455-kc intermediate frequency, we must explore the phenomena known as “beat frequencies.”

The authorities tell us: “If two or more alternating currents of different frequencies are present in an element having unilateral current flow properties, not only will the two original frequencies be present in the output but also currents having frequencies equal to the sum, and difference, of the original frequencies. These two new frequencies are known as *beat frequencies*.”

How a Mixer Works

Now that is just dandy, but we want to know *why*; so let us take a look at Figs. 2002 and 2003.

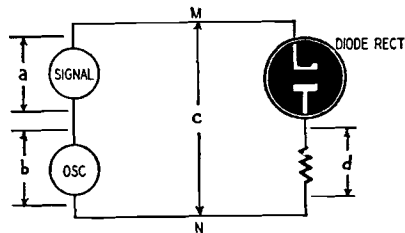

Fig. 2002—Diagram showing the elements needed in a converter.

Fig. 2002 shows two alternating-current generators, a diode rectifier tube, and a resistor, all connected in series. One of the generators is labeled SIGNAL and is operating at 12 cycles per second. The other, labeled OSCILLATOR, operates at 10 cycles per second. The reason for this name-calling will be given later.

Fig. 2003 portrays what takes place in various sections of the circuit of Fig. 2002. Fig. 2003-a shows the voltage output of the signal generator for a period of 1 second. At Fig. 2003-b we have the output of the oscillator generator *during the same second*.

Since the generators are connected in series, the voltage-across points M-N will be affected by voltages a and b from both generators. When the outputs of the two are in the same direction—that is, when corresponding terminals of the generators have the same polarity—the two voltages aid each other and the total voltage appearing across M-N is equal to the sum of the separate voltages. On the other hand, when one generator is positive while the other negative, the two voltages buck each other, and we have to subtract the negative voltage from the positive voltage.

Fig. 2003-c shows this interaction of the two generator voltages. The two voltages start out exactly in step, both rising from zero line; but since the signal voltage has to make 12 complete cycles during the time that the oscillator voltage is making only 10, they obviously cannot stay in step or "in phase." By the time voltage-b starts rising on the first quarter of its second cycle, voltage-a starts falling on the second quarter of its second cycle. When voltage-a is at the end of the first quarter of its fourth cycle, voltage-b is ending the third quarter of its third cycle. (See point O). The combined voltages are at minimum because voltage-a and voltage-b are bucking. However, by the time the oscillator voltage is rising on the first quarter of its sixth cycle, the signal voltage is also rising on the first quarter of its seventh cycle. The dashed lines, labeled A for aiding and O for opposing

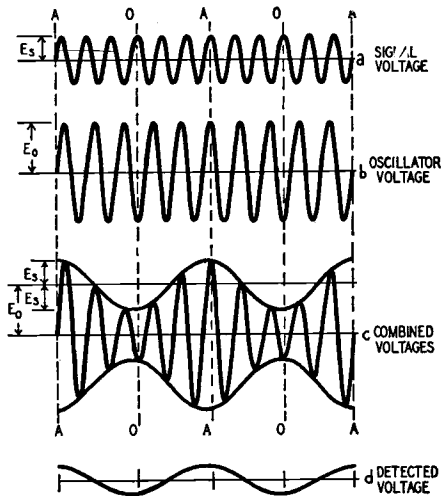

Fig. 2003—When the 12-cycle curve (a) is added to the 10-cycle curve (b) the result is a curve (c) modulated at the difference frequency of 2 cycles. Curve (d) is the detected voltage.

show that the output of the two generators aid and oppose each other at a rhythmic, regular rate; and this alternate helping-hindering action causes the amplitude of the combination voltage envelope shown at Fig. 2003-c to vary.

To see the matter from another angle, suppose we consider the analogy of two clocks, one of which goes tick-tock 40 times a minute and another which makes this sound thirty times a minute. At the beginning of the minute, both say "tick" so nearly at the same time that the result is a very loud sound. Then the ticks start drawing apart until finally one clock is saying "tick" at the same time the other is

saying “tock.” From that point on, the ticks start drawing closer together again until finally, at the end of 6 seconds, both clocks say “tick” simultaneously again, and we have another exceptionally loud sound.

This cycle repeats with a reinforced “tick” every 6 seconds. If we counted all of the ticks and tocks and then divided by 2, we should find that we had 70 tick-tock combinations per minute. The exceptionally loud ticks happen every 6 seconds; so we should have 10 of those per minute.

In other words, combining the 40-cycle-per-minute sound with the 30-cycle-per-minute sound, gives two new sounds: one is the sum of the two sound-frequencies, or 70 cycles per minute; and the other is the reinforced sound at 10 cycles per minute.

The positive and negative voltage peaks of our two generators combine in precisely the same way, and they also produce two new frequencies: one is equal to the sum of all the positive peaks plus all the negative peaks (of both generators) divided by 2—or simply the sum of the two frequencies; and the other, that results from the periodic reinforcing action of coinciding “in phase” peaks, is equal to the difference between the two frequencies.

Why Detection?

In Fig. 2003-c we see that the voltage envelope goes through a contraction-expansion cycle two times a second; and this frequency is the difference between the signal frequency of 12 cycles and the oscillator of 10 cycles.

But we must do something else to get our hands on this difference frequency. True, the two frequencies have been mixed and so the result is a voltage envelope that is modulated at the desired difference frequencies; but we must first extract that modulating frequency from the envelope.

That is where the “element having unilateral current-flow properties” come in. In Chapter 18 we learned that the way to recover modulation from a modulated envelope is to pass it through a “detector.” We also learned that a detector is a device that either passes current in only one direction or reacts much more enthusiastically to a voltage in one direction than it does to one in the opposite direction.

The diode tube of Fig. 2002 is such a device, for we know that current can pass through it only from the cathode to the plate. This means that only half of the envelope of Fig. 2003-c can pass through the tube and the resistor. As a result, the voltage d across the resistor will rise and fall right along with the outline of the top or bottom edge of 2003-c. Fig. 2003-d shows the alternating-current voltage that appears after the combined voltages pass through a detector.

Now that we know the *modus operandi* of mixing two frequencies

to get a third, let's try our hand on a practical circuit. Look at Fig 2004. A triode tube is connected as an ordinary grid-leak detector with a couple of important differences: between the bottom of L1 and the cathode is a coil that is inductively coupled to an "oscillator," and the primary of an i.f. transformer appears in the plate circuit. In the next chapter we shall take up in great detail the subject of oscillators, but for the present it is enough to know that an oscillator

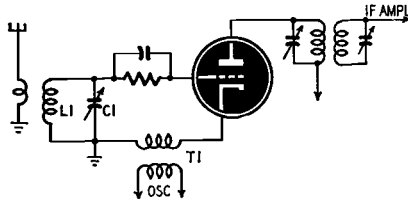

Fig. 2004—Circuit of a triode mixer. It looks almost like a grid leak detector.

is a generator of alternating current and can be made to operate on practically any desired frequency.

Now, suppose a radio signal of 1,000 kc strikes our antenna and appears across the tuned circuit L1-C1 resonated to that frequency. At the same time, suppose our oscillator is operating on a frequency of

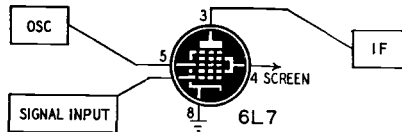

Fig. 2005—Circuit for frequency conversion with a mixer tube. This type of circuit needs a separate oscillator.

1,455 kc and that this frequency is delivered through T1 so that it appears between the bottom of L1 and the cathode. In other words, the 1,000-kc and the 1,455-kc frequencies are in series so that their combined voltages are presented to the grid circuit of the tube.

Our study of the similar circuit of Fig. 2002 tells us that this mixture of frequencies will result in a voltage envelope that is modulated at a frequency equal to the difference between the other two—in this case $1,455 - 1,000$ or 455 kc. We further know that when this envelope is passed through the detector tube, the modulating frequency will appear in the plate circuit. The tuned circuit of the i.f. transformer selects this "difference frequency" from the others that also appear in the plate circuit and starts it on its way through the i.f. amplifier.

If we want to receive a signal on 1,400 kc, we adjust our oscillator

to a frequency of 455 kc higher (to 1,855 kc), and once more the difference frequency is the required intermediate frequency. By the same token, a 600-kc signal can be converted to the i.f. frequency by mixing it with a 1,055-kc frequency from the oscillator.

Image Rejection

You are wondering why we bother with a tuned circuit connected to the antenna when we can change any signal to the intermediate frequency simply by parking the oscillator 455 kc away from that signal. You are forgetting one thing: *two* signals can be 455 kc from the oscillator frequency, one above it and one below it. For example, when we set our oscillator to 1,055 kc to receive a station on 600 kc, another station on 1,510 kc could also beat with our oscillator and produce a difference frequency of 455 kc. This would be accepted by our i.f. amplifier just as readily as one produced by beating with the 600-kc signal, and both signals would be heard at once. A tuned circuit that selects one of these signals and rejects the other is the solution.

In a practical modern receiver the tuning of the oscillator and of the signal input circuit are mechanically coupled together and so arranged that there is always a difference between them equal to the intermediate frequency of the receiver. Usually, in a broadcast receiver, the oscillator operates on the high-frequency side of the signal being received; so, if we have an intermediate frequency of 470 kc, the oscillator frequency is always 470 kc higher than the resonant frequency of the input circuit. Any station operating on the "image frequency" 470 kc higher than the oscillator frequency will be rejected by the input circuit that is always tuned 470 kc lower than the oscillator.

Some Modern Circuits

Modern receivers usually use mixer tubes specifically built for the job of frequency conversion. Such a tube is the 6L7 shown in Fig. 2005. In addition to the usual plate, screen, cathode, and suppressor elements, this tube has *two* input grids, both of which can control the plate current. That means that when the signal voltage is connected to one grid and the oscillator to the other, these combined influences determine the plate current, just as they did when both appeared together on the grid of our triode. The only difference is that the mixing now takes place in the electron stream instead of the grid circuit.

The tube operates over a nonlinear portion of its curve and so gives "power detection" action to the mixed frequencies. In Chapter 18 we learned detectors of this type are not sensitive to weak-signal carriers. A substantial portion of the bending part of the tube's curve must be brought into play to get unequal amplification of positive and negative peaks required for detection. A very small portion of the curve, such as used by a weak carrier, does not have enough bend to accomplish this.

In the 6L7 the local oscillator always furnishes a strong “carrier”—usually better than 20 volts peak-to-peak—and the strength of the signal itself merely determines the depth of the i.f. modulation impressed on this supplied “carrier.” A close study of Fig. 2003-c will reveal this is true. Thus we see that the oscillator voltage is not only necessary for mixing with the signal voltage, but also improves the efficiency of the detector part of our converter.

Pentagrid Converter

The 6L7, however, requires a separate oscillator tube; therefore the “pentagrid converter,” combining mixer and oscillator in one tube, is more popular. Fig. 2006 illustrates a 6A8 pentagrid converter in a typical circuit. Grid Nos. 1 and 2 (pin connections 5 and 6) form the control grid and anode, respectively, of a triode oscillator, with pulses

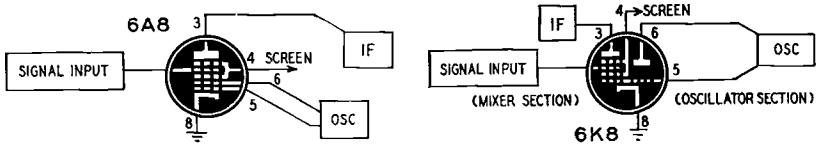

Fig. 2006—Pentagrid converter circuit. Fig. 2007—Triode-hexode mixer circuit.

of current flowing to grid No. 2 at the oscillator frequency. Not all of the electrons that reach grid No. 2 stop there, however. Some of these spurts of electrons continue on toward the plate and are further modified by the signal voltage impressed on grid No. 4 (signal input grid.) Thus the electron stream that finally reaches the plate has been shaped first by the oscillator frequency and then by the signal frequency. The detector action of this five-grid tube is like the 6L7’s.

Still another popular mixer is the triode-hexode 6K8 illustrated in Fig. 2007. In the envelope of this tube we have a triode oscillator and a hexode mixer. The grid of the oscillator section is connected internally to one of the two input grids of the mixer section and so causes the oscillator voltage to appear on that grid. The signal input frequency is connected to the other input grid, and the mixing and detection action from this point forward is quite like that of the 6L7.

You will meet various modifications of these basic mixer circuits from time to time, but you can unscramble them all if you keep the following in mind. When two a.c. frequencies appear together, they produce a voltage envelope that is modulated at a frequency equal to the difference between them. This difference frequency can be separated from the other two by passing the mixture through any one-way-action “detector” device.

Chapter 21

Some Oscillator Circuits

EVERY radio signal, from tiny coded “peeps” of the weather balloon transmitter to the output of a broadcast station, is born from an oscillator. After a radio signal has grown husky enough to leave the transmitting antenna, it soon meets a radio receiver. If this receiver is a superheterodyne—and the odds are better than a 1,000 to 1 that it is—the radio signal meets another little oscillator in the receiver. Our radio signal is no laggard in love and marriage takes place in a fraction of a microsecond. Out of this union is born a little intermediate-frequency signal that is the “spittin’ image” of its father; except that it is not so high.

The word “oscillator” comes from a Latin word that means to swing back and forth. The rocking chair and the clock pendulum are mechanical oscillators. If an empty rocking chair is given a push, it will continue to rock back and forth through decreasingly smaller arcs until it stops. A subsiding oscillation like this is called a “damped” oscillation.

If enough aiding power is delivered to a swinging object to overcome losses due to friction, air resistance, etc., the oscillation does not die out but continues as long as power is fed to it. Such a continuing oscillator (clock pendulum, for example) is called a “driven” oscillator.

When we think about an electrical counterpart of the mechanical oscillator, our mind naturally turns to a coil-across-capacitor combination. When a coil is placed across a charged capacitor, electrons rush from the negative plate through the coil. This current builds up a strong magnetic field about the coil. The collapse of this field continues to drive the electrons toward the plate that was positive, giving that plate a negative charge. Then the whole process is reversed. The electrons keep surging through the coil from one capacitor plate to the other until circuit losses finally succeed in damping the oscillation. The frequency of these oscillating current surges is near the resonant frequency of the tuned circuit.

If we can put more energy into this oscillating circuit—extra power

that will *work with* the oscillating current, we can replace the energy lost and so keep the circuit oscillating indefinitely, just as the tiny pushes given to the clock pendulum keep it oscillating. Since we can control the frequency of electrical oscillation by changing the resonant frequency of the tuned circuit, such an oscillator is an a.c. generator (a generator with no moving parts!) that will operate on any frequency we choose, even up to many millions of cycles per second.

The trick is to inject those little extra pushes of current with precisely the right timing so that they will aid rather than oppose the oscillating current in the tuned circuit; and when you consider that the current may be swinging back and forth a hundred million times a second, that might appear about as easy as trying to hurl an egg, intact, between the whirring blades of an electric fan. The feat is accomplished by connecting our oscillating tuned circuit to a vacuum tube so that the oscillations themselves trigger and direct the insertion of this “booster” energy.

Vacuum-Tube Oscillators

Fig. 2101 illustrates one way of doing this. L1-C1 is the variable tuned circuit. C2 applies the voltage appearing at the top of this

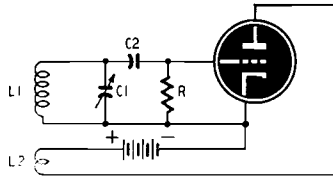

Fig. 2101—Simple feedback oscillator.

circuit directly to the triode grid. The grid leak R furnishes bias for the tube in a manner to be described later. Current flows from the cathode to the plate of the tube and then returns to the cathode through L2, inductively coupled to L1.

Suppose that a tiny disturbance in the grid circuit causes the grid to go slightly positive. This causes an increase in plate current. The magnetic field about L2 expands as this current increases and the lines of force cut the turns of L1 and induce a voltage in it. This voltage is of the proper polarity to add to the positive charge of the grid. A further increase in plate current results along with still more inductive coupling, or feedback, from the plate to the grid circuit.

This current-building-up process continues until the voltage drop across the reactance of L2 calls a halt. At this point the instantaneous voltage on the plate is so low that there is no further increase in plate

current even though the grid does go more positive. The magnetic field about L2 stops expanding and starts to collapse. This induces a reverse voltage in L1 so that the charge on the grid starts to move in a negative direction. This negative-going grid voltage aids the falling off of plate current, and the decreasing plate current, through the magnetic coupling, keeps driving the grid more and more negative.

Finally the plate current is zero and making the grid voltage more negative can produce no further change. Then the voltage ceases to be induced in L1 by L2, and the grid voltage starts to go positive again. The actual frequency of these reversing surges of current is determined by the resonant frequency of L1-C1. The energy fed back from the plate simply helps the charge on the grid to move in whichever direction it is going. To be sure these oscillations will be sustained, enough of this energy must be fed back to compensate for the losses in the grid circuit. The actual amount of feedback depends upon the amount of coupling between the circuit and the *tickler* coil L2.

The grid leak develops bias for the oscillator tube. While the grid is positive, it attracts more electrons than can leak off to ground during the part of the cycle in which the grid is negative. The electrons thus trapped on the grid give it a negative bias.

When the tube is not oscillating it has zero bias. The amplification is then maximum and the circuit is so unstable that the least disturbance will set into motion this chain of events that leads to sustained oscillation. Under the more stable conditions of fixed bias, the tube would be harder to start oscillating. Grid-leak bias automatically adjusts itself to the best value for sustaining oscillation when the load on the oscillator changes. If power is taken from the tank circuit and the amplitude of the voltage swings is reduced, the grid attracts fewer electrons, the bias is lowered, and the plate current increases. The heavier plate current surges help replace the energy lost from the tank circuit to the load.

Some Circuit Variations

While these basic principles are true for all oscillator circuits, there are many ways to apply them. Fig. 2102 shows some popular ones. We see in Fig. 2102-a (Armstrong oscillator), that the frequency-determining tuned circuit can be in the plate circuit instead of the grid circuit; or, as shown in Fig. 2102-b (Meissner oscillator), it can be in altogether a separate circuit that is inductively coupled to both the plate and grid circuits.

Fig. 2102-c (Hartley oscillator), reveals that two separate coils are not needed. Here the plate current flows through part of the tank coil. Inductive coupling between this part of the coil and the whole coil gives us transformer action just as if two separate windings were used. Fig. 2102-d is similar to the circuit of Fig. 2102-c. If you have trouble, at first, in seeing how 2102-d provides coupling between the

plate and grid circuits, just remember that the plate current also flows through the cathode circuit. The pulses of plate current appear between the tap on the coil and ground.

Fig. 2103 is known as the Colpitts. Here the cathode goes to a tap on a capacitive voltage divider instead of an inductive voltage divider, as it did in the Hartley. The amount of feedback depends upon the ratio of the capacitive reactances of C1 and C2. The Colpitts circuit

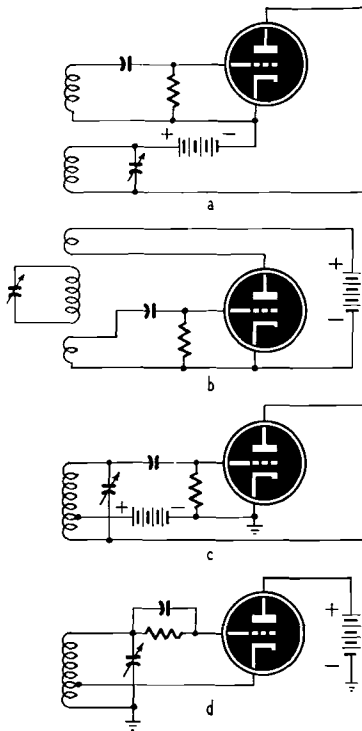

Fig. 2102—Some commonly used oscillator circuits.

is sometimes used in slug-tuned push-button oscillator circuits or for receivers working on the long-wave "weather" bands.

Incidentally, as the capacitance of the tuned circuit is increased, heavier currents circulate in the circuit and the losses go up. For this reason, an oscillator usually oscillates more vigorously on the high-frequency end. You must always provide enough feedback to make sure that the amplitude of oscillation is satisfactory at the low end.

However, you can get too much of a good thing; and feedback is no exception. If you have too much feedback, the oscillator is likely to develop a second, unwanted or parasitic mode of oscillation

that will put birdies to twittering on the signals as they are tuned in, especially on the high-frequency end of the band.

Oscillator Tracking

Tracking refers to the fact that the two tuned circuits shown in Fig. 2104 must follow certain tuning paths if our superheterodyne receiver is to work as it should.

You will recall that the oscillator frequency must always be spaced from the signal frequency you wish to receive by the intermediate frequency. Usually the oscillator operates on the high-frequency side of the signal. That means that if we wish to tune a band of 540 to 1620 kc, and if our i.f. is 455 kc, the oscillator must tune through a range of 995 to 2075 kc.

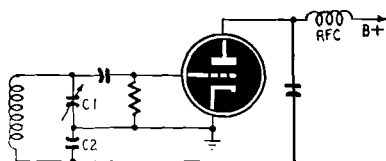

Fig. 2103—This Colpitts oscillator has a capacitive voltage divider.

In each case the total span of frequencies being 1,080 kc you might think that identical tuning capacitors on a single shaft, used with two different values of inductance, would accomplish our purpose of keeping the oscillator circuit always 455 kc higher than the signal input circuit. But you would be wrong. The spans of frequency are the same, but a ratio of 540 to 1620 kc is exactly 1 to 3, while from 955 to 2075 kc the ratio is slightly less than 1 to 2. If identical capacitor sections are used to resonate the two coils to frequencies 455 kc apart at the high end of the band, the gap between the two tuned circuits steadily narrows as the tuning capacitor is tuned toward the low-frequency end of the band.

One way to keep the tuned circuits 455 kc apart is to use a tuning capacitor with two sections having different shapes and sizes of plates. One section of this capacitor varies from 8.7 to 170.7 μf , while the larger section goes from 11 to 431 μf . When such a capacitor is used with proper coils, the oscillator will always be tuned 455 kc higher than the signal input circuit for any setting of the capacitor shaft.

The Padder Capacitor

This method, unfortunately, can only be used on a single band—unless you want to use more than one tuning capacitor! However, a padder capacitor together with a capacitor section that has uncut

plates can make that section seem as though the plates were tailored to the oscillator circuit needs; furthermore, different padders can be used on different bands so that the same tuning capacitor section can be used to track the oscillator correctly on each of these bands.

Fig. 2105 helps understand how this is done. The tuning capacitor C_t and the padding capacitor C_p are in series across the coil. When two capacitors are in series, their total capacitance is equal to their

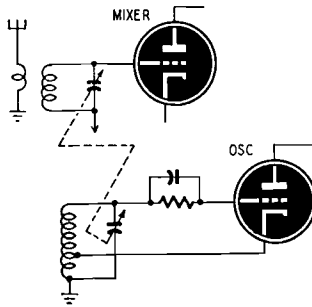

Fig. 2104—In the superbet, the oscillator and mixer tuning capacitors are on one shaft as indicated by the dashed line.

product divided by their sum. Let us assume that the maximum capacitance C_t is 431 μmf , just as is the section tuning the signal input circuit. C_p is a semivariable capacitor adjustable by a screwdriver. If we adjust this capacitor to about 280 μmf , we find that the series combination of C_t and C_p is very close to the 170.7 μmf maximum capacitance furnished by the cut-plate section of the other tuning capacitor.

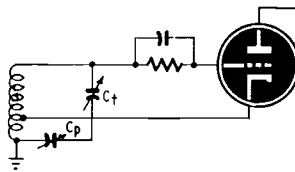

Fig. 2105—For correct tracking, a padder capacitor is used in series with the tuning capacitor.

As the frequency of the oscillator is tuned higher, the fixed capacitance of C_p has less and less reactance. At the same time the reactance of C_t steadily increases. By the time the high-frequency end of the band is reached, the reactance of C_t is so much greater than that of C_p that the tuning capacitor is almost entirely responsible for

the tuning of the oscillator circuit. As the circuit is tuned toward the low-frequency end of the band, however, the padder capacitor reactance has more of a "hobbling" action on the tuning capacitor and makes the effective maximum capacitance much less than it would be without the padder. By using the proper value of inductance and the proper padder, an oscillator circuit may be made to track exactly at three different points in the tuning range. Deviation from the exact frequency at other points is negligible.

Oscillator Troubles

Oscillator failures are usually due to defective coils, bad grid-coupling capacitors, or defective grid-leak resistors. The best way to check an oscillator is to measure the negative voltage on the grid with a vacuum-tube voltmeter. No voltage indicates an oscillator that is not functioning, and the amplitude of the voltage at different settings of the tuning capacitor reveals whether there are any weak spots in the oscillator's output. Some falling off in output is to be expected as the oscillator is tuned to the low end of its range.

Chapter 22

How to Trap a Signal

BEFORE we set out to trap a signal we should have some idea of the characteristics of the game we are after. The “game” in this instance is a transmitted signal; and, while its characteristics are more complicated than the rules for playing postoffice, they are by no means beyond comprehension.

We know that when 60-cycle a.c. flows through a wire, the conductor is surrounded by a changing magnetic field. Part of the electrical energy is alternately stored in this field and then returned to the wire. If the frequency is increased to 10,000 cycles a second and beyond, some of the energy delivered to the field about the wire does not return to the conductor but sails off into space as radiated energy. When a transmitting antenna is substituted for our conducting wire encouragement is given to the a.c. energy to leave home and keep going.

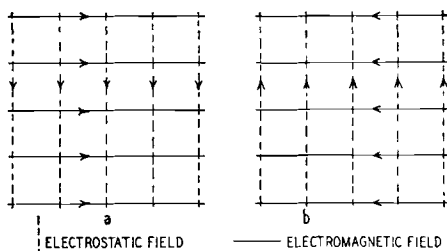

Fig. 2201—Patterns showing the electromagnetic and electrostatic fields of force of a radiated signal.

Fig. 2201-a gives us a head-on view of this free-wheeling radio wave as it zips through space directly toward us at a speed of 186,000 miles a second. Notice that there are really two fields, which share the energy of the wave equally between them: an *electrostatic* or “voltage” field, and an *electromagnetic* or “current-inducing” field. These two

fields are inseparable and always act at right angles to each other. Both operate at right angles to the direction of travel.

Broadcast-band waves ordinarily have their electrostatic fields producing lines of force in a vertical direction with regard to the earth and are said to be "vertically polarized." Television stations in the United States send out waves whose electrostatic stress is exerted parallel to the earth and are called "horizontally polarized" waves.

At the instant pictured in Fig. 2201-a, the electrostatic stress is from top to bottom, and the electromagnetic stress is from left to right. Fig. 2201-b pictures the same wave passing the same place at a time interval equal to one-half wavelength later. Note that by now the electrostatic stress is from bottom to top and the electromagnetic stress is from right to left.

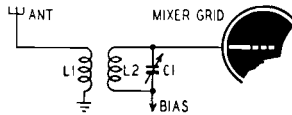

Fig. 2202—Antenna circuit inductively coupled to mixer grid.

The thing to keep clearly in mind is that these two fields are *moving* and that as they move past a stationary portion of space they produce stresses in that space. For example, as the electrostatic portion of the wave encounters two points in space, one directly above the other, first the top point will be positive with respect to the bottom point and then vice versa. If the two points are connected by a length of wire, an alternating current will flow in this wire as the radio wave zips past it.

Snaring the Signal

Fig. 2202 shows how we take advantage of this fact to trap a signal for our receiver. A vertical wire is connected through coil L1 to earth. The top of this antenna and the earth constitute the two "points in space" mentioned previously. The current flowing in L1 is inductively coupled to tuned circuit L2-C1. By resonating this tuned circuit to the signal we want to receive, we can reject all other signals flowing in the antenna circuit and allow only the wanted one to appear on the grid of our mixer tube.

This "outside" antenna provides a good method of intercepting a radio signal, but it has disadvantages. First, since its effectiveness depends to a large degree on its height, it is difficult to install; second, special precautions must be taken to prevent this elevated antenna from extending the welcome-mat to a bolt of lightning; third, few antennas of this kind do anything for the appearance of a home; and

fourth, a radio needing such an antenna is rooted to one spot near where the lead-in is brought into the house. Fortunately the necessity for outside antennas for broadcast-band receivers has been eliminated.

As can be seen from Fig. 2203, the modern *high-impedance loop antenna* is really an expanded antenna transformer. Instead of occupying only a couple of inches of space, the secondary of the transformer is wound in the form of a spiral or large diameter helix so that it has

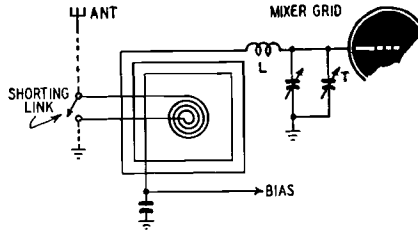

Fig. 2203—*High-impedance helix-type loop antenna.*

an area of many square inches. In this enlarged form, it can intercept a sizeable portion of the field of a radio wave and so provide sufficient signal for the receiver without an outside antenna.

Directional Properties

Such a loop antenna is directional; it will receive a signal much better when the loop is arranged so that its plane is paralleled to the line of transmission of the radio signal than it will when this plane is

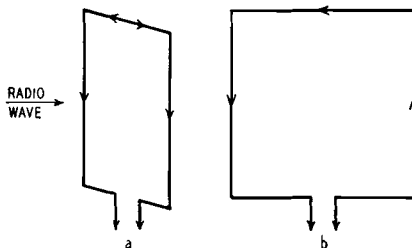

Fig. 2204—*This diagram shows the directional properties of the loop antenna.*

at right angles to the line of transmission. If you will look at the simplified one-turn loop shown in Fig. 2204, you can see why. At 2204-a the incoming signal strikes both sides of the loop simultaneously. The currents induced in the two sides of the loop by the passing magnetic field—the loop depends upon the electromagnetic field of the radio wave for its action—are equal and opposite in phase; so they simply

buck each other and the signal is received very weakly if at all.

At 2204-b, however, the wave strikes one side before the other. If you keep in mind that, as the wave moves through space, its fields are constantly shifting back and forth, you can see that the direction and intensity of the current induced in the first leg of the loop cannot be identical with the direction and intensity of the current induced in the second leg, because the wave has traveled through space between these two encounters and the electromagnetic field that produces the current has changed somewhat during that short trip. Since the two currents are not identical, they cannot balance each other out, and we shall have an alternating current flowing in our loop. Do not think that the two currents are *in phase* when the loop is parallel to the line of transmission—the loop would have to have its two sides a half-wavelength apart for that—but they are not 180 degrees out of phase as they are when the plane of the loop is at right angles to this line. This slight shift away from the 180-degrees-out-of-phase condition is all that is needed to let a signal be received.

The voltage pickup is proportional to the loop area. The farther the loop is located from the chassis or any other large metal object, the lower is its distributed capacitance, the higher is its Q , the sharper it

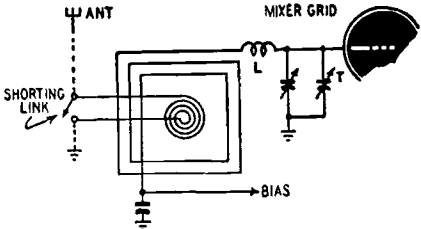

Fig. 2205—Adding a loading coil L to the loop antenna gives it better response.

tunes, and the more directional it is. Unfortunately, the usual small receiver permits the loop to be placed only an inch or so from the chassis. One way of overcoming some of these disadvantages is to have the loop detachable from the receiver and arranged so that it can be held in the best position by suction cups.

Improved Loop Antennas

An approach that is more electronic and less mechanical is diagrammed in Fig. 2205. Here a loading coil L is used in series with the loop. This loading coil has a high Q and a low distributed capacitance. Since the distributed capacitance of the loop circuit is thus reduced, the tuning range of the loop is extended for use with a given capacitor. Raising the Q of the tuned circuit gives sharper tuning and better signal response. In many receivers, this loading coil is slug-tuned for best tracking over the tuning range.

Provisions are usually made for connecting an outside antenna to these loops for receiving distant or weak stations. A low-cost way of doing this is to place a single turn of wire around the loop at the low-potential side as is shown in Fig. 2203. Such an arrangement favors the high-frequency end of the band, but that can be overcome by inserting a resistor of 500 or 1,000 ohms in series with the single turn. If too much coupling is provided, the signals tend to be hum-modulated and the selectivity suffers.

A high-impedance primary, shown in Fig. 2205, gives more uniform coupling than does the single-turn job of Fig. 2203, but is guilty of the cardinal sin of manufacturing: it costs more! When such a high-impedance primary is used, it is usually provided with a shorting link to be used when an external antenna is not connected. This is to prevent the absorption of energy by the primary coil at its resonant points that fall in the broadcast band.

One manufacturer has still another system for getting around the disadvantages of the high-impedance loop. He uses a low-impedance

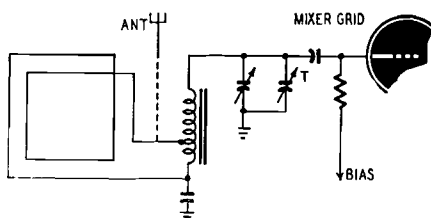

Fig. 2206—By using only a few turns on the loop but coupling it to the mixer through a high Q autotransformer, the antenna response can also be improved.

loop, as shown in Fig. 2206, which consists of two to four turns of large-diameter wire. This is inductively coupled to the grid of the mixer tube through a very high- Q autotransformer. The low-impedance loop is relatively insensitive to capacitance effects and to calibration changes due to changing its position. Both the Q and the response are practically uniform throughout the broadcast band. An external antenna, when used, is connected directly to the high-potential side of the loop.

Many of the better receivers place loop antennas inside electrostatic shields. This serves the double purpose of cutting down on much man-made interference and of insuring uniformly distributed capacitance effects for the loop.

The directional properties of a loop antenna are fine for cutting down on interference, either from an unwanted radio station or from a noise source that occupies a single point in space.

IN the last chapter we implied that waves traveled a straight path from transmitting antenna to receiving antennas. That is not the case!

Ground Waves

Fig. 2301 shows what happens. Some of the waves from the transmitter at A follow the surface of the earth like the one designated G. These "ground waves" induce currents in the earth, and the resis-

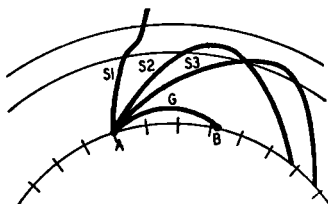

Fig. 2301—How radio waves act in space.

tance of the earth causes them to die out rapidly, particularly at higher frequencies. On the broadcast band these waves account for daytime reception. They are good for about 50 miles at the high-frequency end of the band and up to 200 miles at the low-frequency end.

Sky Waves

Then there are "sky waves" that travel upward from the transmitter at angles, as shown at S1, S2, and S3. Some of these, like S1, keep traveling, never to be heard from again. Others, like S2 and S3, meet "something" up there that persuades them to turn back to earth.

The "something" that turns them back is a series of ionized layers above the earth's surface at distances from 30 to 250 miles. Gases

in the upper atmosphere, bombarded by ultra-violet and cosmic ray radiation, become ionized. Since these gases hover at various heights according to their weight, and since the bombardment is more effective as the atmosphere becomes rarer, the ionization is in layers, each layer being more ionized than the one below it.

Radio waves are bent when they pass through an intensely ionized layer. The wave behaves as though it hates ions and wants to avoid them. This is shown in Fig. 2302. As the radio wave enters the ion-

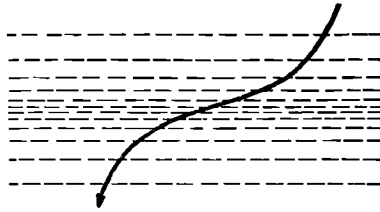

Fig. 2302—Wave path in an ionized layer.

ized layer, it moves away from the deeply ionized portion of the layer; but once it is forced to pass through this center portion, it reverses its direction of curvature so as to escape from the layer quickly.

The amount of bending depends upon the angle with which the radio wave strikes the layer, the wave frequency, and the intensity of ionization of the layer. If the wave strikes the layer nearly at right angles, as shown at A in Fig. 2303, there is little bending. As this angle

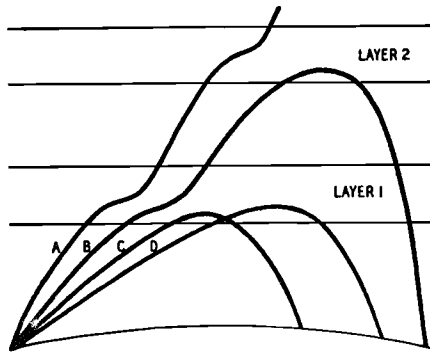

Fig. 2303—The amount of bending depends on the angle at which the wave strikes.

decreases, the bending becomes more pronounced, as illustrated at C and D. A low-frequency wave bends or "refracts" more than one

of higher frequency. If a wave strikes the layer at an angle that just permits it to be bent back to earth, a higher frequency wave will pass through. Often a wave will penetrate a lower layer only to be turned back by the increased ionization of the layer above it, as pictured at B.

The subject of what happens to a radio wave in the ionosphere is complicated. All we need know is that sky waves can be bent back to earth; that most broadcast-frequency sky waves are absorbed during day time but are not absorbed at night; and that the spot to which a wave returns depends upon several variable factors.

Fading

And now we are ready to take up *fading*. As the curtain rises on this drama, we see the transmitting antenna. The ground wave is saying to the sky wave, "You take the high road and I'll take the low road, and I'll get there before you." It is this choice of paths from the transmitter to the receiving location that causes trouble.

If the receiver is near the transmitter, reception is dominated by the ground wave and is not affected by sky waves from the ionosphere. As the distance from the transmitter increases, the ground wave grows weaker until it cannot be heard. At this point and beyond, the station cannot be received in the daytime. At night the waves "reflected" from the ionized layers permits reception.

Where the sky wave and ground wave are received equally well, we have an area of bad fading. Since the two portions of the same signal cover different distances, they may arrive with a difference in "phasing" that will cause them to add or to buck one another. In the first case, the resulting signal will become stronger; in the latter the two portions may so cancel that nothing can be heard. Since the path the sky wave travels changes with shifts in the height and ionization of the refracting layer, the signal may vary between these two extremes.

You might think that once the receiving station was beyond the reach of the ground wave, fading would end, but such is not always the case. The wave-bending ionosphere is unstable and the path of a wave through this ionosphere is constantly changing. At one time the receiver may be getting the full intensity of the refracted wave, while a few minutes later this center of intensity may have shifted miles away.

What is worse, the sideband frequencies of the wave may travel different paths in the ionosphere and when they arrive at the receiver the phase of these intelligence-carrying sidebands may be different from what they were at the transmitter. Music or voice may be garbled by the interaction of these out-of-phase sidebands. This brand of fading accompanied by distortion is called "selective fading."

Automatic Volume Control

The cure for fading, once found, was simple. *Automatic volume control* was the poor name selected for it, “poor” because any attempt to hold the volume at a constant level—making the whisper of the flute as loud as the bellow of the tuba—results in distortion. What was done was to make the r.f. sensitivity of the receiver inversely proportional to the intensity of the signal. As the signal intensity goes up, the receiver sensitivity goes down, and *vice versa*. The result is that the signal delivered to the detector is practically independent of variations in the strength of the received signal. A. v. c. will not cure the “selective” type of fading, however.

Control is secured by varying the bias voltage applied to the r.f., mixer, and i.f. stages. As the negative bias on the grids of these tubes is increased, their ability to amplify is decreased, and the sensitivity of the receiver is reduced. Since we want this bias voltage to rise and

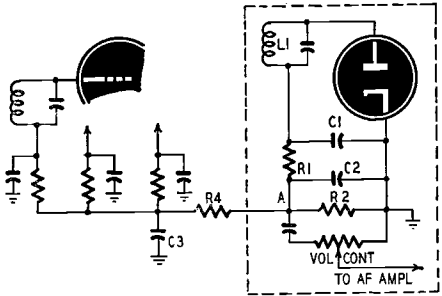

Fig. 2304—A detector circuit with a.v.c.

fall with the strength of the received signal, the best place to get such a control voltage is from the signal itself.

Fig. 2304 shows how this is done. The diagram inside the dotted lines is the diode detector. Rectifying action of the diode causes three currents to flow down through L1: first, pulses of rectified r.f. carrier that are filtered R1, C1, and C2; second, audio fluctuations that appear across R2; and third, the d.c. voltage produced by the one-way movement of electrons through R2 to ground. This last voltage is the one we are interested in.

The d.c. voltage drop across R2 is produced by rectifying the carrier envelope; so it is directly proportional to the amplitude of the carrier. If this amplitude increases, point A becomes more negative with respect to ground; if it decreases—another way of saying the signal intensity goes down—point A becomes less negative.

Before this controlling voltage can be used, we must comb out the a.f. variations still present at point A. This is done by means of filter R4-C3.

The values of this resistor and capacitor are carefully chosen and should not be changed. When a capacitor charges and discharges through a resistor, the time required for the voltage to build up and fall depends upon the values of the two components. What we want is a combination that will be too slow to follow the voltage variations caused by the lowest audio frequency but fast enough to let the system have time to “recover” when we tune our set. Otherwise, when tuning from a strong station past a weak one, the sensitivity of the receiver might not have time to adjust itself after leaving the strong station, and the weak station would not be heard. The usual time constant is 0.1 second.

This negative voltage is fed to the grids of the controlled tubes through resistors that prevent coupling between the grid circuits. Tubes controlled by a.v.c. are the “remote-cutoff” type. These tubes are provided with a certain amount of minimum fixed bias—such as cathode bias—so that the plate current does not become excessive when no a.v.c. voltage is being produced.

Delayed A. V. C.

In ordinary a.v.c., controlling action starts on the weakest signal and reduces the gain of the receiver when increased sensitivity would really help. “Delayed a.v.c.,” as diagrammed in Fig. 2305, shows the circuit for overcoming this problem. Diode D1 is used for detection. The i.f. signal is also applied, through C1, to D2. The cathode of D2

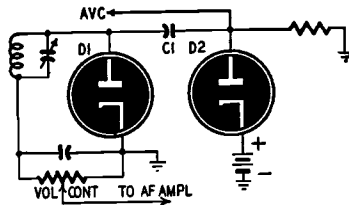

Fig. 2305—A basic delayed a.v.c. circuit

is positive with respect to ground, which makes the plate negative with respect to the cathode. As long as the peak amplitude of the i.f. signal applied to D2 is less than this bias voltage, there will be no rectification, and no a.v.c. voltage. As soon as the peak i.f. voltage rises above this bias voltage, rectification begins and the a.v.c. voltage is developed.

A. V. C. Troubles

A.v.c. troubles are usually due to failures of capacitors, resistors, or diodes in a.v.c. circuit. Since the voltages are fed to the grids of

the tubes through high-ohmage resistors, even a slightly leaky capacitor, will short-circuit the a.v.c. voltage.

A worse trouble is an intermittently leaky capacitor, which will produce its own type of fading. Where the complaint is "fading" or "intermittent," it is a good idea to replace all capacitors in the a.v.c. circuit and to make sure the resistors are not changing their value.

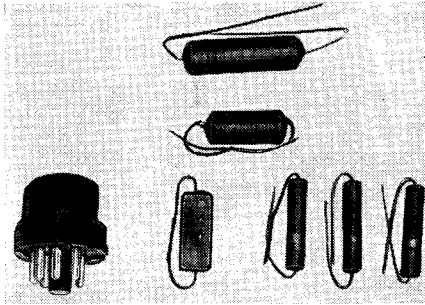

Fig. 2306—Only a few components are necessary for a complete a.v.c. system.

As shown in the photo, Fig. 2306 above, a few simple parts are required to form an a.v.c. system. A few resistors, capacitors, and a diode, are all that are necessary.

Chapter

24

Receiver Refinements

THE element common to the various tube circuits is the metal chassis. In most receivers that use power transformers, this chassis acts as the ground for the set. A connection between chassis and earth is often recommended.

What is "Ground?"

"What is a ground, and why do we have 'em?"

Ground is *not* necessarily the point to which B-minus is connected for B-minus is often connected as shown in Fig. 2401 so that we may use a portion of the B-voltage for negative bias on the output tube. In Fig. 2401, plate current through R2 leaves point A negative

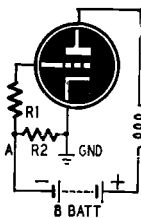

Fig. 2401—In the circuit shown at the left, the B-minus connection is not the same as ground. This type of connection is most often used in audio power output circuits to supply bias voltage for the output tube. In this illustration, the voltage drop across R2 furnishes bias for the tube. In a receiver using this circuit, the common connecting point is B-minus and not ground.

with respect to the grounded cathode. This negative voltage is transferred to the grid through R1. Nor can we say that ground is the part of the circuit to which the cathode is connected. We are not safe in assuming that it is the chassis itself, because in a.c.-d.c. sets the set-ground is actually one side of the power line, as shown in Fig. 2402.

Since the chassis is usually anchored in the cabinet with exposed bolts which can be touched by the set owner, it is simpler and safer to use a common ground lead for all circuits but to isolate this lead from the chassis itself. Both the chassis and this isolated lead are grounds, for which B-minus and most bypass capacitors are usually

connected to the common lead, the various shields of the receiver are grounded to the chassis. The two grounds are usually connected by a $\frac{1}{4}$ -megohm resistor bypassed by a capacitor of 0.1 to 0.25 μf .

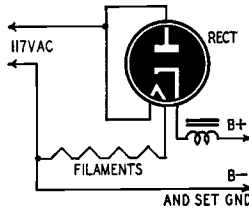

Fig. 2402—*B-minus is connected to one side of the a.c. line.*

A receiver ground is made up of all points of the circuit that are intended to be at zero signal potential at all times, and is the reference point from which all tube potentials—bias, screen, plate and cathode voltages—are measured. While it may or may not have an actual d.c. conducting connection to the earth, it ordinarily has a capacitance path to ground, as is shown in Fig. 2403.

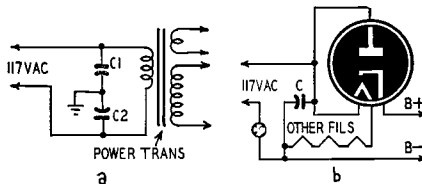

Fig. 2403—*Capacitance ground circuit for an a.c. and for an a.c.-d.c. receiver.*

At “a” we have the a.c. input circuit of a transformer-type receiver. C1 and C2 connect across the power line to the receiver. Since one side of the line is always connected to the earth, the chassis will always be grounded through one capacitor or the other. At “b” of Fig. 2403, a capacitor across the line insures a connection to the earth, no matter which side of the line is connected to the set-ground of an a.c.-d.c. receiver.

All the tube circuits share a single ground connection to provide a common footing that permits easy transfer of energy from one stage to another.

Without such a common connection, the receiver would be like a bucket-brigade in which the members were all wearing roller skates; a man trying to pass a bucket of water in one direction while his feet are going in the other—a very low transfer efficiency!

Consider Fig. 2404. We want to transfer the signal across resistor R1 to resistor R2. Capacitor C offers one path for this transfer, but electricity will not leave home unless it has a round-trip ticket. A return path must be provided. The two grounds, both soldered to a common lead or the common metal chassis, provide such a path, as indicated by the dashed line.

It might seem that since the chassis serves as a link between all the stages and since various signals are passing from one stage to another through it, that there would be confusion caused by sharing of a common path. Two things prevent this: first, the ground of a receiver always has low resistance; currents through it encounter practically no impedance to dam their passage, and so will not permit

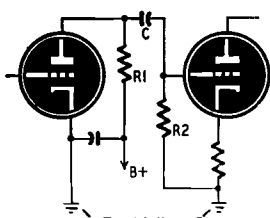

Fig. 2404—The broken line indicates how the chassis makes a complete circuit.

them to build up individual potentials. Second, this ground always has some connection to earth, and the earth can absorb an excess of electrons or supply them. Since a voltage is always produced by too many or too few electrons, this neutralizing earth-ground will prevent any such voltage from developing.

It is as though we had several high-pressure streams of water shooting into the Atlantic Ocean on this side and an equal number of high-pressure pumps drawing water out of the English Channel. While we could say that water was being transferred across the sea, no currents could be traced from one pump to another across the vast expanse of water. In the same way that the streams of water are all reduced to zero-pressure value in the ocean, so are all signals reduced to a common zero-potential figure for their passage through the ground leads of a receiver.

Tuning Indicators

A good service technician listening to a receiver that is slightly off-tune is affected in the same teeth-on-edge way that many people feel when they hear a piece of chalk squealing on a blackboard. Even inexpensive a.c.-d.c. receivers must be tuned in carefully to avoid serious distortion.

The better the selectivity of the receiver, the greater the impairment of tone caused by improper tuning. To avoid this trouble many receivers are equipped with devices to indicate visually when the set is exactly tuned.

A simple form of such indicator, diagrammed in Fig. 2405, consists

Fig. 2405—The circuit at the right illustrates a simple form of tuning meter. The a.v.c. voltage applied to the control grid of the tube will be greatest when the receiver is carefully tuned for maximum signal. Since the a.v.c. voltage is negative, the current through the tube will be minimum when the signal is maximum. Hence the receiver should be tuned for minimum reading on the current meter.

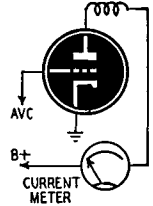

of a current-indicating meter in the plate circuit of a tube whose bias is controlled by the a.v.c. system. Full a.v.c. voltage is developed when the receiver is tuned to the exact center of the carrier; so when our meter indicates minimum current we know the receiver is tuned exactly. There are many variations of this idea: the meter may read the plate current of two or more controlled stages; it may be placed in the cathode circuit; it may be used in conjunction with a bridge circuit so that it will read forward instead of backward to indicate maximum carrier strength, etc.; but the principle remains the same.

Electron-ray Tube

The electron-ray tube is an electronic tuning indicator. It consists of a triode tube and, within the same envelope, a funnel-shaped

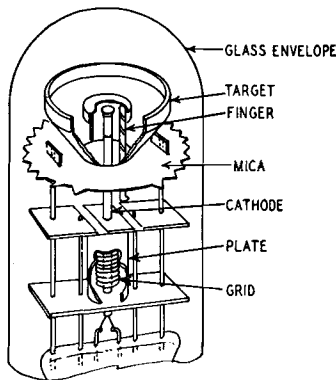

Fig. 2406—An electron-ray tube structure.

“target,” coated with fluorescent material that glows whenever and wherever electrons strike it. Fig. 2406 is a simplified drawing of this

construction. Fig. 2407 shows the circuit of the electron-ray indicator. The target has about 250 volts applied to it and attracts many electrons from the cathode. The plate of the triode is fed from the target voltage through a 1-megohm resistor, so the actual plate voltage varies with the plate current. This plate current is controlled by the a.v.c. voltage, to which the triode grid is connected.

As shown in Fig. 2406, a little "finger" is attached to the triode plate, and is located between the cathode and target. When the voltage on the plate—and consequently on the finger—is less than the target voltage, the comparatively negative voltage develops an electrostatic field about the finger that shields a portion of the target from the electron stream and so produces a wedge-shaped shadow on the glowing circular target face. When the a.v.c. voltage increases as a

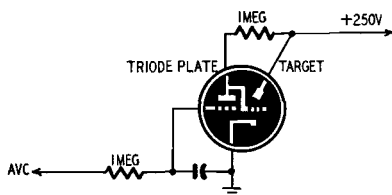

Fig. 2407—Circuit for the indicator tube.

station is tuned in, the plate current of the tuning-eye triode decreases, and the triode plate voltage approaches nearer the target voltage. This means that the interfering field about the finger grows weaker, and the shadow becomes narrower. Tune for the narrowest shadow, and the receiver is correctly tuned.

Tuning Indicator Faults

The tuning indicator of Fig. 2407 is a radio tube and is plagued by the ills common to radio tubes, plus a few of its own. The voltage applied to the target and to the triode plate must be reasonably correct. The resistor which connects the triode plate to the target should be the value specified by the manufacturer of the particular indicator tube. If this resistor becomes too high in value, the voltage applied to the ray-control electrode (the ray-control electrode is internally connected to the triode plate) will become excessively positive and the shadow will not only close, but the glowing segments will actually overlap, making exact tuning difficult. Excessive a.v.c. voltage will cause the same trouble. If the tube works properly, but the glow is weak (and all potentials are normal) the tube may be considered defective.

Automatic Tuning

Down through the years the radio engineers have been guilty of contributing to the laziness of the radio user. When the radio owner complained about having to tune three separate dials, the engineers gave him single-dial control; when the owner, with tin ear, was unable to tune his receiver properly by the sound of it, the engineers provided him with a tuning indicator that he could watch. But still he was not satisfied; he still had to turn that one knob and

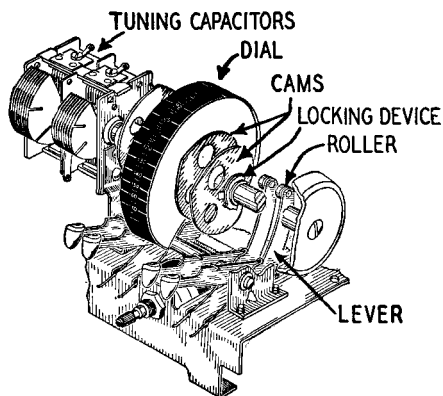

Fig. 2408—One type of arrangement that is used for mechanical push-button tuning.

watch that tuning indicator. That was too much work, he said. The radio engineers reached for their slip-sticks and came up with automatic tuning. Then all the customer had to do was to push a button and the receiver was automatically tuned to the station he wanted.

There are many methods of automatic tuning, but all may be labeled either mechanical or electrical. The mechanical system is represented in Fig. 2408. The shaft of the tuning capacitor has heart-shaped cams mounted on it. The cams are loose but can be locked in any desired position. Associated with each cam is a lever that forces a roller against the edge of the cam and pushes directly toward the shaft. Under this condition the cam and tuning capacitor shaft rotate until the roller comes to rest in the V of the cam. By positioning the cam on the shaft so that this "at rest" position tunes in a station, that station can always be tuned in simply by shoving the lever that works the cam. As many stations can be set up for automatic tuning as there are cams.

Receivers which use automatic tuning ordinarily have some provision for manual tuning, so that the option of using automatic or manual tuning remains with the set user.

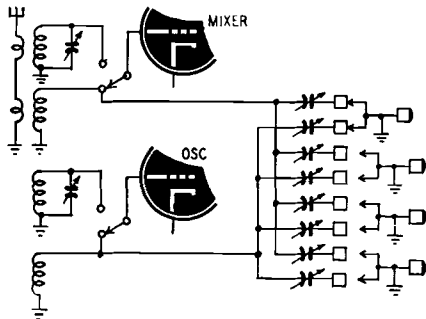

Fig. 2409—A circuit for electrical push-button tuning. Each button connects a pair of capacitors to the tuning coil.

All-electric push-button tuning is popular. In one version, the coil-and-variable-capacitor combinations that tune the oscillator and

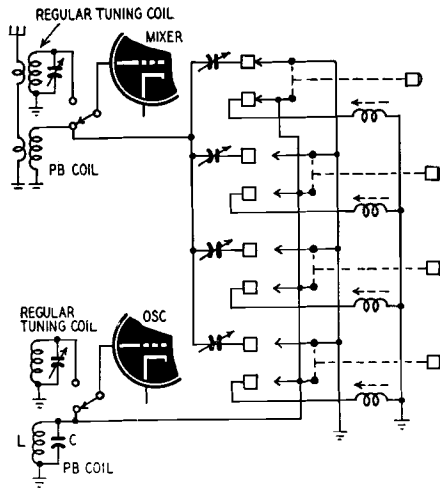

Fig. 2410—Another type of push-button tuner circuit. This one switches slug-tuned coils across the oscillator coil.

input circuits are switched out of the circuit and are replaced by coils tuned by pairs of semivariable capacitors, any one of which may be connected across the respective coils by push buttons, as shown

in Fig. 2409. Each push button connects a different capacitor across the oscillator coil secondary and another across the antenna coil secondary. By preadjusting each pair of capacitors to tune in a particular station, the push buttons can be used to select those stations at will.

Slug-Tuned Tuner

A variation of this method is diagrammed in Fig. 2410 and is shown in the photo, Fig. 2411. The difference lies in the fact that slug-tuned coils are switched across a fixed-tuned circuit in the oscillator section to adjust the oscillator to different frequencies. At the same time, preset semivariable capacitors are switched across the input secondary as was the case in Fig. 2409. The claimed advantage of this system is that the slug-tuned coils are a little more stable than the semi-

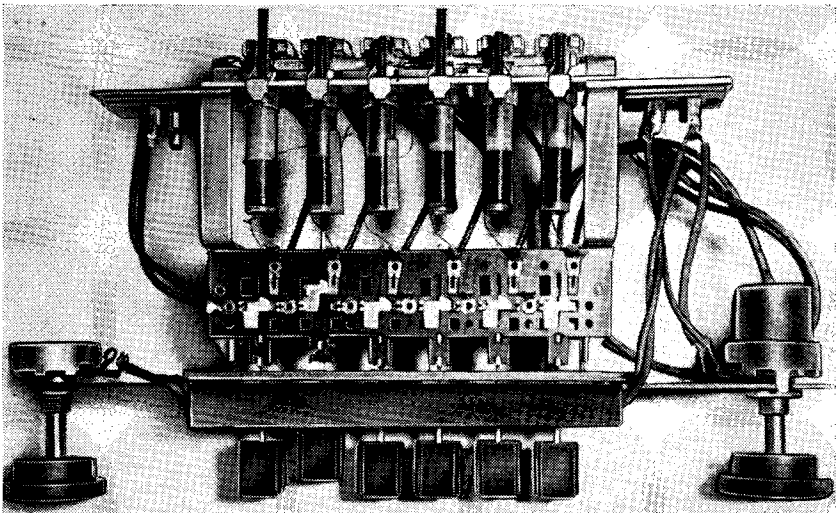

Fig. 2411—A push-button tuning assembly such as the one diagrammed in Fig. 2410. The treble and bass tone controls are mounted on the push-button assembly.

variable capacitors used to tune the critical oscillator frequency in Fig. 2409. Since inductances in parallel have less inductance than either of the branches, it is easy to see why paralleling the fixed-tuned circuit of L and C that is resonant below the broadcast band, with adjustable inductances, will permit the oscillator to be set to any desired frequency necessary to tune a broadcast station.

We have barely scraped the surface of the subject of automatic tuning systems. For an exhaustive discussion of the subject, the writer recommends the *Technical Manual*, published by P. R. Mallory and Company of Indianapolis.

Tone Controls

The simplest tone control is a capacitor in series with a variable resistor. The capacitor lets higher frequencies pass more easily, and the resistor controls the amount of the highs that are passed. If this combination is connected between signal and ground, more low frequencies than highs reach the speaker, and low notes seem stronger.

More elaborate tone controls use a stage that will amplify the low or the high frequencies, but not sounds in the middle range. By making the gain of such stages variable at both ends of the audio spectrum, we get a neat way of controlling the sound.

RADIO servicing equipment falls into two classifications: trouble-locating tools and trouble-repairing tools. First consider those used to find the causes of receiver failure. These trouble-detecting devices are essentially "electronic"; that is, they are actuated by or produce voltages and currents that are, in turn, manifestations of electron behavior.

A Versatile Instrument

The old standby of the technician is the volt-ohm-milliammeter abbreviated v.o.m. This instrument is a low-current meter that can be switched into suitable circuits for measuring alternating or direct voltages, direct current, or resistance. Various ranges are ordinarily provided. For example, a typical v.o.m. has the following ranges for indicating d.c. milliamperes, d.c. volts, or a.c. volts: 0 to 5, 25, 125, 250, 500, 1,250. The ohms scale run: 0 to 2,000, 20,000, 200,000, 2,000,000 and 20,000,000.

A choice of several ranges is an aid to accuracy. Service instruments are usually rated at an accuracy of 2% of the full-scale reading. That means the permissible error on the 1,250-volt scale is 25 volts; but on the 125-volt scale is only 2.5 volts. To insure accuracy, the value being read should be at least 50% of the full-scale reading of the meter. This can be arranged with a wide variety of values to be measured, by having several meter ranges available.

Fig. 2501 shows the basic circuits of a d.c. milliammeter, a d.c. voltmeter, an a.c. voltmeter, and a d.c. ohmmeter, respectively. The meter itself (M in the diagrams) is a d.c. meter with a sensitivity such that 1 ma of current will make it read full-scale.

In Fig. 2501-a, all the current passing through the probes must also pass through the meter. The maximum current that can be measured is that of the meter rating. It is possible, as indicated, to switch *shunt* resistors across the meter so that the probe current can

divide, part going through the shunt resistor and part through the meter. By proportioning the resistance of the shunt to that of the meter, we can allow any desired fraction of the total current to flow through the meter.

For example, if our meter has a resistance of 45 ohms and the shunt has a resistance of 5 ohms, 9/10 of the probe current will go through the shunt and 1/10 through the milliammeter. Every reading on our shunted meter scale now indicates exactly 10 times the amount of current flowing in the probes. We can arrange a new scale to show this amount with shunts of decreasing resistance, the meter indicating increasing ranges of current.

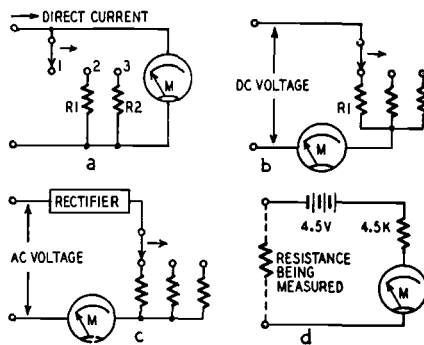

Fig. 2501—The four basic v.o.m. circuits.

In the voltmeter circuit of 2501-b, suppose R1 is 5,000 ohms. Neglecting the small resistance of the meter, 5 volts across the probes will send 1 ma of current through the meter, 2.5 volts will send 0.5 ma, etc. The current through the meter varies directly with the voltage across the probes. If we increase the value of the series resistance to 50,000 ohms, 50 volts will be needed to make 1 ma of current go through the meter. All we need do is make a new scale in which meter current is translated into volts-across-the-probes, and we have a *voltmeter*. Increasing the range of the voltmeter is simply a matter of increasing the value of series resistance.

Measuring a.c. looks as though it might present a problem (since our meter will react only to d.c.) but it really isn't. We put in a rectifier; it jerks the zig-zag out of the a.c. and makes it over into d.c. that our meter can handle. By employing proper values of resistance in Fig. 2501-c, our current-reading meter can be made to indicate the r.m.s. value of an a.c. voltage across the tests prods.

Fig. 2501-d is a simplified ohmmeter. It consists of a battery, a fixed resistance, our meter, and a pair of test prods all in series. Suppose our battery is 4.5 volts and the resistor is 4,500 ohms. When

our prods are shorted together the battery sends 1 ma of current through the meter, making the pointer swing over to the full-scale mark, which we label "0 ohms." Now, if we place a resistor between the probes, the current will be reduced and our pointer will not swing so far. The meter scale can be marked so that the pointer will indicate the exact value of resistance between the probes. Ohmmeters actually used in v.o.m. circuits are not this simple, but follow the same principle.

A v.o.m. used as a voltmeter has one serious objection: it draws appreciable current from the circuit being tested. Consider the typical screen-supply circuit of Fig. 2502. The screen draws 1.5 ma and is fed through a resistor of 100,000 ohms from a 250-volt source. If we try to measure the screen voltage with our voltmeter, the current used by the meter will have to be added to that already flowing through the dropping resistor. Even if this current is only 0.5 ma, its value added to the 1.5 ma drawn by the screen will reduce the normal screen voltage of 100 to an *indicated voltage* of 50.

Other Trouble Finders

The vacuum-tube voltmeter, abbreviated v.t.v.m., is designed to correct this. Basically, it employs the amplifying properties of a vacuum tube so that the voltage being measured is applied to the grid of a tube with the current-reading meter in the plate circuit. Since no current flows in the grid circuit, no power is absorbed from the circuit being tested, and a more accurate indication of voltage is had. The v.t.v.m. can measure resistance values up to one billion ohms, and it is practically impossible to injure the meter by employing too low a range for measuring a voltage—an easily made mistake that has sent many a v.o.m. to its last windup!

The v.t.v.m. has two main disadvantages—most v.t.v.m.'s will not measure current, and all of them must have their vacuum tubes supplied with power from the power line or from batteries.

The signal generator is another important service instrument. Essentially it is a tiny transmitter that will produce an r.f. signal of any frequency from about 100 kc to 30,000 kc. This signal can be used in its pure r.f. form or with 400-cycle tone modulation, and its strength can be varied from zero to a value stronger than would be put into a receiver by a powerful transmitter. The signal generator can produce the proper signal for exciting any stage of a receiver. It is absolutely necessary for the proper alignment of the i.f. stages of a superheterodyne receiver! A good signal generator is one whose dial readings of frequency are accurate and stable, whose output can be thoroughly controlled, and whose construction is such that it will retain these virtues year after year.

Some radiomen insist that a tube tester is not a service instrument—it is just to sell tubes! They mean that a good technician can quickly

spot an under-par tube by its effect on the receiver itself. While that is partly true, a tube checker often permits the discovery of a bad tube without removing the chassis from the cabinet; furthermore, the public has a childlike faith in tube testers and is suspicious of a service technician without one.

These instruments vary in price and in simplicity of operation. None will do a 100% job of revealing tube shortcomings; but even a low-priced tester will reveal 95% of the bad tubes. Thanks to the stream of tubes hatched up by tube engineers, a tube checker becomes out of date faster than a risqué story at a salesman's convention. That is why many technicians are slow to buy expensive types of testers, preferring to use tube substitution to reveal the few defective tubes that a low-priced tester will not catch.

The most recent electronic bloodhound is the signal tracer. This instrument consists of a high-gain audio amplifier preceded by a probe that contains a detecting device at its business end. This detector may be a vacuum tube or a germanium-crystal, but its purpose is to

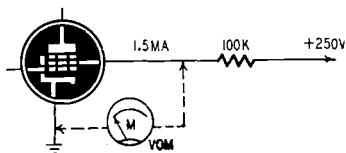

Fig. 2502—The v.o.m. type volt-meter cannot be used in high-resistance circuits.

strip the modulation from any r.f. signal it encounters. The modulation can then be handled by the amplifier and heard in the tracer speaker. With such an instrument a strong modulated signal can be followed stage by stage through the receiver from antenna to speaker. The stage where trouble starts is thus revealed, and then the v.o.m. or v.t.v.m. can take it from there.

Other Tools You Need

The radio technician can never have too many screwdrivers. He needs them in all sizes from the tiny, long-bladed job used to loosen deep-set knob set-screws to the stubby, broad-bitted driver for tightening large chassis bolts. A good mechanic always selects the proper-sized screwdriver for use on a particular screw-head, and he *must* have the proper driver for use on Phillip's screws. He should have a driver with a screw-holding feature for placing screws and bolts in the cramped quarters found in radio work; and he must have several special-insulation aligning screwdrivers for adjusting i. f. and r.f. trimmers.

A good set of hex-nut drivers is another required tool. The walls of the sockets should be thin so that the wrench may be slipped over a nut in a tight spot, and the stems should be hollow so that the wrenches can be used to tighten speaker-holding nuts on the extra-

long bolts that are often used. A set of small end wrenches are fine for adjusting speaker cone spiders and for working in places that will not allow a hex-nut driver to be used. A small adjustable wrench should be available for handling non standard nuts that are encountered in radio work. A 1-inch vice-grip wrench is excellent for this purpose, for it can also serve as a small vise to hold parts together while being soldered.

Every service bench should have a pair of lineman's pliers, needle-nose pliers, flat-nose pliers, ignition pliers, and eyebrow tweezers. Jobs will be found in service work that only one of these tools can do.

What electric clippers are to the barber the electric soldering iron is to the service technician, and he should have good ones. Service technicians today use a solder gun for their work because of such features as being always ready, quick heating, and economical. Every

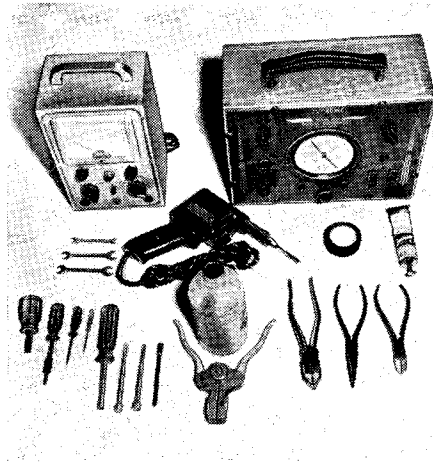

Fig. 2503—Basic equipment needed to begin a radio repair business.

service shop also needs a heavy-duty iron of 200 watts for chassis soldering and for other jobs requiring lots of heat.

There are many miscellaneous tools used in service work: speaker shims for centering speaker voice coils about pole pieces; wire-strippers for quickly removing insulation from wires; a metal saw for cutting volume-control shafts; a pair of good, sharp diagonal cutters that will bite a wire cleanly in two; an electric drill to drill out rivets and make holes in the chassis; carbon tetrachloride for cleaning volume controls, switch contacts, etc.; Duco cement for repairing speaker cones and for fastening coil turns; and acetone for softening this cement when necessary.

If you are going to do auto-radio servicing you will need a way of powering these sets on the bench; either a battery-and-charger combination or a battery substitute powered from the light line. There are such things as capacitor checkers, audio generators, cathode-ray oscilloscopes, etc., that are fine to have and which can be useful after you have acquired enough money to buy them, but you do not need them to start in business. Put the rest of your capital in a good set of service manuals. The manuals will give you more help than a room full of "advanced" servicing instruments when you are starting in business—and for some time thereafter, too.

Fig. 2503 illustrates some of the tools and test instruments used by the service technician. The tool in the center foreground is a wire stripper, while almost immediately behind is a soldering gun. The other tools shown, the screwdrivers, the diagonal cutters and long-nose pliers, the hex-nut drivers and open-end wrenches—these form a *basic* collection of tools. The instrument shown in the upper left can be a vacuum-tube voltmeter, or a volt-ohm-milliammeter. The instrument in the upper right is a signal generator.

“SERVICE technique” is the hoity-toity phrase used to describe something that is as essential to a service technician as a skimpy bathing suit is to a beauty contestant. The service technician may be the best brain in the business, and he may have the most completely equipped shop in these United States; but unless he can actually put those brains and that equipment to work servicing radios speedily and well, he is not going to offer much competition to the other boys in the game. In the words of the song: “It’s what you do with what you got that counts”; and what-you-do-with-what-you-got is just another name for your service technique. It is the *way* you go about locating and repairing receiver faults.

Strictly speaking, the important part of the technique is the procedure employed in trouble-shooting, for locating the trouble is by far the most important work that the technician performs. It is the part of his job that requires the most time, training, and equipment, the part for which the major portion of the service charge is really made. Actual repairing is usually simply a matter of snipping out a defective part and soldering in a new one; but even the best of technicians will occasionally sweat blood determining just which of the vast number of parts in a large receiver needs this replacement treatment.

Trouble-shooting Methods

Down through the years several different systems of trouble-shooting have enjoyed popular favor. Each of these systems is important enough so that every technician should thoroughly understand and be able to practice all of them.

Voltage Measurement

“Voltage measurement” is probably the long-time favorite system with most radiomen. It is based on the assumption that most troubles that afflict a radio—such as open resistors or coils and shorted capaci-

tors—cause changes to occur in the voltages applied to the various tube elements. If the voltages present at the tube sockets are carefully checked against the voltages that *should* be there, any discrepancy will point the finger of guilt directly at the defective part.

Take the example of the single-tube output stage diagrammed in Fig. 2601. All voltages are measured with respect to the ground. A positive voltage on the grid would indicate that C1 was partially shorted or leaky. No voltage on the plate would mean that C2 was shorted or the primary of T1 was open. No voltage on either the plate or screen would mean that C4 was shorted or that there was some trouble in the B-plus supply. If the cathode voltage is exceptionally high, R3 must be open; if too low, C3 is probably shorted, etc.

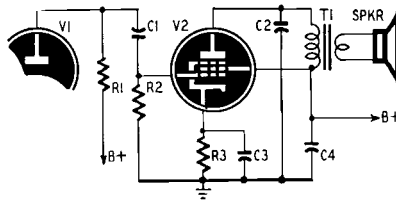

Fig. 2601—A single-tube output circuit.

One trouble with this system is that the user must know what voltages should be present on each tube element. A general idea may be obtained from the recommended voltages given in a tube manual; but a much better source of this information is a voltage chart prepared either by the manufacturer or by the publisher of service manuals. Of course, after years of experience, the technician learns to know what voltages may be reasonably expected at the tube sockets of simple receivers; but even the experienced technician prefers to work from a service manual in performing his voltage measurements. The voltage measurement system at work is illustrated in Fig. 2602.

Another objection to the voltage measuring system is that the set must be turned on while the checks are made. That means if there is a serious short in the receiver, some component may be overheating during this time.

Resistance Measurement

“Resistance measurement” overcomes this last objection, for it can be carried on while the set is unplugged from the line. It assumes that most radio troubles upset the resistance values normally present between each socket lug and the ground or from one socket lug to another. For example, referring again to Fig. 2601, if C1 is shorted, an ohmmeter will quickly reveal it when a check is made from the plate of

V1 to the grid of V2. A very low resistance from plate to ground means that C2 is shorted; and a zero resistance from screen to ground indicates that C4 is ditto. Infinite resistance between plate and screen points to the primary of T1 being open. A resistance check from cathode to ground will instantly show if R3 is open or if R3 is shorted.

Service manuals indicate the normal resistance from each tube pin to ground in the same way that they give the proper voltage at each socket connection. The service manual is even more important in resistance measurement than it is in voltage measurement, because the tube manual cannot help here. Both of these methods fall down completely when it comes to showing up such defects as "open" capacitors that produce no change in resistance or voltage.

Circuit Disturbance Testing

One of the oldest methods of trouble-shooting is now dignified by the name of "circuit disturbance testing." We used to call it simply "touching the grid caps or pulling the tubes." In this system the grids of the tubes were touched with a metallic object, such as a screw-driver blade, or a tube was pulled from its socket while the radio was turned on. If the portion of the receiver between that particular tube and the speaker was functioning normally, a loud "click" would be heard whenever the plate circuit was broken by removing the tube; or, if the tube was amplifying normally, by the surge sent through the tube by disturbing the grid circuit. By starting at the output stage and proceeding toward the antenna end of the set and noting at just which stage no click could be heard, a fairly good idea was obtained as to where the trouble was. The voltage measurement or the resistance measurement system could be brought into play to pin-point the defect.

While this method is fast and simple and requires no extra equipment, it has a number of disadvantages. For one thing, most modern tubes are of the single-ended type with the grids beneath the chassis; and it is much more difficult to reach them there than it was when they were at the top of the tube. Then, too, the system is not very practical with a.c.-d.c. sets that have all of the tube filaments connected in series. Removing any tube in such a set will usually cause a click in the speaker, since removing a tube is equivalent to turning off the set. Another disadvantage is that this method gives only a very rough idea of where the trouble is. You still have to use another method to run down the defective part.

Signal Injection System

An improvement on the rather crude circuit disturbance method is the "signal injection" system. In this procedure, a signal of the proper nature is placed upon each grid, starting at the output stage and moving toward the front of the receiver. For example, a 400-cycle note

from a signal generator is used on the grids of the audio stages, the i.f. frequency is used on the intermediate stages, and the frequency to which the receiver is tuned is presented to the r.f. and mixer grids.

By noting just where the signal ceases to pass through the set or where it becomes distorted, the operator can determine rather closely where the trouble is lurking. Again, though, the final finger-pointing has to be performed by the voltmeter or ohmmeter. However, this system would have revealed if C1 of Fig. 2601 was open. In that case, when the signal generator was placed on the grid side of the capacitor,

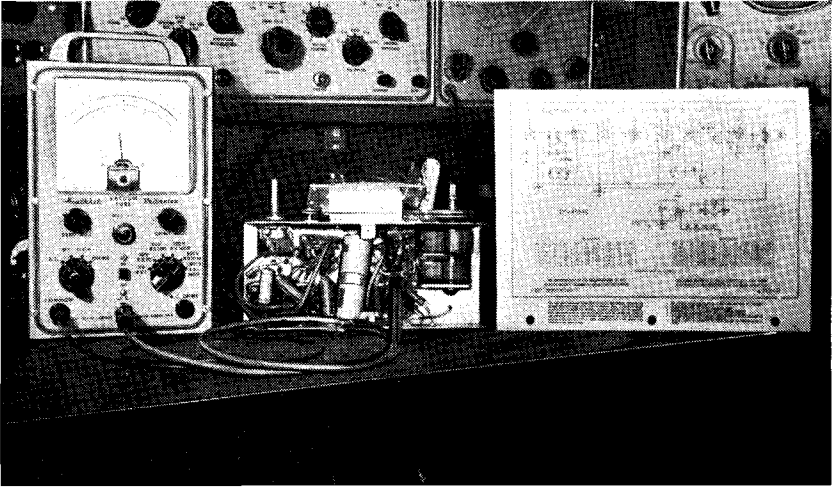

Fig. 2602—The voltage measurement system at work. Readings obtained on the v.t.v.m. are compared with the normal values which are given in the service manual sheet.

the signal would have gone on through to the speaker; but when it was placed on the plate side, no signal would have been heard.

A Newer Method

The most recent method to enjoy popular favor is the “signal tracing” system. This method uses some form of detector—vacuum tube or crystal—mounted in the end of a probe which is connected to a high-gain audio amplifier. When this probe is touched to a point at which there is even a small amount of modulated r.f. energy, the modulation is detected and can be heard in the speaker of the signal-tracer amplifier. Provision is made so that plain audio frequencies can also be picked up by the probe.

The usual procedure in using the signal tracer is to feed a fairly strong modulated signal into the antenna of a receiver, either from a signal generator or from a strong local broadcast station, and then to

trace the passage of this signal, step by step, down through the receiver until it suddenly disappears. By touching the probe first to the grid and then to the plate of a particular stage, not only will the presence or absence of the signal be noted, but also the actual amplification of the tube is revealed, both by the increase in signal as heard in the speaker and by the indication on a signal-strength meter that is built into many of the signal tracers. Furthermore, any noise or distortion originating in that particular stage instantly shows up.

While this system requires a special instrument, the writer strongly favors its use, especially by the beginning service technician. After you are experienced, you will be able, nine times out of ten, to make a very shrewd guess as to what is wrong with a receiver simply by listening to it; and then you can quickly double-check your suspicions by making only a few voltage or resistance checks. Until you get this experience, though, about all you can do with either of the first two methods discussed is to go doggedly through the set, measuring every socket connection until you find something wrong. That is a discouraging and time-consuming business. It is much better to use a signal tracer to point out the particular stage in which the trouble starts and then use your voltmeter or ohmmeter to close in on the actual culprit. Even after you become a hot-shot technician, you will still find your signal tracer indispensable for running down noise, clearing up distortion, etc.

Use All Methods

The good technician should regard trouble-shooting systems in the same way a gay bachelor feels about his feminine friends: he is familiar with all, but married to none. Any one of the systems, if followed persistently and exclusively, in the end will usually turn up a receiver fault; but the same thing can be done much more quickly and easily by using first one system and then another as convenience and the information at hand would seem to indicate.

Let us take a single example: Suppose you are using signal tracing and have followed the signal right up to the grid of the output tube of Fig. 2601 but do not hear any signal at the plate. Next you check the plate voltage and find there is none. This could be caused by either a shorted C2 or an open primary of T1; so next you check the resistance from plate to ground. If C2 is at fault, this resistance will be zero. If the primary is bad, the resistance shown will be infinite. In the latter event, a final "clincher" check can be made from plate to screen.

Had you stuck to voltage or resistance measurement exclusively, you might have checked every other socket connection in the set before finally stumbling on the plate of the output tube; but by using the signal tracer you were able to narrow your search down to this one stage in a few seconds. Then, by resorting to the other two trouble-shooting methods, you were able to decide, by making only two or

three measurements, exactly what part needed replacing.

That is good servicing, for every measurement was made with a definite purpose in mind and was the direct outgrowth of a previous test. A good technician does little haphazard measuring. He realizes that the real trouble-shooting is actually done in the mind, and he uses his instruments merely to feed information and clues to his intellect. Instead of dabbing his test prods here and there without rhyme or reasons, he spends a lot of time studying the circuit diagram, trying to match the symptoms exhibited by the receiver to possible component failures; and then he uses his instruments to prove or disprove his studied guesses as to likely causes of the difficulty.

Screwdriver Mechanics

Every now and then you will run across a radio technician whose boast is of the number of tools and test equipment he does *not* have. He will confidently tell you of the hundreds of sets he has fixed with a wet fingertip or an old screwdriver. He will conveniently forget to tell you about all the receivers he cannot fix, or the total number of call backs by irate customers.

On the other hand you will find the service technician who is instrument happy. His bench is so cluttered with every variety of service instrument that he has no room for repair work.

These two types are extremes. The first one tries to do all his servicing in his head to the complete exclusion of all test instruments. He does not realize that test equipment can either confirm a mental diagnosis, or reveal the trouble where mental gymnastics are just not enough. The second type of service technician believes that his test instruments can do his thinking for him—and that if he gets enough pieces of test equipment he will not have to do any thinking at all.

Fortunately, most successful service technicians steer a middle course. They realize that test instruments are essential—but so is a modest amount of thinking.

I confess it seems a dirty trick that *now* I tell you that you have to think to fix radios; but I was afraid that if I admitted this discouraging fact right in the beginning, before you learned how painless thinking can be when it is mixed with a little fun, you would quit me cold. However, now that you have waded through everything from Ohm's law to the theory of pentagrid converters, I have not the slightest hesitation in divulging that you will need more brains than solder in service work. If you didn't have those brains, you would never have stuck with this book until the end.

It is my hope that the chief aim of this book has been realized: to explain the basic principles of radio in the down-to-earth language that we ordinary fellows use and understand. While I have done my best to keep the promise that you were to become thoroughly ac-

quainted with the appearance, function, and weaknesses of every component normally found in a radio receiver, the presentation of this material has been deliberately casual and not too serious in tone. The writer has always held with Lin Yutang that, "Seriousness, after all, is only a sign of effort, and effort is a sign of imperfect mastery."

Index...

A-battery	76
A.c.	10, 36
A.c.-D.c. Supply	82
Air Capacitors	30, 31
Air-Core Transformer	49
Alternating Current	10, 36
Ampere	11
Amplification Factor	63, 72
Amplifier, Push-Pull	106
Antenna	140
Antenna Circuit	140
Antenna, Loop	141, 143
Armstrong Oscillator	134
Atoms, Ionized	9
Audio Choke	23
Audio-Frequency	92
Audio-Frequency Amplifier	102
Auto-Radio Power Supply	87
Automatic Tuning	155
Automatic Volume Control	147
A.V.C.	147
A.V.C., Delayed	148
A.V.C. Troubles	148
B-Battery	76
Back EMF	21
Baffle	93
Ballast Resistor	83
Bandwidth	124
Bathub Capacitor	32
Battery Power	76
Beam Tube	69
Beat Frequencies	126
Bias	61, 134
Capacitance	24, 26
Capacitance, Inter-electrode	65
Capacitive Reactance	39
Capacitor:	
Air	30, 31
Bathub	32
Breakdown	29
Ceramic	34
Coefficient, Temperature	34
Dry Electrolytic	32, 33
Input Filter	80
Mica	31
Oil-Filled	32
Padder	136
Paper	31, 32
Plastic-Film	32
Polarization	33
Silver-Mica	31
Temperature Coefficient	34
Carbon Resistor	14
Cascade r.f. Stages	120
Cathode	57
Catwhisker	112
Ceramic Capacitor	34
Characteristic, Mutual	72
Characteristics, Tube	71, 73
Chokes:	
Audio	23
Input-Filter	79
Radio-Frequency	23
Circuit Disturbance Testing	167
Coil, Secondary	49
Colls	19, 23, 49, 134
Conductance	73

Conductors	9
Cone	91
Control Grid	61
Control-Grid-Plate Transconductor	73
ance	73
Converter, Pentagrid	131
Converter Stage	125
Converters	125
Core Laminations	53
Core, Magnetic	20
Cores	53
Coulomb	11
Counter EMF	21, 50
Coupling	49, 122
Critical Coupling	123
Crystal Detector	112
Crystal Germanium	117
Current	11, 12
Current-Inducing Field	139
Current, Magnetizing	51
Current, Plate	57
Cycle	10
D.c.	10
Delayed A.V.C.	148
Demodulation	110
Demodulator	110
Detection	110
Detectors:	
Crystal	112
Diode	113, 114
Grid-Leak	114
Power	116
Dielectric:	
Constant	28
Electrons	27
Material	28
Diode	55
Diode Detector	113, 114
Direct Current	10
Distortion	98, 102
Distortion, Harmonic	107, 108
Driven Oscillator	132
Dry Electrolytic Capacitor	32, 33
Dynamic Characteristics	73
Dynamic Speaker	91
Eddy Currents	52
Electrical Energy	16
Electrical Tuning	155
Electricity:	
Negative	8
Positive	8
Electrolytic Capacitor, Dry	32, 33
Electrolytic Capacitors	32, 33
Electromagnetic Field	18, 19, 139
Electromotive Force	9
Electron Drift	10
Electron-Ray Tube	153
Electrons	8, 66
Electrons, Secondary	66
Electrostatic Field	139
EMF	9, 11
Emission, Secondary	86
Energy, Electrical	16
Fading	146
Farad	26
Feedback	65

Field Coil	82	91	Loudspeaker:	
Field-Coil Dynamic Speaker		92	Cone	91
Field, Electromagnetic	18, 19,	139	Dynamic	91
Field, Electrostatic		139	Permanent-Magnet	92
Filament	57,	60	Spider	91
Filter, Capacitor Input		80	Voice Coil	91, 95
Filter, Choke		23	Voice-Coil Impedance	95
Filter, Choke Input		79	Low-Impedance Loop	141
Filter, Smoothing		79		
Fixed Resistors		14		
Flat-Topping		124		
Force, Electromotive		9	μ	63, 72
Frequency	10, 90,		Magnetic Core	20
Frequency, Resonant		43	Magnetic Field	18, 19, 139
Full-Wave Rectifier		78	Magnetic Intensity	21
Fundamental Wave		108	Magnetic Polarity	18
			Magnetic Strength	20
			Magnetizing Current	51
Gassy Tubes		59	Maximum Power Transfer	98
Germanium Crystal		117	Mechanical Tuning	155
Gm		73	Megohm	11
Grid		61	Meissner Oscillator	134
Grid, Control		61	μf	26
Grid-Leak Bias		134	Mho	73
Grid-Leak Detector		114	Mica Capacitor	31
Grid-Plate Capacitance		65	Microfarad	26
Ground		150	Microhenry	23
Ground Waves		144	Micromho	73
			Micromicrofarad	26
Half-Wave Rectifier		77	Microphonic Tubes	59
Harmonic Distortion	107,	108	Milliampere	11
Harmonics	107,	108	Millihenry	23
Hartley Oscillator		134	Mixer	125
Heat		16	μH	26
Heat Losses		16	Modulation	110
Henry		23	Mu	63, 72
High-Impedance Loop Antenna	141,	143	Multiple-Winding Transformers	54
Horizontal Polarization		140	Mutual Characteristic	72
Hysteresis		52	Mutual Conductance	73
I. f.		122	Negative Electricity	8
I. f. Defects		124	Negative Ion	9
Image Rejection		130	Nichrome Resistor	14
Impedance	35,	41	Noisy Tubes	59
Impedance Match		101	Non-Synchronous Power Supply	87
Impedance, Primary		100		
Impedance Ratio		100		
Impedance, Secondary		100	Ohm	11
Indicator, Tuning		152	Ohm's Law	12
Indirectly Heated Cathode		57	Oil-Filled Capacitor	32
Induced EMF		20	Oscillator:	
Inductance		23	Armstrong	134
Induction	18, 19,		Circuits	132
Inductive Reactance		40	Driven	132
Inductors	19, 23,		Hartley	134
Instruments		159	Meissner	134
Insulators		9	Tracking	136
Intensity		90	Troubles	138
Intensity, Magnetic		21	Output Stage	95
Inter-electrode Capacitance		65	Output Transformer	99, 100
Intermediate Frequency		122	Overloading	106
Ion		9	Oxide-Coated Filament	60
Ionized Atoms		9		
Ionsphere		145	Padder Capacitor	136
Iron Core		20	Paper Capacitor	31, 32
			Parallel Circuit	42, 45
K		28	Parallel Trap	47
Kinetic Energy		56	Pentagrid Converter	131
Kirchoff's Law		13	Pentode	66, 68
			Permanent-Magnet Speaker	92
Lagging Phase		38	Phase	35, 38
Laminated Core		53	Phase Inversion	104
Laminations		53	Phase Shift	37
Leading Phase		38	Pitch	90
Left-Hand Rule		19	Plastic-Film Capacitor	32
Lenz's Law		51	Plate Current	57
Load Line		74	Plate Family	72
Loaded Circuits	47,	124	Plate Load	63
Loading Coil		142	Plate Resistance	72, 97
Loop Antenna		141	PM Speaker	92
Loose Coupling		123		
Losses, Heat		16		

Polarity, Magnetic	18	Sound	89
Polarization, Horizontal	140	Space Charge	60, 61
Polarization of Capacitors	33	Speakers (see Loudspeaker)	
Polarization of Waves	140	Strength, Magnetic	20
Polarization, Vertical	140	Superheterodyne	121
Pole Piece	91	Suppressor Grid	68
Positive Electricity	8	Synchronous Vibrator	88
Positive Ion	9		
Potentiometer	14	Tapped Transformers	54
Power	16, 51, 98	Temperature Coefficient of Capacitors	34
Power Detector	116	Tetrode	60, 65
Power, Maximum Transfer of	98	Thoriated Filament	60
Power Output Stage	95	Three-Way Supply	85
Power Supply:		Tickler Coil	134
A.c.-d.c.	82	Tone Control	158
Auto-Radio	87	Tools	159
Doublers	86	Tracer, Signal	162
Full-Wave	78	Tracking	120, 136
Half-Wave	77	Transconductance	73
Non-Synchronous	87	Transfer Characteristic	72
Synchronous	88	Transformer:	
Three-Way	85	Air-Core	49
Troubles	81	Iron-Core	20
Types	82	Losses	52
Vibrator	88	Multiple-Winding	5-4
Primary Coil	49	Output	99
Primary Electrons	66	Tapped	54
Primary Impedance	100	Troubles	54
Push-Button Tuning	156	Turns Ratio	50, 100
Push-Pull Amplifier	106	Universal Output	100
Q	45	Trap, Parallel	47
Radio Frequency	120	T.r.f. Amplifier	118
Radio-Frequency Choke	23	Trouble-shooting Methods	165
Radio Waves	139	Tubes:	
Reactance:		Beam	69
Capacitive	39	Bias	61
Inductive	40	Cathode	57
Receiver Refinements	150	Characteristics	71, 73
Receiver Selectivity	118	Converter	125, 131
Rectifiers:		Diode	55
Full-Wave	78	Electron-Ray	153
Half-Wave	77	Filament	57, 60
Selenium	85	Gassy	59
Resistance	11	Grid	61
Resistance Measurement	166	Load	63
Resistance, Plate	72, 97	Microphonic	59
Resistors:		Mixer	125
Ballast	83	Noisy	59
Carbon	14	Pentagrid	131
Fixed	14	Pentode	66, 68
Nichrome	14	Plate Current	57
Wattage Rating	17	Plate Family	72
Resonance	43	Resistance	72, 97
Resonant Circuit	42	Screen Grid	64
Resonant Frequency	43	Secondary Emission	66
R.f.	120	Suppressor Grid	68
R.f. Choke	23	Tetrode	60, 65
Rheostat	14	Transconductance	73
Screen-Grid Tube	64	Transfer Characteristic	72
Secondary Coil	49	Triode	60
Secondary Electrons	66	Types	70
Secondary Emission	66	Tuned Circuits	42
Secondary Impedance	100	Tuned-Radio-Frequency Amplifier	118
Selective Fading	146	Tungsten Filament	60
Selectivity, Receiver	118	Tuning	48
Selenium Rectifier	85	Tuning, Automatic	155
Self-Induction	21	Tuning, Electrical	155
Series Circuit	42	Tuning Indicator Faults	154
Series Trap	47	Tuning Indicators	152
Service Techniques	165	Tuning, Mechanical	155
Sidebands	124	Tuning, Push-Button	156
Signal Injection System	167	Turns Ratio	50, 100
Signal Tracer	162	Universal Output Transformer	100
Silver-Mica Capacitor	31	Vacuum-Tube:	
Sky Wave	144	Characteristics	71, 73
Slug-Tuned Circuits	48	Oscillators	133
Smoothing Filters	79	Voltmeter	161

Variable Resistors	14	Volume Control, Automatic.....	147
Vertical Polarization	140	V.O.M.	159
Vibrator	88	V.T.V.M.	161
Voice Coil	91, 95	Watt	16
Voice-Coil Impedance	95	Waves:	
Volt	11	Horizontal Polarization	140
Voltage Amplifier	102	Radio	139
Voltage Doubler	86	Sky	144
Voltage Field	139	Vertical Polarization	140
Voltage Gain	75	Wet-Electrolytic Capacitors	32
Voltage Measurement	165	Wire-Wound Resistor	14
Volt-Ohm-Milliammeter	159		
Volume Control	14		