

PRICE



MODERN RADIO



THE LISTENER IN
Handbook No. 11.

RADIO SET BUILDERS' HANDBOOK



ALL MAKES OF "B" BATTERIES LOOK MUCH THE SAME

WHY THE DIFFERENCE IN SERVICE ?

The usual "B" Battery Works like a Sunset



They start off radiating "spark" and power.

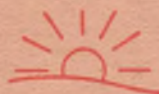

But their power quickly wanes.

And far too soon their power is gone. They're flat!



It's "high noon" for a long, long time with DIAMOND P.5's



"DIAMOND P.5's hold their life and "spark" when others are "setting."



And right down to the end of their long service they have almost as much "spark" as when first installed.

IT'S THE "LASTING" SPARK THAT COUNTS



THE REASON?

The "P.5's" unique construction insures an uninterrupted flow of "sparkling-current" even when the Battery has seen long use. It's a physical fact that "Diamond" remain "healthy" right down to old age. Their system never becomes choked with devitalising elements causing premature decay. The Diamond Company has invested thousands of pounds and years of research to give the Public the advantage of this extra process.

THE PROOF?

The uniformly "longer" life of Diamond P.5's — and this test! Instal "P.5's" in your set. Weeks—months—later—see if your ear can detect any of the usual distortion and crackle—any material falling off in Power. You will find the "P.5" "Vital-Spark" still there, ready to drive your set long after you would normally expect to make replacement.

DIAMOND



Radio Batteries and Torch Refills

STILL KEEP WORKING WHEN OTHERS HAVE STOPPED

WIDDIS DIAMOND DRY CELLS PTY. LTD. 119 Hawke St., West Melbourne, C.3, Vic., F 1175

Thomas Force

American

MICROPHONES



SINGLE BUTTON CARBON

Designed for home broadcasting experimental work, home recording, sports announcements, speakers' platform, class rooms. Models—Lapel-De Luxe lapel—hand with switch—39/6 to £5/15/. Matching transformers extra

CARBON GRANULES—Each vial packs standard 2 button microphone, 9/- per vial.

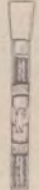

CRYSTAL AND ELECTROSTATIC

A.G. crystal is a diaphragm crystal type of dependable quality. Equipped with chromium plated yoke for various stand mountings and eight feet of low loss cable. Suitable for disc and 16 m.m. film recordings, public address. A general purpose microphone with a wide range of efficiency. Self energizing, no polarizing voltage required. £7/15/ to £9.



G.A. Electrostatic. No inherent noise. High impedance direct to grid, no matching transformer required. £7/10/.

DOUBLE BUTTON CARBON

Designed for amateur transmitters, home broadcasting, public address, experimental recordings, broadcast stations, disc and film recording announcer's booth, voice and orchestra auditions, electrical transcriptions, audition studios. 49/6 to £15/10/. Matching transformers extra.



SUPREME METER KIT

Comprises 5in. fan shaped meter with all necessary shunts and resistors to give readings of 0-5-125 D.C. milliamps — 0-5-125-500-1250 A.C. and D.C. volts — 0-2,000-20,000-2,000,000 ohms. All readings shown direct on meter — Construct your own laboratory meter using Supreme — the famous American meter kit.



CONSOLIDATED ALL-WAVE ANTENNA SYSTEMS

Universal All Wave Antenna, with balanced transmission. Provides complete equipment for erection of antenna, of doublet, and other types, includes aerial transmission cable—Antennatrol—porc' junction block—glass insulators—6in bakelite screw eyes—doublet arrestor—lead-in strip—ground clamp. Includes the improved ANTENNATROL. With the use of this unit the energy transfer is increased to a marvellous degree. With its use receivers should double their receptive powers, bringing in stations formerly overlooked.

Mod. 615 with twisted transmission cable 29/6
Mod. 616, with transposition blocks 39/6



A. G. HEALING LTD.

167 FRANKLIN STREET, MELBOURNE
Manufacturers Healing Golden Voiced Radio.*

HEALINGS Pty. Ltd.

KIT SPECIALISTS

Healings will be pleased to quote for any special Coils or Kits. All Healing Kits are matched with the famous Supreme Oscillator.

RADIOKES KIT SETS

6-Valve Dual Wave Transocean Kit Set

The Transocean 6-valve Kitset uses the new high gain Metal Type Valves, pi wound high selectivity tuning coils, Iron cored I.F.'s, A.V.C. Uses the special World Range edge Light Dial, tuning from 16-50—200. 550 metres. This Kit is an ideal one for the Home-builder. Write us for free simplified instruction sheet on the Transocean Kit.

£11/17/6

WRITE HEALING'S FOR SPECIAL OFFER

38/- ROLA

PERMAG SPEAKER 27/6

Genuine Rola 6 3/4 in. Dustproof Permagnetic Speakers. Were 38/. Now 27/6 ea.

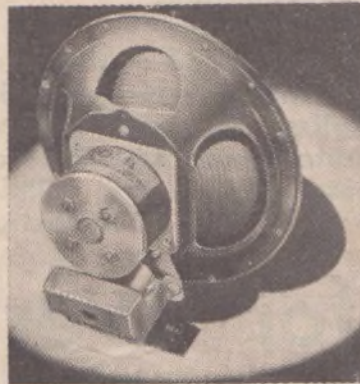

MAIL ORDERS

Healings Mail Order Service is fast and efficient. Country and interstate clients address all orders and enquiries to Mail Order Department.

HEALINGS PTY. LTD.

261 Swanston St. Melbourne

Radiokes Simplified Money Saver Kit

In designing this kit Radiokes main objective was to design a kit that was extremely simple to construct, cheap in price, with good performance and tone. The circuit is similar to that used in the average 5-valve set on the market. An added advantage is that, by purchasing a Radiokes 5-44 all-wave box, with no other extra expense the set can be converted for all-wave reception.

£6/6/-

CHASSIS DIMENSIONS:
12in. x 8in. x 8in.

Acrovision dial.
Pick-up terminals.
Adaptability to all wave.
Diode detection.

FEATURES:

Pentagrid converter.
465 k.c. I.F. amplification.

VALVES REQUIRED:
1/6A7, 1/6D6, 1/75, 1/42,
1/80.

Write for Healing's Special Offer and Free Illustrated Pamphlet

PLANET POWER TRANSFORMER

The Planet M3 Power transformer is specially manufactured by the well-known Radiokes Co. for Healings Pty. Ltd. Never before have quality transformers been offered to the public at such a low figure. Early ordering is advisable, as this offer cannot be continued indefinitely.

M.60 MILLS 7/6
6-3 or 2-5 Volts
385 Volts (F)

M.80 MILLS 9/11
6-3 or 2-5 Volts
385 Volts ea. (x)

HEALINGS PTY. LTD.

261-3 SWANSTON STREET

Phone. C 2064 (2 Lines)

Yet Another MULLARD SUCCESS

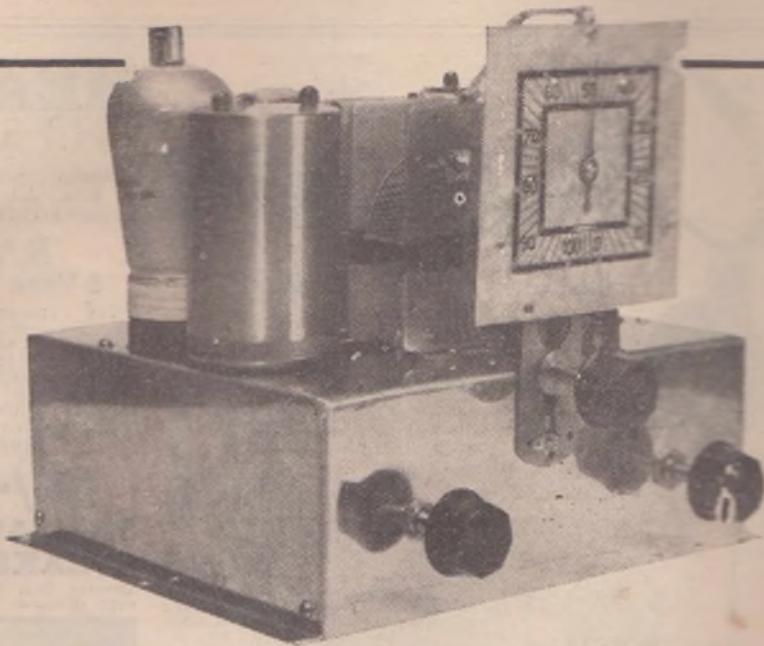

Again, Mullard — the Master Valve — makes possible the sensational battery-operated set described on Page 32 of this issue. The extra power and extreme operating economy of Mullard specially designed valves are a definite adjunct to every radio circuit — so whatever kit you are building choose Mullard valves for super satisfaction.

• "The IRON-CORED Melodious Battery Three"

Complete constructional details of this outstanding circuit are given on Page 32. This specially designed circuit gives amazing performance for such a low-priced kit.

Best for Every Circuit—

There is a complete range of Mullard valves, each and every one specially designed to give trustworthy performance in its special job. Without obligation, Howard Radios (at the address below) will give you every possible assistance and advice to ensure the better service which Mullard valves can give you.

Mullard

MASTER VALVES

Sole Agents for Victoria and Tasmania—

HOWARD RADIO **Pty. Ltd.**

OSBORNE HOUSE, LITTLE COLLINS ST., (next A.G.E.)
Tasmanian Rep. C. C. BOAG, 33 ARGYLE ST., HOBART

CONTENTS

AMPLIFIERS—

High Fidelity Amplifier	Page 48
Compact Audio Amplifier	Page 80

BATTERY RECEIVERS—

Iron Cored Melodious Three	Page 32
Beginner's Battery Super-Het.	Page 59
Countryman's Converter	Page 70

SHORT-WAVE RECEIVERS—

Cruiser S.W. Converter	Page 18
Trans-Ocean Dual-Wave Six	Page 37
All Band S.W. Three	Page 42
Universal Dual-Wave Seven	Page 64
Countryman's Converter	Page 70

SMALL RECEIVERS—

4½ Watt Baby Super	Page 7
Hartwright Crystal Set	Page 17
Cruiser S.W. Converter	Page 18
Mighty Atom	Page 23
Iron Cored Melodious Three	Page 32

SMALL RECEIVERS.—Continued.

All Band S.W. Three	Page 42
Countryman's Converter	Page 70
Supreme T.R.F. Three	Page 76

SUPER-HETERODYNES—

4½ Watt Baby Super	Page 7
1936 Master Five	Page 11
Pre-Selected Universal Super-Het.	Page 27
Trans-Ocean Dual-Wave Six	Page 37
All-Metal Five	Page 54
Beginner's Battery Super-Het.	Page 59
Universal Dual-Wave Seven	Page 64
Exceltone Super 4/5	Page 83

TUNED RADIO FREQUENCY RECEIVERS—

Iron Cored Melodious Three	Page 32
Supreme T.R.F. Three	Page 76

UNIVERSAL RECEIVERS—

Pre-Selected Universal Super-Het.	Page 27
Universal Dual-Wave Seven	Page 64

Make a Receiving Set of Your Pass-Book!

YOUR RECEIVING SET spreads the world at your feet. It regales you with the Witchery of Art in a hundred forms, and lifts you out of yourself.

Your Pass-book may do the same! Build it up by prudent spending and patient thrift and it will repay you a hundredfold in pleasures that will forever remain beyond your reach—unless you save!

Save Systematically — Bank Regularly

STATE SAVINGS BANK OF VICTORIA

THE BEST PLACE FOR YOUR SAVINGS

HEAD OFFICE: 139-153 ELIZABETH STREET, MELBOURNE, C.1.

213 Branches—373 Agencies

ALEX. COOCH, General Manager

Homecrafts Pty. Ltd.

— KIT SPECIALISTS —

Offer special low prices for Kits specified in this issue !



The "Iron-Cored" Melodious Batt. 3

Considered the best Batt. Set yet produced. Featuring latest Iron Core coupling system for greater Selectivity and Sensitivity.

Kit of Specified Parts £5/10/

Including Mullard Valves.

Batts. H.D. Diamond P.5. and Cap. 2 v. 110 amp accumulator **£2/11/6**

Rola PM.5.B. Speaker . . **£1/7/6**

Homecrafts Total Price £9/9/

Write for Free constructional leaflet for further information.

The Hartwright CRYSTAL SET

Simple to build, but extremely efficient in operation. Range up to 75 miles.

Complete Kit of Parts **£1**

Headphones 9/11 extra

Build The "Listener In"

HI-FIDELITY AMPLIFIER

It's Powerful. It's Modern. It delivers 18 Watts output.

Homecrafts Special Price - £15/15/-

Inc. valves, matched Kit of parts, and 10in. Dynamic Speaker.

The "Mighty Atom"

A small AC electric set with tremendous power and range. Its tone is almost faultless. Iron Core Tuning coils, and latest pinless silver Contact, Mullard Valves.

"An entirely new Conception of Receiver Design."

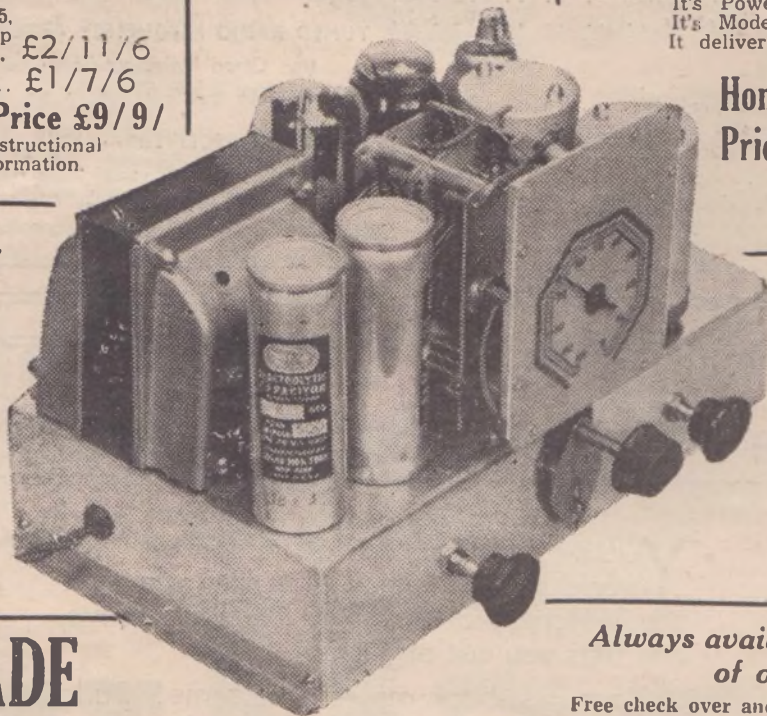

Homecrafts Special Price for Complete Kit including valves and speaker.

£9

RADIO-ADE

Always available to builders of our Kits

Free check over and advice with pleasure.

Beginners' Battery Superhet

A simple and economical 4 V. Battery Superhet. The sensitivity and tone are particularly pleasing.

465 K.C. 9 M.A. "B" current. Homecrafts Special concession total Price for everything. **£11/15/-**

SUPREME T.R.F.3

Special receiver employing metal Valves and Iron Dust Core Coils. for tremendous power and range.

Homecrafts Special Price for Kit, Valves and Speaker. **£10/10/-**

ALL-METAL FIVE SUPERHET.

An ultra modern AC Superhet. employing high selectivity IF's. and all metal Valves

Homecrafts Special complete price with matched Kit. Kenrad Valves and 8 inch Dynamic Speaker. **£12/10/-**

- The Cruiser S.W. Converter 15-100 meters complete with valve . **£6 5 0**
- The Trans Ocean 6 V. Metal Tube Kit, Set complete **£15 15 0**
- The Master Battery Superhet. 5. Complete Kit Set only **£6 0 0**
- The Master AC Super 5. Complete Kit Set **£6 10 6**

Homecrafts

PTY. LTD.

FREE KIT SERVICE and Constructional Booklets
211 Swanston St.

MELBOURNE
Phone C. 8200



Employing the very latest types of valves, this simple super-heterodyne receiver will appeal to both novice and expert.

By A. K. BOX

VALVE manufacturers are concentrating more and more upon the "power-sensitivity" ratings of their output tube.

Quite the best effort to date in this direction has been made by Philips Radio with their new type AL3 pentode. All pentodes have high power-sensitivity rating, but the AL3 is really remarkable, for it delivers an undistorted power output with a signal input of only $3\frac{1}{2}$ watts.

This means that, with a high output crystal type gramophone pick-up, it would be possible to obtain some three to four watts of audio output without the aid

of a pre-amplifier stage between the pick-up and the AL3 pentode.

The valve's advantage is even more evident in radio receiver design, for it is possible entirely to dispense with a driver audio stage between the detector valve and the pentode, and at the same time obtain an increase in the receiver's sensitivity because of the lessened input voltage required for rated power output.

An example of the advantages accruing from the use of the new tube is to be found in the present receiver, which has, aptly enough, been called a "baby super-het."

THE receiver is designed chiefly for local reception, although both its sensitivity and its selectivity warrant the expectation of reception from some of the more powerful interstate broadcasters. Due to the high efficiency of the AL3 pentode, it is possible to dispense with an intermediate frequency amplifying valve, and to employ only three receiving tubes. The first of these is a mixer tube, another new Philips creation, the AK2. This valve is an improved type AK1, the advantages of which are too well known to need re-

petition. The next valve in the receiver is an AF7 radio frequency pentode, another one of the new series tubes. The third is the AL3 output pentode, whilst the fourth is a 1561 rectifier tube. All these valves are provided with the Philips "P" type 8 pin base.

Even allowing for the high detection efficiency of the AF7, and the extraordinary power-sensitivity of the AL3, it is necessary that considerable care be given to the intermediate frequency transformer if a really high degree of sensitivity is to be obtained from the

receiver. There have recently become available in Australia intermediate frequency transformers which use Ferrocart iron cores. The chief advantage of this material is that it raises the efficiency of the tuned circuit, with which it is related, to a very high degree, and at the same time improves their selectivity tremendously. So high, indeed, are the stage gains possible from i.f. amplifiers which employ Ferrocart-cored coils, that considerable pains must be taken to prevent instability so that the true gain of the coils can be realised.

In the present case, however, where no intermediate frequency amplifying stage is used, there is no fear of instability, but the Ferrocart coils DO give us the much-needed gain and selectivity.

Simplicity of Design

Although limited as to the number of tubes the receiver has not been complicated with the components which would be necessary if a dual-purpose tube was used in the second detector stage. A study of the circuit diagram will show that only nine resistors, including the volume control, VC, and the voltage divider, VD, are used in the receiver. Similarly, only 12 condensers, including the padding condenser, PD, and the electrolytic filter condensers, E1 and E2. Such being the case, it can be realised that the receiver is one which the novice can build very easily, and one from which he can expect exceptionally good results.

Glance now at the schematic circuit diagram whilst we run through the salient characteristics of the circuit design. We find the conventional aerial coils consisting of L1 and L2, the latter being tuned by the G1 section of the gang and connecting to the control grid of the AK2 mixer valve, V1. The oscillator grid of this tube is connected to the oscillator grid coil L4 through the small grid condenser C1. The grid leak R1, connected between oscillator grid and cathode of the AK2, serves to bias the former element of the tube. The oscillator plate of the AK2 is fed with a potential of 70 volts as is the screening grid element of the valve. The

condenser C4 acts as a by-pass on the plate coil side of the "B" supply line, whilst C3 performs a similar function for the screening grid supply line.

Bias for the control grid of the AK2 is provided by the voltage drop which takes place across the cathode resistor, R2, which is by-passed by the fixed condenser, C3. For volume control purposes the cathode resistor, R2, is returned to the arm of the volume control potentiometer, VC, which is connected between the 25-volt tap on the voltage divider, VD, and earth. This means, then, that although the required minimum cathode bias of 1.5 volts is always applied to the tube through the medium of the bias resistor, R2, this bias can be increased to the maximum required—25 volts—to give control of over-powerful signals.

The pentode or modulator plate of the AK2 is connected to the primary of the Ferrocart type intermediate frequency transformer. (One supplied by Eclipse Radio was used in the original receiver.) The secondary of IF1 is connected to the control grid of the AF7 radio frequency pentode which is operated as a leaky grid detector by means of the grid-leak, R3, and the grid condenser, C5.

This application of the AF7 was considered desirable because of the greater sensitivity it offers over the more usual

mode bend operation of the second detector tube in a super-heterodyne receiver. The cathode of the AF7 is returned to chassis whilst the screening grid is taken to a 20-volt tap on the voltage divider and by-passed to ground by means of the fixed condenser, C6. In passing, it should be mentioned that this screen grid potential for the AF7 is quite critical as far as the receiver's sensitivity of operation is concerned. Too high a screen voltage will entirely spoil the sensitivity.

High Note Damping

The AF7 is resistance-coupled by means of the plate resistor, R4, the fixed condenser, C7, and the grid resistor, R5, to the control grid of the AL3 pentode. The AF7 is fed with the full supply voltage through this resistor, R4. Bias for the AL3 is obtained by means of the cathode resistor, R6, which has been by-passed by the 25 mfd. electrolytic condenser, C8, to avoid loss of low-frequency amplification.

Connected between the plate and screening grid of the AL3 we find the fixed condenser, C9, in series with the fixed resistor, R7. These two components form the tone compensator circuit the purpose of which is to prevent any over-emphasis of notes of the higher register. The voltage divider, VD, provides a

simple and economical means of obtaining the potentials for the various valve elements. It is connected between the set side of the filter circuit and chassis. The filter circuit is made up of the 2500-ohm field winding of the loud speaker, FC, and the two 8 mfd. electrolytic condensers, E1 and E2. The power transformer, PT, is provided with a centre-tapped winding capable of delivering 400 volts on either side of the grounded point, a 4-volt rectifier filament winding and a 4-volt receiver valve filament winding.

The rectifier used in the original receiver is a 1561 type rectifier, but better results would, we believe, be obtained if an indirectly heated 1867 type tube were used. This is because the latter type tube, in taking as long to warm up as the receiver tubes, prevents excess voltage stresses being placed on the filter condensers E1 and E2.

The next question for consideration is that of the chassis lay-out. The key-lettered illustration of this shows that the AK2 mixer tube is mounted to the left of the gang condenser.

Behind it are mounted the two coil cans; the aerial coil can being the one nearest to the gang condenser. Behind the oscillator coil can is the intermediate frequency transformer, IF1, whilst behind this and in the left-hand rear cor-

SCHEMATIC CIRCUIT DIAGRAM AND PARTS LIST for the "4½ Watt Baby Superhet"

Chassis.—Aluminium, 16 gauge, measuring 13 inches by 9 inches, by 2½ inches.

C1, C5.—.0001 mfd. mica condensers. (T.C.C.)

C2, C3, C4, C6.—.1 mfd. Tubular condensers. (T.C.C.)

C7, C9.—.02 mfd. mica condensers. (T.C.C.)

C8.—25 mfd. 25 volt electrolytic condenser. (T.C.C.)

DS.—Dynamic speaker with 2500 ohm field and input transformer to

match type AL3 tube. (Amplion, Rola).

E1, E2.—8 mfd. 600 volt electrolytic condensers. (T.C.C.)

FC.—2500 ohm loud speaker field winding.

G1, G2.—Two gang tuning condenser to suit coil kit.

IF1.—455 K.C. special Ferrocart type I.F. transformer. (Radiokraft).

L1, L2, L3, L4.—Aerial and oscillator coils—455 k.c.—to match gang condenser.

PT.—Power transformer delivering 100-0-400 v. at 70 m.a., 4v. at 1a., and 4v. at 2a. (Stedi-Power).

P.D.—455 K.C. padding condenser.

R1.—50,000 ohm resistor.

R2.—260 ohm W.W. resistor, 10 m.a.

R3.—1 megohm resistor.

R4.—500,000 ohm resistor.

R5.—250,000 ohm resistor.

R6.—150 ohm W.W. resistor, 50 m.a.

R7.—10,000 ohm resistor.

V.C.—1000 ohm volume control potentiometer.

VD.—25,000 ohm voltage divider. (All I.R.C.)

Valves.—One each types AK2, AF7, AL3 and 1561 with Philips "P" sockets to suit or Mullard replicas.

Sundries.—Machine screws, terminals, I.S. socket, grid clips, hook-up wire, A.C. power plug, tuning dial, knobs, etc.

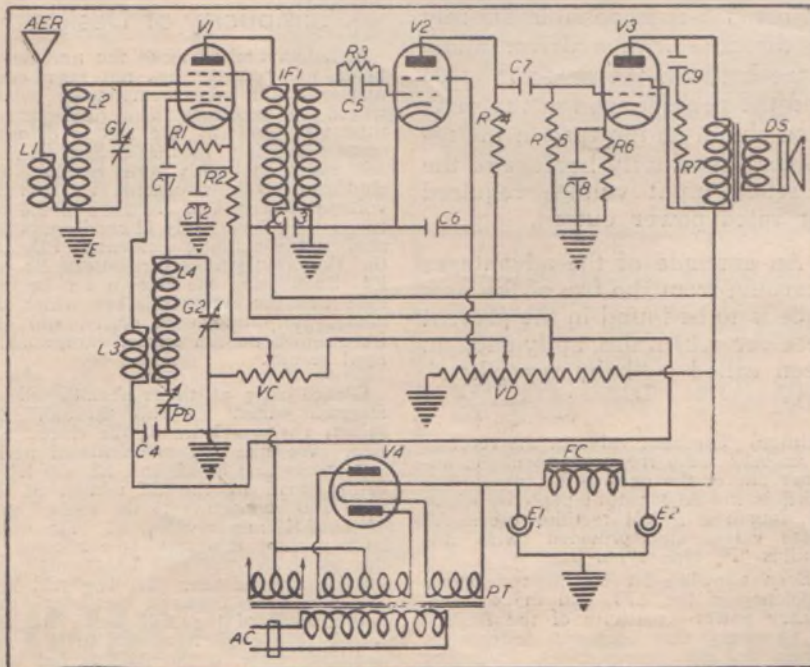

ner of the chassis is the second detector tube AF7. Behind the gang condenser can be seen the two electrolytic filter condensers and in the right-hand rear corner of the chassis are to be found the AL3 pentode and the 1561 rectifier. The rectifier tube is the one nearest to the corner of the chassis. The power transformer PT is mounted in the front right-hand corner of the chassis.

Along the rear of the chassis we find the aerial and earth terminals at the left and the loud speaker socket at the right. The front of the chassis carries two controls, the one actuating the tuning condenser and the shaft of the volume control. The padding condenser, PD, is mounted underneath the chassis in the corner near the AK2. A hole should be drilled in the top of the chassis to permit adjustment of the padding condenser. Underneath the chassis we find that the only component which has to be mounted into position is the voltage divider, VD, which is bolted down near the power transformer, P.T. All other components are soldered directly into circuit.

The chassis itself is made from 16-gauge aluminium and measures 13 inches in length, 9 inches in width and 2½ inches in depth. Assuming that all assembly has been completed, the wiring of the receiver can be started. This part of the job is quite simple and should not take more than an hour.

Point to Point Wiring

BEGIN by running a lead from one of the outside lugs on the 4-volt valve filament winding to one filament lug on the sockets for V1, V2 and V3. Take a similar lead from the other outside lug on this winding to the remaining filament lug on each of the three sockets. Take a lead from one lug on the rectifier filament winding to one filament lug on the rectifier socket, G4. Likewise, connect the remaining lug on the rec-

tifier filament winding to the remaining filament lug on the rectifier socket.

Take one of the outside high voltage lugs on PT to one plate lug on the rectifier socket and join the other plate lug on this socket to the remaining outside high voltage lug on PT. A lead is taken from one filament lug on the socket for V4 to the positive lug on the electrolytic condenser, E1, and to one of the field winding lugs on the I.S. socket. The other field winding lug joins to one of the input transformer

lugs on the same socket, to the screening grid lug on the socket for the AL3 pentode, and to the positive lug on the electrolytic condenser E2. From this point on E2 a lead goes off to the positive end of the voltage divider, VD.

One lead of the 10,000 ohm resistor R7 is soldered to the screening grid lug on the AL3 pentode socket. The other lead on this resistor joins to one lug on the .02mfd. condenser, C9. The remaining lug on C9 joins to the plate lug on the AL3 socket and to the remaining input transformer lug on the I.S. socket.

Now run an earth wire from the centre-tap lugs on each side of the two filament winding to the negative end of the voltage divider VD, thence along the chassis to join with the earth wire extending from the earth terminal to the padding condenser. Join the aerial lead from the aerial coil L1 to the aerial terminal on the chassis and take the earth lead from this coil and the corresponding lead from the grid coil L2 to the earth wire.

The grid end of L2 goes to the fixed plate lug of the G1 section of the gang condenser, and carries another lead, which terminates in the grid clip for the control grid of the AK2. The screening grid lug on the AK2 socket carries one lead of the .1 mfd condenser, C3, the other lead of which is connected to the ground wire. Join the screening grid lug on the A2 socket to the B plus end of the oscillator plate coil, L3. From the same lug on the AK2 socket runs a lead to the 70-volt tap on the voltage divider, VD. The "B" plus end of the plate coil carries one lead of the .1 mfd condenser, C4, the other end of which is earthed. The plate end of the oscillator plate coil joins to the No. 2 grid lug on the AK2 socket. Solder one lug of the .0001 mfd. fixed condenser, C1, to the grid No. 1 lug on the AK2 socket and to one lead of the 50,000-

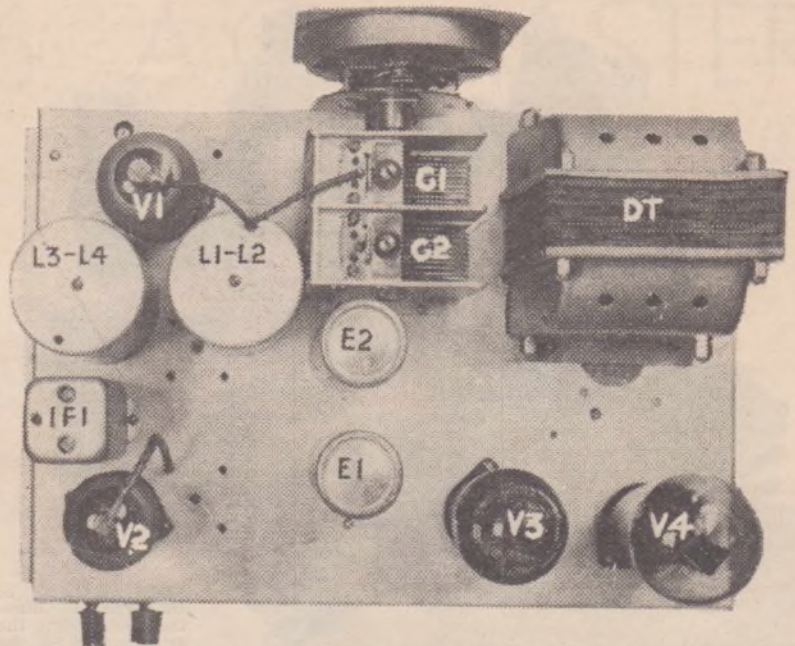

A top plan view of the chassis which has been key-lettered to agree with the parts list and the wiring description.

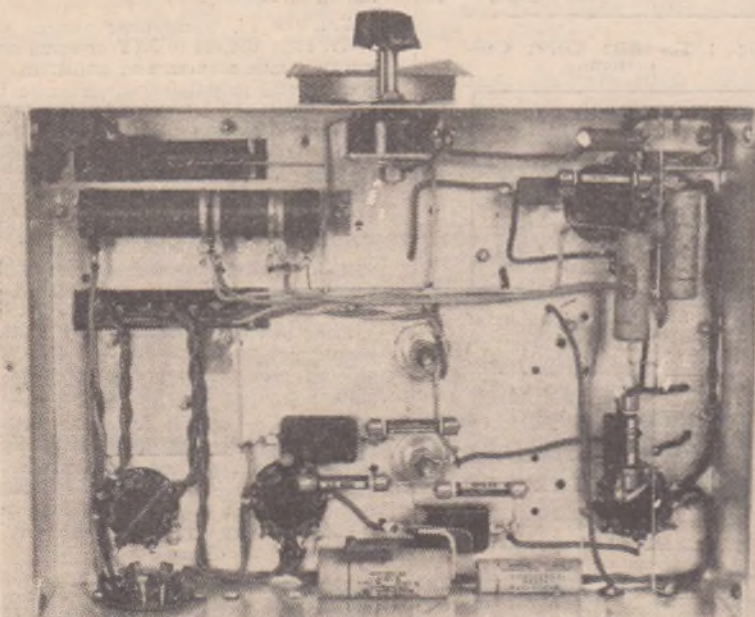

This under-chassis view of the original receiver shows clearly that very few components are required for its construction.

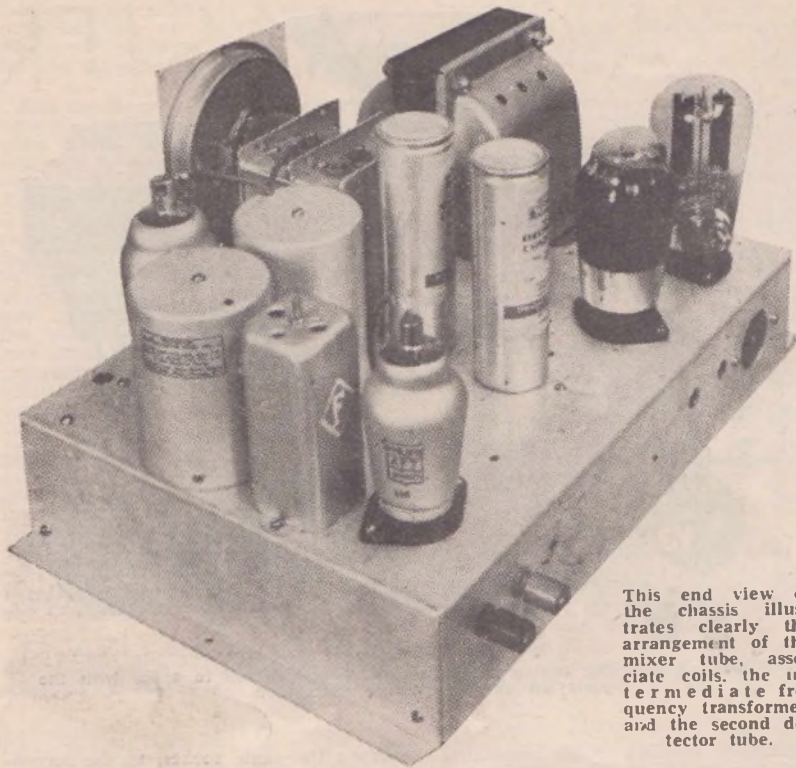

This end view of the chassis illustrates clearly the arrangement of the mixer tube, associate coils, the intermediate frequency transformer, and the second detector tube.

ohm resistor, R1. The other lug on C1 joins to the grid end of the oscillator grid coil, L4, and to the fixed plate lug on the G2 section of the gang condenser. The earth end of L4 is joined to one of the lugs on the padding condenser, PD, the other connection on which is earthed. The remaining lead on the grid leak R1 should be earthed and not, as shown in the circuit diagram, connected to cathode.

The cathode lug on the AK2 socket carries one lead of the .1 mfd. condenser, C2, and one lead of the 200-ohm resistor, R2. The vacant lead on C2 joins to earth, whilst the vacant lead on R2 is taken to the arm lug on the volume control potentiometer, VC. One of the outside lugs on VC is joined to earth, whilst the other outside lug is taken to the 25-volt tapping on the voltage divider, VD.

The metal coating lug, MC, on the AK2 socket joins to earth. The plate lug on this socket carries the plate lead from the intermediate frequency transformer, IF1, the "B" plus lead of which goes off to the 250-volt tap on the voltage divider, VD. The grid lead from IF1 is wired to one lug of the .0001 mfd. condenser, C5, across the lugs of which is connected the 1-megohm resistor, R3. The remaining lug on C5 carries a lead which terminates in the grid clip for the AF7 second detector tube. The earth end of IF1 is grounded.

The cathode lug on the AF7 socket joins to ground as do the suppressor and metal coating lugs on this socket. The screening grid lug on the AF7 socket carries one lead on the .1 mfd. condenser, C6, and a lead which joins to the 20-volt tap on the voltage divider, VD. The other lead on C6 is grounded

The plate lug on the AF7 socket carries one lead of the 500,000 ohm resistor, R4, and one lug of C7. The other lug on C7 joins to the control grid lug on the AL3 socket, V3, and to one lead of the 250,000-ohm resistor, R5. The other end of R5 is grounded. The vacant lead on R4 joins to the 250-volt tap on the voltage divider, VD. The cathode lug on the AL3 socket carries one lead of the 150-ohm resistor, R6, and the positive lead of the 25 mfd. electrolytic condenser C8. The remaining lead on R6 and the negative lead on C8 join to earth.

The only remaining wiring connections to be made are those to the primary of the power transformer. Connect the power supply flex between the common lug and the requisite one for the supply voltage on which the receiver is to be worked.

Alignment Details

When the wiring has been completed and checked over to make sure that no mistakes have been made, plug the four valves into their respective sockets and plug in the loud speaker; attach the aerial and earth leads and connect the set to the A.C. supply mains.

These valves are very quick heaters, so that the receiver will reach operating conditions in some 15 seconds. After the set has warmed up start on its alignment. For best results the intermediate frequency used should be 455 k.c., although quite good performance can be obtained from the standard 465 k.c. i.f.

The chief point to watch in using these Ferrocart intermediates is that, due to their extreme selectivity, correct alignment is absolutely necessary if signals are to be heard at all. The adjustment of the i.f. transformer trimmers will have to be carried out very carefully, because small alterations to the transformer's peaking, due to the efficiency of the tuning circuits.

With the i.f. transformer aligned properly, tune the set to 3XY or some similar low-wave station, and adjust the oscillator and modulator trimmers so that 3XY can be heard at from 10 to 15 on the dial. This done, tune up to 3AR and adjust the padding condenser, meanwhile rocking the gang condenser back and forth over a few degrees, for best signal strength.

Carry out these adjustments with the volume control retarded as far as possible, so that a definite peak setting can easily be determined. When the receiver is made to operate satisfactorily, and this should not be found difficult, it is capable of giving extraordinarily good results.

The power output from the pentode under average operating conditions will range between 2½ and 3 watts, with the 4½-watt reserve being always available to handle peak signals. The tone quality is pleasing and the selectivity all that could be desired.

To sum up, we may say that the set's excellent performance and simplicity of design should recommend it to all who are in search of a simple but efficient local receiver.

SOCKET CONNECTIONS

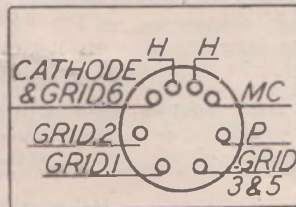

Fig. 1. The AK2 Socket Connections.

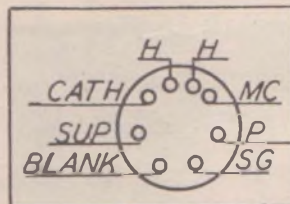

Fig. 2. Socket Connections of the A.F.7.

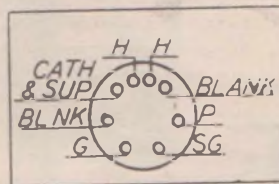

Fig. 3. The Connections for the A.L.3 Pentode.

All connections are as viewed from the underside of the base.

THE 1936 A.C. MASTER FIVE

A modern all-electric super-heterodyne receiver which possesses more than sufficient selectivity for present day conditions, has great sensitivity and is tonally faithful.

By A. K. BOX

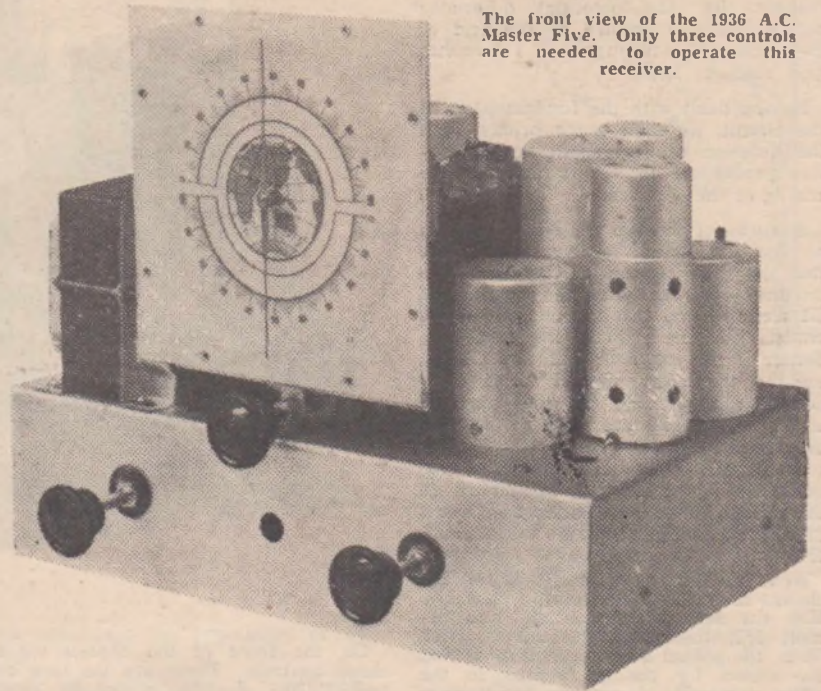

The front view of the 1936 A.C. Master Five. Only three controls are needed to operate this receiver.

THE last four months have seen a marked change in Australian receiving conditions. The placing on the air of a number of new stations, a feat made possible only by careful re-allocation of existing broadcast wave lengths, and the increasing of the power of existing stations, has made it more essential than ever that the broadcast listener be possessed of a highly selective receiver.

And this is not all. Plans for 1936 include the opening of more Regional Stations, some of which will have a power greater than any of the existing broadcasters, and the extension of the services provided by commercial stations.

Thus, instead of becoming simpler, the problem of the lis-

tener who wishes to roam the Commonwealth's airways in search of his radio entertainment is being further complicated. His difficulties can only be overcome with the aid of modern receivers which embody circuit refinements which were impossible of realisation in earlier types.

These include high selectivity intermediate frequency amplifier units, circuits which embody features making these amplifiers practicable, and modern high-gain valves which compensate for the losses attendant upon high i.f. selectivity.

The 1936 A.C. Master Five has been designed along "mechanised" principles so that, with the co-operation of enterprising trade houses, it is possible to present the receiver in complete kit form.

A STUDY of the schematic circuit diagram of the 1936 A.C. Master Five will show that the receiver incorporates a pre-selector stage in front of the mixer tuning, uses a 6A7 as

mixer tube and employs one intermediate frequency amplifier stage. The i.f. amplifier is followed by a 6B7s diode pentode as combined second detector and first audio tube. The output tube

is a type 42, the 6.3 volt replica of the 2A5. An 80 rectifier and the conventional power transformer provide the "B" supply, which is filtered by means of the loud speaker field winding and a pair of 8 mfd. electrolytics.

Because they offer greater selectivity than the high frequency type and at the same time possess greater gain, low, 175 k.c. type, intermediate frequency transformers have been used. This in turn necessitates the employment of a pre-selector stage, so that image interference will not be present in the receiver. Unlike most pre-selector systems, this one is inductively coupled, both coils being mounted in the one can and the coupling between them fixed at an optimum point.

This arrangement possesses the advantage of simplicity and limits the number of components required to build up the complete receiver.

This idea of simplicity and low cost—as far as is compatible with high grade performance — has been followed throughout the whole circuit. For instance, we find that automatic volume control has been dispensed with and use made of manual control obtained on the cathodes of the mixer and i.f. valves. A single by-pass condenser, C2, and a common bias resistor, R2, establish the minimum bias of 3 volts on these tubes. Bias variation to the cut-off voltage of 35 is obtained by means of the 5000 ohm potentiometer, VC.

The screening grids of the i.f. and mixer tubes and the oscillator plate of the latter tube all are fed from the 100 volt tap on the voltage divider, VD, and are provided with a common by-pass

condenser, C3, having a capacity of .1 mfd. For reasons of sensitivity as well as of selectivity, the 6B7s diode-pentode has been used as a diode-biased second detector. The 42 pentode output tube is "back-biased" by means of the 300 ohm resistor, R6, the potential difference across which is applied to the grid of the audio tube through the 1 megohm grid resistor, R5.

Having dealt with the fundamentals of the circuit, we shall touch briefly upon the question of component lay-out before proceeding to a description of the wiring of the receiver.

A study of the top chassis illustration of the completed receiver will show that the gang condenser, G1, G2, G3, is mounted centrally upon the chassis, the G1 section being that to the front of the chassis. To the right of the gang condenser is the oscillator coil can, L4, L5, and to the right of this latter component can be seen the hole through which adjustments are made to the padding condenser, PD. Behind the oscillator coil can is the can containing the aerial and mixer coils, L1, L2 and L3. In the right hand rear corner of the chassis is the first intermediate transformer, IF1.

Next in line along the rear of the chassis are the sockets for the i.f. valve, 6D6, the second intermediate transformer, IF2, the second detector socket, 6B7S, the socket for the pentode 42 and the socket for the 80 rectifier in the order mentioned. The power transformer is mounted in the front left-hand corner of the chassis, the electrolytic condensers, E1, E2, being mounted between PT and 42 and 80 sockets.

On the rear side of the chassis are mounted the aerial and earth terminals and the dynamic speaker input socket.

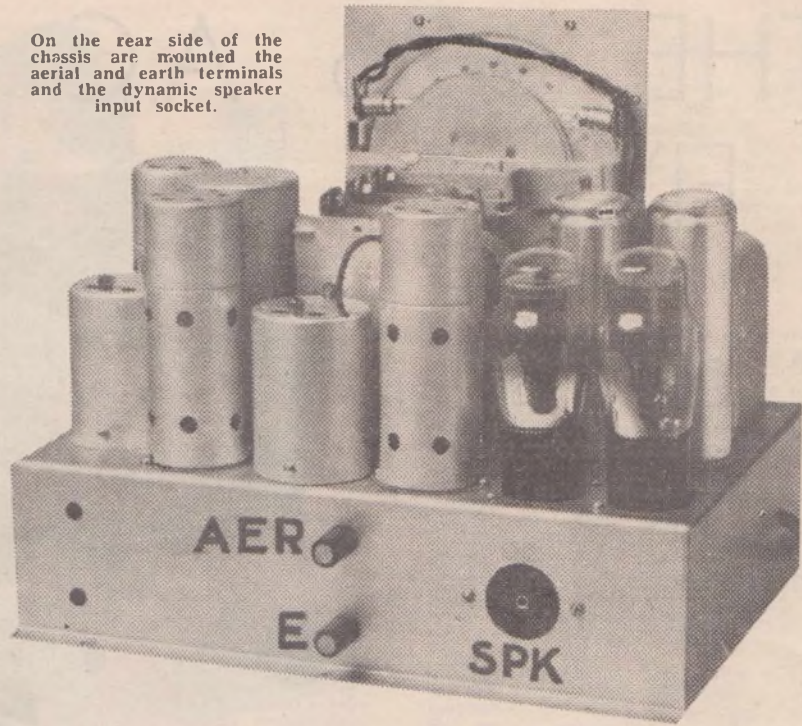

On the front of the chassis we see three controls. These are the tone control (left), the main tuning control (centre), and the volume control (right). Along the rear of the chassis we find the i.s. socket mounted below the socket for the 42, whilst the aerial and earth

terminals are to be seen at the right-hand end of the chassis. The rubber-grommeted outlet for the power lead is mounted on the left-hand side of the chassis alongside the power transformer.

The only components which have to be mounted on the underside of the chassis are the voltage divider, V.D., and the padding condenser, PD. PD already has been referred to, and VD is bolted to the right-hand end of the chassis during the wiring of the receiver.

Like the battery model of the 1936 Master Five this receiver has been designed particularly for the novice, and the wiring procedure has been divided into four easy and progressive stages. Besides providing point-to-point wiring diagrams of each four stages we shall describe the wiring connections progressively. It should be remembered, when following this wiring description, that each stage is complete in itself, and need not be referred to in proceeding to the next stage.

First Easy Step

Start by mounting the power transformer, PT, and the valve sockets as shown in Fig. 1. The power transformer is mounted with the "C," 240v. and 385v. lugs towards the front of the chassis. The 80 socket is mounted with its filament lugs facing the power transformer, whilst the filament lugs of the remaining sockets face the outside of the chassis. This is very important, as the directions of the wiring connections and consequent stability of the receiver depend upon the correct mounting of the sockets.

When mounting the sockets secure

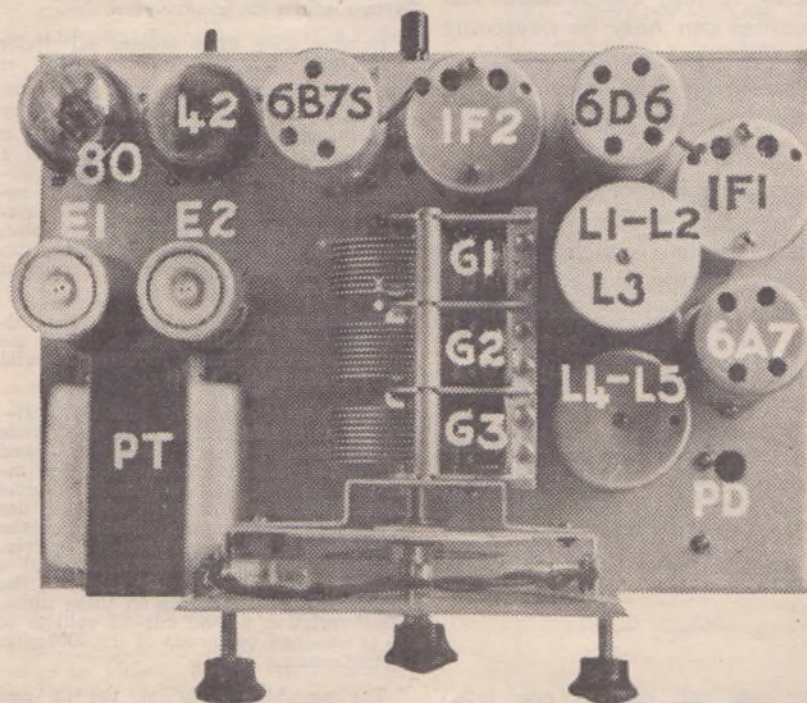

A plan view of the 1936 Master Five, illustrating the layout of components on top of the chassis. All parts are keyed to correspond with the written description of the receiver.

solder lugs underneath one of the mounting bolts. Details of these are shown in Fig. 2.

Start the wiring of the first stage at the 6A7 sock. Solder a RED lead to the C lug and a BLACK lead to each of the F lugs on this socket. The three wires should be long enough to reach the 6D6 socket, where the RED lead joins to the C and SU lugs on the 6D6 socket. Join the BLACK leads to the F lugs on the 6D6 socket. These three leads from the 6A7 to the 6D6 socket should be plaited together and taken around the edge of the chassis as shown in the point-to-point wiring diagram Fig. 1. With BLACK leads solder a wire from one F lug on the 6D6 socket to one F lug on the 6B7's socket and join the remaining F lug on each socket in a similar manner. These two wires should also be twisted together.

Take a lead from one F lug on the 6B7's socket to one F lug on the 42 socket and join the remaining F lug on each socket in a similar manner, twisting the two leads together as before. Take a lead from each of the F lugs on the 42 socket, twist the two leads together and take them to the 6.3 v. lugs on the power transformer, PT. Connect two leads each 12 inches in length to these lugs on PT, and twist them together and push them through the hole in the chassis as shown in Fig. 1. These leads later will be connected to the dial light holder.

Connect a red lead to each of the F lugs on the 80 socket. Twist these leads together and solder on to each of the 5 v. lugs on PT. Connect a pair of blue leads to the two P lugs on the 80 socket, twist them together and solder one to each of the 385 v. lugs on PT.

This completes the first stage of the wiring.

Check off against Fig. 1, and make sure that the solder connections have been made properly. It is desirable—even essential—that the wiring connections of this first stage be kept to the

outside of the chassis, made neatly, and placed exactly as shown in Fig. 1.

Second Easy Step

Join 6-inch leads to the three bottom fixed plate lugs of the gang condenser, G1, G2, G3. Then, with one inch bolts, and half inch pillars, mount the condenser in position and push the three leads through their respective holes in the chassis. Mount the two electrolytic condensers, E1 and E2, on the chassis, making sure to insulate E1 from contact with the chassis by means of the insulating washers provided. Mount the tuning coils, so that the oscillator coil is nearest to the front of the chassis.

In mounting the padding condenser, PD, arrange it so that access can be had to the adjustment screw through the hole in the top of the chassis. Use one-inch bolts and fit bakelite washers between the padding condenser and the pillars, and between the padding condenser and the securing nuts. This is necessary to prevent the possibility of cracking the isolantite base of the padding condenser during mounting operations.

Next mount the aerial and earth terminals. The top terminal (nearest to the bottom of the chassis side) is the earth terminal, and is the black one of the two. Use a large brass washer instead of a bakelite washer, between the chassis and the securing nut for this terminal. Insulate the aerial terminal from the chassis by means of a bakelite washer. The volume control, VC, and the tone control, TC, should now be mounted. The volume control shaft must be insulated from the chassis. The tone control is mounted at the power transformer end of the chassis, and is not insulated from it.

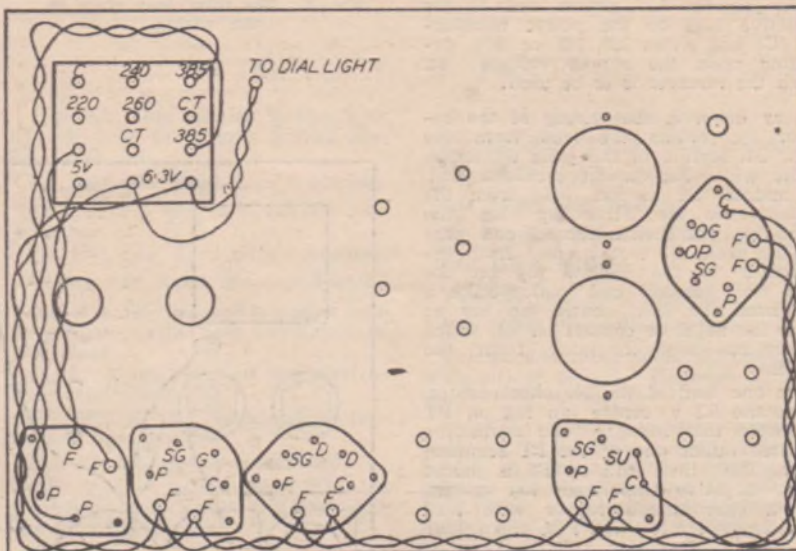

FIG. 1

The first easy stage shows how the power pack and the heaters terminals on all valves are wired.

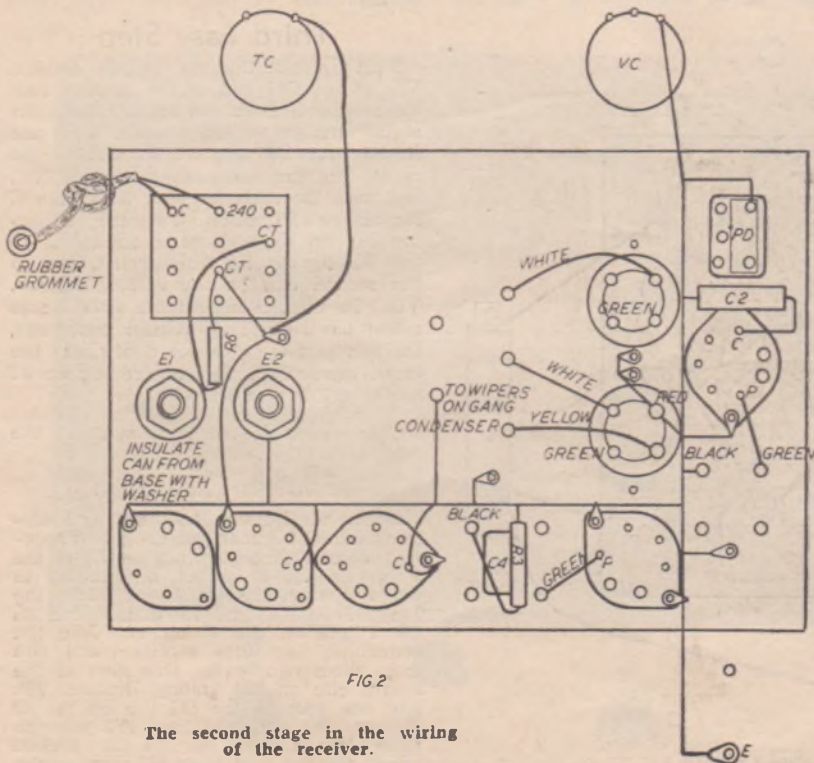

FIG. 2

The second stage in the wiring of the receiver.

Now join the A.C. power leads to the respective lugs on the power transformer (C) and either 220, 240, or 260v. depending upon the supply voltage on which the receiver is to be used.

Carry on with the wiring of the receiver by joining the lead from the front, G1, section of the gang condenser to the white lug on the oscillator coil, the middle, G2 section, lead from the condenser to the White lug on the modulator grid coil (second coil can) and the back, G3 section, lead from the condenser to the Yellow lug on the aerial coil (second coil can). Take a lead from the 385v. centre tap lug on PT to the negative contact on E1, which already has been insulated from the chassis.

Join one lead of the 300 ohm resistor, R6, to the 6.3 v. centre tap lug on PT and wire this lug to the earth lug mounted under one of the PT securing bolts. The other lead on R6 is joined to the negative (insulated) lug on E1. Run a bare tinned copper wire lead from the solder lug at PT to the solder lug on the 42 socket. Run a similar bare wire from the solder lug on the 80 socket, solder it to the corresponding lug on the 42 socket and similarly join it to the solder lugs on the 6D6 and 6A7 sockets. Continue this lead to join to the movable plate lug on the padding condenser, PD, and to one outside lug on the volume control, VC.

Join together the two solder lugs held under the mounting bolts for the two coil cans, continue this lead to the Red lug on the aerial coil, and thence to the earth wire. With bare wire run a lead from the earth terminal on the chassis to the back solder lug on the 6D6 socket and thence to the main earth wire. Solder one lead of the .1 mfd. condenser, C2, to the C lug on the 6A7 socket and solder its other lead to the earth wire.

Fig. 3. The third easy stage in the wiring.

FIG. 3

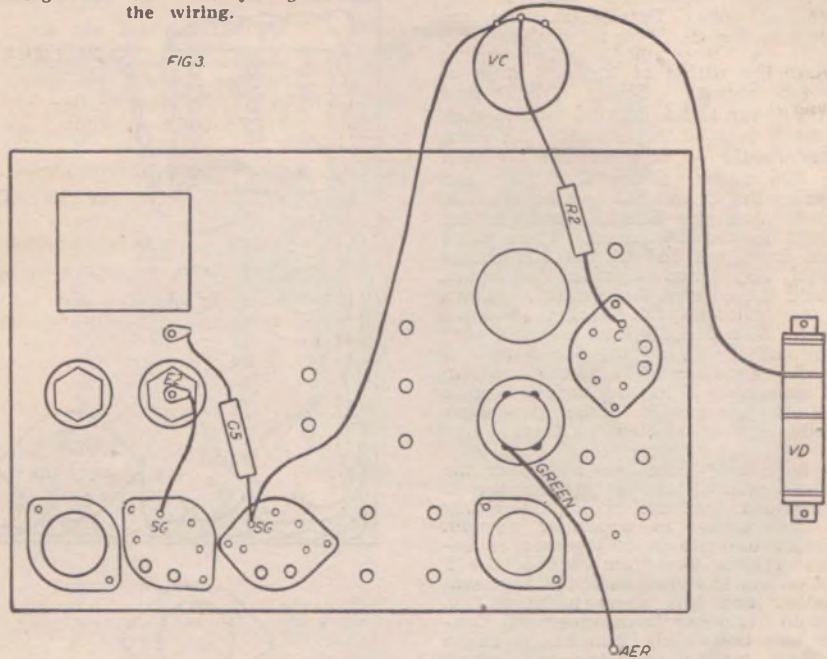

Mount the two i.f. transformers. IF1 is mounted nearest the 6A7 socket. In mounting these components place a solder lug under one of the securing bolts of each can. Join these solder lugs with bare wire to the main earth wire. Join the green lead from IF1 to the P lug on the 6A7 socket, and take the black lead from this same transformer to the P lug on the 6D6 socket, and take the black lead from this same transform-

mer to one lug of the .0005mfd. condenser, C4, and one lead of the 1 meg-ohm resistor, R3. The remaining lug on C4 and the remaining lead on R3 are joined to the earth wire. The C lug on the sockets for the 6B7s and 42 are joined to the earth wire, as is the negative lug on E2 and one lug of the tone control, TC. Run a bare tinned wire from the wiper lugs on the gang condenser sections to the main earth wire.

• This completes the second stage of the wiring.

Third Easy Step

Start by mounting the voltage divider, VD, at the 6A7 end of the chassis. Join the green lug from the aerial coil to the aerial terminal on the chassis. Join one lead of the 250 ohm resistor, R2, to the centre lug on the volume control, VC, and take the other lead on R2 to the C lug on the 6A7 socket. Join the remaining lug on the volume control, VC, to the SG lug on the 6B7s socket, and to the second clip on the voltage divider. VD. To the SG lug on the 6B7s socket solder one lead of the .1 mfd. condenser, C5, and join the other lead of C5 to the earth wire. Join the positive lug on E2 to the SG lug on the 42 socket.

This completes the third stage of the wiring.

Fourth Easy Step

Mount the l.s. socket so that its F terminals face towards the 42 and 80 sockets. Join the positive lug on E1 to the F lug on the 80 socket, and thence to one F lug on the l.s. socket. Join the lug immediately above this F lug to the P lug on the 42 socket. Join the remaining two lugs together and run from them two leads. One goes to the fourth clip on the voltage divider, VD, and one goes to the SG lug on the 42 socket. The red lead from IF2 joins to these linked lugs on the l.s. socket, whilst the red lead from IF1 joins to the

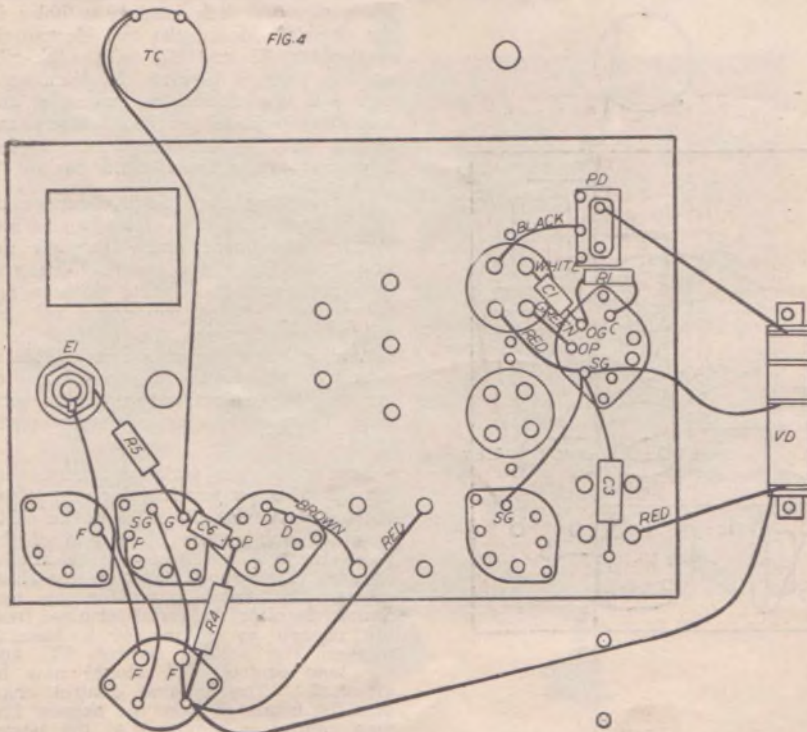

This diagram shows the final stage wiring.

fourth clip on the voltage divider, V.D. Join one lead of the .1 megohm resistor, R4, to the linked lugs on the I.s. socket, and solder the other lead on R4 to the P lug on the 6B7's socket, to which also is soldered one lug of the .01 mfd. condenser, C6.

The other lug on C6, one lead of the 1 megohm resistor, R5, and the remaining lug of the tone control, TC, are all soldered to the G lug on the 42 socket.

Join the remaining lead on the 1 megohm resistor, R5, to the negative lug on the electrolytic condenser, E1. Join the SG lug on the 6D6 socket to the corresponding lug on the 6A7 socket, and solder to this one lead of the .1 mfd. condenser, C3, and a lead which joins to the Red lug on the oscillator coil. From the SG lug on the 6A7 socket take a lead to the third clip on the voltage divider, VD. Solder the remaining lead on C3 to earth. Connect the black lug on the oscillator coil to the fixed plate lug on the padding condenser, P1, and join the Green lug on the same coil to the OP lug on the 6A7 socket. The White lug on the oscillator coil is soldered to one lug of the .0001 mfd. condenser, C1, the other lug of which carries one lead of the 50,000 ohm resistor, R1, and is soldered to the OG lug on the 6A7 socket. The remaining lead on R1 joins to the C lug on the 6A7 socket.

The Brown lead on IF2 solders to the two D lugs on the 6B7's socket. The first clip on the voltage divider, VD, is joined to the earth wire.

Now mount the tuning dial, set it at its correct reading with relation to the gang condenser, and tighten the bolts which secure the dial to the condenser shaft. Wire up the dial lights to the two flex lead, which has been brought up through the chassis.

This completes the wiring of the receiver, which now may be tested.

THE LIST OF PARTS

Coil Kit: One special Master Five coil kit, with three gang tuning condenser to suit.

C1: .0001 mfd. fixed mica condenser.
C2, C3, C5: .1 mfd. fixed tubular condensers.
C4: .0005 mfd. fixed mica condenser.
C6: 0.1 mfd. fixed mica condenser.

DS: Dynamic speaker to match type 42 pentode, with field resistance of 2500 ohms.

E1, E2: 8 mfd. 600 volt test electrolytic condensers.

IF1, IF2: 175 k.c. intermediate frequency transformers.

PD: 175 kc. padder condenser.

PT: Power transformer 385-0-385 secondary, one 5-volt winding and one 6.3 volt winding.

R1: 50,000 ohm resistor.
R2: 250 ohm 10 m.a. W.W. resistor.
R3, R5: 1 megohm resistors.
R4: 100,000 ohm resistor.
R6: 300 ohm 100 m.a. W.W. resistor.

TC: Tone control.
VC: 5000 ohm potentiometer.
VD: 25,000 ohm voltage divider.

Valves: 6A7, 6D6, 6B7S, 42 and 80 with sockets to suit. (Mullard, Philips, Radiotron, Raytheon).

Sundries: Three grid clips, rubber grommet, 4 pin valve socket, 2 terminals, 10 yards of belden wire, aluminium chassis measuring 12 inches by 8 inches by 3 inches, nuts, screws, three valve shields, vernier dial.

Tests And Adjustments

As a preliminary, plug in all valves except the rectifier. Plug in the power,

either an open or a short circuit. Incorrect wiring or faulty soldering will cause the first, while the second is likely to be present only in the case of the dial lights, which may be shorting to the frame of the dial.

RESISTER COLOR CODE

Value	Body	End	Dot
1 meg.	Brown	Black	Green
.1 meg.	Brown	Black	Yellow
.05 meg.	Green	Black	Orange

and see if all valves and the dial lights light up. If either the valves or the dial lights do not light, there must be

If everything is in order, plug in the speaker, and, without switching off the power, plug the rectifier valve into its socket. If this valve shows a blue glow or sparkles and flashes, switch the set off immediately, for something is wrong. Otherwise, connect the aerial and earth wires to their respective terminals and proceed to align the receiver.

First of all tune in a station on the dial between 0 and 20, and starting with the trimmer on the far off section of the gang, adjust it for the maximum volume. Do the same with the next trimmer. During this procedure have the trimmer on the oscillator section screwed almost full in, but do not adjust it.

Now turn to a station about 30 on the dial, and, with the volume low, slowly adjust the Padder and keep re-tuning the dial to get the loudest possible signal without touching the Volume Control. Again turn back to the stations on the low part of the dial and adjust the Band Pass and Aerial Sections of the gang for maximum volume.

The set should now be very sensitive, a slight adjustment of the I.F. Trimmers will increase volume again, but this should be carried out very carefully, and the slightest fraction at a time.

When the wiring has been completed according to the instructions provided, and the receiver aligned in the foregoing manner the set builder will find that he has a receiver capable of tuning in most of the Australian broadcasters, one which is highly sensitive, and above all, one which is capable of really fine tone quality.

In view of the ease with which it can be built and made to function satisfactorily, the 1936 A.C. Master Five can be particularly recommended to the novice, although its very performance will arouse the interest of the experienced set builder.

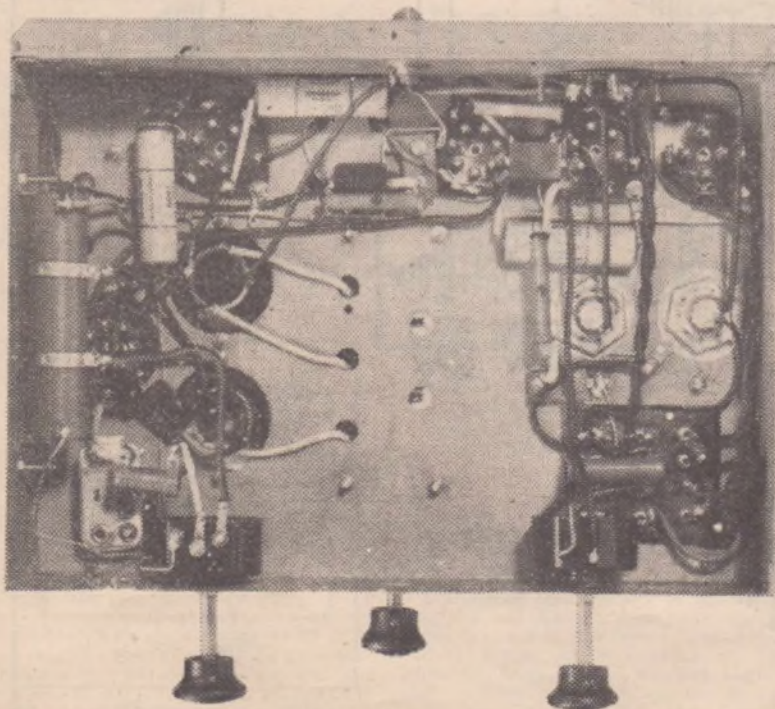

This view of the 1936 A.C. Master Five illustrates the wiring and layout of parts below the chassis.

The Schematic Circuit Diagram of
THE 1936 A.C. MASTER FIVE

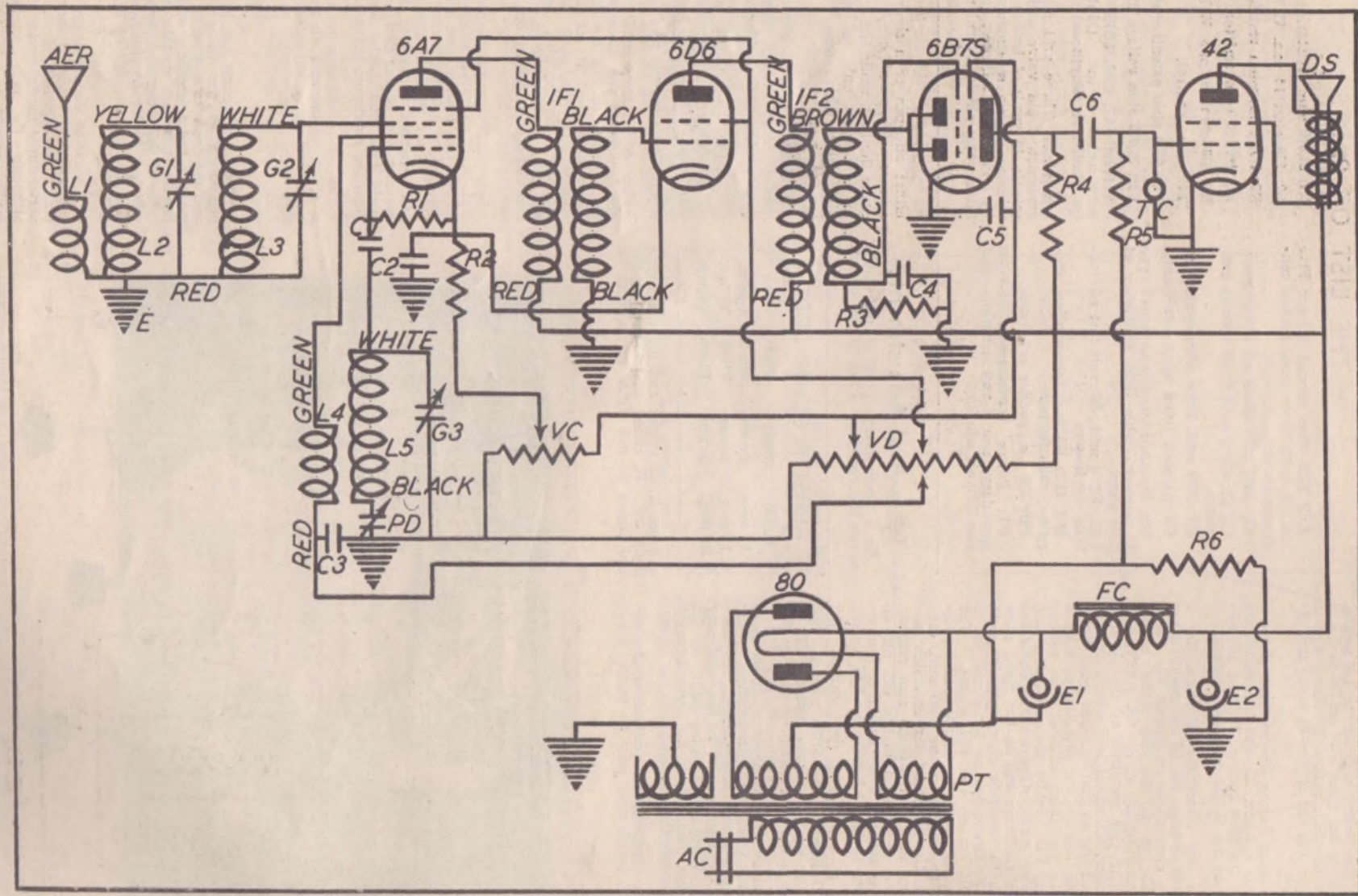

THE HARTWRIGHT CRYSTAL RECEIVER

An efficient and selective crystal receiver developed especially for Australian conditions.

DESPITE the advances made in the design of valve receivers, the simple crystal set is still the most economical form of radio.

It is simple to build, low in cost, and requires practically no replacements, for a good crystal will give long service unless it is improperly treated.

This receiver is the result of experiments conducted by a Queensland amateur, Mr F. W. Hartwright, after whom the circuit is named.

The original receiver has proved capable of tuning in "A" and "B" class stations at quite fair loud speaker strength when used within distances of seven miles from the stations. Naturally, it requires a high and well-constructed aerial to provide such excellent results.

Thus the building of such a receiver will not only give novices an entree to radio set-construction, but will result in their possessing a modern crystal set capable of separating the local stations and of providing worthwhile reception.

The schematic circuit diagram is shown in Fig. 1. The two coils, L1 and L2, serve, in conjunction with the two variable condensers, VC1 and VC2, to tune the receiver to the wavelength of the desired station. Impulses picked up by the aerial are fed from L1 to L2 by induction, and for this reason L2 must be in fairly close electrical relationship to L1.

The aerial coil, L1, is tapped by means of a four-point switch to permit varying degrees of selectivity. The higher the tapping the greater will be the volume and the lower the tapping the greater will be the selectivity. Thus, when the aerial is connected by the switch to the 20-turn tap, volume will be greatest, and when it is connected to the 35-turn tap the selectivity will be best. Intermediate taps provide variations between these two extremes.

The high frequency signal passed from the aerial through L1 to L2 is detected or rectified by the crystal detector, CD, which possesses the property of passing

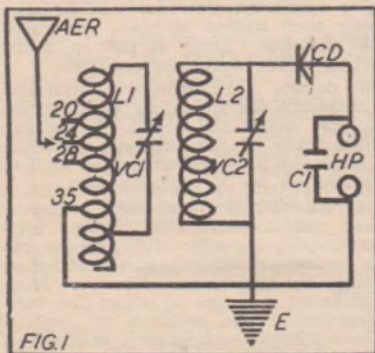

FIG. 1
The circuit diagram of the crystal receiver.

the low frequency alternations which the headphones convert into speech and music. The fixed condenser, C1, connected across the headphone terminals, assists the process of detection and improves the strength of the received signals.

Provided the builder studies the photographs of the original model of the crystal receiver no difficulty should be experienced in building the set.

The coils are wound on one piece of cardboard or bakelite former measur-

THE PARTS LIST

C1; .001 mfd. fixed mica condenser.

CD: Semi-fixed crystal detector.

VC1, VC2: .0005 mfd. variable tuning condensers.

Three point switch.

Sundries: 7 inches of 3 inch diameter coil former, 1/2 lb. of gauge 22 d.c.c. wire, four terminals, sheet of bakelite measuring 9 1/4 inches by 6 inches by 1/2 inch, 2 yds. belden wire, two vernier dials, one knob, wood screws.

ing three inches in diameter and seven inches in length. The gauge of the wire used is 22 D.C.C.

Commence the winding of the coils by starting coil L2 approximately one inch from the end of the former and winding on 45 turns. At a distance of about one inch from the L2 winding begin L1 coil. This coil will require 50 turns with tappings at the 20th, 24th, 28th, 35th and 40th turns.

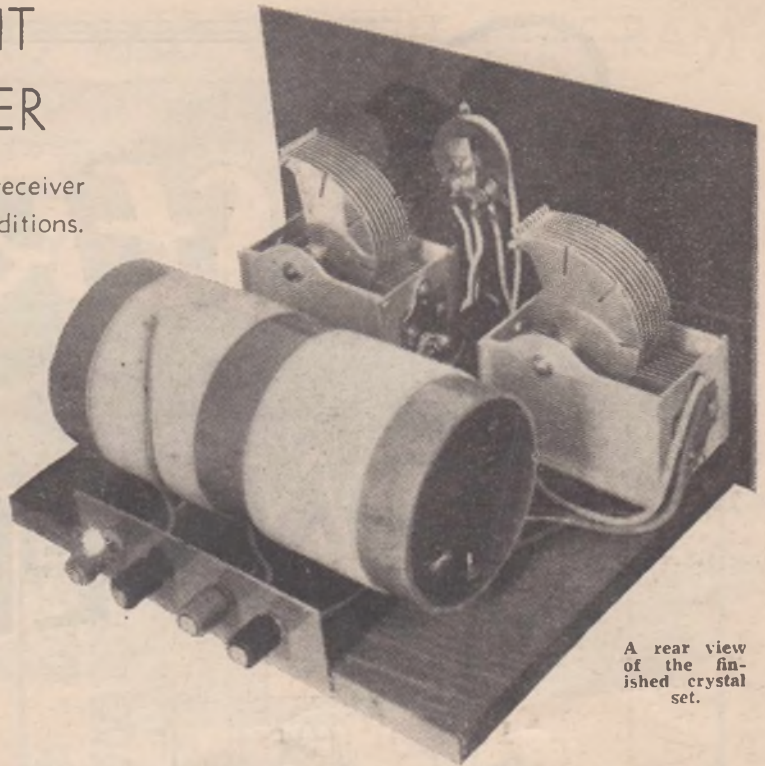

A rear view of the finished crystal set.

Mounting the Parts

On the front panel, which measures 9 1/4 inches by 6 inches, mount the two variable tuning condensers, VC1 and VC2, sufficiently far apart to allow the aerial switch, and the crystal detector to be assembled between them, as illustrated in the front view photograph of the original model.

Screw the baseboard, which measures 9 inches by 7 inches, to the front panel. Now mount the coil-former in the middle of the baseboard, keeping the windings on the former approximately half an inch from the wood by the use of small washers.

The terminal strip, consisting of the aerial, earth and the headphone terminals, is then screwed to the rear side of the baseboard.

Begin the wiring by taking a lead from the movable arm on the aerial tap switch to the aerial terminal on the terminal strip. Connect the three tappings (20th, 24th and 28th) on coil L1 to the three vacant terminals on the aerial tap switch, whilst the 35th turn tapping on L1 coil is joined to the earth terminal on the strip.

The variable tuning condenser, VC1, has its fixed plates joined to the start of the coil L1, and the movable plates on this condenser, VC1, are soldered to the 40th turn tap on the same coil (L1).

The beginning of the coil, L2, is secured to the fixed plates of VC2, and to one side of the crystal detector, CD. The other side of the detector, CD, is joined to one side of the fixed condenser C1 to one of the headphone terminals on the strip.

The other side of the fixed condenser, C1, and the remaining headphone terminal, are soldered to the movable plates of VC1, to the end of L2 coil, and to the earth terminal on the strip.



The CRUISER S/W CONVERTER

By H. R. SETFORD

MANY broadcast listeners read with envy the reports of the many overseas short-wave broadcasters received by possessors of dual-wave and all-wave receivers. Those listeners who are not fortunate enough to own receivers of this type and who have not had

the opportunity of tuning in to these overseas broadcasts because of the limited tuning range of their sets, must, when they read the reports of world-wide reception obtainable on the lower wave bands envy their more fortunate fellow listeners.

IN this article we deal with an A.C.-operated three-band converter suitable for connection to broadcast receivers of the superheterodyne or T.R.F. variety.

The unit tunes through the whole of the short-wave spectrum from 15 to 100 metres by the use of suitable coils and a three position selector switch. In spite of the writer's many and varied experiences with all types of shortwave receiving equipment he can honestly say that for sensitivity, stability and simplicity of operation this converter surpasses anything that he has yet heard.

The converter employs one of the latest all-metal valves and this, together with its simplicity of construction, will commend it to the advanced constructor and the novice alike.

If the directions given in this article are followed carefully, and all the original parts duplicated, there is no reason why anyone, even those who have never attempted the construction of radio apparatus before, should not be capable of turning out a really workable unit which will give the builder thrilling hours exploring the short-wave bands.

As mentioned previously, the converter makes use of one of the new all-metal valves which have evoked such interest among radio engineers throughout the world. The particular valve used

A highly sensitive short-wave converter which incorporates one of the latest all-metal tubes. This converter is capable of tuning from 15 to 100 metres with three sets of coils.

is a 6A8, the metal equivalent of the popular 6A7.

When it was decided to build this converter the use of standard size tuning condensers was vetoed because of the poor efficiency on the top end of the short-wave bands due to the high

capacity to inductance ratio occasioned by their use.

The condenser used in the original converter is a special short-wave two-gang condenser with a maximum capacity of .000175 mfd.

The two trimmers mounted on top of the gang are removed. Great care should be taken to ensure that the alignment of the tuning condenser is not disturbed in any way. The procedure adopted with the original condenser was to run a sharp knife along the bend in the adjustable plate of the trimmers until they are freed.

With the three sets of coils described the tuning spectrum of the receiver is divided into three bands, namely, 15 metres to 25 metres, 24 metres to 52 metres, and 49 metres to 100 metres.

Another feature arising from the use of a smaller tuning condenser is ease of tuning. The bands are spread over greater space on the dial, and, consequently each station occupies more dial space and the tuning is not so sharp as when wide bands are covered.

We cannot too strongly emphasise the necessity for intending constructors to follow, detail for detail, the wiring and assembly of the original converter and the need for duplicating the various parts needed for its construction.

The coil details have been carefully worked out in order that home constructors will have no difficulty as regards band coverage and condenser tracking, but should any departure from the make or capacity of either the tuning condenser, the padders, or the individual trimmer condensers, take place, the stated coil dimensions will not hold good and the constructor may spend months endeavoring to duplicate the results set out in this article.

THE LIST OF PARTS AND CIRCUIT DIAGRAM

FOR THE CRUISER S/W CONVERTER

Chassis. — Measures 8 inches by 8 inches by 3 inches. 16 gauge aluminium.

Coils.—See coil winding chart.
C1, C3, C4.—1 mfd. tubular condenser. (T.C.C.)

C2.—.0002 mfd. mica condenser. (T.C.C.)

F.T.— Filament transformer 1-6.3 volt winding. (Stedi-Power).

G1, G2.—Special two gang condenser. .000175 mfd.

PD1, PD2, PD3.—465 kc isolantite padder condensers. (Radiokes.) With fixed shunts of .006 mfd., .002 mfd. and .001 mfd. respectively.

R1.—250 ohm carbon or metallised resistor. (I.R.C.)

R2.—50,000 ohm carbon or metallised resistor. (I.R.C.)

R3.—300 ohm wire wound resistor. (Stedi-Power).

R4.—30,000 ohm carbon or metallised resistor.

R5.—25,000 ohm carbon or metallised resistor. (I.R.C.)

Switch.—Yaxley two gang five contact.

T1, T2, T3, T4, T5, T6. — Special trimmer condensers. (Radiokes.)

Terminals.—Four Radiokes press type.

Valve.—One only all metal type 6A8 complete with socket.

IF1.—Intermediate frequency transformer with coils closely coupled one trimmer disconnected. (Radiokraft).

Coil Material.—6 pieces of 1 inch diameter former 1 3/4 inches long. A reel of 24 gauge enamel wire. Small quantities of 34 gauge D.S.C. and 38 gauge D.S.C. wire. Two dozen small eyelets and six small aluminium mounting brackets.

Sundries.—Belden wire for wiring, small reel of tinned copper wire, nuts and bolts, solder lugs, mounting brackets for coil sub-panels, four pin plug and socket, power flex and adapter.

Circuit Features

A brief discussion on the various technical details of the circuit will assist those constructors who are technically inclined. The aerial is aperiodically coupled to the modulator grid of the 6A8, which is tuned by the G1 section of the gang condenser. The G2 section of this condenser tunes the oscillator grid coils which in conjunction with the padder condensers described allow of correct tracking over the three bands.

A 250 ohm resistor has been placed in the oscillator grid circuit to prevent undesired oscillator harmonics from interfering with the incoming signal. The switching arrangements are more or less standard and their functions may be seen by a glance at the schematic diagram. A voltage dividing system is used to supply the screen of the valve with its correct operating voltage resistors R4 and R5 constituting the divider.

The screen is by-passed to earth by condenser C4. The anode grid receives the full 250 volts from the "B" supply. IF1 transfers the signal energy from the plate of the converter valve to the aerial terminal of the broadcast receiver. This transformer must be specially wound so that its primary peaks at around 550 k.c. The secondary winding

has the same dimensions as the primary, but is untuned.

Construction:

The converter is built up on an aluminium chassis measuring 8 ins. by 8

inches by 3 inches deep. The gang condenser, comprising G1 and G2, is mounted on the top of the chassis in a central position, while directly beneath it is the wave changing switch. Mounted in the rear right-hand corner of the chassis is

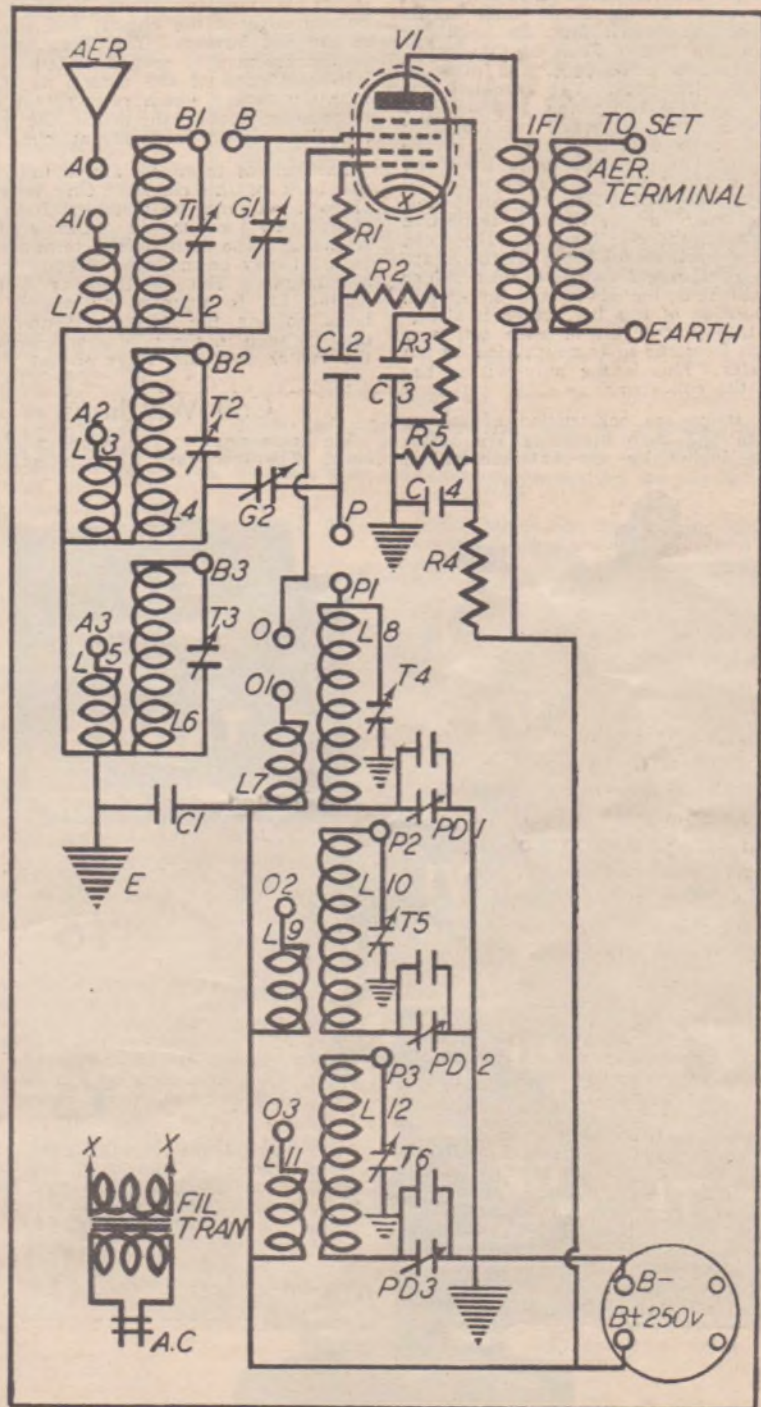

the filament transformer. The valve socket is bolted to the chassis directly behind the gang condenser, and to the rear right of this socket is the I.F. transformer.

The underneath view of the converter shows the coils mounted on their respective sub-panels, the aerial coils to the right of the switch and the oscillator coils to the left. Each of these sub-panels carries three coils, and three of the small trimmers. The trimmers are bolted to these sub-panels so that their adjusting screws may be adjusted through holes drilled in the top of the chassis. The connections to the fixed plates of the trimmers are brought out through holes drilled in the sub-panels and soldered directly to their respective contacts on the coil formers. The fixed plates of each set of three trimmers are joined together and connected to a solder lug which is bolted to the sub-panel. The position of this lug, which is alongside the centre coil of each set, may be seen from the underneath view of the converter. This is the only wiring beneath the coil strips.

The strips are constructed of canvas bakelite and each measures $5\frac{1}{2}$ inches by $2\frac{1}{2}$ inches by one-sixteenth of an

inch thick. Each strip is supported by two brackets, one of which is bolted to the front edge of the chassis and the other to the end. The depth from the floor of the chassis to the top of the sub-panel is 1 inch. The coil formers are each $1\frac{3}{4}$ inches in length so this leaves $\frac{1}{4}$ inch clearance between the bottom edge of the chassis and the top of the coil formers. The three padding condensers may be seen mounted on the left-hand edge of the chassis as is the four pin socket which receives the corresponding socket to which the earth and B maximum leads are attached.

Two sets of terminals are mounted on the back of the chassis. One terminal of each set must be insulated from the chassis by means of suitable fibre washers. The remaining terminal of each set may be mounted directly to the aluminium. The oscillator grid condenser, C2, is mounted on one of the bolts holding the gang condenser and may be seen in the photograph between the switch and the valve socket.

Coil Windings

We come next to the winding of the coils. The secondary of each coil, i.e.,

the winding which consists of the heavier gauge wire, is wound in the centre of its particular former. In the case of the modulator grid coils L1-L2, L3-L4, and L5-L6, the primary coils L1, L3 and L5 are wound nearest the top of the former and alongside the secondary coil. In the case of these three sets of coils it is essential that they be wound in the same direction.

The connections to these three sets of coils are exactly the same. The top contact of the primary or aerial coil connects to its respective switch contact of the bank "A" of the wave change switch. The end of the aerial coil and the beginning of the secondary coil connect to earth or chassis. The remaining end of the secondary connects to its respective contact of "B" bank of the wave-changing switch.

In the case of the oscillator coils the second coils are wound in the centre of the former with the primary or feedback coils wound over the bottom turns and in the reverse direction to the secondary coil. This was accomplished in the following manner:—

The secondary coil was first wound and its ends secured to eyelets placed at the ends of each former, as shown in the coil diagram. A narrow strip of empire cloth was secured in place on top of the secondary coil with sealing wax. The beginning of the over-wound coil was passed through the same hole as the secondary winding and secured to its eyelet. The required number of turns were then wound and a spot of sealing wax used to secure the wire to the empire cloth. The end of the wire was then soldered to the remaining terminal on the former. Each of the coils is fixed to the sub-panel by means of a small aluminium bracket, measuring $\frac{3}{4}$ of an inch by $\frac{1}{4}$ of an inch. The positions of these brackets may be seen from the underneath views of the completed converter. It is most important when winding the coils to remember that while the windings for the modulator coils are wound in the same direction, the windings of the oscillator coils are in the reverse direction to one another.

When the coils have been wound and secured to their respective mounting strips and all other components have been mounted, the wiring may be commenced.

Solder a wire to contact 2 of the valve socket and connect it to one side of the 6.3 volt winding on F.T. Solder another lead to the remaining side of the 6.3 volt winding and twist it around the first lead. The free end of this wire joins to contact 7 of the valve socket and to earth. Connect together the number 1 and 8 contacts of the valve socket and solder to them one side of R3, C3 and R2.

The remaining ends of C3 and R3 connect to earth, while that of R2 joins to one side of C2.

R1 connects between this same contact and pin number 5 of the valve socket. Resistor R4 is connected between the large pin of the "B" supply socket which connects to "B" maximum and one of the smaller pins of the same socket. A flex lead is soldered to this pin and joins to terminal number 4 on the valve socket. Resistor R5 connects from this point to earth as does condenser C4.

We come now to the switch connections, and great care must be taken to see that these are wired correctly. The switch used in the original converter is a Yaxley, two gang having four sets of five

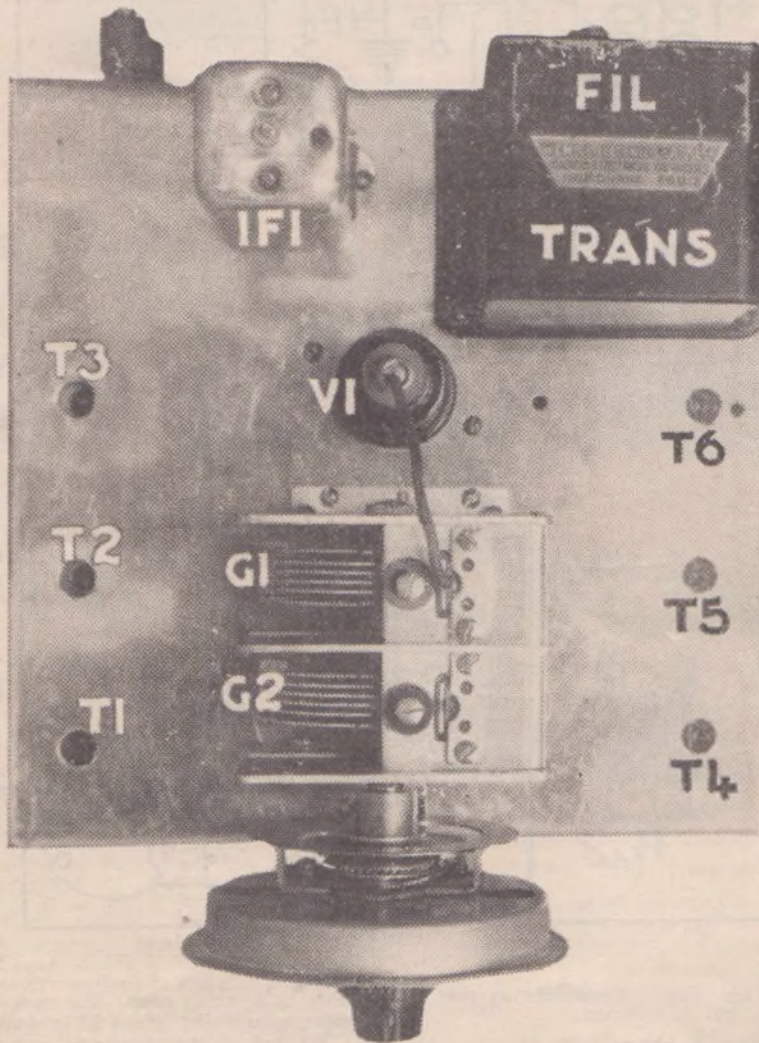

This plan view of the short-wave converter illustrates the arrangement of parts on top of the chassis. All components are keyed to correspond with the schematic circuit diagram and the written description of the set.

contacts. In this particular instance only three of the available five contacts are in use. In order to simplify the connection of this switch a brief description of the position of the contacts which are wired to the various components will be given.

Before mounting the switch, examine it carefully, and it will be seen that besides the four sets of five contacts mentioned previously there are four separate contacts provided, which are mounted on the opposite side of the bakelite supports which carry these contacts. These separate lugs are the connections to the arms of the selector switch. If the switch is mounted in the same way as the underneath photograph shows, two of these arm contacts are located above the supporting pillar on the right hand side of the switch. The one nearest the front of the chassis connects to the vacant contact of the condenser, C2, while the one towards the rear of the chassis joins to the aerial terminal.

The two remaining arm contacts are beneath the supporting pillar on the left of the switch. These contacts should have wire soldered to them before the switch is mounted in position. The wire soldered to the one nearest the front of the chassis connects to contact number 6 on the valve socket, whilst the wire joined to the other contact solders to the fixed plate lug beneath the rear section of the gang condenser. The corresponding lug of the front section of the gang condenser connects to the contact of C2, which is already wired to the lug of the switch.

Solder a lead to the fixed plate lug on top of the rear section of the gang condenser and attach the grid clip for the 6A8.

Now connect the coils to their respective contacts. The underneath view of the converter should be kept handy, and the wires traced on the illustration as they are described. The first contact to be connected is the one beneath the pillar on the right of the switch, nearest the front of the chassis. This contact solders to contact O1 on the oscillator coil near the front of the chassis. The next contact of this bank joins to terminal O2, on the second oscillator coil, and the third contact to terminal O3 on the third oscillator coil. This coil is the one toward the rear of the chassis.

Contact B1 of the modulator coil nearest the front of the chassis joins to first contact of the second gang of the switch on the right-hand side. We are now speaking of the underneath set of five contacts. The second contact of this bank connects to terminal B2 of the second modulator coil, whilst the third one joins to terminal B3 of the third modulator coil. All that requires to be connected now are the two top sets of contacts. The first contact on the left-hand side of the section nearest the front of the chassis solders

to terminal P1 of the oscillator coil nearest the front of the chassis. The second contact of this section of the switch joins to terminal P2 of the second oscillator coil, whilst the third contact connects to terminal P3 of the third oscillator coil.

Only three contacts of the switch remain to be connected, the first contact on the left of the rear section joins to terminal A1 on the aerial coil nearest the front of the chassis. The second contact of this bank connects to A2 on the second aerial coil, whilst the third one joins to A3 on the third aerial coil. This completes the wiring to the switch, and it is advisable carefully to check and re-check these connections to see that they are wired correctly. Any mistake in these connections will prevent the converter from operating.

The E contacts of the three sets of modulator coils are connected together and taken to the earth lug on the modulator coil sub-panel.

Connect together, by means of the tinned wire, the moving plates of the three padder condensers and join them to the solder lug, to which is connected the lead from the moving plates of the three trimmers beneath the oscillator coil sub-panel. Contact PD of the oscillator coil, nearest the front of the chassis, connects to the fixed plates of the first padder condenser. Contact PD of the second oscillator coil solders to the fixed plates of the second padder condenser, and, similarly, the PD terminal of the third oscillator coil joins to the fixed plates of the third padder condenser.

Three unconnected contacts remain on the oscillator coils, and these are joined together with tinned wire covered with spaghetti and wired to the "B" maximum contact of the "B" supply socket. This lead can be distinctly seen in the underneath view of the completed converter.

The intermediate transformer, IF1, should now be connected to the circuit. Contact number three of the valve socket joins to the P contact of this component the "B" positive terminal of which solders to the "B" maximum pin of the "B" supply socket. One lead of the untuned side of this component, i.e., the

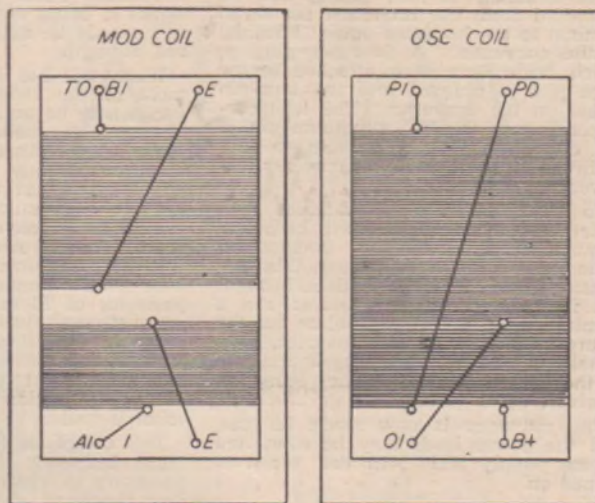

These two diagrams illustrate how the modulator and oscillator coils are wound. Note how the ends of each winding terminate at the ends of the formers. These drawings show the wiring connections for the first set of coils.

winding which has the trimmer removed, connects to the insulated terminal situated beneath the filament transformer. The remaining lead of IF1 joins to earth.

Condenser C1 may now be soldered into circuit between the "B" maximum pin of the "B" supply socket and earth. The two earth return solder lugs on the coil sub-panels should be connected together, and wired, with tinned wire, to the earth terminals. These terminals are those mounted directly on the aluminium chassis. The padder shunt condensers may now be soldered in position. One of .006 mfd. capacity connects between the fixed plates of PD1 and earth, whilst condensers of .002 mfd. and .001 respectively connect between the fixed plates of padder condensers, PD2 and PD3, and earth.

All that remains to be done now is to connect the power leads to the correct voltage tapping on the filament transformer.

Adjustments

Having completed and thoroughly checked the wiring, the converter is now ready for its initial adjustments. At this stage it may be as well to mention that the results to be expected from this converter are really dependent on the sensitivity of the receiver to which it is connected.

It stands to reason that with it connected to a multi-tube superheterodyne results will be better than if it is connected to a straight T.R.F. receiver, because of the greater gain obtainable from the former type of set. Suffice to say that the converter itself is one of the most sensitive of its type which we have yet handled, and excellent results can be obtained even though it is connected to a T.R.F. receiver.

It is necessary first to connect the converter to the broadcast receiver. In order to avoid confusion we will designate the two sets of terminals on the rear of the chassis as input and output. The output set consists of those situated beneath the filament transformer. The aerial lead is removed from the broadcast set and attached to the input aerial terminal of the converter.

The earth lead is removed from the broadcast set and attached to the other

COIL WINDING DETAILS

Metres.	Aerial.	Modulator.	Feedback.	Oscillator.
15-25	10	3½	4	3
24-52	15	9	6	8
49-100	20	20	7	18
Wire gauge	38	24	34	24

D.S.C. Enamel. D.S.C. Enamel.

Modulator and oscillator coils for the 15-20 metre band are spaced one diameter of the wire. All remaining coils are close wound.

input terminal. A lead should now be connected from the broadcast set aerial terminal to the insulated output terminal of the converter. A four-pin plug to which leads have been attached to the large pins is plugged into the four-pin socket on the converter. The lead corresponding to the "B" maximum pin of the converter socket connects to "B" positive 250 volts in the broadcast receiver.

To those who are not familiar with their broadcast receivers it will be necessary to get someone who understands radio to show them just where this lead is connected. A lead should be brought out from the broadcast receiver and a terminal attached to the cabinet for the future connection of the converter. The remaining lead from the plug is attached to the earth terminal of the broadcast receiver.

The converter is now ready for use, and the power leads may be connected to the supply and both the receivers turned on.

The broadcast receiver must be tuned to a position between 3AR and 2CR, where no signals are received, and the volume control fully advanced. It should now be possible to pick up a station on one of the short wave bands. For the purpose of this first adjustment it does

not matter which band is used. When a signal is being received the trimmer on I.F1 should be adjusted for greatest signal strength.

When this has been done the adjustment of the converter for the various bands may be undertaken. First set the band selector switch to place the lower wave-length coils in position and tune in a station as low down on the dial as possible. Adjust the trimmers, T1 and T4, for maximum signal strength. In the original converter these two trimmers were screwed nearly full in, as was the adjustment screw on the variable padder condenser. When the adjustment of T1 and T4 produces maximum strength, tune a station on the high end of the dial and adjust the padder condenser for maximum results. During this adjustment it will be necessary to retune the station each time any adjustment is made.

This completes the adjustment for this band, but some slight alteration may be necessary to trimmers T1 and T4 in order that the band stated may be covered.

When the converter is aligned on this first band the stations on the 25 metre band should be received at between 90 and 100 degrees on the dial. If these stations are found to be lower than this the trimmers should be screwed further out

and the converter realigned. When the stations occupy approximately the position stated the band switch may be altered to connect the next set of coils in position. The same procedure is adopted in the alignment for this band as for the previous one except that the adjustments are carried out on trimmers T2 and T5 and padder condenser Pd2.

With the tuning condenser full out on the second band it should be possible to receive one or two of the stations which were received on the lower band with the condenser in the full-in position. The trimmers should be screwed either in or out until an adjustment is reached which allows this tuning overlap to be obtained. The switch may now be changed once more to connect the highest wave-length coils in position and the previous adjustments repeated with trimmers T3 and T6. All the adjustments for this set of coils should be carried out on trimmers T3 and T6 and padder condenser Pd3. The same condition should apply to this band as the previous one. A station which was received on the middle band with the condenser full in should be received on the high band with the condenser plates full out.

The sensitivity of the finished converter depends greatly on the care which is taken in making the adjustments described, and, although they no doubt sound very complicated, in actual practice, because of the time which has been spent in arranging a suitable layout and in designing the coils, readers should have no difficulty in duplicating the results obtained from the original unit. This is subject to the proviso—and we cannot stress this point too much—that every care has been taken to duplicate both the parts and the layout of the original converter.

Now for the results obtained. Operated in conjunction with a commercial five-valve superheterodyne receiver and connected to an outside aerial of average dimensions the results were absolutely astounding. Compared with an all wave receiver under exactly similar conditions, the converter came through with flying colors. The noise level with the converter was found to be much lower than that of the all-wave receiver against which it was tested. This comparison also showed up the converter's greater ease of tuning.

Stations on the lower bands were received at full speaker strength, and no doubt when the period for the higher bands come round builders of this converter will be able to obtain excellent results on this band as well as on the lower ones.

All in all, this converter can be thoroughly recommended to anyone who is desirous of receiving short wave transmissions on their present broadcast receiver. It is simple enough for even the novice to build, yet so efficient as to be worthy of serious consideration by the experienced technician.

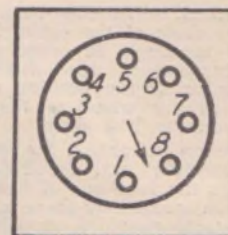

A diagram showing the correct wiring connections for the 6A8 valve socket. These connections are shown as viewed from below and are: No. 1, the shell; No. 2, heater; No. 3 plate; No. 4, screen; No. 5, oscillator grid; No. 6, oscillator plate; No. 7, heater; No. 8 cathode.

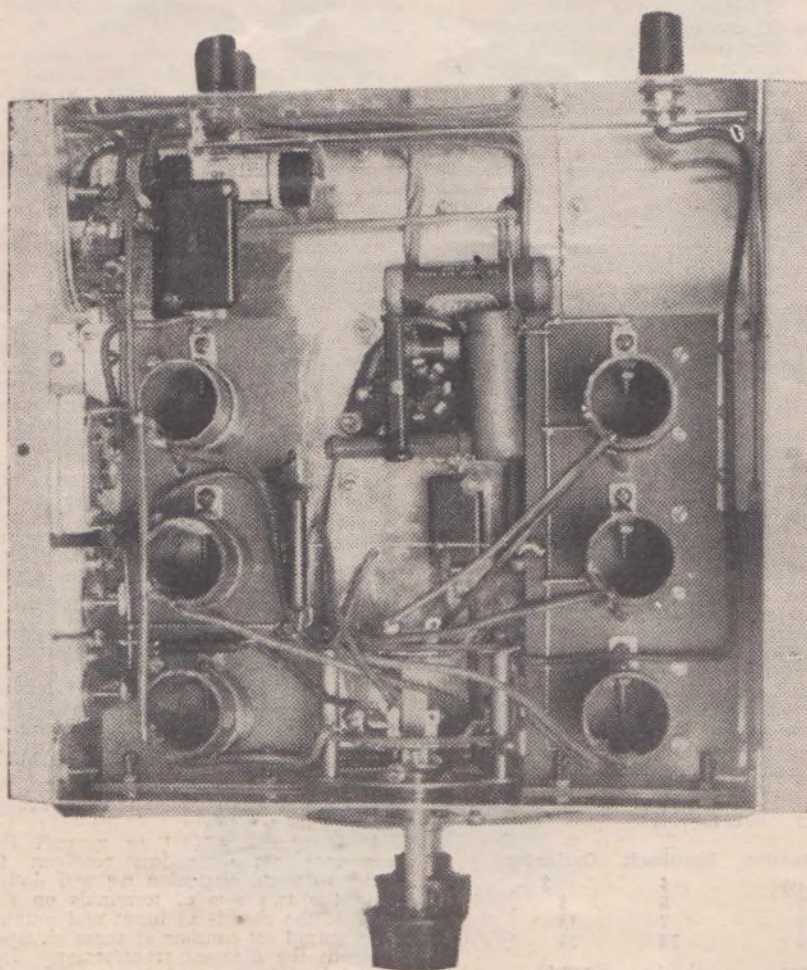

An underneath photograph of the converter showing the mounting positions of the three sets of coils. They are arranged with the 15 to 25 metre coils nearest the front of the chassis, the 24 to 52 metre coils in the centre, and the 49 to 100 metre coils at the rear.

The MIGHTY ATOM

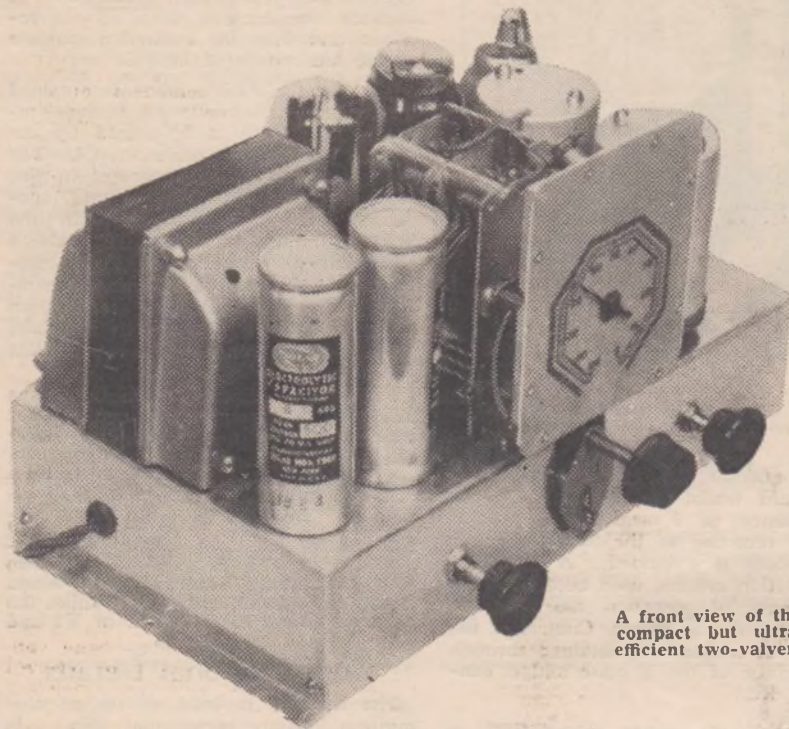

A front view of this compact but ultra-efficient two-valver.

Here are full constructional details of an amazingly efficient two-valver which uses the new iron dust tuning coils.

By A. K. BOX

THE harsh illumination of the technical searchlight which is focussed on the advances taking place in the design of the modern superheterodyne receiver often bedazzles the man who is interested chiefly in small sets. This individual forgets that the technical achievements of the large set designer also have a bearing upon the performance of his particular type of small set.

One of the features of radio from the home constructor's viewpoint is that feeling of getting "something for nothing" which attaches to the design of a particularly sensitive receiver.

The undoubted attributes of the superheterodyne when sensitivity and selectivity are considered has dealt what would appear to be a deathblow to receivers using other types of circuits. Recent technical developments, however, have offered a

means of revitalising the humble "two" or "three" so that it now is possible to build such small receivers with the knowledge that, with due regard to the number of valves they employ, these receivers will provide results comparable with those obtainable from the large types.

The most important of these are modern valves. We have referred to the revolutionary AL3 pentode, which is capable of providing a power output of some 4½ watts when provided with an input signal of only 3.5 volts.

Next in importance comes the newly developed iron-cored tuning coils, in which cores of the high permeability alloys such as Crolite and Ferrocart are employed to increase the electrical efficiency of the coils by some 70 to 100 per cent. Taken together, these two developments offer the small set builder an entirely new conception of receiver design.

APTLY called "The Mighty Three," this little receiver possesses many of the characteristics which would normally be looked for only in a receiver using twice its number of valves. Chief among these is a selectivity which is more than sufficient to eliminate 3DB from either 3KZ or 3UZ when operating under the former station's aerial (actually, under these conditions 3DB occupies a space of only six degrees on the tuning dial). Next is the receiver's sensitivity, which is of the comparatively high order of 240 microvolts figure which promises—and fulfils the promise—interstate reception at entertainment value. The set's high sensitivity, coupled with its great selectivity, makes it possible for reception to be really enjoyed from the majority of the interstate broadcasters.

Now glance at the schematic circuit diagram whilst we explain the design features which make possible such an astounding performance from a three valve receiver.

It will be seen that a pre-selector stage is used in front of the main tuning stage of the regenerative detector which is a high impedance Mullard type AF7 tube. The fact that Crolite iron-cored coils have been employed in the receiver makes practicable the use of pre-selection—which still further increases the receiver's selectivity—without marked reduction in sensitivity. The aerial coil is of the capacity coupled high impedance type in which the primary winding, L1, resonates at the top end of the broadcast wave band (low frequency end of the spectrum) and thus ensures that no fall off in sensitivity will take place there.

Iron Core's Advantages

Coupling between the aerial and the pre-selector coil, L2, is obtained by means of the small condenser, CX,

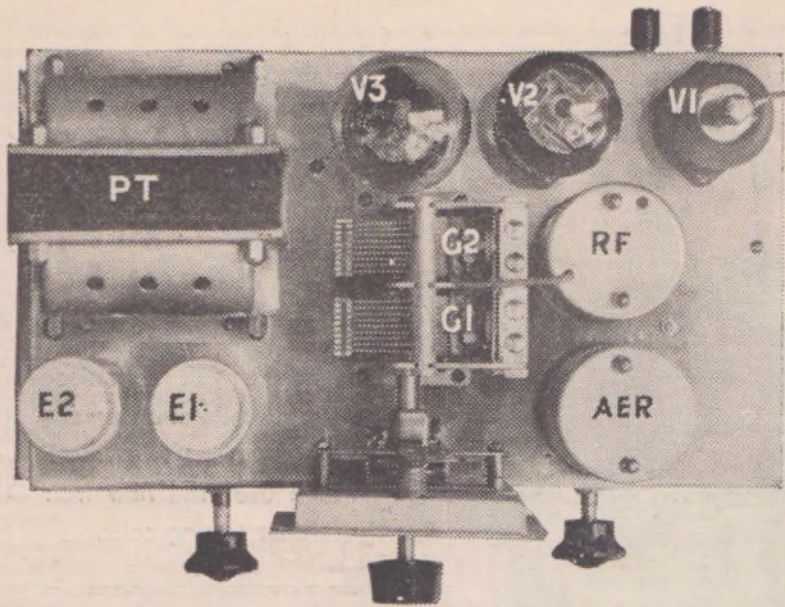

A key-lettered plan view of the original chassis showing the placement of the various components.

which, in the case of the commercially manufactured coils used in the original receiver, is pre-set to the optimum value. L2 is tuned by the G1 section of a Stromberg Carlson type G two-gang tuning condenser. The detector grid coil, L3, is a similar iron cored coil, and is tuned by the G2 section of the two-gang condenser. Coupling between the two coils, L2 and L3, is effected by means of the coupling coil, L4, and the resistor, R1, which has a value of 25,000 ohms and is shunted across L4.

Coupled to L3 is a reaction coil, L5, which is used to apply regeneration to the detector valve, V1, and thus increase the receiver's sensitivity.

Before going further it might be desirable to touch upon the peculiar properties of these tuning coils. First and foremost they have incorporated in their construction a small cylindrical pellet made up of finely ground particles of a special iron alloy. The introduction of this iron core into the electromagnetic field of a tuning coil has the effect of raising tremendously the "Q Factor" or efficiency factor of the coil. For other reasons, which we shall not enter upon here, an increase in the "Q" factor also means an increase in the selectivity of the tuned circuit with which the coils are associated. So, we find, not only do we increase the sensitivity of a receiver equipped with iron-cored coils, but we also increase its selectivity.

In the case under review the special coils, made expressly for The Listener In by "Radiokraft," 131 Brunswick Road, East Brunswick, possess the feature of being wound with high-grade German litzendraht wire which raises their efficiency still further, and warrants our claim that they are the most efficient tuning coils yet developed in Australia.

Further Circuit Details

To go back to the circuit diagram we find that the AF7 high gain pentode detector tube is used as a leaky grid detector in which circuit arrangement it is most responsive to weak signals. The

grid condenser, C1, has a capacity of .00025 mfd. whilst the grid leak, R2, has a resistance of 2 megohms. The grid leak is returned to the cathode of the tube which is grounded. A shunt-fed regeneration system, used because of its smoothness of operation, has been incorporated in the design. Control of the amount of feedback is obtained through the medium of the 23 plate midget condenser, RC.

The radio frequency choke, RFC, is employed to keep unwanted currents from entering the audio amplifier tube, V2, through the coupling condenser, V3. It has been necessary, because of the high impedance of the AF7, to resistance

couple this tube to the Mullard AL3 pentode audio valve. The plate resistance, R3, is a .1 megohm resistor, the coupling condenser, C3, has a capacity of .1 mfd. and the grid resistor, R4, has a resistance of .25 megohm. The screening grid voltage for V1 is not critical but should be set at 30 volts for best results. This potential is obtained from the voltage divider, VD which serves also to increase the current drain of the receiver and thus the excitation wattage of the loudspeaker field FC.

Bias for the AL3 pentode is obtained through the conventional cathode resistor, R5, which is by-passed by the 25 mfd. electrolytic condenser, C4. The tone compensation arrangement in this receiver is variable. The .05 mfd. condenser, C6, in conjunction with the 50,000 ohm variable resistor, TC, allows a wide range of compensation. Fixed compensation, to a degree sufficient to compensate for the high note accentuation of the pentode, is provided by the fixed condenser, C5, connected between plate and screen.

Filtration is obtained by means of the 2500 ohm field coil of the loud speaker which is by-passed by the two filter condensers, E1 and E2, each of which are 8 mfd electrolytics. The power transformer is capable of providing 400 volts at a current of 60 m.a. on each side of the centre tap of the high voltage winding. It is provided with two four volt filament windings, one of which is for the rectifier valve, V3, whilst the other supplies the filaments of V1 and V2.

Constructional Details

The receiver is built up on an aluminium chassis measuring 12in. in length, 7in. in width, and 2½in. in depth. An idea of the lay-out of the components on the top of the chassis can be obtained from a study of the photographs of the finished receiver. From these it will be seen that the

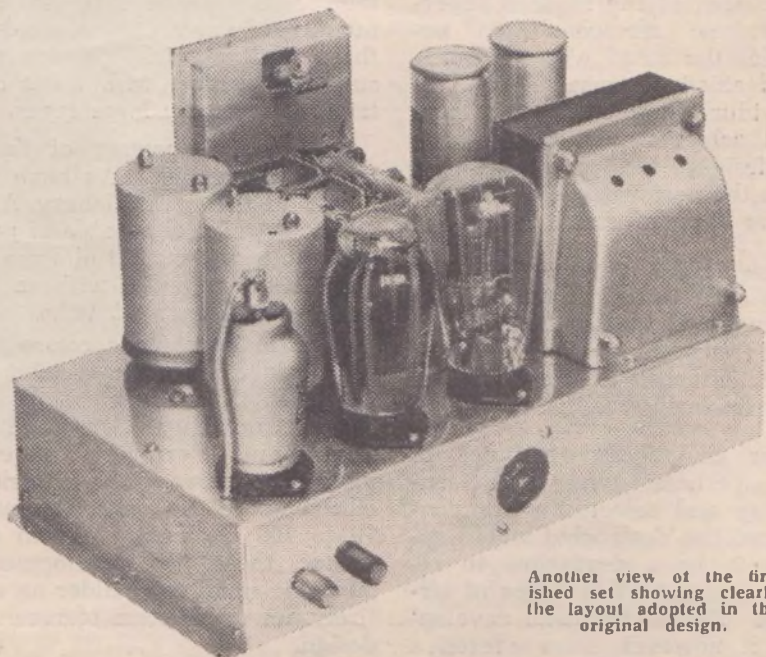

Another view of the finished set showing clearly the layout adopted in the original design.

power transformer is mounted in the far left-hand corner. To the right of the power transformer are the sockets for the 1561, the AL3, and the AF7, in the order mentioned. The gang condenser is centrally mounted. To the right of it are the cans containing L1-L2 (front) and L3-L5 (rear).

The electrolytic condensers, E1 and E2, are mounted to the left of the gang condenser and just in front of the power transformer. Along the rear of the chassis we find the aerial and earth terminals, and the socket for the loud speaker plug. The three controls on the front of the chassis are the tone control (left), the tuning control (centre), and the reaction control (right). The power supply leads have been brought out through a rubber grommetted hole at the left-hand end of the chassis.

The only components to be mounted underneath the chassis is the voltage divider, VD; the coupling coil, L4; the grid condenser, C1; and the radio frequency choke, RFC. All other components are wired directly into circuit.

Point to Point Wiring

When the assembly of the receiver has been completed, the wiring may be started by running a lead from one of the four-volt valve filament lugs on the power transformer to one filament lug on the sockets for V1 and V2. From the other lug on the four-volt valve filament winding runs a lead to the remaining filament lug on V1 and V2. Take a lead from one lug of the other four-volt winding on the transformer to

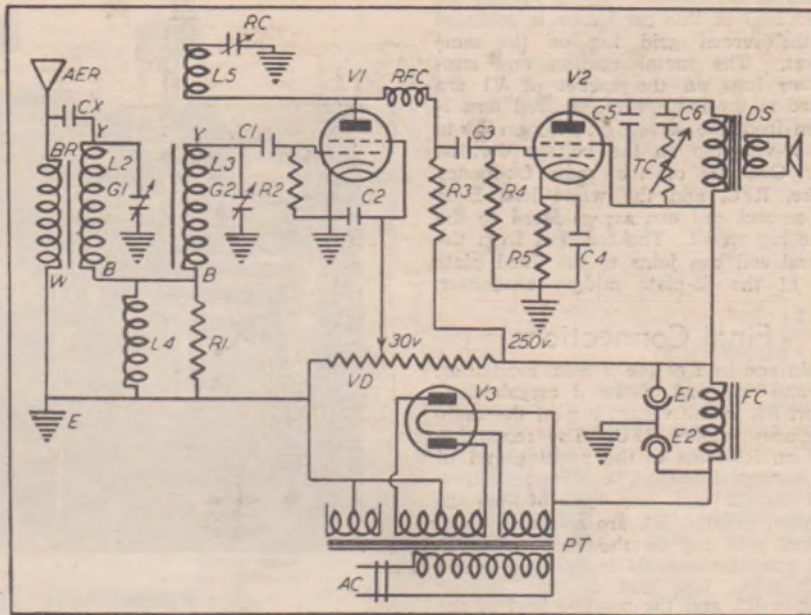

The schematic circuit diagram of "The Mighty Atom" is key lettered to agree with the components list and the wiring instructions.

one filament lug on the rectifier socket for V3. The other filament lug on this socket is wired to the remaining lug on the second four-volt winding on PT. Join one filament lug on V3 to the

positive lug on the first electrolytic condenser, E2, and to one of the field winding lugs on the l.s. socket. The other field winding lug on this socket joins to one of the input transformer lugs on the same socket, to the screening grid lug on the socket for V2, to the positive lug on E1, and to one end of the voltage divider, VD.

Join one of the outside 400-volt lugs on PT to one P lug on the socket for V3, and join the other P lug on this socket to the remaining outside 400-volt lug. To the high-voltage centre tap lug on PT solder a bare tinned copper wire, joining this to the free end of VD, to a lug held under the securing bolts of the sockets V1 and V2, to the earth terminal on the chassis, and to the moving plate lug on the midget condenser, RC. This constitutes the earth wire, to which leads must be soldered from various other components in the receiver.

Next, solder the braided lead from the AER coil to the aerial terminal on the chassis and solder the white lead from this coil can to earth. The black lead to this can and the lead of the same color should be soldered to one lug on the coupling coil, L4. The same lug on L4 should carry one lead of the 25,000 ohm resistor, R1. The other lead of R1, and the remaining connection on L4, join to the earth wire. The yellow lead from the AER coil can joins to the fixed plate lug on the G1 section of the gang condenser. The yellow lead on the second coil can joins to the fixed plate lug on the G2 section of the gang condenser, whilst a second lead is taken through the bottom of the coil can to solder to one lug on the .00025mfd. condenser C1. The other lug on C1 and one lead on the 2 megohm resistor R2 are joined to the grid clip which connects to the grid of V1.

The other end of R2 and the cathode lug of V1 join to the earth wire. One lead of the .5 mfd. condenser, C2, is

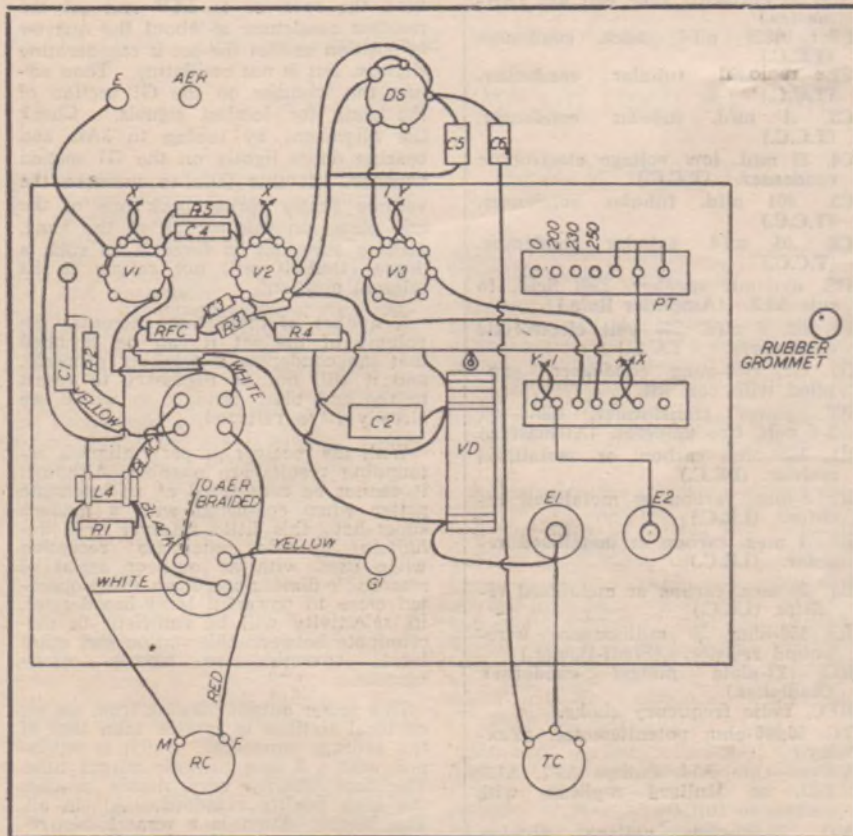

For the novice! This point-to-point-wiring diagram shows the connections of the receiver as viewed from the underside of the chassis.

joined to the cathode lug on V1 and the other lead of this condenser is soldered to the screen grid lug on the same socket. The metal coating and suppressor lugs on the socket of V1 are joined to the earth wire. A lead now is taken from the screen grid lug on V1 to the 30-volt tap on the voltage divider, VD. One lug of the radio frequency choke, RFC, and the white lead from the second coil can are soldered to the plate lug on V1. The red lead from the second coil can joins to the fixed plate lug of the 23-plate midget condenser, RC.

Final Connections

Join one lead of the .1 mfd. condenser, C3, and one lead of the .1 megohm resistor, R3, to the vacant lug on the radio frequency choke, RFC. The remaining lead on R3 joins to the positive end of the voltage divider, VD. The remaining lead on C3 and one lead of the .25 megohm resistor, R4, are soldered to the control grid lug on the socket for V2. The other lead on R4 is soldered to the earth wire. One lead of the 150 ohm resistor, R5, and the positive lead of the 25 mfd. electrolytic condenser, C4, are soldered to the cathode lug on the socket for V2. The remaining leads on these components join to the earth wire. To the screening grid lug on V2 socket solder one lug of the .004 mfd. condenser, C5, and one outside lug of the tone control resistor, TC. The remaining lug on C5, one lead of the .05 mfd. condenser, C6, and the remaining input transformer lug on the 1.s. socket all are joined to the plate lug on the socket for V2.

The vacant lead on C6 is joined to the centre lug on TC. The wiring of the receiver is completed by soldering the supply leads to the correct lugs on the primary of PT.

Having completed the wiring, the next job is the alignment of the receiver. In their commercial form the iron cored coils have the cores sealed into them so that no adjustment to this portion of the tuning system is necessary. The coupling condenser, CX, also is sealed. Thus the alignment of the receiver comes down merely to a question of setting the trimmer condensers of the gang condenser at such a value that both sections of the gang are in step at the bottom end of the band.

Provided that the gang condenser has been properly aligned by the manufacturer, and that it has not been mishandled by the set constructor, it will be found to track perfectly throughout the range.

Another point which requires attention with the specified gang condenser is the trimmer condensers. It may be found that the trimmers cannot be opened up far enough to "get down" to 3AK or other stations operating on 200 metres. The cause is that the anchored end of the trimmer condenser movable plates bear heavily against the mica separator, with the result that a fairly high residual capacity exists even when, the trimmer is apparently "wide open."

To remedy this unscrew the adjusting screws on the trimmers, remove the mica sheets, and very carefully lever the moving plate of the trimmer up from the bottom so that it permits the mica easily to be slipped back into place.

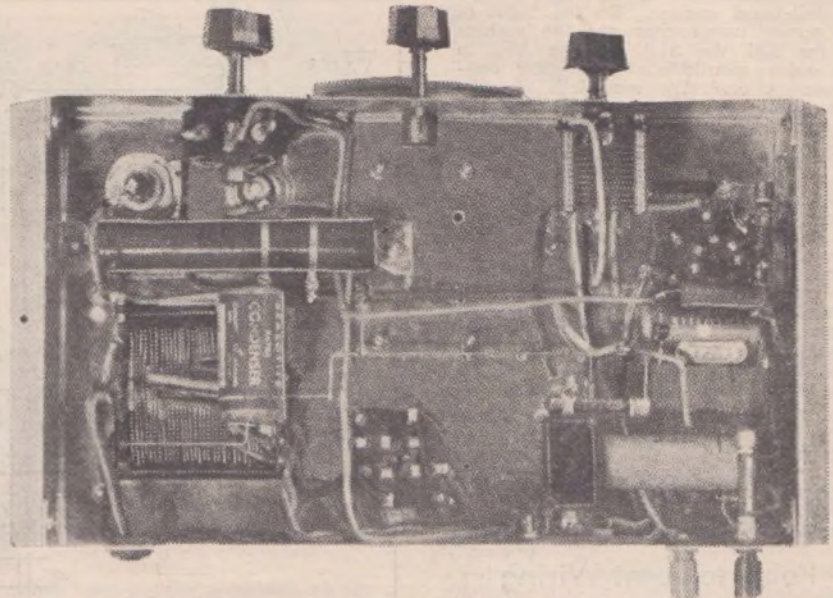

This under-chassis view of the receiver should be studied in conjunction with the plan wiring diagram.

THE PARTS LIST

Chassis measuring 12 inches by 7 inches by 2½ inches.

Special Ferrocart type coil kit. (Airmaster.)

C1, .00025 mfd. mica. condenser (T.C.C.)

C2, .5 mfd. tubular condenser. (T.C.C.)

C3, .1 mfd. tubular condenser. (T.C.C.)

C4, 25 mfd. low voltage electrolytic condenser. (T.C.C.)

C5, .004 mfd. tubular condenser. (T.C.C.)

C6, .05 mfd. tubular condenser. (T.C.C.)

DS, dynamic speaker, 2500 field, to suit AL3. (Amplifier Rola.)

E1, E2, 8 mfd. 500 volt electrolytic condensers. (T.C.C.)

G1, G2, two-gang condenser, supplied with coil kit.

PT, power transformer, 400-0-400, 2-4 volt, two amperes. (Airmaster.)

R1, 2500-ohm carbon or metallised resistor. (I.R.C.)

R2, 2-meg. carbon or metallised resistor. (I.R.C.)

R3, .1 meg. carbon or metallised resistor. (I.R.C.)

R4, .25 meg. carbon or metallised resistor (I.R.C.)

R5, 150-ohm, 50 milliampere wire-wound resistor. (Stedi-Power.)

RC, 23-plate midget condenser. (Radiokes.)

RFC, radio frequency choke.

TC, 50,000-ohm potentiometer. (Yaxley.)

Valves—One each Philips AF7, AL3, 1561, or Mullard replicas, with sockets to suit.

VD, 15,000-ohm voltage divider. (Radlokes.)

If this is done carefully no harm will result to the condenser and the set, will tune over the desired range from above 1500 k.c. to about 560 k.c.

In making the alignment adjustments tune the receiver to 3XY and set the reaction condenser at about the quarter in position so that the set is regenerating slightly, but is not oscillating. Then adjust the trimmer on the G1 section of the gang for loudest signals. Check the alignment by tuning to 3AR and bearing down lightly on the G1 section trimmer. If this fails to increase the volume gently spring back one of the end plates on this section of the gang, making sure not to force it to such a degree that it will not return to its original position.

If neither of these tests increases the volume of the set it can be assumed that the condenser is tracking properly, and it will not be necessary to resort to the end plate bending to which we already have referred.

With the receiver properly aligned, astounding results are possible. Although it cannot be considered as an interstate getter when compared with a modern super-het., this little receiver will definitely provide interstate reception when used with an outdoor aerial of reasonable dimensions. Even when operated close to powerful local broadcaster, its selectivity will be sufficient to discriminate between this station and other locals operating on nearby wavelengths.

This power output possible from the set on local stations is greater than that of the average super-het., which is equipped with a 3 watt pentode output tube. The tone quality very nearly reaches the high fidelity standard. All in all, The Mighty Atom is a remarkable receiver and the outstanding two valve receiver of the hundreds which have yet been described.

THE PRE-SELECTED UNIVERSAL SUPER-HET

A photograph of the completed assembly. Only three controls are required to operate this receiver. They are (left) the tone control (centre) the main tuning control and (right) the volume control.

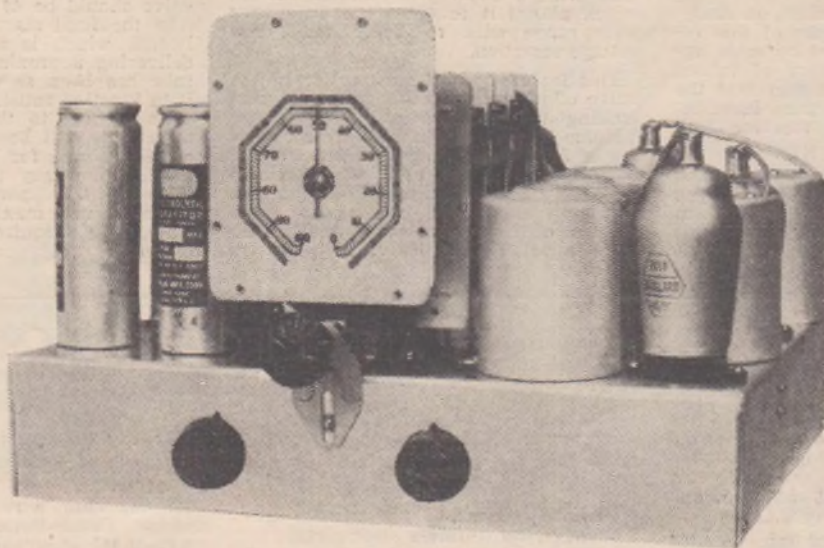

The receiver is built on an aluminium chassis and employs the latest type universal tubes. Owing to the high gain of these valves, it was found necessary to shield the grid leads as shown in this photograph.

A Highly Sensitive Five Valve Universal Receiver which is adaptable for Operation on both AC and DC Mains

By P. R. DUNSTONE

BRITISH and Continental valve manufacturers have apparently worked along different lines to those followed by the Americans. Although the basic principles of the craft have been followed by both groups, the first mentioned has concentrated mainly on the development of high efficiency valves. Considerable attention also has been given by them to the development of special purpose valves.

Prior to the arrival of the English and Continental type of AC/DC radio receiving valves, set designers were forced to use series filament resistance to dissipate the excess voltage. This presented many difficulties, inasmuch that when the radio chassis was housed in a cabinet of restricted dimensions it became difficult to dissipate the heat generated by the series resistance. Another drawback to this method was that of variation in the line voltage.

Both difficulties have been eliminated with the AC/DC series. In place of a series resistor, a "Barretter," or Iron Regulating Lamp, which permits a continuous flow of 0.2 amperes, has been designed.

The receiver which we propose to describe in this article is a five-valve super-heterodyne. It employs a pre-selector stage in front of the pentagrid valve, which is used as the modulator and oscillator, one stage of intermediate frequency amplification, an anode bend

second detector, and a pentode audio-frequency output stage.

Before dealing with the constructional details we will give a brief explanation of the heater and power side of the receiver, as this section is actually the only departure from the standard run of super-heterodyne circuits. It is possible that this section will appear a little involved to the inexperienced radio enthusiast.

Referring to the schematic circuit diagram of the receiver, it will be seen that the order of wiring the filaments in series is unusual. The second detector, SP13, is connected at the lowest potential in respect to chassis, and is followed by the modulator valve, FC13, the intermediate frequency amplifier, SP13A, the rectifier, UR2, and, finally, the pentode output valve, PEN26. It is important that this order of wiring is followed in order to obtain a humless output from the set.

Although we have mentioned that the barretter replaces the series filament resistor, many readers may be a little doubtful as to what part this regulating lamp plays in the heater system. In order to thoroughly understand the principle of this lamp we will study the requirements of these tubes. The volt-

age requirements for these valves differ with the various types. The FC13 requires 13 volts, while the rectifier needs a potential of 30 volts. It will be best at this juncture to completely disregard the voltage side and study the current. Now, in order to allow their rated current flow of 0.2 amperes to flow in the filament circuit, it will be necessary that a potential of 93 volts be developed across the complete set of tubes in the receiver, and it is at this point where these Universal tubes are superior to other types. Since the receiver is designed to be operated on either AC or DC mains which are ranging from 200 to 260 volts, it is obvious that a voltage of 107 to 167 volts must be dissipated. Here the barretter plays its part, as this regulating lamp is so designed as to dissipate or absorb all voltage in excess of that required by the actual filaments of the valves used, with the result that only the desired current of 0.2 amperes is allowed to flow through the heaters of the valves. In addition to this feature these tubes are electrically flexible, and any voltage variation, within reason, in the supply lines, will not seriously interfere with the functioning of this receiver.

When the receiver is operated on the D.C. mains it will be necessary for the power leads from the set to be connected to their correct sides of the mains (i.e., the positive leg of the mains to the positive side of the power input socket MP, and the negative side of the mains to

the negative side of the receiver), otherwise it will be found that although the filaments of the valves light, the rectifier UR2 will not pass any current until the correct polarity is obtained.

In the case where the receiver is operated on AC mains this condition does not exist. The rectifier then will function as an ordinary half-wave rectifier, delivering a pulsating DC current output which will in turn be smoothed by the filter network which consists of a 30 henry 120 milliampere choke and two 8 mfd electrolytic condensers.

The average radio enthusiast, on studying the original photographs of this receiver, may be discouraged by what appears to be a large number of valves. This is mainly due to the fact that the extra socket containing the barretter will tend to make the receiver look larger than it actually is.

The valve FC13 is a standard pentagrid converter, and is similar to the 2A7 type tube which is so widely used in modern AC operated super-heterodynes. This valve is an eight electrode tube, and has

been primarily designed for operation as a modulator and oscillator in Universal receivers. It is important when using this converter tube, that the voltages for the plates and screen be correctly adjusted. The plate of the pentode section should receive 180 volts, which is the maximum obtainable voltage when operated from 230 DC, whilst the screen and the oscillator plate should both receive 70 volts.

The next valve in the circuit is the VP13A, which is a variable mu R.F. pentode with a short grid-base or cut-off, which allows it to operate over a very wide range with relatively small bias voltage variation.

This feature in the construction of the valve offers an admirable means of controlling the volume of the receiver. Volume control is obtained by connecting a 2500 ohm potentiometer in the cathode lead of the tube, which is also taken to a 20-volt tapping on the voltage divider. The valve requires a plate voltage of 180 volts, while the screen needs a potential of 100 volts.

In the second detector we have used the SP13, which is a standard screen grid tube, adaptable for RF, detector and audio frequency work. In this circuit we have used the tube as an anode bend detector. When used under these conditions, the recommended plate load resistance is .3 megohms, while the screen o. the tube should be fed through a potentiometer or voltage divider. When operating the SP13 as an anode bend detector with the maximum voltage applied to the plate through a .3 megohm resistor and a cathode resistance of 10,000 ohms, the screen voltage for this valve should be 40 volts.

In the final stage, we have used the PEN26, which is a pentode capable of delivering approximately 3 watts. This tube has been so designed as to allow it to function satisfactorily with only 100 volts applied to the plate, and at the same time still be capable of supplying ample volume for the average requirements. Contrary to the usual run of pentodes, this particular valve when operated with maximum voltage on the plate, only requires 100 volts on the screen.

LIST OF COMPONENTS AND CIRCUIT DIAGRAM

Required to Build the Pre-Selected Universal Super-Het

- Coil kit—(See text).
- C1, C2, C6—0.01 mfd. fixed mica condensers. (T.C.C.)
- C3, C5, C8, C9, C11—0.1 mfd. fixed tubular condensers. (T.C.C.)
- C4—0.0001 mfd. fixed mica condenser. (T.C.C.)
- C7—0.5 mfd. fixed tubular condenser. (T.C.C.)
- C10—0.001 mfd. fixed mica condenser (T.C.C.).
- C12—25 mfd. 25 volt test electrolytic condenser. (T.C.C.)
- C13—0.04 mfd. fixed condenser. (T.C.C.)
- CH—30 henry 120 m.a. low D.C. resistance filter choke. (Stedi-Power.)

- E1, E2—8 mfd. 600 volt test electrolytic condensers. (T.C.C.)
- G1, G2, G3—Three gang tuning condenser to match coils with dial.
- IF1, IF2—175 k.c. intermediate frequency transformers (see text).
- MP—Marquis A.C. power plug and socket.
- R1—50,000 ohm carbon resistor (I.R.C.)
- R2—350 ohm wire wound 10 m.a. resistor. (Stedi-Power.)
- R3—650 ohm wire wound 10 m.a. resistor. (Stedi-Power.)
- R4—10,000 ohm carbon resistor. (I.R.C.)

- R5—.3 megohm carbon resistor. (I.R.C.)
- R6—500,000 ohm carbon resistor. (I.R.C.)
- R7—400 ohm wire wound 50 m.a. resistor. (Stedi-Power.)
- TC—20,000 ohm variable resistance. (I.R.C.)
- VC—2500 ohm potentiometer.
- VD—25,000 ohm voltage divider.
- Valves—FC13, VP13A, SP13, PEN26 and UR2 with sockets to match. One barretter. (Mullard or Philips replicas.)
- Speaker—Dynamic loud speaker to match PEN26 with field resistance of 7500 ohms. (Amplion, Rola.)

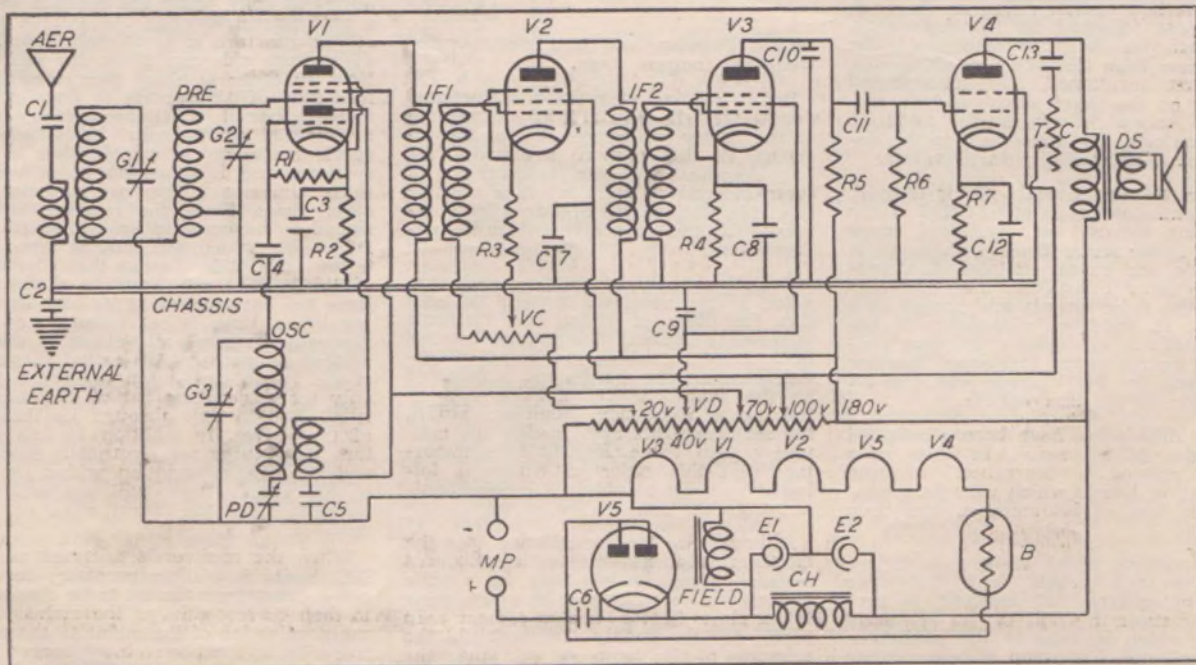



PRE-EMINENT in modern radio design, the Philips Octode has no counterpart in other makes. Like the Penthode, it is an individual achievement of the Philips Laboratories.

The Octode may be incorporated in A.C., A.C./D.C., or battery receiver, with the assurance of finer all round performance, lower noise level, and outstanding shortwave efficiency.

For Better Radio, be sure that the set you buy is Octode equipped.

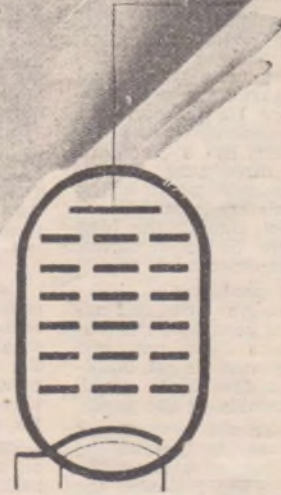

PHILIPS

METAL CLAD VALVES

THERE'S A PHILIPS VALVE FOR EVERY SOCKET OF EVERY RECEIVER

With the exception of the PEN26, all the valves used in this model are of the metal coated type, thus eliminating the necessity of using valve shields in order to prevent interaction or feed-back between the different stages.

The only departure in this receiver from the standard super-heterodyne design, is the Universal valves and the power section of the receiver. The remaining portion of the circuit should not offer any difficulties to the average set builder.

From the aerial, the signal is fed through a pre-selector stage to the grid of the FC13 where it is mixed with the locally generated signal and the "beat" is passed through the intermediate frequency transformer, IF1, to the grid of VP13A. This valve amplifies the signal at a frequency of 175 k.c. and passes it on to the second detector, whence it is de-modulated and fed through the resistance coupling to the grid of the output valve, PEN26. The field of the speaker, which has a resistance of 7500 ohms, is connected direct across the rectified supply. In most cases the field of a dynamic speaker is wired in the positive lead of the power supply and acts as the smoothing choke in addition to receiving its necessary field excitation, but in the case of a set of this type where it is necessary to take advantage of all available voltage the drop which would be caused in placing the field in the positive lead makes this method impracticable. Therefore, a standard low resistance of 30 henry filter choke is used as the smoothing inductance, and the field of the speaker is connected direct across the rectifier.

In this design consideration should be given to the intermediate frequency transformers. The choice of 175 k.c. intermediate frequency was made in preference to the 465 k.c. in order to secure the maximum gain from the receiver.

The coil kit is of standard design and consists of one aerial coil, one pre-selector filter coil, and one 175 k.c. oscillator coil with padder condenser to match. These coils are tuned by a standard Stromberg-Carlson three gang tuning condenser. It is important when wiring the coils that all leads are kept as short as possible, otherwise, due to the high gain obtained from the Universal valves, instability will be experienced.

The accompanying photographs showing the finished receiver are self-explanatory, but, for the benefit of amateur radio enthusiasts who have not had much previous experience in set building, we will give a few hints which will assist in the assembly of the parts.

The valve sockets should be arranged in such a manner as to permit the heater leads to be carried around the sides of the chassis. When fastening the sockets to the aluminium chassis, it is advisable to place soldering lugs beneath the mounting screws. This will allow a common earth wire to be carried throughout the set and thus ensure perfect electrical "earth" at all positions on the chassis.

It is important that the aerial and earth terminals which are mounted on the rear side of the chassis are well insulated from the aluminium, and that the condensers which are connected between the external aerial and earth terminals are of high test. This precaution will prevent any likelihood of receiving a shock should a component in the receiver break down and short-circuit to chassis.

Particular care should be taken when making external earth connections to the

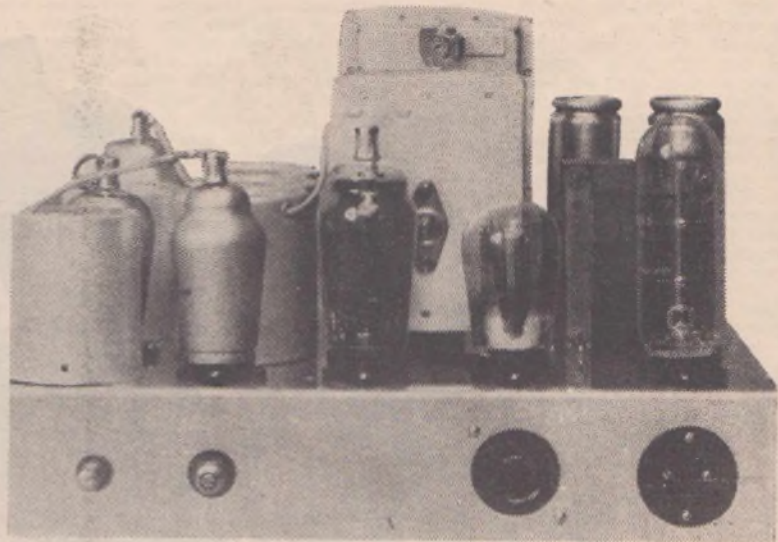

The rear view of the chassis depicts the mounting positions of the aerial and earth terminals, the dynamic speaker, input socket and the power inlet.

receiver as it MUST be realised that the aluminium chassis is "alive" in respect to earth.

When mounting the three gang tuning condenser, G1, G2, G3, care should be taken to see that it is placed sufficiently far back on the chassis to allow the mounting of an aero full vision dial, so that the face of the dial will be flush with the front of the chassis.

With the exception of the voltage divider, all parts below the chassis are wired directly into circuit and rely upon their "pig-tails" to hold them rigidly in position. Before commencing the wiring of this receiver, we will mention the various leads which must be shielded with metal braided wire, the braid being earthed.

The leads are:—The three grid leaks, which include the modulator tube, the intermediate tube, the second detector. The plate and "B" positive leads from the two intermediate frequency transformers.

Wiring in Words

Commence the wiring by running a tinned copper wire around the various soldering lugs mounted below the valve sockets, and continue the wire through the condenser, C2, to the earth terminal mounted at the rear of the chassis. This wire will act as the common earth lead for all necessary connections.

Take a lead from the aerial terminal on the aerial coil and join it to the aerial terminal at the rear of the chassis through condenser C1. The other end of this aerial coil is taken to earth. The top of the secondary winding on the aerial coil former is soldered to the fixed plates of G1 section of the three gang tuning condenser. The end of the secondary winding on AER is connected to the tap on the pre-selector coil, whilst the beginning of PRE is joined to the fixed plates of G2 section of the gang and to the grid pip on top of V1. The remaining terminal on PRE is taken to the common earth wire.

The plate terminal of the modulator portion of V1 is joined to the P terminal on IF1, whilst the "B" terminal on IF1 is taken to the maximum tapping on VD. The plate terminal of the oscillator portion of V1 is soldered to the P terminal on the oscillator coil, and a lead is

taken from the other end of this winding, and the screen terminal on V1, to the 70 volt tapping on the voltage divider, VD. This lead is by-passed by condenser, C5, to earth.

The grid terminal of the oscillator portion of V1 is connected through condenser, C4, to the start of the grid winding on OSC. Another lead is also taken from this point to the fixed plates of the G3 section of the three gang condenser. The other end of the grid winding on the OSC former is connected to one side of the padder condenser, and the other side of PD is taken to earth.

A grid leak is soldered from the grid of the oscillator portion of V1 to the cathode terminal on the same socket.

One end of resistor, R2, and the condenser, C3, should be soldered to the cathode terminal on V1. The other ends of these components are taken direct to earth.

The suppressor grids in V1, V2 and V3 should be taken to the cathode terminals on their respective valve sockets, whilst the terminal which is connected to the metal coating on the outside of the tubes is joined direct to earth.

The G terminal on IF1 is fastened to the control grid on the top of V2, whilst the other end of this winding is taken to earth. The plate terminal on V2 is connected to the P terminal on IF2 and the "B" terminal of the winding is taken to the maximum "B" supply.

The cathode terminal on V2 is soldered to one end of R3. The other end of this resistor is joined to the movable arm of VC. One of the outer terminals on VC is taken to earth whilst the other side of the resistance is connected to a 20 volt tapping on the voltage divider.

The screen grid terminal on V2 is taken to the 100 volt tapping on the voltage divider, and is by-passed by the condenser, C7, to earth. The G terminal on the secondary of IF2 is taken to the control grid on top of V3, and the other end of this winding is taken to earth. One side of C8 and R4 are soldered to the cathode terminal on V3 valve socket and the other ends of these two components are taken to earth.

The plate terminal on V3 socket is fastened to one side of C10 and to one end of R5 and C11. The other side of C10 is joined direct to earth.

The screen terminal on V3 valve socket is soldered to a tapping on the divider which will supply 40 volts. This lead is by-passed by condenser C9 to earth.

The remaining end of R5 is taken to the maximum "B" supply. The other side of C11 is fastened to one end of R6 and to the control grid on top of V4. The vacant end of R6 is taken to earth. The cathode terminal on V4 valve socket is soldered to one end of C12 and R7, whilst the other ends of these two components are taken to earth. The screen terminal on V4 is connected to the 100 volt tapping on the voltage divider, VD. The plate terminal on V4 socket is joined to what is normally the P terminal on the speaker input socket, and the grid terminal on the speaker input socket is taken to the maximum end of VD.

The tone control, consisting of C13 and TC, is wired between the plate terminal on V4 socket and earth.

This leaves only the power and heater section of the receiver to be wired.

Commence this portion of the circuit by taking a lead from the common earth wire to one of the filament terminals on V3 socket. Proceed to wire the sockets in the order shown in the circuit diagram, finishing with the barretter, which has one side connected to the positive terminal on MP.

The negative terminal on MP is taken direct to the common earth wire. Another lead is taken from the positive side of MP and soldered to one side of C6, and to the two-plate terminals of V5 socket, whilst the other side of C6 is fastened to the two cathode terminals on V5 socket to the positive side of E1, to one side of CH, and to one of the filament terminals on the dynamic speaker input socket.

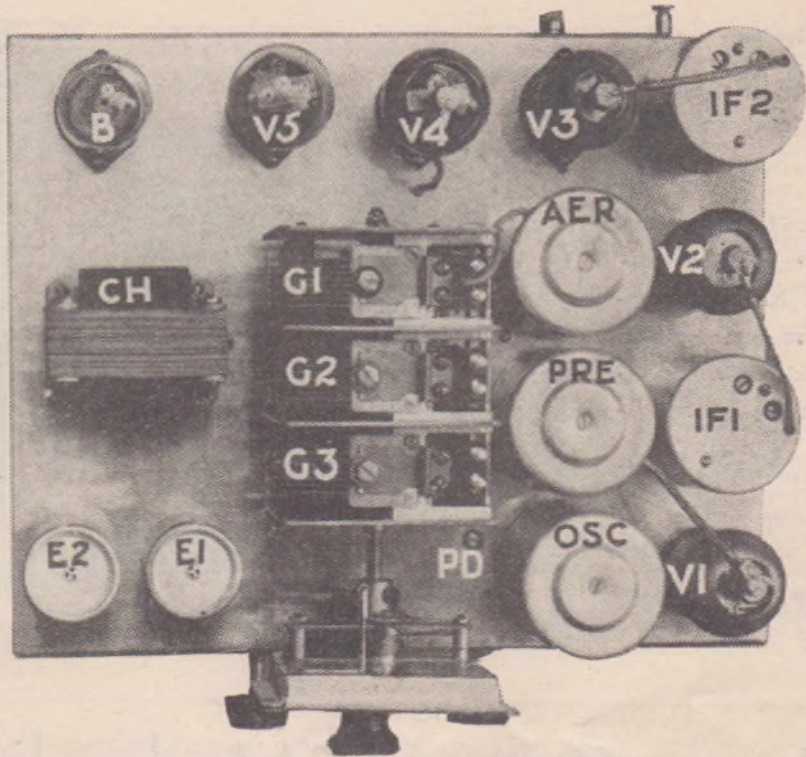

This view of the set shows the mounting positions of the various components on top of the chassis. All parts are keyed to correspond with the written description of the receiver.

The remaining terminal on this socket is connected to earth.

The other side of CH is taken to the positive side of E2 and to the maximum end of VD, whilst the other end of VD is connected to earth.

Final Adjustments

Having re-checked the wiring of the receiver with the circuit diagram accompanying this article, connect the aerial and earth to their respective terminals on the rear of the chassis, plug in the dynamic speaker and switch on the power and allow the valves to warm. The heating of the valves will take approximately two minutes. Now adjust the tapplings on the voltage divider to correspond with the voltages shown on the circuit diagram.

When the receiver is operating the tuning and the i.f. stages may be aligned in the usual manner.

When the receiver is operated in an average receiving locality no difficulty should be experienced in the logging of a number of interstate stations at good loud-speaker strength.

Should the receiver be operated in areas where the mains are noisy it would be advisable to include a line filter in between the power lines and the actual set, as it must be understood that the receiver is connected direct to the mains and a "noisy" supply will obviously be reproduced in the reception.

When under test it was found that this receiver was practically humless. Provided that all directions given in this article are closely followed, the builder should not experience any difficulty in putting this circuit into operation. Its performance will be found to equal in every way that of a similar type a.c. receiver, whilst its flexibility of design permits it to be used in almost any city or country town.

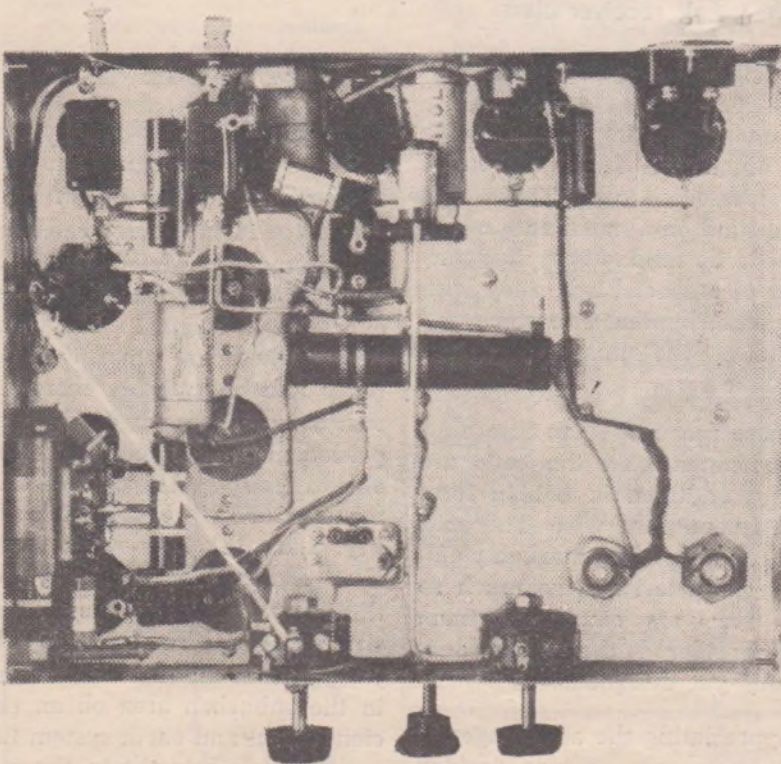

An underneath photograph of the Universal receiver, showing the wiring and placement of parts.

This illustration shows that attractive layout has been combined with technical efficiency in this interesting battery design.

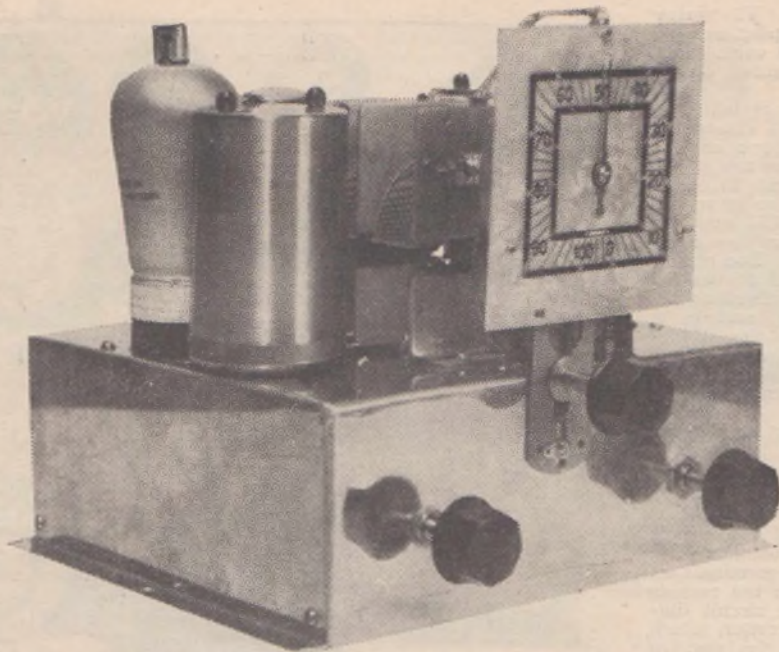

The three controls fitted to the receiver are (left) the reaction control, (centre) the main tuning control, and (right) the volume control.

The Iron-Cored Melodious Three

The remarkable efficiency of the new iron dust-cored coils has been combined with the high gain of the latest types of battery valves to make this receiver an outstanding performer in the small receiver class.

By H. R. SETFORD

LAST year we designed the Melodious Three, at that time the most modern battery receiver designed.

The success of this outstanding receiver was instantaneous, and many congratulatory letters were received setting out the wonderful results obtained by the builders of the receiver.

It was estimated that over 300 kits of parts for this receiver were sold to experimenters in Victoria alone, not to mention the number sold by dealers to people in the outback country areas.

Another feature of this remarkable receiver was its extremely economical battery consumption. Many reports have reached us of instances where the "B" batteries have been in use for 12 months and even longer.

Remarkably improved results are obtainable from the latest type iron-cored coils. These coils are wound on a metal core which is made by mixing very fine particles of a special iron alloy with a ceramic binding substance and moulding the mixture into a tube-like form.

These forms are cut into suitable lengths, and the coils are wound on them in bobbin form with Litzendraht wire. The coils so wound possess remarkably efficient characteristics, so much so that receivers employing them are considered the most satisfactory yet designed.

Appreciating the advantages of these new coils, it was decided to build an ultra-modern battery receiver. The success of the

Melodious Three led to the new receiver being designed on very similar lines. The receiver in its completed form is described here. The iron-cored Melodious Three possesses two great advantages over the original Melodious Three. These are amazing selectivity and enormously increased sensitivity. These two great improvements are directly attributable to the special iron-cored coils manufactured by "Radiokraft" Pty. Ltd., 131 Brunswick Road, East Brunswick, especially for this receiver. The wonderful sensitivity of the receiver may be judged from the fact that in tests in the suburban area on an efficient aerial and earth system this receiver has brought in the majority of Australian stations at speaker strength.

THE receiver consists of a stage of radio-frequency amplification followed by a regenerative grid leak detector which is resistance-coupled to a pentode output valve. This arrangement enables more than sufficient sensitivity to be obtained for average country use, while the inherent selectivity of the new type coils ensures a degree of selectivity hitherto unobtainable from small receivers.

The coils employed are of the Crolite type manufactured by Radiokraft Pty. Ltd. The aerial coil is of the high impedance type resulting in substantially constant gain over the tuning range of the receiver, while the design of the R.F. coil is such that excellent gain is obtainable from the R.F. stage.

The valves employed in the receiver are Mullard types. A feature of these valves is the remarkably low current consumption for both plate and filament. A type VP2 variable mu R.F. pentode is employed in the R.F. stage, while a straight pentode, the SP2, functions as the leaky grid regenerative detector.

The output pentode is a PM22A, well known for its high output at low voltages. The leaky grid detector is resistance-coupled to the pentode output

valve and the constants have been so chosen that the full grid swing for the output valve is obtained with a very low input to the detector grid.

It will be noticed that, although a variable-mu pentode is used in the R.F. socket, no attempt has been made to control the volume of the receiver in this stage. It may be thought from this that a straight pentode could be used, but, due to the immense pick-up from some of the higher-powered stations, cross-modulation would be certain to occur. For this reason the variable-mu type valve has been used.

Automatic bias is used in the receiver as this obviates the necessity for a separate "C" battery with its subsequent replacements and more complicated battery connections. The total "B" battery consumption of the receiver is milliamperes at 90 volts "B" supply and 8 milliamperes at 135 volts. The filament consumption is low, .56 of an ampere for the three valves.

The signal energy is fed to the grid of the R.F. valve through the aerial coil, L1-L2. The amplified signal appearing at the plate of the R.F. valve is fed through the coupling condenser contained in the R.F. coil to the tuned sec-

tion of this coil and thence to the grid of the detector valve. The demodulated output of this valve feeds the grid of the output pentode via the resistance coupling unit consisting of R2, C4, and R3. The pentode grid resistor is connected to one side of the fixed bias resistor, R4. The resistance of this unit has been so calculated that the correct bias for the PM22A is developed across it, and this negative bias is fed to the grid through the grid resistor. Slight tone compensation was found necessary to rid the receiver of the hiss peculiar to the operation of the pentode. This compensation takes the form of the condenser, C6, which has a capacity of .004 mfd.

The Components

The chassis may be of aluminium or other suitable material. The heart of the receiver is the tuning coils and the gang condenser. These should be as specified if the results obtained with the original model are to be duplicated.

These coils are supplied complete in cans with leads attached, and the wiring description refers to the color code for these particular coils. If another make of coil is used this color code will not hold good.

PARTS LIST AND SCHEMATIC CIRCUIT DIAGRAM of The Iron-Cored Melodious Three

Chassis measuring 8 inches by 7½ inches by 3 inches.

Coil kit consisting of aerial and R.F. coils, Crolite iron dust type. (Airmaster).

- C1.—.0025 mfd. mica condenser.
- C2.—.1 mfd. tubular condenser.
- C3.—.0001 mfd. mica condenser.
- C4.—.02 mfd. condenser.
- C5.—25 mfd. low voltage electrolytic condenser.

- C6.—.004 mfd. condenser. (All T.C.C.)
- G1, G2.—2-gang condenser.
- LS.—Permagentic speaker to suit 22A. (Amplion. Rola).
- M.—23-plate midget condenser.
- R1.—2 megohm resistor.
- R2.—250,000 ohm resistor.
- R3.—500,000 ohm resistor.
- R4.—500 ohm resistor to carry 25 milliamperes. (All I.R.C.)
- R.F.C.—Radiofrequency choke.

Sockets—2 6-pin, 1 5-pin and one large 7-pin.

SW—S.P.S.T. toggle type battery switch.

Valves — One each SP2, Vp2 and PM22A. (Mullard or Philips replicas).

Sundries—Wiring, flex, nuts and bolts, tinned wire, ½ yard of braided wire, dial to suit gang condenser, 3 knobs, aerial and earth terminals, and a 7-pin heavy battery plug.

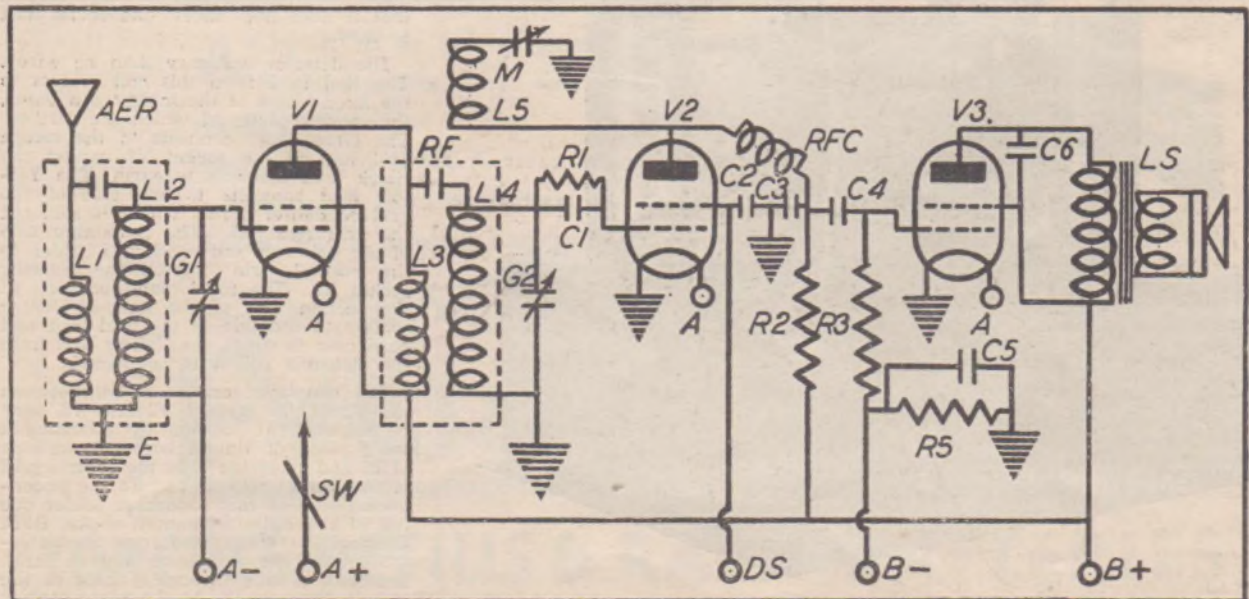

If possible, the gang condenser should be obtained from the same manufacturer, as this ensures perfect matching of these extremely critical components. The fixed condensers used in the receiver should be reliable manufacture. This applies also to the resistors.

Valve sockets which give a firm positive contact to the valve pins should be selected.

The 500-ohm. resistor R4 should be of the wire-wound type, and rated to carry a current of 25 milliamperes. The mid-gang reaction condenser should have no sideplay in its moving plates, and is a 23-plate type. The filament switch should have a "clean," snappy contact, capable of breaking 1 ampere. A faulty switch will cause endless worry in tracing fading signals, and will result in very indifferent reception. The loud speaker for the receiver should be of the permagnetic type matched to suit the PM22 valve. If desired, a magnetic speaker may be used, but results will not compare favorably with the permagnetic type.

Assembly

Having obtained the necessary parts for the receiver, the next step is to assemble them in the position they are to occupy on the chassis. The gang condenser is mounted centrally on top of the chassis, whilst directly behind it is the valve socket for the PM22A pentode. To the right of the gang condenser are mounted the R.F. valve socket and the aerial coil, whilst to the left of the gang condenser the detector valve socket and the R.F. coil are bolted in place.

The exact position of these components can be seen from the plan photograph of the receiver, which has been lettered to agree with this description.

The filament switch and the reaction condenser are bolted to the front of the chassis, the switch being on the right of the main tuning control. On the back of the chassis are the aerial and earth terminals, and the battery input socket, to which is connected the two speaker leads.

This completes the assembly of parts which are bolted directly to the chassis. When bolting the sockets in place, solder-lugs should be placed under the holding bolts to serve as earth connections when the wiring is commenced.

Point to Point Wiring

Commence the wiring by connecting together one filament-lug on each of the three valve sockets and joining them to one contact of the filament switch. The remaining contact of this switch connects at the "A" positive lug on the battery socket. Each of the three remaining filament lugs may be soldered to the earthed solder lugs on the valve sockets, which should then be connected together. The earth terminal also should be soldered to this wire.

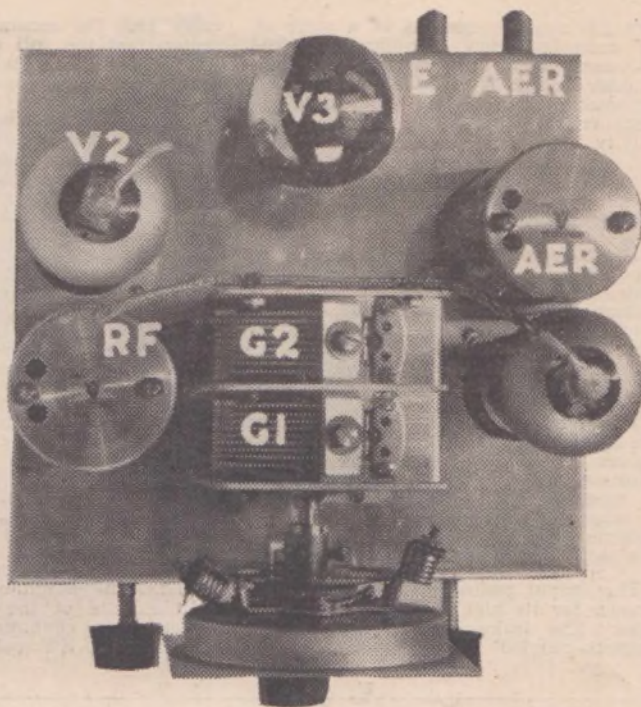

This top chassis view of the finished receiver is key-lettered to agree with the components list and the wiring description.

Solder together the suppressor grid and metal coating lugs on the sockets V1 and V2, and connect them to earth. The coils may then be wired into circuit. The Black and the White lead from the aerial coil solder to the earth wire, whilst the Yellow lead from this coil connects to the control grid lug on the socket, V1. The fixed plate contact of the G1 section of the gang condenser also solders to this lug.

The only remaining lead on the aerial coil is the braided aerial lead. This lead should be cut to the correct length, and the outside metal braid cut back about one inch from the end to make certain that it does not "short" the aerial lead to earth.

The detector coil may then be wired. The Red lead from this coil solders to the fixed plates of the mid-gang condenser, the moving plates of which are earthed. The Green lead connects to the screen grid lug on the socket V1, whilst the Black lead connects to earth. The Yellow lead connects to one side of the grid condenser across which is soldered the grid leak, R1. The remaining side of the gridleak and condenser solder to the control grid lug on the detector socket V2. The fixed plate contact of the section, G2, of the gang-condenser solders to the side of the grid leak and condenser to which the Yellow lead from the detector coil was connected.

The coupling condenser, C4, between the plate and grid of V2 and V3, may be soldered in position by attaching a stout piece of tinned wire to one side of it, and soldering it to the control grid of the PM22A socket, V3. To the unconnected side of this condenser solder one lug of the radio frequency choke, RFC. Connect the White lead from the detector coil to the remaining lug on RFC, and take a lead through a hole in the chassis close to V2, to the plate contact on top of the detector valve V2. Solder

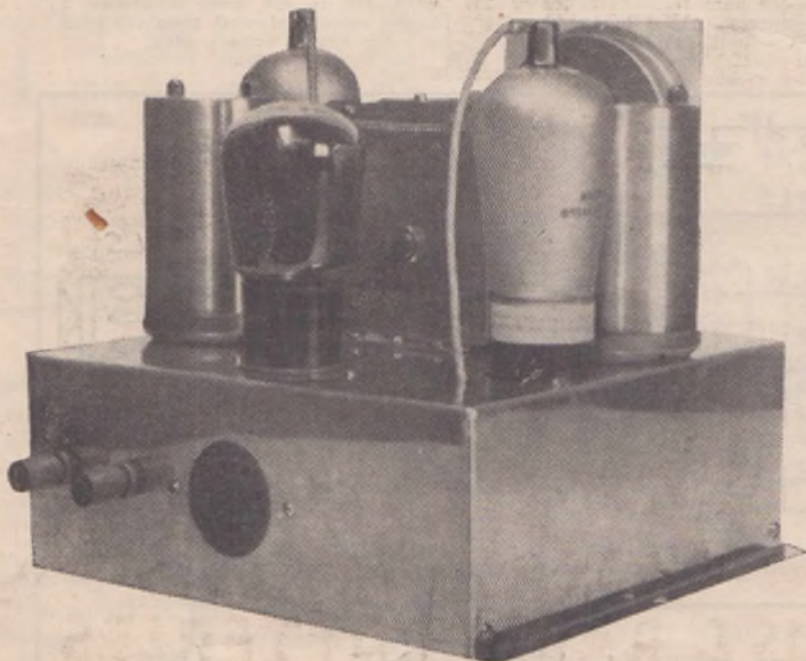

The rear view of the original model illustrates the placing of the aerial and earth terminals and the loud speaker and battery socket.

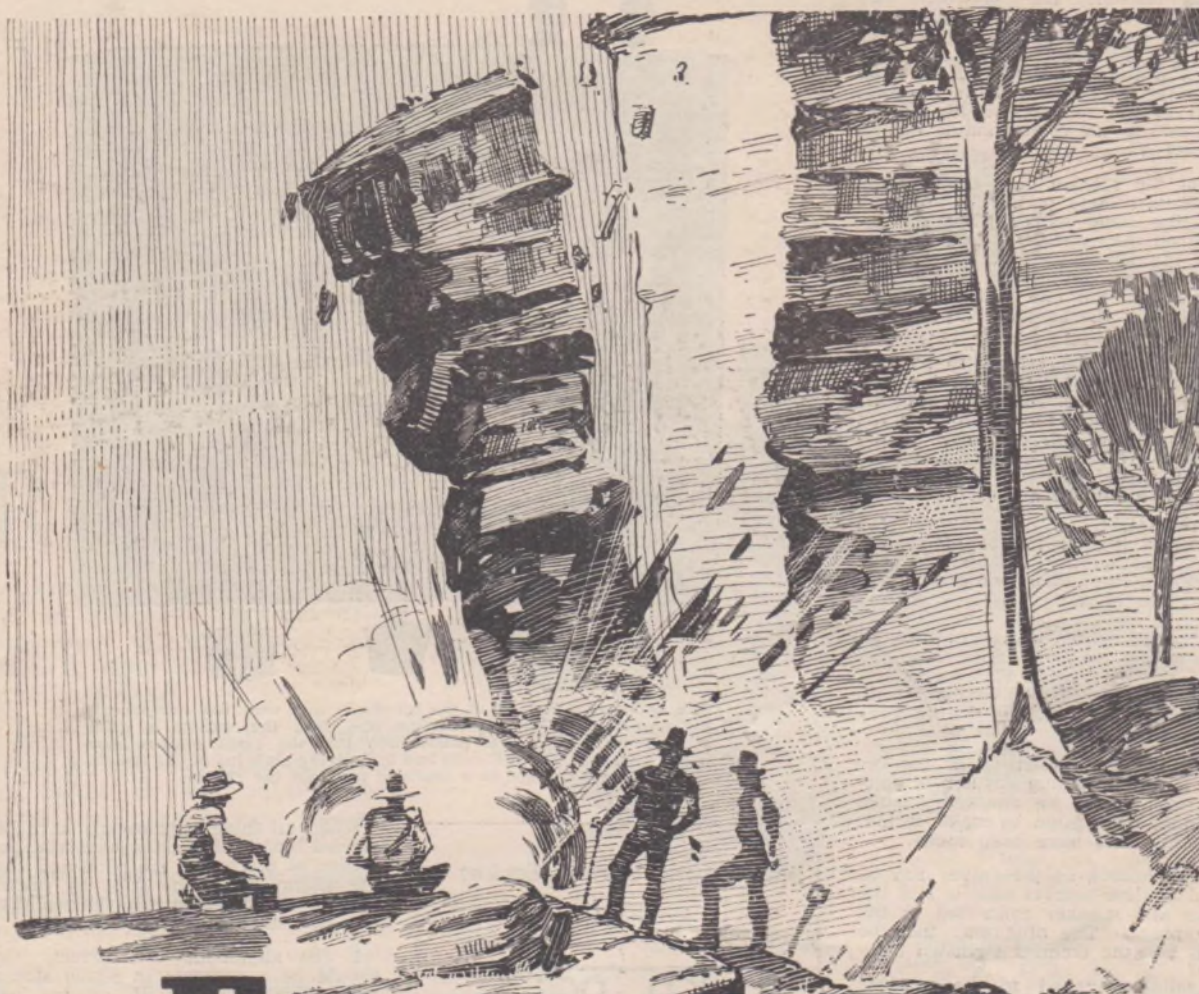

ENERGY

A CHARGE or two of powder, perfectly placed, will fracture a mountain. Energy is power, efficiently and forcibly exerted.

You will find in each Ever Ready Battery you buy a maximum of efficient energy for the operation of your Torch, Radio, or other battery-operated apparatus.



AUSTRALIA'S BEST BATTERIES



TORCHES, REFILLS & RADIO BATTERIES

the bias resistor, R4, between "B" negative lug on the battery socket and earth, and solder the resistor R3, between the "B" negative lug and the control-grid lug of the socket, V3. The "B" positive lug on the battery socket connects to the screen grid lug of the PM22A, and to the corresponding lug on the socket V1.

One of the speaker lugs on the battery sockets solders to the "B" positive lug on the same socket. The screen-grid lug on the detector socket, V2, solders to the DS contact on the battery socket. The remaining lug on the battery socket is the one which connects to the plate of the pentode output valve V3.

The condenser, C6, solders in position across the speaker terminals of the battery socket. Solder one side of the condenser, C3, to earth, and connect the remaining lug on this condenser to the junction of RFC and C4. Condenser C2 solders in place between the detector screen grid lug on V2 and earth.

The resistor, R2, solders between the "B" positive lug on the battery socket and the junction of RFC and C4. The by-pass condenser, C5, connects across the bias resistor, R4.

The braided wire coming out through the top of the R.F. coil connects to the plate of the R.F. valve V1. As before, the metal braid should be cut back from the plate contact of the valve to prevent "shorts."

This completes the wiring of the receiver. Before anything further is done the wiring should be checked against the written description to make certain that no mistakes have been made.

After this check-up the valves may be inserted in their correct sockets and the batteries and speaker connected to the battery plug. The plug may then be inserted and the receiver switched on.

The voltages applied to the receiver are:—90 volts to the "B" positive contact, 67.5 volts to the DS contact and 2 volts to the filaments. If desired, a maximum potential of 135 volts may be applied to "B" positive with slightly improved sensitivity.

The current drains of the receiver at the above plate voltages are worthy of mention.

Operated at 90 volts "B" supply, the drain on the "B" battery was found to be 5 milliamperes — a very low value for a receiver of this description. With the maximum "B" supply of 135 volts the drain increased to 8 milliamperes, a figure which should allow for at least six months' use from the B battery.

The voltages having been adjusted, the aerial and earth wires may be connected and the receiver given an air test.

It should be possible to make the detector valve oscillate with the reaction condenser about half in, and the oscillation should be smoothly controllable over the whole band.

To align the receiver, tune a station at the lower end of the dial, and, with the reaction condenser retarded, adjust the trimmers on the gang condenser for strongest signals. When carrying out this adjustment on no account screw the trimmers right down. The correct alignment should be obtained with the trimmers as far open as possible, in order that the receiver may tune to the highest frequency possible.

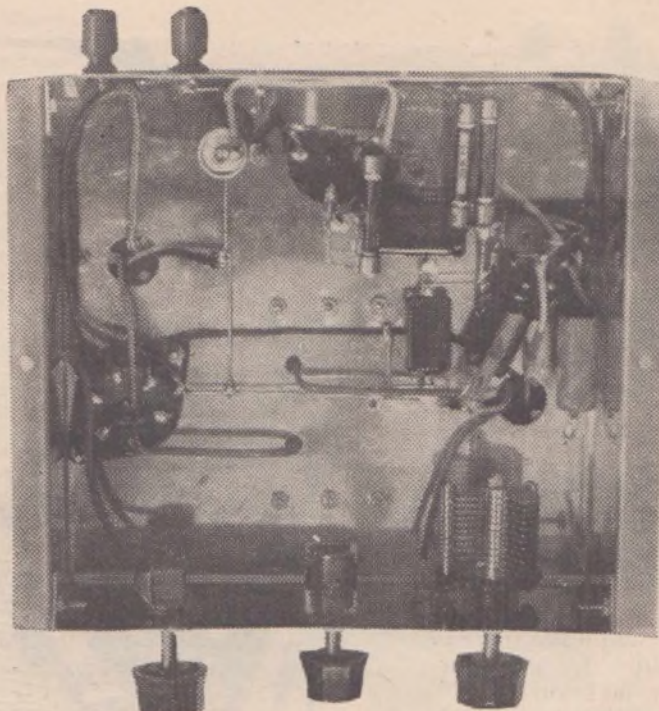

The under-chassis view of the set shows that very few components are required for its construction and that the wiring is quite straight forward. Note particularly that the earth returns from the A.E.R. and the R.F. coils and the moving plate lug of GL and G2 are earthed to a common point on the chassis.

Valve and Battery Socket Connections

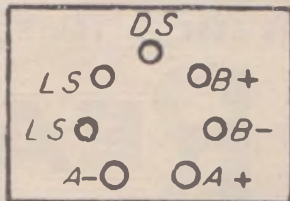
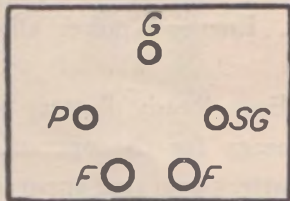
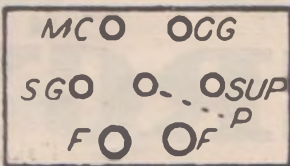

(Top) The connections for the SP2 and VP2 sockets; (centre) the connections for the PM22A socket; (below) the battery socket connections.

When all these adjustments have been carried out, retune the receiver to a station at the top of the band and check the alignment of the gang by pressing down on the trimmers with a pencil or some other insulated object.

If the alignment is correct, there should be a decrease in signal strength when this is done. If, on the other hand, pressing down on the trimmers causes an increase in strength, the alignment should be checked at the lower end and the whole adjustment repeated.

Although these adjustments sound very complicated, they are quite simple, and no difficulty should be experienced in carrying them out.

The results obtained from this receiver are positively astounding even to tried experimenters. Operated in the suburbs on an efficient aerial and earth system, all the interstate "A" and "B" class stations were tunable at excellent speaker strength.

We did not test the receiver in an ideal country location, but, judging from the amazing results in the metropolitan area, country experimenters should have no difficulty in tuning all the Australian stations and possibly several of the New Zealanders.

When the minimum number of parts and the limited battery consumption are taken into consideration, the receiver may be described as one of the best and most modern battery receivers which it has been the writer's privilege to handle. Its simplicity of construction and its ease of adjustment make it ideal for the home constructor as well as for the newcomer to the ranks of radio.

The receiver can be confidently recommended to those who desire to build a sensitive and selective battery set for either city or country use.

The Trans-Ocean Dual-Wave

Full constructional details of a highly sensitive 1936 model dual-wave receiver

By A. K. BOX

RECENT valve and coil developments have had far-reaching effects upon the design of all types of receivers, but particularly so in the case of dual-wave receivers which tune over the short-wave spectrum in addition to the usual broadcast band.

Possibly the most important advance has been that made in the design of the mixer tube. With the manufacture of the octode type of mixer valve the set designer has a tube which is particularly well designed for use in the modern high efficiency super-het. The octode's very low noise level makes it practicable to use very high-gain intermediate-frequency amplifiers after it without raising the background noise to a level at which it will mar reception. The octode possesses another advantage in that it is comparatively free from frequency drift even when the modulator section is subjected to automatic volume control.

THE combination of these improvements makes the modern dual-wave receiver so efficient that its performance shames that of the 1934 and 1935 models.

An example of present-day dual-wave receiver design is furnished by the Radiokes Dual-Wave Trans-Ocean Six, which we shall now describe. This receiver employs a Philips AK2 octode as first detector and oscillator, a 6E5 "electric eye" tube as a visual tuning device, and metal series tubes in all other positions. The metal tubes include the type 6K7 as intermediate frequency amplifier, the 6H6 double diode as second detector and automatic volume control tube, the type 6J7 as high-gain first audio

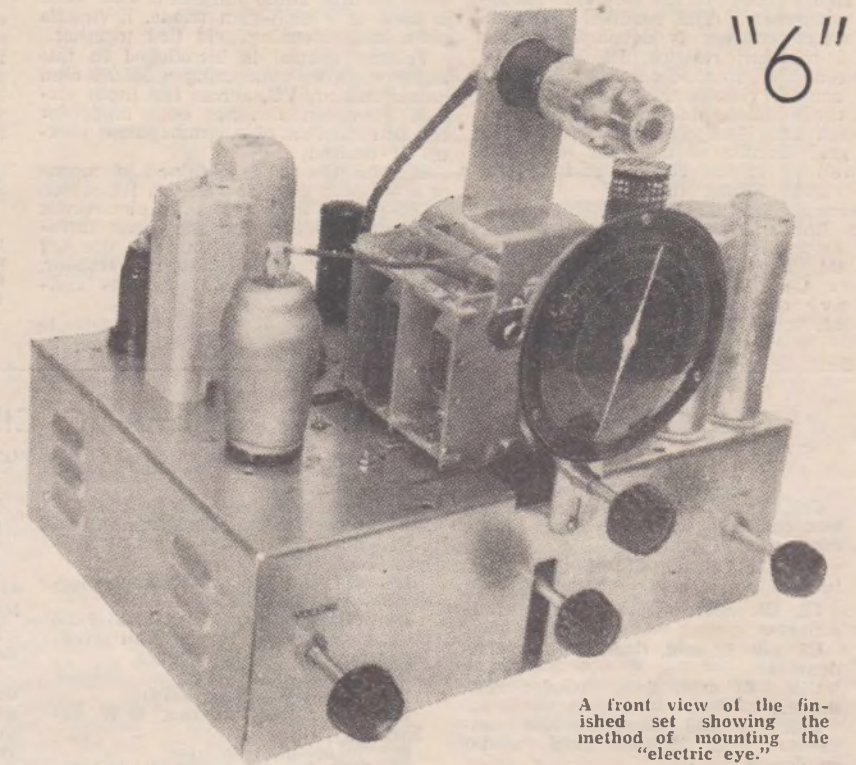

A front view of the finished set showing the method of mounting the "electric eye."

Next we have the recently released metal tubes which combine a high efficiency and low inherent noise level with self-screening, a feature of particular advantage when they are to be associated with high-gain circuits. Another major valve development is the so-called "magic eye," a small cathode-ray type valve which is particularly suitable for use as a visual tuning device.

tube, the metal type 6F6 pentode as the output tube and the metal type 5Z4 as the rectifier.

The receiver is fitted with a coil-box in which are mounted the aerial and oscillator coils for broadcast and short-waves, the trimming and padding condensers for all coils, and the wave-changing switch.

Review of the Circuit

Before touching upon the constructional features of the receiver we first shall review the schematic circuit diagram and deal with the highlights of the set's design. We find that the secondaries of the aerial coil are tuned by the G1 section of the two-gang condensers and that the oscillator grid coils

are tuned by the second, or G2, section of this condenser. The oscillator grid-leak, R2, is a 50,000-ohm resistor and is returned to the AK2 cathode which in turn is biased by means of a 250-ohm resistor provided with a radio frequency by-pass in the form of the .1 mfd. condenser C1.

The oscillator grid condenser has a capacity of .0001 mfd. The coil-switching system and the connection of the trimmers and padding condensers need not be dealt with here because these connections already have been made in the coil-box itself. Suitably-colored coded leads are brought out of the sides of the coil-box for connection to other parts of the circuit. These will be dealt with later when we come to the question of wiring.

The modulator plate of the AK2 feeds into the primary of the first i.f. transformer, which is connected to the high-voltage side of the power-pack filter circuit. The oscillator plate of the AK2 receives a potential of 90 volts from the voltage divider, VD, whilst the screening grid of this tube derives a potential of 70 volts from the same source. Suitable by-pass condensers, C3 and C8, are connected to the screen and oscillator plate supply leads.

The secondary of the first i.f. transformer goes to the control grid of the i.f. amplifier, 6K7. The plate of this tube feeds to the primary of the second i.f. transformer. The screening grid of the 6K7 receives a potential of 90 volts from VD. One of the diodes of the 6H6 is used as the signal diode, and is connected to the secondary of 1F2.

The diode load resistor, R7, has a resistance of 1 megohm, and is joined between the secondary of 1F2 and earth. R7 is by-passed by the .0001 mfd. condenser, C6. The second diode of the 6H6 is the automatic volume control diode, and derives an r.f. potential from the signal diode via the .001 mfd. coupling condenser. The rectified potential for a.v.c. purposes is developed across the 1 megohm resistor, R8, connected between the a.v.c. diode and ground. The control voltage is picked up from the diode plate side of R8, and fed through the 1-megohm resistor, R6, to the grid circuits of the AK2 and 6K7, as well as to the control grid of the 6E5 visual tuning tube.

Decoupling is introduced between the a.v.c. line and the control grid of the 6K7 by means of the .1 megohm resistor, R4, and the .1 mfd. by-pass condenser, C4. It will be seen then that full a.v.c. control is applied to the mixer and i.f. tubes.

Receiver's Audio Section

We come now to the audio side of the receiver. Here we find that the rectified voltage from the signal diode is fed through the .02 mfd. condenser, C7, to the control grid of the 6J7 pentode used as first audio amplifier. This tube is used as a high-gain triode, having its plate and screening grid tied together.

Volume control is introduced in this audio stage by connecting a 500,000-ohm potentiometer, VC, across the input circuit. Provision also has been made for the introduction of a gramophone pick-up, if desired.

Bias for the 6J7 is obtained by means of a 400-ohm cathode resistor, R9, which is by-passed with a 25 mfd. electrolytic condenser. Decoupling has been introduced in the plate circuit of the 6J7 by means of the 50,000-ohm resistor, R11, and the .25 mfd. by-pass condenser, C12.

The grid plate of the 6J7 is coupled to

the control grid of the 6F6 pentode through the .02 mfd. condenser, C9. The .5 megohm resistor, TC, is of the potentiometer type, and has a .01 mfd. condenser connected in series with its arm so that the combination acts as a tone control.

Bias for the 6F6 is obtained by means of what is known as the "back-biasing" system in which the grid resistor, TC, is returned to the centre-tap of PT, which earths to chassis through the 275-ohm resistor, R12. The voltage developed across R12 furnishes the bias for the 6F6 pentode.

Because of this back-biasing system the two electrolytic condensers, E1 and E2, are insulated from chassis.

So much for the circuit design. We now will touch upon the question of chassis lay-out. The steel chassis measures 12 inches in length, 9 inches in width, and 4 inches in depth.

A glance at the top chassis illustra-

THE COMPONENTS LIST AND SCHEMATIC CIRCUIT DIAGRAM of The Trans-Ocean Dual-Wave "6"

Coil Box: Radiokes dual-wave coil box complete with two gang tuning condenser. Type.

C1, C3, C4, C5, C8: .1 mfd. fixed tubular condensers.

C2, C6: .0001 mfd. fixed mica condensers.

C7, C9: .02 mfd. fixed tubular condensers.

C10: .01 mfd. fixed tubular condenser.

C11: .5 mfd. fixed tubular condenser. C12: .25 mfd. fixed tubular condenser.

C13: 25 mfd. electrolytic condenser.

C14: .001 mfd. fixed mica condenser.

DS: Dynamic speaker to match type

6F6 output tube and with field resistance of 2500 ohms. (Amplion, Rola).

E1, E2: 8 mfd. 500-volt test electrolytic condensers.

IF1, IF2: 465 k.c. intermediate frequency transformers.

PT: Power transformer 385-0-385 60 m.a. secondary, two 6.3-volt windings and one 5-volt winding.

R1, R6, R7, R8: 1-megohm resistor.

R2, R11: 50,000-ohm resistor.

R3, R5: 250-ohm 10 m.a. W.W. resistor.

R4: 100,000-ohm resistor.

R9: 400-ohm 10 m.a. W.W. resistor.

R10: 200,000-ohm resistor.

R12: 275-ohm 100 m.a. W. W. resistor.

TC: 500,000-ohm potentiometer.

VC: 500,000-ohm potentiometer.

VD: 15,000-ohm voltage divider.

Valves: AK2, 6K7, 6H6, 6J7 or 6F5.

6F6, 5Z4 with sockets to suit. (Mullard, Philips, Radiotron, Raytheon).

Electric Eye: Special visual tuning valve type 6E5, with socket.

Sundries: Belden wire, 1yd, braided wire, fibre component mounting strip, six terminals, one 4-pin socket, marquis polarised socket and plug, full-vision tuning dial, four knobs, nuts and screws, two miniature grid clips and one standard grid clip, chassis measuring 12 inches by 9 inches by 4 inches.

Sundries: Belden wire, 1yd, braided wire, fibre component mounting strip, six terminals, one 4-pin socket, marquis polarised socket and plug, full-vision tuning dial, four knobs, nuts and screws, two miniature grid clips and one standard grid clip, chassis measuring 12 inches by 9 inches by 4 inches.

Sundries: Belden wire, 1yd, braided wire, fibre component mounting strip, six terminals, one 4-pin socket, marquis polarised socket and plug, full-vision tuning dial, four knobs, nuts and screws, two miniature grid clips and one standard grid clip, chassis measuring 12 inches by 9 inches by 4 inches.

Sundries: Belden wire, 1yd, braided wire, fibre component mounting strip, six terminals, one 4-pin socket, marquis polarised socket and plug, full-vision tuning dial, four knobs, nuts and screws, two miniature grid clips and one standard grid clip, chassis measuring 12 inches by 9 inches by 4 inches.

Sundries: Belden wire, 1yd, braided wire, fibre component mounting strip, six terminals, one 4-pin socket, marquis polarised socket and plug, full-vision tuning dial, four knobs, nuts and screws, two miniature grid clips and one standard grid clip, chassis measuring 12 inches by 9 inches by 4 inches.

Sundries: Belden wire, 1yd, braided wire, fibre component mounting strip, six terminals, one 4-pin socket, marquis polarised socket and plug, full-vision tuning dial, four knobs, nuts and screws, two miniature grid clips and one standard grid clip, chassis measuring 12 inches by 9 inches by 4 inches.

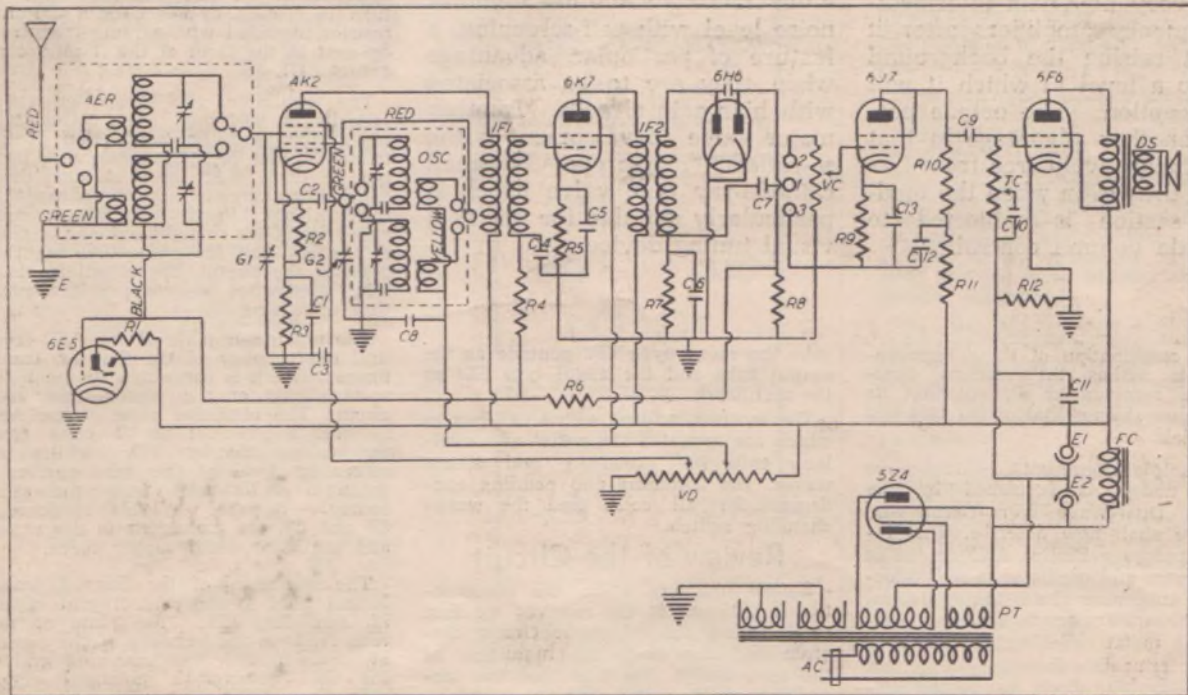

tion will show that the AK2 octode is mounted in the front left-hand corner. Directly behind it, in the order mentioned, are IF1 and the 6K7 i.f. tube. Next to the i.f. tube is IF2 and next to IF2 is the 6F6 pentode. Between the 6F6 pentode and the gang condenser, which is mounted centrally on the chassis, is the 6J7 a.f. tube, and between this tube and IF1 is the 6H6 diode. The power transformer, PT, is mounted in the rear right-hand corner of the chassis and the electrolytic condensers, E1 and E2, are mounted at the front right-hand corner. Between them and PT is the rectifier 5Z4.

The "Electric Eye"

The electric eye, 6E5, is mounted on a bracket secured to the front of the gang condenser. Along the rear of the chassis the power supply socket is mounted in line with the power transformer, the loud speaker socket is centrally mounted, and the three pick-up terminals are mounted next to it.

At the right-hand end are to be found the aerial and two earth terminals. On the front of the chassis the volume control is mounted at the left-hand end, the wave-changing switch protrudes through a slot cut in the chassis, and the tone control is mounted at the right-hand end.

In assembling the receiver first mount all valve sockets, i.f. transformers, power transformer, electrolytic condensers, tone and volume controls, the aerial and pick-up terminals, and the loud speaker and power sockets.

Underneath the chassis mount the voltage divider. The resistor strip, which carries the following components in the order mentioned—C9, R10, C.12, R11, R9, C13, R7, C6, C7 and R8—should be mounted when the wiring of the 6K7

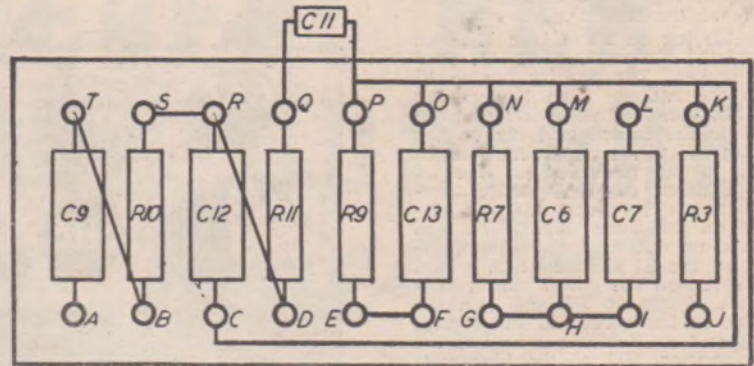

This plan diagram of the resistor strip is key-lettered to agree with the components list. Note that the connections shown between the various components should be made before the strip is mounted on the chassis.

and 6F6 tubes has been carried as far as practicable. C11 is soldered to the front of the strip. The coil-box and its associate gang condenser should be mounted last of all.

The sockets for AK2, 6K7 and 6F6 tubes are mounted so that their filament-lugs face away from the coil-box. The sockets for the 6H6 and 6J7 are mounted so that their filament-lugs face the coil-box. The filament lugs on the 5Z4 socket face towards the powers transformer.

Wiring Connections

Start the wiring of the receiver by running a bare wire from the shield lug on the 5Z4 socket to the CT and earth lugs on the power transformer.

Solder another bare wire to this one and continue it along the chassis between the 6J7 and 6H6 sockets and the space to be occupied by the coil-box.

Solder this lead to the shield lug on the 6F5 socket and to the cathode and shield lugs on the 6H6 socket. Continue this lead towards the end of the chassis, bend it at right angles and solder it to the metal coating lug on the AK2 socket.

From the bend of this earth wire run another one back to a solder lug under one of the securing bolts on the 6K7 socket. From the shield lug on the 6K7 socket run another earth wire to the cathode and shield lugs on the 6F6.

Join the lower pick-up and earth terminals on the chassis by means of another earth wire and run a lead from the main earth wire to a solder lug on the holding bolt of the 6H6 socket and bend it at right angles to come up the back of the chassis to solder to the earth wire linking the two lower terminals already wired together.

From the outside volume control lug nearest to the end of the chassis, run another earth wire back to the linking wire between the two earth terminals. From the centre of the three pick-up terminals run a metal-braided lead to the remaining outside contact on the volume control, soldering the braided to the earth wire at short intervals. Solder the end lug on VD nearest to the front of the chassis to this same earth wire.

From the centre arm of the volume control run a metal-braided lead along the earth wire to the hole between the 6H6 and 6J7 sockets. This wire terminates in a grid clip for the 6J7. The braid should be soldered to the earth wire at short intervals. One lead of the .1 mfd. condenser, C3, and a lead which goes to the 70-volt tap on VD, are soldered to the SG lug on the AK2 socket. The other lead on C3 is soldered to the metal-braided volume control lead. The oscillator grid-lug on the AK2 socket has one lug of the .0001 mfd. condenser, C2, and one lead of the 50,000-ohm resistor, R2, soldered to it. The other lead of R2, one lead of the .1 mfd. condenser, C1, and one lead of the 250-ohm resistor, R3, are soldered to the cathode lug on the AK2 socket. The remaining leads on R3 and C1 join to the earth wire.

Join the two insulated lugs (negatives) of the electrolytic condensers, E1 and E2, and run a lead from them to the high-voltage centre tap on PT. One outside high-voltage lug goes to one plate lug on the 5Z4 socket, the other plate lug on this socket joining to the remaining outside high voltage lug on PT. One five-volt filament lug on PT joins to one filament lug on the 5Z4. The cathode (and other heater) lug on the 5Z4 socket joins to the second five-

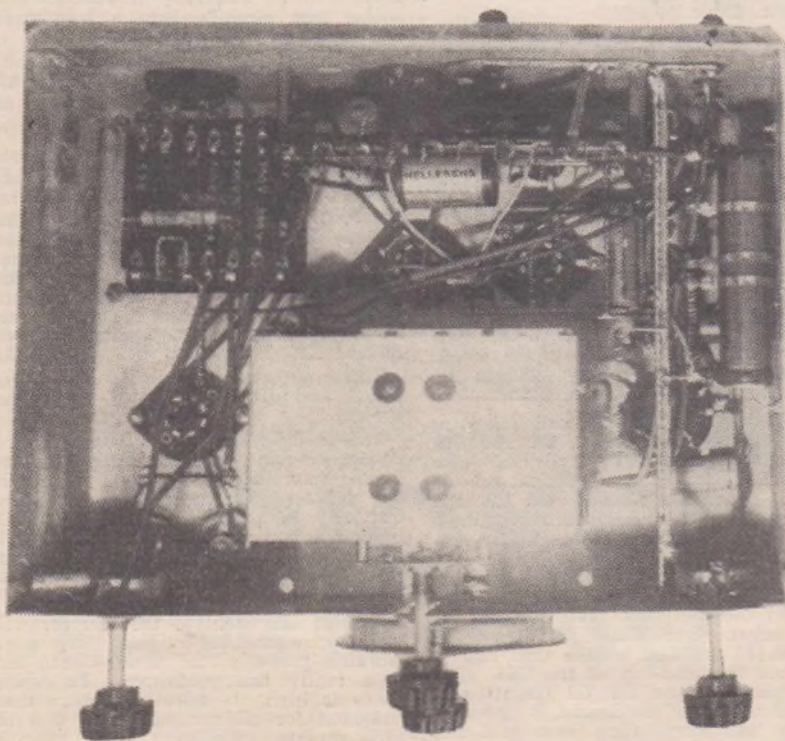

Study this under-chassis view when wiring the receiver.

volt filament lug on PT (nearest to the rear side of the chassis).

From this lug on PT a lead is taken to one of the filament lugs on the loud speaker socket. The positive lug on E1 joins to the cathode (and heater) lug on the 5Z4 socket. The positive lug on E2 joins to the screen grid lug on the 6F6 socket and to the remaining filament lug and to the plate lug on the 1.s. socket. Connect the tone control condenser between the centre and one outside lug on the Tone Control TC and join the same outside lug to the negative lug on the E1 and E2. Run a lead from one lug on the power supply socket to the C lug on PT and join the other lug on the socket to the correct line voltage tap. Solder one lead of the 250-ohm resistor, R12, to the high-voltage centre-tap lug on PT and the other lead of R12 to earth.

Run a lead from one lug of the 6-3-volt 2-ampere filament winding to one filament lug on the 6J7 and 6H6 sockets. The remaining filament lugs on each of these sockets are joined together and taken to the remaining 6.3-volt 2-ampere filament lug on PT. From the same 6.3-volt filament lug a lead is taken to one filament lug on the 6F6, the 6K7 and the AK2 sockets. From the other 6.3-volt lead on PT a wire is run to the remaining filament lug on the 6F6 and 6K7 sockets and through a 3½-ohm resistor to the remaining filament lug on the AK2 socket.

Note that the schematic circuit diagram two filament windings have been shown. The original receiver had only one filament winding, and thus a voltage dropper was required to obtain the 4-volt filament supply for the AK2. A separate 4-volt winding for this tube would overcome the necessity for such a resistance.

Join the plate lug of the 6F6 socket to the remaining lug on the 1.s. socket. Join together the cathode and suppressor lugs on the 6K7 socket and solder to them one lead of the 250-ohm resistor, R5, and one lead of the .1 mfd. condenser, C5. The remaining lead on each of these components joins to the earth wire.

The green lead from IF2 joins to the plate lug on the 6K7 socket whilst the red lead goes to the screen grid lug on the 6F6 socket. The white lead from IF2 joins to the detection diode of the 6H6 socket, to which also is soldered one lead of the .001 mfd. condenser C14. From the earth wire run a lead to the remaining cathode lug on the 6H6 socket. Attach a metal braided wire to the red pick-up terminal.

Resistor Strip Wiring

Now study the diagram showing the mounting of the components on the resistor strip. Note that this is key-lettered. Mount the strip so that the "A" end is nearest to the power transformer and floor of the chassis. Run a lead from the vacant lug on the tone control, TC, to the A lug on the strip and to the control grid lug on the 6F6 socket. From lug B run a lead to the plate and screen grid lugs of the 6J7 socket. Lug E joins to the cathode and suppressor lugs of the 6J7. The black lead from IF2 goes to the G lug on the strip. Lug J is wired to the a.v.c. diode plate lug on the 6H6 socket and to the vacant lead on the .001 mfd condenser C14.

Lug Q on the strip joints to the two loud speaker lugs which already have been joined together, and to the positive end of the voltage divider VD. The

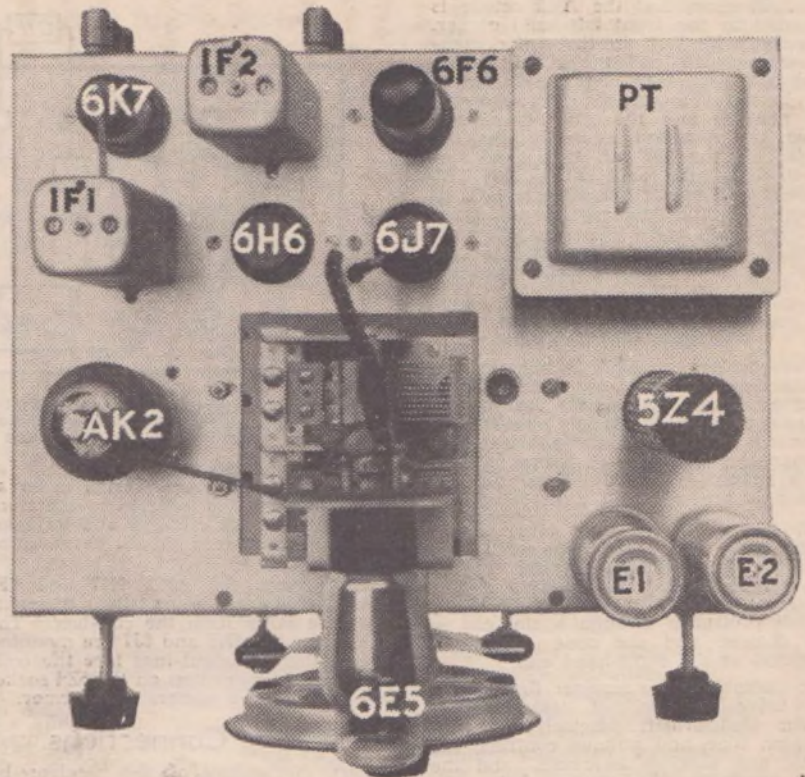

Key-lettered to agree with the parts list and the wiring description, this illustration shows the top chassis lay-out of the assembled receiver.

other end of the braided lead attached to the red pick-up terminal is wired to lug I on the strip, the braid being earthed to the earth wire. Join one lead of the 1-megohm resistor, R6, to the a.v.c. diode.

The other lead of R6 joins to one lead of R4. The Black lead of IF1 joins to the remaining lead on R4 and to one lead of the .1 mfd. condenser, C4. The other lead of C4 joins to the earth wire. The Green lead from IF1 is soldered to the plate lug on the AK2 socket. The Red lead from IF1 goes to the maximum "B" plus lug on the voltage divider VD. Next mount the coil-box, securing it to the chassis by means of the four mounting bolts. A lug is bolted down under one of the rear securing bolts on the side of the box and to this is soldered one lead of the .1 mfd. condenser, C8. The other lead of C8 joins to the Yellow lead from the coil-box, to the screen grid lug on the 6K7 socket, and to the 90-volt lug on the voltage divider, VD.

The Black lead from the coil box joins to the junction point of R4 and R6. The Red lead from the coil box joins to the Red (top) aerial terminal on the chassis. The Green lead from the coil box joins to the middle aerial terminal. The Green lead from the oscillator section of the coil box is wired to the vacant lug of C2. The Red lead from the oscillator section of the coil box joins to the oscillator plate lug on the AK2 socket. The White lead from the side of IF1 is fitted with a grid clip to slip over the grid-cap of the 6K7. The fixed plate lug on the G1 (front) section of the gang condenser is provided with a lead terminating in a grid clip for the control grid of the AK2.

The next job is the mounting and wir-

ing of the socket for the "electric eye." Mount the six-pin socket on the mounting bracket so that its filament terminals face towards the right. A five-wire cable will be necessary to connect this socket into circuit. Run a lead from one filament lug on the 6E5 socket to one filament lug on the 6J7 socket and join the other filament lug on the 6J7 socket to the remaining filament lug on the 6E5 socket.

Connect one lead of a 1-megohm resistor, R1, to the plate lug on the 6E5 socket and join the other lead of this resistor to the target lug on the same socket. From this lug a lead should be taken off to the Q lug on the resistor strip. The cathode lug on the 6E5 socket is wired to the M lug on the resistor strip. The grid lug on the 6E5 socket should be wired to the junction between R4 and R6.

This completes the wiring of the receiver and all is ready for the initial try-out.

Theoretically, as the coils and tuning condensers have been carefully adjusted during manufacture, there is no necessity for any adjustments to the tuned circuits. In practice, however, it will be found that varying lead lengths will necessitate the use of regular alignment methods to make the receiver give of its best.

Careful alignment of the receiver will well repay the set-builder for, when working properly, the Trans-Ocean Six is a really fine performer. Its sensitivity is high, its selectivity more than sufficient for all normal needs, and its tone quality excellent. The "electric eye," although a desirable refinement, may be dispensed with if desired.

WONDERFUL NEW DUAL-WAVE SUPERHET

Transocean

Build this Radiokes Kit-Set in your Spare Time!

See full description of this amazing set in this issue.

Save money—have a few hours of fascinating fun in assembling — and then enjoy superb radio reception for years to come with the great new Radiokes “TRANSOCEAN” Kit-set.

Read on the opposite pages full details of its performances. Glance through the assembly instructions. Decide NOW that you will get yourself this wonder-set.

When you assemble the Radiokes “TRANSOCEAN” Kit-set you get at an amazingly moderate cost, the six metal valve dual-wave Superheterodyne that you have always hoped for! Just think — the Radiokes Kit-set, complete to the smallest detail, costs only £11/17/6. Valves and speaker are the only extras you need. No technical knowledge is required to assemble the Radiokes Kit-sets—simplified assembly instructions as on the opposite page, make construction amazingly simple.

You cannot fail to get maximum efficiency. Radiokes engineers have already made sure that you can go right ahead wiring up the chassis and getting the best results.

Order the “TRANSOCEAN” NOW—it’s the best radio “buy” you have ever seen!



Advanced 1936 FEATURES

The “Transocean” incorporates these wonderful features—Iron-Cored I.F. Transformers, Metal Valves, with Octode conversion, Pi-wound Litz high selectivity coils, dual-wave tuning unit, “Magic-eye,” “Colourvision” dial, tone control, etc., etc.

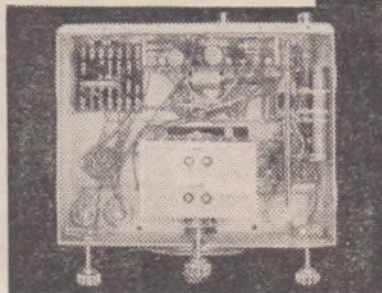
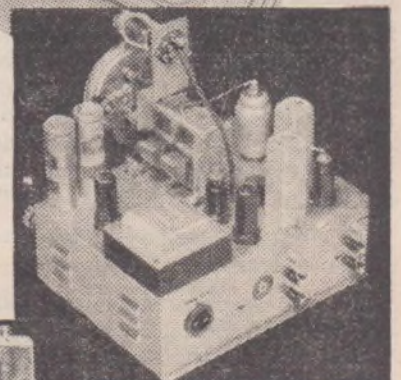

FREE

Send the coupon NOW for splendid FREE folder which gives full details of the “Transocean,” simplified constructional details, and many photographs. Write NOW.

RADIOKES TRANSOCEAN KIT-SET

Send this for FREE FOLDER

Radiokes Ltd., Box 10 P.O., Redfern. Please send me right away, post free, free folder giving complete details, photos, etc., of the “Transocean” Kit-set.

Name

Address

Mod. Radio

Obtainable in Victoria from: A. J. Veall Pty. Ltd., 243-249 Swanston St., Melbourne; Homecrafts Pty. Ltd., 211 Swanston St., Melbourne; Hartley's Pty. Ltd., 270 Flinders Street, Melbourne; Healings Pty. Ltd., 261 Swanston Street, Melbourne; Factory Representative: R. E. Trickey & Co., 403 Bourke St., Melbourne. Wholesale distributors in every capital city of Australia and New Zealand.

This photograph shows how the S.W. Receiver will appear when completed.

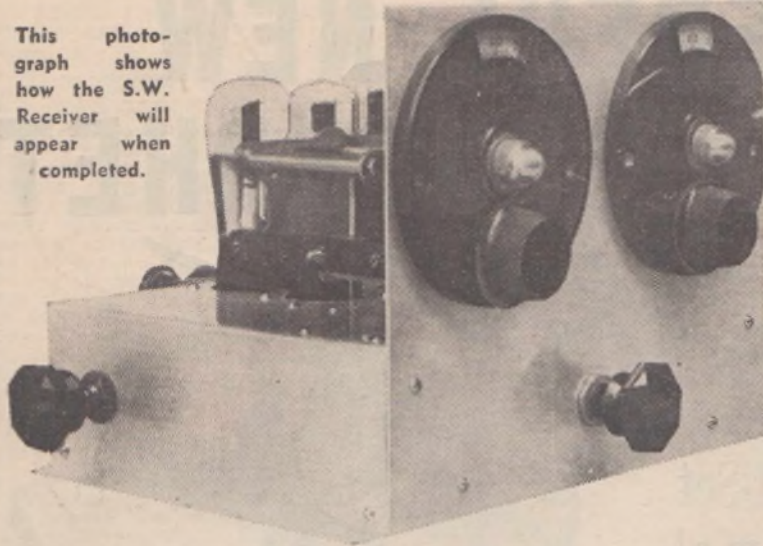

The All-Band S/W Three

A compact A.C. operated short - wave receiver which is capable of tuning from 5 to 200 metres.

By H. R. SETFORD

MANY beginners are deterred from attempting to build a short wave receiver because of the intricate adjustments usually associated with this type of receiver.

That this need not be so is ably demonstrated in the set which we shall now describe.

The majority of the coils for this receiver have only one winding and this eliminating the usually critical adjustment of the reaction winding to give smooth oscillation on all bands.

The tuning range of the receiver is from 5 to 200 metres.

As full band spread is possible on any commercial or amateur band within these limits this makes this receiver particularly suitable for both experimental stations and short wave broadcast listeners.

The amateur is well catered for as the receiver may be used with exceptional stability as a super regenerative on the 5 and 10 metre bands.

The receiver is also readily adaptable for battery operation and for this reason should appeal greatly to experimenters who have not the advantage of an A.C. supply to provide power for their receivers.

Although the set is designed only to give comfortable head-

phone strength, the output may be amplified through the audio stages of existing broadcast sets to give loud speaker results.

In operation the receiver is exceptionally quiet and free from hum, whilst its simplicity of control should appeal to both the experimenter and the beginner.

THREE type 56 valves are used in this receiver. The first 56 operates as a grid leak detector with a modified form of electron coupling to provide regeneration.

A feature of this system is its very smooth control of oscillation.

The regeneration control is a 50,000 ohm wire-wound potentiometer connected in the plate supply lead to the detector valve.

The band spread system is more or less standard, and consists of a 25 mmfd. con-

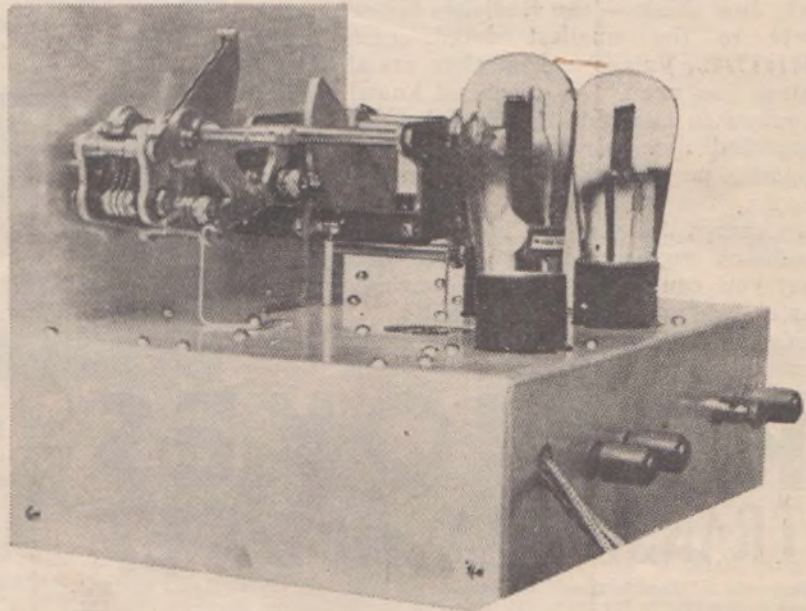

A rear view of the receiver. The terminals mounted on the side of the chassis are (from left to right) the headphone terminals, the earth and the aerial terminals.

denser in parallel with which is a 100 mmfd. condenser.

The first is the main tuning control and the latter is used to select the particular band in which operation is desired.

On the five lower frequency bands the aerial is connected to the grid end of the tuning coil through the 10 mmfd. aerial coupling condenser.

On the two higher frequency bands (5 and 10 metres) the aerial coupling is still further reduced by winding a very small coil alongside the grid end of the tuning coil. (See Fig. 1).

To avoid the possibility of introducing fringe howl resistance, coupling is used to transfer the signal energy to the first stage amplifier valve.

A modified form of direct coupling is employed between the first and second stage amplifier valves.

The values in this portion of the circuit have been selected to give efficient operation over wide ranges of applied voltages and result in high gain at quite low plate voltages.

The original receiver was designed to operate from an existing power pack, and it was found necessary to include a resistance filter to enable the last vestige of hum to be removed from the receiver's output.

Review of Components

The need for quality components in a receiver of this type cannot be too

strongly stressed. Reference to the photographs will show that specially constructed tuning condensers were used in the original model.

These special condensers are not necessary for the efficient operation of the receiver. Midget condensers are quite suitable for use as tuning condensers, providing they are of the correct capacity.

Whatever the type of tuning condenser employed, the rotor plates must be free from play of any kind.

When purchasing these components, an excellent test is to hold the frame of the condenser in one hand and with the other hand exert pressure on the shaft in every direction; should any play in the shaft manifest itself the condenser

should be rejected.

Valve sockets are another thing which require careful selection. Sockets must

COIL CONNECTIONS

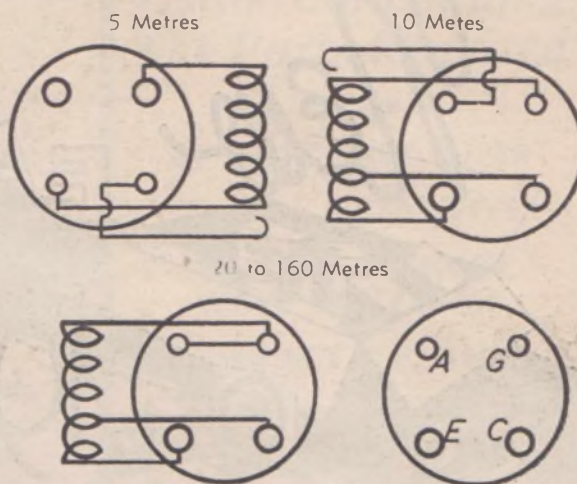

Fig. 2: Diagram illustrating the coil connections to both formers and sockets. All connections are viewed from below the chassis.

THE LIST OF COMPONENTS AND CIRCUIT DIAGRAM

- C1—10 mmfd. Midget condenser.
- C2—150 mmfd. Midget condenser.
- C3—25 mmfd. Midget condenser.
- C4—.00025 mfd. mica condenser. (T.C.C.)
- C5, C6—.001 mfd. mica condenser (T.C.C.)
- C7, C8—.006 mfd. mica condensers. (T.C.C.)
- C9, C11, C12.—4 mfd. 250 volt condensers. (T.C.C.)
- C10—.1 mfd. tubular condenser. (T.C.C.)

- R1, R5.—1 megohm resistors. (I.R.C.)
- R2—10,000 ohm resistor. (I.R.C.)
- R3—.5 megohm resistor. (I.R.C.)
- R4—50,000 ohm resistor. (I.R.C.)
- R6, R7, R8—5000 ohm resistors. (I.R.C.)
- RC—50,000 ohm wire wound potentiometer.
- Sockets—3-5 pin, 1-4 pin.
- Chassis—Aluminium, 9 inches by 7 inches by 2½ inches. Front panel—9 inches by 7 inches.

- R.F.C.—50 turns of 28 gauge S.S.C. wire on 3/8 diameter former.
- Aerial and earth terminals, phone terminals, nuts and bolts, book up wire, ¼lb. of 22 g. tinned copper wire, ¼lb. of 22 D.C.C. wire, two ounces of 28 gauge S.S.C. wire, 7 4-pin 1¼-diameter formers.

- Valves—3 type 56 or, for battery operation, 3 type 76. (Mullard, Philips Radiotron Raytheon).

THE CIRCUIT

As the schematic circuit diagram shows, the receiver employs a regenerative detector and two audio amplifying stages. The first of these is resistance coupled whilst the second is directly coupled to the first. Indirectly heated valves are used in all stages of the receiver.

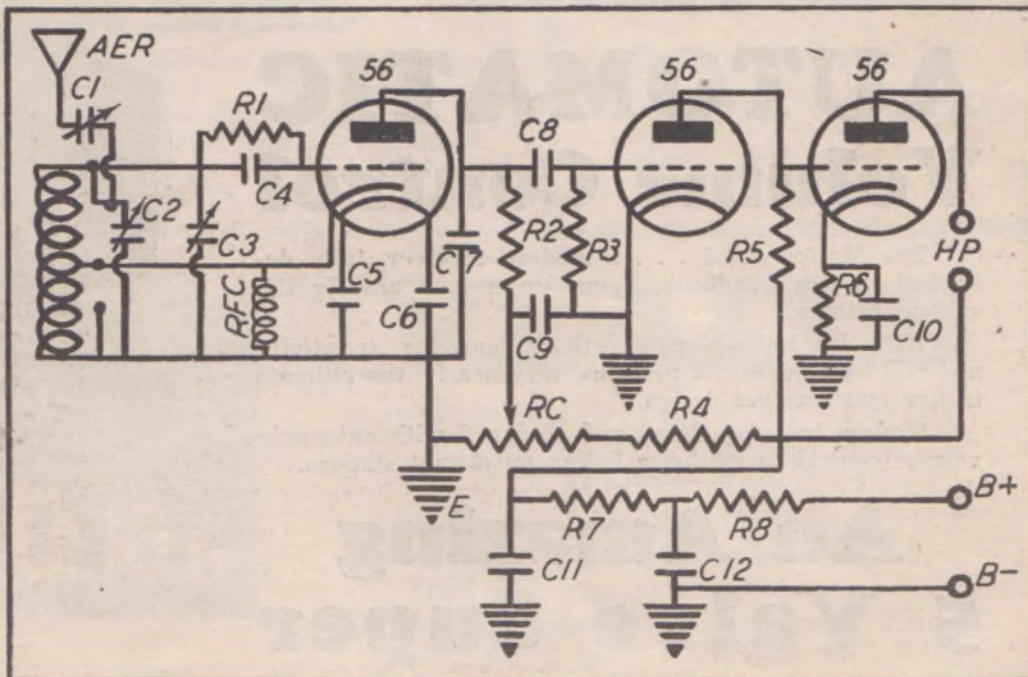



The MASTER A.C.

Ultra Modern Valves

AUTOMATIC Volume Control

The Master A.C.5 . . . a modern receiver, fully described in this handbook, opens up a new era for the critical listener.

With its knife-edge selectivity, amazing sensitivity and real tone quality, it presents, very nearly, the ultimate in low cost receiver design.

Modern in every detail and equipped with automatic volume control to minimise fading on distant stations.

An Amazing 5 Valve Super

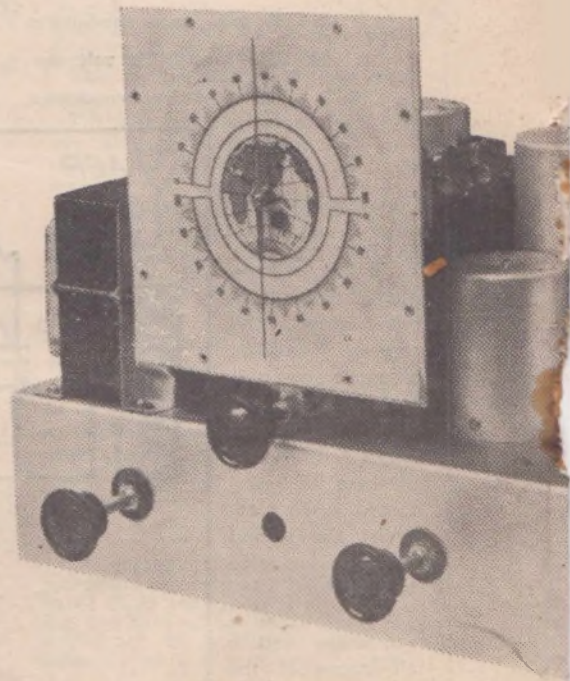

WRITE FOR A COPY OF V
BIG 80-PAGE RADIO
ELECTRICAL CATALOGUE

Buy the Complete Kit of CAREFULLY MATCHED PARTS

The Master A.C.5 as described in this Handbook is procurable from Vealls in Kit-Set form. This means that you can buy the complete parts ALL CAREFULLY MATCHED AND EXACTLY AS SPECIFIED BY A. K. BOX, TECHNICAL EDITOR OF THE LISTENER IN. The complete Kit-Set includes the stamped and drilled chassis together with full constructional details. ENSURE SUCCESS BY USING THESE MATCHED COMPONENTS.

SUPER FIVE

Featuring
**EASY STEP
WIRING**

No need for technical knowledge when you build a Master 5 . . . "Easy Step" wiring diagrams make failure impossible.

The Velco Master A.C.5 Kit Set is priced at only £6/10/6, and includes everything necessary to build the complete chassis. Valves 82/, and Speaker extra as selected.



**ALL ELECTRIC
MODEL**
£6/10/6

VEALLS
AND
— FREE

Vealls Can Supply The Parts Required

for the

4½ WATT BABY SUPER

The ALL METAL FIVE

**The CRUISER SHORT
WAVE CONVERTER**

COMPACT A.F. AMP.

All Band S.W.3

**The HIGH FIDELITY
AMPLIFIER**

**The Pre-Selected
UNIVERSAL SUPER**

SUPREME T.R.F.3

TRANS OCEAN SIX

MIGHTY ATOM 2/3

UNIVERSAL D.W.

SUPER 7

A.C. MASTER 5

Iron-Cored Melodious 3

Beginners Battery Super

Hartwright Crystal Set

WRITE FOR QUOTATIONS

*KEENEST PRICES IN
MELBOURNE*

VEALLS

**EVERYTHING RADIO
AND ELECTRICAL**

243-249 Swanston St., Melbourne, C.1.

168 Swanston St., Melbourne, C.1.

299-301 Chapel St., Prahran, S.1.

3-5 Riversdale Rd., Camberwell, E.6.

Central 3058 (7 lines), 10524, Wind. 1605, W1188

be obtained which give a firm, smooth contact to the valve pins.

All fixed condensers with the exception of the two filter condensers, the detector B plus by-pass, and the cathode by-pass, should be high quality mica dialectic types.

The three 4mfd. condensers can be of the block type, tested to 250 volts working. These condensers may be replaced with electrolytics if desired.

The two 500 ohm resistors comprising the filter and the 50,000 ohm regeneration control, should be of the wire wound variety.

The remaining resistors in the circuit should be of the carbon or metallised type.

Little need be said of the coil formers, as several reliable makes of these components are obtainable.

The chassis is constructed of aluminium. Copper would, undoubtedly, be an improvement, but aluminium chassis are so readily obtainable that the majority of constructors favor this material.

If aluminium is used this may be given a clean mat surface by immersing it in a solution of common washing soda for approximately twelve hours.

The solution is prepared by dissolving four pounds of soda in a sufficient quantity of water just to cover the chassis.

Vernier dials for use in short-wave receivers should also be very carefully selected.

Inferior dials having backlash must be avoided if satisfactory results are to be obtained.

Dials of reputable make which have a smooth vernier movement free from backlash should be quite satisfactory.

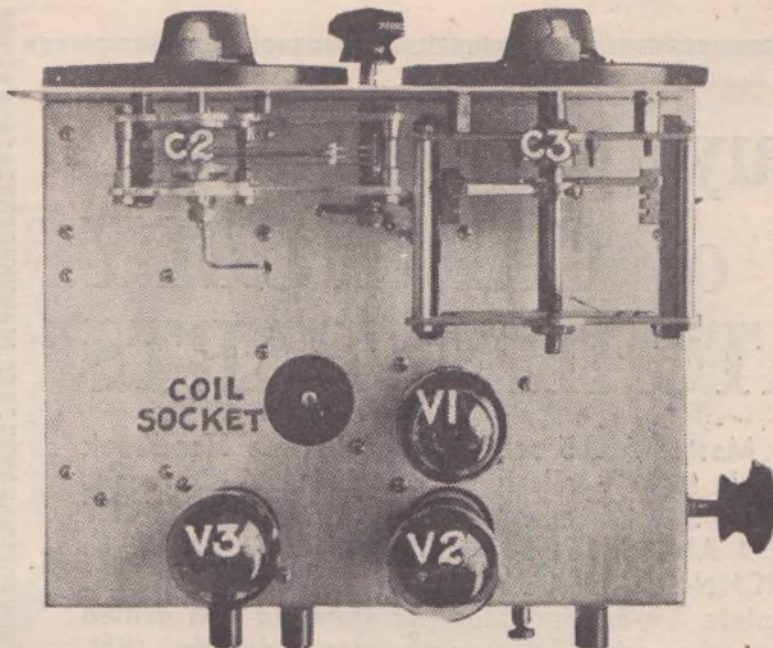

This plan view of the set depicts the arrangement of parts on top of the chassis.

The Coils

The coils for the receiver are wound on plug-in formers having an outside diameter of $1\frac{1}{4}$ inches.

The five metre coil consists of two turns of 22 gauge tinned copper wire spaced wound to cover three-quarters of an inch. The aerial coupling turn is wound alongside the top turn of this coil, and provides reduced aerial coupling on this band.

The ten metre coil has seven turns of

22 gauge tinned wire spaced over three-quarters of an inch, with a cathode tap taken at $1\frac{1}{2}$ turns from the bottom of this coil.

A one-turn coupling coil is wound alongside the top turn of this coil with 22 D.C.C. wire.

The 20-metre coil is also wound with 22 gauge tinned wire and has six turns spaced over three-quarters of an inch, with the cathode tap taken at half turn from the bottom.

The 40, 60 and 80 metre coils are wound with the gauge 22 D.C.C. wire.

The 40-metre coil has ten turns spaced over three-quarters of an inch, with the cathode tap taken at half turn from the bottom.

The 60-metre coil has $17\frac{1}{2}$ turns of the same gauge wire close wound. The cathode tap for this coil is taken $1\frac{1}{4}$ turns from the bottom.

Thirty-four turns of 22 D.C. wire comprise the 80-metre coil, and the cathode tap is at $1\frac{1}{4}$ turns from the bottom.

The 160-metre coil consists of 65 turns of 28 gauge S.S.C. wire close wound, with the cathode tap taken at $1\frac{1}{2}$ turns from the bottom.

The base connections for all coils are shown at Fig. 2.

Construction

The photographs show clearly the placement of the parts, but for the benefit of those readers who are just entering the field of set construction a brief outline of the points to watch in the assembly of the parts will be given.

The two tuning condensers, C2 and C3, are mounted on the aluminium panel, which is solidly bolted to the main chassis.

C3 is on the left of the panel with the band setting condenser, C2, mounted on the right.

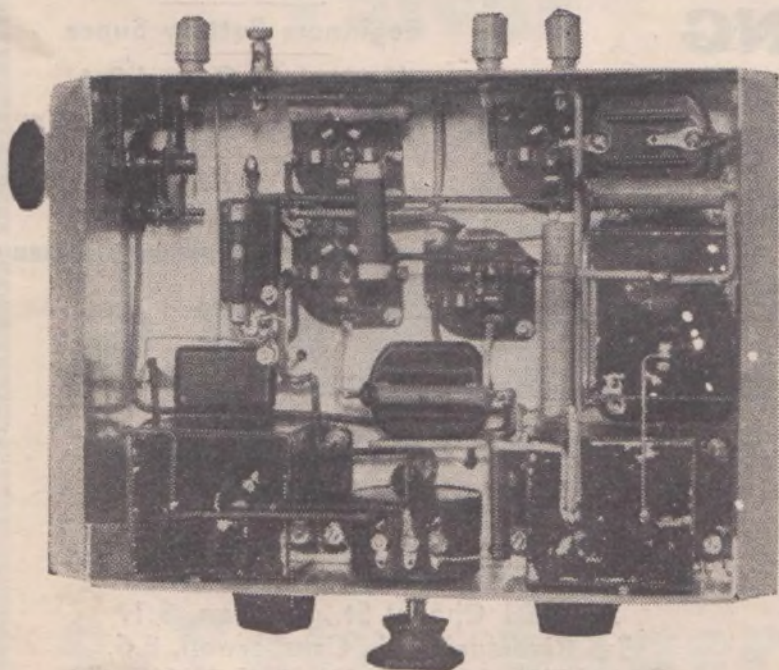

An underneath photograph of the completed receiver. This illustration shows the placement and wiring of the various components beneath the chassis.

The aerial coupling condenser, C1, mounted on the rear left side of the chassis, and this component, as well as the aerial terminal and the two phone terminals, must be carefully insulated from the chassis.

The placement of the other components can be plainly seen from the photographs.

Wiring Details

When all the parts have been mounted the wiring may be commenced by wiring the filament circuits of the three valve sockets.

The whole of this filament wiring should be carried out in metal braided wire, the outside braid of which is connected to earth.

This system of filament wiring precludes the possibility of A.C. hum being introduced into the output of the receiver by the A.C. field surrounding the filament wiring of the set.

Connect together one side of each of the three valve sockets with shielded wire and connect a similar piece of wire about three feet long to one of these terminals. The remaining filament terminals of these sockets are connected together in the same way, and another piece of the shielded wire connected to them. The outside braid of this wiring should be bonded together and connected to earth.

Connect the aerial terminal and the moving plates of C1 together.

The fixed plates of this condenser connect to the corresponding plates of C2 and to terminal A on the coil socket. The G contact of this socket connects to the fixed plates of C3 and to one contact each of C4 and R1. The remaining terminals of these components connect together and join to the G contact of V1.

The E contact of the coil socket connects to earth, whilst the C contact of this socket connects to the cathode of V1. R.F.C. is connected between the cathode of V1 and earth. The plate of V1 joins to one contact each of C7 and C8 and to one side of R2. The remaining contact of this resistor connects to the arm of RC and to one contact of the by-pass condenser, C9. The unconnected contacts of C7 and C9 join to earth.

The grid terminal of V2 connects to the remaining contact of C8 and to one side of R3. The other side of R3 joins to earth. The plate of V2 connects to the grid of V3, and to one side of the resistor, R5. The remaining terminal of this resistor joins to one side each of R4 and R7 to one of the phone terminals and to one contact of

the condenser C11. The unconnected side of C11, one contact of C12, and one of the outside terminals of RC, connect to earth. The remaining contacts on R4 and RC join together. The cathode of V3 connects to one terminal each of R6 and C10. The remaining contacts of which join to earth. The plate of V3 is wired to the remaining phone terminal. One side of R3 connects to the unconnected contacts of R7 and C12.

The "B" positive lead connects to the remaining contact of R8. The filament by-pass condensers C5 and C6 should now be connected. One terminal of each of these components connect to the filament terminals of the valve socket, while their remaining contacts join to earth.

Power Supply

As yet no mention has been made of the power supply for this receiver. The original model was designed to operate from an existing power supply which delivered approximately 200 volts on load. Included in this supply was a 2.5 volt filament winding, which was used to light the three valves.

Those about to build this receiver may, if they so desire, obtain the "B" supply voltage from their existing receivers. In that case a separate filament transformer should be obtained to supply the filament voltage. A centre tap resistor should be connected across the filament supply to the valves and the centre tap connected to the earth terminal of the receiver.

By substituting 76 type valves for the 56 type specified in the parts list, this receiver may be operated from a six-volt accumulator and dry "B" batteries. In this case the filament centre tap must be omitted and the negative terminal of the accumulator connected to earth. The total "B" battery consumption of the set is under 10 milliamperes, so that long life may be expected from the dry batteries.

Operation

When the wiring is completed and has been thoroughly checked and found correct, the valves may be inserted and the aerial and earth leads connected to their terminals.

Plug in the 80 metre coil and switch on the receiver. On rotating the regeneration control the receiver should oscillate smoothly, and it should be possible to receive either code signals or the harmonics of local broadcasting stations.

The average broadcast listener will, at present, find little to interest him on the 5 and 10 metre bands,

and these coils may be omitted if so desired. However, a word of explanation may be given to those who are desirous of listening on these bands. On both of these bands the condenser, C2, should be set at minimum capacity, and all tuning carried out on C3. The detector valve may be made to either regenerate or super-regenerate on these bands by careful manipulation of the regeneration control.

Super-regeneration is denoted by a loud hiss something similar to the noise level of a powerful super-heterodyne operating full out. In most cases a fairly powerful signal will reduce this noise level to normal proportions. Little more need be said of the operation of this receiver, for the tuning of the set is simplicity itself.

Should any trouble be experienced in making the detector valve oscillate on the higher frequencies the cathode tap on the coils should be moved slightly closer to the grid end of the coil until the detector valve may be made to oscillate freely over the whole band.

If it is desired to amplify the output of this receiver through the amplifier stages of the normal broadcast receiver a 10,000 ohm resistor should be connected across the phone terminals and a .1 condenser connected from the plate of the last 56 to the live pickup terminal on the broadcast set. The only other connection necessary is that between the chassis of the two receivers.

Tests carried out with this receiver on all the amateur and commercial broadcasting bands proved it to be exceptionally sensitive.

American amateur code signals can be received at excellent strength using about six feet of wire connected to the aerial terminal.

Amateur phone signals from all parts of Australia are received at maximum phone strength.

All of the short wave broadcasts from London, Paris, Germany, America, Russia and Holland can be received at excellent strength, even under adverse weather conditions.

This receiver can be confidently recommended to those in search of an easily constructed and highly sensitive short wave receiver for either A.C. or battery operation.

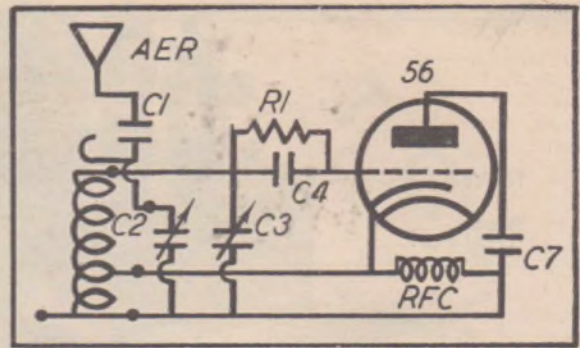

A circuit diagram showing how the 5-metre coil reduces the aerial coupling capacity.

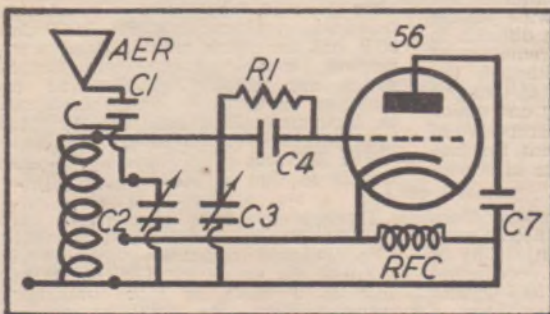

This circuit diagram shows the wiring of the detector when using the 10-metre coils.

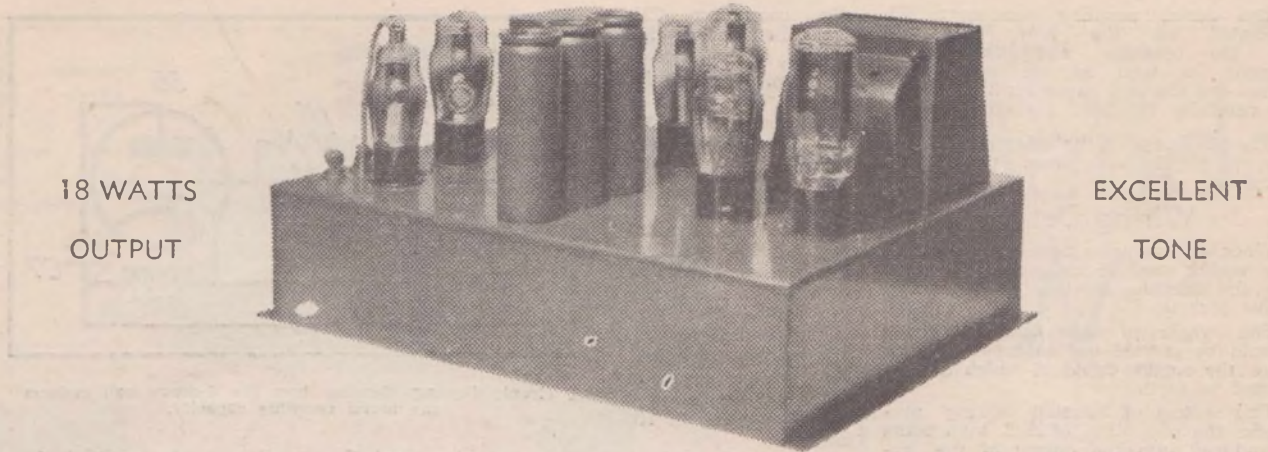

The Listener In High Fidelity Amplifier

By A. K. BOX

Faithful Reproduction from 40 to 13,000 cycles is this Amplifier's main feature.

IS High Fidelity merely a catch phrase? This is the question being asked by the discerning, but not necessarily technically minded, member of the public. He has seen so many high sounding tags applied to radio receivers and reproducers that he can be pardoned for being somewhat sceptical of this latest creation of the engineer-cum-salesman.

Unlike many of radio's catch-phrases, however, High Fidelity

means something really worth while. It means more musical radio music and less of the distortion and tone limitation which exists with the majority of present-day receivers.

High Fidelity is the faithful reproduction of every cadence of the original tone. It aims neither at painting the broadcasting lily nor at compromising with the present tonal sootiness of that lily.

RADIO apparatus capable of high fidelity reproduction is attracting more than passing interest amongst both broadcasting station engineers and radio set designers. Every day sees some further step forward in a technique which has for its object the faithful electrical recreation of speech and music.

New types of transmitting stations, better studio equipment and acoustics, and, when recorded programmes are used, better methods of recording, all are adding to the fidelity of broadcast transmissions. A lot has been talked about high fidelity. Let us see just what the term means.

The human ear is able to respond to tones ranging from some 20 cycles per second to 16,000 cycles per second. These

extremes vary with the individual and with his age and sex. Children are credited with extremely wide range hearing, whilst the old find it difficult to hear musical tones above a frequency of 8000 cycles per second. Although the ear is a wide range recorder of tones, it also is a very accommodating one which possesses the physiological property of compensating to a large extent for frequency gaps in the tone range of speech or music.

The absence of one or more of these frequencies, may not be noticed even by the trained musician but, if as is the case in the majority of reproducing systems, everything above 5000 cycles per second is eliminated, we have a state of affairs which can be tolerated only by the most un-musical listener. Wide range, or high fidelity, reproduc-

tion is not easy to obtain. In the past the design of broadcasting stations which could transmit such frequencies has been impossible. Recordings of the great artists failed to convey the true perspective of the originals because they eliminated the overtone frequencies above four or, perhaps, 5000 cycles.

This state of affairs existed with even the electrically recorded types of gramophone records, the earlier mechanical recordings being much worse. Today, however, it is possible to build broadcasting stations which are flat, i.e., even in their reproduction, from the lowest to the highest audible frequencies.

Unfortunately we have none of these very High Fidelity stations in Australia yet, but some of the newer National stations, such as 6WF, 5CK, 2CO, 2NC, 3LO and 7NT, have a flat frequency response from 30 cycles per second upwards to 8000 cycles. Many of the "B" class stations also have very faithful transmission characteristics. In Sydney 2GB has for some months been transmitting special gramophone records which are capable of handling frequencies up to 10,000 cycles per second. In Melbourne, 3DB has special recordings which go up to over 7000 cycles, whilst 3KZ has High Fidelity equipment similar to that at 2GB.

There is one cardinal point in audio amplifier design. To obtain tone quality a large power output is essential. This involves the employment of valves capable of 3 watts or more undistorted output. Next, the amplifier must be very carefully designed to ensure that it amplifies equally all frequencies within its range.

Quality Products

by

I.R.C.

T.C.C.



METALLISED RESISTORS NOISELESS — CONSTANT

All I.R.C. Resistors are:—

- 1.—Impervious to moisture.
- 2.—The Noise Level is guaranteed **Lower than any other Resistor**
- 3.—Ability to withstand Overload
- 4.—Resistance Rating Accurate.
- 5.—Defies Humidity.

1 Watt, 1/3. 2 Watt, 2/

I.R.C.

T C C

Type "M"

Mica Guaranteed
Within 10 per cent.
of rated Capacity and
Not Less than 5000 ohms at
1000 Volts D.C.

MADE IN AUSTRALIA

.00005 to .00025	1/1	.004 to .006	1/7
.0003 to .005	1/1	.007 to .009	1/9
.0006 to .0009	1/3	.01	2/1
.001 to .003	1/6	.02	3/6



8mfd. type F.W. Electrolytic
List Price 3/6

500 V. Working Peak
525 V. Peak Surge
Diameter—1in.
Length—2½ in.

TYPE 33 TUBULAR CONDENSERS

All "TCC" Condensers are guaranteed of dependable service and accuracy, each condenser being subject to strict and rigid tests. They are within 15 per cent. of their rated value, and therefore, offer superior quality at competitive prices.

TUBULAR
CONDENSERS



Capacity	Working Voltage	Price
.0001 m.f.d. to 1 m.f.d.	400	1/
.2 m.f.d.	400	1/2
.25 m.f.d.	400	1/4
.5 m.f.d.	400	1/6

BRUNO Velocity Microphone

SPECIFICATIONS
SK2

Freq. Response is not equal to 2db from 60 to 10,000 cycles.
Output Imp., 200 ohms or 500 ohms.

SK4

Freq. Response is not equal to 1db from 50 to 12,000 cycles.

Output, — 64 db.

List Prices

SK2	£10/10/-
SK4	£15/15/-

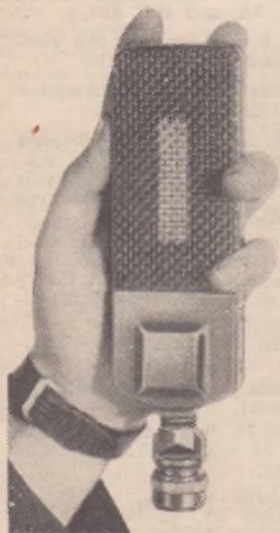

Stedipower Moulded PAPER CONDENSERS

An Entirely New Line in Paper Condensers, featuring a paper condenser in a Moulded Bakelite Case that is entirely water-tight. This condenser was immersed in water for hours and it did not affect its working.

PRICES

The Price is the same as an ordinary paper condenser. From .1 m.f. to .002 m.f.

Aust. Engineering Equip. Co., 415 Bourke St., Melbourne

Output Comparisons

The question of power output is a simple one with modern valves, and it is possible to obtain undistorted output powers ranging from 2 watts up to 18 watts without expensive apparatus and without the use of excessively high voltages. From the frequency response viewpoint the design of the amplifier is not difficult. It does not necessarily follow, either, that only triode output valves will give first-class tone quality. Properly handled, the pentode will give both an economical power output and an extended frequency response.

Having generalised on the subjects of frequency response and amplifier design, let us consider a special amplifier built up in the laboratory of The Listener In to determine exactly how good a given amplifier could be made without recourse to laboratory tricks.

As will be seen from the circuit diagram comparatively few components have been employed. The circuit is perfectly straight-forward and the amplifier uses easily obtainable valves and other components. This amplifier has a rated output of 18.4 watts at a harmonic distortion of only 5 per cent., a figure which is too low to need consideration.

This output is obtained with plate voltages of only 350 on the final stage tube. We can see the average set builder exclaiming, "What do I want with an 18 watt amplifier? I couldn't find use for it."

Notwithstanding the fact that this amplifier is large enough for public ad-

dress work, and could be used in a 1500 seat talkie theatre, its output is not sufficiently great, judged from aural standards, to warrant such a remark. This can be shown by a comparison with the standard 3 watt pentode amplifier of the 42 or 2A5 Class. From a power viewpoint the 3 watt output of the 2A5 is only 1 1/4 db. less than the 4 1/2 watt output of a pair of 45's in push pull. Similarly, the 12 watt output of a pair of 2A3's is only 6 db. greater than the single pentode, and the output of the present amplifier is less than 8 db. greater than the single pentode's output. The ear is logarithmic in its response to increase in volume, and it has been established that a 2 Decibel (db.) change is the minimum perceptible to the average ear.

This means, then, that the output power from the 18 watt amplifier is only four perceptible steps louder (not four times louder) than a single pentode. So much for the power output question, although if desired the amplifier could be run at from 10 to 12 watts output (with a consequently less perceptible difference from the single pentode amplifier) with reduced harmonic distortion.

It represents a better economic proposition than an amplifier using a pair of 2A3's, is more robust in design, and is tonally equal to the best of the standard triode amplifiers.

The Components Used

In an amplifier of this type it is imperative that strict attention be paid to

the specifications of the various components. Failure to follow this instruction will assuredly result in failure to obtain the excellent results which were obtained from the original.

The audio transformer, AFT, must be specially designed. It has a primary inductance of from 10 to 15 henries and is capable of carrying the 31 Milliampere plate current required by the audio driver tube, V2. This transformer must have a step down ratio which from the primary to one half of the secondary is equal to 1.6. For best results the secondary should be wound in two symmetrical sections so wound and mounted that the two inside connections can be joined together and to the source of bias voltage, whilst the remaining outside connections go to the amplifier grids. The original transformer was specially built for us by the Airmaster Radio Co., and had a frequency response which was aurally flat from 50 to 12,500 cycles.

The various condensers used in the amplifier all were of the highest grade. The tubular condenser, C2, the 4 mfd. paper condenser C3, C4, C5 and C6, and the 25 mfd, 25 volt electrolytic condenser, C1, all were of T.C.C. marque, whilst the 8 mfd. 600 volt electrolytics, E1, E2 and E3, were Solars. C3, C4, C5 and C6 should be 250 v. a.c. working types whilst the .1 mfd. condenser, C2, should be a 300 volt d.c. type.

These chokes and the power transformer, PT, constitute one of the most important parts of the amplifier so should be given special attention. The filter

PARTS LIST AND SCHEMATIC CIRCUIT DIAGRAM

for The Listener In High Fidelity Amplifier

AC: Polarised Plug and socket. (Marquis).

AFT: Special Class AB Push-Pull

Transformer. (Airmaster Radio, H.F.4).

C1; 25 mfd 25 volt test electrolytic condenser. (T.C.C.)

C2; .1 mfd condenser. (T.C.C.)

C3, C4, C5, C6; 4 mfd 250 volt AC working test. block condensers (T.C.C.)

CH1, CH2; Special low resistance filter chokes. (Airmaster Radio types H.F. 3A, and H.F. 3B).

E1, E2, E3; 8 mfd 600 volt test electrolytic condensers. (Solar).

LS: High Fidelity Speaker. (Amplion or Rola G.12).

PT: Power Transformer delivered 500-0-500 at 150 m.a., 5 volt at 2 a., 1.5 volt at 1 a., and two 6.3 volt windings. (Airmaster Radio type H.F.2 Stedi-Power).

R1, R4; .5 megohm resistors. (I.R.C.)

R2; 10,000 ohm resistor (I.R.C.)

R3; 1 megohm resistor. (I.R.C.)

R5; 30,000 ohm W.W. resistor (Stedi-Power).

R6; 3000 ohm W.W. resistor. (Stedi-Power).

R7; 15,000 ohm W.W. Voltage divider. (Stedi-Power).

Valves: One 75, three 42's, one 5Z3, and one 26 with sockets to suit. (Radiotron).

Sundries: Chassis measuring 15 inches by 12 inches by 3 1/2 inches (Airmaster Radio) belden wire, two terminals, speaker and input sockets, grid clips, machine screws and nuts, etc.

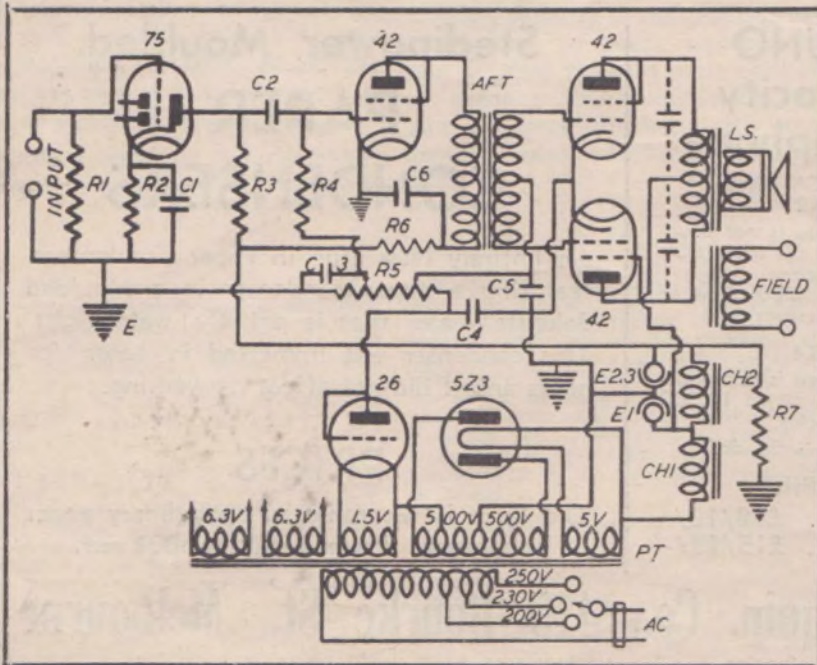

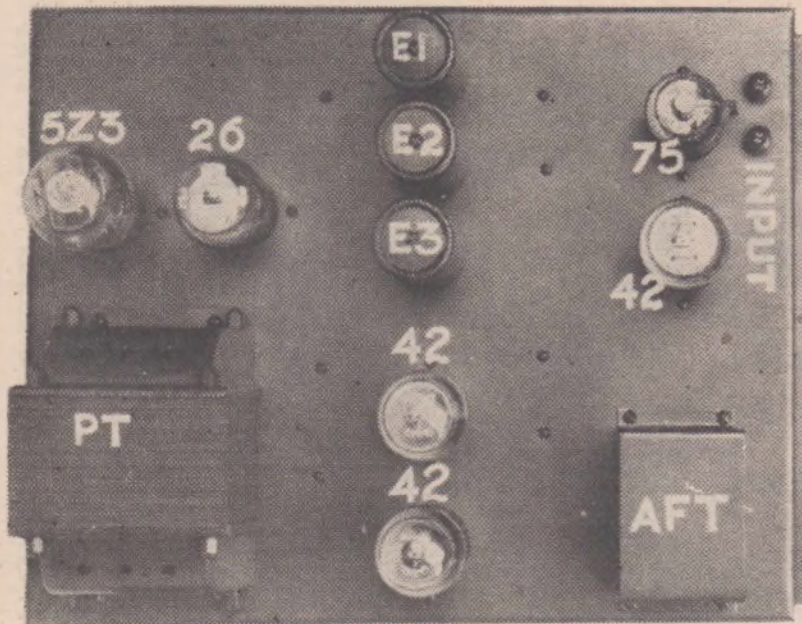

This plan view of the amplifier shows the arrangement of parts on top of the chassis. All parts are keyed to correspond with the written description of the amplifier.

choke, CH1, is intended to carry peak currents up to 150 m.a. and, in order to conserve as much as possible of the available supply voltage from the rectifier, its d.c. resistance must be low. This low d.c. resistance also is important from the viewpoint of voltage regulation.

It also is necessary, from the filtration viewpoint, that the inductance of the choke be as high as practicable. That used in the original amplifier had an inductance of 10 henries and a d.c. resistance of only 100 ohms.

The second choke, CH2, is almost as important, for conditions can arise where it is called upon to carry some 60 or 70 m.a. to supply a powerful receiving set. Its inductance is necessarily higher, about 30 henries, but its d.c. resistance must not exceed 300 ohms. The power transformer itself presents quite a complicated design problem.

The total current required from the high voltage secondary is 150 m.a. peak, whilst the maximum a.c. output voltage must be 500. In addition, the high voltage secondary must be provided with a 60 volt tap on one side of the centre tap in order to operate the Type 26 bias rectifier. Four filament windings, two of which are for the 6.3 volt valve filaments, one for the 5Z3 high voltage rectifier, and one 1.5 volt winding for the bias rectifier also are required.

One of those 6.3 volt windings has an output current of 2.4 amperes, sufficient to supply the four amplifier valves. The other should have a maximum current output of 1.5 amperes, to supply a maximum of five 6.3 volt type valves in any receiver which is to precede this amplifier. Like the audio transformer, the filter chokes and power transformer were specially built by the Airmaster Radio Co.

Resistors

The only other components which require particular mention at this juncture are the resistors and the valves. The resistors R5, R6 and R7 are of the wire wound type. R5 is a 30,000 ohm

voltage divider used across the output of the 26 rectifier. R7 is an 15,000 ohm voltage divider used across the output of the filter circuit, whilst R6 is a voltage dropping resistor in series between the maximum supply line and the primary of the audio transformer, AFT. The remaining resistors are of the metal-lised type. R1 and R4 are the conventional .5 megohm grid resistors, whilst R2 is a 10,000 ohm cathode bias resistor for the first tube.

Valves

The valves used in the amplifier are all Australian-made Radiotrons. The first tube, a 75, is a diode triode. The second is a 42 type pentode operated as a triode with its plate and screening grid connected together. The final stage tubes are similar type 42's, also operated in triode connection. The high voltage rectifier is a 5Z3, whilst the bias rectifier is a type 26, chosen because of its directly heated filament, which ensures that correct bias will be available for the amplifier tubes even during their warming up period.

Having dealt with the salient characteristics of the component parts, we shall go on to a description of the layout and general arrangement. The amplifier is built up on a steel chassis measuring 15 inches in length, 12 inches in width, and 3½ inches in depth. The key-lettered top view of the original chassis shows clearly the general arrangement of the component parts. It is worthy of note, however, that the filament lugs of the two rectifier valve sockets face the power transformer, PT, whilst the filament lugs of all other sockets face the power transformer end of the chassis.

In the rear right hand corner of the illustration the two input terminals can be seen. One of these, the grid terminal, is insulated from the chassis. On the end of the chassis below these input terminals is the five pin socket which is intended to provide an easy means of plugging a radio receiver into the amplifier in such a way that the receiver

will draw its power supply from the amplifier. On the rear of the chassis is mounted (centre) the five pin loud speaker socket and (beneath the power transformer) the Marquis polarised plug used for the a.c. supply inlet. The underneath view of the chassis shows that the lay-out of components is quite straightforward.

At the right can be seen the two rectifier valve sockets. Behind them is the first filter choke CH1, mounted to the side of the chassis. Between the first and second filter chokes is the 4 mfd. condenser, C5, the 30,000 ohm resistor, R5, being secured to the chassis between this condenser and the second 4 mfd. condenser, C3. In the left hand front corner of the chassis illustration will be seen the third 4 mfd. condenser, C4. The fourth, C6, had not been fitted to the amplifier when this photograph was taken, but was mounted on the under side of the chassis between the loud speaker socket and C4.

The 3000 ohm resistor, R6, can be seen above the audio transformer connection strip. To the right of this strip is the 15,000 ohm voltage divider, R7, and, in the rear left-hand corner, are the sockets, condensers, and resistors, for V1 and V2. The assembly of the components is quite simple, but there are one or two points worthy of note. The Airmaster filter chokes are provided with mounting brackets which apparently are short of actual requirements. This has been done purposely so that, by placing a washer between the securing nut and the side of the mounting brackets, it is possible to "pull" these down tightly on the chassis thus holding the choke coil cores tightly together and so preventing "rattle" when the amplifier is running.

The power transformer connections are as shown in Fig. 1 where it will be noticed that a common centre tap is provided for the valve lighting filaments and the high voltage secondary. The electrostatic screen also is connected to this lug which should be earthed to the chassis. The connection from the 60 volt secondary tap on the high voltage winding to the filament for the 26 bias rectifier is made internally so that all that is necessary is to take the 1.5 volt filament lugs to the corresponding lugs on the socket for the 26.

The leads to the audio transformer are color coded for ease of connection. The code is as follows:—Red to plate of the driver 42; Orange to "B" positive through the resistor, R6; Blacks connected together and to the 38 volt tap on the resistor, R5; Blues to the grids of the push pull 42's.

A brief wiring description is as follows:—Start by twisting together a pair of wires which are soldered to the 6.3 volt 2.5 ampere lugs on the power transformer. Take these wires to the filament lugs on all four valve sockets. Next join the 5 volt lugs on the power transformer to the filament lugs on the 5Z3 socket and do likewise with the 1.5 volt lugs and the 26 socket. A pair of wires should be run from the remaining 6.3 volt lugs to the filament lugs on the five pin input socket below the input terminals.

Connect the two high voltage secondary lugs on the power transformer to the plate and grid lugs on the 5Z3 socket and join the common centre tap lug to chassis. Take the common input lug on the transformer to one of the lugs on the Marquis plug and connect the other

lug on this plug to the requisite voltage lug on the transformer primary. Join one lead of CH1 to one filament lug on the 5Z3 socket and take the other lead on this choke to one lead on CH2 and to the positive lug on E1.

The remaining lead on CH2 joins to the positive lugs on E2 and E3 and to one side of the voltage divider, R7. The other side of R7 is grounded. Next connect together the plate and grid lugs on the 26 socket and take them to one lug on C5 and one lug on R5. The remaining lug on C5 is grounded, as is the other end of R5.

Join the centre tap, Black, lead from AFT to one lug on C4 and to the clip on R5 nearest to the negative (un-earthed) end. The remaining lug on C4 is grounded. Take the two Blue leads on AFT to their respective grid lugs on the output 42's and join the Red lead to the Plug on the driver 42. The screening grid lug on this valve is joined to the plate lug on this socket, the same procedure being adopted with the plate and screening grid lugs on each of the push pull tube sockets. The cathode lugs on these latter tube sockets are connected to ground. The combined plate and screen grid lugs on one output 42 are joined to the cathode lug on the speaker output socket, whilst a corresponding connection is run from the other output 42 to the plate lug on the output socket.

The grid lug on this output socket carries a lead which joins to the positive lug on E1. From the positive end of R7 a lead is taken to one side of the 3000 ohm resistor, R6, the other side of which is joined to one lug on the 4 mfd. condenser, C6, and to the Yellow lead from AFT. The vacant lug on C6 goes to ground. A cathode lug on the driver 42 socket joins to ground. The .1 mfd. condenser, C2, is connected between the triode grid of the 75 and the control grid of the driver 42. From the control grid of this tube a lead is taken to one end of the 500,000 ohm resistor, R4, the other end of which goes the clip on R5, which is nearest to the earthed end. This clip carries a lead which goes to one lug on C3, the other lug of which is grounded.

From the plate lug on the 75 is connected one lead of the .1 megohm resistor, R3, the other lead of this resistor going to the maximum potential on the voltage divider, R7. The control grid of the 75 is joined to the insulated input terminal on the chassis which carries also one lead of the 500,000 ohm resistor, R1. The other lead of R1, one lead of R2, and the negative lug on C1, are joined to ground. The remaining lead on R2 and the vacant lug on C1 are soldered to the cathode lug on the socket for the 75. This completes the actual wiring of the amplifier.

We now will deal with points on its operation. First, it is advisable to have the 42 output tubes matched for plate current at working conditions, i.e., 350 volts plate and -38 volts grid, and at some more positive bias voltage such as -15 volts. This matching, however, is not absolutely necessary.

Correct operating voltages are: Output tube plates to earth 350 volts; AFT centre tap to ground -38 volts; driver 42 plate to ground 250 volts; R5 end of R4 -20 volts. Adjustments to these bias voltages for the driver 42 and the push-pull 42's will, naturally, be made by sliding the clips along R5; remem-

bering, of course, that the earth end of R5 is positive.

During these preliminary adjustments, and in fact at all times, it is advisable to insert a standard flashlight bulb between the rectifier filament and CH1. This will act as a fuse so that in the event of a failure of the bias supply the disastrous effect of such a high plate potential on un-biased valves will be eliminated.

There is one point which must be made specially clear. The original specifications for the power transformer for this amplifier called for a current drain of 40 milliamperes more than the amplifier takes in its present form. This was done to allow a fairly powerful radio receiver to be used ahead of the amplifier.

Naturally, with the reduced current drain, the output voltage rises, so it has been necessary to include R7, as a voltage divider, to simulate at least some of the proposed extra drain and to use R6 in order to reduce the available potential to the correct value. 250 volts, for the driver 42.

With suitable extra current drain as furnished by a standard three or four valve receiver, these resistances can be eliminated. Meantime it is essential that they be kept in circuit. It also is imperative that R6 be by-passed by a 4 mfd. condenser, C6, otherwise the low frequency response of the amplifier will depart seriously from that of the original.

There is another way in which the excess voltage can be dissipated. In the original amplifier we used a Rola G12 High Fidelity loud speaker which is provided with a 3500 ohm field. This loud speaker requires a minimum of 14 watts for its field excitation. Other high fidelity loud speakers, including the Amplion, have similar field requirements so that the field of the Rola, the Amplion, or some similar type of speaker could be rewound to 10,000 ohms and connected between the 5Z3 filament and ground. Failing this, a permanent magnet type Amplion could be used.

The original Rola loud speaker was, in our case, separately excited, but no ill effect would accrue from following the suggestion set out above. It is impossible, however, to attempt to use the speaker field as a filter choke.

Another feature which comes up for attention is the question of parasitic oscillation. This tendency is always present in the case of amplifier valves which draw grid current at the positive signal swings. Its presence may be detected by connecting an 0-50 milliammeter in each of the cathode leads and feeding a gradually increasing 1000 cycle signal into their grids. As the signal voltage is increased the plate currents of both tubes should increase approximately to the same degree. If one meter shows an increase and the other a decrease or no appreciable increase, parasitic oscillation is present. It may be eliminated by connecting a .004 mfd condenser between each 42 plate and the centre tap of the output transformer or between each plate and earth.

Thanks to the valuable co-operation of Mr F. Canning, of Airmaster Radio, practically no experimental work was necessary with the original amplifier because the design of the principal components, including the audio transformer, power transformer, and filter chokes, was ideal for the job.

The original amplifier set-up, however, employed a type 76 triode as pre-amplifier but it was found that insufficient gain could be obtained. Fully to load the output valves it was necessary to turn to the high- μ diode-triode 75, which had a working μ of 39 against the working μ of slightly more than 9 under the conditions of the 76 that was being used.

With the 76 pre-amplifier the overall voltage gain of the amplifier was nearly 48 db, but with the inclusion of the 75 the overall gain rose to over 60 db. The inclusion of the 75 reduced the high note amplification slightly but this could quite easily be remedied by reducing the plate coupling resistor value.

(Continued on Page 86)

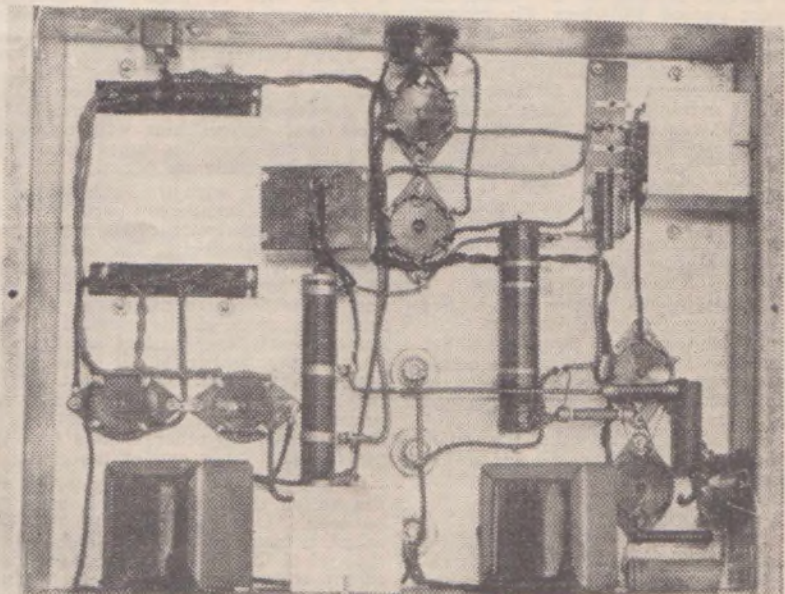

An underneath view of the completed amplifier. This photograph illustrates the wiring and mounting positions of the various components below the chassis.



THIS little Raytheon family has come to offer you its services. Take advantage of this opportunity to improve your staff. Both branches of the Raytheon family—all-metal and glass—have met with tremendous success and popularity overseas and come to Australia with wonderful credentials. In addition, each has to go through a most gruelling individual test directly on landing, which test very few fail to pass.

Each member handles perfectly the specialised job for which it is famous, the improvement of radio reception, elimination of all distortion and general valve troubles.

Many local manufacturers, realising their worth, have placed these Raytheons in set sockets and found, as a result, that the quality of production has increased and their sales have soared.

Don't be blind to their qualities—let them in.

Raytheon four pillar valves and Raytheon metal valves are contained in a special testing carton which allows them to be set-tested, hot and cold, in Australia before despatch to dealer or set manufacturer.

RAYTHEON

GLASS AND METAL VALVES

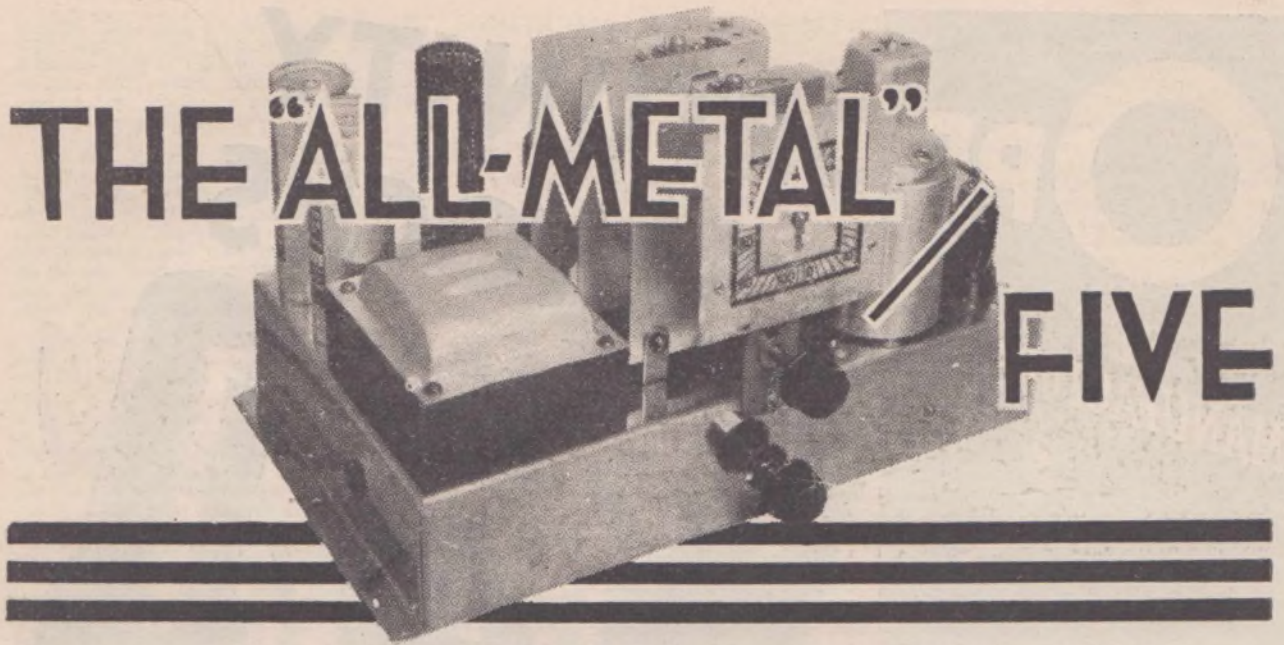

An Ultra-Modern Super-heterodyne Receiver which employs High Selectivity I.F. Transformers, All Metal Valves, and a Novel Overload Control.

By A. K. BOX

THE technique of radio receiver design is advancing at a pace which is almost bewildering. New valve types have made it possible to employ circuit refinements which, if they do much to enhance the pleasure of listening, also involve considerable complication both in the design and in the construction of receivers. Such features as automatic volume control, muting, variable band width, and automatic tone compensation are certainly well worth-while, but to the novice set constructor they present extreme difficulty.

However, there are many radio set building avenues which this individual may explore with the fore-knowledge that his efforts will not be wasted and that they will result in the development of

highly satisfactory receivers. An example is furnished in the case of the present receiver which, although it embraces really modern design principles, is both simple to construct and easy to get going.

The receiver is ultra-modern; in fact, it follows closely, although unintentionally, the design of one of this year's model released by the famous Radio Corporation of America. The answer to the sceptic who may consider that "there are not enough bits in it" is that if this type of circuit is considered by one of the leaders in the world of technical radio to be suitable for American conditions, there cannot be very much wrong with it. The contention was fully proved during our tests of the original model.

aerial and oscillator circuits, is effected with the aid of the padding condenser, PD, connected between L4 and earth. Bias for the oscillator grid is furnished by the 50,000-ohm resistor, R1, connected between the oscillator grid and cathode of the 6A8. The oscillator plate coil, L3, is connected between the oscillator plate and the 200-volt tap on the voltage divider, VD. The "B" supply side of this coil is by-passed to earth with the .1 mfd. condenser, C3.

The cathode of the 6A8 is biased by means of the 300-ohm fixed resistor, R2, which is connected to the arm of the volume control, VC, so that an increasingly negative voltage can be applied to this tube to reduce the volume on local stations. The .1 mfd. condenser, C2, acts as a radio-frequency by-pass from cathode to earth. The screening grid of the 6A8 requires a potential of 100 volts. As the other two r.f. tubes, the 6K7 and 6J7, require a similar screen potential, the three are connected together and by-passed to earth with the .5 mfd. condenser, C5.

The necessary screen voltage is obtained from a tapping on the voltage divider.

The plate of the 6A8 feeds through the primary of the first i.f. transformer to the 250-volt tap on the voltage divider, VD. IF1 and IF2 are the new type high-gain, high-selectivity transformers developed by Radiokes. These transformers, being of the litz-wound type, are inherently more efficient than ordinary type i.f. transformers. The low r.f. resistance of the litz wire improves the selectivity as well as the gain of the transformers, and the coupling between the two coils has been decreased still further to improve this selectivity. The result is that, although possessing more than sufficient manageable gain,

GLANCE at the schematic circuit diagram whilst we run through the salient characteristics of this interesting all-metal super-het. The aerial unit, AER, comprising the primary coil, L1, and the secondary, L2, is coupled to the grid of the 6A8 mixer valve. The secondary, L2, is tuned by the G1 section of the gang condenser. The 6A8 metal valve is a mixer type tube similar in design to the 2A7 and

6A7. Full details as to its characteristics and those of the other valves in the receiver will be found elsewhere in this issue.

The oscillator section of the 6A8 has its oscillator grid connected through the .0001 mfd. condenser, C1, to the secondary, L4, of the oscillator grid coils, OSC. This coil is tuned by means of the G2 section of the two-gang condenser. Tracking, i.e., ganged tuning of the

the Radiokes intermediate frequency transformers provide REAL selectivity, a feature which hitherto has been difficult of attainment without the use of complicated circuits.

The grid of IF1 is coupled to the control grid of the 6K7 metal tube intermediate frequency amplifier. This tube is similar in design and operation to the 6D6 or 58. The cathode of the 6K7 is biased by means of the 350-ohm resistor, R3, which, like the 6A8 cathode resistor, R2, is returned to the arm of the volume control, VC. The cathode of the 6K7 is provided with a radio-frequency by-pass in the form of the .1 mfd. condenser, C4. The resistance element of VC is connected between the 50-volt tap on the voltage divider and ground so that it becomes possible, by adjustment of the moving arm, to apply a negative bias ranging from a "zero" of 3 volts (fixed by the resistance R2 and R3) to 50 volts maximum to the control grids of the mixer and i.f. tubes. This gives ample control of volume. prevents blasting on local stations, and permits the amplification of the set to be limited for local listening so that outside electrical noise will not mar reception.

The plate of the 6K7 feeds to the maximum "B" tap of 250 volts through the primary of IF2. The secondary of IF2 feeds into the control grid of the 6J7 r.f. pentode. This valve has been used as a biased second detector because, in the new metal series, there is no combined diode-triode or diode-pentode valve. If we employed the 6H6 diode the tone qualities of the receiver might be slightly better, but we then would find it necessary to employ an additional triode or pentode valve as an audio-frequency amplifier between the diode and the final audio tube.

The anode-bend-operated 6J7, however, functions well as a second detector, is more sensitive than the diode, and is certainly more selective, due to the fact that its input circuit load is less than that of a diode. With this type of second detector it is not possible to apply true automatic volume control. On the other hand, receivers of this type are employed mainly for local reception.

In such circumstances what is wanted is not automatic VOLUME control, but automatic OVERLOAD control. The latter feature is ingeniously arranged by connecting the grid return of the second-

ary of IF2 to earth through a high resistance. R4, which serves this purpose, has a resistance of one megohm. The principle of the arrangement is that when the detector reaches the overload point, due to the strength of the incoming signal, it begins to draw grid current. Current flowing through the resistance, R4, introduces a voltage drop across this resistor, with the result that a negative bias is applied to the control grid of the 6J7, thus preventing the overload from taking place.

This control has been extended, in the form of a modified automatic volume control, to the control grid of the 6K7 by connecting the grid return of IF1 to the IF2 side of the resistor, R4, so that the 6K7, too, is fed with an increased negative bias when the overload point is reached. The system operates very well and permits the second detector to drive the pentode output tube to full output power without setting up distortion.

The fixed condenser, C6, has a capacity of .1 mfd., and is used for the purpose of providing a radio-frequency earth return for the grids of the 6K7 and 6J7. The Cathode of the 6J7 is biased by means of the 10,000-ohm resistor, R5, which is by-passed by the 25 mfd. electrolytic

SCHEMATIC CIRCUIT DIAGRAM AND COMPONENT LIST for "The All-Metal Five"

AER, OSC.—465 k.c. Aerial and Oscillator Coils (to match tuning condenser).

C1.—.0001 mfd. Mica Condenser.
C2, C3, C4, C6. — .1 mfd. Tubular Condensers.

C5, C13. — 5 mfd. Tubular condensers.

C7, C11.—25 mfd. 25 Volt Electrolytic Condensers.

C8, C9.—.0002 mfd. Mica Condensers.
C10, C12.—.02 mfd. Mica Condensers. (All T.C.C.)

CHASSIS. — Aluminium, 16 gauge, measuring 13 inches by 8 inches by 2½ inches.

E1, E2.—8 mfd. 600 Volt Electrolytic Condensers.

G1, G2. — Two Gang Tuning Condenser to suit Coil Kit.

IF1, IF2.—465 k.c. High Gain Intermediate Frequency Transformers.

LOUD SPEAKER.—1500 Ohm Field, Input to suit 6F6. (Amplion, Rola).

PD.—465 k.c. Padding Condenser.

PT.—Power Transformer: 385-0-385v. at 75 m.a.; 5 v. at 2 a. and 6.3 v. at 2 a. C.T.

R1.—50,000 Ohm Resistor.

R2.—300 Ohm W.W. Resistor, 10 m.a.

R3.—350 Ohm W.W. Resistor, 10 m.a.

R4.—1 Megohm Resistor.

R5, R9.—10,000 Ohm Resistors.

R6.—500,000 Ohm Resistor.

R7.—250,000 Ohm Resistor.

R8.—450 Ohm W.W. Resistor, 50 m.a.

R10.—1500 Ohm W.W. Resistor, 100 m.a. (All I.R.C.)

VALVES. — One Each Metal Type.

6A8, 6K7, 6J7, 6F6, and 5Z4, with sockets to suit. (Mullard, Philips, Radiotron, Raytheon).

VC.—10,000 Ohm Potentiometer.

VD.—25,000 Ohm Voltage Divider.

SUNDRIES.—Wire, Machine Screws, Terminals, I.S. Socket, Miniature Grid Clips, Solder, Lugs, etc.

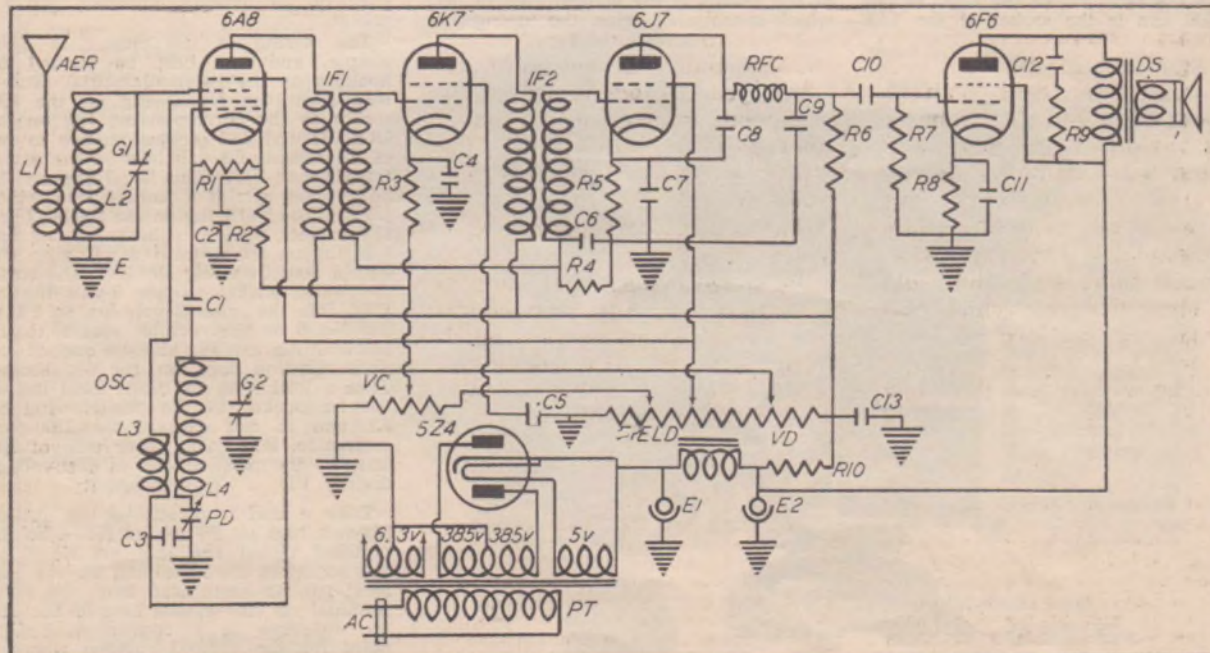

condenser, C7. The plate of the 6J7 feeds to the audio tube filter through the r.f. filter network consisting of RFC, C8, and C9. The 6J7 derives its plate supply through the 500,000-ohm resistor, R6, which is connected to the 250-volt tap on the voltage divider, VD. The grid of the audio tube is coupled to the 6J7 plate through the .02 mfd condenser, C10. Bias for the 6F6 audio tube is derived from the 4505-ohm cathode resistor, R8, which is by-passed by the 25-mfd. electrolytic condenser, C11. The conventional tone compensating circuit, comprising the .02-mfd. condenser, C12, and the 10,000-ohm resistance, R9, is connected between plate and screening grid of the 6F6.

Under the operating conditions we planned to use the 6F6 in this circuit, it is necessary that it receive a plate potential of 315 volts. As the remainder of the tubes in the receiver require a maximum potential of 250 volts, it is essential that some dropping resistance be incorporated between the maximum supply voltage and the voltage divider, VD. This is the resistance R10, which has a value of 1500 ohms. Under these operating conditions the pentode delivers a power output of 5 watts at an harmonic distortion of only 7 per cent. The loud speaker field has a resistance of 1500 ohms, the speaker being designed to operate with a field excitation in the vicinity of 11 watts.

The power supply circuit is quite conventional except, perhaps, for the fact that the 5Z4 rectifier has an internally connected pair of cathodes.

Having dealt with the salient circuit details of the receiver, we can proceed now to a description of the set's construction, its wiring, its adjustment and its final operation.

The receiver is built up on an aluminium chassis measuring 13 inches in length, 8 inches in width, and 2½ inches in depth. As can be seen from the key-lettered illustration of the completed set, the lay-out is quite conventional. The gang condenser, G1, G2, is mounted centrally on the chassis. To the right of this condenser can be seen the AER and OSC coils, the latter being nearest to the front of the chassis. To the right of the OSC coil can be seen the socket of the 6A8

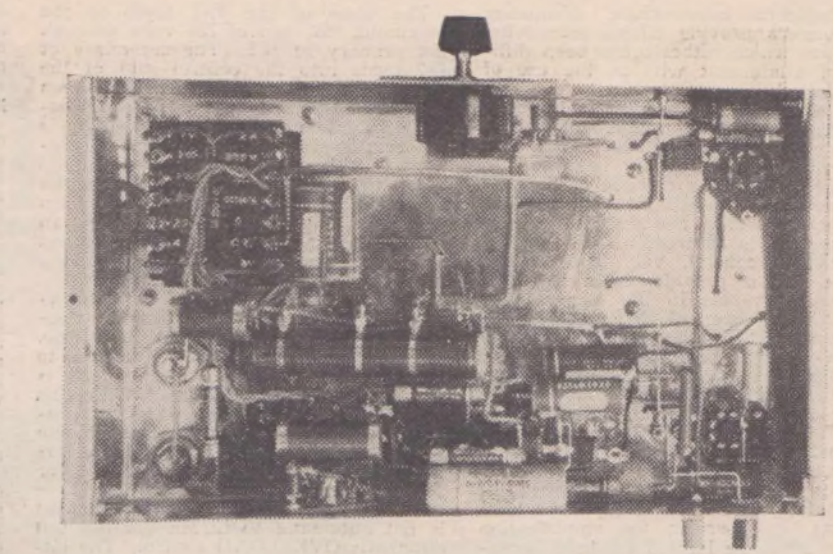

An underneath view of "The All-Metal Five," which shows that very few components are needed for its construction.

mixer valve, whilst alongside the AER can is to be seen the can which houses IF1.

The intermediate frequency amplifier tube, 6K7, is to be found in the right-hand rear corner of the chassis. To the left of this tube is the second i.f. transformer, IF2, and to the left of IF2 the second detector tube, 6J7. Continuing towards the left we have the 6F6 audio tube and the 5Z4 rectifier tube in the order mentioned.

Along the left-hand end of the chassis are to be found the two electrolytic condensers, E1 and E2. It is important, on account of the heat emitted by these metal type valves, to keep the electrolytic condensers well away from them. The power transformer, PT, is to be found in the front left-hand corner of the chassis. The only control, besides the tuning dial, to be found on the front of the chassis is the volume control, VC, which is mounted below the tuning dial.

Along the back of the chassis we find the aerial and earth terminals, below the 6K7 socket and the l.s. socket, below the 6F6 socket. The power supply leads can be brought through a rubber grommetted hole either in the side or the rear of the chassis.

An underneath view of the finished set shows that, with the exception of the voltage divider, VD, the padding condenser, PD, and the fixed condenser, C12, the components are wired directly into circuit. PD is mounted underneath the front of the chassis so that its adjustment screw is reached by means of a hole between the gang condenser and the oscillator coil can. The voltage divider is mounted parallel with the sides of the chassis and just to the rear of the power transformer. The fixed condenser, C12, is bolted to the rear edge of the chassis alongside the l.s. socket.

The wiring of the circuit is quite simple, and can best be started by hooking up the valve filaments. Run a lead from the No. 2 lug on the 6A8 socket to the corresponding lug on the 6K7, 6J7 and 6F6 sockets, thence to one of the outside 6.3 volt lugs on the power transformer, PT. The No. 7 lug on the 6A8 socket carries a similar lead which joins to the No. 7 lug on the 6K7, 6J7 and 6F6 sockets, thence to the remaining outside lug on the 6.3 volt winding on PT. Run a lead from lug No. 2 on the rectifier valve socket to one 5-volt lug on PT. Join the other 5-volt lug on PT to lug No. 8 on the rectifier socket, to the positive lug on E1, and to one of the field winding lugs on the l.s. socket. Take a lead from the other field lug on the l.s. socket to the positive lug on E2, and to one side of the 1500-ohm resistance, R10. The other side of R10 joins to the positive end of the voltage divider VD.

Take a lead from one of the outside 385-volt lugs on PT to lug No. 4 on the rectified socket and join lug No. 6 on this socket to the remaining 385-volt lug. Next run an earth lead from the earth terminal on the chassis around the latter to serve as a convenient anchor point for the various earthed components, and to the centre-tap of the 385-volt winding on PT. Join to this earth lead

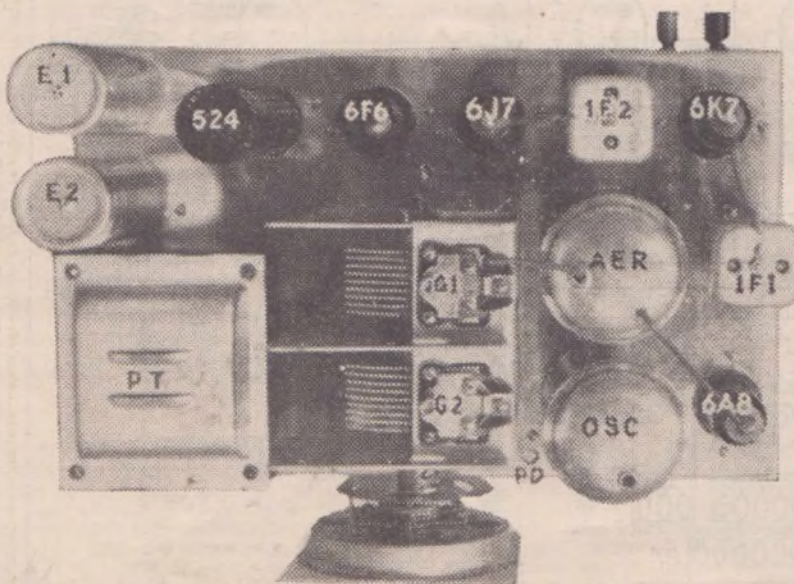

This lettered top view of the completed receiver should be studied in conjunction with the wiring description.

R O L A

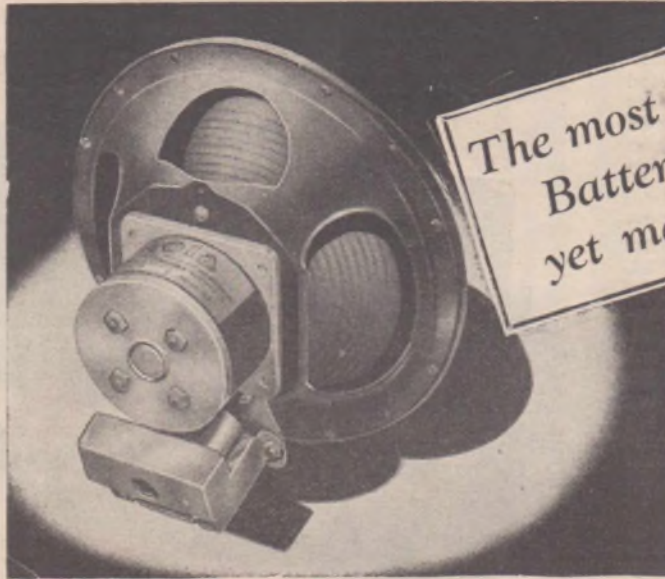

The most outstanding
Battery Speaker
yet manufactured

Made by the
Manufacturers
of the World's
Finest Sound
Reproducers

P.M. 8-20

The Rola P.M. 8-20 features among others these notable improvements. A new design Permanent Magnet, entirely redesigned Diaphragm, Patented Rola Dust-proof Air Gap and Sealed Transformer.

Ask your dealer for a demonstration of the P.M. 8-20, and prove for yourself its many fine features. The world-famous Rola range includes the K7, F6 and DP5B.

ROLA COMPANY
(Aust.) Pty. Ltd.
81-83 City Rd.,
Sth. Melb., S.C.A.

INTRODUCING THE NEW EFCO DIALS

"EDGE-LIGHTING"

THE NEW No. 38 BAND SPREAD DIAL

Which enables the operator to accurately log by means of a "split second" hand, local and overseas stations, and to repeat this procedure easily by means of the "Bandspread" pointer.

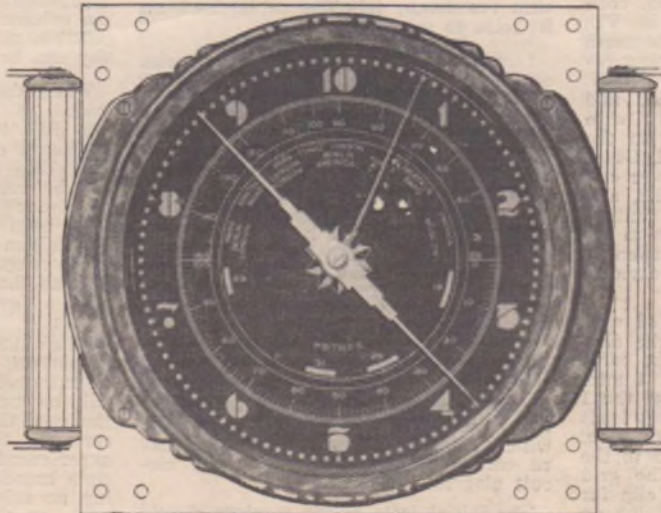

The escutcheon illustrated is No. 16. The window size is 5½ in. Ratio: White Pointer 16-1. Red Pointer to White—8-1.

This dial can be supplied in one, two and three glasses, giving vari-colored effect.

Price:

- One glass—28/6
- Two glass—30/6

PATENT NO 25509/35



Wholesale from
O. H. O'BRIEN
Bourke Street, Melbourne

the 6.3-volt centre-tap lug and lug No. 1 on the rectified socket. Take the free end of VD to the earth wire. Join the aerial lead on L1 to the aerial terminal on the chassis and join the earth lead from both L1 and L2 to earth. Join the grid end of L2 to the fixed plate lug on the G1 section of the gang condenser and attach to it a lead which will carry the control grid clip for the 6A8.

Solder the plate lead from 1F1 to the No. 3 lug on the 6A8 socket. Attach the grid lead of the oscillator grid coil, L4, to one lug of the .0001-mfd. condenser, C1, and join the other lug on this condenser to lug No. 5 on the 6A8 socket. To this lug on the 6A8 socket solder one lead of the 50,000-ohm. resistance, R1. The other lead, on R1, is soldered to lug No. 8 on the 6A8 socket, as also is lug No. 1 and one lead of the .1 mfd. condenser, C2, and one lead of the 300-ohm resistance, R2. The other lead on C2 goes to earth.

Take a lead from the fixed plate lug of the G2 section of the gang condenser to the grid end of L4. The earth end of L4 joins to one side of the padding condenser, PD. the other lug on which is connected to the earth wire. Lug No. 4 on the 6A8 socket carries the screening grid lead which is joined to lug No. 4 on the 6K7 and 6J7 sockets. From the latter socket the lead runs to the 100-volt tap on the voltage divider, VD.

The No. 4 lug on the 6K7 socket carries on lead of the .5 mfd. condenser, C5, the other lead of which joins to the earth wire. The plate lead of the oscillator plate coil, L3, joins to lug No. 6 on the 6A8 socket. The other end of L3 is soldered to one lead of the .1 mfd. condenser, C3, and joins to the 200-volt tap on the voltage divider, VD. The other lead on C3 goes to earth.

The "B" plus lead from IF1 is joined to the corresponding lead on IF2, and taken to the 250-volt tap on the voltage divider. One lead of the .5 mfd. condenser, C13, is joined to this tap on VD, the other lead of C13 going to the earth wire. Join one lead of the 350-ohm resistance, R3, and one lead of the .1 mfd. condenser, C4, to the lugs Nos. 1 and 8 on the 6K7 socket, and run a wire from this lug to the No. 5 lug on the same socket. The free end of C4 is joined to the earth wire. The free end of R3 joins to the free end of R2, and to the arm lug on the volume control, VC. One outside lug on VC joins to the earth wire, whilst the other is taken to the 50 volt tap on the voltage divider, V.D.

The grid lead on IF1 is provided with a clip for the control grid of the 6K7. The earth lead on IF1 joins to the earth lead on IF2, to one lead of the .1 mfd. condenser, C6, and to one lead of the 1 megohm resistance, R4. The vacant leads on C6 and R4 join to the earth wire. The plate lead from IF2 is wired to the No. 3 lug on the 6K7 socket. The grid lead on IF2 is provided with a clip for the control grid of the 6J7. One lug on the radio frequency choke and one lug of the .002 mfd. condenser, C8, are joined together and taken to the No. 3 lug on the 6J7 socket. The other lug on C8, one lead on the 10,000 ohm resistance, R5, and the positive lead on the 25 mfd. electrolytic condenser, C7, all are joined to the No. 8 lug on the 6J7 socket, from which a lead is taken to the No. 1 and

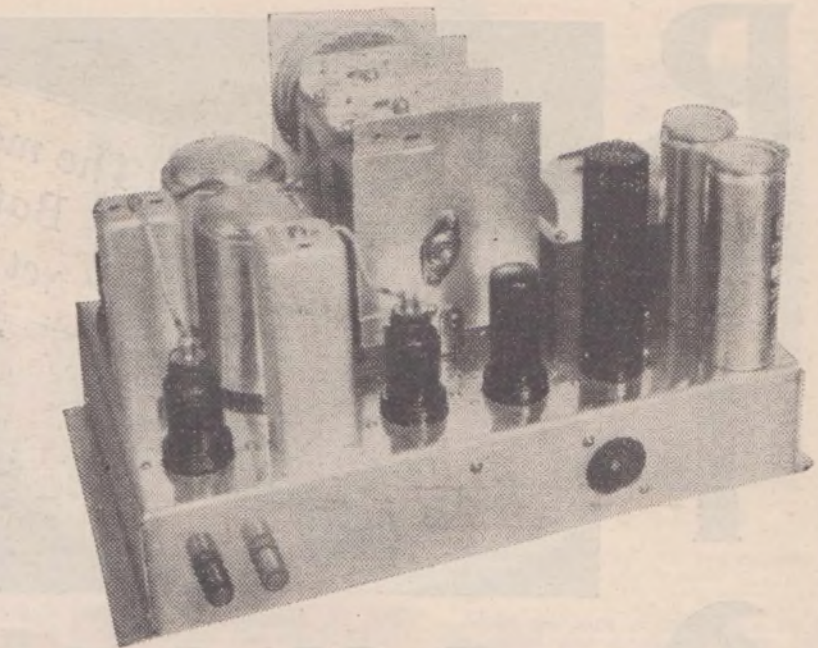

Compact in lay-out and handsome in appearance, "The All-Metal Five" is a receiver to gladden the heart of the set-builder.

No. 5 lugs on the same socket. The remaining leads on the C7 and R5 join to the earth wire.

The vacant lug on RFC carries one lug of the .0002 mfd. condenser, C9, and one lead of the 500,000-ohm. resistance, R6. A lead is taken from this same point on RFC to one lug of the .02 mfd. condenser, C10. The vacant lug on C9 joins to the earth wire, whilst the remaining lead on R6 goes to the 250 volt tap on the voltage divider, VD. The vacant lug on C10 is connected to lug No. 5 on the 6F6 socket, to which lug also is soldered one lead of the 250,000-ohm resistance, R7. The other lead on R7 joins to the earth wire.

Lug No. 8 on the 6F6 socket carries one lead of the 450 ohm. resistor, R8, the positive lead of the 250 mfd. electrolytic condenser, C11, and a lead to lug No. 1. The vacant leads on each of these components join to the ground wire. Lug No. 4 on the 6F6 socket joins to one of the input transformer lugs on the l.s. socket. This lug on the speaker socket is joined to the field lug on the same socket which already is wired to E2. Lug No. 3 on the 6F6 socket joins to the remaining input transformer lug on the l.s. socket, and to one lug of the .02 mfd. condenser, C12. The other lug on C12 carries one lead of the 10,000-ohm resistance, R9. The remaining lead on this resistance joins to the l.s. socket lug, which is carrying the lead to E2. This completes the wiring of the receiver, which upon completion should be checked carefully against the schematic circuit diagram.

The initial tests of the receiver should aim at fixing the operating potentials at their correct values. The plates of the 6A8, 6K7 and 6J7, all should receive a potential of 250 volts, when no signal is being received, and the volume control is in the maximum position. The screening grids of these three valves should receive 100 volts. The volume control should be tapped to the 50-volt

point on the divider. The cathode minimum potentials on the 6A8 and 6K7 should be 3 volts negative. The 6F6 should receive a plate potential of 337 volts (plate to ground), and a cathode potential of 22 volts negative. All these tests can be carried out with the aid of a 1000 ohm-per-volt volt-meter.

To align the receiver, first tune it to 3XY which, by adjustment of the oscillator trimmer, should be made to come in at about 12 on the dial. Adjustment of the aerial trimmer should now be made until maximum signal strength is obtained. (Note that these adjustments should be carried out with the volume control retarded as much as possible, so that small changes in intensity can be more easily noticed.)

When the peak setting has been obtained at the high frequency end of the dial, tune the set up to the low frequency end, and endeavor to bring in 2FC, 7ZL, or 3AR if the first two cannot be received. Adjust the padding condenser (which previously should have been set back one full turn from the full-in position) until greatest signal strength is obtained, meanwhile rocking the tuning gang back and forth over a few degrees to get the peak setting.

When the receiver is made to operate properly it will be found to be capable of extremely fine results. No difficulty will be met with in separating the majority of the Australian stations, and certainly there will be no interference experienced between local and interstate broadcasters. At the time of writing no selectivity checks have been made on the receiver in our laboratory, but air tests indicate that the set has it to a very high degree.

Notwithstanding this, the tone quality of the receiver is all that could be desired, and as we mentioned earlier, its sensitivity is much higher than that ordinarily obtained with receivers of similar type.

This photograph of the receiver shows that the completed assembly is both neat and compact.

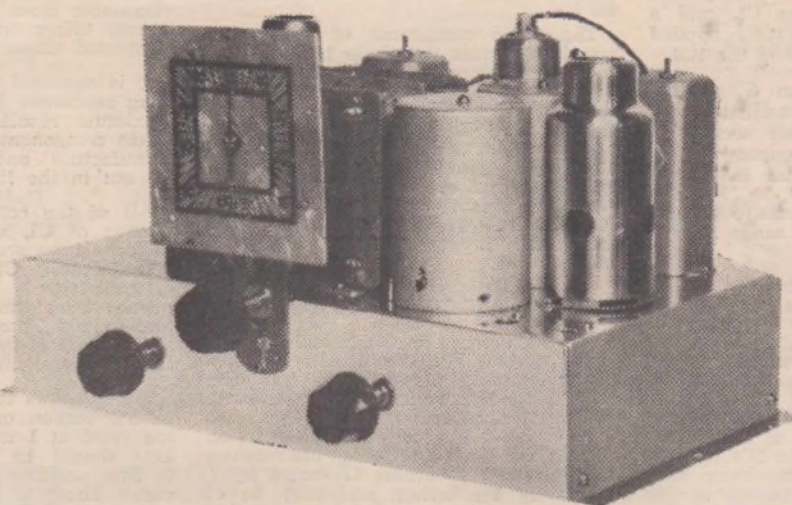

The three controls on the front of the chassis are: Centre, the main tuning control; left, the battery switch; and right, the volume control.

The Beginner's Battery Super-Het.

A simple and economical four valve battery super-heterodyne which can be built by the novice, with the certainty of obtaining excellent results. The sensitivity and tone of the receiver are particularly pleasing.

By H. R. SETFORD

MANY country listeners are still using out-of-date radio receivers built from five to seven years ago. If anyone dares suggest they obtain a more modern receiver they raise their hands in horror. "Think of the cost," they will say, "and, besides, the old set still gives excellent results."

This may be so, but these old type battery-receivers of five and six valves simply eat up battery power. Besides consuming anything from 15 to 25 milliamperes from the "B" battery, the "A" current drain is enormous. In some cases this may reach two amperes.

THE receiver to be described is a four-valve battery-operated super-heterodyne designed to give maximum results, with economy of battery consumption and a minimum of components. How well this specification has been carried out is evidenced by the completed receiver. An idea of the very

A modern four-valve battery-superheterodyne receiver will give vastly superior results from the viewpoint of economy, tone, and sensitivity, to five and six valve battery sets of earlier vintage. A modern receiver of this type may be built for the price of three sets of batteries, and the cost of the frequent recharging of the "A" battery for the older receiver.

As a set of batteries will last from seven to twelve months on a modern receiver, it is obvious that the saving in upkeep costs will pay for the new receiver in a very short time.

few parts needed for the construction of the set may be gauged by the under-chassis view of the completed assembly, whilst a brief statement of the battery consumption will convince the sceptic of the undoubted economy of this modern receiver.

The batteries required for the receiver

are a single two volt accumulator as an "A" battery, 90 volts of "B" battery, and a 4.5 volt "C" battery. The current drain from the "B" battery is 9 milliamperes, whilst that from the "A" battery is .54 of an ampere. This means that a 60 ampere-hour accumulator would supply the receiver for a little over one hundred hours, whilst a set of heavy duty "B" batteries should last for from seven to 12 months. The "C" battery will last indefinitely, as there is no current drain from this battery.

The receiver is exceptionally simple to build, and anyone who can handle a screwdriver, a pair of pliers, and a soldering iron will have no difficulty in constructing it from the directions given.

Circuit Details

A glance at the schematic circuit diagram shows that the receiver is quite conventional apart from the fact that many subsidiary components have been eliminated. This does not mean that these parts have been left out just to simplify or cut the cost of the finished receiver. Exhaustive tests were carried out to find just what components could be eliminated without affecting the results or sensitivity in any way. A 1C6 pentagrid converter is used as a combined first detector and oscillator valve. The modulator grid section of this valve is tuned to the frequency of the incoming signal by the section G1 of the gang condenser and the coil L2.

It will be noticed that the earth end of this coil is not connected directly to

earth in the usual way, but is by-passed to earth by the condenser C1, and a negative potential of 1.5 volts applied through the coil to the grid of the 1C6.

By means of the section G2 of the gang condenser and the oscillator coil secondary, L3, the oscillator section of the 1C6 is tuned to a frequency of 460 k.c. higher than the signal being received. The padder, PD, is inserted in this tuned circuit to ensure perfect tracking over the tuning range of the receiver.

The resultant mix between the station and the local oscillator is a signal of 460 k.c. appearing in the plate circuit of the pentode section of the 1C6. This signal is fed to the primary winding of the intermediate frequency transformer IFT1, the primary and secondary of which are tuned to a frequency of 460 k.c. The secondary of this transformer feeds the grid of the 1C4 operating as an intermediate frequency amplifier valve. The signal energy is fed from the plate of this valve to the rectification diode of the 1B5 via the second intermediate frequency trans-

former, IFT2, which is also tuned to 460 k.c.

The audio component of this signal appearing across the diode load resistor, which, in this case, is the volume control, VC, is fed to the triode amplifier section of the 1B5 through the condenser, C4. This valve is resistance-coupled to the grid of the output valve, a type 1D4 pentode, and the signal energy appears on the grid of this valve via the resistor-capacity combination, R3, C5, R4. The plate of this valve feeds the input transformer of the speaker, DS.

Components Reviewed

So much for the theoretical side of the receiver. For the benefit of those about to build the receiver, but who have had no previous experience of set construction, a description of the parts necessary for its construction will be given. The chassis on which the receiver is to be built measures 12 inches by 7 inches by 2½ inches, and may be of steel, aluminium, or other suitable metal. Of these materials aluminium is probably the most suitable. It is easier

worked than the others and is readily obtainable from the majority of radio houses either in sheet form or as a completed chassis.

It is essential that the coils and the gang condenser be carefully matched if maximum results are to be expected. These components should be of reliable manufacture and to the specification set out in the list of parts.

All of the condensers, with the exception of C1, should be of the mica dielectric type and should be of reliable manufacture. C1 may be of the paper dielectric type. The intermediate frequency transformers, IFT1, IFT2, are 460 k.c. units. Those used in the original receiver are of the Ferrocart type, manufactured by Eclipse Radio Pty. Ltd.

The resistors for the receiver may be of the carbon or metallised type. All are rated at 1 watt capacity. The sockets should be selected with a view to firm positive contact with the valve pins. Those of the wafer type are recommended. Three of the sockets must be equipped with shield cans. The battery switch must have a clean posi-

THE COMPONENT LIST AND SCHEMATIC CIRCUIT DIAGRAM of The Beginner's Battery Super-Het.

Chassis, measuring 12 inches by 7 inches by 2½ inches.

Coil Kit, consisting of aerial and oscillator coils for 465 k.c. Oscillator coil to suit 1C6.

- C1, .1 mfd. tubular condenser.
- C2, .0001 mfd. mica condenser.
- C3, .0002 mfd. mica condensers.
- C4, C5, 02 mfd. mica condensers.
- C6, .004 mfd. condenser.

(All I.R.C.)

G1, G2, two-gang condenser to suit coils.

IFT1, IFT2, 465 k.c. intermediate frequency transformers.

PD, 465 k.c. padded condenser.

R1, 50,000 ohm resistor. (T.C.C.)

R2, 1 megohm resistor. (T.C.C.)

R3, 100,000 ohm resistor. (T.C.C.)

R4, 500,000 ohm resistor. (T.C.C.)

Sockets, 1-7 pin, 2-6 pin, 1-5 pin and 1-4 pin.

SW, S.P.S.T. battery switch.

VC, 500,000 ohm volume control potentiometer.

Sundries: Wiring flex, nuts and bolts, 4 terminals, 2 grid clips, small quantity of tinned copper wire, 7-pin battery plug, dial to suit gang condenser, 3 knobs, 1 yard of braided wire, and 3 valve cans.

Batteries: 2-45 volt heavy duty batteries, 1-4.5 volt "C" battery, and a two-volt accumulator.

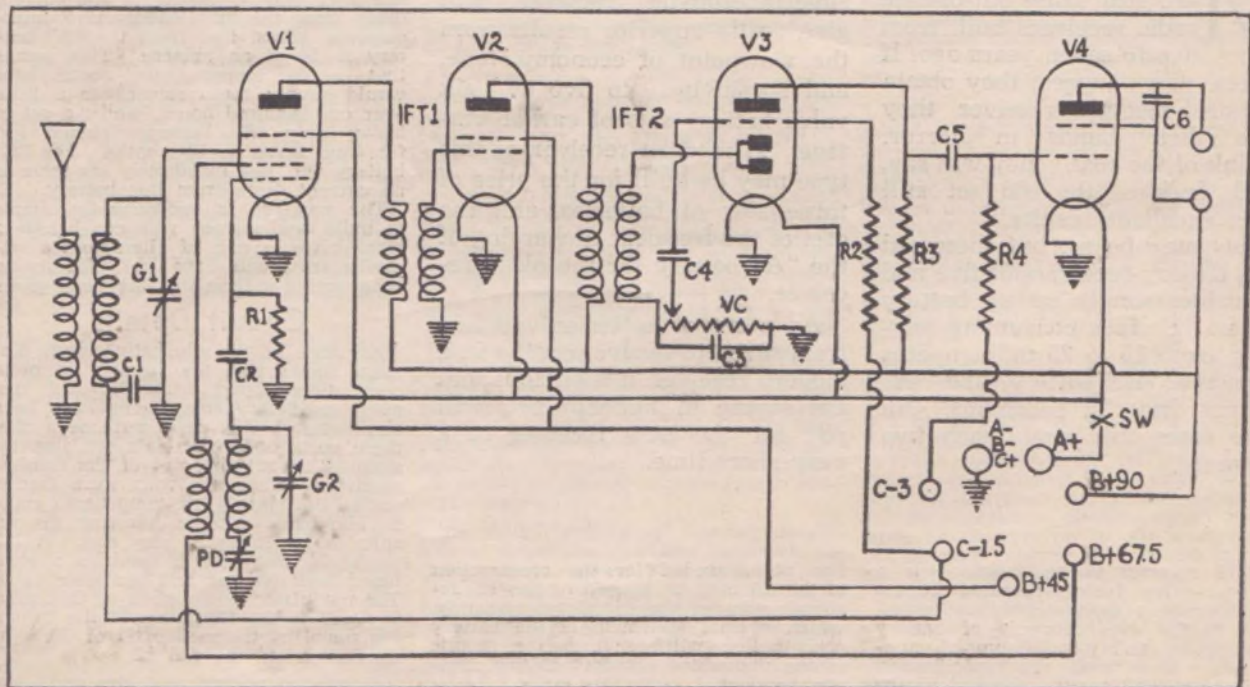



Lowest Prices
in
Victoria
on all
New and Used
**RADIO
SETS and
PARTS**

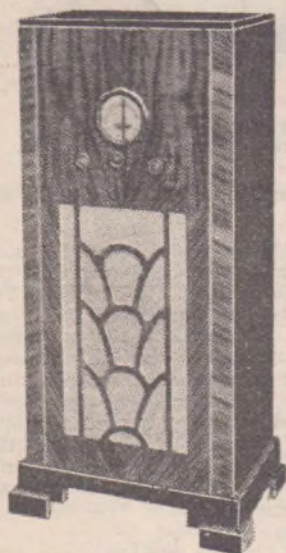

**BATTERY
SETS**

Latest Type
Consoles

Built in Rola Speaker,
2-v. 100-Amp. Accum.
H.D. B Batteries, brand
new. Guar. 12 months.

From . . .
£7/10/-
Terms Arranged

**All-Electric
SETS**

We Stock
Radiolas
Essanays
Airzones
Croydens

Prices from
£9/19/6
NO DEPOSIT
From 3/- Weekly

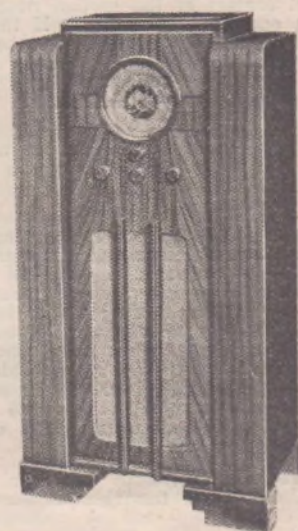

Kit of Parts or
Complete Chassis
for any Circuit in
this book supplied
on request.

Let us quote you

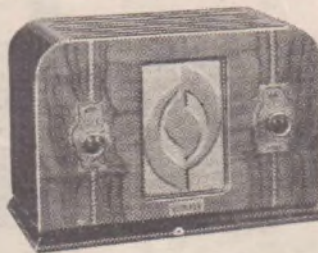

**"Marvelle"
Midget Sets**

AC, DC, or Universal
Latest Type 6 Pin Valves
Rola or Jensen Dyn. Sp.
Receives all Stations.

New and
Guar. **£6/6/-**
12 Months

Valve Reductions
Licensed RCA Patents

	List Price	Our Price
30's	16/-	11/3
32's	16/6	11/9
33's	17/6	12/3
47's	16/6	11/9
57's	16/-	11/3
58's	16/-	11/3
2A5's	16/6	11/9
80's	13/-	9/6

All Boxed and New.

B Batteries
Guar. 1st Quality

	List Price	Our Price
45 V. L.D.	8/9	6/9
45 V. H.D.	14/6	11/-
60 V. L.D.	11/6	8/8
60 V. H.D.	18/-	14/6
45 V. T.D.	18/-	14/6

The Longer Life Battery
at a Lower Price

**Chassis
Blanks**

18G. Alum. 2½in. Deep
11 x 7¾, 3/6 15 x 8¾, 4/9
12 x 7¾, 3/9 16 x 8¾, 5/3
Valve Holes cut, 3d. ea.
Trans. Holes cut, 6d. ea.

Speakers

Complete Range of
ROLA, JENSEN
SAXON, DYNAMIC
PERMAGNETIC
HIGH-FIDELITY
Prices on request.

Send your enquiry to us, a 2d. Stamp will save you Pounds.
Our Spacious Used Dept. can supply Quality Parts with a New Part Guarantee.

NOTE THE NAME
AND ADDRESS

MARCO'S RADIO Pty. Ltd.

Phone M1993

232 SWANSTON STREET, CITY (1 Door from Lit. Bourke St.)

tive action and may be of the toggle or shaft operated type, depending on whether the completed receiver is to be installed in a cabinet or not.

The volume control potentiometer has a resistance of 500,000 ohms and should be of a type which has the shaft insulated from the working parts of the resistor.

The loud speaker for this receiver should be of the per-magnetic type with a transformer of 14,000 ohms matching impedance.

Mounting the Parts

The positions of the various components may be observed from the numerous photographs of the receiver, and these should be studied while this part of the construction is being carried out. Before mounting the gang condenser in its central position on top of the chassis a lead must be soldered to the underneath contact of the section nearer the front edge of the chassis. If the condenser is fitted with wipers on the moving plates a piece of the tinned copper wire should be soldered to these wipers and passed through the chassis.

The lead soldered to the fixed side of the condensers should be of covered wire and must be passed through a hole drilled in the chassis.

The coils may now be mounted in position on the right of the gang condenser, the oscillator coil being the one toward the front of the chassis. Two leads should be brought out through the top of the can housing the aerial coil. One of these connects to the fixed plate contact of the rear section of the gang condenser, while the other solders to one of the grid clips which will connect to the grid terminal of the 1C6 valve, when it is placed in its socket on the right edge of the assembly.

IFT1 is mounted in the rear right-hand corner of the chassis, the other

components mounted along the back of the chassis are proceeding from right to left the 1C4 socket, IFT2, and the 1B5 socket. The socket for the 1D4 pentode is situated on the left of the assembly.

The volume control, VC, and the switch, SW, are mounted on the front of the chassis, while along the back of the chassis are mounted the aerial and earth terminals, the battery inlet socket and the two loud speaker terminals. The aerial terminal and the two speaker terminals must be insulated from the chassis by means of washers. If any one of these terminals comes into contact

with the metal of the chassis the receiver will not operate.

The padder condenser may be seen mounted in the left-hand corner of the chassis adjacent to the 1C6 socket. The only other component which is bolted directly to the chassis is the condenser, C5. It may be held by the mounting bolt of the 1D4 socket. When mounting the sockets in position solder lugs should be attached to their mounting bolts, which are nearest the centre of the chassis. When all of these components have been mounted in their correct positions, the wiring may be commenced.

Wiring Details

A start may be made by soldering in position the tinned wire which will act as the earth return for the wiring. This is done by connecting together, with tinned wire, the solder lugs which were placed in position under the holding bolts for the sockets and joining the same wire to the earth terminal.

The tinned wire lead connected to the wipers on the gang condenser must be soldered to this wire also. In order to simplify the wiring to the sockets a standard numbering system will be used.

With the socket mounted in position on the chassis and with the two large holes of the socket away from you, the large contact on the right will be No. 1, the next contact to the right, i.e., moving in a clockwise direction, will be No. 2, and so on, until the various contacts on each socket have been numbered.

This numbering is carried out from the under chassis view of the socket contacts.

The number one contacts of each of the four valve sockets should now be connected together and joined to one of the contacts on SW. The number one contact of the battery socket connects to the remaining switch contact. The number 6 contact of V1; number 4 of V2; number 6 of V3; and number 5 of V4; solder directly to the earthed wire previously soldered in position.

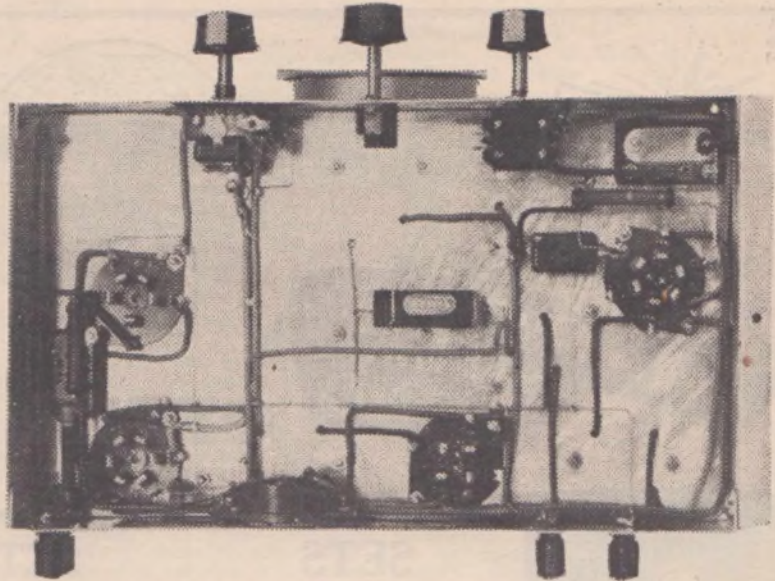

This photograph of the receiver shows the layout and wiring beneath the chassis. Note the very few components necessary for the construction of the receiver.

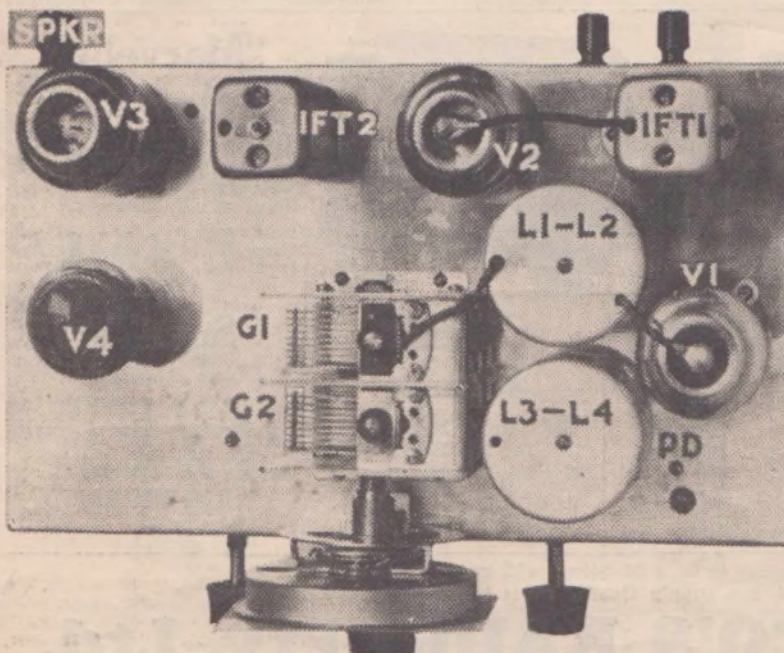

This photograph of the receiver shows the layout of the parts on top of the chassis. It is key-lettered to agree with the written description.

To this wire are connected the number 7 contact of the battery socket and one of the outside contacts of the volume control VC.

The coils should now be wired into circuit. Join the aerial lead of L1 to the aerial terminal and the earth lead of this same coil to earth. The earth contact of L2 connects to one side of the condenser, C1, and to the number 5 contact of the battery socket. The remaining side of C1 joins to earth. The two leads from the grid contact of L2 are taken through the top of the shield can, one to the fixed plates of the rear section of the gang condenser and the other to the grid clip of the 1C6. Solder one contact of the condenser C2, to the number 4 contact of the socket, V1.

To the remaining contact on C2 is connected the lead from the fixed plates of the front section of the gang condenser, and the lead from the grid contact of the coil L3. The earth contact of this coil connects to the fixed plates of the padder condenser, PD, the moving plates of which are earthed. The plate contact of the oscillator plate feedback coil, L4, connects to the number 3 contact of the socket V1. The "B" positive lead of this coil connects to the number 3 contact of the battery socket.

Resistor R1 may now be soldered in position between the number 4 contact of V1 and earth. The plate lead of IFT1 solders to the number 2 contact of V1, while terminal No. 5 of this socket connects to the No. 3 contact on V2. The "B" positive lead from IFT1 connects to the No. 2 contact of the battery socket, as does the corresponding lead of IFT2.

The earth lead of IFT1 joins to earth while the grid lead of this component is taken through the hole provided in the top of the can to the grid clip of V2. The plate lead of IFT2 connects to the No. 2 contact of socket V2. The grid lead from IFT2 joins to contacts 3 and 4 of socket V3, while the earth lead from IFT2 connects to the remaining outside contact of the volume control, VC. This lead must be wired with the braided wire.

When using this wire the metal braid should be cut back with a knife for

about an inch from the point where it solders to the component to which it is to be connected, bound with fine wire, and soldered. The inside flex may then be connected to its correct position and the metal braid earthed without fear of "shorts."

A similar braided lead connects the No. 5 contact of the socket V3 to one contact of the condenser C4, the other contact of which solders directly to the centre contact of VC.

Condenser C3 should be soldered in position between the outside contact of VC, which connects to IFT2, and the earth wire. Solder a lead to the No. 3 contact of V2 and connect it to the No. 4 contact of the battery socket. Resistor R2 may be soldered in position from the No. 5 contact of this socket and the No. 5 contact of V3.

Connect together the No. 4 contact of V4 and one of the speaker terminals and join them to the No. 2 contact of the battery socket. Resistor R3 connects from this same speaker terminal to one contact of C5 and to the No. 2 contact of V3.

Contact No. 2 of V4 joins to the remaining speaker terminal, whilst contact 3 of V4 is wired to the unconnected side of C5. The resistor, R4, connects between this same side of C5 and contact 6 of the battery socket.

Condenser C6 may now be soldered in position across the speaker terminals.

This completes the wiring of the receiver. It should be re-checked several times to make sure it is correct. When this has been done, and everything found to be in order, a battery cable should be made from different colored flexes and attached to the battery plug. A color code should be kept so that the leads to the different batteries may be seen at a glance.

Operation and Alignment

Before placing the valves in their sockets the batteries should be connected and the filament switch turned off. The speaker leads may then be connected and the pentode valve inserted in its socket. The switch may now be turned on; if the pentode valve lights

to normal brilliancy the remaining valves may be inserted and the aerial and earth wires connected to their respective terminals. If the pentode valve lights up brightly the switch must be immediately turned off and the wiring and battery hook-up examined for faults. The receiver should not be again turned on until the fault has been found and corrected.

If everything is in order the receiver may be turned on and a station, say 3XY, tuned in on the higher frequency end of the band. The trimmers on the gang condenser should now be adjusted.

The trimmer on the oscillator section of the gang condenser should be varied until this station is received at approximately 10 degrees on the dial. The trimmer on the G1 section of the gang should next be adjusted for maximum signal strength.

During these adjustments the volume control should be retarded, as each alteration to the trimmer brings about an increase in signal strength. At all times adjustments should be carried out on a weak signal. This is because it is very much easier to note small changes in the strength of signals when these signals are weak than if the adjustments are being performed on a very strong signal.

Now tune a station on the lower frequency part of the band, and adjust the padder condenser for best results. While this is being done it will be necessary to re-tune the receiver slightly as the padder setting is altered. If, as before, this operation is carried out on a weak signal, there will be no difficulty in determining the correct setting.

When these adjustments have been carried out, the receiver should be in a fairly sensitive condition, but, in almost every case, an improvement can be brought about by careful adjustment of the trimmers on the intermediate frequency transformers, IFT1 and IFT2. This should be done with the receiver tuned to a station near the centre of the band. As before, the adjustments must be carried out on a weak signal. Take particular note of the position of the trimmer settings on each transformer, so that if necessary these settings may be duplicated. The trimmers on IFT2 should be tuned to give greatest signal strength, and the grid trimmer of IFT1 adjusted likewise. On no account must the trimmer on the plate of the 1C6 be adjusted once the receiver has been padded.

Again we would urge those builders of super-heterodyne type of receivers to have them aligned on a signal generator if possible. Although excellent results may be obtained when this type of receiver is aligned by ear, maximum results can only be obtained when such sets are aligned on an oscillator or signal generator.

The results obtainable from this receiver are astounding. Tested in the suburban area on an efficient aerial and earth system, no difficulty was experienced in tuning the majority of interstate stations at excellent strength.

The receiver can be thoroughly recommended to those in search of an economical and simple set, capable of providing real entertainment and yet so easy to build that even those who have never before tackled set construction can attempt with certainty of success.

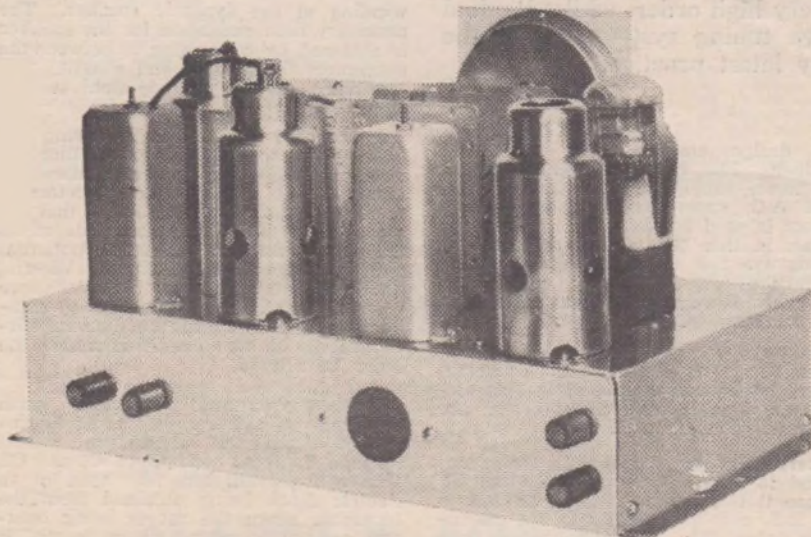

Another photograph of the receiver, showing the position of the aerial and earth terminals, the battery socket and the speaker terminals.

The Universal Dual- Wave "7"

Capable of operation in either direct or alternating current areas, and possessing a tuning range embracing short as well as broadcast wavelengths, this dual-wave receiver should appeal particularly to the countryman who resides in D.C. electric supply areas.

By P. R. DUNSTONE

IN the last few months considerable space has been devoted to the description of both battery and A.C. operated all-wave receivers, but not one of the many circuits which have been published has catered for those who live in direct current areas.

Realising this, we have designed a dual-wave receiver which embodies the latest Universal valves and a number of interesting technical features. With this set, people located in D.C. areas have

ALTHOUGH the receiver employs six valves and a barretter, the assembly and the wiring of the parts is not difficult. Provided the builder adheres to the directions given in the following paragraphs no trouble should be experienced in placing the set into operation.

A special dual-wave tuning box has been used to permit the receiver to tune from 18.5 to 50 metres and from 195 to 550 metres with two sets of coils. This feature adds to the ease of construction since the tuning condensers, coils and switching assembly are already wired.

Before commencing the constructional description of this receiver let us take a brief run over the circuit design and discuss the salient points of the set. The circuit of this six-valve super-heterodyne is basically that of any ordinary

the opportunity of obtaining an efficient dual-wave receiver and thus of entering into what is probably one of the most fascinating sides of radio—"D.X. reception."

The set possesses distinct advantages over one of the standard A.C. operated type inasmuch as it can be operated on either alternating or direct current mains. Its sensitivity and tonal quality is of a very high order, whilst its dual wave tuning system follows the very latest practice.

A.C. design, employing six tubes and rectifier. The chief difference lies in the power supply. Where, in the standard A.C. super-het, a power transformer is used between the rectifier and mains, in this "Universal" receiver the mains are fed direct to the rectifier, while the correct filament voltage for the tubes is regulated with the aid of the barretter lamp.

Although modern technical improvements, such as A.V.C. and universal valves have been employed in this circuit, the fundamentals of its design are perfectly conventional.

Starting at the aerial coil, the signal is fed to the radio frequency tube, V1, where it is amplified and passed on to the R.F. coil and finally to the modulator valve, V2. This tube, which is a frequency converter type, provides the desired mixing of the incoming signal

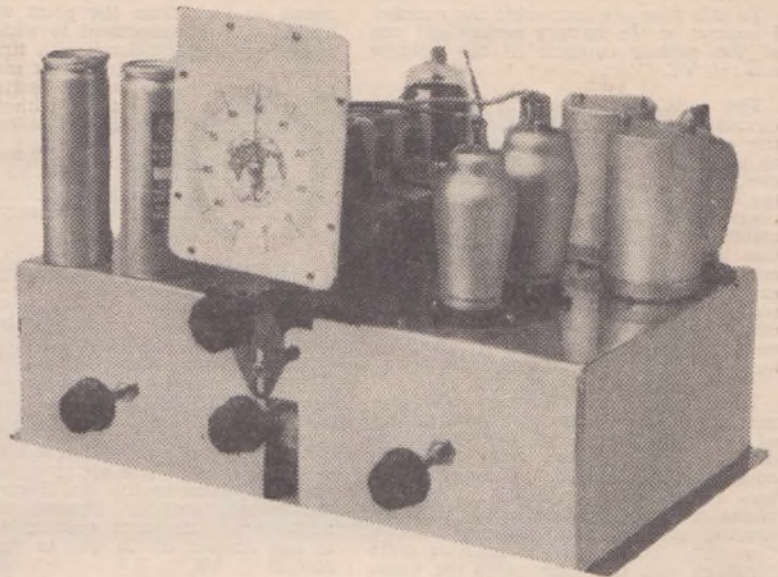

The front view of this sensitive receiver shows that it employs four controls, including the wave change switch.

and the locally generated signal. The resultant signal, which is at a frequency of 465 k.c., is then fed to the first intermediate frequency transformer and amplified by the IF valve, V3.

Continuing, the signal is passed through the second intermediate transformer to a valve which is the latest development in the universal series. This tube is a duo-diode-triode combining two diodes, one for rectification and the other for A.V.C. use, and a triode section which functions as a driver valve for the pentode output tube. In this tube the signal is rectified to audible frequencies and finally passed through the triode portion and the resistance coupling unit, R13, C14, and R14, to the grid of the pentode valve, V5, whence it is amplified and fed to the dynamic speaker.

Since it is necessary to make use of all available voltage, a low D.C. resistance filter choke is used in the power filtering circuit in preference to the standard method of using the field winding of the dynamic speaker. The necessary field excitation for the speaker is obtained by connecting it between the maximum "B" supply and chassis. The resistance of the speaker field is 7500 ohms.

A point of importance in wiring the filaments of the various valves into the circuit is the order in which they are arranged. It will be seen on referring to the schematic circuit diagram that the second detector, V4, has one side of its filament connected at earth potential and is followed by V2, V1, V3, V6, and finally V5, at the highest potential above ground. This order of wiring is to eliminate hum pick-up in the filament circuit, and on no condition must the order be altered.

Both the external aerial and earth terminals on this receiver must be insulated from the aluminium chassis through the fixed condensers, C1 and C2. This will prevent any likelihood of an electric shock being obtained from the terminals when the set is being operated on supply means where "earth" is common to one side of the power supply.

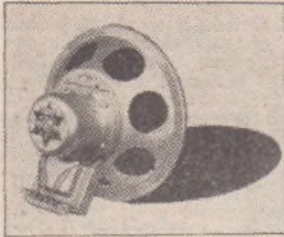

"01 STAR"

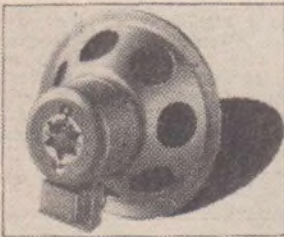

"05 STAR"

STAR AMPLION SERIES

"01 STAR"

The "01 Star" Permanent Magnet Dynamic Speaker places a unique speaker in the hands of the public in Australia, if not throughout the world. Incredible as it may seem, Amplion has now produced a Permanent Magnet Dynamic Speaker which, whilst being the same weight and dimensions as its prototype 8in. Electro-Magnet, withal has the same efficiency. In spite of its compactness, it is more powerful than any 8in. Permanent Magnet Dynamic Speaker released to date.
PRICE £2/17/6

"05 STAR"

The "05 Star" is another departure in the Permanent Magnet field, this speaker lining up with the popular Model "R" Amplion Electro Magnet type. It is also a replica, in external appearance, of the "R" model. The performance fully equals that of the famous "R" type, which is accepted as the most efficient all-round speaker on the Australian market. Leading manufacturers of brand line receivers are already standardising on this splendid speaker for their high grade Battery Operated Receivers.
PRICE £3/15/-

"L5 STAR"

The "L5 Star" has the same cone dimension as the Model "R" 10in., but is also of the Permanent Magnet type and employs the most powerful type of Permanent Magnet yet released in Australia. At long last a highly efficient speaker is now available for portable amplifiers, talkies, etc., but withal not calling for any power leads for excitation. Also ideally suited for De Luxe Battery Operated Receivers.
PRICE £5/10/-

ALSO AVAILABLE

ELECTRO MAGNET TYPES

Model.	Remarks.	Size of Cone.	Price.
M	Standard winding	5in.	£1 5 0
Q	Standard winding	8in.	£1 15 0
R	Standard winding	10in.	£2 15 0

WRITE FOR PUBLICATION GIVING DETAILS OF FULL RANGE

Advt. of **AMPLION (A'SIA) LTD.**, 66 Clarence Street, SYDNEY.

RADIO MAGAZINES AND BOOKS

RADIO AND SOUND PROJECTION MAGAZINES

	Mthly.	Postge.	Yrly.
Broadcasting and Broadcast Advertising (U.S.A.) (24 issues yearly)	2/	4d	25/
Communication and Broadcast Engineering (U.S.A.)	2/	3d	21/
Wireless and Television Review (English)	1/6	3d	19/6
Television (English)	1/6	3d	19/6
Radio News (American)	1/3	3d	18/
Radio Craft (American)	2/	3d	21/
Q.S.T. (American)	2/	2d	19/6
Proceedings of the Inst. of Radio Engineers (American)	7/6	3d	65/
Radio Engineering (American)	2/	2d	21/
Radio (U.S.A.)	2/	2d	21/6
Electronics (American)	3/6	3d	32/
Short Wave Craft (American)	2/	2d	21/
Radio World (American)	2/	3d	21/
"Service" (Rider) (American)	2/	3d	21/
International Projectionist (American)	2/	3d	21/
Radio Retwiling (American)	2/6	3d	21/
Wireless Magazine (English)	1/6	4d	21/
Gramophone (English)	1/9	3d	21/
Experimental Wireless and Radio Engineer (English)	3/6	3d	39/6
	Weekly.	Postge.	
Wireless World (English)	6d	2d	29/6
Listener-In (Aust.)	3d	1d	
Wireless Weekly (Aust.)	3d	1d	
Radio Programme (Aust.)	3d	1d	
	Mthly.	Postge.	
Amateur Radio (Aust.)	6d	1d	
Radio Review of Australia	1/	1d	

BOOKS OF AN ADVANCED NATURE FOR ENGINEERS, STUDENTS AND EXPERIMENTERS

Radio Amateurs' Handbook, by Q.S.T.—American Radio Relay League. This is unquestionably the premier radio text-book printed Revised yearly, modern as today, splendidly printed, profusely illustrated, accurate and informative. Twice as large, same price. Now in its 13th edition (1936). Every "Ham" and fan swears by it. 7/6 each; postage 1/.

Handbook by "Radio" (California), 1936, for Microphone, antenna, ultra H.F. and all Radiotelephony data 7/6 plus 1/ postage Worth double.

P.M.G. Handbook of Regulations for Wireless Telegraphy Just published, following the Madrid Conference. All the new Q Signals. 1/6 and 2d postage.

The above three books are the foundations of the course for A.O.P. Licence, and are prescribed by the Wireless Institute of Australia as essential.

	Price	Postage
Radio Servicing Course. Ghirardi & Freed	27/6	1/3
Admiralty Handbook of Wireless Telegraphy. This Marvellous book of over 1000 pages is astounding value at	12/6	1/3
AUTOMOBILE RADIO		
Official Auto-Radio Manual	17/8	6d
Specialised Auto-Radio Manual. Rider	27/6	1/
Auto Radio and Service	4/6	3d
1935 RADIO CRAFT LIBRARY		
The very latest from America in compact form:—		
No. 1. Radio Set Analysers.		
2. Modern Vacuum Tubes.		
3. Superheterodyne Book.		
4. Modern Radio Book-ups.		
5. How to Become a Radio Service Man.		
6. Bringing Electric Sets up to Date.		
7. Radio Kinks and Wrinkles.		
8. Radio Questions and Answers.		
9. Automobile Radio and Servicing.		
10. Home Recording and All About It.		
11. Point to Point Resistance Measurements.		
12. Public Address Systems. Amplifiers, Microphones.		
13. Air Conditioning.		
Each book complete, 3/6 per copy; postage 3d. £2/5/ the set.		

BOOKS — GENERAL

Radio Data Book	3/6	3d
Finding Foreign Stations	5/	6d
Radio Upkeep and Repairs for Amateurs	8/6	4d
Wireless: The Modern Magic Carpet	5/	6d
Servicing Superhets. 1935 Rider	9/6	6d
Radio Receiver Measurements. Barnard	7/6	6d
Radio Servicing Simplified	5/	4d
Book of Practical Radio. Scott Taggart	8/6	8d
S/W and Public Address Manual	4/	3d
How to Make Money in Servicing	4/	3d
50 Tested Wireless Circuits	3/9	6d
Superhet Receivers 1935 Witt	5/3	6d
Australian and New Zealand Call Book, 4000 Calls, Signs and Time Chart of the World	2/	3d
Everyman's Wireless Bolt	8/6	6d
Outline of Wireless R. Stranger	12/6	8d
Radio Telephony for Amateurs Ballantyne	9/8	8d
Citizens' Radio Call Book. Amateur Commercial and Short Stations of the World Over 80 Countries logged here. 1936	9/6	1/
Moving Coil Loud Speakers. Wireless World	2/6	4d
Morse Code Perry	1/	2d

Send stamped addressed envelope for our free Catalogue of 1000 books and magazines on Flying Radio. Acoustics, Sound Projection, Television, Refrigeration, Air Conditioning.

McGILL'S AGENCY

183-185 ELIZABETH ST., MELB.
 The G.P.O. is opposite. C 8113

Valve Details

The valves used in the receiver are two CF2's, one CK1, one CBC1, one CL2, one CY2, and one C1. These valves are included in the Philips new 200 m.a. AC/DC series and are specially designed for use in universal receivers.

The CF2 is a variable mu radio frequency valve suitable for use in receivers incorporating automatic volume control, particularly when associated with the CK1 octode frequency changer.

When the CF2 is employed as an IF or RF amplifier, the usual precautions must be taken to ensure stability. Capacitive and inductive coupling between the control grid and plate circuits should be minimised. All components in the various stages should be magnetically and electrostatically separated, and the control grid leads kept as short as possible. In some cases it may be neces-

sary to de-couple the plate or screen returns by means of a condenser of at least 1 mfd capacity. The necessary characteristic data for this valve is as follows:—

The CF2 Variable Mu R.F. Pentode

Heater voltage	13.0 V.
Heater current2 A.
Plate voltage	250 V.
Screen voltage	100 V.
Plate current	4.5 m.a.
Screen current	1.5 m.a.
Amplification factor	2200

The rated maximum screen voltage for the CF2 is 125 volts. When this valve is biased to a low value of mutual conductance and the late current decreases below 1 m.a., the screen voltage may be allowed to approach 150 V. Thus by judiciously selecting the voltage divider or series resistance for the screen

feed, it is possible to give the valve an even cut-off if necessary.

The CK1 Octode is an electron coupled frequency changer designed for use in receivers incorporating the Philips 200 m.a. AC/DC series of valves. The Octode is a recent development in valve design, and represents an improvement on the existing types of pentagrid converters, i.e., electron-coupled frequency converters. The octode is similar in principle to the 2A7 with the addition of a sixth (suppressor) grid. Thus the first detector or mixer portion of the octode is a pentode, whereas the counterpart of the 2A7 is a tetrode.

The octode combines all the advantages of the electron coupled frequency converter with a low signal to noise ratio, a high conversion amplification and minimum frequency shift in the oscillator circuit when the control grid is negatively biased for volume control purposes. The characteristics of this tube are:—

THE COMPONENT LIST AND SCHEMATIC CIRCUIT DIAGRAM of The Universal Dual-Wave 7

- 1 Radiokes dual wave coil box. Type DWA3.
- C1, C12, .00025 mfd. mica condensers.
- C3, C4, C6, C9, C8, C17, .1 mfd. condensers.
- C19, C7, .5 mfd. condensers.
- C5, C10, .0001 mfd. mica condensers.
- C14, C11, C16, C2, .02 mfd. condensers.
- C13, C15, 25 mfd. low voltage test electrolytic condensers.
- C18, .01 mfd. condenser. (All T.C.C.)
- CH, 30 henry low resistance power choke.
- DS, Dynamic speaker, 7500 field to suit CL2. (Amplion Rola.)

- E1, E2, 8 mfd. 500 volt test electrolytics.
- IF1, IF2, 465 k.c. intermediate frequency transformers.
- MP, polarised power plug.
- R1, R9, 650 ohms 25 m.a. resistors.
- R2, 20,000 ohm resistor.
- R3, R4, R7, 100,000 ohm resistors.
- R5, 50,000 ohm resistor.
- R6, 350 ohm 25 m.a. resistor.
- R16, 30,000 ohm resistor.
- R8, R10, R12, 1 megohm resistors.
- R11, 1000 ohm resistor.
- R13, 65,000 ohm resistor.

- R14, 500,000 ohm resistor.
- R15, 400 ohm 50 m.a. resistor.
- TC, 10,000 ohm tone control potentiometer. (All I.R.C.)
- Valves, 2—CF2s, 1—CK2, 1—CBC1, 1—CL2, 1—CY2, 1—C1, with sockets to suit. (Philips or Mullard replicas.)
- VC, 500,000 ohm volume control potentiometer.
- Sundries, Wiring flex, nuts and bolts, aerial and earth terminals, power flex, dial, knobs, grid clips, 2yds. of braided wire, and 5 pin speaker socket.

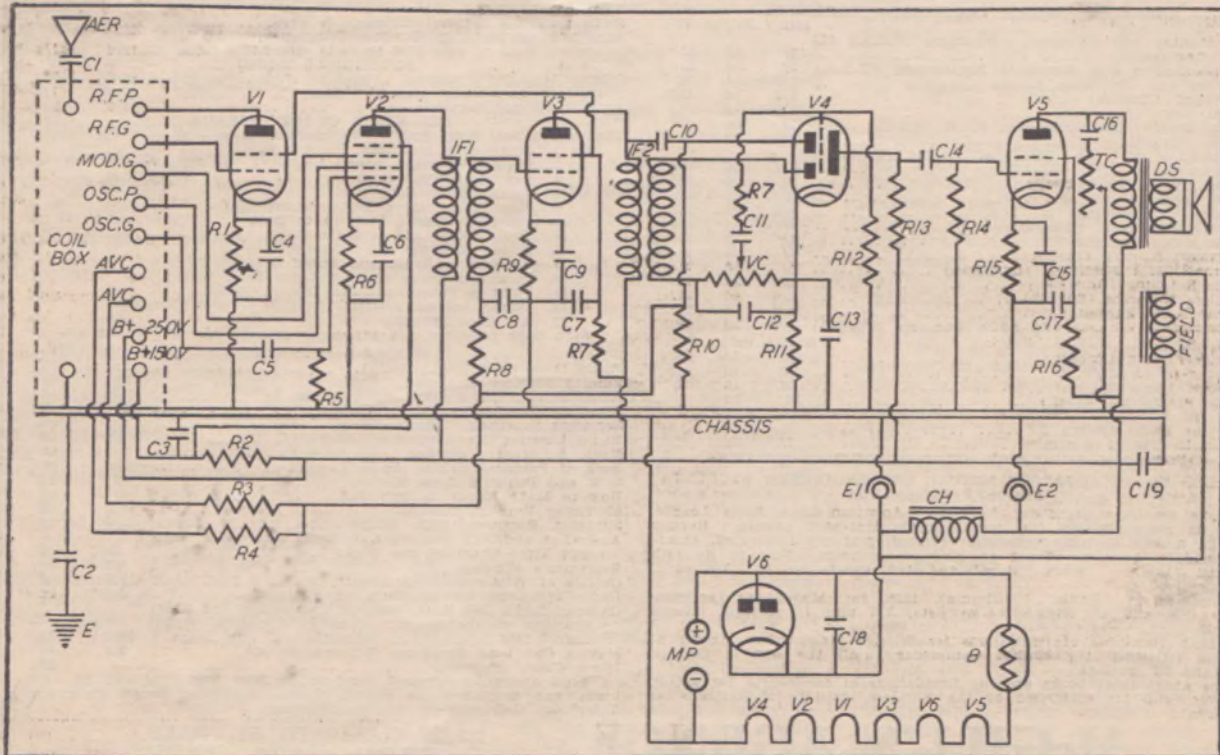

The CK1 Frequency Converter

Heater voltage	225
Heater current	6.0 m.a.
Plate voltage	3.0 m.a.
Screen voltage	0.8 m.a.
Oscillator plate voltage	1.5 V.
Negative grid bias	70 V.
Plate current	70 V.
Screen current	250 V.
Cathode current	2 A.
Conversion amplification	13 V.

The octode is not critical in respect to coil design, and will usually operate reasonably well with coils designed for the 2A7 and other similar valve types.

The CBC1, the latest addition to the Universal series of valves, is a double-diode-triode, and is admirably suited for a second detector and audio driver work.

The diode portion of the CBC1 may be used in the conventional manner for half or full wave detection. In the particular circuit under consideration, one diode plate is used as a half-wave second detector whilst the second diode plate is used to provide automatic volume control.

The triode section of the CBC1 is resistance coupled to the CL2 pentode in the output stage, and is used as a driver valve for the latter.

The CL2 power pentode tube is designed for use in conjunction with the 200 m.a. AC/DC series of valves and the barretter. It has been so constructed that even at a plate potential of 300 volts the output is adequate.

The CL2 Pentode

Heater voltage	24 V.
Heater current	2 A.
Plate voltage	200 V.
Screen voltage	100 V.
Plate current	40 m.a.
Negative grid bias	19 V.
Screen current	5 m.a.
Amplification factor	70
Watts output	3.55 W.

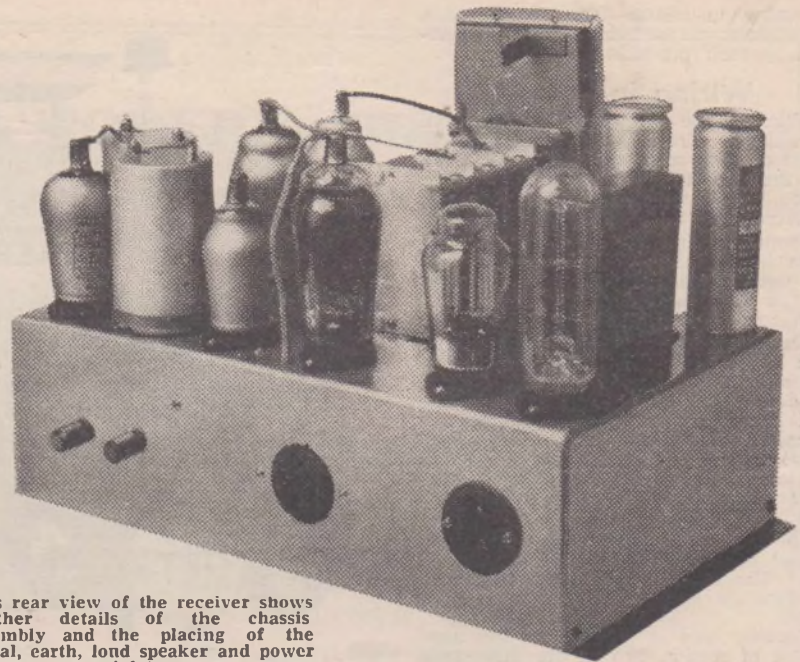

This rear view of the receiver shows further details of the chassis assembly and the placing of the aerial, earth, loud speaker and power inlets.

The CY2 is an indirectly heated rectifying valve which contains two separate rectifiers and series heaters.

The CY2 Rectifier

Maximum plate voltage	half-wave 250 V.
Maximum rectified output	120 m.a. (D.C.)
Maximum D.C. voltage between heater and cathode	250 V. (peak).

The receiver is built on an aluminium chassis measuring 13 inches by eight inches by four inches.

Looking down on top of the chassis, it will be seen that the three gang tuning

condenser and coil box assembly is mounted in the front centre of the chassis. It will be necessary in order to mount this box to cut from the chassis a hole of suitable dimensions to allow the three gang tuning condenser to be fastened level with the top of the chassis whilst the coils and switch gear inside the box will be mounted below the chassis level.

On the right hand side of the dual-wave coil box the radio frequency and converter valve sockets, V1 and V2, are mounted. These two sockets should be arranged so that their heater terminals are facing the sides of the chassis, thus allowing the shortest leads to be used when the wiring of the set is commenced.

Following V2 valve socket the intermediate frequency transformer, IF1, is placed in position, whilst at the back right-hand corner of the chassis is placed the intermediate frequency amplifying valve socket, V3. Continuing along the rear side of the chassis the order of the components is as follows: The second intermediate transformer, IF2; the second detector valve socket, V4; the pentode socket, V5; the rectifier socket, V6; and, finally, the barretter socket, B.

On the left-hand side of the chassis the two electrolytic condensers, E1 and E2, and the filter choke, Ch, are secured. This completes the mounting of all parts on the top of the chassis.

On the rear side of the chassis the aerial and earth terminals are mounted to the right-hand end, whilst the dynamic speaker input socket is arranged in the centre. A half-inch hole is drilled to the left of this socket and is used for holding a rubber grommet through which the power leads are carried.

On the front side of the chassis the volume control, VC, is secured on the right-hand side of the coil box, and the tone control, TC, is mounted on the left-hand side. Below the chassis it is not

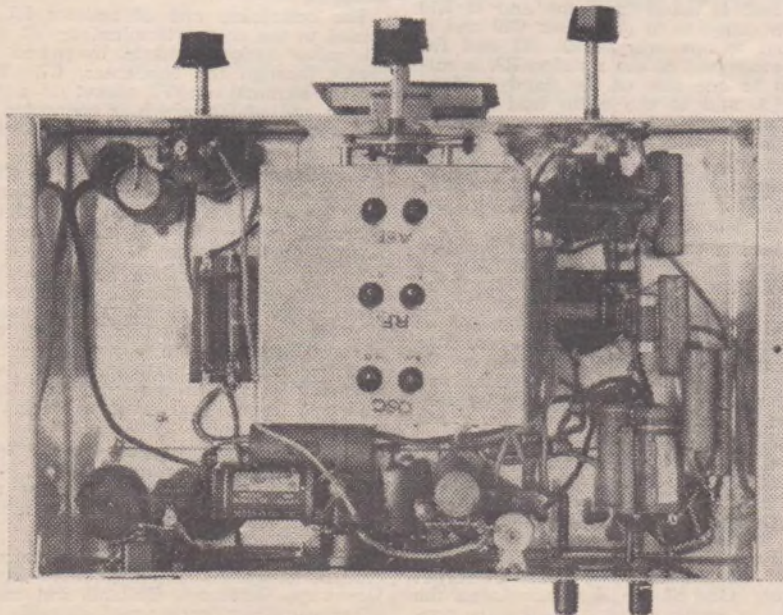

The under-chassis view shows that the components are wired into circuit around the coil box which occupies a central position in the chassis.

necessary to mount any components, since these will be held securely in position by their pig-tails.

Wiring in Words

Although the average set builder will be able to wire this receiver from the accompanying schematic circuit diagram, for the benefit of those who are unable to do so, we will give a word to word description of the wiring.

Commence the wiring by taking a lead from the aerial terminal to one side of the fixed condenser, C1. The other side of this condenser is wired to the aerial lead coming from the coil box.

The earth lead coming from the coil box is joined to the earth terminal on the side of the chassis through the fixed condenser, C2. The RF plate lead on the coil box is connected to the plate terminal on V1 valve socket, whilst a lead is taken from the fixed plates of the first section of the three-gang tuning condenser and connected to the grid pip on top of V1 valve.

The cathode terminal on V1 valve socket is secured to one end of R1 and C4. The other end of these two components are joined to the common earth wire.

Another lead is taken from the fixed plates of section two of the three-gang tuning condenser and is soldered to a grid clip which is connected to the grid pip on top of V2 valve.

The oscillator plate lead from the coil box is joined to the oscillator plate terminal on V2 valve socket. The oscillator grid lead from the coil box is soldered to one side of the fixed condenser, C5. The remaining side of the fixed condenser, C5, and one end of the resistor, R5, is connected to the oscillator grid terminal on V2 valve socket.

The other end of the resistor, R5, is taken to chassis.

The plate terminal on the VT valve socket is connected to the P lead on the intermediate frequency transformer, IF1. The G lead on IF1 is secured to the control grid on top of V3. The plate terminal on V3 valve socket is wired to the P lead on IF2 and to one side of the fixed condenser, C10. The other side of this condenser, C10, is soldered to one end of R10 and to diode 1 terminal on V4 valve socket. The grid lead on IF2 is taken to diode 2 on V4 valve socket.

The resistor, R9, and the condenser, C9, are connected to the cathode terminal on V3 socket. The other ends of these two components are taken to chassis.

The earth end of IF2 is joined to one of the outer terminals on VC and to one side of the fixed condenser, C12. The remaining outer terminal on VC and the other side of C12 are connected to the cathode terminal on V4 valve socket. The resistor, R11, and the condenser, C13, are also joined to the cathode terminal on V4. The other end of these two components are connected to chassis.

One side of the condenser, C11, is secured to the movable arm on VC, whilst the other side of this condenser is joined to the resistor, R17. The other side of R17 is taken to the control grid on top of V4 valve and to one side of the resistor, R12. The remaining end of R12 is joined to chassis.

The plate terminal on V4 valve socket is soldered to one end of the resistor, R13, and to one side of the fixed condenser, C14. The other side of con-

denser C14 is wired to one end of R14 and to the control grid terminal on V5 valve socket.

The other end of the resistor, R14, is connected to chassis. The resistor, R15, and the condenser, C15, are soldered to the cathode terminal on V5 valve socket, and the other end of these components are taken to chassis.

The plate terminal on V5 valve socket is joined to one side of the fixed condenser, C16, and to the P terminal on the dynamic speaker output socket. The other side of the condenser, C16, is connected to one end of the variable resistance, TC, whilst the movable arm on this resistance, TC, is joined to chassis.

A lead is taken from the end of R10 which connects to condenser C10 and is carried to one end of R8, R3 and R4. The other end of the resistor, R8, is soldered to one side of the fixed condenser, C8, and to the earth lead on IF1. The remaining side of C8 is taken to chassis.

The other end of resistors R3 and R4 are wired direct to the two leads marked A.V.C., which are brought out the side of the coil box.

A lead is connected from the negative terminal on the power socket, MP, to the filaments of the six valves in the order shown in the circuit diagram and through the barretter B to one side of the fixed condenser C18. This lead also goes to the two plate terminals on V6 socket and to the positive terminal on the power plug MP. The negative terminal on MP is taken to chassis.

The two cathode terminals on V6 are joined together and soldered to the vacant side of C18, to one end of CH, and to the positive terminal on the electrolytic condenser, E1. The other end of this choke, CH, is connected to the positive side of E2 and to the G terminal on the dynamic speaker output socket. One of the F terminals on the dynamic speaker output socket is connected to the chassis, whilst the other joins to the cathode of V6.

The screen terminal on V5 valve socket is connected to one side of C17 and R16. The vacant side of C17 is taken to the chassis. The other end of resistor R16 is wired to the G terminal on the dynamic speaker output socket. A lead is taken from this G terminal on the dynamic speaker output socket to one end of R13, the "B" positive leads on IF1 and IF2, one end of R7, one lead of R2, and to the "B" positive 250 volt lead on the coil box. This "B" positive lead is by-passed to chassis through the fixed condenser C19. The other end of R2 is soldered to one side of C3 and to the "B" positive 150 volt lead on the coil box. The other side of condenser C3 is taken to chassis.

The remaining end of resistor R7 is joined to the screen terminal on V3 and V1 valve sockets and is by-passed to chassis through the condenser, C7. The screen terminal on V2 socket is wired to the end of R2, which is connected to the coil box. This completes the wiring of the set.

The tuning unit used in this receiver is aligned during manufacture, and unless the builder has access to a signal generator we would not advise him to attempt its re-alignment.

Switch on the receiver and allow the valves to warm. This will require approximately two minutes, as these valves are very slow in heating. After you are satisfied that the valves have had sufficient time to heat, turn the band changing switch to the broadcast position and rotate dial until a station is heard.

Keep the volume at the required level with the aid of volume control, VC. The tone of the receiver may be adjusted to suit individual taste by means of the tone control, TC.

Under test this receiver gave amazing results, especially on the short-waves. Daventry, Germany, Holland and many other countries were tuned in with the greatest of ease, while the tonal quality of the receiver was all that was desired.

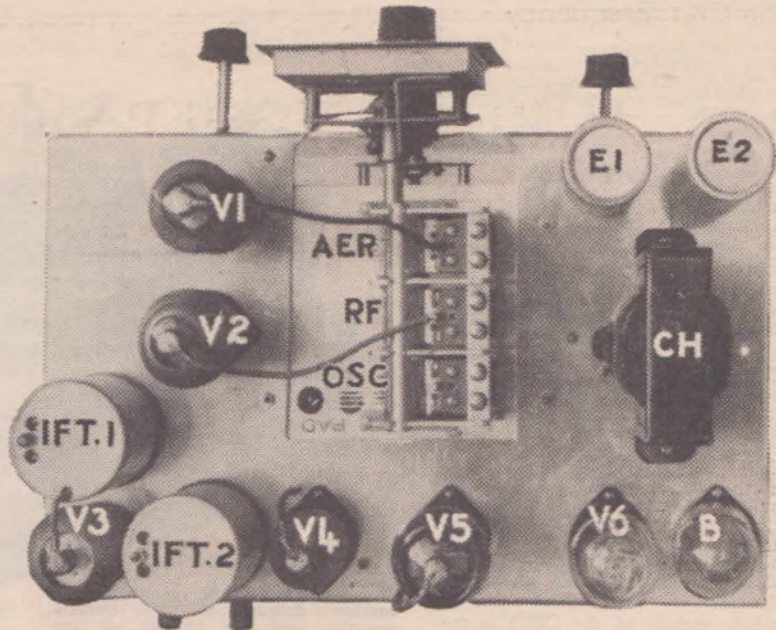

Key-lettered to agree with the circuit diagram and the wiring description, this top-chassis view of the receiver illustrates clearly the lay-out of the major components.

FOR ALL MODERN CIRCUITS THIS JOURNAL RECOMMENDS

AIR-MASTER

Radio Iron-Dust Core Litz-Wound Coil Kits

- **THE COUNTRYMAN'S CONVERTER.** Iron dust core Litz-wound special high gain I.F. unit. Optimum coupling. Fitted with electro-static shield and other ultra-efficient design features **10/6**
- **THE MELODIOUS THREE and THE SUPREME TRF THREE.** Iron dust tuned radio frequency coil kit, as featured in several Listener-In circuits working with A-C and battery, screen grid valves. Kit of aerial and R.F. coils. **13/-**
- **THE MIGHTY ATOM 3-Valve Band Pass coil kit with iron dust cores.** Aerial, Band-width and Preselector Coils. **14/3**

ALL AIR-MASTER COILS ARE DESIGNED FOR VARIABLE CONDENSERS HAVING TUNING RANGE OF 18 TO 385 MFD.

THE LISTENER IN HIGH FIDELITY 18 WATT AMPLIFIER COMPONENT KIT

AIR-MASTER has had the privilege of co-operating with the Technical Staff of "The Listener-In" in the perfecting of their remarkably efficient High Fidelity Amplifier.

The key components of this outstanding achievement in amplifier design—power transformer, filter chokes and driver transformer—have been exclusively developed by Air-Master for this especial purpose. Our success can be judged by the overall performance of driver stage and power tubes coupled by the Air-Master TYPE HF4 driver transformer—showing less than 2Db departure from linearity between 50 and 12,000 cycles.

- HF2 POWER Transformer .. 39/6
- HF3B 30 HENRY CHOKE .. 18/-
- HF3A 10 HENRY Choke .. 18/-
- AF4 DRIVER Transformer . 32/6

Enquiries are invited and will be gladly and promptly attended to, for any special purpose radio apparatus in which performance must be paramount. Our well equipped laboratory and designing staff stand ready to assist you.

AIR-MASTER RADIO CO.—131 Brunswick Rd., B'wick., Vic.

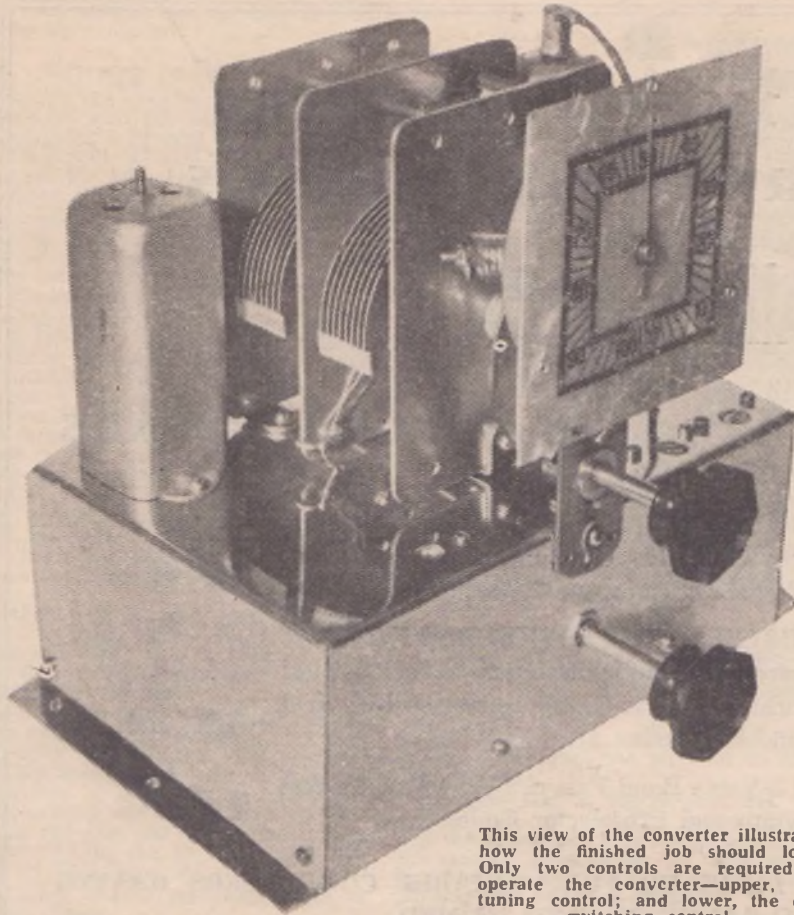

This view of the converter illustrates how the finished job should look. Only two controls are required to operate the converter—upper, the tuning control; and lower, the coil switching control.

DURING the last few years the popularity of short wave and dual-wave receivers has greatly increased, due, no doubt, to the increasing numbers of international broadcasting stations it is possible to receive with sets of this type. Those less fortunate listeners who possess straight broadcast receivers are often desirous of listening to some special short-wave programme which may not be re-broadcast by their local stations. To do this it is necessary for the broadcast receiver to be fitted with either a short-wave converter or a short-wave adaptor depending on the type of receiver with which it is to be used.

A CONVERTER is used when the receiver is either a super-heterodyne or a T.R.F. set employing two stages of radio frequency amplification.

The tuning range of the converter is from 16 metres to 25 metres and from 24 metres to 50 metres, these ranges take in the broadcast bands at 16 metres, 19 metres, 25 metres, 31 metres and 49 metres.

It is common practice today to use standard sized condensers in short wave converters of this type, but as this usually results in considerable loss of efficiency, it was decided to limit the effective capacity of the tuning gang by connecting suitable fixed condensers in series with it.

With these condensers inserted effective maximum capacity of the tuning condenser is about 170 micro-microfarads resulting in greatly improved efficiency and ease of tuning.

In order to increase the efficiency of the unit an iron core type coupling transformer is employed to transfer the energy from the plate circuit of the converter valve to the aerial winding of the broadcast receiver.

Components Reviewed

The intermediate frequency transformer is specially constructed for the job by Radiokraft Pty. Ltd. It assists in improving the gain of the combination.

The coils are wound on pieces of $\frac{3}{4}$ in. diameter former $1\frac{1}{2}$ inches long. The secondaries are wound with 26 gauge enamel wire and the primaries with 34 gauge double silk covered wire.

The Countryman's Converter

An extremely sensitive short-wave arrangement which, when used in conjunction with a broadcast receiver, will tune in most of the overseas short-wave broadcasters.

By H. R. SETFORD

In the original coils small eyelets were placed conveniently on the coil formers and the ends of the windings soldered to them. The position of the eyelets can be seen from the sketch supplied.

A start may be made by winding the high frequency section of the modulator coil. This winding is laid on at the top of the former, i.e., the end furthest from the chassis, and consists of 5 turns of 26 gauge wire spaced one diameter of the wire. This is easily done by winding on two lengths of the wire side by side, melting over it some beeswax to which a small quantity of resin has been added, and removing one of the windings. The low frequency winding of this coil consists of $5\frac{1}{2}$ turns of the same wire close wound, with a space of 5-16in. between the bottom turn of the high frequency coil and the top turn of the second coil. The ends of both the windings are soldered to the eyelets.

The aerial coupling coil is wound at the lower or earth end of the high frequency coil. It consists of four turns of 34 gauge wire wound in the same direction as the secondary.

In winding this coil care should be taken to see that one complete turn of this coil lies outside the bottom turn of the secondary before interwinding is commenced. This means that three of the four turns of this coil are interwound with the secondary while the other one is not.

This completes the aerial or modulator coil and the winding of the oscillator coil may now be commenced. As in the case of the modulator coil the highest frequency coil occupies the top of the former.

This coil also consists of 5 turns of the 26 gauge wire spaced by its own diameter. The low frequency section of the coil has five and one-third turns of the 26 gauge wire close wound and spaced five-sixteenths of an inch from the bottom turn of the high frequency

A Bad Aerial is like a leaking Waterpipe

YOUR aerial is like a pipe which carries the signals into your set. If a waterpipe is leaking, your supply is not so good as it should be; if you have an ordinary aerial, your reception is disappointing. **ONLY** with a correctly designed, scientific aerial like "NOISE-MASTER" can you enjoy fully the wonderful programmes that many European and Interstate stations are putting into YOUR aerial, but which interference and static stops you from enjoying.

The "Noisemaster" Aerial Kit embodies the wonderful American invention "Antennex"—it acts like a purifier and cleans out every trace of locally created noise and leaves the stations beautifully clear and astoundingly strong.



Specially Designed
for Perfect Reception

Stop that NOISE and STATIC and you will get a full revelation of what your receiver can do when you give it a chance. "NOISEMASTER" is guaranteed to improve your reception from 23 to 76 per cent.! Write for literature.

The "Noisemaster" Kit comprises 200ft. of special aerial wire, a dozen specially designed transposer blocks, the wonder aerial energiser "Antennex," 2 lightning arrestors, earth clamp and lead-in strip. Priced at only 52/6—the complete kit—Freight paid anywhere in Australia.

"NOISEMASTER"

VEALLS RADIO & ELECTRICAL STORES

243-249 SWANSTON ST., MELBOURNE
299-301 CHAPEL ST., PRAHRAN

168 SWANSTON ST., MELBOURNE
3-5 RIVERSDALE RD., CAMBERWELL

coil. The reaction, or feed-back, coil is wound over the bottom turn of the high frequency section of the coil and consists of ten turns of the 34 gauge wire wound in the opposite direction to the secondary. It is important that this winding is in the reverse direction to the secondary winding.

The best way to wind this coil is to place a strip of thin paper over the last two turns of the secondary, wind on the ten turns, and secure the ends with sealing wax. Next solder the ends into eyelets conveniently placed at the top of the former. Having wound the coils two small brackets must be made to support them. Sufficient space has been left at the bottom of the formers to allow a brass bolt to hold each bracket in place. The next step in the completion of the converter is to mount the various parts in the positions they are to occupy on the chassis.

The gang condenser occupies a central position on top of the chassis, whilst directly below it is mounted the wave-changing switch. To the right of the gang, the valve socket is bolted in position, as are the four trimmer condensers. The exact places occupied by these components can be seen from the plan

photograph of the completed assembly.

To the left of the gang, and against the front wall of the chassis, the padder condenser, PD, is mounted, whilst the position of the I.F. transformer may be seen from the photographs.

Mounted on the back of the chassis are the aerial and earth terminals, and the two terminals which connect to the aerial and earth of the broadcast set. These are directly below the I.F. transformer.

A hole in which a rubber grommet is to be fitted should be drilled in the back of the chassis to allow the battery leads to be taken through. Before bolting the trimmers in position, leads should be attached to them. These later connect to the switch contacts. Care should be taken in wiring these trimmers that the fixed plate connections for each of the two sets connect together, and join to the grid contacts of the coils.

The aerial or modulator coil can be seen mounted on the front wall of the chassis to the right of the switch. The oscillator coil is hidden in the photograph by the condenser C4, but is mounted directly behind the switch, and spaced about one inch from it.

Before commencing the wiring of the converter, it is necessary to provide an insulated lug on the chassis to secure the screen resistor R2, and the "B" positive leads of the coils and I.F.T. Once this has been done, the wiring may be commenced by soldering a heavy tinned copper wire lead to the wipers on the moving plates of the gang condenser. This lead connects to the moving plate lug of the padder, PD, and solders to a lug placed under one of the holding bolts for the KK2 socket. Solder to this wire all those leads described as returning to earth in the wiring description.

Wiring Description

Continue the wiring by soldering the lead from the bottom of the aerial or modulator coil to the arm of switch 1. In wiring the switch the sections are connected in the following manner:—

On examining the switch it will be found to be six pole double throw, i.e. six single pole double throw switches on the one shaft. The switch should be mounted with one of the arm or centre contacts uppermost. This section

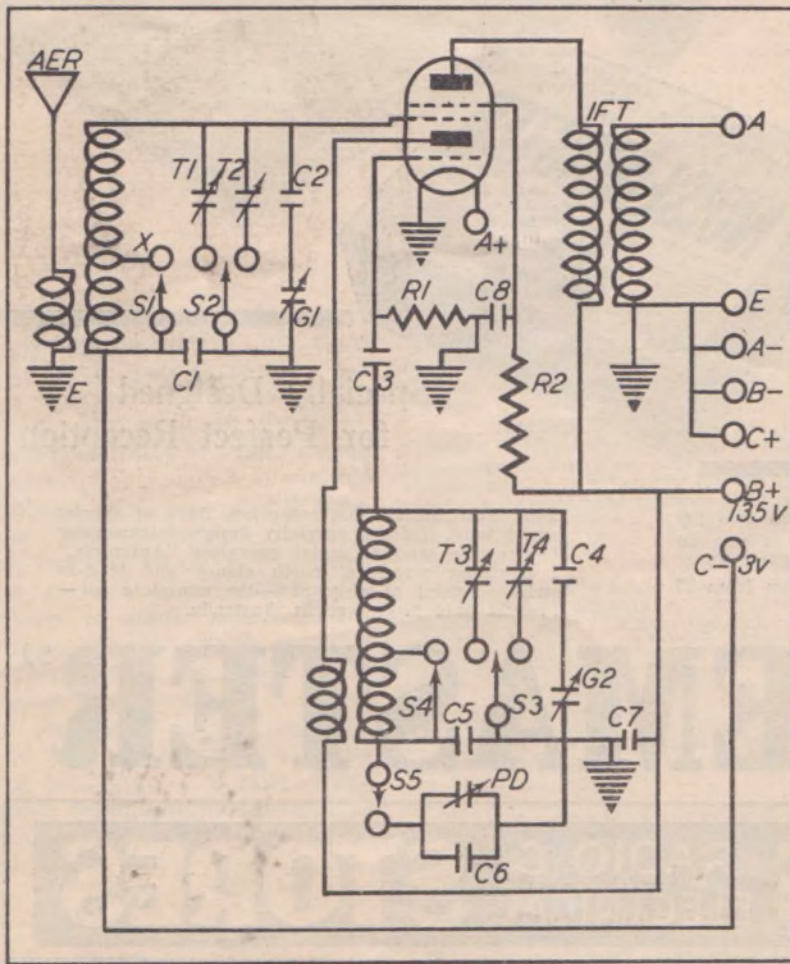

Circuit Diagram and Parts List for The Countryman's Converter

Chassis measuring 8 inches by 5½ inches by 3 inches.

C1, C8: .1 mfd. tubular condenser (T.C.C.).

C2, C4: .0003 mfd. mica condensers (T.C.C.).

C3: .001 mfd. condenser (T.C.C.).

C5: .003 mfd. condenser (T.C.C.).

C6: .004 mfd. condenser (T.C.C.).

C7: .5 mfd. tubular condenser (T.C.C.).

G1, G2: Two gang condenser .000385 mfd. (Complete with dial.)

I.F.T.: Special 550 K.C. Iron core intermediate transformer (Radiokraft).

R1: 50,000 ohm 1 watt resistor (I.R.C.).

R2: 10,000 ohm 1 watt resistor (I.R.C.).

S1, S2, S3, S4, S5: Six pole double throw wave change switch. (Yaxley.)

T1, T2, T3, T4: Trimmer condensers. (Radiokes.)

Valve: One Philips type KK2 (or Mullard replica) with socket.

Sundries: Hook-up wire, nuts and bolts, rubber grommet, two knobs, 465 k.c. padder condenser, two pieces of ¼-inch former, 1 3-8 inch long, reel of 26 gauge enamel wire, 1oz. of 34 D.S.C. wire and a few small eyelets.



PALEC

TESTING EQUIPMENT

A COMPLETE RANGE FOR RADIO
LABORATORY OR SERVICE MAN

Comprising the
Multitester, Analyser-Selector, Valve Tester, All-
wave Oscillator, Vacuum-Tube-Voltmeter

THE above set of instruments makes a complete outfit for the Technician. Every radio measurement met in practise can be made. You can generate your own test signals at any frequency, supply it to a radio chassis, line up, set local oscillator, measure stage gain, overall gain, selectivity, sensitivity, audio distortion and output, test valves, measure characteristics. Test all components, A.V.C. voltages and all DC and AC measurements. A man equipped with PALEC apparatus need not fear competition, for he is able to make an accurate diagnosis in a minimum of time.

- (A) **MULTITESTER**—This 22 range instrument is the backbone of most tests. Measures AC and DC Volts from .1 to 1000 volts. 10 microamperes to $\frac{1}{4}$ ampere. 1 Ohm to 10 megohm resistance. 20 Ohms to 1 megohm impedance. 1 Henry to 10,000 Henrys inductance. .001 uF to 10 MF capacity (electrolytic or paper). Electrolytic condenser leakage. Has its own AC and DC supply built in. Only two range switches with two positions each. Price £13/10/.
- (B) **ANALYSER-SELECTOR**—In conjunction with a Multitester or other instrument this enables all voltage, current and resistance measurements on a radio chassis to be made from any type of valve socket. Price £2/19/6.
- (C) **VALVE TESTER**—Checks all English, American and Dutch Valves, including every latest release. Also applies a test for micro leakage on HEATED Valves. Easy to read Valve Chart. Price £11/5/.
- (D) **ALL WAVE OSCILLATOR**—This new release is a complete Signal Generator when used with a Vacuum-Tube-Voltmeter. Covers I.F. to highest R.F. by 5 bands, using fundamental frequencies. The capacity attenuator—a 1935 development—is effective down to microvolts at all frequencies. Calibrated in reduction ratios and decibels. Output, c.w. or modulated at 400 c.s., 30 per cent. depth. Also 400 c.s. output for Audio testing. Ideal for the service man. Battery operated and completely shielded. Price £11/10/.

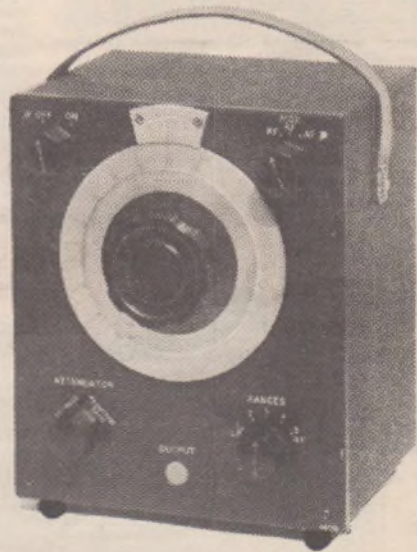

- (E) **VACUUM-TUBE VOLTMETER**—Embodies very advanced design. Metal measuring Tube at end of 3ft. flexible lead. Has no grid lead and does not suffer from "pick up." Three ranges cover .1 volt to 50 volts AC at any frequency from 50 c.s. to R.F. DC ranges similar. Uses 150 microamp. Meter which also operates as 6666 Ohms per volt Meter on 10 volt and 100 volt ranges. Built in power supply. Price £11/10/.

All the above instruments are the same size:—7 $\frac{1}{2}$ in. x 8 $\frac{3}{4}$ in. panel, 6in. deep. Combinations available in black leatherette lidded cases. A & B, £16/10/; A, B, & C, £26/10/; A, B & D, £26/10/. Other combinations to order, prices on application. All prices subject to sales tax.



Write for Illustrated Catalogue to

THE PATON ELECTRICAL INSTRUMENT CO.
90 Victoria Street, Ashfield, Sydney. Tel. UA1960

Makers of the PALEC moving coil meter and PALEC Cathode Ray Oscillograph.
WRITE FOR COMPLETE DESCRIPTIVE CATALOGUE OF OUR LINES.

Distributors:—Melbourne, A. H. Gibson (Electrical) Co. Pty. Ltd. Sydney: Bloch & Gerber, Fox and MacGillicuddy, Lawrence and Hanson. Wellington, N.Z.: The Electric Lamp House Ltd.

switches out the low frequency portion of the aerial or modulator coil, whilst the next section to the right, moving in a clockwise direction, switches the trimmers for the modulator coil. The third section to the right switches the trimmers for the oscillator coil, whilst the fourth section switches the oscillator coil itself. The fifth section switches the padder shunt condensers in on the lower frequency band, whilst the sixth section remains vacant.

Whilst wiring the switch contacts it is advisable to set the switch in the high frequency position, as this will act as a guide when connecting the tapings on the coil to the right contact of the switch.

The tapping on the modulator coil connects to the high frequency contact of switch one, whilst to the grid contact of this coil is soldered one side of the condenser, C2. The remaining contact of C2 connects to the fixed plate contact of the section G1 of the gang condenser. The fixed plate contacts of the trimmers, T1 and T2, also join to the grid contact of the modulator coil. The moving plate contact of T1 connects to the high frequency contact of S2, whilst the vacant contact on this section of the switch connects to the remaining contact of T2. The arm contacts of S2 and S3 join together and solder to earth. The high frequency contact of S3 connects to the moving plate contact of T3, whilst the corresponding contact of T4 connects to the low frequency contact of S3.

To the arm contact of S4 is connected the bottom contact of the oscillator coil and one side of the .003 mfd. condenser C5. The remaining contact of C5 and one

side of the .004 mfd. condenser, C6, solder together and connect to earth. Connect the arm of S5 to the arm of S4. Connect together the remaining contact of the condenser, C6, and the fixed plate contact of the padder condenser, PD, and join them to the low frequency contact of S5.

The fixed plate contacts of the trimmer condensers, T3 and T4, connect together and solder to the grid contact of the oscillator coil. From this same grid contact the oscillator grid condenser, C3, solders to the oscillator grid lug on the KK2 valve socket, from which point the oscillator grid leak, R1, connects to earth. One side of the band spread condenser, C4, solders to one of the vacant contacts of the number six section of the wave change switch, whilst the remaining contact of C4 connects to the grid contact of the oscillator coil.

The lead from the fixed plates of the G2 section of the gang condenser connects to that contact of the condenser, C4, which joins to the vacant contact of the switch.

From the arm of S1 connect a .1 mfd. condenser to earth and solder along lead to the junction of the arm of S1 and the condenser. This lead should be passed through the rubber grommet at the back of the chassis and will later be connected to a negative potential of 3 volts, which is the bias for the modulator grid of the KK2.

The remaining lugs on the KK2 socket can now be connected. Start by joining the negative filament terminal of the socket to earth. To the positive lug of the socket solder a long lead and pass

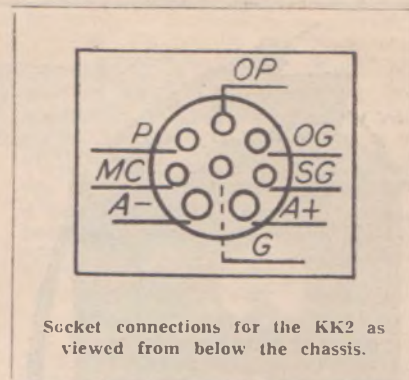

Socket connections for the KK2 as viewed from below the chassis.

it through the grommet at the back of the chassis. This will become the "A" battery positive lead.

The metal coating lug, MC, of the KK2 socket joins to earth whilst the plate lug on this socket connects to the plate contact of I.F.T.

The "B" positive contact of I.F.T. connects to the insulated lug provided for the "B" positive connections. The resistor, R2, connects from this lug to the SG contact of the KK2 socket, from which point the condenser C8 joins to earth. The OP contact of the KK2 socket connects to that end of the oscillator feed-back coil nearest the top of the former. If this is connected incorrectly the oscillator portion of the KK2 will fail to oscillate and the converter will not function. The remaining contact of the oscillator feed-back coil connects to the "B" positive lug to which a long lead should be connected and passed through the rubber grommet for connection to the "B" battery.

The condenser C7 connects from the "B" positive lug to earth. The two remaining leads from I.F.T. connect to the terminals adjacent to that component one of which "A" is insulated from the chassis. The aerial terminal, which should also be insulated from the metal chassis, connects to that end of the aerial winding farthest from the top or grid contact of the modulator coil. The remaining contact of the aerial coil joins to earth.

The wiring is completed by connecting the control grid pip on the top of the KK2 to the grid contact of the modulator coil, joining a long lead to the earth terminal of the converter, and passing it through the grommet. This lead is the "A" negative, "B" negative and "C" positive lead for the batteries.

Before any attempt is made to hook up the converter the wiring should be carefully checked for faults. If everything is in order the batteries may be connected and the converter attached to the broadcast receiver. In connecting the batteries the maximum supply for the converter should be 135 volts, while a negative bias of three volts should be applied to the grid of the modulator section of the KK2.

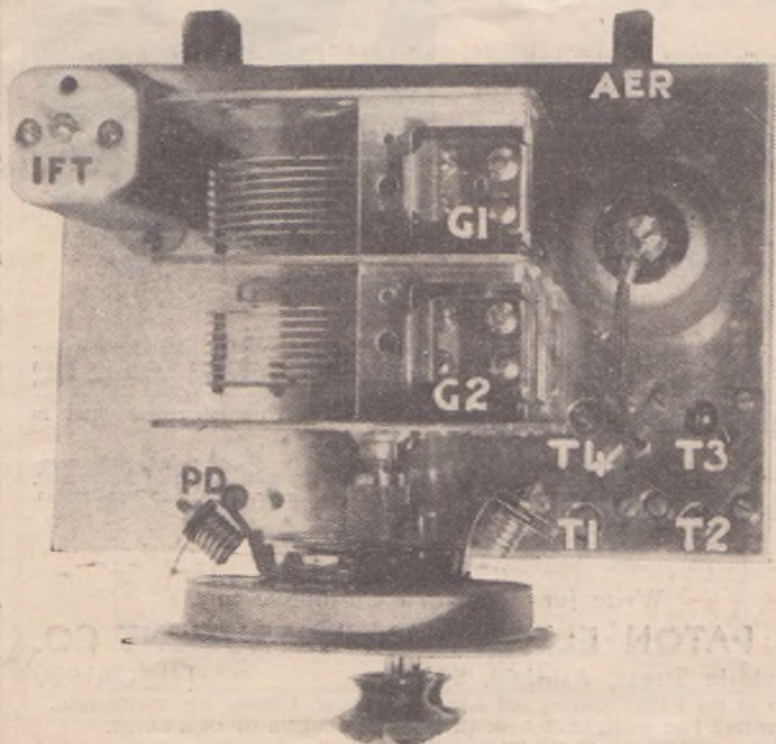

A plan view of the converter showing the layout of parts on top of the chassis. All components are keyed to correspond with the written description of the converter.

Converter Hook-Up

To attach the converter to a receiver first remove the aerial and earth wires from the receiver and attach them to their correct terminals on the converter. Connect a wire to the insulated output terminal of the converter and join this wire to the aerial terminal of the receiver. The remaining terminal on the converter connects to the earth terminal of the receiver.

The converter should now be in operating condition, and on tuning the condenser slowly signals will be heard. Before the trimmers are touched it will be necessary to tune the I.F. transformer. First tune the broadcast receiver to a position slightly higher than 3AR where no station is being received. Then tune the converter till a signal is received. With the signal coming through adjust the trimmers on I.F.T. for best results. It will be found that one of these trimmers will affect the tuning of the converter and it will be necessary to retune the station each time an adjustment is made. It must be borne in mind that each time the converter is to be used the broadcast receiver must be retuned to exactly the same spot as when the converter was first adjusted if results are to be duplicated.

Having carried out these adjustments, the next step is the adjustment of the trimmers for each band. A start may be made by opening out the oscillator trimmer for the high frequency band, i.e., low wavelength, and tuning a station on this band.

The high frequency trimmer, T1, should then be adjusted for best signal strength. The adjustment for the lower frequency band should be made so that a station received at the top end of the

The oscillator trimmer, T4, will govern the frequency range of the coil to a large extent, and adjustment of this trimmer will bring the desired result. When this adjustment has been made the trimmer, T2, may be adjusted for loudest signals.

This completes the adjustments, and stations on the various bands should be received at excellent strength during their peak hours. It must not be thought that stations will be received on all the bands at any one time; this is not so. The listener will have to pick his hours of listening to suit the period of best reception for the particular band on which the station operates.

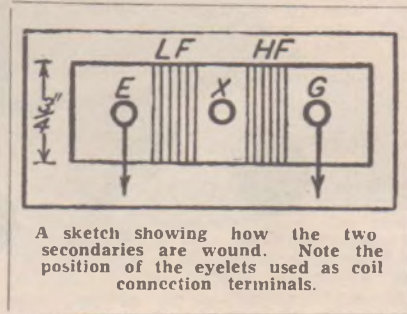

high frequency band is received on the low frequency band with the condenser plates in the full-out position.

The converter can be confidently recommended to those users of battery broadcast receivers who are desirous of breaking into the field of short-wave reception. Connected to a standard battery super-heterodyne, the converter behaved splendidly, stations in all parts of the world being received at excellent strength. The London stations are being received at exceptionally good strength at the present time, and full loud-speaker reception is to be obtained from the set-up described.

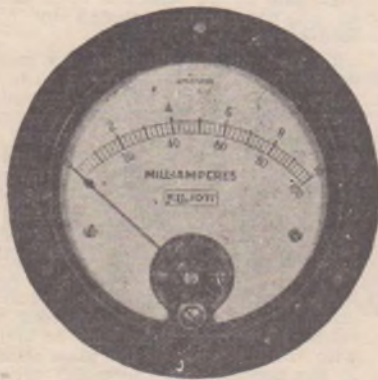

Stocks of Miniature Instruments for Panel Mounting available in the following types for A.C., D.C. and R.F. Measurements. Moving Coil, Moving Iron, Thermo-Couple and Metal Rectifier Patterns.

SOLVING YOUR INSTRUMENT PROBLEMS

SIEMENS ELLIOTT

BRITISH RADIO INSTRUMENTS

ASSURE
ACCURACY

RELIABILITY and SERVICE

Amateurs are invited to submit to us their problems. Stocks are available to meet all requirements.

SIEMENS (AUST.) PTY. LIMITED

SYDNEY

MELBOURNE

BRISBANE

ADELAIDE

H. C. LITTLE & CO. LTD., PERTH.

F. H. FEARON, NEWCASTLE

W. & G. GENDERS, LAUNCESTON AND HOBART, TASMANIA.

The Supreme T.R.F. "3"

Complete constructional information on an outstanding t.r.f. receiver employing metal valves and specially developed iron-dust coils, is provided in this article.

By A. K. BOX

RADIO'S most recent innovation, the employment of iron-cored coils in radio and intermediate frequency circuits, seems likely to revolutionise all previous conceptions of coil efficiencies. With its high "Q" or efficiency factor the iron-cored type of coil not only boosts the sensitivity of the receiver with which it is associated, but considerably improves its selectivity.

Both advantages are of exceptional value to the receiver designer, although the first, by reason of its effect upon the number of valves required to obtain a given set of results, is the most spectacular side of the iron-cored story.

Recent measurements by Mr G. Williams, Chief Engineer of one of Melbourne's largest radio factories, show that the iron-cored coil, small though it is in physical structure, has a higher "Q" factor than the most efficient air-cored coil it is possible to construct—one wound with 26 gauge cotton covered wire on a 2½ inch diameter former. The relative figures are something like this: The large coil has a "Q" factor ranging from 185 at 1500 k.c. to 160 at 550 k.c., whilst the iron-cored coil is practically flat throughout

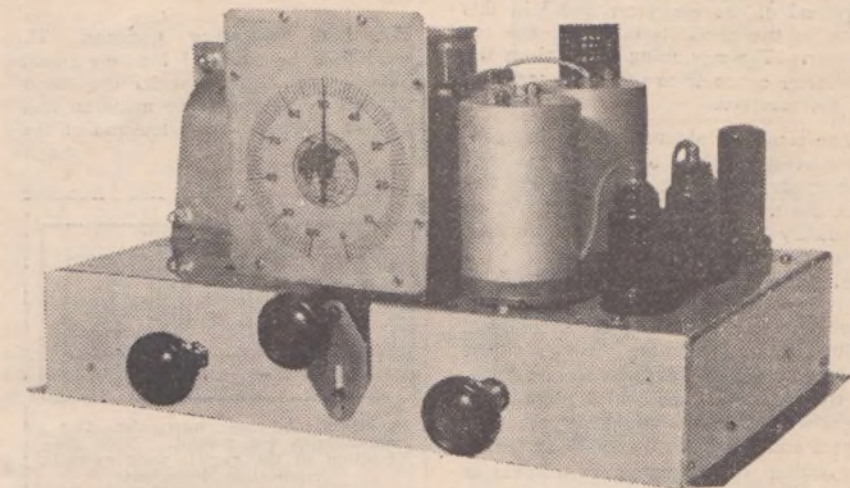

its tuning range with a "Q" factor of 195.

Another interesting point is that although these coils raise the efficiency of the super-heterodyne type of receiver to almost unprecedented heights, they also have placed the tuned radio frequency receiver again on the map. With simple types of t.r.f. sets equipped with iron dust coils it now is possible to attain sensitiveness which makes interstate reception a certainty. The ease with which such t.r.f. sets can be built and made to work means, then, that the novice set constructor, if he requires a receiver capable of distant reception, is not forced to tackle what are to him the difficulties of the super-het.

Here are some results obtained with this simple t.r.f. receiver built. It has a sensitivity ranging from 27 to 45 microvolts throughout its tuning range. The stage gain from the r.f. stage reaches the phenomenal figure of 122 to 1000 k.c. and the set's selectivity is sufficient to ensure sufficient separation between all but the most closely placed stations.

generative detector, they become more than amazing.

Furthermore, and this is a big point, as everyone who has built a high gain

set of any type will agree, the fact that such performance is obtained without any tendency towards instability, is remarkable. The components were simply wired into circuit, the tuning gang aligned, and the receiver placed on the air. There was none of that grunting or growling met with in high gain t.r.f. sets when the reaction condenser is brought towards the oscillation threshold. The reason for this was that every bit of the set's efficiency was due to the high gain of the associate coils, and not to r.f. regeneration caused by stray feed-backs.

To sum up the situation, we may say definitely that an iron-cored t.r.f. three valve set can be made as sensitive as many of the air cored four valve super-heterodynes, that it is cheaper and easier to build and get going, and that its selectivity does not fall far short of that of the super-het. Having touched upon the possibilities of such a t.r.f. receiver, we now shall give constructional details of the original model built up in our laboratory.

As can be seen from the circuit diagram, this receiver employs four metal tubes. If desired, these can be replaced with similar types in the glass series, as in the present case the metal valves do not exercise any great influence on the set's performance.

The first tube is a 6K7 r.f. amplifier, which is impedance coupled to the detector valve, a 6J7 used as a leaky grid detector. The 6J7 in turn is resistance coupled to the type 6F6 output pentode. The rectifier is a metal type 5Z4. It will be noticed that the number of components in the receiver has been reduced to the absolute minimum compatible with satisfactory performance.

The heart of the receiver is its coil system. These coils were specially developed for The Listener In by Mr. F. G. Canning, chief engineer of Radiokraft Pty. Ltd., 131 Brunswick Road, East Brunswick. They are of particular interest because, in addition to employing iron dust cores, they make use of an extremely effective high impedance primary system.

WHEN it is considered that these results are obtained from a simple receiver, employing but one radio frequency stage and a re-

Coil Details

The aerial coil, AER, consists of the high impedance primary winding, L1, inductively coupled to the secondary, L2, and capacity coupled to this winding by means of the coupling condenser, C. The r.f. transformer, R.F., consists of the primary, L3, which is a high impedance radio frequency choke coil of special design, the secondary winding, L4, which is similar in design to L2, another coupling condenser, C, and the reaction winding, L5.

The primaries of these coils, L1 and L3, resonate towards the low frequency end of the tuning scale, whilst the high frequency transfer is chiefly handled by the coupling condensers, C. The characteristics of this tuning system are that, in its commercial form, it is very flat in response from the lowest to the highest frequencies, and that its gain is exceptionally high.

The gain feature is influenced by the fact that, besides having iron dust cores, the coils are wound with high-grade litzendraht wire noted for its efficiency at radio frequencies. Incidentally, although not provided for in the commercial design (the coils are set at optimum) adjustment of the condenser C makes it possible to shift the gain characteristics of the coils throughout a wide frequency range.

Although the circuit is quite straightforward a brief survey of it may assist the novice. Tuning of the AER and R.F. secondary windings is carried out by the G1 and G2 sections respectively of the two gang tuning condenser. The R.F. valve is fed with the maximum plate supply voltage of 250, as are the

plates of the 6J7 detector and the 6F6 audio amplifier. The 100 volt potential required for the screen of the 6K7 r.f. valve is derived from a convenient tap on the 25,000 ohm voltage divider VD. The screen grid of the 6K7 is by-passed with a 1 mfd. condenser, C2, whilst a similar capacity is used to by-pass the screen of the 6J7, which, for detection purposes, must be returned to a 25-volt tap on VD.

Volume control is effected by means of a 5000 ohm. potentiometer connected between the 40 volt tap on VD and earth, and having its arm returned to the cathode of V1 through a 300 ohm resistor. The purpose of this resistor, R1, is to establish a minimum bias of 3 volts on the r.f. valve even when VC is set at the maximum position. The cathode of V1 is by-passed with a .1 mfd. condenser, C1.

The R.F. secondary winding, L4, is fed to the control grid of the detector valve, V2, through a .0001 mfd. grid condenser, C3. The grid leak, R2, has a resistance of 2 megohms and is connected between the control grid of the 6J7 and ground. A shunt-fed reaction system has been used to obtain the smoothest control. This consists of the plate winding, L5, and the 23 plate midget condenser, M, connected in series between the 6J7 plate and ground.

One of the essential parts of the circuit is the radio frequency choke, RFC, connected between the 6J7 plate and the plate resistor, R3. Unless this choke coil provides a complete bar to the passage of radio frequency currents the receiver is likely to become unstable owing to r.f. getting back to the detector and

r.f. valves via the audio amplifier. In order further to guard against this possibility a small by-pass condenser, C5, of .0001 mfd. capacity, is connected on the resistor side of RFC and taken to earth. In order to obtain the maximum audio gain and yet maintain good tonal quality the plate resistor, R3, has a resistance of 250,000 ohms and the grid resistor, R4, is a 500,000 ohm resistor. The coupling condenser, C6, is of the mica-dielectric type and has a capacity of .02 mfd.

The audio amplifier is biased in the conventional manner by means of a 400 ohm resistance connected between cathode and ground. This resistance is by-passed with a 25mfd. condenser, C7. In the output circuit we find a tone control arrangement consisting of the .02 mfd. condenser, C8, and the 10,000 ohm resistance, R6, connected in series between the plate and screening grid of the 6F6.

Power Supply

The power supply system is normal in type, and consists of a transformer capable of delivering 385 volts at 60 m.a. It is provided with a five-volt rectifier winding and a 6.3 volt winding for the valve filaments. Filtration is effected by means of the 2500 ohm loud speaker field winding and the two 8 mfd. electrolytic condensers, E1 and E2.

The receiver is built up on an aluminium chassis measuring 13 inches in length, 8 inches in width and 2½ inches in depth. The key-lettered top illustration of the original receiver shows that the power transformer has been mounted in the rear left-hand corner, the two electrolytic condensers E1 and

SCHMATIC CIRCUIT DIAGRAM AND PARTS LIST
for the Supreme T.R.F. "3"

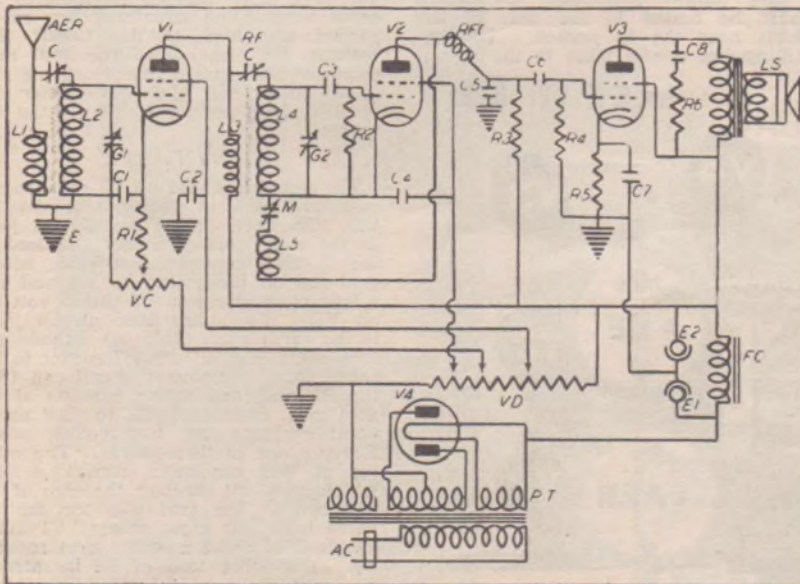

- C6, C8.—.02 mfd. Mica Condensers. (T.C.C.)
- C7.—25 mfd. 25 volt Electrolytic Condenser. (T.C.C.)
- E1, E2.—8 mfd. 500 Volt Electrolytic Condensers. (T.C.C.)
- FC.—2500 Ohm Loud Speaker Field Winding.
- G1, G2.—Two Gang Tuning Condenser to suit Coil Kit.
- LS.—Loud Speaker Matched to 6F6 Valve and with 2500 Ohm Field. (Amplion, Rola).
- M.—23 Plate Midget Variable Condenser.
- PT.—Power Transformer 385-0-385 at 60 m.a.; 5 v. at 2 a.; 6.3 v. at 1.5 a.
- R1.—300 Ohm 25 m.a. W.W. Resistor.
- R2.—2 Megohm 1 Watt Resistor.
- R3.—250,000 Ohm 1 Watt Resistor.
- R4.—500,000 Ohm 1 Watt Resistor.
- R5.—400 Ohm 50 m.a. W.W. Resistor.
- R6.—10,000 Ohm 1 Watt Resistor. (All I.R.C.)
- VALVES.—One Each Types 6K7, 6J7, 6F6 and 5Z4 with sockets to suit. (Mullard, Philips, Radiotron, Raytheon).
- VC.—5000 Ohm W.W. Potentiometer.
- VD.—25,000 Ohm Voltage Divider.

SUNDRIES.—Nuts, bolts, hook-up wire, tinned wire, two grid clips, knobs, dial, rubber grommet, power flex, one four-pin socket, two terminals.

CHASSIS.—Aluminium measuring 13 inches x 8 inches x 2½ inches.
AER, R.F.—Special Iron Dust Coils (Radiokraft).

C.—(See Text).
C1, C2, C4.—.1 mfd. Tubular Condensers.
C3, C5.—.0001 mfd. Mica Condensers.

E2 being mounted alongside it. The gang condenser is mounted centrally on the chassis. Alongside it are the AER and R.F. coils, the former being nearest to the front of the receiver. The three valves, V1, V2 and V3, are mounted in the order mentioned along the right hand end of the chassis. Between V3 and the electrolytic condensers, along the rear of the chassis, is to be found the rectifier valve, V4.

The front view of the receiver shows that three controls are employed. The central one is the tuning control. The reaction condenser is at the left and the volume control at the right. Along the rear of the chassis we find that the aerial and earth terminals and the socket for the loud speaker plug have been mounted. At the left hand end of the chassis a hole is drilled and a rubber grommet fitted to provide an outlet for the power supply cable.

Under-Chassis Component

The only components to be directly mounted to the underside of the chassis are the voltage divider, VD, the fixed condensers, C5, C6 and C8, and the radio frequency choke, RFC. Incidentally, the volume control, VC, should be insulated from contact with the chassis by means of bakelite washers. The remainder of the under-chassis components are wired directly into circuit.

In mounting the valve sockets keep the filament contacts for the 6K7 and 6J7 towards the right-hand end of the chassis, and face the filament contacts for the 6F6 and 5Z4 sockets towards the rear of the chassis.

The wiring of the receiver should be started by running a lead from one of the 6.3 volt lugs on PT to one filament lug on the sockets for V1, V2 and V3. A second lead is taken from the remaining 6.3 volt filament lug to the remaining filament lug on these three sockets. These two filament leads should be twisted together to prevent hum troubles.

Next run a lead from one of the high voltage lugs on PT to one plate lug on the socket for V3, and return a lead from the other plate lug on this socket

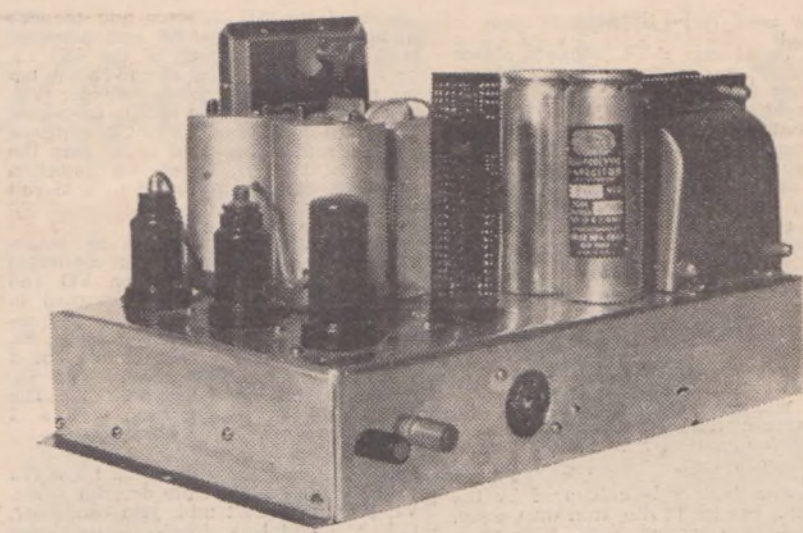

A rear view of the completed receiver, showing the mounting positions of the aerial and earth terminals and the loud speaker socket.

to the remaining high voltage lug on PT. The high voltage centre-tap lug on PT should be taken to chassis. One of the five-volt filament lugs on PT is joined to the filament lug on the socket for V4. The other five-volt lug on PT joins to the cathode lug on V4 socket, thence to the positive lug on E1 and to one of the field lugs on the loud speaker socket.

The other field lug on this socket is joined to one of the input transformer lugs and to the positive lug on E2. From these joined lugs on the l.s. socket take a lead to the screen grid lug on the socket for V3, and continue this lead to the positive end of the voltage divider, VD. One lead of the resistor, R6, is soldered to the screening grid lug on the V3 socket, the other lug on this resistor being soldered to one lug of the .02mfd. condenser, C8, which should be bolted to the rear of the chassis near the l.s. socket. The remaining lug on C8 joins to the vacant

lug on the l.s. socket and to the P lug on the socket for V3.

Solder the positive lead of the electrolytic condenser, C7, and one lead of the 500-ohm resistor, R5, to the cathode lug on the socket for V3. The remaining leads of these two components should solder to an earth wire, which has been brought down through the chassis from the moving plate wipers on the gang condenser and taken around to join to the earth terminal. This lead is run with 16-gauge tinned copper wire.

Solder one lead of the .5 megohm resistor, R4, to one lug of the .02 mfd., condenser, C6, which has been bolted to the right hand end of the chassis between the sockets for V2 and V3. From this same lug on C6 run a lead to the control grid lug on the socket for V3. The other lead on R4 joins to the earth wire. The remaining lug on C6 carries one lead of the 250,000 ohm resistor, R3, one lug of the .0001 mfd. condenser, C6, and a lead from one side of the choke coil, RFC. The other side of RFC joins to the P lug on the 6J7 socket.

Wiring

The remaining lead on R3 joins to the maximum end of the voltage divider, VD. The free end of the divider joins to the earth wire. Solder the lead of the .1 mfd. condenser to the screen grid lug on the socket to V2, and run a lead from this point to the 25 volt tap on VD. The other lead on C4 joins to the earth wire. Join the cathode and suppressor lugs on the 6J7 socket to the earth wire. Remove the coil can from the RF coil, and solder one lug of the .0001 mfd. condenser, C3, to the solder point carrying the two yellow wires. Remove one of these wires. The other lug of this condenser carries a lead which goes out through the side of the coil can to the grid clip for the 6J7 valve. To this same side of C3 solder one lead of the 2 megohm grid resistor, R2. The other lead of R2 is soldered to the coil supporting bracket, care being taken to see that the grid leak does not come in contact with any of the coil or connecting leads.

Replace the coil can, and proceed with the wiring of this coil by joining the Black lead to the earth wire, and the

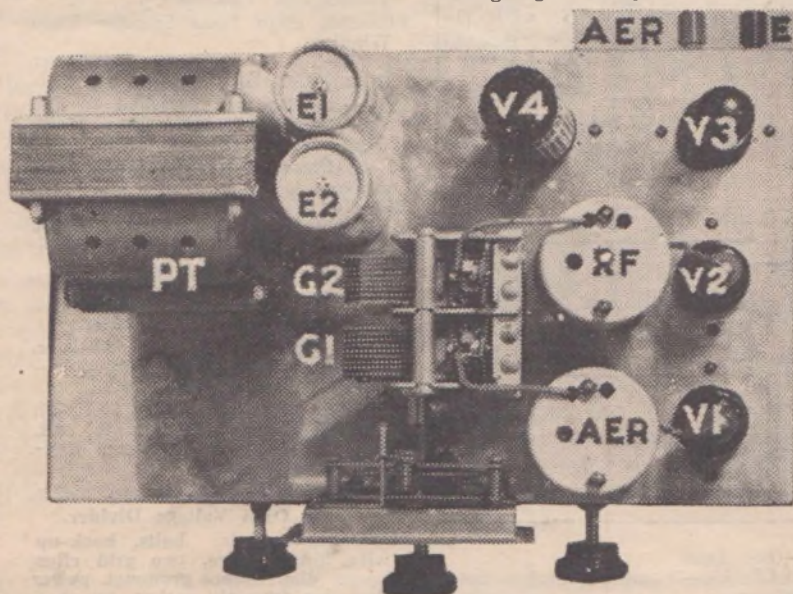

Key-lettered to agree with the components list and the point-to-point wiring description, this top chassis illustration of the receiver shows the details of component lay-out.

Yellow lead to the G2 section of the gang condenser. Solder the Red lead to the plate lug on the 6J7 socket, and join the White lead to the fixed plate lug on the midget condenser, M. The Blue lead from the RF coil joins to the plate lug on the 6K7 socket, whilst the Green goes off to the maximum tap on the voltage divider, VD.

The screening grid lug on the 6K7 socket has soldered to it one lead of the .1 mfd. condenser, C2, and a lead which goes to the 100 volt tap on VD. The other lead on C2 joins to the earth wire. The cathode and suppressor grid lugs on the 6K7 socket are joined together and carry one lead of the 300 ohm resistor, R1, and one lead of the .1 mfd. condenser, C1. The other lead on C1 goes to the earth wire, whilst the remaining lead on R1 joins to the centre lug on the volume control potentiometer, VC. One of the outside lugs on VC joins to the earth wire, whilst the other outside lug is wired to the 40 volt tap on VD.

Take the braided lead from the AER coil to the aerial terminal on the chassis. Join the White and Black leads to the earth wire. The Yellow leads on the AER coil are taken to the G1 section of the gang condenser, and to the grid clip for the 6K7 valve. This completes the wiring of the receiver, except for the connection of the power supply leads to the correct voltage lugs on the power transformer, PT.

When this has been done, plug in the valves and loud speaker, attach the aerial and earth leads, and switch on the power. Allow the receiver to warm up for a moment or two, and turn the volume control to the "full-on" position. Leaving the reaction condenser set at the "all-out" position, tune to a low wave-length station such as 3XY, and very carefully adjust the G2 and G1 trimmers for loudest signals.

It will be found desirable to keep these trimmers as wide open as possible, in order to get the desired coverage at the high frequency end of the band.

The all-round results obtained with this little receiver, are, we believe, the maximum possible from any set using a similar number of valves. Considering its low constructional cost, and the ease with which it can be built, its performance ranks it as an ideal receiver for the set builder who is after real results without too much trouble or expense.

THE KEY TO PERFECT RECEPTION

FERRANTI

RADIO PARTS

Give your Receiver a fair chance by constructing it with the best materials available. Ask for and see you get the world-famous "FERRANTI" PARTS. The reliability of "FERRANTI" equipment is unquestioned, and assures perfect reception at all times.



AUDIO PUSH PULL AND OUTPUT TRANSFORMERS

These are available in a wide range and are the accepted standard of Transformer quality. For best results you must use "FERRANTI" Transformers.

FERRANTI



FERRANTI RADIO METERS

The use of these reliable instruments has done much to bring Radio to its present state of efficiency. "FERRANTI" Meters are available in a complete range of D.C. and A.C. measurements and types for A.F. supplies as well as types for use in R.F. Circuits.

Sole Agents:

NOYES BROS. (Melbourne) PTY. LTD.

597-603 Lonsdale Street, Melbourne, C.I.

Phone Cent. 10104 (9 lines).

Also at
HOBART LAUNCESTON ADELAIDE

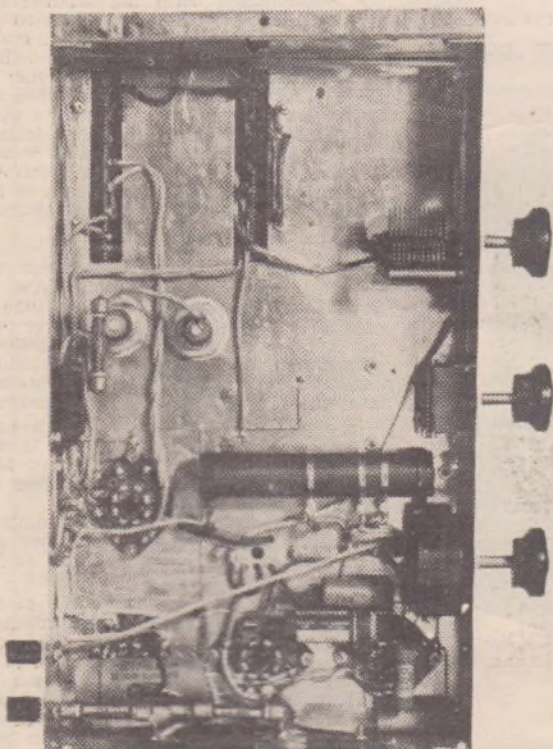

This underneath view of the receiver chassis shows how the various components have been arranged and wired.



True Fidelity With Pentodes

A Compact Audio Amplifier

An answer to the pentode sceptic! A moderately powered amplifier which is capable of providing real tonal quality.

By P. R. DUNSTONE

MANY derogatory remarks have been passed about the pentode valve, insofar as its faithful quality-reproducing capabilities are concerned. Frequently it is heard that it is an utter impossibility to obtain tonal fidelity from a receiver which employs a pentode tube in the output stage. These statements are groundless, and are largely due to inability of the engineer to obtain the desired quality from the valves. Provi-

ded an amplifier using pentodes is correctly designed in the first place, there is no reason why the reproduction from it should not compare with that received from any triode combination of valves used in the same basic circuit.

To prove this contention we built up an amplifier circuit in which to some people would appear to employ the worst possible valve combination, two pentode tubes.

BEFORE entering on a technical description of the actual amplifier, let us give a brief outline of the characteristics of the tubes used in this design.

The type 6B7S tube, which is used as the driver for the 42, is one of the latest types developed in Australia by the technicians of the A.W.A. Valve Co. It is a multi-element valve which incorporates two diodes and a pentode which may be used as an amplifier at either intermediate or audio frequencies. In this amplifier we are using only the pentode section of the tube, the diode plates being completely ignored.

A disadvantage with the original 6B7 was that it could only be operated at a fixed bias and, therefore, was easily overloaded. The super-control 6B7S can be operated in a similar manner to the 58 and other variable mu tubes inasmuch as it is possible to apply a variable bias to the tube. With this feature in the construction of the valve, it will be seen that it offers an admirable means for controlling the volume of the amplifier, by means of a variable cathode resistor.

The 42 valve employed in the output stage is the 6 volt series, replica of the 2A5, and is a heater-cathode type of power amplifier pentode. This tube is capable of giving a reasonably large output with a relatively small input-signal voltage. Because of the heater-cathode construction, a uniformly low hum-level is attainable in power amplifier design.

In this circuit the 42 has been used as a Class A audio amplifier, and is capable of delivering a power output of 3 watts. This provides ample volume for average requirements.

Having mentioned the salient points of the valves used in the amplifier, we will now analyse the actual amplifier circuit in which these valves are employed.

On referring to the schematic circuit diagram, it will be seen that input is fed through a small coupling condenser C1 to the pentode grid of the 6B7S (VI.). Should this amplifier be only used for the reproducing of records, the condenser C1 can be omitted from the circuit, since it is only necessary when used in conjunction with a radio detector or similar system.

The volume is controlled by VC, which is wired in the cathode lead of VI. By

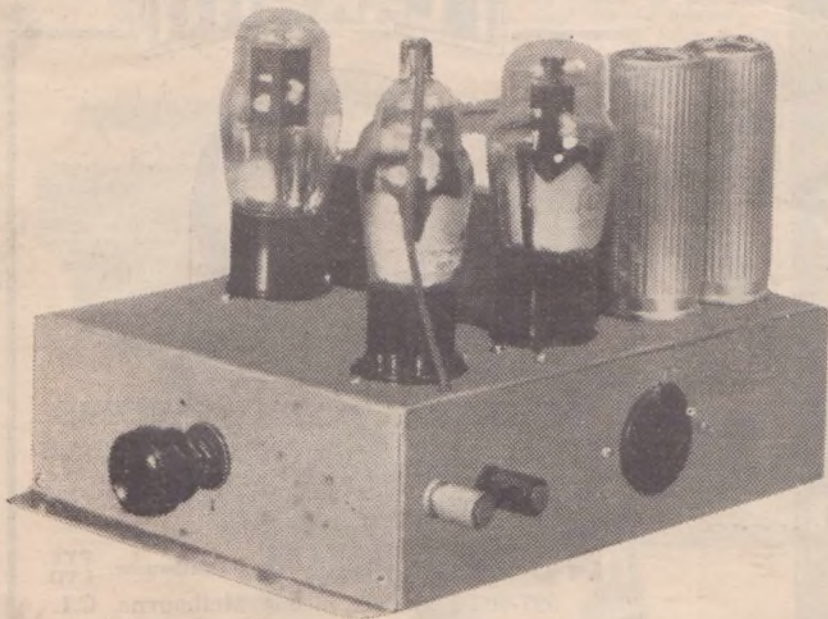

A corner view of the completed amplifier chassis showing the input terminals and the dynamic speaker output socket mounted on the right hand side. The volume control is assembled on the front side of the chassis.

the simple expedient of adjustment to this control the volume of the amplifier can be kept at any desired level.

The input signal is fed from the plate of the 6B7S tube through the resistance coupling network, which consists of R3, C4 and R4, to the grid of the 42 (V2), whence the output of which is reproduced in the dynamic speaker, DS.

De-coupling resistors have been used on the screen and plate leads of the 6B7S, which are by-passed to earth by the condensers, C3 and C7, respectively.

The field of the dynamic speaker has a resistance of 1500 ohms and is used as the filter choke in addition to obtaining its necessary field excitation.

The power transformer is a standard design with 335 volts each side of the centre tap, one 5 volt winding for the filament of the 80 rectifier and one 6.3 volt winding for the filaments of the remaining two valves.

A voltage divider of 15,000 ohms is connected across the "B" supply, and the various voltages for V1 and V2 are obtained from tapings on VD.

Chassis Assembly

The mounting of the parts on the chassis should not present much difficulty to the average set builder, but for the benefit of the radio enthusiast who has not had much previous experience we will give a brief outline of the essential points which must be taken into consideration.

The chassis is made from aluminium, its overall measurements being 9 inches by 7 inches by 2½ inches. 16 gauge aluminium is used.

Having bent and cut the aluminium to the required dimensions, the next

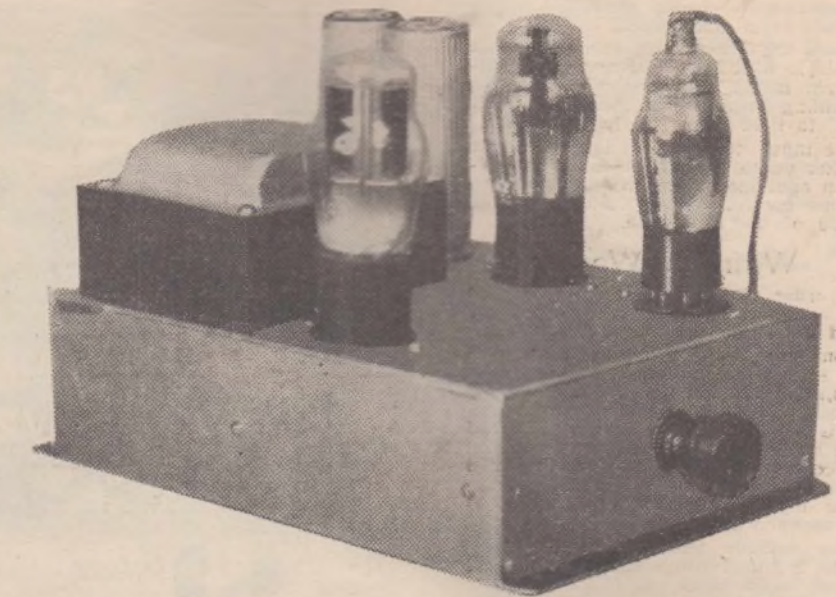

Another view of the amplifier chassis with the 80 rectifier tube in the foreground.

thing is the mounting of the parts on the chassis.

The original photographs accompanying this article should illustrate to the builder the mounting positions of the various parts on the chassis, and we will therefore only give a few hints in order to assist him in the assembling of them.

The mounting of the valve sockets

should be arranged in such a manner to allow all leads to be made as short as possible. This can be achieved by facing the heater terminals of the sockets to the side of the chassis. When fastening these sockets to the aluminium, place a small soldering lug beneath the mounting screws. This will permit a common earth wire to be carried

THE SCHEMATIC CIRCUIT DIAGRAM AND THE LIST OF COMPONENTS Required to Build the Compact Audio Amplifier

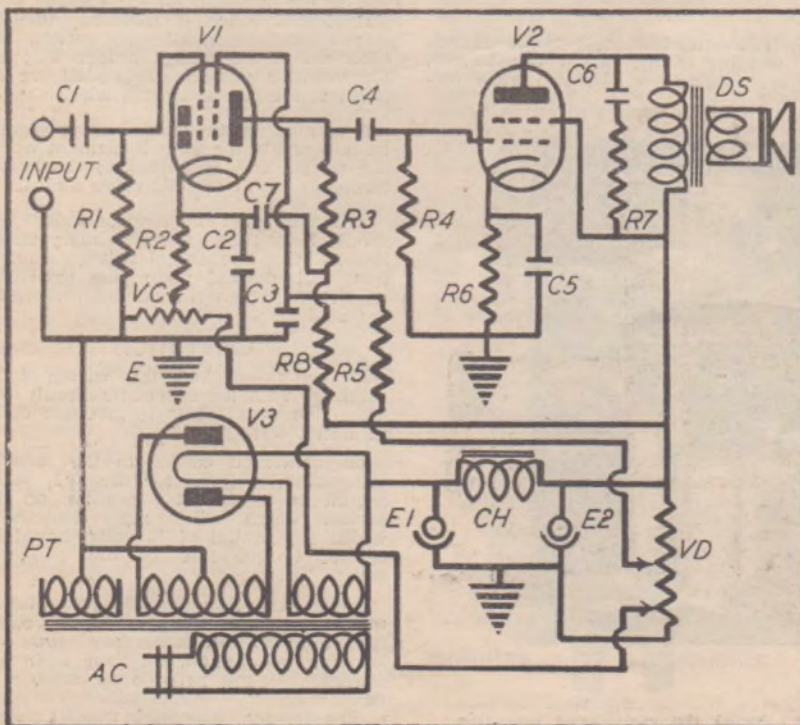

- C1, C4.—.02 mfd. fixed condensers.
- C2, C5.—25 mfd. 25 volt test electrolytic condensers.
- C3, C7.—.5 mfd. fixed tubular condensers.
- C6.—.01 mfd. fixed tubular condenser.

(All T.C.C.)

DS and CH.—DYNAMIC speaker to match type 42 valve with field resistance of 1500 ohms. (Amplion, Rola).

E1, E2.—8 mfd. 600 volt test electrolytic condensers (T.C.C.).

PT.—Power transformer. 385-0-385, one 5 volt winding and one 6.3 volt winding. (Stedi-Power).

R1, R4.—500,000 ohm resistors.

R2.—500 ohm W.W. 10 m.a. resistor.

R3, R5.—250,000 ohm resistors.

R6.—410 ohm W.W. 50 m.a. resistor.

R7.—10,000 ohm resistor.

R8.—50,000 ohm resistor.

VC.—5000 ohm potentiometer with insulating washers

VD.—15,000 voltage divider.

(All I.R.C.)

Valves.—Type 6B7S, 42 and 80 with sockets to match. (Mullard, Philips, Radiotron, Raytheon).

Sundries.—One grid clip, 6 yards of belden wire, 2 terminals with insulating washers, 1 UX valve socket, and 1 chassis measuring 9in. x 7in. by 2½in. nuts and screws, etc.

throughout the chassis when the wiring of the set is commenced.

Below the chassis, the only component which is mounted directly to the aluminium is the voltage divider VD, the remaining parts relying upon their "pig-tails" to hold them rigidly in position.

The input terminals and the dynamic speaker output socket are shown mounted on one side of the chassis, while the volume control, VC, is fastened in the centre of the front side.

Wiring in Words

In order to simplify the building of this amplifier we will give a word for word description of the wiring.

Commence the wiring by connecting one side of C1 to one of the input terminals mounted on the side of the chassis. The other side of the condenser, C1, is soldered to one end of R1, lead then being taken through the chassis to the control grid on top of the 6B7S valve. The remaining end of R1 and the other input terminal are connected to the common earth wire.

The cathode terminal on V1 valve socket is joined to one end of R2, C2 and C7, while the other end of R2 is soldered to the movable arm of the potentiometer, VC. The other side of C2 is taken to earth. One of the outer terminals of VC is soldered to the earth wire, while the remaining outer terminal on VC is taken to a tapping on the voltage divider VD, which will supply 15 volts.

The screen terminal on V1 valve socket is joined to one side of R5, the other side of the resistor being soldered to tapping on the voltage divider, which will supply 100 volts. This lead is by-passed to earth through the medium of the condenser, C3.

The plate terminal on V1 valve socket is connected to one side of R3 and C4. The other end of R3 is soldered to the remaining side of C7 and to one end of R8. The other end of R8 is taken direct to the maximum supply.

The remaining side of C4 is joined to R4 and to the grid terminal on V2 valve socket. The other end of the resistor, R4, is taken to earth.

One side of C5 and R6 are connected to

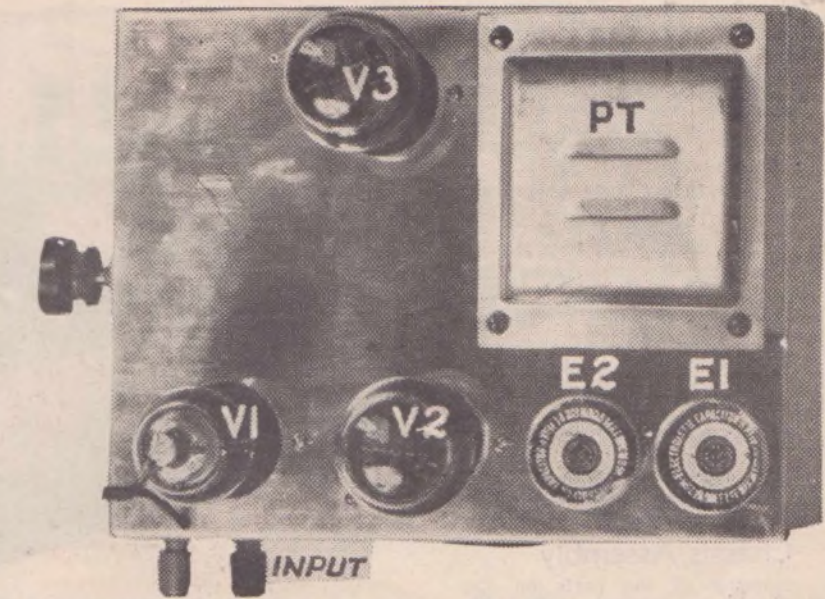

Looking down on top of the chassis, the builder will obtain an excellent idea of the layout of the parts. All components are keyed to correspond with the written description of the amplifier.

the cathode terminal of the V2 valve socket, and the other ends of these two components (C5 and R6) are soldered to the common earth wire.

The plate terminal on V1 valve socket is connected to the P terminal on the output socket, which is mounted on the side of the chassis. The screen terminal on the V2 socket is taken to the G terminal on the speaker output socket. The condenser, C6, and the resistor, R7, are connected between the plate and screen terminals of the V2 valve socket, as shown in the schematic circuit diagram.

The two outer terminals on the secondary winding of the power transformer, PT, are soldered to the two plate ter-

minals on the rectifier valve socket, V3. The centre tap of the secondary and the 6.3 volt windings are connected to earth. The 5 volt filament winding on PT is connected to the two filament terminals on the V3 valve socket. A lead is taken from one side (or the centre tap) of the 5 volt winding to the positive side of E1, and to one of the filament terminals on the speaker output socket.

Another lead is taken from the remaining filament terminal on the speaker output socket and is soldered to the positive side of the E2, to one of VD, and to the terminal on the speaker output socket, which is soldered to the screen terminal on V2 valve socket. The other end of the voltage divider, VD, and the negative side of E1 and E2 are all taken to the common earth wire.

A pair of tightly twisted wires should be soldered to the 6.3 volt filament winding on PT and connected to the heater terminals on V1 and V2 valve sockets.

A length of twin electric light flex should be soldered to the primary winding on PT. The actual voltage connection will depend upon the particular locality in which the amplifier is to be operated.

Operation

Having re-checked the wiring of the amplifier with the schematic circuit diagram, the next job is to give the outfit its initial test.

As mentioned earlier in the article, the screen voltage for the V1 valve should be tapped at a position on the divider which will supply 100 volts, whilst a potential of 15 volts should be applied to one side of the potentiometer, VC.

Under test this amplifier was found to give extraordinarily good reproduction, and we can safely say that, in building this design, we have definitely proved that the pentode is capable of performing in a manner which will compare with any standard triode output amplifier.

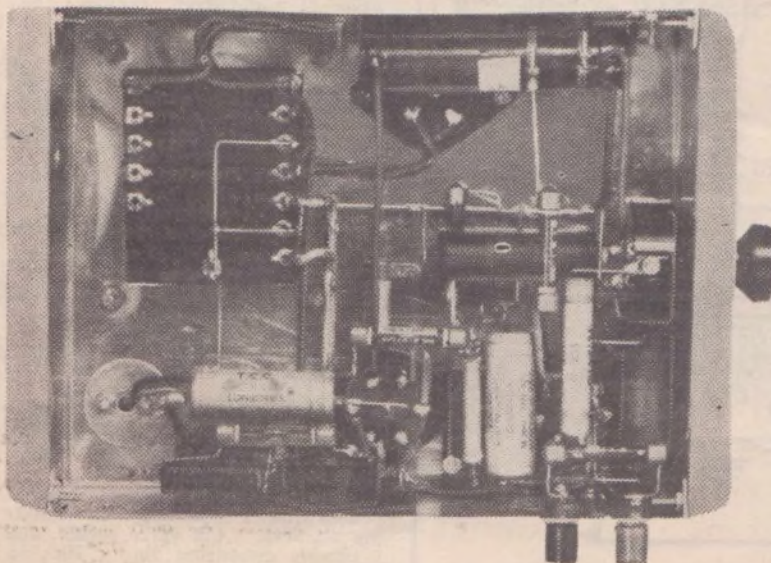

An underneath view of the amplifier chassis showing the wiring and mounting positions of the various components beneath the chassis.

THE EXCEL TONE SUPER "4/5"

The accompanying photograph of the receiver shows the arrangement of the controls, the uppermost one being the main tuning control whilst the one directly below it is the volume control.

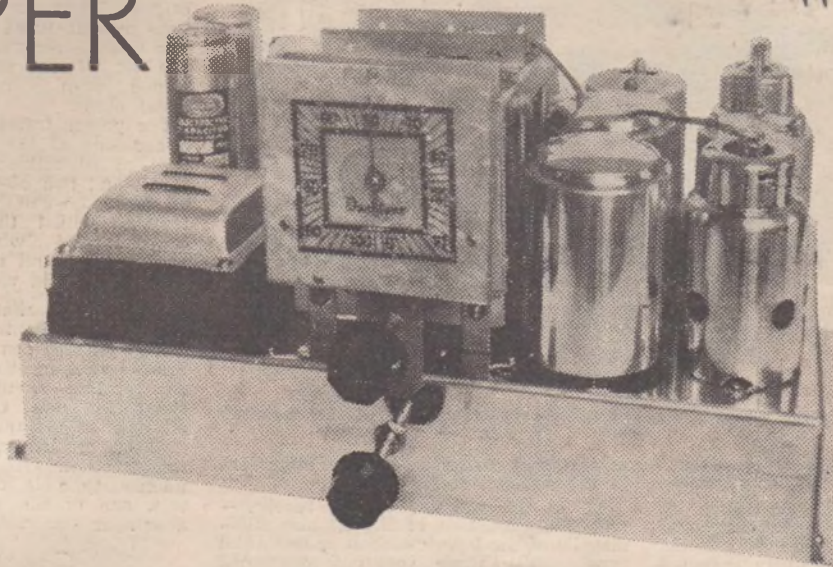

A simple and efficient Super-heterodyne receiver capable of excellent tonal quality, coupled with amazing distance-getting ability.

By H. R. SETFORD

DESPITE many assertions to the contrary it is possible to obtain excellent tonal quality from a super-heterodyne type of receiver providing due attention is paid to the tuning circuits and care taken that the audio frequency channel is capable of handling the highest and lowest musical frequencies passed to it by the radio frequency portion of the receiver.

The majority of super-heterodyne circuits published in the last twelve months have used a pentode output valve, as these valves are capable of high outputs with small input signals. It must be admitted that it is harder to obtain good tone from these pentode valves than from the many types of triodes now available. For this reason it was decided to use the ever-reliable 45 type triode valve as the output tube in this receiver.

The receiver is designed primarily for high quality local reception, but on many occasions it has provided reliable interstate reception of excellent strength.

THE radio-frequency portion of the receiver is fairly standard, and consists of a mixer stage, followed by a stage of intermediate frequency tuned to a frequency of 455 K.C. A type 2A7 pentagrid converter is used as the mixer valve, the control grid circuit of which is tuned by the condenser coil combination, G1 and L1-L2, to the frequency of the incoming signal. Section G2 of the gang condenser of the coils, L3-L4, tune the oscillator portion of the 2A7 to a frequency 455 K.C. greater than the incoming signal. The resultant beat between these two signals is fed through the intermediate-frequency transformer, IFT1, to the grid of the intermediate frequency amplifier valve, V2.

This valve, which is a type 58 variable mu pentode, in turn amplifies the signal, which is then fed through IFT2 to the rectification diode of the 2A6 valve, V3. Part of this signal is fed by condenser, C9, to the remaining diode plate of this valve, which makes available a

rectified voltage suitable for automatic volume control purposes. This voltage is developed across the voltage dividing resistors, R5 and R6. The full available voltage is fed to the grid of the 2A7 through the decoupling resistor R1 and the bypass condenser, C1.

Resistors R5 and R6 are of the same resistance; therefore half of this voltage is available at the junction of these two resistances. This voltage is fed to the grid of the intermediate-frequency amplifier valve, V2, and by-passed to earth by the condenser, C7.

Let us see how this automatic volume control system operates. The signal appears at the plate of the mixer valve at the intermediate frequency, and is amplified by the intermediate frequency amplifier, V2. Quite a large voltage is produced across the primary winding of IFT2; a corresponding voltage is induced into the secondary of this transformer, and is rectified by the detector diode and fed as an audio frequency voltage to the grid of triode section of the 2A6, part of the signal appearing at the plate of the 58 is fed through the condenser C9 to the A.V.C. diode; and a voltage is produced across R5 and R6.

By reason of the fact that both the grid returns of the 2A7 and 58 valves are connected to these resistors, this voltage will be applied to the grids of the two valves. As both these valves are of the variable mu type, this voltage causes the gain of the valve to become much less, thereby lowering the sensitivity of the receiver.

Features of This Receiver

- Perfect tonal quality.
- Delayed automatic volume Control.
- Ease of construction.
- Simplicity of operation.
- Minimum of components.
- Excellent range.

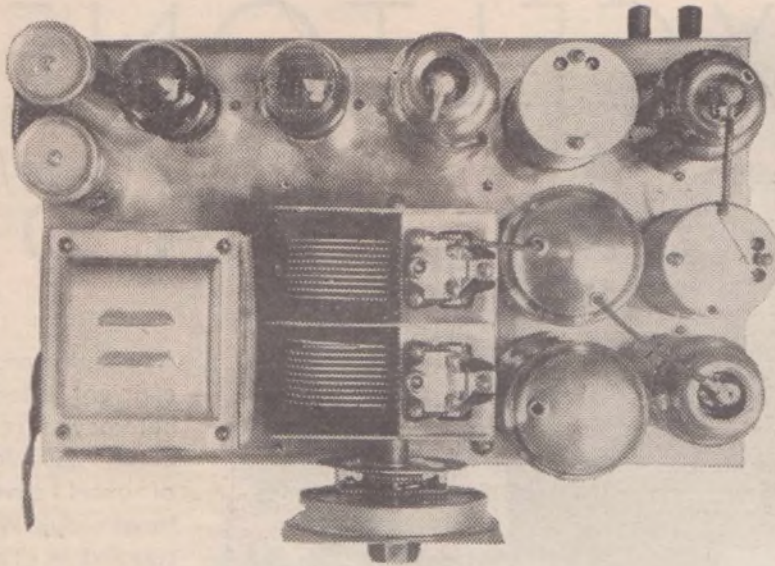

A top view of the receiver showing the placement of parts on top of the chassis.

Review of Components

Particular care should be taken in the selection of the gang condenser and coils to be used in this receiver. These components must be carefully matched if reliable results are to be obtained. Great care must be taken when handling and mounting the gang condenser to see that the plates are not warped or their position disturbed in any way

as this will result in lack of alignment in the finished receiver.

All of the resistors in the receiver—with the exception of R3, R4 and R10—may be of the 1-watt carbon or metalised type. The three resistors mentioned must be of the wire-wound variety capable of carrying the current quoted in the list of parts.

The condenser used in the original receiver were all of the tubular or pig-

tail type. The volume control, VC, should be selected with care. It should be of reliable make and should give a smooth variation of resistance from minimum to maximum.

The electrolytic condensers, E1 and E2 are of 8 mfd. each and are of the 500-volt working type. The intermediate-frequency transformers should also be selected carefully. Those used in the original receiver are of the high-gain type manufactured by Airmaster Radio. The audio-frequency transformer, is a product of the same firm, and is designed with a primary impedance of 14,000 ohms.

The power transformer gives 385 volts either side of the centre-tap at a current of 80 milliamperes, and has one 5-volt and two 2.5-volt secondaries. One of these 2.5-volt windings is centre-tapped, whilst the other is not. The centre-tapped winding supplies the power valve and the other winding the remaining three valves in the cascade.

The valve sockets should also be selected carefully to see that they give a firm, smooth contact at the valve pins. The speaker for this or any other quality receiver should be the best that can be afforded. Cheap parts may work all right in the rest of the receiver, but a cheap speaker can never give quality reproduction. A speaker of the high fidelity type is desirable, but, failing this, one of the well-known makes in a smaller size will give good results.

Construction

The receiver is constructed on an aluminium chassis measuring 14in. by 8½in. by 2½in. in depth. The gang condenser is mounted centrally on top

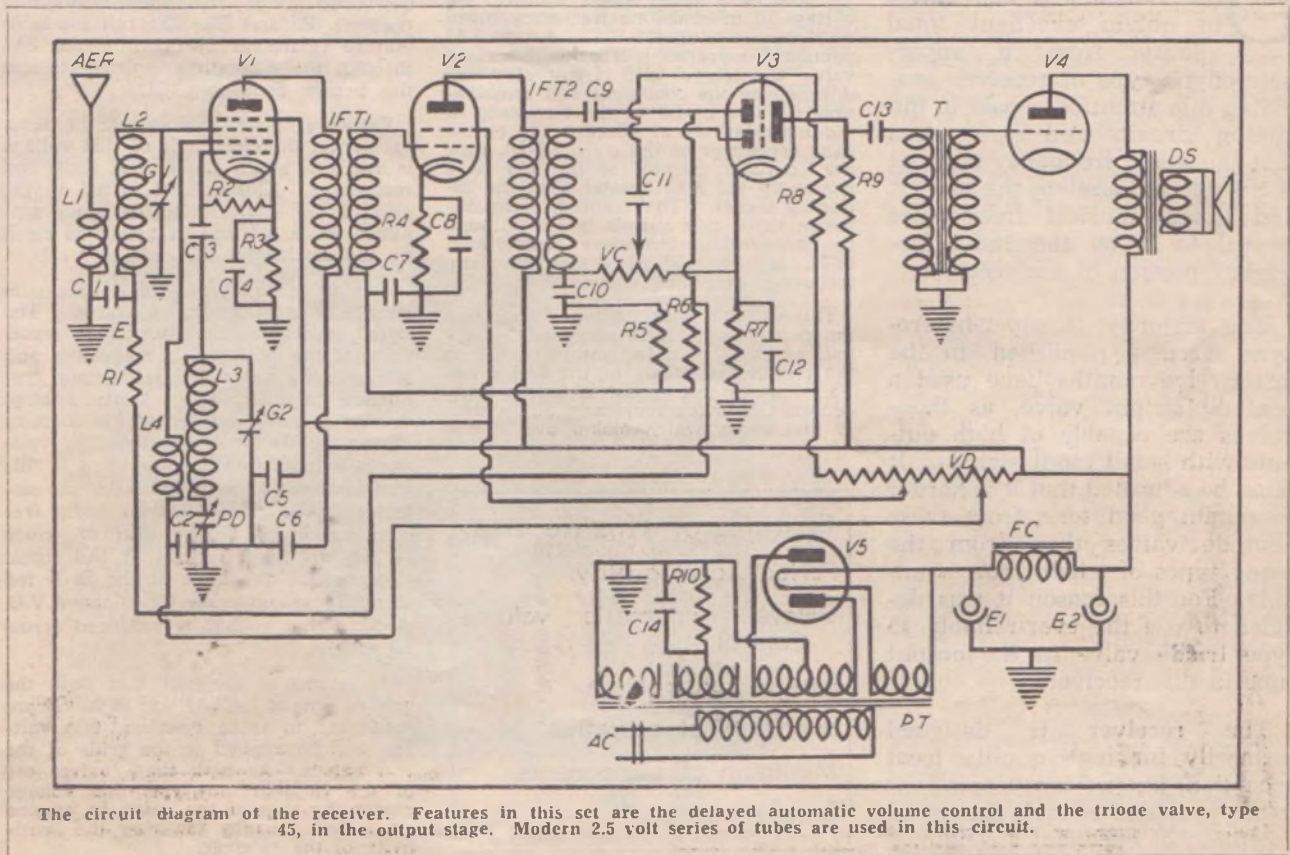

The circuit diagram of the receiver. Features in this set are the delayed automatic volume control and the triode valve, type 45, in the output stage. Modern 2.5 volt series of tubes are used in this circuit.

of the chassis, and the aerial and oscillator coils bolted to the chassis to the right of it, the oscillator coil being the one nearer the front edge of the chassis. The mixer valve socket is mounted in the right front corner, and the mixer valve socket is situated in the rear right-hand corner of the chassis.

Between these two valves is the first intermediate frequency transformer. Situated from left to right along the back of the assembly are the two electrolytics, the rectifier valve, the 45 power valve, the 2A6 diode triode and the second intermediate frequency transformer.

The only remaining components to be mounted are the padder condenser and the power transformer. The former is mounted on the front of the chassis between the gang condenser and the oscillator coil, whilst the latter is situated in the front left-hand corner of the chassis.

The position of the audio frequency transformer may be seen from the underneath photograph of the receiver, as also the positions of the voltage divider and the pigtail condensers and resistors.

The aerial terminal at the rear right of the chassis must be carefully insulated from the chassis by fibre washers or some other insulating material. The earth terminal may be bolted direct to the aluminium chassis.

Having mounted the various components, the wiring may be commenced by wiring the filament or heater circuits of all the valves. All of this heater wiring should be carried out in twisted pairs to prevent the possibility of A.C. hum being introduced into the circuit.

Solder two wires to the heater terminals of the 2A7 socket, and, after having twisted them together, solder the vacant ends to the heater contacts of the 58 socket. A similar twisted pair connects these heater contacts to the corresponding contacts of the 2A6 socket and thence to the 2.5-volt winding of the power transformer which has no centre-tap. The centre-tapped 2.5-volt winding is wired with another twisted pair to the filament terminals of the 45 valve socket. The filament contacts of the 80 socket connect to the 5-volt wind-

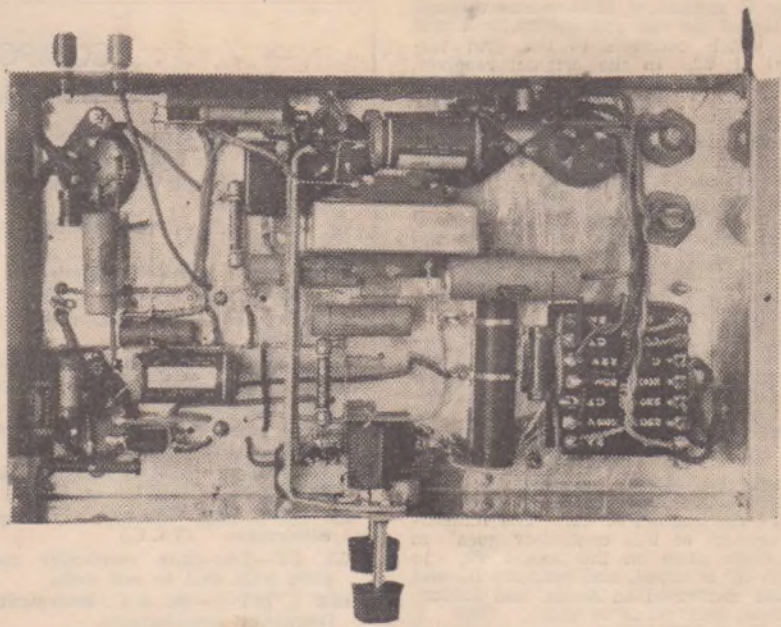

An underneath photograph of the receiver, showing the simplicity of wiring, and the positions of the various components.

ing on the power transformer and these leads, as well as two which connect the plate contacts of this socket to the outside high voltage secondary terminals, must be twisted in a similar manner. The centre-tap of this high voltage secondary joins to earth, as does one side of the 2.5-volt winding supplying the mixer, IF, and second detector valves.

Solder a lead to the centre contact of E2 and connect it to one of the filament terminals of the 80 socket and to one of the large contacts of the speaker socket. Solder together the remaining large contact on this socket and one of the smaller ones and connect them to the centre terminal of E1 and one end of the voltage divider, VD. The remaining end of VD joins to earth. Connect the aerial contact of L1 to the aerial terminal and the earth contact of the

same coil to chassis. It is advisable to solder pieces of tinned wire to convenient solder lugs situated around the chassis and join to this tinned wire all of those connections which connect to earth.

The G contact of L2 joins to the fixed plates of the section G1 of the gang condenser, and to the grid clip, which connects to the control grid of the 2A7 valve. Both these leads may be seen in the photographs coming out of the aerial coil on top of the chassis.

The E contact of L2 connects to one side of C1 and to one contact of R1. The remaining contact of C1 connects to earth, whilst that of R1 joins to one of the diode plates on the 2A6 socket.

Connect together the screen-grid contacts of the valve sockets, V1 and V2, and connect them to the 100-volt tap on the voltage divider. The screen by-pass condenser, C5, connects from the screen terminal of V1 to earth. Solder one contact each of R3 and C4 to cathode terminal of V1, and join their remaining contacts to earth.

Solder one side of the .001 mfd. grid condenser C3 to the oscillator grid contact of socket V1 and connect R2 between this contact and the cathode terminal of the same socket.

Connect the G contact of L3 to the remaining side of C3 and to the remaining fixed plate contact of the gang condenser. The E contact of L3 joins to the fixed plates of the padder condenser, PD, the moving plates of which join to earth. The P contact of L4 connects to the oscillator plug lug of V, whilst the remaining contact of L4 connects to the 200-volt tap on the voltage divider, VD.

A .1 mfd. condenser, C2, connects from this point to earth. The only remaining contact on socket V1 is the plate terminal which connects to the plate contact of IFT1. The B positive contacts of IFT1 and IFT2 are connected together, and joined to the two contacts of the speaker socket which likewise are connected together.

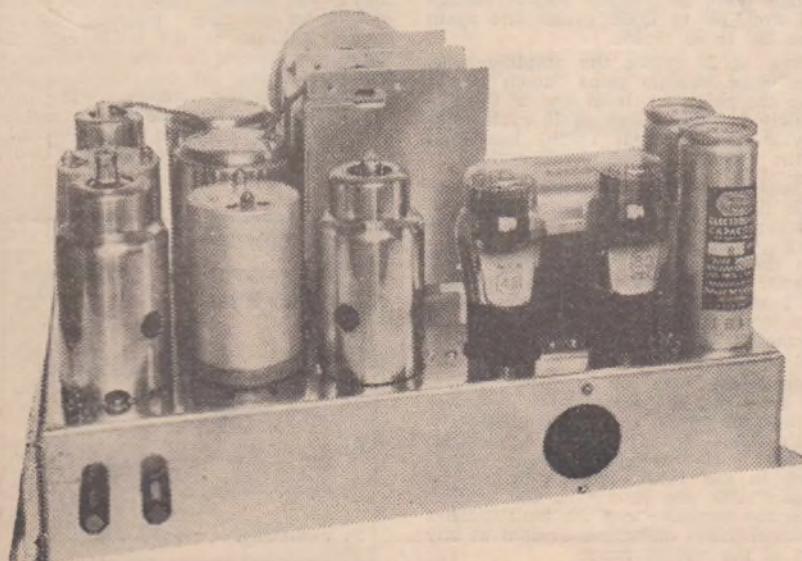

Another photograph of the receiver, showing the location of the aerial and earth terminals, and the speaker output socket.

The G contact of IFT1 comes through the top of the can and solders to a grid clip, which connects to the grid terminal of V2. In the original receiver, condenser C9 and resistors R5 and R6 were housed inside the can of IFT2. Should the constructor have difficulty in arranging them in this manner, they may be connected beneath the chassis, providing care is taken to keep all leads to them as short as possible. The E contact on IFT1 connects to one side of the .05 mfd. condenser, C7, and to the junction of R5 and R6. This lead should be carried out with shielded wire, the outside metal braid of which is carefully earthed.

The cathode and suppressor grid terminals of socket V2 are connected together, and to them is soldered one contact each of R4 and C8. The remaining contacts of these components are joined together, and go to earth, as does the remaining contact of C7.

The plate contact of V2 connects to the P terminal of IFT2, to which is connected one contact of C9. The remaining contact of this condenser goes to the diode plate on the socket V3, to which R1 is wired, and resistors R5 and R6 are connected in series, and soldered from this point to earth. The E contact of IFT2 must have a piece of braided wire attached to it long enough to connect to one of the outside contacts of the volume control potentiometer, VC. A piece of braided wire also connects the grid pin on the 2A6 valve to one side of C11. The other side of C11 joins to the arm of the potentiometer. The remaining contact of this component connects with another piece of shielded wire to the cathode contact of V3. The outside shielding of these three wires should be carefully soldered together, and connected to earth.

The 1-megohm grid resistor, R8, solders between the side of C11, which connects to the grid of the 2A6 and earth. The remaining contact of IFT2 connects to the unconnected diode plate of the valve socket V3. Solder one terminal each of R7 and C12 to the cathode terminal of V3, and connect their remaining contacts to earth. The only contact on V3 which remains to be connected is the plate terminal, and this connects to one side of C13. Resistor R9 solders between the contacts of the speaker socket, which are connected together, and to the plate contact of V3.

The unconnected side of C13 joins to the P contact of AFT. The E and B positive terminals of this component join together, and connect to earth. The G contact of AFT is wired to the grid contact of V4. The plate contact of V4 connects to the remaining lug on the speaker socket. One contact each of R10 and C14 connect to the centre-tap of the 2.5-volt winding, supplying V4, whilst the remaining contacts of these components go to earth.

Condenser C6 may now be soldered between the two contacts of the speaker socket, which are connected together, and then to earth. Condenser C10 also remains to be connected. This condenser is soldered to the outside lug of VC which is connected to IFT2, whilst its remaining contact joins to earth.

With the connection of the power leads to their respective contacts on PT, the wiring is completed, and the valves may be placed in their correct sockets, the speaker plug inserted, and the aerial and earth wires connected.

Details of the adjustments necessary for the alignment of this type of re-

ceiver have been given so often that the procedure will not be repeated here.

As mentioned previously, this receiver was designed primarily for quality local reception, and as such it is one of the best receivers with which we have come in contact. Connected to one of the high fidelity type speakers, the tonal quality is little short of amazing, the

high frequency response being particularly pleasing.

In the suburban area, connected to a reliable aerial and earth system, no difficulty was experienced in tuning in the majority of Australian stations, the automatic volume control system proving its worth in correcting the tendency of many of the stations to slight fading.

COMPONENTS LIST

A.F.T.—4 to 1 ratio audio-frequency transformer.

Chassis of aluminium measuring 14 inches by 8½ inches by 2½ inches.

Coils.—Aerial and 465 oscillator coil to suit 2A7.

C1, C2, C4, C8.—.1 mfd. tubular condensers.

C7.—.05 mfd. tubular condenser.

C5, C6.—.5 mfd. tubular condensers.

C3, C9, C10.—.0001 mfd. mica condensers.

C11, C13.—.02 m.f.d. mica condensers.

C12.—25 mfd. low voltage electrolytic condenser.

C14.—10 mfd. 75-volt electrolytic condenser. (All T.C.C.)

DS.—Dynamic speaker, 1500-ohm field to suit 45. (Amplion or Rola.)

E1, E2.—8 mfd. 500-volt electrolytic condensers. (T.C.C.)

G1, G2.—Two-gang condenser complete with dial to suit coils.

IFT 1, IFT 2.—465 K.C. Intermediate frequency transformers.

PD.—465 padder condenser.

PT.—Power transformer 385-0-385 1—5-volt 2 amp. 1—2.5-volt 5 amp. 1—2.5-volt 2 amp.

R1, R8.—1 megohm resistor.

R2.—50,000-ohm resistor.

R3, R4.—300-ohm 20 milliampere resistors.

R5, R6, R9.—500,000-ohm resistors.

R7.—600-ohm resistor.

R10.—1500-ohm resistor to carry 50 milliamperes. (All I.R.C.)

Sockets.—1 small 7-pin, 2 6-pin, 3 4-pin.

Valves.—One each 2A7, 58, 2A6, 45 and 80.

VC.—500,000-ohm potentiometer (I.R.C.).

VD.—25,000-ohm voltage divider (I.R.C.).

Sundries.—Wiring flex, 1 yard shielded wire, 3 valve shields, nuts and bolts, aerial and earth terminals, 3 grid clips and 2 knobs.

THE LISTENER IN HIGH FIDELITY AMPLIFIER

(Continued from Page 52)

The final set of frequency response figures showed that the amplifier is aurally flat from 50 to 13,000 cycles, although there is a slight output voltage fall from 700 to 13,000 cycles and again from 200 to 50 cycles.

Even at 20 cycles the amplifier was only three audible steps "down" (6db) from the reference level and at the extremely low frequency of 10 cycles was only 9 audible steps (18db) less than at the reference level of 400 cycles.

These measurements were conducted with the aid of precision equipment, and can be relied upon within a very small percentage of error. They show that the amplifier is remarkably good, so good in fact that it could not be bettered except in a straight-out laboratory type amplifier in which absolute evenness of response was more important than cost.

Aural tests with the completed amplifier bore out the findings of the measuring equipment. The amplifier is really High Fidelity and is a pleasure to hear. Its maximum power output taxes to the limit even a large loud speaker like the Rola G12, but neither from the amplifier nor the loud speaker is the slightest distortion evident at any part of the output range.

Before this article was written the amplifier was demonstrated to a criti-

cal audience of radio traders and radio technicians, whose unanimous opinion was that the amplifier was the best they'd yet heard. This, the considered opinion of critically minded experts, should indicate to the home constructor that provided he adheres rigidly to the instructions set out, he need have no fear as to the outcome of his effort to build a really modern amplifier which will respond to even the High Fidelity transmissions of modern broadcasters.

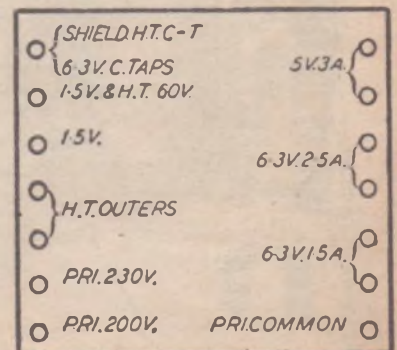

The wiring connections to the Alrmaster H.F.2 power transformer.

EVERY RADIO MAN NEEDS GHIRARDI'S MODERN RADIO SERVICING

NEW EDITION—COMPLETELY
REVISED — ENLARGED

ALSO—

RADIO FIELD SERVICE DATA

By A. A. Ghirardi and B. M. Freed

Now, more than ever before, complexity of circuits and tubes has made necessary a greater knowledge of the fundamentals of electrical and radio circuit design — servicing — trouble finding and remedies. Ghirardi's "Modern Radio Servicing" is expressly written to give the radio man that knowledge. The author is recognised as one of the greatest living authorities on modern radio.

The enthusiastic reception given the 1st edition of this book ("Radio Servicing Course") by both students and radio service men, prompted Mr. Ghirardi to revise it completely in order to bring it up-to-date. To do this he had to write an entirely new book.

This new edition contains 1300 pages and 706 illustrations. Throughout the book there are very many useful cross-references. An unusually complete index, cross-reference, is included so that information on any of the many subjects may be quickly found. The book is divided up into (1) theory and construction of modern radio test equipment; (2) the practical servicing of radio receivers; (3) specialised servicing problems.

A glance at the table of contents below will show how exhaustively the whole field of Radio Servicing is covered.

RADIO FIELD SERVICE DATA contains a wealth of service data particularly valuable to the service man when he is actually at work. Bound in a flexible cover so that it may be easily carried in the service man's tool bag. It contains a complete tabulation of the intermediate frequencies of all American superheterodyne receivers, a comprehensive trouble-shooting chart listing the most common symptoms, troubles and their remedies for over 750 popular receivers, the answers to the numerical review problems which are included at the ends of various chapters of Modern Radio Servicing, and a wealth of data and tables which are extremely useful to every service man in the field.

Contents—Modern Radio Servicing

Milliammeters, ammeters, and voltmeters—Methods and instruments for measuring resistance—How to construct ohmmeters—Typical commercial ohmmeters—Condenser testers and capacity meters—Output meters and V.T. voltmeters—The tube checker—How to construct a modern tube checker—Typical commercial tube checkers—The voltage-current set analyser—Point-to-point testing—How to construct a complete set analyser—Typical commercial set analysers—The service test oscillator—How to construct and calibrate a test oscillator—Typical commercial test oscillators—Preliminary tests for trouble—Peculiarities of A.V.C. and Q.A.V.C. circuits—Receiver analysis by voltage-current tests—Receiver analysis by resistance tests—Testing individual radio components—Obscure troubles not revealed by analysers—Aligning and Neutralising T.R.F. receivers—Aligning and Neutralising superheterodyne receivers—Repairing individual radio components—Installing and servicing auto-radio receivers—Servicing all-wave receivers—Installing and servicing marine radio receivers—Reducing electrical interference—High-fidelity receiver problems—How to sell your service—Vacuum tube charts.

SPECIAL TERMS TO "LISTENER IN" READERS

CONTENTS — RADIO FIELD SERVICE DATA

Intermediate peak frequencies of receivers—Receiver trouble symptoms and remedies—Remedies for stubborn automobile ignition interference—Electrical wiring diagrams of automobiles—Battery polarity, breaker-point and spark-plug gaps and auto-radio antenna data for American cars—Trouble-shooting chart for common receiver troubles—Radio tube characteristics chart—Tube base and socket terminal arrangement charts—Rectifier tube characteristics—Operating conditions for combination tubes in resistance-coupled amplifiers—Grid-bias resistor chart—Resistance and power rating graphs for resistors—R.M.A. standard color codes—Table of condenser reactances at various frequencies—Litz wire table—Copper wire table (Bare and Magnet)—Resistance Data for metals and alloys—Transformer turns per volt—Metric Prefixes used in radio work—Use of exponents in calculations—Summary of common radio formulas—Wave-length, frequency and LXC conversion table—Tools for radio service work—Drill and tap sizes—Fractions and their decimal equivalents—Answers to numerical problems in modern radio servicing.

ORDER FORM

ANGUS AND ROBERTSON LTD.,
Publishers to the University,
89 Castlereagh Street, Sydney.

Please send me (1) Ghirardi's Modern Radio Servicing. I enclose the first instalment of 10/- and agree to make two further monthly payments of 10/. (Postage, 1/3 extra.) The price for cash within 30 days is 27/6, plus postage. (2) Ghirardi and Freed's Radio Field Service Data, for which I enclose 9/6. (Postage, 6d extra.)

NAME

ADDRESS

OCCUPATION DATE

BUSINESS ADDRESS

L.I.H. 25/5/36

ALL-METAL OR GLASS



Radiotron aims to give its Distributors, Dealers, Salesmen and Customers only the best, whether the valve be of metal or glass.

Nowhere will you find more experience, skill or effort in the manufacture of radio valves, glass or metal, than in the Radiotron Laboratories and Factories.



RADIOTRONS

AMALGAMATED WIRELESS (AUSTRALASIA) LIMITED

47 York Street, Sydney
167-169 Queen Street, Melbourne

AUSTRALIAN GENERAL ELECTRIC LIMITED

Sydney Melbourne
Brisbane Adelaide Hobart

V1-6